

# J-SERIES CRAWLER DOZERS

450J / 550J / 650J



JOHN DEERE





# Push productivity to the next level.

Often imitated but never duplicated, John Deere dozers continue to set the standard for operator control and productivity. Backed by 30-plus years of hydrostatic experience, their unique state-of-the-art Total Machine Control (TMC) enables an operator to customize machine operation and response to personal preferences. Coupled with an uncommonly smooth full-featured hydrostatic transmission, the J-Series delivers unsurpassed productivity, uptime, and daily operating costs. That's for starters. Read on and learn more about all of the J-Series Dozers' many productivity- and uptime-boosting advantages.

|                         |                      |                      |                      |
|-------------------------|----------------------|----------------------|----------------------|
| <b>Specifications</b>   | <b>450J LT</b>       | <b>450J LGP</b>      |                      |
| <b>Rated Power</b>      | 57 kW (77 hp)        | 57 kW (77 hp)        |                      |
| <b>Operating Weight</b> | 7386 kg (16,283 lb.) | 7949 kg (17,525 lb.) |                      |
|                         | <b>550J LT</b>       | <b>550J LGP</b>      |                      |
| <b>Rated Power</b>      | 63 kW (85 hp)        | 63 kW (85 hp)        |                      |
| <b>Operating Weight</b> | 7718 kg (17,016 lb.) | 8279 kg (18,252 lb.) |                      |
|                         | <b>650J LT</b>       | <b>650J LGP</b>      | <b>650J XLT</b>      |
| <b>Rated Power</b>      | 74 kW (99 hp)        | 74 kW (99 hp)        | 74 kW (99 hp)        |
| <b>Operating Weight</b> | 8419 kg (18,560 lb.) | 8977 kg (19,750 lb.) | 8455 kg (18,600 lb.) |





Decelerator lets you choose between slowing travel speed and engine rpm, or travel speed only. For unparalleled low-effort toe-tip control.

Operator-favorite speed-in-grip steering and transmission control lever and rotary throttle are standard equipment.

Extended service intervals, larger fuel tanks, remote test ports, and diagnostic messaging help maximize uptime and productivity.

EPA Tier 3/EU Stage IIIA and Tier 2/Stage II John Deere diesel engines deliver power without compromise in all conditions.

Deere's unique TMC lets an operator customize the crawler's operating characteristics and response, and even records machine usage.



# Uncommon control, uncompromising results.

Others may offer hydrostatic drivetrains in their dozers. But no other dozer even comes close to delivering the proven performance and exceptionally smooth control you get with the 450J, 550J, or 650J. Power turns, counter-rotation, infinitely variable travel speeds — the J-Series' enhanced controls put you in complete command of a whole arsenal of highly productive hydrostatic advantages. No wonder John Deere finish dozers have become owner and operator favorites. And why they continue to deliver industry-leading resale value.



1. Counter-rotation is a productivity-boosting feature that enables the operator to overcome heavy corner loads and to quickly reposition the blade on the go. Provides space-saving spot turns, too.
2. With optional Integrated Grade Control (IGC), your 650J Dozer arrives from the factory “plug and play” ready. Its open-architecture design lets you employ the electronic grade-control system that’s right for you.
3. These dozers steer the same and maintain their preset speed whether they’re on level ground or a 2-to-1 slope. For total control regardless of the terrain.





Reliable controls command the full-featured hydrostatic drivetrain and six-way blade, ensuring predictable response at all times, in all conditions.

Power management takes the guesswork out of efficient operation. Simply set maximum desired ground speed and the system maintains peak engine and power efficiency without stalling or shifting.

Travel speeds that vary from standstill to 8 km/h (5 mph) let an operator choose the right speed for the job. Travel-speed range can also be modified for specific applications or terrain conditions, and even limited to maximize undercarriage life.

Blade ratio and center of gravity are optimized, giving these dozers the balance needed for superior grade work.

TMC allows maximum flexibility and control, letting you customize machine operation to personal preferences.

Proportional control lets an operator speed up or slow power to each track, for smooth, full-power turns.

Fully modulated drivetrain ensures smooth starts and direction changes — virtually eliminating jerky and abrupt movements.







# Get more done within our comfort zone.

Want your operators to be more productive? Put them in the seat of this spacious air-conditioned cab. From their ergonomically designed fully customizable controls to best-in-class visibility, J-Series Dozers are loaded with everything you need to keep your operators calm, cool, productive — and on the payroll.





Generous hydraulic flow and precise metering deliver a natural “feel” for the T-bar control that will enhance any operator’s grading skills. Blade response is powerful and quick.

Retractable seat belt, slip-resistant floor mat, convenient grab bars, neutral-start lever, and automatic park brake help keep the operator out of harm’s way.

Deluxe-suspension armchair adjusts seven ways for daylong comfort and support. Adjustable armrests and footrests are standard.

Single lever provides low-effort control of steering, forward/reverse travel, and ground speed. It’s also detented so it doesn’t require an operator’s constant touch or attention, and employs a thumb-actuated travel-speed switch.

Convenient 12-volt port provides power for cell phones and other accessories.

Automotive-type directional vents deliver warm or cool air with quiet efficiency. Air conditioning is standard in all cabs. For non-cab crawlers, an optional under-seat heater warms the operator.

1. Cab-forward design positions the operator for a more stable ride and a commanding view behind, below, and beyond the blade. Monitor keeps a vigilant watch on vital functions and issues visual or audible warnings.
2. Exclusive TMC lets you customize decelerator mode and response, forward/reverse ground-speed ranges, steering modulation, F-N-R shift rate, and forward/reverse speed ratios, for unsurpassed control.
3. Choose the decelerator function that’s right for the job. Slow both ground speed and engine rpm, or ground speed only to help maintain traction without affecting engine power and hydraulic response. Fully depressing the pedal applies the brakes.
4. High-intensity halogen driving lights are standard. Or opt for the factory-installed 360-deg. light package that delivers superior illumination.





# Nothing runs like a Deere, because nothing is built like one.

Designed and built with the latest tools and techniques by a quality-conscious workforce at a world-class John Deere manufacturing facility, Our dozers deliver unsurpassed reliability and uptime. But don't just take our word for it. Perhaps the best way to know what you can expect out of one is to see what goes into it. When you learn how they're built, you'll run a Deere.

Engine, hydrostatic pumps, and hydraulic pump are bolted to a subframe, forming an easy-to-remove powertrain package. It's attached to the mainframe on rubber mounts to isolate vibration and reduce noise.

Heavy-duty high-pressure hoses connect the pumps and motors that form the drivetrain. O-ring face-seal couplings virtually eliminate leaks.

Sealed transmission electrical connectors with gold-plated pins prevent moisture and contaminants from entering terminals for increased reliability.

Wet-sleeve cylinder liners provide uniform engine cooling and longer durability than cast-in-block designs.

Standard features such as bypass-start protection, automatic park brake, convenient handholds, and slip-resistant steps help keep the operator out of harm's way.

Undercarriage is sealed and lubricated and built to last. Available Maximum-Life undercarriage system utilizes SC-2™ bushing technology — plus larger track rollers, carrier rollers, idlers, and seals to deliver up to twice the undercarriage life, even in extremely abrasive conditions.

1. One-piece robot-welded mainframe resists torsional stress, absorbs shock loads, and delivers maximum strength while providing easy service access to major drivetrain components.
2. Large fuel tanks and 500-hour engine oil service intervals let you run longer between fill-ups and maintenance.
3. Heavy-duty triple-reduction final drives are attached to the mainframe, isolating them from track-imposed shock loads. Seal guards are built in, not extra-cost options.
4. Closed-cell blade design and robot-welded, fabricated, box-section C-frame is strong and durable. Heavy-duty ball-and-socket joint resists material buildup for long-term grading precision.





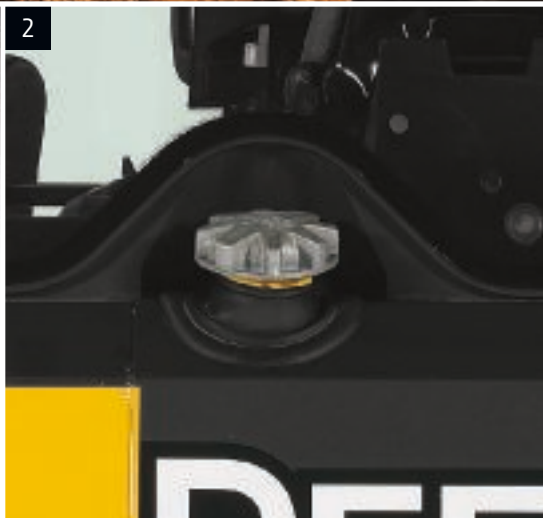





1. Unlike other crawlers that require a laptop computer, an advanced diagnostic monitor displays easy-to-understand messages.
2. Vertical filters allow quick, no-spill changes. Engine, hydraulics, and transmission utilize a common oil, further simplifying service.

3. Serpentine belt never needs adjusting. 500-hour service intervals let you go longer between engine oil changes.
4. Remote drive system test ports help speed troubleshooting for increased uptime and productivity.

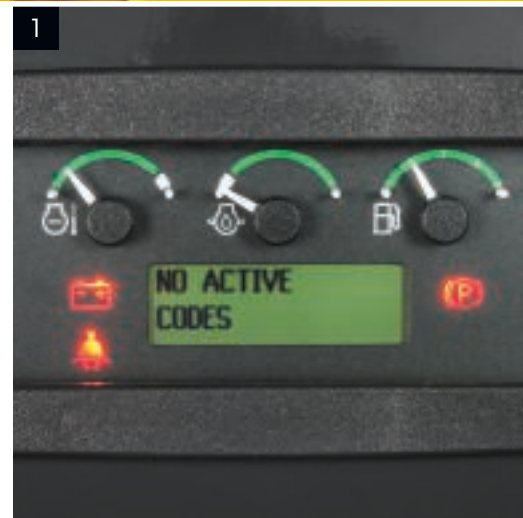





# Maintenance made easy.

If there's a way to reduce your daily operating costs and simplify maintenance, we've incorporated it into the J-Series Dozers. Service intervals have been extended, and same-side service points help make quick work of the daily routine. Lockable doors swing open wide, providing quick and ample access to dipsticks, vertical spin-on filters, sight gauges, and maintenance-free batteries. These and other timesaving features such as an easy-to-clean undercarriage, quick-to-replace hydraulic hoses, and designed-in diagnostics minimize downtime and expense.

Hydraulic and hydrostatic reservoirs are completely separated, eliminating any possibility of cross-contamination.

With JDLink™ you'll know exactly where your dozer is and how it's performing. This optional wireless communication system delivers location, utilization, performance, and maintenance data to your computer. Helps increase productivity and uptime, and lower operating costs.

Lube bank puts difficult-to-grease C-frame pivots within easy reach. Periodic maintenance and lube chart ensures that nothing gets overlooked.

Hinged side shields open wide and provide ground-level access to batteries; master electrical switch; cold-weather-start aid; and vertical transmission, hydraulic, and fuel filters.

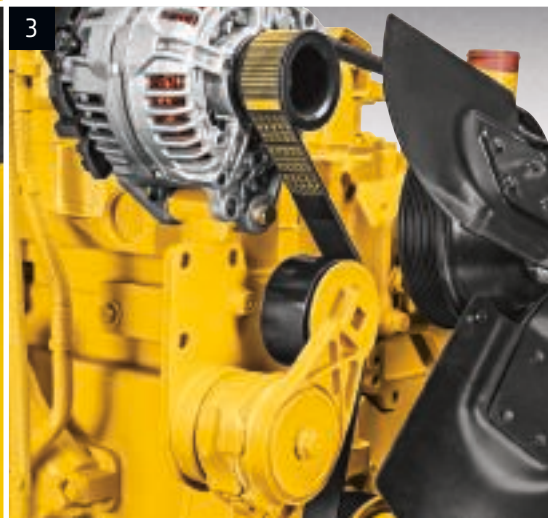
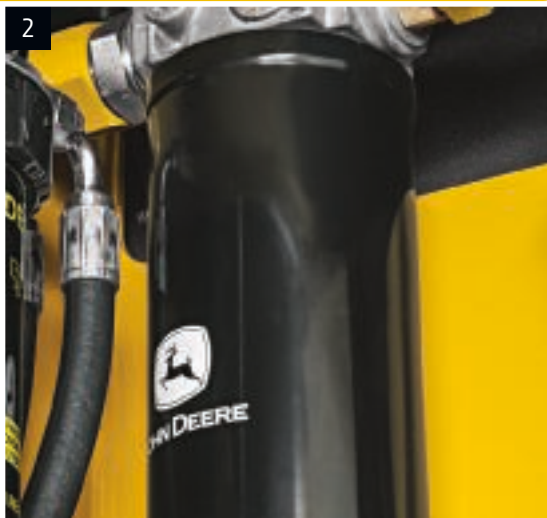



# 450J

| Engine                                    | 450J LT  |   | 450J LGP   |   |
|---|--|---|--|---|
| Manufacturer and Model                    | John Deere 4045H   | John Deere 4045T  | John Deere 4045H   | John Deere 4045T  |
| Non-Road Emission Standard                | EPA Tier 3/EU Stage IIIA   | EPA Tier 2/EU Stage II  | EPA Tier 3/EU Stage IIIA                                   | EPA Tier 2/EU Stage II  |
| Cylinders                                 | 4  | 4   | 4  | 4   |
| Displacement                              | 4.5 L (276 cu. in.)  | 4.5 L (276 cu. in.)   | 4.5 L (276 cu. in.)  | 4.5 L (276 cu. in.)   |
| SAE Net Rated Power at 2,200 rpm          | 57 kW (77 hp)  | 52 kW (70 hp)   | 57 kW (77 hp)  | 55 kW (74 hp)   |
| Net Peak Torque at 1,200 rpm              | 341 Nm (251 lb.-ft.)   | 318 Nm (234 lb.-ft.)  | 341 Nm (251 lb.-ft.)                                       | 341 Nm (251 lb.-ft.)  |
| Aspiration                                | Altitude-compensating turbo-charger with charge-air cooler   | Altitude-compensating turbocharger                                    | Altitude-compensating turbo-charger with charge-air cooler | Altitude-compensating turbocharger                                    |
| Lubrication                               | N/A  | Pressure system with full-flow spin-on filter and oil-to-water cooler | N/A  | Pressure system with full-flow spin-on filter and oil-to-water cooler |
| Air Cleaner                               | Dual safety element dry type, evacuator valve  |   | Dual safety element dry type, evacuator valve              |   |
| Slope Operation (maximum angle)           | 45 deg.  | 45 deg.   | 45 deg.  | 45 deg.   |
| <b>Cooling</b>                            |  |   |  |   |
| Type                                      | Blower-type cooling fan  | Blower-type cooling fan   | Blower-type cooling fan                                    | Blower-type cooling fan   |
| Engine Coolant Rating                     | -37 deg. C (-34 deg. F)  | -37 deg. C (-34 deg. F)   | -37 deg. C (-34 deg. F)                                    | -37 deg. C (-34 deg. F)   |
| <b>Powertrain</b>                         |  |   |  |   |
| <b>450J LT / 450J LGP</b>                 |  |   |  |   |
| <b>Transmission</b>                       |  |   |  |   |
|   | Dual-path, electronic-controlled, hydrostatic drive; load-sensing, automatically adjusts speed and power to match changing load conditions; each track is powered by a variable-displacement piston pump and 2-speed motor combination; decelerator controls speed; transmission neutral lock with safety start switch ( <i>Tier 3/Stage IIIA only</i> ) |   |  |   |
| Travel Speeds (forward and reverse)       | 0–8.0 km/h (0–5.0 mph)   |   |  |   |
| <b>Steering</b>                           |  |   |  |   |
|   | Single-lever steering, direction control, and counter-rotation; full power turns and infinitely variable track speeds provide unlimited maneuverability and optimum control; hydrostatic steering eliminates steering clutches and brakes  |   |  |   |
| <b>Final Drives</b>                       |  |   |  |   |
|   | Heavy-duty triple-reduction final drives attach directly to the mainframe; isolated from track and dozer frame loads   |   |  |   |
| <b>Brakes</b>                             |  |   |  |   |
|   | Hydrostatic (dynamic) braking stops the machine whenever the direction-control lever is moved to neutral or the decelerator is depressed to the detent   |   |  |   |
| Service Parking                           | Hydrostatic braking when the direction-control lever is moved to neutral or the decelerator is depressed to the detent   |   |  |   |
|   | Wet, multi-disc applied automatically whenever the engine stops, the decelerator pedal is depressed to brake position, the unit is in neutral for 3 sec. with detected motion, or the park lock lever is in park position; machine cannot be driven with brake applied   |   |  |   |
| <b>Hydraulics</b>                         |  |   |  |   |
| Type                                      | Open-center hydraulic system with gear pump  |   |  |   |
| Pump Flow at 2,200 rpm                    | 56.8 L/min. (15 gpm)   |   |  |   |
| System Relief Pressure                    | 20 684 kPa (3,000 psi)   |   |  |   |
| Controls                                  | 3-function hydraulic valve with low-effort single-lever T-bar  |   |  |   |
| <b>Electrical</b>                         |  |   |  |   |
| Voltage                                   | 12 volt  |   |  |   |
| <b>Capacity</b>                           |  |   |  |   |
| Battery                                   | 950 CCA  |   |  |   |
| Reserve                                   | 190 min.   |   |  |   |
| Alternator Rating                         | 65 amp   |   |  |   |
| Standard Lights                           | 3 total: grille mounted (2) and rear mounted (1), and rear reflectors (2)  |   |  |   |
| <b>Undercarriage</b>                      |  |   |  |   |
| <b>450J LT</b>                            |  |   |  |   |
| <b>450J LGP</b>                           |  |   |  |   |
| <b>Tracks</b>                             |  |   |  |   |
|   | John Deere Dura-Trax™, deep-heat-treated, pins and bushings sealed for life; rollers and idlers permanently sealed and lubricated  |   |  |   |
| Track Gauge (standard)                    | 1448 mm (57 in.)   |   | 1651 mm (65 in.)   |   |
| Grouser Width (closed center, single bar) | 406 mm (16 in.)  |   | 610 mm (24 in.)  |   |
| Chain                                     | Sealed and lubricated  |   | Sealed and lubricated                                      |   |
| Shoes (each side)                         | 40   |   | 40   |   |
| Track Rollers (single flange, each side)  | 6  |   | 6  |   |





| Undercarriage (continued)   | 450J LT                                   |   |   |              | 450J LGP                                  |   |   |              |
|---|---|---|---|--------------|---|---|---|--------------|
|   | Tier 3/Stage IIIA                         |   | Tier 2/Stage II                           |              | Tier 3/Stage IIIA                         |   | Tier 2/Stage II                           |              |
| Undercarriage Track   | Standard                                  | Maximum Life                              | Standard                                  | Maximum Life | Standard                                  | Maximum Life                              | Standard                                  | Maximum Life |
| Track Length on Ground  | 2184 mm<br>(86 in.)                       | 2154 mm<br>(85 in.)                       | 2184 mm<br>(86 in.)                       | N/A          | 2184 mm<br>(86 in.)                       | 2154 mm<br>(85 in.)                       | 2184 mm<br>(86 in.)                       | N/A          |
| Ground Contact Area   | 17 755 cm <sup>2</sup><br>(2,752 sq. in.) | 17 484 cm <sup>2</sup><br>(2,710 sq. in.) | 17 755 cm <sup>2</sup><br>(2,752 sq. in.) | N/A          | 26 632 cm <sup>2</sup><br>(4,128 sq. in.) | 26 258 cm <sup>2</sup><br>(4,070 sq. in.) | 26 632 cm <sup>2</sup><br>(4,128 sq. in.) | N/A          |
| Ground Pressure   | 40.7 kPa<br>(5.90 psi)                    | 42.3 kPa<br>(6.10 psi)                    | 40.7 kPa<br>(5.90 psi)                    | N/A          | 29.3 kPa<br>(4.30 psi)                    | 30.1 kPa<br>(4.37 psi)                    | 29.3 kPa<br>(4.30 psi)                    | N/A          |
| Track Pitch   | 160 mm<br>(6.29 in.)                      | 171 mm<br>(6.73 in.)                      | 160 mm<br>(6.29 in.)                      | N/A          | 160 mm<br>(6.29 in.)                      | 171 mm<br>(6.73 in.)                      | 160 mm<br>(6.29 in.)                      | N/A          |
| <b>Serviceability</b>   | <b>450J LT / 450J LGP</b>                 |   |   |              |   |   |   |              |
| <b>Refill Capacities</b>  |   |   |   |              |   |   |   |              |
| Fuel Tank   | 178 L (47 gal.)                           |   |   |              |   |   |   |              |
| Cooling System with Recovery Tank   | 16 L (17 qt.)                             |   |   |              |   |   |   |              |
| Engine Oil with Filter  | 14 L (15 qt.)                             |   |   |              |   |   |   |              |
| Transmission Reservoir with Filter  | 43 L (11.3 gal.)                          |   |   |              |   |   |   |              |
| Final Drive (each)  | 6.6 L (7 qt.)                             |   |   |              |   |   |   |              |
| Hydraulic Reservoir and Filter  | 32.2 L (8.5 gal.)                         |   |   |              |   |   |   |              |
| <b>Operating Weights</b>  | <b>450J LT</b>                            |   |   |              | <b>450J LGP</b>                           |   |   |              |
| With Rollover Protective Structure (ROPS), Standard Equipment, Full Fuel Tank, and 79-kg (175 lb.) Operator |   |   |   |              |   |   |   |              |
| 2464-mm (97 in.) Blade and 406-mm (16 in.) Track Shoes  | Tier 3/Stage IIIA<br>7386 kg (16,283 lb.) |   | Tier 2/Stage II<br>7386 kg (16,283 lb.)   |              | Tier 3/Stage IIIA<br>N/A                  |   | Tier 2/Stage II<br>N/A                    |              |
| 3150-mm (124 in.) Blade and 610-mm (24 in.) Track Shoes   | N/A                                       |   | N/A                                       |              | 7949 kg (17,525 lb.)                      |   | 7949 kg (17,525 lb.)                      |              |
| <b>Optional Components</b>  |   |   |   |              |   |   |   |              |
| Maximum Life Undercarriage  | 132 kg (290 lb.)                          |   | N/A                                       |              | 132 kg (290 lb.)                          |   | N/A                                       |              |
| Rock Guards (4)   | 117 kg (257 lb.)                          |   | 117 kg (257 lb.)                          |              | 131 kg (288 lb.)                          |   | 131 kg (288 lb.)                          |              |
| For Maximum Life Undercarriage  | 88 kg (193 lb.)                           |   | N/A                                       |              | 88 kg (193 lb.)                           |   | N/A                                       |              |
| Cab   | 306 kg (675 lb.)                          |   | 306 kg (675 lb.)                          |              | 306 kg (675 lb.)                          |   | 306 kg (675 lb.)                          |              |
| <b>Counterweight</b>  |   |   |   |              |   |   |   |              |
| Rear (each)   | 150 kg (330 lb.)                          |   | 150 kg (330 lb.)                          |              | 150 kg (330 lb.)                          |   | 150 kg (330 lb.)                          |              |
| Front (each)  | 109 kg (240 lb.)                          |   | 109 kg (240 lb.)                          |              | 109 kg (240 lb.)                          |   | 109 kg (240 lb.)                          |              |
| Retrieval Hitch   | 23 kg (50 lb.)                            |   | 23 kg (50 lb.)                            |              | 23 kg (50 lb.)                            |   | 23 kg (50 lb.)                            |              |
| Extended Drawbar  | 33 kg (72 lb.)                            |   | 33 kg (72 lb.)                            |              | 33 kg (72 lb.)                            |   | 33 kg (72 lb.)                            |              |
| Limb Risers   | 104 kg (229 lb.)                          |   | 104 kg (229 lb.)                          |              | 104 kg (229 lb.)                          |   | 104 kg (229 lb.)                          |              |
| <b>Screens</b>  |   |   |   |              |   |   |   |              |
| Rear  | 34 kg (76 lb.)                            |   | 34 kg (76 lb.)                            |              | 34 kg (76 lb.)                            |   | 34 kg (76 lb.)                            |              |
| Side  | 43 kg (94 lb.)                            |   | 43 kg (94 lb.)                            |              | 43 kg (94 lb.)                            |   | 43 kg (94 lb.)                            |              |
| Front and Doors   | 81 kg (179 lb.)                           |   | 81 kg (179 lb.)                           |              | 81 kg (179 lb.)                           |   | 81 kg (179 lb.)                           |              |
| <b>Winch</b>  |   |   |   |              |   |   |   |              |
| 4000S   | 652 kg (1,437 lb.)                        |   | 652 kg (1,437 lb.)                        |              | 652 kg (1,437 lb.)                        |   | 652 kg (1,437 lb.)                        |              |
| Fairlead, 4-Roller  | 85 kg (187 lb.)                           |   | 85 kg (187 lb.)                           |              | 85 kg (187 lb.)                           |   | 85 kg (187 lb.)                           |              |
| Ripper, Parallelogram   | 981 kg (2,163 lb.)                        |   | 386 kg (850 lb.)                          |              | 981 kg (2,163 lb.)                        |   | 386 kg (850 lb.)                          |              |
| <b>All-Hydraulic Heavy-Duty C Frame</b>   |   |   |   |              |   |   |   |              |
| 2464-mm (97 in.) Blade  | 44 kg (96 lb.)                            |   | 44 kg (96 lb.)                            |              | N/A                                       |   | N/A                                       |              |
| 2921-mm (115 in.) Blade (adjust to base weight)   | N/A                                       |   | N/A                                       |              | 2 kg (5 lb.)                              |   | 2 kg (5 lb.)                              |              |
| Less Blade (adjust to base weight)  | -482 kg (-1,063 lb.)                      |   | -482 kg (-1,063 lb.)                      |              | -482 kg (-1,063 lb.)                      |   | -482 kg (-1,063 lb.)                      |              |



| Machine Dimensions  | 450J LT                 | 450J LGP               |
|---|-------------------------|------------------------|
| A Overall Height (ROPS or cab)  | 2740 mm (9 ft. 0 in.)   | 2743 mm (9 ft. 0 in.)  |
| Height of Grousers  | 48.3 mm (1.9 in.)       | 48.0 mm (1.9 in.)      |
| B Overall Length  | 3940 mm (12 ft. 11 in.) | 4013 mm (13 ft. 2 in.) |
| C Overall Length with Extended Drawbar                                | 4110 mm (13 ft. 6 in.)  | 4064 mm (13 ft. 4 in.) |
| D Overall Length with Winch   | 4500 mm (14 ft. 9 in.)  | 4496 mm (14 ft. 9 in.) |
| E Ground Clearance with Single-Bar Grouser (excluding grouser height) | 345 mm (13.6 in.)       | 345 mm (13.6 in.)      |
| F Blade Lift Height   | 772 mm (30.4 in.)       | 772 mm (30.4 in.)      |
| G Blade Digging Depth   | 528 mm (20.8 in.)       | 528 mm (20.8 in.)      |
| H Blade Cutting-Edge Angle (adjustable)                               | 52 to 60 deg.           | 52 to 60 deg.          |

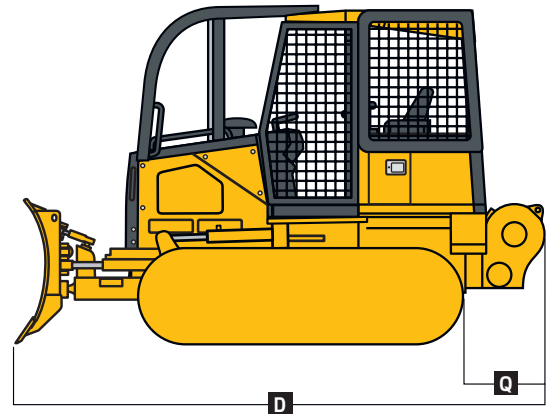
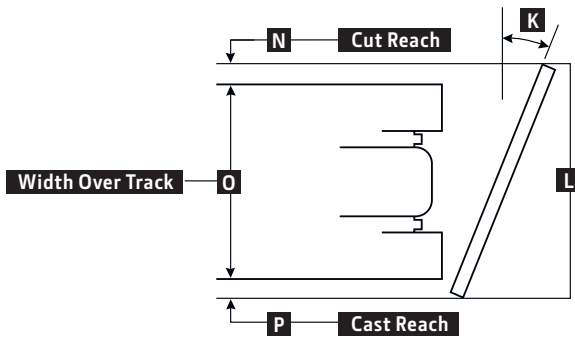
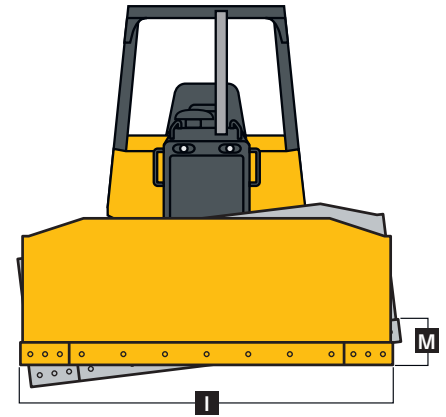
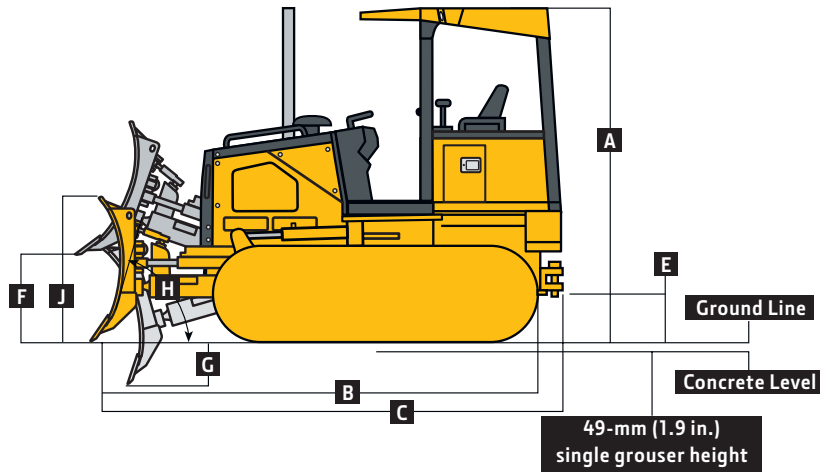

| Blade Specs        | 450J LT                            | 450J LGP                           |
|--------------------|------------------------------------|------------------------------------|
| I Width            | 2464 mm (97 in.)                   | 2921 mm (115 in.)                  |
| J Height           | 955 mm (3 ft. 2 in.)               | 955 mm (3 ft. 2 in.)               |
| SAE Capacity       | 1.64 m <sup>3</sup> (2.14 cu. yd.) | 1.96 m <sup>3</sup> (2.57 cu. yd.) |
| K Blade Angle      | 25.4 deg.                          | 25.4 deg.                          |
| L Angled Width     | 2225 mm (7 ft. 4 in.)              | 2639 mm (8 ft. 8 in.)              |
| M Tilt             | 338 mm (13.3 in.)                  | 399 mm (15.7 in.)                  |
| N Cut Reach        | 56 mm (2.2 in.)                    | 262 mm (10.3 in.)                  |
| O Width Over Track | 1854 mm (6 ft. 1 in.)              | 2261 mm (7 ft. 5 in.)              |
| P Cast Reach       | 318 mm (12.5 in.)                  | 523 mm (20.6 in.)                  |



| Rear Ripper |  | 450J LT / 450J LGP |
|-------------|--|--------------------|
| Q           | 4000S Winch Length                         | 752 mm (30 in.)    |
| R           | Maximum Penetration                        | 508 mm (20 in.)    |
| S           | Maximum Clearance Under Tip                | 508 mm (20 in.)    |
| T           | Overall Length (lowered position)          | 1450 mm (57 in.)   |
| Tl          | Overall Length (raised position)           | 1015 mm (40 in.)   |
| U           | Overall Beam Width                         | 1830 mm (72 in.)   |
| V           | Slope Angle (full raise)                   | 40 deg.            |
| W           | Ripping Width                              | 1670 mm (66 in.)   |
| X           | Distance Between Shanks (3 installed)      | 806 mm (32 in.)    |
|             | Distance Between Holes in 2-Position Shank | 80 mm (3.1 in.)    |

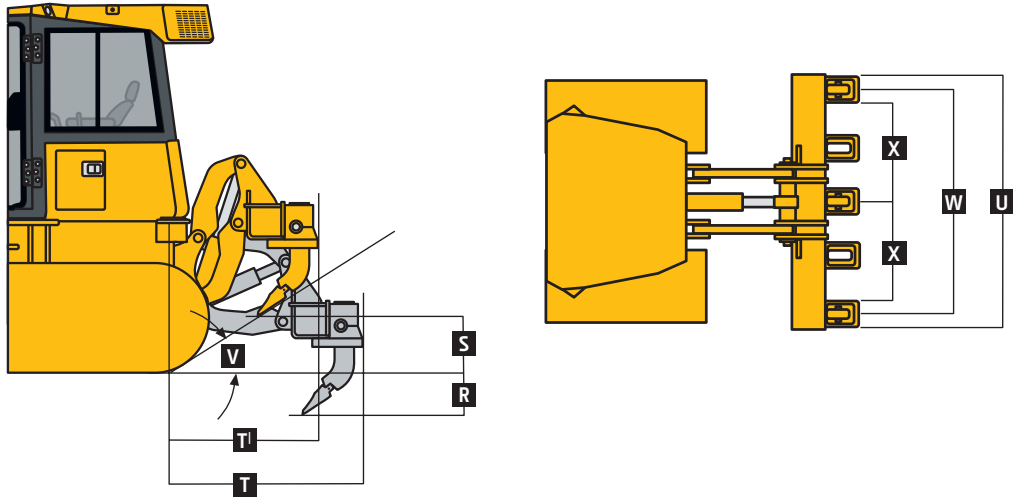

**Drawbar Pull** 450J LT / 450J LGP  
 Crawler Speed vs. Ground Pull Usable pull will depend on traction and weight of tractor

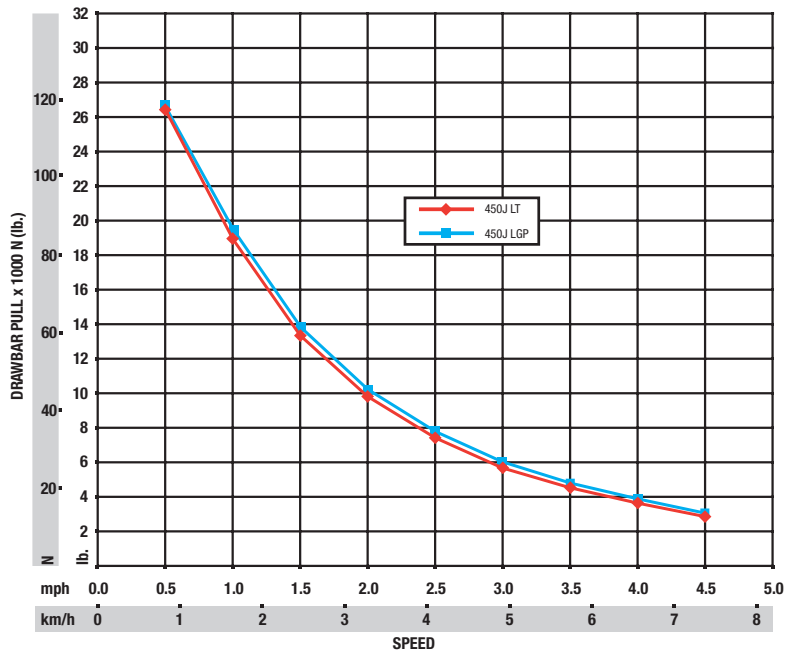



# 550J

| Engine                                    | 550J LT  |                                    | 550J LGP  |                                    |
|---|--|------------------------------------|---|------------------------------------|
| Manufacturer and Model                    | John Deere 4045H   | John Deere 4045T                   | John Deere 4045H  | John Deere 4045T                   |
| Non-Road Emission Standard                | EPA Tier 3/EU Stage IIIA   | EPA Tier 2/EU Stage II             | EPA Tier 3/EU Stage IIIA  | EPA Tier 2/EU Stage II             |
| Cylinders                                 | 4  | 4                                  | 4   | 4                                  |
| Displacement                              | 4.5 L (276 cu. in.)  | 4.5 L (276 cu. in.)                | 4.5 L (276 cu. in.)   | 4.5 L (276 cu. in.)                |
| SAE Net Rated Power at 2,200 rpm          | 63 kW (85 hp)  | 60 kW (80 hp)                      | 63 kW (85 hp)   | 63 kW (84 hp)                      |
| Net Peak Torque at 1,200 rpm              | 375 Nm (276 lb.-ft.)   | 358 Nm (263 lb.-ft.)               | 375 Nm (276 lb.-ft.)  | 375 Nm (276 lb.-ft.)               |
| Aspiration                                | Altitude-compensating turbo-charger with charge-air cooler   | Altitude-compensating turbocharger | Altitude-compensating turbo-charger with charge-air cooler            | Altitude-compensating turbocharger |
| Lubrication                               | Pressure system with full-flow spin-on filter and oil-to-water cooler  |                                    | Pressure system with full-flow spin-on filter and oil-to-water cooler |                                    |
| Air Cleaner                               | Dual safety element dry type, evacuator valve  |                                    | Dual safety element dry type, evacuator valve                         |                                    |
| Slope Operation (maximum angle)           | 45 deg.  | 45 deg.                            | 45 deg.   | 45 deg.                            |
| <b>Cooling</b>                            |  |                                    |   |                                    |
| Type                                      | Blower-type cooling fan  | Blower-type cooling fan            | Blower-type cooling fan   | Blower-type cooling fan            |
| Engine Coolant Rating                     | -37 deg. C (-34 deg. F)  | -37 deg. C (-34 deg. F)            | -37 deg. C (-34 deg. F)   | -37 deg. C (-34 deg. F)            |
| <b>Powertrain</b>                         |  |                                    |   |                                    |
| <b>550J LT / 550J LGP</b>                 |  |                                    |   |                                    |
| <b>Transmission</b>                       | Dual-path, electronic-controlled, hydrostatic drive; load-sensing, automatically adjusts speed and power to match changing load conditions; each track is powered by a variable-displacement piston pump and 2-speed motor combination; decelerator controls speed; transmission neutral lock with safety start switch ( <i>Tier 3/Stage IIIA only</i> )   |                                    |   |                                    |
| Travel Speeds (forward and reverse)       | 0–8.0 km/h (0–5.0 mph)   |                                    |   |                                    |
| <b>Steering</b>                           | Single-lever steering, direction control, and counter-rotation; full power turns and infinitely variable track speeds provide unlimited maneuverability and optimum control; hydrostatic steering eliminates steering clutches and brakes  |                                    |   |                                    |
| <b>Final Drives</b>                       | Heavy-duty triple-reduction final drives attach directly to the mainframe; isolated from track and dozer frame loads   |                                    |   |                                    |
| <b>Brakes</b>                             | Hydrostatic (dynamic) braking stops the machine whenever the direction-control lever is moved to neutral or the decelerator is depressed to the detent   |                                    |   |                                    |
| Service Parking                           | Hydrostatic braking when the direction-control lever is moved to neutral or the decelerator is depressed to the detent<br>Wet, multi-disc applied automatically whenever the engine stops, the decelerator pedal is depressed to brake position, the unit is in neutral for 3 sec. with detected motion, or the park lock lever is in park position; machine cannot be driven with brake applied |                                    |   |                                    |
| <b>Hydraulics</b>                         |  |                                    |   |                                    |
| Type                                      | Open-center hydraulic system with gear pump  |                                    |   |                                    |
| Pump Flow at 2,200 rpm                    | 56.8 L/min. (15 gpm)   |                                    |   |                                    |
| System Relief Pressure                    | 20 684 kPa (3,000 psi)   |                                    |   |                                    |
| Controls                                  | 3-function hydraulic valve with low-effort single-lever T-bar  |                                    |   |                                    |
| <b>Electrical</b>                         |  |                                    |   |                                    |
| Voltage                                   | 12 volt  |                                    |   |                                    |
| Capacity                                  |  |                                    |   |                                    |
| Battery                                   | 950 CCA  |                                    |   |                                    |
| Reserve                                   | 190 min.   |                                    |   |                                    |
| Alternator Rating                         | 65 amp   |                                    |   |                                    |
| <b>Standard Lights</b>                    | 3 total: grille mounted (2) and rear mounted (1), and rear reflectors (2)  |                                    |   |                                    |
| <b>Undercarriage</b>                      |  |                                    |   |                                    |
| <b>550J LT</b>                            |  |                                    |   |                                    |
| <b>Tracks</b>                             | John Deere Dura-Trax™, deep-heat-treated, pins and bushings sealed for life; rollers and idlers permanently sealed and lubricated  |                                    |   |                                    |
| Track Gauge (standard)                    | 1549 mm (61 in.)   |                                    | 1753 mm (69 in.)  |                                    |
| Grouser Width (closed center, single bar) | 457 mm (18 in.)  |                                    | 610 mm (24 in.)   |                                    |
| Chain                                     | Sealed and lubricated  |                                    | Sealed and lubricated   |                                    |
| Shoes (each side)                         | 40   |                                    | 40  |                                    |
| Track Rollers (single flange, each side)  | 6  |                                    | 6   |                                    |





| <b>Undercarriage (continued)</b>  | <b>550J LT</b>                            |   |   |                     | <b>550J LGP</b>                           |   |   |                     |
|---|---|---|---|---------------------|---|---|---|---------------------|
|   | <i>Tier 3/Stage IIIA</i>                  |   | <i>Tier 2/Stage II</i>                    |                     | <i>Tier 3/Stage IIIA</i>                  |   | <i>Tier 2/Stage II</i>                    |                     |
| <b>Undercarriage Track</b>  | <i>Standard</i>                           | <i>Maximum Life</i>                       | <i>Standard</i>                           | <i>Maximum Life</i> | <i>Standard</i>                           | <i>Maximum Life</i>                       | <i>Standard</i>                           | <i>Maximum Life</i> |
| Track Length on Ground  | 2184 mm<br>(86 in.)                       | 2154 mm<br>(85 in.)                       | 2184 mm<br>(86 in.)                       | N/A                 | 2184 mm<br>(86 in.)                       | 2154 mm<br>(85 in.)                       | 2184 mm<br>(86 in.)                       | N/A                 |
| Ground Contact Area   | 19 974 cm <sup>2</sup><br>(3,096 sq. in.) | 19 677 cm <sup>2</sup><br>(3,050 sq. in.) | 19 974 cm <sup>2</sup><br>(3,096 sq. in.) | N/A                 | 26 632 cm <sup>2</sup><br>(4,128 sq. in.) | 26 258 cm <sup>2</sup><br>(4,070 sq. in.) | 26 632 cm <sup>2</sup><br>(4,128 sq. in.) | N/A                 |
| Ground Pressure   | 37.9 kPa<br>(5.5 psi)                     | 39.1 kPa<br>(5.7 psi)                     | 37.9 kPa<br>(5.5 psi)                     | N/A                 | 29.0 kPa<br>(4.2 psi)                     | 31.4 kPa<br>(4.6 psi)                     | 29.0 kPa<br>(4.2 psi)                     | N/A                 |
| Track Pitch   | 160 mm<br>(6.29 in.)                      | 171 mm<br>(6.73 in.)                      | 160 mm<br>(6.29 in.)                      | N/A                 | 160 mm<br>(6.29 in.)                      | 171 mm<br>(6.73 in.)                      | 160 mm<br>(6.29 in.)                      | N/A                 |
| <b>Serviceability</b>   | <b>550J LT / 550J LGP</b>                 |   |   |                     |   |   |   |                     |
| <b>Refill Capacities</b>  |   |   |   |                     |   |   |   |                     |
| Fuel Tank   | 178 L (47 gal.)                           |   |   |                     |   |   |   |                     |
| Cooling System with Recovery Tank   | 16 L (17 qt.)                             |   |   |                     |   |   |   |                     |
| Engine Oil with Filter  | 14 L (15 qt.)                             |   |   |                     |   |   |   |                     |
| Transmission Reservoir with Filter  | 43 L (11.3 gal.)                          |   |   |                     |   |   |   |                     |
| Final Drive (each)  | 6.6 L (7 qt.)                             |   |   |                     |   |   |   |                     |
| Hydraulic Reservoir and Filter  | 32.2 L (8.5 gal.)                         |   |   |                     |   |   |   |                     |
| <b>Operating Weights</b>  | <b>550J LT</b>                            |   |   |                     | <b>550J LGP</b>                           |   |   |                     |
| With Rollover Protective Structure (ROPS), Standard Equipment, Full Fuel Tank, and 79-kg (175 lb.) Operator |   |   |   |                     |   |   |   |                     |
| 2667-mm (105 in.) Blade and 457-mm (18 in.) Track Shoes   | <i>Tier 3/Stage IIIA</i>                  |   | <i>Tier 2/Stage II</i>                    |                     | <i>Tier 3/Stage IIIA</i>                  |   | <i>Tier 2/Stage II</i>                    |                     |
|   | 7718 kg (17,016 lb.)                      |   | 7718 kg (17,016 lb.)                      |                     | N/A                                       |   | N/A                                       |                     |
| 3150-mm (124 in.) Blade and 610-mm (24 in.) Track Shoes   | N/A                                       |   | N/A                                       |                     | 8279 kg (18,252 lb.)                      |   | 8279 kg (18,252 lb.)                      |                     |
| <b>Optional Components</b>  |   |   |   |                     |   |   |   |                     |
| Maximum Life Undercarriage  | 132 kg (290 lb.)                          |   | N/A                                       |                     | 132 kg (290 lb.)                          |   | N/A                                       |                     |
| Rock Guards (4)   | 131 kg (288 lb.)                          |   | 131 kg (288 lb.)                          |                     | 131 kg (288 lb.)                          |   | 131 kg (288 lb.)                          |                     |
| For Maximum Life Undercarriage  | 88 kg (193 lb.)                           |   | N/A                                       |                     | 88 kg (193 lb.)                           |   | N/A                                       |                     |
| Cab   | 306 kg (675 lb.)                          |   | 306 kg (675 lb.)                          |                     | 306 kg (675 lb.)                          |   | 306 kg (675 lb.)                          |                     |
| <b>Counterweight</b>  |   |   |   |                     |   |   |   |                     |
| Rear (each)   | 150 kg (330 lb.)                          |   | 150 kg (330 lb.)                          |                     | 150 kg (330 lb.)                          |   | 150 kg (330 lb.)                          |                     |
| Front (each)  | 109 kg (240 lb.)                          |   | 109 kg (240 lb.)                          |                     | 109 kg (240 lb.)                          |   | 109 kg (240 lb.)                          |                     |
| Front Tow Hook  | 15 kg (33 lb.)                            |   | N/A                                       |                     | 15 kg (33 lb.)                            |   | N/A                                       |                     |
| Retrieval Hitch   | 23 kg (50 lb.)                            |   | 23 kg (50 lb.)                            |                     | 23 kg (50 lb.)                            |   | 23 kg (50 lb.)                            |                     |
| Extended Drawbar  | 33 kg (72 lb.)                            |   | 33 kg (72 lb.)                            |                     | 33 kg (72 lb.)                            |   | 33 kg (72 lb.)                            |                     |
| Limb Risers   | 104 kg (229 lb.)                          |   | 104 kg (229 lb.)                          |                     | 104 kg (229 lb.)                          |   | 104 kg (229 lb.)                          |                     |
| <b>Screens</b>  |   |   |   |                     |   |   |   |                     |
| Rear  | 34 kg (76 lb.)                            |   | 34 kg (76 lb.)                            |                     | 34 kg (76 lb.)                            |   | 34 kg (76 lb.)                            |                     |
| Side  | 43 kg (94 lb.)                            |   | 43 kg (94 lb.)                            |                     | 43 kg (94 lb.)                            |   | 43 kg (94 lb.)                            |                     |
| Front and Doors   | 81 kg (179 lb.)                           |   | 81 kg (179 lb.)                           |                     | 81 kg (179 lb.)                           |   | 81 kg (179 lb.)                           |                     |
| <b>Winch</b>  |   |   |   |                     |   |   |   |                     |
| 4000S   | 652 kg (1,437 lb.)                        |   | 652 kg (1,437 lb.)                        |                     | 652 kg (1,437 lb.)                        |   | 652 kg (1,437 lb.)                        |                     |
| Fairlead, 4-Roller  | 85 kg (187 lb.)                           |   | 85 kg (187 lb.)                           |                     | 85 kg (187 lb.)                           |   | 85 kg (187 lb.)                           |                     |
| Ripper, Parallelogram   | 981 kg (2,163 lb.)                        |   | 386 kg (850 lb.)                          |                     | 981 kg (2,163 lb.)                        |   | 386 kg (850 lb.)                          |                     |
| <b>All-Hydraulic Heavy-Duty C Frame</b>   |   |   |   |                     |   |   |   |                     |
| 2464-mm (97 in.) Blade  | -68 kg (-151 lb.)                         |   | -68 kg (-151 lb.)                         |                     | N/A                                       |   | N/A                                       |                     |
| 2921-mm (115 in.) Blade (adjust to base weight)   | N/A                                       |   | N/A                                       |                     | -17 kg (-38 lb.)                          |   | -17 kg (-38 lb.)                          |                     |
| 3073-mm (121 in.) Blade (adjust to base weight)   | N/A                                       |   | N/A                                       |                     | 10 kg (22 lb.)                            |   | 10 kg (22 lb.)                            |                     |
| Less Blade (adjust to base weight)  | -550 kg (-1,212 lb.)                      |   | -550 kg (-1,212 lb.)                      |                     | -623 kg (-1,373 lb.)                      |   | -623 kg (-1,373 lb.)                      |                     |



| Machine Dimensions  | 550J LT                 | 550J LGP                |
|---|-------------------------|-------------------------|
| A Overall Height (ROPS or cab)  | 2743 mm (9 ft. 0 in.)   | 2743 mm (9 ft. 0 in.)   |
| Height of Grousers  | 48 mm (1.9 in.)         | 48 mm (1.9 in.)         |
| B Overall Length  | 4039 mm (13 ft. 3 in.)  | 4039 mm (13 ft. 3 in.)  |
| C Overall Length with Extended Drawbar                                | 4089 mm (13 ft. 5 in.)  | 4089 mm (13 ft. 5 in.)  |
| D Overall Length with Winch   | 4547 mm (14 ft. 11 in.) | 4547 mm (14 ft. 11 in.) |
| E Ground Clearance with Single-Bar Grouser (excluding grouser height) | 345 mm (13.6 in.)       | 345 mm (13.6 in.)       |
| F Blade Lift Height   | 798 mm (31 in.)         | 798 mm (31 in.)         |
| G Blade Digging Depth   | 523 mm (21 in.)         | 523 mm (20.6 in.)       |
| H Blade Cutting-Edge Angle (adjustable)                               | 52 to 60 deg.           | 52 to 60 deg.           |

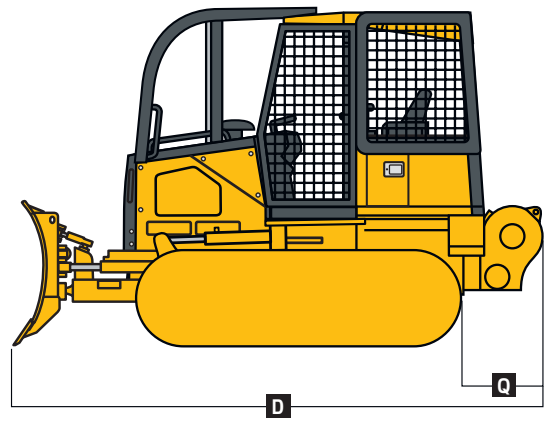
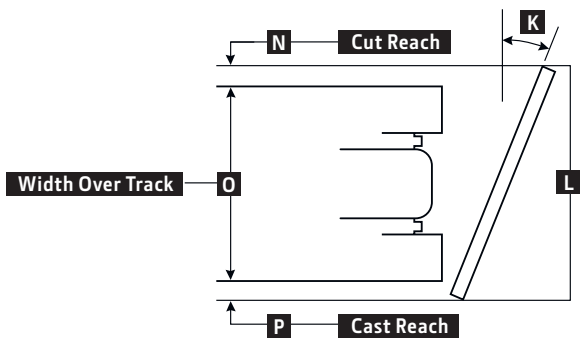
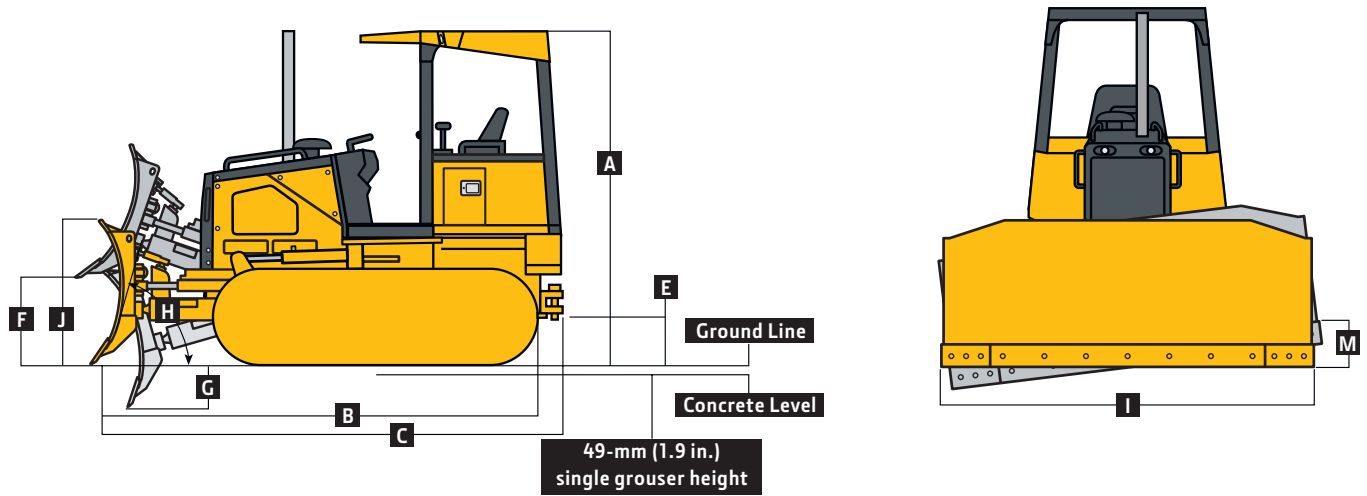

| Blade Specs        | 550J LT                            | 550J LGP                           |
|--------------------|------------------------------------|------------------------------------|
| I Width            | 2667 mm (105 in.)                  | 2921 mm (115 in.)                  |
| J Height           | 955 mm (3 ft. 2 in.)               | 955 mm (3 ft. 2 in.)               |
| SAE Capacity       | 1.80 m <sup>3</sup> (2.35 cu. yd.) | 1.96 m <sup>3</sup> (2.57 cu. yd.) |
| K Blade Angle      | 22.2 deg.                          | 22.2 deg.                          |
| L Angled Width     | 2469 mm (8 ft. 1 in.)              | 2705 mm (8 ft. 11 in.)             |
| M Tilt             | 363 mm (14.3 in.)                  | 399 mm (15.7 in.)                  |
| N Cut Reach        | 116.84 mm (4.6 in.)                | 233.68 mm (9.2 in.)                |
| O Width Over Track | 2007 mm (6 ft. 7 in.)              | 2362 mm (7 ft. 9 in.)              |
| P Cast Reach       | 345 mm (13.6 in.)                  | 465 mm (18.3 in.)                  |



| Rear Ripper    |                                       | 550J LT / 550J LGP |  |
|----------------|---------------------------------------|--------------------|--|
| Q              | 4000S Winch Length                    | 752 mm (30 in.)    |  |
| R              | Maximum Penetration                   | 508 mm (20 in.)    |  |
| S              | Maximum Clearance Under Tip           | 508 mm (20 in.)    |  |
| T              | Overall Length (lowered position)     | 1450 mm (57 in.)   |  |
| T <sup>l</sup> | Overall Length (raised position)      | 1015 mm (40 in.)   |  |
| U              | Overall Beam Width                    | 1830 mm (72 in.)   |  |
| V              | Slope Angle (full raise)              | 40 deg.            |  |
| W              | Ripping Width                         | 1670 mm (66 in.)   |  |
| X              | Distance Between Shanks (3 installed) | 806 mm (32 in.)    |  |
|                | Distance Between Holes in Shank       | 80 mm (3.1 in.)    |  |

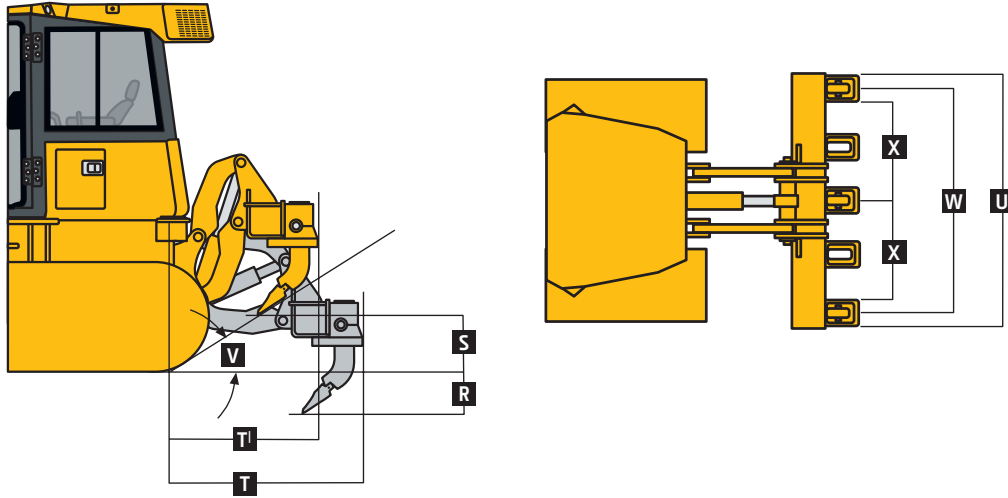

**Drawbar Pull** 550J LT / 550J LGP

Crawler Speed vs. Ground Pull

Usable pull will depend on traction and weight of tractor

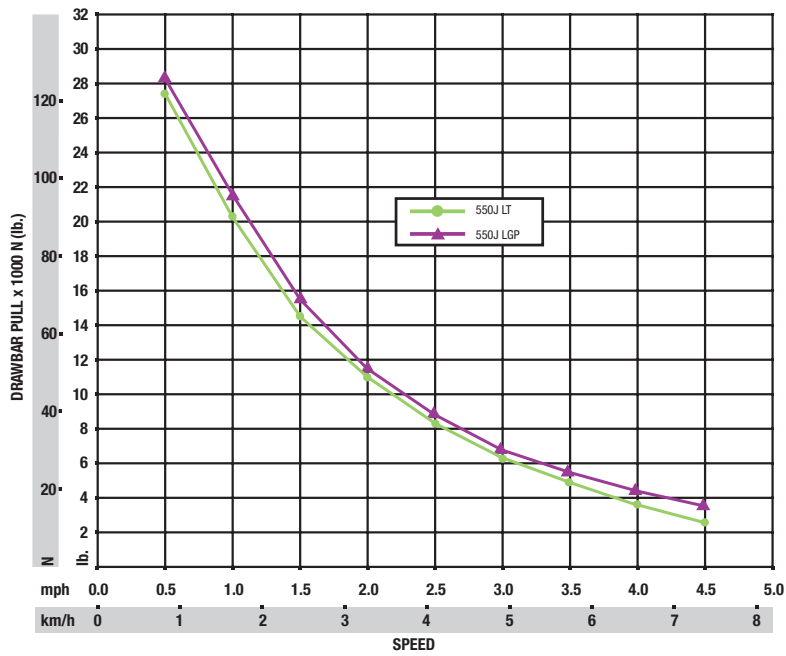







| <b>Undercarriage (continued)</b>  | <b>650J LT</b>                            |                       |   | <b>650J XLT</b>     |   |                       | <b>650J LGP</b>                           |                     |   |                       |   |                     |
|---|---|-----------------------|---|---------------------|---|-----------------------|---|---------------------|---|-----------------------|---|---------------------|
|   | <i>Tier 3/Stage IIIA</i>                  |                       | <i>Tier 2/Stage II</i>                    |                     | <i>Tier 3/Stage IIIA</i>                  |                       | <i>Tier 2/Stage II</i>                    |                     | <i>Tier 3/Stage IIIA</i>                  |                       | <i>Tier 2/Stage II</i>                    |                     |
| <b>Undercarriage Track</b>  | <i>Standard</i>                           | <i>Maximum Life</i>   | <i>Standard</i>                           | <i>Maximum Life</i> | <i>Standard</i>                           | <i>Maximum Life</i>   | <i>Standard</i>                           | <i>Maximum Life</i> | <i>Standard</i>                           | <i>Maximum Life</i>   | <i>Standard</i>                           | <i>Maximum Life</i> |
| Track Length on Ground  | 2210 mm (87 in.)                          |                       | 2210 mm (87 in.)                          |                     | 2337 mm (92 in.)                          |                       | 2337 mm (92 in.)                          |                     | 2337 mm (92 in.)                          |                       | 2337 mm (92 in.)                          |                     |
| Ground Contact Area   | 20 206 cm <sup>2</sup><br>(3,132 sq. in.) |                       | 20 206 cm <sup>2</sup><br>(3,132 sq. in.) |                     | 21 368 cm <sup>2</sup><br>(3,312 sq. in.) |                       | 21 368 cm <sup>2</sup><br>(3,312 sq. in.) |                     | 33 239 cm <sup>2</sup><br>(5,152 sq. in.) |                       | 33 239 cm <sup>2</sup><br>(5,152 sq. in.) |                     |
| Ground Pressure   | 40.7 kPa<br>(5.9 psi)                     | 42.1 kPa<br>(6.1 psi) | 40.7 kPa<br>(5.9 psi)                     | N/A                 | 38.6 kPa<br>(5.6 psi)                     | 40.0 kPa<br>(5.8 psi) | 38.6 kPa<br>(5.6 psi)                     | N/A                 | 26.2 kPa<br>(3.8 psi)                     | 27.6 kPa<br>(4.0 psi) | 26.2 kPa<br>(3.8 psi)                     | N/A                 |
| Track Pitch   | 171 mm (6.73 in.)                         |                       | 171 mm (6.73 in.)                         |                     | 171 mm (6.73 in.)                         |                       | 171 mm (6.73 in.)                         |                     | 171 mm (6.73 in.)                         |                       | 171 mm (6.73 in.)                         |                     |
| <b>Serviceability</b>   | <b>650J LT / 650J XLT / 650J LGP</b>      |                       |   |                     |   |                       |   |                     |   |                       |   |                     |
| <b>Refill Capacities</b>  |   |                       |   |                     |   |                       |   |                     |   |                       |   |                     |
| Fuel Tank   | 178 L (47 gal.)                           |                       |   |                     |   |                       |   |                     |   |                       |   |                     |
| Cooling System with Recovery Tank   | 16 L (17 qt.)                             |                       |   |                     |   |                       |   |                     |   |                       |   |                     |
| Engine Oil with Filter  | 14 L (15 qt.)                             |                       |   |                     |   |                       |   |                     |   |                       |   |                     |
| Transmission Reservoir with Filter  | 43 L (11.3 gal.)                          |                       |   |                     |   |                       |   |                     |   |                       |   |                     |
| Final Drive (each)  | 6.6 L (7 qt.)                             |                       |   |                     |   |                       |   |                     |   |                       |   |                     |
| Hydraulic Reservoir and Filter  | 32.2 L (8.5 gal.)                         |                       |   |                     |   |                       |   |                     |   |                       |   |                     |
| <b>Operating Weights</b>  | <b>650J LT</b>                            |                       |   | <b>650J XLT</b>     |   |                       | <b>650J LGP</b>                           |                     |   |                       |   |                     |
| With Rollover Protective Structure (ROPS), Standard Equipment, Full Fuel Tank, and 79-kg (175 lb.) Operator | <i>Tier 3/Stage IIIA</i>                  |                       | <i>Tier 2/Stage II</i>                    |                     | <i>Tier 3/Stage IIIA</i>                  |                       | <i>Tier 2/Stage II</i>                    |                     | <i>Tier 3/Stage IIIA</i>                  |                       | <i>Tier 2/Stage II</i>                    |                     |
| 2667-mm (105 in.) Blade and 457-mm (18 in.) Track Shoes   | 8419 kg (18,560 lb.)                      |                       | 8419 kg (18,560 lb.)                      |                     | 8455 kg (18,600 lb.)                      |                       | 8455 kg (18,600 lb.)                      |                     | N/A                                       |                       | N/A                                       |                     |
| 3251-mm (128 in.) Blade and 711-mm (28 in.) Track Shoes   | N/A                                       |                       | N/A                                       |                     | N/A                                       |                       | N/A                                       |                     | 8977 kg (19,750 lb.)                      |                       | 8977 kg (19,750 lb.)                      |                     |
| <b>Optional Components</b>  |   |                       |   |                     |   |                       |   |                     |   |                       |   |                     |
| Maximum Life Undercarriage  | 277 kg (610 lb.)                          |                       | N/A                                       |                     | 295 kg (650 lb.)                          |                       | N/A                                       |                     | 333 kg (735 lb.)                          |                       | N/A                                       |                     |
| Rock Guards (4)   | 118 kg (260 lb.)                          |                       | 118 kg (260 lb.)                          |                     | 134 kg (295 lb.)                          |                       | 134 kg (295 lb.)                          |                     | 118 kg (260 lb.)                          |                       | 118 kg (260 lb.)                          |                     |
| For Maximum Life Undercarriage  | 82 kg (181 lb.)                           |                       | N/A                                       |                     | 96 kg (211 lb.)                           |                       | N/A                                       |                     | 96 kg (211 lb.)                           |                       | N/A                                       |                     |
| Track Shoes   |   |                       |   |                     |   |                       |   |                     |   |                       |   |                     |
| 508 mm (20 in.)   | 79 kg (174 lb.)                           |                       | 79 kg (174 lb.)                           |                     | 83 kg (183 lb.)                           |                       | 83 kg (183 lb.)                           |                     | -344 kg (-760 lb.)                        |                       | -445 kg (-980 lb.)                        |                     |
| 610 mm (24 in.) (adjust to base weight)   | N/A                                       |                       | N/A                                       |                     | N/A                                       |                       | N/A                                       |                     | -172 kg (-380 lb.)                        |                       | -172 kg (-380 lb.)                        |                     |
| Cab   | 306 kg (675 lb.)                          |                       | 306 kg (675 lb.)                          |                     | 306 kg (675 lb.)                          |                       | 306 kg (675 lb.)                          |                     | 306 kg (675 lb.)                          |                       | 306 kg (675 lb.)                          |                     |
| Counterweight   |   |                       |   |                     |   |                       |   |                     |   |                       |   |                     |
| Rear (each)   | 150 kg (330 lb.)<br>in base               |                       | In base                                   |                     | 150 kg (330 lb.)                          |                       | 150 kg (330 lb.)                          |                     | 150 kg (330 lb.)                          |                       | 150 kg (330 lb.)                          |                     |
| Front (each)  | 109 kg (240 lb.)<br>in base               |                       | In base                                   |                     | 109 kg (240 lb.)                          |                       | 109 kg (240 lb.)                          |                     | 109 kg (240 lb.)                          |                       | 109 kg (240 lb.)                          |                     |
| Front Tow Hook  | In base                                   |                       | In base                                   |                     | In base                                   |                       | In base                                   |                     | In base                                   |                       | In base                                   |                     |
| Retrieval Hitch   | 23 kg (50 lb.)                            |                       | 23 kg (50 lb.)                            |                     | 23 kg (50 lb.)                            |                       | 23 kg (50 lb.)                            |                     | 23 kg (50 lb.)                            |                       | 23 kg (50 lb.)                            |                     |
| Extended Drawbar  | 33 kg (72 lb.)                            |                       | 33 kg (72 lb.)                            |                     | 33 kg (72 lb.)                            |                       | 33 kg (72 lb.)                            |                     | 33 kg (72 lb.)                            |                       | 33 kg (72 lb.)                            |                     |
| Limb Risers   | 104 kg (229 lb.)                          |                       | 104 kg (229 lb.)                          |                     | 104 kg (229 lb.)                          |                       | 104 kg (229 lb.)                          |                     | 104 kg (229 lb.)                          |                       | 104 kg (229 lb.)                          |                     |
| Screens   |   |                       |   |                     |   |                       |   |                     |   |                       |   |                     |
| Rear  | 34 kg (76 lb.)                            |                       | 34 kg (76 lb.)                            |                     | 34 kg (76 lb.)                            |                       | 34 kg (76 lb.)                            |                     | 34 kg (76 lb.)                            |                       | 34 kg (76 lb.)                            |                     |
| Side  | 43 kg (94 lb.)                            |                       | 43 kg (94 lb.)                            |                     | 43 kg (94 lb.)                            |                       | 43 kg (94 lb.)                            |                     | 43 kg (94 lb.)                            |                       | 43 kg (94 lb.)                            |                     |
| Front and Doors   | 81 kg (179 lb.)                           |                       | 81 kg (179 lb.)                           |                     | 81 kg (179 lb.)                           |                       | 81 kg (179 lb.)                           |                     | 81 kg (179 lb.)                           |                       | 81 kg (179 lb.)                           |                     |
| Winch   |   |                       |   |                     |   |                       |   |                     |   |                       |   |                     |
| 4000S   | 652 kg (1,437 lb.)                        |                       | 652 kg (1,437 lb.)                        |                     | 652 kg (1,437 lb.)                        |                       | 652 kg (1,437 lb.)                        |                     | 652 kg (1,437 lb.)                        |                       | 652 kg (1,437 lb.)                        |                     |
| Fairlead, 4-Roller  | 85 kg (187 lb.)                           |                       | 85 kg (187 lb.)                           |                     | 85 kg (187 lb.)                           |                       | 85 kg (187 lb.)                           |                     | 85 kg (187 lb.)                           |                       | 85 kg (187 lb.)                           |                     |
| Ripper, Parallelogram   | 981 kg (2,163 lb.)                        |                       | 592 kg (1,306 lb.)                        |                     | 981 kg (2,163 lb.)                        |                       | 592 kg (1,306 lb.)                        |                     | 981 kg (2,163 lb.)                        |                       | 592 kg (1,306 lb.)                        |                     |
| All-Hydraulic Heavy-Duty C Frame  |   |                       |   |                     |   |                       |   |                     |   |                       |   |                     |
| 2921-mm (115 in.) Blade (adjust to base weight)   | N/A                                       |                       | N/A                                       |                     | N/A                                       |                       | N/A                                       |                     | -61 kg (-134 lb.)                         |                       | -61 kg (-134 lb.)                         |                     |
| 3073-mm (121 in.) Blade (adjust to base weight)   | N/A                                       |                       | N/A                                       |                     | N/A                                       |                       | N/A                                       |                     | -33 kg (-74 lb.)                          |                       | -33 kg (-74 lb.)                          |                     |
| Less Blade  | -628 kg (-1,384 lb.)                      |                       | -628 kg (-1,384 lb.)                      |                     | -628 kg (-1,384 lb.)                      |                       | -628 kg (-1,384 lb.)                      |                     | -667 kg (-1,470 lb.)                      |                       | -667 kg (-1,470 lb.)                      |                     |

| Machine Dimensions   | 650J LT                 |                   | 650J XLT                |                   | 650J LGP                  |                            |
|--|-------------------------|-------------------|-------------------------|-------------------|---------------------------|----------------------------|
|  | Tier 3/Stage IIIA       | Tier 2/Stage II   | Tier 3/Stage IIIA       | Tier 2/Stage II   | Tier 3/Stage IIIA         | Tier 2/Stage II            |
| <b>A</b> Overall Height (ROPS or cab)  | 2769 mm (9 ft. 1 in.)   |                   | 2769 mm (9 ft. 1 in.)   |                   | 2769 mm (9 ft. 1 in.)     |                            |
| Height of Grousers   | 48 mm (1.9 in.)         | 48 mm (1.9 in.)   | 48 mm (1.9 in.)         | 48 mm (1.9 in.)   | 48.3 mm (1.9 in.)         | 48.3 mm (1.9 in.)          |
| <b>B</b> Overall Length  | 4089 mm (13 ft. 5 in.)  |                   | 4242 mm (13 ft. 11 in.) |                   | 4242 mm (13 ft. 11 in.)   |                            |
| <b>C</b> Overall Length with Extended Drawbar                                | 4216 mm (13 ft. 10 in.) |                   | 4293 mm (14 ft. 1 in.)  |                   | 4293 mm (14 ft. 1 in.)    |                            |
| <b>D</b> Overall Length with Winch   | 4547 mm (14 ft. 11 in.) |                   | 4724 mm (15 ft. 6 in.)  |                   | 4724 mm<br>(15 ft. 6 in.) | 4547 mm<br>(14 ft. 11 in.) |
| <b>E</b> Ground Clearance with Single-Bar Grouser (excluding grouser height) | 363 mm (14.0 in.)       | 363 mm (14.0 in.) | 363 mm (14.3 in.)       | 363 mm (14.3 in.) | 363 mm (14.3 in.)         | 363 mm (14.3 in.)          |
| <b>Maximum Life Undercarriage</b>  | 368 mm (14.5 in.)       | N/A               | 368 mm (14.5 in.)       | N/A               | 368 mm (14.5 in.)         | N/A                        |
| <b>F</b> Blade Lift Height   | 818 mm (32 in.)         | 818 mm (32 in.)   | 818 mm (32.2 in.)       | 818 mm (32.2 in.) | 818 mm (32.2 in.)         | 818 mm (32.2 in.)          |
| <b>G</b> Blade Digging Depth   | 500 mm (20 in.)         | 500 mm (20 in.)   | 500 mm (19.7 in.)       | 500 mm (19.7 in.) | 500 mm (19.7 in.)         | 500 mm (19.7 in.)          |
| <b>H</b> Blade Cutting-Edge Angle (adjustable)                               | 52 to 60 deg.           | 52 to 60 deg.     | 52 to 60 deg.           | 52 to 60 deg.     | 52 to 60 deg.             | 52 to 60 deg.              |

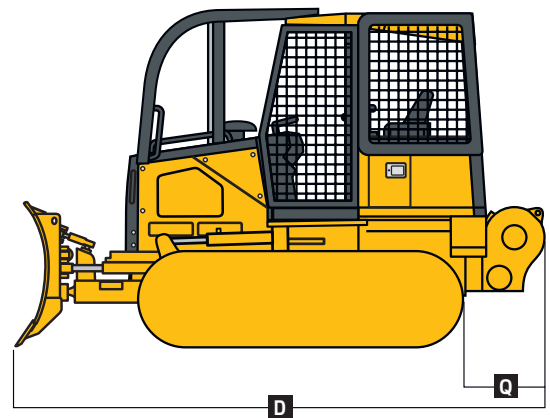
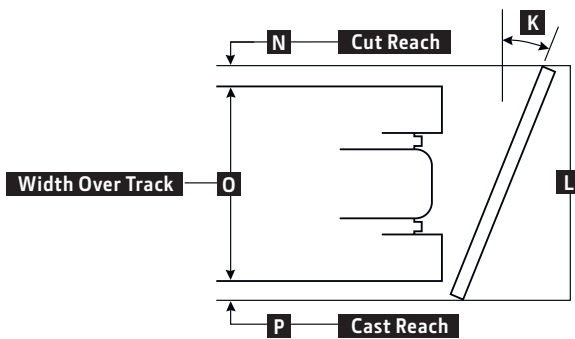
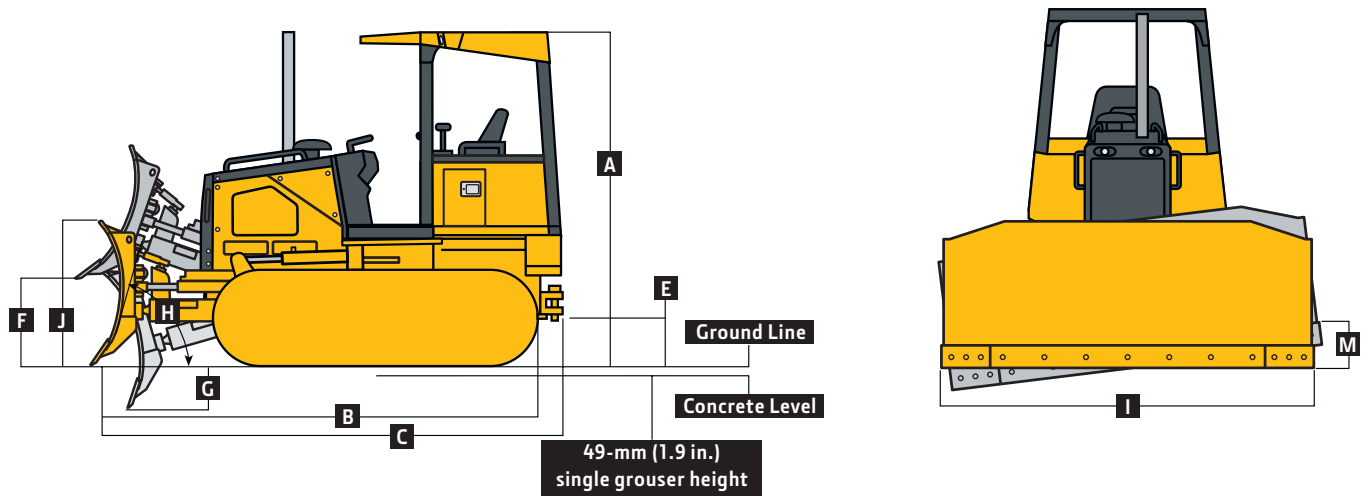

| Blade Specs               | 650J LT                               |                                       |                                       | 650J XLT                              |                                       |                                       | 650J LGP                              |                                       |                                       |
|---------------------------|---------------------------------------|---------------------------------------|---------------------------------------|---------------------------------------|---------------------------------------|---------------------------------------|---------------------------------------|---------------------------------------|---------------------------------------|
| <b>I</b> Width            | 2667 mm<br>(105 in.)                  | 2921 mm<br>(115 in.)                  | 3150 mm<br>(124 in.)                  | 2667 mm<br>(105 in.)                  | 2921 mm<br>(115 in.)                  | 3150 mm<br>(124 in.)                  | 2921 mm<br>(115 in.)                  | 3150 mm<br>(124 in.)                  | 3251 mm<br>(128 in.)                  |
| <b>J</b> Height           | 1067 mm<br>(3 ft. 6 in.)              | 955 mm<br>(3 ft. 2 in.)               | 894 mm<br>(35 in.)                    | 1067 mm<br>(3 ft. 6 in.)              | 955 mm<br>(3 ft. 2 in.)               | 894 mm<br>(35 in.)                    | 955 mm<br>(3 ft. 2 in.)               | 894 mm<br>(35 in.)                    | 955 mm<br>(3 ft. 2 in.)               |
| SAE Capacity              | 2.22 m <sup>3</sup><br>(2.91 cu. yd.) | 1.96 m <sup>3</sup><br>(2.57 cu. yd.) | 1.88 m <sup>3</sup><br>(2.46 cu. yd.) | 2.22 m <sup>3</sup><br>(2.91 cu. yd.) | 1.96 m <sup>3</sup><br>(2.57 cu. yd.) | 2.00 m <sup>3</sup><br>(2.46 cu. yd.) | 1.96 m <sup>3</sup><br>(2.57 cu. yd.) | 1.88 m <sup>3</sup><br>(2.46 cu. yd.) | 2.22 m <sup>3</sup><br>(2.91 cu. yd.) |
| <b>K</b> Blade Angle      | 22.2 deg.                             | 22.2 deg.                             | 22.2 deg.                             | 22.2 deg.                             | 22.2 deg.                             | 22.2 deg.                             | 22.2 deg.                             | 22.2 deg.                             | 22.2 deg.                             |
| <b>L</b> Angled Width     | 2469 mm<br>(8 ft. 1 in.)              | 2705 mm<br>(8 ft. 11 in.)             | 2916 mm<br>(9 ft. 7 in.)              | 2469 mm<br>(8 ft. 1 in.)              | 2705 mm<br>(8 ft. 11 in.)             | 2916 mm<br>(9 ft. 7 in.)              | 2705 mm<br>(8 ft. 11 in.)             | 2916 mm<br>(9 ft. 7 in.)              | 3010 mm<br>(9 ft. 11 in.)             |
| <b>M</b> Tilt             | 363 mm<br>(14.3 in.)                  | 399 mm<br>(15.7 in.)                  | 429 mm<br>(16.9 in.)                  | 363 mm<br>(14.3 in.)                  | 399 mm<br>(15.7 in.)                  | 429 mm<br>(16.9 in.)                  | 399 mm<br>(15.7 in.)                  | 429 mm<br>(16.9 in.)                  | 445 mm<br>(17.5 in.)                  |
| <b>N</b> Cut Reach        | 117.00 mm<br>(4.6 in.)                | 233.68 mm<br>(9.2 in.)                | 340.36 mm<br>(13.4 in.)               | 117.00 mm<br>(4.6 in.)                | 233.68 mm<br>(9.2 in.)                | 340.00 mm<br>(13.4 in.)               | 5.00 mm<br>(0.2 in.)                  | 112.00 mm<br>(4.4 in.)                | 157.00 mm<br>(6.2 in.)                |
| <b>O</b> Width Over Track | 2007 mm<br>(6 ft. 7 in.)              | 2007 mm<br>(6 ft. 7 in.)              | 2464 mm<br>(8 ft. 1 in.)*             | 2007 mm<br>(6 ft. 7 in.)              | 2007 mm<br>(6 ft. 7 in.)              | 2007 mm<br>(6 ft. 7 in.)              | 2464 mm<br>(8 ft. 1 in.)              | 2464 mm<br>(8 ft. 1 in.)              | 2464 mm<br>(8 ft. 1 in.)              |
| <b>P</b> Cast Reach       | 345 mm<br>(13.6 in.)                  | 465 mm<br>(18.3 in.)                  | 569 mm<br>(22.4 in.)                  | 345 mm<br>(13.6 in.)                  | 465 mm<br>(18.3 in.)                  | 569 mm<br>(22.4 in.)                  | 236 mm<br>(9.3 in.)                   | 340 mm<br>(13.4 in.)                  | 389 mm<br>(15.3 in.)                  |

\*2007-mm (6 ft. 7 in.) width over track for Tier 2/Stage II.



| Rear Ripper |                                       | 650J LT / 650J XLT / 650J LGP |
|-------------|---------------------------------------|-------------------------------|
| Q           | 4000S Winch Length                    | 752 mm (30 in.)               |
| R           | Maximum Penetration                   | 508 mm (20 in.)               |
| S           | Maximum Clearance Under Tip           | 508 mm (20 in.)               |
| T           | Overall Length (lowered position)     | 1450 mm (57 in.)              |
| Tl          | Overall Length (raised position)      | 1015 mm (40 in.)              |
| U           | Overall Beam Width                    | 1830 mm (72 in.)              |
| V           | Slope Angle (full raise)              | 40 deg.                       |
| W           | Ripping Width                         | 1670 mm (66 in.)              |
| X           | Distance Between Shanks (3 installed) | 806 mm (32 in.)               |
|             | Distance Between Holes in Shank       | 80 mm (3.1 in.)               |

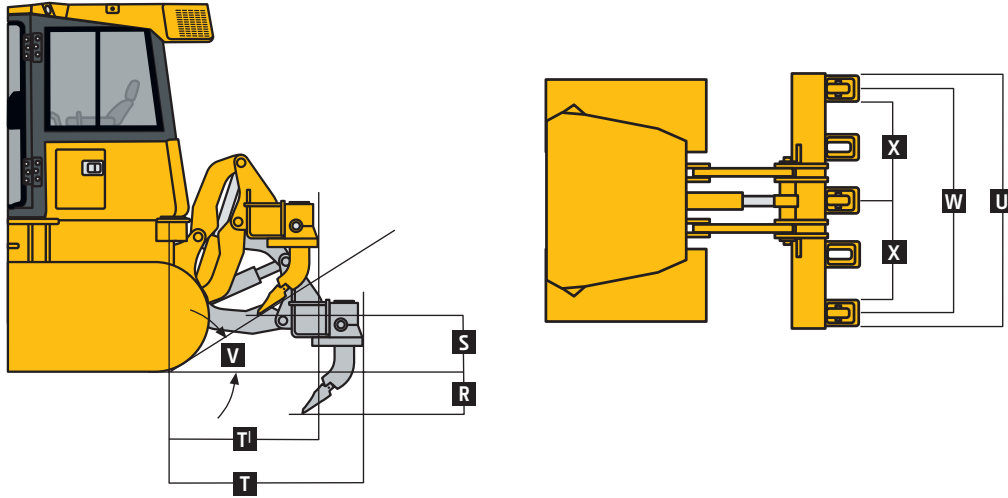

**Drawbar Pull** 650J LT / 650J XLT / 650J LGP  
 Crawler Speed vs. Ground Pull Usable pull will depend on traction and weight of tractor

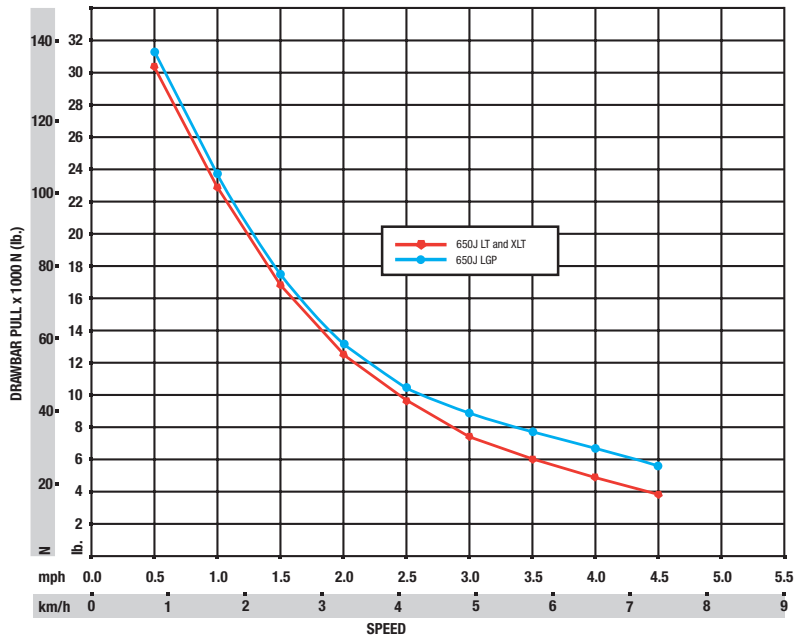

# Additional equipment

Key: ● Standard ▲ Optional or special

\*See your John Deere dealer for further information.

| 450J         | 550J | 650J | Engine  |
|--------------|------|------|---|
| ●            | ●    | ●    | Meets EPA Tier 3/EU Stage IIIA emissions                                      |
| ●            | ●    | ●    | Meets EPA Tier 2/EU Stage II emissions  |
| ●            | ●    | ●    | Electronic control with automatic engine protection                           |
| ●            | ●    | ●    | Dual safety element dry-type air cleaner, evacuator valve                     |
| ●            | ●    | ●    | Muffler, self-draining, under hood, with vertical stack                       |
| ▲            | ▲    | ▲    | Environmental service drains  |
| ▲            | ▲    | ▲    | Ether start aid   |
| ▲            | ▲    | ▲    | Engine coolant heater, 110 volts  |
| ▲            | ▲    | ▲    | Engine coolant heater, fuel fired   |
| ▲            | ▲    | ▲    | Chrome exhaust  |
| ▲            | ▲    | ▲    | Fuel filter heater  |
| ▲            | ▲    | ▲    | Rotary ejection engine air precleaner <sup>†</sup>                            |
| Cooling      |      |      |   |
| ●            | ●    | ●    | Cooling fan, blower type  |
| ●            | ●    | ●    | Engine coolant radiator (10 fins per 25 mm [1 in.])                           |
| ●            | ●    | ●    | Hydrostatic cooler and hydraulic cooler (oil/air – 10 fins per 25 mm [1 in.]) |
| ●            | ●    | ●    | Charge air cooler (air/air – 10 fins per 25 mm [1 in.]) <sup>†</sup>          |
|              |      | ●    | Charge air cooler (air/air – 7 fins per 25 mm [1 in.]) <sup>§</sup>           |
| ●            | ●    | ●    | Enclosed safety fan guard (conforms to SAE J1308 and ISO3457)                 |
| ●            | ●    | ●    | Perforated engine side shields  |
| ●            | ●    | ●    | Heavy-duty grille   |
| ▲            | ▲    | ▲    | Extreme-duty grille   |
| ▲            | ▲    | ▲    | Radiator sand screens <sup>§</sup>  |
| Transmission |      |      |   |
| ●            | ●    | ●    | Remote diagnostic test ports  |
| ▲            | ▲    | ▲    | Environmental service drains  |

| 450J                     | 550J | 650J | Hydraulic System   |
|--------------------------|------|------|--|
| ●                        | ●    | ●    | 3-function hydraulics  |
| ▲                        | ▲    | ▲    | 4-function hydraulics with rear plumbing   |
| ▲                        | ▲    | ▲    | Drive-through hydraulic pump for use with winch  |
|                          |      | ▲    | Integrated Grade Control (IGC)   |
| Mainframe, Access Panels |      |      |  |
| ●                        | ●    | ●    | Front tow loop (bolt-on)   |
| ●                        | ●    | ●    | Reinforced engine and mid-frame bottom guards  |
| ●                        | ●    | ●    | Integral transmission guard  |
| ●                        | ●    | ●    | Vandal protection: Engine access door / Side tank access doors / Fuel tank / Instrument panel / Transmission reservoir / Hydraulic reservoir |
| Attachments              |      |      |  |
| ▲                        | ▲    | ▲    | Retrieval hitch with pin   |
| ▲                        | ▲    | ▲    | Extended rigid drawbar with pin for pull-type implements   |
| ▲                        | ▲    | ▲    | Drawbar, extended for winch (with or without fairlead)   |
| ▲                        | ▲    | ▲    | Ripper, parallelogram with 5 shank pockets and 3 teeth   |
| ▲                        | ▲    | ▲    | Winch, John Deere, power in/ free spool out OR power out   |
| ▲                        | ▲    | ▲    | 4-roller fairlead for winch  |
| ▲                        | ▲    | ▲    | Root-rake blade attachment   |
| ▲                        | ▲    | ▲    | Rear-mounted toolbox   |
| Undercarriage            |      |      |  |
| ●                        | ●    | ●    | Full-length, smooth-surface track frame covers   |
| ●                        | ●    | ●    | Chain guides, front and rear   |
| ●                        | ●    |      | Single-flange roller   |
| ▲                        | ▲    | ●    | Double-flange rollers  |
| ▲                        | ▲    | ▲    | Full-length rock guards  |
|                          |      | ▲    | Center track chain guide   |
| ▲                        | ▲    | ▲    | Maximum Life Undercarriage System <sup>†</sup>   |
| ▲                        | ▲    | ▲    | Extended life undercarriage with SC-2™ bushings <sup>§</sup>   |

| Canopy | Cab | Operator's Station / Electrical  |
|--------|-----|--|
| ●      | ●   | Retractable seat belts, 51 mm (2 in.) (conform to SAE J386)  |
| ▲      | ▲   | Retractable seat belts, 76 mm (3 in.) (conform to SAE J386)  |
| ▲      | ▲   | Accessories: Convex wide-angle interior rearview mirror / Thigh cushions (2) / Seat-side lockable storage box/lunch box/cup holder |
| ●      | ●   | Power port, 12 volts   |
| ▲      | ▲   | Lockable side-seat storage compartment   |
|        | ●   | Air conditioner, 24,000 Btu  |
|        | ●   | Tinted glass   |
|        | ●   | Dome light   |
|        | ●   | Heater (roof mount)  |
|        | ●   | Front and door wipers  |
| ●      |     | Mechanical suspension vinyl seat   |
|        | ●   | Mechanical suspension fabric seat  |
| ▲      |     | Air suspension vinyl seat  |
|        | ▲   | Air suspension fabric seat   |
| ▲      |     | Under-seat heater  |
|        | ▲   | Rear wiper   |
|        | ▲   | AM/FM/Weather-Band radio/clock   |
|        | ▲   | External-mounted attachment mirror   |
| ●      | ●   | Sealed alternator, 65 amps   |
| ●      | ●   | Master electrical disconnect switch  |
| ●      | ●   | Lights, grille mounted (2), rear mounted (1)   |
| ▲      | ▲   | Work lights, roof mounted  |
| ●      | ●   | Battery, single, 12 volts  |
| ▲      | ▲   | Battery, dual, 12 volts  |
| ▲      | ▲   | JDLINK™ Ultimate wireless communication system (available in specific countries; see your dealer for details)                      |

<sup>†</sup>EPA Tier 3/EU Stage IIIA only.

<sup>§</sup>EPA Tier 2/EU Stage II only.

Actual machine configuration may differ from image. Not all models available in all countries.

Net engine power is with standard equipment including air cleaner, exhaust system, alternator, and cooling fan at test conditions specified per ISO9249. Specifications and design subject to change without notice. Wherever applicable, specifications are in accordance with SAE standards. Except where otherwise noted, these specifications are based on units with standard equipment, rollover protective structures, full fuel tanks, and 79-kg (175 lb.) operators.

