



**Operators and Safety Manual
Service & Maintenance Manual
Illustrated Parts Manual**

Models

AM-19

AM-24

AM-30

AM-36

AC & DC Models

3120596

January 1, 1998

ANSI



FOREWORD

The purpose of this manual is to provide users with the operating procedures essential for the promotion of proper machine operation for its intended purpose. It is important to over-stress proper machine usage. All information in this manual should be **READ** and **UNDERSTOOD** before any attempt is made to operate the machine. **YOUR OPERATING MANUAL IS YOUR MOST IMPORTANT TOOL** - Keep it with the machine. **REMEMBER ANY EQUIPMENT IS ONLY AS SAFE AS THE OPERATOR.**

BECAUSE THE MANUFACTURER HAS NO DIRECT CONTROL OVER MACHINE APPLICATION AND OPERATION, PROPER SAFETY PRACTICES ARE THE RESPONSIBILITY OF THE USER AND HIS OPERATING PERSONNEL.

ALL INSTRUCTIONS IN THIS MANUAL ARE BASED ON THE USE OF THE MACHINE UNDER PROPER OPERATING CONDITIONS, WITH NO DEVIATIONS FROM THE ORIGINAL DESIGN. ALTERATION AND/OR MODIFICATION OF THE MACHINE IS STRICTLY FORBIDDEN WITHOUT WRITTEN APPROVAL FROM JLG INDUSTRIES. PER OSHA REGULATIONS.



THIS "SAFETY ALERT SYMBOL" IS USED TO CALL ATTENTION TO POTENTIAL HAZARDS WHICH MAY LEAD TO DEATH OR SERIOUS INJURY IF IGNORED.

Safety of personnel and proper use of the machine are of primary concern, **DANGER, WARNING, CAUTION, IMPORTANT, INSTRUCTIONS** and **NOTE** are inserted throughout this manual to emphasize these areas. They are defined as follows:

DANGER

DANGER INDICATES AN IMMINENTLY HAZARDOUS SITUATION WHICH, IF NOT AVOIDED WILL RESULT IN DEATH OR SERIOUS INJURY.

WARNING

WARNING INDICATES A POTENTIALLY HAZARDOUS SITUATION WHICH, IF NOT AVOIDED COULD RESULT IN DEATH OR SERIOUS INJURY.

CAUTION

CAUTION INDICATES A POTENTIALLY HAZARDOUS SITUATION WHICH, IF NOT AVOIDED, MAY RESULT IN MINOR OR MODERATE INJURY. IT MAY ALSO BE USED TO ALERT AGAINST UNSAFE PRACTICES.

IMPORTANT

IMPORTANT OR INSTRUCTIONS PROCEDURES ESSENTIAL FOR SAFE OPERATION AND WHICH, IF NOT FOLLOWED MAY RESULT IN A MALFUNCTION OR DAMAGE TO THE MACHINE.

In this Manual "Notes" are used to provide information of special interest.

All procedures herein are based on the use of the machine under proper operating conditions, with no deviations from original design intent ... as per OSHA regulations.

READ & HEED!

The ownership, use, service, and/or maintenance of this machine is subject to various federal, state and local laws and regulations. It is the responsibility of the owner/user to be knowledgeable of these laws and regulations and to comply with them. The most prevalent regulations of this type are the Federal OSHA Safety Regulations*. Listed below, in abbreviated form are some of the requirements of Federal OSHA regulations in effect as of the date of publication of this handbook.

The listing of these requirements shall not relieve the owner/user of the responsibility and obligation to determine all applicable laws and regulations and their exact wording and requirements, and to comply with the requirements. Nor shall the listing of these requirements constitute an assumption of responsibility of liability on the part of JLG Industries, Inc.

1. Only trained and authorized operators shall be permitted to operate the aerial lift.
2. A malfunctioning lift shall be shut down until repaired.
3. The controls shall be plainly marked as to their function.
4. The controls shall be tested each day prior to use to determine that they are in safe operating condition.
5. Load limits specified by the manufacturer shall not be exceeded.
6. Instruction and warning placards must be legible.
7. Aerial lifts may be "field modified" for uses other than those intended by the manufacturer only if certified in writing by the manufacturer or an equivalent entity, such as a nationally recognized testing lab, to be in conformity to applicable OSHA safety regulations and to be at least as safe as it was prior to modification.
8. Aerial lifts shall not be used near electric power lines unless the lines have been deenergized or adequate clearance is maintained (see OSHA 29 CFR 1910.67 and 1926.400).
9. Employees using aerial lifts shall be instructed how to recognize and avoid unsafe conditions and hazards.
10. Ground controls shall not be operated unless permission has been obtained from personnel in the platform, except in case of an emergency.
11. Regular inspection of the job site and aerial lift shall be performed by competent persons.
12. Personnel shall always stand on the floor of the platform, not on boxes, planks, railing or other devices for a work position.

*Applicable Federal OSHA regulations, as of the date of publication of this manual include, but are not limited to, 29 CFR 1910.67, 29 CFR 1926.20, 29 CFR 1926.21, 29 CFR 1926.28, 29 CFR 1926.400 and 29 CFR 1926.556. Consult the current regulations for the exact wording and full text of the requirements and contact the closest Federal OSHA office for specific interpretations.

A. GENERAL

This section contains the general safety precautions which must be observed during maintenance of the aerial platform. It is of utmost importance that maintenance personnel pay strict attention to these warnings and precautions to avoid possible injury to themselves or others or damage to the equipment. A maintenance program must be established by a qualified person and must be followed to ensure that the machine is safe to operate.

⚠ WARNING

MODIFICATION OF THE MACHINE WITHOUT CERTIFICATION BY A RESPONSIBLE AUTHORITY THAT THE MACHINE IS AT LEAST AS SAFE AS ORIGINALLY MANUFACTURED IS A SAFETY VIOLATION.

The specific precautions to be observed during machine maintenance are inserted at the appropriate point in the manual. These precautions are, for the most part, those that apply when servicing hydraulic and larger machine component parts.

Your safety, and that of others, is the first consideration when engaging in the maintenance of equipment. Always be conscious of component weight and never attempt to move heavy parts without the aid of a mechanical device. Do not allow heavy objects to rest in an unstable position. When raising a portion of the equipment, ensure that adequate support is provided.

⚠ WARNING

SINCE THE MACHINE MANUFACTURER HAS NO DIRECT CONTROL OVER THE FIELD INSPECTION AND MAINTENANCE, SAFETY IN THIS AREA IS THE RESPONSIBILITY OF THE OWNER/OPERATOR.

B. HYDRAULIC SYSTEM SAFETY

1. It should be particularly noted that the machines hydraulic systems operate at extremely high and potentially dangerous pressures. Every effort should be made to relieve any system pressure prior to disconnecting or removing any portion of the system.
2. Relieve system pressure by activating the lift DOWN control with the platform completely lowered to direct any line pressure back into the return line to the reservoir. Pressure feed lines to system components can then be disconnected with minimal fluid loss.

C. MAINTENANCE**⚠ WARNING**

FAILURE TO COMPLY WITH SAFETY PRECAUTIONS LISTED IN THIS SECTION COULD RESULT IN MACHINE DAMAGE, PERSONNEL INJURY OR DEATH AND IS A SAFETY VIOLATION.

- REMOVE ALL RINGS, WATCHES, AND JEWELRY WHEN PERFORMING ANY MAINTENANCE.
- DO NOT WEAR LONG HAIR UNRESTRAINED, OR LOOSE FITTING CLOTHING AND NECKTIES WHICH ARE APT TO BECOME CAUGHT ON OR ENTANGLED IN EQUIPMENT.
- OBSERVE AND OBEY ALL DANGER, WARNING, CAUTION AND OTHER INSTRUCTIONS ON MACHINE AND IN SERVICE MANUAL.
- KEEP STANDING SURFACES AND HAND HOLDS FREE OF OIL, GREASE, WATER, ETC.
- NEVER WORK UNDER AN ELEVATED PLATFORM UNTIL SAFETY PROPS HAVE BEEN ENGAGED OR PLATFORM HAS BEEN SAFELY RESTRAINED FROM ANY MOVEMENT BY BLOCKING OR OVERHEAD SLING.
- BEFORE MAKING ADJUSTMENTS, LUBRICATING OR PERFORMING ANY OTHER MAINTENANCE, SHUT OFF ALL POWER CONTROLS.
- BATTERY SHOULD ALWAYS BE DISCONNECTED DURING REPLACEMENT OF ELECTRICAL COMPONENTS.
- KEEP ALL SUPPORT EQUIPMENT AND ATTACHMENTS STOWED IN THEIR PROPER PLACE.
- USE ONLY APPROVED, NONFLAMMABLE CLEANING SOLVENTS.

REVISION LOG

- October 14, 1994 — Original Issue of Manual
- January 1, 1995 — Revised - Added optional AM-SE Straddle Extension Kit - "Set-Up and Operation" to Section-5 and Parts Section. Added optional Fiberglass Platform to Parts Section. Also added procedure for setting height of outrigger socket contactor screws and outrigger beam contactor plate to Section-9.
- February 15, 1995 — Change 1 - Pages Affected:
 Cover
 Revision Log – Page c
 Table of Contents – Page ii
 Section 2 – Pages 2-3 and 2-4
 Section 3 – Pages 3-2 and 3-3
 Section 5 – Pages 5-4, 5-5, 5-6
 Section 7 – Page 7-1
 Section 10-1 – Pages 10-1-2 to 10-1-3B and 10-1-5
 Section 10-2 – Pages 10-2-2, 10-2-3, 10-2-9, 10-2-11 to 10-2-13 and 10-2-17
 Section 10-3 – Pages 10-3-3, 10-3-8 and 10-3-11
 Section 10-4 – Pages 10-4-2, 10-4-3 and 10-4-5
 Section 10-7 – Pages 10-7-2 to 10-7-4
 Section 10-8 – Pages 10-8-3 and 10-8-4
 Section 10-9 – Page 10-9-1
 Section 10-10 – Page 10-10-3
- June 1995 — Change 2 - Pages Affected:
 Cover
 Revision Log - Page c
 Section 10 Illustrated Parts Table of Contents - Page 10-0-1
 Section 10-1 — Pages 10-1-2 to 10-1-5
 Section 10-2 — Pages 10-2-7, 10-2-11, 10-2-17 and 10-2-18
 Section 10-3 — Pages 10-3-5, 10-3-8, 10-3-9 and 10-3-11
 Section 10-4 — Pages 10-4-2 to 10-4-5
 Section 10-7 — Pages 10-7-2 and 10-7-4
 Section 10-8 — Pages 10-8-2 to 10-8-4
 Section 10-10 — Pages 10-10-1 to 10-10-4
- May 1997 — Updated - Pages Affected:
 Table of Contents – Page ii
 Section 9 – Page 9-1, added Page 9-5 (Fig. 9-2.)
- January 1998 — Revised - Pages Affected:
 Section 10 Illustrated Parts

SUBJECT - SECTION, PARAGRAPH	PAGE NO.
INTRODUCTION - OPERATION SAFETY PRECAUTIONS	a
INTRODUCTION - MAINTENANCE SAFETY PRECAUTIONS	b
A. General	b
B. Hydraulic System Safety	b
C. Maintenance	b
EFFECTIVITY CHANGES	c
TABLE OF CONTENTS	i
LIST OF ILLUSTRATIONS	ii
LIST OF TABLES	ii
 SECTION 1 — SAFETY PRECAUTIONS	
1-1. General	1-1
1-2. Electrocution Hazard	1-1
1-3. Transporting	1-1
1-4. Transporting Safety	1-1
1-5. Pre-Operational Safety	1-2
1-6. Operation Safety	1-4
 SECTION 2 — PREPARATION AND INSPECTION	
2-1. General	2-1
2-2. Preparation For Use	2-1
2-3. Delivery and Periodic Inspection	2-1
2-4. Daily Walk-Around Inspection	2-2
2-5. Daily Functional Check	2-4
2-6. Torque Requirements	2-4
2-7. Battery Charging (DC Machines)	2-5
 SECTION 3 — USER RESPONSIBILITIES AND MACHINE CONTROLS	
3-1. General	3-1
3-2. Personnel Training	3-1
3-3. Operating Characteristics and Limitations	3-2
3-4. Controls and Indicators	3-2
 SECTION 4 — MACHINE OPERATION	
4-1. Machine Description	4-1
4-2. General	4-1
4-3. Machine Set-Up and Operation	4-2
4-4. Stowing Machine	4-3
4-5. Transporting and Lifting	4-4
 SECTION 5 — OPTIONAL EQUIPMENT	
5-1. Optional Equipment	5-1
5-2. AM-SE - Straddle Extension Kit - Set-Up and Operation	5-1
 SECTION 6 — EMERGENCY PROCEDURES	
6-1. General	6-1
6-2. Emergency Controls and Their Locations	6-1
6-3. Emergency Operation	6-1
6-4. Incident Notification	6-2
 SECTION 7 — SPECIFICATIONS	
7-1. Capacities	7-1
7-2. Component Data	7-1
7-3. Performance Data	7-1
7-4. Torque Requirements	7-2
7-5. Lubrication	7-2
7-6. Pressure Adjustment	7-2
7-7. Cylinder Specifications	7-2
7-8. Serial Number Locations	7-2

SUBJECT-SECTION, PARAGRAPH	PAGE NO.
SECTION 8 — PROCEDURES	
8-1. General	8-1
8-2. Servicing and Maintenance Guidelines	8-1
8-3. Lubrication Information	8-4
8-4. Mast Assembly and Disassembly Procedure	8-5
8-5. Mast to Base Frame Installation	8-13
8-6. Mast Chains and Sequencing Cables Adjustment	8-14
8-7. Preventive Maintenance and Inspection Schedule	8-14
SECTION 9 — TROUBLESHOOTING	
9-1. General	9-1
9-2. Troubleshooting Information	9-1
9-3. Hydraulic Circuit Checks	9-1
9-4. Outrigger Interlock Contacts	9-1
SECTION 10 — ILLUSTRATED PARTS MANUAL	
Illustrated Parts – Table of Contents	10-0-1

LIST OF ILLUSTRATIONS

FIGURE NO.	TITLE	PAGE NO.
1-1.	Pushing Machine on a Smooth, Firm Surface	1-2
1-2.	Pushing Machine on a Slope	1-3
2-1.	Daily Walk-Around Inspection	2-3
2-2.	Battery Box & Charger Assembly (DC models only)	2-5
3-1.	Ground Control Station	3-2
3-2.	Platform Control Station	3-3
4-1.	Outriggers Installed	4-2
4-2.	Pushing Machine on a Smooth, Firm Surface	4-4
4-3.	Pushing Machine on a Slope	4-5
4-4.	Tilt-Back Assembly Set-Up	4-6
4-5.	Loading Machine onto Pickup Truck for Transport	4-8
5-1.	Straddle Adaptor Wiring Harness Installation	5-2
5-2.	Straddle Adaptor - AC Control Box Wiring Connections	5-3
5-3.	Straddle Adaptor - DC Ground Control Station Wiring Connections	5-3
5-4.	Straddle Extension - Component Assembly	5-4
5-5.	Lowering AccessMaster on Straddle Unit - Side Lifting Rail Quick-Release Pins	5-6
7-1.	Torque Chart	7-3
7-2.	Lubrication Chart	7-4
8-1.	AccessMaster Mast Assembly	8-7
8-2.	Mast Chains/Cables Routing Diagram	8-15
9-1.	Base Frame Outrgr. Socket Contactor Heads and Outrgr. Beam Contactor Plate	9-1
9-2.	Hydraulic Diagram (AC & DC Machines)	9-5

LIST OF TABLES

TABLE NO.	TITLE	PAGE NO.
1-1.	Minimum Safe Approach Distances (<i>to energized power lines</i>)	1-1
7-1.	Recommended Hydraulic Oils	7-2
7-2.	Lubrication Specifications	7-2
8-1.	Chain Stretch Tolerance	8-3
8-2.	Preventive Maintenance and Inspection Schedule	8-16
9-1.	A.C. Units Troubleshooting	9-2
9-2.	D.C. Units Troubleshooting	9-3

1-1. GENERAL

This section prescribes the proper and safe practices for major areas of machine usage which have been divided into three basic categories: Transporting, Pre-Operation and Operation. In order to promote proper usage of the machine, it is mandatory that a daily routine be established based on instruction given in this section. A maintenance program must also be established by a qualified person and must be followed to ensure that the machine is safe to operate.

The user/operator of the machine should not accept operating responsibility until this manual has been READ and UNDERSTOOD, and operating instructions of the machine under the supervision of an experienced and qualified operator, has been completed. If there is a question on application and/or operation, JLG Industries Product Safety and Reliability should be consulted.

⚠ WARNING

MODIFICATION OF THE MACHINE WITHOUT APPROVAL OF JLG INDUSTRIES, OR CERTIFICATION BY A NATIONALLY RECOGNIZED TESTING LAB TO BE IN CONFORMITY WITH APPLICABLE OSHA REGULATIONS, AND TO BE AT LEAST AS SAFE AS BEFORE MODIFICATION, IS PROHIBITED AND IS A VIOLATION OF OSHA RULES.

1-2. ELECTROCUTION HAZARD

Minimum safe approach distances (M.S.A.D.) to energized (exposed or insulated) power lines and parts.

⚠ DANGER

DO NOT maneuver machine or personnel to distance less than M.S.A.D (See Table 1-1.). ASSUME all electrical parts and wiring are ENERGIZED unless known otherwise.

THIS MACHINE DOES NOT PROVIDE PROTECTION FROM CONTACT WITH OR PROXIMITY TO AN ELECTRICALLY CHARGED CONDUCTOR. MAINTAIN A CLEARANCE OF AT LEAST 10 FEET (3 M) BETWEEN ANY PART OF THE MACHINE AND ANY ELECTRICAL LINE OR APPARATUS CARRYING UP TO 50,000 VOLTS. ONE FOOT (0.3 M) ADDITIONAL CLEARANCE IS REQUIRED FOR EVERY ADDITIONAL 30,000 VOLTS OR LESS. ALLOW FOR PLATFORM SWAY, ROCK OR SAG AND ELECTRICAL LINE SWAYING, (SEE FOLLOWING TABLE).

Table 1-1. Minimum Safe Approach Distance (to energized power lines or parts)	
VOLTAGE RANGE (PHASE TO PHASE)	MINIMUM SAFE DISTANCE - FEET [M]
0-300V	– Avoid Contact
Over 300V to 50KV	– 10 ft. [3 m]
Over 50KV to 200KV	– 15 ft. [4.6 m]
Over 200KV to 350KV	– 20 ft. [6 m]
Over 350KV to 500KV	– 25 ft. [7.6 m]
Over 500KV to 750KV	– 35 ft. [106 m]
Over 750KV to 1000KV	– 45 ft. [13.7 m]

1-3. TRANSPORTING

Before transporting the machine the user/operator must be familiar with the proper procedures for transporting the machine, as well as the weight and size of the machine.

The user/operator should be familiar with the surrounding work area and surface before transporting the machine. The work area must be a smooth, firm surface on which machine is capable of being leveled.

Note

Remember that the key to safe and proper usage is common sense and its careful application.

⚠ WARNING

FAILURE TO COMPLY WITH SAFETY PRECAUTIONS LISTED IN THIS SECTION AND ON MACHINE MAY RESULT IN MACHINE DAMAGE, PERSONNEL INJURY OR DEATH AND IS A SAFETY VIOLATION.

1-4. TRANSPORT SAFETY

- COMPLETELY EMPTY PLATFORM OF TOOLS AND DEBRIS BEFORE MOVING MACHINE.
- FULLY LOWER PLATFORM, REMOVE AND STOW OUTRIGGERS WHILE MACHINE IS BEING MOVED.
- NEVER ALLOW PERSONNEL IN PLATFORM WHILE MOVING MACHINE.

⚠ WARNING

FAILURE TO OBSERVE THE FOLLOWING TIPPING HAZARD INSTRUCTIONS COULD CAUSE THE UNIT

TO TIP OVER OR BE HARD TO CONTROL WHEN BEING MOVED, WHICH COULD RESULT IN SERIOUS INJURY OR DEATH DUE TO BEING PINNED OR CRUSHED BY THE UNIT.

- ON A LEVEL SURFACE, ALWAYS TRAVEL WITH THE PLATFORM END LEADING THE WAY.
- WATCH FOR OBSTRUCTIONS AROUND MACHINE AND OVERHEAD WHEN MOVING.
- CHECK TRAVEL PATH FOR PERSONS, HOLES, BUMPS, DROP-OFFS, OBSTRUCTIONS, DEBRIS, AND COVERINGS WHICH MAY CONCEAL HOLES AND OTHER HAZARDS, AS TIPPING COULD OCCUR. (SEE FIGURE 1-1.)
- BEFORE MOVING MACHINE ON FLOORS, TRUCKS AND OTHER SURFACES, CHECK ALLOWABLE CAPACITY OF SURFACES.
- DO NOT MOVE ON SOFT OR UNEVEN SURFACES, AS TIPPING WILL OCCUR.
- TWO PEOPLE ARE REQUIRED ON SLOPES UP TO 5 DEGREES. A FORKLIFT MUST BE USED WHEN MOVING UNITS ON SLOPES GREATER THAN 5 DEGREES. (SEE FIGURE 1-2.)
- ALWAYS TRAVEL UP OR DOWN A SLOPE WITH THE PLATFORM END OF THE MACHINE POSITIONED TOWARDS THE LOW SIDE OF THE SLOPE. THE OPERATOR AND ASSISTANT MUST WALK BESIDE UNIT AND GUIDE THE MACHINE WITH THE PLATFORM HANDRAILS.
- NEVER POSITION THE UNIT SIDWAYS ON A SLOPE.
- KEEP CLEAR FROM BEHIND AND IN FRONT OF UNIT. (SEE FIGURE 1-1. & 1-2.)
- USE CAUTION AND CHECK CLEARANCES WHEN MOVING MACHINE IN RESTRICTED OR CLOSE QUARTERS.
- ALWAYS USE AN ASSISTANT WHEN MOVING MACHINE IN AREAS WHERE VISION IS OBSTRUCTED.
- KEEP NON-OPERATING PERSONNEL AT LEAST 6 FEET (1.8 M) AWAY FROM MACHINE DURING TRANSPORTING OPERATIONS.

CORRECT! way to push on a **SMOOTH/FIRM** surface.

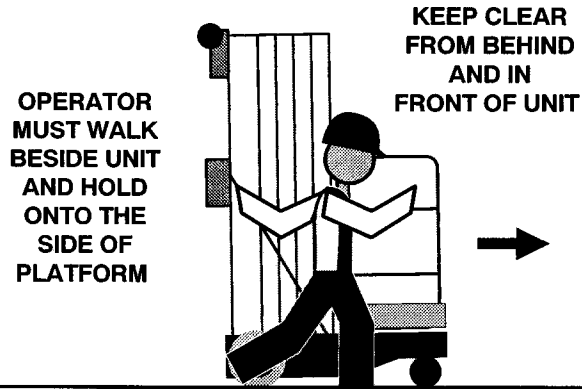

INCORRECT!

WARNING

WITH OPERATOR PUSHING MACHINE FROM PLATFORM END, MACHINE COULD TIP IF AN OBSTRUCTION ON SURFACE IS ENCOUNTERED.

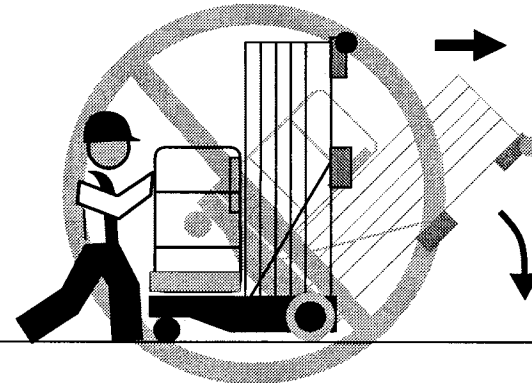

Figure 1-1. Pushing Machine on a SMOOTH, FIRM surface.

1-5. PRE-OPERATIONAL SAFETY

- READ YOUR MANUAL. UNDERSTAND WHAT YOU'VE READ - THEN BEGIN OPERATIONS.
- ALLOW ONLY THOSE AUTHORIZED AND QUALIFIED PERSONNEL TO OPERATE MACHINE WHO HAVE DEMONSTRATED THAT THEY UNDERSTAND SAFE AND PROPER OPERATION AND MAINTENANCE OF THE UNIT.
- AN OPERATOR MUST NOT ACCEPT OPERATING RESPONSIBILITIES UNTIL ADEQUATE TRAINING HAS BEEN GIVEN BY COMPETENT AND AUTHORIZED PERSONS.

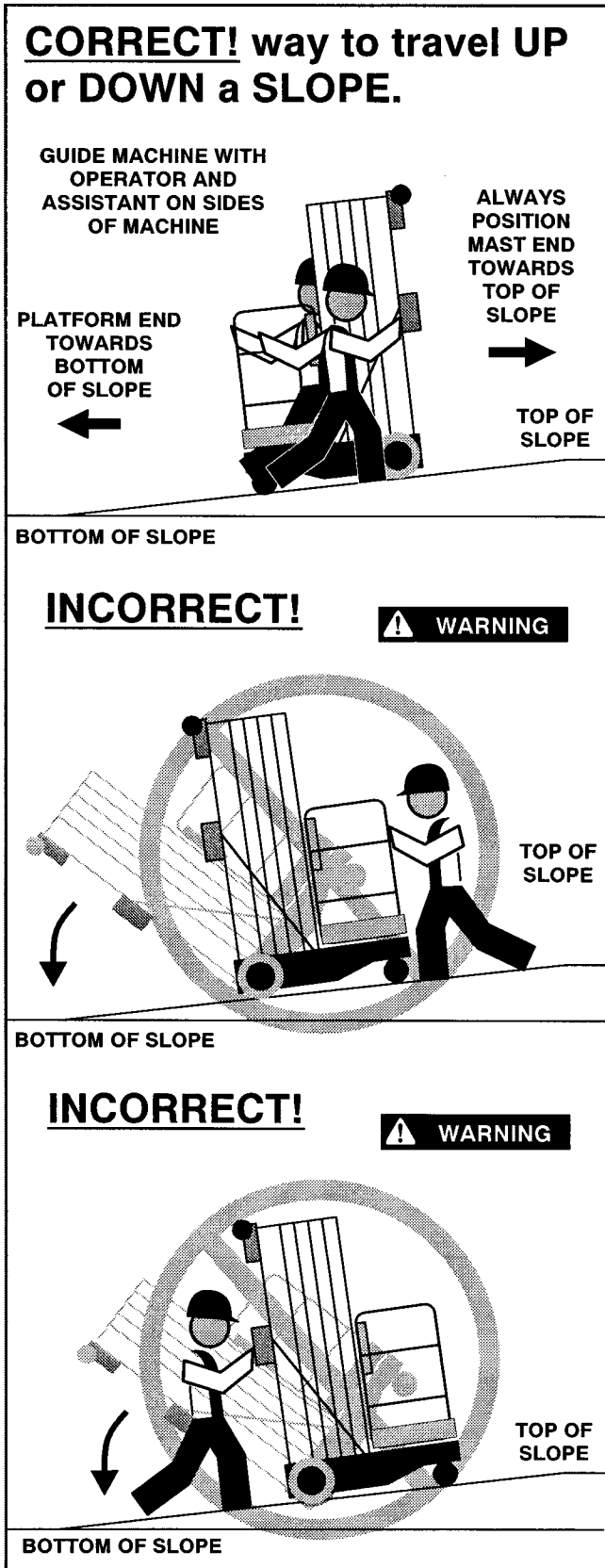

Figure 1-2. Pushing Machine on a SLOPE.

- BEFORE OPERATION CHECK WORK AREA FOR OVERHEAD ELECTRIC LINES. (SEE ELECTROCUTION HAZARD, SECTION 1-2.)
- ALSO BEFORE OPERATION CHECK WORK AREA FOR MACHINE TRAFFIC SUCH AS FORKLIFTS, CRANES, AND OTHER CONSTRUCTION EQUIPMENT.
- SET-UP MACHINE FOR OPERATION ONLY ON A SMOOTH, FIRM SURFACE ON WHICH THE MACHINE IS CAPABLE OF BEING LEVELLED.
- ENSURE THAT OPERATORS OF OTHER OVERHEAD AND FLOOR LEVEL MACHINES ARE AWARE OF THE AERIAL PLATFORMS PRESENCE. DISCONNECT POWER TO OVERHEAD CRANES. BARRICADE FLOOR AREA IF NECESSARY.
- PRECAUTIONS TO AVOID ALL KNOWN HAZARDS IN THE WORK AREA MUST BE TAKEN BY THE OPERATOR AND HIS SUPERVISOR BEFORE STARTING THE WORK.
- DO NOT OPERATE THIS MACHINE UNLESS IT HAS BEEN SERVICED AND MAINTAINED ACCORDING TO THE MANUFACTURERS SPECIFICATIONS AND SCHEDULE.
- ENSURE DAILY INSPECTION AND FUNCTION CHECK IS PERFORMED PRIOR TO PLACING MACHINE INTO OPERATION. HAVE AUTHORIZED PERSONNEL TAKE ANY NECESSARY CORRECTIVE ACTION BEFORE PLACING MACHINE INTO OPERATION.
- NEVER DISABLE OR MODIFY ANY SAFETY DEVICE. ANY MODIFICATION OF THE MACHINE IS A SAFETY VIOLATION AND IS A VIOLATION OF OSHA AND ANSI RULES.
- DO NOT OPERATE MACHINE WHEN EXPOSED TO HIGH WIND, RAIN OR SNOW.
- NEVER OPERATE OR RAISE PLATFORM WHEN MACHINE IS ON A TRUCK OR OTHER VEHICLE.
- APPROVED HEAD GEAR (I.E. HARD HAT, ETC.) MUST BE WORN WHEN REQUIRED BY ALL OPERATING AND GROUND PERSONNEL.
- READ AND OBEY ALL DANGER, WARNINGS, CAUTIONS AND OPERATING INSTRUCTIONS ON MACHINE AND IN THIS MANUAL.
- BE FAMILIAR WITH LOCATION AND OPERATION OF GROUND STATION AND EMERGENCY CONTROLS.

1-6. OPERATING SAFETY

- READ YOUR MANUAL, UNDERSTAND WHAT YOU'VE READ - THEN BEGIN OPERATIONS.
- DO NOT OPERATE ANY MACHINE ON WHICH DANGER, WARNING, CAUTION OR INSTRUCTION PLACARDS OR DECALS ARE MISSING OR ILLEGIBLE.
- NEVER EXCEED MANUFACTURERS RATED PLATFORM CAPACITY - REFER TO CAPACITY DECAL ON MACHINE.
- OPERATE AC UNITS WITH AN EXTENSION CORD WIRE RATED AT A MINIMUM OF 15 AMPS.
- THE MACHINE IS EQUIPPED WITH AN OUTRIGGER INTERLOCK SYSTEM THAT WILL NOT ALLOW THE PLATFORM TO BE RAISED UNLESS ALL FOUR OUTRIGGERS ARE PROPERLY INSTALLED AND MACHINE IS LEVELED.
- DO NOT ENTER PLATFORM UNTIL ALL LEVELING JACKS HAVE BEEN PROPERLY ADJUSTED AND THE UNIT'S BASE FRAME IS LEVEL ACCORDING TO THE BUBBLE LEVELING INDICATOR ON BASE FRAME, AND ALL WHEELS ARE COMPLETELY OFF THE GROUND.
- DO NOT OPERATE MACHINE ON SOFT FOOTING THAT WILL ALLOW LEVELING JACKS TO SETTLE INTO OR BREAK THROUGH SURFACE.
- NEVER OPERATE A MALFUNCTIONING MACHINE. IF A MALFUNCTION OCCURS, SHUT DOWN THE MACHINE, RED TAG IT, AND NOTIFY PROPER AUTHORITIES.
- ALL PERSONNEL MUST STAND CLEAR WHEN PLATFORM IS BEING RAISED OR LOWERED. BE SURE TO WATCH FOR OVERHEAD AND OTHER OBSTRUCTIONS.
- CHECK CLEARANCES ABOVE, ON SIDES AND BOTTOM OF PLATFORM WHEN RAISING AND LOWERING PLATFORM.
- NEVER USE THE MAST TO GAIN ACCESS TO OR LEAVE PLATFORM.
- DO NOT ATTACH OVERHANGING LOADS TO THE PLATFORM OR INCREASE THE PLATFORM SIZE WITH UNAUTHORIZED DECK EXTENSIONS OR ATTACHMENTS.
- DO NOT TIE OFF MACHINE TO ANY ADJACENT STRUCTURE. NEVER ATTACH WIRE, CABLE OR ANY SIMILAR ITEMS TO PLATFORM.
- TO AVOID FALLING - USE EXTREME CAUTION WHEN ENTERING OR LEAVING PLATFORM ABOVE GROUND. ENTER OR EXIT THRU GATE ONLY. PLATFORM MUST BE WITHIN 1 FOOT (0.3 M) OF ADJACENT - SAFE AND SECURE - STRUCTURE. ALLOW FOR ANY VERTICAL MOVEMENT OF PLATFORM (UP OR DOWN) WHEN ENTERING OR LEAVING PLATFORM.
- NO HORSEPLAY IS PERMITTED IN PLATFORM.
- DO NOT ALLOW PERSONNEL TO TAMPER WITH, SERVICE, OR OPERATE THIS MACHINE FROM THE GROUND WITH PERSONNEL IN PLATFORM EXCEPT IN AN EMERGENCY.
- DURING OPERATION KEEP ALL BODY PARTS INSIDE PLATFORM RAILINGS.
- NEVER POSITION LADDERS, STEPS, OR SIMILAR ITEMS ON UNIT TO PROVIDE ADDITIONAL REACH FOR ANY PURPOSE.
- WHEN WORKING FROM PLATFORM BOTH FEET MUST BE FIRMLY POSITIONED ON DECK.
- DO NOT EXTEND REACH LIMITS OF THIS MACHINE WITH ADDITIONAL EQUIPMENT SUCH AS PLANKS, BOXES, ETC.
- DO NOT USE LADDERS ON OR AGAINST MACHINE. DO NOT PERFORM WORK THAT WILL SUBJECT UNIT TO A HORIZONTAL FORCE OR CREATE A ROCKING MOTION OF THE PLATFORM.
- DO NOT OPERATE WITHOUT SLIDE BAR GATE (OR SWING GATE ON PLASTIC BASKET MODELS) IN PLACE AND PROPERLY CLOSED. THIS IS A SAFETY VIOLATION.
- ALWAYS ENSURE THAT POWER TOOLS ARE PROPERLY STOWED AND NEVER LEFT HANGING BY THEIR CORD FROM THE PLATFORM WORK AREA.
- AVOID ACCUMULATION OF DEBRIS ON PLATFORM WORK AREA. KEEP MUD, OIL, GREASE AND OTHER SLIPPERY SUBSTANCES FROM FOOTWEAR AND PLATFORM DECK.

2-1. GENERAL

This section provides the necessary information needed by those personnel that are responsible to place the machine in operation readiness, and lists checks that are performed prior to use of the machine. It is important that the information contained in this section be read and understood before any attempt is made to operate the machine. Ensure that all the necessary inspections have been completed successfully before placing the machine into service. These procedures will aid in obtaining maximum service life and safe operation.

⚠ IMPORTANT

SINCE THE MACHINE MANUFACTURER HAS NO DIRECT CONTROL OVER THE FIELD INSPECTION AND MAINTENANCE, THIS IS THE RESPONSIBILITY OF THE OWNER/OPERATOR.

2-2. PREPARATION FOR USE

Before a new machine is put into operation it must be carefully inspected for any evidence of damage resulting from shipment and inspected periodically thereafter, as outlined in Section 2-3, Delivery and Periodic Inspection. The unit should be thoroughly checked for hydraulic leaks during initial start-up and run. A check of all components should be made to assure their security.

All preparation necessary to place the machine in operation readiness status are the responsibility of management personnel. Preparation requires good common sense, (i.e. lift works smoothly) coupled with a series of visual inspections. The mandatory requirements are given in Section 2-4, Daily Walk Around Inspection.

It should be assured that the items appearing in the Delivery and Frequent Inspection and Functional Check are complied with prior to putting the machine into service.

2-3. DELIVERY AND FREQUENT INSPECTION

The following check list provides a systematic inspection to assist in detecting defective, damaged, or improperly installed parts. The check list denotes the items to be inspected and conditions to examine. Frequent inspection shall be performed every three (3) months or more often when required by environment, severity, and frequency of usage.

• **Handrail Assemblies**

Properly installed; no loose or missing parts; no visible damage.

• **Platform Assembly**

No visible damage; free of dirt and debris. Platform gate functions properly on machines so equipped.

• **Mast**

No visible damage, abrasions and/or distortions; no binding; mast sections free of dirt or other foreign material. Sequencing cables properly secured; no visible damage; proper cable tension.

• **Mast Chains & Cables**

No visible damage; proper chain/cable tension; evidence of proper lubrication. Chain/cable sheaves, sheave pins and rollers properly secured; no visible damage.

• **Control/(Power) Cable(s) for Platform**

No visible damage; cable properly tensioned and seated in control cable sheaves; control cable sheaves not damaged and rotating freely.

• **Lift Cylinder**

No rust, nicks, scratches or foreign material on piston rod. No leakage. Evidence of proper lubrication.

• **Frame**

No visible damage; loose or missing hardware (top and underside); outrigger sockets not bent or damaged; outrigger beam locking pins properly secured; outrigger interlock LED's properly secured and undamaged.

• **Wheels and Casters**

Free rolling; no loose or missing parts; no visible damage.

• **Hydraulic Oil Supply**

Check the hydraulic oil level at the hydraulic fluid reservoir through the access hole on the side of the ground control panel. Unscrew the breather cap and check the fluid level indicator on the dipstick.

If fluid level is low, see Section 7 - Specifications; Sub-Section 7-5. "Lubrication"; Table 7-1. "Recommended Hydraulic Oils" for use in machine.

• **Machine Controls - (Platform and Ground)**

Switches operable; no visible damage; placards secure and legible.

• **Batteries - (DC Models)**

Proper electrolyte level; cable connections tight; no visible damage; no corrosion at battery cable connections.

• **Power Cord - (AC Models)**

No visible damage; connector and cable properly secured.

• **Electric Motor/Hydraulic Pump and Valve**

No leakage; unit secure.

• **Placards**

No visible damage; placards secure and legible.

2-4. DAILY WALK-AROUND INSPECTION

It is the user/operator's responsibility to inspect the machine before the start of each workday. It is recommended that each user/operator inspect the machine before operation, even if the machine has already been put into service under another user/operator. This Daily Walk-Around Inspection is the preferred method of inspection.

• **GENERAL**

Begin the "Walk-Around Inspection" at item 1 listed following. Continue around machine check-

ing each item in sequence for the conditions listed in the "Walk-Around Inspection Check list".

⚠ WARNING

TO AVOID INJURY DO NOT OPERATE MACHINE UNTIL ALL MALFUNCTIONS HAVE BEEN CORRECTED. USE OF A MALFUNCTIONING MACHINE IS A SAFETY VIOLATION.

TO AVOID POSSIBLE INJURY, BE SURE MACHINE POWER IS "OFF" DURING "WALK-AROUND INSPECTION".

Note

Do not overlook visual inspection of chassis underside. Checking this area often results in discovery of conditions which could cause extensive machine damage.

1. **Wheels and Casters** - Properly secured, wheels and casters turn freely and are properly lubricated. Check for any visible damage.
2. **Base Frame** - No visible damage; components properly secured, no loose wires dangling below base; bubble level in place and functioning properly.
3. **Tilt Back Outrigger - (AM30 & 36 Models Only)** Properly secured; no visible damage; no parts missing i.e.. safety pins, gas spring cylinders, caster wheels, etc.
4. **Battery/Battery Charger Installation - (DC Machines)** Proper battery electrolyte level, cables secure, no damage or corrosion. Battery box pivots freely when machine is tilted for transporting *(AM30 & 36 Models Only)*.
5. **Outrigger Interlock Indicator LED's** - Properly secured, no visible damage.
6. **Outrigger Sockets** - Properly secured to frame, no visible damage *(cracks, distortion, etc.)*. Outrigger lock/release pins in place and secure, no visible damage. Outrigger interlock contacts *(inside outrigger sockets)* secure and clean.
7. **Outrigger Beams** - No visible damage *(cracks, distortion, etc.)*, outrigger interlock contacts properly installed and clean. Leveling jacks secure, lubricated and functioning properly.
8. **Motor/Pump/Reservoir Unit** - All properly secured, no visible damage, no evidence of hydraulic leaks. Check that hydraulic reservoir fluid level is to full mark on dipstick, breather cap is on tight.

- 9. **Control Valve/Manual Release Valve** - Properly secured, no loose or missing parts, no visible damage.
- 10. **Ground Controls** - Key switch operable, no visible damage; placards secure and legible; emergency stop switch, no visible damage and properly set for operation.
- 11. **Mast Installation** - Mast sections properly secured, no visible damage to mast sections, no

loose or missing parts, slide pads properly secured. Mast chains and cables properly secured and lubricated. Sequencing cables properly secured and undamaged.

- 12. **Handrail Installation** - All railings securely attached, no visible damage, no missing parts; sliding entry bar in proper working order. Platform gate working properly, no visible sign of damage (if so equipped).

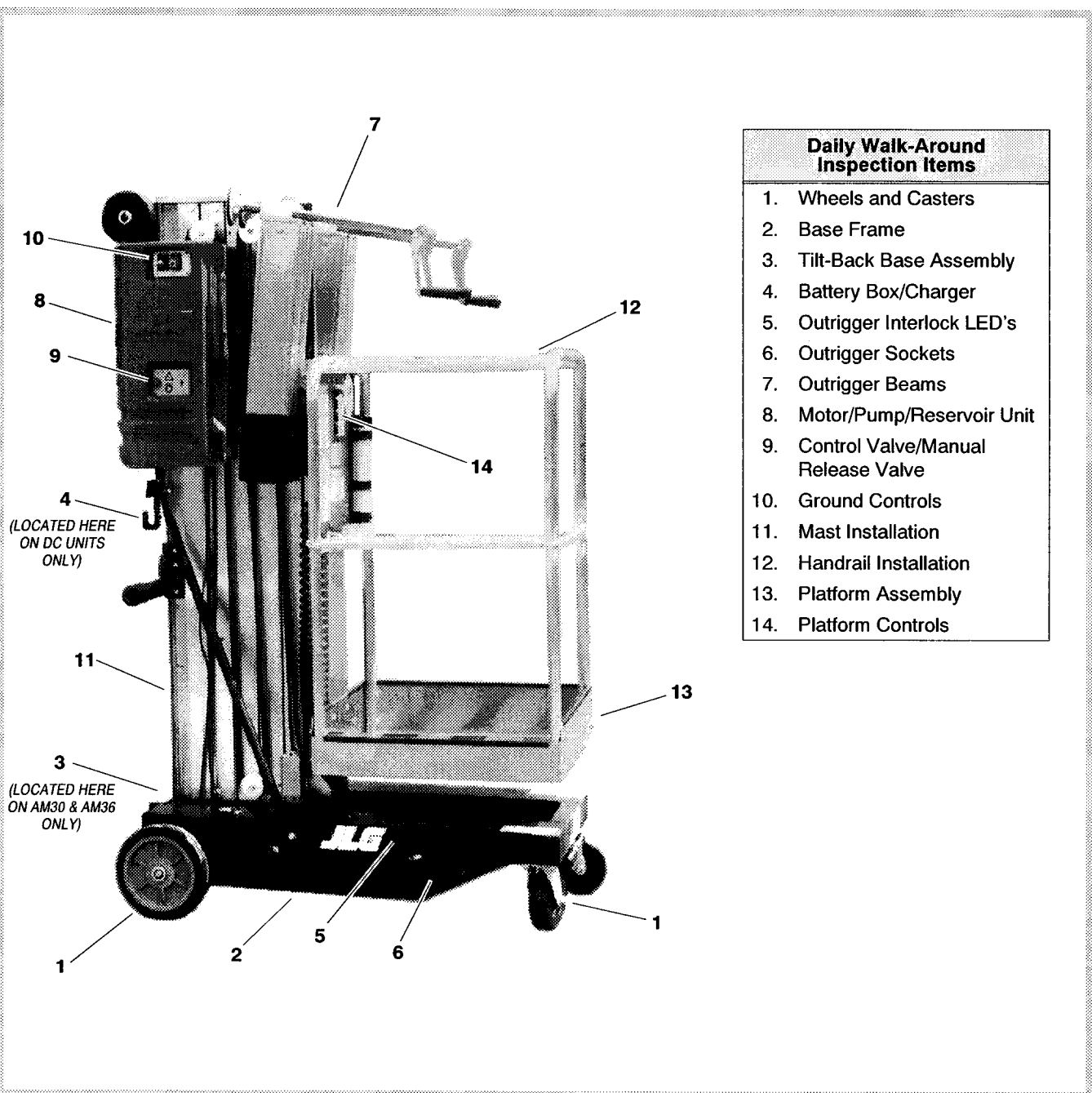

Daily Walk-Around Inspection Items	
1.	Wheels and Casters
2.	Base Frame
3.	Tilt-Back Base Assembly
4.	Battery Box/Charger
5.	Outrigger Interlock LED's
6.	Outrigger Sockets
7.	Outrigger Beams
8.	Motor/Pump/Reservoir Unit
9.	Control Valve/Manual Release Valve
10.	Ground Controls
11.	Mast Installation
12.	Handrail Installation
13.	Platform Assembly
14.	Platform Controls

Figure 2-1. Daily Walk-Around Inspection.

13. Platform Assembly - Secure to mast; no loose or missing parts, no visible damage. Control and power cables, no visible damage; cables properly tensioned and seated in control cable sheaves; control cable sheaves not damaged and rotate freely.

14. Platform Controls - Up/Down and Function Enable buttons properly secured, no loose or missing parts, no visible damage. Placards secure and legible, emergency shut-off button set for operation. Control markings legible; Operators manual enclosed in manual storage tube.

In addition to the Daily Walk-Around Inspection, be sure to include the following as part of the daily inspection:

• Batteries Charged (DC Models)

Start each day with fully charged batteries. (See Section 2-7. "Battery Charging")

• Overall Cleanliness

Keep oil, grease, water, etc. wiped from standing surfaces and hand holds.

• Placards

Keep all information and operating placards clean and unobstructed. Cover areas where placards are present when using the machine for spraying paint or any material which could cover these surfaces and reduce legibility.

• Operators, Safety, and Maintenance Manual

Ensure a copy of this manual is enclosed in the manual storage box.

• Lubrication

For those parts pointed out in the Walk-Around Inspection requiring lubrication, refer to the Lubrication Chart, Figure 7-2., Section 7, for specific time interval requirements.

2-5. DAILY FUNCTIONAL CHECK

⚠ WARNING

TO AVOID INJURY DO NOT OPERATE A MACHINE UNTIL ALL MALFUNCTIONS HAVE BEEN CORRECTED. USE OF A MALFUNCTIONING MACHINE IS A SAFETY VIOLATION.

Once the walk-around inspection is complete, a functional check of all systems should be performed in an area free of overhead and ground level obstructions. Perform a functional check in accordance with the following procedures:

1. Set-up machine for operation, according to instructions in Section 4-3, "Machine Set-Up & Operation", i.e.. install outriggers, level machine, make sure all wheels are off ground, etc.
2. Enter platform, raise and lower platform two (2) to three (3) feet several times. Check for smooth elevation and lowering of platform.
3. With platform completely lowered, check hydraulic oil level in reservoir at ground control station. Oil level should show full on the dipstick. If necessary, add hydraulic fluid to proper level. **NEVER USE HYDRAULIC BRAKE FLUID, refer to the Lubrication Chart, Figure 7-2, for specific requirements.**

2-6. TORQUE REQUIREMENTS

The Torque Chart, Figure 7-1, consists of standard torque values based on bolt diameter and grade, it also specifies dry and wet torque values in accordance with recommended shop practices. This chart is provided as an aid to the user/operator in the event he/she notices a condition that requires prompt attention during the walk-around inspection or during operation until the proper service personnel can be notified. Utilizing this Torque Chart in conjunction with the preventive maintenance section in Section 8, will enhance the safety, reliability and performance of the machine.

2-7. BATTERY CHARGING (DC Machines)

The battery-operated DC Models are equipped with either a 115 Volt AC - 50/60 Hz input or 230 Volt AC - 50/60 Hz input battery charger. Both battery chargers have an output of 12 Volts, and are equipped with a 12-hour timer.

⚠ CAUTION

WHEN ADDING DISTILLED WATER TO THE BATTERIES, A NON-METALLIC CONTAINER AND/OR FUNNEL MUST BE USED.

NO OPEN FLAMES OR SMOKING WHEN CHARGING BATTERIES.

CHARGE BATTERIES ONLY IN A WELL VENTILATED AREA.

ENSURE THAT BATTERY ACID DOES NOT COME INTO CONTACT WITH SKIN OR CLOTHING.

At the end of the work day, the batteries should be charged for the next days work. Check the electrolyte level of the batteries, and adjust accordingly (*cells should be completely covered but DO NOT OVERFILL, allow for electrolyte expansion or battery will overflow while charging*). Add only distilled water to batteries. Connect the battery charger to a properly grounded receptacle using a suitable extension cord. Set the battery charger timer switch for the desired charging time. A fully charged battery will have a specific gravity of between 1.260 - 1.275 on a hydrometer.

If necessary, the machine may be operated while the battery is charging.

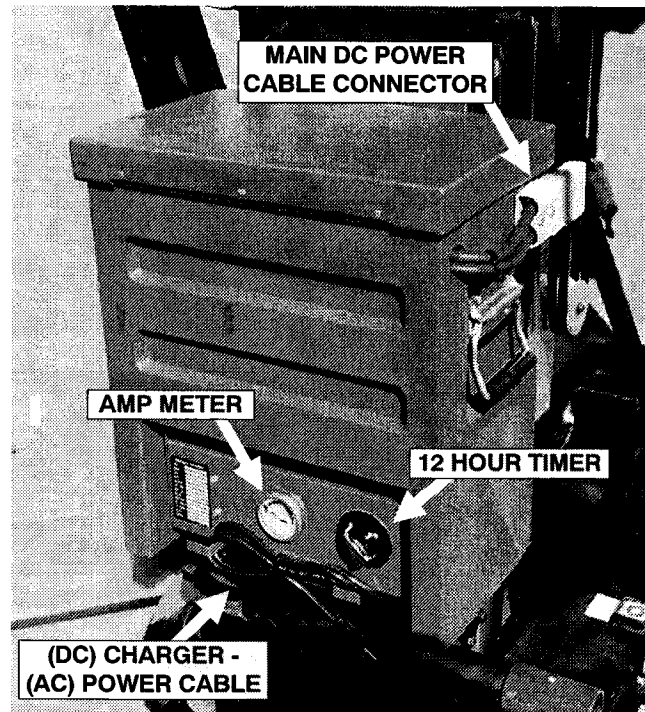

**Figure 2-2. Battery Box & Charger Assembly.
(DC Models only)**

3-1. GENERAL

⚠ IMPORTANT

SINCE THE MANUFACTURER HAS NO DIRECT CONTROL OVER MACHINE APPLICATION AND OPERATION, CONFORMANCE WITH GOOD SAFETY PRACTICES IN THESE AREAS IS THE RESPONSIBILITY OF THE USER AND HIS OPERATING PERSONNEL.

This section provides the necessary information needed to understand control functions. Included in this section are the operating characteristics and limitations, and functions and purposes of controls and indicators. It is important that the user/operator read and understand the proper procedures before operating the machine. These procedures will aid in obtaining optimum service life and safe operation.

3-2. PERSONNEL TRAINING

The aerial lift is a personnel handling device; therefore, it is essential that it be operated and maintained only by authorized personnel who have demonstrated that they understand the proper use and maintenance of the machine. It is important that all personnel who are assigned to and responsible for the operation and maintenance of the machine undergo a thorough training program and check out period in order to become familiar with the characteristics prior to operating the machine.

In addition, personnel operating the machine should be familiar with ANSI standard A92.3-1990, Responsibilities. This standard contains sections outlining the responsibilities of the owners, users, operators, lessors and lessees concerning safety, training, inspection, maintenance, application and operation.

Persons under the influence of drugs or alcohol or who are subject to seizures, dizziness or loss of physical control must not be permitted to operate the machine.

• **Operator Training**

Operator training must include instruction in the following:

1. Use and limitations of the platform controls, ground controls and emergency controls.
2. Knowledge and understanding of this manual and of the control markings, instructions and warnings on the machine itself.

3. Knowledge and understanding of all safety work rules of the employer and Federal, State and Local Statutes, including training in the recognition and avoidance of potential hazards in the work place; with particular attention to the work to be performed.
4. Proper use of all required personnel safety equipment.
5. Sufficient knowledge of the mechanical operation of the machine to recognize a malfunction or potential malfunction.
6. The safest means to operate near overhead obstructions, other moving equipment, obstacles, depressions, holes, drop-offs, etc. on the supporting surface.
7. Means to avoid the hazards of unprotected electrical conductors.
8. Any other requirements of a specific job or machine application.

• **Training Supervision**

Training must be done under the supervision of a qualified operator or supervisor in an open area free of obstructions until the trainee has developed the ability to safely control an aerial lift in congested work locations.

• **Operator Responsibility**

The operator must be instructed that he has the responsibility and authority to shut down the machine in case of a malfunction or other unsafe condition of either the machine or the job site and to request further information from his supervisor or JLG Distributor before proceeding.

Note

Manufacturer or Distributor will provide qualified persons for training assistance with first unit(s) delivered and thereafter as requested by user or his personnel.

3-3. OPERATING CHARACTERISTICS AND LIMITATIONS

• General

- A thorough knowledge of the operating characteristics and limitations of the machine is always the first requirement for any user, regardless of user's experience with similar types of equipment.

• Placards

Important points to remember during operation are provided at the control stations by DANGER, WARNING, CAUTION, IMPORTANT and INSTRUCTION placards. This information is placed at various locations for the express purpose of alerting personnel of potential hazards constituted by the operating characteristics and load limitations of the machine. See foreword for definitions of the above placards.

• Capacities

Raising the platform above the stowed position is based on the following criteria:

- The machine is positioned on a smooth, firm surface on which the machine is capable of being leveled.
- The load is within manufacturer's rated capacity.
- All machine systems are functioning properly.
- The machine is leveled and outriggers are properly installed and locked in place as indicated by the outrigger interlock LED's on the base frame.

• Stability

This machine, as originally manufactured by JLG and operated within its rated capacity on a smooth, firm and level supporting surface, provides a stable aerial platform for all platform positions.

3-4. CONTROLS AND INDICATORS

• Ground Control Station

(See Figure 3-1.)

Note

When the machine is shut down for overnight parking or battery charging, be sure the POWER ON/OFF KEY SWITCH is positioned to OFF to prevent draining the batteries.

1. POWER ON/OFF Key Switch

A key operated power on/off switch located on the ground control station panel controls power to all functions on the unit. The machine will not operate without the key inserted and turned to the ON position. When left unattended removing key will prevent unauthorized machine use.

2. EMERGENCY STOP Button

An emergency stop (RED button) is mounted on both the ground control station and the platform control panel. When the button is depressed, all machine functions will stop. To re-activate power to the machine, turn emergency stop button clockwise until button is reset.

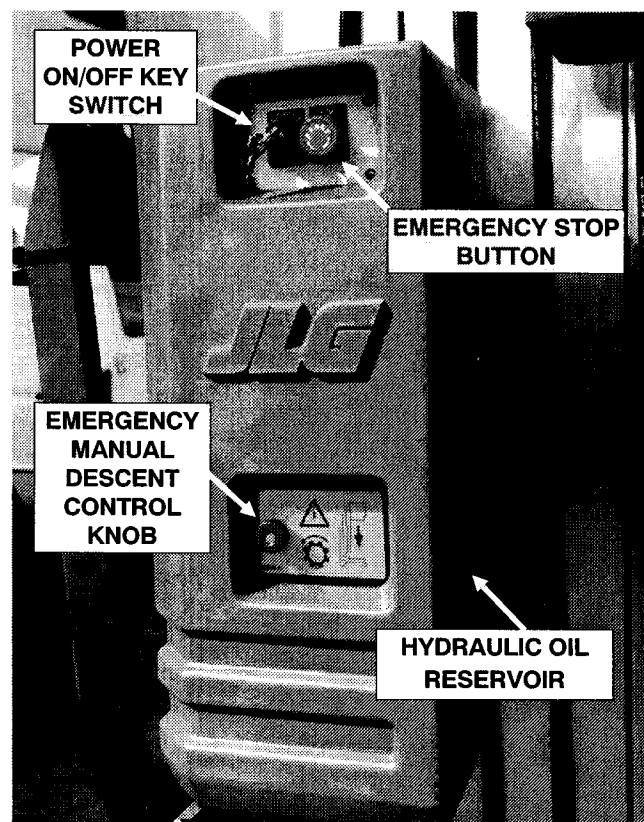

Figure 3-1. Ground Control Station.

3. EMERGENCY/MANUAL DESCENT Knob

This (RED knurled) knob, located on the electric/hydraulic pump-motor unit on the lower half of the ground control station panel provides for lowering of the platform in the event of an emergency or power failure. Refer to Section 6 for Emergency Descent operating procedures.

4. HYDRAULIC RESERVOIR/CIRCUIT BREAKER / FUSE

(located inside ground control station housing)

The hydraulic reservoir is housed inside the ground control station, the hydraulic oil level can be checked through an access hole in the side of the cover by unscrewing the reservoir cap and checking the dipstick.

Note

Always check hydraulic oil when platform is completely lowered position.

Also located inside the housing, on AM-AC Models, is a 20 Amp circuit breaker which is provided to restore interrupted power to the platform controls.

On AM-DC Models, a 5 Amp fuse is provided to interrupt power to the platform controls in the event of an electrical overload.

• **Platform Control Station**

(See Figure 3-2.)

1. EMERGENCY STOP/SHUT-OFF Button.

An EMERGENCY STOP (RED) button is provided in order to turn machine power on and off in the platform and also to turn off machine power in the event of an emergency. Power is on when the switch is in the reset position (turned completely clockwise - out). Power is off and all machine functions will stop, when button is depressed.

2. FUNCTION ENABLE Button.

This (GREEN) button must be depressed simultaneously with either the UP or DOWN platform function buttons in order to operate the platform.

3. Platform UP Button.

When depressed simultaneously with ENABLE button raises the platform to a higher level.

4. Platform DOWN Button.

When depressed simultaneously with ENABLE button lowers the platform to a lower level.

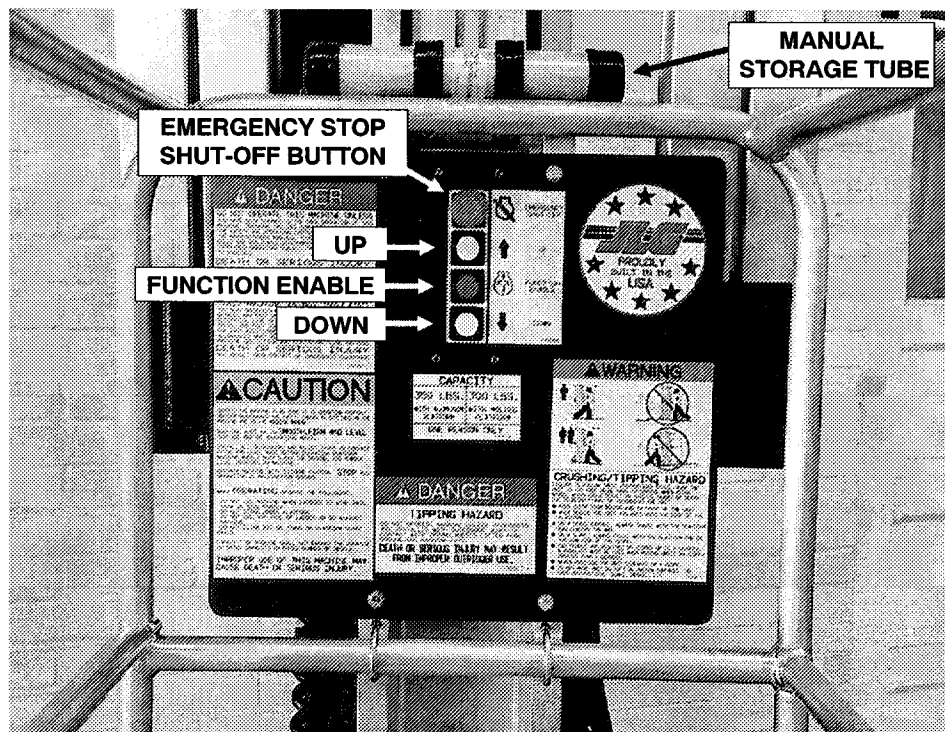

Figure 3-2. Platform Control Station.

4-1. MACHINE DESCRIPTION

The AccessMaster® model line of machines are a manually propelled machine, with an aerial work platform mounted to an elevating aluminum mast mechanism. The mast is raised and lowered by a hydraulic cylinder extending between mast section-1 and -2, the remaining mast sections are proportionally extended and retracted using steel chains and cables. Hydraulic pressure is supplied to the lift cylinder by an electrically powered hydraulic pump. All AM models feature a steel base frame with aluminum outriggers configured in an “X” pattern. The platform may be raised only when lift is positioned on smooth, firm surface on which the machine is capable of being leveled. The personnel lift’s intended purpose is to provide personnel (with their tools and supplies) access to areas above ground level.

The JLG personnel lift has a primary operator control station in the platform. From this control station the operator can raise and lower the platform. A ground control station is also provided. This station contains a keyed power on/off switch, an emergency stop button and an emergency/manual decent valve which enables the platform to be lowered to the ground in an emergency, if the operator in the platform is unable to do so, or if a power failure should occur.

Instructions and warnings are posted adjacent to both operator control stations and at other places on the machine. It is extremely important that the user/operator know what instructions and warnings are placed on the machine and in the manual. And that these instructions and warning be reviewed periodically.

The JLG personnel lift is designed to provide efficient and safe operation when maintained and operated in accordance with instructions and warnings on the machine, in the Operating, Safety and Maintenance Manual and all jobsite and government rules and regulations. As with any type of machinery, the operator is very important to efficient and safe operation.

It is absolutely necessary that the JLG lift be regularly maintained in accordance with this manual. Any evidence of lack of maintenance, malfunction, excessive wear, damage or modification to the machine must be reported immediately to the machine owner, the jobsite supervisor or safety manager and that the machine be taken out of service until all discrepancies are corrected.

The JLG personnel lift is not intended to be used to lift material other than supplies which personnel in the platform require to do their job. Supplies or tools which extend outside the platform are prohibited except for JLG approved receptacles. The personnel lift must not be used as a forklift, crane, or support for overhead structure.

The total platform capacity of models AM19-AC, AM19-DC, AM24-AC, AM24-DC, AM30-AC, AM30-DC, is 350 lb. (159 kg), and the capacity of models AM36-AC and AM36-DC is 300 lb. (136 kg), uniformly distributed in the center of the platform. This means that the total combined weight of personnel, tools and supplies loaded into the platform must not exceed the above figures.

4-2. GENERAL

This section provides the necessary information needed to operate the machine. Included in this section are the procedures for set-up, starting, stopping, raising, lowering, platform loading and transporting. It is important that the user read and understand the proper procedures before operating the machine. Although some of the more important operating safety precautions will be listed in the following paragraph sections, it is extremely important all safety precautions in Section 1 - Safety Precautions be read and understood before operating machine. If a “Daily Walk-Around Inspection”, (see Section 2-4.) has not been performed, do so before starting set-up and operation. The operator must also be familiar with all machine controls as described in Section 3 - User/Operator Responsibilities and Machine Controls.

4-3. MACHINE SET-UP AND OPERATION

The following sequence of set-up procedures must be followed to safely operate this machine.

1. Position machine in work area. Work area must be a smooth, firm surface on which machine is capable of being leveled.

Note

If AC powered machine, plug machine into appropriate grounded receptacle. If DC powered machine be sure battery box assembly is installed and plugged into machine DC receptacle.

2. Set Power On/Off Key Switch to the ON position at the ground control station.

Note

Check that both Emergency Stop Switches, one on platform control station and one on ground control station are in reset position for operation. Also check that Emergency/Manual Decent Control Knob valve is closed (on Ground Control Station).

3. Install outriggers, see steps following.

• Outrigger Installation

(See Figure 4-1.)

1. Start on either side of machine and remove an outrigger beam from the stowage sockets on either side of mast behind platform.
2. Insert outrigger beam into an outrigger socket on base frame with outrigger interlock contacts on bottom (i.e. with jackscrew **foot pad down** and **jack handle up**). Insert each outrigger beam in socket until locking pin snaps into outrigger beam detent. Do this for both sides of machine.

! IMPORTANT

AS A SAFETY PRECAUTION, OUTRIGGER BEAMS ARE DESIGNED TO BE MODEL SPECIFIC. THIS DESIGN PREVENTS THE SHORTER AM-19 & AM-24 OUTRIGGER BEAMS FROM BEING USED ON THE AM-30 & AM-36 MODELS WHICH REQUIRE A LONGER OUTRIGGER FOR GREATER STABILITY.

3. With all outriggers inserted and locked in place, crank each outrigger leveling jack down the minimum amount necessary for the base wheels to clear the floor. The red outrigger interlock LED's (near each outrig-

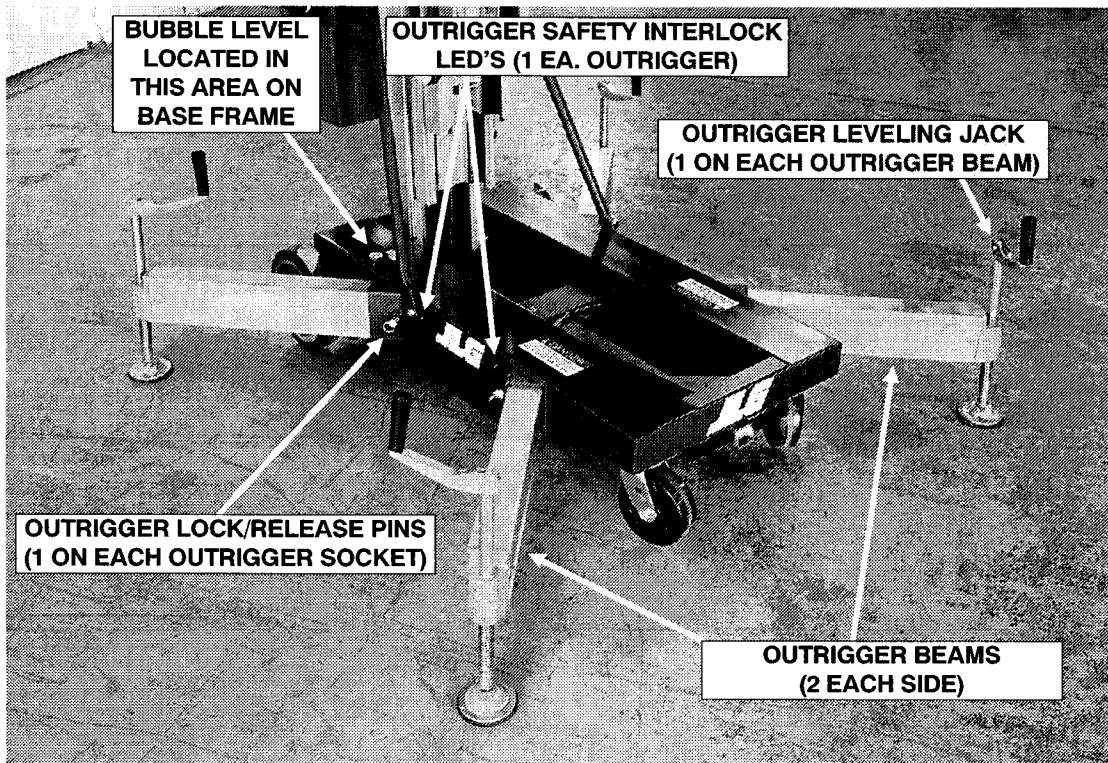

Figure 4-1. Outriggers Installed.

ger socket on base frame) will illuminate when the outrigger beam interlock contact (on bottom of each beam) is in contact with the socket contact (on bottom of each outrigger socket).

3. Crank the leveling jacks down evenly until all the wheels on the machine base are off the surface, check the bubble level on the base frame, then level machine accordingly (indicated by the bubble being centered in the bubble level).

⚠ IMPORTANT

After leveling machine, again check that all four wheels are off the floor. Also all four outrigger interlock LED's must be illuminated before power will be supplied to the platform control panel.

• **Platform Loading**

The platform maximum rated load capacity is shown on a placard located on the platform and is based upon the following criteria.

Maximum capacity for each model is as follows:

AM-19-AC	350 lb. (159 kg)
AM-19-DC	350 lb. (159 kg)
AM-24-AC	350 lb. (159 kg)
AM-24-DC	350 lb. (159 kg)
AM-30-AC	350 lb. (159 kg)
AM-30-DC	350 lb. (159 kg)
AM-36-AC	300 lb. (136 kg)
AM-36-DC	300 lb. (136 kg)

• **Platform Operation**

⚠ WARNING

DO NOT ATTEMPT TO RAISE THE PLATFORM UNLESS OUTRIGGERS ARE PROPERLY INSTALLED AND MACHINED IS LEVELED ON A SMOOTH, FIRM, AND LEVEL SURFACE FREE OF OBSTRUCTIONS AND HOLES.

1. Enter platform and close gate.

Note

On platform control panel the FUNCTION ENABLE (green button) must be depressed simultaneously with either the UP or DOWN button in order for these functions to work.

2. To raise platform up, depress FUNCTION ENABLE BUTTON (green) and platform UP but-

ton (top, white button) on control panel simultaneously. Upon reaching desired elevation level release UP and FUNCTION ENABLE buttons.

⚠ WARNING

ENSURE AREA BENEATH PLATFORM IS FREE OF PERSONNEL AND OBSTRUCTIONS PRIOR TO LOWERING PLATFORM.

3. To lower platform, depress FUNCTION ENABLE BUTTON (green) and platform DOWN button (bottom, white button) on control panel simultaneously. Upon reaching desired elevation level release DOWN and FUNCTION ENABLE buttons.

4-4. STOWING MACHINE

1. Ensure that platform is fully lowered, turn POWER ON/OFF key switch (on the Ground Control Station) to the OFF position.
2. Carefully lower base frame onto its wheels by turning the outrigger jack handles counterclockwise until machine wheels are lowered onto the ground, (before lowering check that no objects have fallen beneath machine to prevent tipping of machine).
3. Remove outrigger beams from outrigger sockets in base frame and place beams in stowage sockets on both sides of platform.

⚠ IMPORTANT

WHEN MOVING MACHINE PLEASE FOLLOW ALL SAFETY PRECAUTIONS DESCRIBED IN SECTION 1-5, "TRANSPORT SAFETY" OF THIS MANUAL. ALSO SEE SECTION 4-5, "TRANSPORTING AND LIFTING" FOR PROPER PROCEDURES FOR TRANSPORTING.

4. Move machine to a well-protected and well-ventilated area.
5. If necessary, cover the instruction placards, caution and warning decals so that they will be protected from hostile environment.
6. Chock at least two wheels when parking machine for an extended period of time.
7. Remove key from Ground Control Panel POWER ON/OFF key switch to disable machine from unauthorized use.

Note

If required, DC machine batteries should be charged in preparation for next work day in accordance with Section 2-7, "Battery Charging" (DC Machines).

4-5. TRANSPORTING AND LIFTING

• General

All AccessMaster (AM) models may be transported from worksite to worksite using any of the following methods:

- Pushing the machine around on its base wheels.
- Pushing the machine around in Tilt-Back mode. (See note following)
- Move with a forklift truck using the forklift pockets under the mast end of the baseframe.
- Load the machine on the back of a pickup truck using built-in load-bar/slide-pad assembly.

Note

Due to the stowed height of the AM-30 and AM-36 models, a permanently attached tilt-back assembly allows the operator to tilt the machine to move it through standard size doorways.

• Transporting by Pushing

(See Figure 4-2. & 4-3.)

The standard machine's base frame is equipped with load bearing wheels mounted on a straight axle at the mast end of the machine; and a pair of heavy duty swivel caster wheels mounted on the frame at the platform end of the machine. (Optional heavy duty locking swivel caster wheels are available and can be used in place of the straight axle wheels). It is important to closely follow the instructions mentioned in the following WARNING note to ensure safe transport of unit when pushing.

⚠ WARNING

FAILURE TO HEED THE FOLLOWING INSTRUCTIONS COULD CAUSE THE UNIT TO TIP OVER OR BE HARD TO CONTROL WHEN BEING MOVED WHICH COULD RESULT IN SERIOUS INJURY OR DEATH DUE TO BEING PINNED OR CRUSHED BY UNIT.

- KEEP CLEAR FROM BEHIND AND IN FRONT OF THE UNIT. (FIG. 4-2.)
- WALK BESIDE THE UNIT AND HOLD ONTO THE SIDE OF THE PLATFORM. (FIG. 4-2.)
- ON A LEVEL SURFACE, ALWAYS TRAVEL WITH THE PLATFORM END LEADING THE WAY. (FIG. 4-2.)

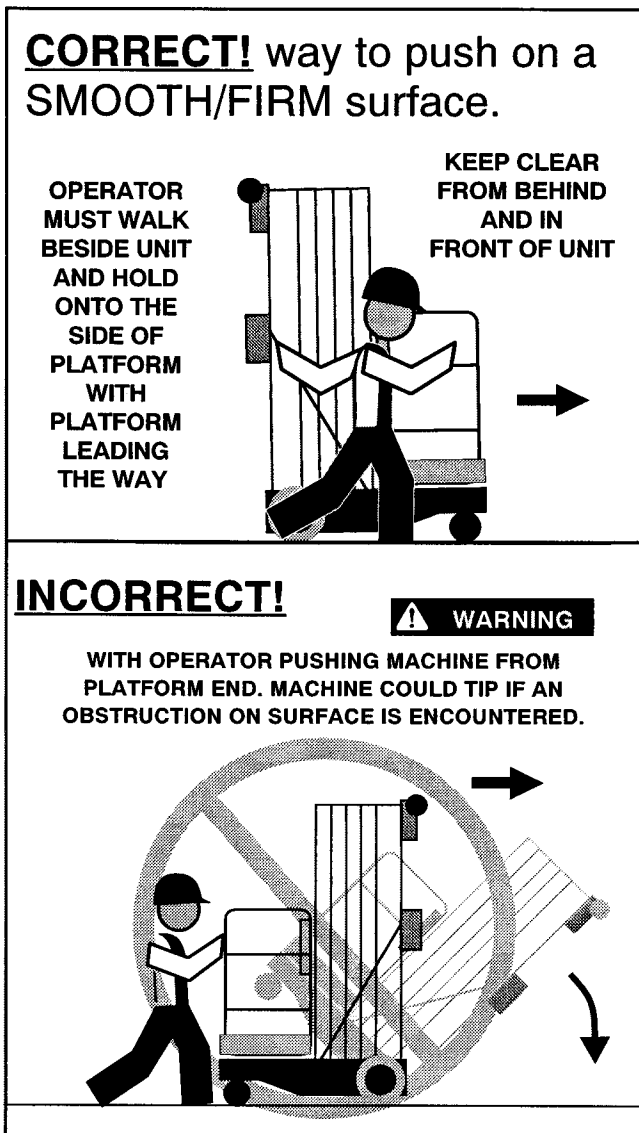

Figure 4-2. Pushing Machine on a SMOOTH, FIRM surface.

- ON A SLOPE, ALWAYS TRAVEL WITH THE PLATFORM END ON THE LOW SIDE OF THE SLOPE. (FIG 4-3.)
- TWO PEOPLE ARE REQUIRED ON SLOPES UP TO 5 DEGREES, A FORKLIFT MUST BE USED WHEN MOVING UNITS ON SLOPES GREATER THAN 5 DEGREES.
- NEVER POSITION THE UNIT SIDWAYS ON A SLOPE.
- DO NOT MOVE UNIT ON SOFT OR UNEVEN SURFACES, OR OVER OBSTRUCTIONS, BUMPS, DEBRIS, ETC.

CAREFULLY REVIEW ALL SAFETY PRECAUTIONS NOTED IN SECTION 1-5, "TRANSPORT SAFETY",

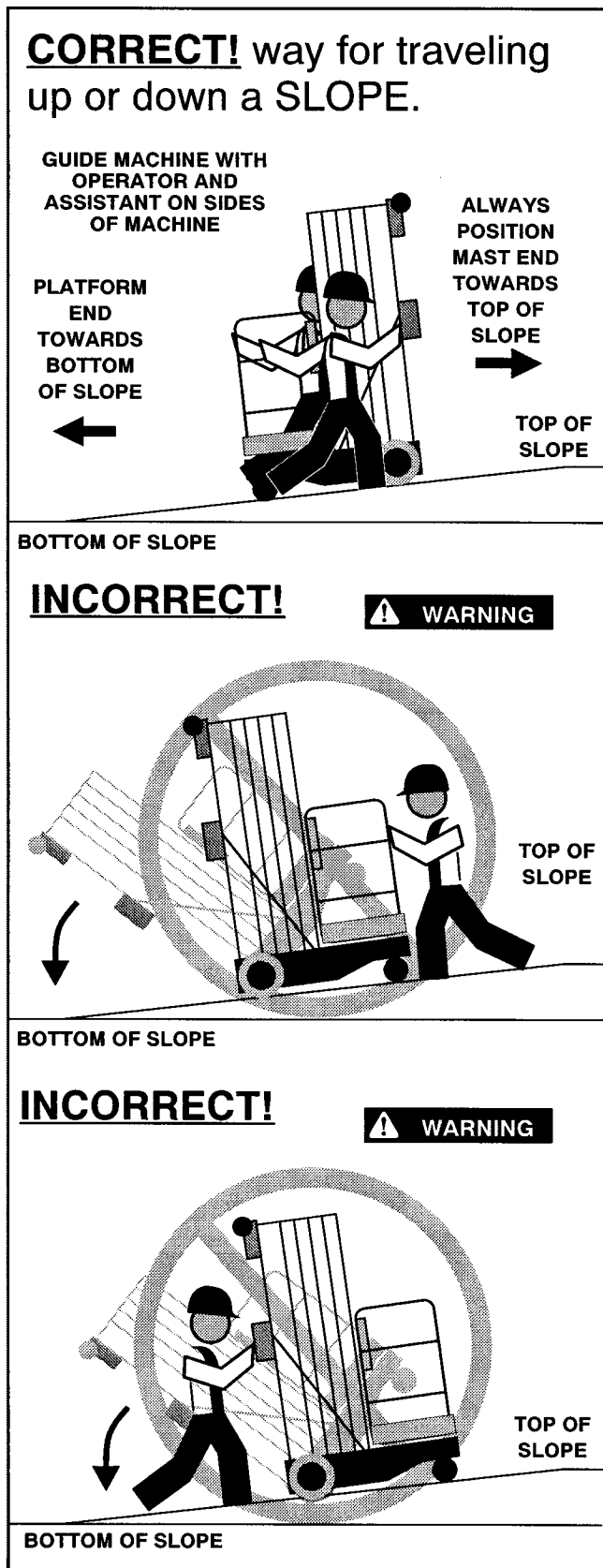

Figure 4-3. Pushing Machine on a SLOPE.

BEFORE ATTEMPTING TO MOVE MACHINE.

IMPORTANT

BEFORE MOVING A MACHINE BY PUSHING, IF NECESSARY REMOVE OUTRIGGERS AND SECURE ANY TOOLS OR OBJECTS WHICH MAY OTHERWISE FALL OFF AND CAUSE INJURY OR BE DAMAGE DURING TRANSPORT.

• **Tilt-Back Assembly Set-up**

(See Figure 4-4.)

1. Move machine to an area clear and free of obstructions in direction of machine tilt.

IMPORTANT

PLATFORM MUST BE FULLY LOWERED, AND OUTRIGGER BEAMS MUST BE REMOVED FROM OUTRIGGER SOCKETS IN BASE FRAME TO PERFORM THIS OPERATION, (PREFERABLY PLACED IN STORAGE SOCKETS ON EACH SIDE OF PLATFORM).

2. Hold on to the tilt-back assembly and remove the release pin (located on the mast support crossbar, see Fig. 4-4.) from the mast support bracket on the back of mast.
3. Carefully lower the tilt-back assembly as far as it will go.
4. Grasp either of the gas spring assemblies on the tilt-back assembly and pull upward out of spring clip.
5. Guide the groove pins (on the unattached end of the gas spring assy.) into the slot on the mast crossbar support bracket attached to the rear of the mast (see Fig. 4-4.). Secure gas spring to mast support bracket with a safety pin provided, (stowed in hole in mast support bracket cross bar). Do the same with the other side gas spring assembly.
6. To tilt machine back on the tilt-back assembly, go to the platform end of the machine and locate the T-handle lifting bar just below the base frame under front of platform (see Fig. 4-4.).
7. Lift the spring-loaded locking pin (inside base frame under platform) on the outer sleeve of the T-handle bar and slide the handle out until the locking pin locks the T-handle bar in the extended position.

IMPORTANT

ON DC MODELS ENSURE BATTERY BOX/CHARGER ASSEMBLY IS NOT OBSTRUCTED AND IS CLEAR TO SWING ONCE MACHINE IS TILTED.

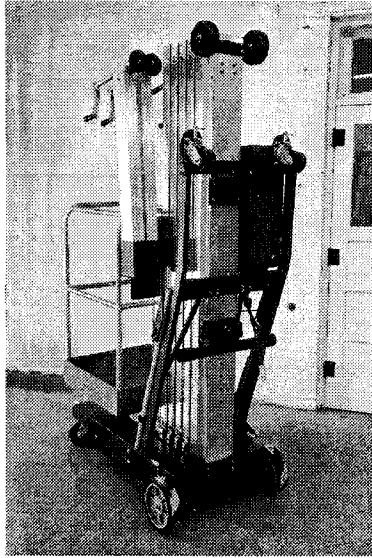

Tilt Back In Stowed Position



Remove Release Pin While Holding Base

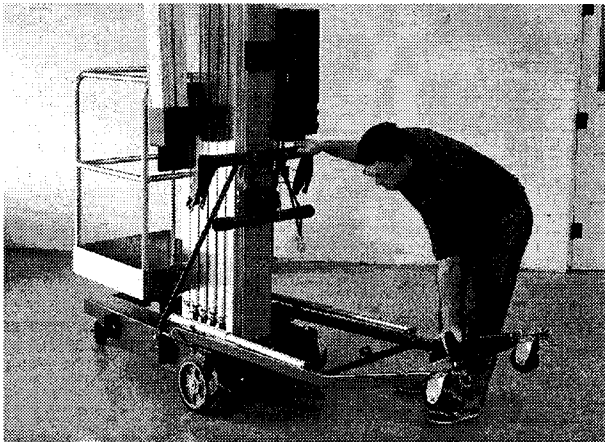

Lower Base Assembly Down

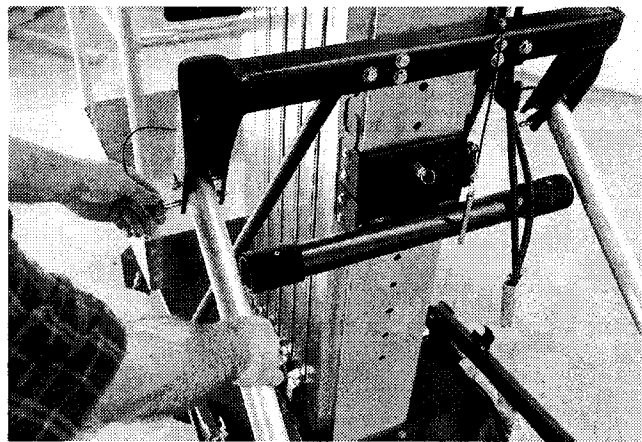

Attach Gas Cylinders to Support Brackets and Secure with Safety Pins

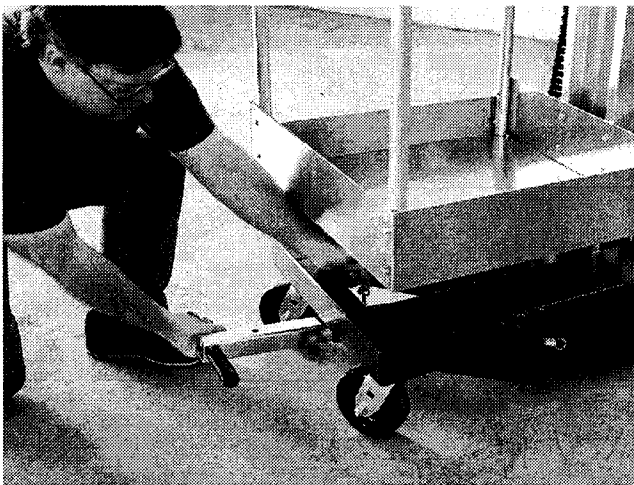

Pull Out T-Handle Lifting Bar On Base

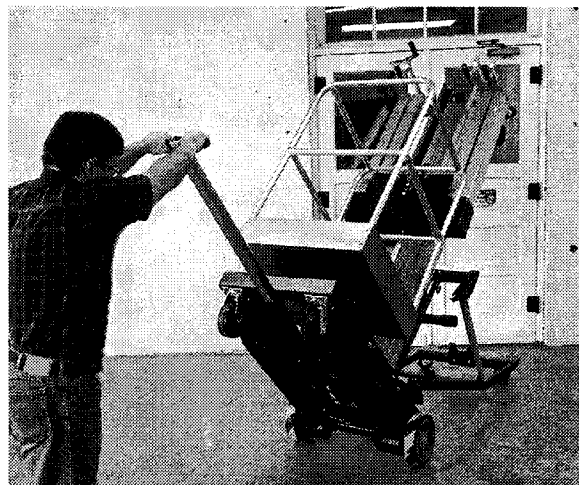

Lift Unit Into Tilt Back Position

Figure 4-4. Tilt Back Assembly Set-up.

⚠ CAUTION

BEFORE PLACING MACHINE IN THE TILT-BACK POSITION BE SURE TO REMOVE OR SECURE ANY TOOLS OR OTHER ITEMS PLACED ON THE MACHINE WHICH MAY OTHERWISE FALL OFF AND BE DAMAGED, OR CAUSE INJURY TO NEARBY PERSONNEL.

8. With both hands on the grips of the T-handle lifting bar, carefully lift up on the platform end of the base pivoting the machine on the rear wheels until it engages the gas spring assembly, keep lifting until machine rests fully on the tilt-back assembly.
9. The machine may now be moved around on the tilt-back assembly. The castor wheels on the tilt-back assy. can be allowed to rotate freely or can be locked in position at 90 degree intervals.

- **Pickup Truck Transporting**

(See Figure 4-5.)

All AM models are capable of being transported in the bed of a standard pickup truck. The lifts can be easily loaded and unloaded by one person, See Fig. 4-5. showing an operator loading an AM model into the bed of a pickup truck.

Note

It is recommended that 3/4" thick plywood be placed in the truck bed and out onto tailgate. This helps with rolling machine into the truck bed and also helps distribute the machine weight more evenly across the truck tailgate to avoid tailgate damage.

1. (STEP 1) Park truck on a firm, smooth, level surface with tailgate open. Roll machine over to truck tailgate with the mast end (*back of machine*) towards tailgate.

⚠ CAUTION

REMOVE OR SECURE ANY ITEMS ATTACHED TO THE MACHINE THAT MAY OBSTRUCT ENTRY OF THE LIFT ONTO THE TRUCK BED; OR THAT MAY FALL OFF AND BE DAMAGED OR CAUSE INJURY TO YOURSELF OR NEARBY PERSONNEL.

2. On DC machines the battery charger/ storage box must be removed and placed on the truck separately for transport.
3. (STEP 1) Adjust the load-bar/slide-pad assembly on the lower rear portion of the mast so it sets at approximately 2 to 3 inches above tailgate height. Adjust by pulling out on the spring loaded locking pin and raising or lower-

ing the load-bar/slide-pad assembly. **BE CERTAIN THE LOAD-BAR/SLIDE-PAD ASSEMBLY IS LOCKED IN PLACE AT PROPER HEIGHT.**

4. (STEP 1) Push machine in against tailgate, until snug.
5. (STEP 2) On platform end of machine, extend T-handle load lifting bar out from under base frame by lifting the spring loaded locking pin. Extend the handle out until the locking pin aligns with hole in T-handle bar (*when extended*). Lock lifting bar in place.
6. (STEP 3) Begin lifting machine onto tailgate of truck with the T-handle lifting bar. **As machine begins to tilt be certain the load-bar pads are properly engaging the truck tailgate.**
7. (STEP 4) Continue lifting and pushing machine onto the truck tailgate. As the load bar pivots the machine horizontally onto the truck bed, firmly grasp the machine by the base frame (STEP 5) pushing machine into truck bed on its attached wheels.
8. (STEP 6) With machine loaded, secure to truck bed with rope or tie down hooks strong enough to limit any machine movement while transporting.

To unload machine from truck bed, reverse loading instructions above and as shown in Figure 4-5.

- **Lifting**

If it becomes necessary to lift the complete machine, use suitable lifting equipment capable of handling the weight of the machine as noted below.

Note

Fork lifts, cranes, chains, slings, etc. must be capable of handling the following weights:

AM-19-AC - 660 lbs. (299 kg)

AM-19-DC - 725 lbs. (329 kg)

AM-24-AC - 700 lbs. (318 kg)

AM-24-DC - 765 lbs. (347 kg)

AM-30-AC - 850 lbs. (386 kg)

AM-30-DC - 915 lbs. (415 kg)

AM-36-AC - 955 lbs. (433 kg)

AM-36-DC - 1,020 lbs. (463 kg)

Note

All AM models are equipped with forklift pockets at the mast end of the frame for ease in transporting the unit. Also an optional crane hook (AM-HK) is available. Do not attempt to lift with a crane without the optional crane hook (AM-HK).



STEP 1
Back unit up to truck and adjust load-bar/slide-pad.

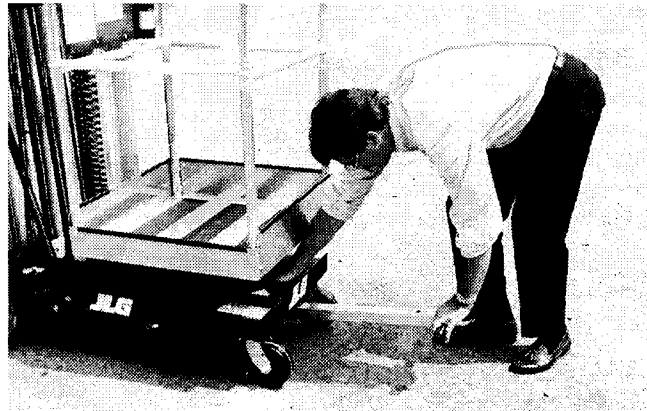

STEP 2
Extend lifting bar out from under front of unit.

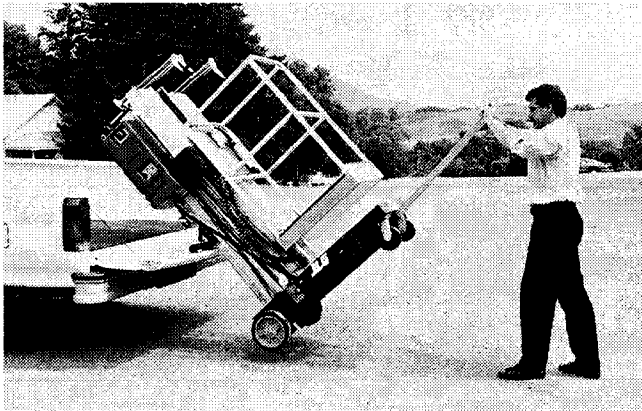

STEP 3
Start lifting machine onto tailgate.

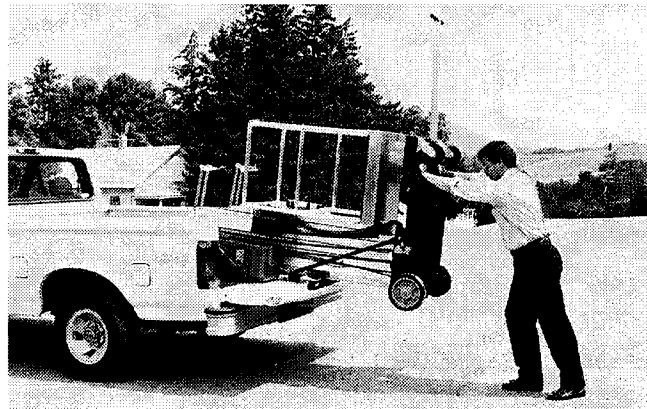

STEP 4
Continue lifting and pushing onto truck bed.

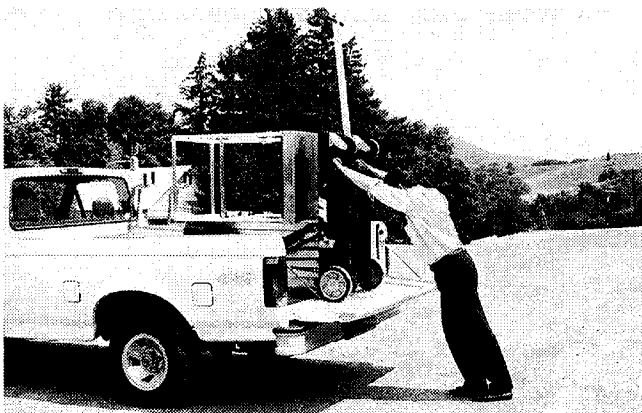

STEP 5
Push all the way into truck bed.

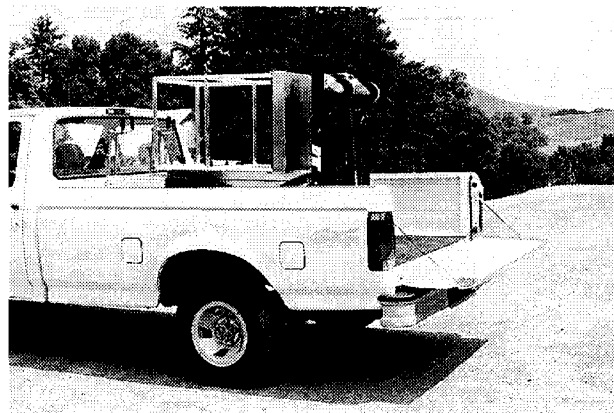

STEP 6
With machine completely in bed,
tie down machine.

Figure 4-58. Loading Machine onto Truck for Transport.

5-1. OPTIONAL EQUIPMENT

The Accessmaster AM models are available with the following optional equipment:

- 110 Volt AC Model
- 220 Volt AC Model
- 12 Volt DC Model with 110 Volt Input Battery Charger
- 12 Volt DC Model with 220 Volt Input Battery Charger
- 22" x 22" Platform
- Step-in Molded Platform w/Swing-up Gate
- Tool Tray
- Fluorescent Tube Caddy
- Crane Hook
- Straddle Extension Kit (Requires Straddle Adapter)
- Ladder for Straddle Extension
- Extra Power Pack (Battery, Charger & Case)
- Removeable Rear Swivel Locking Castor Wheels

5-2. AM-SE - STRADDLE EXTENSION KIT – SET-UP AND OPERATION

• Description

This sub-section contains instructions for installation of the straddle extension adaptor to both AC and DC machines. Also included are instructions for set-up and operation of the straddle extension kit.

The AM-SE straddle extension kit increases the versatility of the AccessMaster AM models by providing a bridge for access to areas where obstacles such as rows of seats, machines, counters or stairwells are encountered. The double-winch elevating system permits one man setup and swivel casters allow the coupled configuration to be easily maneuvered. The unit can be quickly disassembled for compact storage.

The straddle extension provides clearance of up to 48 inches (1.2m) and the length for caster spacing is adjustable from 104 to 128 inches (2.6m to 3.3 m). The AccessMaster AM models are fully operational at full rated capacity when used in combination with the straddle extension.

• Straddle Adaptor Wiring Kit

AC & DC MODELS

The straddle wiring kit for both the AC & DC (AM) models includes the following parts:

1. One (1) wiring harness with two (2) female - three (3) prong (twist-lock) connectors on one end which are wired together into three (3) 16 gauge wires - Red, White and Green - two with fork terminals and one with butt splice (14 - 16 ga.) terminal, ready for connection in the AC control box.
2. Two (2) Spring Clamps.
3. Four (4) #10 x 1/2" long self-tapping screws.
4. One (1) 3/8" I.D. \ 1/2" O.D grommet.

To install wiring kit, proceed as follows;

1. Before unplugging AC unit power cord or disconnecting the DC unit power connector (*at battery box*), set-up machine - i.e. install outriggers and level machine. Raise the platform approximately three or four feet while standing outside platform on floor, this will allow access to the base frame area under platform.

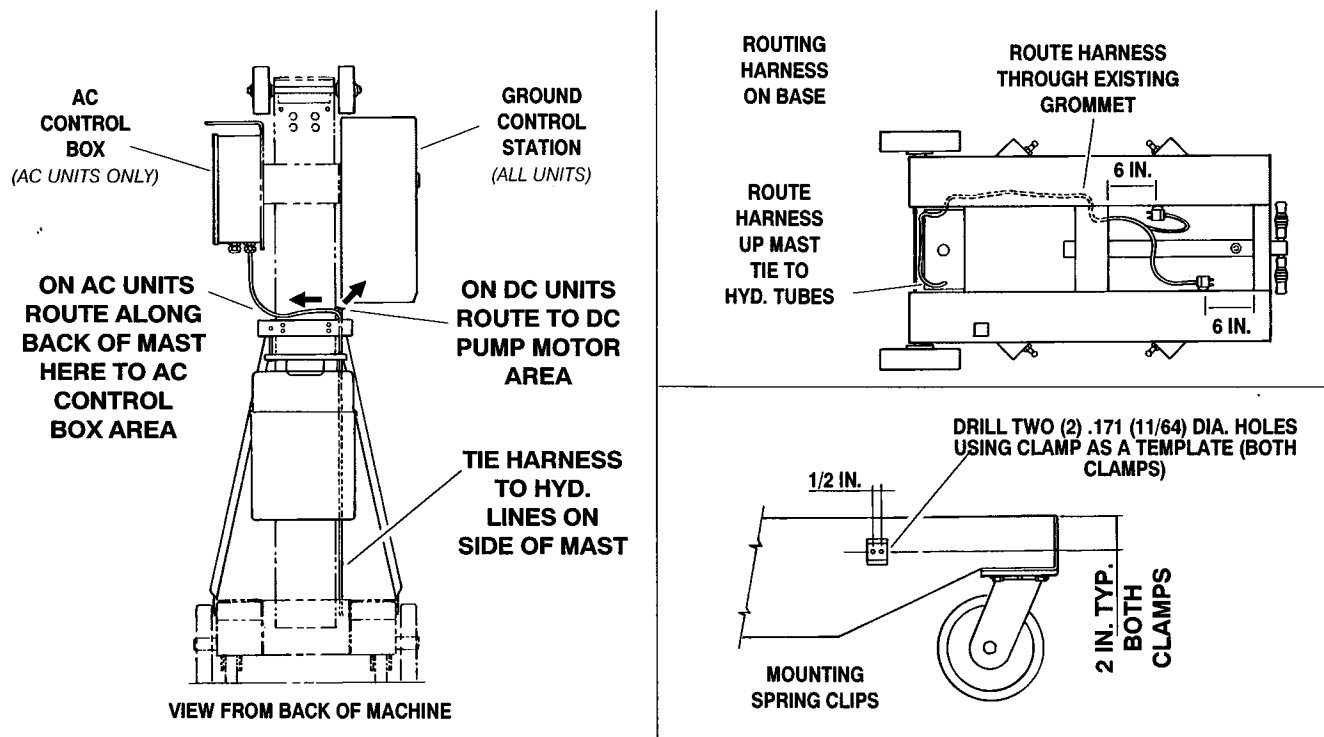

Figure 5-1. Straddle Adaptor Wiring Harness Installation.

2. Drill four (4) .171 diameter (11/64") holes, two (2) per spring clip in base frame, locate holes at dimensions as shown in Figure 5-1.
3. Install the spring clips to the base frame at location of drilled holes, using two (2) #10 x 1/2" long self-tapping screws per spring clip.

⚠ DANGER

BEFORE WORKING INSIDE OF THE AC CONTROL BOX BE CERTAIN ALL ELECTRICAL CURRENT TO THE BOX IS DISCONNECTED BY UNPLUGGING THE UNIT POWER CORD.

⚠ IMPORTANT

ON DC POWERED MACHINES DISCONNECT THE MAIN POWER SUPPLY CONNECTOR ON THE SIDE OF THE BATTERY STORAGE/CHARGER BOX. THIS WILL PREVENT ANY POSSIBILITY OF GROUNDING ELECTRICAL CIRCUIT AND CAUSING DAMAGE TO UNIT WHILE WORKING AROUND ELECTRICAL COMPONENTS.

4. Press the two (2) - three (3) prong connector ends into the spring clips mounted on the base frame and route the wiring harness through the base frame and up hydraulic lines on side of mast. Tie wiring harness to the hydraulic lines

and route to either the AC Control Box on AC voltage models or the Ground Control Station on DC models, as shown in Figure 5-1.

AC MODELS ONLY (See Figure 5-2.)

- 5a. On the AC control box loosen an existing strain relief fitting large enough to accommodate the diameter of the adaptor wiring harness and existing wiring.
- 6a. Install the wiring harness through the strain relief fitting and into the box. Retighten fitting.
- 7a. Attach the RED (16 GA.) wire - fork terminal to the (+12v DC) number one (1) terminal screw on the terminal strip. (See Figure 5-2.)
- 8a. Attach the GREEN (16 GA.) wire - fork terminal to the (GROUND) number seven (7) terminal screw on the terminal strip.
- 9a. Butt splice the WHITE (16 GA.) wire to the YELLOW wire (WIRE LUG 86) on the out-rigger interlock relay located beside the terminal strip inside the control box.
- 10a. Recheck all connections for tightness, clean out any debris from box and close AC box door.

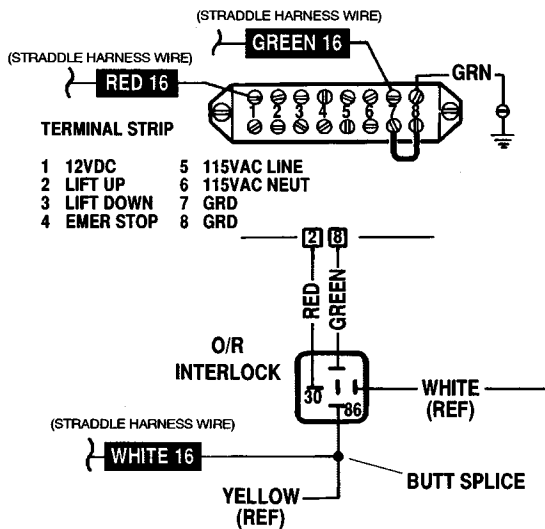

Figure 5-2. Straddle Adaptor - AC Control Box wiring connections.

11a. To verify installation, set-up and assemble straddle extension kit as described in “Mounting” sub-section following. If outrigger interlock LED’s on the straddle extension are illuminated when kit is completely assembled, and power is supplied to the platform, then installation is complete.

DC MODELS ONLY (See Figure 5-3.)

- 5b.** Remove the bolts from the cover on the ground control station and lay the cover aside.
- 6b.** Route the wiring harness into the area around the power relay and the interlock relay above the pump motor.
- 7b.** Connect the RED (16 GA.) wire - fork terminal from the straddle adaptor wiring harness to the power relay post on which the BLUE wire from the ground controls (*Power - on/off and Stop Button*) are attached.
- 8b.** Connect the GREEN (16 GA.) wire - fork terminal from the straddle adaptor wiring harness to the power relay post on which the BLACK cable (*ground from main battery connector*) and the GREEN wires (*one off an adjacent relay post and one running to the interlock relay*) are attached.
- 9b.** At the outrigger interlock relay (*at top - to right of ground controls*) butt splice the WHITE (16 GA.) wire - with butt splice end from the straddle adaptor wiring harness to

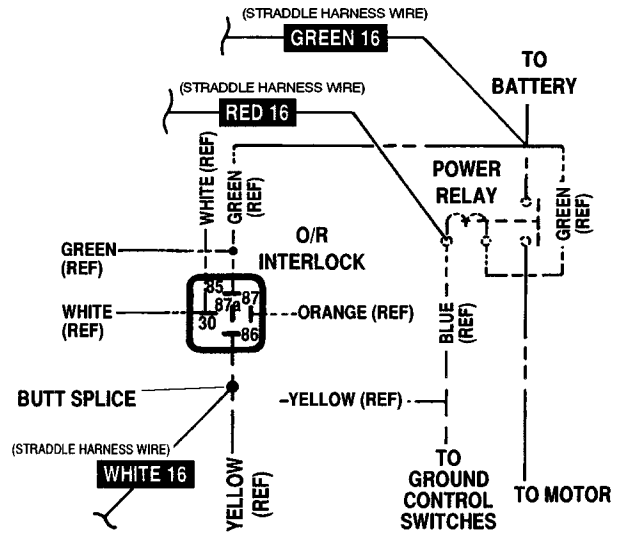

Figure 5-3. Straddle Adaptor - DC Ground Control Station wiring connections.

the YELLOW wire (terminal 86) on the outrigger interlock relay.

- 10b.** Recheck all connections for tightness then reinstall ground control station cover.
- 11b.** To verify installation, set-up and assemble straddle extension kit as described in “Mounting” sub-section following. If outrigger interlock LED’s on the straddle extension are illuminated when kit is completely assembled, and power is supplied to the platform, then installation is complete.

• Straddle Extension - Components

The AccessMaster® AM-SE Straddle Extension kit can be set up by one person without tools. The AM-SE kit consists of eight (8) structural components. Those eight (8) components are:

- 1. Two (2) extendable side lifting rails.
- 2. Two (2) end straddle supports on locking swivel caster wheels, each with (*hand cranked*) lifting winch and winch cables, outrigger interlock - retractable cable reel and quick-release safety pins.
- 3. Four (4) outrigger (pup) beams which interconnect the straddle extension side lifting rails with the AccessMaster® base outrigger sockets.

• Mounting - Straddle Ext. to AccessMaster

(See Figure 5-4.)

1. Near work area find a suitable area large enough to assemble the AccessMaster® unit to the Straddle Extension Kit. Assembly area should be a smooth, firm, level surface on which the assembled straddle extension and AccessMaster® unit can be easily maneuvered.
2. Locate both extendable side lifting rails and the four (4) (pup) outrigger beams.
3. Start with either side and install one (1) of the (pup) outrigger beams into an outrigger socket in the AccessMaster® base. Push it in until the locking pin secures the (pup) beam in place.
4. Next pick-up one (1) of the side lifting rails (position with the outrigger sockets on the bottom), align the (pup) outrigger beam installed in previous step with the appropriate side lifting rail outrigger socket and slide the side lifting rail onto the (pup) outrigger beam.

5. On the same side lifting rail install the remaining (pup) outrigger beam into the side lifting rail socket and align with the AccessMaster® base outrigger socket. Push (pup) beam in until the locking pin in the AccessMaster® base secures the (pup) beam in place.
6. Mount the remaining side lifting rail by repeating the instructions in steps 4 and 5.
7. Next locate either end straddle support, (mount end straddle support with the winch handle positioned to outside), align the two vertical rails of the end straddle support with the adjust bracket opening on ends of lifting rails.

Note

Lock the castor wheels on the bottom of the end straddle supports so they are parallel with the outrigger sockets. This will help to keep the end straddle support stable during assembly.

8. Insert vertical rails into the adjust brackets (in against the slide pads), and insert an adjust bracket end cap (with slide pad against vertical

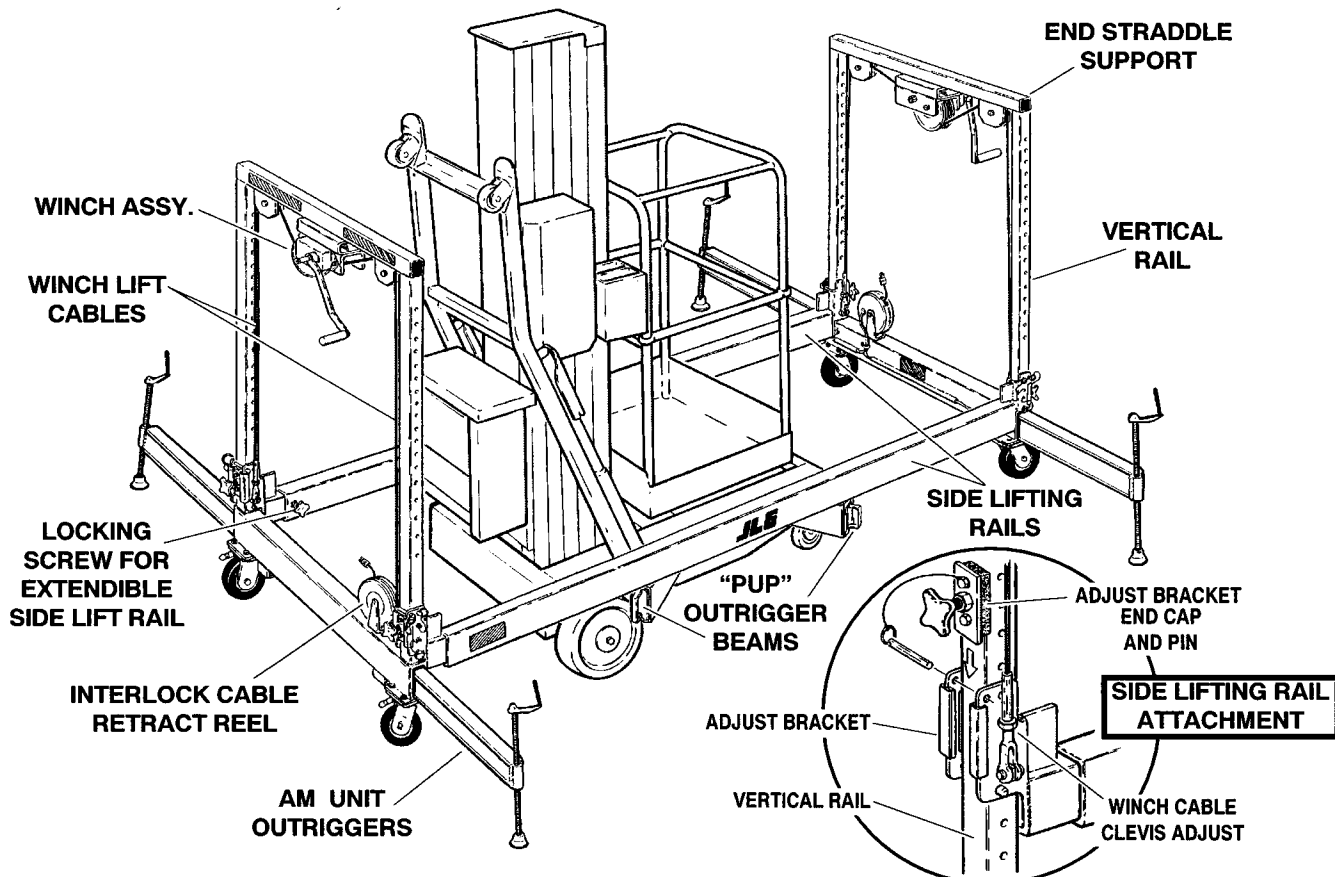

Figure 5-4. Straddle-Extension Component Assembly.

rail) into the slot on the adjust brackets on both side rails.

9. Secure end caps with the quick-release pin wired to the end cap, install pin into hole in adjust bracket just above end cap. (See Figure 5-4. and 5-5.)
10. Repeat steps five, six and seven for other end straddle support.
11. At both end straddle supports, attach the winch cable clevis ends to the lifting lugs (*on the side lifting rail - adjust brackets*), using the quick-release pins attached to winch cables.
12. Turn winch handle clockwise just enough to start lifting side rails. Observe winch cables, both cables must be lifting evenly.

If not lifting evenly, **adjust slack out of long cable** using the following steps:
 - a. Lower side rails by turning winch handles counter-clockwise enough to remove any tension on the winch cables.
 - b. Remove the quick-release pin securing the winch cable clevis to the lifting lug on the side rail adjust bracket.
 - c. Loosen the jam nut on the threaded cable end and turn the clevis end clockwise to shorten the cable.
 - d. Before tightening the jam nut re-install the winch cable to the side rail lifting lug with the quick release pin.
 - e. Turn winch handle to start lifting side rails, again observe winch cables. If cables are lifting evenly, retighten jam nut on threaded end of winch cable. If not lifting evenly repeat steps (a) through (e) until properly adjusted.
13. Connect the outrigger interlock cable ends (*male*) from the retractable reels (*mounted on both end straddle supports*) to the connector ends (*female*) mounted on the AccessMaster® base frame under the platform.

• Positioning Straddle Unit and Lifting AccessMaster® Unit

IMPORTANT

WHEN EXTENDING SIDE LIFTING RAILS, DO NOT EXTEND RAILS INTO THE RED ZONE PAINTED ON THE RAILS.

14. The AccessMaster® and Straddle Extension unit can now be rolled into position where needed. Make any necessary adjusts to the Straddle Extension, (i.e. extend side rails or lifting side rails with winch enough to raise the AccessMaster® unit over any obstacles (i.e. seat rows, etc.) before setting in position.

Use the following steps to lift the AccessMaster® Unit:

Note

When raising or lowering side rails, keep rails (*and AccessMaster® Unit*) as level as possible to avoid binding of vertical rails in adjust bracket slide pads.

- a. Firmly grasp handle on winch assembly and crank winch arm clockwise lifting side rails. Crank each end so side rails will lift evenly.
 - b. When desired height has been reached, align holes in side rail adjust brackets and vertical rails to allow the quick-release pins to be inserted (See Figure 5-5.), securing side rails in position.
 - c. When all pins are inserted and locked, crank winch handles counter-clockwise releasing tension on the winch cables.
 - d. Remove any end to end play in straddle unit by tightening the adjust bracket end cap adjustment screws, (See Figure 5-5.).
15. With AccessMaster®, Straddle Extension assembly in position, install outrigger beams from AccessMaster® unit into the outrigger sockets on each end straddle support.
 16. Using the leveling jack on each outrigger beam raise straddle unit until all Straddle Extension and AccessMaster® castor wheels are off ground.
 17. Level both the AccessMaster® and Straddle Extension with leveling jacks according to the bubble level indicator located on the AccessMaster® base frame.
 18. Turn on the power switch at the ground control station on AccessMaster® unit. Walk around unit and observe if the outrigger interlock LED's are illuminated. (*LED's are located on the inside of frame on end straddle supports, just above each castor wheel*).
 19. If all four (4) interlock LED's are illuminated on the straddle extension, power is then supplied to the AccessMaster® platform controls.

20. Recheck each of the following to insure the lift is properly set-up and ready to use:
- All “pup” outrigger beam adapters are locked and secured.
 - Side rail adjust bracket locking pins are installed and tension is released from winch cables.
 - Adjust bracket end cap adjust screws have been tightened to remove any end to end play in straddle unit.
 - Straddle and AccessMaster® are leveled according to bubble level indicator on AccessMaster® unit.
 - Review the instructions for safe operation of the lift and follow all safety and maintenance procedures.

Note

The AM-SE Ladder (option) is available to ease entry into the AccessMaster platform. The ladder is attached to either straddle side lifting rail on the straddle extension.

⚠ DANGER

DO NOT ATTEMPT TO MOVE THE STRADDLE UNIT AROUND WITH THE ACCESSMASTER® PLATFORM IN A RAISED POSITION.

• **Lowering AccessMaster® on Straddle Unit**

- If necessary remove the outriggers and move the straddle and AccessMaster® unit to an area which will allow access to the straddle end supports.
- Loosen adjust screws on adjust bracket end caps (See Figure 5-5.).
- Crank the winch handle on each winch (located on straddle end supports) clockwise, just enough to start raising the side lifting rails, lifting the weight off of the quick-release pins installed through the side rail adjust bracket and the straddle end support vertical rails.
- Remove **ONLY** the two (2) side rail quick-release pins installed through each side lifting rail adjust bracket and the straddle end support vertical rails at all four (4) corners of the straddle extension. (See Figure 5-5.)

* **⚠ WARNING**

DO NOT REMOVE THE END CAP PIN FROM THE ADJUST BRACKET UNTIL THE ACCESSMASTER® UNIT IS FULLY LOWERED TO THE GROUND ON ITS

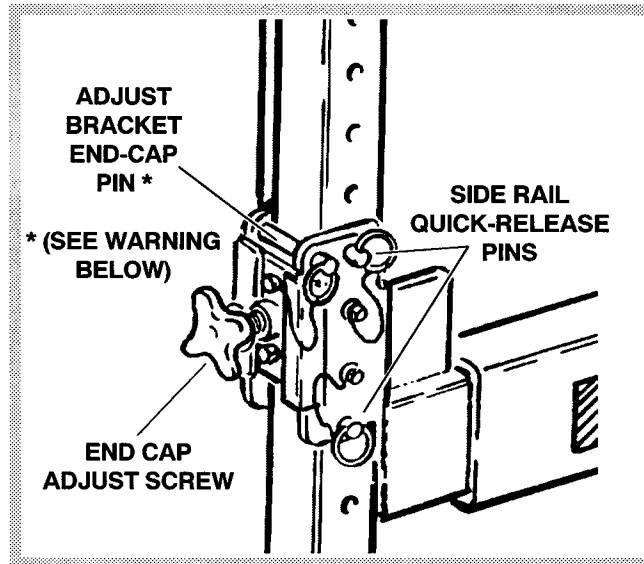

Figure 5-5. Lowering AccessMaster® on Straddle Unit - Side Lifting Rail Quick-Release Pins.

CASTOR WHEELS, AND STRADDLE END SUPPORTS ARE BEING DISASSEMBLED FROM SIDE RAILS. (SEE FIGURE 5-5.)

- Carefully lower the side lifting rails (and AccessMaster unit) evenly, by turning the winch handle at each straddle end support counter-clockwise until the AccessMaster® Unit is fully lowered to the ground on its castor wheels.

• **Straddle and AccessMaster® Unit Disassembly**

Once the AccessMaster® unit is lowered on its castor wheels and outriggers are removed, disassembly of the unit is accomplished by reversing the procedures in previous sub-section, “Mounting - Straddle Extension to AccessMaster® from steps 1 through 11.

Note

Lock the castor wheels on the bottom of the end straddle supports so they are parallel with the outrigger sockets. This will help to keep the end straddle support more stable during disassembly.

6-1. GENERAL INFORMATION

This section provides information on procedures to be followed, and systems and controls to be used in the event an emergency situation is encountered during machine operation. Prior to operation of the machine and periodically thereafter, the entire operating manual, including this section, should be reviewed by all personnel whose responsibilities include any work or contact with the machine.

6-2. EMERGENCY CONTROLS AND THEIR LOCATIONS

⚠ WARNING

CHECK MACHINE DAILY TO MAKE SURE EMERGENCY STOP SWITCHES ARE IN PLACE AND OPERATIONAL. AND THAT APPLICABLE INSTRUCTIONS ARE IN PLACE AND LEGIBLE.

• **Platform Emergency Stop Switch**

This large red button is located on the platform control box and, when depressed, will immediately stop the machine from the platform.

• **Ground Emergency Stop Switch**

The ground Emergency Stop switch (RED button) is located on the Ground Control Panel beside the Power On/OFF Key switch. When depressed, will immediately stop the machine.

• **Manual Descent Knob**

The manual descent knob is used in the event of either a total power failure, or if the operator in the platform cannot lower the platform himself. The manual descent knob (RED knurled) is located on the electric/hydraulic pump-motor unit at the Ground Control Station. To lower the platform, turn the manual descent knob counterclockwise opening the valve. Turn the knob clockwise to stop descent or to close the valve. (The platform will be lowered, unpowered, using gravity.)

6-3. EMERGENCY OPERATION

• **Use of Ground Controls.**

IMPORTANT

KNOW HOW TO USE THE GROUND CONTROLS IN AN EMERGENCY SITUATION.

⚠ DANGER

BEFORE TOUCHING ANY PART OF THE MACHINE IN AN EMERGENCY SITUATION, FIRST DETERMINE IF MACHINE IS IN CONTACT WITH OR CLOSE PROXIMITY TO AN ELECTRICALLY CHARGED CONDUCTOR. THIS MACHINE DOES NOT PROVIDE PROTECTION FROM CONTACT WITH OR PROXIMITY TO AN ELECTRICALLY CHARGED CONDUCTOR. (SEE ELECTROCUTION HAZARD, SECTION 1-3.)

Ground personnel must be thoroughly familiar with the machine operating characteristics and the ground control functions. Training should include operation of the machine, review and understanding of this section and hands-on operation of the controls in simulated emergencies.

• **Operator Unable to Control Machine**

IMPORTANT

IF THE PLATFORM OPERATOR IS PINNED, TRAPPED OR UNABLE TO OPERATE OR CONTROL THE MACHINE, USE THE FOLLOWING INSTRUCTIONS AS A GUIDELINE.

1. Operate the machine from the ground controls **ONLY** with the assistance of other personnel and equipment (cranes, overhead hoists, etc.) as may be required to safely remove the danger or emergency condition.
2. Other qualified personnel in the platform may use the platform controls. **DO NOT CONTINUE OPERATION IF CONTROLS DO NOT FUNCTION NORMALLY.**
3. Cranes, forklift trucks or other equipment which may be available are to be used to help remove the platform occupant and stabilize motion of the machine in case machine controls are inoperable or platform cannot be lowered with the emergency/manual decent valve.

(continued next page)

• Platform Caught Overhead

If the platform becomes jammed or snagged in overhead structures or equipment, do not continue operation of the machine from either the platform or the ground until the operator and all personnel are safely moved to a secure location. Only then should an attempt be made to free the platform using any necessary equipment and personnel. Do not operate controls to cause one or more outrigger jacks to leave the ground.

• Righting of Tipped Machine

Before righting a tipped machine, check machine for any damage which may prevent it from setting properly on its base wheels once in a vertical position, (i.e. base wheels damaged, base frame distorted, etc.). Use a crane, forklift or other suitable lifting equipment and carefully lift the machine to an upright position.

• Post-Incident Inspection

Following any incident, thoroughly inspect the machine and test all functions. Do not lift platform above 10 feet (3 meters) until you are sure that all damage has been repaired and that all controls and machine components are operating correctly.

6-4. INCIDENT NOTIFICATION

It is imperative that JLG Industries, Inc. be notified immediately of any incident involving a JLG product. Even if no injury or property damage is evident, the Product Safety and Reliability Department at the factory should be contacted by telephone and provided with all necessary details.

JLG Phone: (717) 485-5161
(8am till 4:45pm EST)

It should be noted that failure to notify the Manufacturer of an incident involving a JLG Industries product within 48 hours of such an occurrence may void any warranty consideration on that particular machine.

7-1. CAPACITIES

- **Hydraulic Oil Reservoir**

AC Models – 5 qts. U.S. (4.7 ltr.)

DC Models – 5 qts. U.S. (4.7 ltr.)

7-2. COMPONENT DATA

- **Hydraulic Pump/Electric Motor Assembly**

AC Models – 115 Volt AC motor

Pump Displacement – 0.49 in.³/rev.
(0.8 cm²/rev.)

Pump Output – 0.6 gpm (2.3 lpm) @ 2200psi
(152 bar)

Pressure relief – 2800 psi (193 bar)

DC Models – 12 Volt DC motor.

Pump Displacement – 0.49 in.³/rev.
(0.8 cm²/rev.)

Pump Output – 0.6 gpm (2.3 lpm) @ 2200 psi
(152 bar)

Pressure relief – 2800 psi (193 bar)

Batteries (1) – DC Models.

12 Volt – 165 Amp (min.) – Deep Cycle
Marine - RV

Battery Charger – DC Models.

115 Volts AC – 50/60 Hz input

220 Volts AC – 50/60 Hz input

12 volt output w/12 hour timer

7-3. PERFORMANCE DATA.

- **Platform Capacity**

AM19-AC – 350 lb. (159 kg)

AM19-DC – 350 lb. (159 kg)

AM24-AC – 350 lb. (159 kg)

AM24-DC – 350 lb. (159 kg)

AM30-AC – 350 lb. (159 kg)

AM30-DC – 350 lb. (159 kg)

AM36-AC – 300 lb. (136 kg)

AM36-DC – 300 lb. (136 kg)

- **Machine Weight**

AM-19-AC - 660 lbs. (299 kg)

AM-19-DC - 725 lbs. (329 kg)

AM-24-AC - 700 lbs. (318 kg)

AM-24-DC - 765 lbs. (347 kg)

AM-30-AC - 850 lbs. (386 kg)

AM-30-DC - 915 lbs. (415 kg)

AM-36-AC - 955 lbs. (433 kg)

AM-36-DC - 1,020 lbs. (463 kg)

- **Machine Height (Platform Lowered)**

AM19-AC – 6 ft. 5 in. (1.95 m)

AM19-DC – 6 ft. 5 in. (1.95 m)

AM24-AC – 6 ft. 5 in. (1.95 m)

AM24-DC – 6 ft. 5 in. (1.95 m)

AM30-AC – 7 ft. 7 in. (2.3 m)

* – 6 ft. 2 in. (1.88 m)

AM30-DC – 7 ft. 7 in. (2.3 m)

* – 6 ft. 2 in. (1.88 m)

AM36-AC – 8 ft. 11 in. (2.78 m)

* – 6 ft. 7 in. (2.0 m)

AM36-DC – 8 ft. 11 in. (2.78 m)

* – 6 ft. 7 in. (2.0 m)

* In tilt-back mode.

- **Maximum Platform Height**

AM19-AC – 19 ft. 6 in. (5.94 m)

AM19-DC – 19 ft. 6 in. (5.94 m)

AM24-AC – 24 ft. 0 in. (7.32 m)

AM24-DC – 24 ft. 0 in. (7.32 m)

AM30-AC – 30 ft. 0 in. (9.14 m)

AM30-DC – 30 ft. 0 in. (9.14 m)

AM36-AC – 36 ft. 0 in. (10.97 m)

AM36-DC – 36 ft. 0 in. (10.97 m)

- **Outrigger Footprint**

AM19 &

AM24 Models – 56 in. x 59 in.
(142 cm x 150 cm)

AM30 Models – 73 in. x 76 in.
(185 cm x 193 cm)

AM36 Models – 81 in. x 84 in.
(206 cm x 213 cm)

7-4. TORQUE REQUIREMENTS

When maintenance becomes necessary or a fastener has loosened, refer to the Torque Chart, Figure 7-1 to determine proper torque value.

7-5. LUBRICATION

Hydraulic Oil

Change the oil depending on the ambient temperatures prevailing in your area. Best performance can be obtained by utilizing ISO-Vg grade 32, 46 oil with a viscosity range between 150-250 SUS at 100 degrees F (32-54 cST at 40 degrees C). Minimum viscosity at operating temperature is 60 SUS (10cST). Maximum start-up viscosity at minimum ambient temperature is 4000 SUS (880 cST). Maximum recommended operating temperature of hydraulic oil is 150 degrees (65 degrees C).

Oils should be non-corrosive, have maximum anti-wear properties, rust and oxidation (treatment), and be non-foaming.

Recommended oils for an ambient temperature range of -10 degrees F to +100 degrees F (-23 degrees C to +38 degrees C) are as follows:

Table 7-1. Recommended Hydraulic Oils	
Amoco Oil Co.	Rycon Oil No. 32, 46 Amoco AW 32, 46
Cities Service Oil Co.	Citgo AW Hyd. Oil 32, 46 Citgo All Temp. Hyd. Oil
Chevron USA	Chevron EP Hyd. Oil 32, 46
Fina Oil Co.	Fina AW 32, 46 Fina Automatic Transmission Fluid Dexron II
Gulf Oil Corporation	Gulf Harmony 32 AW, 46 AW
Mobil Oil Corporation	DTE 15, 24, 25 Mobil Fluid # 300 Transmission Fluid
Sentinel Lubricants Corp.	Sentinel SH-10 Hydraulic Oil
Shell Oil Co.	Tellus Hyd. Oil 32, 46 Tellus "T" Hyd. Oil 32, 46
Texaco Inc.	Rando Oil Hd-32, 46
Union 76	XCel aw 46 (200)

Lubrication Specifications

Table 7-2. Lubrication Specifications	
KEY	SPECIFICATIONS
MPG	– Multipurpose Grease having a minimum dripping point of 350° F. Excellent water resistance and adhesive qualities, and being of extreme pressure type. (Timken OK 40 pounds minimum.)
EPGL	– Extreme Pressure Gear Lube (oil) meeting API service classification GL-5 or MIL-Spec MIL-L-2105.
HO	– Hydraulic Oil. ISO-Vg grade 32, 46.

7-6. PRESSURE ADJUSTMENT

Adjust system pressure so that platform will raise with rated capacity in platform. Do not adjust system pressure higher than required to raise the load. Make pressure adjustment with oil at normal operating temperature. If pressure is set when oil is cold, platform may not raise rated load after oil has warmed.

7-7. CYLINDER SPECIFICATIONS

Note

All dimensions are given in inches (in), with the metric equivalent, centimeters (cm), given in parentheses.

DESCRIPTION	BORE	STROKE	ROD DIA.
Lift Cylinder - AM19-AC & AM19-DC	1.50 (3.81)	54.50 (138.43)	1.125 (2.86)
Lift Cylinder - AM24-AC & AM24-DC	1.50 (3.81)	54.50 (138.43)	1.125 (2.86)
Lift Cylinder - AM30-AC & AM30-DC	1.50 (3.81)	69.00 (175.26)	1.125 (2.86)
Lift Cylinder - AM36-AC & AM36-DC	1.50 (3.81)	83.25 (211.46)	1.125 (2.86)

7-8. SERIAL NUMBER LOCATIONS

For machine identification, a serial number plate is affixed to the machine. The plate is located on the back of the mast, just above the mast support bracket. In addition, should the serial number plate be damaged or missing, the machine serial is stamped on the mast and on the base frame.

SIZE	THD	BOLT DIA. (IN)	TENSILE STRESS AREA (SQ. IN.)	SAE GRADE 5 BOLTS						SAE GRADE 8 BOLTS						RECOMMENDED TORQUE WRENCH SIZE		
				CLAMP LOAD (LB.)		TORQUE (LUB.) (LB. IN.)		(LOCTITE) LB. IN.	(DRY) LB. IN.	(LUB.) LB. IN.	(LOCTITE) LB. IN.	(DRY) LB. IN.	(LUB.) LB. IN.	(LOCTITE) LB. IN.	IN. OZS.	IN. LBS.	FT. LBS.	
				LB. IN.	LB. IN.	LB. IN.	LB. IN.											LB. IN.
4	40	0.1120	0.00604	380	8	6	—	—	—	540	12	9	—	—	160	10	—	
	48	0.1120	0.00661	420	9	7	—	—	—	600	13	10	—	—	160	10	—	
6	32	0.1380	0.00909	580	16	12	—	—	—	820	23	17	—	—	—	25	—	
	40	0.1380	0.01015	610	18	13	—	—	—	920	25	19	—	—	—	25	—	
8	32	0.1640	0.01400	900	30	22	—	—	—	1260	41	31	—	—	—	25	—	
	36	0.1640	0.01474	940	31	23	—	—	—	1320	43	32	—	—	—	25	—	
10	24	0.1900	0.01750	1120	43	32	—	—	—	1580	60	45	—	—	—	50	—	
	32	0.1900	0.02000	1285	49	36	—	—	—	1800	68	51	—	—	—	50	—	
1/4	20	0.2500	0.0318	2020	96	75	105	105	2860	144	108	—	—	—	—	100	—	
	28	0.2500	0.0364	2320	120	86	135	135	3280	168	120	—	—	—	—	200	—	
				LB. FT.	LB. FT.	LB. FT.	LB. FT.	LB. FT.	LB. FT.	LB. FT.	LB. FT.	LB. FT.	LB. FT.	LB. FT.	LB. FT.	LB. FT.	LB. FT.	
5/16	18	0.3125	0.0524	3340	17	13	19	19	4720	25	18	—	—	—	—	200	—	
	24	0.3125	0.0580	3700	19	14	21	21	5220	25	20	—	—	—	—	200	—	
3/8	16	0.3750	0.0775	4940	30	23	35	35	7000	45	35	—	—	—	—	300	25	
	24	0.3750	0.0878	5600	35	25	40	40	7900	50	35	—	—	—	—	300	50	
7/16	14	0.4375	0.1063	6800	50	35	55	55	9550	70	55	—	—	—	—	600	50	
	20	0.4375	0.1187	7550	55	40	60	60	10700	80	60	—	—	—	—	600	50	
1/2	13	0.5000	0.1419	9050	75	55	85	85	12750	110	80	—	—	—	—	1200	100	
	20	0.5000	0.1599	10700	90	65	100	100	14400	120	90	—	—	—	—	1200	100	
9/16	12	0.5625	0.2030	12950	110	80	120	120	16400	150	110	—	—	—	—	1200	100	
	18	0.5625	0.2260	14400	120	90	135	135	18250	170	130	—	—	—	—	1200	100	
5/8	11	0.6250	0.2560	16300	150	110	165	165	20350	220	170	—	—	—	—	1800	150	
	18	0.6250	0.2560	16300	170	130	190	190	23000	240	180	—	—	—	—	1800	150	
3/4	10	0.7500	0.3340	21300	260	200	285	285	30100	380	280	—	—	—	—	2400	200	
	16	0.7500	0.3730	23800	300	220	330	330	33600	420	320	—	—	—	—	2400	200	
7/8	9	0.8750	0.4620	29400	430	320	475	475	41600	600	460	—	—	—	—	3600	300	
	14	0.8750	0.5090	32400	470	350	520	520	45800	660	500	—	—	—	—	3600	300	
1	8	1.000	0.6060	38600	640	480	675	675	51500	900	680	—	—	—	—	7200	600	
	12	1.000	0.6630	42200	700	530	735	735	59700	1000	740	—	—	—	—	7200	600	
1-1/8	7	1.1250	0.7630	42300	800	600	840	840	68700	1280	960	—	—	—	—	7200	600	
	12	1.1250	0.8560	47500	880	660	925	925	77000	1440	1080	—	—	—	—	7200	600	
1-1/4	7	1.2500	0.9690	53800	1120	840	1175	1175	87200	1820	1360	—	—	—	—	Multi*	—	
	12	1.2500	1.0730	59600	1240	920	1300	1300	96600	2000	1500	—	—	—	—	Multi*	—	
1-3/8	6	1.3750	1.1550	64100	1460	1100	1525	1525	104000	2380	1780	—	—	—	—	—	—	
	12	1.3750	1.3150	73000	1680	1260	1750	1750	118100	2720	2040	—	—	—	—	—	—	
1-1/2	6	1.500	1.4050	78000	1940	1460	2025	2025	126500	3160	2360	—	—	—	—	Multi*	—	
	12	1.500	1.5800	87700	2200	1640	2300	2300	142200	3560	2660	—	—	—	—	Multi*	—	

Note: Tensile strength for bolt size 4 thru 1" – 120,000 (min. PSI), size 1-1/8" thru 1-1/2" – 105,000 (min. PSI).

* Torque Multiplier

Torque Specifications are usually given in foot-pounds; lower ranges in inch-pounds or inch-ounces.



SAE Grade 5



SAE Grade 8

Figure 7-1. Torque Chart.

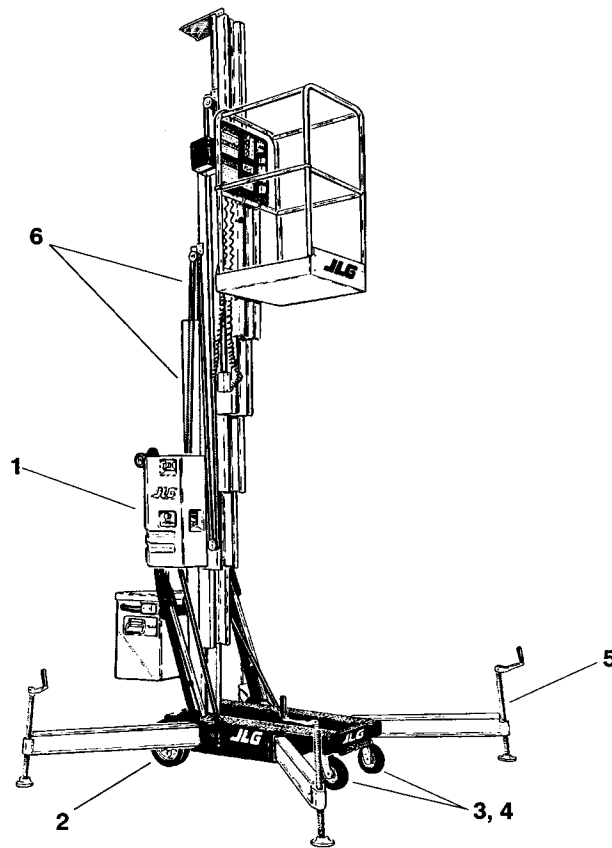

Figure 7-2. Lubrication Chart.

ITEM	COMPONENT	NO/TYPE LUBE POINTS	LUBE/METHOD	INTERVAL HOURS	COMMENTS
1	Hydraulic Oil	Breather Cap	HO - Check HO Level (See Note 4)	10	Check oil every 10 hrs.
			HO - Change HO	2000	Change oil every 2000 hrs.
2	Wheel Bearings	2 - Rear Wheels	MPG - Pressure Gun	500	
3	Caster Axles	2 - Front Casters	MPG - Brush	500	
4	Swivel Raceways	2 - Front Casters	MPG - Brush	500	
5	Leveling Jack Screws	4 - Jack Threads	MPG - Brush	500	
6	Mast Chains	2	Chain Lube - Brush or Spray	500	

Key To Lubricants: **MPG** - Multi-Purpose Grease
HO - Hydraulic Oil - See Table 7-1.

- Notes:
1. Be sure to lubricate like items on each side of machine.
 2. Recommended lubricating intervals are based on normal use. If machine is subjected to severe operating conditions, user must adjust lubricating requirements accordingly.
 3. Lubricating intervals are calculated on 50 hours of machine operation per week.
 4. Prior to checking hydraulic oil level, operate machine through one complete cycle of lift function (full up and down). Failure to do so will result in incorrect oil level reading on hydraulic reservoir.

8-1. GENERAL

This section provides general information to assist in the performance of maintenance on the personnel lift. Descriptions, techniques and specific procedures are designed to provide the safest and most efficient maintenance for use by personnel responsible for ensuring the correct installation and operation of machine components and systems.

CAUTION

WHEN AN ABNORMAL CONDITION IS NOTED AND PROCEDURES CONTAINED HEREIN DO NOT SPECIFICALLY RELATE TO THE NOTED IRREGULARITY, WORK SHOULD BE STOPPED AND TECHNICALLY QUALIFIED GUIDANCE OBTAINED BEFORE WORK IS RESUMED.

8-2. SERVICING AND MAINTENANCE GUIDELINES

• General

The following information is provided to assist you in the use and application of servicing and maintenance procedures contained in this chapter.

• Safety and Workmanship

Your safety, and that of others, is the first consideration when engaging in the maintenance of equipment. Always be conscious of component weight. Never attempt to move heavy parts without the aid of a mechanical device. Do not allow heavy objects to rest in an unstable position. When raising a portion of the equipment, ensure that adequate support is provided.

• Cleanliness

1. The most important single item in preserving the long service life of a machine is to keep dirt and foreign materials out of the vital components. Precautions have been taken to safeguard against this. Shields, covers, seals, and filters are provided to keep the wheel bearings, mast sections and oil supply clean; however, these items must be maintained on a scheduled basis in order to function properly.
2. At any time when oil lines are disconnected, clear adjacent areas as well as the openings and fittings themselves. As soon as a line or

component is disconnected, cap or cover all openings to prevent entry of foreign matter.

3. Clean and inspect all parts during servicing or maintenance, and assure that all passages and openings are unobstructed. Cover all parts to keep them clean. Be sure all parts are clean before they are installed. New parts should remain in their containers until they are ready to be used.

• Components Removal and Installation

1. Use adjustable lifting devices, whenever possible, if mechanical assistance is required. All slings (chains, cables, etc.) should be parallel to each other and as near perpendicular as possible to top of part being lifted.
2. Should it be necessary to remove a component on an angle, keep in mind that the capacity of an eyebolt or similar bracket lessens, as the angle between the supporting structure and the component becomes less than 90 degrees.
3. If a part resists removal, check to see whether all nuts, bolts, cables, brackets, wiring, etc., have been removed and that no adjacent parts are interfering.

• Component Disassembly and Reassembly

When disassembling or reassembling a component, complete the procedural steps in sequence. Do not partially disassemble or assemble one part, then start on another. Always recheck your work to assure that nothing has been overlooked. Do not make any adjustments, other than those recommended, without obtaining proper approval.

• Pressure-Fit Parts

When assembling pressure-fit parts, use an “anti-seize” or molybdenum disulfide base compound to lubricate the mating surface.

• Bearings

1. When a bearing is removed, cover it to keep out dirt and abrasives. Clean bearings in non-flammable cleaning solvent and allow to drip dry. Compressed air can be used but do not spin the bearing.

2. Discard bearings if the races and balls (or rollers) are pitted, scored, or burned.
3. If bearing is found to be serviceable, apply a light coat of oil and wrap it in clean (waxed) paper. Do not unwrap reusable or new bearings until they are ready to install.
4. Lubricate new or used serviceable bearings before installation. When pressing a bearing into a retainer or bore, apply pressure to the outer race. If the bearing is to be installed on a shaft, apply pressure to the inner race.

• Gaskets

Check that holes in gaskets align with openings in the mating parts. If it becomes necessary to hand-fabricate a gasket, use gasket material or stock of equivalent material and thickness. Be sure to cut holes in the right location, as blank gaskets can cause serious system damage.

• Bolt Usage and Torque Application

1. Use bolts of proper length. A bolt which is too long will bottom before the head is tight against its related part. If a bolt is too short, there will not be enough thread area to engage and hold the part properly. When replacing bolts, use only those having the same specifications of the original, or one which is equivalent.
2. Unless specific torque requirements are given within the text, standard torque values should be used on heat-treated bolts, studs, and steel nuts, in accordance with recommended shop practices. (See Figure 7-1.)

• Hydraulic Lines and Electrical Wiring

Clearly mark or tag hydraulic lines and electrical wiring, as well as their receptacles, when disconnecting or removing them from the unit. This will assure that they are correctly reinstalled.

• Hydraulic System

1. Keep the system clean. If evidence of metal or rubber particles is found in the hydraulic system, drain and flush the entire system.
2. Disassemble and reassemble parts on clean work surface. Clean all metal parts with non-flammable cleaning solvent. Lubricate components, as required, to aid assembly.

• Lubrication and Servicing

Components and assemblies requiring lubrication and servicing are shown in the Lubrication Chart, Figure 7-2. Service applicable components with the amount, type, and grade of lubricant recommended in this manual, at the specified intervals. When recommended lubricants are not available, consult your local supplier for an equivalent that meets or exceeds the specifications listed.

• Batteries

Clean batteries, using a non-metallic brush and a solution of baking soda and water. Rinse with clean water. After cleaning, thoroughly dry batteries and coat terminals with an anti-corrosion compound.

• Mast Chain Inspection Procedure

WARNING

MAST CHAINS TO BE INSPECTED AND LUBRICATED EVERY THREE MONTHS.

Inspect boom chains for the following conditions:

1. **Wear:** Always inspect that segment of chain that operates over a sheave. As the chain flexes over the extend/retract sheaves, joints and plate edges very gradually wear. Chain "stretch" can be measured using a manufacturer's wear scale or steel tape. When chains have elongated 3% they must be removed and replaced. Refer to Table 8-1 for proper chain specifications and allowable stretch tolerances. Peening and wear of chain plate edges are caused by sliding over a chain worn contact face of a sheave, or unusually heavy loads. All of the above require replacement of the chain and correction of the cause. Chain side wear, noticeable when pin heads and outside plates show a definite wear pattern, is caused by misalignment of the sheave/chain anchors and must be corrected promptly. Do not repair chains; if a section of chain is damaged, replace the entire chain set.
2. **Rust and Corrosion:** Rust and corrosion will cause a major reduction in the load carrying capacity of the chain, because these are primary reasons for side plate cracking. The initial

lubrication at the factory is applied in a hot dip tank to assure full penetration into the joint. Do not steam clean or degrease chains. At time of chain installation, factory lube must be supplemented by a maintenance program to provide a film of oil on the chains at all times. If chains are corroded, they must be inspected, especially the outside plates, for cracks in-line with the pins. If cracks are found, replace the chain; if no cracks are discovered, lubricate the chains by dipping in heated oil, and reinstall on the machine. Keep chains lubricated.

Chain Size	Pin to Pin Measurement	Allowable Stretch 12" Span
.50" Pitch	12" or 24 pitches	.36 in.

3. **Fatigue Cracks:** Fatigue is a phenomenon that affects most metals, and is the most common cause of chain plate failures. Fatigue cracks are found through the link holes, perpendicular (90 degrees) from the pin in-line position. Inspect chains carefully after long time use and heavy loading for this type of crack. If any cracks are discovered, replace all chains, as seemingly sound plates are on the verge of cracking. Fatigue and ultimate strength failures on JLG Lifts are incurred as a result of severe abuse as design specs are well within the rated lifting capacity of these chains.
4. **Tight Joints:** All joints in the roller chain should flex freely. On roller chain, tight joints are usually caused by rust/corrosion, or the inside plates "walking" off the bushing. Limber up rusty/corroded chains (after inspecting carefully) with a heavy application of oil (preferably a hot oil dip). Tap inside "walking" plates inward; if "walking" persists, replace the chain. This type of problem is accelerated by poor lubrication maintenance practice, and most tight joint chains have been operated with little or no lubrication. Tight joints on leaf chain are generally caused by:
 - a. Bent pins or plates.
 - b. Rusty joints.
 - c. Peened plate edges.

Oil rusty chains, and replace chains with bent or peened chain components. Keep chains lubricated.

5. **Protruding or Turned Pins:** Chains operating with inadequate lube generate tremendous friction between the pin and plates (pin and bushing on roller chain). In extreme cases, this frictional torque can actually turn the pins in the outside press-fit plates. Inspect for turned pins, which can be easily spotted as the "V" flats on the pin heads are no longer in line. Replace all chains showing evidence of turned or protruding pins. Keep chains lubricated.
6. **Chain Anchors and Sheaves:** An inspection of the chain must include a close examination of chain anchors and sheaves. Check chain anchors for wear breakage and misalignment. Anchors with worn or broken fingers should be replaced. They should also be adjusted to eliminate twisting the chain for an even load distribution.

Sheaves should be inspected for worn flanges, which would indicate misalignment, and wear on the outside diameter of the sheave. A worn sheave can mean several problems, as follows:

- a. Chains too tight.
- b. Sheave bearings/pin bad.
- c. Bent/misaligned chains.

• Mast Cable Inspection Procedure

⚠ IMPORTANT

MAST CABLES ARE TO BE INSPECTED EVERY THREE MONTHS.

⚠ CAUTION

WEAR PROTECTIVE GLOVES TO PROTECT HANDS WHEN HANDLING CABLE.

The periodic inspection shall cover the entire length of the cable. The inspection frequency shall be based on such factors as expected cable life as determined by experience on the particular application or similar installations, severity of environment, percentage of capacity lifts, frequency rates of operation, and exposure to shock loads. Inspection should be more frequent as cables approach the end of their useful lives.

Only the surface wires of the cable require inspection, do not attempt to open the cable. Any deterioration resulting in a appreciable loss of original strength, such as described below, shall be noted, and then a determination made if further use would

and then a determination made if further use would constitute a hazard.

No precise rules can be given for determination of the exact time for replacement of the cables. This depends largely on the good judgment of the qualified person evaluating the cable.

Conditions such as the following shall be sufficient reason for questioning continual use of the [cable] or increasing the frequency of inspection:

1. In running ropes, six randomly distributed broken wires in one lay or three broken wires in one strand in one lay.
2. One outer wire broken at the point of contact with the core of the rope which has worked its way out of the rope structure and protrudes or loops out from the rope structure. Additional inspection of this section is required.
3. Wear of one-third the original diameter of outside individual wires.
4. Kinking, crushing, birdcaging or any other damage resulting in distortion of the rope structure.
5. Evidence of any heat damage from any cause.
6. Reductions from nominal diameter of more than;
 - a. 1/64th in. (0.4mm) for diameters up to and including 5/16th in. (8.0mm);

Note

A good indicator of stretched extend/retract cables is if the adjusting nuts are bottomed out. If no adjustment remains the cables have stretched and need replacement.

Also check for cracked, bent, worn, severely corroded, or improperly installed cable ends.

Inspect sheave grooves for excessive wear.

8-3. LUBRICATION INFORMATION

• Hydraulic System

1. The primary enemy of a hydraulic system is contamination. Contaminants enter the system by various means, e.g., using inadequate hydraulic oil, allowing moisture, grease, filings, sealing components, sand, etc., to enter when performing maintenance, or by permitting the pump to cavitate due to insufficient system warm-up or leaks in the pump supply.
2. The design and manufacturing tolerances of the component working parts are very close, therefore, even the smallest amount of dirt or foreign matter entering a system can cause wear or damage to the components and generally results in faulty operation. Every precaution must be taken to keep hydraulic oil clean, including reserve oil in storage.
3. Cloudy oils indicate a high moisture content which permits organic growth, resulting in oxidation or corrosion. If this condition occurs, the system must be drained, flushed, and refilled with clean oil.
4. It is not advisable to mix oils of different brands or types, as they may not contain the same required additives or be of comparable viscosities. Good grade mineral oils, with viscosities suited to the ambient temperatures in which the machine is operating, are recommended for use.

Note

Metal particles may appear in the oil of new machines due to the wear-in of meshing components.

• Hydraulic Oil

For best performance, JLG recommends the use of ISO-Vg grade 32, 46 oil with a viscosity range between 15-250 SUS at 100 degrees F (32-54 cST at 40 degrees C). Refer to Section 7 for recommended hydraulic oils.

• Changing Hydraulic Oil

1. Use of any of the recommended hydraulic oils eliminates the need for changing the oil on a regular basis. If it is necessary to change the oil, use only those oils meeting or exceeding the specifications appearing in this manual. If

unable to obtain the same type of oil supplied with the machine, consult local supplier for assistance in selecting the proper equivalent. Avoid mixing petroleum and synthetic base oils. JLG Industries recommends changing the hydraulic oil annually.

2. Use every precaution to keep the hydraulic oil clean. If the oil must be poured from the original container into another, be sure to clean all possible contaminants from the service container.
3. While the unit is shut down, a good preventive maintenance measure is to make a thorough inspection of all hydraulic components, lines, fittings, etc., as well as a functional check of each system, before placing the machine back in service.

• Lubrication Specifications

Specified lubricants, as recommended by the component manufacturers, are always the best choice, however, multi-purpose greases usually have the qualities which meet a variety of single purpose grease requirements. Should any question arise regarding the use of greases in maintenance stock, consult your local supplier for evaluation. Refer to Table 7-2 for an explanation of the lubricant key designations appearing in the Lubrication Chart.

8-4. MAST ASSEMBLY AND DISASSEMBLY PROCEDURES

• Mast Disassembly Procedure

(See Figure 8-1.)

Note

Reference to mast sections -4/-5/-6 made following is dependent on which model machine you are servicing. The 24, 30 and 36 ft. models use six (6) mast sections whereas the 19 ft. mast assembly contains only 5 mast sections.

1. After the platform has been removed from the mast and mast has been removed from machine, lay mast assembly down with the shortest mast section-5/-6 on top and facing up.
2. Remove sequencing cables from sides of mast assembly. Also, remove the latch bar assembly from BOTTOM of mast section-5/-6.
3. Remove cable adjust nuts from threaded ends of cable attached to the cable anchor plate on BOTTOM end of mast section-5/-6 (*short, platform mounting section*). Push threaded ends of cable through anchor plate.
4. At TOP of mast section-5/-6, pull cables out and allow to hang loose.

Note

When sliding mast sections apart, be careful not to scratch or score the lubricating graphokote coating in the slide pad channels.

5. Carefully slide short mast section-5/-6 out BOTTOM of mast section-4/-5 rails. Disassemble slide pads, shims and cable anchor plate from mast section-5/-6, if necessary.

Note

Steps 6 through 10 apply to removal of mast section-5 used on 24, 30 & 36 ft. models which have six (6) mast sections. If servicing a 19 ft. mast, go to step 11.

6. Remove cable adjust nuts from threaded ends of cable attached to the cable anchor plate on bottom end of mast section-5. Push threaded ends of cable through anchor plate.
7. At top of mast section-5, pull cables out and allow to hang loose.
8. Slide mast section-5 out TOP of mast section-4 far enough to allow access to the cable sheave wheel assembly.

9. Remove countersunk-flathead screws securing cable sheave wheel assembly attach bars on both side rails at top of mast section-4/-5 and remove sheave wheel assembly.

Note

When sliding mast sections apart, be careful not to scratch or score the lubricating graphokote coating in the slide pad channels.

10. Carefully slide mast section-5 out BOTTOM of section-4. Remove slide pads, shims and cable anchor plate, if necessary.
11. Remove chain adjust nuts from threaded ends of chain attached to the chain anchor plate on BOTTOM end of mast section-4. Push threaded ends of cable through anchor plate.
12. At TOP of mast section-4, pull chains out and allow to hang loose, *(be certain floor surface is clean and free of any metal chips or debris which may stick to lubricated chains).*
13. Slide mast section-4 out TOP of mast section-3 far enough to allow access to the cable sheave wheel assembly.
14. Remove countersunk-flathead screws securing cable sheave wheel assembly attach bars on both side rails at TOP of mast section-4 and remove sheave wheel assembly.

Note

Step 15 applies only to 24, 30 & 36 ft. models which have six (6) mast sections. If servicing a 19 ft. mast, go to step 16.

15. While mast section-4 is still extended from section-3 remove the bolts attaching the two (2) cable assembly anchor eyelets to the TOP of mast section-4. Remove cables.

Note

When sliding mast sections apart, be careful not to scratch or score the lubricating graphokote coating in the slide pad channels.

16. Carefully slide mast section-4 out BOTTOM of section-3. Remove slide pads, shims and chain anchor plate, if necessary.
17. Remove chain adjust nuts from threaded ends of chain attached to the chain anchor plate on BOTTOM end of mast section-3. Push threaded ends of cable through anchor plate.
18. At TOP of mast section-3, pull chains out and allow to hang loose, *(be certain floor surface is*

clean and free of any metal chips or debris which may stick to lubricated chains).

19. Slide mast section-3 out TOP of mast section-2 far enough to allow access to the chain sheave wheel assembly.
20. Remove countersunk-flathead screws securing chain sheave wheel assembly attach bars on both side rails at TOP of mast section-3 and remove sheave wheel assembly.
21. While mast section-3 is still extended from section-2 remove the bolts attaching the two (2) cable assembly anchor eyelets to the TOP of mast section-3. Remove cables.

Note

When sliding mast sections apart, be careful not to scratch or score the lubricating graphokote coating in the slide pad channels.

22. Carefully slide mast section-3 out BOTTOM of section-2. Remove slide pads, shims and chain anchor plate, if necessary.
23. Slide mast section-2 out TOP of mast section-1 far enough to allow access to the chain assembly #444, anchor block/sheave wheel assembly.
24. Remove countersunk-flathead screws securing chain anchor block/sheave wheel assembly attach bars on both side rails at TOP of mast section-2.
25. Slide the chain anchor block/sheave wheel assembly and hydraulic cylinder out the TOP of mast section-2 far enough to allow removal of the sheave wheel attach bars, sheave wheels and sheave pin from chain assembly #444 anchor block.
26. Remove the setscrew holding the hydraulic cylinder rod into the chain assembly #444 anchor block. Lay chain assembly #444 to side.
27. Remove the hydraulic cylinder through BOTTOM of mast section-2, *be careful not to nick or score cylinder rod surface while removing.*

Note

When sliding mast sections apart, be careful not to scratch or score the lubricating graphokote coating in the slide pad channels.

28. Carefully slide mast section-2 out BOTTOM of section-1. Remove slide pads and shims, if necessary.

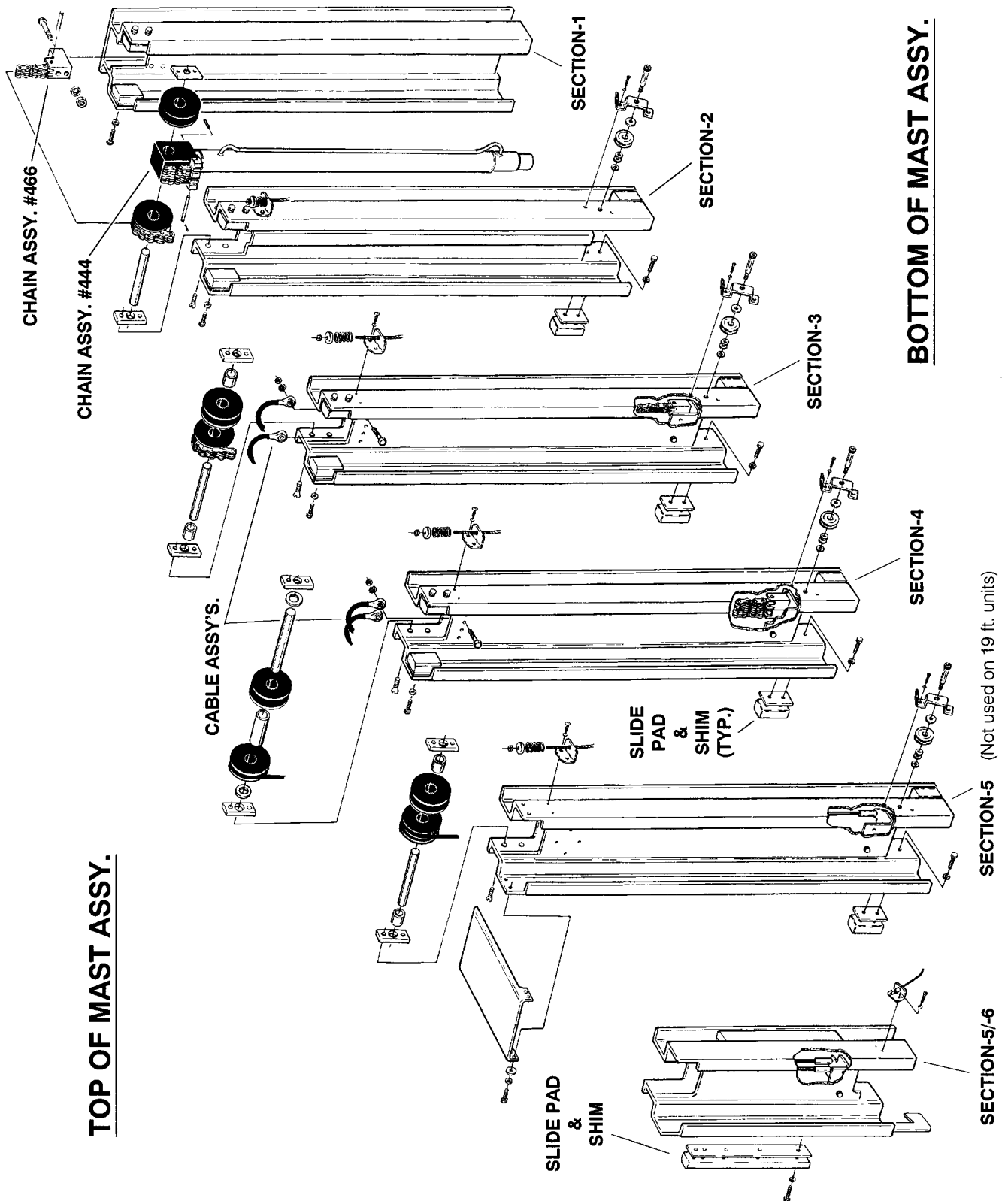

Figure 8-1. AccessMaster Mast Components.

29. Slide the TOP of remaining mast section-1 out over edge of work surface and remove the bolts attaching the anchor blocks of the two (2) #466 chain assemblies to mast section-1. Remove chain assemblies from mast and lay aside.
30. Remove slide pads and shims from mast section-1.

Mast disassembly should now be complete.

• Mast Assembly

(See Figure 8-1.)

1. Place mast section-1, rail (open) side up on a clean, flat surface (*preferably a table or work bench capable of supporting the weight of the entire mast assembly*). Slide mast out over end of work surface far enough to allow access to the chain anchor attach holes at top of mast.
2. Locate the two (2) single #466 (wide) chain assemblies. Lay out each chain assembly with anchor block end towards mast, and notched end of block down, (*be certain floor surface is clean and free of any metal chips or debris which may stick to lubricated chains*).
3. Insert the block anchor end (*with notched end on bottom*) into the top of mast section-1 and secure using two (2) 3/8"-16UNC x 2-1/2" long hex head bolts, flatwashers and nuts for each attach block. Place a flatwasher under bolt head and nut.

Note

When sliding mast sections together, be careful not to scratch or score the lubricating graphokote coating in the slide pad channels.

4. Locate mast section-2, carefully slide mast section-2 closed rail into section-1 open rail. Slide sections together until ends are even.

Note

Do not attach mast slide pads and shims to mast sections before assembling sections. If assembled in this manner, due to the tight fit of the slide pads in the slide pad channels, the lubricating graphokote coating could be removed from the receiving mast's slide pad channels.

5. Insert slide pads into the slide pad channels at bottom end of mast between section-1 and -2, (*one on each side of the mast*), with beveled surface facing out towards section-1.
6. Thread slide pad attaching bolts, (*two (2) 1/4"-*

20UNC x 3/8" long hex head bolts, place a flat washer under head of each bolt), through holes in mast section-2 inside rail, into the slide pad inserts. Thread in enough to hold pad in place.

7. Shim slide pads using the following steps:

Note

Always use the an even amount of shim material behind slide pads on both sides of the mast rails. This will keep mast sections centered in rail channels and prevent any distortion of the mast section.

- a. Use two shim pieces per slide pad, a thick one and a thin one.
- b. Start with a total thickness of approximately a .035" thick shim and a .075" thick shim.
- c. Slide shims into place between slide pad and mast rail, tap shims in place with plastic mallet, if necessary. Tighten the slide pad mounting bolts, be sure there are no air gaps between shims, shim and mast or shim and slide pad when tightened.
- d. Check mast section for side play. If play exists use thicker shims dividing thickness equally between both sides of mast.
- e. When mast slide pads are shimmed properly, there should be no side to side movement of slide pad in rail channel. Mast sections should be very snug in channels but still be able to slide in channel by hand.
8. Insert slide pads into the slide pad channels (*top of mast*) between section-1 and -2, (*one on each side of the mast*), with beveled surface facing in towards section-2.
9. Thread slide pad attaching bolts, (*two (2) 1/4"-20UNC x 3/8" long hex head bolts, place a flat washer under head of each bolt*), through holes in mast section-1 outside rail (*top of mast*) and into the slide pad inserts. Thread in enough to hold pad in place.
10. Shim per instructions in step 7.

Note

If hydraulic cylinder needs to be extended, the protective caps on the extend and return ports will need to be removed. Be careful not to nick or scour rod surface when extending, also catch any oil draining out of cylinder to avoid spillage onto work area.

11. Locate the hydraulic lift cylinder, slide the lift cylinder into the closed rail side of mast section-2 with rod end to top and port end to bottom

of mast. Cylinder should extend out of mast on both ends. Return tube should be on right side when facing bottom of mast assembly.

12. Locate chain assembly #444 (single anchor block with two narrow chains). Lay out chain assembly with anchor block end towards mast, (be certain floor surface is clean and free of any metal chip or debris which may stick to lubricated chains).
13. Insert hydraulic cylinder rod end into chain assembly #444, anchor block. Secure cylinder rod to anchor block with a 1/4"-28UNF x .50" long - Type C setscrew. Coat threads with blue Loctite # 242 before assembly.

Note

When sliding mast sections together, be careful not to scratch or score the graphokote coating in the slide pad rails.

14. Locate mast section-3, carefully slide section-3 closed rail into section-2 open rail. Slide sections together until ends are even.
15. Locate one (1) of the chain/cable anchor plates (one with threaded holes horizontally aligned to outside of bracket). Attach using outer set of holes in bottom of mast section-3 with two (2) 1/4"-20UNC x 3/4" long bolts, place a flat-washer under head of each bolt.
16. Slide mast section-3, approximately two feet out of the top of mast section-2.
17. Insert threaded ends of chain assembly #466 (attached to top of mast section-1), through holes in anchor plate attached to bottom of mast section-3. Loosely thread two (2) 3/8"-16UNC nuts onto stud threads on each chain. Chains will be adjusted later in assembly.
18. Slide mast section-2 out of mast section-1 approximately one foot.
19. Assemble chain sheaves on chain assembly #444 anchor block (attached to cylinder rod end) and attach to mast section-2 using following steps;
 - a. Insert sheave pin through anchor block on cylinder rod end.
 - b. Place sheave wheels (for wide chain) on sheave pin, one each side of anchor block.
 - c. On outside of each sheave wheel, place a sheave pin attach bar, (rectangular plate with threaded holes on each side of pin bore hole).

d. Slide the whole anchor block assembly with sheave pin, wheels and pin attach bars into top of mast section-2. (Position anchor block with narrow chains facing mast section-3).

e. Attach to top of mast section-2 using two (2) 3/8"-16UNC x 1/2" long socket head-countersunk-flathead cap screws each side. Coat threads with Loctite #171 and tighten.

20. Slide mast section-2 back into section-1 until end are even.

21. Locate two cable assemblies. Attach the eyelet anchor end of each cable to the outside holes near top of mast section-3 using 3/8"-16UNC x 1-1/4" long hex head bolts, nuts and flatwashers. Place a flatwasher under bolt head and nut.

Note

When sliding mast sections together, be careful not to scratch or score the lubricating graphokote coating in the slide pad channels.

22. Carefully slide mast section-3 into section-2 until ends are even. Check to make sure chain assembly #466 (wide chains) are seating properly in chain #444 anchor block chain sheave wheels attached to mast section-2.

Note

Do not attach mast slide pads and shims to mast sections before assembling sections. If assembled in this manner, due to the tight fit of the slide pads in the slide pad channels, the lubricating graphokote coating could be removed from the receiving mast's slide pad channels.

23. Insert slide pads into the top end mast rails between section-2 and -3, (one on each side of the mast), with beveled surface facing inward towards section-3.

24. Thread slide pad attaching bolts, (two (2) 1/4"-20UNC x 3/8" long hex head bolts, place a flat washer under head of each bolt), through holes in outside rail, on top of mast section-2 and into the slide pad inserts. Thread in enough to hold pad in place.

25. Shim per instructions in step 7.

26. Insert slide pads into the bottom end mast rails between section-2 and -3, (one on each side of the mast), with beveled surface facing out towards section-2.

27. Thread slide pad attaching bolts, (two (2) 1/4"-

20UNC x 3/8" long hex head bolts, place a flat washer under head of each bolt), through holes on inside rail, on bottom end of mast section-3 and into the slide pad inserts. Thread in enough to hold pad in place.

28. Shim per instructions in step 7.

Note

When sliding mast sections together, be careful not to scratch or score the graphokote coating in the slide pad channels.

29. Locate mast section-4, carefully slide section-4 closed rail into section-3 open rail. Slide sections together until ends are even.
30. Locate one (1) of the chain/cable anchor plates (one with two threaded holes vertically aligned in center of bracket). Attach through inner (vertical) set of holes at bottom of mast section-4 using two (2) 1/4"-20UNC x 3/4" long bolts, place a flatwashers under head of each bolt.
31. Slide mast section-4 out the top of mast section-3 so the chain/cable anchor plate on bottom of mast section-4 is easily accessible at top end of mast section-3. Rest the top end of mast section-4 on a support while performing next step.
32. Insert threaded ends of chain assembly #444 (attached to anchor block on top mast section-2) through the chain/cable anchor plate located on bottom of extended mast section-4. Loosely thread two (2) 3/8"-16UNC nuts onto stud threads on each chain. Chains will be adjusted later in assembly.

Note

When sliding mast sections together, be careful not to scratch or score the lubricating graphokote coating in the slide pad channels.

33. Slide mast section-4 back into mast section-3 except for about a foot or more. Allow enough slack in narrow chains to mount sheave wheels to top of mast section-3.
34. Extend mast section-3 out far enough from section-2 mast to gain access to top of section-3.
35. Assemble chain sheaves (for narrow chain assembly #444) to top of mast section-3 as follows;
- a. Locate the two (2) narrow chain sheave

wheels and slide onto sheave pin.

- b. Slide two (2) short spacer tubes onto sheave pin, one each end of sheave pin to outside of sheave wheels.
- c. Place two (2) sheave pin attach bars, one each end of sheave pin to outside of space tubes.
- d. Holding complete sheave wheel assembly, slide assembly into top of mast section-3 and align threaded holes in sheave pin attach bars with holes in mast rails.
- e. Attach to top of mast section-3 using two (2) 3/8"-16UNC x 1/2" long socket head-countersunk-flathead cap screws, each side. Coat threads with Loctite #171 and tighten.

Note

When sliding mast sections together, be careful not to scratch or score the lubricating graphokote coating in the slide pad channels.

36. Slide mast section-3 back into section-2 until ends are even. (Mast section-2 may need to be restrained to keep its slide pads from pushing out the bottom of mast section-1).

The following step 37 applies only to 24, 30 and 36 ft. masts. These masts contain one mast section more than the 19 ft. mast. If assembling a 19 ft. mast jump to step 38.

37. While mast section-4 is still extended from section-3; locate two cable assemblies. Attach the eyelet anchor end of each cable to the inside set of holes near top of mast section-4 using 3/8"-16UNC x 1-1/4" long hex head bolts, nuts and flatwashers. Place a flatwasher under bolt head and nut.
38. While mast section-4 is still extended from section-3, assemble cable sheaves to top of mast section-4 as follows;
- a. Locate the wide tube spacer and slide onto sheave pin.
- b. Slide two (2) cable sheave wheels onto sheave pin, one each end of sheave pin to outside of tube spacer.
- c. Place two (2) large flat washers, one each end of sheave pin to outside of cable sheave wheels.
- d. Place two (2) sheave pin attach bars, one each end of sheave pin to outside of large flatwashers.

- e. Holding complete cable sheave wheel assembly, slide assembly into top of mast section-4 and align threaded holes in sheave pin attach bars with holes in mast rails.
- f. Attach to top of mast section-4 using two (2) 3/8"-16UNC x 1/2" long socket head-countersunk-flathead cap screws, each side. Coat threads with Loctite #171 and tighten.

Note

When sliding mast sections together, be careful not to scratch or score the lubricating graphokote coating in the slide pad channels.

- 39. Carefully slide mast section-4 back into section-3 until ends are even. Check to make sure chain assembly #444 (narrow chains) are seating properly in chain sheave wheels attached to top of mast section-3.

Note

Do not attach mast slide pads and shims to mast sections before assembling sections. If assembled in this manner, due to the tight fit of the slide pads in the slide pad rails, the lubricating graphokote coating could be removed from the receiving mast's slide pad channels.

- 40. Insert slide pads into the top end mast rails between section-3 and -4, (*one on each side of the mast*), with beveled surface facing inward towards section-4.
- 41. Thread slide pad attaching bolts, (*two (2) 1/4"-20UNC x 3/8" long hex head bolts, place a flat washer under head of each bolt*), through holes in outside rail, on top of mast section-3 and into the slide pad inserts. Thread in enough to hold pad in place.
- 42. Shim per instructions in step 7.
- 43. Insert slide pads into the bottom end mast rails between section-3 and -4, (*one on each side of the mast*), with beveled surface facing out towards section-3.
- 44. Thread slide pad attaching bolts, (*two (2) 1/4"-20UNC x 3/8" long hex head bolts, place a flat washer under head of each bolt*), through holes on inside rail, on bottom end of mast section-4 and into the slide pad inserts. Thread in enough to hold pad in place.
- 45. Shim per instructions in step 7.

The following steps 46 through 55 apply to 24, 30 and 36 ft. masts only. These masts contain one mast section more than a 19 ft. mast. If assembling a 19 ft. mast jump to step 56.

Note

When sliding mast sections together, be careful not to scratch or score the lubricating graphokote coating in the slide pad channels.

- 46. Locate mast section-5, carefully slide section-5 closed rail into section-4 open rail. Slide sections together until ends are even.
- 47. Locate one (1) of the chain/cable anchor plates (*one with threaded holes horizontally aligned to outside edges of bracket*). Attach through outer set of holes in bottom of mast section-5 with two (2) 1/4"-20UNC x 3/4" long bolts, place a flatwasher under head of each bolt.
- 48. Slide mast section-5 out the top of mast section-4 so the chain/cable anchor plate on bottom of mast section-5 is easily accessible at top end of mast section-4. Rest the top end of mast section-5 on a support while performing next step.
- 49. Insert threaded ends of cable assembly (*attached to top of mast section-3*) through the chain/cable anchor plate located on bottom of extended mast section-5. Loosely thread two (2) 3/8"-16UNC nuts onto stud threads on each chain. Chains will be adjusted later in assembly.

Note

When sliding mast sections together, be careful not to scratch or score the lubricating graphokote coating in the slide pad channels.

- 50. Slide mast section-5 back into section-4 except for a foot or two of length to allow slack in.
- 51. Extend mast section-4 out far enough from section-3 mast to gain access to top of section-4.
- 52. Locate two cable assemblies. Attach the eyelet anchor end of each cable to the two inside holes near top of mast section-4 using 3/8"-16UNC x 1-1/4" long hex head bolts, nuts and flatwashers. Place a flatwasher under bolt head and nut.
- 53. Carefully slide mast section-4 back into section-3 until ends are even. Check to make sure chain assembly #444 (narrow chains) are seating properly in chain sheave wheels attached

to top of mast section-3. (Mast sections-2 and -3 may need to be restrained to keep their slide pads from pushing out the bottom of mast sections-1 and -2).

54. While mast section-5 is still extended from section-4, assemble cable sheaves to top of mast section-5 as follows;
- Locate remaining sheave pin. Slide two (2) cable sheave wheels onto sheave pin and center.
 - Place two (2) short spacer tubes on sheave pin, one on each end of sheave pin to outside of sheave wheels.
 - Place two (2) sheave pin attach bars, one on each end of sheave pin to outside of short spacer tubes.
 - Holding complete cable sheave wheel assembly, slide assembly into top of mast section-5 and align threaded holes in sheave pin attach bars with holes in mast rails.
 - Attach to top of mast section-5 using two (2) 3/8"-16UNC x 1/2" long socket head-countersunk-flathead cap screws, each side. Coat threads with Loctite #171 and tighten.

Note

When sliding mast sections together, be careful not to scratch or score the lubricating graphokote coating in the slide pad channels.

55. Carefully slide mast section-5 back into section-4 until ends are even. Check to make sure cable set from top of section-3 is seating properly in cable sheave wheels attached to top of mast section-4. (Mast sections-2, -3 and -4 may need to be restrained to keep their slide pads from pushing out the bottom of mast sections-1, -2 and -3).

Note

The platform mounting section (section-5 on 19 ft. machines and section-6 on 24, 30 and 36 ft. machines) slide pads, are assembled differently than the slide pads for the other mast sections. Mast section-5/-6 slide pads may need to be assembled/disassembled several times in order to determine the correct shim stock required for proper fit.

56. Locate the remaining mast section-5/-6 (platform mounting- mast section). Lay mast section on flat stable surface.

57. Attach the remaining chain/cable anchor plate (one with threaded holes vertically aligned in center of bracket). Attach through inner (vertical) set of holes in bottom of mast section-5/-6 with two (2) 1/4"-20UNC x 3/4" long bolts, place a flatwasher under head of each bolt.

58. Complete the following steps to determine shim stock thickness required for section-5/-6;

Note

Always use the an even amount of shim material behind slide pads on both sides of the mast rails. This will keep mast sections centered in rail channels and prevent any distortion of the section.

- Use two shim pieces per slide pad, a thick one and a thin one.
- Start with a total thickness of approximately .035" and .075" thick shim stock.

Note

To protect the lubricating graphokote coating when sliding the assembled mast section-5/-6 into section-4/-5, grind top and bottom edges of slide pads to approximately a 1/4" radius.

- Attach shim stock and slide pads to both sides of mast section-5/-6 using five (5) 1/4"-20UNC x 1-1/4" long, hex head cap screws per side, with flatwasher under each bolt head. (Assemble shim stock and slide pad to mast section rail with shim stock against rail and slide pad with beveled side out).
- Carefully thread the slide pad mounting bolts with flatwashers through slide pads and shim stock into threads in mast section-5/-6. Be certain there are no air gaps between shims, shim and mast or shim and slide pad when tightened.

Note

When sliding mast section-5/-6 into section-4/-5 note amount of force required to push sections together. Fit should be very snug but still be able to be pushed together by hand. If too tight, remove section-5/-6, disassemble slide pad from section-5/-6 and reduce thickness of shim stock.

- Begin sliding top of mast section-5/-6 with closed rail down engaging the slide pads into slide pad channels at bottom of mast section-4/-5's open rail. Continue to push section-5/-6 into section-4/-5 until BOTTOM ends of mast sections are even.

- f. Check mast section for side play. If play exists use thicker shims dividing thickness equally between both sides of mast.
 - g. When mast slide pads are shimmed properly, there should be no side to side movement of slide pad in rail channel. Mast sections should be very snug in channels but still be able to slide in channel by hand.
59. Slide mast section-5/-6 to top of section-4/-5.
 60. Insert threaded ends of cable assembly (*attached to top of mast section-4*) through the chain/cable anchor plate located on bottom of extended mast section-5/-6. Loosely thread two (2) 3/8"-16UNC nuts onto stud threads on each chain. Chains will be adjusted later in assembly.
 61. Slide mast section-5/-6 back into mast section-4/-5 until bottom ends of masts are even. Check to make sure cable set attached to top of section-3/-4 is seating properly in cable sheave wheels attached to top of mast section-4/-5. (*Mast sections-2, -3 and -4/-5 may need to be restrained to keep their slide pads from pushing out the bottom of mast sections-1, -2 and -3/-4*).
 62. At bottom of mast assembly, thread all chain/cable adjusting nuts on threaded ends until they are snug against the anchor plates and all slack is removed from chains and cables. Check that chains and cables are seated in their sheave wheels at top of mast assembly. Also, ends of mast sections should be even with each other.
- Mast assembly should now be complete.**

8-5. MAST TO BASE FRAME INSTALLATION

1. Using an overhead crane or suitable lifting device capable of supporting the weight of base frame, attach a sling strap or chain to the front crossmember of the base frame, raise base frame.
2. Extend hydraulic cylinder out from bottom of mast assembly approximately one (1) foot. (*Caps on extend and return ports will need to be removed to extend cylinder. Catch any hydraulic fluid expelled from return port in a container to prevent spillage onto work area*).
3. Bring base frame into position in front of mast assembly, (*base frame and mast assembly must be held at 90° angle to each other*).
4. Slide port end of hydraulic cylinder through hole in base frame cylinder mounting channel. (*Return port (tube side) of cylinder must be on right side facing bottom of base and mast*).
5. Align threaded hole in side of hydraulic cylinder head with hole in tab on bottom side of cylinder mounting channel. Secure hydraulic cylinder to cylinder mounting channel tab using a 5/16"-18UNC x 5/8" long hex head bolt and flat washer.
6. Carefully push mast assembly and base assembly together until the four (4) holes on bottom rear of mast align with holes in the base frame mast support crossmember.
7. Attach mast to base using four (4) 3/8"-16UNC x 1" long hex head bolts, locknuts and flatwashers, (*place a flatwasher under bolt head and nut and mount with nuts on inside of frame*).
8. Locate the two (2) mast support braces, attach to sides of base frame using a 3/8"-16UNC x 1" long hex head bolt, nut and flatwashers each brace, (*place a flatwasher under bolt head and nut and mount with nuts on inside of frame. Use access hole in bottom of frame to attach nut inside frame*).
9. Before setting machine upright on base, install a short 90° elbow fitting, flow control valve and another short 90° elbow fitting on the end of the flow control valve in the extend (*left*) port on bottom of hydraulic cylinder. Install a long 90° elbow fitting on return (*right*) port. Use sealant tape on fitting threads. Cap ports until hydraulic lines are installed.
10. Carefully set machine in an upright position on its base frame wheels.
11. Locate the mast support bracket. Attach mast support bracket to mounting holes halfway up back of mast using four (4) 3/8"-16UNC x 2-3/4" long hex head bolts, locknuts and flatwashers. (*Place a flatwasher under bolt head and nut and mount with nuts on inside of frame*).
12. Using a 4 ft. level, ensure mast is set to vertical (*plumb*) on the base frame.
13. When mast is vertical (*plumb*), attach support braces, (*bolted to base*), to the mast support bracket, (*bolted to mast*), using 3/8"-16UNC x

2-3/4" long hex head bolts, nuts and flatwashers. (Place a flatwasher under bolt head and nut and mount with nuts on inside of bracket).

14. After securing mast to base frame, using 4 ft. level again check that mast is vertical (*plumb*) on base frame.

Mast installation should now be complete.

8-6. MAST CHAINS/CABLES AND SEQUENCING CABLES ADJUSTMENT

• Mast Chain/Cable Adjustment

Note

Refer to Figure 8-2 for mast chain/cable routing.

1. Elevate platform until chain anchor studs are accessible from the bottom of each mast section.
2. Loosen bottom locknut and tighten top nut until chain is just tight.
3. Tighten bottom locknut until it is locked tight against top nut. Chain should have slight tension but should not be taut.
4. Repeat steps (2) and (3) for remaining mast sections. ENSURE THAT ALL CHAINS HAVE EQUAL TENSION.

• Sequencing Cable Adjustment

1. Check each sequencing cable on outside of masts for excessive slack. Adjust only to remove slack from cable.
2. Tighten nylon locknut just enough to remove excessive slack from sequencing cable. DO NOT overtighten cable.

8-7. PREVENTIVE MAINTENANCE AND INSPECTION SCHEDULE

(See Table 8-2.)

The preventive maintenance and inspection checks are listed and defined in the following table (See Table 8-2., *this chapter*). This table is divided into two basic parts, the "AREA" to be inspected and the "INTERVAL" at which the inspection is to take place. Under the "AREA" portion of the table, the various systems along with the components that make up that system are listed. The "INTERVAL" portion of the table is divided into five columns representing the various inspection time periods. The numbers listed within the interval column represent the applicable inspection code for which that component is to be checked.

The checks and services listed in this schedule are not intended to replace any local or regional regulations that may pertain to this type of equipment nor should the lists be considered as all inclusive. Variances in interval times may occur due to climate and/or conditions and depending on the location and use of the machine.

JLG Industries requires that a complete annual inspection be performed in accordance with the "Annual Machine Inspection Report" form. Forms are supplied with each new machine and are also available from JLG Customer Service. Form must be completed and returned to JLG Industries.

IMPORTANT

JLG INDUSTRIES REQUIRES THAT A COMPLETE ANNUAL INSPECTION BE PERFORMED IN ACCORDANCE WITH THE "ANNUAL MACHINE INSPECTION REPORT" FORM.

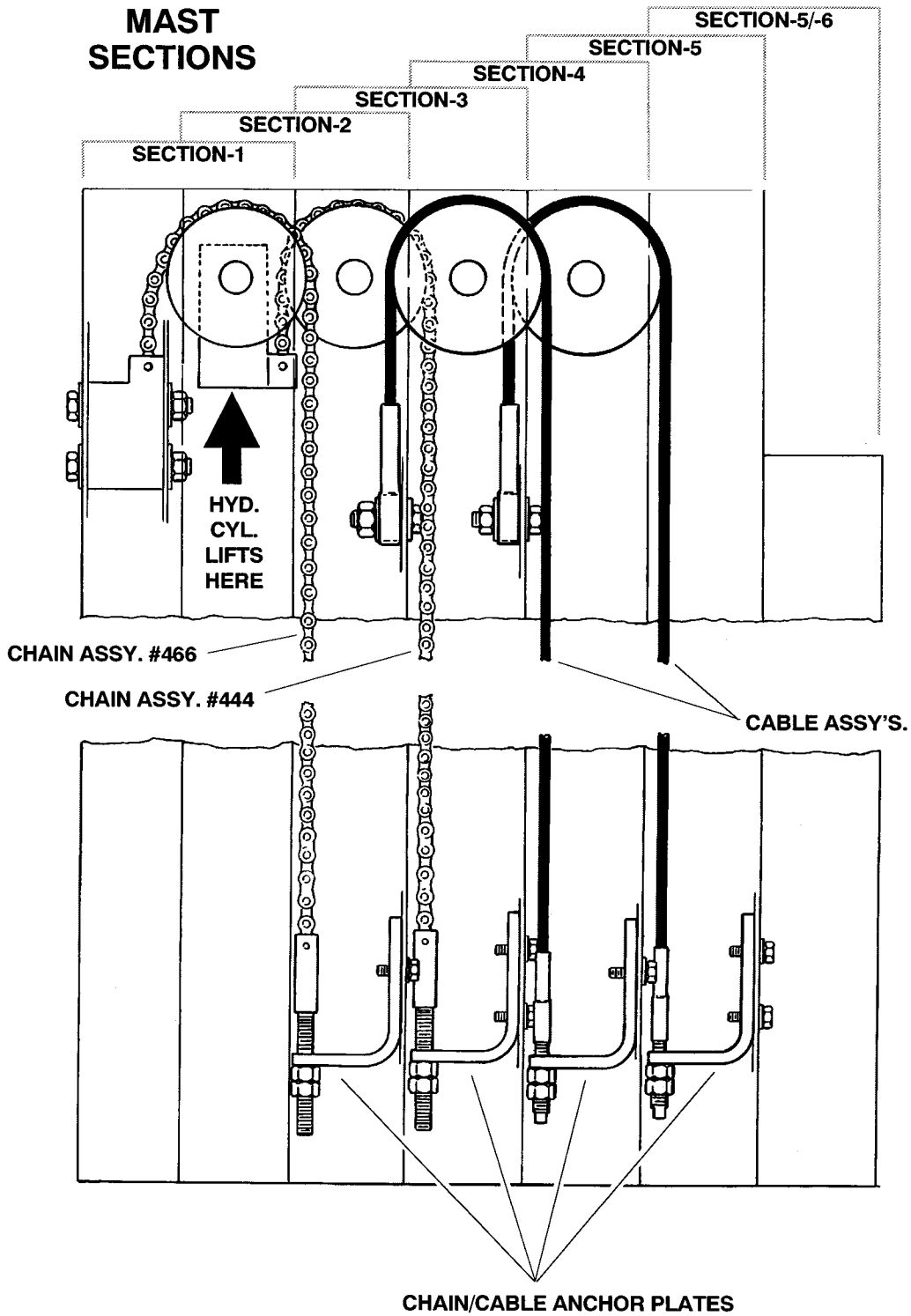

Figure 8-2. Mast Chain/Cable Routing Diagram.

**Table 8-2.
PREVENTIVE MAINTENANCE AND INSPECTION SCHEDULE**

AREA	INTERVAL				
	(10 HRS) DAILY	(50 HRS) WEEKLY	(200 HRS) MONTHLY	(500 HRS) 3 MONTH	(1000 HRS) 6 MONTH
PLATFORM					
1. Control Switches	1,11				
2. Placards and Decals	1,2				
3. Control Tags	1,2				
4. Electrical Cables	1,8				
5. Handrail and Bar Gate	1,4				
MAST					
1. Mast Chains/Cables	1,4,7,9			12	
2. Mast Sections	1,4,7				
3. Mast Sequencing Cables	1,7,9				
BASE FRAME					
1. Batteries (DC Models)	1,3	5			
2. Battery Charger (DC Models)	1				
3. Power Cable (AC Models)	1,8				
5. Electric Motor/Hydraulic Pump Unit	1	5			
6. Hydraulic Flow Control Valve	1	5			
7. Hydraulic Hoses and Fittings	1	5			
8. Hydraulic Oil Reservoir *	3	5	4		
9. Hydraulic Oil Reservoir Breather		6,14			
10. Manual Descent Knob	1,7				
11. Lift Cylinder	1	5,6,13	4		
12. Outrigger Beam/Outrigger Socket Interlock Contacts	1,9				
13. Outrigger Lock Pins	1,4		7,8		
14. Leveling Jacks	1,6,7,8			12	
15. Placards and Decals	1,2				
16. Wheels and Casters	1	8,9		12	
17. Wheel Bearings			8	12	
18. Power Switch, Ground Control	1,11				
19. Control Tags	1,2				
20. Placards and Decals	1,2				
21. Hoses and Cables	1,8				

* Inspection and Maintenance Code 10 to be performed annually.

The inspection and maintenance code numbers are as follows:

1. Check for proper and secure installation.
2. Check for visible damage and legibility.
3. Check for proper fluid level.
4. Check for any structural damage; cracked or broken welds; bent or warped surfaces.
5. Check for leakage.
6. Check for presence of excessive dirt or foreign material.
7. Check for proper operation and freedom of movement.
8. Check for excessive wear or damage.
9. Check for proper tightness and adjustment.
10. Drain, clean and refill.
11. Check for proper operation while pump/motor is running.
12. Check for proper lubrication.
13. Check for evidence of scratches, nicks or rust and for straightness of rod.
14. Check for condition of element; replace as necessary.

9-1. GENERAL

This section contains troubleshooting information to be used for locating and correcting most of the operating problems which may develop in the aerial platform. If a problem should develop which is not presented in this section or which is not corrected by listed corrective actions, technically qualified guidance should be obtained before proceeding with any maintenance.

9-2. TROUBLESHOOTING INFORMATION

The troubleshooting procedures applicable to the aerial platform are listed and defined in Tables 9-1, AC Unit Troubleshooting and 9-2, DC Unit Troubleshooting.

Each malfunction within an individual group or system is followed by a listing of probable causes which will enable determination of the applicable remedial action. The probable causes and the remedial action should, where possible, be checked in the order listed in the tables.

It should be noted that there is no substitute for a thorough knowledge of the equipment and related systems.

It should be recognized that the majority of the problems arising in the machine will be centered in the hydraulic and electrical systems. For this reason, every effort has been made to ensure that all likely problems in these areas are given the fullest possible treatment. In the remaining machine groups, only those problems which are symptomatic of greater problems which have more than one probable cause and remedy are included. This means that problems for which the probable cause and remedy may be immediately obvious are not listed in this section.

The first rule for troubleshooting any circuit that is hydraulically operated and electrically controlled is to determine if the circuit is lacking hydraulic oil and electrical control power. This can be ascertained by overriding the bypass valve (mechanically or electrically) so that oil is available to the function valve, then overriding the function valve mechanically. If the function performs satisfactorily, the problem exists with the control circuit.

9-3. HYDRAULIC CIRCUIT CHECKS

(See Figure 9-2.)

The first reference for improper function of a hydraulic system, where the cause is not immediately apparent, should be the Troubleshooting Chart. The best place to begin the problem analysis is at the power source (pump). Once it is determined that the pump is serviceable, then a systematic check of the circuit components, beginning with the control, would follow.

Note

For aid in Hydraulic troubleshooting, refer to Figure 9-2. Hydraulic Diagram at the end of this section. Refer to the Illustrated parts list Section 10-7. for ELECTRICAL DIAGRAMS of the various circuits.

9-4. OUTRIGGER INTERLOCK CONTACTS

- **Outrigger Socket and Outrigger Beam - Interlock Contacts**

It is very important that the outrigger interlock contactor heads (*round*) on the bottom of the outrigger sockets of the base frame and the contactor plate on the bottom of each outrigger beam are installed properly, (see Figure 9-1. for correct installation). Also see Troubleshooting Tables 9-1. & 9-2. for any further reference to possible problems with interlock contacts.

- **Outrigger Socket - Contactor Screw Tightening Instructions**

(See Figure 9-1.)

1. Install insulating grommets into holes (*on the bottom*) inside of outrigger sockets in base frame.
2. Assemble two (2) #8-32UNC x 5/8" long contactor screws with two (2) #8 nylon washers under head and insert screw through insulating grommet as shown in Figure 9-1.
3. Install one (1) #8 nylon washer onto contactor screw threads against insulating grommet.
4. Apply Loctite #242 to screw threads.
5. Install one (1) standard #8 brass nut and thread in against nylon washer until insulating grommet just starts to compress. If necessary tighten nut further until top of contactor screw head measures 0.212" off floor of outrigger socket. (See Figure 9-1.)

Table 9-1.
A.C. UNIT – TROUBLESHOOTING

TROUBLESHOOTING CHART

TROUBLE	PROBABLE CAUSE	REMEDY
Outrigger LED light does not turn on.		
	Outriggers are not properly inserted in outrigger sockets. Power source is OFF. Fuse(s) blown. Check for loose wire(s) on contactor screws under outrigger sockets (causing an open circuit). Contactor damaged. LED burnt out. Pull pin on outrigger socket is damaged.	Check all outriggers for proper installation in outrigger sockets. Check power source. Check all insulating grommets on interlock contactors in base frame outrigger sockets and contactor plates on outrigger beams. Replace damaged grommet(s) and replace blown fuse. Properly reinstall wire to contactor screw per Figure 9-1. and instructions in Section 9-4. "Outrigger Interlock Contacts". Replace contactor. Replace LED. Replace pull pin.
Unit does not rise when the four LED's are ON and motor does not start.		
	Red emergency button is engaged (PUSHED IN) on either ground control station or on platform. Control relay not functioning. Motor start relay not functioning. Unit wiring not properly grounded.	Disengage (TURN CLOCKWISE) red emergency button until it pops out. Replace control relay. Replace motor start relay. Check all grounds in the wiring.
Unit lowers by itself.		
	Manual descent valve open. Hydraulic hose and/or fittings loose causing a hydraulic pressure leak. Lift DOWN solenoid valve not functioning.	Close manual descent valve. Tighten hydraulic hose and/or fittings. Replace Lift DOWN solenoid valve.
Unit leaking hydraulic oil.		
	Hydraulic hose and/or fittings loose. Valve and/or plug loose. Breather cap on tank is saturated or clogged with oil. Hydraulic oil tank over-filled.	Tighten hydraulic hose and/or fittings. Tighten valve and/or plug. Replace breather cap on tank. Lower oil level to full mark on dipstick.
Unit lowers very slowly.		
	Flow control valve not functioning.	Replace flow control valve.
Unit makes noise while raising and lowering.		
	Mast sections need lubrication.	Spray graphokote in mast slide pad rails with silicone lubricant.

**Table 9-2.
D.C. UNIT – TROUBLESHOOTING**

TROUBLESHOOTING CHART		
TROUBLE	PROBABLE CAUSE	REMEDY
Outrigger LED light does not turn on.		
	Outriggers are not properly inserted in outrigger sockets. Power source is OFF. Fuse(s) blown. Check for loose wire(s) on contactor screws under outrigger sockets (causing an open circuit). Contactor damaged. LED burnt out. Pull pin on outrigger socket is damaged.	Check all outriggers for proper installation in outrigger sockets. Check power source. Check all insulating grommets on interlock contactors in base frame outrigger sockets and contactor plates on outrigger beams. Replace damaged grommet(s) and replace blown fuse. Properly reinstall wire to contactor screw per Figure 9-1. and instructions in Section 9-4. "Outrigger Interlock Contacts". Replace contactor. Replace LED. Replace pull pin.
Unit does not rise when the four LED's are ON and motor does not start.		
	Red emergency button is engaged (PUSHED IN) on either ground control station or on platform. Control relay not functioning. Motor start relay not functioning. Unit wiring not properly grounded.	Disengage (TURN CLOCKWISE) red emergency button until it pops out. Replace control relay. Replace motor start relay. Check all grounds in the wiring.
Unit lowers by itself.		
	Manual descent valve open. Hydraulic hose and/or fittings loose causing a hydraulic pressure leak. Lift DOWN solenoid valve not functioning.	Close manual descent valve. Tighten hydraulic hose and/or fittings. Replace Lift DOWN solenoid valve.
Unit leaking hydraulic oil.		
	Hydraulic hose and/or fittings loose. Valve and/or plug loose. Breather cap on tank is saturated or clogged with oil. Hydraulic oil tank over-filled.	Tighten hydraulic hose and/or fittings. Tighten valve and/or plug. Replace breather cap on tank. Lower oil level to full mark on dipstick.
Unit lowers very slowly.		
	Flow control valve not functioning.	Replace flow control valve.
Unit makes noise while raising and lowering.		
	Mast sections need lubrication.	Spray graphokote in mast slide pad rails with silicone lubricant.

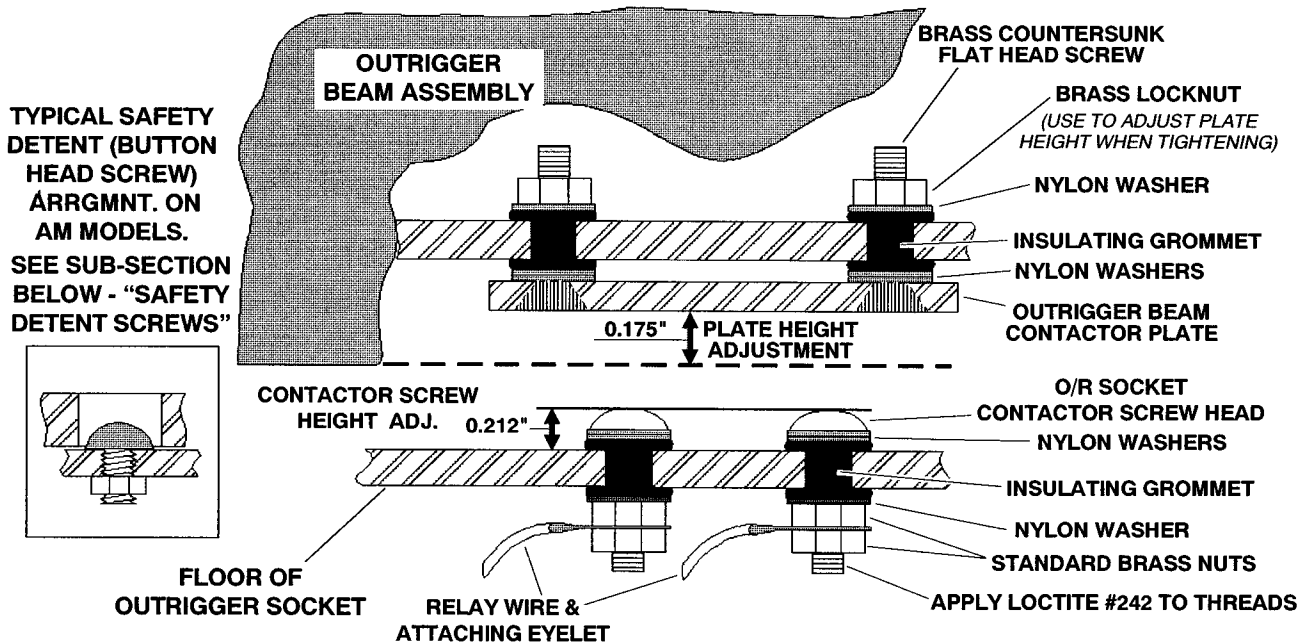

Figure 9-1. Base Frame Outrigger Socket Contactor Heads and Outrigger Beam Contactor Plate.

6. Install wire end eyelet onto threaded end against previously installed brass nut.
7. Install second standard brass nut and thread tight against wire end eyelet.
8. While holding first brass nut, jam (tighten) second brass nut against wire end eyelet.

• Outrigger Beam - Interlock Contactor Plate Mounting Instructions

(See Figure 9-1.)

1. Assemble insulating grommets into holes in outrigger beam.
2. Locate contactor plate and insert two (2) brass #8 - 32UNC x 3/4" long countersunk flathead screws through the contactor plate and install two (2) nylon washers on each screw against contactor plate.
3. On outside of outrigger beam slide threads of brass screws (of contactor plate assembly) through insulating grommets in outrigger beams until nylon washers rest against grommets and hold in place if necessary.
4. Install one (1) nylon washer on each screw inside of outrigger beam, against insulating grommet.

5. Thread a brass #8 - 32UNC locknut onto each screw inside outrigger beam, tighten screws until .175" height exists between bottom of plate and bottom most edge of outrigger beam (See Figure 9-1.).

• Safety Detent Screws

(See Figure 9-1.)

OUTRIGGER BEAMS are manufactured with a series of holes drilled around the CONTACTOR PLATE assembly.

OUTRIGGER SOCKETS are equipped with button head screws (*safety detent screws*) mounted around the CONTACTOR SCREW HEADS on the floor of the outrigger socket. The safety detent screws must align with the holes in the outrigger socket before the contactor plate on the outrigger beam, and the contactor screw heads in the bottom of the outrigger socket can make contact to complete the interlock circuit.

The purpose of this configuration is to assure the proper outrigger beams are used with their specific models to assure machine stability, i.e. the shorter outrigger beams of the AM-19 and AM-24 models cannot be mistakenly used on higher reaching AM-30 or AM-36 models.

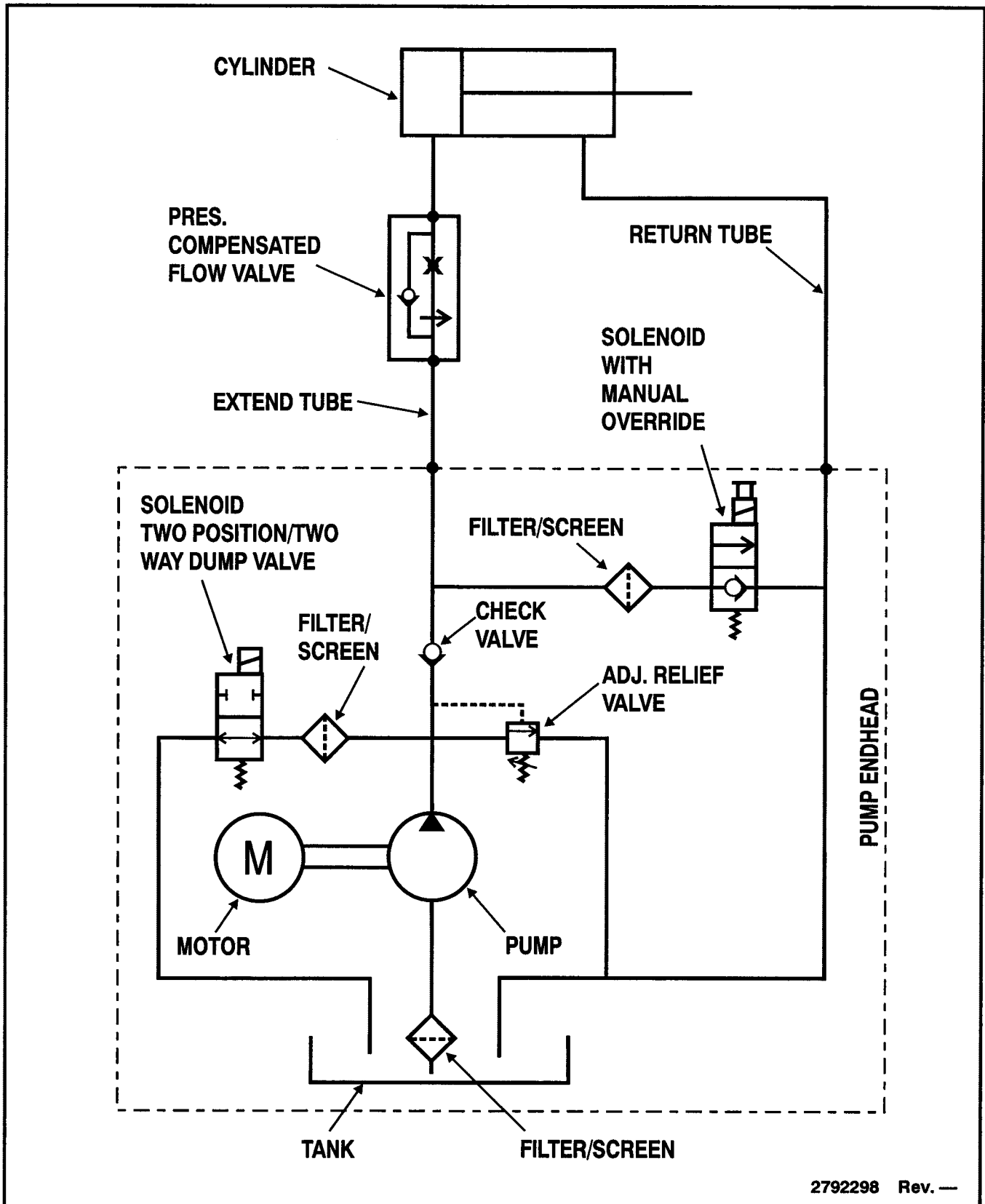

2792298 Rev. —

Figure 9-2. Hydraulic Schematic. (AC & DC Machines)

TABLE OF CONTENTS

TABLE OF CONTENTS

FIGURE NO.	DESCRIPTION	PAGE NO.
SECTION 10-1 — BASE		
10-1-1	Base Mounted Components Installation.....	10-1-2
10-1-2	Tilt Back Installation - 30 Ft. and 36 Ft. Machines	10-1-6
SECTION 10-2 — CONTROLS		
10-2-1	AC Power Components Installations	10-2-2
10-2-2	AC Junction Box Assembly.....	10-2-4
10-2-3	AC Motor/Pump Assembly	10-2-6
10-2-4	DC Power Components Installations	10-2-8
10-2-5	Battery Charger Assembly	10-2-12
10-2-6	DC Motor/Pump Assembly	10-2-14
10-2-7	Cables and Controls Installation.....	10-2-16
SECTION 10-3 — MAST		
10-3-1	Mast Assemblies - 19 Ft. and 24 Ft.....	10-3-2
10-3-2	Mast Assemblies - 30 Ft. and 36 Ft.....	10-3-6
10-3-3	Mast Mounted Components	10-3-10
SECTION 10-4 — PLATFORM		
10-4-1	Platform Component Installations.....	10-4-2
10-4-2	Fiberglass Platform Installation	10-4-4
SECTION 10-5 — CYLINDERS		
10-5-1	Lift Cylinder Assembly (Standard Parts)	10-5-2
SECTION 10-6 — HYDRAULICS		
10-6-1	Hydraulic Diagram	10-6-2
SECTION 10-7 — ELECTRICAL		
10-7-1	Electrical Diagrams and Components List	10-7-2
10-7-2	Electrical Diagram - 115VAC/60HZ	10-7-3
10-7-3	Electrical Diagram - 12VDC	10-7-4
SECTION 10-8 — DECALS		
10-8-1	Decals Installation.....	10-8-2
SECTION 10-9 — RECOMMENDED SERVICE PARTS STOCK.....		
		10-9-1
SECTION 10-10 — SPECIAL OPTIONS		
10-10-1	Miscellaneous Options List.....	10-10-1
10-10-2	Straddle Installation	10-10-2

SECTION 10-1 BASE

TABLE OF CONTENTS

FIGURE NO.	DESCRIPTION	PAGE NO.
10-1-1	Base Mounted Components Installation.....	10-1-2
10-1-2	Tilt Back Installation - 30 Ft. and 36 Ft. Machines	10-1-6

SECTION
10-1
BASE

SECTION 10-1 BASE

FIGURE 10-1-1. BASE MOUNTED COMPONENTS INSTALLATION.

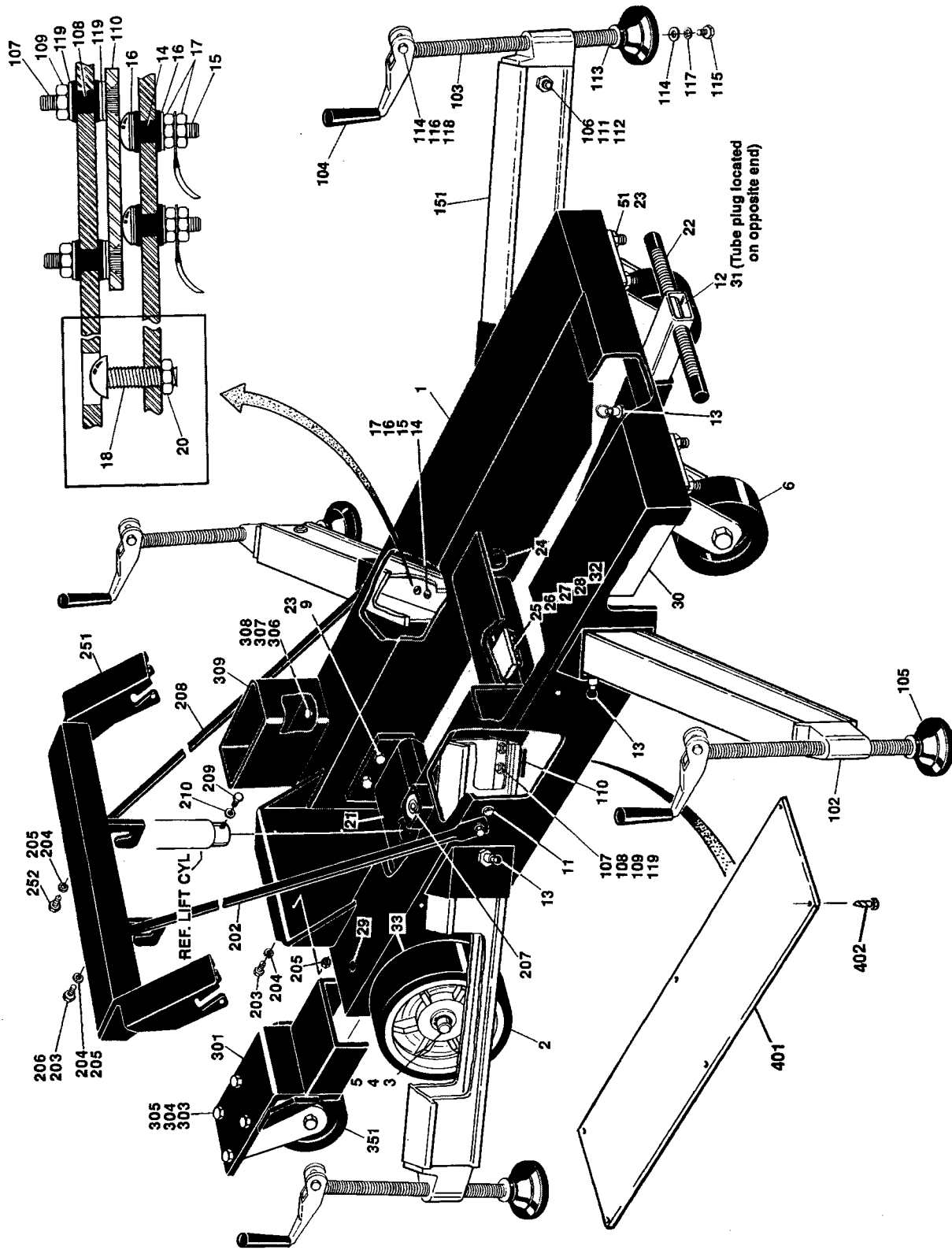

SECTION 10-1 BASE

SECTION 10-1 BASE

FIGURE & ITEM NO	PART NUMBER	DESCRIPTION	QTY.	REV.
10-1-1		BASE MOUNTED COMPONENTS INSTALLATION	Ref.	
	1282202	BASE ASSEMBLY	Ref.	L
-1	4844696	Base Weldment	1	
-2	4860150	Wheel Assembly - Stationary	2	
	7012645	Bearing, Roller (1 Per Wheel)	2	
	7012647	Retainer, Bearing (2 Per Wheel)	4	
	7012648	Spacer (2 Per Wheel)	4	
-3	4040236	Axle	1	
-4	3760348	Ring, Retaining	2	
-5	4712200	Flatwasher 3/4" Narrow	2	
-6	4860151	Wheel Assembly - Swivel	1	
	7012633	Bearing, Roller (1 Per Wheel)	2	
	7012634	Retainer, Bearing (2 Per Wheel)	4	
	7012632	Wheel, Replacement (With Bearing) (1 Per Wheel)	2	
	7012644	Axle Kit (1 Per Wheel)	2	
	7012636	Bushing, Axle Spanner (1 Per Wheel)	2	
-7	Not Used			
-8	Not Used			
-9	3311605	Locknut 3/8"-16NC	4	
-10	0100011	Loctite #242	A/R	
-11	2920121	Light, Indicator	4	
-12	4844791	Handle, Loading	1	
-13	3422369	Pin, Lock	5	
-14	2540024	Grommet	8	
-15	3900194	Screw, Brass #8-32NC x 5/8"	8	
-16	4740434	Washer, Nylon #8	24	
-17	3300379	Locknut, Brass #8-32NC	16	
-18	3900212	Screw, Button #4-40NC	A/R	
-19	Not Used			
-20	3310405	Locknut #4-40NC	A/R	
-21	4844697	Mount, Cylinder	1	
-22	2560088	Grip, Handle	2	
-23	4751600	Flatwasher 3/8"	8	
-24	2540025	Grommet	3	
-25	3740106	Relay	1	
-26	0641406	Bolt 1/4"-20NC x 3/4"	2	
-27	4751400	Flatwasher 1/4" (Prior to April 1995)	4	
	4751000	Flatwasher 1/4" (April 1995 to Present)	4	
-28	3311401	Nut 1/4"-20NC	2	
-29	3520034	Plug	4	
-30	3538526	Plate, Counterweight (36 Ft. Machines Only)	2	
-31	3520163	Plug, Tube	1	
-32	4921750	Harness, Base (July 1995 to Present)	1	
-33	4740456	Shims (S/N 10640 to Present)	A/R	
	0254806	BASE ASSEMBLY (19' AND 24')	Ref.	L
	0254805	BASE ASSEMBLY (30')	Ref.	L
-51	3300380	Locknut 3/8"-16NC	8	
	0254804	BASE ASSEMBLY (36')	Ref.	L
-51	0791610	Bolt 3/8"-16NC x 1"	8	

SECTION 10-1 BASE

SECTION 10-1 BASE

FIGURE & ITEM NO	PART NUMBER	DESCRIPTION	QTY.	REV.
10-1-1		BASE MOUNTED COMPONENTS INSTALLATION (CONTINUED)	Ref.	
		OUTRIGGER ASSEMBLY (STANDARD PARTS)	Ref.	
—101	Not Used			
—102	1220015	Cap, End (1 Per Assembly)	4	
—103	2840009	Jack, Threaded (1 Per Assembly)	4	
—104	2560127	Handle, Jack (1 Per Assembly)	4	
—105	3340712	Pad, Outrigger (1 Per Assembly)	4	
—106	0641624	Bolt 3/8"-16NC x 3" (1 Per Assembly)	4	
—107	3900193	Screw, Countersunk #8-32NC x 3/4" (1 Per Assembly)	8	
—108	2540024	Grommet (2 Per Assembly)	8	
—109	3300392	Locknut #8-32NC (2 Per Assembly)	8	
—110	4280291	Pad, Contact (1 Per Assembly)	4	
—111	3311605	Locknut 3/8"-16NC (1 Per Assembly)	4	
—112	4751600	Flatwasher 3/8" (1 Per Assembly)	2	
—113	4751800	Flatwasher 1/2" (1 Per Assembly)	4	
—114	4751400	Flatwasher 1/8" (2 Per Assembly)	8	
—115	0641405	Bolt 1/4"-20NC x 5/8" (1 Per Assembly)	4	
—116	0641410	Bolt 1/4"-20NC x 1 1/4" (1 Per Assembly)	4	
—117	4740430	Washer, Fender (1 Per Assembly)	4	
—118	3311405	Locknut 1/4"-20NC (1 Per Assembly)	4	
—119	4740434	Washer, Nylon #8 (6 Per Assembly)	24	
—120	0100019	Loctite #271 (Not Shown)	A/R	
—121	3020035	Lubricant, Silicone	A/R	
	0254803	OUTRIGGER ASSEMBLY - 19 FT. AND 24 FT. MACHINES (VARIABLE PARTS)	Ref.	D
—151	4566510	Beam, Outrigger (1 Per Assembly)	4	
	0254802	OUTRIGGER ASSEMBLY - 30 FT. MACHINES (VARIABLE PARTS)	Ref.	D
—151	4566509	Beam, Outrigger (1 Per Assembly)	4	
	0254795	OUTRIGGER ASSEMBLY - 36 FT. MACHINES (VARIABLE PARTS)	Ref.	D
—151	4566508	Beam, Outrigger (1 Per Assembly)	4	
		MAST SUPPORT INSTALLATION (STANDARD PARTS)	Ref.	
—201	Not Used			
—202	0880116	Brace	1	
—203	0641608	Bolt 3/8"-16NC x 1"	A/R	
—204	4761600	Lockwasher 3/8"	16	
—205	3311605	Locknut 3/8"-16NC	12	
—206	0641622	Bolt 3/8"-16NC x 2 3/4"	A/R	
—207	2420140	Gauge, Level	1	
—208	0880120	Brace	1	
—209	0661505	Bolt 5/16"-18NC x 5/8"	1	
—210	4711500	Flatwasher 5/16"	1	
—211	Not Used			

SECTION 10-1 BASE

SECTION 10-1 BASE

FIGURE & ITEM NO	PART NUMBER	DESCRIPTION	QTY.	REV.
10-1-1		BASE MOUNTED COMPONENTS INSTALLATION (CONTINUED)	Ref.	
	0254807	MAST SUPPORT INSTALLATION - 19 FT. AND 24 FT. MACHINES (VARIABLE PARTS)	Ref.	C
-251	4844795	Support Weldment (Not Shown)	1	
-252	0641612	Bolt 3/8"-16NC x 1 1/2"	1	
	0254867	MAST SUPPORT INSTALLATION - 30 FT. AND 36 FT. MACHINES (VARIABLE PARTS)	Ref.	C
-251	4844804	Support Weldment	1	
-252	0641626	Bolt 3/8"-16NC x 3 1/4"	1	
		OPTIONAL FOUR WHEEL SWIVEL INSTALLATION (STANDARD PARTS)	Ref.	
-301	4844859	Swivel Weldment - Rear	2	
-302	Not Used			
-303	0641608	Bolt 3/8"-16NC x 1"	8	
-304	3300380	Locknut, Flanged 3/8"-16NC	8	
-305	4751600	Flatwasher 3/8"	8	
-306	0641408	Bolt 1/4"-20NC x 1"	4	
-307	4751400	Flatwasher 1/4"	8	
-308	3311401	Nut 1/4"-20NC	4	
-309	4844873	Socket Weldment	2	
	0255074	OPTIONAL FOUR WHEEL SWIVEL INSTALLATION (VARIABLE PARTS)	Ref.	A/B
-351	4860143	Caster Wheel Assembly	2	
	7012641	Wheel, Replacement (1 Per Assembly)	2	
	7012630	Axle Kit (1 Per Assembly)	2	
	7012642	Bearing, Roller (1 Per Assembly)	2	
	7012631	Bushing, Spanner (1 Per Assembly)	2	
	7012628	Retainer (1 Per Assembly)	2	
	7012643	Spacer (2 Per Assembly)	4	
	0257051	OPTIONAL FOUR WHEEL SWIVEL INSTALLATION (POLYURETHANE CASTERS) (VARIABLE PARTS)	Ref.	—
-351	4860173	Caster Wheel Assembly	2	
	7020016	Wheel, Replacement (1 Per Assembly)	2	
	7016671	Axle Kit (1 Per Assembly)	2	
	7012633	Bearing, Roller (1 Per Assembly)	2	
	7020019	Bushing, Spanner (1 Per Assembly)	2	
	7012634	Retainer (1 Per Assembly)	2	
	7020015	Swivel Rig (1 Per Assembly)	2	
	0255670	OPTIONAL COVER PLATE INSTALLATION	Ref.	A
-401	3539041	Plate, Cover	2	
-402	3900222	Screw, Self-Tapping 1/4"-20NC x 3/8"	12	

SECTION 10-1 BASE

FIGURE 10-1-2. TILT BACK INSTALLATION - 30 FT. AND 36 FT. MACHINES.

SECTION 10-1 BASE

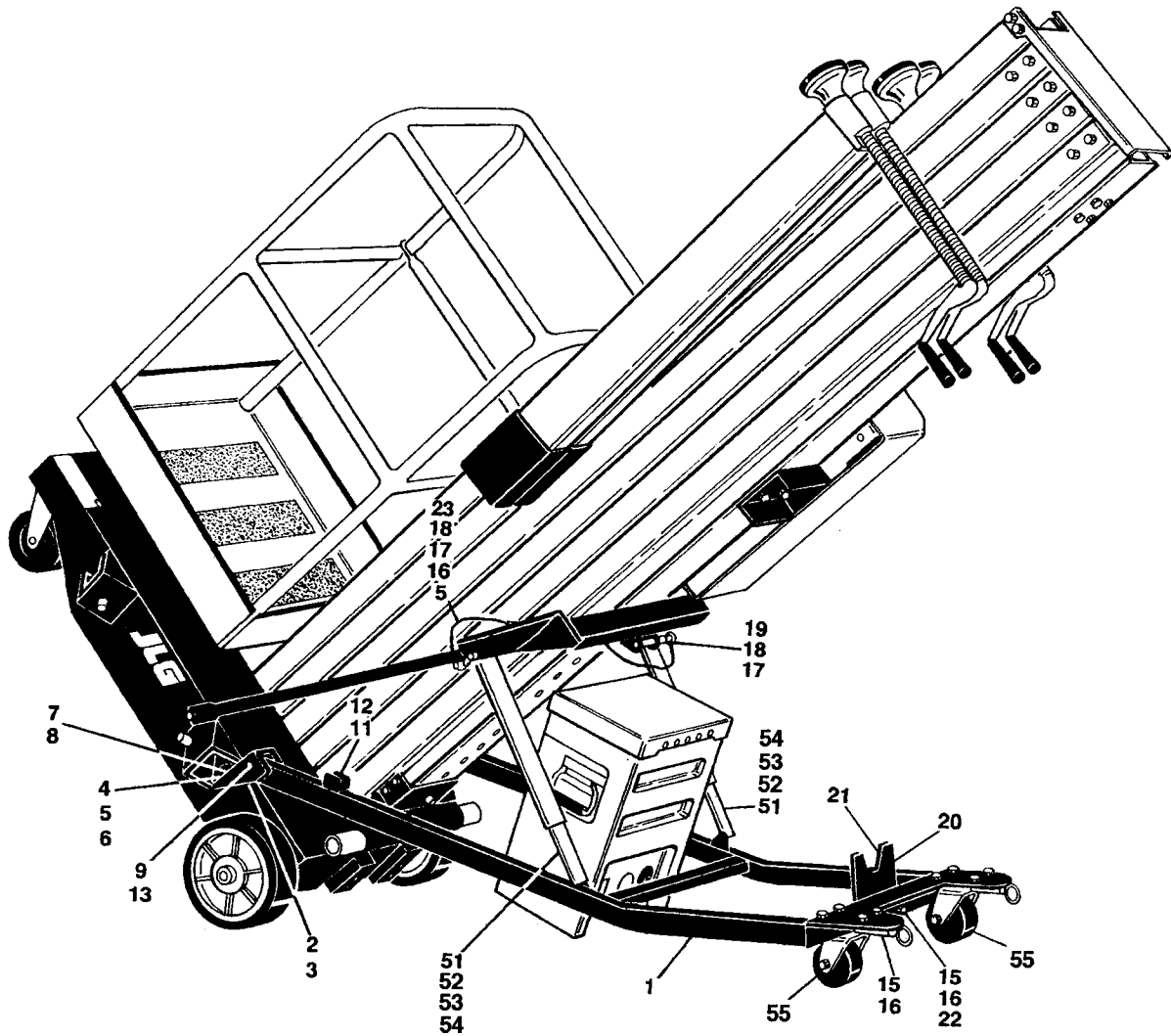

SECTION 10-1 BASE

SECTION 10-1 BASE

FIGURE & ITEM NO	PART NUMBER	DESCRIPTION	QTY.	REV.
10-1-2		TILT BACK INSTALLATION - 30 FT. AND 36 FT. MACHINES	Ref.	
		TILT BACK INSTALLATION (STANDARD PARTS)	Ref.	
-1	4844800	Tilt Back Weldment	1	
-2	4844798	Pivot (Right Side)	1	
-3	4844799	Pivot (Left Side)	1	
-4	3340715	Pad, Stop	2	
-5	3911412	Screw 1/4"-20NC x 3/4" (Prior to S/N 11027)	6	
	3911406	Screw 1/4"-20NC x 3/4" (S/N 11027 to Present)	6	
-6	3311405	Locknut 1/4"-20NC	6	
-7	0641508	Bolt 5/16"-18NC x 1"	6	
-8	3311505	Locknut 5/16"-18NC	6	
-9	0641616	Bolt 3/8"-16NC x 2"	2	
-10	Not Used			
-11	1320215	Clamp, Spring	2	
-12	3941004	Screw, Self-Tapping #10 x 1/2"	4	
-13	3311605	Locknut 3/8"-16NC	2	
-14	Not Used			
-15	0641608	Bolt 3/8"-16NC x 1"	10	
-16	3300380	Locknut, Flanged 3/8"-16NC	10	
-17	3420934	Pin, Quick Release	2	
-18	1060380	Cable, Lanyard	3	
-19	3941404	Screw, Self Tapping 1/4" x 1/2"	1	
-20	3538059	Plate, Stop	1	
-21	4060804	Flex-Trim (Prior to S/N 11410)	1 ft./3m	
	4060805	Flex-Trim (S/N 11410 to Present)	1 ft./3m	
-22	4751600	Flatwasher 3/8"	2	
-23	3420166	Pin, Quick Release	1	
	0254959	TILT BACK INSTALLATION - 30 FT. MACHINE (VARIABLE PARTS)	Ref.	5
-51	4160131	Spring Assembly	2	
-52	3900196	Bolt, Shoulder .38 x 1.25"	2	
-53	3311502	Nut .312-18	2	
-54	0100011	Loctite	A/R	
-55	4860156	Wheel Assembly - Swivel	2	
	7012642	Bearing, Roller (1 Per Assembly)	2	
	7012628	Retainer, Bearing (2 Per Assembly)	4	
	7012643	Spacer (2 Per Assembly)	4	
	7012629	Wheel, Replacement (With Bearing) (1 Per Assembly)	2	
	7012631	Bushing, Spanner (1 Per Assembly)	2	
	7012630	Axle Kit (1 Per Assembly)	2	
	Not Available	Lock, Swivel (1 Per Assembly)	2	

SECTION 10-1 BASE

SECTION 10-1 BASE

FIGURE & ITEM NO	PART NUMBER	DESCRIPTION	QTY.	REV.
10-1-2		TILT BACK INSTALLATION - 30 FT. AND 36 FT. MACHINES (CONTINUED)	Ref.	
	0257050	TILT BACK INSTALLATION - 30 FT. MACHINE (POLYURETHANE CASTERS - OPTION) (VARIABLE PARTS)	Ref.	2
-51	4160131	Spring Assembly	2	
-52	3900196	Bolt, Shoulder .38 x 1.25"	2	
-53	3311502	Nut .312-18	2	
-54	0100011	Loctite	A/R	
-55	4860171	Wheel Assembly - Swivel	2	
	7020014	Wheel, Replacement (1 Per Assembly)	2	
	7016671	Axle Kit (1 Per Assembly)	2	
	7012633	Bearing, Roller (1 Per Assembly)	2	
	7020019	Bushing, Spanner (1 Per Assembly)	2	
	7012634	Retainer (1 Per Assembly)	2	
	7020013	Swivel Rig (1 Per Assembly)	2	
	0254841	TILT BACK INSTALLATION - 36 FT. MACHINE (VARIABLE PARTS)	Ref.	5
-51	4160128	Spring Assembly	1	
-52	3900196	Bolt, Shoulder .38 x 1.25"	2	
-53	3311502	Nut .312-18	2	
-54	0100011	Loctite	A/R	
-55	4860156	Wheel Assembly - Swivel	2	
	7012642	Bearing, Roller (1 Per Assembly)	2	
	7012628	Retainer, Bearing (2 Per Assembly)	4	
	7012643	Spacer (2 Per Assembly)	4	
	7012629	Wheel, Replacement (With Bearing) (1 Per Assembly)	2	
	7012631	Bushing, Spanner (1 Per Assembly)	2	
	7012630	Axle Kit (1 Per Assembly)	2	
	Not Available	Lock, Swivel (1 Per Assembly)	2	
	0257052	TILT BACK INSTALLATION - 36 FT. MACHINE (POLYURETHANE CASTERS - OPTION) (VARIABLE PARTS)	Ref.	2
-51	4160128	Spring Assembly	2	
-52	3900196	Bolt, Shoulder .38 x 1.25"	2	
-53	3311502	Nut .312-18	2	
-54	0100011	Loctite	A/R	
-55	4860171	Wheel Assembly - Swivel	2	
	7020014	Wheel, Replacement (1 Per Assembly)	2	
	7016671	Axle Kit (1 Per Assembly)	2	
	7012633	Bearing, Roller (1 Per Assembly)	2	
	7020019	Bushing, Spanner (1 Per Assembly)	2	
	7012634	Retainer (1 Per Assembly)	2	
	7020013	Swivel Rig (1 Per Assembly)	2	

SECTION 10-2 CONTROLS

TABLE OF CONTENTS

FIGURE NO.	DESCRIPTION	PAGE NO.
10-2-1	AC Power Components Installations	10-2-2
10-2-2	AC Junction Box Assembly	10-2-4
10-2-3	AC Motor/Pump Assembly	10-2-6
10-2-4	DC Power Components Installations	10-2-8
10-2-5	Battery Charger Assembly	10-2-12
10-2-6	DC Motor/Pump Assembly	10-2-14
10-2-7	Cables and Controls Installation	10-2-16

**S
E
C
T
I
O
N

1
0
-
2

C
O
N
T
R
O
L
S**

SECTION 10-2 CONTROLS

FIGURE 10-2-1. AC POWER COMPONENTS INSTALLATION.

SECTION 10-2 CONTROLS

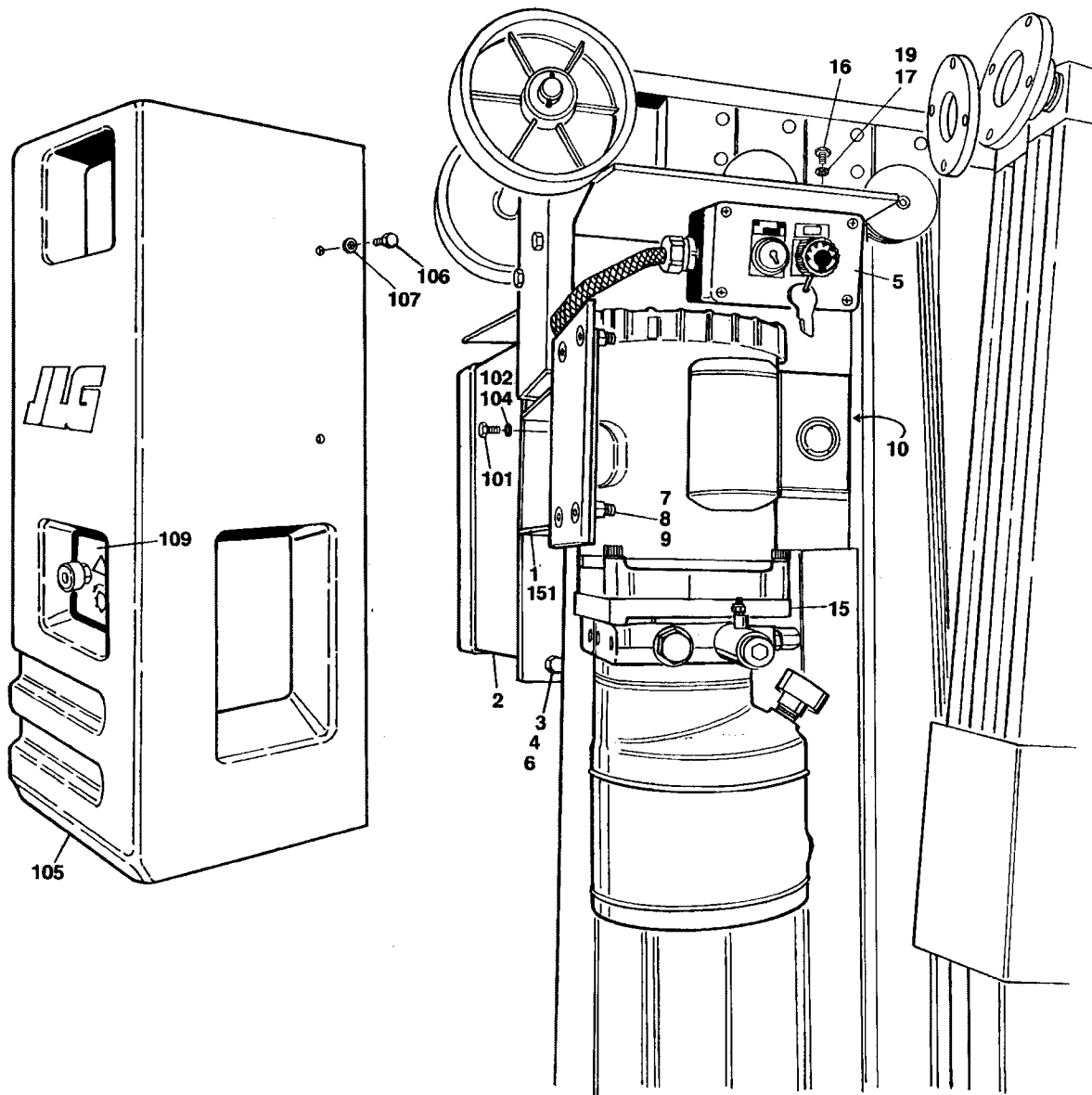

SECTION 10-2 CONTROLS

SECTION 10-2 CONTROLS

FIGURE & ITEM NO	PART NUMBER	DESCRIPTION	QTY.	REV.
10-2-1		AC POWER COMPONENT INSTALLATIONS	Ref.	
	0254809	POWERPACK ASSEMBLY	Ref.	F
—1	4844850	Plate, Mounting	1	
—2	0860933	Junction Box Assembly (See Figure 10-2-2 for Breakdown)		
—3	0641406	Bolt 1/4"-20NC x 3/4"	4	
—4	4751400	Flatwasher 1/4"	8	
—5	0860949	Ground Control Box Assembly	1	—
	7012635	Switch, Push-Pull (Stop)	1	
	7017706	Legend Plate, "Stop"	1	
	7017711	Legend Plate, "Power/Off/On"	1	
	7012636	Switch, Key (Lift)	1	
	7012640	Key, Replacement	1 set	
	7012637	Connector, Strain Relief	1	
—6	3311405	Locknut 1/4"-20NC	4	
—7	0641608	Bolt 3/8"-16NC x 1"	4	
—8	4751600	Flatwasher 3/8"	4	
—9	3311505	Locknut 5/16"-18NC	4	
—10	4460566	Connector, Terminal - 90°	1	
—11	Not Used			
—12	Not Used			
—13	Not Used			
—14	Not Used			
—15	3600239	Pump/Motor Assembly - 115VAC/60HZ (See Figure 10-2-3 for Breakdown)	1	
—16	3911010	Screw, Machine #10-24NC x 5/8"	2	
—17	4751000	Flatwasher #10	2	
—18	Not Used			
—19	3311001	Nut #10-24NC	2	
		POWERPACK INSTALLATION (STANDARD PARTS)	Ref.	
—101	0641608	Bolt 3/8"-16NC x 1"	4	
—102	4751600	Flatwasher 3/8"	8	
—103	Not Used			
—104	3311605	Locknut 3/8"-16NC	4	
—105	4060875	Cover, Pump/Motor	1	
—106	0641404	Bolt 1/4"-20NC x 1/2"	4	
—107	4751400	Flatwasher 1/4"	4	
—108	Not Used			
—109	1702353	Decal - Manual Descent	1	
	0254808	POWERPACK INSTALLATION (VARIABLE PARTS)	Ref.	E
—151	Not Required			
	0256774	POWERPACK INSTALLATION (AM-19) (VARIABLE PARTS)	Ref.	A/2
—151	4070930	Shim, Pump Mounting (S/N 10321 to Present)	A/R	

SECTION 10-2 CONTROLS

FIGURE 10-2-2. AC JUNCTION BOX ASSEMBLY.

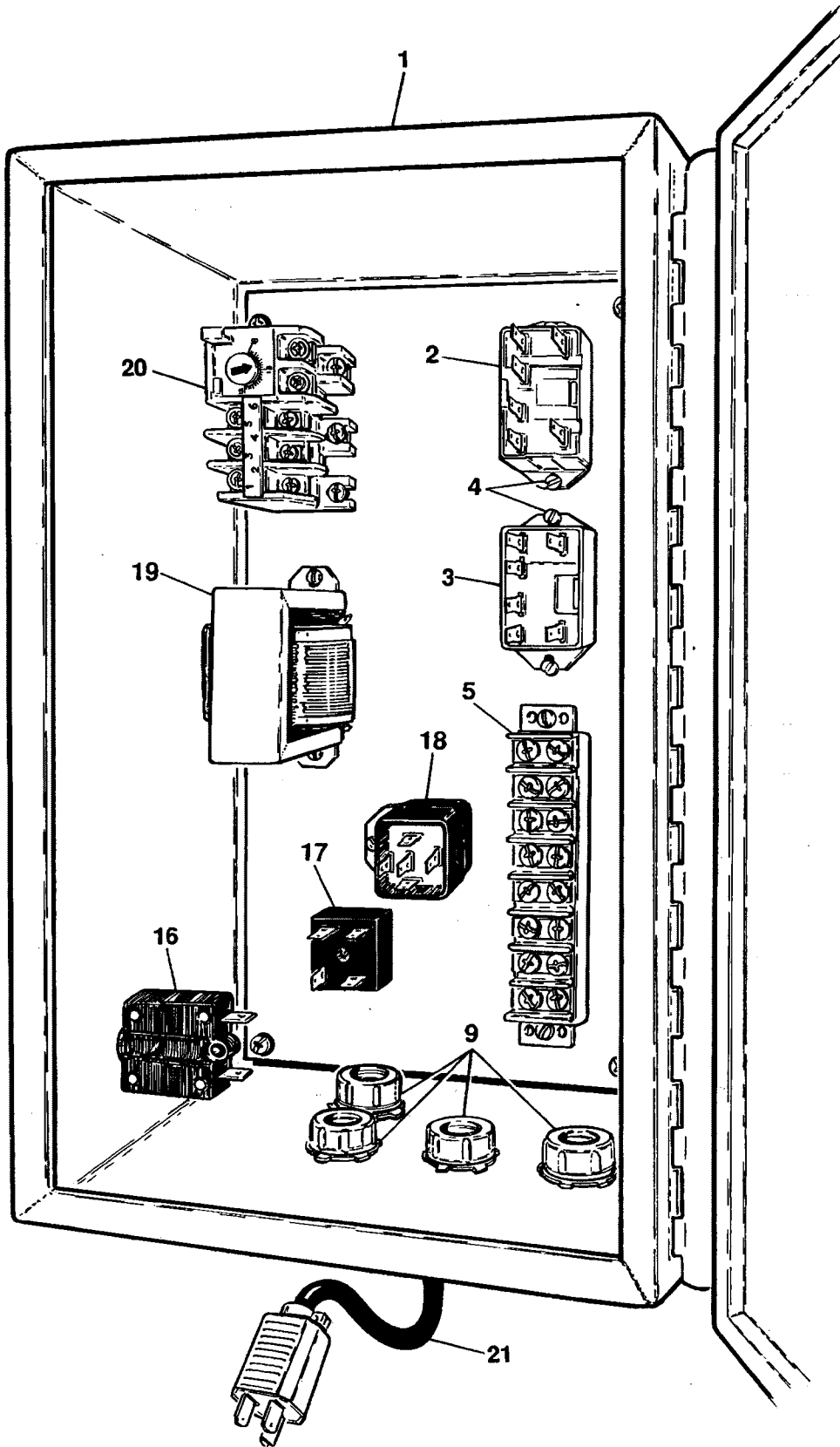

SECTION 10-2 CONTROLS

SECTION 10-2 CONTROLS

SECTION 10-2 CONTROLS

FIGURE & ITEM NO	PART NUMBER	DESCRIPTION	QTY.	REV.
10-2-2		AC JUNCTION BOX ASSEMBLY	Ref.	
	0860933	JUNCTION BOX ASSEMBLY - 115VAC/60HZ	Ref.	E
-1	0860911	Box with Lid	1	
-2	3740094	Relay, Starter - 12VDC	1	
-3	3740093	Relay, Starter - 115VAC	1	
-4	3910808	Screw #8-32NC x 1/2"	12	
-5	4460565	Strip, Terminal	1	
-6	Not Used			
-7	Not Used			
-8	Not Used			
-9	4460428	Connector, Strain Relief (Prior to S/N 10998)	4	
	4460633	Connector, Strain Relief (S/N 10998 to Present)	4	
-10	Not Used			
-11	Not Used			
-12	Not Used			
-13	Not Used			
-14	Not Used			
-15	Not Used			
-16	4360161	Breaker, Circuit - 20 Amp	1	
-17	4360376	Rectifier	1	
-18	3740049	Relay	1	
-19	4530010	Transformer 115/230VAC to 12VDC	1	
-20	3740098	Relay, Thermal Overload (Prior to S/N 10216)	1	
-21	4921663	Harness	1	
-22		Decal - 115V Options (Not Shown - Located on Front Cover) :	1	
	1702102	Prior to May 1995		
	1702569	May 1995 to Present		
-23	1702120	Decal - Wire Size (Not Shown - Located on Front Cover)	1	
-24	1702365	Decal - JLG (Not Shown - Located on Front Cover)	1	

SECTION 10-2 CONTROLS

FIGURE 10-2-3. AC MOTOR/PUMP ASSEMBLY.

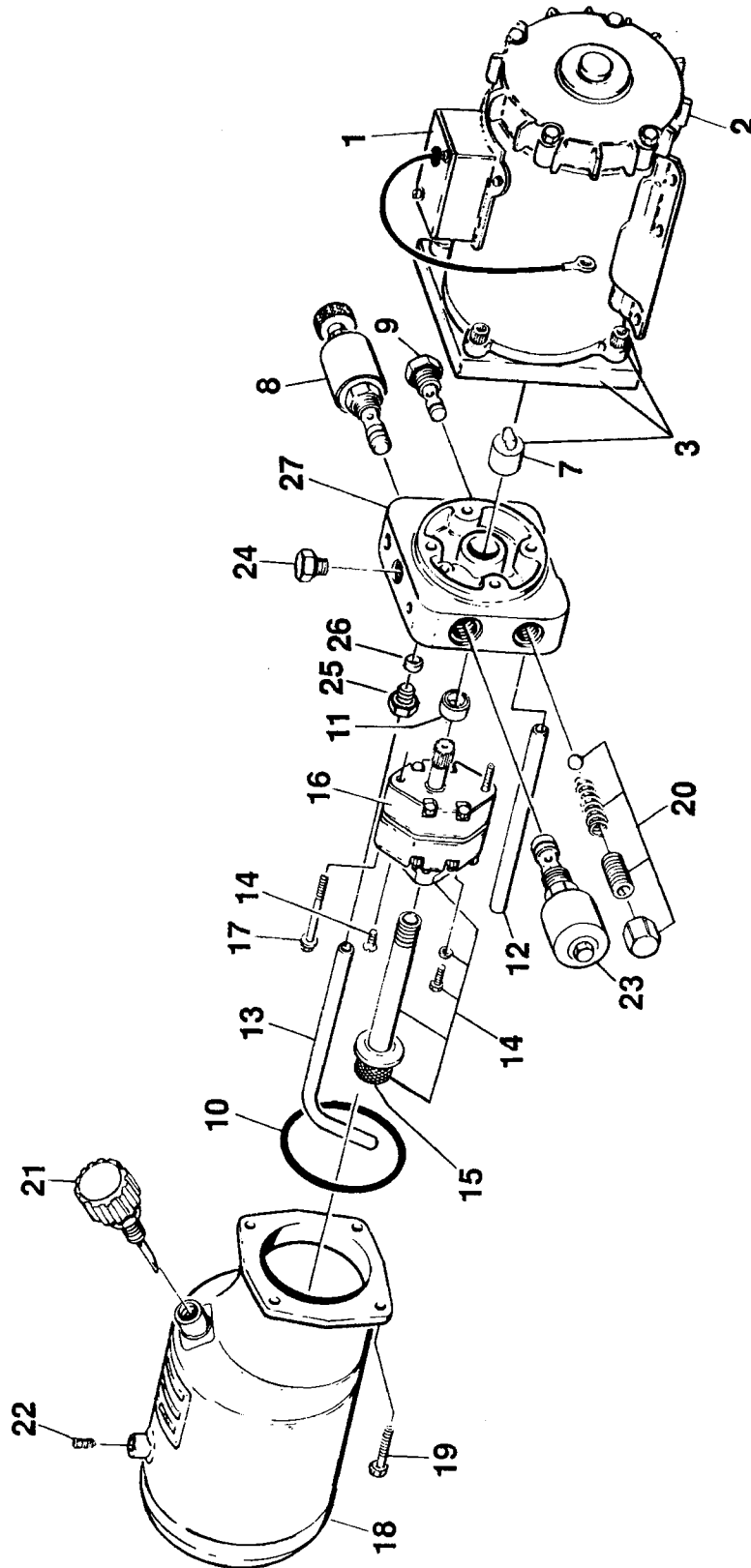

SECTION 10-2 CONTROLS

FIGURE & ITEM NO	PART NUMBER	DESCRIPTION	QTY.	REV.
10-2-3		AC MOTOR/PUMP ASSEMBLY	Ref.	
	3600239	MOTOR/PUMP ASSEMBLY - 115VAC/60HZ	Ref.	B
-1	7013787	Cover, Switchbox	1	
-2	7013788	Motor - 115VAC/60HZ (No Repair Parts Available)	1	
-3	7013782	Motor Adaptor Kit (Includes Item 7)	1	
-4	Not Used			
-5	Not Used			
-6	Not Used			
-7	7013729	Coupling (Part of Item 3)	1	
-8	7013764	Cartridge, Valve - Manual Descent	1	
-9	7013708	Cartridge, Valve - Check	1	
-10	7013743	O-Ring, Reservoir	1	
-11	7013701	Pump O-Ring Kit (For Item 16)	1	
-12	7013726	Tube, Return	1	
-13	7013791	Tube, Return - 90°	1	
-14	7013784	Inlet Plumbing Kit (Includes Item 15)	1	
-15	7013723	Filter (Part of Item 14)	1	
-16	7013747	Pump Assembly (See Item 11 for O-Ring Kit)	1	
-17	7013713	Bolt	2	
-18	7013785	Reservoir Assembly (Includes Items 19, 21 and 22)	1	
-19	7013740	Screw (Part of Item 18)	4	
-20	7013779	Valve Assembly	1	
-21	7013794	Breather/Dipstick Assembly (Part of Item 18)	1	
-22	7013719	Plug - 3/8" NPT (Part of Item 18)	1	
-23	7013786	Cartridge, Valve - Solenoid	1	
-24	7013714	Plug 9/16" SAE	1	
-25	7013792	Fitting	1	
-26	7013793	Sleeve	1	
-27	Not Available	End Head	1	

SECTION 10-2 CONTROLS

SECTION 10-2 CONTROLS

FIGURE 10-2-4. AC POWER COMPONENTS INSTALLATION.

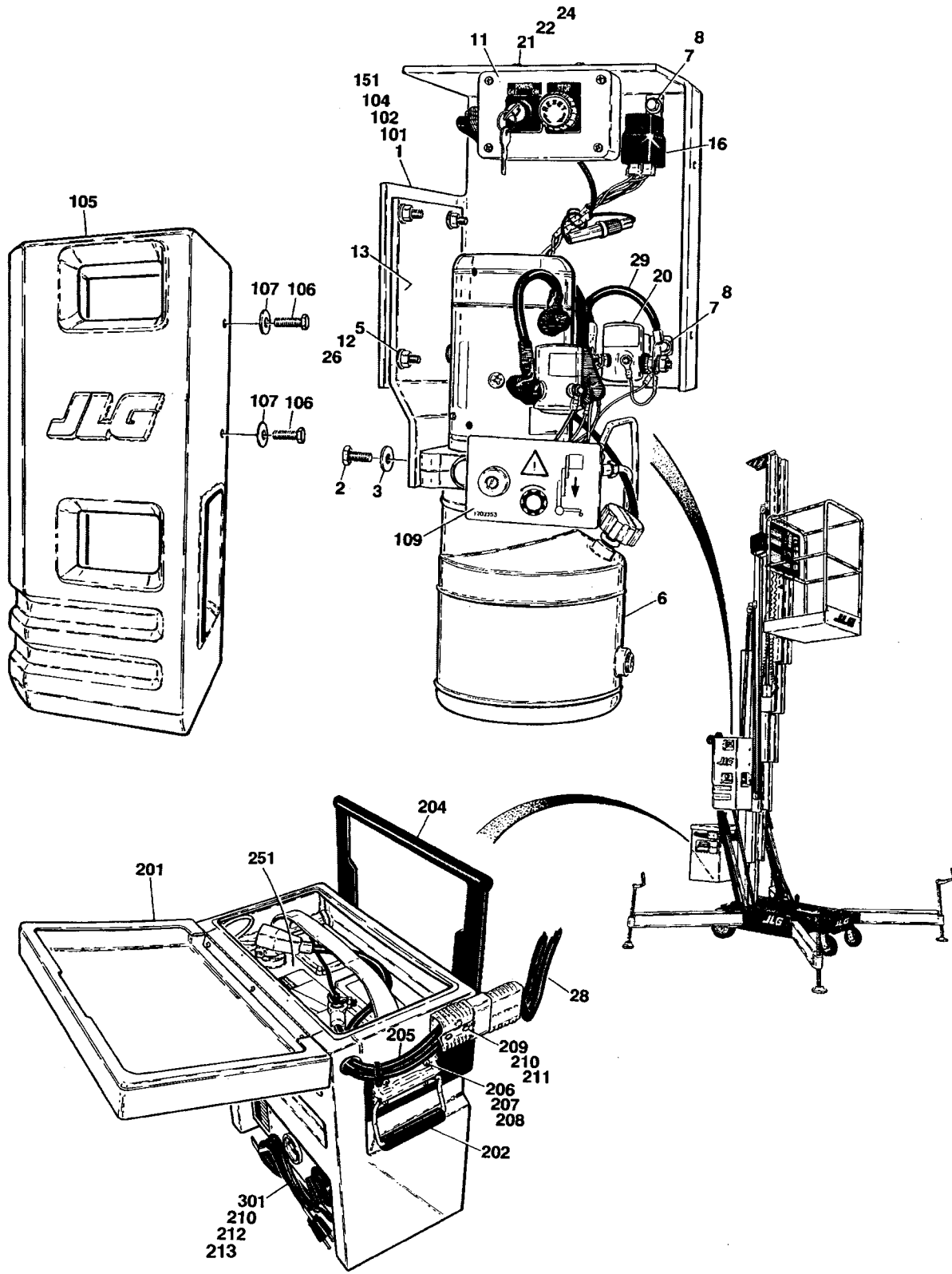

SECTION 10-2 CONTROLS

SECTION 10-2 CONTROLS

FIGURE & ITEM NO	PART NUMBER	DESCRIPTION	QTY.	REV.
10-2-4		DC POWER COMPONENTS INSTALLATIONS	Ref.	
	0254810	POWERPACK ASSEMBLY	Ref.	D
—1	4844851	Bracket	1	
—2	0641608	Bolt 3/8"-16NC x 1"	2	
—3	4751600	Flatwasher 3/8"	4	
—4	Not Used			
—5	0630486	Screw, Flathead 5/16"-18NC x 1"	4	
—6	3600238	DC Motor/Pump Assembly (See Figure 10-2-6 for Breakdown)	1	
—7	0641403	Bolt 1/4"-20NC x 3/8"	3	
—8	4761400	Lockwasher 1/4"	3	
—9	Not Used			
—10	Not Used			
—11	0860949	Ground Control Box Assembly	1	—
	7012635	Switch, Push-Pull (Stop)	1	
	7017706	Legend Plate, "Stop"	1	
	7017711	Legend Plate, "Power/Off/On"	1	
	7012636	Switch, Key (Lift)	1	
	7012640	Key, Replacement	1 set	
	7012637	Connector, Strain Relief	1	
—12	4751500	Flatwasher 5/16"	1	
—13	0902054	Plate, Mounting	1	
—14	Not Used			
—15	Not Used			
—16	3740080	Relay, Bosch	1	
—17	Not Used			
—18	Not Used			
—19	Not Used			
—20	3740013	Solenoid	1	
—21	3911010	Screw #10-24NC x 5/8"	2	
—22	4761000	Lockwasher #10	2	
—23	Not Used			
—24	3311001	Nut #10-24NC	2	
—25	Not Used			
—26	3311505	Locknut 5/16"-18NC	4	
—27	Not Used			
—28	1060571	Cable Assembly - Battery	1	
—29	1060518	Cable, Battery	1	
		POWERPACK INSTALLATION (STANDARD PARTS)	Ref.	
—101	0641608	Bolt 3/8"-16NC x 1"	4	
—102	4751600	Flatwasher 3/8"	8	
—103	Not Used			
—104	3311605	Locknut 3/8"-16NC	4	
—105	4060875	Cover, Pump/Motor	1	
—106	0641404	Bolt 1/4"-20NC x 1/2"	4	
—107	4751400	Flatwasher 1/4"	4	
—108	Not Used			
—109	1702353	Decal - Manual Descent	1	
	0254808	POWERPACK INSTALLATION (VARIABLE PARTS)	Ref.	E
—151	Not Required			

SECTION 10-2 CONTROLS

SECTION 10-2 CONTROLS

FIGURE & ITEM NO	PART NUMBER	DESCRIPTION	QTY.	REV.
10-2-4		DC POWER COMPONENTS INSTALLATIONS (CONTINUED)	Ref.	
	0256774	POWERPACK INSTALLATION (AM-19) (VARIABLE PARTS)	Ref.	A/2
-151	4070930	Shim, Pump Mounting (S/N 10321 to Present)	A/R	
		BATTERY BOX AND CHARGER INSTALLATION (STANDARD PARTS)	Ref. Ref.	
-201	0860942	Battery Box Assembly	1	—
	0860941	Lid	1	
	2600096	Hinge	1	
-202	2560135	Handle	2	
-203	Not Used			
-204	4844827	Mount, Battery Box	1	
-205	1060570	Cable Assembly	1	
-206	3911012	Screw, Machine #10-24NC x 3/4" (Prior to S/N 10640)	8	
	3911008	Screw, Machine #10-24NC x 1/2" (S/N 10640 to Present)	8	
-207	4751000	Flatwasher #10	8	
-208	3311001	Nut #10-24NC (Prior to S/N 11049)	8	
	3300408	Nut #10-24NC (S/N 11049 to Present)	8	
-209	0641410	Bolt 1/4"-20NC x 1 1/4"	2	
-210	4751400	Flatwasher 1/4"	8	
-211	3311401	Nut 1/4"-20NC	2	
-212	0641405	Bolt 1/4"-20NC x 5/8"	4	
-213	0100011	Loctite #242 (Prior to S/N 11027)	A/R	
	0100019	Loctite #271 (S/N 11027 to Present)	A/R	
	0254960	BATTERY BOX AND CHARGER INSTALLATION (VARIABLE PARTS)	Ref. Ref.	4
-251	0400122	Battery - Wet	1	
	0256038	BATTERY BOX AND CHARGER INSTALLATION (VARIABLE PARTS)	Ref. Ref.	2
-251	0400144	Battery - Dry	1	
-301		BATTERY CHARGER OPTIONS	Ref.	
	0400127	Battery Charger Assembly (100-115VAC) (See Figure 10-2-5 for Breakdown)	1	
	0400126	Battery Charger Assembly (200-240VAC) (See Figure 10-2-5 for Breakdown)	1	

SECTION 10-2 CONTROLS

SECTION 10-2 CONTROLS

FIGURE 10-2-5. BATTERY CHARGER ASSEMBLY.

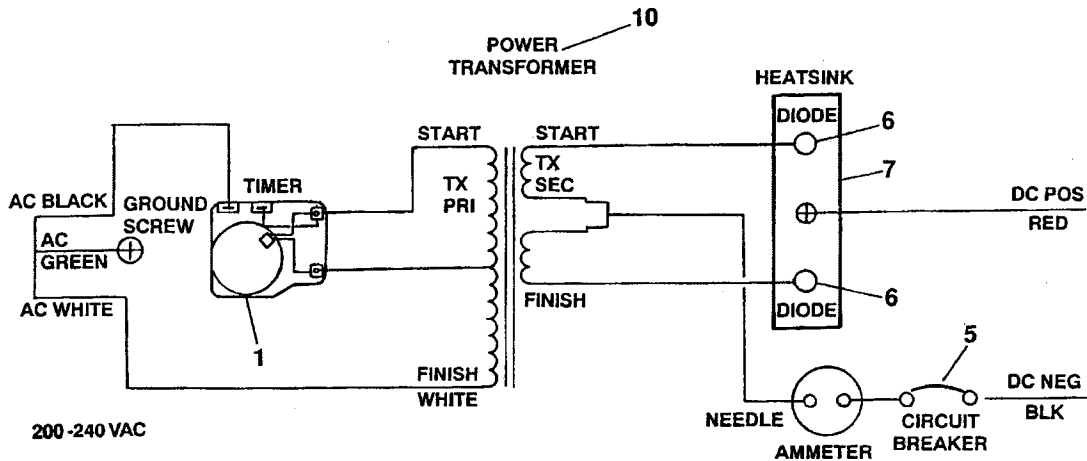
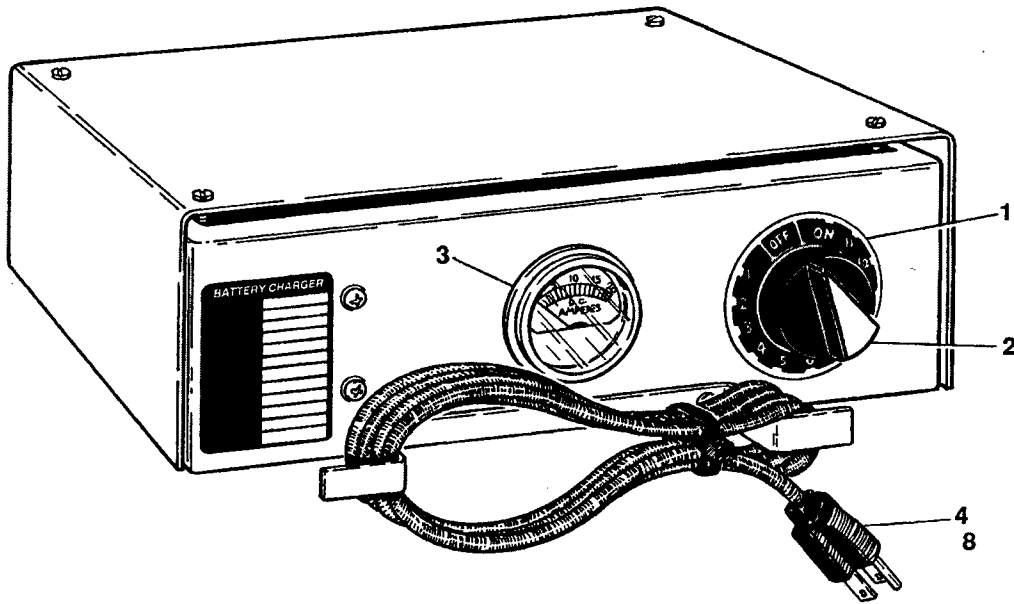
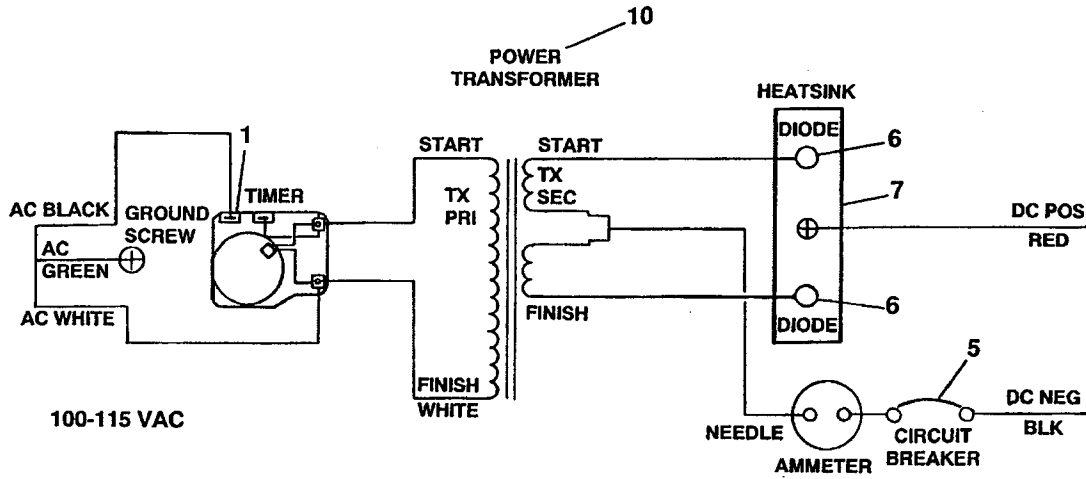

SECTION 10-2 CONTROLS

FIGURE & ITEM NO	PART NUMBER	DESCRIPTION	QTY.	REV.
10-2-5		BATTERY CHARGER ASSEMBLIES	Ref.	
	0400127	BATTERY CHARGER ASSEMBLY - 100-115VAC	Ref	—
	0400126	BATTERY CHARGER ASSEMBLY - 200-240VAC		
—1	7011639	Timer	1	
—2	7011505	Knob, Timer	1	
—3	7011632	Ammeter	1	
—4		Cord Options:	1	
	7011656	Cord (100-115VAC)		
	7011655	Cord (200-240VAC)		
—5	7011509	Breaker, Circuit	1	
—6	7011559	Diode - 20 Amp	2	
—7	Consult Factory	Rectifier Assembly	1	
—8	7011528	Connector, Strain Relief	2	
—9	7011637	Plate, Dial	1	
—10	Consult Factory	Transformer	1	
<p>Note: Battery Charger Serial Number Nameplate Located on right side of charger. First line is the Charger Spec and Date Code. Prior to Mid-February 1996 Example: BA515 (Spec) AP (Date Code). First Letter in the Date Code indicates Month (A - January/B - February/C - March/etc. with exception of Letter "I" which is not used). Second Letter indicates Year (N-1992/O-1993/P-1994/S-1995/T-1996 etc.). After Mid-February 1996 Example: BA515 (Spec) 9631 (Date Code). First and second digits in the Date Code indicate year. Third and Fourth digits indicate the week of manufacture.</p>				

SECTION 10-2 CONTROLS

SECTION 10-2 CONTROLS

FIGURE 10-2-6. DC MOTOR/PUMP ASSEMBLY.

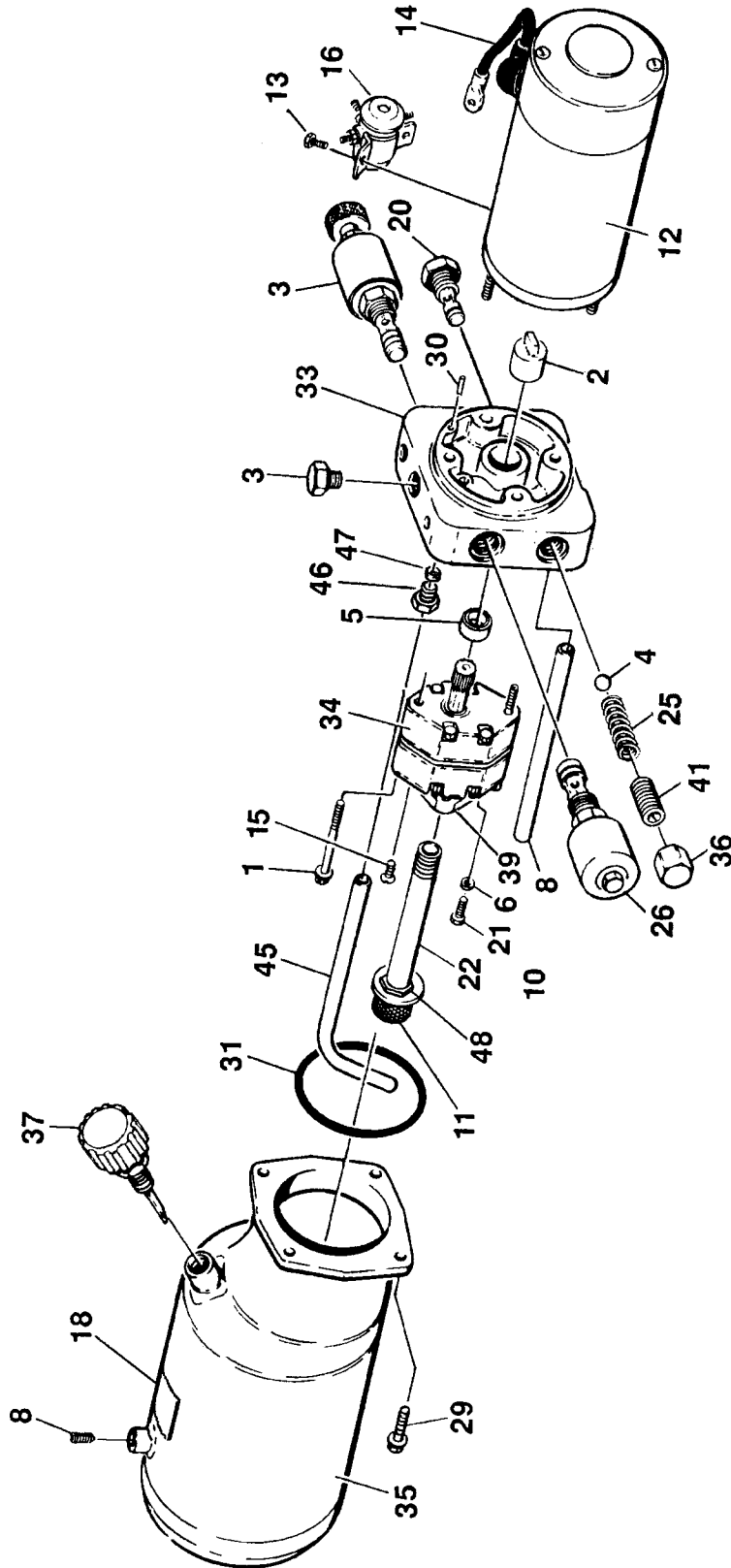

SECTION 10-2 CONTROLS

SECTION 10-2 CONTROLS

FIGURE & ITEM NO	PART NUMBER	DESCRIPTION	QTY.	REV.
10-2-6	3600238	DC MOTOR/PUMP ASSEMBLY	Ref.	A
-1	7013713	Bolt	2	
-2	7016735	Coupling	1	
-3	7013714	Plug 9/16 SAE	1	
-4	7013715	Ball	1	
-5	7013716	Seal, Shaft	1	
-6	7013717	Washer	1	
-7	Not Used			
-8	7013719	Plug 3/8NPT	1	
-9	Not Used			
-10	7013722	Magnet	1	
-11	7013723	Filter	1	
-12	7013710	Motor, DC	1	
-13	7013758	Screw, Taptite	2	
-14	Consult Factory	Cable Assembly	1	
-15	7013728	Screw, Taptite	2	
-16	7013760	Solenoid, Start	1	
-17	7013727	Cover, Suction	1	
-18	Not Serviced	Nameplate	1	
-19	Not Used			
-20	7013708	Valve, Cartridge Check	1	
-21	7016720	Bolt, Torx 5/16"-18NC x 1"	1	
-22	7016750	Plug	1	
-23	Not Used			
-24	Not Used			
-25	4640900	Spring	1	
-26	7016755	Cartridge	1	
-27	7013764	Cartridge	1	
-28	Not Used			
-29	7013740	Bolt, Washerhead	4	
-30	7013766	Pin	1	
-31	7013743	O-Ring	1	
-32	Not Used			
-33	7016753	Endhead	1	
-34	7013747	Pump Assembly	1	
-35	7016754	Tank	1	
-36	7013750	Cap, Relief	1	
-37	7013794	Breather/Dipstick	1	
-38	7013720	Plug 1/16 NPT	1	
-39	7013768	Tube, Return	1	
-40	Not Used			
-41	7013770	Screw, Valve Adjustment	1	
-42 to -44	Not Used			
-45	7013795	Tube, Return	1	
-46	7013792	Nut, Compression	1	
-47	7013793	Sleeve, Compression	1	
-48	7016722	Pipenut	1	

SECTION 10-2 CONTROLS

FIGURE 10-2-7. CABLES AND CONTROLS INSTALLATION.

SECTION 10-2 CONTROLS

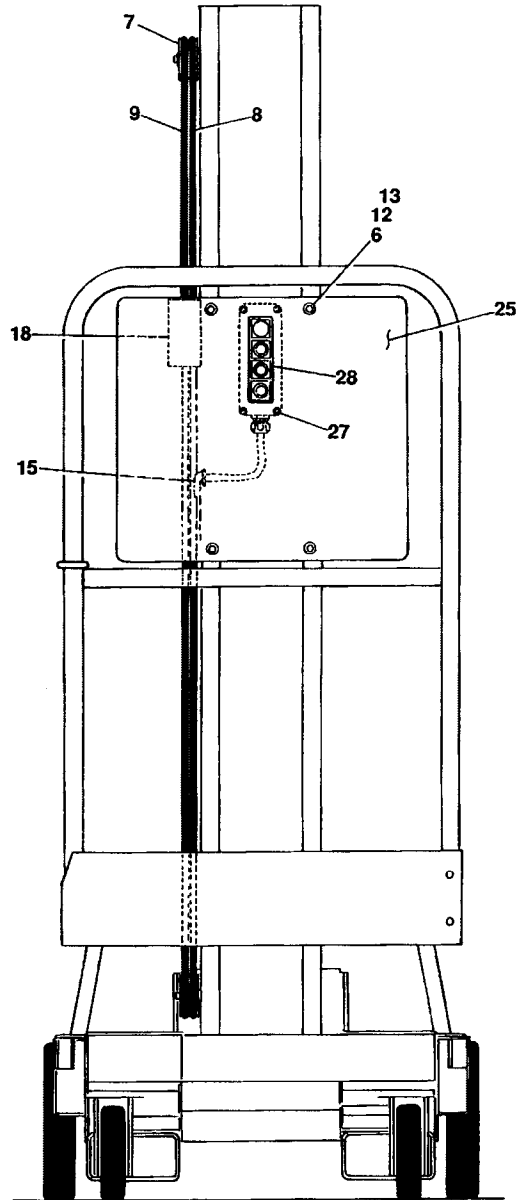
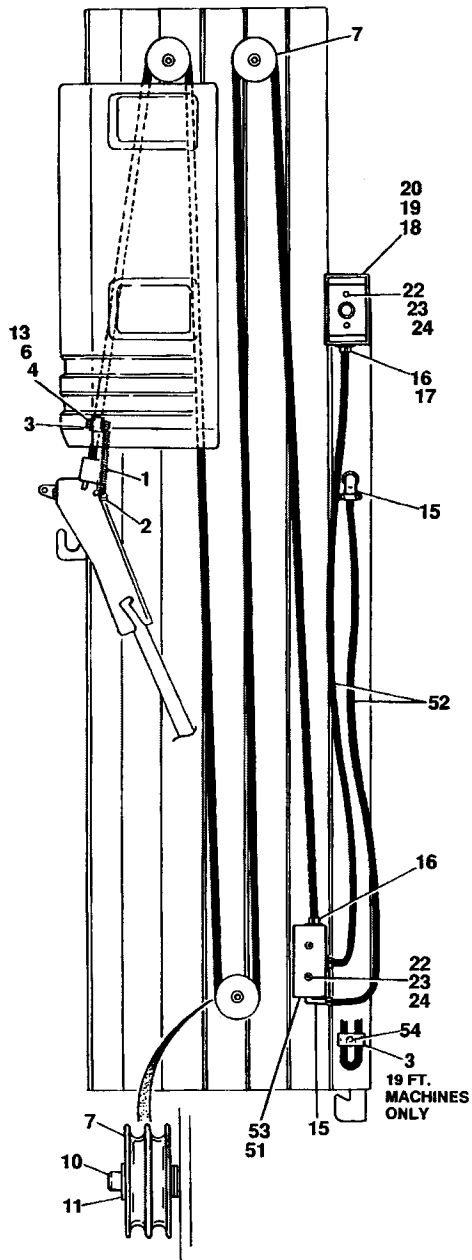

SECTION 10-2 CONTROLS

SECTION 10-2 CONTROLS

FIGURE & ITEM NO	PART NUMBER	DESCRIPTION	QTY.	REV.
10-2-7		CABLES AND CONTROLS INSTALLATION	Ref.	
	1282295	CABLES AND CONTROLS INSTALLATION (STANDARD PARTS)	Ref.	F
-1	4160130	Spring, Extension	1	
-2	3311605	Locknut 3/8"-16NC	1	
-3	1320149	Clamp (Prior to S/N 10786)	A/R	
	1320238	Clamp (S/N 10786 to Present)	A/R	
-4	0641410	Bolt 1/4"-20NC x 1 1/4"	1	
-5	0100019	Loctite #271 (Not Shown)	A/R	
-6	3311405	Locknut 1/4"-20NC	5	
-7	3580231	Sheave, Cable	3	
-8	1060563	Cable, Electrical 16/4	A/R	
		19 Ft. Machines	24 ft.	
		24 Ft. Machines	20 ft.	
		30 Ft. Machines	26 ft.	
		36 Ft. Machines	32 ft.	
-9	1060564	Cable, Electrical - 12/3	A/R	
		19 Ft. Machines	26 ft.	
		24 Ft. Machines	22 ft.	
		30 Ft. Machines	29 ft.	
		36 Ft. Machines	32 ft.	
-10	3900200	Screw, Shoulder 5/16"-18NC x 1 1/4"	3	
-11	4751500	Flatwasher 5/16"	3	
-12	0641406	Bolt 1/4"-20NC x 3/4"	4	
-13	4711400	Flatwasher 1/4" Narrow	19	
-14	Not Used			
-15	4460566	Connector, Strain Relief - 90°	A/R	
-16	4460023	Connector, Strain Relief (Prior to S/N 10321)	A/R	
	4460633	Connector, Strain Relief (S/N 10321 to Present)	A/R	
-17	0960407	Bushing (Prior to S/N 10321)	1	
-18	0860946	Box, Receptacle	1	
-19	4460190	Receptacle	1	
-20	4060092	Cover, Box	1	
-21	Not Used			
-22	0721006	Screw, Machine #10-24NC x 3/4"	A/R	
-23	4761000	Lockwasher #10	A/R	
-24	3311001	Nut #10-24NC	A/R	
-25	3380415	Panel, Control	1	
-26	Not Used			
-27	4740426	Washer #8 Nylon	4	
-28	1600201	Platform Control Box Assembly	1	
	7012635	Switch, Push-Pull (Red)	1	
	7012638	Switch, Push Button (White)	2	
	7012639	Switch, Push Button (Green)	1	
	7012637	Connector, Strain Relief	1	
	0254920	CABLES AND CONTROLS INSTALLATION - 19 FT. MACHINES (VARIABLE PARTS)	Ref.	C/4
-51	Not Required			
-52	Not Required			
-53	Not Required			
-54	0641416	Bolt 1/4"-20NC x 2"	1	

SECTION 10-2 CONTROLS

SECTION 10 - 2 CONTROLS

FIGURE & ITEM NO	PART NUMBER	DESCRIPTION	QTY.	REV.
10-2-7		CABLES AND CONTROLS INSTALLATION (CONTINUED)	Ref.	
	0254921	CABLES AND CONTROLS INSTALLATION - 24 FT. MACHINES (VARIABLE PARTS)	Ref.	6
	0254922	CABLES AND CONTROLS INSTALLATION - 30 FT. MACHINES (VARIABLE PARTS)	Ref.	6
	0254923	CABLES AND CONTROLS INSTALLATION - 36 FT. MACHINES (VARIABLE PARTS)	Ref.	E
—51	0860945	Box, Junction	1	
—52	1060565	Cable, Electrical - 16/4	A/R	
—53	1670603	Cover, Box	1	
—54	Not Required			

SECTION 10-3 MAST

TABLE OF CONTENTS

FIGURE NO.	DESCRIPTION	PAGE NO.
10-3-1	Mast Assemblies - 19 Ft. and 24 Ft.	10-3-2
10-3-2	Mast Assemblies - 30 Ft. and 36 Ft.	10-3-6
10-3-3	Mast Mounted Components	10-3-10

**S
E
C
T
I
O
N

1
0
-
3

M
A
S
T**

SECTION 10-3 MAST

FIGURE 10-3-1. MAST ASSEMBLIES - 19 FT. AND 24 FT.

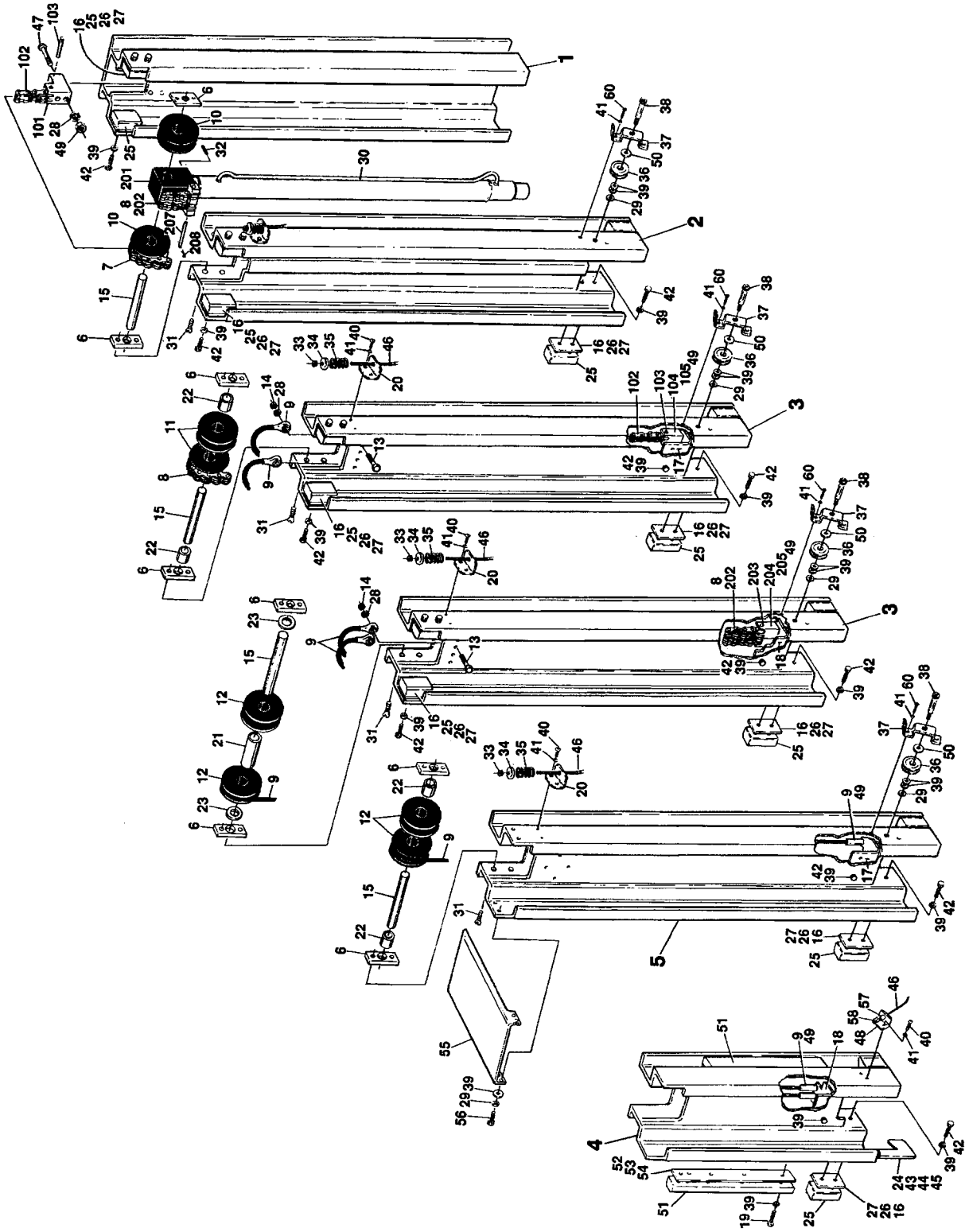

SECTION 10-3 MAST

SECTION 10-3 MAST

FIGURE & ITEM NO	PART NUMBER	DESCRIPTION	QTY		REV.
			19 FT.	24 FT.	
10-3-1		MAST ASSEMBLIES - 19 FT. AND 24 FT.	Ref.	Ref.	
	0800929	MAST ASSEMBLY - 19 FT.	Ref.		8
	0800928	MAST ASSEMBLY - 24 FT.		Ref.	8
		NOTE: FOR 24 FT. (ALL CHAIN) DRIVEN MAST ASSEMBLY SEE SECTION 10-10.			
-1	1271237	Channel - Mast #1	1	1	
-2	1271238	Channel - Mast #2	1	1	
-3	1271239	Channel - Masts #3 and #4	1	2	
-4	1271229	Channel - Mast #6	1	1	
-5	1271240	Channel - Mast #5	1	1	
-6	0362377	Bar, Sheave Pin	6	8	
-7	1260305	Chain Assembly - #466 Chain (See Items 101-106 for Breakdown)	2	2	
-8	1260306	Chain Assembly - #444 Chain (See Items 201-208 for Breakdown)	1	1	
-9	1060546	Cable Assembly (Prior to S/N 01577)	2	4	
	1060653	Cable Assembly (S/N 01577 to Present)	2	4	
-10	3580227	Sheave Assembly - #466 Chain	2	2	
	0961890	Bushing	2	2	
-11	3580226	Sheave Assembly - #444 Chain	2	2	
	0961889	Bushing	2	2	
-12	3580217	Sheave, Cable	2	4	
-13	0641610	Bolt 3/8"-16NC x 1 1/4"	2	4	
-14	3311605	Locknut 3/8"-16NC	6	8	
-15	3422361	Pin, Sheave	3	4	
-16	4070860	Shim (.075")	16	20	
-17	0901992	Bracket, Chain Attach (Bottom)	2	2	
-18	0901993	Bracket, Chain Attach (Bottom)	1	2	
-19	0641410	Bolt 1/4"-20NC x 1 1/4"	10	10	
-20	0902047	Bracket, Cable	3	4	
-21	4566486	Tube, Spacer	1	1	
-22	4566487	Tube, Spacer	2	4	
-23	4712600	Flatwasher 1" Narrow	2	2	
-24	0362378	Bar, Latch	1	1	
-25	3340704	Pad, Wear	14	18	
-26	4070861	Shim (.036")	2	2	
-27	4070862	Shim (.015")	9	9	
-28	4751600	Flatwasher 3/8"	8	12	
-29	4761400	Lockwasher 1/4"	3	4	
-30	1683201	Cylinder Assembly (See Section 5 for Breakdown)	1	1	
-31	3900192	Screw, Countersunk 3/8"-16NC x 1/2"	12	16	
-32	3900206	Bolt 1/4"-28NF x 5/8"	1	1	
-33	3311405	Locknut 1/4"-20NC	3	4	
-34	4740414	Cupwasher	3	4	
-35	4160124	Spring	3	4	
-36	3580228	Sheave, Cable	3	4	
-37	0902042	Bracket, Pulley	3	4	
-38	3900187	Bolt, Shoulder 5/16"-18NC x 1/2"	3	4	
-39	4711400	Flatwasher 1/4" Narrow	68	70	
-40	3900191	Screw, Countersunk #10-24NC x 3/8"	8	10	
-41	4761000	Lockwasher #10	14	18	
-42	0641406	Bolt 1/4"-20NC x 3/4"	34	44	

SECTION 10 - 3 MAST

SECTION 10-3 MAST

SECTION 10 - 3 MAST

FIGURE & ITEM NO	PART NUMBER	DESCRIPTION	QTY		REV.
			19 FT.	24 FT.	
10-3-1		MAST ASSEMBLIES - 19 FT. AND 24 FT. (CONTINUED)	Ref.	Ref.	
—43	0961892	Bushing, Flanged	2	2	
—44	3900190	Bolt, Socket Head 3/8"-16NC x 1/2"	1	1	
—45	3311502	Nut, Jam 5/16"-18NC	1	1	
—46	1060541	Cable, Sequence	4	4	
—47	0641620	Bolt 3/8"-16NC x 2 1/2"	4	4	
—48	0902084	Bracket, Cable (Lower)	1	1	
—49	3311601	Nut 3/8"-16NC	12	16	
—50	4751500	Flatwasher 5/16"	3	4	
—51	3340709	Pad, Wear	2	2	
—52	4070875	Shim (.075")	2	2	
—53	4070876	Shim (.036")	1	1	
—54	4070877	Shim (.015")	1	1	
—55	4060877	Shield, Cover	1	1	
—56	0641404	Bolt 1/4"-20NC x 1/2"	4	4	
—57	See Note	Stop, Cable (Note: Use 7016345 clamp in place of original P/N 4220160)	4		
—58	See Note	Connector (Note: Use 7016345 clamp in place of original P/N 4460121)	4		
—59	3020028	Lubricant, Graphkote (Not Shown)	A/R	A/R	
—60	3900205	Screw #10-24NC x 1/2"	6	8	
	1260305	CHAIN ASSEMBLY - #466 CHAIN	Ref.	Ref.	B
—101	0561156	Block	1	1	
—102	1260299	Chain	68 in.	68 in.	
—103	3422346	Pin, Grooved (Prior to May 1995)	2	2	
	3422265	Pin (May 1995 to Present)	2	2	
	3450201	Pin, Cotter 1/16" x 1/2" (May 1995 to Present)	4	4	
—104	0561150	Block	1	1	
—105	4300111	Stud	1	1	
—106	0100019	Loctite #271 (Not Shown) (Prior to S/N 10998)	A/R		
	0100062	Loctite #RC680 (Not Shown) (S/N 10998 to Present)	A/R		
	1260306	CHAIN ASSEMBLY - #444 CHAIN	Ref.	Ref.	B
—201	0561159	Block	1	1	
—202	1260298	Chain	137 in.	137 in.	
—203	3422346	Pin, Grooved	2	2	
—204	0561151	Block	2	2	
—205	4300111	Stud	2	2	
—206	0100019	Loctite #271 (Not Shown) (Prior to S/N 10998)	A/R		
	0100062	Loctite #RC680 (Not Shown) (S/N 10998 to Present)	A/R		
—207	3422266	Pin (Prior to August 1994)	1	1	
	3422407	Pin (August 1994 to Present)	1	1	
—208	3450201	Pin, Cotter	2	2	

SECTION 10-3 MAST

FIGURE 10-3-2. MAST ASSEMBLIES - 30 FT. AND 36 FT.

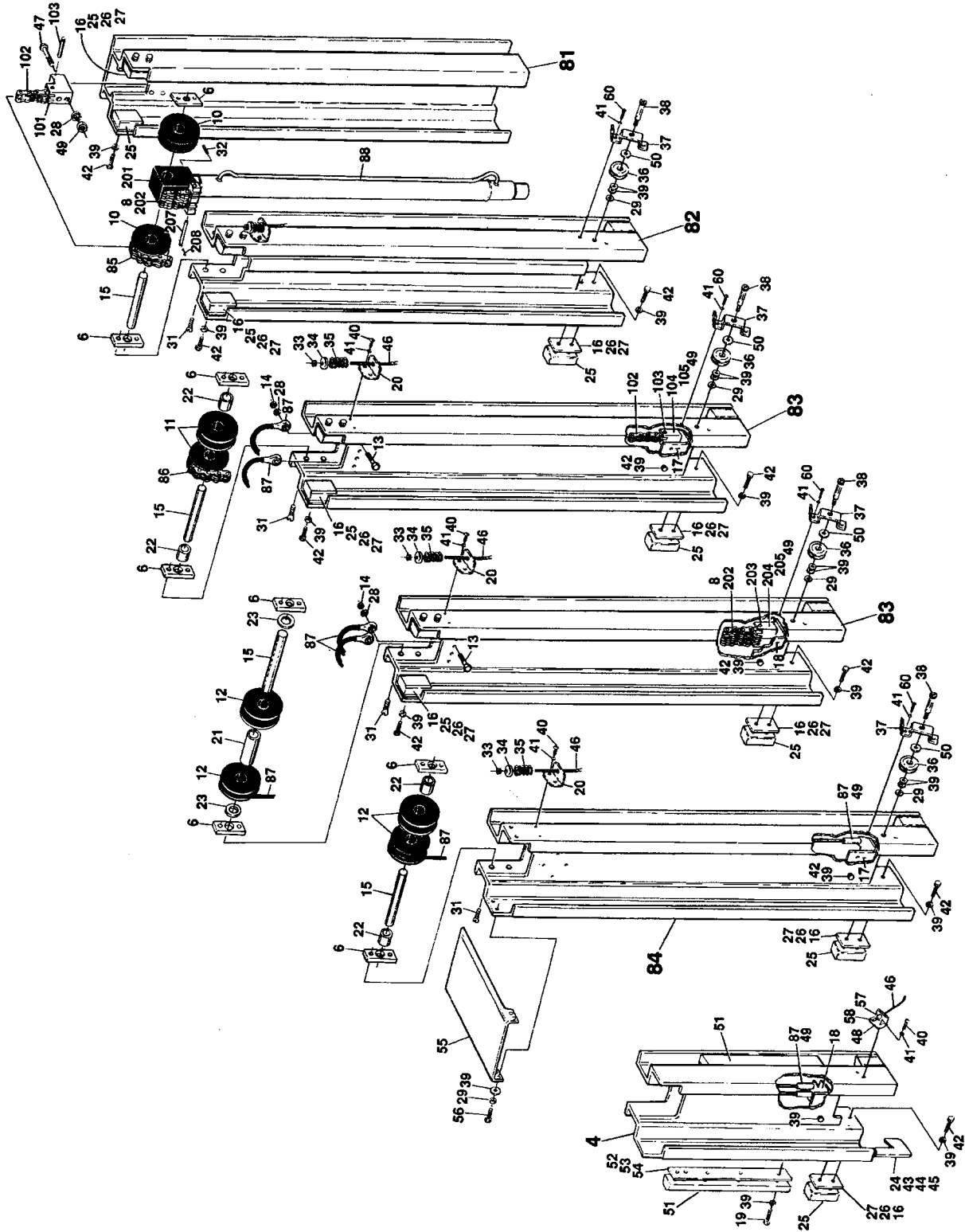

SECTION 10-3 MAST

FIGURE & ITEM NO	PART NUMBER	DESCRIPTION	QTY.	REV.
10-3-2		MAST ASSEMBLIES - 30 FT. AND 36 FT.	Ref.	
		MAST ASSEMBLY (STANDARD PARTS)	Ref.	
-1	Not Used			
-2	Not Used			
-3	Not Used			
-4	1271229	Channel - Mast #6	1	
-5	Not Used			
-6	0362377	Bar, Sheave Pin	8	
-7	Not Used			
-8	Not Used			
-9	Not Used			
-10	3580227	Sheave Assembly - #466 Chain	2	
	0961890	Bushing	2	
-11	3580226	Sheave Assembly - #444 Chain	2	
	0961889	Bushing	2	
-12	3580217	Sheave, Cable	4	
-13	0641610	Bolt 3/8"-16NC x 1 1/4"	4	
-14	3311605	Locknut 3/8"-16NC	8	
-15	3422361	Pin, Sheave	4	
-16	4070860	Shim (.075")	20	
-17	0901992	Bracket, Chain Attach (Bottom)	2	
-18	0901993	Bracket, Chain Attach (Bottom)	2	
-19	0641410	Bolt 1/4"-20NC x 1 1/4"	10	
-20	0902047	Bracket, Cable	4	
-21	4566486	Tube, Spacer	1	
-22	4566487	Tube, Spacer	4	
-23	4712600	Flatwasher 1" Narrow	2	
-24	0362378	Bar, Latch	1	
-25	3340704	Pad, Wear	18	
-26	4070861	Shim (.036")	2	
-27	4070862	Shim (.015")	9	
-28	4751600	Flatwasher 3/8"	12	
-29	4761400	Lockwasher 1/4"	4	
-30	Not Used			
-31	3900192	Screw, Countersunk 3/8"-16NC x 1/2"	16	
-32	3900206	Bolt 1/4"-28NF x 5/8"	1	
-33	3311405	Locknut 1/4"-20NC	4	
-34	4740414	Cupwasher	4	
-35	4160124	Spring	4	
-36	3580228	Sheave, Cable	4	
-37	0902042	Bracket, Pulley	4	
-38	3900187	Bolt, Shoulder 5/16"-18NC x 1/2"	4	
-39	4711400	Flatwasher 1/4" Narrow	70	
-40	3900191	Screw, Countersunk #10-24NC x 3/8"	10	
-41	4761000	Lockwasher #10	18	
-42	0641406	Bolt 1/4"-20NC x 3/4"	44	
-43	0961892	Bushing, Flanged	2	

SECTION 10-3 MAST

SECTION 10-3 MAST

SECTION 10-3 MAST

FIGURE & ITEM NO	PART NUMBER	DESCRIPTION	QTY.	REV.
10-3-2		MAST ASSEMBLIES - 30 FT. AND 36 FT. (CONTINUED)	Ref.	
—44	3900190	Bolt, Socket Head 3/8"-16NC x 1/2"	1	
—45	3311502	Nut, Jam 5/16"-18NC	1	
—46	1060541	Cable, Sequence	4	
—47	0641620	Bolt 3/8"-16NC x 2 1/2"	4	
—48	0902084	Bracket, Cable (Lower)	1	
—49	3311601	Nut 3/8"-16NC	16	
—50	4751500	Flatwasher 5/16"	4	
—51	3340709	Pad, Wear	2	
—52	4070875	Shim (.075")	2	
—53	4070876	Shim (.036")	1	
—54	4070877	Shim (.015")	1	
—55	4060877	Shield, Cover	1	
—56	0641404	Bolt 1/4"-20NC x 1/2"	4	
—57	See Note	Stop, Cable (Note: Use 7016345 clamp in place of original P/N 4220160)	4	
—58	See Note	Connector (Note: Use 7016345 clamp in place of original P/N 4460121)	4	
—59	3020028	Lubricant, Graphkote (Not Shown)	A/R	
—60	3900205	Screw #10-24NC x 1/2"	8	
	0800927	MAST ASSEMBLY - 30FT (VARIABLE PARTS)	Ref.	8
—81	1271233	Channel - Mast #1	1	
—82	1271234	Channel - Mast #2	1	
—83	1271235	Channel - Mast #3 and #4	2	
—84	1271236	Channel - Mast #5	1	
—85	1260303	Chain Assembly - #466 Chain (See Items 101-106 for Breakdown)	2	
—86	1260304	Chain Assembly - #444 Chain (See Items 201-208 for Breakdown)	1	
—87	1060547	Cable Assembly (Prior to S/N 11459)	4	
	1060654	Cable Assembly (S/N 11459 to Present)	4	
—88	1683200	Lift Cylinder Assembly (See Section 5 for Breakdown)	1	
	0800926	MAST ASSEMBLY - 36 FT (VARIABLE PARTS)	Ref.	8
—81	1271226	Channel - Mast #1	1	
—82	1271227	Channel - Mast #2	1	
—83	1271228	Channel - Mast #3 and #4	2	
—84	1271232	Channel - Mast #5	1	
—85	1260300	Chain Assembly - #466 Chain (See Items 101-106 for Breakdown)	2	
—86	1260301	Chain Assembly - #444 Chain (See Items 201-208 for Breakdown)	1	
—87	1060548	Cable Assembly (Prior to S/N 11459)	4	
	1060655	Cable Assembly (S/N 11459 to Present)	4	
—88	1683175	Lift Cylinder Assembly (See Section 5 for Breakdown)	1	

SECTION 10-3 MAST

SECTION 10 - 3 MAST

FIGURE & ITEM NO	PART NUMBER	DESCRIPTION	QTY.	REV.
10-3-2		MAST ASSEMBLIES - 30 FT. AND 36 FT. (CONTINUED)	Ref.	
	1260303	CHAIN ASSEMBLY - #466 CHAIN (30 FT. MAST)	Ref.	B
	1260300	CHAIN ASSEMBLY - #466 CHAIN (36 FT. MAST)	Ref.	B
-101	0561156	Block	1	
-102	1260299	Chain	A/R	
		30 Ft. Mast	7 Ft.	
		36 Ft. Mast	8.125 Ft.	
-103	3422346	Pin, Grooved (Prior to May 1995)	2	
	3422265	Pin (May 1995 to Present)	2	
	3450201	Pin, Cotter 1/16" x 1/2" (May 1995 to Present)	4	
-104	0561150	Block	1	
-105	4300111	Stud	1	
-106	0100019	Loctite #271 (Not Shown) (Prior to S/N 10998)	A/R	
	0100062	Loctite #RC680 (Not Shown) (S/N 10998 to Present)	A/R	
	1260304	CHAIN ASSEMBLY - #444 CHAIN (30 FT. MAST)	Ref.	B
	1260301	CHAIN ASSEMBLY - #444 CHAIN (36 FT. MAST)	Ref.	B
-201	0561159	Block	1	
-202	1260298	Chain	A/R	
		30 Ft. Mast	14 Ft.	
		36 Ft. Mast	16.25 Ft.	
-203	3422346	Pin, Grooved	2	
-204	0561151	Block	2	
-205	4300111	Stud	2	
-206	0100019	Loctite #271 (Not Shown) (Prior to S/N 10998)	A/R	
	0100062	Loctite #RC680 (Not Shown) (S/N 10998 to Present)	A/R	
-207	3422266	Pin (Prior to August 1994)	1	
	3422407	Pin (August 1994 to Present)	1	
-208	3450201	Pin, Cotter	2	

SECTION 10-3 MAST

FIGURE 10-3-3. MAST MOUNTED COMPONENTS.

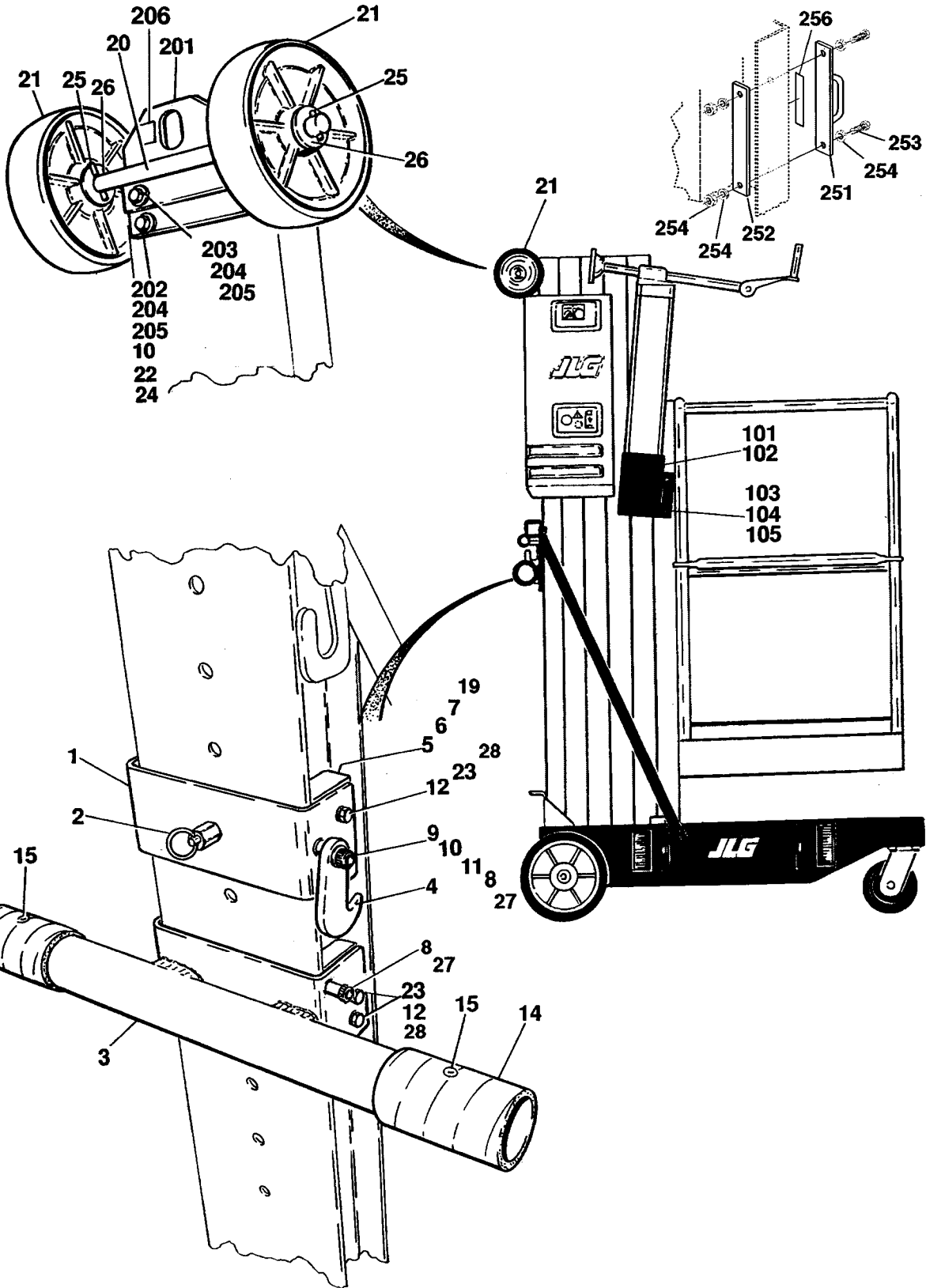

SECTION 10 - 3 MAST

SECTION 10-3 MAST

SECTION 10-3 MAST

FIGURE & ITEM NO	PART NUMBER	DESCRIPTION	QTY.	REV.
10-3-3		MAST MOUNTED COMPONENTS	Ref.	
		LOADING HARDWARE INSTALLATION (STANDARD PARTS)	Ref.	
-1	4844826	Support, Load Bar	1	
-2	3422369	Lockpin	1	
-3	4844796	Bar, Load	1	
-4	2700082	Hook	1	
-5	3340704	Pad, Slide	4	
-6	4070860	Shim 5/64"	2	
-7	4070861	Shim 1/32"	2	
-8	3900190	Bolt, Shoulder 3/8"-16NC x 1/2"	2	
-9	0961892	Bushing, Nylon	2	
-10	4751600	Flatwasher 3/8"	3	
-11	4711500	Flatwasher 5/16" Narrow	1	
-12	0641406	Bolt 1/4"-20NC x 3/4"	8	
-13	Not Used			
-14	2720130	Hose	2	
-15	3820024	Rivet	2	
-16	Not Used			
-17	Not Used			
-18	Not Used			
-19	3020035	Lubricant, Silicone (Not Shown)	A/R	
	0254842	LOADING HARDWARE INSTALLATION - 19 FT. AND 24 FT. MACHINES (VARIABLE PARTS)	Ref.	5
-20	4844921	Load Axle Weldment	1	
-21	4860152	Wheel Assembly	2	
	7012633	Bearing, Roller (1 Per Assembly)	2	
	7012634	Retainer, Bearing (2 Per Assembly)	4	
-22	0641608	Bolt 3/8"-16NC x 1"	2	
-23	4711400	Flatwasher 1/4" Narrow	8	
-24	3311605	Nut 3/8"-16NC	2	
-25	3450504	Rollpin 5/32" x 1"	4	
-26	4712200	Flatwasher 3/4" Narrow	4	
-27	0100011	Loctite #242	A/R	
-28	0100019	Loctite #271	A/R	
	0254951	LOADING HARDWARE INSTALLATION - 30 FT. AND 36 FT. MACHINES (VARIABLE PARTS)	Ref.	4
-20 to -26	Not Required			
-27	0100011	Loctite #242	A/R	
-28	0100019	Loctite #271	A/R	

SECTION 10-3 MAST

SECTION 10-3 MAST

FIGURE & ITEM NO	PART NUMBER	DESCRIPTION	QTY.	REV.
10-3-3		MAST MOUNTED COMPONENTS (CONTINUED)	Ref.	
	0254816	OUTRIGGER STOWAGE INSTALLATION	Ref.	D
-101		Stowage Rack Weldment (Left Side) Options:	1	
	4844810	Prior to May 1995		
	4845029	May 1995 to Present		
-102		Stowage Rack Weldment (Right Side) Options:	1	
	4844811	Prior to May 1995		
	4845030	May 1995 to Present		
-103	0641608	Bolt 3/8"-16NC x 1"	4	
-104	3311605	Locknut 3/8"-16NC	4	
-105	4711600	Flatwasher 3/8" Narrow	8	
	0255018	OPTIONAL CRANE HOOK INSTALLATION - 19 FT. AND 24 FT. MACHINES	Ref.	B
-201	3538591	Plate, Crane Hook	1	
-202	0641611	Bolt 3/8"-16NC x 1 3/8"	2	
-203	Not Used			
-204	4711600	Flatwasher 3/8" Narrow	2	
-205	3311601	Nut 3/8"-16NC	2	
-206	1701500	Decal (Prior to S/N 10781)	1	
	1703455	Decal (S/N 10781 to Present)	1	
	0255019	OPTIONAL CRANE HOOK INSTALLATION - 30 FT. AND 36 FT. MACHINES	Ref.	C
-201	3538591	Plate, Crane Hook	1	
-202	Not Used		2	
-203	0641609	Bolt 3/8"-16NC x 1 1/8"	4	
-204	4711600	Flatwasher 3/8" Narrow	4	
-205	3311601	Nut 3/8"-16NC	4	
-206	1701500	Decal (Prior to S/N 10781)	1	
	1703455	Decal (S/N 10781 to Present)	1	
	0256559	SAFETY ATTACH INSTALLATION	Ref.	B
-251	4845345	Weldment, Safety Attach	1	
-252	3539814	Plate	1	
-253	0681812	Bolt 1/2"-13UNC x 1 1/2"	2	
-254	3271805	Locknut 1/2"-13UNC	2	
-255	4751800	Flatwasher 1/2"	4	
-256	1702612	Decal - Lanyard Attach (Not Shown)	1	

SECTION 10-4 PLATFORM

TABLE OF CONTENTS

FIGURE NO.	DESCRIPTION	PAGE NO.
10-4-1	Platform Component Installations.....	10-4-2
10-4-2	Fiberglass Platform Installation	10-4-4

**S
E
C
T
I
O
N

1
0
-
4

P
L
A
T
F
O
R
M**

SECTION 10-4 PLATFORM

FIGURE 10-4-1. PLATFORM COMPONENT INSTALLATIONS.

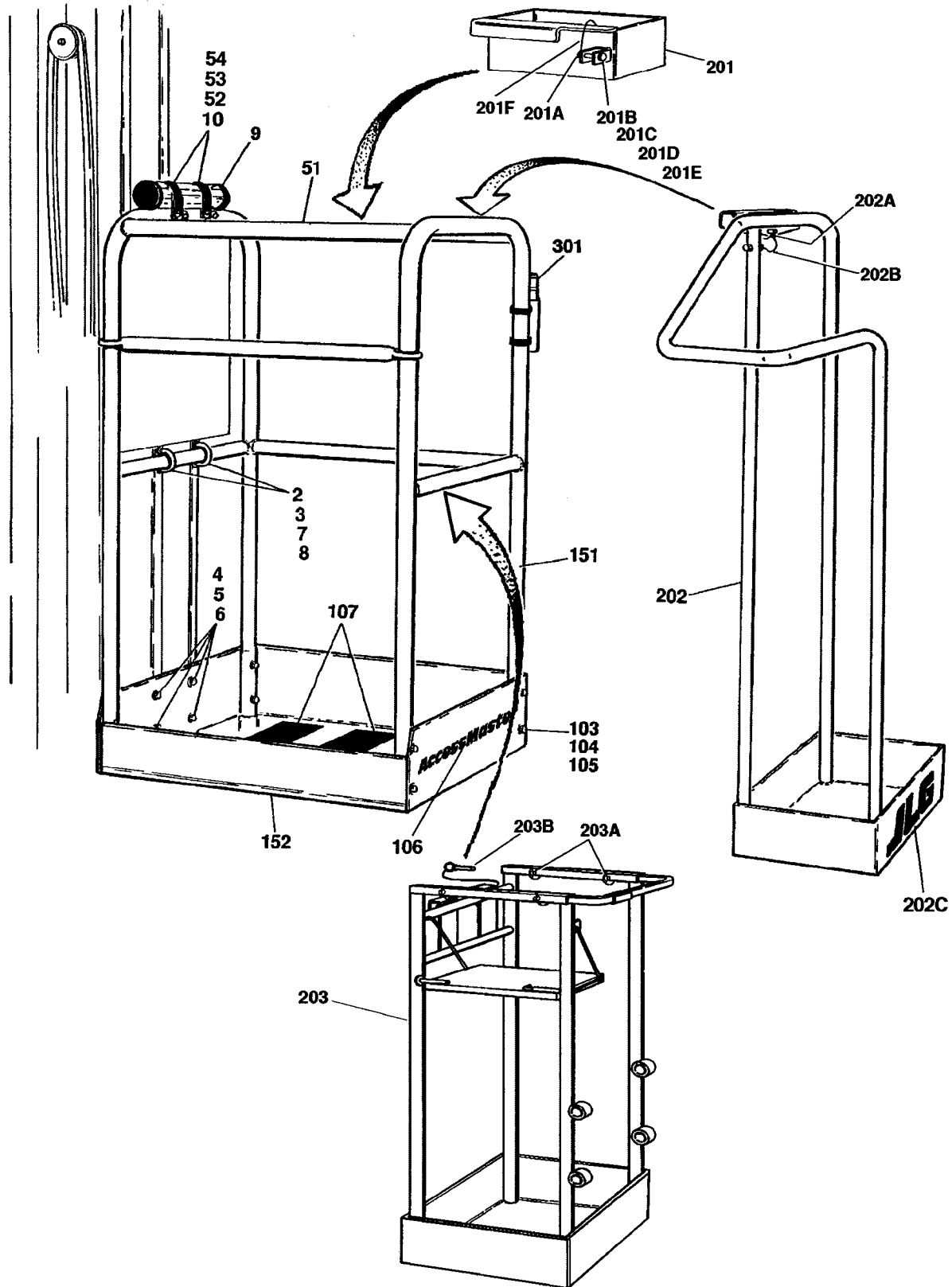

SECTION 10-4 PLATFORM

SECTION 10-4 PLATFORM

FIGURE & ITEM NO	PART NUMBER	DESCRIPTION	QTY.	REV.
10-4-1		PLATFORM COMPONENT INSTALLATIONS	Ref.	
		ALUMINUM PLATFORM INSTALLATION (STANDARD PARTS)	Ref.	
—1	Not Used			
—2	1320211	U-Bolt	2	
—3	4711500	Flatwasher 5/16" Narrow	4	
—4	0641408	Bolt 1/4"-20NC x 1"	4	
—5	4711400	Flatwasher 1/4"	8	
—6	3311405	Lock Nut 1/4"-20NC	4	
—7	3311501	Nut 5/16"-18NC	4	
—8	0100011	Loctite #242 (Not Shown)	A/R	
—9		Manual Tube Options:	1	
	4566563	Prior to May 1995		
	4566780	May 1995 to Present		
—10		Tube Clamp Options:	2	
	1320110	Prior to May 1995		
	1320219	May 1995 to Present		
	0254880	ALUMINUM PLATFORM INSTALLATION - 22" x 22" (VARIABLE PARTS)	Ref.	B
—51	3510472	Platform Weldment - 22" x 22"	1	
—52	3900215	Screw, Socket Head 1/4"-20NC x 1"	2	
—53	4751400	Flatwasher 1/4"	2	
—54	3311401	Nut 1/4"-20NC	2	
	0254879	ALUMINUM PLATFORM INSTALLATION - 26" x 26" (VARIABLE PARTS)	Ref.	C/3
—51	3510471	Platform Weldment - 26" x 26"	1	
—52	0640486	Screw, Socket Head 5/16"-18NC x 1"	2	
—53	4751500	Flatwasher 5/16"	2	
—54	3311505	Nut 5/16"-18NC	2	
		PLATFORM ASSEMBLIES (STANDARD PARTS)	Ref.	
—101	Not Used			
—102	Not Used			
—103	0641414	Bolt 1/4"-20NC x 1 3/4"	8	
—104	4751400	Flatwasher 1/4"	16	
—105	3311405	Locknut 1/4"-20NC	8	
—106	1702412	Decal, ACCESSMASTER	1	
—107	4420039	Tape, Non-Skid	A/R	
—108	1701612	Decal, JLG	1	
	3510472	PLATFORM ASSEMBLY - 22" x 22"	Ref.	D
—151	3640969	Rail Weldment	1	
—152	3538105	Plate, Bottom	1	
	3510471	PLATFORM ASSEMBLY - 26" x 26"	Ref.	D
—151	3640966	Rail Weldment	1	
—152	3537698	Plate, Bottom	1	

SECTION 10 - 4 PLATFORM

SECTION 10-4 PLATFORM

SECTION 10 - 4 PLATFORM

FIGURE & ITEM NO	PART NUMBER	DESCRIPTION	QTY.	REV.
10-4-1		PLATFORM COMPONENTS INSTALLATION (CONTINUED)	Ref.	
		OPTIONAL PLATFORM ATTACHMENTS	Ref.	
-201	0255036	Tool Tray Assembly	1	—
-201A	0902079	Bracket, Mounting	1	
-201B	3421453	Pin, Snap	1	
-201C	3900204	Bolt, Carriage #10 - 24 NC x 1/2"	2	
-201D	3300391	Nut, Wing #10 - 24 NC	2	
-201E	3760170	Ring, Split	1	
-201F	1060380	Cable, Lanyard	1	
-201G	1702365	Decal - JLG	1	
-202	0255040	Tube Caddy Assembly	1	—
-202A	3421453	Pin, Snap	1	
-201B	1060380	Cable, Lanyard	1	
-202C	1702365	Decal - JLG	1	
-203	0256683	Utility Caddy Assembly	1	—
-203A	3421453	Pin, Snap	2	
-203B	3422551	Pin, Hitch	2	
-204		Decal - Caddy Placement Options (Not Shown)	1	
	1703088	English		
	1703123	Japanese		
	1703117	Latin America Spanish		
	1703643	Brazil		
-205		Decal - Capacity Options (Not Shown)	1	
	1703087	English		
	1703122	Japanese		
	1703116	Latin America Spanish		
	1703642	Brazil		
	0255584	LASER LOCATOR INSTALLATION (PRIOR TOMAY 1995)	Ref.	—
-301	2920127	Pointer, Laser	1	
	4845016	Mounting Weldment	1	
	1320218	Clamp, Spring	2	
	0255853	LASER LOCATOR INSTALLATION (MAY 1995 TO PRESENT)	Ref.	A
-301	4656847	Tube, Mounting	1	
	1320218	Clamp, Spring	2	
	0750802	Screw #8 x 1/4"	2	
	2920127	Pointer, Laser	1	
	4460612	Connector, Strain Relief (Prior to S/N 10321)	1	
	4460425	Connector, Strain Relief (S/N 10321 to Present)	1	

SECTION 10-4 PLATFORM

FIGURE 10-4-2. FIBERGLASS PLATFORM INSTALLATION.

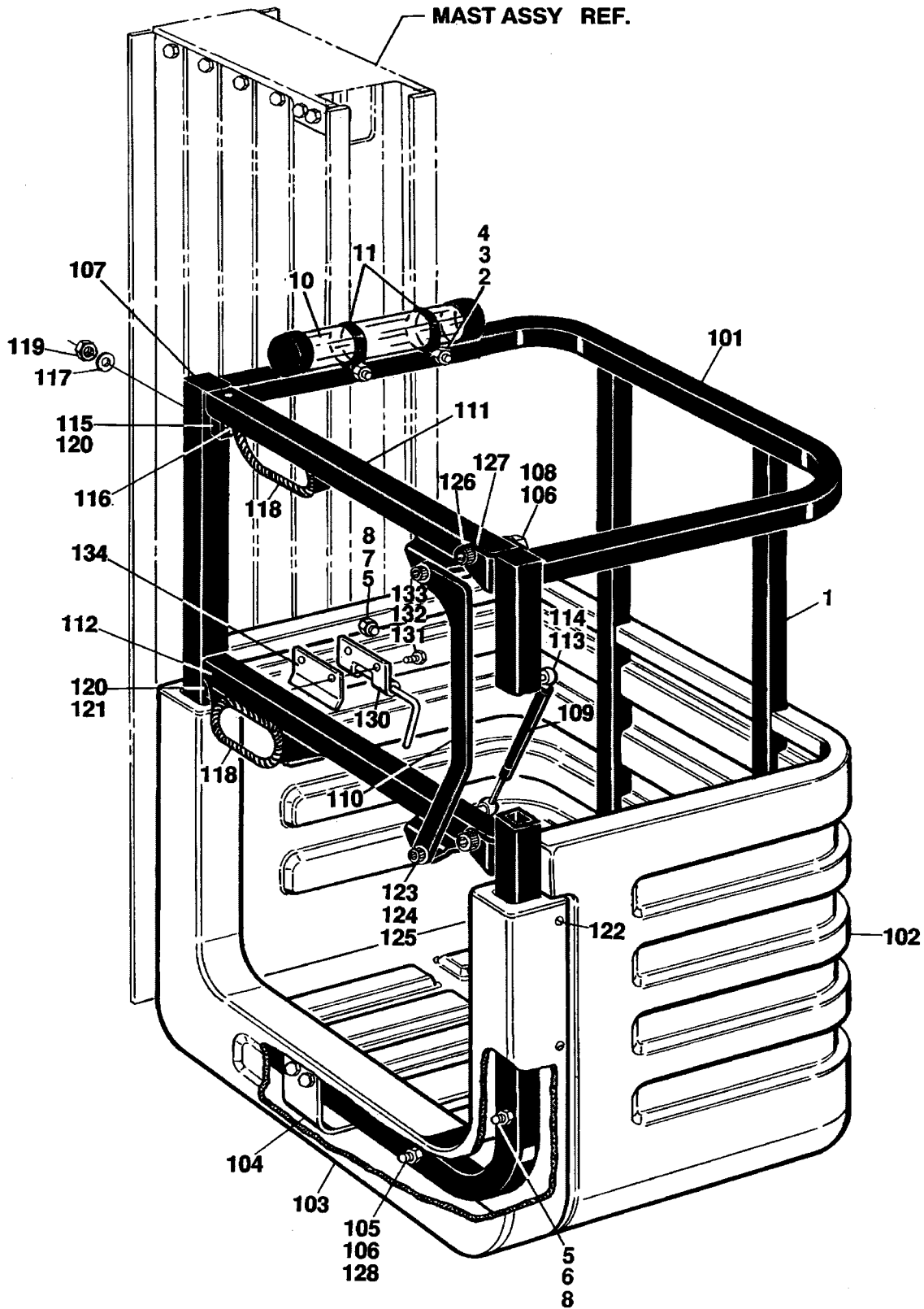

SECTION 10-4 PLATFORM

SECTION 10-4 PLATFORM

FIGURE & ITEM NO	PART NUMBER	DESCRIPTION	QTY.	REV.
10-4-2		FIBERGLASS PLATFORM INSTALLATION	Ref.	
	0254980	PLATFORM INSTALLATION	Ref.	B
—1	3510454	Platform Assembly (See Item 101-134 for Breakdown)	1	
—2	0641518	Bolt 5/16"-18NC x 2 1/4"	2	
—3	4711500	Flatwasher 5/16"	4	
—4	3311505	Locknut 5/16"-18NC	2	
—5	3300356	Nut 5/16"-18NC	2	
—6	0100019	Loctite #271 (Not Shown)	A/R	
—7	4300115	Stud 5/16"-18NC x 3"	2	
—8	3311501	Nut 5/16"-18NC	2	
—9	0100011	Loctite #242 (Not Shown)	A/R	
—10	4566563	Tube, Manual (Prior to May 1995)	1	
	4566780	Tube, Manual (May 1995 to Present)	1	
—11	1320110	Clamp, Tube (Prior to May 1995)	2	
	1320219	Clamp, Tube (May 1995 to Present)	2	
	3510454	PLATFORM ASSEMBLY	Ref.	4
—101	3640923	Rail	1	
—102	3510477	Basket	1	
—103	4060882	Cover	1	
—104	0362384	Bar, Support	1	
—105	0641416	Bolt 1/4"-20NC x 2"	10	
—106	4751400	Flatwasher 1/4"	22	
—107	3520072	Cap	2	
—108	3311405	Locknut 1/4"-20NC	12	
—109	4160125	Spring, Gas	1	
—110	0362347	Link, Gate	1	
—111	3640924	Rail, Gate (Top)	1	
—112	3640990	Rail, Gate (Bottom)	1	
—113	4751500	Flatwasher 5/16"	1	
—114	3311501	Nut 5/16"-18NC (Prior to S/N 11313)	1	
	3311505	Locknut 5/16"-18NC (S/N 11313 to Present)	1	
—115	3340746	Pad, Gate Rest	1	
—116	3911032	Screw, Machine #10-24NC x 2"	4	
—117	4751000	Flatwasher #10	8	
—118	4060804	Flex-Trim (Prior to S/N 11313)	2 Ft.	
	4060803	Flex-Trim (S/N 11313 to Present)	2 Ft.	
—119	3311001	Nut #10-24NC	4	
—120	4070890	Shim, Gate Stop	2	
—121	3340754	Pad, Gate Latch	1	
—122	3900177	Screw, Plastite	6	
—123	3900202	Bolt, Shoulder 1/4" x 1/4"	2	
—124	4740429	Washer, Nylon	4	
—125	3311005	Locknut #10-24NC	2	
—126	3900203	Bolt, Shoulder 5/16" x 1 1/2"	2	
—127	4740428	Washer, Nylon	4	
—128	3300151	Nut, Acorn 1/4"-20NC	2	
—129	0100011	Loctite #242 (Not Shown)	A/R	
—130	2940082	Latch, Gate	1	
—131	4750800	Flatwasher #8 (Prior to S/N 10321)	2	
—132	3310805	Locknut #8-32NC (Prior to S/N 10321)	2	
—133	3910808	Screw, Machine #8-32NC (Prior to S/N 10321)	2	
	3820024	Rivit 3/16 x 5/8" (S/N 10321 to Present)	2	
—134	4070894	Shim, Gate Latch	1	

SECTION 10-4 PLATFORM

SECTION 10-5 CYLINDERS

TABLE OF CONTENTS

FIGURE NO.	DESCRIPTION	PAGE NO.
10-5-1	Lift Cylinder Assembly (Standard Parts)	10-5-2

**S
E
C
T
I
O
N

1
0
-
5

C
Y
L
I
N
D
E
R
S**

SECTION 10-5 CYLINDERS

FIGURE 10-5-1. LIFT CYLINDER ASSEMBLY (STANDARD PARTS).

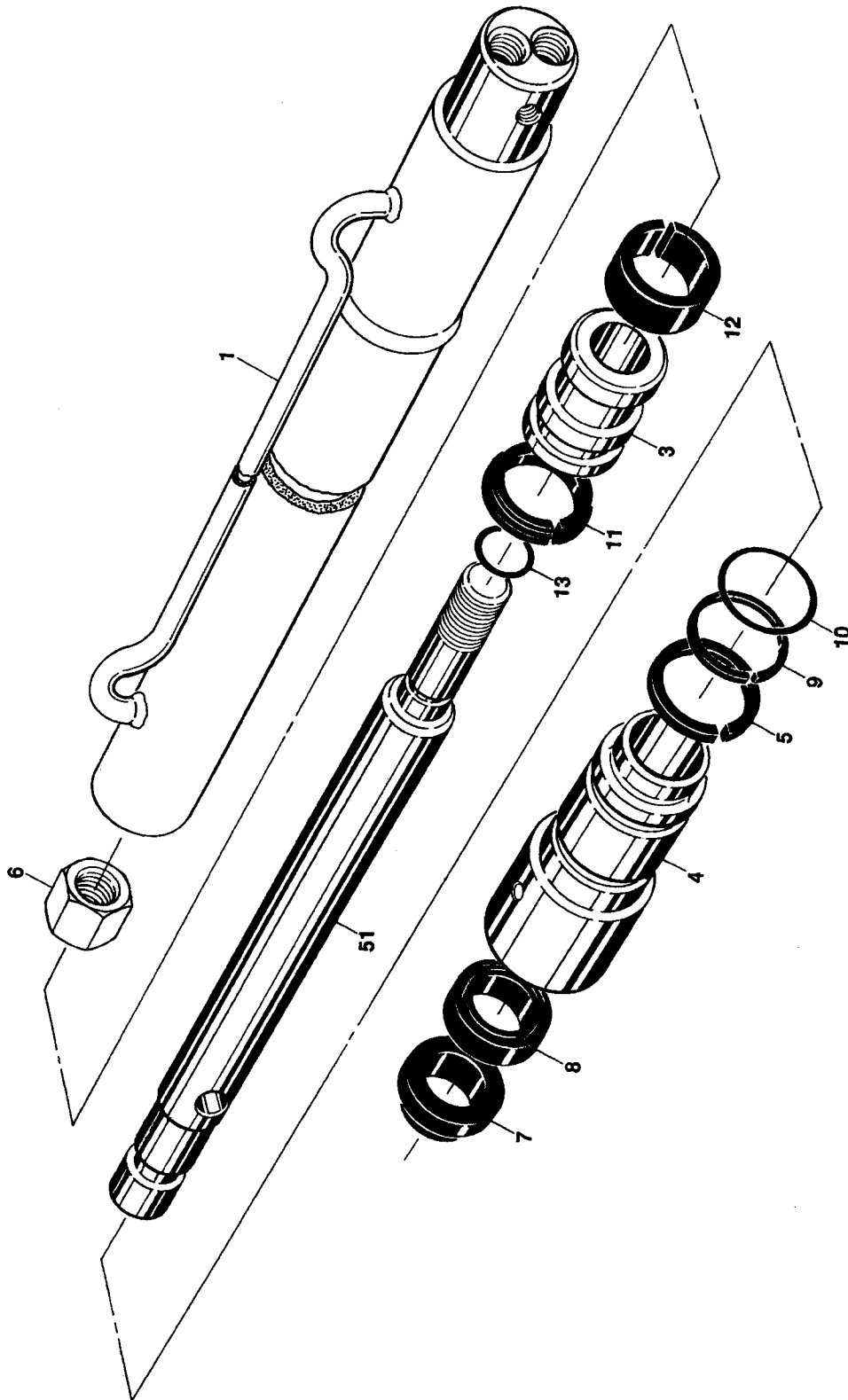

SECTION 10-5 CYLINDERS

SECTION 10-5 CYLINDERS

FIGURE & ITEM NO	PART NUMBER	DESCRIPTION	QTY.	REV.
10-5-1		LIFT CYLINDER ASSEMBLY (STANDARD PARTS)	Ref.	
—1	Not Serviced	Barrel	1	
—2	Not Used			
—3	7003249	Piston	1	
—4	7003248	Head	1	
—5	7003247	Ring, Retaining	1	
—6	7003246	Locknut	1	
—7	Kit	Wiper, Rod	1	
—8	Kit	Seal, Rod	1	
—9	Kit	Ring, Back-up	1	
—10	Kit	O-Ring	1	
—11	Kit	Seal, Piston	1	
—12	Kit	Ring, Wear	1	
—13	Kit	O-Ring	1	
	7003245	Seal Kit (Includes Items 7-13)	1	
	1683201	LIFT CYLINDER ASSEMBLY - 19 FT. AND 24 FT. MACHINES (VARIABLE PARTS)	Ref.	—
—51	7003250	Rod	1	
	1683200	LIFT CYLINDER ASSEMBLY - 30 FT. MACHINES (VARIABLE PARTS)	Ref.	—
—51	7003251	Rod	1	
	1683175	LIFT CYLINDER ASSEMBLY - 36 FT. MACHINES (VARIABLE PARTS)	Ref.	—
—51	7003252	Rod	1	

SECTION 10-5 CYLINDERS

SECTION 10-6 HYDRAULICS

TABLE OF CONTENTS

FIGURE NO.	DESCRIPTION	PAGE NO.
10-6-1	Hydraulic Diagram	10-6-2

**S
E
C
T
I
O
N

1
0
-
6

H
Y
D
R
A
U
L
I
C
S**

SECTION 10-6 HYDRAULICS

FIGURE 10-6-1. HYDRAULIC DIAGRAM.

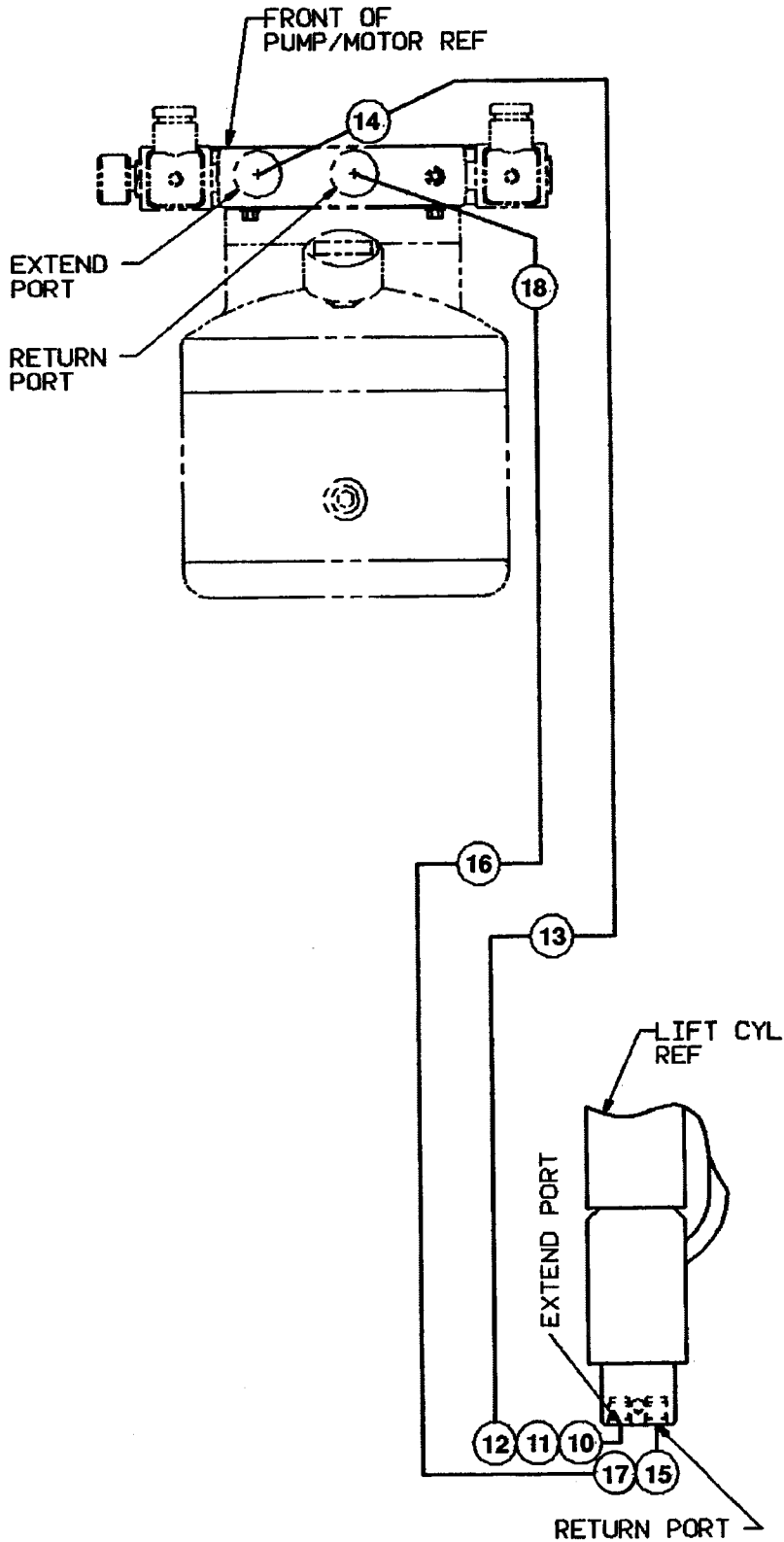

SECTION 10 - 6 HYDRAULICS

SECTION 10-6 HYDRAULICS

FIGURE & ITEM NO	PART NUMBER	DESCRIPTION	QTY.	REV.
10-6-1	0254808	HYDRAULIC DIAGRAM (AM-24/AM-30/AM-36)	Ref.	E
	0256274	HYDRAULIC DIAGRAM (AM-19)	Ref.	A/2
—10	2220875	Fitting, 90°	1	
—11	4640900	Valve, Flow Control	1	
—12	2220416	Fitting, 90°	1	
—13	4566559	Tube	1	
—14	2220472	Fitting, 90°	1	
—15	2220603	Fitting	1	
—16	4566558	Tube	1	
—17	2220507	Fitting, 90°	1	
—18	2220473	Fitting	1	
—19	0100020	Sealant, Pipe (Not Shown)	A/R	

SECTION 10-6 HYDRAULICS

SECTION 10-7 ELECTRICAL

TABLE OF CONTENTS

FIGURE NO.	DESCRIPTION	PAGE NO.
10-7-1	Electrical Diagrams and Components List	10-7-2
10-7-2	Electrical Diagram - 115VAC/60HZ	10-7-3
10-7-3	Electrical Diagram - 12VDC	10-7-4

**S
E
C
T
I
O
N
1
0
-
7
E
L
E
C
T
R
I
C
A
L**

SECTION 10-7 ELECTRICAL

FIGURE & ITEM NO	PART NUMBER	DESCRIPTION	QTY.	REV.
10-7-1		ELECTRICAL DIAGRAMS AND COMPONENTS LIST Note: Diagrams with asterisks (*) are shown in the following pages. Diagrams not shown are available from the JLG Service Department.	Ref.	
	4932715*	ELECTRICAL DIAGRAM - 115VAC/60HZ	Ref.	E
	4921661	Harness, Ground Control	1	
	4460044	Fuseholder	1	
	2400006	Fuse - 5 Amp	1	
	4932772	ELECTRICAL DIAGRAM - 115VAC/60HZ WITH FOOT-SWITCH (CORNING MACHINES)	Ref.	B
	4921663	Harness, Ground Control	1	
	4460044	Fuseholder	1	
	2400006	Fuse - 5 Amp	1	
	4932809	ELECTRICAL DIAGRAM - 115VAC/60HZ WITH FOOT-SWITCH (MACHINE WITH S/O#'s 26730 AND 26820-26824)	Ref.	A
	4921661	Harness, Ground Control	1	
	4460044	Fuseholder	1	
	2400006	Fuse - 5 Amp	1	
	4932716*	ELECTRICAL DIAGRAM -12VDC	Ref.	F
	1320210	Clamp	1	
	4460044	Fuseholder	1	
	2400006	Fuse - 5 Amp	1	
	0255569	ELECTRICAL DIAGRAM - DESCENT	Ref.	—
	0140033	Alarm	1	
	4932746	ELECTRICAL DIAGRAM - STRADDLE (OPTION)	Ref.	B
	4921728	Harness - Straddle	1	
	4932747	ELECTRICAL DIAGRAM - STRADDLE ADAPTOR (OPTION)	Ref.	C

SECTION 10-7 ELECTRICAL

SECTION 10-7 ELECTRICAL

FIGURE 10-7-2. ELECTRICAL DIAGRAM - 115VAC/60HZ.

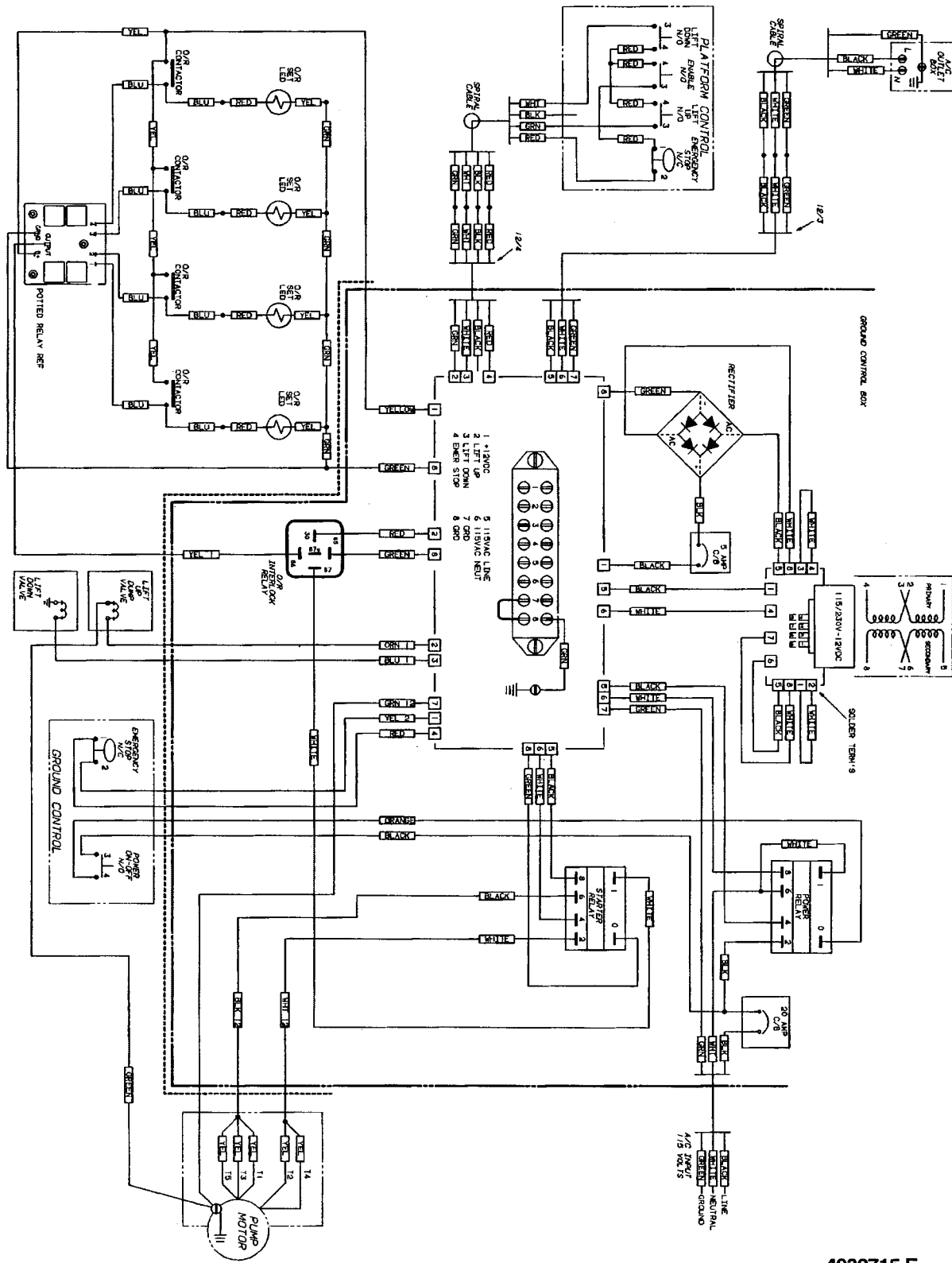

4932715 E

SECTION 10 - 7 ELECTRICAL

SECTION 10-7 ELECTRICAL

FIGURE 10-7-3. ELECTRICAL DIAGRAM - 12VDC.

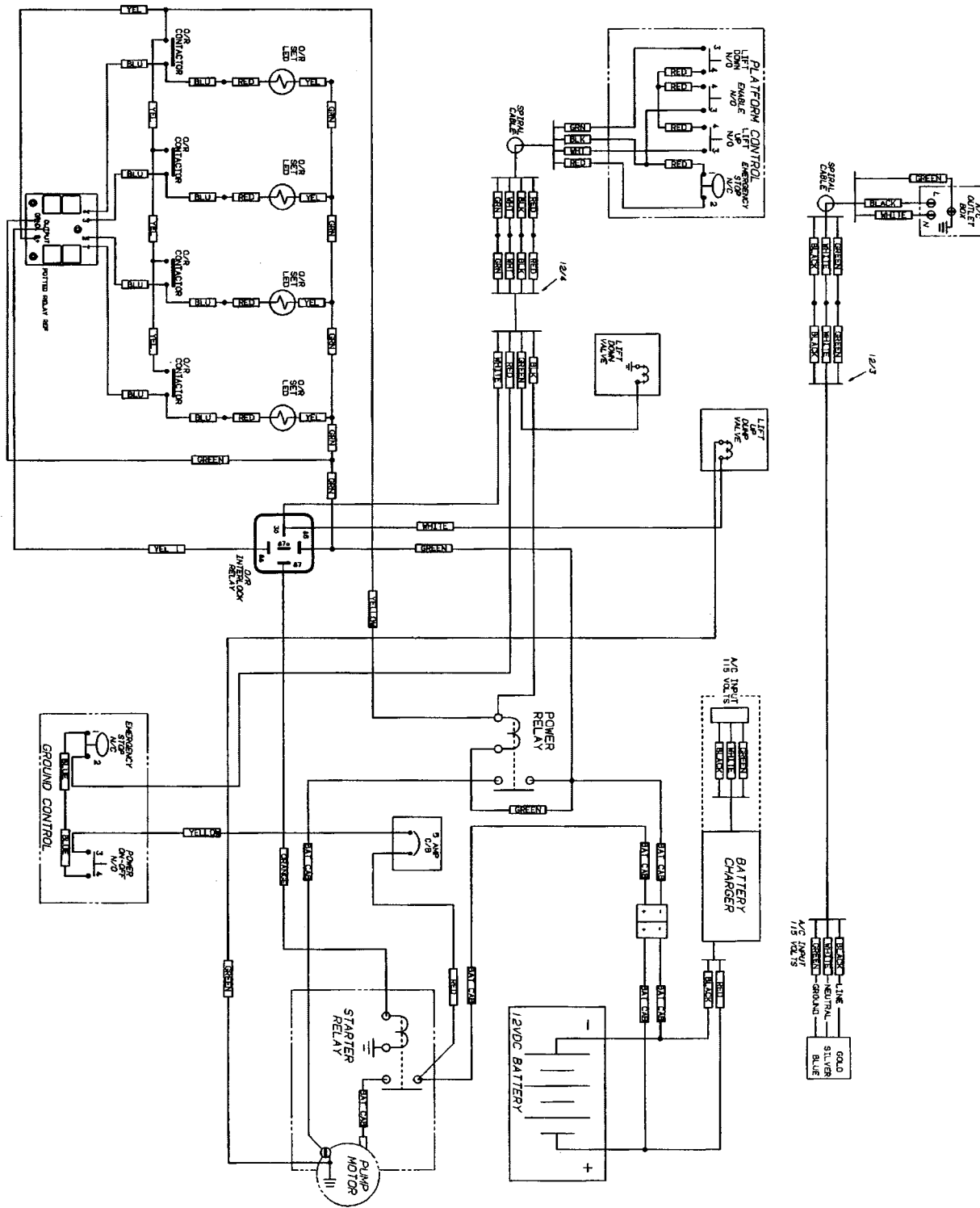

4932716 F

SECTION 10-7 ELECTRICAL

SECTION 10-8 DECALS

TABLE OF CONTENTS

FIGURE NO.	DESCRIPTION	PAGE NO.
8-1	Decals Installation	10-8-2

**S
E
C
T
I
O
N

1
0
-
8

D
E
C
A
L
S**

SECTION 10-8 DECALS

FIGURE 10-8-1. DECALS INSTALLATION.

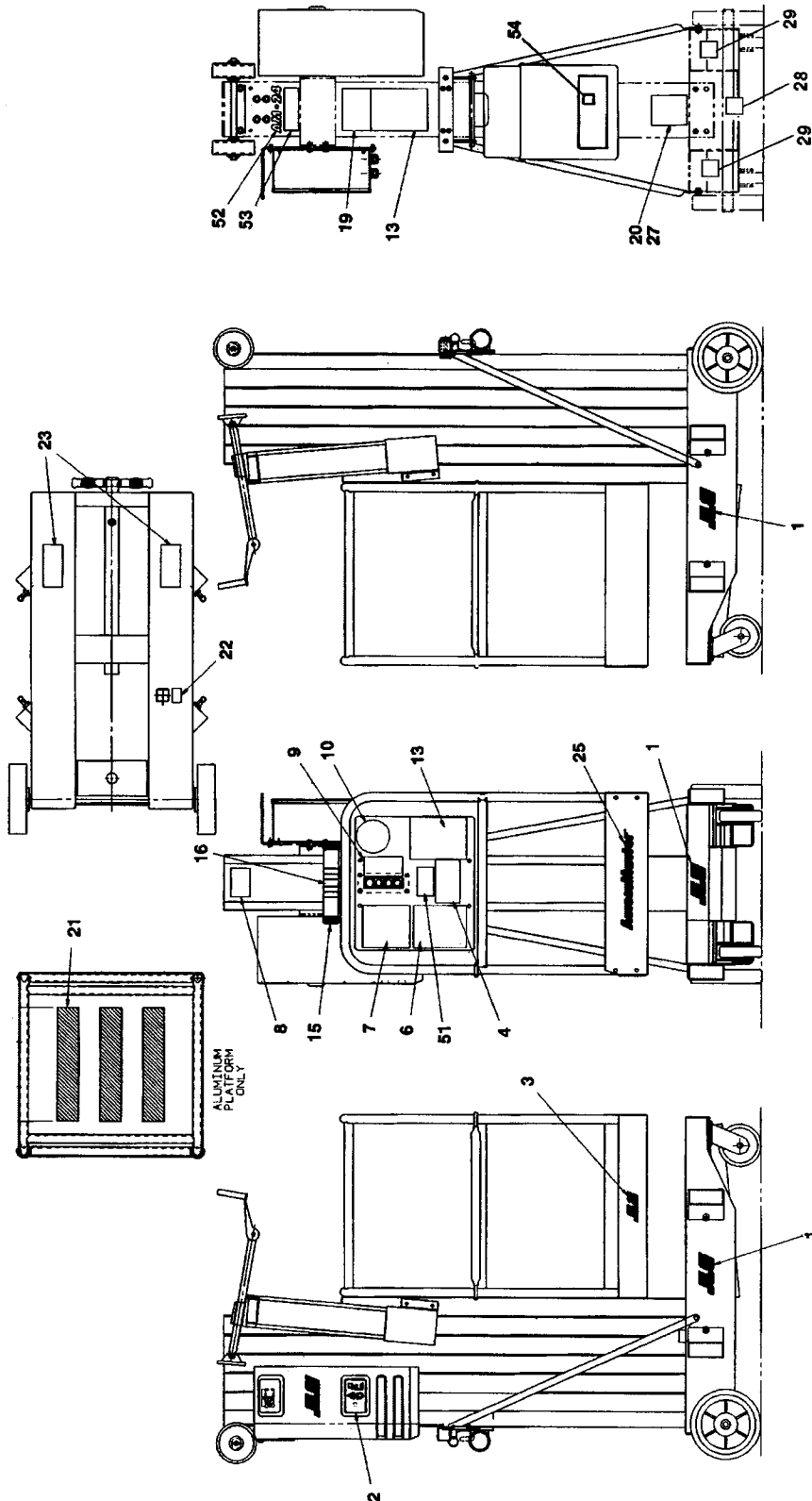

SECTION 10-8 DECALS

SECTION 10-8 DECALS

FIGURE & ITEM NO	PART NUMBER	DESCRIPTION	QTY.	REV.
10-8-1		DECALS INSTALLATIONS	Ref.	
	0254956	DECAL INSTALLATION - U.S.A/CSA (US STANDARDS)	Ref.	8
	0256735	DECAL INSTALLATION - U.S.A/CSA (METRIC)	Ref.	3
-1	1702365	Decal - JLG	3	
-2	Not Used			
-3	1701612	Decal - JLG	1	
-4	3252318	Decal - Tipping	1	
-5	Not Used			
-6	1702362	Decal - Caution	1	
-7	1702361	Decal - Electrical Hazard	1	
-8	1702391	Decal - Crushing (Prior to May 1995)	1	
	1703166	Decal - Crushing (S/N 10251 to S/N 10801)	1	
-9	1702360	Decal - Controls	1	
-10	3251813	Decal - USA	1	
-11 to -12	Not Used			
-13	1702413	Decal - Tipping and Crushing	2	
-14	Not Used			
-15		Tube, Package (See Section 10-4 For Installation)	1	
-16	1702110	Decal - Instructions	1	
-17 to -18	Not Used			
-19	1702363	Decal - Checklist	1	
-20	Consult Factory	Nameplate - Serial Number	1	
-21	4420039	Tape, Friction	A/R	
-22	1702109	Decal - Leveling	1	
-23	1702364	Decal - Crushing	2	
-24	Not Used			
-25	1702412	Decal - AccessMaster	1	
-26	Not Used			
-27	3820031	Rivet	4	
-28	1702631	Decal - Barcode (S/N 10251 to Present)	1	
-29	1703073	Decal - Forklift (S/N 11386 to Present)	2	
	0255562	DECAL INSTALLATION - LATIN AMERICA	Ref.	5
-1	1702365	Decal - JLG	3	
-2	Not Used			
-3	1701612	Decal - JLG	1	
-4	3252440	Decal - Tipping	1	
-5	Not Used			
-6	1702446	Decal - Caution	1	
-7	1702453	Decal - Electrical Hazard	1	
-8	1702459	Decal - Crushing (Prior to S/N 10321)	1	
	1703166	Decal - Crushing (Prior to S/N 10801)	1	
-9	1702463	Decal - Controls	1	
-10	3251813	Decal - USA	1	
-11 to -12	Not Used			
-13	1702467	Decal - Tipping and Crushing	2	
-14	Not Used			
-15		Tube, Package (See Section 10-4 For Installation)	1	
-16	1702473	Decal - Instructions	1	
-17 to -18	Not Used			
-19	1702479	Decal - Checklist	1	
-20	Consult Factory	Nameplate - Serial Number	1	
-21	4420039	Tape, Friction	A/R	
-22	1702486	Decal - Leveling	1	

SECTION 10 - 8 DECALS

SECTION 10-8 DECALS

FIGURE & ITEM NO	PART NUMBER	DESCRIPTION	QTY.	REV.
10-8-1		DECALS INSTALLATIONS (CONTINUED)	Ref.	
-23	1702492	Decal - Crushing	2	
-24	Not Used			
-25	1702412	Decal - AccessMaster	1	
-26	Not Used			
-27	3820031	Rivet	4	
-28	1702631	Decal - Barcode (S/N 10251 to Present)	1	
-29	1703073	Decal - Forklift (S/N 11386 to Present)	2	
	0257565	DECAL INSTALLATION - BRAZIL	Ref.	2
-1	1702365	Decal - JLG	3	
-2	Not Used			
-3	1701612	Decal - JLG	1	
-4	3253594	Decal - Tipping	1	
-5	Not Used			
-6	1703596	Decal - Caution	1	
-7	1703595	Decal - Electrical Hazard	1	
-8	Not Used			
-9	1702463	Decal - Controls	1	
-10	3251813	Decal - USA	1	
-11 to -12	Not Used			
-13	1703599	Decal - Tipping and Crushing	2	
-14 to -15	Not Used			
-16	1703592	Decal - Instructions	1	
-17 to -18	Not Used			
-19	1703597	Decal - Checklist	1	
-20	Consult Factory	Nameplate - Serial Number	1	
-21	4420039	Tape, Friction	A/R	
-22	1703591	Decal - Leveling	1	
-23	1703598	Decal - Crushing	2	
-24	Not Used			
-25	1702412	Decal - AccessMaster	1	
-26	Not Used			
-27	3820031	Rivet	4	
-28	1702631	Decal - Barcode (S/N 10251 to Present)	1	
-29	1703073	Decal - Forklift (S/N 11386 to Present)	2	
		DECAL INSTALLATION (VARIABLE)	Ref.	
-51		Decal - Capacity Options	1	
		Aluminum Platform		
	1703627	250 Lbs. Dom/CSA (AM-30)		
	1703241	350 Lbs. Dom/CSA (AM-19/AM-24/AM-30)		
	1702057	136 KG. Japanese (AM-36)		
	1702056	158 KG. Japanese (AM-19)		
	1703246	158 KG. Brazil/Latin America (AM-19/AM-24/AM-30)		
	1702508	158 KG./136 KG. Japanese (AM-24/AM-30)		
		Molded Platform		
	1702107	300 Lbs. Dom/CSA (AM-24/AM-30/AM-36)		
	1703245	136 KG. Brazil/Latin America (AM-24/AM-30/AM-36)		
	1702508	158 KG./136 KG. Japanese (AM-24/AM-30)		

SECTION 10 - 8 DECALS

SECTION 10-8 DECALS

FIGURE & ITEM NO	PART NUMBER	DESCRIPTION	QTY.	REV.
10-8-1		DECALS INSTALLATIONS (CONTINUED)	Ref.	
—52		Decal - Model Designation Options	1	
	1702408	AM-19		
	1702409	AM-24		
	1702410	AM-30		
	1702411	AM-36		
—53		Decal - Tilt Back Crushing (30 Ft. and 36 Ft. Machines)	1	
	1702415	U.S.A./CSA		
	1702519	Latin America		
	1702521	Japanese		
	1703600	Brazil		
—54		Decal Explosion (D.C. Units Only)	1	
	1702437	U.S.A./CSA		
	1702524	Latin America		
	1702527	Japanese		
	1703601	Brazil		

SECTION 10-9 RECOMMENDED SERVICE PARTS STOCK

AccessMaster

The following lists will service fleets of machines (built to current production per date on the front cover) with emergency repair parts which can be installed in the field. Parts from the list should be replaced when inventory is depleted to keep service parts stock supplied. For further information, contact you JLG dealer or the JLG Industries Parts Department.

SECTION 10-9 - RECOMMENDED SERVICE PARTS STOCK

JLG PART NO.	DESCRIPTION	QTY. PER FLEET SIZE		
		1-4	5-9	10 or More
STANDARD PARTS				
3740106	Relay, Potted (Figure 10-1-1)	1	1	1
7012635	Switch, Push/Pull Stop (Figure 10-2-1 and 10-2-4)	1	1	1
7012636	Switch, Key Lift (Figure 10-2-1 and 10-2-4)	1	1	1
7012640	Key, Replacement (Figure 10-2-1 and 10-2-4)	1	1	1
7013794	Filler/Breather Assembly (Figure 10-2-3 and 10-2-6)	1	1	1
7012638	Switch, Push Button (White) (Figure 10-2-7)	1	1	1
7012639	Switch, Push Button (Green) (Figure 10-2-7)	1	1	1
2400006	Fuse 5-Amp (Figure 10-7-1)	4	4	4
VARIABLE PARTS				
3740094	Relay, Starter - AC Units (Figure 10-2-2)	1	1	1
3740093	Relay, Starter - AC Units (Figure 10-2-2)	1	1	1
4360161	Breaker, Circuit - 20 Amp - AC Units (Figure 10-2-2)	1	1	1
4360376	Rectifier - AC Units (Figure 10-2-2)	1	1	1
3740049	Relay - AC Units (Figure 10-2-2)	1	1	1
4530010	Transformer - AC Units (Figure 10-2-2)	1	1	1
3740098	Relay, Thermal Overload - AC Units (Figure 10-2-2)	1	1	1
7013729	Coupling - AC Units (Figure 10-2-3)	1	1	1
3740080	Relay - DC Units (Figure 10-2-4)	1	1	1
3740013	Solenoid - DC Units (Figure 10-2-4)	1	1	1
7011509	Breaker, Circuit - DC Units (Figure 10-2-5)	1	1	1
7011559	Diode - 20 Amp - DC Units (Figure 10-2-5)	2	2	2
7013789	Solenoid Kit - DC Units (Figure 10-2-6)	1	1	1

SECTION 10-10 SPECIAL OPTIONS

TABLE OF CONTENTS

FIGURE NO.	DESCRIPTION	PAGE NO.
10-10-1	Miscellaneous Options List.....	10-10-1
10-10-2	Straddle Installation	10-10-2

FIGURE 10-10-1 MISCELLANEOUS OPTIONS LIST

Note: The following list is to accommodate machines with special equipment. Options may not be applicable to all models. For more specific information contact the JLG Parts Department.

PART NUMBER	DESCRIPTION	QTY
	MISCELLANEOUS OPTIONS LIST	Ref.
0255119	Adapter - Straddle Installation	Ref.
0255792	Battery/100-115VAC Charger Assembly Kit (Extra Reserve Pack)	Ref.
0255793	Battery/200-240VAC Charger Assembly Kit (Extra Reserve Pack)	Ref.
0256789	Camera Mount Assembly	Ref.
1670815	Cover - Travel/Storage	Ref.
	Japan Spec Installations	Ref.
0255268/1282302	Decal Installation	Ref.
1702057	Decal - Capacity	1
1702527	Decal - Explosion	1
1703166	Decal - Foot Pedal	1
1702521	Decal - Tilt Back Crushing	1
0255401	Power Unit Assembly	Ref.
0860977	Junction Box Assembly	1
3600244	Pump/Motor Assmby	1
4932784	Wiring Diagram	Ref.
	Logan Spec Installations	Ref.
1702416	Decal - Capacity	1
0801112	Mast Assembly (All Chain)	Ref.
2901510	Kit, Mast 24 ft.	1
0255814	Platform Installation with Footswitch	Ref.
4360404	Footswitch	1
4460428	Connector, Strain Relief	1

SECTION 10 - 10 SPECIAL OPTIONS

SECTION 10-10 SPECIAL OPTIONS

PART NUMBER	DESCRIPTION	QTY
	Special Tools:	Ref.
7002821	Crimper (For Wire to Pin/Socket Connections)	1
7002823	Extractor (For Removal of Pins/Sockets Connectors)	1
4460467	Extractor 16-18 Gauge (For Wire to Pin/Socket from Deutsch Connectors)	1
4460510	Extractor 12-14 Gauge (For Wire to Pin/Socket from Deutsch Connectors)	1
7016654	Screwdriver, Magnetic	1
7004275	Seal Tool - 1"	1
7004276	Seal Tool - 1 1/2"	1
7002826	Seal Tool - 2"	1
8896941	Stripper, Wire	1

SECTION 10 - 10 SPECIAL OPTIONS

SECTION 10-10 SPECIAL OPTIONS

FIGURE 10-10-2. STRADDLE INSTALLATION.

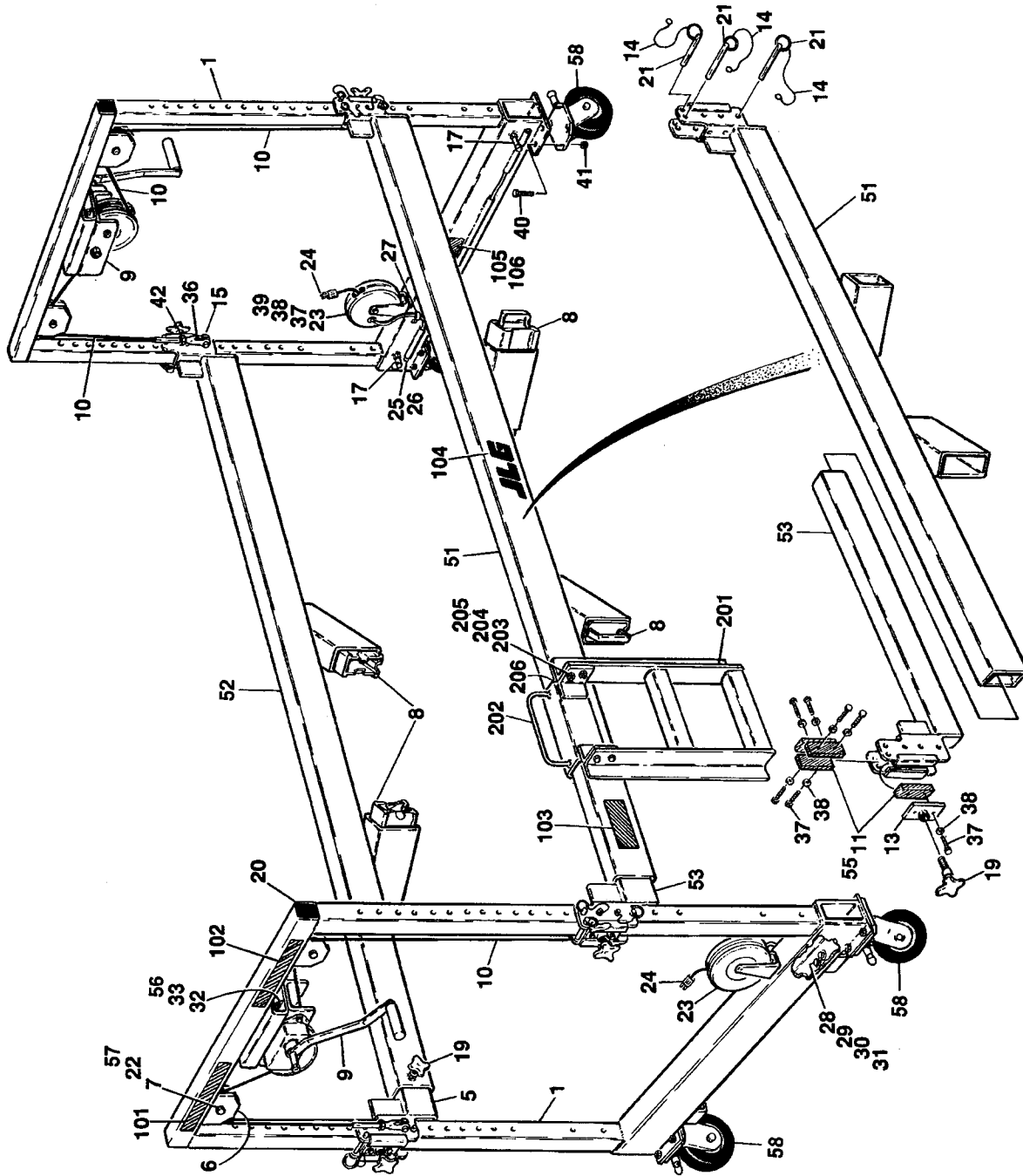

SECTION 10-10 SPECIAL OPTIONS

SECTION 10 - 10 SPECIAL OPTIONS

FIGURE & ITEM NO	PART NUMBER	DESCRIPTION	QTY.	REV.
10-10-2		STRADDLE INSTALLATIONS	Ref.	
		STRADDLE EXTENSION ASSEMBLY	Ref.	
—1	4844870	Weldment, Straddle Support	2	
—2	Not Used			
—3	Not Used			
—4	Not Used			
—5	Not Used			
—6	3580251	Pulley, Cable 3/16"	4	
—7	3900208	Bolt 3/8" x 1"	4	
—8	4844881	Weldment, Pup	4	
—9	4880041	Winch, Hand	2	
	7012659	Lining, Brake	4	
	7016621	Clamp, Rope	2	
	7012660	Handle	2	
—10	1060577	Cable, Lifting 7/32"	2	
—11	3340750	Pad, Slide	16	
—12	Not Used			
—13	3538371	Plate, Pad Support	4	
—14	1060380	Cable, Lanyard 10"	16	
—15	3421410	Pin, Quick Release 3/8" x 1"	4	
—16	4860143	Caster, 5" Swivel Locking	4	
	7012641	Wheel, Replacement	1	
	7012630	Kit, Axle	1	
	7012642	Bearing, Roller	1	
	7012631	Bearing, Spanner	1	
	7012628	Retainer	1	
	7012643	Spacers	2	
—17	3422369	Pin, Locking	4	
—18	Not Used			
—19	2560120	Knob, Locking	6	
—20	3520071	Plug, Square 2'	4	
—21	3421060	Pin, Quick Release 3/8" x 4"	12	
—22	4711500	Flatwasher 5/16"	4	
—23	3680052	Reel, Cord	2	
—24	4460205	Connector, Plug	2	
—25	2920121	Light, L.E.D.	4	
—26	3520162	Plug, LED Mounting	4	
—27	1320041	Clamp	2	
—28	3900194	Screw #8-32NC x 5/8" (Brass)	16	
—29	2540024	Grommet	16	
—30	3300379	Nut #8-32NC (Brass)	32	
—31	4740434	Washer #8 (Nylon)	48	
—32	0641608	Bolt 3/8"-16NC x 1"	6	
—33	4751600	Flatwasher 3/8"	12	
—34	Not Used			
—35	Not Used			
—36	1360266	Clevis, Cable	4	
—37	0641405	Bolt 1/4"-10NC x 5/8"	36	
—38	4711400	Flatwasher 1/4"	36	
—39	3311401	Nut 1/4"-20NC	4	
—40	0641608	Bolt 3/8"-16NC x 1"	16	
—41	3300380	Locknut 3/8"-16NC	16	
—42	3321602	Locknut 3/8"-24NC	4	

SECTION 10-10 SPECIAL OPTIONS

SECTION 10-10 SPECIAL OPTIONS

FIGURE & ITEM NO	PART NUMBER	DESCRIPTION	QTY.	REV.
10-10-2		STRADDLE INSTALLATIONS (CONTINUED)	Ref.	
	0255086	STRADDLE EXTENSION ASSEMBLY (PRIOR TO AUGUST 1995)	Ref.	D
—51		Base Tube Weldment Options:	1	
	4844872	Prior to July 1995		
	4845021	July 1995 to July 1995		
	4844872	July 1995 to Present		
—52		Base Tube Weldment Options:	1	
	4844875	Prior to July 1995		
	4845020	July 1995 to July 1995		
	4844875	July 1995 to Present		
—53		Base Extension Tube Weldment Options:	1	
	4844876	Prior to July 1995		
	4845022	July 1995 to July 1995		
	4844876	July 1995 to Present		
—54		Base Extension Tube Weldment Options:	1	
	4844877	Prior to July 1995		
	4845023	July 1995 to July 1995		
	4844877	July 1995 to Present		
—55	4070891	Shim	8	
—56	3311605	Locknut 3/8"-16NC	6	
—57	3315805	Locknut 5/16"-18NC	4	
—58	4860143	Caster, 5" Swivel Locking	4	
	7012641	Wheel, Replacement	1	
	7012630	Kit, Axle	1	
	7012642	Bearing, Roller	1	
	7012631	Bearing, Spanner	1	
	7012628	Retainer	1	
	7012643	Spacers	2	
	0255831	STRADDLE EXTENSION ASSEMBLY (PHENOLIC CASTERS) (VARIABLE PARTS) (AUGUST 1995 TO PRESENT)	Ref.	2
—51	4845021	Base Tube Weldment	1	
—52	4845020	Base Tube Weldment	1	
—53	4845022	Base Extension Tube Weldment	1	
—54	4845023	Base Extension Tube Weldment	1	
—55	4070891	Shim (Prior to S/N 10825)	8	
—56	3311605	Locknut 3/8"-16NC	6	
—57	3315805	Locknut 5/16"-18NC	4	
—58	4860143	Caster, 5" Swivel Locking	4	
	7012641	Wheel, Replacement	1	
	7012630	Kit, Axle	1	
	7012642	Bearing, Roller	1	
	7012631	Bearing, Spanner	1	
	7012628	Retainer	1	
	7012643	Spacers	2	

SECTION 10-10 SPECIAL OPTIONS

SECTION 10 - 10 SPECIAL OPTIONS

FIGURE & ITEM NO	PART NUMBER	DESCRIPTION	QTY.	REV.
10-10-2		STRADDLE INSTALLATIONS (CONTINUED)	Ref.	
	0257055	STRADDLE EXTENSION ASSEMBLY (POLYURETHANE CASTERS) (VARIABLE PARTS) (S/N 10825 TO PRESENT)	Ref.	2
—51	4845021	Base Tube Weldment	1	
—52	4845020	Base Tube Weldment	1	
—53	4845022	Base Extension Tube Weldment	1	
—54	4845023	Base Extension Tube Weldment	1	
—55	4070891	Shim (Prior to S/N 10825)	8	
—56	3311605	Locknut 3/8"-16NC	6	
—57	3315805	Locknut 5/16"-18NC	4	
—58	4860173	Caster, 5" Swivel Locking	4	
	0255243	DECAL INSTALLATION	Ref.	A
—101	1702434	Decal, Caution	2	
—102	1702435	Decal, Warning	2	
—103	1702436	Decal, Danger Extension	2	
—104	1702365	Decal, JLG	2	
—105	Consult Factory	Nameplate, Manufacturers	1	
—106	3820001	Rivet, Pop	4	
	0257110	DECAL INSTALLATION - JAPANESE	Ref.	—
—101	1703426	Decal, Caution	2	
—102	1703434	Decal, Warning	2	
—103	1703441	Decal, Danger Extension	2	
—104	1702365	Decal, JLG	2	
—105	Consult Factory	Nameplate, Manufacturers	1	
—106	3820001	Rivet, Pop	4	
	0257112	DECAL INSTALLATION - LATIN AMERICA	Ref.	—
—101	1703428	Decal, Caution	2	
—102	1703435	Decal, Warning	2	
—103	1703442	Decal, Danger Extension	2	
—104	1702365	Decal, JLG	2	
—105	Consult Factory	Nameplate, Manufacturers	1	
—106	3820001	Rivet, Pop	4	
	0255133	LADDER ASSEMBLY	Ref.	—
—201	4844897	Weldment, Ladder	1	
—202	4844901	Weldment, Ladder Attach	1	
—203	0641507	Bolt 5/16"-18NC x 7/8"	4	
—204	3300356	Nut 5/16"-18NC	4	
—205	4751500	Washer 5/16"	8	
—206	4280296	Strip, Wear	3.25 Ft.	



TRANSFER OF OWNERSHIP

To: JLG, Gradall, Lull and Sky Trak product owner:

If you now own, but ARE NOT the original purchaser of the product covered by this manual, we would like to know who you are. For the purpose of receiving safety-related bulletins, it is very important to keep JLG Industries, Inc. updated with the current ownership of all JLG products. JLG maintains owner information for each JLG product and uses this information in cases where owner notification is necessary.

Please use this form to provide JLG with updated information with regard to the current ownership of JLG Products. Please return completed form to the JLG Product Safety & Reliability Department via facsimile (717) 485-6573 or mail to address as specified on the back of this form.

Thank you,
Product Safety & Reliability Department
JLG Industries, Inc.
1 JLG Drive
McConnellsburg, PA 17233-9533
Telephone: (717) 485-5161
Fax: (717) 485-6573

NOTE: Leased or rented units should not be included on this form.

Mfg. Model: _____

Serial Number: _____

Previous Owner: _____

Address: _____

City: _____ State: _____

Zip: _____ Telephone: (_____) _____

Date Of Transfer: _____

Current Owner: _____

Address: _____

City: _____ State: _____

Zip: _____ Telephone: (_____) _____

Who in your organization should we notify?

Name: _____

Title: _____

Please cut on the dotted line and fax to 717-485-6573





Corporate Office
JLG Industries, Inc.
1 JLG Drive
McConnellsburg PA. 17233-9533
USA
Phone: (717) 485-5161
Customer Support Toll Free: (877) 554-5438
Fax: (717) 485-6417

JLG Worldwide Locations

JLG Industries (Australia)
P.O. Box 5119
11 Bolwarra Road
Port Macquarie
N.S.W. 2444
Australia
Phone: (61) 2 65 811111
Fax: (61) 2 65 810122

JLG Industries (UK)
Unit 12, Southside
Bredbury Park Industrial Estate
Bredbury
Stockport
SK6 2sP
England
Phone: (44) 870 200 7700
Fax: (44) 870 200 7711

JLG Deutschland GmbH
Max Planck Strasse 21
D-27721 Ritterhude/lhlpohl
Bei Bremen
Germany
Phone: (49) 421 693 500
Fax: (49) 421 693 5035

JLG Industries (Italia)
Via Po. 22
20010 Pregnana Milanese - MI
Italy
Phone: (39) 02 9359 5210
Fax: (39) 02 9359 5845

JLG Latino Americana Ltda.
Rua Eng. Carlos Stevenson,
80-Suite 71
13092-310 Campinas-SP
Brazil
Phone: (55) 19 3295 0407
Fax: (55) 19 3295 1025

JLG Europe B.V.
Jupiterstraat 234
2132 HJ Foofddorp
The Netherlands
Phone: (31) 23 565 5665
Fax: (31) 23 557 2493

JLG Industries (Norge AS)
Sofeimyrveien 12
N-1412 Sofienyr
Norway
Phone: (47) 6682 2000
Fax: (47) 6682 2001

JLG Polska
Ul. Krolewska
00-060 Warszawa
Poland
Phone: (48) 91 4320 245
Fax: (48) 91 4358 200

JLG Industries (Europe)
Kilmartin Place,
Tannochside Park
Uddingston G71 5PH
Scotland
Phone: (44) 1 698 811005
Fax: (44) 1 698 811055

JLG Industries (Pty) Ltd.
Unit 1, 24 Industrial Complex
Herman Street
Meadowdale
Germiston
South Africa
Phone: (27) 11 453 1334
Fax: (27) 11 453 1342

Plataformas Elevadoras
JLG Iberica, S.L.
Trapadella, 2
P.I. Castellbisbal Sur
08755Castellbisbal
Spain
Phone: (34) 93 77 24700
Fax: (34) 93 77 11762

JLG Industries (Sweden)
Enkopingsvagen 150
Box 704
SE - 175 27 Jarfalla
Sweden
Phone: (46) 8 506 59500
Fax: (46) 8 506 59534
