Illustrated Parts Manual

Models
100HX
110HX
100HX+10

3120801

July 29, 2011



An Oshkosh Truck Corporation Company

REVISION LOG

January 1991 - Original Issue Of Manual
February 1997 - Revised (New Format)
September 1997 - Change 1
October 29, 1999 - Revised (Manual edited to 0010375 Revision 41)
March 1, 2000 - Revised (Manual edited to 0010375 Revision 41)
October 1, 2000 - Revised (Manual edited to 0010375 Revision 42)
February 12, 2004 - Revised
January 2, 2008 - Revised
July 29, 2011 - Revised

REVISION LOG

TABLE OF CONTENTS

FIGURE NO.	TITLE	PAGE NO.
SECTION 1 - FRAME		1-1
1-1	STEERING AND AXLE/WHEEL DRIVE INSTALLATIONS	1-2
1-2	DRIVE HUB ASSEMBLY	1-6
1-3	DRIVE BRAKE ASSEMBLY - AUSCO	1-10
1-4	DRIVE BRAKE ASSEMBLY - MICO	1-12
1-5	DRIVE MOTOR ASSEMBLY - VICKERS	1-16
1-6	DRIVE MOTOR ASSEMBLY - SAUER-DANFOSS	1-20
1-7	VALVES AND SWITCHES INSTALLATIONS (FRAME MOUNTED)	1-22
1-8	TOW PACKAGE INSTALLATIONS	1-26
SECTION 2 - TURNTABLE		2-1
2-1	TURNTABLE, BOOM AND CUTOUT SWITCH INSTALLATIONS (4620044 TURNTABLE MACHINES)	2-2
2-2	TURNTABLE, BOOM AND CUTOUT SWITCH INSTALLATIONS (4620078 TURNTABLE MACHINES)	2-6
2-3	CONTROL VALVES AND TILT INDICATOR INSTALLATIONS	2-10
2-4	CONTROL VALVES ASSEMBLY (VICKERS) (PRIOR TO OCTOBER 1994)	2-14
2-5	CONTROL VALVES ASSEMBLY (VICKERS) (OCTOBER 1994 TO PRESENT)	2-18
2-6	CONTROL VALVE ASSEMBLY - BANG-BANG WITH DUMP SECTION (PRIOR TO JUNE 1995)	2-22
2-7	CONTROL VALVE ASSEMBLY - BANG-BANG WITH DUMP SECTION (JUNE 1995 TO PRESENT)	2-26
2-8	ACCESSORY VALVE ASSEMBLY (MILLER) (MACHINES BUILT THROUGH 1989)	2-30
2-9	ACCESSORY VALVE ASSEMBLY (MACHINES BUILT 1990 TO PRESENT)	2-32
2-10	CONTROL VALVE ASSEMBLY - 1 SECTION BANG-BANG (100HX+10/110HXER MACHINES)	2-34
2-11	SWING DRIVE, BEARING AND LOCK INSTALLATIONS	2-36
2-12	SWING MOTOR ASSEMBLY - NICHOLS	2-38
2-13	SWING BRAKE ASSEMBLY (PRIOR TO APRIL 1992)	2-40
2-14	SWING BRAKE ASSEMBLY (APRIL 1992 to PRESENT)	2-44
2-15	SWING HUB ASSEMBLY	2-48
2-16	ROTARY COUPLING AND COLLECTOR RING ASSEMBLY AND INSTALLATION	2-50
2-17	DEUTZ ENGINE INSTALLATION WITHOUT NOISE REDUCTION (BUILT PRIOR TO OCTOBER 1992)	2-54
2-18	DEUTZ ENGINE INSTALLATION WITH NOISE REDUCTION (BUILT OCTOBER 1992 TO PRESENT)	2-60
2-19	ADECO THROTTLE COMPONENTS INSTALLATION - DEUTZ ENGINE MACHINES	2-68
2-20	GENERATOR INSTALLATIONS - DEUTZ ENGINE MACHINES	2-70
2-21	PUMP COUPLING INSTALLATION	2-72
2-22	MAIN PUMP ASSEMBLY	2-74
2-23	TANKS INSTALLATION	2-76
2-24	GROUND CONTROLS INSTALLATION	2-80
2-25	LOAD MANAGEMENT INSTALLATION	2-86
2-26	HOODS AND ALARM INSTALLATION (MACHINES WITH 4620044 TURNTABLE)	2-88
2-27	HOODS AND ALARM INSTALLATION (MACHINES WITH 4620078 TURNTABLE)	2-92
SECTION 3 - BOOM		3-1
3-1	BOOM ASSEMBLY COMPONENTS INSTALLATION	3-2
3-1	BOOM ASSEMBLY COMPONENTS INSTALLATION (SHEET 2 OF 2)	3-3
3-2	CHAIN ADJUSTER ASSEMBLIES	3-14

TABLE OF CONTENTS

FIGURE NO.	TITLE	PAGE NO.
3-3	EXTEND-A-REACH INSTALLATIONS (PRIOR TO MAY 1992) (100HX+10 & 110HXER ONLY)	3-18
3-4	EXTEND-A-REACH INSTALLATIONS (MAY 1992 TO PRESENT) (100HX+10 & 110HXER ONLY)	3-22
3-5	BOOM LENGTH INDICATOR AND LIMIT SWITCHES INSTALLATION	3-24
3-6	BROKEN CHAIN LIMIT SWITCH INSTALLATION (GERMAN/AUSTRIAN SPECS BUILT PRIOR TO S/N 28224)	3-28
3-7	BOOM WIPERS INSTALLATION	3-30
SECTION 4 - PLATFORMS		4-1
4-1	PLATFORM COMPONENTS INSTALLATION - 100HX/110HX	4-2
4-2	PLATFORM COMPONENTS INSTALLATION - 100HX+10/110HXER (PRIOR TO MAY 1992)	4-6
4-3	PLATFORM COMPONENTS INSTALLATION - 100HX+10/110HXER (MAY 1992 TO PRESENT)	4-10
4-4	ROTATOR MOTOR ASSEMBLY	4-14
4-5	CONSOLE BOX ASSEMBLY (PRIOR TO SEPTEMBER 1991)	4-16
4-6	CONSOLE BOX ASSEMBLY (SEPTEMBER 1991 TO PRESENT)	4-20
4-7	CONTROLLER ASSEMBLIES - OEM	4-26
4-8	OPTIONAL COMMON PLATFORM MOUNTED COMPONENTS	4-28
SECTION 5 - CYLINDER		5-1
5-1	AXLE EXTENSION CYLINDER ASSEMBLY	5-2
5-2	AXLE LIFT CYLINDER ASSEMBLY	5-4
5-3	LEVEL CYLINDER ASSEMBLY (100HX & 110HX BUILT PRIOR TO MAY 1992)	5-6
5-4	LEVEL CYLINDER ASSEMBLY (100HX & 110HX)	5-8
5-5	LEVEL CYLINDER ASSEMBLY (100HX+10 & 110HXER BUILT PRIOR TO MAY 1992)	5-10
5-6	LEVEL CYLINDER ASSEMBLY (100HX+10 & 110HXER)	5-12
5-7	LIFT CYLINDER ASSEMBLY - BOOM (PRIOR TO MAY 1992)	5-14
5-8	LIFT CYLINDER ASSEMBLY - BOOM (MAY 1992 TO PRESENT)	5-16
5-9	LIFT CYLINDER ASSEMBLY - BOOM (GERMAN TUV STYLE)	5-18
5-10	LIFT CYLINDER ASSEMBLY - EXTEND-A-REACH (100HX+10 & 110HXER ONLY)	5-20
5-11	MASTER CYLINDER ASSEMBLY	5-22
5-12	STEER CYLINDER ASSEMBLY	5-24
5-13	TELESCOPE CYLINDER ASSEMBLIES	5-26
5-14	CYLINDER BELLOWS INSTALLATION	5-30
SECTION 6 - HYDRAULICS		6-1
6-1	HYDRAULIC DIAGRAM LIST	6-2
6-2	HYDRAULIC DIAGRAM - AXLE EXTENSION & STEER (WITHOUT TOW PACKAGE & WITH DUAL FRAME JACKS)	6-4
6-3	HYDRAULIC DIAGRAM - BRAKE WITH PRESSURE REDUCING VALVE (USED WITH AUSCO DRIVE BRAKES)	6-6
6-4	HYDRAULIC DIAGRAM - DRIVE	6-8
6-5	HYDRAULIC DIAGRAM - EXTEND-A-REACH (100HX+10 AND 110HXER)	6-12
6-6	HYDRAULIC DIAGRAM - LEVEL	6-14
6-7	HYDRAULIC DIAGRAM - LIFT	6-16
6-8	HYDRAULIC DIAGRAM - PUMP	6-18
6-9	HYDRAULIC DIAGRAM - ROTATE	6-22
6-10	HYDRAULIC DIAGRAM - SEQUENCE LINE	6-24
6-11	HYDRAULIC DIAGRAM - SWING	6-26

TABLE OF CONTENTS

FIGURE NO.	TITLE	PAGE NO.
6-12	HYDRAULIC DIAGRAM - TELESCOPE	6-28
SECTION 7 - ELECTRICAL		7-1
7-1	ELECTRICAL DIAGRAM LIST	7-2
7-2	WIRING SCHEMATIC - PLATFORM.....	7-8
7-3	WIRING SCHEMATIC - STANDARD.....	7-10
SECTION 8 - DECALS		8-1
8-1	DECALS INSTALLATION - BROWN DECALS	8-2
8-2	DECALS INSTALLATION - BLACK DECALS	8-8
SECTION 9 - RECOMMENDED SERVICE PARTS STOCK.....		9-1
SECTION 10 - SPECIAL OPTIONS		10-1

TABLE OF CONTENTS

FIGURE NO.

TITLE

PAGE NO.

SECTION 1 FRAME

TABLE OF CONTENTS

FIGURE	DESCRIPTION
1-1	STEERING AND AXLE/WHEEL INSTALLATIONS 1-2
1-2	DRIVE HUB ASSEMBLY 1-6
1-3	BRAKE ASSEMBLY - AUSCO 1-10
1-4	BRAKE ASSEMBLY - MICO 1-12
1-5	DRIVE MOTOR ASSEMBLY - VICKERS 1-16
1-6	DRIVE MOTOR ASSEMBLY - SAUER-DANFOSS 1-20
1-7	VALVES AND SWITCHES INSTALLATIONS (FRAME MOUNTED) 1-21
1-8	TOW PACKAGE INSTALLATION 1-28

SECTION 1 FRAME

FIGURE 1-1. STEERING AND AXLE/WHEEL DRIVE INSTALLATIONS

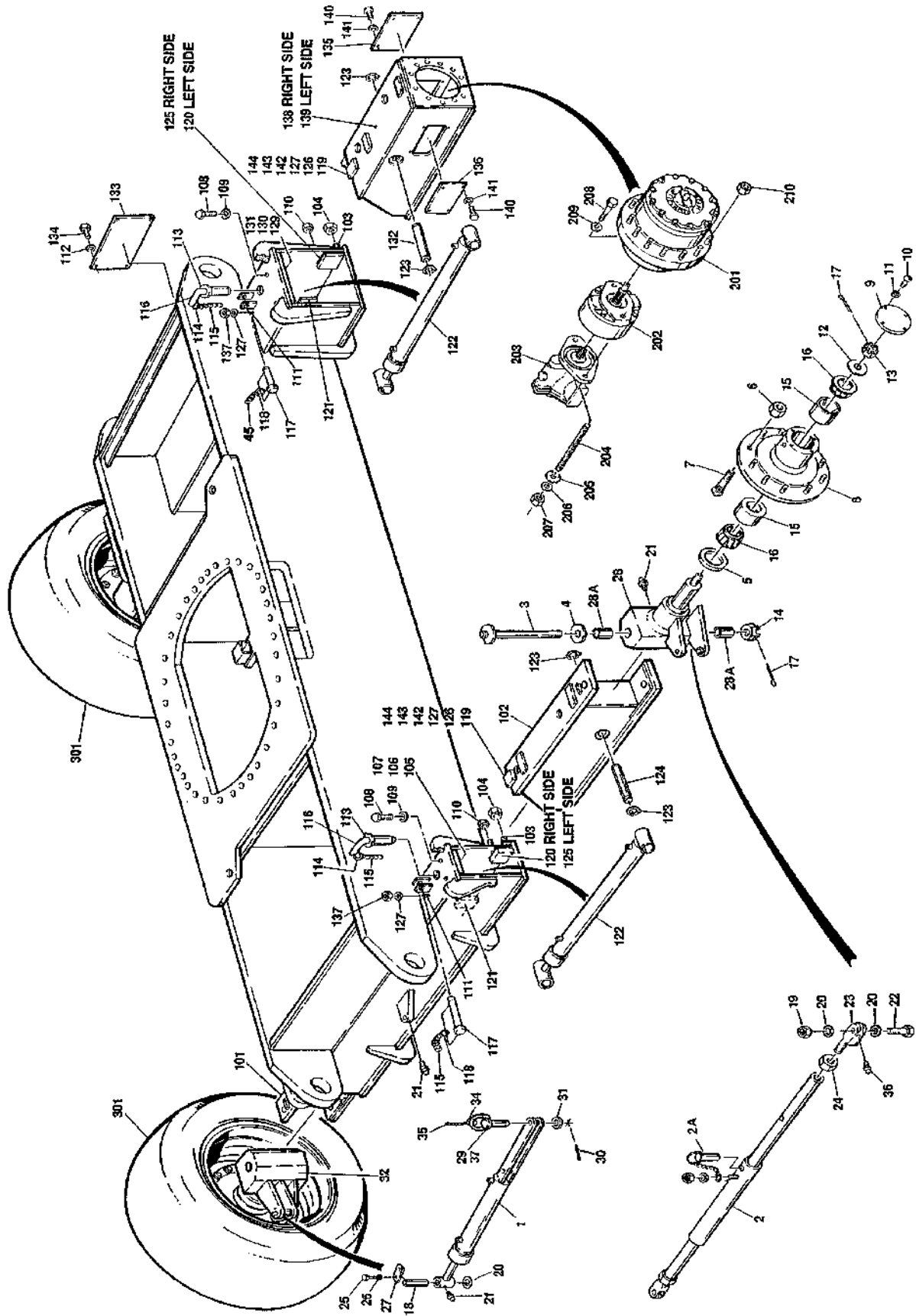

SECTION 1 FRAME

FIGURE 1-1. STEERING AND AXLE/WHEEL DRIVE INSTALLATIONS

FIG & ITEM #	PART NUMBER	DESCRIPTION	QTY.	REV.
	2360280	FRAME WELDMENT	Ref.	
	1281982	STEERING INSTALLATION	Ref.	F
	0239122	Standard	Ref.	5
	0259555	Standard (Machines with Tow Bar Package) (S/N 47309 to Present)	Ref.	1
1	1681934	Steer Cylinder Assembly (See Section 5 for Break-down)	1	
2	4843050	Tie-Rod Assembly	1	
2A	3420620	Pin, Quick Release	1	
3	3421553	Kingpin	2	
4	4740314	Washer, Thrust	2	
5	3960243	Seal, Hub	2	
6	3300007	Nut, Wheel	24	
7	0630078	Stud, Wheel	24	
8	2780159	Hub Assembly (Includes Item 7)	2	
9	1120347	Cap, Hub	2	
10	0721003	Bolt #10-24NC x 3/8"	8	
11	4761000	Lockwasher #10	8	
12	4740347	Washer, Hardened	2	
13	3323803	Nut, Slotted 1 3/4"-12NF	2	
14	3324203	Nut, Slotted 2"-12NF	2	
15	0440190	Cup, Bearing	4	
16	0440191	Cone, Bearing	4	
17	3451012	Pin, Cotter 5/16" x 3"	4	
18	3421524	Pin, Steer Cylinder	1	
19	3312602	Nut, Jam 1"- 8NC	2	
20	4740111	Washer, Thrust	5	
21	2160002	Fitting, Grease	3	
22	0642644	Bolt 1"-8NCx 5 1/2"	2	
23	0560605	Block	2	
24	3323002	Nut, Jam 1 1/4" - 12 NF	2	
25	0641507	Bolt 5/16"-18NC x 7/8"	2	
26	4761500	Lockwasher 5/16"	2	
27	3532561	Plate, Retainer	1	
28		Spindle (Left Side) Options:	1	
	4130206	Standard		
	4130370	Standard (Machines With Tow Bar Package)		
28A	0960821	Bushing, Bronze	2	
29	3421330	Pin, Clevis (Prior to S/N 33256)	1	
	3422635	Pin, Clevis (S/N 33256 to Present)	1	
	See Note	3421330 Pin (Prior to S/N 33256) (Note Recommend using 3422635 in place of original 3421330)		
30	3420158	Hairpin	1	
31	4712600	Flatwasher 1"	1	
32	4130205	Spindle (Right Side)	1	
	0960821	Bushing, Bronze	2	
33	0100011	Loctite #242 (Not Shown)	A/R	

SECTION 1 FRAME

FIGURE 1-1. STEERING AND AXLE/WHEEL DRIVE INSTALLATIONS (CONTINUED)

FIG & ITEM #	PART NUMBER	DESCRIPTION	QTY.	REV.
34	3760170	Ring, Quick Release	2	
35	1260017	Chain	8in/20cm	
36	2160001	Fitting, Grease - 90°	2	
37	2160003	Fitting, Grease - 45°	1	
	0239089	AXLES INSTALLATION	Ref.	9
101	4843031	Inner Axle Weldment (Front Right Side)	1	
102	4843030	Inner Axle Weldment (Front Left Side)	1	
103	3972218	Setscrew 3/4"-10NC x 2 1/4"	16	
104	3312202	Nut, Jam 3/4"-10NC	16	
105	0361632	Bar	2	
106	4070576	Shim 1/32"	2	
107	4070577	Shim 1/16"	2	
108	0642008	Bolt 5/8"-11NC x 1"	8	
109	4712000	Flatwasher 5/8"	8	
110	3311505	Locknut 5/16"-18NC	12	
111	4300032	Stud (Welded on Part)	4	
112	4761400	Lockwasher 1/4"	8	
113	4843032	Bushing Weldment	4	
114	3760106	D-Ring	4	
115	1260017	Chain #3	64in/1.6m	
116	3421546	Pin, Axle Lock	4	
117	3421565	Snap-Pin	4	
118	3760170	Ring, Quick Release	4	
119	3340527	Wear Pad	4	
120	0560674	Block, Axle Shim	8	
121	0560673	Block, Axle Shim	2	
122	1681964	Axle Extension Cylinder Assembly Options (See Section 5 for Breakdown)	2	
123	3760140	Ring, Retaining	8	
124	3421549	Pin, Attaching (Front Axle Cylinder)	2	
125	0560675	Block, Axle Shim	2	
126	0641406	Bolt 1/4"-20NC x 3/4"	8	
127	4751400	Flatwasher 1/4"	12	
128	0100011	Loctite #242 (Not Shown)	A/R	
129	0361631	Bar, Wear	2	
130	4070574	Shim 1/16"	2	
131	4070575	Shim 1/32"	2	
132	3421548	Pin, Attaching (Rear Axle Cylinder)	2	
133	3532592	Plate, Cover	1	
134	0641403	Bolt 1/4"-20NC x 5/8"	4	
135	3532590	Plate, Cover	2	
136	3532591	Plate, Cover	2	
137	3300151	Nut, Acorn	4	
138	4843028	Inner Axle Weldment (Rear Right Side)	1	
139	4843023	Inner Axle Weldment (Rear Left Side)	1	
140	0641505	Bolt 5/16"-18NC x 5/8"	16	
141	4761500	Lockwasher 5/16"	16	
142	4070670	Shim 1/8"	A/R	

SECTION 1 FRAME

FIGURE 1-1. STEERING AND AXLE/WHEEL DRIVE INSTALLATIONS (CONTINUED)

FIG & ITEM #	PART NUMBER	DESCRIPTION	QTY.	REV.
143	4070672	Shim 1/32"	A/R	
144	4070674	Shim 1/16"	A/R	
	0239152	WHEEL DRIVE INSTALLATION	Ref.	3/B
201	2780155	Hub Assembly (See Figure 1-2 for Breakdown)	2	
202		Brake Assembly Options:	2	
	0920072	Prior to March 1992 (See Figure 1-3 for Breakdown)		
	0920084	March 1992 to S/N 33476 (See Figure 1-4 for Breakdown)		
	0920110	S/N 33476 to Present (See Figure 1-4 for Breakdown)		
	0920119	Optional Replacement (Note: Can be used as suitable replacement. Requires P/N 4300097 5-1/8" long Stud) (was p/n 0920117)		
		Note: Repair Kit p/n 7018612 & Mounting Face Gasket p/n 7000731 are only Service Parts available for Brake p/ns 0920119 & 0920117.		
203		Motor Assembly Options:	2	
	Use 1001096405	Original Equipment (was p/n 3160132 - See Figure 1-5 for Breakdown)		
	1001096405	Service Replacement Kit (See Figure 1-6 for Breakdown)		
204	4300092	Stud 1/2"-13NC x 5 1/2"	4	
205	4751800	Flatwasher 1/2"	4	
206	4761800	Lockwasher 1/2"	4	
207	3311801	Nut 1/2"-13NC	4	
208	0642216	Bolt 3/4"-10NC x 2"	24	
209	4762200	Lockwasher 3/4" Narrow	24	
210	3300007	Lugnut 3/4"-16NF	24	
		TIRE AND WHEEL INSTALLATIONS	Ref.	
		Note: Assemblies may require ballast/foam filling to manufacturer's specifications prior to installing on a machine. Refer to Operation & Safety or Service & Maintenance Manuals. Purchase individual tire and/or rim only if able to foam fill tire & wheel assembly, otherwise, purchase complete assembly.		
301	0239344	Tire and Wheel Assembly - 15 x 22.5 Foam-Filled (Prior to April 1993)	A/R	
	0253929	Tire and Wheel Assembly - 385/65R22.5 Foam-Filled (April 1993 to S/N 44997)	A/R	
	0259456	Tire and Wheel Assembly - 385/65R22.5 Foam-Filled L.H. (S/N 44997 to Present)	2	
	0259442	Tire and Wheel Assembly - 385/65R22.5 Foam-Filled R.H. (S/N 44997 to Present)	2	

SECTION 1 FRAME

FIGURE 1-2. DRIVE HUB ASSEMBLY

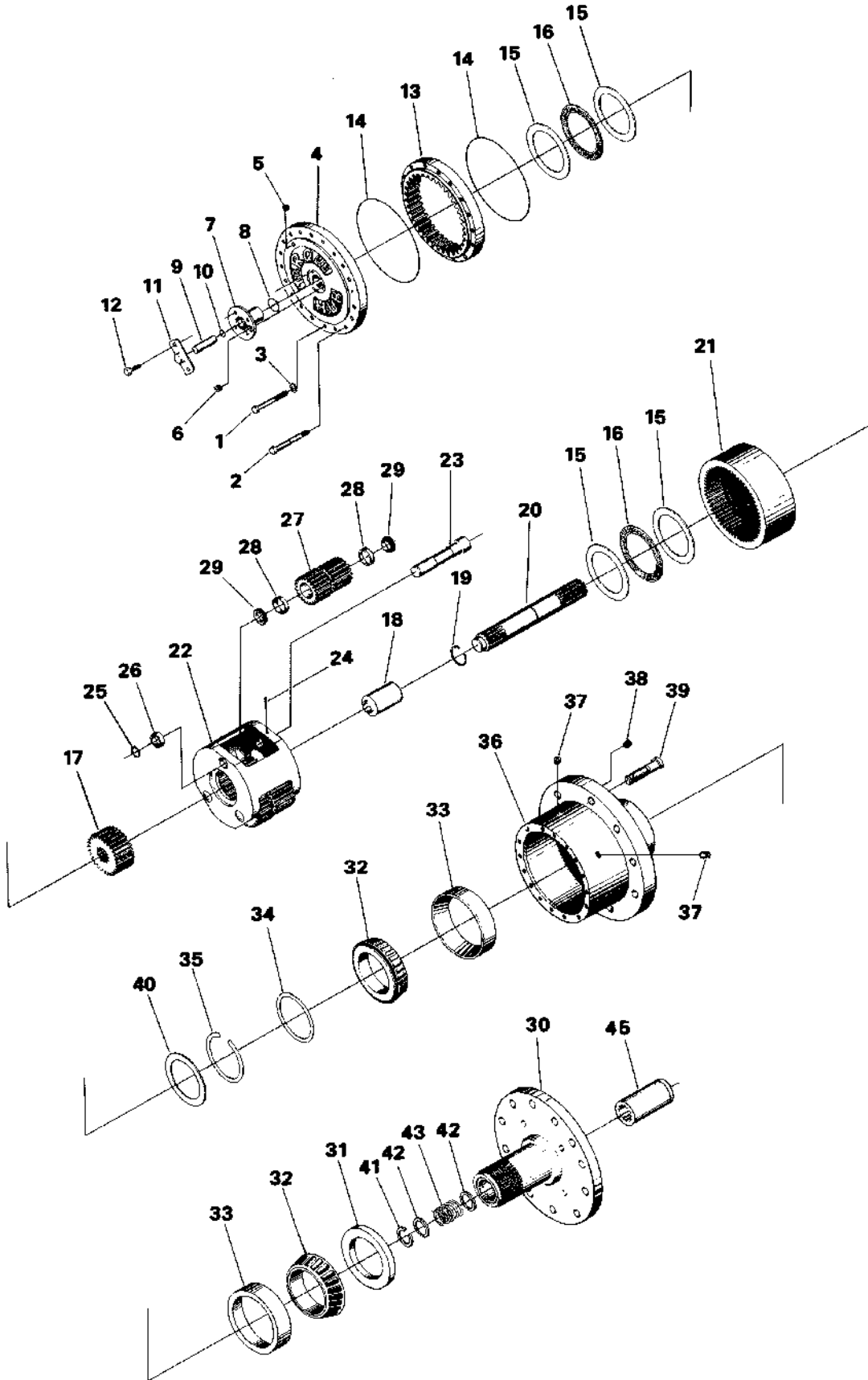

SECTION 1 FRAME

FIGURE 1-2. DRIVE HUB ASSEMBLY

FIG & ITEM #	PART NUMBER	DESCRIPTION	QTY.	REV.
	2780155	DRIVE HUB ASSEMBLY	Ref.	
1	7001974	Bolt, Hex Head	16	
2	7001975	Bolt, Hex Head Shoulder	4	
3	7001976	Lockwasher	20	

	7001965	Cover Assembly	1	
4	7001966	Cover	1	
5	7001928	Plug, Pipe	1	
6	7000243	Plug, Pipe	1	
7	7001967	Cap, Cover	1	
8	Kit	O-Ring	1	
9	7001968	Rod, Disconnect	1	
10	Kit	O-Ring	1	
11	7000231	Cap, Disconnect	1	
12	7000220	Bolt	4	
13	7001963	Gear, Ring	1	
14	Kit	O-Ring	2	
15	7001972	Thrustwasher	4	
16	7001973	Bearing, Thrust	2	
17	7001971	Gear, Input (Sun Gear)	1	
18	7001970	Spacer, Thrust	1	
19	7000285	Ring, Retaining	1	
20	7001919	Shaft, Input	1	
21	7007657	Gear, Internal	1	

	7001910	Carrier Assembly	1	
22	7001955	Carrier	1	
23	7001959	Shaft, Planet	3	
24	7001956	Pin, Roll	3	
25	7001962	Ring, Retaining	3	
26	7001961	Spacer	3	
27	7017003	Gear, Cluster	3	
28	7001957	Cup, Bearing	6	
29	7001958	Cone, Bearing	6	
	7007698	Hub and Spindle Assembly	1	
30	7007699	Spindle	1	
31	Kit	Seal	1	
32	7001948	Cup, Bearing	2	
33	7001947	Cone, Bearing	2	
34	7001949	Shim, Bearing	1	
35	7001950	Ring, Retaining	1	
36	7001951	Hub	1	
37	7001928	Plug, Pipe	2	
38	7001952	Plug, Magnetic	1	
39	7000265	Stud	12	
40	7001977	Ring, Keeper	1	
41	7000284	Ring, Retaining	1	
42	7000282	Washer	2	

SECTION 1 FRAME

**S
E
C
T
I
O
N

1

F
R
A
M
E**

FIGURE 1-2. DRIVE HUB ASSEMBLY (CONTINUED)

FIG & ITEM #	PART NUMBER	DESCRIPTION	QTY.	REV.
43	7000283	Spring	1	
44	Not Used			
45	7000290	Coupling, Input	1	
	2900560	Seal Kit (Includes Items 8, 10, 14 and 31)		

SECTION 1 FRAME

FIGURE 1-2. DRIVE HUB ASSEMBLY (CONTINUED)

FIG & ITEM #	PART NUMBER	DESCRIPTION	QTY.	REV.

SECTION 1 FRAME

FIGURE 1-3. DRIVE BRAKE ASSEMBLY - AUSCO

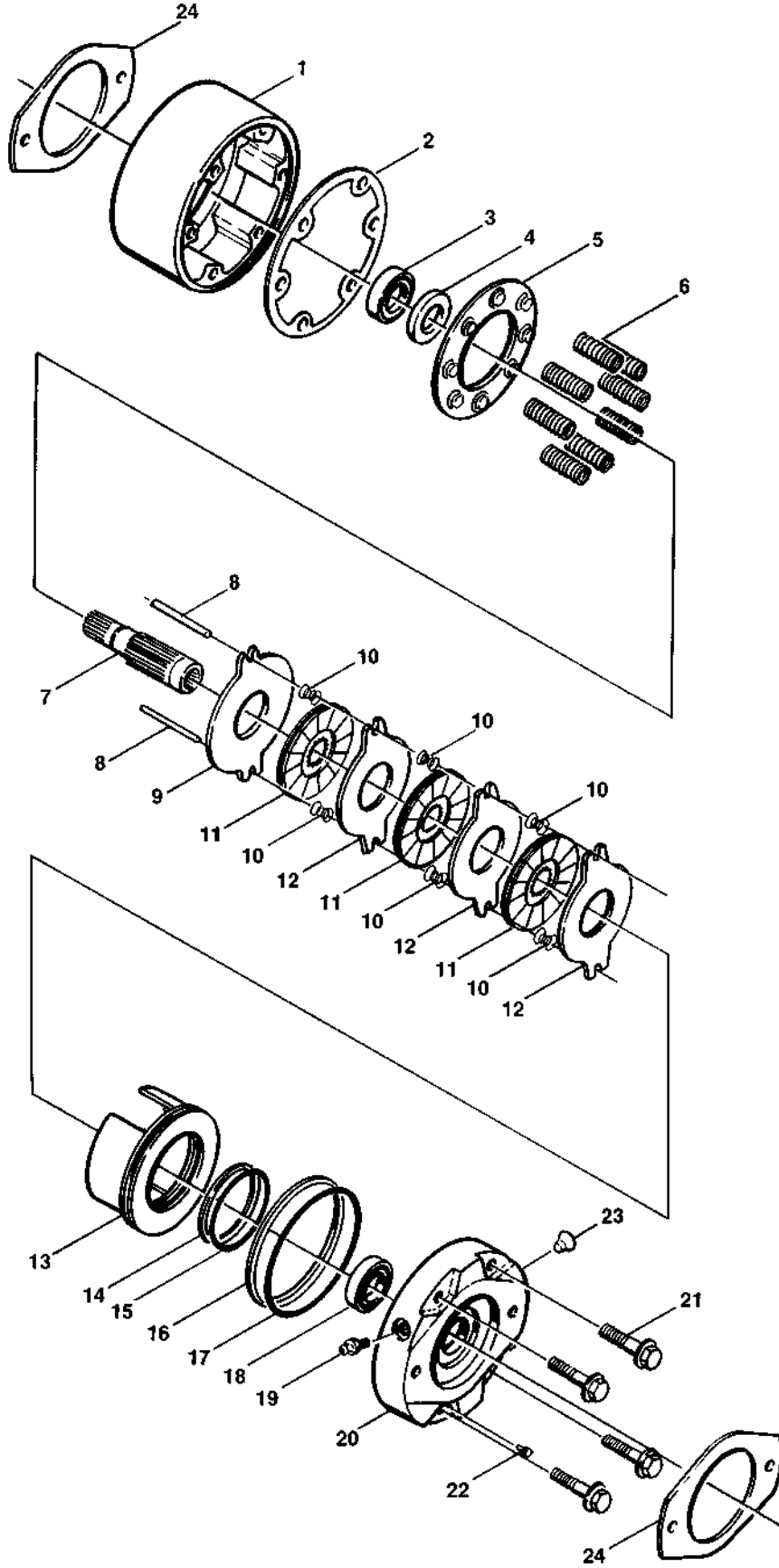

SECTION 1 FRAME

FIGURE 1-3. DRIVE BRAKE ASSEMBLY - AUSCO

FIG & ITEM #	PART NUMBER	DESCRIPTION	QTY.	REV.
	0920072	DRIVE BRAKE ASSEMBLY - AUSCO	Ref.	D
1	7003047	Housing	1	
2	Kit	Gasket	1	
3	7003049	Bearing	1	
4	Kit	Seal, Oil	1	
5	7003051	Retainer, Spring	1	
6	7003052	Spring, Compression	8	
7	7003070	Shaft, Splined	1	
8	7000717	Pin, Torque	2	
9	7003054	Disc, Primary	1	
10	7003006	Spring, Separator	6	
11	7003055	Disc, Rotating	3	
12	7003056	Disc, Stationary	3	
13	7003057	Piston	1	
14	Kit	Ring, Backup	1	
15	Kit	O-Ring	1	
16	Kit	Ring, Backup	1	
17	Kit	O-Ring	1	
18	7000760	Bearing	1	
19	7000796	Screw, Bleeder	1	
20	7003071	Plate, Power	1	
21	7003007	Screw	4	
22	7003059	Valve, Pressure	1	
23	7000728	Plug	1	
24	Kit	Gasket	2	
	2900662	Seal Kit (Includes Items 2,4,14,15,16, 17 and 24)	1	
	7003069	Gasket Kit (Includes Item 24)	1	

SECTION 1 FRAME

FIGURE 1-4. DRIVE BRAKE ASSEMBLY - MICO

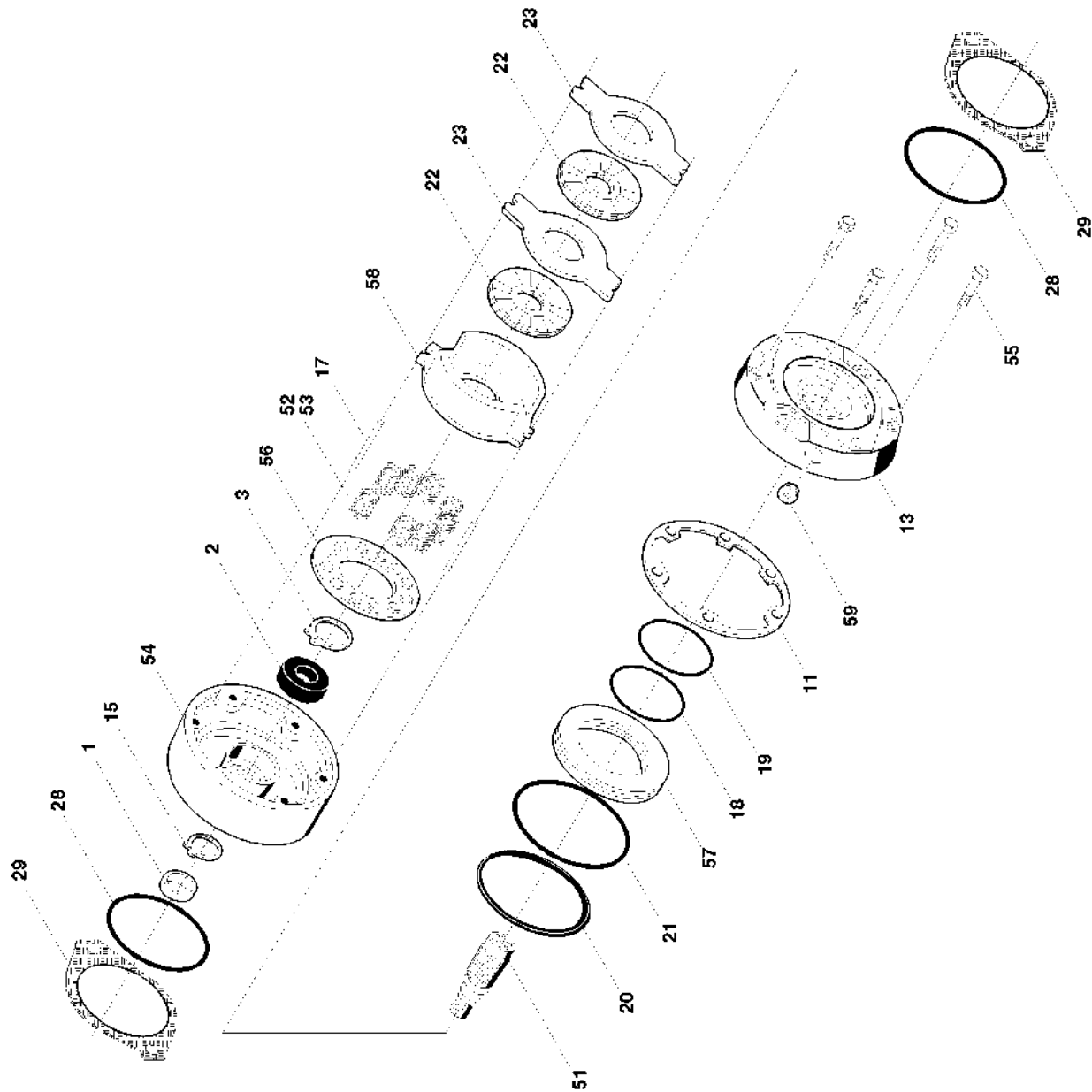

SECTION 1 FRAME

FIGURE 1-4. DRIVE BRAKE ASSEMBLY - MICO

FIG & ITEM #	PART NUMBER	DESCRIPTION	QTY.	REV.
1	Kit	Seal, Oil	1	
2	Kit	Bearing	1	
3	7007977	Ring, Retaining	1	
4	Not Used			
5	Not Used			
6	Not Used			
7	Not Used			
8	Not Used			
9	Not Used			
10	Not Used			
11	Kit	Seal, Case	1	
12	Not Used			
13	7007986	Cover	1	
14	Not Used			
15	7011716	Ring, Retainer	1	
16	Not Used			
17	7007987	Pin, Dowel	2	
18	Kit	Ring, Back-up	1	
19	Kit	O-Ring	1	
20	Kit	Ring, Back-up	1	
21	Kit	O-Ring	1	
22	Kit	Rotor	2	
23	Kit	Stator	2	
24	Not Used			
25	7007924	Plug, Pipe	1	
26 and 27	Not Used			
28	Kit	O-Ring	2	
29	7007933	Gasket	2	

	2900766	Seal Kit (Includes Items 1,11,18,19,20,21,28 and 29)	1	
	2900768	Bearing Kit (Includes Items 1,2,11,28 and 29)	1	
		DRIVE BRAKE ASSY - MICO (VARIABLE PARTS)		
	0920084	Prior To S/N 33476	Ref.	A
	0920110	S/N 33476 To Present	Ref.	B
51	7011712	Shaft	1	
52		Spring Options:	A/R	
	7007979	Inner Spring - Prior To S/N 33476	6	
	7007980	Outer Spring - Prior To S/N 33476	6	
	Not Required	S/N 33476 To Present	0	
53		Spring Options:	A/R	
	Not Required	Prior To S/N 33476	0	
	7007970	Spring (Red) - S/N 33476 To Present	6	
	7018602	Spring (Blue) - S/N 33476 To Present	3	
54		Housing Options:	1	
	7011713	Prior To S/N 33476		
	7018605	S/N 33476 To Present		

SECTION 1 FRAME

SECTION 1 FRAME

FIGURE 1-4. DRIVE BRAKE ASSEMBLY - MICO (CONTINUED)

FIG & ITEM #	PART NUMBER	DESCRIPTION	QTY.	REV.
55	7007985	Bolt, Washer Head Options: Prior To S/N 33476	4	
	7018607	S/N 33476 To Present		
56	7011717	Guide, Spring Options: Prior To S/N 33476	1	
	7018606	S/N 33476 To Present		
57	7007923	Piston Options: Prior To S/N 33476	1	
	7018603	S/N 33476 To Present		
58	7007923	Plate, Return/Separator Assembly Options: Prior To S/N 33476 Components:	1	
	Kit	Plate, Return	1	
	7011715	Separator Assembly	2	
	7011714	Pin	4	
	7007983	Separator	2	
	7018603	S/N 33476 To Present Components:		
	Kit	Plate, Return	1	
59		Plug Options:	1	
	7007914	Bleeder Screw - Prior To S/N 33476		
	7018609	Plug - S/N 33476 To Present		
	2900767	Lining Kit Options (Includes Items 58, 11, 22, 23, 28 and 29): Prior To S/N 33476	1	
	7018608	S/N 33476 To Present		

SECTION 1 FRAME

FIGURE 1-4. DRIVE BRAKE ASSEMBLY - MICO (CONTINUED)

FIG & ITEM #	PART NUMBER	DESCRIPTION	QTY.	REV.

SECTION 1 FRAME

FIGURE 1-5. DRIVE MOTOR ASSEMBLY - VICKERS

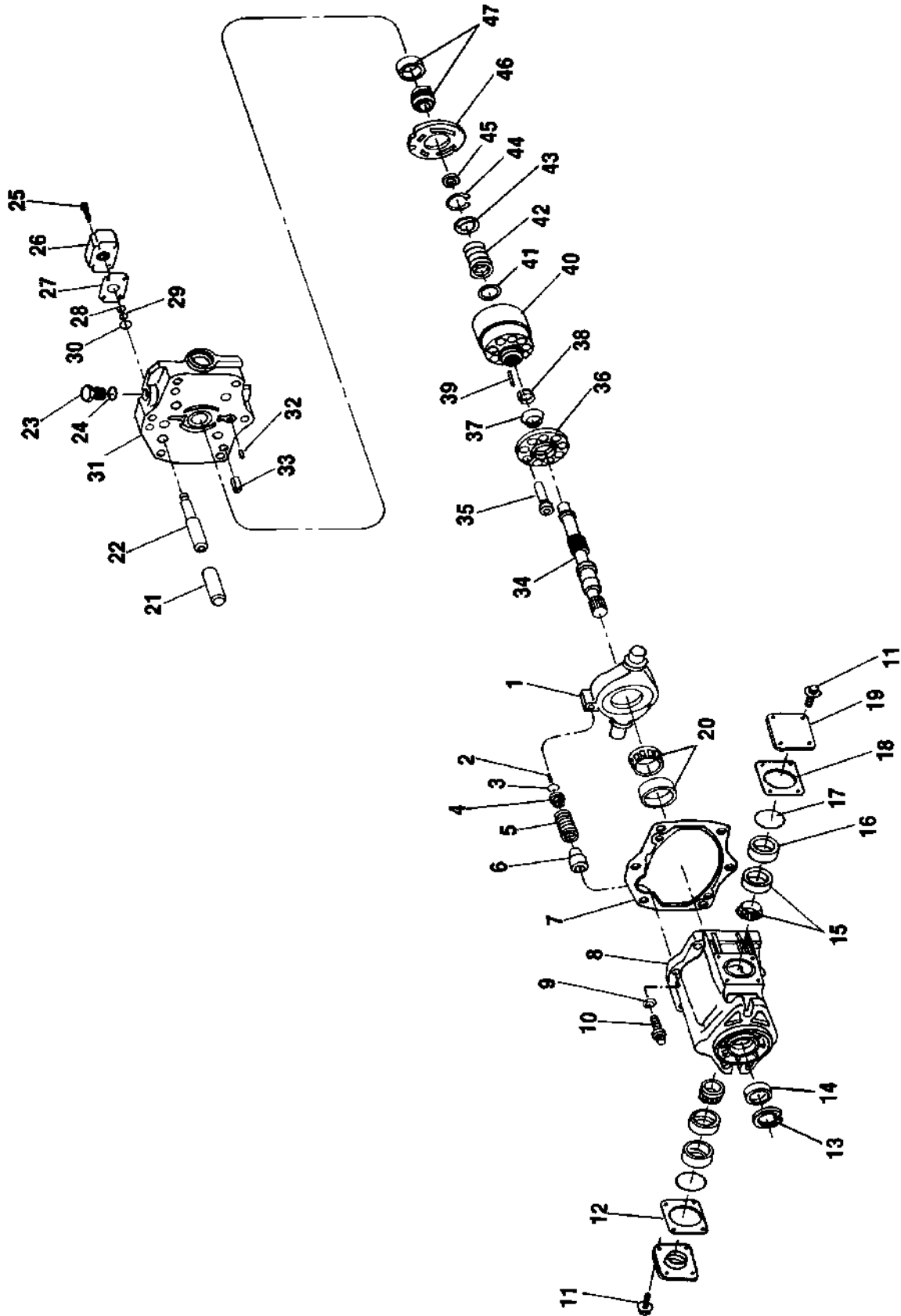

SECTION 1 FRAME

FIGURE 1-5. DRIVE MOTOR ASSEMBLY - VICKERS

FIG & ITEM #	PART NUMBER	DESCRIPTION	QTY.	REV.
	3160132	DRIVE MOTOR ASSEMBLY - VICKERS	Ref.	B
1	7006766	Yoke	1	
2	7006767	Roll Pin	1	
3	7006768	Spherical Seat	1	
4	7006769	Spring Seat	1	
5	7006774	Yoke Spring	1	
6	7006776	Yoke Stop	1	
7	Kit	Gasket	1	
8	7006786	Housing	1	
9	7006787	Washer	6	
10	7006788	Screw	6	
11	7006789	Screw	4	
12		Shim (Included with Item 18)	1	
13	7006721	Retaining Ring	1	
14	7006796	Shaft	1	
15	7006791	Bearing	2	
16	7006792	Pintle Bearing	2	
17	Kit	O-Ring	2	
18	7006794	Shim Kit (Includes Item 12)	1	
19	7006795	Cover	2	
20	7006719	Bearing	1	
21	7006797	Piston	1	
22	7006798	Piston Rod	1	
23	7006703	Plug	1	
24	Kit	O-Ring	1	
25	7009300	Screw	4	
26	7009301	Control Block	1	
27	Kit	Gasket	1	
28	Kit	O-Ring	1	
29	Kit	Back-up Ring	1	
30	7009305	Retaining Ring	1	
31	7009306	Valve Block	1	
32	7006706	Pin	1	
33	7009307	Pin	2	
34	7009308	Shaft	1	
35	7006717	Piston and Shoes	9	
36	7006716	Shoe Plate	1	
37	7006715	Spherical Washer	1	
38	7006714	Pin, Retainer	1	
39	7006713	Pin	3	
40	7006712	Cylinder, Block	1	
41	7006711	Spring Washer	1	
42	7006710	Spring	1	
43	7006709	Spring Washer	1	
44	7009309	Retaining Ring	1	
45	7006707	Bearing Spacer Kit	1	
46	7009310	Wafer Plate	1	
47	7006704	Bearing S/A	1	

SECTION 1 FRAME

**S
E
C
T
I
O
N

1

F
R
A
M
E**

FIGURE 1-5. DRIVE MOTOR ASSEMBLY - VICKERS (CONTINUED)

FIG & ITEM #	PART NUMBER	DESCRIPTION	QTY.	REV.
	2900659	----- Seal Kit (Includes 7,14,17,24,27,28 and 29)	1	

SECTION 1 FRAME

FIGURE 1-5. DRIVE MOTOR ASSEMBLY - VICKERS (CONTINUED)

FIG & ITEM #	PART NUMBER	DESCRIPTION	QTY.	REV.

**S
E
C
T
I
O
N

1

F
R
A
M
E**

SECTION 1 FRAME

FIGURE 1-6. DRIVE MOTOR ASSEMBLY - SAUER-DANFOSS

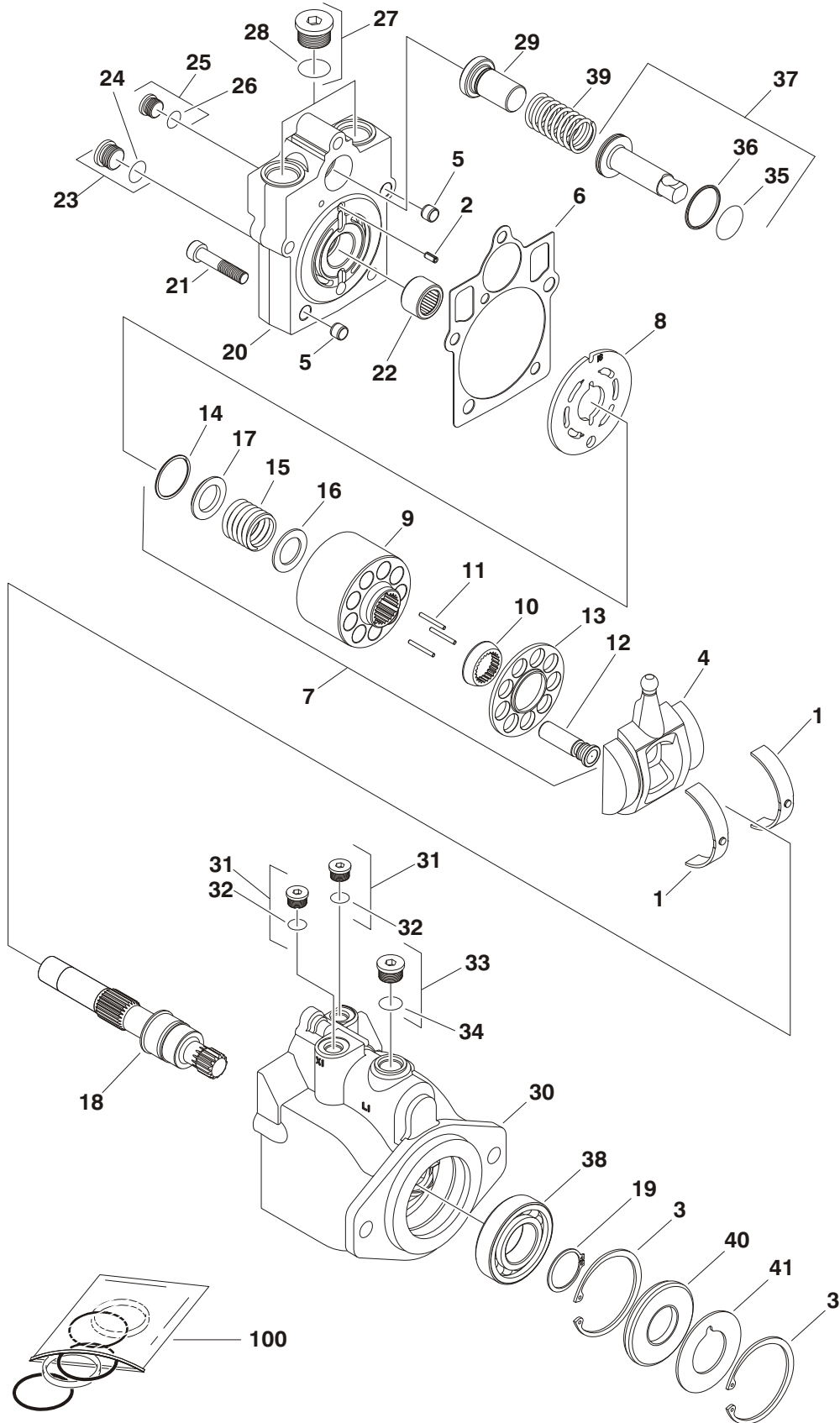

SECTION 1 FRAME

FIGURE 1-6. DRIVE MOTOR ASSEMBLY - SAUER-DANFOSS

FIG & ITEM #	PART NUMBER	DESCRIPTION	QTY.	REV.
	1001096405	DRIVE MOTOR ASSEMBLY KIT - SAUER-DANFOSS	Ref.	2
	1001096406	Drive Motor Assembly - Sauer-Danfoss	Ref.	A
1	7022302	Bearing, Journal	2	
2	7007446	Pin	1	
3	7007438	Ring, Retaining	2	
4	70000794	Swashplate	1	
5	Not Available	Pin	2	
6	Use Item 100	Gasket	1	
7	7027740	Cylinder Block Kit (Includes Items 9-17)	1	
8	7024862	Plate, Valve	1	
9	Use Item 7	Block, Cylinder	1	
10	70000856	Guide, Slipper Retainer	1	
11	7021275	Pin, Slipper Hold Down	3	
12	7024865	Piston Assembly	9	
13	70000857	Retainer, Slipper	1	
14	7022311	Ring, Retaining	1	
15	7024867	Spring	1	
16	7024868	Washer	1	
17	7022314	Retainer, Spring	1	
18	7023910	Shaft	1	
19	7007439	Ring, Retaining	1	
20	70000795	Cap, End - Axial	1	
21	7022368	Screw	5	
22	7021249	Bearing, Needle	1	
23	7022321	Plug (Includes Item 24)	1	
24	7022322	O-Ring	1	
25	7007420	Plug (Includes Item 26)	1	
26	7021256	O-Ring	1	
27	7007419	Plug (Includes Item 28)	2	
28	7007418	O-Ring	2	
29	Not Available	Seat, Spring	1	
30	Not Available	Housing	1	
31	7007420	Plug (Items Item 32)	2	
32	7021256	O-Ring	2	
33	7022321	Plug (Items Item 34)	1	
34	7022322	O-Ring	1	
35	7022324	O-Ring	1	
36	7022325	Ring, Seal	1	
37	7024871	Piston, Servo	1	
38	7007437	Bearing	1	
39	7022326	Spring	1	
40	7007459	Seal, Lip	1	
41	7022371	Washer, Support	1	
100	7022328	Seal Kit (Includes Items 6,24,26,28,32,34,35,36 and 40)	1	
		Adapter Options:	Ref.	
201	70001098	Adapter 12x16 (Not Shown)	1	
202	70001099	Adapter 8x10 (Not Shown)	1	

SECTION 1 FRAME

FIGURE 1-7. VALVES AND SWITCHES INSTALLATIONS (FRAME MOUNTED)

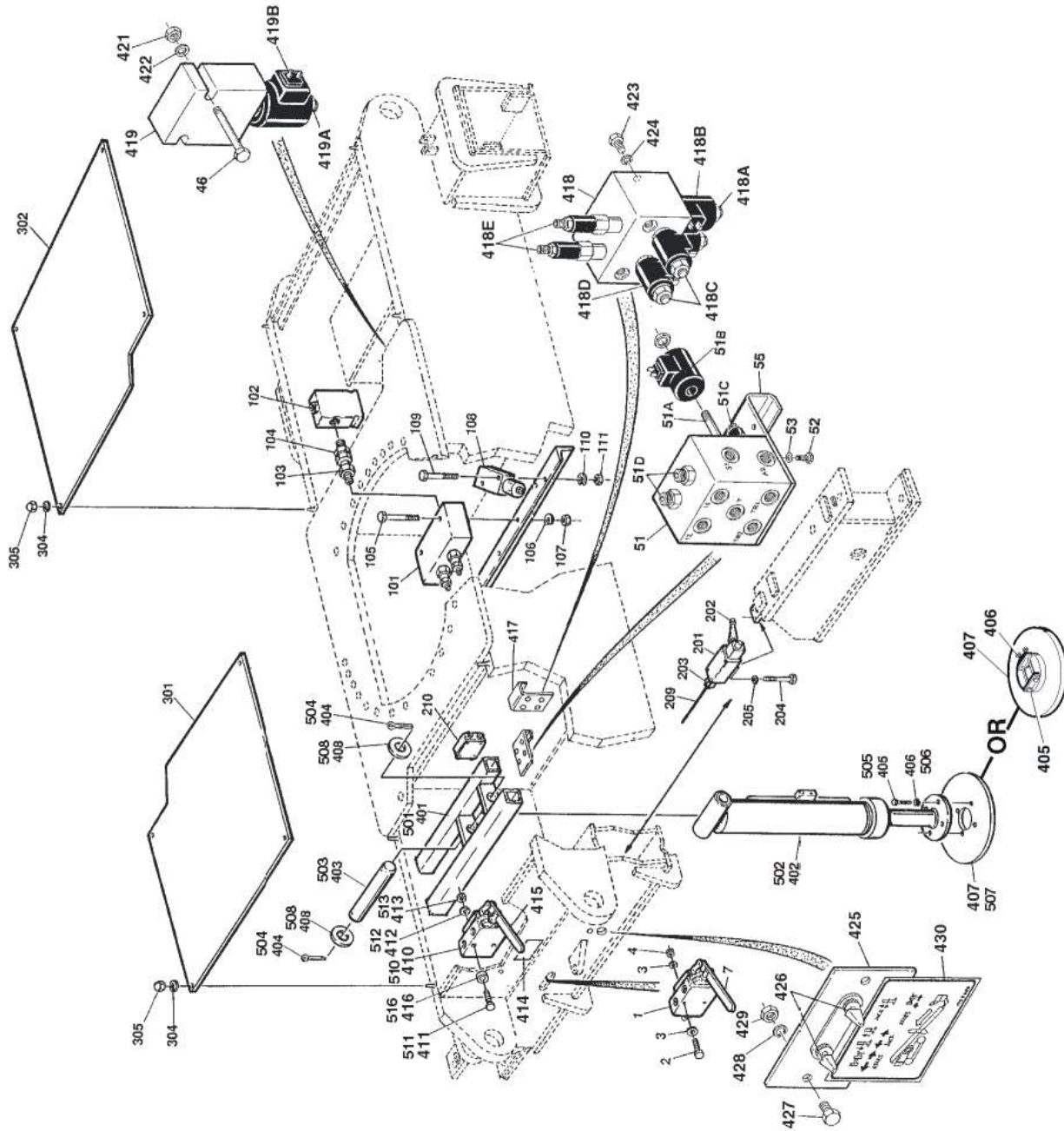

SECTION 1 FRAME

FIGURE 1-7. VALVES AND SWITCHES INSTALLATIONS (FRAME MOUNTED)

FIG & ITEM #	PART NUMBER	DESCRIPTION	QTY.	REV.
	0239072	SELECTOR VALVE INSTALLATION (USED WITHOUT AXLE JACK OR WITH SINGLE AXLE JACK)	Ref.	B
1	4640039	Valve, Selector	1	
	7006851	O-Ring (Valve Seals)	2	
2	0641626	Bolt 3/8"-16NC x 3 1/4"	2	
3	4751600	Flatwasher 3/8"	2	
	4761600	Lockwasher 3/8"	2	
4	3311601	Nut 3/8"-16NC	2	
5 to 6	Not Used			
7	2980089	Lever	1	
8	4751400	Flatwasher 1/4"	6	
	0256611	SELECTOR VALVE INSTALLATION (USED WITH DUAL JACKS)	Ref.	2
51	4640986	Valve, Selector	1	
51A	7012995	Cartridge Less Coil	2	
	7012518	Seal Kit - 7012995 Cartridge (1 Per Cartridge)	2	
51B	7000645	Coil	2	
51C	7017409	Cartridge, Directional	2	
	7012518	Seal Kit - 7017409 Cartridge (1 Per Cartridge)	2	
51D	7011336	Cartridge (Sun)	2	
	2900770	Seal Kit - 7011336 Cartridge (1 Per Cartridge)	2	
52	0641506	Bolt 5/16"-18NC x 3/4"	2	
53	4751500	Flatwasher 5/16"	2	
54	0100011	Loctite (Not Shown)	A/R	
55	3539843	Plate, Mounting	1	
	0239046	VALVES INSTALLATION	Ref.	5
101	4640451	Valve, Counterbalance	1	
	7010630	Cartridge	2	
	7011317	Seal Kit - 7010630 Cartridge	2	
102	4640260	Valve, Flow Divider	1	
	Not Available	Cartridge (Vickers/Modular Controls Version)	1	
	7009379	Seal Kit (Vickers/Modular Controls Version)	1	
	7007321	Cartridge (Fluid Controls Version)	1	
	7007323	Seal Kit (Fluid Controls Version)	1	
103	2220061	Fitting, Adapter	1	
104	2180134	Fitting, Straight	1	
105	0641626	Bolt 3/8"-16NC x 3 1/4"	2	
106	4761600	Lockwasher 3/8"	2	
107	3311601	Nut 3/8"-16NC	2	
108	4640123	Valve, 2 Speed	1	
	7012518	Seal Kit (Hydraforce Version)	1	
	7000558	Seal Kit (FPS Version)	1	
	7004368	Coil (Hydraforce Version)	1	
	7006075	Coil (FPS Version)	1	

SECTION 1 FRAME

FIGURE 1-7. VALVES AND SWITCHES INSTALLATIONS (FRAME MOUNTED) (CONTINUED)

FIG & ITEM #	PART NUMBER	DESCRIPTION	QTY.	REV.
109	0641518	Bolt 5/16"-18NC x 2 1/4"	2	
110	4761500	Lockwasher 5/16"	2	
111	3311501	Nut 5/16"-18NC	2	
	0250993	AXLE LIMIT SWITCHES INSTALLATION	Ref.	3
201	Not Used			
202	3534395	Plate, Switch Mounting	4	
203	4360277	Switch, Limit	4	
204	4360236	Head, Switch Actuator	4	
205	3900168	Bolt, Drilled Head #10-24NC x 1 3/4"	8	
206	4920140	Lockwire	4	
207	4360237	Arm and Roller	2	
208	4360278	Arm and Roller	2	
209	4460049	Connector, Strain Relief	4	
210	0860037	Box, Electrical	1	
	3500812	Cover, Electrical Box	1	
	4460023	Connector, Strain Relief	5	
	3311401	Nut 1/4"-20NC	2	
	4761400	Lockwasher 1/4"	2	
211 to 215	Not Used			
216	1100049	Cam	4	
217	4564974	Tube, Cable Carrier	2	
	0239126	FRAME SHIELDS INSTALLATION	Ref.	C
301	4060681	Shield (Front)	1	
302	4060682	Shield (Rear)	1	
303	Not Used			
304	4761400	Lockwasher 1/4"	8	
305	3300151	Nut, Acorn 1/4"-20NC	8	
306	0100011	Loctite #242 (Not Shown)	A/R	
	0256602	AXLE LIFT CYLINDER INSTALLATION (WITH DUAL AXLE JACK)	Ref.	6
401	4843122	Bracket Weldment	2	
402		Axle Lift Cylinder Assembly Options:	2	
	1681991	Prior to S/N 34133 (See Section 5 for Breakdown)		
	1683596	S/N 34133 to Present (See Section 5 for Breakdown)		
403	3421584	Pin	2	
404	3450508	Pin, Cotter	4	
405		Bolt Options:	4	
	0641809	Bolt 1/2"-13NC x 1 1/8" (Prior to S/N 34133)		
	0641844	Bolt 1/2"-13NC x 5 1/8" (S/N 34133 to Present)		
406		Hardware Options:	4	
	4761800	Lockwasher 1/2" (Prior to S/N 34133)		
	3311805	Locknut 1/2"-13NC (S/N 34133 to Present)		

SECTION 1 FRAME

FIGURE 1-7. VALVES AND SWITCHES INSTALLATIONS (FRAME MOUNTED) (CONTINUED)

FIG & ITEM #	PART NUMBER	DESCRIPTION	QTY.	REV.
407		Options:	2	
	3532839	Plate, Base (Prior to S/N 34133)		
	3340831	Weldment, Jack Pad (S/N 34133 to Present)		
408	Use 4713400	Washer, Spacer (Was P/N 4740243)	4	
409	0100011	Loctite #242 (Not Shown) (Prior to S/N 34133)	A/R	
410	3539843	Plate, Valve Mounting	1	
411 to 417	Not used			
418	4640987	Valve, Select	1	
418A	7012995	Cartridge Less Coil	2	
	7012518	Seal Kit (1 Per Assembly)	2	
418B	7000645	Coil (1 Per Assembly)	2	
418C	7017408	Cartridge Less Coil	2	
	7012967	Seal Kit (1 Per Assembly)	2	
418D	7012539	Coil (1 Per Assembly)	2	
418E	7012912	Cartridge, Relief	2	
	7012998	Seal Kit (1 Per Assembly)	2	
419	4640967	Valve, 3 Way	2	
419A	7012995	Cartridge Less Coil	2	
	7012518	Seal Kit (1 Per Assembly)	2	
419B	7000645	Coil (1 Per Assembly)	2	
420	0641414	Bolt 1/4"-20NC x 1 3/4"	4	
421	4711400	Flatwasher 1/4" Narrow	4	
422	3311405	Locknut 1/4"-20NC	4	
423	0641506	Bolt 5/16"-18NC x 3/4"	2	
424	4751500	Flatwasher 5/16"	2	
425	3539631	Plate, Switch Mounting	2	
426	4360314	Switch, Toggle	4	
427	0641409	Bolt 1/4"-20NC x 1 1/8"	4	
428	4761400	Lockwasher 1/4"	4	
429	3311401	Nut 1/4"-20NC	4	
430	1703083	Decal	2	
	0239291	AXLE LIFT CYLINDER INSTALLATION (WITH SINGLE AXLE JACK)	Ref.	9
501	4843122	Bracket Weldment	1	
502	1681991	Axle Lift Cylinder Assembly (See Section 5 for Breakdown)	1	
503	3421584	Pin	1	
504	3450508	Pin, Cotter	2	
505	0641809	Bolt 1/2"-13NC x 1 1/8"	4	
506	4761800	Lockwasher 1/2"	4	
507	3532839	Plate, Base	1	
508	4740243	Washer, Spacer	2	
509	0100011	Loctite #242 (Not Shown)	A/R	
510	4640039	Valve, Control	1	
	7006851	O-Ring (Valve Seals)	2	
511	0641632	Bolt 3/8"-16NC x 4"	2	
512	4761600	Lockwasher 3/8"	2	
513	3311601	Nut 3/8"-16NC	2	

SECTION 1 FRAME

FIGURE 1-7. VALVES AND SWITCHES INSTALLATIONS (FRAME MOUNTED) (CONTINUED)

FIG & ITEM #	PART NUMBER	DESCRIPTION	QTY.	REV.
514	3252453	Nameplate	1	
515	2980089	Lever	1	
	4751400	Flatwasher 1/4"	6	
516	4565166	Tube, Spacer	2	

SECTION 1 FRAME

FIGURE 1-7. VALVES AND SWITCHES INSTALLATIONS (FRAME MOUNTED) (CONTINUED)

FIG & ITEM #	PART NUMBER	DESCRIPTION	QTY.	REV.

**S
E
C
T
I
O
N

1

F
R
A
M
E**

SECTION 1 FRAME

FIGURE 1-8. TOW PACKAGE INSTALLATIONS

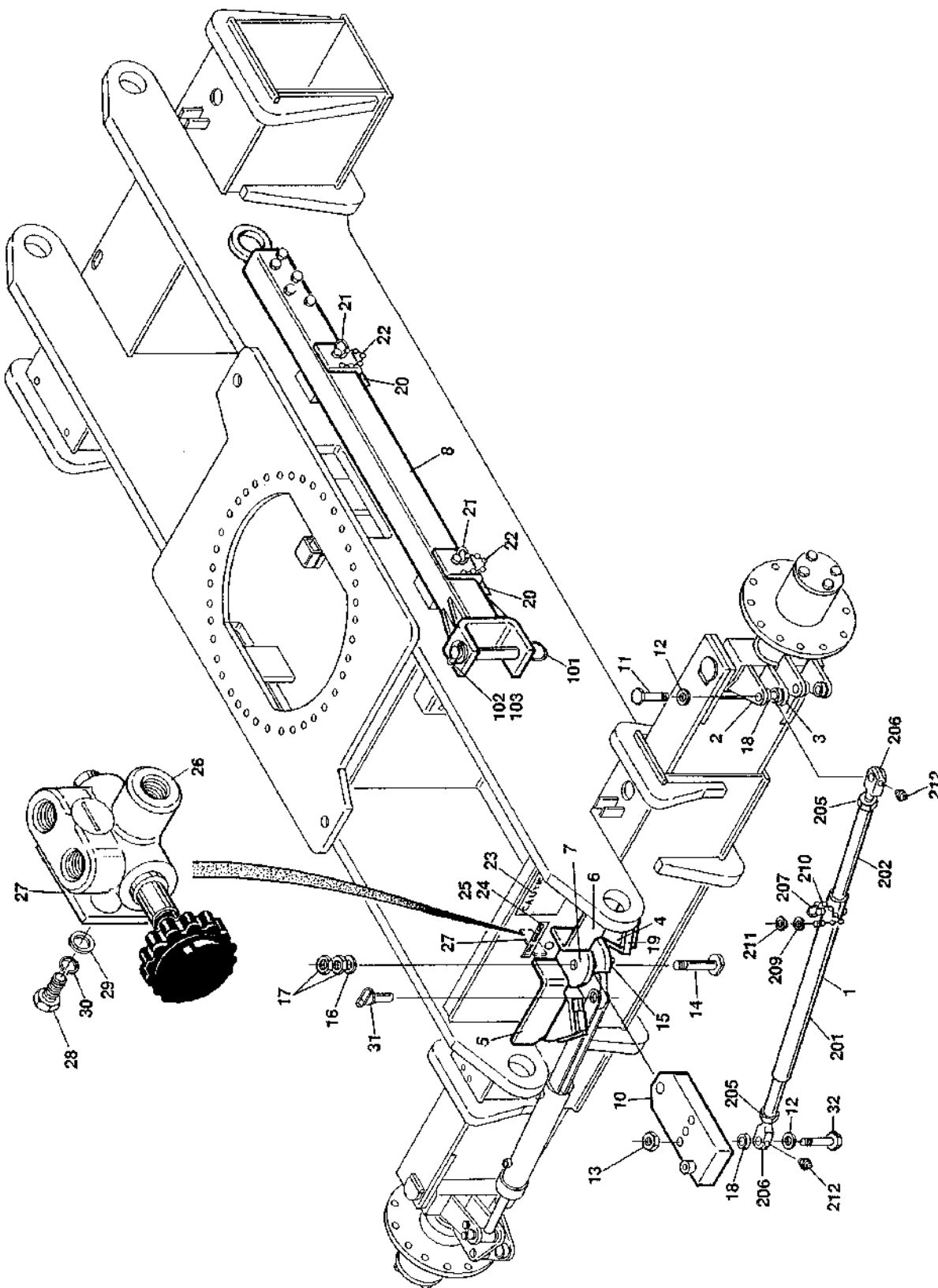

SECTION 1 FRAME

FIGURE 1-8. TOW PACKAGE INSTALLATIONS

FIG & ITEM #	PART NUMBER	DESCRIPTION	QTY.	REV.
	0252787	TOW PACKAGE INSTALLATION	Ref.	9/G
1	0252788	Steering Link Assembly (Includes Items 201-212)	1	
2	3536023	Lug, Steering - Plain (Prior to S/N 47309)	1	
3	3536028	Lug, Steering - Tapped (Prior to S/N 47309)	1	
4	3536024	Plate, Stop	4	
5	3536025	Gusset - Right	1	
6	3536026	Gusset - Left	1	
7	3536027	Lug - Center	2	
8	0251221	Tow Bar Assembly (Includes Items 101-103)	1	
9	Not Used			
10		Hitch Options:	1	
	2620022	Prior to S/N 31729		
	2620043	S/N 31729 to Present		
11	0630439	Bolt 1"- 8NC x 5" (Grade 8)	1	
12	4712600	Flatwasher 1"	2	
13		Nut 1"- 8NC Options:	2	
	3312601	Prior to S/N 33983		
	3312602	S/N 33983 to Present		
14	3420860	Pin	1	
15	2880410	Key	1	
16	4753000	Flatwasher 1 1/4"	2	
17	3323002	Nut, Jam 1 1/4"- 12NF	2	
18	0961668	Bushing (Prior to S/N 47309)	3	
19	0561022	Block, Stop	2	
20	4841055	Mount, Tow Bar	2	
21	3420292	Pin, Quick Release	2	
22	1260017	Chain	16in/41cm	
23		Decal - Caution Options:	1	
	3250840	Prior to May 1994		
	1702305	May 1994 to Present		
24	3250872	Nameplate - Tow Select	1	
25	3820001	Rivet	4	
26	4640261	Valve, Select	1	
27	0900479	Bracket	1	
28	0641507	Bolt 5/16"-18NC x 7/8"	2	
29	4751500	Flatwasher 5/16"	2	
30	4761500	Lockwasher 5/16"	2	
31	3421892	Pin, Clevis	1	
32	0642644	Bolt 1"- 8NC x 5 1/2" (Prior to S/N 33983)	1	
	0630439	Bolt 1"- 8NC x 5 (S/N 33983 to S/N 44508)	1	
	3900146	Bolt 1"- 8NC x 5 (S/N 44508 to Present)	1	
	0232121	TOW BAR ASSEMBLY	Ref.	
101	3420447	Pin, Tow	1	
102	4740036	Flatwasher, Special	1	
103	3420372	Pin, Cotter	1	

SECTION 1 FRAME

SECTION 1 FRAME

FIGURE 1-8. TOW PACKAGE INSTALLATIONS (CONTINUED)

FIG & ITEM #	PART NUMBER	DESCRIPTION	QTY.	REV.
	0252788	STEERING LINK ASSEMBLY	Ref.	A
201	4844277	Tube, Steer Link - Outer	1	
202	4844276	Tube, Steer Link - Inner	1	
203	Not Used			
204	Not Used			
205	3323002	Nut, Jam 1 1/4"-12NF	2	
206	0560605	Block, Tie Rod	2	
207	3420620	Pin	1	
208	Not Used			
209	4761400	Lockwasher 1/4"	1	
210	1260017	Chain	6in/15cm	
211	3311401	Nut 1/4"-20NC	1	
212	2160003	Fitting, Grease - 45°	2	

SECTION 2 TURNTABLE

TABLE OF CONTENTS		
FIGURE	DESCRIPTION	PAGE
2-1	TURNTABLE, BOOM AND CUTOFF SWITCH INSTALLATIONS (4620044 Turntable Machines)	2-2
2-2	TURNTABLE, BOOM AND CUTOFF SWITCH INSTALLATIONS (4620078 Turntable Machines)	2-6
2-3	CONTROL VALVES AND TILT INDICATOR INSTALLATIONS	2-10
2-4	CONTROL VALVE ASSEMBLY - VICKERS (Prior to October 1994)	2-14
2-5	CONTROL VALVE ASSEMBLY - VICKERS (October 1994 to Present)	2-18
2-6	CONTROL VALVE ASSEMBLY - BANG-BANG WITH DUMP SECTION (Prior to June 1995)	2-22
2-7	CONTROL VALVE ASSEMBLY - BANG-BANG WITH DUMP SECTION (June 1995 to Present)	2-26
2-8	ACCESSORY VALVE ASSEMBLY (Miller) (Machines Built Through 1989)	2-30
2-9	ACCESSORY VALVE ASSEMBLY (Machines Built 1990 to Present)	2-32
2-10	CONTROL VALVE ASSEMBLY - 1 SECTION BANG-BANG (100HX+10/110HXER Machines)	2-34
2-11	SWING DRIVE, BEARING AND LOCK INSTALLATIONS	2-36
2-12	SWING MOTOR ASSEMBLY - Nichols	2-38
2-13	SWING BRAKE ASSEMBLY (Prior to April 1992)	2-40
2-14	SWING BRAKE ASSEMBLY (April 1992 to Present)	2-44
2-15	SWING HUB ASSEMBLY	2-48
2-16	ROTARY COUPLING AND COLLECTOR RING ASSEMBLY AND INSTALLATION	2-50
2-17	DEUTZ ENGINE INSTALLATION WITHOUT NOISE REDUCTION (Built Prior to February 1992)	2-54
2-18	DEUTZ ENGINE INSTALLATION WITH NOISE REDUCTION (Built February 1992 to Present)	2-60
2-19	ADECO THROTTLE COMPONENTS INSTALLATION - DEUTZ ENGINE MACHINES	2-68
2-20	GENERATOR INSTALLATION - DEUTZ ENGINE MACHINES	2-70
2-21	PUMP COUPLING INSTALLATION	2-72
2-22	MAIN PUMP ASSEMBLY	2-74
2-23	TANKS INSTALLATION	2-76
2-24	GROUND CONTROLS INSTALLATION	2-80
2-25	LOAD MANAGEMENT INSTALLATION	2-86
2-26	HOODS AND ALARM INSTALLATION (Machines with 4620044 Turntable)	2-88
2-27	HOODS AND ALARM INSTALLATION (Machines with 4620078 Turntable)	2-92

SECTION 2 TURNTABLE

FIGURE 2-1. TURNTABLE, BOOM AND CUTOUT SWITCH INSTALLATIONS (4620044 TURNTABLE MACHINES)

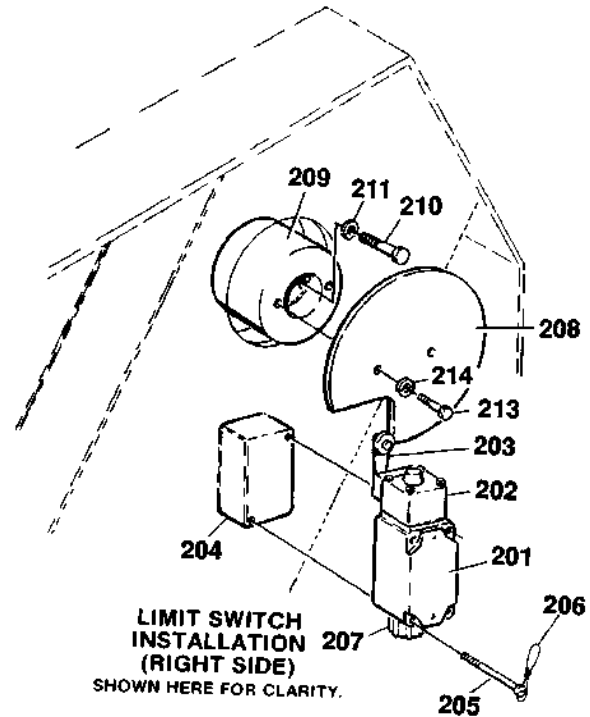
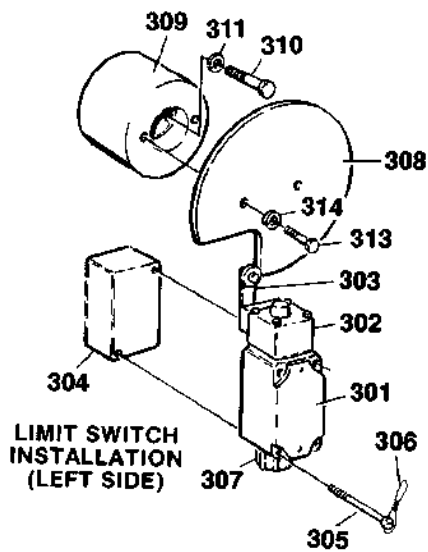
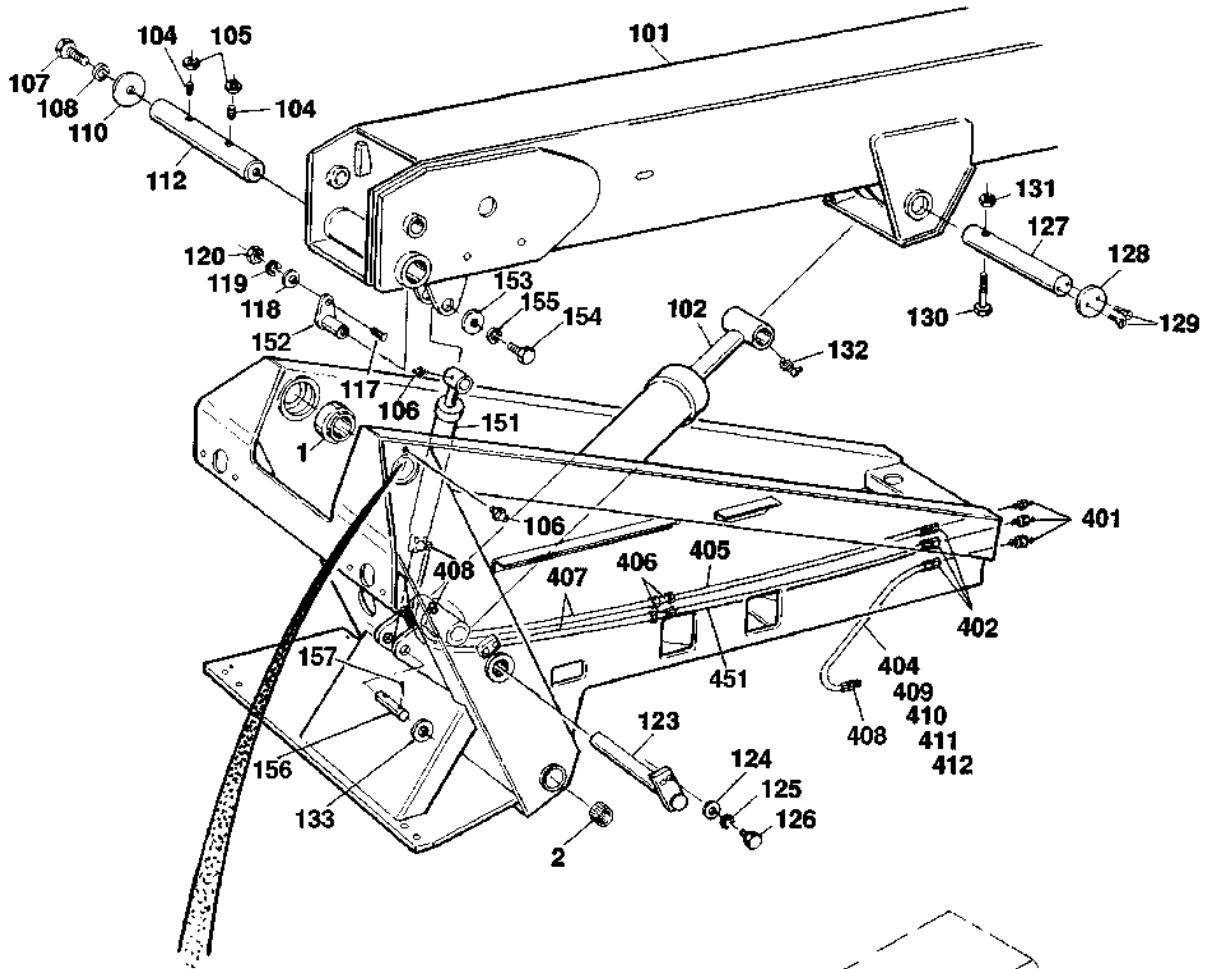

SECTION 2 TURNTABLE

FIGURE 2-1. TURNTABLE, BOOM AND CUTOUT SWITCH INSTALLATIONS (4620044 TURNTABLE MACHINES)

FIG & ITEM #	PART NUMBER	DESCRIPTION	QTY.	REV.
	4620044	TURNTABLE	1	
		Note: Used on machines built through May 1992		
1	0252852	Boom Pivot Assembly	2	
	0960594	Bushing, Self-Aligning (1 Per Assembly)	2	
2	0961392	Bushing, Bronze (Base Pivot)	2	
		BOOM AND CYLINDERS INSTALLATION	Ref.	
101		Boom Assembly (See Section 3 for Breakdown)	1	
102	1682034	Lift Cylinder Assembly (See Section 5 for Breakdown) (Prior to May 1992)	1	
	1682587	Lift Cylinder Assembly (See Section 5 for Breakdown) (May 1992 to Present)	1	
103	Not Used			
104	3951814	Setscrew 1/2"-13NC x 1 3/4"	2	
105	3311802	Nut, Jam 1/2"-13NC	2	
106	2160002	Fitting, Grease	3	
107	0681812	Bolt 1/2"-13NC	4	
108	4740171	Washer, Special Hardened	4	
109	0100019	Loctite #271 (Not Shown)	A/R	
110	1120368	Cap, Boom Pivot	2	
111	Not Used			
112	3421555	Pin, Boom Pivot	1	
113 to 116	Not Used			
117	4300038	Stud (Welded on Part)	1	
118	4751500	Flatwasher 5/16"	1	
119	4761500	Lockwasher 5/16"	1	
120	3311501	Nut 5/16"-18NC	1	
121	Not Used			
122	Not Used			
123	3421676	Pin, Bottom Lift Cylinder	1	
124	4712200	Flatwasher 3/4"	2	
125	4762200	Lockwasher 3/4"	2	
126	0682213	Bolt 3/4"-10NC x 1 5/8" (Grade 8)	2	
127	3421678	Pin, Top Lift Cylinder	1	
128	4740361	Washer, Special	2	
129	3900159	Screw, Countersunk 1/2"-13NC x 3/4"	4	
130	0641840	Bolt 1/2"-13NC x 5"	1	
131	3311805	Locknut 1/2"-13NC	1	
132	2160001	Fitting, Grease - 90°	1	
133	4740040	Flatwasher, Special	2	

SECTION 2 TURNTABLE

SECTION 2 TURNTABLE

FIGURE 2-1. TURNTABLE, BOOM AND CUTOFF SWITCH INSTALLATIONS (4620044 TURNTABLE MACHINES) (CONTINUED)

FIG & ITEM #	PART NUMBER	DESCRIPTION	QTY.	REV.
		BOOM INSTALLATION (VARIABLE PARTS)	Ref.	
	0250612	110HX Prior To Early 1990	Ref.	—
	0251019	110HX Early 1990 To May 1992	Ref.	D
	0239863	110HXER Prior To Early 1990	Ref.	D
	0251018	110HXER Early 1990 To May 1992	Ref.	C
151		Master Cylinder Assembly Options (See Section 5 for Breakdown):	1	
	1681978	110HX		
	1681580	110HXER		
152		Pin Options:	1	
	3421586	110HX		
	0236548	110HXER		
153		Flatwasher, Special Options:	A/R	
	Not Required	110HX	0	
	4740006	110HXER	1	
154		Bolt 3/8"-16NC x 1" Options:	1	
	Not Required	110HX		
	0641608	110HXER		
155		Lockwasher 3/8" Options:	3	
	Not Required	110HX		
	4761600	110HXER		
156		Pin Options:	1	
	3421561	110HX		
	3420085	110HXER		
157		Pin, Cotter 3/16" x 2 1/2" Options:	2	
	Not Required	110HX		
	3450610	110HXER		
	0251007	HORIZONTAL CUTOFF LIMIT SWITCH INSTALLATION (RIGHT SIDE)	Ref.	2/B
201	4360277	Switch, Limit	1	
202	4360236	Head, Actuator	1	
203	4360278	Roller and Arm	1	
204	0560984	Block, Switch Mounting	1	
205	3900168	Bolt, Socket Head #10-24NC Special	2	
206	4920140	Lockwire	1	
207	4460052	Connector, Strain Relief	1	
208	1100048	Cam	1	
209	1120372	Cap	1	
210	0681812	Bolt 1/2"-13NC x 1 1/2" (Grade 8)	2	
211	4740171	Washer, Special Hardened	2	
212	Not Used			
213	0641408	Bolt 1/4"-20NC x 1"	2	
214	4761400	Lockwasher 1/4"	2	
	0100019	----- Loctite #271	A/R	

SECTION 2 TURNTABLE

FIGURE 2-1. TURNTABLE, BOOM AND CUTOUT SWITCH INSTALLATIONS (4620044 TURNTABLE MACHINES) (CONTINUED)

FIG & ITEM #	PART NUMBER	DESCRIPTION	QTY.	REV.
	0251006	8 METER CUTOUT LIMIT SWITCH INSTALLATION (DUTCH AND GERMAN SPECS PRIOR TO S/N 28224) (LEFT SIDE)	Ref.	B
301	4360277	Switch, Limit	1	
302	4360236	Head, Actuator	1	
303	4360278	Roller and Arm	1	
304	0560984	Block, Switch Mounting	1	
305	3900168	Bolt, Socket Head #10-24NC Special	2	
306	4920140	Lockwire	1	
307	4460052	Connector, Strain Relief	1	
308	1100047	Cam	1	
309	1120372	Cap	1	
310	0681812	Bolt 1/2"-13NC x 1 1/2" (Grade 8)	2	
311	4740171	Washer, Special Hardened	2	
312	Not Used			
313	0641408	Bolt 1/4"-20NC x 1"	2	
314	4761400	Lockwasher 1/4"	2	
	0100019	Loctite #271	A/R	
		LUBE LINES INSTALLATION	Ref.	
	0239843	110HX & 100HX	Ref.	A
	0239844	110HXER	Ref.	3
401	2160002	Fitting, Grease	3	
402	2220001	Fitting	3	
403 to 404	Not Used			
405	2750807	Hose	1	
406	2200261	Fitting, Nipple	2	
407	2750527	Hose	2	
408	2220063	Fitting	3	
409	4300031	Stud (Welded on Part)	1	
410	4761400	Lockwasher 1/4"	1	
411	3311401	Nut 1/4"-20NC	1	
412	1320040	Clamp, Insulated	1	
413 to 450	Not Used			
451		Hose Options:	1	
	2750528	110HX & 100HX		
	2751032	110HXER		
452		Hose Options:	1	
	2750529	110HX & 100HX		
	2750528	110HXER		

SECTION 2 TURNTABLE

FIGURE 2-2. TURNTABLE, BOOM AND CUTOUT SWITCH INSTALLATIONS (4620078 TURNTABLE MACHINES)

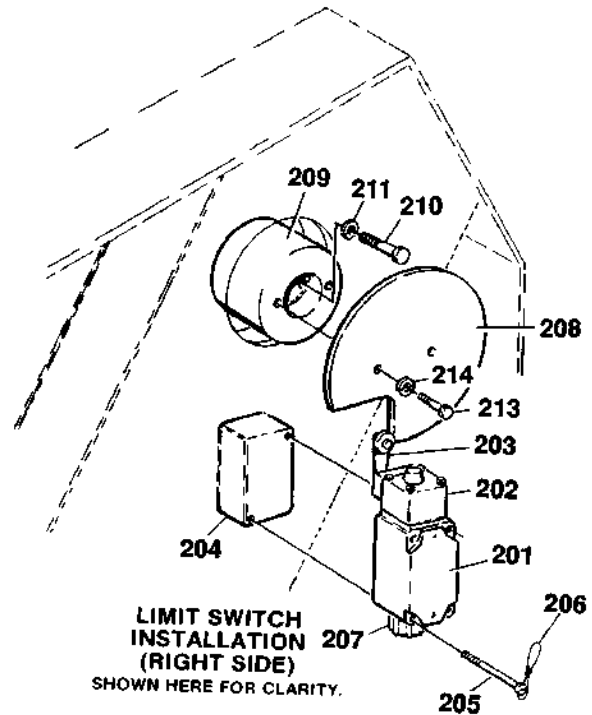
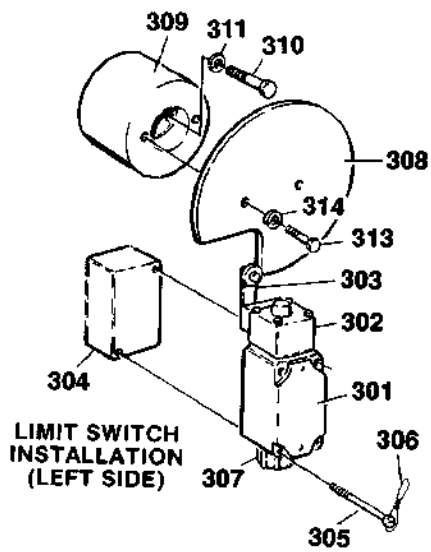
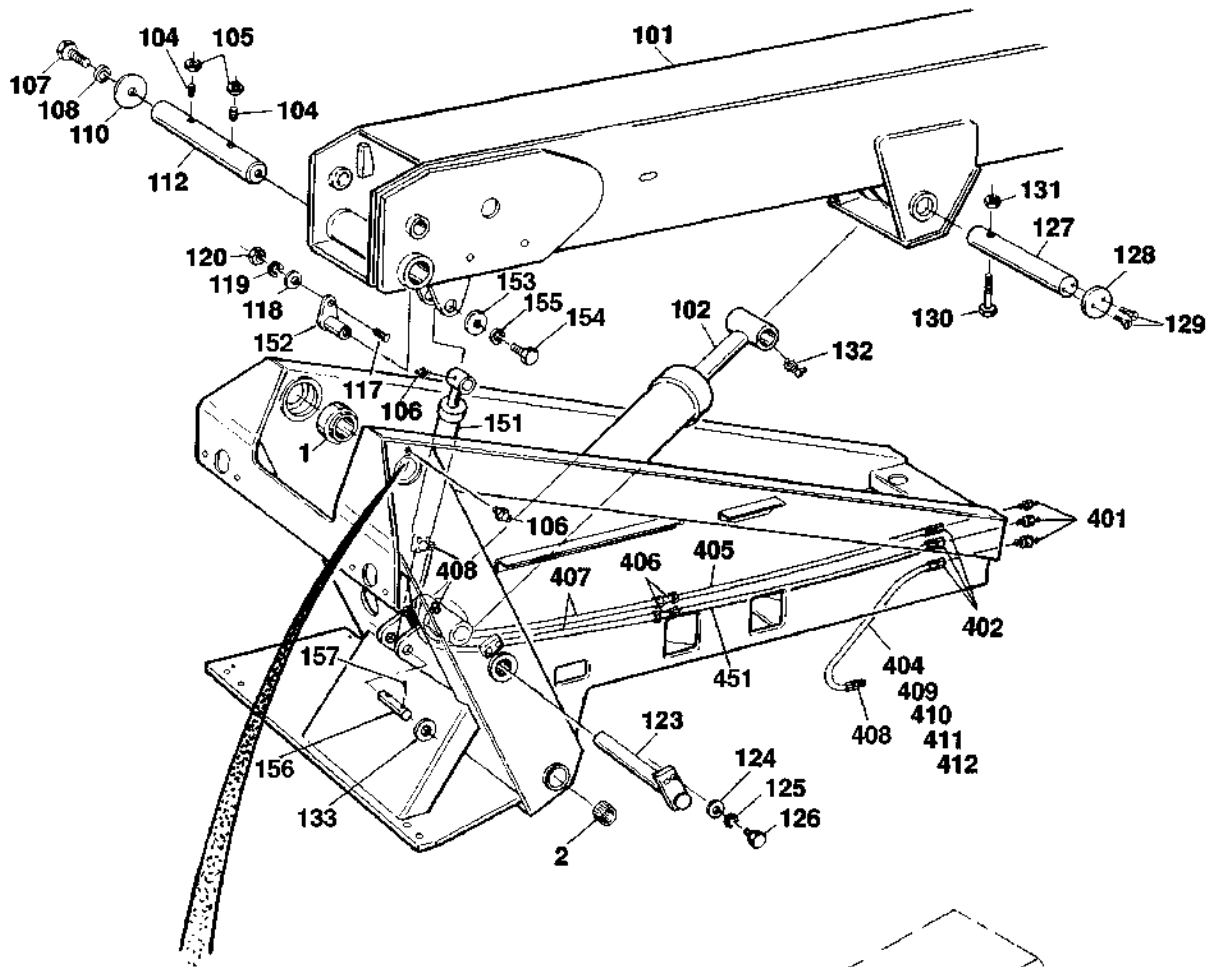

SECTION 2 TURNTABLE

FIGURE 2-2. TURNTABLE, BOOM AND CUTOUT SWITCH INSTALLATIONS (4620078 TURNTABLE MACHINES)

FIG & ITEM #	PART NUMBER	DESCRIPTION	QTY.	REV.
	4620078	TURNTABLE Note: Used on machines built May 1992 to Present.	1	
1	0252852	Boom Pivot Assembly	2	
	0960594	Bushing, Self-Aligning (1 Per Assembly)	2	
2	0961392	Bushing, Bronze (Base Pivot)	2	
		BOOM AND CYLINDERS INSTALLATIONS	Ref.	
	0252921	100HX Standard Machine	Ref.	5
	0252923	100HX Machine with Chip Covers	Ref.	5
	0252916	110HX Standard Machine	Ref.	4
	0252919	110HX Machine with Chip Covers	Ref.	4
	0252855/0252857	110HXER & 110HX+10 Standard Machine	Ref.	2/C
	0252934/0252930	110HXER & 110HX+10 Machine withChip Covers	Ref.	2/C
101		Boom Assembly (See Section 3 for Breakdown)	1	
102	1682630	Lift Cylinder Assembly (See Section 5 for Breakdown)	1	
103	Not Used			
104	3952014	Setscrew 5/8"-11NC x 1 3/4"	2	
105	3312002	Nut, Jam 5/8"-11NC	2	
106	2160002	Fitting, Grease	3	
107	0681812	Bolt 1/2"-13NC	4	
108	4740171	Washer, Special Hardened	4	
109	0100019	Loctite #271 (Not Shown)	A/R	
110	1120368	Cap, Boom Pivot	2	
111	Not Used			
112	3421555	Pin, Boom Pivot	1	
113 to 116	Not Used			
117	4300034	Stud (Welded on Part)	1	
118	4751600	Flatwasher 3/8"	1	
119	4761600	Lockwasher 3/8"	1	
120	3311601	Nut 3/8"-16NC	1	
121 to 122	Not Used			
123	3421676	Pin, Bottom Lift Cylinder	1	
124	4712200	Flatwasher 3/4"	2	
125	4762200	Lockwasher 3/4"	2	
126	0682213	Bolt 3/4"-10NC x 1 5/8" (Grade 8)	2	
127	3421678	Pin, Top Lift Cylinder	1	
128	4740361	Washer, Special	2	
129	3900159	Screw, Countersunk 1/2"-13NC x 3/4"	4	
130	0641840	Bolt 1/2"-13NC x 5"	1	
131	3311805	Locknut 1/2"-13NC	1	
132	2160001	Fitting, Grease - 90°	1	
133	4740040	Flatwasher, Special	2	
134 to 150	Not Used			

SECTION 2 TURNTABLE

SECTION 2 TURNTABLE

FIGURE 2-2. TURNTABLE, BOOM AND CUTOFF SWITCH INSTALLATIONS (4620078 TURNTABLE MACHINES) (CONTINUED)

FIG & ITEM #	PART NUMBER	DESCRIPTION	QTY.	REV.
151		Master Cylinder Assembly Options (See Section 5 for Breakdown):	1	
	1681978	100HX & 110HX		
	1681580	110HX+10 & 110HXER		
152		Pin Options:	1	
	3421586	100HX & 110HX		
	0236548	110HX+10 & 110HXER		
153		Flatwasher, Special Options:	A/R	
	Not Required	100HX & 110HX	0	
	4740006	110HX+10 & 110HXER	1	
154		Bolt 3/8"-16NC x 1" Options:	1	
	Not Required	100HX & 110HX		
	0641608	110HX+10 & 110HXER		
155		Lockwasher 3/8" Options:	3	
	Not Required	100HX & 110HX		
	4761600	110HX+10 & 110HXER		
156		Pin Options:	1	
	3422068	100HX & 110HX		
	3420085	110HX+10 & 110HXER		
157		Pin, Cotter 3/16" x 2 1/2" Options:	2	
	Not Required	100HX & 110HX		
	3450610	110HX+10 & 110HXER		
	0251007	HORIZONTAL CUTOFF LIMIT SWITCH INSTALLATION (RIGHT SIDE)	Ref.	2
201	4360277	Switch, Limit	1	
202	4360236	Head, Actuator	1	
203	4360278	Roller and Arm	1	
204	0560984	Block, Switch Mounting	1	
205	3900168	Bolt, Socket Head #10-24NC Special	2	
206	4920140	Lockwire	1	
207	4460052	Connector, Strain Relief	1	
208	1100048	Cam	1	
209	1120372	Cap	1	
210	0681812	Bolt 1/2"-13NC x 1 1/2" (Grade 8)	2	
211	4740171	Washer, Special Hardened	2	
212	Not Used			
213	0641408	Bolt 1/4"-20NC x 1"	2	
214	4761400	Lockwasher 1/4"	2	
	0100019	----- Loctite #271	A/R	

SECTION 2 TURNTABLE

FIGURE 2-2. TURNTABLE, BOOM AND CUTOUT SWITCH INSTALLATIONS (4620078 TURNTABLE MACHINES) (CONTINUED)

FIG & ITEM #	PART NUMBER	DESCRIPTION	QTY.	REV.
	0251006	8 METER CUTOUT LIMIT SWITCH INSTALLATION (DUTCH AND GERMAN SPECS PRIOR TO S/N 28224) (LEFT SIDE)	Ref.	
301	4360277	Switch, Limit	1	
302	4360236	Head, Actuator	1	
303	4360278	Roller and Arm	1	
304	0560984	Block, Switch Mounting	1	
305	3900168	Bolt, Socket Head #10-24NC Special	2	
306	4920140	Lockwire	1	
307	4460052	Connector, Strain Relief	1	
308	1100047	Cam	1	
309	1120372	Cap	1	
310	0681812	Bolt 1/2"-13NC x 1 1/2" (Grade 8)	2	
311	4740171	Washer, Special Hardened	2	
312	Not Used			
313	0641408	Bolt 1/4"-20NC x 1"	2	
314	4761400	Lockwasher 1/4"	2	
	0100019	Loctite #271	A/R	
		LUBE LINES INSTALLATION	Ref.	
	0239843	110HX & 100HX	Ref.	A
	0239844	110HXER	Ref.	3
401	2160002	Fitting, Grease	3	
402	2220001	Fitting	3	
403 to 404	Not Used			
405	2750807	Hose	1	
406	2200261	Fitting, Nipple	2	
407	2750527	Hose	2	
408	2220063	Fitting	3	
409	4300031	Stud (Welded on Part)	1	
410	4761400	Lockwasher 1/4"	1	
411	3311401	Nut 1/4"-20NC	1	
412	1320040	Clamp, Insulated	1	
413 to 450	Not Used			
451		Hose Options:	1	
	2750528	110HX & 100HX		
	2751032	110HXER		
452		Hose Options:	1	
	2750529	110HX & 100HX		
	2750528	110HXER		

SECTION 2 TURNTABLE

FIGURE 2-3. CONTROL VALVES AND TILT INDICATOR INSTALLATIONS

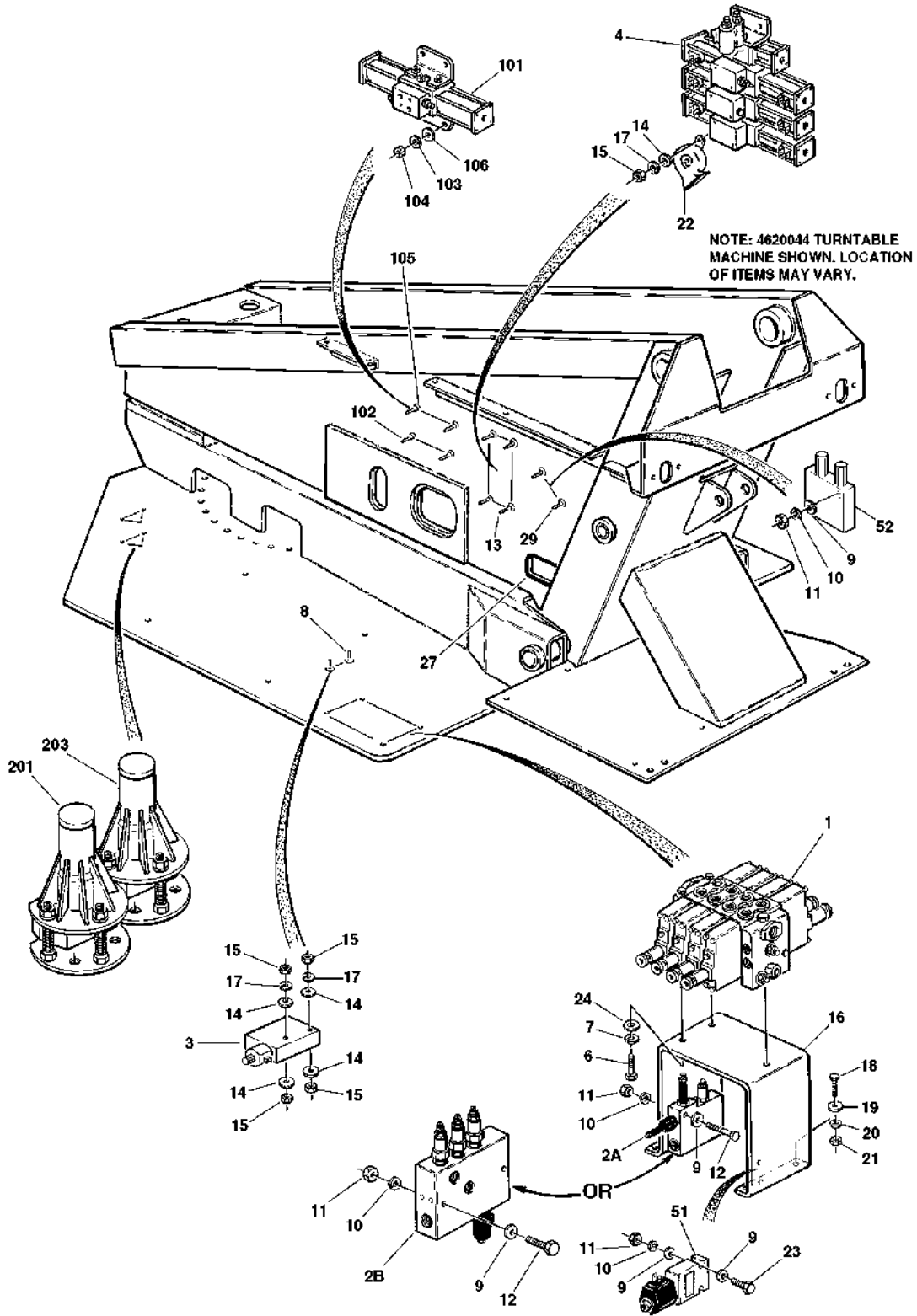

SECTION 2 TURNTABLE

FIGURE 2-3. CONTROL VALVES AND TILT INDICATOR INSTALLATIONS

FIG & ITEM #	PART NUMBER	DESCRIPTION	QTY.	REV.
		CONTROL VALVES INSTALLATION	Ref.	
	0239913	4620044 Turntable Machines Built Prior To May 1990	Ref.	E
	0251093	4620044 Turntable Machines Built May 1990 To May 1992	Ref.	C
	0254061	4620078 Turntable Machines	Ref.	6
1		Control Valve Assembly (Vickers) Options:	1	
	4640524	Prior to October 1994 (See Figure 2-4 for Breakdown)		
	4640914	October 1994 to Present (See Figure 2-5 for Breakdown)		
2		Accessory Valve Options:		
2A	4640535	Accessory Valve Assembly (Machines Built Through 1989) (See Figure 2-8 for Breakdown) Note: 4640535 Accessory Valve is no longer available as a complete assembly. See Figure 2-8 for Individual parts.	1	
2B	4640580	Accessory Valve Assembly (Machines built 1990 to September 1991) (See Figure 2-9 for Breakdown) Note: 4640580 Accessory Valve is no longer available as a complete assembly. See Figure 2-9 for Individual parts.	1	
2B	4640716	Accessory Valve Assembly (Machines Built September 1991 to Present) (See Figure 2-9 for Breakdown) Note: Complete 4640716 Valves are available. See Figure 2-9 for Individual parts.	1	
3	4640360	Dump Valve Assembly	1	
	7009745	Coil (Vickers/Modular Controls Version)	1	
	7004289	Solenoid Cartridge Less Coil (Vickers/Modular Controls Version)	1	
	7003635	Check Valve Cartridge (Vickers/Modular Controls Version)	1	
	7004368	Coil (Hydraforce Version)	1	
	7012910	Solenoid Cartridge Less Coil (1989 to Present) (Hydraforce Version)	1	
	7010635	Solenoid Cartridge Less Coil (Prior to 1989) (Hydraforce Version)	1	
	7009798	Check Valve Cartridge (Hydraforce Version)	1	
4		Control Valve Assembly (Bang-Bang) Options:	1	
	4640246	Prior to June 1995 (See Figure 2-6 for Breakdown)		
	4640941	June 1995 to Present (See Figure 2-7 for Breakdown)		
5	Not Used			
6	0641708	Bolt 7/16"-14NC x 1"	3	
7	4761700	Lockwasher 7/16"	3	
8	4300033	Stud (Welded on Part)	2	
9	4751400	Flatwasher 1/4"	A/R	
10	4761400	Lockwasher 1/4"	A/R	
11	3311401	Nut 1/4"-20NC	A/R	

SECTION 2 TURNTABLE

SECTION 2 TURNTABLE

FIGURE 2-3. CONTROL VALVES AND TILT INDICATOR INSTALLATIONS (CONTINUED)

FIG & ITEM #	PART NUMBER	DESCRIPTION	QTY.	REV.
12	0641526	Bolt 5/16"-18NC x 3 1/4"	2	
13	4300038	Stud (Welded on Part)	5	
14	4751500	Flatwasher 5/16"	9	
15	3311501	Nut 5/16"-18NC	11	
16	0901399	Bracket	1	
17	4761500	Lockwasher 5/16"	9	
18	0641616	Bolt 3/8"-16NC x 2"	4	
19	4751600	Flatwasher 3/8"	4	
20	4761600	Lockwasher 3/8"	4	
21	3311601	Nut 3/8"-16NC	4	
22	0140001	Horn	1	
23	0641418	Bolt 1/4"-20NC x 2 1/4"	2	
24	4751600	Flatwasher 3/8"	3	
25	1320041	Clamp	1	
26	0641408	Bolt 1/4"-20NC x 1"	1	
27	4060808	Flex-Guard	7.5ft/2.3m	
28	Not Used			
29	4300042	Stud (Welded on Part)	A/R	
30 to 50	Not Used			
51		Dump Valve Assembly Options: 4620044 Turntable Machine Built Prior to May 1990 Components:	1	
	4640513	Dump Valve Assembly	1	
	7003640	Coil (Modular Controls Version)	A/R	
	7004289	Cartridge Less Coil (Modular Controls Ver- sion)	A/R	
	2900503	Seal Kit (Modular Controls Version)	A/R	
	7000645	Coil (Hydraforce Version)	A/R	
	7012910	Cartridge Less Coil (Hydraforce Version)	A/R	
	2900756	Seal Kit (Hydraforce Version)	A/R	
	7022390	Nut (Attachs Coil to Cartridge)	1	
		4620044 Turntable Machine Built May 1990 to May 1992 Components:		
	4640543	Dump Valve Assembly	1	
	7009745	Coil (Modular Controls Version)	A/R	
	7004368	Coil (Hydraforce Version)	A/R	
		4620078 Turntable Machine Components:		
	4640543	Dump Valve Assembly	1	
	7009745	Coil (Modular Controls Version)	A/R	
	7004368	Coil (Hydraforce Version)	A/R	
52		Relief Valve Assembly Options:	1	
	Not Required	4620044 Turntable Machines		
	4640839	4620078 Turntable Machines		
	7012945	Cartridge, Replacement	2	

SECTION 2 TURNTABLE

FIGURE 2-3. CONTROL VALVES AND TILT INDICATOR INSTALLATIONS (CONTINUED)

FIG & ITEM #	PART NUMBER	DESCRIPTION	QTY.	REV.
		EXTEND-A-REACH VALVE INSTALLATION (110HXER & 100HX+10 ONLY)	Ref.	
	0239155	Prior To December 1989	Ref.	—
	0250618	December 1989 To Present	Ref.	3
101	4640519	Control Valve Assembly (See Figure 2-10 for Breakdown)	1	
102	4300038	Stud (Welded on Part)	2	
103	4761500	Lockwasher 5/16"	4	
104	3311501	Nut 5/16"-18NC	6	
105	4300070	Stud (Welded on Part)	2	
106	4751500	Flatwasher 5/16"	6	
	0251088	TILT INDICATOR INSTALLATION	Ref.	4
201	4360280	Sensor, Level (3°)	1	
202	2820022	Tubing, Vinyl (Not Shown)	A/R	
203	4360171	Sensor, Level (5°)	1	
204	4300106	Stud, Grooved (Not Shown)	2	

SECTION 2 TURNTABLE

FIGURE 2-4. CONTROL VALVES ASSEMBLY (VICKERS) (PRIOR TO OCTOBER 1994)

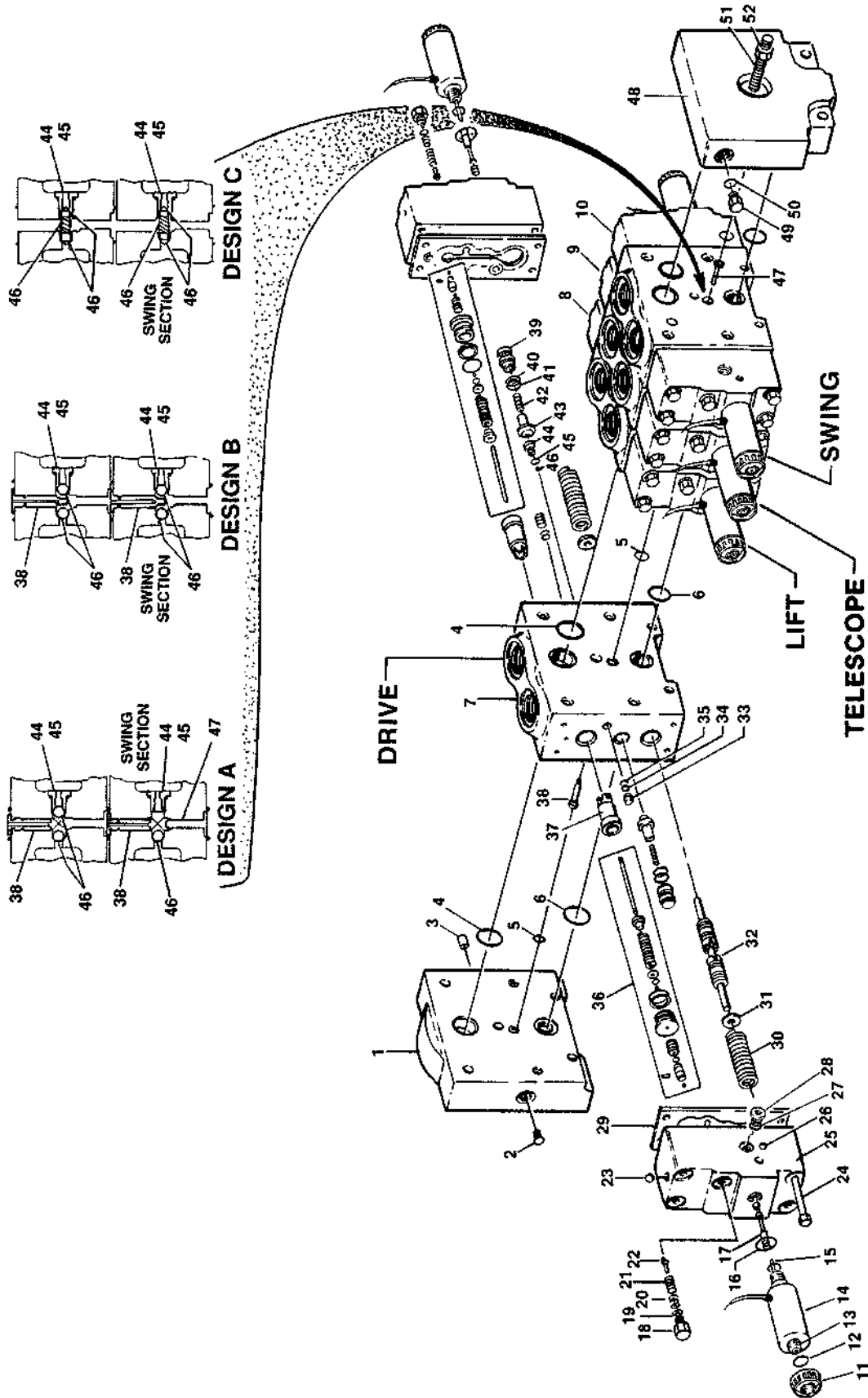

SECTION 2 TURNTABLE

FIGURE 2-4. CONTROL VALVES ASSEMBLY (VICKERS) (PRIOR TO OCTOBER 1994)

FIG & ITEM #	PART NUMBER	DESCRIPTION	QTY.	REV.
1	7006747	Inlet Body	1	
2	7006725	Setscrew	1	
3	7006733	Plug	1	
4	Kit	O-Ring	5	
5	Kit	O-Ring	5	
6	Kit	O-Ring	5	
7	7009350	Working Section - Complete (Drive) (4 Section)	1	
8	7006762	Working Section - Complete (Lift)	1	
9	7009351	Working Section - Complete (Telescope)	1	
10	7006763	Working Section - Complete (Swing)	1	
11	Use 7012325	Nut, Retaining (was p/n 7009317)	2	
12	Kit	O-Ring	2	
13	7009316	Core Tube (Includes O-Ring)	2	
14	7009315	Coil and Frame	2	
15	7009319	Pin	2	
16	Kit	O-Ring	2	
17	7006744	Spool	2	
18	7006726	Plug, Torque	2	
19	Kit	O-Ring	2	
20	7006728	Shim Kit	2	
21	7006729	Spring	2	
22	7006730	Poppet	2	
23	7006731	Ball	2	
24	7006745	Screw	8	
25		Cap, End (Not Sold Separately)	2	
26	7006746	Ball	2	
27	Kit	O-Ring	2	
28	7009323	Plug	2	
29	Kit	Gasket	2	
30	7009324	Spring	2	
31	7009325	Retainer	2	
32		Spool (Not Sold Separately)	1	
33	7006757	Seat	2	
34	Kit	Ring, Back-Up	2	
35	Kit	O-Ring	2	
36	7006732	Servo Stem Assembly	2	
37	7006737	Poppet	2	
38	7009321	Retainer (13/16"-2.1cm Length) (Design A)	1	
	7009363	Retainer (1 3/16"-3cm Length) (Design B)	1	
	Not Required	Retainer (Design C)		
	Kit	O-Ring	1	
39	7006752	Retainer	2	
40	Kit	Ring, Back-Up	2	
41	Kit	O-Ring	2	
42	7006773	Spring	2	
43	7006756	Poppet	2	
44	7006771	Plug, Torque	1	
45	Kit	O-Ring	1	

SECTION 2 TURNTABLE

SECTION 2 TURNTABLE

**FIGURE 2-4. CONTROL VALVES ASSEMBLY (VICKERS) (PRIOR TO OCTOBER 1994)
(CONTINUED)**

FIG & ITEM #	PART NUMBER	DESCRIPTION	QTY.	REV.
46	7006761	Ball (Design A - All Sections Except Swing)	2	
	7006761	Ball (Design A - Swing Section)	1	
	7006761	Ball (Design B - All Sections)	2	
	7009369	Poppet (Design C - All Sections)	2	
	7009368	Spring (Design C - All Sections)	1	
	47	7006777	Pin, Solid (Design A - Swing Section Only)	1
Not Required		Pin, Solid (Design B and Design C)		
48	7006780	Cover End	1	
49	7006778	Plug, Torque	1	
50	Kit	O-Ring	1	
51	7009329	Rod, Tie	3	
52	7006782	Nut	6	
	7009330	Seal Kit (Includes Items 4, 5, 6, 12, 16, 27, 34, 35, 38, 40,41,45, 50 and Servo Stem O-Rings)	4	
	7009395	Seal Kit - Valve Face (Includes Items 4,5 and 6)	5	

SECTION 2 TURNTABLE

FIGURE 2-4. CONTROL VALVES ASSEMBLY (VICKERS) (PRIOR TO OCTOBER 1994)
(CONTINUED)

FIG & ITEM #	PART NUMBER	DESCRIPTION	QTY.	REV.

**S
E
C
T
I
O
N

2

T
U
R
N
T
A
B
L
E**

SECTION 2 TURNTABLE

FIGURE 2-5. CONTROL VALVES ASSEMBLY (VICKERS) (OCTOBER 1994 TO PRESENT)

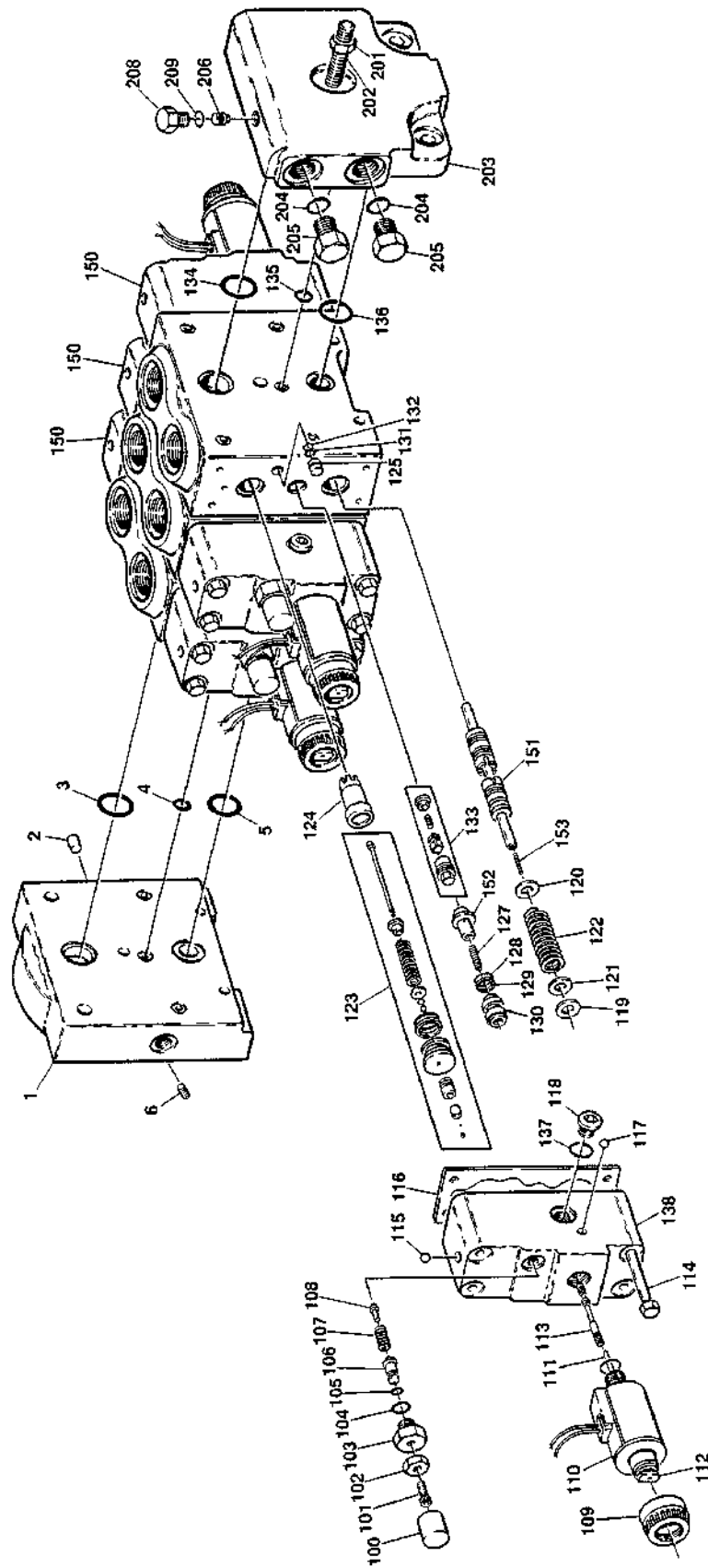

SECTION 2 TURNTABLE

FIGURE 2-5. CONTROL VALVES ASSEMBLY (VICKERS) (OCTOBER 1994 TO PRESENT)

FIG & ITEM #	PART NUMBER	DESCRIPTION	QTY.	REV.
	4640914	VICKERS VALVE ASSEMBLY - 4 SECTION	Ref.	—
		Inlet Section	Ref.	
1	7006724	Inlet Body	1	
2	7006733	Plug	1	
3	Kit	O-Ring	1	
4	Kit	O-Ring	1	
5	Kit	O-Ring	1	
6	7006725	Setscrew	1	
		Working Sections (Standard Parts)	Ref.	
100	Kit	Cap (2 Per Section)	A/R	
101	7012319	Screw (2 Per Section)	A/R	
102	Kit	Nut (2 Per Section)	A/R	
103	Kit	Plug (2 Per Section)	A/R	
104	Kit	Packing (2 Per Section)	A/R	
105	7012322	Packing (2 Per Section)	A/R	
106	Kit	Piston (2 Per Section)	A/R	
107	Kit	Spring (2 Per Section)	A/R	
108	7006730	Poppet (2 Per Section)	A/R	
109	7012325	Nut, Retaining (2 Per Section)	A/R	
110	7012339	Coil (2 Per Section)	A/R	
111	7009319	Pin (2 Per Section)	A/R	
112	7012326	Core Tube Sub Assembly (2 Per Section)	A/R	
113	7012327	Spool	A/R	
114	7006745	Screw (8 Per Section)	A/R	
115	7006731	Ball	A/R	
116	7006748	Gasket	A/R	
117	7006746	Ball	A/R	
118	7009323	Plug (2 Per Section)	A/R	
119	7012330	Shim (A/R Per Section)	A/R	
120	7012329	Retainer (2 Per Section)	A/R	
121	7012328	Shim (A/R Per Section)	A/R	
122	7009324	Spring (2 Per Section)	A/R	
123	7009320	Stem Servo Sub Assembly (2 Per Section)	A/R	
124	7006737	Poppet (2 Per Section)	A/R	
125	7006757	Seat (2 Per Section)	A/R	
126	Not Used			
127	7006773	Spring (2 Per Section)	A/R	
128	Kit	O-Ring (2 Per Section)	A/R	
129	Kit	Back-up (2 Per Section)	A/R	
130	7009398	Retainer (2 Per Section)	A/R	
131	Kit	Back-up Ring (2 Per Section)	A/R	
132	Kit	O-Ring (2 per Section)	A/R	
133	7012333	Load Sense (2 Per Section)	A/R	
134	Kit	O-Ring (2 Per Section)	A/R	
135	Kit	O-Ring (2 Per Section)	A/R	
136	Kit	O-Ring (5 Per Section)	A/R	
137	Kit	O-Ring (2 Per Section)	A/R	
138	Not Serviced	Cap, End (2 Per Section)	A/R	

SECTION 2 TURNTABLE

SECTION 2 TURNTABLE

FIGURE 2-5. CONTROL VALVES ASSEMBLY (VICKERS) (OCTOBER 1994 TO PRESENT)

FIG & ITEM #	PART NUMBER	DESCRIPTION	QTY.	REV.
	7009330	Seal Kit (1 Per Section)	A/R	
	7012383	Piston/Spring Kit (Includes 1 each of 100, 102, 103, 106 and 107) (2 per Section)	A/R	
150		WORKING SECTION (VARIABLE PARTS)		
	7012332	Drive Section	Ref.	
	7012334	Lift & Telescope Section	Ref.	
	7012335	Swing Section	Ref.	
151		Spool Options:	1	
	7012331	Drive Section		
	7012331	Lift & Telescope Section		
	7012335	Swing Section		
152		Poppet Options:	A/R	
	7009399	Drive Section	2	
	7009397	Lift & Telescope Section (2 Per Spool)	A/R	
	7009399	Swing Section	2	
153		Piston Options:	A/R	
	Not Required	Drive Section	2	
	Not Required	Lift & Telescope Section (2 Per Spool)	A/R	
	7012300	Swing Section	2	
		OUTLET SECTION	Ref.	
201	7006782	Nut	6	
202	7009361	Rod, Tie	3	
203	7012337	Cover End	1	
204	Kit	O-Ring	2	
205	7006778	Plug	2	
206	7012338	Setscrew Orifice Sub-Assembly	1	
207	Kit	O-Ring	1	
208	7012336	Plug	1	
209	7006770	O-Ring	1	

SECTION 2 TURNTABLE

FIGURE 2-5. CONTROL VALVES ASSEMBLY (VICKERS) (OCTOBER 1994 TO PRESENT)

FIG & ITEM #	PART NUMBER	DESCRIPTION	QTY.	REV.

**S
E
C
T
I
O
N

2

T
U
R
N
T
A
B
L
E**

SECTION 2 TURNTABLE

FIGURE 2-6. CONTROL VALVE ASSEMBLY - BANG-BANG WITH DUMP SECTION (PRIOR TO JUNE 1995)

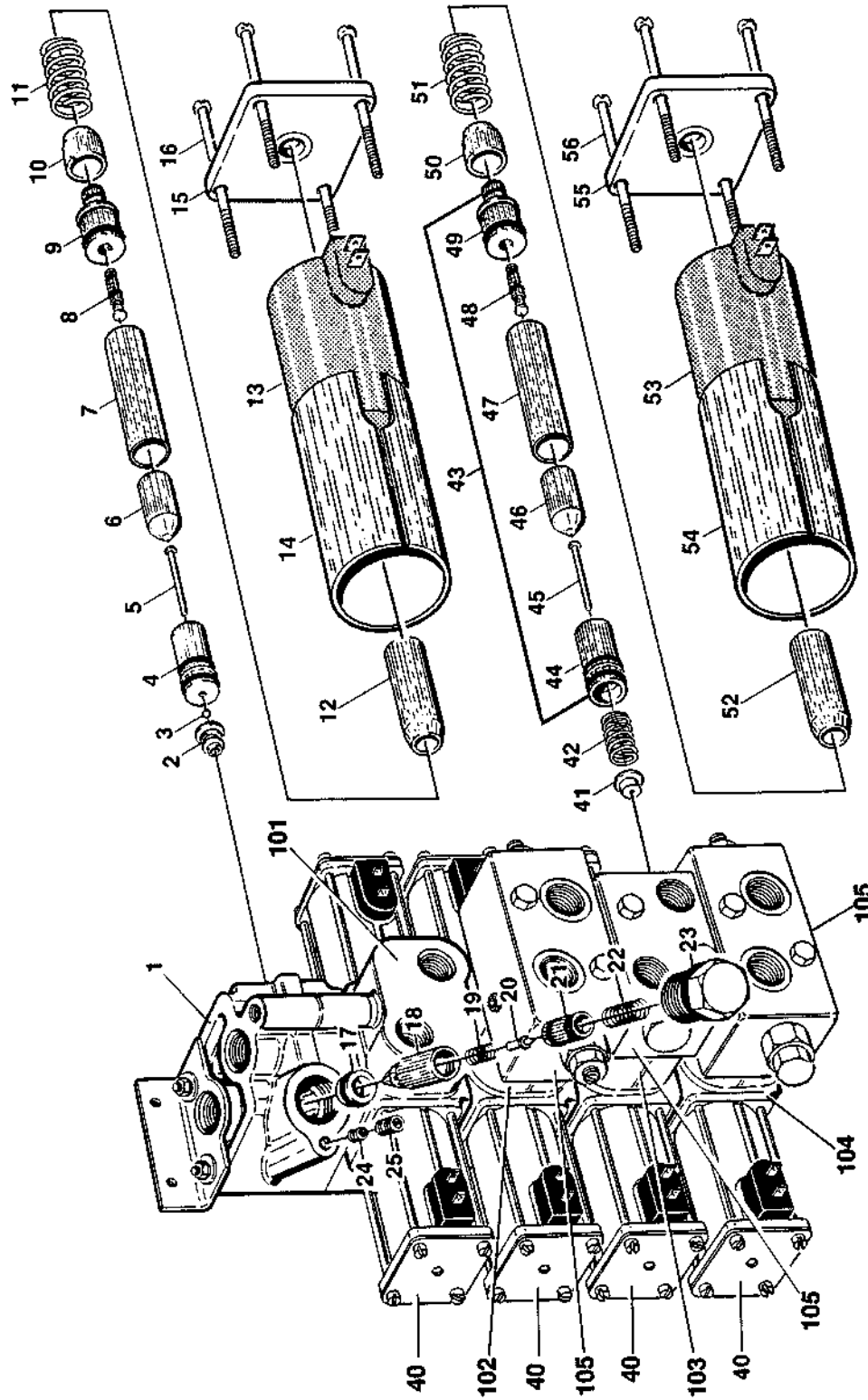

SECTION 2 TURNTABLE

FIGURE 2-6. CONTROL VALVE ASSEMBLY - BANG-BANG WITH DUMP SECTION (PRIOR TO JUNE 1995)

FIG & ITEM #	PART NUMBER	DESCRIPTION	QTY.	REV.
	4640246	VALVE ASSEMBLY - 3 SECTION	Ref.	A
1	7002304	DUMP SECTION	Ref.	
		Solenoid Assembly		
2	7004823	Seat	1	
	7002378	O-Ring	1	
3	7002229	Ball	1	
		Guide Tube Assembly	1	
4	7004822	Cone, Female	1	
	7004840	O-Ring	1	
5	7002346	Pin, Push	1	
6	7004839	Plunger	1	
7	7004838	Tube, Guide	1	
8	7004841	Pin, Push	1	
	7002342	O-Ring	1	
9	7002340	Guide, External Push Pin	1	
	7002337	O-Ring	1	
10	7004834	Sleeve, Inner Flux	1	
11	7002334	Spring	1	
12	7004835	Sleeve, Outer Flux	1	
13	7000417	Coil	1	
14	7004836	Case, Solenoid	1	
15	7002338	Plate, End	1	
	7002327	Nameplate	1	
16	7004837	Screw	4	
17	7002322	Seat	1	
	7004826	O-Ring	1	
		Main Relief (Poppet) Valve	1	
18	7002321	Case, Poppet	1	
19	7002328	Spring	1	
20	7002294	Poppet	1	
21	7002320	Seat, Adjustable	1	
	7004842	O-Ring	1	
22	7002329	Spring	1	
23	7002323	Plug	1	
	7000102	O-Ring	1	
24	7002326	Orifice	1	
25	7002324	Plug	1	
		WORKING SECTIONS (STANDARD PARTS)	Ref.	
40	7004859	Solenoid Assembly (2 Per Section) (Includes Items 43-56)	A/R	
41	7002274	Washer (7002315,7002316,7002317 Sections) (2 Per Section)	A/R	
	7003825	Washer (7003855 Sections) (2 Per Section)	A/R	
42	7002348	Spring (2 Per Section)	A/R	

SECTION 2 TURNTABLE

SECTION 2 TURNTABLE

FIGURE 2-6. CONTROL VALVE ASSEMBLY - BANG-BANG WITH DUMP SECTION (PRIOR TO JUNE 1995) (CONTINUED)

FIG & ITEM #	PART NUMBER	DESCRIPTION	QTY.	REV.
43	7002305	Guide Tube Assembly (1 Per Solenoid Assembly)	A/R	
44	7002345	Cone, Female (1 Per Solenoid Assembly)	A/R	
	Kit	O-Ring (1 Per Solenoid Assembly)	A/R	
	Kit	O-Ring (1 Per Solenoid Assembly)	A/R	
45	7002346	Pin, Push (1 Per Solenoid Assembly)	A/R	
46	7002344	Plunger (1 Per Solenoid Assembly)	A/R	
47	7000470	Tube, Guide (1 Per Solenoid Assembly)	A/R	
48	7002341	Pin, Actuator (1 Per Solenoid Assembly)	A/R	
	Kit	Ring, Quad (1 Per Solenoid Assembly)	A/R	
49	7002340	Guide, External Push Pin (1 Per Solenoid Assembly)	A/R	
	Kit	O-Ring (1 Per Solenoid Assembly)	A/R	
50	7002333	Sleeve, Inner Flux (1 Per Solenoid Assembly)	A/R	
51	7002334	Spring (1 Per Solenoid Assembly)	A/R	
52	7002336	Sleeve, Outer Flux (1 Per Solenoid Assembly)	A/R	
53	7000418	Coil (1 Per Solenoid Assembly)	A/R	
54	7002335	Case, Solenoid (1 Per Solenoid Assembly)	A/R	
55	7002338	Plate, End (1 Per Solenoid Assembly)	A/R	
56	7002339	Screw (4 Per Solenoid Assembly)	A/R	
		WORKING SECTION (VARIABLE PARTS)	Ref.	
		Note: Complete Sections listed below include items 40-56 and relief valve assembly when equipped		
101	7002315	Section #1 - Steer/Tele	1	
102	7002316	Section #2 - Level	1	
103	7002315	Section #3 - Steer/Tele	1	
104	Not Required	Section #4	0	
105		Relief Valve Options:	A/R	
	7000468	Crossover Relief Valve Assembly (Due to various suppliers, internal components are no longer field serviceable)		
	7002262	Dual Pilot Check Valve Assembly (Due to various suppliers, internal components are no longer field serviceable)	A/R	
	7000414	Seal Kit - Working Section	4	
	7000413	Seal Kit - Dump Section	1	

SECTION 2 TURNTABLE

FIGURE 2-6. CONTROL VALVE ASSEMBLY - BANG-BANG WITH DUMP SECTION (PRIOR TO JUNE 1995) (CONTINUED)

FIG & ITEM #	PART NUMBER	DESCRIPTION	QTY.	REV.

**S
E
C
T
I
O
N

2

T
U
R
N
T
A
B
L
E**

SECTION 2 TURNTABLE

FIGURE 2-7. CONTROL VALVE ASSEMBLY - BANG-BANG WITH DUMP SECTION (JUNE 1995 TO PRESENT)

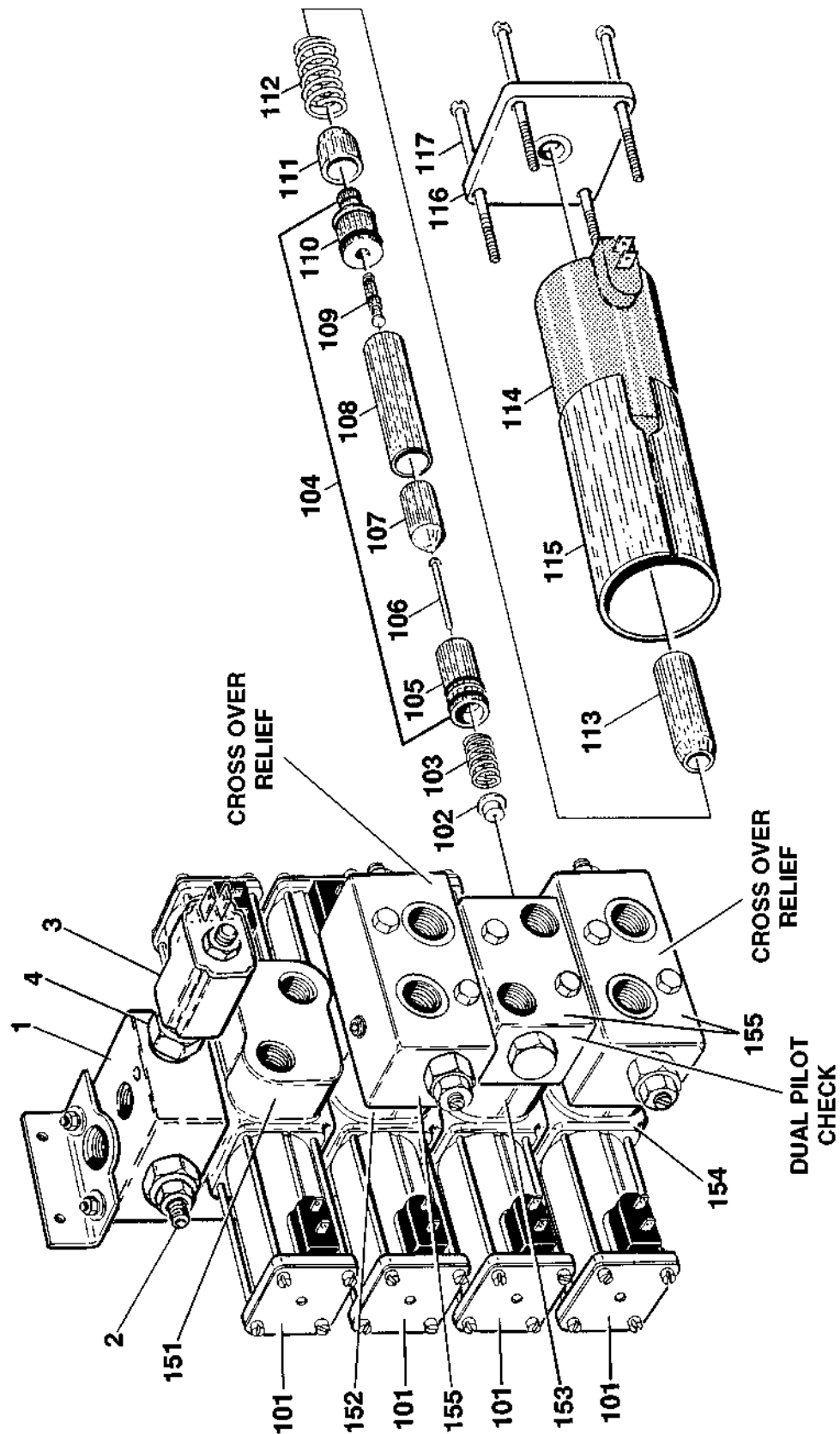

SECTION 2 TURNTABLE

FIGURE 2-7. CONTROL VALVE ASSEMBLY - BANG-BANG WITH DUMP SECTION (JUNE 1995 TO PRESENT)

FIG & ITEM #	PART NUMBER	DESCRIPTION	QTY.	REV.
	4640941	VALVE ASSEMBLY - 3 SECTION	Ref.	B
		DUMP SECTION ASSEMBLY	Ref.	
1	7002447	Dump Section - Complete	1	
2	7002448	Cartridge	1	
	7002449	Seal Kit - 7002448 Cartridge	1	
3	7002450	Coil	1	
4	7002451	Cartridge Without Coil	1	
	7011118	Seal Kit - 7002451 Cartridge	1	

	7000448	O-Ring (Between Sections)	2	
		WORKING SECTIONS (STANDARD PARTS)	Ref.	
101	7004859	Solenoid Assembly	2	
102	7003825	Washer	1	
103	7002348	Spring	1	
104	7002305	Guide Tube Assembly	1	
105	7002345	Cone, Female	1	
	Kit	O-Ring	1	
	Kit	O-Ring	1	
106	7002346	Pin, Push	1	
107	7002344	Plunger	1	
108	7000470	Tube, Guide	1	
109	7002341	Pin Actuator	1	
	Kit	Ring, Quad	1	
110	7002340	Guide, External Push Pin	1	
	Kit	O-Ring	1	
111	7002333	Sleeve, Inner Flux	1	
112	7002334	Spring	1	
113	7002336	Sleeve, Outer Flux	1	
114	7000418	Coil	1	
115	7002335	Case, Solenoid	1	
116	7002338	Plate, End	1	
	7002327	Nameplate	1	
117	7002339	Screw	4	

	7000414	Seal Kit - Working Section (1 Per Section)	2	
		WORKING SECTIONS - COMPLETE (INCLUDES ITEMS 101-117 AND RELIEF VALVE ASSEMBLY WHEN EQUIPPED)	Ref.	
151	7002315	Section #1 - Steer	1	
152		Section #2 Options:	1	
	7002316	Level Section (4640941 Valve) (Prior to S/N 27357)		
	7011183	Level Section (4640941 Valve) (S/N 27357 to Present)		
153	7002315	Section #3 - Tele	1	

SECTION 2 TURNTABLE

SECTION 2 TURNTABLE

FIGURE 2-7. CONTROL VALVE ASSEMBLY - BANG-BANG WITH DUMP SECTION (JUNE 1995 TO PRESENT) (CONTINUED)

FIG & ITEM #	PART NUMBER	DESCRIPTION	QTY.	REV.
154	Not Required	Section #4 Options:	0	
155		Relief Valve Options:	A/R	
	7000468	Crossover Relief Valve Assembly (Due to various suppliers, internal components are no longer field serviceable)		
	7002262	Dual Pilot Check Valve Assembly (Due to various suppliers, internal components are no longer field serviceable) (Prior to S/N 27357)		
	7011183	Dual Pilot Check Valve Assembly (Due to various suppliers, internal components are no longer field serviceable) (S/N 27357 to Present)		

SECTION 2 TURNTABLE

FIGURE 2-7. CONTROL VALVE ASSEMBLY - BANG-BANG WITH DUMP SECTION (JUNE 1995 TO PRESENT) (CONTINUED)

FIG & ITEM #	PART NUMBER	DESCRIPTION	QTY.	REV.

SECTION 2 TURNTABLE

FIGURE 2-8. ACCESSORY VALVE ASSEMBLY (MILLER) (MACHINES BUILT THROUGH 1989)

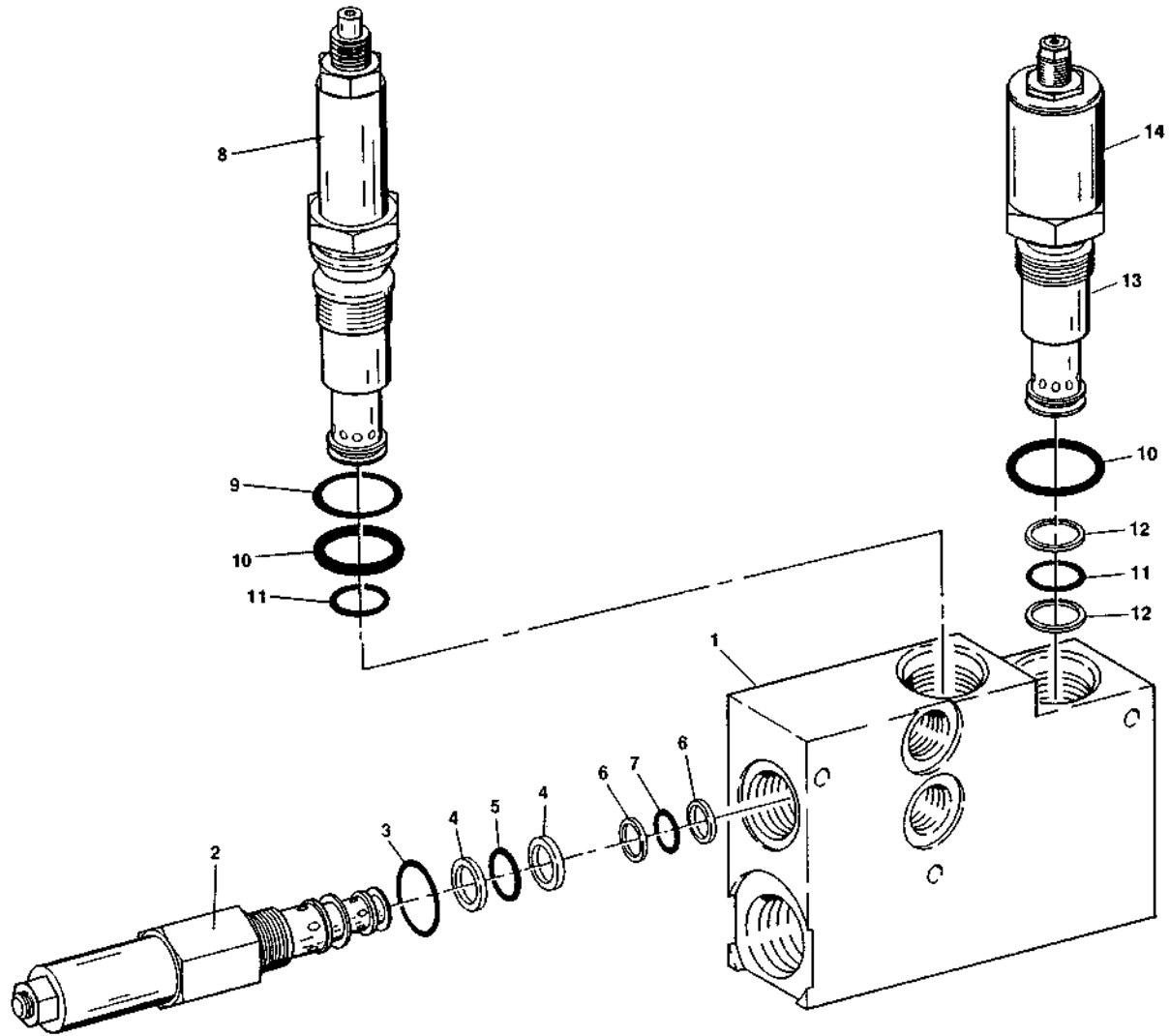

SECTION 2 TURNTABLE

FIGURE 2-8. ACCESSORY VALVE ASSEMBLY (MILLER) (MACHINES BUILT THROUGH 1989)

FIG & ITEM #	PART NUMBER	DESCRIPTION	QTY.	REV.
	4640535	ACCESSORY VALVE ASSEMBLY Note: Not sold as a complete assembly.	Ref.	A
1		Body (Not Sold Separately)	1	
2	7009755	Cartridge, Pressure Reducing/Relieving	1	
3	7009759	O-Ring	1	
4	7007760	Ring, Back-Up	2	
5	3790015	O-Ring	1	
6	7009761	Ring, Back-Up	2	
7	3790014	O-Ring	1	
8	7009756	Cartridge, Sequence	1	
9	3790118	O-Ring	1	
10	3790211	O-Ring	2	
11	3790016	O-Ring	2	
12	7009762	Ring, Back-Up	2	
13	7009757	Cartridge, 2-Position	1	
14	7009758	Coil (Includes Nut and Washer)	1	

SECTION 2 TURNTABLE

FIGURE 2-9. ACCESSORY VALVE ASSEMBLY (MACHINES BUILT 1990 TO PRESENT)

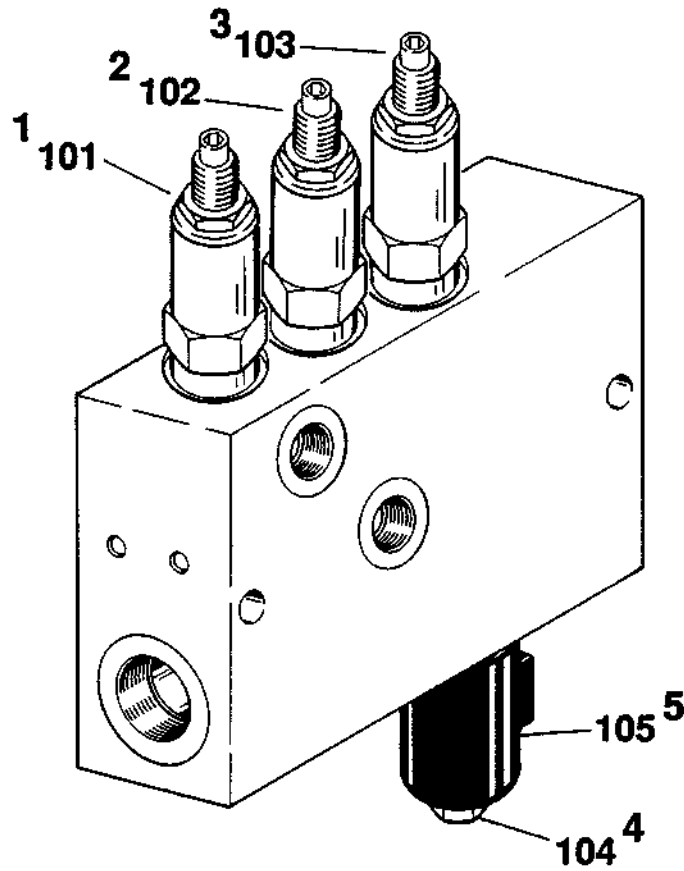

SECTION 2 TURNTABLE

FIGURE 2-9. ACCESSORY VALVE ASSEMBLY (MACHINES BUILT 1990 TO PRESENT)

FIG & ITEM #	PART NUMBER	DESCRIPTION	QTY.	REV.
	4640580	ACCESSORY VALVE ASSEMBLY (MACHINES BUILT 1990 TO SEPTEMBER 1991) Note: <u>Not</u> sold as a complete assembly.	Ref.	—
1	7004365	Cartridge - Sequence	1	
2	7004366	Cartridge - Pressure Reducing	1	
3	7004367	Cartridge - Main Relief	1	
4	7004369	Cartridge Less Coil - Dump	1	
5	7004368	Coil	1	
	2900707	Seal Kit (Sequence and Pressure Reducing)	2	
	2900708	Seal Kit (Main Relief)	1	
	2900709	Seal Kit (Dump)	1	
	4640716	ACCESSORY VALVE ASSEMBLY (MACHINES BUILT SEPTEMBER 1991 TO PRESENT) Note: Refer to P/N stamped on cartridge hex nut for identification.	Ref.	—
101	7012506	Cartridge - Sequence (Hydraforce PS10-34A)	1	
	7010552	Cartridge - Sequence (Vickers/Modular Controls PSV7-10V)	1	
102	7012505	Cartridge - Pressure Reducing (Hydraforce PR10-32A)	1	
	7010553	Cartridge - Pressure Reducing (Vickers/Modular Controls PRV1-10V)	1	
103	7012507	Cartridge - Main Relief (Hydraforce RV50-26A)	1	
	7010554	Cartridge - Main Relief (Vickers/Modular Controls RV5-10V)	1	
104	7004369	Cartridge Less Coil - Dump (Hydraforce SV16-21)	1	
105	7004368	Coil (Hydraforce 6352012)	1	
104	7010556	Cartridge w/Coil - Dump (Vickers/Modular Controls SV3-16V)	1	
105	7010555	Coil (Vickers/Modular Controls 565966)	1	
	7012509	Seal Kit (Sequence) (Hydraforce Version)	1	
	7010557	Seal Kit (Sequence) (Vickers/Modular Controls Version)	1	
	7012510	Seal Kit (Pressure Reducing) (Hydraforce Version)	1	
	7010558	Seal Kit (Pressure Reducing) (Vickers/Modular Controls Version)	1	
	7012511	Seal Kit (Main Relief) (Hydraforce Version)	1	
	7010559	Seal Kit (Main Relief) (Vickers/Modular Controls Version)	1	
	2900709	Seal Kit (Dump) (Hydraforce Version)	1	
	7010560	Seal Kit (Dump) (Vickers/Modular Controls Version)	1	

SECTION 2 TURNTABLE

FIGURE 2-10. CONTROL VALVE ASSEMBLY - 1 SECTION BANG-BANG (100HX+10/110HXER MACHINES)

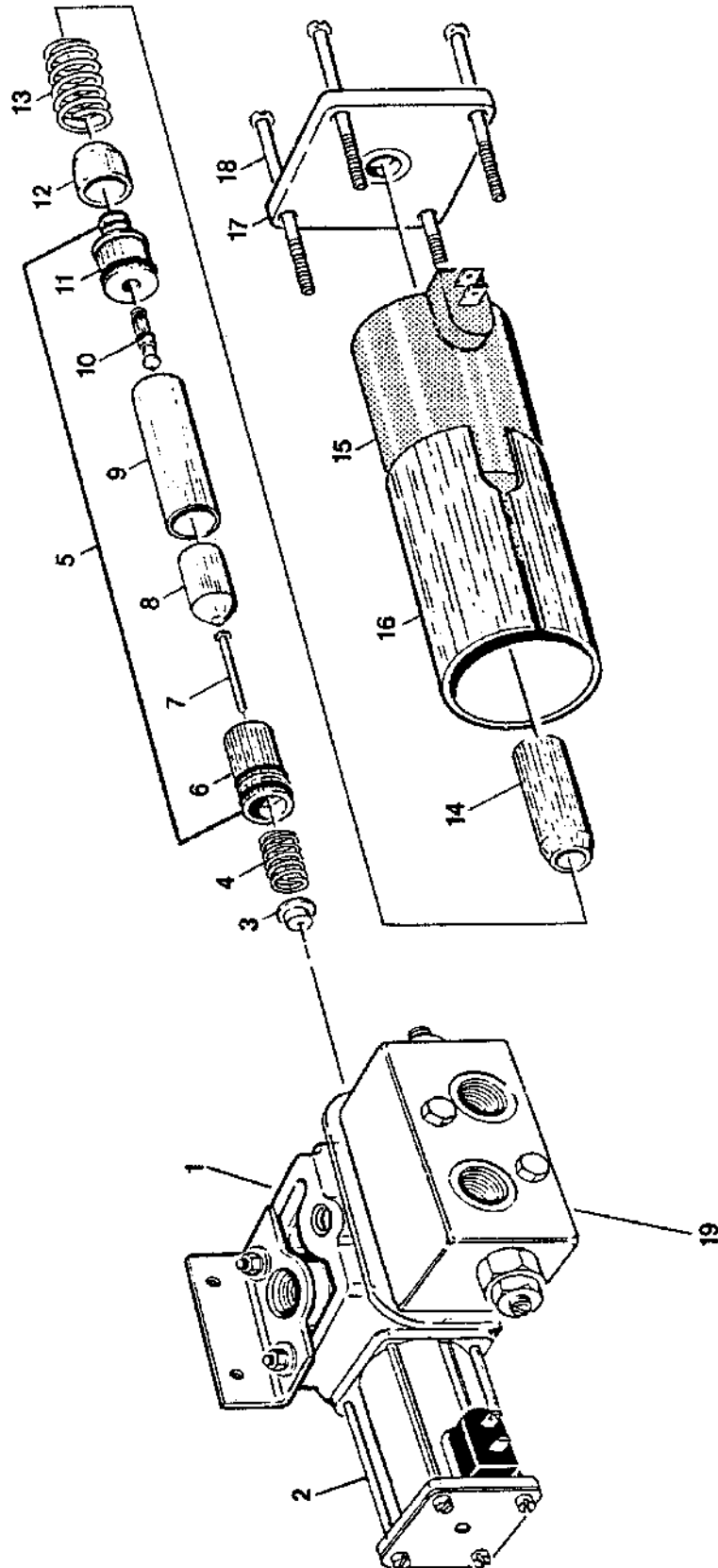

SECTION 2 TURNTABLE

FIGURE 2-10. CONTROL VALVE ASSEMBLY - 1 SECTION BANG-BANG (100HX+10/110HXER MACHINES)

FIG & ITEM #	PART NUMBER	DESCRIPTION	QTY.	REV.
1	7002315	Telescope Section - Complete	1	
2	7004859	Solenoid Assembly	2	
3	7002274	Washer	1	
4	7002348	Spring	1	
5	7002305	Guide Tube Assembly	1	
6	7002345	Cone, Female	1	
	Kit	O-Ring	1	
	Kit	O-Ring	1	
7	7002346	Pin, Push	1	
8	7002344	Plunger	1	
9	7000470	Tube, Guide	1	
10	7002341	Pin, Actuator	1	
	Kit	Ring, Quad	1	
11	7002340	Tuide, External Push Pin	1	
	Kit	O-Ring	1	
12	7002333	Sleeve, Inner Flux	1	
13	7002334	Spring	1	
14	7002336	Sleeve, Outer Flux	1	
15	7000418	Coil	1	
16	7002335	Case, Solenoid	1	
17	7002338	Plate, End	1	
	7002327	Nameplate	1	
18	7002339	Screw	4	
19	7000468	Crossover Relief Valve Assembly (Due to various suppliers, internal components are no longer field serviceable)	1	
	7000414	----- Seal Kit - Working Section	1	

SECTION 2 TURNTABLE

FIGURE 2-11. SWING DRIVE, BEARING AND LOCK INSTALLATIONS

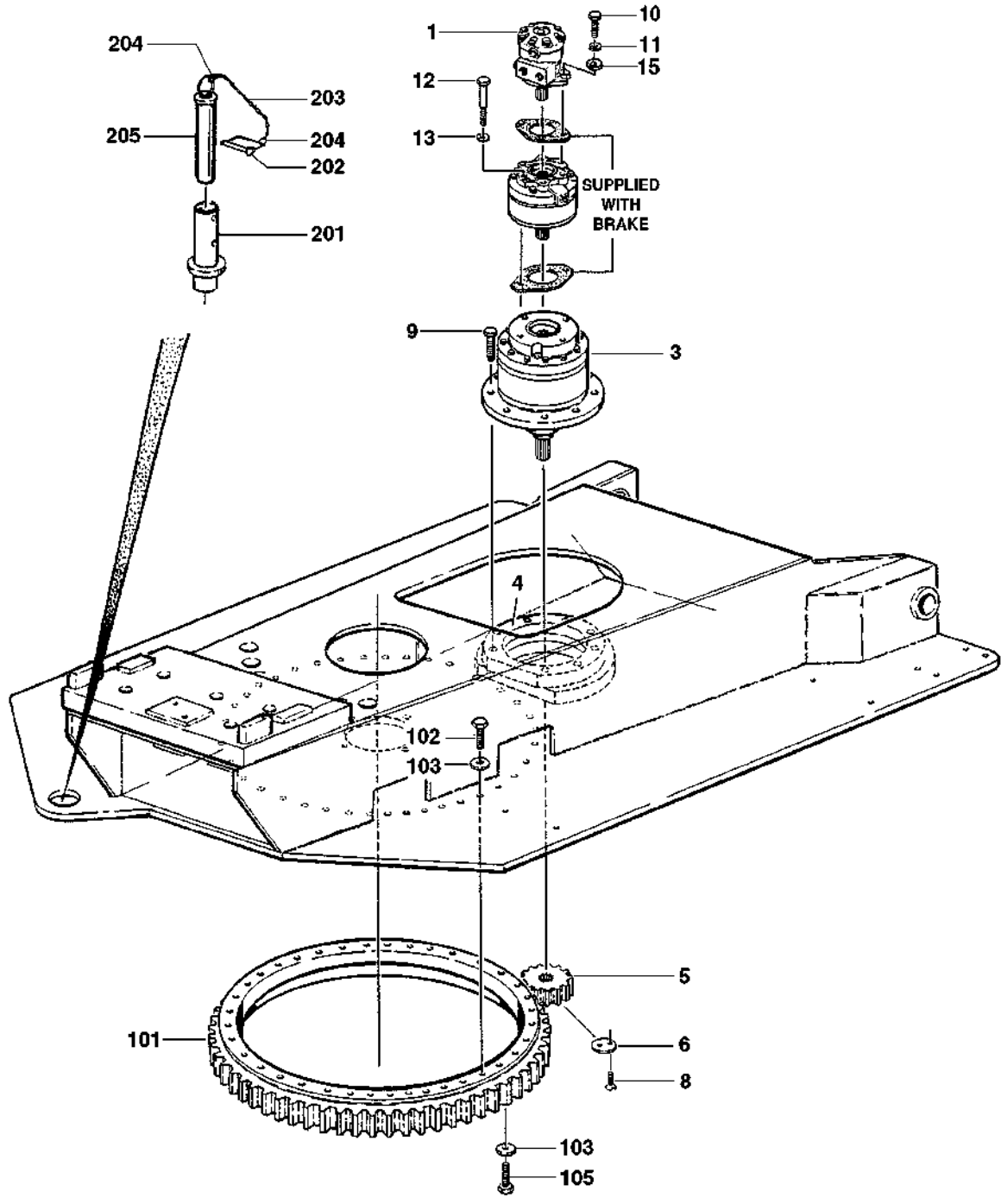

SECTION 2 TURNTABLE

FIGURE 2-11. SWING DRIVE, BEARING AND LOCK INSTALLATIONS

FIG & ITEM #	PART NUMBER	DESCRIPTION	QTY.	REV.
	0239786	SWING DRIVE INSTALLATION	Ref.	6/E
1	3160127	Swing Motor Assembly (See Figure 2-12 for Breakdown)	1	
2		Swing Brake Options:	1	
	0920032	Brake - Prior to April 1992 (See Figure 2-13 for Breakdown)		
	0920083	Brake - April 1992 to S/N 33476 (See Figure 2-14 for Breakdown)		
	0920109	Brake - S/N 33476 to Present (See Figure 2-14 for Breakdown)		
3	2780116	Swing Hub Assembly (See Figure 2-15 for Breakdown)	1	
4		Mounting Plate Options:	1	
	4843302	Prior to June 1992		
	4844109	June 1992 to Present		
5	2440058	Gear, Pinion	1	
6	3533337	Plate, Retaining	1	
7	0100019	Loctite #271 (Not Shown)	A/R	
8	3900164	Screw, Countersunk 1/2"-20NF x 1"	2	
9	0642216	Bolt 3/4"-10NC x 1 1/4"	8	
10	0641810	Bolt 1/2"-13NC x 1 1/4"	2	
11	4761800	Lockwasher 1/2"	2	
12	3931864	Bolt, Socket 1/2"-13NC x 4" (Grade 8)	2	
13	4740189	Washer, Special	2	
14	0100009	Sealant, RTV #738 (Not Shown)	A/R	
15	4740171	Washer, Hardened	A/R	
	0250348	TURNTABLE BEARING INSTALLATION	Ref.	7
101	0440193	Bearing, Turntable	1	
102	0682016	Bolt 5/8"-11NC x 2" (Grade 8)	40	
	0682026	Bolt 5/8" -11NC x 3 1/4" (Grade 8)	40	
103	4740004	Washer, Special	80	
104	0100019	Loctite #271 (Not Shown)	A/R	
105		Bolt Options:	40	
	0682016	Bolt 5/8"-11NC x 2" (Grade 8)		
	0682018	Bolt 5/8"-11NC x 2 1/4" (Grade 8)(Use with item 106)		
106	0100004	Devcon (Required Prior to December 1992) (Not Shown)	A/R	
	0239842	TURNTABLE LOCK INSTALLATION	Ref.	2
201	4843318	Bushing Weldment	1	
202	3421565	Pin, Snap	1	
203	1260017	Chain	9in/23cm	
204	3760170	Ring, Quick Release	2	
205	3421563	Pin, Locking	1	

SECTION 2 TURNTABLE

FIGURE 2-12. SWING MOTOR ASSEMBLY - NICHOLS

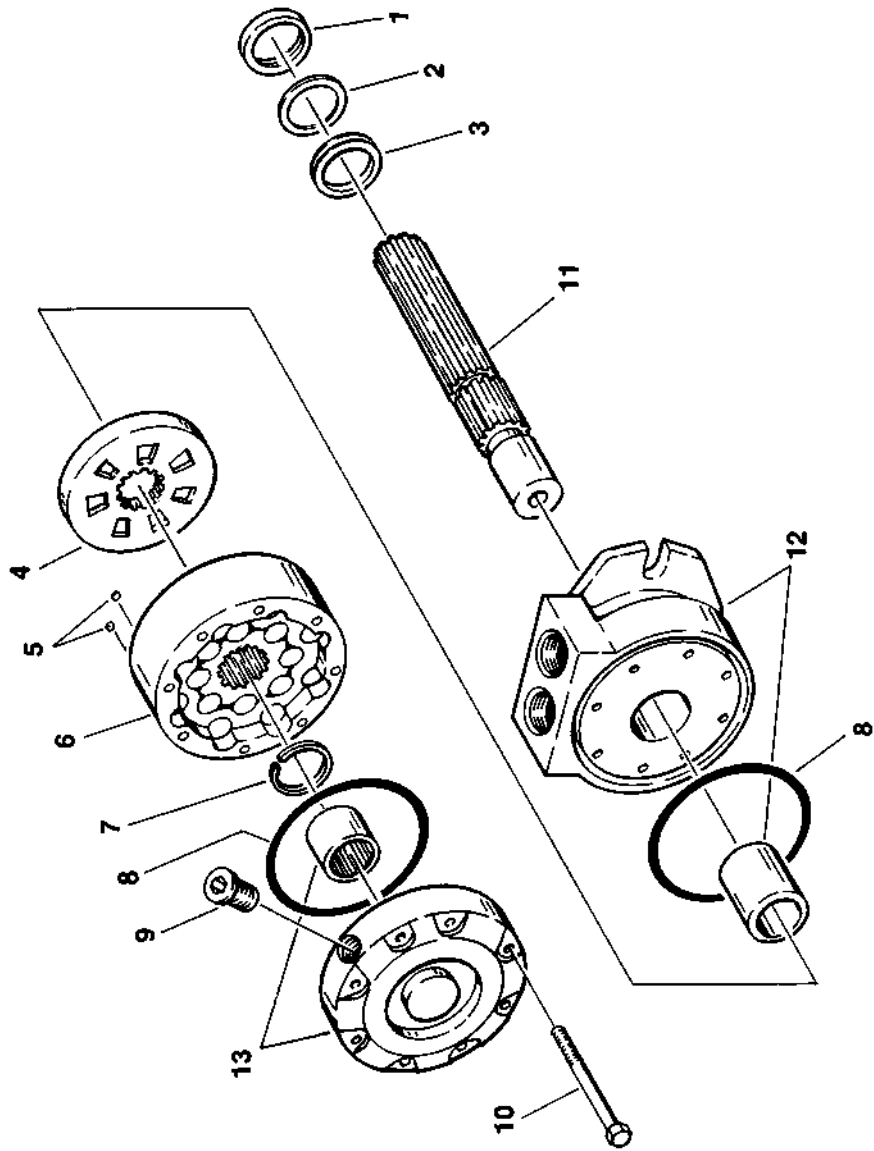

SECTION 2 TURNTABLE

FIGURE 2-12. SWING MOTOR ASSEMBLY - NICHOLS

FIG & ITEM #	PART NUMBER	DESCRIPTION	QTY.	REV.
	3160127	SWING MOTOR ASSEMBLY		D
1	Kit	Seal Dust	1	
2	Kit	Ring, Back-up	1	
3	Kit	Seal, Quad Ring	1	
4	7004196	Valve, Rotary	1	
5	7004167	Ball, Check Valve	2	
6		IGR Assembly Options:	1	
	7004179	Prior to S/N 38344		
	7010791	S/N 38344 to Present		
7	7004191	Ring, Retaining	1	
8	Kit	Seal, Ring	2	
9	7004171	Plug, Vent (Includes O-Ring)	1	
10		Bolt Options:	8	
	7004197	Prior to S/N 38344		
	7010792	S/N 38344 to Present		
11		Shaft, Spline Options:	1	
	7010700	Prior to S/N 46431		
	7010793	S/N 46431 to Present		
12		Body/Bearing Assembly Options:	1	
	7004198	Prior to S/N 38344		
	7010794	S/N 38344 to Present		
13	7004192	Cover/Bearing Assembly	1	
	7004177	Seal Kit (Includes of items 1, 2, 3, 8, and O-Ring on #9) (Prior to S/N 38344)	1	
	7010790	Seal Kit (Includes of items 1, 2, 3, 8, and O-Ring on #9) (S/N 38344 to Present)	1	

SECTION 2 TURNTABLE

FIGURE 2-13. SWING BRAKE ASSEMBLY (PRIOR TO APRIL 1992)

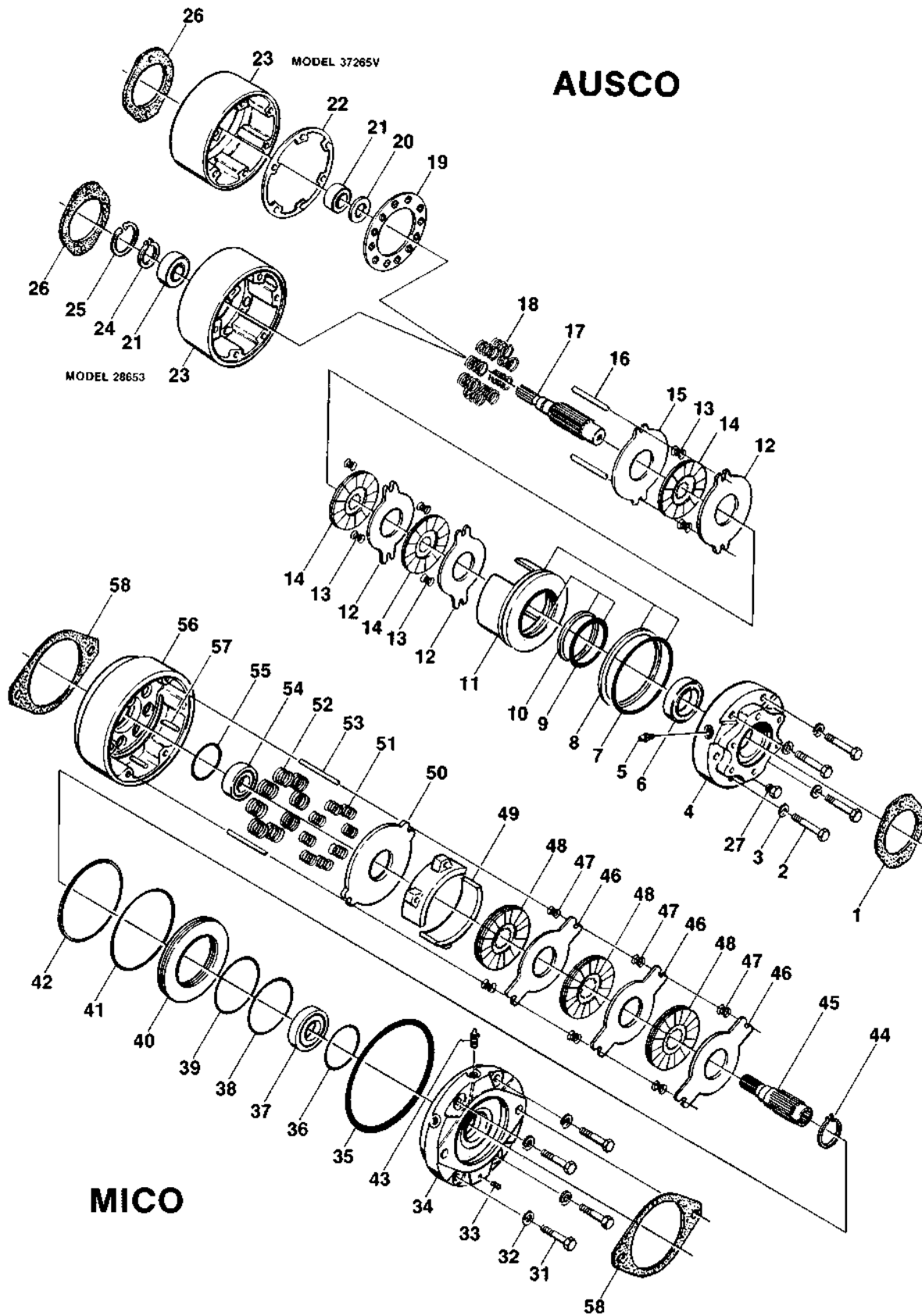

SECTION 2 TURNTABLE

FIGURE 2-13. SWING BRAKE ASSEMBLY (PRIOR TO APRIL 1992)

FIG & ITEM #	PART NUMBER	DESCRIPTION	QTY.	REV.
	0920032	SWING BRAKE ASSEMBLY - AUSCO (MODEL 28653)	Ref.	—
	0920032	SWING BRAKE ASSEMBLY - AUSCO (MODEL 37265V)	Ref.	C
		Note: Refer to Model Number stamped on the front of the Housing item 23		
1	Kit	Gasket	1	
2	7000730	Bolt (Model 38653)	4	
	7003007	Bolt, Flanged (Model 37265V)	4	
3	7000729	Lockwasher (Model 28653 Only)	4	
4	7003012	Plate, Power (Model 38653)	1	
	7003091	Plate, Power (Model 37265V)	1	
5	7000796	Bleeder	1	
6	7000760	Bearing, Ball (Model 37265V Only)	1	
7	Kit	O-Ring	1	
8	Kit	Ring, Back-up	1	
9	Kit	O-Ring	1	
10	Kit	Ring, Back-up	1	
11	7000721	Piston (Model 28653)	1	
	7003057	Piston (Model 37265V)	1	
12	7000720	Disc, Stationary (Model 28653)	3	
	7003056	Disc, Stationary (Model 37265V)	3	
13	7003006	Spring, Compression	6	
14	7000732	Disc, Rotating (Model 28653)	3	
	7003055	Disc, Rotating (Model 37265V)	3	
15	7000718	Disc, Primary (Model 28653)	1	
	7003054	Disc, Primary (Model 37265V)	1	
16	7000717	Pin, Torque	2	
17	7003013	Shaft, Splined (Model 28653)	1	
	7003053	Shaft, Splined (Model 37265V)	1	
18	7000798	Spring, Compression (Model 28653)	8	
	7003052	Spring, Compression (Model 37265V)	8	
19	7003051	Retainer, Spring (Model 37265V Only)	1	
20	Kit	Seal, Oil	1	
21	7000713	Bearing, Ball (Model 28653)	1	
	7003049	Bearing, Ball (Model 37265V)	1	
22	Kit	Gasket (Model 37265V Only)	1	
23	7000714	Housing (Model 28653)	1	
	7003090	Housing (Model 37265V)	1	
24	7000712	Ring, Retaining (Model 28653 Only)	1	
25	7000711	Ring, Retaining (Model 28653 Only)	1	
26	Kit	Gasket	1	
27	7003059	Valve, Pressure Relief (Model 37265V Only)	1	
28	Not Used			
29	Not Used			
30	Not Used			
	2900131	Seal Kit (Includes Items 1,7,8,9,10,20,22 and 26)		

SECTION 2 TURNTABLE

SECTION 2 TURNTABLE

FIGURE 2-13. SWING BRAKE ASSEMBLY (PRIOR TO APRIL 1992) (CONTINUED)

FIG & ITEM #	PART NUMBER	DESCRIPTION	QTY.	REV.
	0920032	SWING BRAKE ASSEMBLY - MICO	Ref.	B
31	7007913	Capscrew	4	
32	7007912	Lockwasher	4	
33	7007924	Plug	1	
34	7007928	Cover	1	
35	Kit	Ring, Square	1	
36	Kit	O-Ring	1	
37	Kit	Bearing	1	
38	Kit	O-Ring	1	
39	Kit	Ring, Back-Up	1	
40	7007923	Piston	1	
41	Kit	O-Ring	1	
42	Kit	Ring, Back-Up	1	
43	7007914	Bleeder	1	
44	Kit	Ring, Retaining	1	
45	7007926	Shaft	1	
46	7007908	Disc	3	
47	7007916	Spring	6	
48	7007909	Disc, Friction	3	
49	7007902	Separator	2	
50	7007907	Disc	1	
51	7007906	Spring	8	
52	7007905	Spring	8	
53	7007915	Pin, Dowel	2	
54	Kit	Bearing	1	
55	Kit	O-Ring	1	
56	7007930	Housing	1	
57	7007901	Pin, Spiral	4	
58	7007933	Gasket	1	
	7007934	Gasket	1	
	2900642	Seal Kit (Includes Items 35,36,38,39,41,42,55 and 58 Gaskets)	1	
	7007927	Bearing Kit (Includes Items 36,37,44,54,55 and 58 Gasket)	1	

SECTION 2 TURNTABLE

FIGURE 2-13. SWING BRAKE ASSEMBLY (PRIOR TO APRIL 1992) (CONTINUED)

FIG & ITEM #	PART NUMBER	DESCRIPTION	QTY.	REV.

SECTION 2 TURNTABLE

FIGURE 2-14. SWING BRAKE ASSEMBLY (APRIL 1992 to PRESENT)

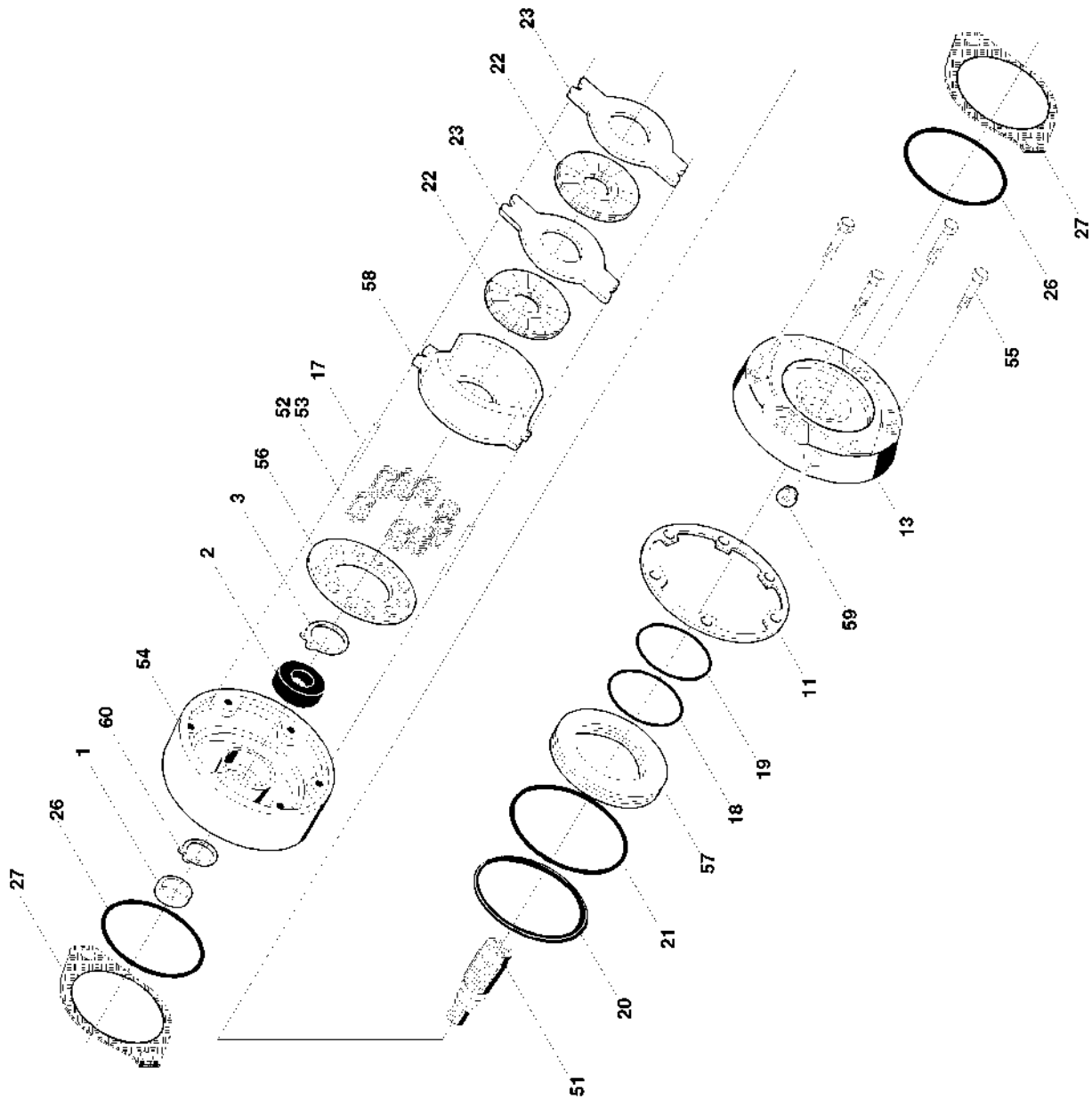

SECTION 2 TURNTABLE

FIGURE 2-14. SWING BRAKE ASSEMBLY (APRIL 1992 TO PRESENT)

FIG & ITEM #	PART NUMBER	DESCRIPTION	QTY.	REV.
		SWING BRAKE ASSEMBLIES (STANDARD PARTS)	Ref.	
1	Kit	Seal, Oil	1	
2	Kit	Bearing	1	
3	7007977	Ring, Retaining	1	
4 to 10	Not Used			
11	Kit	Seal, Case	1	
12	Not Used			
13	7011719	Cover	1	
14	Not Used			
15	Not Used			
16	Not Used			
17	7007987	Pin, Dowel	2	
18	Kit	Ring, Back-up (Inner)	1	
19	Kit	O-Ring (Inner)	1	
20	Kit	Ring, Back-up (Outer)	2	
21	Kit	O-Ring (Outer)	2	
22	Kit	Rotor		
23	Kit	Stator		
24	Not Used			
25	Not Used			
26	Kit	O-Ring	2	
27	7007934	Gasket	2	
	2900766	Seal Kit (Includes Items 1,11,16,17,18,19,26 and 27)	1	
	2900768	Bearing Kit (Includes Items 1,2,11,26 and 27)	1	
		SWING BRAKE ASSEMBLY (VARIABLE PARTS)		
	0920083	Machines Built Through 1992	Ref.	—
	0920083	Machines Built 1993 to S/N 33476	Ref.	A
	0920109	Machines Built S/N 33476 to Present	Ref.	B
51		Shaft Options:	1	
	7011718	Machines Built Through 1992		
	7011720	Machines Built Through 1993 to Present		
52		Spring Options:	A/R	
		0920083 Brake Components:		
	7007979	Spring (Small)	6	
	7007980	Spring (Large)	6	
	Not Required	0920109 Brake	0	
53		Spring Options:	A/R	
	Not Required	0920083 Brake	0	
		0920109 Brake Components:		
	7007970	Spring (Red)	6	
	7018602	Spring (Blue)	3	
54		Housing Options:	1	
	7007981	Machines Built Through 1992		
	7011713	Machines Built Through 1993 to S/N 33476		
	7018605	Machines Built S/N 33476 to Present		

SECTION 2 TURNTABLE

SECTION 2 TURNTABLE

FIGURE 2-14. SWING BRAKE ASSEMBLY (APRIL 1992 TO PRESENT) (CONTINUED)

FIG & ITEM #	PART NUMBER	DESCRIPTION	QTY.	REV.
55		Bolt, Washer Head	4	
	7007985	0920083 Brake		
	7018607	0920109 Brake		
56		Guide, Spring	1	
	Not Required	Machines Built Through 1992		
	7011717	Machines Built Through 1993 to S/N 33476		
	7018606	Machines Built S/N 33476 to Present		
57		Piston	1	
	7007923	0920083 Brake		
	7018603	0920109 Brake		
58		Return Plate/Separator Assembly Options:	A/R	
		0920083 Brake Components:		
	Kit	Plate, Return		
	7011715	Separator Assembly		
	7011714	Pin		
	7007983	Separator		
	7018604	0920109 Brake (1 Welded Component)		
59		Screw, Bleeder/Plug Options:	1	
	7007914	0920083 Brake (Screw, Bleeder)		
	7018609	0920109 Brake (Plug)		
60		Ring, Retaining Options:	A/R	
	Not Required	Machines Built Through 1992		
	7011716	Machines Built Through 1993 to Present		
		----- Lining Kit Options (Includes Items 11,20,21,26, 27 & 58):		
	2900767	0920083 Brake	1	
	7018608	0920109 Brake		

SECTION 2 TURNTABLE

FIGURE 2-14. SWING BRAKE ASSEMBLY (APRIL 1992 TO PRESENT) (CONTINUED)

FIG & ITEM #	PART NUMBER	DESCRIPTION	QTY.	REV.

SECTION 2 TURNTABLE

FIGURE 2-15. SWING HUB ASSEMBLY

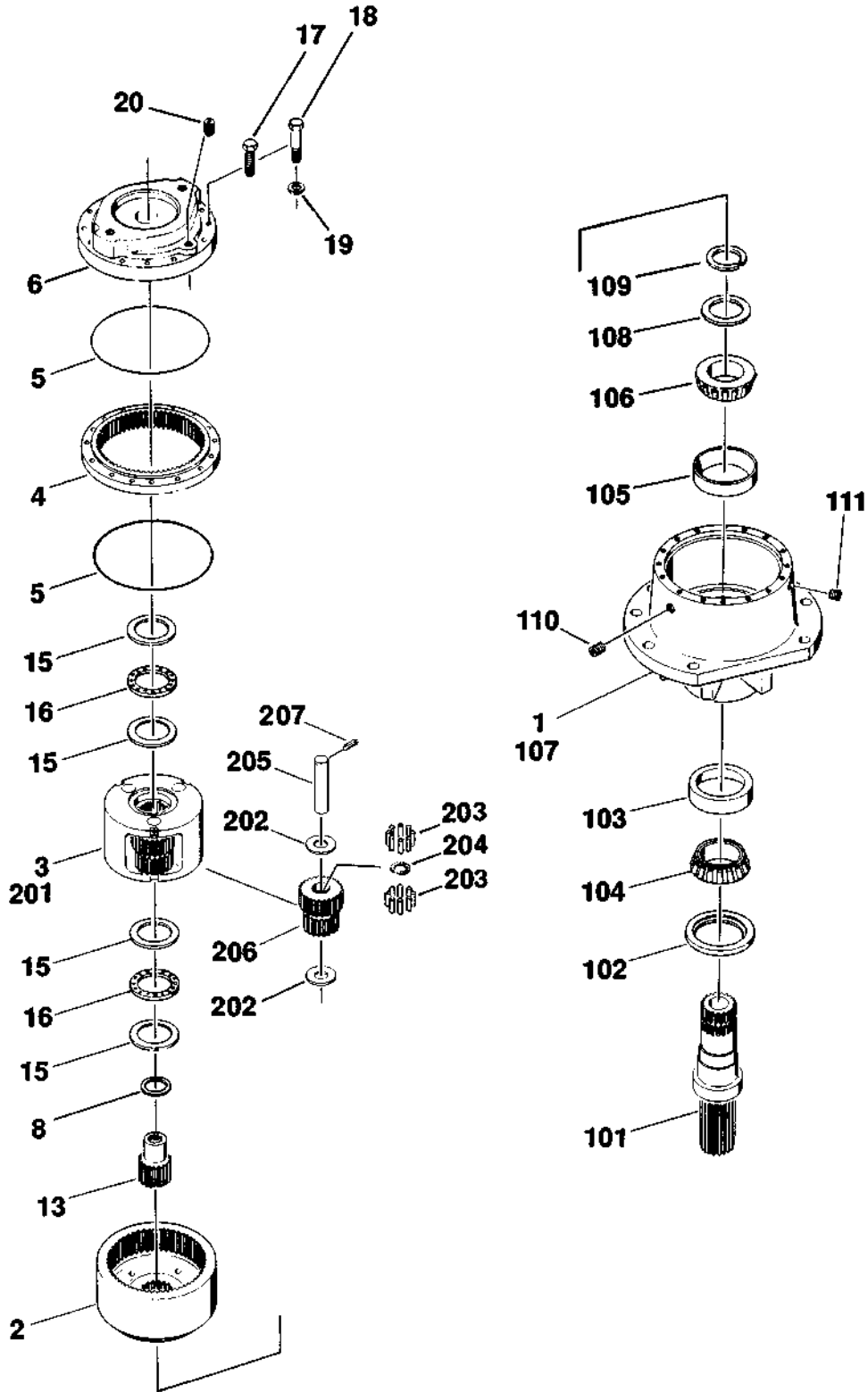

SECTION 2 TURNTABLE

FIGURE 2-15. SWING HUB ASSEMBLY

FIG & ITEM #	PART NUMBER	DESCRIPTION	QTY.	REV.
	2780116	SWING HUB ASSEMBLY	Ref.	—
1	7001916	Hub and Spindle Assembly (See Items 101-111 for Breakdown)	1	
2	7001917	Gear, Internal	1	
3	7001918	Carrier Assembly (See items 201-207 for Breakdown)	1	
4	7000279	Gear, Ring	1	
5	Kit	O-Ring	2	
6	7001920	Cover	1	
7	Not Used			
8	7001922	Washer, Thrust	1	
9 to 12	Not Used			
13	7001921	Gear, Input	1	
14	Not Used			
15	7000287	Washer, Thrust	4	
16	7000288	Bearing, Thrust	2	
17	7001923	Bolt	8	
18	7001924	Bolt, Shoulder	4	
19	7001929	Lockwasher	4	
20	7001926	Plug, Pipe	1	
	7001916	HUB AND SPINDLE ASSEMBLY	Ref.	
101	7001982	Shaft, Output	1	
102	Kit	Seal, Lip	1	
103	7000272	Cup, Bearing	1	
104	7000273	Cone, Bearing	1	
105	7000274	Cup, Bearing	1	
106	7000275	Cone, Bearing	1	
107	Not Available	Hub	1	
108	Kit	Spacer	1	
109	Kit	Ring, Retaining	1	
110	7001928	Plug, Pipe	1	
111	7001926	Plug, Pipe	2	
	7001918	CARRIER ASSEMBLY	Ref.	
201	Not Available	Housing, Carrier	1	
202	Kit	Washer, Thrust	6	
203	7001902	Bearing, Needle	84	
204	Kit	Spacer	3	
205	7001904	Shaft, Planet	3	
206	Kit	Gear, Cluster	3	
207	Kit	Rollpin	3	
	2900202	Seal Kit (Includes Items 5, 102, 108 and 109)	1	
	7001927	Cluster Gear Kit (Includes Items 202, 204,206 and 207)	1	

SECTION 2 TURNTABLE

FIGURE 2-16. ROTARY COUPLING AND COLLECTOR RING ASSEMBLY AND INSTALLATION

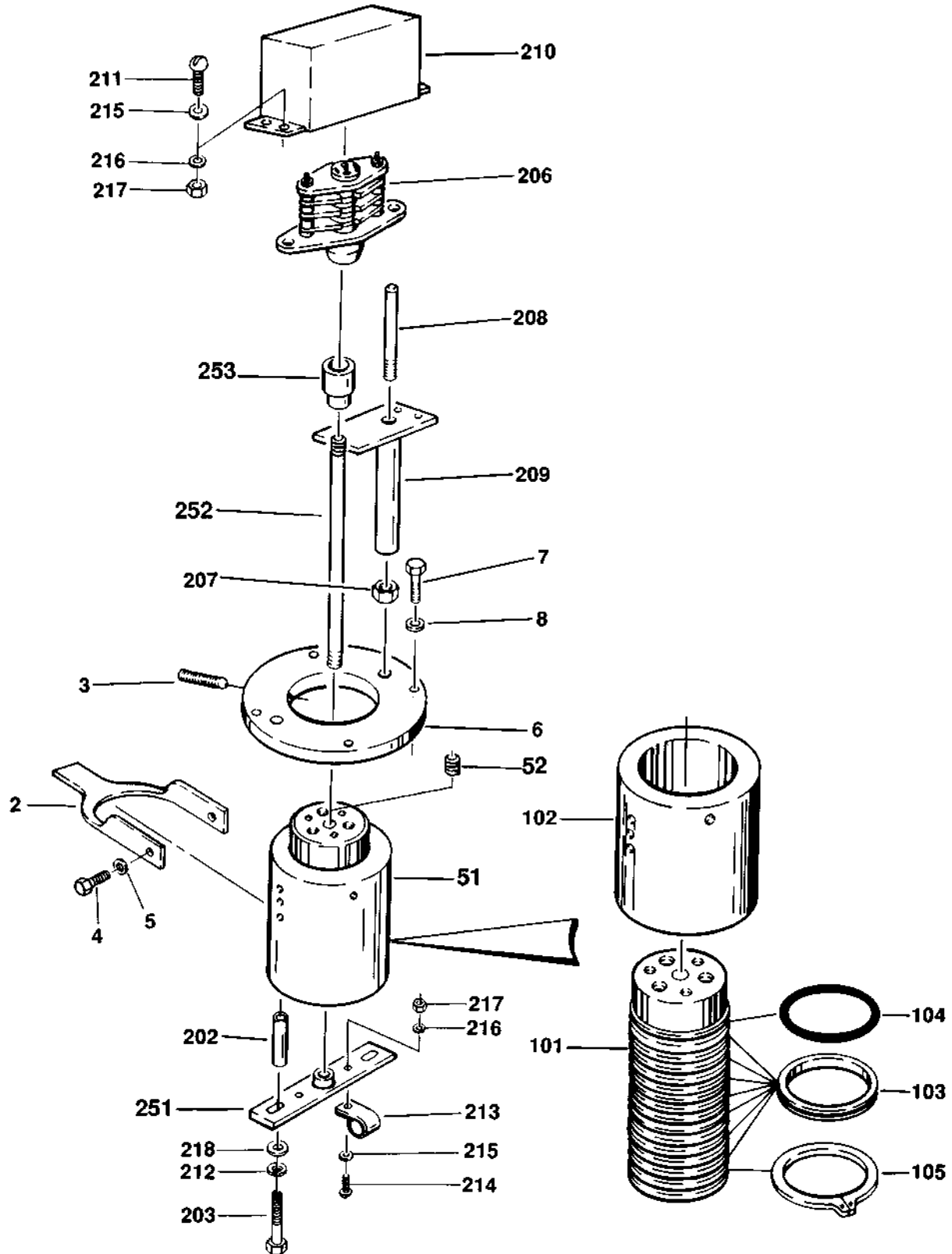

SECTION 2 TURNTABLE

FIGURE 2-16. ROTARY COUPLING AND COLLECTOR RING ASSEMBLY AND INSTALLATION

FIG & ITEM #	PART NUMBER	DESCRIPTION	QTY.	REV.
		ROTARY OIL COUPLING INSTALLATION (STANDARD PARTS)	Ref.	
1	Not Used			
2	3530403	Plate, Retaining	1	
3	3951820	Setscrew 1/2"-13NC x 2 1/2"	2	
4	0641807	Bolt 1/2"-13NC x 7/8"	2	
5	4761800	Lockwasher 1/2"	2	
6	1440154	Collar	1	
7	0641514	Bolt 5/16"-18NC x 1 3/4"	4	
8	4761500	Lockwasher 5/16"	4	
9	0100011	Loctite #242 (Not Shown)	A/R	
10	0100019	Loctite #271 (Not Shown)	A/R	
		ROTARY OIL COUPLING INSTALLATION (VARIABLE PARTS)		
	0238032	Prior To April 1991	Ref.	—
	0251852	April 1991 To September 1994	Ref.	A
	0254882	September 1994 To Present	Ref.	3
51		Rotary Oil Coupling Assembly (6 Port) (See Items 101-105 for Breakdown)	1	
	1660160	Prior to September 1994		
	1660213	September 1994 to Present		
52	2200222	Plug, Pipe Option:	A/R	
	2200222	Prior to September 1994	1	
	Not Required	September 1994 to Present	0	
	Not Required	With Collector Ring	0	
		ROTARY OIL COUPLING ASSEMBLIES	Ref.	
101		Swivel Body Options:	1	
	0620058	Body for 1660160 Coupling		
	Not Available	Body for 1660213 Coupling		
102		Swivel Housing Options:	1	
	2760091	Housing for 1660160 Coupling		
	Not Available	Housing for 1660213 Coupling		
103	Kit	T-Seal	7	
104	3760004	Ring, Retaining (1660160 Coupling Only)	1	
105	Kit	O-Ring	1	

		Seal Kit Options:	1	
	2901146	1660154, 1660160 & 1660185 Couplings (Includes Items 103 & 105)		
	Use 1660213EX	1660213 Couplings (was p/n 7013175)		
		Note: Due to complexity of repair, seal kit no longer available. Use rebuilt unit as replacement.		

SECTION 2 TURNTABLE

SECTION 2 TURNTABLE

FIGURE 2-16. ROTARY COUPLING AND COLLECTOR RING ASSEMBLY AND INSTALLATION (CONTINUED)

FIG & ITEM #	PART NUMBER	DESCRIPTION	QTY.	REV.
		OPTIONAL COLLECTOR RING INSTALLATION (STANDARD PARTS)	Ref.	
201	Not Used			
202	0960224	Bushing	2	
203	0641418	Bolt 1/4"-20NC x 2 1/4"	2	
204	Not Used		1	
205	Not Used			
206	Not Used			
207	3311801	Nut 1/2"-13NC	2	
208	3420290	Pin, Drive	2	
209	0231047	Guide, Drive	2	
210	Not Used			
211	0721005	Screw, Machine #10-24NC x 5/8"	4	
212	4761400	Lockwasher 1/4"	2	
213	1320040	Clamp, Cable	2	
214	3911012	Screw, Machine	1	
215	4751000	Flatwasher #10	6	
216	4761000	Lockwasher #10	5	
217	3311001	Nut #10-24NC	5	
218	4751400	Flatwasher 1/4"	2	
		COLLECTOR RING INSTALLATION - MACHINES WITH SINGLE OR NO AXLE JACK (VARIABLE PARTS)		
	0232123	Machines With Single Or No Axle Jack	Ref.	7
	0252284	Machines With Dual Axle Jacks	Ref.	3
251		Bracket Weldment Options:	1	
	0230470	Machines With Single Or No Axle Jack	1	
	4843822	Machines With Dual Axle Jacks	1	
252		Pipe Options:	1	
	3460065	Machines With Single Or No Axle Jack	1	
	2180763	Machines With Dual Axle Jacks	1	
253		Bushing Options:	1	
	0230435	Machines With Single Or No Axle Jack	1	
	0961531	Machines With Dual Axle Jacks	1	
254		Collector Ring Assembly Options:	1	
	3760036	Machines With Single Or No Axle Jack	1	
	3760108	Machines With Dual Axle Jacks	1	
255		Cover Options:	1	
	1670594	Machines With Single Or No Axle Jack	1	
	0234721	Machines With Dual Axle Jacks	1	

SECTION 2 TURNTABLE

FIGURE 2-16. ROTARY COUPLING AND COLLECTOR RING ASSEMBLY AND INSTALLATION
(CONTINUED)

FIG & ITEM #	PART NUMBER	DESCRIPTION	QTY.	REV.

SECTION 2 TURNTABLE

FIGURE 2-17. DEUTZ ENGINE INSTALLATION WITHOUT NOISE REDUCTION (BUILT PRIOR TO OCTOBER 1992)

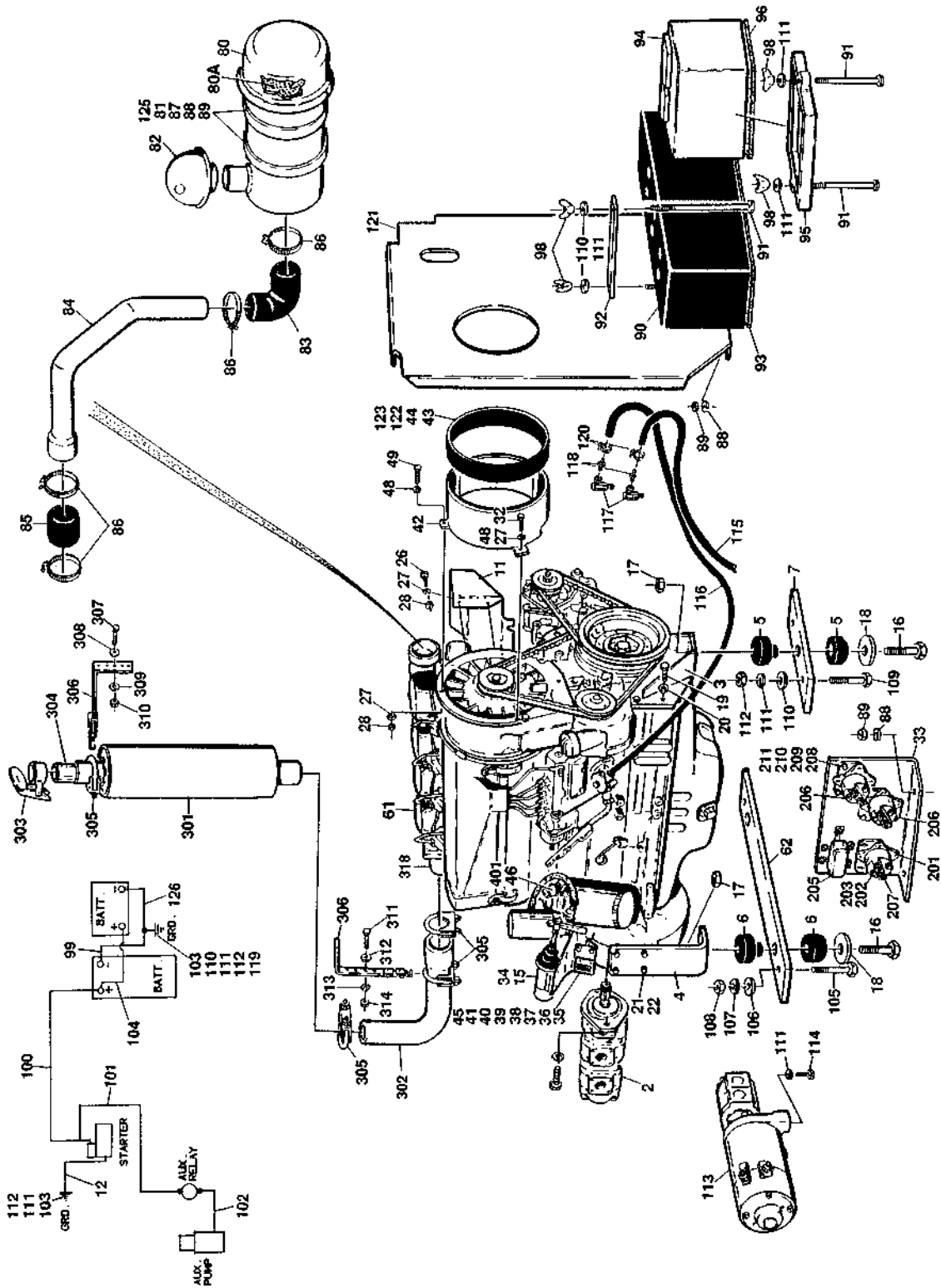

SECTION 2 TURNTABLE

FIGURE 2-17. DEUTZ ENGINE INSTALLATION WITHOUT NOISE REDUCTION (BUILT PRIOR TO OCTOBER 1992)

FIG & ITEM #	PART NUMBER	DESCRIPTION	QTY.	REV.
		DEUTZ ENGINE ASSEMBLY	Ref.	
	0239865	Standard Engine	Ref.	I
	0251167	Clean Burn Engine	Ref.	G
1	Not Used			
2	3600139	Pump Assembly (See Figure 2-22 for Breakdown)	1	
3	3200229	Support, Motor (Front)	1	
4	3200228	Support, Motor (Rear Side)	2	
5	3200133	Mount, Engine (Front)	1	
6	3200183	Mount, Engine (Rear)	2	
7	3200227	Bracket, Mounting (Front)	1	
8	Not Used			
9	Not Used			
10	Not Used			
11	4060610	Deflector (Prior to December 1990)	1	
12	1060044	Cable, Battery (Start Solenoid to Ground)	1	
13	Not Used			
14	Not Used			
15		Throttle Shut-Off Components (See Figure 2-19 for Breakdown)	A/R	
16	0642032	Bolt 5/8"-20NC x 4"	3	
17	3312005	Locknut 5/8"-20NC	3	
18	4740242	Flatwasher, Special	3	
19	0701427	Bolt, Metric 14mm x 100mm	4	
20	4740191	Lockwasher, Metric 14mm	4	
21	0701215	Bolt, Metric 12mm x 35mm	8	
22	4832100	Lockwasher, Metric 12mm	8	
23	Not Used			
24	Not Used			
25	Not Used			
26	0641406	Bolt 1/4"-20NC x 3/4"	4	
27	4761400	Lockwasher 1/4"	3	
28	3311401	Nut 1/4"-20NC	4	
29	Not Used			
30	Not Used			
31	4420001	Tape, Sealant (Not Shown)	A/R	
32	0700617	Bolt, Metric 6mm x 45mm	1	
33	0237627	Electrical Panel Assembly (See Items 201-211 for Breakdown)	1	
34		Throttle Cable Components (See Figure 2-19 for Breakdown)		
35	0901402	Bracket, Terminal Strip Mounting	1	
36	1320070	Clamp	1	
37	1670414	Cover, Terminal Strip	1	
38	3910812	Screw, Machine #8-32NC x 3/4"	2	
39	4770800	Starwasher #8	2	
40	3310801	Nut #8-32NC	2	
41	1700821	Decal - Wire Identification	1	
42	4843384	Tube, Air Intake	1	

SECTION 2 TURNTABLE

FIGURE 2-17. DEUTZ ENGINE INSTALLATION WITHOUT NOISE REDUCTION (BUILT PRIOR TO OCTOBER 1992) (CONTINUED)

FIG & ITEM #	PART NUMBER	DESCRIPTION	QTY.	REV.
43	3820012	Rivet	2	
44	4750600	Flatwasher #6	2	
45	4921140	Harness, Wiring	1	
46	2420073	Sender, Oil Pressure	1	
47	Not Used			
48	4751400	Flatwasher 1/4"	3	
49	0641416	Bolt 1/4"-20NC x 2"	3	
50 to 60	Not Used			
61		Engine Assembly Options - F4L912:	1	
	2000083	Standard		
	2000115	Clean Burn		
62		Bracket, Mounting (Rear) Options:	1	
	3200306	Standard		
	3200306	Clean Burn	1	
		DEUTZ F4L912 ENGINE INSTALLATION	Ref.	
	0239866	Standard Engine	Ref.	E
	0251168	Clean Burn Engine	Ref.	C
80	1340020	Air Cleaner Assembly	1	
80A	7004214	Filter - 1340020 Air Cleaner	1	
81	0340002	Band, Mounting	2	
82	1120161	Bonnet	1	
83	0080039	Elbow	1	
84	4562928	Tube, Air Intake	1	
85	2720224	Hose	1	
86	1320058	Clamp	4	
87	4300031	Stud (Welded on Part - Not Shown)	11	
88	4761400	Lockwasher 1/4"	11	
89	3311401	Nut 1/4"-20NC	11	
90	0400020	Battery	1	
91	0236768	Rod, Tie-Down	4	
92	0361027	Strap	1	
93	3980006	Seat, Battery	1	
94	0400003	Battery	1	
95	0400002	Tie-Down	1	
96	3980003	Seat, Battery	1	
97	Not Used			
98	3300029	Wingnut 3/8"-16NC	4	
99	1060046	Cable, Battery (- Battery to Ground)	1	
100	1060109	Cable, Battery (+ Battery to Starter)	1	
101	1060149	Cable, Battery (Aux. Relay to Starter)	1	
102	1060132	Cable, Battery (Aux. Relay to Aux Pump)	1	
103	4300034	Stud (Welded on Part)	A/R	
104	4921139	Battery Cable Assembly	1	
105	0642022	Bolt 5/8" - 11NC x 2 3/4"	2	
106	4752000	Flatwasher 5/8"	2	
107	4762000	Lockwasher 5/8"	2	
108	3312001	Nut 5/8"-11NC	2	

SECTION 2 TURNTABLE

FIGURE 2-17. DEUTZ ENGINE INSTALLATION WITHOUT NOISE REDUCTION (BUILT PRIOR TO OCTOBER 1992) (CONTINUED)

FIG & ITEM #	PART NUMBER	DESCRIPTION	QTY.	REV.
109	0641622	Bolt 3/8" - 16NC x 2 3/4"	2	
110	4751600	Flatwasher 3/8"	3	
111	4761600	Lockwasher 3/8"	11	
112	3311601	Nut 3/8"-16NC	12	
113	3600071	Auxiliary Pump Assembly	1	
	7004248	Replacement Motor Only	1	
	7004436	Replacement Motor with Bracket	1	
	7012576	Replacement Mounting Bracket Only	1	
	7004249	Replacement Coupling	1	
	7004247	Replacement Pump	1	
	Not Available	Pump Seal Kit	1	
114	0641610	Bolt 3/8"-16NC x 1 1/4"	2	
115	2720271	Hose, Fuel Return Line	8 ft.	
116	2750532	Hose, Fuel Supply Line	10 ft.	
117	2220063	Fitting, 90°	2	
118	2220720	Fitting, Barbed	2	
119	4751700	Flatwasher 7/16"	2	
120	1320022	Clamp	4	
121	3380375	Baffle	1	
122	4280002	Strip, Neoprene	30 in./76cm	
123	1320059	Clamp	1	
124	2180536	Fitting, Coupling (Not Shown - Located in Fuel Return Line)	1	
125	3533407	Plate, Mounting - Air Cleaner	1	
126	1060031	Cable, Battery (Battery to Ground)	1	
	0237627	ELECTRICAL PANEL ASSEMBLY	Ref.	F
201	3740059	Relay	1	
202	3321001	Nut #10-32NF	3	
203	3310801	Nut #8-32NC	1	
204	3530425	Plate, Mounting	1	
205		Relay Options:	1	
	3740030	Relay, Adlo (Used Prior to April 1991)		
	3740080	Relay, Sealed (Used April 1991 to October 1992)		
206	3740067	Relay	2	
207	3300220	Nut, Special	6	
208	0641405	Bolt 1/4"-20NC x 5/8"	7	
209	4761400	Lockwasher 1/4"	7	
210	3311401	Nut 1/4"-20NC	7	
211	4711400	Flatwasher 1/4" Narrow	6	
	0239915	EXHAUST INSTALLATION	Ref.	D
301		Muffler Options:	1	
	3220058	Prior to July 1990		
	3220077	July 1990 to October 1992		
302	4564359	Pipe, Exhaust	1	
303	1120169	Rain Cap	1	

SECTION 2 TURNTABLE

FIGURE 2-17. DEUTZ ENGINE INSTALLATION WITHOUT NOISE REDUCTION (BUILT PRIOR TO OCTOBER 1992) (CONTINUED)

FIG & ITEM #	PART NUMBER	DESCRIPTION	QTY.	REV.
304	0960960	Tube	1	
305	1320019	Clamp	4	
306	0901719	Bracket, Support	2	
307	0641507	Bolt 5/16"-18NC x 7/8"	2	
308	4751500	Flatwasher 5/16"	2	
309	4761500	Lockwasher 5/16"	2	
310	3311501	Nut 5/16"-18NC	2	
311	0641607	Bolt 3/8"-16NC x 7/8"	1	
312	4751600	Flatwasher 3/8"	1	
313	4761600	Lockwasher 3/8"	1	
314	3311601	Nut 3/8"-16NC	1	
315	2551030	Gusset, Lower (Not Shown)	1	
316	0181504	Angle, Support - Lower (Not Shown)	1	
317		Support Bracket - Upper Options (Not Shown):	1	
	0901636	Prior to July 1990		
	0901720	July 1990 to October 1992		
318	0080117	Adaptor	1	
		SWITCH INSTALLATIONS	Ref.	
	4931671	Engine Distress Installation	Ref.	B
	0251683	Engine Run Light Installation	Ref.	B
	0239119	Generator Installation	Ref.	J
401	2180360	Fitting, Tee	1	
		Switch, Oil Pressure Options:	1	
	4360065	Engine Distress Installation		
	4360037	Engine Run Light Installation		
	4360037	Generator Installation		
	4360179	Switch, Temperature (Engine Distress Installation Only) (Not Shown- Located in Head Under Shroud)	1	
	2180730	Fitting, Adapter (Generator Installation Only)	1	
		ENGINE COMPONENTS (NOT SHOWN)	Ref.	
		Head Repair Components:	A/R	
	70002254	Piston/Cylinder Kit	4	
	70002252	Ring, Head Fire	4	
	70002258	Bolt, Cylinder Head	4	
	70002259	Washer, Cylinder Head	4	
		Engine & Maintenance Kits Components:	A/R	
	70002253	Gasket Kit - Complete Engine	1	
	7020433	Gasket	1	
	7014686	Gasket and Filter Kit - Deutz F4L912 (Includes 3 Different Fuel Line Washers - 12 of each. 1 Oil Plug Washer, 1 Fuel Filter, 1 Oil Filter and 1 Gasket Set)	1	

SECTION 2 TURNTABLE

FIGURE 2-17. DEUTZ ENGINE INSTALLATION WITHOUT NOISE REDUCTION (BUILT PRIOR TO OCTOBER 1992) (CONTINUED)

FIG & ITEM #	PART NUMBER	DESCRIPTION	QTY.	REV.
		Filter/Belt Components:	A/R	
	7000649	Filter, Fuel (was p/n 7000649)	1	
	Use 7029274	Filter, Engine Oil (Case of 12)	1	
	Use 7029276	Filter, Engine Oil (1 Individual Filter) (was p/n 70006489)	1	
	7000697	Belt, Blower	1	
	7000698	Belt, Alternator	1	
		Major Components:	A/R	
	7000663	Alternator (Bosch) (was p/n 7020410 & 7020436)	1	
	7000872	Alternator (Delco-Remy)	1	
	Use 7020413	Starter (was p/n 7000661)	1	
	7020420	Starter, Remanufactured	1	
		Electrical System Components:	A/R	
	7019607	Solenoid, Fuel Shutdown 2nd	1	
	7016330	Switch, Oil Pressure	1	
	Use 7019607	Switch, Solenoid (was p/n 7016341)	1	
	7026173	Switch, Broken Belt	1	
		Fuel System Components:	A/R	
	7016364	Pump, Fuel Lift	1	
	7020432	Repair Kit - Lift Pump	1	
	7020407	Gasket, Lift Pump	1	
	70001361	Pump, Fuel Injection	4	
	7020422	Injector	4	
	7020421	Nozzle, Injector	4	
	7020423	Gasket, Injector Tip	4	
	7016309	Washer, Copper Sealing	4	
	7020400	Washer, Fuel Line	1	
	7020401	Washer, Fuel Line	1	
	7020402	Washer, Fuel Line	1	
	7020403	Washer, Fuel Line	1	
		Intake/Exhaust Components:	A/R	
	70001927	Manifold, Exhaust	1	
	70001928	Gasket, Exhaust Manifold	4	
	7000699	Gasket, Doughnut	1	
	7026125	Flange, Exhaust	1	
		Coupling Components:	A/R	
	7020208	Ring Gear	1	
		Miscellaneous Components:	A/R	
	7020405	Washer, Oil Plug	1	
	7020409	Dipstick	1	
	7020498	Fan	1	
	7027250	Spring, Actuator Tension	1	

SECTION 2 TURNTABLE

FIGURE 2-18. DEUTZ ENGINE INSTALLATION WITH NOISE REDUCTION (BUILT OCTOBER 1992 TO PRESENT)

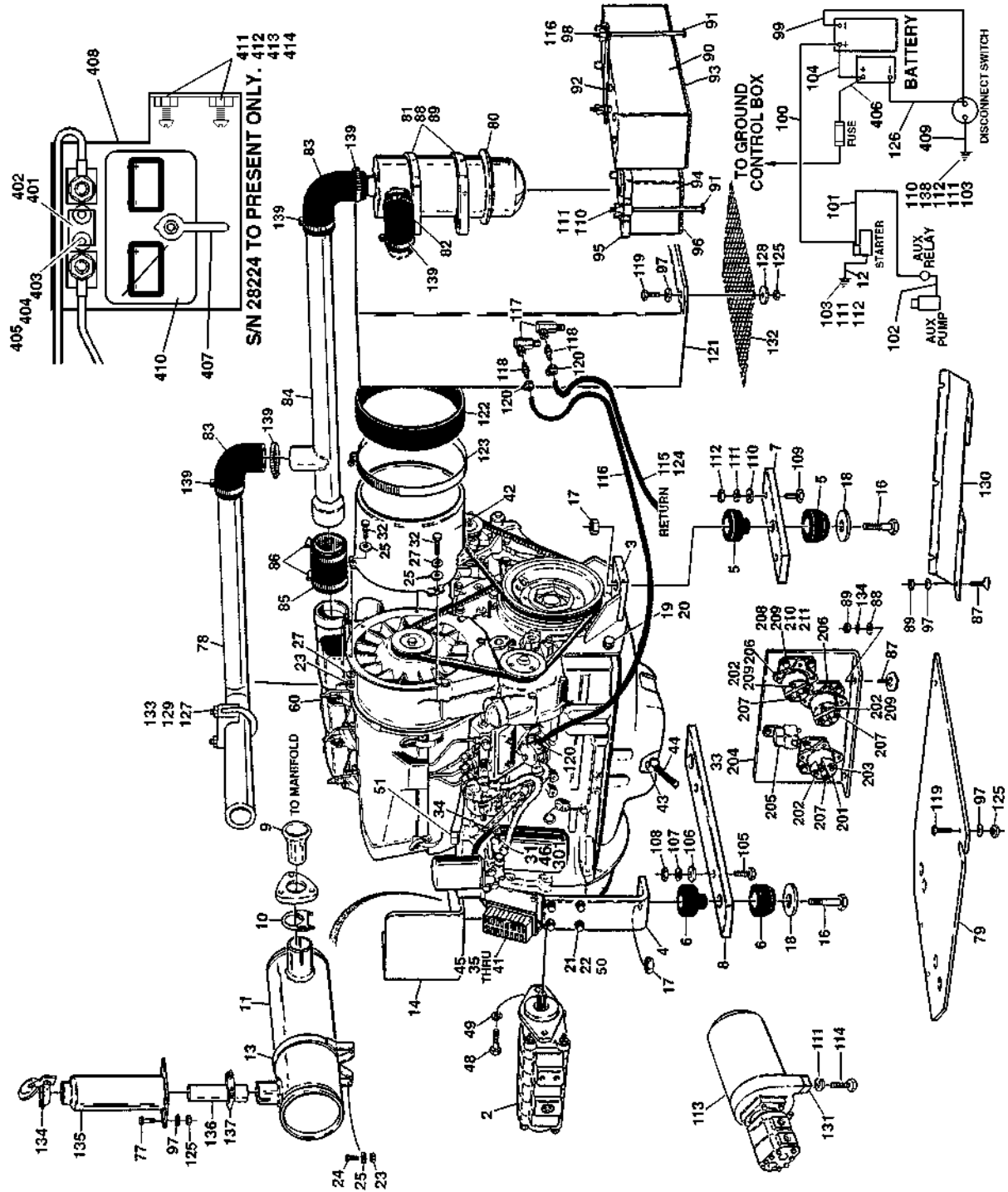

SECTION 2 TURNTABLE

FIGURE 2-18. DEUTZ ENGINE INSTALLATION WITH NOISE REDUCTION (BUILT OCTOBER 1992 TO PRESENT)

FIG & ITEM #	PART NUMBER	DESCRIPTION	QTY.	REV.
		DEUTZ ENGINE ASSEMBLY	Ref.	
	0253357	Standard Engine	Ref.	5
	0253359	Clean Burn Engine	Ref.	4
	0255612	EXHAUST INSTALLATION (STANDARD PARTS) (SEE SECTION 10 FOR NON-STANDARD EXHAUST SYSTEMS)	Ref.	—
1	Not Used			
2	3600139	Pump Assembly (See Figure 2-22 for Breakdown)	1	
3	3200229	Support, Motor (Front)	1	
4	3200228	Support, Motor (Rear)	2	
5	3200133	Mount, Motor (Front)	1	
6	3200183	Mount, Motor (Rear)	2	
7	3200227	Plate, Mounting (Front)	1	
8	3200306	Plate, Mounting (Rear)	1	
9	4565269	Adapter, Exhaust	1	
10	1320011	Clamp, Exhaust	1	
11	3220082	Muffler	1	
12	1060044	Cable, Battery (Engine to Ground)	1	
13	0340041	Band, Muffler	1	
14	0901849	Bracket, Muffler	1	
15	Not Used			
16	0642032	Bolt 5/8"-11NC x 4"	3	
17	3312005	Locknut 5/8"-11NC	3	
18	4740242	Flatwasher, Special	3	
19	0701427	Bolt, Metric 14mm x 100mm	4	
20	4740191	Lockwasher, Metric 14mm	4	
21	0701215	Bolt, Metric 12mm x 35mm	4	
22	4832100	Lockwasher 12mm	8	
23	3290607	Nut, Metric 6mm	4	
	3311405	Nut 1/4"-20NC	2	
24	0641408	Bolt 1/4"-20NC x 1"	2	
25	4811700	Flatwasher 6mm	9	
	4751400	Flatwasher 1/4"	4	
26	Not Used			
27	4831700	Lockwasher 6mm	5	
28	3311401	Nut 1/4"-20NC	3	
29	Not Used			
30	Not Used			
31	4420001	Tape, Sealing	A/R	
32	0700617	Bolt, Metric 6mm x 45mm	5	
33	0237627	Electrical Panel Assembly (See Items 201-211 for Breakdown)	1	
34		Throttle Cable Components (See Figure 2-19 for Breakdown)		
35	0901402	Bracket, Terminal Strip	1	
36	1320070	Clamp	1	
37	1670414	Cover, Terminal Strip	1	
38	3910812	Screw, Machine #8-32NC x 3/4"	2	

SECTION 2 TURNTABLE

FIGURE 2-18. DEUTZ ENGINE INSTALLATION WITH NOISE REDUCTION (BUILT OCTOBER 1992 TO PRESENT) (CONTINUED)

FIG & ITEM #	PART NUMBER	DESCRIPTION	QTY.	REV.
39	4770800	Starwasher #8	2	
40	3310801	Nut #8-32NC	2	
41	1700821	Decal - Wire Identification	1	
42	4843384	Air Intake Weldment	1	
43	4640742	Valve, Drain	1	
44	2720042	Hose, Heater	6 in./15cm	
45	4921140	Engine Harness (Not Shown)	1	
46	2420073	Sender, Oil Pressure	1	
47	Not Used			
48	0641812	Bolt 1/2"-13NC x 1 1/2"	2	
49	4761800	Lockwasher 1/2"	2	
50	0701217	Bolt, Metric 12mm x 45mm (S/N 36614 to Present)	4	
51	1320222	Clamp (S/N 38344 to Present)		
52 to 59	Not Used			
60		Engine, Deutz F4L912 Options:	1	
	2000083	Standard Engine		
	2000115	Clean Burn Engine		
		DEUTZ ENGINE INSTALLATION	Ref.	
	0253358	Standard Engine Installation	Ref.	5
	0253360	Clean Burn Engine Installation	Ref.	4
	0255612	EXHAUST INSTALLATION	Ref.	2
77	0641408	Bolt 1/4"-20NC x 1"	4	
78	4844238	Tube	1	
79	1670627	Cover, Base Plate	1	
80	1340020	Air Cleaner Assembly	1	
	7004214	Filter	1	
81	0340002	Band, Mounting	2	
82	0080046	Elbow	1	
83	0080039	Elbow	A/R	
84	4565655	Tube	1	
85	2720224	Hose	1	
86	1320058	Clamp	A/R	
87	4300031	Stud (Welded on Part)	8	
88	4761400	Lockwasher 1/4"	12	
89	3311401	Nut 1/4"-20NC	12	
90	0400020	Battery	1	
91	0236768	Rod, Tie-Down	4	
92	0361027	Strap, Tie-Down	1	
93	3980006	Seat, Masonite	1	
94	0400003	Battery	1	
95	0400002	Tie-Down, Battery	1	
96	3980003	Seat, Masonite	1	
97	4751400	Flatwasher 1/4"	A/R	
98	3300029	Wingnut 3/8"-16NC	4	
99	1060031	Cable, Battery (- Batt to Ground)	1	
100	1060109	Cable, Battery (+ Batt to Start Solenoid)	1	
101	1060149	Cable, Battery (Start Solenoid to Aux Relay)	1	

SECTION 2 TURNTABLE

FIGURE 2-18. DEUTZ ENGINE INSTALLATION WITH NOISE REDUCTION (BUILT OCTOBER 1992 TO PRESENT) (CONTINUED)

FIG & ITEM #	PART NUMBER	DESCRIPTION	QTY.	REV.
102	1060132	Cable, Battery (Aux Pump to Aux Relay)	1	
103	4300034	Stud (Welded on Part)	3	
104	4921139	Battery Cable Assembly (Includes Diode p/n 3990048)	1	
105	0642020	Bolt 5/8"-20NC x 2 1/2"	2	
106	4752000	Flatwasher 5/8"	2	
107	4762000	Lockwasher 5/8"	2	
108	3312001	Nut 5/8"-20NC	2	
109	0641622	Bolt 3/8"-16NC x 2 3/4"	2	
110	4751600	Flatwasher 3/8"	A/R	
111	4761600	Lockwasher 3/8"	11	
112	3311601	Nut 3/8"-16NC	5	
113	3600071	Auxiliary Pump Assembly - Barnes	1	
	7004248	Motor Assembly	1	
	7004436	Motor Assembly With Mounting Bracket	1	
	7012576	Bracket Only	1	
	7004249	Coupling	1	
	7004247	Pump Assembly	1	
	Not Available	Seal Kit - 7004247 Pump	1	
114	0641620	Bolt 3/8"-16NC x 2 1/2"	2	
115	2720271	Hose, Fuel (Return)	8 ft./2.4m	
116	2750532	Hose, Fuel (Supply)	10 ft./3m	
117	2220063	Fitting, Swivel Adapter	2	
118	2220720	Fitting, Barbed	A/R	
119	0641414	Bolt 1/4"-20NC x 1 3/4"	13	
120	1320022	Clamp, Hose	4	
121	0253194	Inlet Box Assembly	1	
122	4280002	Neoprene	30 in./76cm	
123	1320059	Clamp	1	
124	2180536	Fitting, Barbed	1	
125	3311405	Locknut 1/4"-20NC	13	
126	1060031	Cable, Battery (Aux Relay to Start Relay)	1	
127	4751500	Flatwasher 5/16"	2	
128	4740362	Washer, Fender	6	
129	4761500	Lockwasher 5/16"	2	
130	3535949	Plate, Hose Cover	1	
131	0362101	Bar, Spacer (Prior to S/N 42536)	2	
132	3536008	Plate, Cover	1	
133	1320021	Clamp, Muffler	1	
134	1120423	Raincap	1	
135	4844235	Snorkel	1	
136	4565751	Pipe, Exhaust	1	
137	1320011	Clamp, Exhaust	1	
138	4751700	Flatwasher 7/16"	1	
139	1320016	Clamp (S/N 36614 to Present)	6	

SECTION 2 TURNTABLE

FIGURE 2-18. DEUTZ ENGINE INSTALLATION WITH NOISE REDUCTION (BUILT OCTOBER 1992 TO PRESENT) (CONTINUED)

FIG & ITEM #	PART NUMBER	DESCRIPTION	QTY.	REV.
	0237627	ELECTRICAL PANEL ASSEMBLY	Ref.	9
201	3740059	Relay	1	
202	3321001	Nut #10-32NF	3	
203	3310801	Nut #8-32NC	1	
204	3530425	Plate, Mounting	1	
205	3740080	Relay, Sealed	1	
206	3740067	Relay	2	
207	3300220	Nut, Special	6	
208	0641405	Bolt 1/4"-20NC x 5/8"	7	
209	4791400	Starwasher 1/4"	7	
210	3311401	Nut 1/4"-20NC	7	
211	4711400	Flatwasher 1/4" Narrow	6	
		SWITCH INSTALLATIONS		
	0255152/0255568	Engine Distress Installation	Ref.	3/—
	0251683	Engine Run Light Installation	Ref.	B
	0239119	Generator Installation	Ref.	11
	0255274	Low Oil Pressure Shutdown Installation	Ref.	4
301	2180360	Fitting, Tee	1	
		Switch, Oil Pressure Options:	1	
	4360065	Engine Distress Installation		
	4360037	Engine Run Light Installation		
	4360037	Generator Installation		
	4360065	Low Oil Pressure Shutdown Installation		
	4360179	Switch, Temperature (Engine Distress Installation Only) (Not Shown - Located in Head Under Shroud)	1	
	2180730	Fitting, Adapter (Generator Installation Only)	1	
	2180749	Fitting, 45° (Low Oil Pressure Shutdown Installation Only)	1	
	0257216	BATTERY DISCONNECT INSTALLATION (S/N 28224 TO PRESENT)	Ref.	2/A
401	2400054	Fuse - 35 Amp	1	
402	2400044	Fuseholder	1	
403	0741008	Screw, Flathead #10-24NC x 1"	2	
404	4751000	Flatwasher #10	2	
405	3311005	Locknut #10-24NC	2	
406	4920970	Harness	1	
407	4360155	Switch, Disconnect	1	
408	0902374	Bracket	1	
409	1060044	Cable, Battery	1	
410	1703476	Decal - Battery Connect and Disconnect	1	
411	4300038	Stud (Welded on Part)	2	
412	4751500	Flatwasher 5/16"	2	
413	4761500	Lockwasher 5/16"	2	
414	3311501	Nut 5/16"-18NC	2	

SECTION 2 TURNTABLE

SECTION 2 TURNTABLE

FIGURE 2-18. DEUTZ ENGINE INSTALLATION WITH NOISE REDUCTION (BUILT OCTOBER 1992 TO PRESENT) (CONTINUED)

FIG & ITEM #	PART NUMBER	DESCRIPTION	QTY.	REV.
		ENGINE COMPONENTS (NOT SHOWN)	Ref.	
		Head Repair Components:	A/R	
	70002254	Piston/Cylinder Kit	4	
	70002252	Ring, Head Fire	4	
	70002258	Bolt, Cylinder Head	4	
	70002259	Washer, Cylinder Head	4	
		Engine & Maintenance Kits Components:	A/R	
	70002253	Gasket Kit - Complete Engine	1	
	7020433	Gasket	1	
	7014686	Gasket and Filter Kit - Deutz F4L912 (Includes 3 Different Fuel Line Washers - 12 of each. 1 Oil Plug Washer, 1 Fuel Filter, 1 Oil Filter and 1 Gasket Set)	1	
		Filter/Belt Components:	A/R	
	7000649	Filter, Fuel (was p/n 7000649)	1	
	Use 7029274	Filter, Engine Oil (Case of 12)	1	
	Use 7029276	Filter, Engine Oil (1 Individual Filter) (was p/n 70006489)	1	
	7000697	Belt, Blower	1	
	7000698	Belt, Alternator	1	
		Major Components:	A/R	
	7000663	Alternator (Bosch) (was p/n 7020410 & 7020436)	1	
	7000872	Alternator (Delco-Remy)	1	
	Use 7020413	Starter (was p/n 7000661)	1	
	7020420	Starter, Remanufactured	1	
		Electrical System Components:	A/R	
	7019607	Solenoid, Fuel Shutdown 2nd	1	
	7016330	Switch, Oil Pressure	1	
	Use 7019607	Switch, Solenoid (was p/n 7016341)	1	
	7026173	Switch, Broken Belt	1	
		Fuel System Components:	A/R	
	7016364	Pump, Fuel Lift	1	
	7020432	Repair Kit - Lift Pump	1	
	7020407	Gasket, Lift Pump	1	
	70001361	Pump, Fuel Injection	4	
	7020422	Injector	4	
	7020421	Nozzle, Injector	4	
	7020423	Gasket, Injector Tip	4	
	7016309	Washer, Copper Sealing	4	
	7020400	Washer, Fuel Line	1	
	7020401	Washer, Fuel Line	1	
	7020402	Washer, Fuel Line	1	
	7020403	Washer, Fuel Line	1	
		Intake/Exhaust Components:	A/R	
	70001927	Manifold, Exhaust	1	
	70001928	Gasket, Exhaust Manifold	4	
	7000699	Gasket, Doughnut	1	
	7026125	Flange, Exhaust	1	

SECTION 2 TURNTABLE

SECTION 2 TURNTABLE

FIGURE 2-18. DEUTZ ENGINE INSTALLATION WITH NOISE REDUCTION (BUILT OCTOBER 1992 TO PRESENT) (CONTINUED)

FIG & ITEM #	PART NUMBER	DESCRIPTION	QTY.	REV.
		Coupling Components:	A/R	
	7020208	Ring Gear	1	
		Miscellaneous Components:	A/R	
	7020405	Washer, Oil Plug	1	
	7020409	Dipstick	1	
	7020498	Fan	1	
	7027250	Spring, Actuator Tension	1	

SECTION 2 TURNTABLE

FIGURE 2-18. DEUTZ ENGINE INSTALLATION WITH NOISE REDUCTION (BUILT OCTOBER 1992 TO PRESENT) (CONTINUED)

FIG & ITEM #	PART NUMBER	DESCRIPTION	QTY.	REV.

SECTION 2 TURNTABLE

FIGURE 2-19. ADECO THROTTLE COMPONENTS INSTALLATION - DEUTZ ENGINE MACHINES

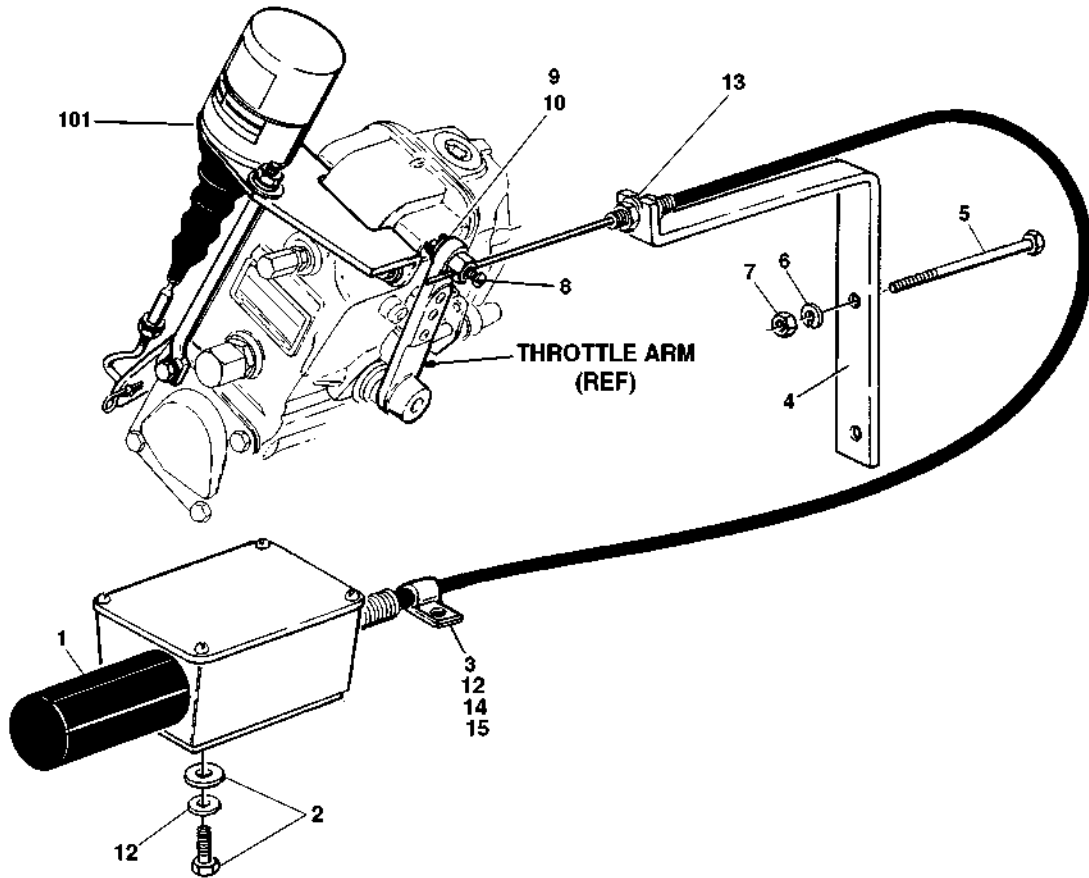
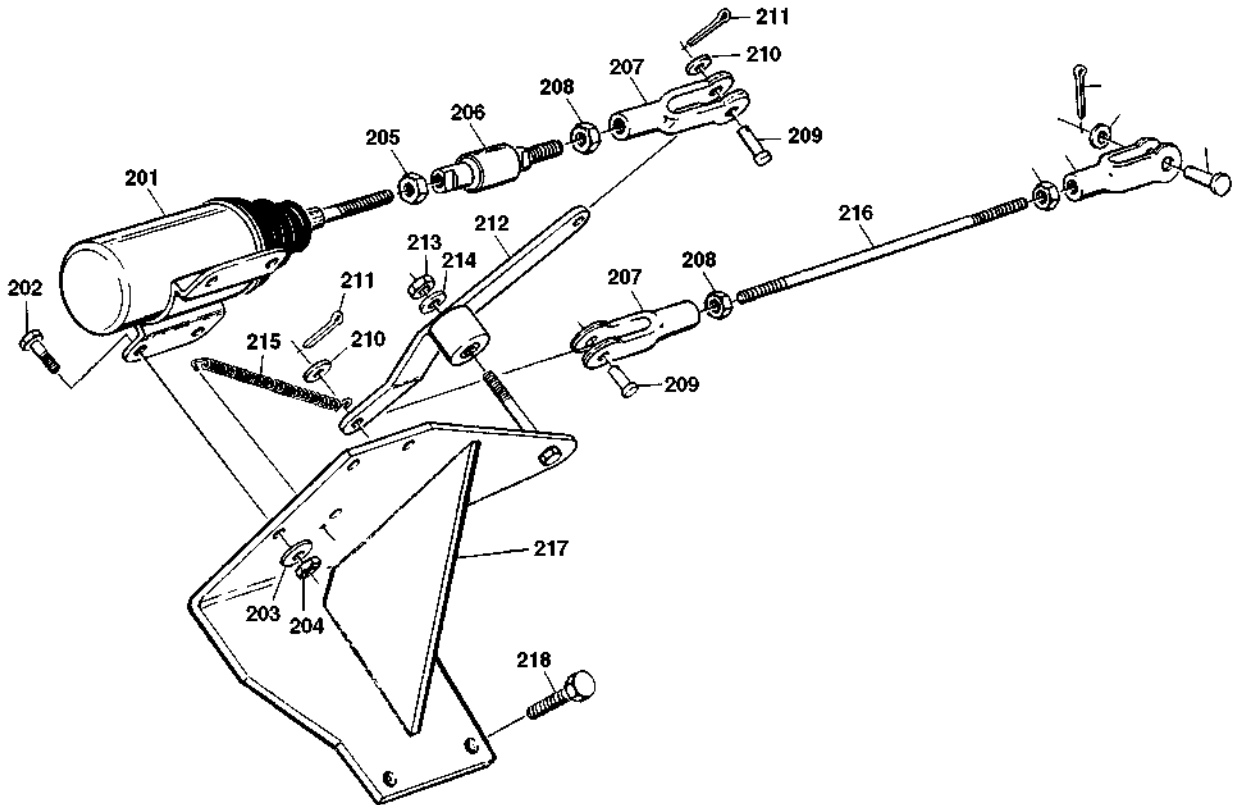

SECTION 2 TURNTABLE

FIGURE 2-19. ADECO THROTTLE COMPONENTS INSTALLATION - DEUTZ ENGINE MACHINES

FIG & ITEM #	PART NUMBER	DESCRIPTION	QTY.	REV.
	0237635	THROTTLE ACTUATOR INSTALLATION (TURNTABLE MOUNTED ACTUATOR)	Ref.	4
1	0060023	Actuator	1	
	7008804	Bellows, Rubber	1	
	7008829	Board, Circuit	1	
	7008821	Motor, Drive	1	
	7008828	Cable, Throttle	1	
2	0641409	Bolt 1/4"-20NC x 1 1/8"	2	
	4751400	Flatwasher 1/4"	2	
3	1320041	Clamp, Cable	2	
4	0901389	Bracket, Cable	1	
5	0630400	Bolt, Metric M8-1.25 x 90MM	2	
6	4831900	Lockwasher Metric 8mm	2	
7	3290801	Nut, Metric M8-1.25	2	
8	4460302	Stop, Cable	1	
9	4711400	Flatwasher 1/4" Narrow	1	
10	3450203	Pin, Cotter 1/16" x 3/4"	1	
11	Not Used			
12	4761400	Lockwasher 1/4"	3	
13	4751600	Flatwasher 3/8"	2	
14	0641406	Bolt 1/4"-20NC x 3/4"	1	
15	3311401	Nut 1/4"-20NC	1	
		STOP-RUN SOLENOID INSTALLATION (GOVERNOR MOUNTED)	Ref.	—
101	0250069	Fuel Shutdown Kit (Includes Mounting Hardware)	1	
	0237631	STOP-RUN SOLENOID INSTALLATION (MOUNTED ON FLYWHEEL HOUSING)	Ref.	—
201	3740055	Solenoid	1	
202	0641406	Bolt 1/4"-20NC x 3/4"	4	
203	4751400	Flatwasher 1/4"	4	
204	3311401	Nut 1/4"-20NC	4	
205	3321401	Nut 1/4"-28NF	1	
206	4160086	Spring, Swivel	1	
207	1360112	Clevis	3	
208	3321401	Nut 1/4"-28NF	1	
209	3430406	Pin, Clevis	3	
210	4751400	Flatwasher 1/4"	3	
211	3450203	Pin, Cotter 1/16" x 3/4"	3	
212	4842269	Arm	1	
213	3311605	Locknut 3/8"-16NC	1	
214	4751600	Flatwasher 3/8"	1	
215	4160024	Spring	1	
216	3840816	Rod	1	
217	4842476	Bracket, Mounting	1	
218	0630136	Bolt, Metric 8MM x 24MM	4	

SECTION 2 TURNTABLE

FIGURE 2-20. GENERATOR INSTALLATIONS - DEUTZ ENGINE MACHINES

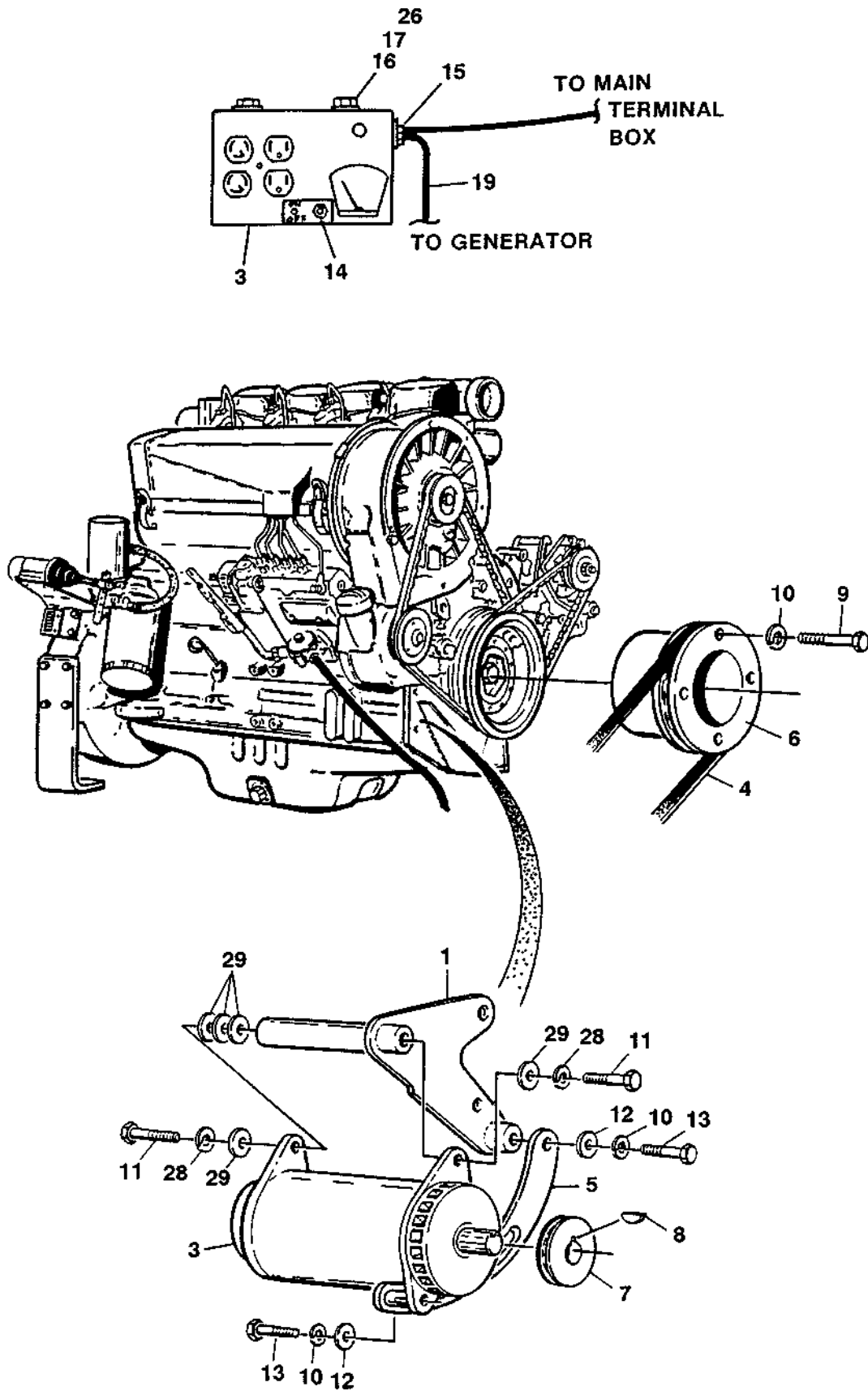

SECTION 2 TURNTABLE

FIGURE 2-20. GENERATOR INSTALLATIONS - DEUTZ ENGINE MACHINES

FIG & ITEM #	PART NUMBER	DESCRIPTION	QTY.	REV.
	0239119	GENERATOR INSTALLATION- DEUTZ	Ref.	11
1	4843133	Bracket, Generator Mounting	1	
2	Not Used			
3	2460011	Generator and Control Box Assembly	1	
	7012558	Generator Only (Includes Item 7)	1	
	7027887	Key, Woodruff	1	
	7020193	Cord, Power	1	
	7026199	Armature	1	
	7020108	Brushes	4	
	7020109	Holder, Brush	4	
	7012513	Cap, Brush Holder	4	
	7012514	Fan	1	
	7020110	Bell, Front End	1	
	7020111	Bell, Rear End	1	
	7020190	Bearing	2	
	7003657	Box, Control	1	
		Note: Replacement 110V Control Box comes with 2 std. Receptacles p/n 4460190. Optional Industrial Twist Lock Receptacle p/n 4460027 must be ordered separately.		
	4360542	Circuit Breaker	1	
	2420203	Voltmeter	1	
	4460190	Receptacle	2	
	2920162	Lamp	1	
	7020191	Switch, Toggle	1	
4	0480050	V-Belt	1	
5	4340511	Support, Adjustment	1	
6	3580109	Pulley	1	
7	3580134	Pulley (Part of Item 3)	1	
8	2860012	Key, Woodruff	1	
9	0700821	Bolt, Metric 8m x 65mm	4	
10	4761500	Lockwasher 5/16"	6	
11	0681610	Bolt 3/8"-16NC x 1 1/4" (Grade 8)	2	
12	4751500	Flatwasher 5/16"	A/R	
13	0641507	Bolt 5/16"-18NC x 7/8"	2	
14	3251476	Nameplate - On/Off	1	
15	4460023	Connector	1	
16	4300031	Stud (Welded on Part)	2	
17	4761400	Lockwasher 1/4"	2	
18	Not Used			
19	4920039	Wire - Red	12ft/3.7m	
20 to 21	Not Used			
22	2180360	Fitting, Tee (Not Shown - Located on Engine)	1	
23 to 24	Not Used			
25	4360037	Switch, Oil Pressure (Not Shown - Located on Engine)	1	
26	3311401	Nut 1/4"-20NC	2	
27	2180730	Fitting, Adapter (Not Shown - Located on Engine)	1	
28	4761600	Lockwasher 3/8"	2	
29	4751600	Flatwasher 3/8"	4	

SECTION 2 TURNTABLE

FIGURE 2-21. PUMP COUPLING INSTALLATION

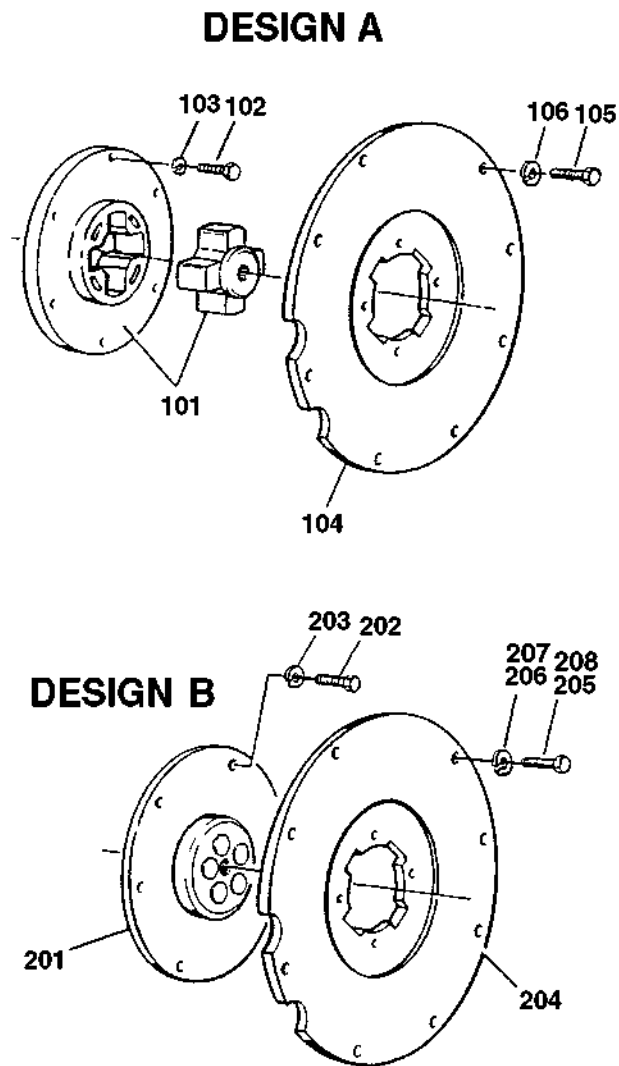

SECTION 2 TURNTABLE

FIGURE 2-21. PUMP COUPLING INSTALLATION

FIG & ITEM #	PART NUMBER	DESCRIPTION	QTY.	REV.
	0239954	LOVEJOY COUPLING INSTALLATION (DEUTZ ENGINES WITH DESIGN A)	Ref.	—
101	1660170	Coupling - Lovejoy	1	
	1660174	Disc, Coupling	1	
	1660175	Hub, Coupling	1	
102	0701014	Bolt, Metric 10mm x 30mm	6	
103	4832000	Lockwasher 10mm	6	
104	0080164	Adapter, Pump	1	
105	0701014	Bolt, Metric 10mm x 30mm	12	
106	4832000	Lockwasher 10mm	12	
	0250600	HAYES COUPLING INSTALLATION (DEUTZ ENGINES WITH DESIGN B)	Ref.	2
201	1660183	Coupling	1	
202	0701010	Bole, Metric 10mm x 20mm	6	
203	4832000	Lockwasher 10mm	6	
204	0080164	Adapter, Pump	1	
205	0701014	Bolt, Metric 10mm x 30mm	10	
206	4832000	Lockwasher 10mm	18	
207	0701015	Bolt, Metric 10mm x 35mm (S/N 36560 to Present)	2	
208	4751600	Flatwasher 3/8" (S/N 36560 to Present)	2	

SECTION 2 TURNTABLE

FIGURE 2-22. MAIN PUMP ASSEMBLY

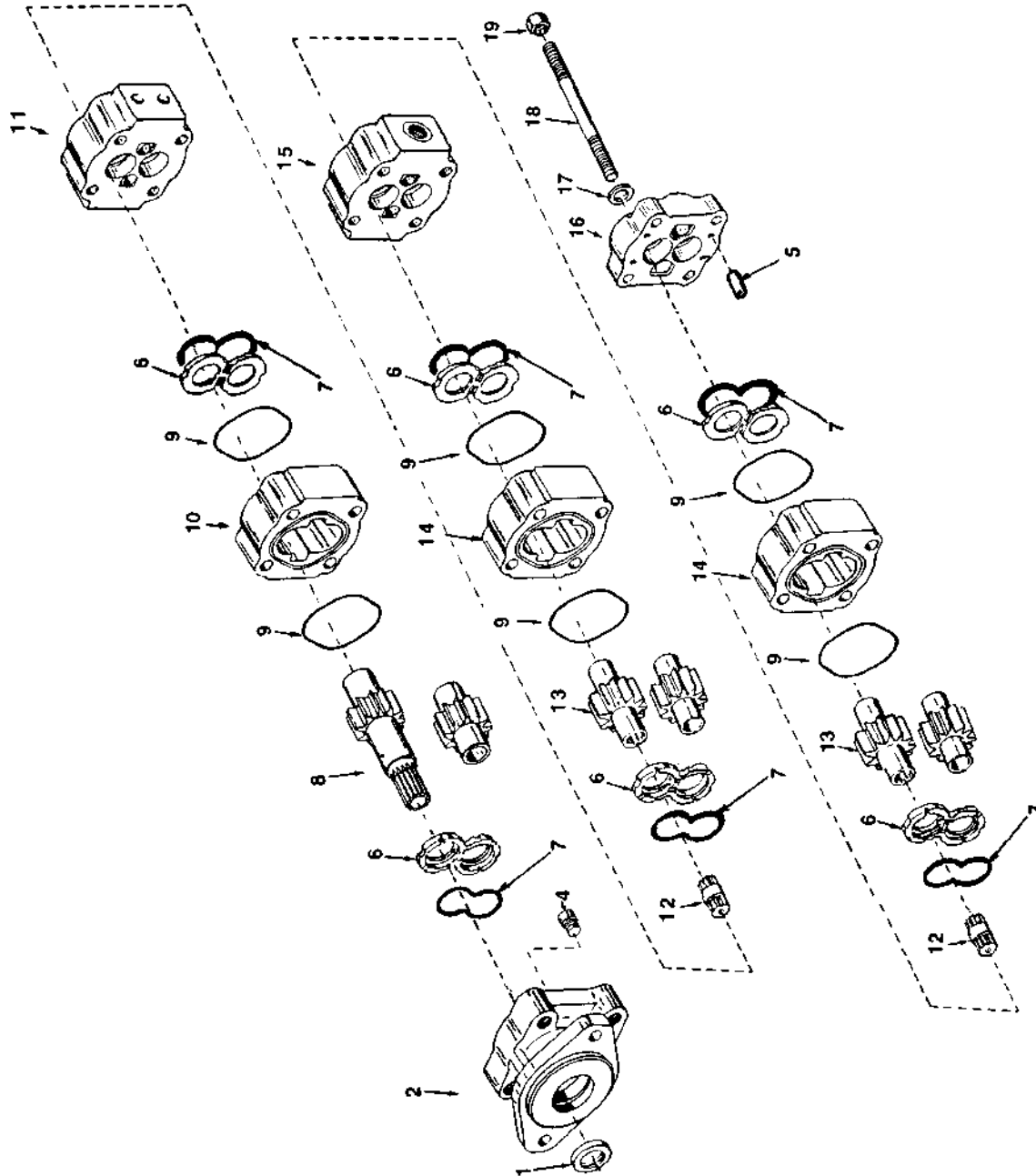

SECTION 2 TURNTABLE

FIGURE 2-22. MAIN PUMP ASSEMBLY

FIG & ITEM #	PART NUMBER	DESCRIPTION	QTY.	REV.
	3600139	MAIN PUMP ASSEMBLY	Ref.	B
1	Kit	Seal, Lip	1	
2	7009513	Cover, End with Bushings	1	
3	Not Used			
4	7003103	Plug	1	
5	7009500	Dowel	12	
6	7009503	Plate, Thrust	6	
7	Kit	Seal, Channel	6	
8	7009509	Shaft and Gear	1 Set	
9	Kit	Seal, Gasket	6	
10	7009510	Housing, Gear	1	
11	7009508	Carrier, Bearing with Bushings	1	
12	7005599	Shaft, Connecting	2	
13	7005598	Gear Set	2	
14	7009504	Housing, Gear	1	
15	7009505	Carrier, Bearing with Bushings	1	
16	7009511	Cover, Rear with Bushings	1	
17	7005597	Washer	4	
18	7005562	Stud	4	
19	7005595	Nut	4	
	2900673	Seal Kit (Includes Items 1,7 and 9)	1	

SECTION 2 TURNTABLE

FIGURE 2-23. TANKS INSTALLATION

FIG & ITEM #	PART NUMBER	DESCRIPTION	QTY.	REV.
		NOTE: For Machines with Oversize Tanks see Section 10.		
	0239857	FUEL AND HYDRAULIC INSTALLATION	Ref.	3
1		Fuel Tank Assembly Options (See Items 101-151 for Breakdown):	1	
	4400279	Tank - Prior to June 1995		
	4400386	Tank - June 1995 to Present		
2	4400278	Hydraulic Tank Assembly (See Items 201 - 257 for Breakdown)	1	
3	0641614	Bolt 3/8"-16NC x 1 3/4"	4	
4	4751600	Flatwasher 3/8"	8	
5	4761600	Lockwasher 3/8"	8	
6	3311601	Nut 3/8"-16NC	8	
7	0641616	Bolt 3/8"-16NC x 2"	3	
8	1340046	Breather	1	
9	4300034	Stud (Welded on Part - Not Shown)	1	
10	4070410	Shim 1/16"	A/R	
11	4070411	Shim 1/8"	A/R	
12	4070412	Shim 3/16"	A/R	
		FUEL TANK ASSEMBLY OPTIONS:	Ref.	
	4400279	MACHINES BUILT PRIOR TO JUNE 1995	Ref.	B
	4400386	MACHINES BUILT JUNE 1995 TO PRESENT	Ref.	2
101	Not Used	Tank, Fuel Options:	1	
	4400280	Machines Built Prior to June 1995		
	4400387	Machines Built June 1995 to Present		
102	Not Used			
103	4060574	Protector, Gauge	1	
104	4562516	Tube, Sight	15 in./38cm	
105	Not Used			
106	1320022	Clamp, Hose	2	
107	3311401	Nut 1/4"-20NC	3	
108	4761400	Lockwasher 1/4"	3	
109	Not Used			
110	2200052	Plug, Pipe	1	
111	0100020	Sealant, Pipe (Not Shown)	A/R	
112	2180467	Fitting, Barbed 90°	2	
113	33000205	Nut, Retainer	3	

SECTION 2 TURNTABLE

SECTION 2 TURNTABLE

FIGURE 2-23. TANKS INSTALLATION (CONTINUED)

FIG & ITEM #	PART NUMBER	DESCRIPTION	QTY.	REV.
	4400278	HYDRAULIC TANK ASSEMBLY	Ref.	B
201	Not Used			
202	2120103	Filter Assembly	1	
202A	2120107	Element, Filter	1	
202B	7004244	Indicator, Pressure	1	
202C	7012559	Gasket - Between Tank and Filter	1	
202D	7016333	O-Ring - Under Cap	1	
203	4740338	Washer, Sealing	6	
204	2420080	Gauge, Level	1	
	7016664	Washer, Sealing - Viton	1	
205	1340045	Strainer	1	
206	1670468	Lid	1	
207	Not Used			
208	2180605	Pipe	1	
209	3520022	Plug, Magnetic	1	
210	0641612	Bolt 3/8"-16NC x 1 1/2"	4	
211	4761600	Lockwasher 3/8"	4	
212	3311601	Nut 3/8"-16NC	4	
213	2180606	Nipple, Pipe	1	
214	2120104	Filter	1	
215	3311401	Nut 1/4"-20NC	12	
216	4761400	Lockwasher 1/4"	12	
217	0100020	Sealant, Pipe (Not Shown)	A/R	
218	2200268	Fitting, Coupling	1	
219	2200203	Plug, Pipe 1/2"	1	
220	3300205	Nut, Retainer 5/16"-18NC	3	
221	2180614	Fitting, Straight	1	
222	2220728	Fitting, Tee	1	
223	3960371	Gasket	1	
224	4751400	Flatwasher 1/4"	14	
225	4740322	Washer, Sealing	4	
226 to 249	Not Used			
250	4400277	Tank Weldment	1	
		FUEL CAP ASSEMBLY	Ref.	
	0236285	Standard Fuel Cap	Ref.	5/E
	0257365	Standard Fuel Cap	Ref.	1
	0257366	Protectoseal (Red) Fuel Cap	Ref.	2
	0258626	Protectoseal (Blue) Fuel Cap (S/N 38057 To Present)	Ref.	1
301		Cap, Fill Options:	1	
	1120314	Standard Fuel Cap		
	1120367	Protectoseal (Red) Fuel Cap		
	1120512	Protectoseal (Blue) Fuel Cap (S/N 38057 To Present)		

SECTION 2 TURNTABLE

FIGURE 2-23. TANKS INSTALLATION (CONTINUED)

FIG & ITEM #	PART NUMBER	DESCRIPTION	QTY.	REV.

SECTION 2 TURNTABLE

FIGURE 2-24. GROUND CONTROLS INSTALLATION

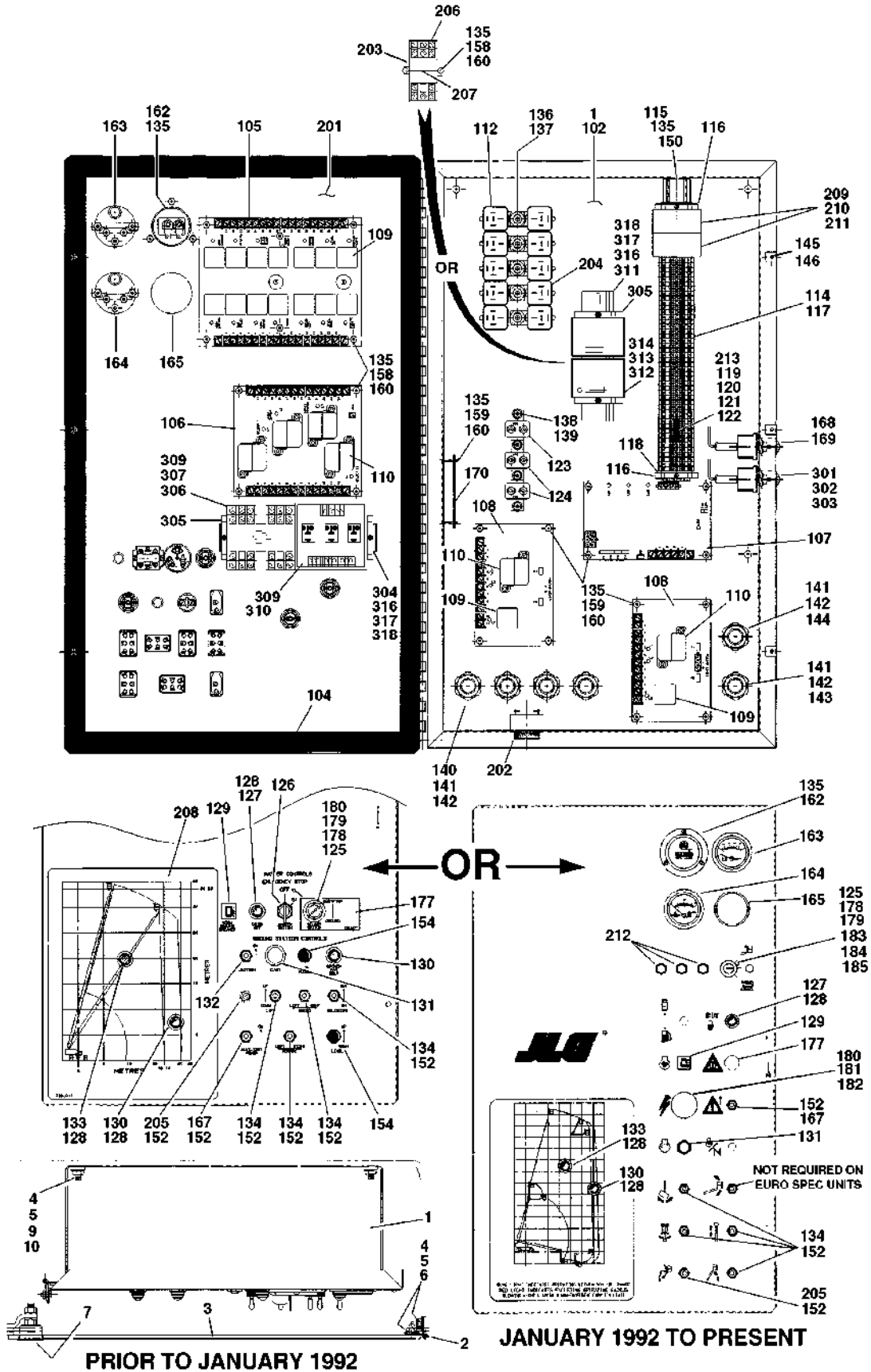

SECTION 2 TURNTABLE

FIGURE 2-24. GROUND CONTROLS INSTALLATION

FIG & ITEM #	PART NUMBER	DESCRIPTION	QTY.	REV.
	0251169	GROUND CONTROLS INSTALLATION (100HX BUILT PRIOR TO S/N 28224)	Ref.	B
	0257231	GROUND CONTROLS INSTALLATION (100HX BUILT S/N 28224 TO S/N37394)	Ref.	1
	0258188	GROUND CONTROLS INSTALLATION (100HX BUILT S/N 37394 TO PRESENT)	Ref.	1
	0251170	GROUND CONTROLS INSTALLATION (110HXER & 100HX+10)	Ref.	B
	0257232	GROUND CONTROLS INSTALLATION (110HXER & 100HX+10 BUILT S/N 28224 TO PRESENT)	Ref.	1
	0251169	GROUND CONTROLS INSTALLATION (110HX BUILT PRIOR TO S/N 28224)	Ref.	B
	0257231	GROUND CONTROLS INSTALLATION (110HX BUILT S/N 28224 TO PRESENT)	Ref.	1
1		Ground Control Box Assembly (See Items 101-220 for Breakdown)	1	
2	2600148	Hinge	1	
3	1780227	Door, Ground Control	1	
4	4751400	Flatwasher 1/4"	14	
5	3311405	Locknut 1/4"-20NC	14	
6	4300031	Stud (Welded on Part)	5	
7	2940042	Latch	1	
8	0100011	Loctite #242 (Not Shown)	A/R	
9	4300032	Stud (Welded on Part)	4	
10	4751500	Flatwasher 5/16"	8	
	0860678	CONTROL BOX ASSEMBLY (100HX BUILT PRIOR TO S/N 28224) (VARIABLE PARTS)	Ref.	11
	0861095	CONTROL BOX ASSEMBLY (100HX BUILT S/N 28224 TO S/N 37394) (VARIABLE PARTS)	Ref.	6
	0861194	CONTROL BOX ASSEMBLY (100HX BUILT S/N 37394 TO PRESENT) (VARIABLE PARTS)	Ref.	3
	0860678	CONTROL BOX ASSEMBLY (110HX BUILT PRIOR TO S/N 28224) (VARIABLE PARTS)	Ref.	11
	0861095	CONTROL BOX ASSEMBLY (110HX BUILT S/N 28224 TO PRESENT) (VARIABLE PARTS)	Ref.	6
	0860679	CONTROL BOX ASSEMBLY (110HXER AND 100HX+10 BUILT PRIOR TO S/N 28224) (VARIABLE PARTS)	Ref.	12
	0861096	CONTROL BOX ASSEMBLY (110HXER AND 100HX+10 BUILT S/N 28224 TO PRESENT) (VARIABLE PARTS)	Ref.	5
101	Not Used			
102	0860562	Box	1	
103	Not Used			
104	4420008	Gasket	15 ft./4.5m	
105	0610084	Card, Circuit (Engine Relay)	1	
106	0610080	Card, Circuit (Select)	1	

SECTION 2 TURNTABLE

FIGURE 2-24. GROUND CONTROLS INSTALLATION (CONTINUED)

FIG & ITEM #	PART NUMBER	DESCRIPTION	QTY.	REV.
107		Card, Circuit (Load Radius) Options:		
	0610083	Prior to April 1993		
	0610106	April 1993 to S/N 44618		
	0610130	S/N 44618 to Present		
108	0610100	Card, Circuit (Overload)	2	
109	3740070	Relay - SPDT	16	
110	3740016	Relay - 3PDT	A/R	
111	Not Used			
112	3740049	Relay - 5PDT (With Skirt)	9	
113	Not Used			
114	4460301	Marker, Terminal (1-50)	1	
115	3640686	Rail	1	
116	4460299	Stop, Terminal	2	
117	4460298	Block, Terminal	47	
118	4460300	Barrier, Terminal	1	
119	4460307	Sleeve, Terminal	A/R	
120		Bar, Buss Option:	1	
	4460311	5 Position		
	4460308	2 Position		
121	4460306	Washer, Terminal	A/R	
122	4460305	Screw, Terminal	A/R	
123	4360216	Breaker, Circuit - 30 Amp	1	
124	4360232	Breaker, Circuit - 15 Amp	2	
125		Switch, Toggle (Select) Options:	1	
	4360275	Prior to January 1992		
	4360284	January 1992 to S/N 47729		
	4360468	S/N 47729 to Present		
126	4360003	Switch, Key (Master Switch) (Prior to January 1992 Only)	1	
	2860002	Key, Replacement (Prior to January 1992 Only)	1	
127	2920027	Light, Indicator - Green (Axles Set)	1	
128	2920029	Bulb, Light	3	
129	4360212	Breaker, Circuit - 3 Amp	1	
130	2920026	Light, Indicator - Red (Radius Limit)	1	
	2920026	Light, Indicator - Red (Broken Fan Belt Light - Prior to January 1992 Only)	1	
131	4360274	Switch, Push Button (Start)	1	
132	4360199	Switch, Toggle (Ignition) (Prior to January 1992 Only)	1	
133	2920090	Light, Indicator - Blue (Capacity Limit)	1	
134	4360202	Switch, Toggle	4	
135	4760600	Lockwasher #6	A/R	
136	4751400	Flatwasher 1/4"	A/R	
137	3311401	Nut 1/4"-20NC	A/R	
138	4751000	Flatwasher #10	A/R	
139	3311001	Nut #10-24NC	A/R	
140	4460051	Connector, Strain Relief	4	
141	3300048	Nut, Conduit	6	
142	0960238	Bushing, Reducer	6	
143	4460071	Connector, Strain Relief	1	

SECTION 2 TURNTABLE

FIGURE 2-24. GROUND CONTROLS INSTALLATION (CONTINUED)

FIG & ITEM #	PART NUMBER	DESCRIPTION	QTY.	REV.
144	4460244	Connector, Strain Relief	1	
145	3300177	Nut, Tinnerman	3	
146	0750806	Screw, Self-Tapping #8 x 3/4"	3	
147	0720803	Screw, Hex #8-32NC x 3/8"	6	
148	4760800	Lockwasher #8	6	
149	3310801	Nut #8-32NC	6	
150	0720603	Screw, Hex #6-32NC x 3/8"	2	
151	Not Used			
152	3790012	O-Ring	A/R	
153	4460234	Clamp, Cable (Not Shown)	10	
154	3520028	Plug, Hole (Prior to January 1992 Only)	2	
155	Not Used			
156	Not Used			
157	Not Used			
158	3910616	Screw, Hex #6-32NC x 1"	A/R	
159	4564088	Stand-Off #6-32NC x 1/4"	A/R	
160	3310601	Nut #6-32NC	A/R	
161	Not Used			
162	2420009	Hourmeter	1	
163	2420091	Voltmeter	1	
164	2420074	Gauge, Oil Pressure	1	
165	3520070	Plug, Hole	1	
166	Not Used			
167	4360200	Switch, Toggle (Auxiliary Power)	1	
168	4360198	Switch, Toggle (Proximity Manual Test)	1	
169	4060229	Guard, Switch	1	
170	0610091	Card, Circuit (Drive Accessories)	1	
171 to 176	Not Used			
172	Not Used			
177	3252023	Nameplate (Prior to January 1992)	1	
	2920015	Lamp (January 1992 to Present)	1	
178	4360267	Block, Contact - SPST (Prior to S/N 49405)	1	
179	4360281	Block, Contact (Prior to S/N 49405)	3	
180		Block, Contact Options:	1	
	4360282	Prior to S/N 47729		
	4360476	S/N 47729 to Present		
181		Switch, Emergency Stop Options:	1	
	4360289	Prior to S/N 47729		
	4360475	S/N 47729 to Present		
		Cap Options:	1	
	7012611	Cap, Mushroom Head (Used on Switch p/n 4360289)		
	7012612	Boot (Used on Switch p/n 4360289)	1	
	7020175	Cap, Red (Used on Switch p/n 4360475)		
	7020176	Contact Block (Used on Switch p/n 4360475)		
182	1704260	Decal - EMS (S/N 47729 to Present)	1	
183	4070987	Shim .015 (S/N 47729 to Present)	1	
184	4070991	Shim .125 (S/N 47729 to Present)	1	
185	3910804	Screw #8-32NC x 1/4" (S/N 47729 to Present)	6	
186 to 200	Not Used			

SECTION 2 TURNTABLE

SECTION 2 TURNTABLE

FIGURE 2-24. GROUND CONTROLS INSTALLATION (CONTINUED)

FIG & ITEM #	PART NUMBER	DESCRIPTION	QTY.	REV.
201		Lid/Nameplate Options:	1	
		100HX:		
	3251856	Prior to October 1991		
	3252146	October 1991 to May 1994		
	3252359	May 1994 to S/N 33726		
	3252545	S/N 33726 to S/N 37394		
	3252659	S/N 37394 to Present		
		110HX:		
	3251856	Prior to October 1991		
	3252146	October 1991 to May 1994		
	3252359	May 1994 to S/N 33726		
	3252545	S/N 33726 to S/N 47729		
	3252655	S/N 47729 to Present		
		100HX+10 & 110HXER		
	3251857	Prior to October 1991		
	3252148	October 1991 to May 1994		
	3252360	May 1994 to S/N 33726		
	3252546	S/N 33726 to S/N 47729		
	3252656	S/N 47729 to Present		
202		Alarm Options:	1	
	0140019	Prior to S/N 28224		
	0140011	S/N 28224 to Present		
203		Relay - 3PDT Options:	A/R	
	Not Required	100HX & 110HX	0	
	3740016	100HX+10 & 110HXER	1	
204		Relay - 5PDT (With Skirt) Options:	A/R	
	Not Required	100HX & 110HX	0	
	3740049	100HX+10 & 110HXER	1	
205		Switch, Toggle (Extend-A-Reach)	A/R	
	Not Required	100HX & 110HX	0	
	4360202	100HX+10 & 110HXER	1	
206		Base, Relay Options:	A/R	
	Not Required	100HX & 110HX	0	
	4120002	100HX+10 & 110HXER	1	
207		Spring, Relay Options:	A/R	
	Not Required	100HX & 110HX	0	
	4160025	100HX+10 & 110HXER	1	
208		Nameplate Options:	1	
	3252017	Prior to January 1992		
	Not Required	January 1992 to Present		
209		Socket, Relay Options:	2	
	4120013	Prior to S/N 28224		
	4120037	S/N 28224 to Present		
210		Relay Options:	2	
	3740058	Prior to S/N 28224		
	3740123	S/N 28224 to Present		
211		Spring, Relay Options:	2	
	3740063	Prior to S/N 28224		
	3740124	S/N 28224 to Present		

SECTION 2 TURNTABLE

FIGURE 2-24. GROUND CONTROLS INSTALLATION (CONTINUED)

FIG & ITEM #	PART NUMBER	DESCRIPTION	QTY.	REV.
212		Breaker, Circuit - 10 Amp Options:	A/R	
	Not Required	Prior to S/N 28224	0	
	4360069	S/N 28224 to Present	3	
213		Bar, Buss - 3 Position Options:	A/R	
	Not Required	100HX & 110HX	0	
	Not Required	100HX+10 & 110HXER Prior to S/N 28224	0	
	4460309	100HX+10 & 110HXER S/N 28224 to Present	1	
	0253378	TUV MONITORING SYSTEM INSTALLATION (110HXER AND 100HX+10)	Ref.	C/2
301	3790012	O-Ring	1	
302	4360202	Switch, Toggle	1	
303	4060229	Switch, Guard	1	
304	3640930	Rail Mounting	1	
305	4460299	Stop, Terminal	5	
306	3740019	Relay, Latch	2	
307	4120028	Socket, Relay	2	
308	4160112	Spring, Relay	2	
309	3740086	Relay	3	
310	4120029	Socket, Relay	1	
311	3640555	Rail Mounting	1	
312	3740090	Time Delay, Relay	2	
313	4120030	Socket, Relay	2	
314	4160112	Spring, Relay	2	
315	Not Used			
316	0720603	Screw #6-32 x 3/8"	4	
317	4760600	Lockwasher #6	4	
318	3310601	Nut #6-32	4	

SECTION 2 TURNTABLE

FIGURE 2-25. LOAD MANAGEMENT INSTALLATION

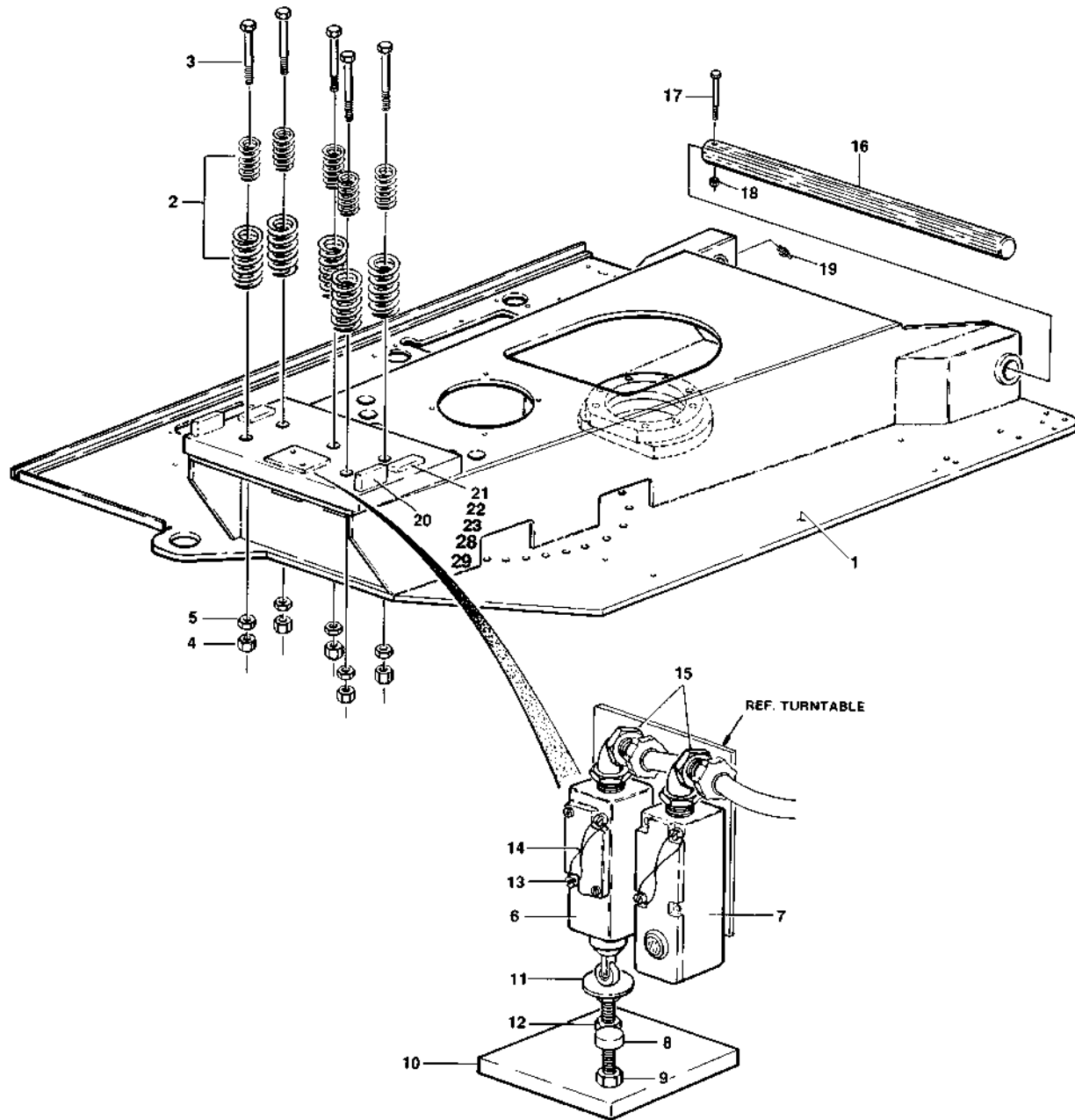

SECTION 2 TURNTABLE

FIGURE 2-25. LOAD MANAGEMENT INSTALLATION

FIG & ITEM #	PART NUMBER	DESCRIPTION	QTY.	REV.
	0239868	LOAD MANAGEMENT INSTALLATION	Ref.	7
1		Base Weldment Options:	1	
	4843310	Prior to May 1992		
	4844080	May 1992 to September 1992		
	4844272	September 1992 to Present		
2	4160099	Spring	5	
3	0630422	Bolt 1 1/4"-&NC x 14"	5	
4	3313002	Nut, Jam 1 1/4"-7NC	5	
5	3273001	Nut 1 1/4"-7NC (Grade 8)	5	
6	4360263	Switch, Limit	1	
7	4360259	Switch, Proximity	1	
8	3841004	Rod, Actuator	1	
9	3321501	Nut 5/16"-18	1	
10	3533414	Plate, Actuator Mounting	1	
11	4843128	Actuator, Switch (Prior to S/N 27316)	1	
	0630510	Bolt, Leveler (S/N 27316 to Present)	1	
12	3321405	Locknut 1/4"-28NF	1	
13	3900104	Screw, Drilled Head #10-24NC x 2 1/4"	4	
14	4920140	Lockwire	2	
15	4460342	Connector, Strain Relief	2	
16	3421677	Pin, Load Moment Pivot	1	
17	0642252	Bolt 3/4"-10NC x 6 1/2"	1	
18	3312205	Locknut 3/4"-10NC	1	
19	2160002	Fitting, Grease	2	
20	4220120	Stop, Turntable	2	
21	4220121	Stop, Turntable	A/R	
22	4070729	Shim 11 GA x 1 1/2" x 4"	A/R	
23	4070728	Shim 16 GA x 1 1/2" x 4"	A/R	
24	Not Used			
25	Not Used			
26	Not Used			
27	Not Used			
28	4220157	Stop, Turntable 1/2" x 1 1/2" x 4"	A/R	
29	4220158	Stop, Turntable 1/4" x 1 1/2" x 4"	A/R	
	0100019	----- Loctite	A/R	

SECTION 2 TURNTABLE

FIGURE 2-26. HOODS AND ALARM INSTALLATION (MACHINES WITH 4620044 TURNTABLE)

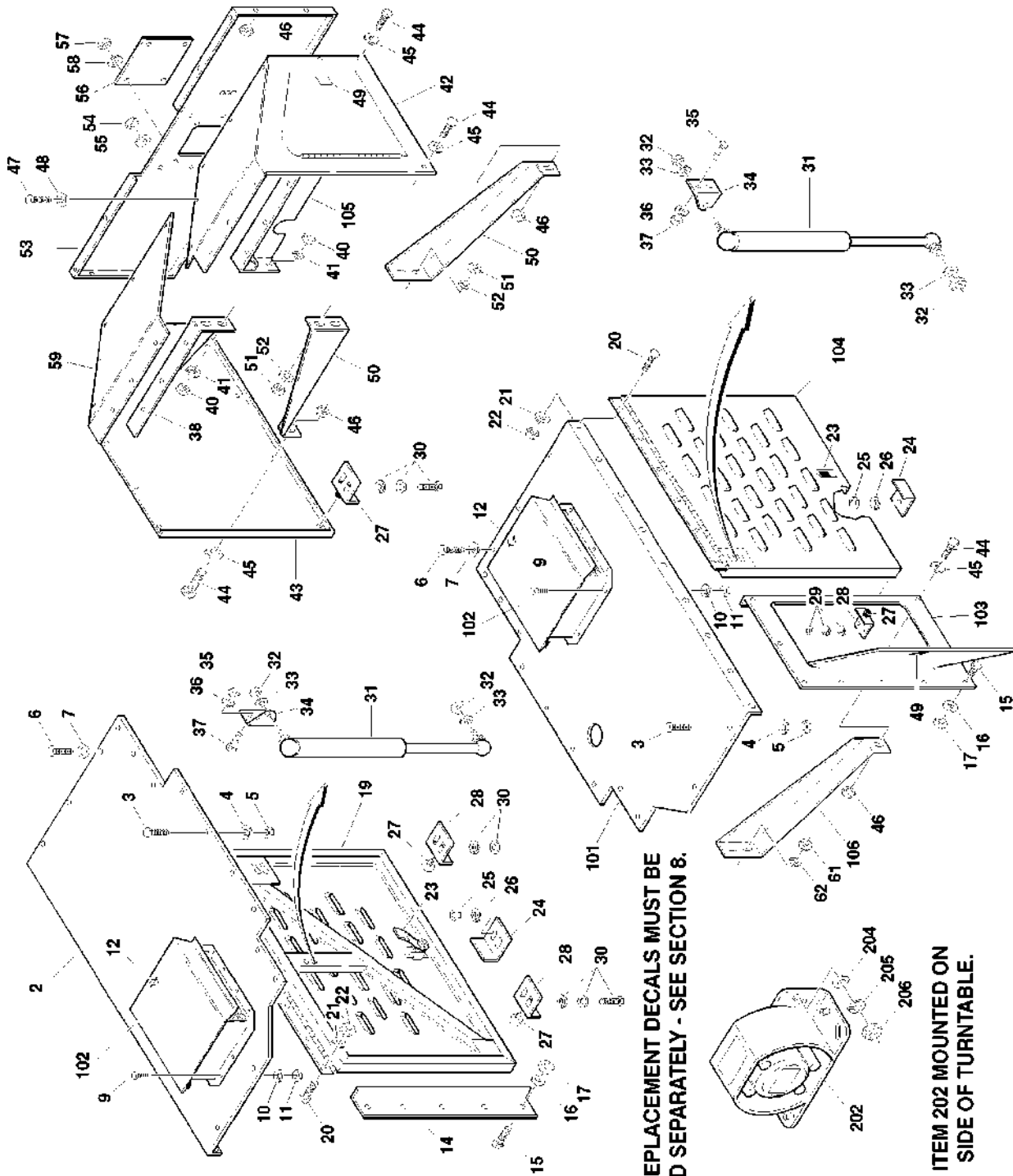

SECTION 2 TURNTABLE

FIGURE 2-26. HOODS AND ALARM INSTALLATION (MACHINES WITH 4620044 TURNTABLE)

FIG & ITEM #	PART NUMBER	DESCRIPTION	QTY.	REV.
		HOOD INSTALLATION (STANDARD PARTS)	Ref.	
1	Not Used			
2	4843337	Panel - Top Hood (Right Side)	1	
3	0641408	Bolt, 1/4"-20NC x 1"	10	
4	4751400	Flatwasher 1/4"	10	
5	3311405	Locknut 1/4"-20NC	10	
6	3941405	Screw, Self Tap 1/4"-20NC x 5/8"	4	
7	4761400	Lockwasher 1/4"	4	
8	Not Used			
9	0641406	Bolt 1/4"-20NC x 3/4"	16	
10	4751400	Flatwasher 1/4"	16	
11	3311405	Locknut 1/4"-20NC	16	
12	2940051	Latch	2	
13	Not Used			
14	1780172	Panel - Side (Right Side)	1	
15	0641406	Bolt 1/4"-20NC x 3/4"	5	
16	4751400	Flatwasher 1/4"	5	
17	3311405	Locknut 1/4"-20NC	5	
18	Not Used			
19	4842227	Door (Right Side)	1	
20	0641406	Bolt 1/4"-20NC x 3/4"	12	
21	4751400	Flatwasher 1/4"	12	
22	3311405	Locknut 1/4"-20NC	12	
23	2940042	Latch	2	
24	0901595	Bracket, Door Latch	2	
25	3311505	Locknut 5/16"-18NC	4	
26	4751500	Flatwasher 5/16"	4	
	4300038	Stud (Welded on Part) (Not Shown)	4	
27	0940036	Bumper, Rubber	4	
28	0901198	Bracket, Door Stop (Located on Left Side & at Bottom of Hydraulic Tank on Right Side)	1	
	0901197	Bracket, Door Stop (Located at Bottom of Fuel Tank)	1	
29	3311505	Locknut 5/16"-18NC	2	
	4751500	Flatwasher 5/16"	2	
	4300038	Stud (Welded on Part) (Not Shown)	2	
30	0641508	Bolt 5/16"-18NC x 1"	2	
	4761500	Lockwasher 5/16"	2	
	4751500	Flatwasher 5/16"	2	
31	4160081	Spring, Gas	2	
32	3311505	Locknut 5/16"-18NC	4	
33	4751500	Flatwasher 5/16"	4	
34	3200222	Bracket, Gas Spring	2	
35	0630383	Bolt, Carriage 5/16"-18NC x 3/4"	2	
36	4751500	Flatwasher 5/16"	2	
37	3311505	Locknut 5/16"-18NC	2	
38	0901500	Bracket, Mounting - Hood (Right Side)	1	
39	Not Used			

SECTION 2 TURNTABLE

FIGURE 2-26. HOODS AND ALARM INSTALLATION (MACHINES WITH 4620044 TURNTABLE)
(CONTINUED)

FIG & ITEM #	PART NUMBER	DESCRIPTION	QTY.	REV.
40	3311605	Locknut 3/8"-16NC	2	
41	4751600	Flatwasher 3/8"	2	
	4300034	Stud (Welded on Part - Not Shown)	2	
42	4843963	Hood, Top and Side - Rear (Right Side)	1	
43	3380378	Hood, Top & Side - Rear (Left Side)	1	
44	0641406	Bolt 1/4"-20NC x 3/4"	6	
45	4751400	Flatwasher 1/4"	6	
46	3311405	Locknut 1/4"-20NC	6	
47	3941405	Screw, Self Tap 1/4"-20NC x 5/8"	4	
48	4761400	Lockwasher 1/4"	4	
49	2940045	Latch	A/R	
50	0901502	Bracket, Mounting	A/R	
51	3311605	Locknut 3/8"-16NC	A/R	
52	4751600	Flatwasher 3/8"	A/R	
	4300034	Stud (Welded on Part - Not Shown)	A/R	
53	1780381	Panel, End	1	
54	3311505	Locknut 5/16"-18NC	4	
55	4751500	Flatwasher 5/16"	4	
	4300034	Stud (Welded on Part - Not Shown)	4	
56	1670516	Cover, Front	1	
57	3311405	Locknut 1/4"-20NC	4	
58	4751400	Flatwasher 1/4"	4	
	4300031	Stud (Welded on Part - Not Shown)	4	
59	3380379	Panel, Hood	1	
60	Not Required			
61	3311605	Locknut 3/8"-16NC	A/R	
62	4751600	Flatwasher 3/8"	A/R	
	4300034	Stud (Welded on Part - Not Shown)	A/R	
	0239867	HOOD INSTALLATION - DEUTZ ENGINE MACHINES	Ref.	A
101	3380377	Panel - Top Hood (Left Side)	1	
102	4843070	Ventilator	2	
103	3380382	Panel - Side (Left Side) (Without Door)	1	
104	4842227	Door (Left Side)	1	
105	4843324	Bracket, Mounting - Hood (Left Side)	1	
106	Not Required			
	0250178	ALARM INSTALLATION	Ref.	B
201	Not Used			
202	0140024	Alarm	1	
203	4300031	Stud (Welded on Part - Not Shown)	2	
204	4751400	Flatwasher 1/4"	2	
205	4761400	Lockwasher 1/4"	2	
206	3311401	Nut 1/4"-20NC	2	

SECTION 2 TURNTABLE

FIGURE 2-26. HOODS AND ALARM INSTALLATION (MACHINES WITH 4620044 TURNTABLE)
(CONTINUED)

FIG & ITEM #	PART NUMBER	DESCRIPTION	QTY.	REV.

SECTION 2 TURNTABLE

FIGURE 2-27. HOODS AND ALARM INSTALLATION (MACHINES WITH 4620078 TURNTABLE)

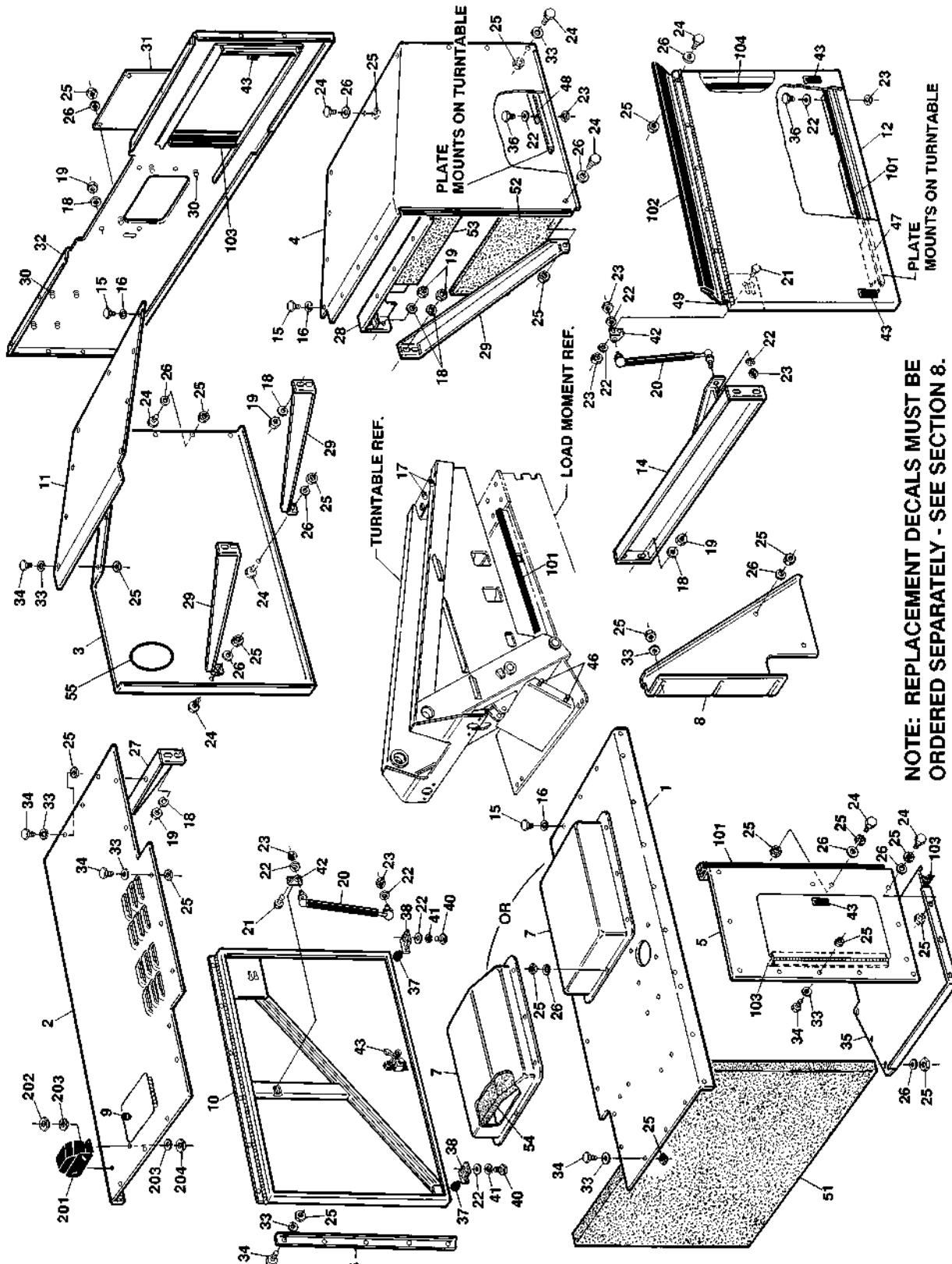

NOTE: REPLACEMENT DECALS MUST BE ORDERED SEPARATELY - SEE SECTION 8.

SECTION 2 TURNTABLE

FIGURE 2-27. HOODS AND ALARM INSTALLATION (MACHINES WITH 4620078 TURNTABLE)

FIG & ITEM #	PART NUMBER	DESCRIPTION	QTY.	REV.
	0253362	HOODS INSTALLATION	Ref.	5
1	3536417	Panel - Hood Top (Engine Side)	1	
2		Panel - Top Hood (Right Side) Options:	1	
	4844114	October 1992 to February 1993		
	4844390	February 1993 to Present		
3		Panel - Hood (Valve Side) Options:	1	
	3380378	Prior to July 1995		
	3380419	July 1995 to Present		
4	3380400	Panel - Hood (Engine Side)	1	
5	4844087	Panel - Door (Engine Side)	1	
6	1780172	Door (Valve Side)	1	
7	4844236	Duct, Discharge (Engine Side)	1	
8	3535948	Plate, Baffle (Engine Side)	1	
9	2940051	Latch	1	
10	4844113	Door (Valve Side)	1	
11	3380379	Panel - Hood Top (Valve Side)	1	
12	4844074	Door (Engine Side)	1	
13	Not Used			
14	4843334	Mounting, Gas Spring	1	
15	3941405	Screw, Self-Tap 1/4" x 5/8"	8	
16	4761400	Lockwasher 1/4"	8	
17	4300034	Stud (Welded on Part)	16	
18	4751600	Flatwasher 3/8"	16	
19	3311605	Locknut 3/8"-16NC	16	
20	4160081	Spring, Gas	2	
21	0630383	Bolt, Carriage 5/16"-18NC x 3/4"	4	
22	4751500	Flatwasher 5/16"	10	
23	3311505	Locknut 5/16"-18NC	6	
24	0641406	Bolt 1/4"-20NC x 3/4"	40	
25	3311405	Locknut 1/4"-20NC	70	
26	4751400	Flatwasher 1/4"	48	
27	0901500	Bracket, Mounting - Hood	1	
28	4843324	Bracket, Mounting - Hood	1	
29	0901502	Bracket, Mounting - Hood	3	
30	Not Used			
31	1670516	Cover, Front	1	
32	4844083	Hood (Front)	1	
33	4740362	Washer, Fender	41	
34	0641408	Bolt 1/4"-20NC x 1"	22	
35	3537819	Plate, Extension - Base	1	
36	0641512	Bolt 5/16"-18NC x 1 1/2"	5	
37	0940036	Bumper, Door	2	
38	0901197	Bracket, Door Stop	2	
39	Not Used			
40	0641508	Bolt 5/16"-18NC x 1"	4	
41	4761500	Lockwasher 5/16"	4	
42	3200222	Mounting, Gas Spring	2	

SECTION 2 TURNTABLE

**FIGURE 2-27. HOODS AND ALARM INSTALLATION (MACHINES WITH 4620078 TURNTABLE)
(CONTINUED)**

FIG & ITEM #	PART NUMBER	DESCRIPTION	QTY.	REV.
43	2940042	Mounting, Latch	5	
44	Not Used			
45	Not Used			
46	4300032	Stud (Welded on Part)	5	
47	3536414	Plate, Seal	1	
48	3536415	Plate, Seal	1	
49	3535951	Plate, Hinge Shield	1	
50	3820018	Rivet	10	
51	2820059	Acoustical Foam - 33 x 20	1	
52	2820058	Acoustical Foam - 20 x 17	1	
53	2820053	Acoustical Foam - 6 3/4" x 14 3/4"	1	
54	2820057	Acoustical Foam - 24" x 16 3/4"	1	
55	4060803	Flex-Trim (July 1995 to Present)	2ft/61cm	
	0100011	----- Loctite #242	A/R	
	0252652	HOOD SEALS INSTALLATION	Ref.	A
101	3960418	Seal	13 ft./4m	
102	3960389	Seal, Door	8 ft./2.4m	
103	3960429	Tape, Sealant	7 ft./2.1m	
104	3960433	Seal	6 ft./1.8m	
	0251543	ALARM INSTALLATION (OPTIONAL)	Ref.	2
201	0140032	Alarm	1	
202	0641406	Bolt 1/4"-20NC x 3/4"	2	
203	4751400	Flatwasher 1/4"	4	
204	3311405	Locknut 1/4"-20NC	2	

SECTION 2 TURNTABLE

SECTION 3 BOOM

TABLE OF CONTENTS		
FIGURE	DESCRIPTION	PAGE
3-1	BOOM ASSEMBLY COMPONENTS	3-2
3-2	CHAIN ADJUSTER ASSEMBLIES	3-14
3-3	EXTEND-A-REACH INSTALLATIONS (Prior to May 1992) (100HX+10 & 110HXER Only)	3-18
3-4	EXTEND-A-REACH INSTALLATIONS (May 1992 to Present) (100HX+10 & 110HXER Only) .	3-22
3-5	BOOM LENGTH INDICATOR AND LIMIT SWITCHES INSTALLATION.	3-24
3-6	BROKEN CHAIN LIMIT SWITCH INSTALLATION (German/Austrian Specs.)	3-28
3-7	BOOM WIPERS INSTALLATION	3-30

SECTION 3 BOOM

FIGURE 3-1. BOOM ASSEMBLY COMPONENTS INSTALLATION (SHEET 2 OF 2)

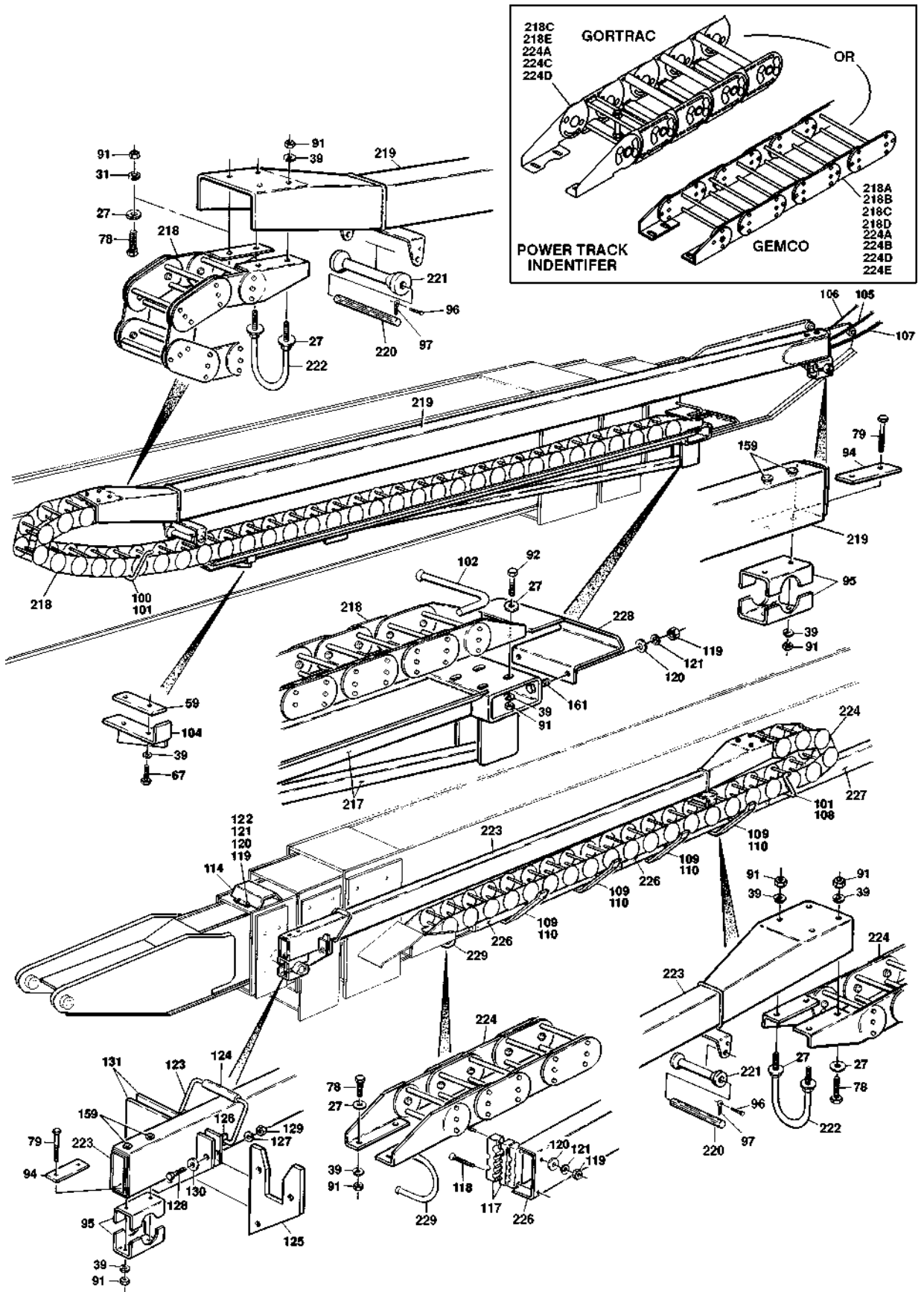

SECTION 3 BOOM

FIGURE 3-1. BOOM ASSEMBLY COMPONENTS INSTALLATION

FIG & ITEM #	PART NUMBER	DESCRIPTION	QTY.	REV.
		BOOM ASSEMBLIES (STANDARD PARTS)	Ref.	
1 to 9	Not Used			
10	3580139	Sheave - Outer Mid Extend Chain	1	
11	0238927	Sheave Assembly - Fly Extend Chain	3	A
	0961293	Bushing, Bronze (1 Per Sheave)	3	
12	0237151	Sheave Assembly - Outer Mid Retract Chain	2	B
	0961353	Bushing, Bronze (1 Per Sheave)	2	
13 to 14	Not Used			
15	3421286	Pin, Attach	4	
16	1360171	Clevis	1	
17	3421279	Pin, Attach	1	
18	3450408	Pin, Cotter 1/8" x 2"	2	
19	3313002	Nut, Jam 1 1/4"-7NC	1	
20	3300244	Locknut, Nylon 1 1/4"-7NC Grade 8	1	
21	3312602	Nut, Jam 1"-8NC	2	
22	3300243	Locknut, Nylon 1"-8NC Grade 8	2	
23	0238901	Adjustable Clevis Assembly - Outer Mid Extend Chain (See Figure 3-2 for Breakdown)	1	
24	Not Used			
25	Not Used			
26	3421570	Pin, Attach	2	
27	4751600	Flatwasher 3/8"	35	
28	3450303	Pin, Cotter 3/22" x 3/4"	10	
29	0238919	Adjustable Clevis Assembly - Fly Extend Chain (See Figure 3-2 for Breakdown)	1	
30	3421280	Pin, Attach	4	
31	4751000	Flatwasher #10	A/R	
32	3450202	Pin, Cotter 1/16" x 1/2"	A/R	
33	Not Used			
34	3420659	Pin, Attach (Mid 1990 to Present)	2	
35	0238945	Adjustable Clevis Assembly - Outer Mid Retract Chain (See Figure 3-2 for Breakdown)	1	
36	Not Used			
37	3300240	Locknut, Nylon 5/8"-11NC (Grade 8)	4	
38	3312002	Nut, Jam 5/8"-11NC	4	
39	4761600	Lockwasher 3/8"	A/R	
40	Not Used			
41	4843105	Mount, End - Chain	1	
42	3421539	Pin, Sheave	1	
43	3450814	Pin, Cotter 1/4" x 3 1/2"	2	
44	4070616	Shim 1/32"/.8mm	A/R	
45	0560689	Block, Mounting - Wear Pad	2	
46	2160002	Fitting, Grease	7	
47	3421538	Pin, Sheave (Prior to Mid 1990)	2	
	3421778	Pin, Sheave (Mid 1990 to Present)	1	
48	4740307	Washer, Thrust	A/R	
49	3421290	Pin, Sheave	2	
50	Not Used			

SECTION 3 BOOM

FIGURE 3-1. BOOM ASSEMBLY COMPONENTS INSTALLATION (CONTINUED)

FIG & ITEM #	PART NUMBER	DESCRIPTION	QTY.	REV.
51	4740311	Washer, Thrust	12	
52	3951606	Setscrew 3/8"-16NC x 3/4"	5	
53	0100011	Loctite #242 (Not Shown)	A/R	
54	3421497	Pin, Trunion	2	
55	3421293	Pin, Cylinder	1	
56	3340475	Pad, Wear (Fly Rear Top, Inner Mid Rear Top and Outer Mid Rear Top)	6	
57	4070535	Shim 1/8"/3.2mm	A/R	
58	4070536	Shim 1/16"/1.6mm	A/R	
59	3340263	Pad, Wear (Carrier Support - Left Side, Fly Rear Sides and Outer Mid Rear Sides)	9	
60	4070544	Shim 1/16"/1.6mm	A/R	
61	4070545	Shim 1/8"/3.2mm	A/R	
62	3340563	Pad, Skid	4	
63	4070615	Shim 1/16"/1.6mm	A/R	
64	1120019	Cap	4	
65	0721003	Bolt #10-24NC x 3/8"	12	
66	4761000	Lockwasher #10	12	
67	0641605	Bolt 3/8"-16NC x 5/8"	2	
68	0641607	Bolt 3/8"-16NC x 7/8"	18	
69	0641609	Bolt 3/8"-16NC x 1 1/8"	52	
70	4761800	Lockwasher 1/2"	1	
71	0641808	Bolt 1/2"-13NC x 1"	1	
72	4751800	Flatwasher 1/2"	2	
73	0641614	Bolt 3/8"-16NC x 1 3/4"	7	
74	0641630	Bolt 3/8"-16NC x 3 3/4"	6	
75	3340496	Pad, Wear (Base Front Bottom)	2	
76	4070602	Shim 1/8"/3.2mm	A/R	
77	4070603	Shim 1/16"/1.6mm	A/R	
78	0641608	Bolt 3/8"-16NC x 1"	8	
79	0641636	Bolt 3/8"-16NC x 4 1/2"	4	
80	0239607	Sheave Assembly	1	
	0961370	Bushing, Bronze (1 Per Sheave)	1	
81	Not Used			
82	3340506	Pad, Wear (Outer Mid Front Bottom)	2	
83	3340500	Pad, Wear (Outer Mid Front Sides and Top, Inner Mid Front Top and Base Front Top)	10	
84	4070708	Shim 1/16"/1.6mm	A/R	
85	4070709	Shim 1/8"/3.2mm	A/R	
86	3340502	Pad, Wear (Inner Mid Front Sides and Base Front Sides)	8	
87	4070710	Shim 1/16"/1.6mm	A/R	
88	4070711	Shim 1/8"/3.2mm	A/R	
89 to 90	Not Used			
91	3311601	Nut 3/8"-16NC	20	
92	0641610	Bolt 3/8"-16NC x 1 1/4"	6	
93	Not Used			
94	4280242	Strip, Reinforcing	2	
95	1320121	Clamp (Prior to S/N 51528)	4	
96	0641404	Bolt 1/4"-20NC x 1/2"	2	

SECTION 3 BOOM

FIGURE 3-1. BOOM ASSEMBLY COMPONENTS INSTALLATION (CONTINUED)

FIG & ITEM #	PART NUMBER	DESCRIPTION	QTY.	REV.
97	3450806	Pin, Cotter 1/4" x 1 1/2"	2	
98 to 99	Not Used			
100	3840956	Hanger (Left Side)	1	
101	2660042	Holder	1	
102		Rod, Hose Retainer (Left Side) Options:	1	
	3840957	Prior to S/N 40625		
	0902470	S/N 40625 to Present		
103	Not Used			
104	4843080	Bracket, Support - Carrier Wear Pad (Left Side)	1	
105		Cable, Electrical - 12/4	131ft./40m	
	Use 1060515	Prior toS/N 52883 (Was P/N1060012)		
	1060515	S/N 52883 to Present		
106	4921168	Harness - 110V (Prior to May 1992)	1	
107		Cable, Electrical - 16/30	131ft./40m	
	Use 1060516	Prior toS/N 52883 (Was P/N1060229)		
	1060516	S/N 52883 to Present		
108	3840844	Hanger (Right Side)	1	
109	4340519	Support	4	
110	0880090	Brace	4	
111 to 113	Not Used			
114	3532793	Plate, Hose Cover	1	
115 to 116	Not Used			
117	4340413	Support, Hydraulic Line	8	
118	4300098	Stud (Welded on Part)	8	
119	3311401	Nut 1/4"-20NC	18	
120	4751400	Flatwasher 1/4"	21	
121	4761400	Lockwasher 1/4"	18	
122	4300032	Stud (Welded on Part)	10	
123	3840858	Rod, Tube Retainer	1	
124	4562516	Tube	1	
125	4340453	Support, Bracket	1	
126	0181175	Angle	2	
127	4761500	Lockwasher 5/16"	3	
128	0641510	Bolt 5/16"-18NC x 1 1/4"	3	
129	3311501	Nut 5/16"-18NC	3	
130	4751500	Flatwasher 5/16"	6	
131	4340520	Support	2	
132	4740349	Washer, Special	1	
133	3421632	Pin	1	
134	Not Used			
135	3421571	Pin, Attach	2	
136	1380124	Clip, Retainer (Prior to October 1995)	34	
137	4920385	Wire, Safety (Prior to October 1995)	17.6'/5.4m	
138	Not Used			
139	3430408	Pin, Clevis 1/4" x 1"	1	
140	3450203	Pin, Cotter 1/16" x 3/4"	1	
141	3421628	Pin	2	
142 to 143	Not Used			
144	4160098	Washer, Belleville	A/R	

SECTION 3 BOOM

FIGURE 3-1. BOOM ASSEMBLY COMPONENTS INSTALLATION (CONTINUED)

FIG & ITEM #	PART NUMBER	DESCRIPTION	QTY.	REV.
145	4712000	Flatwasher	2	
146	0361727	Bar	1	
147	1260261	Chain (Mid 1990 to Present)	1	
148	1360223	Clevis (Mid 1990 to Present)	1	
149	1060016	Cable, Electrical - 16/3 (Not Shown)	80ft/24.4m	
150 to 152	Not Used			
153	3340494	Pad, Wear (Inner Mid Front Bottom)	2	
154	4070600	Shim 1/8"/3.2mm	A/R	
155	4070601	Shim 1/16"/1.6mm	A/R	
156 to 157	Not Used			
158	0741608	Screw, Countersunk 3/8"-16NC x 1"	1	
159	3520029	Plug, Hole	4	
160	4740304	Washer, Spacer	2	
161	0641407	Bolt 1/4"-20NC x 7/8"	2	
162	1670836	Cover, Boom (Located on bottom of boom sections) (Not Shown) (S/N 34323 to Present)	8	
163	0641611	Bolt 3/8"-16NC x 1 3/8" (S/N 40625 to Present)	2	
		BOOM ASSEMBLY (VARIABLE PARTS)	Ref.	
	0800799	100HX Standard Machine with 4620078 Turntable	Ref.	12
	0800801	100HX With Chip Covers & 4620078 Turntable	Ref.	12
	0800648	110HX Standard Machine with 4620044 Turntable Machines Built Prior To Early 1990	Ref.	A
	0800692	110HX Standard Machine with 4620044 Turntable Machines Built Early 1990 To May 1992	Ref.	E
	0800797	110HX Standard Machine with 4620078 Turntable Machines	Ref.	10
	0800897	110HX With Chip Covers & 4620078 Turntable Machines	Ref.	8
	0800597	100HX+10 & 110HXER Standard Machine with 4620044 Turntable Machines Built Prior To Early 1990	Ref.	D
	0800687	100HX+10 & 110HXER Standard Machine with 4620044 Turntable Machines Built Early 1990 To May 1992	Ref.	G
	0800784	100HX+10 & 110HXER Standard Machine with 4620078 Turntable	Ref.	11
	0800782	100HX+10 & 110HXER With Chip Covers & 4620078 Turntable	Ref.	11
201		Base Weldment Options:	1	
	0800802	100HX		
	0800649	110HX		
	0800603	100HX+10 & 110HXER		
202		Inner Mid Weldment Options:	1	
	0800785	100HX		
	0800650	110HX with 4620044 Turntable Machines Built Prior To Early 1990		
	0800694	110HX with 4620044 Turntable Machines Built Early 1990 To May 1992		
	0800766	110HX with 4620078 Turntable Machines		

SECTION 3 BOOM

FIGURE 3-1. BOOM ASSEMBLY COMPONENTS INSTALLATION (CONTINUED)

FIG & ITEM #	PART NUMBER	DESCRIPTION	QTY.	REV.	
202A 203	0800604	100HX+10 & 110HXER with 4620044 Turntable Machines Built Prior To Early 1990			
	0800689	100HX+10 & 110HXER with 4620044 Turntable Machines Built Early 1990 To May 1992			
	0800785	100HX+10 & 110HXER With 4620078 Turntable			
	3532549	Plate, Skid	1		
		Outer Mid Weldment Options:	1		
	0800786	100HX			
	0800651	110HX with 4620044 Turntable Machines Built Prior To Early 1990			
	0800695	110HX with 4620044 Turntable Machines Built Early 1990 To May 1992			
	0800767	110HX with 4620078 Turntable Machines			
	0800605	100HX+10 & 110HXER with 4620044 Turntable Machines Built Prior To Early 1990			
203A	0800690	100HX+10 & 110HXER with 4620044 Turntable Machines Built Early 1990 To May 1992			
	0800786	100HX+10 & 110HXER with 4620078 Turntable Plate, Skid	1		
	3532569	4620044 Turntable Machines			
	3532549	4620078 Turntable Machines			
204		Fly Weldment Options:	1		
	0800804	100HX			
	0800556	110HX with 4620044 Turntable Machines Built Prior To Early 1990			
	0800696	110HX with 4620044 Turntable Machines Built Early 1990 To May 1992			
	0800796	110HX with 4620078 Turntable Machines			
	0800565	100HX+10 & 110HXER with 4620044 Turntable Machines Built Prior To Early 1990			
	0800691	100HX+10 & 110HXER with 4620044 Turntable Machines Built Early 1990 To May 1992			
	0800787	100HX+10 & 110HXER with 4620078 Turntable			
	205		Telescope Cylinder Assembly Options (See Section 5 for Breakdown)	1	
		1682032	100HX Prior to October 1992		
1682821		100HX October 1992 to Present			
1682030		110HX Prior to October 1992			
1682820		110HX October 1992 to Present			
1682032		100HX+10 & 110HXER Prior to October 1992			
1682821		100HX+10 & 110HXER October 1992 to Present			
206			Chain, Extend - Outer Mid Options (BL866):	1 set	
		1260239	100HX		
		1260235	110HX		
207	1260239	100HX+10 & 110HXER			
		Chain, Extend - Fly Options (BL823):	1 set		
	1260238	100HX			
	1260234	110HX			
	1260238	100HX+10 & 110HXER			

SECTION 3 BOOM

FIGURE 3-1. BOOM ASSEMBLY COMPONENTS INSTALLATION (CONTINUED)

FIG & ITEM #	PART NUMBER	DESCRIPTION	QTY.	REV.	
208		Chain, Retract - Fly Options:	1		
	1260282	100HX			
	1260232	110HX 4620044 Turntable (BL423)			
	1260275	110HX with 4620078 Turntable (BL446)			
	1260236	100HX+10 & 110HXER with 4620044 Turntable (BL423)			
	1260282	100HX+10 & 110HXER with 4620078 Turntable (BL446)			
209		Chain, Retract - Outer Mid Options (BL446):	1		
	1260237	100HX			
	1260233	110HX			
	1260237	100HX+10 & 110HXER			
210		Sheave Assembly - Fly Retract Chain Options: 4620038 & 4620044 Turntable Machines:			
	0232901	Sheave Assembly - Fly Retract Chain			2
	0440074	Bearing, Roller (1 Per Sheave)			2
	3960206	Seal (2 Per Sheave)			4
		4620078 Turntable Machines:			
	0239606	Sheave Assembly - Fly Retract Chain			2
	0961369	Bushing, Bronze (1 Per Sheave)			2
211		Adjustable Clevis Assembly - Outer Mid Extend Chain Options (See Figure 3-2 for Breakdown):	1		
	0239267	100HX			
	0239268	110HX			
	0239267	100HX+10 & 110HXER			
212		Pin, Attach Options:	2		
	3421216	4620044 Turntable Machines			
	3421629	4620078 Turntable Machines			
213		Pin, Attach Options:	2		
	3420659	4620044 Turntable Machines			
	3421280	4620078 Turntable Machines			
214		Adjustable Clevis Assembly - Fly Retract Chain Options (See Figure 3-2 for Breakdown):	1		
	0238946	4620044 Turntable Machines (BL423 Chain)			
	0238945	4620078 Turntable Machines (BL446 Chain)			
215		Pin, Sheave Options:	2		
	3421289	4620044 Turntable Machines			
	3422040	4620078 Turntable Machines			
216		Bracket, Wear Pad Options:	1		
	0901503	4620044 Turntable Machines			
	0901700	4620078 Turntable Machines			
217		Tube, Hose and Cable (Left Side) Options:	1		
	4843103	4620044 Turntable Machines			
	4844126	4620078 Turntable Machines			
218		Carrier (Left Side) Options:	1		
218A		Power Track for 4620044 Turntable Machines:			
	1180187	110HX with 4620044 Turntable			
	1180188	100HX+10 & 110HXER with 4620044 Turntable			

SECTION 3 BOOM

FIGURE 3-1. BOOM ASSEMBLY COMPONENTS INSTALLATION (CONTINUED)

FIG & ITEM #	PART NUMBER	DESCRIPTION	QTY.	REV.
218B		Power Track Replacement Parts (4620044 Turntable Machines):		
	7006178 Use 7006143	Repair Section - 1 Foot Bracket, Mounting (Includes 1 left, 1 right mounting brackets & 2 spacers) (was p/n 7006179)	A/R 4	
	Use 7006138	Pin Assembly (Includes 1 link pin, 1 retaining ring & 4 washers of various thicknesses) (was p/n 7006180)	A/R	
218C		Power Track 4620078 Turntable Machines :		
	1180286	100HX without Chip Covers & 4620078 Turntable (was p/n 1180286 - Gemco is Original Equipment/Gortrac is Service Replacement)		
	1180295	100HX, 100HX+10 & 110HXER with Chip Covers & 4620078 Turntable		
	1180288	110HX without Chip Covers & 4620078 Turntable		
	1180296 1180292	110HX with Chip Covers & 4620078 Turntable 100HX+10 & 110HXER with 4620078 Turntable		
218D		Gemco Power Track Replacement Parts (4620078 Turntable Machines):		
	7006193	Repair Section - 1 Foot without Chip Covers (100HX, 100HX+10 & 110HXER)	A/R	
	7006514	Repair Section - 1 Foot without Chip Covers (110HX)	A/R	
	7006178	Repair Section - 1 Footwith Chip Covers (100HX)	A/R	
	7006145	Repair Section - 1 Footwith Chip Covers (100HX+10 & 110HXER)	A/R	
	7006196	Repair Section - 1 Footwith Chip Covers (110HX)	A/R	
	7006143	Bracket, Mounting (Includes 1 left, 1 right mounting brackets & 2 spacers)	4	
	7006138	Pin Assembly (Includes 1 link pin, 1 retaining ring & 4 washers of various thicknesses)	A/R	
	7016520	Rod W/Roll Pin (1180286 Power Track Only)	1	
	7016531	Clamping Carrier Assembly (Includes 2 link pins, 1 clamping carrier, 1 clamping stiffener, 1 bolt, 1 nut & 1 lockwasher) (1180286 Power Track Only)	1	
	7006165	Kit, Rod Carrier (Includes 1 rod, 1 sleeve & 2 screws) (1180286 Power Track Only)	1	
218E		Gortrac Power Track Replacement Parts (4620078 Turntable Machines):		
	70003143	Repair Section (Includes 1 set of attaching hardware) (1001119696 Power Track Only)	A/R	
	70003144	Mounting Bracket Kit (Includes 4 mtg feet & hardware to attach to track) (1001119696 Power Track Only)	A/R	

SECTION 3 BOOM

FIGURE 3-1. BOOM ASSEMBLY COMPONENTS INSTALLATION (CONTINUED)

FIG & ITEM #	PART NUMBER	DESCRIPTION	QTY.	REV.
219		Carrier Tube Weldment (Left Side) Options:	1	
	1180297	100HX		
	1180185	110HX with 4620044 Turntable		
	1180297	110HX with 4620078 Turntable		
	1180186	100HX+10 & 110HXER with 4620044 Turntable		
220	1180293	100HX+10 & 110HXER with 4620078 Turntable	2	
		Rod, Roller Options:		
221	3840831	4620044 Turntable Machines	2	
	3841013	4620078 Turntable Machines		
222		Roller Options:	2	
	3860046	4620044 Turntable Machines		
223	3860050	4620078 Turntable Machines	2	
		Clamp, U-Bolt Options:		
224	1320072	4620044 Turntable Machines	1	
	1320155	4620078 Turntable Machines		
224A		Carrier Tube Weldment (Right Side) Options:	1	
	1180189	4620044 Turntable Machines		
224B	1180254	4620078 Turntable Machines	1	
		Carrier (Right Side) Options:		
224C		Power Track 4620044 Turntable Machines:	1	
	Use 1001119693	Machines with 4620044 Turntable (was p/n 1180106 - Gemco is Original Equipment/Gortrac is Service Replacement)		
224D		Gemco Power Track Replacement Parts (4620044 Turntable Machines):	A/R	
	7006178	Repair Section - 1 Foot		
224E	Use 7006143	Bracket, Mounting (Includes 1 left, 1 right mounting brackets & 2 spacers) (was p/n 7006179)	4	
	Use 7006138	Pin Assembly (Includes 1 link pin, 1 retaining ring & 4 washers of various thicknesses) (was p/n 7006180)		
224F		Gortrac Power Track Replacement Parts (4620044 Turntable Machines):	A/R	
	70003149	Repair Section (Includes 1 set of attaching hardware) (1001119693 Power Track Only)		
224G	70003150	Mounting Bracket Kit (Includes 4 mtg feet & hardware to attach to track) (1001119693 Power Track Only)	A/R	
		Power Track 4620078 Turntable Machines :		
224H	1180236	Machines without Chip Covers & 4620078 Turntable	1	
	1180258	Machines with Chip Covers & 4620078 Turntable		
224I		Gemco Power Track Replacement Parts (4620078 Turntable Machines):	A/R	
	7006153	Repair Section - 1 Foot without Chip Covers		
224J	7006145	Repair Section - 1 Foot with Chip Covers	4	
	Use 7006143	Bracket, Mounting (Includes 1 left, 1 right mounting brackets & 2 spacers) (was p/n 7006179)		

SECTION 3 BOOM

FIGURE 3-1. BOOM ASSEMBLY COMPONENTS INSTALLATION (CONTINUED)

FIG & ITEM #	PART NUMBER	DESCRIPTION	QTY.	REV.
224E cont'd	Use 7006138	Pin Assembly (Includes 1 link pin, 1 retaining ring & 4 washers of various thicknesses) (was p/n 7006180)	A/R	
	7016520	Rod W/Roll Pin (1180236 Power Track Only)	1	
	7016531	Clamping Carrier Assembly (Includes 2 link pins, 1 clamping carrier, 1 clamping stiffener, 1 bolt, 1 nut & 1 lockwasher) (1180236 Power Track Only)	1	
	7006165	Kit, Rod Carrier (Includes 1 rod, 1 sleeve & 2 screws) (1180236 Power Track Only)	1	
225		Cover, Boom End Options:	1	
	4843087	4620044 Turntable Machines		
	4843107	4620078 Turntable Machines		
226		Shield, Hose and Cable (Right Side) Options:	2	
	4060568	100HX & 110HX with 4620038 & 4620044 Turntable		
	4060685	100HX+10 & 110HXER with 4620038 & 4620044 Turntable		
	4060685	4620078 Turntable Machines		
227		Shield, Hose and Cable (Right Side) Options:	1	
	4060673	100HX & 110HX with 4620038 & 4620044 Turntable		
	4060684	100HX+10 & 110HXER with 4620038 & 4620044 Turntable		
	4060684	4620078 Turntable Machines		
228		Plate, Ramp (Left Side) Options:	1	
	3532841	4620038 & 4620044 Turntable Machines		
	3536001	4620078 Turntable Machines		
229		Rod, Hose Retainer (Right Side) Options:	A/R	
	Not Required	100HX, 100HX+10 & 110HXER	0	
	3840975	110HX with 4620038 & 4620044 Turntable	1	
	Not Required	110HX with 4620078 Turntable	0	
230		Cover Options:	A/R	
	Not Required	4620038 & 4620044 Turntable Machines	0	
	1670321	4620078 Turntable Machines	1	
231		Shim Options:	A/R	
	4070498	4620038 & 4620044 Turntable Machines	A/R	
	Not Required	4620078 Turntable Machines	0	
232		Chain Options:	1	
	1260254	100HX		
	1260242	110HX Built Prior To Early 1990		
	1260254	110HX Built Early 1990 To Present		
	1260242	100HX+10 & 110HXER Built Prior To Early 1990		
	1260254	100HX+10 & 110HXER Built Early 1990 To Present		
233		Clevis Options:	1	
	1360218	110HX Built Prior To Early 1990		
	1360234	110HX Built Early 1990 To Present		

SECTION 3 BOOM

FIGURE 3-1. BOOM ASSEMBLY COMPONENTS INSTALLATION (CONTINUED)

FIG & ITEM #	PART NUMBER	DESCRIPTION	QTY.	REV.
		RADIUS LIMIT TAPE INSTALLATIONS	Ref.	
	0258596	100HX	Ref.	1
	0251098	110HX (4620044 and 4620078 T/T Machines Built Prior to February 1993)	Ref.	A/G
	0252764	110HX (4620078 T/T Machines Built February 1993 to Present)	Ref.	3/C
	0251100	100HX+10/110HXER (4620044 and 4620078 T/T Machines Built Prior to February 1993)	Ref.	4/F
	0251100	100HX+10/110HXER (4620078 T/T Machines Built February 1993 to Present)	Ref.	4/C
301	4420016	Tape - Yellow	A/R	
	4420018	Tape - Blue	A/R	
302	4420017	Tape - Red	A/R	
303	4420015	Tape - White	A/R	

SECTION 3 BOOM

FIGURE 3-2. CHAIN ADJUSTER ASSEMBLIES

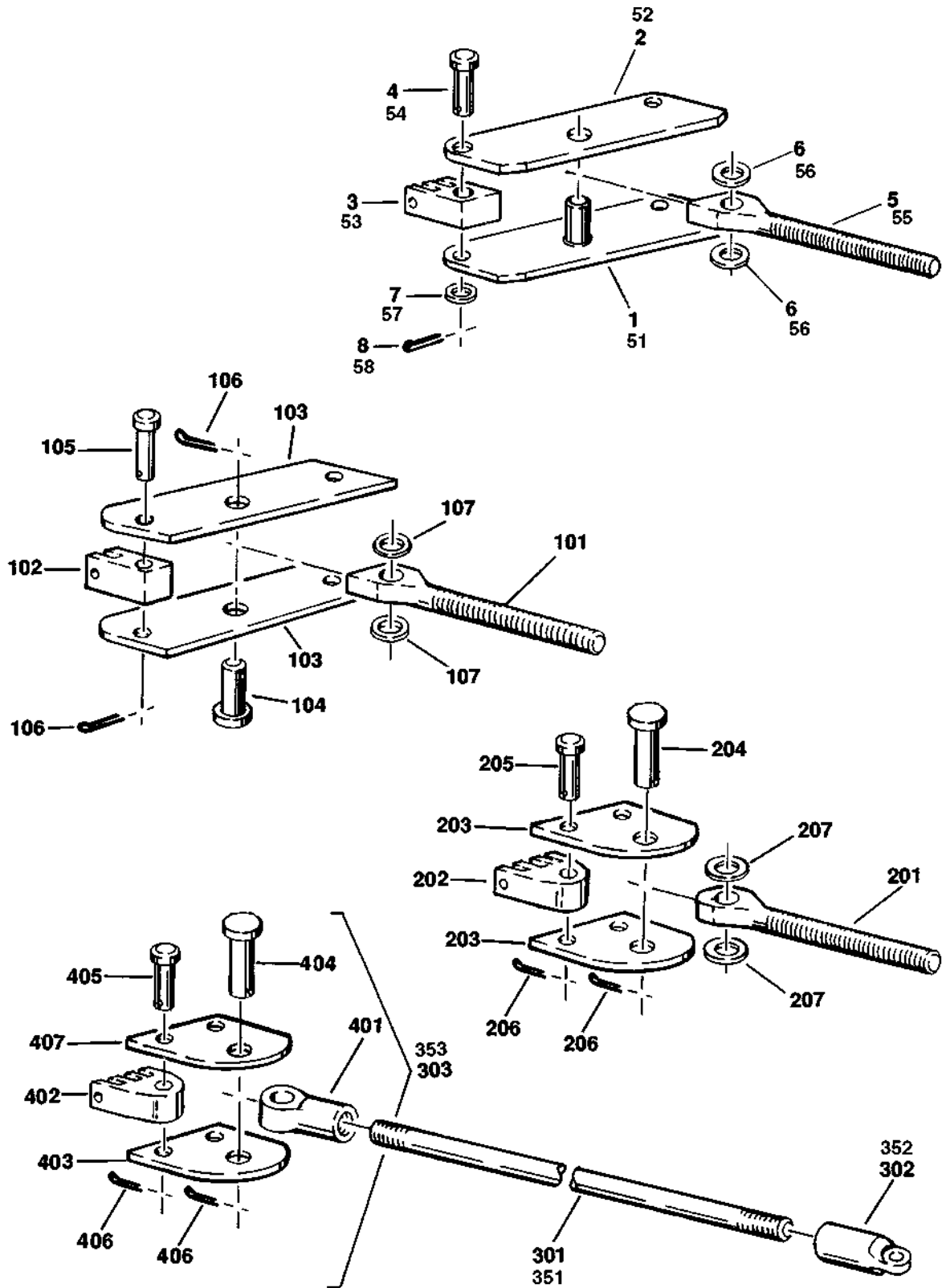

SECTION 3 BOOM

SECTION 3 BOOM

FIGURE 3-2. CHAIN ADJUSTER ASSEMBLIES

FIG & ITEM #	PART NUMBER	DESCRIPTION	QTY.	REV.
	0238946	CHAIN ADJUSTER ASSEMBLY (FLY RETRACT - PRIOR MAY 1992)	Ref.	—
1	4843025	Chain Plate Weldment	1	
2	3532458	Plate, Top	1	
3	0560324	Clevis	2	
4	3420552	Pin, Clevis	2	
5	0630197	Eyebolt	1	
6	4740156	Washer, Thrust	2	
7	4740270	Washer, Special	2	
8	3450504	Pin, Cotter 5/32" x 1"	2	
	0238945	CHAIN ADJUSTER ASSEMBLY (FLY RETRACT - MAY1992 TO PRESENT)	Ref.	—
	0238945	CHAIN ADJUSTER ASSEMBLY (OUTER MID RETRACT)	Ref.	—
51	4843026	Chain Plate Weldment	1	
52	3532466	Plate, Top	1	
53	1360175	Clevis	2	
54	3420552	Pin, Clevis	2	
55	0630197	Eyebolt	1	
56	4740156	Washer, Thrust	2	
57	4740270	Washer, Special	2	
58	3450504	Pin, Cotter 5/32" x 1"	2	
	0238919	CHAIN ADJUSTER ASSEMBLY (FLY EXTEND) EXTEND)	Ref.	—
101	0630410	Eyebolt	1	
102	1360209	Clevis	2	
103	3532425	Plate	2	
104	3421535	Pin, Adjuster Plate	1	
105	3421534	Pin, Clevis	2	
106	3450506	Pin, Cotter 3/32" x 1 1/2"	3	
107	4740111	Washer, Thrust	2	
	0238901	CHAIN ADJUSTER ASSEMBLY (OUTER MID EXTEND)	Ref.	—
201	0630409	Eyebolt	1	
202	1360206	Clevis	2	
203	3532410	Plate	2	
204	3421535	Pin, Adjuster Plate	1	
205	3421534	Pin, Clevis	2	
206	3450506	Pin, Cotter 3/32" x 1 1/2"	3	
207	4740111	Washer, Thrust	2	

SECTION 3 BOOM

SECTION 3 BOOM

FIGURE 3-2. CHAIN ADJUSTER ASSEMBLIES (CONTINUED)

FIG & ITEM #	PART NUMBER	DESCRIPTION	QTY.	REV.
	0239267	CHAIN ADJUSTER AND ROD ASSEMBLY - 100HX, 100HX+10 AND 110HXER (OUTER MID EXTEND)	Ref.	B
301	3840955	Rod	1	
302	1360208	Clevis, Rod	1	
303	0238900	Chain Adjuster Assembly (See Items 401-407 for Breakdown)	1	
304	0100003	Loctite #277 (Not Shown)	A/R	
	0239268	CHAIN ADJUSTER AND ROD ASSEMBLY - 110HX (OUTER MID EXTEND)	Ref.	B
351	3840945	Rod	1	
352	1360208	Clevis, Rod	1	
353	0238900	Chain Adjuster Assembly (See Items 401-407 for Breakdown)	1	
354	0100003	Loctite #277 (Not Shown)	A/R	
	0238900	CHAIN ADJUSTER ASSEMBLY (OUTER MID RETRACT)	Ref.	B
401	1360207	Clevis, Rod	1	
402	1360206	Clevis, Chain	2	
403	3532410	Plate, Chain Adjuster (Top)	1	
404	3421535	Pin, Adjuster Plate	1	
405	3421534	Pin, Clevis	2	
406	3450506	Pin, Cotter 3/32" x 1 1/2"	3	
407	3534436	Plate, Chain Adjuster Plate (Bottom)	1	

SECTION 3 BOOM

FIGURE 3-2. CHAIN ADJUSTER ASSEMBLIES (CONTINUED)

FIG & ITEM #	PART NUMBER	DESCRIPTION	QTY.	REV.

SECTION 3 BOOM

FIGURE 3-3. EXTEND-A-REACH INSTALLATIONS (PRIOR TO MAY 1992)
(100HX+10 & 110HXER ONLY)

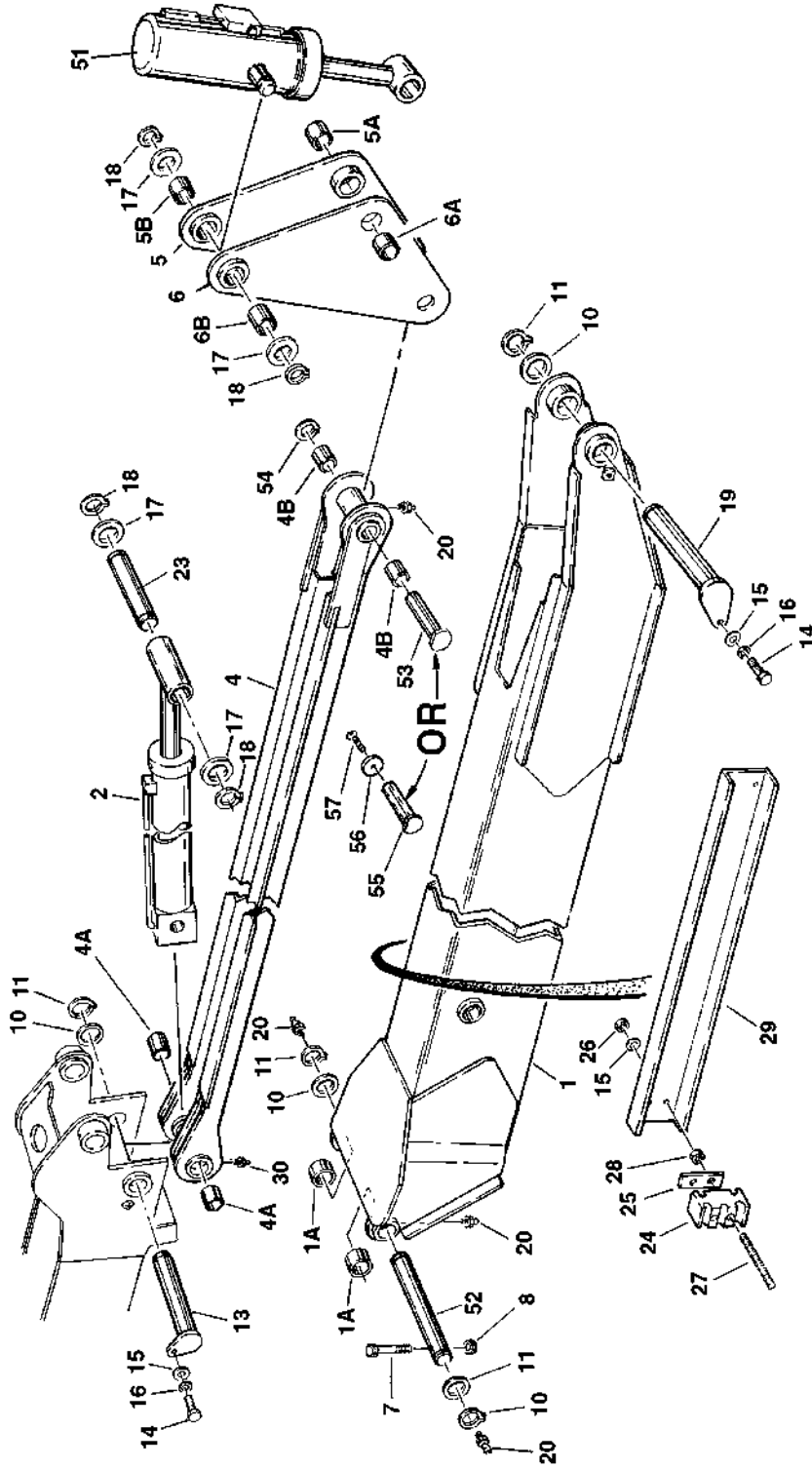

SECTION 3 BOOM

FIGURE 3-3. EXTEND-A-REACH INSTALLATIONS (PRIOR TO MAY 1992) (100HX+10 & 110HXER ONLY)

FIG & ITEM #	PART NUMBER	DESCRIPTION	QTY.	REV.
		EXTEND-A-REACH INSTALLATIONS		
	0239040	Prior To February 1991	Ref.	C
	0251633	February 1991 To May 1992	Ref.	B
1	4843058	Boom, Jib	1	
1A	0961185	Bushing, Oilite	2	
2	1681955	Extend-A-Reach Lift Cylinder Assembly (See Section 5 for Breakdown)	1	
3	Not Used			
4	4843059	Link	1	
4A	0961313	Bushing, Oilite	2	
4B	0961098	Bushing, Oilite	2	
5	4843061	Pivot, Link (Right Side)	1	
5A	0961200	Bushing, Oilite	1	
5B	0961201	Bushing, Oilite	1	
6	4843060	Pivot, Link (Left Side)	1	
6A	0961200	Bushing, Oilite	1	
6B	0961201	Bushing, Oilite	1	
7	0641624	Bolt 3/8"-16NC x 3"	1	
8	3311605	Locknut 3/8"-16NC	1	
9	0100011	Loctite #242 (Not Shown)	A/R	
10	4740332	Washer, Hardened	4	
11	3760233	Ring, Retaining	4	
12	Not Used			
13	3421567	Pin	1	
14	0641606	Bolt 3/8"-16NC x 3/4"	2	
15	4751600	Flatwasher 3/8"	6	
16	4761600	Lockwasher 3/8"	2	
17	4740333	Washer, Hardened	4	
18	3760237	Ring, Retaining	4	
19	3421513	Pin	1	
20	2160002	Fitting, Grease	4	
21	Not Used			
22	Not Used			
23	3421376	Pin	1	
24	1320145	Clamp	2	
25	0361524	Bar	2	
26	3311605	Locknut 3/8"-16NC	4	
27	4300076	Stud (Welded on Part)	4	
28	3311602	Nut, Jam 3/8"-16NC	4	
29	1670477	Cover, Hose	1	
30	2160006	Fitting, Grease	2	
31 to 50	Not Used			
51		Extend-A-Reach Platform Level Cylinder Assembly Options (See Section 5 for Breakdown):	1	
	1681791	Prior To February 1991		
	1682459	February 1991 To May 1992		

SECTION 3 BOOM

FIGURE 3-3. EXTEND-A-REACH INSTALLATIONS (PRIOR TO MAY 1992) (100HX+10 & 110HXER ONLY) (CONTINUED)

FIG & ITEM #	PART NUMBER	DESCRIPTION	QTY.	REV.
52	3421568	Pin Options: Prior To February 1991	1	
	3841822	February 1991 To May 1992		
53	3421429	Pin Options: Prior To February 1991	A/R	
	Not Required	February 1991 To May 1992	0	
54	3760133	Ring, Retaining Options: Prior To February 1991	A/R	
	Not Required	February 1991 To May 1992	0	
55	Not Required	Pin Options: Prior To February 1991	A/R	
	3421827	February 1991 To July 1991	0	
	3421950	July 1991 to May 1992	1	
56	Not Required	Washer, Hardened Options: Prior To February 1991	A/R	
	4740385	February 1991 To July 1991	0	
	4740390	July 1991 to May 1992	1	
57	3900158	Screw, Countersunk 1/2"-13NC x 3/4"	1	
	0741606	Screw, Countersunk 3/8"-16NC x 3/4"	1	

SECTION 3 BOOM

SECTION 3 BOOM

FIGURE 3-3. EXTEND-A-REACH INSTALLATIONS (PRIOR TO MAY 1992) (100HX+10 & 110HXER ONLY) (CONTINUED)

FIG & ITEM #	PART NUMBER	DESCRIPTION	QTY.	REV.

SECTION 3 BOOM

FIGURE 3-4. EXTEND-A-REACH INSTALLATIONS (MAY 1992 TO PRESENT)
(100HX+10 & 110HXER ONLY)

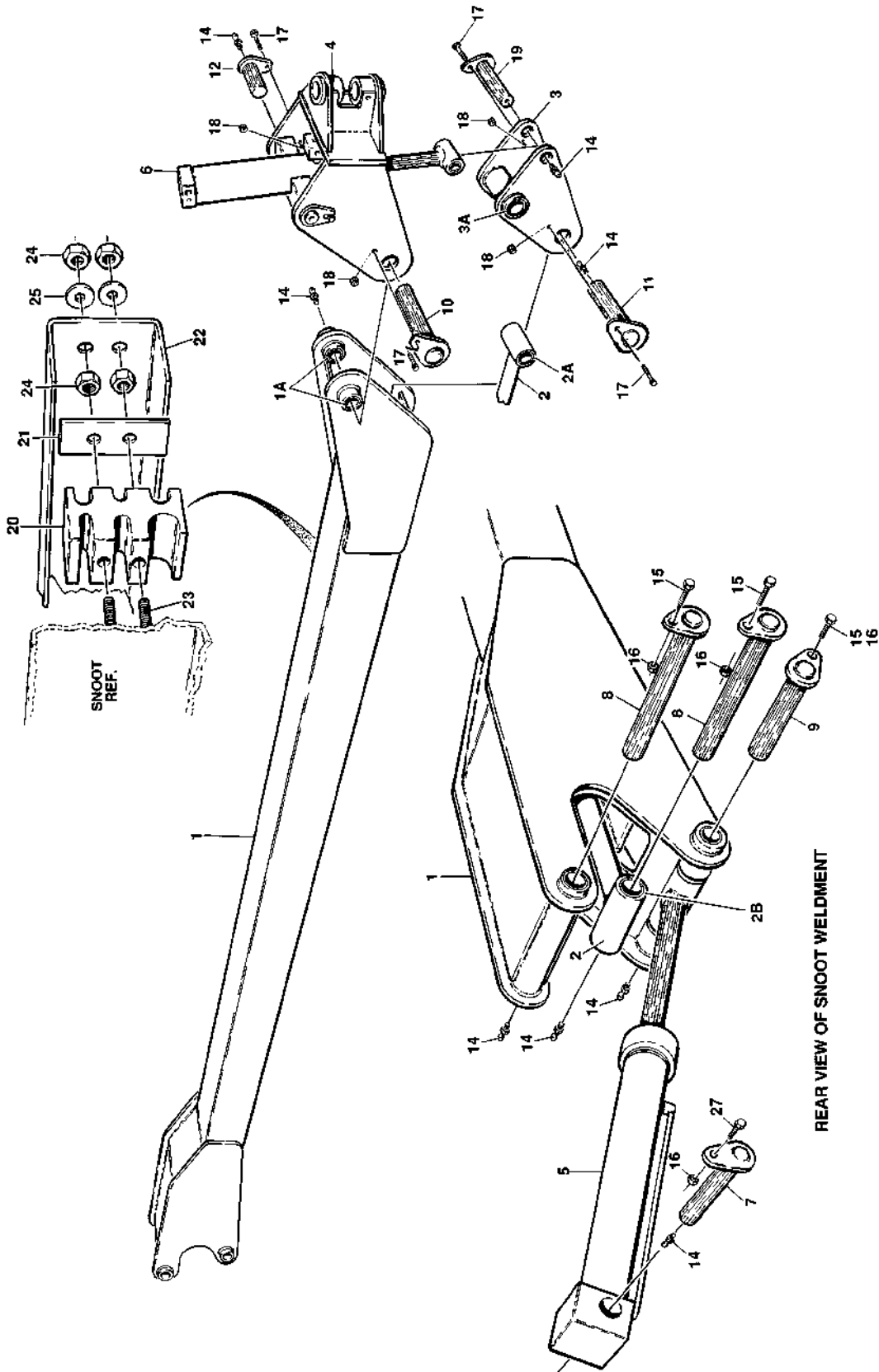

SECTION 3 BOOM

FIGURE 3-4. EXTEND-A-REACH INSTALLATIONS (MAY 1992 TO PRESENT) (100HX+10 & 110HXER ONLY)

FIG & ITEM #	PART NUMBER	DESCRIPTION	QTY.	REV.
	0252858	EXTEND-A-REACH INSTALLATION	Ref.	5
1	4844166	Snoot Weldment (Standard)	1	
1A	0960565	Bushing, Bronze	4	
2	4844167	Level Link Weldment	1	
2A	0961654	Bushing, Bronze (Platform End)	2	
2B	0960565	Bushing, Bronze (Boom End)	2	
3	4844094	Level Plate Weldment	1	
3A	0961654	Bushing, Bronze	2	
4	4844095	Pivot Attach Weldment	1	
	1320051	Clamp, Hose	1	
5		Extend-A-Reach Lift Cylinder Assembly Options: (See Section 5 for Breakdown)	1	
	1682635	Prior to S/N 49403	1	
	1683725	S/N 49403 to Present	1	
6	1682753	Extend-A-Reach Platform Level Cylinder Assembly (May 1992 to S/N 29913)	1	
	1683493	Extend-A-Reach Platform Level Cylinder Assembly (S/N 29913 to Present) (See Section 5 for Breakdown)	1	
7	3422062	Pin, Attach (Lift Cylinder - Barrel End)	1	
8	3422077	Pin, Attach (Snoot and Level Link to Jib)	2	
9	3422079	Pin, Attach (Lift Cylinder - Rod End)	1	
10	3422081	Pin, Attach (Snoot to Pivot)	1	
11	3422083	Pin, Attach (Level Link to Level Plate)	1	
12	3422037	Pin, Attach (Level Cylinder - Barrel End)	2	
13	Not Used			
14	2160002	Fitting, Grease	9	
15	0641608	Bolt 3/8"-16NC x 1"	2	
16	4761600	Lockwasher 3/8"	3	
17	0641610	Bolt 3/8"-16NC x 1 1/4"	6	
18	3311605	Locknut 3/8"-16NC	10	
19	3422085	Pin, Attach (Level Cylinder - Rod End)	1	
20	1320184	Clamp, Hose and Cable	2	
21	3535978	Plate	2	
22	1670642	Cover, Hose and Cable	1	
23	4300076	Stud (Welded on Part)	4	
24	3311602	Nut, Jam 3/8"-16NC	4	
25	4751600	Flatwasher 3/8"	4	
26	0100011	Loctite #242 (Not Shown)	A/R	
27	0641606	Bolt 3/8"-16NC x 3/4"	1	
28	4060803	Trim, Flexible (Not Shown - Located on Front on Boom)	10in/25m	

SECTION 3 BOOM

FIGURE 3-5. BOOM LENGTH INDICATOR AND LIMIT SWITCHES INSTALLATION

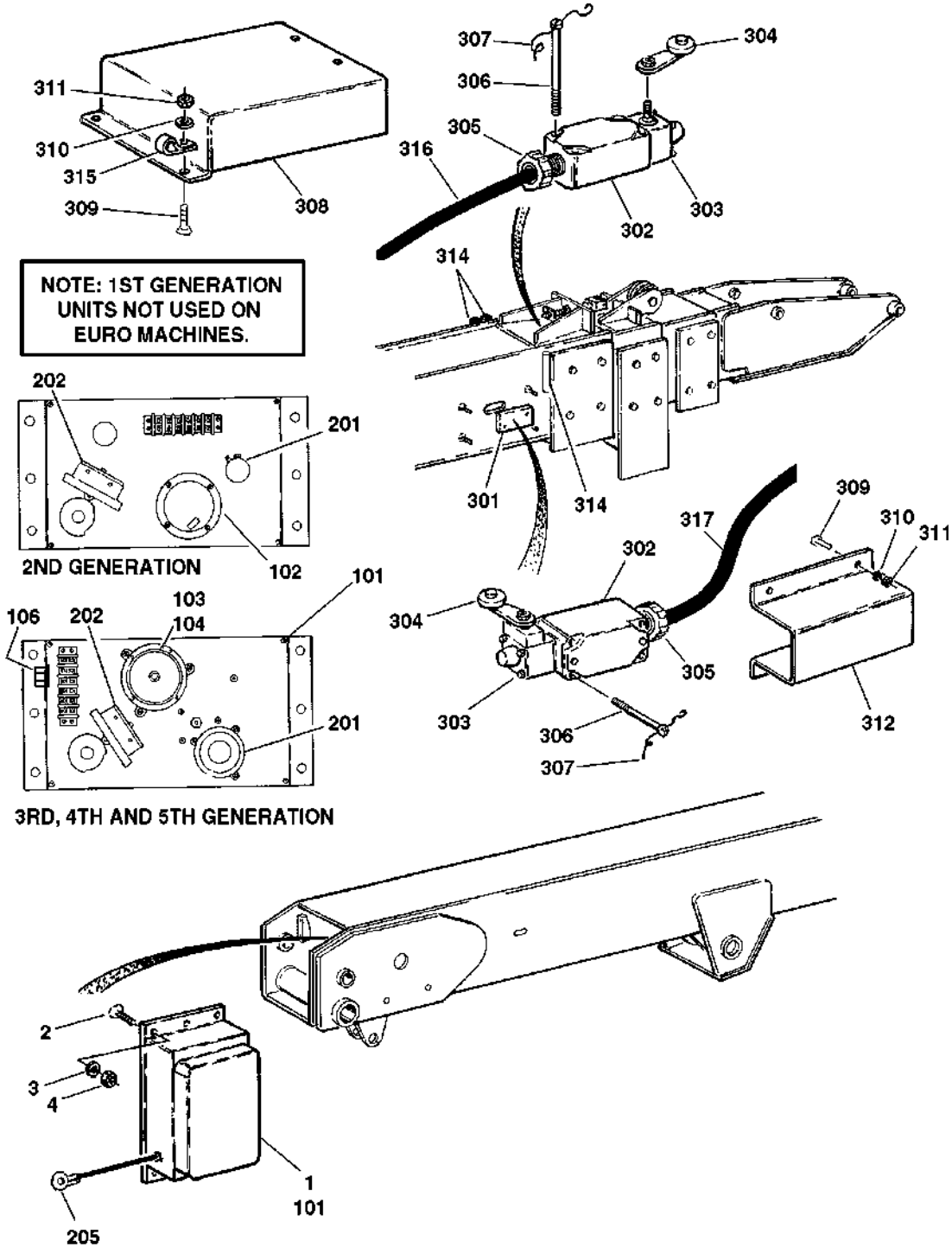

SECTION 3 BOOM

FIGURE 3-5. BOOM LENGTH INDICATOR AND LIMIT SWITCHES INSTALLATION

FIG & ITEM #	PART NUMBER	DESCRIPTION	QTY.	REV.
	0250119	BOOM LENGTH/INDICATOR INSTALLATION	Ref.	2
1	0239485	Boom Length Indicator Assembly (See Item 101-104 for Breakdown)	1	
2	4300032	Stud (Welded on Part)	4	
3	4761400	Lockwasher 1/4"	4	
4	3311401	Nut 1/4"-20NC	4	
	0239485	BOOM LENGTH INDICATOR SUBASSEMBLY	Ref.	D
101	0860575	Indicator Box Assembly (See Items 201-207 for Breakdown)	1	
102	4360153	Pendulum	1	
103	3910408	Screw #4NC x 1/2"	4	
104	4770400	Starwasher #4	4	
105	Not Used			
106	4460428	Connector, Strain Relief	1	
107	3730024	Resistor - 100 Ohms (Not Shown)	1	
	0860575	INDICATOR BOX ASSEMBLY	Ref.	E
201	7000637	Potentiometer	1	
202	7000638	Switch	1	
203	7000639	Spring, Reel (Not Shown)	1	
204	7012526	Spring, Extension (Not Shown)	1	
205	7000647	Cable	1	
206	7016515	Pulley, Nylon (Not Shown)	1	
		BOOM LIMIT SWITCHES INSTALLATION	Ref.	
	0251020	Euro Spec	Ref.	7/H
	0251020	Australian Spec Prior To July 1995	Ref.	7/H
	0255815	Australian Spec July 1995 To Present	Ref.	3
301	3534395	Plate, Mounting	1	
302	4360277	Switch, Limit Options: Euro Spec Australian Spec Prior To July 1995 Australian Spec July 1995 To Present	A/R 2 2 1	
303	4360236	Head, Switch Options: Euro Spec Australian Spec Prior To July 1995 Australian Spec July 1995 To Present	A/R 2 2 1	
304	4360278	Arm, Actuator Options: Euro Spec Australian Spec Prior To July 1995 Australian Spec July 1995 To Present	A/R 2 2 1	

SECTION 3 BOOM

SECTION 3 BOOM

FIGURE 3-5. BOOM LENGTH INDICATOR AND LIMIT SWITCHES INSTALLATION (CONTINUED)

FIG & ITEM #	PART NUMBER	DESCRIPTION	QTY.	REV.
305	4460052	Connector, Strain Relief Options:	A/R	
		Euro Spec	2	
		Australian Spec Prior To July 1995	2	
		Australian Spec July 1995 To Present	1	
306	3900168	Screw, Fillister	A/R	
307	4920140	Wire, Safety	A/R	
308	3533183	Cover Options:	A/R	
		Euro Spec	1	
		Australian Spec Prior To July 1995	1	
		Not Required Australian Spec July 1995 To Present	0	
309	4300031	Stud (Welded on Part)	A/R	
310	4761400	Lockwasher 1/4"	A/R	
311	3311401	Nut 1/4"-20NC	A/R	
312	1670579	Cover	1	
313	Not Used			
314	4564880	Tube options:	A/R	
		Euro Spec	3	
		Australian Spec Prior To July 1995	3	
		Not Required Australian Spec July 1995 To Present	2	
315	1320040	Clamp, Cable	2	
316	1060016	Cable, Electrical - 16/3	A/R	
		Euro Spec	50ft/15.25m	
		Australian Spec Prior To July 1995	50ft/15.25m	
		Not Required Australian Spec July 1995 To Present	0	
317	1060079	Cable, Electrical - 16/4	52ft/15.85m	
318	1670836	Cover, Boom (Not Shown) (S/N 34323 to Present)	2	

SECTION 3 BOOM

FIGURE 3-5. BOOM LENGTH INDICATOR AND LIMIT SWITCHES INSTALLATION (CONTINUED)

FIG & ITEM #	PART NUMBER	DESCRIPTION	QTY.	REV.

SECTION 3 BOOM

FIGURE 3-6. BROKEN CHAIN LIMIT SWITCH INSTALLATION (GERMAN/AUSTRIAN SPECS BUILT PRIOR TO S/N 28224)

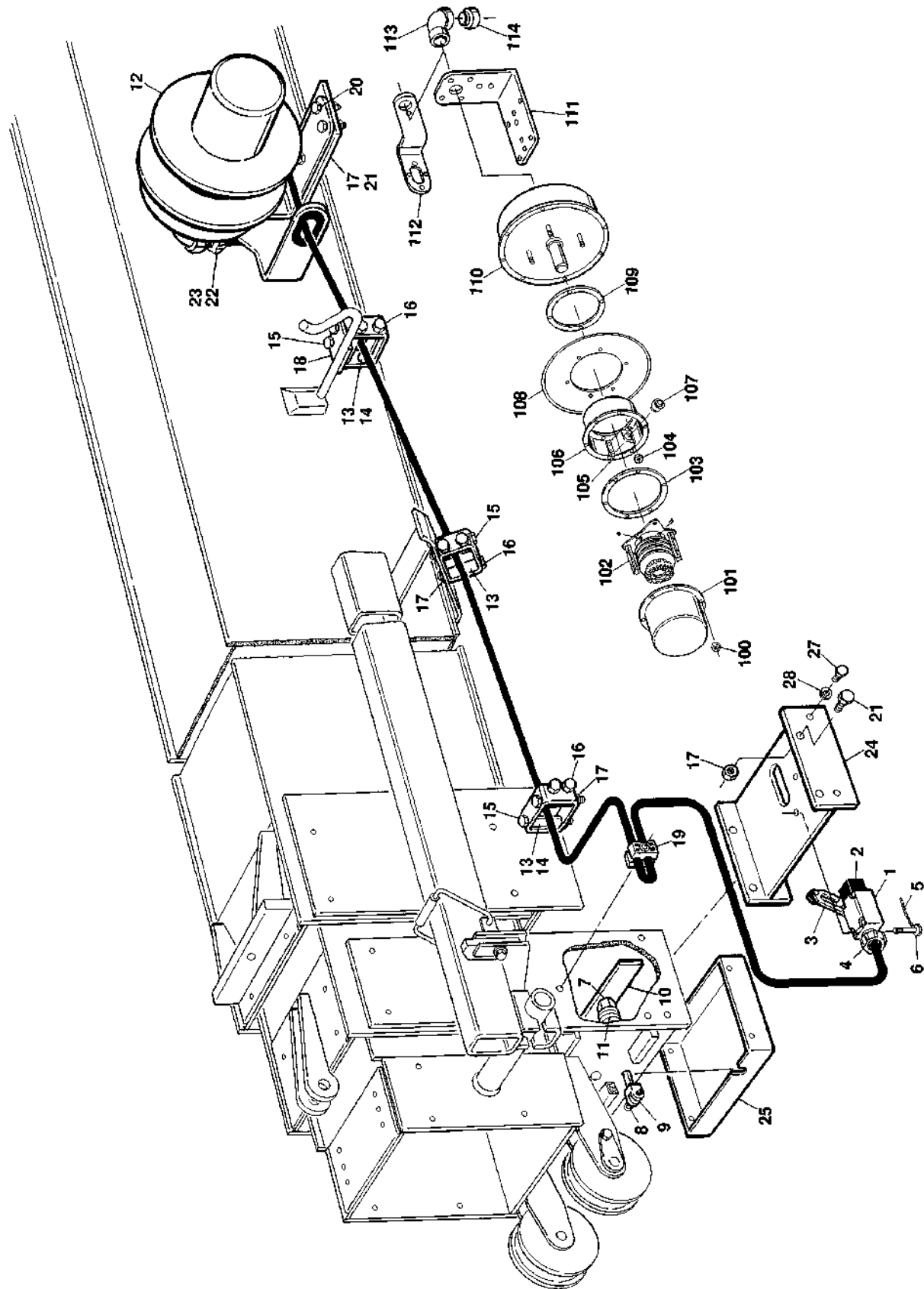

SECTION 3 BOOM

SECTION 3 BOOM

FIGURE 3-6. BROKEN CHAIN LIMIT SWITCH INSTALLATION (GERMAN/AUSTRIAN SPECS BUILT PRIOR TO S/N 28224)

FIG & ITEM #	PART NUMBER	DESCRIPTION	QTY.	REV.
	0253062	BROKEN CHAIN LIMIT SWITCH INSTALLATION	Ref.	3
1	4360277	Switch, Limit	1	
2	4360236	Head, Switch	1	
3	4360237	Arm, Actuator	1	
4	4460052	Connector, Strain Relief	1	
5	4920140	Wire, Safety	1	
6	3900168	Screw, Special	2	
7	3303240	Locknut	1	
8	3450202	Pin, Cotter 1/16" x 1/2"	1	
9	1360250	Clevis, Chain	1	
10	3536145	Plate, Switch	1	
11	4160098	Washer, Bellville	48	
12	3680051	Cable Reel Assembly (See Items 100-114 For Breakdown)	1	
13	4565798	Tube, Cable	6	
14	4565799	Tube, Cable	24	
15	0641630	Bolt 3/8"-16NC x 3 3/4"	12	
16	0641632	Bolt 3/8"-16NC x 4"	12	
17	3311605	Locknut 3/8"-16NC	31	
18	3536146	Plate, Mounting	1	
19	1320049	Clamp, Hose	1	
20	3536147	Plate, Mounting	1	
21	0641609	Bolt 3/8"-16NC x 1 1/8"	7	
22	0960407	Bushing, Reducer	1	
23	4460049	Connector, Strain Relief	1	
24	4844201	Plate, Switch Mounting	1	
25	3536148	Cover	1	
26	Not Used			
27	0721003	Bolt #10-24NC x 3/8"	4	
28	4761000	Lockwasher #10	4	
	3680051	CABLE REEL ASSEMBLY	Ref.	—
100	7010836	Nut	6	
101	7010837	Cover, Slip Ring	1	
102	7010848	Slip Ring Assembly	1	
103	7010847	Gasket, Cover	1	
104	7010836	Nut	4	
105	Not Available	Pin, Drive	1	
106	7010846	Drum/Entrance Assembly	1	
107	7010839	Cable Kit	1	
108	7010845	Flange, Front	1	
109	7010840	Gasket, Drum	1	
110	7010844	Cartridge, Spring	1	
111	7010841	Base	1	
112	7010843	Guide Arm Assembly	1	
113	Not Available	Fitting, 90°	1	
114	7010842	Seal, Watertight	1	

SECTION 3 BOOM

FIGURE 3-7. BOOM WIPERS INSTALLATION

FIG & ITEM #	PART NUMBER	DESCRIPTION	QTY.	REV.
		BOOM WIPERS INSTALLATION	Ref.	
	0239257	Prior To May 1992	Ref.	A
	0253245	May 1992 To Present	Ref.	A
1 to 6	Not Used			
7	0540074	Brush, Wiper (Base Top)	1	
8	Not Used			
9	0540078	Brush, Wiper (Outer Mid Top)	1	
10	0540075	Brush, Wiper (Base Side)	2	
11	0540077	Brush, Wiper (Inner Mid Side)	2	
12	0540079	Brush, Wiper (Outer Mid Side)	2	
13	2660067	Holder (Base Top)	1	
14	Not Used			
15	2660071	Holder (Outer Mid Top)	1	
16	2660068	Holder (Base Side)	2	
17	2660070	Holder (Inner Mid Side)	2	
18	2660072	Holder (Outer Mid Side)	2	
19	3820001	Rivet	30	
20	1670491	Cover	1	
21	0641404	Bolt 1/4"-20NC x 1/2"	4	
22	4761400	Lockwasher 1/4"	4	
23	4711600	Flatwasher 3/8"	4	
24 to 50	Not Used			
51		Mount, Wiper (Base Top) Options:	1	
	3200286	Prior to May 1992		
	3200344	May 1992 to Present		
52		Mount, Wiper (Inner Mid Top) Options:	A/R	
	3200288	Prior to May 1992	1	
	3200346	May 1992 to Present	2	
53		Mount, Wiper (Outer Mid Top) Options:	1	
	3200290	Prior to May 1992		
	3200348	May 1992 to Present		
54		Mount, Wiper (Base Side) Options:	2	
	3200287	Prior to May 1992		
	3200345	May 1992 to Present		
55		Mount, Wiper (Inner Mid Side) Options:	2	
	3200289	Prior to May 1992		
	3200347	May 1992 to Present		
56		Mount, Wiper (Outer Mid Side) Options:	2	
	3200291	Prior to May 1992		
	3200349	May 1992 to Present		
57		Brush, Wiper (Inner Mid Top) Options:	A/R	
	0540076	Prior to May 1992	1	
	0540089	May 1992 to Present	2	
58		Holder (Inner Mid Top) Options:	A/R	
	2660069	Prior to May 1992	1	
	2660085	May 1992 to Present	2	

SECTION 3 BOOM

**S
E
C
T
I
O
N

3

B
O
O
M**

FIGURE 3-7. BOOM WIPERS INSTALLATION (CONTINUED)

FIG & ITEM #	PART NUMBER	DESCRIPTION	QTY.	REV.

SECTION 4 PLATFORMS

TABLE OF CONTENTS		
FIGURE	DESCRIPTION	PAGE
4-1	PLATFORM COMPONENTS INSTALLATION - 100HX/110HX	4-2
4-2	PLATFORM COMPONENTS INSTALLATION - 100HX+10/110HXER (Prior to May 1992)	4-6
4-3	PLATFORM COMPONENTS INSTALLATION - 100HX+10/110HXER (May 1992 to Present) . .	4-10
4-4	ROTATOR MOTOR ASSEMBLY	4-14
4-5	CONSOLE BOX ASSEMBLY - OEM CONTROLLERS (Prior to September 1991)	4-16
4-6	CONSOLE BOX ASSEMBLY - OEM CONTROLLERS (September 1991 to Present)	4-20
4-7	CONTROLLER ASSEMBLIES - OEM	4-26
4-8	OPTIONAL COMMON PLATFORM MOUNTED COMPONENTS	4-28

SECTION 4 PLATFORMS

FIGURE 4-1. PLATFORM COMPONENTS INSTALLATION - 100HX/110HX

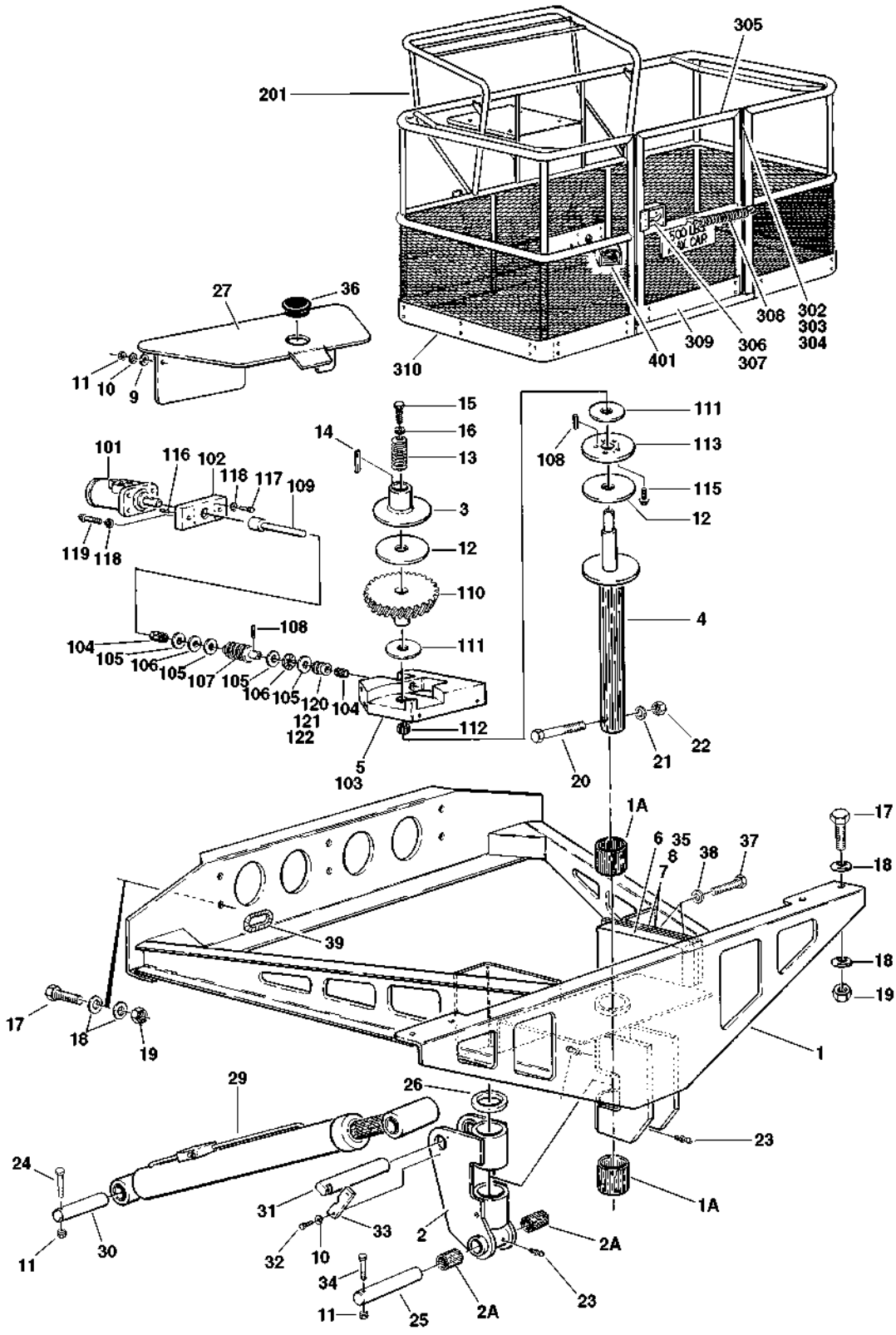

SECTION 4 PLATFORMS

FIGURE 4-1. PLATFORM COMPONENTS INSTALLATION - 100HX/110HX

FIG & ITEM #	PART NUMBER	DESCRIPTION	QTY.	REV.
	0239183	SUPPORT INSTALLATION	Ref.	6
1	4843099	Support Weldment	1	
1A	0961259	Bushing	2	
2	0239182	Pivot Weldment	1	
2A	0960565	Bushing, Bronze	2	
3	1120299	Cap	1	
4	4842915	Shaft, Rotator	1	
5	0235238	Rotator Assembly (See Items 101-126 for Breakdown)	1	
6	0361675	Bar, Stop	1	
7	4070705	Shim 1/8"	A/R	
8	4070706	Shim 1/16"	A/R	
9	4751500	Flatwasher 5/16"	2	
10	4761500	Lockwasher 5/16"	4	
11	3311501	Nut 5/16"-18NC	4	
12	3340454	Pad, Brake	2	
13	4160026	Washer, Belleville	8	
14	2880404	Key	1	
15	0652014	Bolt 5/8"-18NF x 1 3/4"	1	
16	4752000	Flatwasher 5/8"	1	
17	0681610	Bolt 3/8"-16NC x 1 1/4" (Grade 8)	10	
18	4751600	Flatwasher 3/8"	20	
19	3300143	Locknut 3/8"-16NC	10	
20	0641840	Bolt 1/2"-13NC x 5"	1	
21	4751800	Flatwasher 1/2"	1	
22	3311805	Locknut 1/2"-13NC	1	
23	2160002	Fitting, Grease	3	
24	0641520	Bolt 5/16"-18NC x 2 1/2"	1	
25	3421583	Pin	1	
26	4740158	Washer, Thrust	1	
27	1670451	Cover	1	
28	4300038	Stud (Welded on part - Not Shown)	2	
29		Platform Level Cylinder Assembly Options (See Section 5 for Breakdown):	1	
	1681973	Prior to May 1992		
	1682590	May 1992 to S/N 33111		
	1683536	S/N 33111 to Present		
30	3421582	Pin	1	
31	3421577	Pin	1	
32	3532054	Plate, Retainer	1	
33	0641506	Bolt 5/16"-18NC x 3/4"	2	
34	0641524	Bolt 5/16"-18NC x 3"	1	
35	4070707	Shim 1/32"	A/R	
36	3520035	Plug, Hole (Prior to February 1994)	1	
37	0641816	Bolt 1/2"-13NC x 2"	2	
38	4761800	Lockwasher 1/2"	2	
39	4060804	Flexguard	10.5in/27cm	

SECTION 4 PLATFORMS

FIGURE 4-1. PLATFORM COMPONENTS INSTALLATION - 100HX/110HX (CONTINUED)

FIG & ITEM #	PART NUMBER	DESCRIPTION	QTY.	REV.
	0235238	ROTATOR ASSEMBLY Note: For Machines Built Prior to September 1991 refer to Service Information Bulletin #91-5 for required upgrade.	Ref.	E
101	3160083	Rotator Motor Assembly (See Figure 4-4 for Break-down)	1	
102	0080099	Adapter, Motor	1	
103	2760064	Housing, Gear	1	
104	0440134	Bearing, Sleeve	2	
105	4740199	Washer, Thrust	4	
106	0440120	Bearing, Thrust	2	
107	2440043	Gear, Worm	1	
108	3440816	Rollpin 1/4" x 1"	4	
109	0080098	Adapter, Motor to Worm Gear	1	
110	2440044	Gear, Worm	1	
111	4740256	Washer, Thrust	2	
112	0440135	Bearing, Sleeve	1	
113	1760068	Disc, Brake	1	
114	Not Used			
115	3931010	Bolt, Socket Head #10-24NC x 5/8"	5	
116	3441228	Rollpin 3/8" x 1 3/4"	2	
117	3931620	Bolt, Socket Head 3/8"-16NC x 1 1/4"	2	
118	4761600	Lockwasher 3/8"	6	
119	3931612	Bolt, Socket Head 3/8"-16NC x 3/4"	4	
120	4070585	Shim.010	A/R	
121	4070586	Shim.005	A/R	
122	4070587	Shim.002	A/R	
123	0100019	Loctite #271 (Not Shown)	A/R	
124	0100021	Primer (Not Shown)	A/R	
125	2160001	Fitting, Grease - 90° (Not Shown)	1	
126	3020025	Grease (Not Shown)	A/R	
		PLATFORM WELDMENTS	Ref.	
201		Platform Options (Includes Items 301-307): 3' x 5' (91.5cm x 152.5cm)	1	
	3510301	Platform with Kickplates & Self-Closing Gate 3' x 6' (91.5cm x 183cm)		
	3510294	Platform without Kickplates		
	3510302	Platform with Kickplates & Self-Closing Gate 3' x 8' (91.5cm x 244cm)		
	3510295	Platform without Kickplates		
	3510303	Platform with Kickplates & Self-Closing Gate		

SECTION 4 PLATFORMS

FIGURE 4-1. PLATFORM COMPONENTS INSTALLATION - 100HX/110HX (CONTINUED)

FIG & ITEM #	PART NUMBER	DESCRIPTION	QTY.	REV.
		PLATFORM ASSEMBLY COMPONENTS	Ref.	
301	Not Required			
302	2600095	Pin, Hinge	2	
303	3311805	Locknut 1/2"-13NC	2	
304	2160006	Fitting, Grease	2	
305	1780253	Door Weldment	1	
306	2940006	Latch, Door	1	
307	2560010	Handle	1	
308	4160028	Spring, Tension	1	
309	3534508	Kickplate (Door)	1	
310		Kickplate (Ends) Options:	2	
	3534121	3' x 5' (91.5cm x 152.5cm) Platforms		
	3534122	3' x 6' (91.5cm x 183cm) Platforms		
	3534120	3' x 8' (91.5cm x 244cm) Platforms		
	0237963	FOOTSWITCH INSTALLATION	Ref.	7
401	0641408	Bolt 1/4"-20NC x 1"	3	
	3311405	Locknut 1/4"-20NC	3	
	4740362	Washer, Fender	3	
	4360031	Footswitch	1	
	7000625	Block, Contact	2	
	4460071	Connector, Strain Relief	1	

SECTION 4 PLATFORMS

FIGURE 4-2. PLATFORM COMPONENTS INSTALLATION - 100HX+10/110HXER (PRIOR TO MAY 1992)

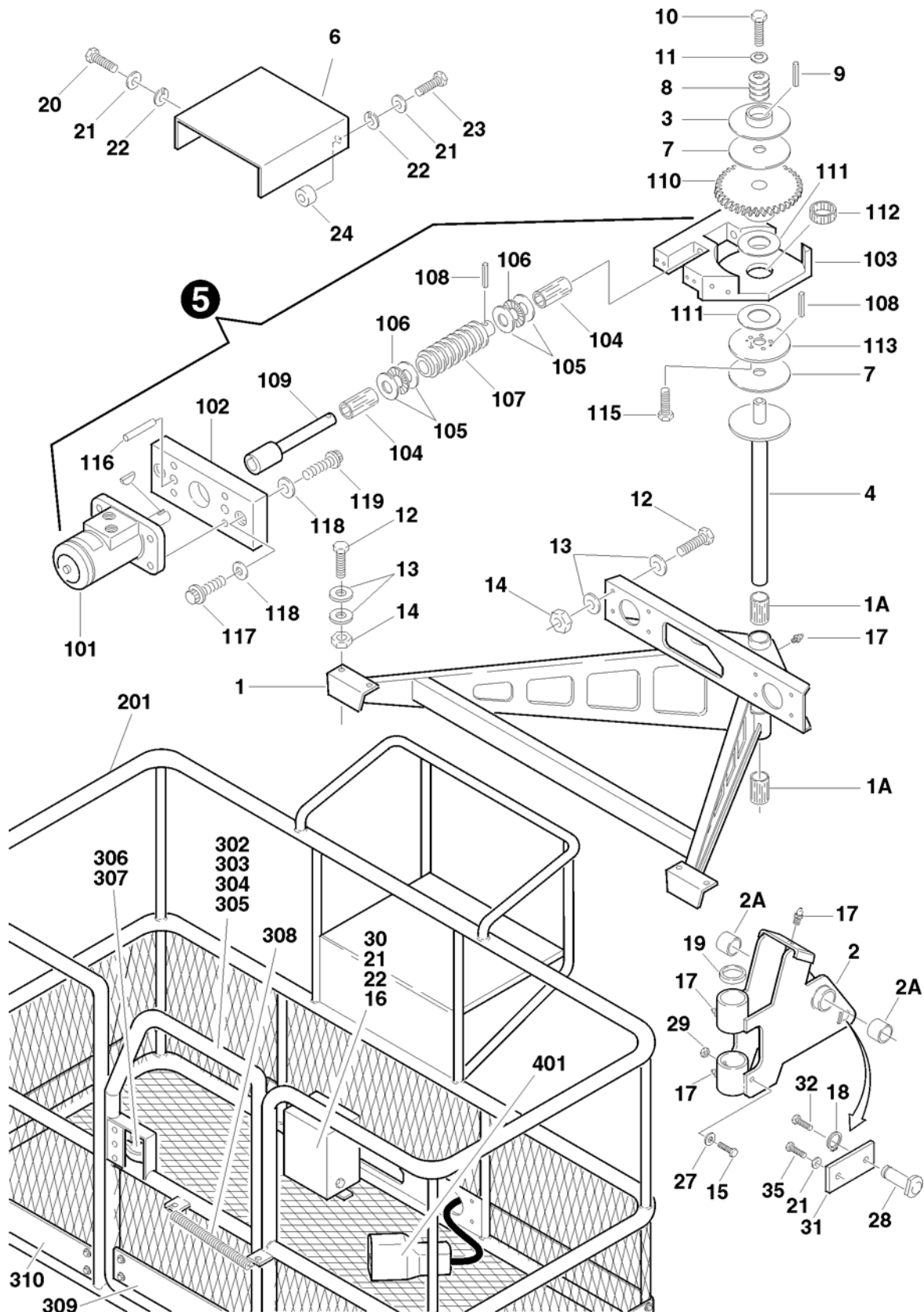

SECTION 4 PLATFORMS

FIGURE 4-2. PLATFORM COMPONENTS INSTALLATION - 100HX+10/110HXER (PRIOR TO MAY 1992)

FIG & ITEM #	PART NUMBER	DESCRIPTION	QTY.	REV.
	0237672	ROTATOR AND SUPPORT INSTALLATION	Ref.	D
1	4842609	Support Weldment	1	
1A	0960569	Bushing, Bronze	2	
2		Pivot Weldment Options:	1	
	0237975	Pivot (Prior to January 1991)		
	0251512	Pivot (January 1991 to May 1992)		
2A	0961185	Bushing, Bronze	2	
3	1120299	Cap	1	
4	4842046	Rotator Shaft	1	
5	0235238	Rotator Assembly (See Items 201-226 for Breakdown)	1	
6	1670421	Cover	1	
7	3340454	Pad, Brake	2	
8	4160026	Washer, Belleville	8	
9	2880404	Key	1	
10	0652014	Bolt 5/8"-18NF x 1 3/4"	1	
11	4752000	Flatwasher 5/8"	1	
12	0681610	Bolt 3/8"-16NC x 1 1/4" (Grade 8)	10	
13	4751600	Flatwasher 3/8"	21	
14	3300143	Locknut 3/8"-16NC	10	
15	0641836	Bolt 1/2"-13NC x 4 1/2"	1	
16	1670422	Cover, Motor	1	
17	2160002	Fitting, Grease	4	
18	3760237	Ring, Retaining (Prior to January 1991)	1	
19	4740158	Washer, Thrust	1	
20	0641404	Bolt 1/4"-20NC x 1/2"	1	
21	4761400	Lockwasher 1/4"	A/R	
22	4751400	Flatwasher 1/4"	A/R	
23	0641408	Bolt 1/4"-20NC x 1"	1	
24	4562083	Spacer	1	
25	0641811	Bolt 1/2"-13NC x 1 3/8"	2	
26	4761800	Lockwasher 1/2" (Prior to	2	
27	4751800	Flatwasher 1/2"	3	
28		Pin Options:	1	
	3421426	Pin (Prior to January 1991)		
	3421825	Pin (January 1991 to November 1991)		
	3422019	Pin (November 1991 to May 1992)		
29	3311805	Locknut 1/2"-13NC	1	
30	0641406	Bolt 1/4"-20NC x 3/4"	2	
31		Retainer Options:	1	
	Not Required	(Prior to January 1991)		
	4740385	Washer (January 1991 to November 1991)		
	0362079	Bar (November 1991 to May 1992)		
32	3900159	Screw, Countersunk 1/2"-13NC x 3/4" (Used January 1991 to May 1992)	1	
33	0100011	Loctite #242 (Not Shown)	A/R	
34	0901411	Mount, Rotator (Not Shown)	1	

SECTION 4 PLATFORMS

FIGURE 4-2. PLATFORM COMPONENTS INSTALLATION - 100HX+10/110HXER (PRIOR TO MAY 1992) (CONTINUED)

FIG & ITEM #	PART NUMBER	DESCRIPTION	QTY.	REV.
35	0641405	Bolt 1/4"-20NC x 5/8" (Used November 1991 to May 1992)	1	
	0235238	ROTATOR ASSEMBLY Note: For Machines Built Prior to September 1991 refer to Service Information Bulletin #91-5 for required upgrade.	Ref.	E
101	3160083	Rotator Motor Assembly (See Figure 4-4 for Break-down)	1	
102	0080099	Adapter, Motor	1	
103	2760064	Housing, Gear	1	
104	0440134	Bearing, Sleeve	2	
105	4740199	Washer, Thrust	4	
106	0440120	Bearing, Thrust	2	
107	2440043	Gear, Worm	1	
108	3440816	Rollpin 1/4" x 1"	4	
109	0080098	Adapter, Motor to Worm Gear	1	
110	2440044	Gear, Worm	1	
111	4740256	Washer, Thrust	2	
112	0440135	Bearing, Sleeve	1	
113	1760068	Disc, Brake	1	
114	Not Used			
115	3931010	Bolt, Socket Head #10-24NC x 5/8"	5	
116	3441228	Rollpin 3/8" x 1 3/4"	2	
117	3931620	Bolt, Socket Head 3/8"-16NC x 1 1/4"	2	
118	4761600	Lockwasher 3/8"	6	
119	3931612	Bolt, Socket Head 3/8"-16NC x 3/4"	4	
120	4070585	Shim .010	A/R	
121	4070586	Shim .005	A/R	
122	4070587	Shim .002	A/R	
123	0100019	Loctite #271	A/R	
124	0100021	Primer	A/R	
125	2160001	Fitting, Grease - 90°	1	
126	3020025	Grease	A/R	
		PLATFORM WELDMENTS	Ref.	
201		Platform Options (Includes Items 301-307): 3' x 5' (91.5cm x 152.5cm)	1	
	3510299	Platform with Kickplates & Self-Closing Gate 3' x 6' (91.5cm x 183cm)		
	3510284	Platform without Kickplates & Self-Closing Gate		
	3510300	Platform with Kickplates & Self-Closing Gate		

SECTION 4 PLATFORMS

FIGURE 4-2. PLATFORM COMPONENTS INSTALLATION - 100HX+10/110HXER (PRIOR TO MAY 1992) (CONTINUED)

FIG & ITEM #	PART NUMBER	DESCRIPTION	QTY.	REV.
		PLATFORM ASSEMBLY COMPONENTS	Ref.	
301	Not Required			
302	2600095	Pin, Hinge	2	
303	3311805	Locknut 1/2"-13NC	2	
304	2160006	Fitting, Grease	2	
305	1780253	Door Weldment	1	
306	2940006	Latch, Door	1	
307	2560010	Handle	1	
308	4160028	Spring, Tension	1	
309	3534508	Kickplate (Door)	1	
310		Kickplate (Ends) Options:	2	
	3534121	3' x 5' (91.5cm x 152.5cm) Platforms		
	3534122	3' x 6' (91.5cm x 183cm) Platforms		
	3534120	3' x 8' (91.5cm x 244cm) Platforms		
	0237963	FOOTSWITCH INSTALLATION	Ref.	7
401	0641408	Bolt 1/4"-20NC x 1"	3	
	3311405	Locknut 1/4"-20NC	3	
	4740362	Washer, Fender	3	
	4360031	Footswitch	1	
	7000625	Block, Contact	2	
	4460071	Connector, Strain Relief	1	

SECTION 4 PLATFORMS

FIGURE 4-3. PLATFORM COMPONENTS INSTALLATION - 100HX+10/110HXER (MAY 1992 TO PRESENT)

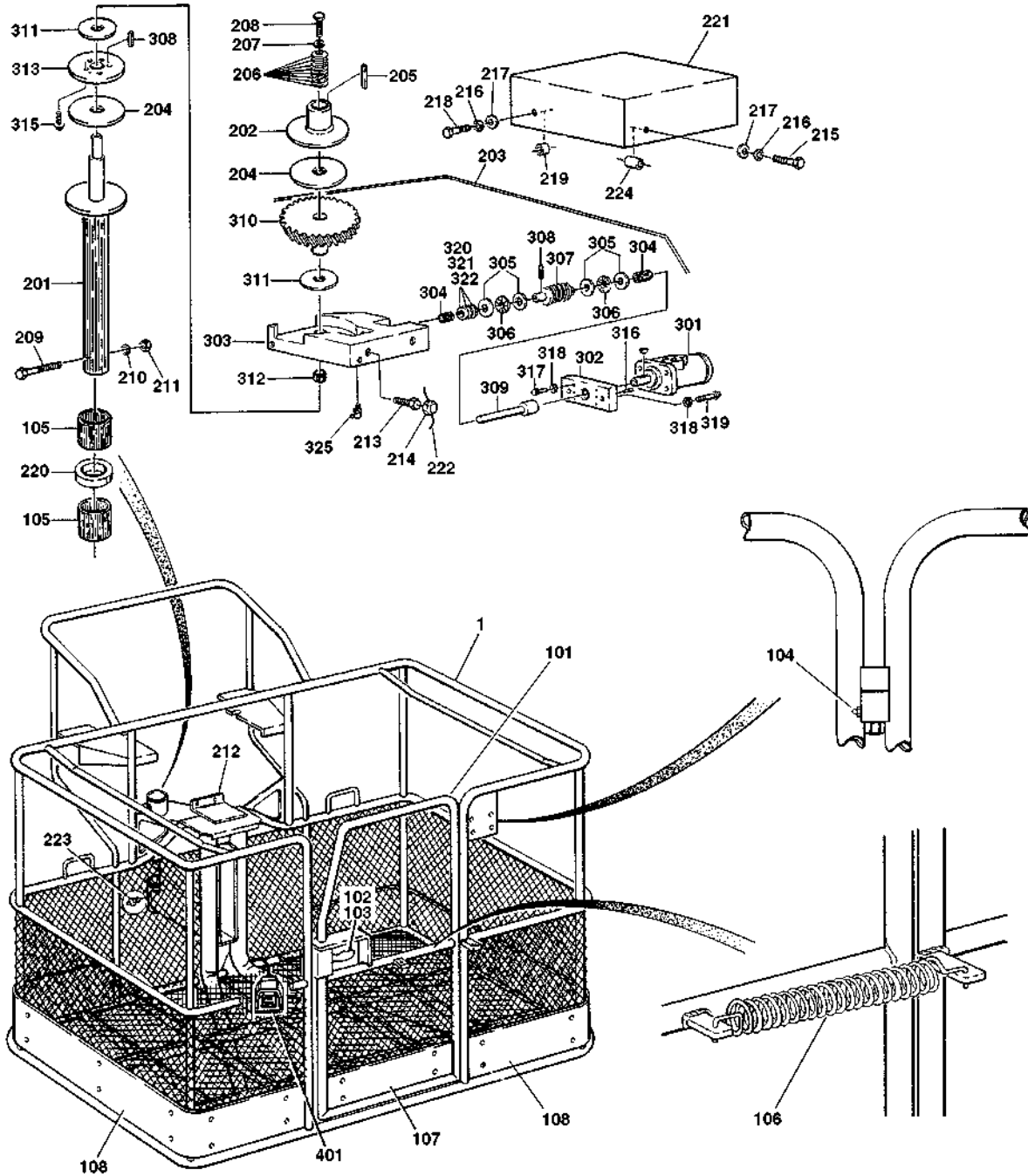

SECTION 4 PLATFORMS

FIGURE 4-3. PLATFORM COMPONENTS INSTALLATION - 100HX+10/110HXER (MAY 1992 TO PRESENT)

FIG & ITEM #	PART NUMBER	DESCRIPTION	QTY.	REV.
1		PLATFORM ASSEMBLY OPTIONS:	1	
	3510304	3' x 5' (91.5cm x 152.5cm) Platform with Kickplates & Self-Closing Gate		
	3510364	3' x 6' (91.5cm x 183cm) Platform without Kickplates & Self-Closing Gate		
	3510365	Platform with Kickplates & Self-Closing Gate		
	3510405	Platform with Kickplates & Slide Bar		
	3510306	3' x 8' (91.5cm x 244cm) Platform with Kickplates & Self-Closing Gate		
		PLATFORM ASSEMBLY COMPONENTS	Ref.	
101	1780253	Door Weldment	1	
102	2940006	Latch, Door	1	
103	2560010	Handle, Latch	1	
104	2160006	Fitting, Grease	2	
105	0960564	Bushing, Bronze	2	
106	4160028	Spring, Tension	1	
107	3536066	Kickplate (Door) (Was P/N 3534508)	1	
108		Kickplate (Ends) Options:	2	
	3534121	3' x 5' (91.5cm x 152.5cm) Platforms		
	3534146	3' x 6' (91.5cm x 183cm) Platforms		
	3534120	3' x 8' (91.5cm x 244cm) Platforms		
	0252682	ROTATOR AND SUPPORT INSTALLATION	Ref.	2
201	4842046	Shaft Weldment	1	
202	1120299	Cap	1	
203	0235238	Rotator Assembly (See Items 301-325 for Breakdown)	1	
204	3340454	Pad, Brake	2	
205	2880404	Key	1	
206	4160026	Washer, Belleville	8	
207	4752000	Flatwasher 5/8"	1	
208	0652014	Bolt 5/8"-18NF x 1 3/4"	1	
209	0641836	Bolt 1/2"-13NC x 4 1/2"	1	
210	4751800	Flatwasher 1/2"	1	
211	3311805	Locknut 1/2"-13NC	1	
212	0901834	Bracket	1	
213	0641811	Bolt 1/2"-13NC x 1 3/8"	2	
214	1380137	Clip, Retainer	2	
215	0641412	Bolt 1/4"-20NC x 1 1/2"	1	
216	4761400	Lockwasher 1/4"	2	
217	4751400	Flatwasher 1/4"	2	
218	0641408	Bolt 1/4"-20NC x 1"	1	
219	4562083	Tube, Spacer	1	
220	4740158	Washer, Thrust	1	
221	1670632	Cover	1	
222	4920986	Wire, Safety	1 ft./30cm	

SECTION 4 PLATFORMS

FIGURE 4-3. PLATFORM COMPONENTS INSTALLATION - 100HX+10/110HXER (MAY 1992 TO PRESENT) (CONTINUED)

FIG & ITEM #	PART NUMBER	DESCRIPTION	QTY.	REV.
223	2160002	Fitting, Grease	2	
224	4565665	Tube, Spacer	1	
	0235238	ROTATOR ASSEMBLY	Ref.	E
301	3160083	Rotor Motor Assembly (See Figure 4-4 for Breakdown)	1	
302	0080099	Adaptor, Motor	1	
303	2760064	Housing, Gear	1	
304	0440134	Bearing, Sleeve	2	
305	4740199	Washer, Thrust	4	
306	0440120	Bearing, Thrust	2	
307	2440043	Gear, Worm	1	
308	3440816	Rollpin 1/4" x 1"	4	
309	0080098	Adaptor - Motor to Worm Gear	1	
310	2440044	Gear, Worm	1	
311	4740256	Washer, Thrust	2	
312	0440135	Bearing, Sleeve	1	
313	1760068	Disc, Brake	1	
314	Not Used			
315	3931010	Bolt, Socket Head #10-24NC x 5/8"	5	
316	3441228	Rollpin 3/8" x 1 3/4"	2	
317	3931620	Bolt, Socket Head 3/8" - 16NC x 1 1/4"	2	
318	4761600	Lockwasher 3/8"	6	
319	3931612	Bolt, Socket Head 3/8" - 16NC x 3/4"	4	
320	4070585	Shim, Rotator -.010"/.25mm	A/R	
321	4070586	Shim, Rotator -.005"/.13mm	A/R	
322	4070587	Shim, Rotator -.002"/.05mm	A/R	
323	Not Used			
324	Not Used			
325	2160001	Fitting, Grease - 90°	1	
	0100019	Loctite #271	A/R	
	0100021	Primer, Locking - "N"	A/R	
	3020025	Grease	A/R	
	0237963	FOOTSWITCH INSTALLATION	Ref.	7
401	0641408	Bolt 1/4"-20NC x 1"	3	
	3311401	Nut 1/4"-20NC	3	
	4740362	Flatwasher 1/4"	3	
	Not Used			
	4360031	Footswitch Assembly	1	
	7000625	Block, Contact	2	
	4460071	Connector	1	

SECTION 4 PLATFORMS

FIGURE 4-3. PLATFORM COMPONENTS INSTALLATION - 100HX+10/110HXER (MAY 1992 TO PRESENT) (CONTINUED)

FIG & ITEM #	PART NUMBER	DESCRIPTION	QTY.	REV.

SECTION 4 PLATFORMS

FIGURE 4-4. ROTATOR MOTOR ASSEMBLY

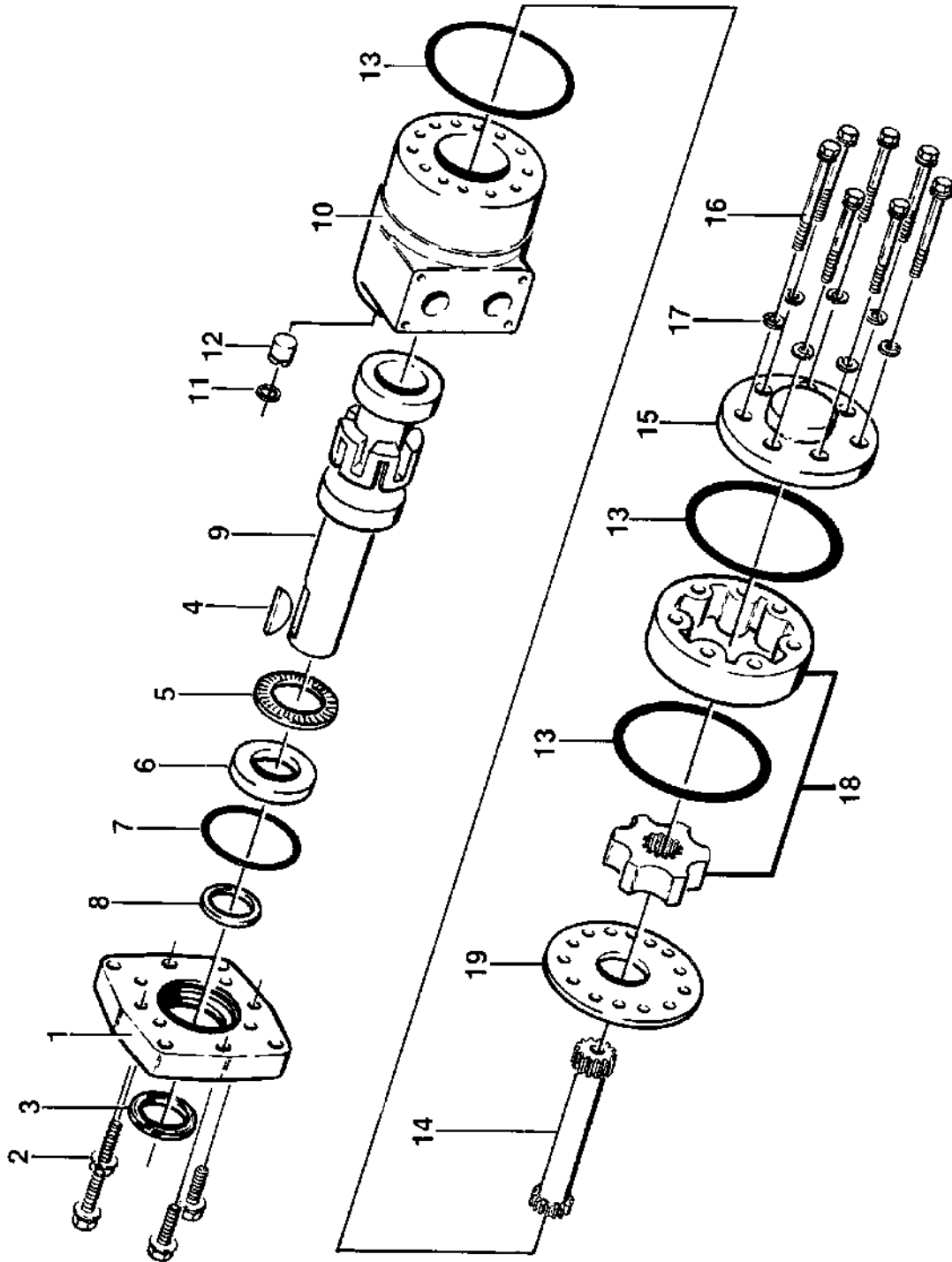

SECTION 4 PLATFORMS

FIGURE 4-4. ROTATOR MOTOR ASSEMBLY

FIG & ITEM #	PART NUMBER	DESCRIPTION	QTY.	REV.
	3160083	ROTATOR MOTOR ASSEMBLY	Ref.	A
1	7002105	Flange, Mounting	1	
2	7002123	Screw, Cap	4	
3	Kit	Seal, Dust	1	
4	7002104	Key, Woodruff	1	
5	7002111	Bearing, Thrust Needle	1	
6	7002117	Thrust, Bearing Race	1	
7	Kit	Seal, O-Ring	1	
8	Kit	Seal, Pressure	1	
9	7002116	Shaft, Output	1	
10	7002103	Housing	1	
11	Kit	Seal	1	
12	Kit	Plug, Housing	1	
13	7002115	Seal, O-Ring	3	
14	7002112	Drive	1	
15	7002107	Cap, End	1	
16	7002100	Screw, Cap	7	
17	7000166	Lockwasher	7	
18	7002125	Gerotor Sub-Assembly	1	
19	7002110	Plate, Spacer	1	

	2900455	Seal Kit (Includes Items 3,7,8,11 and 12) (P/N 101-1009-007)	1	
	2900733	Seal Kit (Includes Items 3,7,8,11 and 12) (P/N's 101-1009-008 and 101-1009-009)	1	
		Note: Identify by P/N stamped on nameplate located on Item 10.		

SECTION 4 PLATFORMS

FIGURE 4-5. CONSOLE BOX ASSEMBLY (PRIOR TO SEPTEMBER 1991)

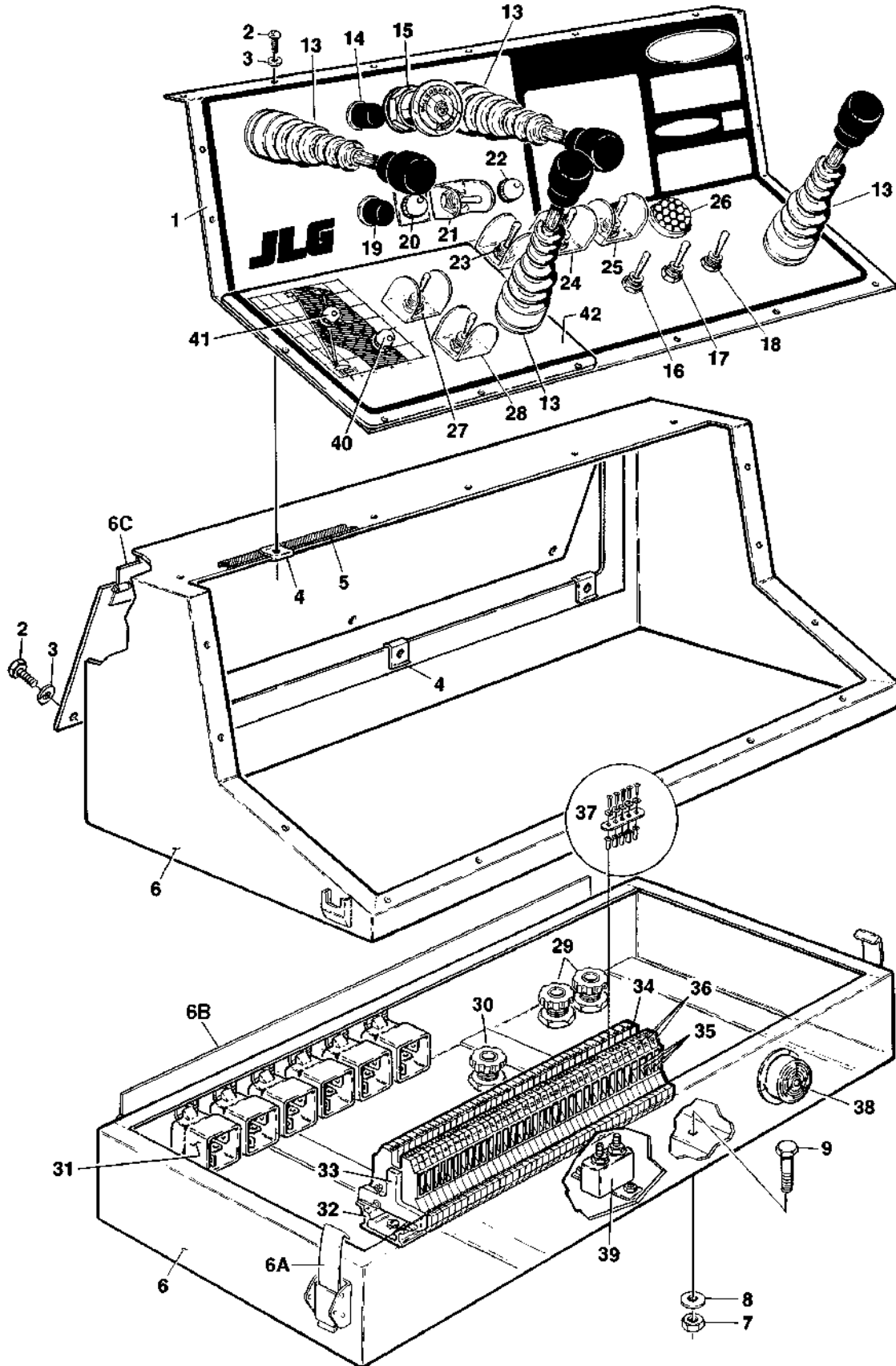

SECTION 4 PLATFORMS

FIGURE 4-5. CONSOLE BOX ASSEMBLY (PRIOR TO SEPTEMBER 1991)

FIG & ITEM #	PART NUMBER	DESCRIPTION	QTY.	REV.
	0860672	CONSOLE BOX ASSEMBLY (110HX)	Ref.	C
	0860673	CONSOLE BOX ASSEMBLY (100HX+10 AND 110HXER)	Ref.	B
1		Nameplate Options:	1	
	3251853	100HX AND 110HX		
	3251854	100HX+10 AND 110HXER		
2	0751006	Screw, Pan Head #10-24NC x 3/4"	21	
3	4740120	Washer, Nylon	21	
4	3300177	Nut, Tinnerman	21	
5	4420038	Tape, Insulation	1m	
	0100001	Adhesive	A/R	
6	0860538	Box, Console	1	
6A	2940052	Latch	2	
6B	2600132	Hinge (Top to Bottom)	1	
6C	2600105	Hinge (Rear Access Panel)	1	
7	3311505	Locknut 5/16"-18NC	4	
8	4751500	Flatwasher 5/16"	8	
9	0641508	Bolt 5/16"-18NC x 1"	4	
10	Not Used			
11	Not Used			
12	Not Used			
13	1600092	OEM Controller Assembly (See Figure 4-7 for Break-down)	4	
14	4360274	Switch, Push Button (Horn)	1	
	3790015	O-Ring	1	
15	4360132	Switch, Push-Pull (Emergency Stop)	1	
	4360131	Lens	1	
16	4360199	Switch, Toggle (High Engine)	1	
	3790012	O-Ring	1	
17	4360199	Switch, Toggle (Pump Volume)	1	
	3790012	O-Ring	1	
18	4360199	Switch, Toggle (Wheel Motor Speed)	1	
	3790012	O-Ring	1	
19	4360274	Switch, Push Button (Start)	1	
	3790015	O-Ring	1	
20	2920026	Light, Indicator - Red	1	
	2920029	Bulb	1	
	3252025	Nameplate - Broken Extend Chain	1	
21	4360202	Switch, Toggle (Extend-A-Reach Lift) (100HX+10 and 110HXER Only)	1	
	3790012	O-Ring	1	
22	2920027	Light, Indicator - Green (Axles Set)	1	
	2920024	Bulb	1	
23	4360202	Switch, Toggle (Rotate)	1	
	3790012	O-Ring	1	
	4060229	Shield	1	
24	4360202	Switch, Toggle (Level)	1	
	3790012	O-Ring	1	

SECTION 4 PLATFORMS

FIGURE 4-5. CONSOLE BOX ASSEMBLY (PRIOR TO SEPTEMBER 1991) (CONTINUED)

FIG & ITEM #	PART NUMBER	DESCRIPTION	QTY.	REV.
	4060229	Shield	1	
25	4360199	Switch, Toggle (Creep)	1	
	3790012	O-Ring	1	
	4060229	Shield	1	
26	2920015	Lamp, Indicator (Out of Level)	1	
27	4360204	Switch, Toggle (Auxiliary Power)	1	
	3790012	O-Ring	1	
	4060229	Shield	1	
28	4360202	Switch, Toggle (Steer)	1	
	3790012	O-Ring	1	
	4060229	Shield	1	
29	4460244	Connector, Strain Relief	2	
	0960238	Bushing	2	
	3300048	Nut, Conduit	2	
30	4460071	Connector, Strain Relief	1	
	0960238	Bushing	1	
	3300048	Nut, Conduit	1	
31	3740049	Relay	6	
	4761000	Lockwasher #10	6	
	3311001	Nut #10-24NC	6	
32	3640500	Rail, Mounting	1	
	3910608	Screw, Round Head #6-32NC x 1/2"	2	
	4750600	Flatwasher #6	2	
	4760600	Lockwasher #6	2	
	3310601	Nut #6-32NC	2	
33	4460299	Stop, Terminal Strip	2	
34	4460300	Barrier, Terminal End	1	
35	4460298	Block, Terminal	A/R	
36	4460301	Strip, Marking	1	
37	4460311	Bar, Buss - 5 Position	1	
	4460305	Screw, Terminal Block	5	
	4460306	Washer, Terminal Block	5	
	4460307	Sleeve, Terminal Block	5	
38	0140019	Alarm	1	
39	4360209	Breaker, Circuit - 20 Amp	1	
	3911012	Screw, Round Head #10-24NC x 3/4"	1	
	4761000	Lockwasher #10	1	
	3311001	Nut #10-24NC	1	
40	2920026	Light, Indicator - Red	1	
	2920029	Bulb	1	
41	2920090	Light, Indicator - Blue	1	
	2920029	Bulb	1	
42		Grid Nameplate Options:	1	
	3252015	100HX and 110HX		
	3252018	100HX+10 and 110HXER		

SECTION 4 PLATFORMS

FIGURE 4-5. CONSOLE BOX ASSEMBLY (PRIOR TO SEPTEMBER 1991) (CONTINUED)

FIG & ITEM #	PART NUMBER	DESCRIPTION	QTY.	REV.

SECTION 4 PLATFORMS

FIGURE 4-6. CONSOLE BOX ASSEMBLY (SEPTEMBER 1991 TO PRESENT)

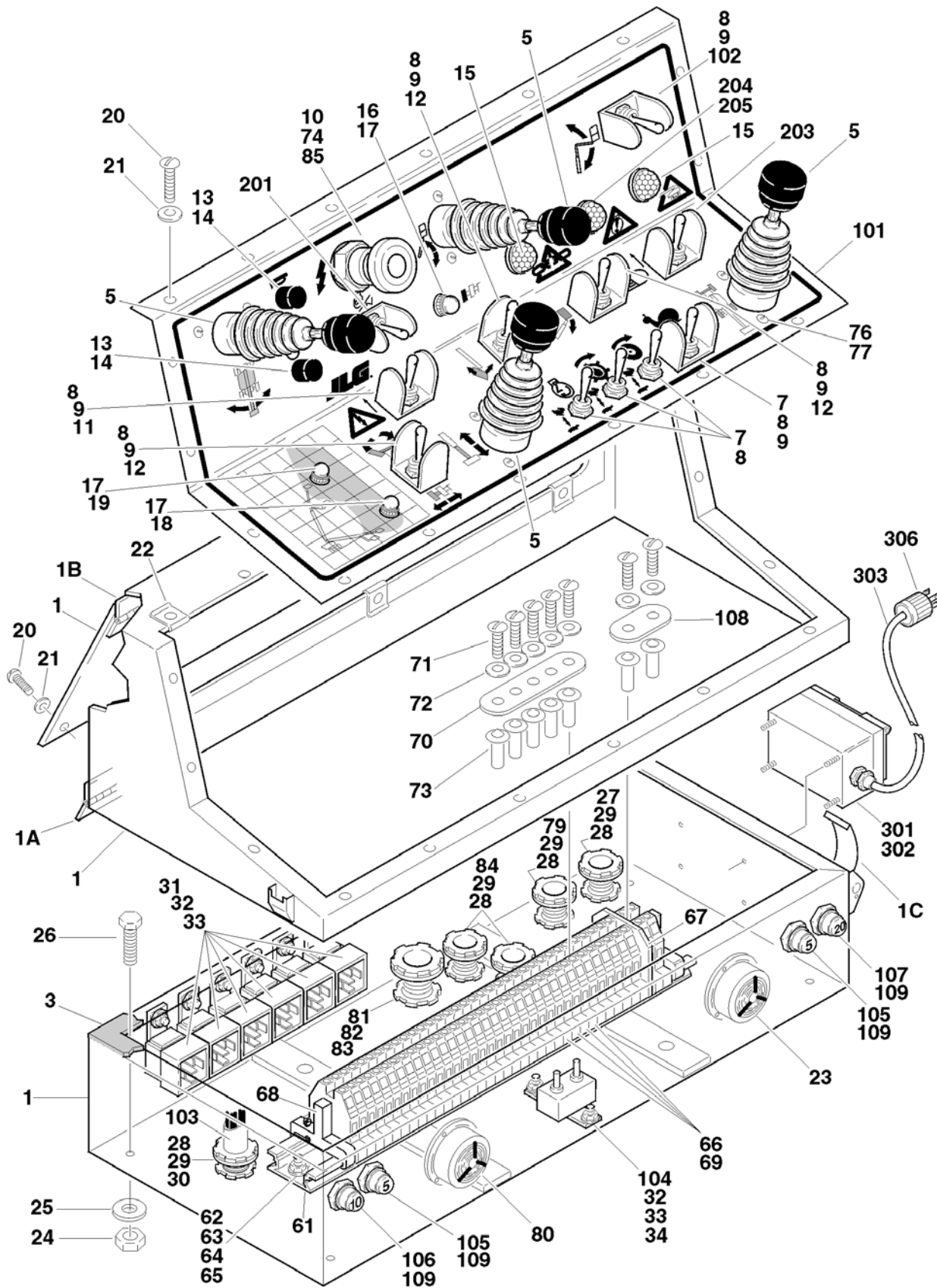

SECTION 4 PLATFORMS

FIGURE 4-6. CONSOLE BOX ASSEMBLY (SEPTEMBER 1991 TO PRESENT)

FIG & ITEM #	PART NUMBER	DESCRIPTION	QTY.	REV.
	0258187	CONSOLE BOX ASSEMBLY - 100HX	Ref.	3
	0860672	CONSOLE BOX ASSEMBLY - 110HX BUILT PRIOR TO S/N 28224	Ref.	G
	0861094	CONSOLE BOX ASSEMBLY - 110HX BUILT S/N 28224 TO PRESENT	Ref.	4/C
	0860673	CONSOLE BOX ASSEMBLY - 100HX+10/110HXER BUILT PRIOR TO S/N 28224	Ref.	I
	0861093	CONSOLE BOX ASSEMBLY - 100HX+10/110HXER BUILT S/N 28224 TO PRESENT	Ref.	4/C
1	0860538	Box Weldment	1	
1A	2600132	Hinge (Top to Bottom)	1	
1B	2600105	Hinge (Rear Access Door)	1	
1C	2940052	Latch	2	
2	Not Used			
3	4420038	Tape, Insulation	39 in/1m	
4	0100001	Adhesive (Not Shown)	A/R	
5		Controller Assembly Options (See Figure 4-7 for Break-down):	4	
	1600092	Prior to S/N 27148		
	1600247	S/N 27148 to Present		
6	Not Used			
7	4360199	Switch, Toggle	4	
8	3790012	O-Ring	A/R	
9	4060229	Shield, Switch	A/R	
10		Switch, Emergency Stop Options:	1	
	4360289	Prior to S/N 47729		
	4360475	S/N 47729 to Present		
		Cap Options:	1	
	7012611	Cap, Mushroom Head (Used on Switch p/n 4360289)		
	7012612	Boot (Used on Switch p/n 4360289)	1	
	7020175	Cap, Red (Used on Switch p/n 4360475)		
	7020176	Contact Block (Used on Switch p/n 4360475)		
11	4360204	Switch, Toggle	1	
12	4360202	Switch, Toggle	3	
13	4360274	Switch, Push Button	2	
14	3790015	O-Ring	2	
15	2920015	Lamp	1	
16	2920027	Lamp - Green	1	
17	2920029	Bulb	3	
18	2920026	Lamp - Red	1	
19	2920090	Lamp - Blue	1	
20	0751006	Screw #10-24NC x 3/4"	21	
21	4740120	Washer, Nylon	21	
22	3300177	Nut, Tinnerman	21	
23	0140019	Alarm	1	
24	3311505	Locknut 5/16"-18NC	4	
25	4751500	Flatwasher 5/16"	8	
26	0641508	Bolt 5/16"-18NC x 1"	4	

SECTION 4 PLATFORMS

FIGURE 4-6. CONSOLE BOX ASSEMBLY (SEPTEMBER 1991 TO PRESENT) (CONTINUED)

FIG & ITEM #	PART NUMBER	DESCRIPTION	QTY.	REV.
27	4460244	Connector, Strain Relief (Prior to S/N 30520 Only)	1	
28	3300048	Locknut, Conduit	A/R	
29	0960238	Bushing	A/R	
30	4460051	Connector, Strain Relief	1	
31	3740049	Relay	6	
32	4761000	Lockwasher #10	7	
33	3311001	Nut #10-24NC	7	
34	3911012	Screw #10-24NC x 3/4"	1	
35 to 60	Not Used			
61	3640500	Rail, Mounting (Prior to S/N 30931)	1	
	3640970	Rail, Mounting (S/N 30931 to Present)	1	
62	3310601	Nut #6-32NC	2	
63	3910608	Screw, Round Head #6-32NC x 1/2"	2	
64	4750600	Flatwasher #6	2	
65	4760600	Lockwasher #6	2	
66	4460298	Block, Terminal	47	
67	4460300	Barrier, Terminal	1	
68	4460299	Stop, Terminal	2	
69	4460301	Marker, Terminal	1	
70	4460311	Bar, Buss - 5 Position	1	
71	4460305	Screw, Terminal	A/R	
72	4460306	Washer, Terminal	A/R	
73	4460307	Sleeve, Terminal	A/R	
74		Block, Contact Options:	1	
	4360282	Prior to S/N 47729		
	4360476	S/N 47729 to Present		
75	Not Used			
76	4070749	Shim, OEM Controller	1	
77	3900127	Screw, Round Head	1	
78	Not Used			
79	4460051	Connector, Strain Relief (Prior to S/N 30520 Only)	1	
80	0140026	Alarm, Intermittent	1	
81	4460386	Connector, Strain Relief (S/N 30520 to Present Only)	1	
82	3300147	Nut, Conduit (S/N 30520 to Present Only)	1	
83	0960905	Bushing (S/N 30520 to Present Only)	1	
84	4460071	Connector, Strain Relief (S/N 30520 to Present Only)	1	
85	1704260	Decal - EMS (S/N 47729 to Present)	1	
86 to 99	Not Used			
101		Lid Options:	1	
	3252145	110 HX September 1991 to May 1994		
	3252375	110 HX May 1994 to Present		
	3252145	100HX+10/110HXER September 1991 to May 1994		
	3252373	100HX+10/110HXER May 1994 to Present		
102		Switch, Toggle Options:	A/R	
	Not Required	110 HX	0	
	4360202	100HX+10/110HXER	1	
103		Harness - Footswitch Options:	A/R	
	4932118	Prior to S/N 28224	1	
	Not Required	S/N 28224 to Present	0	

SECTION 4 PLATFORMS

FIGURE 4-6. CONSOLE BOX ASSEMBLY (SEPTEMBER 1991 TO PRESENT) (CONTINUED)

FIG & ITEM #	PART NUMBER	DESCRIPTION	QTY.	REV.
104		Breaker, Circuit - 20 Amp Options:	A/R	
	4360209	Prior to S/N 28224	1	
	Not Required	S/N 28224 to Present	0	
105		Breaker, Circuit - 5 Amp	A/R	
	Not Required	Prior to S/N 28224	0	
	4360112	S/N 28224 to Present	2	
106		Breaker, Circuit - 10 Amp	A/R	
	Not Required	Prior to S/N 28224	0	
	4360069	S/N 28224 to Present	1	
107		Breaker, Circuit - 20 Amp	A/R	
	Not Required	Prior to S/N 28224	0	
	4360161	S/N 28224 to Present	1	
108		Bar, Buss - 2 Position	A/R	
	Not Required	Prior to S/N 28224	0	
	4460308	S/N 28224 to Present	1	
109		Cap, Circuit Breaker	A/R	
	Not Required	Prior to S/N 28224	0	
	3300396	S/N 28224 to Present	4	
		OPTIONAL INSTALLATIONS	Ref.	
201		Glow Plug/Choke Components		
	4360199	Switch, Toggle	1	
	4060087	Shield, Switch	1	
	3790012	O-Ring	1	
	1540002	Capacitor	1	
202	Not Used			
203		Lights Components		
	4360199	Switch, Toggle	1	
	4060087	Shield, Switch	1	
	3790012	O-Ring	1	
204	0251683	Engine Run Light Components		B
	2920027	Lamp, Indicator - Green	1	
	2920029	Bulb, Light	1	
	1702528	Decal - Engine Run	1	
205	0255274	Low Oil Pressure Light Components		4
	0255568	Engine Distress Light Components		—
	2920026	Lamp, Indicator - Red	1	
	2920029	Bulb, Light	1	
	3252074	Decal - Engine Distress	1	
	0254433	POWER CORD TO PLATFORM INSTALLATION	Ref.	2
301	Supply Locally	Cover, Weathershield	1	
302	Supply Locally	Receptacle, Electrical	1	
303	1060461	Cable, Electrical - 12/3	128ft/39m	
304	1700598	Decal - Ground (Not Shown)	2	
305	1700599	Decal - Neutral (Not Shown)	2	
306	Supply Locally	Plug, Terminal	1	

SECTION 4 PLATFORMS

**S
E
C
T
I
O
N

4

P
L
A
T
F
O
R
M
S**

FIGURE 4-6. CONSOLE BOX ASSEMBLY (SEPTEMBER 1991 TO PRESENT) (CONTINUED)

FIG & ITEM #	PART NUMBER	DESCRIPTION	QTY.	REV.
307	Supply Locally	Clamp, Cable (Not Shown)	1	

SECTION 4 PLATFORMS

FIGURE 4-6. CONSOLE BOX ASSEMBLY (SEPTEMBER 1991 TO PRESENT) (CONTINUED)

FIG & ITEM #	PART NUMBER	DESCRIPTION	QTY.	REV.

SECTION 4 PLATFORMS

FIGURE 4-7. CONTROLLER ASSEMBLIES - OEM

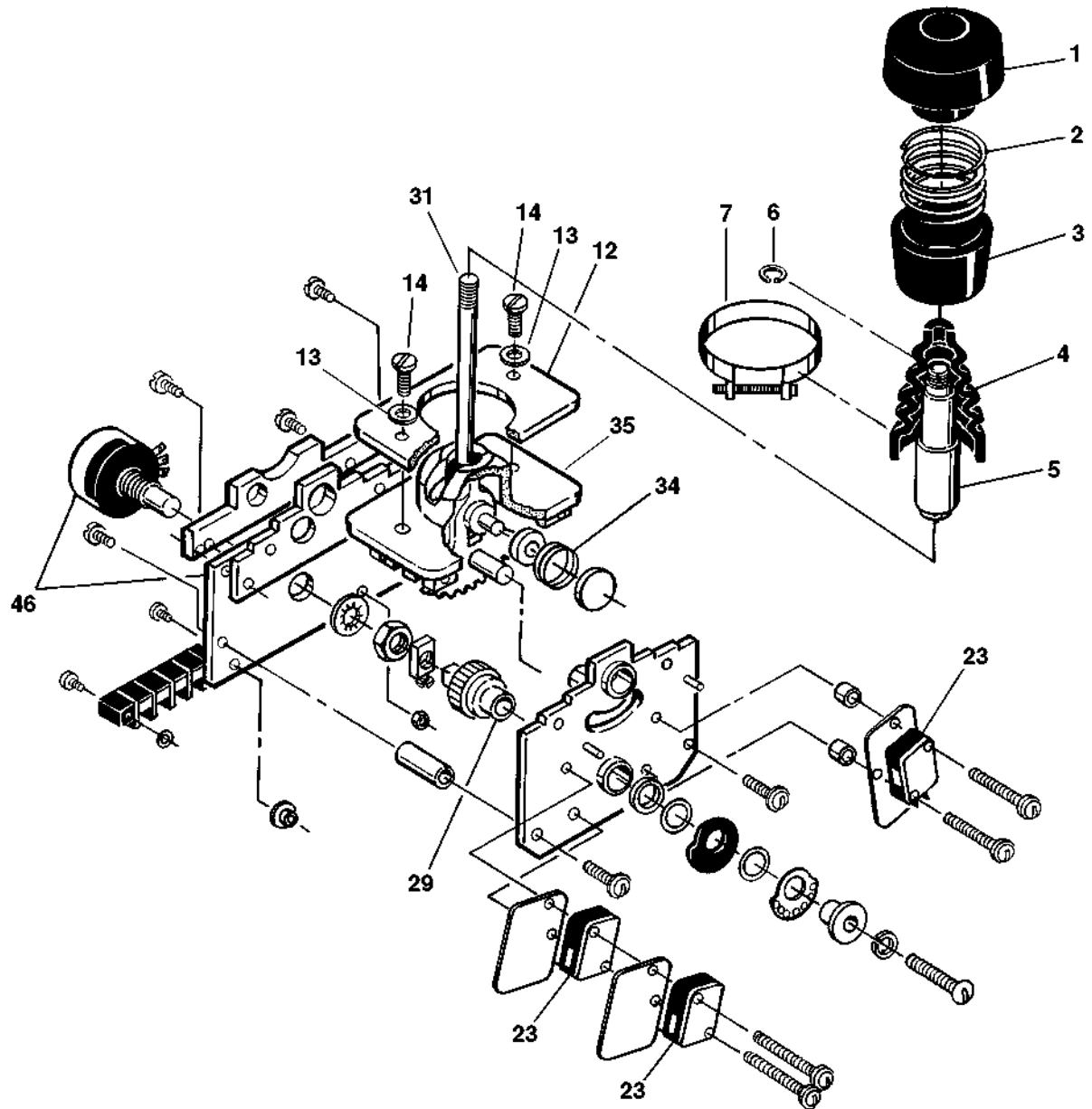

SECTION 4 PLATFORMS

FIGURE 4-7. CONTROLLER ASSEMBLIES - OEM

FIG & ITEM #	PART NUMBER	DESCRIPTION	QTY.	REV.
	1600092	CONTROLLER ASSEMBLY (PRIOR TO S/N 27148)	Ref.	B
	1600247	CONTROLLER ASSEMBLY (S/N 27148 TO PRESENT)	Ref.	—
1	7003927	Knob (Upper)	1	
2	7003928	Spring, Knob	1	
3	7003930	Knob (Lower)	1	
4	7003931	Boot	1	
5	7003932	Tube, Interlock	1	
6	7003937	Ring, Retaining	1	
7	7003938	Clamp, Boot	1	
8 to 11	Not Used			
12	7003933	Gasket	1	
13	7003941	Washer, Nylon	2	
14	7003940	Screw	2	
15 to 22	Not Used			
23	7003961	Microswitch	3	
24 to 28	Not Used			
29	7003935	Gear, Slave	1	
30	Not Used			
31	7003939	Shaft	1	
32 to 33	Not Used			
34	7003936	Spring, Return	1	
35	7003950	Plate, Zinc Retainer	1	
36 to 45	Not Used			
46	7003947	PC Board Assembly (Includes Potentiometer) (1600092)	1	
	7019120	PC Board Assembly (1600247) Note: Recommend replacing complete controller due to cost comparison.		

SECTION 4 PLATFORMS

FIGURE 4-8. OPTIONAL COMMON PLATFORM MOUNTED COMPONENTS

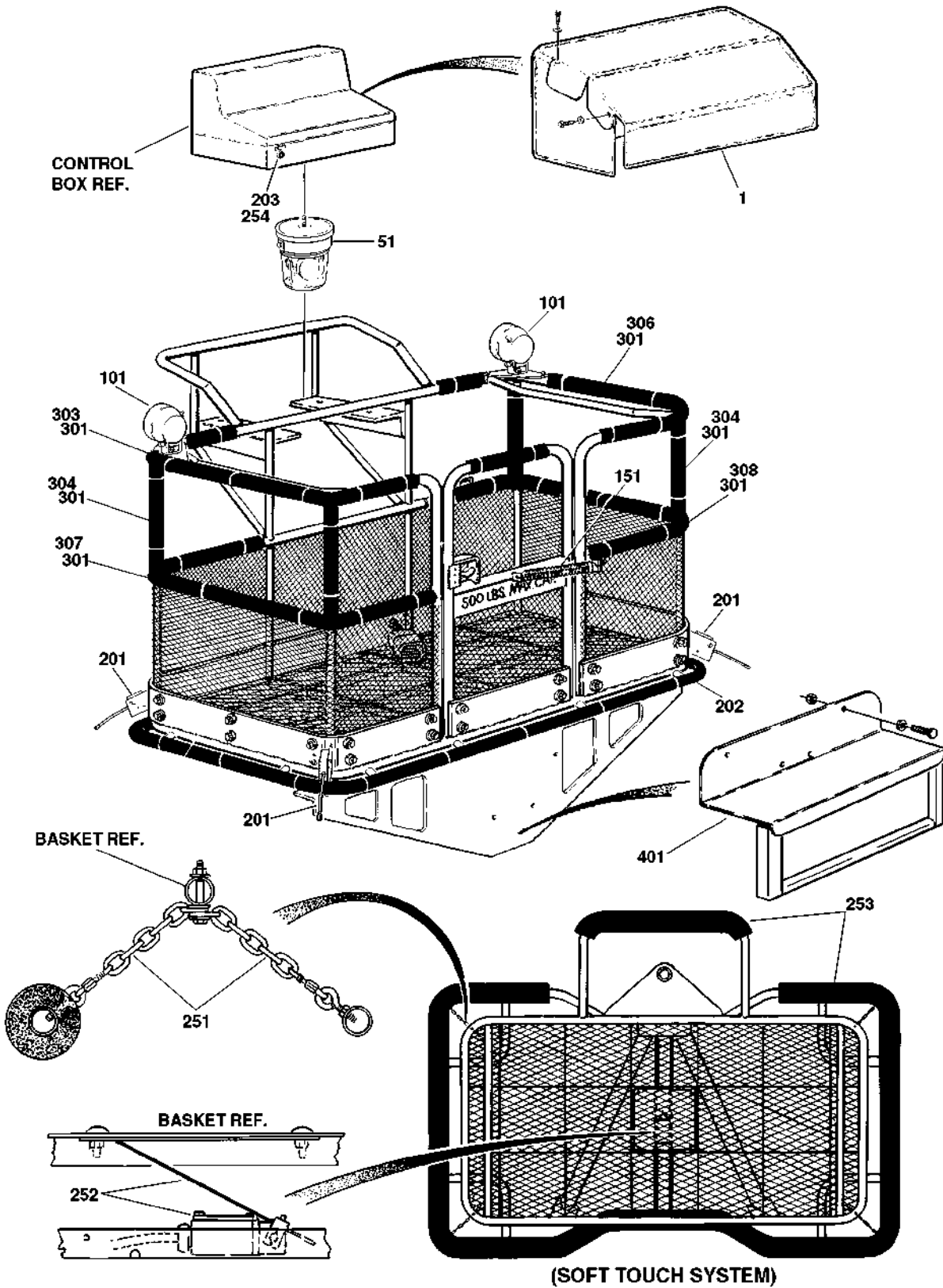

SECTION 4 PLATFORMS

FIGURE 4-8. OPTIONAL COMMON PLATFORM MOUNTED COMPONENTS

FIG & ITEM #	PART NUMBER	DESCRIPTION	QTY.	REV.
	0239259	CONSOLE BOX COVER INSTALLATIONS (PRIOR TO SEPTEMBER 1990)	Ref.	—
	0252054/0231203	CONSOLE BOX COVER INSTALLATIONS (SEPTEMBER 1990 TO PRESENT) Note: See Section 10 for Metal Console Covers.	Ref.	2/2
1		Cover Options:	1	
	1670482	Cover (Prior to September 1990)		
	1670607	Cover (Black/September 1990 to Present)		
	1670526	Cover (Yellow/September 1990 to Present)		
2	Not Used			
3	Not Used			
4	Not Used			
		BEACON LIGHT OPTIONS:	Ref.	
51	0252211/0252210	Beacon Mounted Under Console (September 1991 to Present)	A/R	3/3
	2920009	Beacon (Red)		
	2920018	Beacon (Amber)		
52	Not Used			
53	Not Used			
54	Not Used			
55	2540016	Grommet (Not Shown)	1	
	2900068	WORKLIGHT OPTIONS (PRIOR TO NOVEMBER 1992)	Ref.	F
	0253686	WORKLIGHT OPTIONS (NOVEMBER 1992 TO MAY 1995)	Ref.	—
	0253987	WORKLIGHT OPTIONS (MAY 1995 TO PRESENT)	Ref.	4
	0254748	WORKLIGHT OPTIONS WITH PADDED PLATFORM	Ref.	2
101	2920013	Floodlight (Prior to November 1992)	2	
	2920111	Halogen Light (November 1992 to Present) (Uses P/N 3536089 Mounting Plate)	2	
	0250143	SELF-CLOSING GATE INSTALLATION	Ref.	A
151	4160028	Spring	1	
	0900232	Bracket (Door Mounted)	1	
	0901056	Bracket (Platform Mounted)	1	
	4220007	Stop, Door	1	
152	Not Used			
153	Not Used			

SECTION 4 PLATFORMS

FIGURE 4-8. OPTIONAL COMMON PLATFORM MOUNTED COMPONENTS (CONTINUED)

FIG & ITEM #	PART NUMBER	DESCRIPTION	QTY.	REV.
	1281083	PLATFORM BUMPERS INSTALLATION (WELDED-ON TYPE)	Ref.	I
	0250689	3' x 5' STANDARD PLATFORM (100HX/110HX)	Ref.	C
	0250071	3' x 6' STANDARD PLATFORM (100HX/110HX)	Ref.	C
	0239743	3' x 8' STANDARD PLATFORM (100HX/110HX)	Ref.	D
	0251349	3' x 5' EXTEND-A-REACH PLATFORM (110HXER/100HX+10) (PRIOR TO MAY 1992)	Ref.	
	0251350	3' x 6' EXTEND-A-REACH PLATFORM (110HXER/100HX+10) (PRIOR TO MAY 1992)	Ref.	
	0250919	3' x 5' LOW MOUNT PLATFORM (110HXER/100HX+10) (MAY 1992 TO PRESENT)	Ref.	
	0253426	3' X 6' LOW MOUNT PLATFORM (110HXER/100HX+10) (MAY 1992 TO PRESENT)	Ref.	A
	0252902	3' X 8' LOW MOUNT PLATFORM (110HXER/100HX+10) (MAY 1992 TO PRESENT)	Ref.	A
201	4360215	Switch, Proximity	4	
	4460521	Connector, Strain Relief	4	
202	0940038	Padding, Bumper	A/R	
203	4360274	Switch, Push Button (Override)	1	
	3251596	Nameplate - Override	1	
	3740049	Relay (Not Shown)	1	
	1282197	PLATFORM BUMPERS INSTALLATION - SOFT TOUCH SYSTEM (CHAIN MOUNTED TYPE)	Ref.	D
	0254463	3' x 5' LOW MOUNT PLATFORM (110HXER/100HX+10)	Ref.	6
	0254464	3' x 6' LOW MOUNT PLATFORM (110HXER/100HX+10)	Ref.	7
	0254465	3' x 8' LOW MOUNT PLATFORM (110HXER/100HX+10)	Ref.	7
251	0630440	Eyebolt	8	
	3010088	Link, Quick	8	
	1260136	Chain	A/R	
252	4360057	Switch, Limit	1	
	0200048	Arm, Actuator	1	
253	0940038	Padding (Bottom Rail)	A/R	
	1670663	Padding (Rail Behind Console Box) (Prior to S/N 44770)	1	
	1670664	Padding (LH Top Rail - 36" x 60" Platform)	1	
	1670715	Padding (LH Top Rail - 36" x 72" Platform)	1	
	1670720	Padding (LH Top Rail - 36" x 96" Platform)	1	
	1670665	Padding (Vertical Rails)	4	
	1670666	Padding (Gate)	1	
	1670667	Padding (RH Top Rail - 36" x 60" Platform)	1	
	1670716	Padding (RH Top Rail - 36" x 72" Platform)	1	
	1670721	Padding (RH Top Rail - 36" x 96" Platform)	1	
	1670671	Padding (LH Mid Rail - 36" x 60" Platform)	1	
	1670717	Padding (LH Mid Rail - 36" x 72" Platform)	1	

SECTION 4 PLATFORMS

FIGURE 4-8. OPTIONAL COMMON PLATFORM MOUNTED COMPONENTS (CONTINUED)

FIG & ITEM #	PART NUMBER	DESCRIPTION	QTY.	REV.
	1670722	Padding (LH Mid Rail - 36" x 96" Platform)	1	
	1670672	Padding (RH Mid Rail - 36" x 60" Platform)	1	
	1670718	Padding (RH Mid Rail - 36" x 72" Platform)	1	
	1670723	Padding (RH Mid Rail - 36" x 96" Platform)	1	
	1670673	Padding (Bumper Rail - 36" x 60" Platform)	1	
	1670719	Padding (Bumper Rail - 36" x 72" Platform)	1	
	1670724	Padding (Bumper Rail - 36" x 96" Platform)	1	
254	4360274	Switch, Push Button	1	
	3252238	Decal - Soft Touch System	1	
255	1060341	Cable, Electrical 16-2 Options (Not Shown) (S/N 36200 to Present):	A/R	
		3' x 5' Platform	14ft/4.3m	
		3' x 6' Platform	12ft/3.7m	
		3' x 8' Platform	12ft/3.7m	
	0258917	PLATFORM - 3' X 8' BUMPER PADDING INSTALLATION (S/N 39684 TO PRESENT)	Ref.	2
301	0940038	Padding, Bumper	38ft/11.6m	
302	Not Used			
303	1670720	Cover, (LH Top Rail)	1	
304	1670665	Cover, (Vertical Rails)	4	
305	1670666	Cover, (Gate Top Rail)	1	
306	1670721	Cover, (RH Top Rail)	1	
307	1670722	Cover, (LH Mid Rail)	1	
308	1670723	Cover, (RH Mid Rail)	1	
	0251059	ACCESS STEP INSTALLATION	Ref.	2/A
401	4844395	Step Weldment	1	
402	Not Used			

SECTION 4 PLATFORMS

SECTION 4 PLATFORMS

FIGURE 4-8. OPTIONAL COMMON PLATFORM MOUNTED COMPONENTS (CONTINUED)

FIG & ITEM #	PART NUMBER	DESCRIPTION	QTY.	REV.

SECTION 5 CYLINDER

TABLE OF CONTENTS		
FIGURE	DESCRIPTION	PAGE
5-1	AXLE EXTENSION CYLINDER ASSEMBLY	5-2
5-2	AXLE LIFT CYLINDER ASSEMBLY	5-4
5-3	LEVEL CYLINDER ASSEMBLY (Model 100HX & 110HX Built Prior To May 1992)	5-6
5-4	LEVEL CYLINDER ASSEMBLY (Model 100HX & 110HX Built May 1992 to Present)	5-8
5-5	LEVEL CYLINDER ASSEMBLY (Model 100HX+10 & 110HXER Built Prior To May 1992)	5-10
5-6	LEVEL CYLINDER ASSEMBLY (Model 100HX+10 & 110HXER Built May 1992 to Present) ..	5-12
5-7	LIFT CYLINDER ASSEMBLIES - BOOM (Prior To May 1992)	5-14
5-8	LIFT CYLINDER ASSEMBLIES - BOOM (May 1992 to Present)	5-16
5-9	LIFT CYLINDER ASSEMBLIES - BOOM (May 1992 to Present)	5-18
5-10	LIFT CYLINDER ASSEMBLIES - EXTEND-A-REACH (100HX+10 & 110HXER Only)	5-20
5-11	MASTER CYLINDER ASSEMBLY	5-22
5-12	STEER CYLINDER ASSEMBLY	5-24
5-13	TELESCOPE CYLINDER ASSEMBLIES	5-26
5-14	CYLINDER BELLOWS INSTALLATION	5-30

SECTION 5 CYLINDER

FIGURE 5-1. AXLE EXTENSION CYLINDER ASSEMBLY

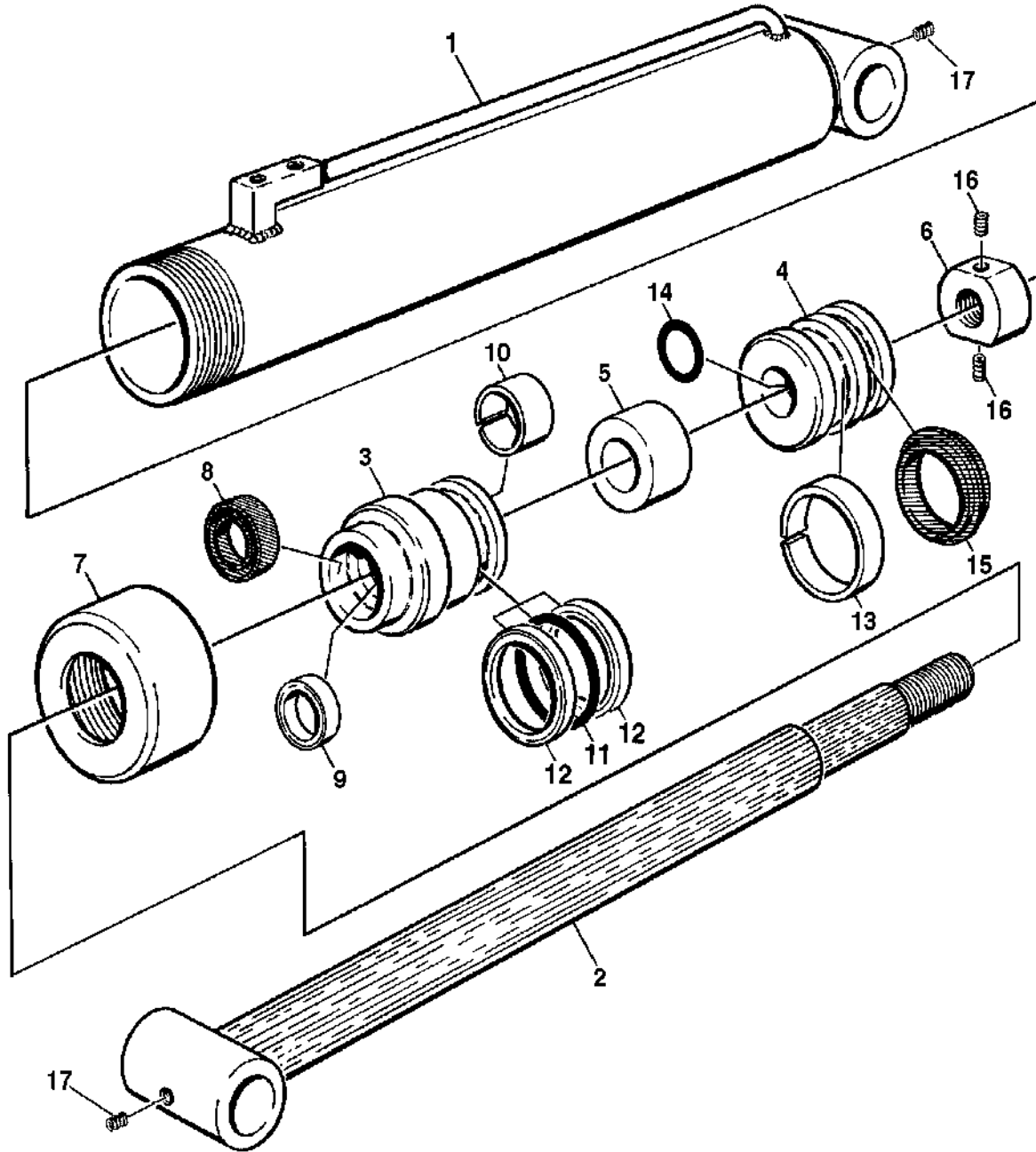

SECTION 5 CYLINDER

FIGURE 5-1. AXLE EXTENSION CYLINDER ASSEMBLY

FIG & ITEM #	PART NUMBER	DESCRIPTION	QTY.	REV.
	1681964	AXLE EXTENSION CYLINDER ASSEMBLY	Ref.	C
1	1681965	Barrel Weldment	1	
2	1681967	Rod Weldment	1	
3	1680892	Head	1	
4	3480120	Piston	1	
5	4564046	Spacer, Tube	1	
6		Nut Options:	1	
	3300187	Prior to February 1991		
	3300273	February 1991 to Present (Hex Style) (Not Shown)		
7	1120179	Retainer	1	
8	Kit	Wiper, Rod	1	
9	Kit	Seal, Rod	1	
10	Kit	Ring, Wear	1	
11	Kit	O-Ring	1	
12	Kit	Ring, Back-Up	2	
13	Kit	Ring, Wear	1	
14	Kit	O-Ring	1	
15	Kit	Seal, Piston	1	
16		Setscrew Options:	A/R	
	3951403	Setscrew 1/4"-20NC x 3/8" (Prior to February 1991)	2	
	3900170	Setscrew 3/8"-16NC x 3/8" (February 1991 to Present)	1	
17	2200201	Plug, Pipe 1/8" NPT	2	
18	0100011	Loctite #242 (Not Shown)	A/R	
19	Not Used			
20	0100035	Loctite #222 (Not Shown)	A/R	
21	0100038	Primer, Locking (Not Shown)	A/R	

	2900381	Seal Kit (Includes Items 8-15)	1	

SECTION 5 CYLINDER

FIGURE 5-2. AXLE LIFT CYLINDER ASSEMBLY

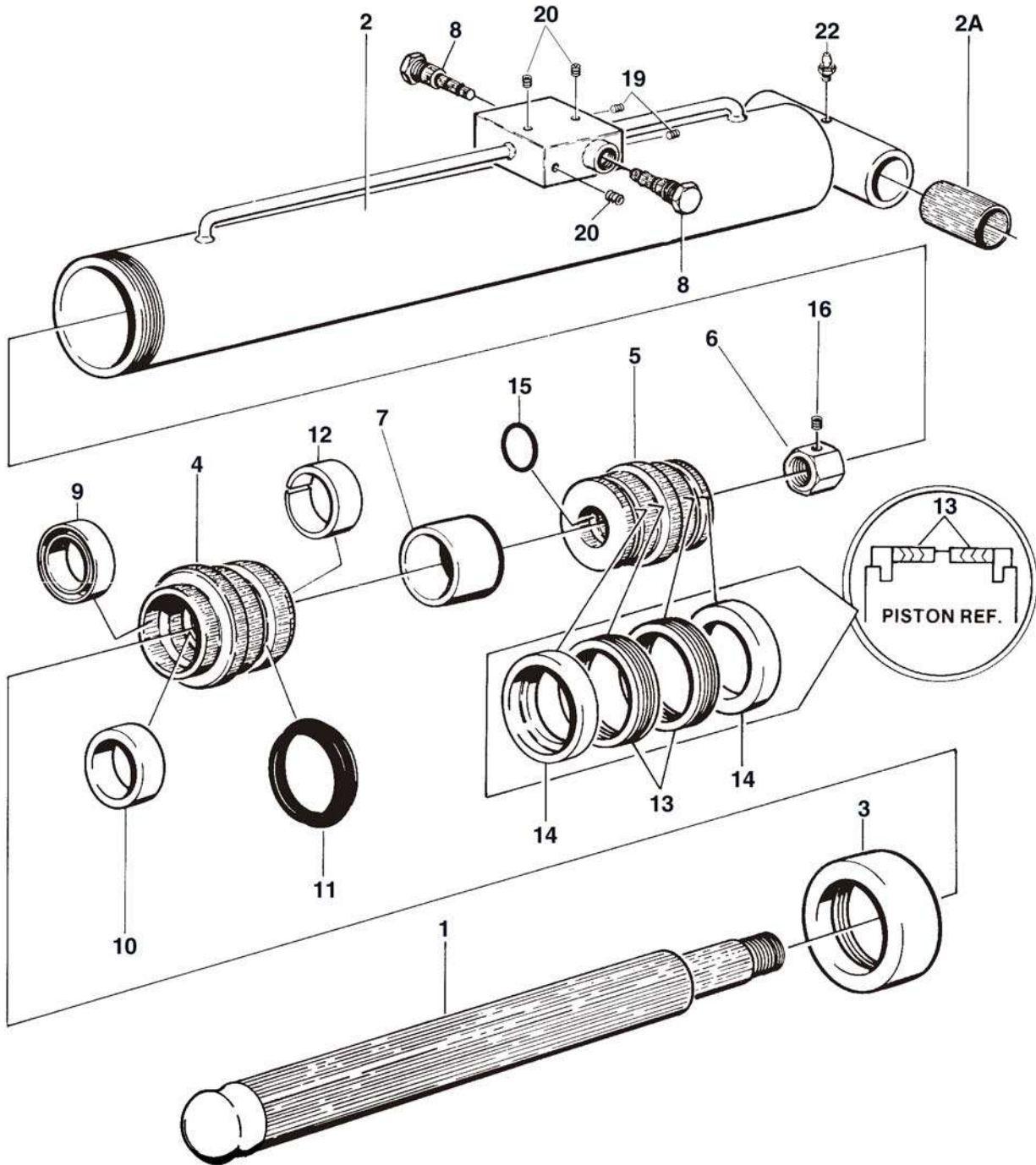

SECTION 5 CYLINDER

FIGURE 5-2. AXLE LIFT CYLINDER ASSEMBLY

FIG & ITEM #	PART NUMBER	DESCRIPTION	QTY.	REV.
		AXLE LIFT CYLINDER ASSEMBLIES	Ref.	
	1681991	Prior To S/N 39439	Ref.	B
	1683596	S/N 39439 To Present	Ref.	2
1		Rod Assembly Options:	1	
	1681992	Prior to S/N 39439		
	1683597	S/N 39439 to Present		
2	1681963	Barrel Assembly	1	
2A	0960946	Bushing, Bronze	2	
3	1120336	Cap	1	
	0100035	Loctite #222	A/R	
4	1681843	Head	1	
5	3480102	Piston	1	
6	3300281	Nut, Special	1	
	0100011	Loctite #242	A/R	
	0100038	Primer	A/R	
7	4564128	Spacer	1	
8	4640509	Valve	2	
9	Kit	Ring, Wiper	1	
10	Kit	Seal	1	
11	Kit	T-Seal	1	
12	Kit	Ring, Wear	1	
13	Kit	Seal	2	
14	Kit	Ring, Guidelock	2	
15	Kit	O-Ring	1	
16	3900170	Setscrew 3/8"-16NC x 3/8"	1	
17	Not Used			
18	Not Used			
19		Plug 1/4" Options:	2	
	2200202	Prior to S/N 39439		
	2200222	S/N 39439 to Present		
	0100020	Loctite	A/R	
20		Plug 1/8" Options:	4	
	2200201	Prior to S/N 39439		
	2200221	S/N 39439 to Present		
	0100020	Loctite	A/R	
21	Not Used			
22	2160002	Fitting, Grease	1	
	2901102	Seal Kit (Includes Items 9 - 15)	1	

SECTION 5 CYLINDER

FIGURE 5-3. PLATFORM LEVEL CYLINDER ASSEMBLY (100HX & 110HX BUILT PRIOR TO MAY 1992)

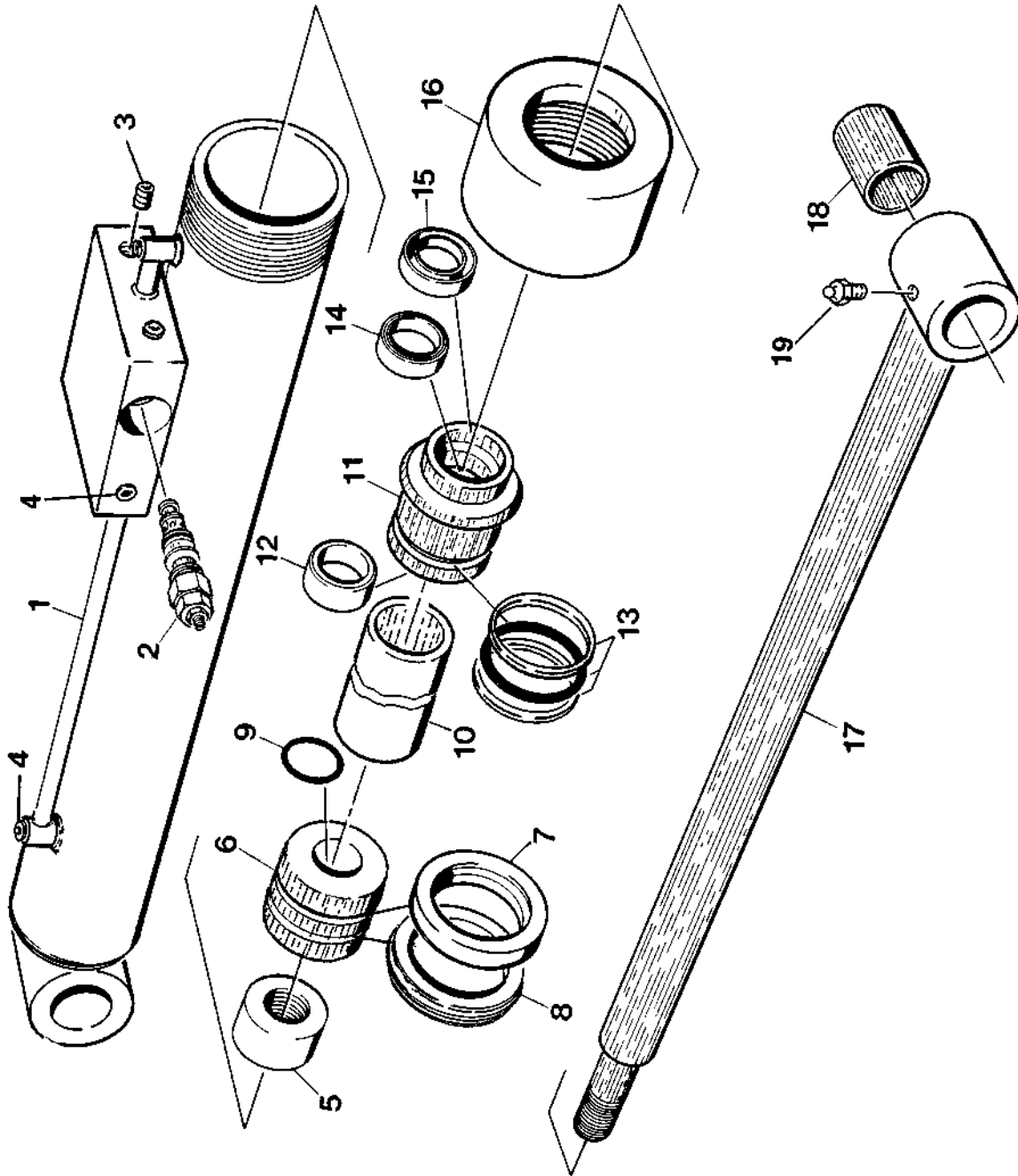

SECTION 5 CYLINDER

FIGURE 5-3. PLATFORM LEVEL CYLINDER ASSEMBLY (100HX & 110HX BUILT PRIOR TO MAY 1992)

FIG & ITEM #	PART NUMBER	DESCRIPTION	QTY.	REV.
	1681973	PLATFORM LEVEL CYLINDER ASSEMBLY	Ref.	E
1	1681976	Barrel Assembly	1	
2	4640509	Valve, Cartridge	2	
	2900792	Seal Kit - 4640509 Valve (1 Per Cartridge)	2	
3	2200202	Plug, Pipe	2	
	0100020	Sealant, Pipe	A/R	
4	2200201	Plug, Pipe	6	
	0100020	Sealant, Pipe	A/R	
5		Nut Options:	1	
	3300257	Nut, Standard Production (Without Setscrew)		
	3300301	Nut, Hex Style Replacement (Requires Setscrew)		
	3900170	Setscrew 3/8"-16NC x 3/8" (Not Shown)	1	
	0100011	Loctite #242	A/R	
	0100038	Primer, Locking	A/R	
6	3480120	Piston	1	
7	Kit	Ring, Wear	1	
8	Kit	Seal, Piston	2	
9	Kit	O-Ring	1	
10	4564057	Spacer	1	
11	1680892	Head	1	
12	Kit	Ring, Wear	1	
13	Kit	Ring, Back-up	2	
	Kit	O-Ring	1	
14	Kit	Seal, Rod	1	
15	Kit	Seal, Wiper	1	
16	1120179	Retainer	1	
	0100035	Loctite #222	A/R	
17	1681974	Rod Assembly	1	
18	0960097	Bushing	1	
19	2160002	Fitting, Grease	2	
	2900381	Seal Kit - 1681973 Cylinder (Includes Items 7-9 & 12-15)	1	

SECTION 5 CYLINDER

FIGURE 5-4. LEVEL CYLINDER ASSEMBLY (100HX & 110HX)

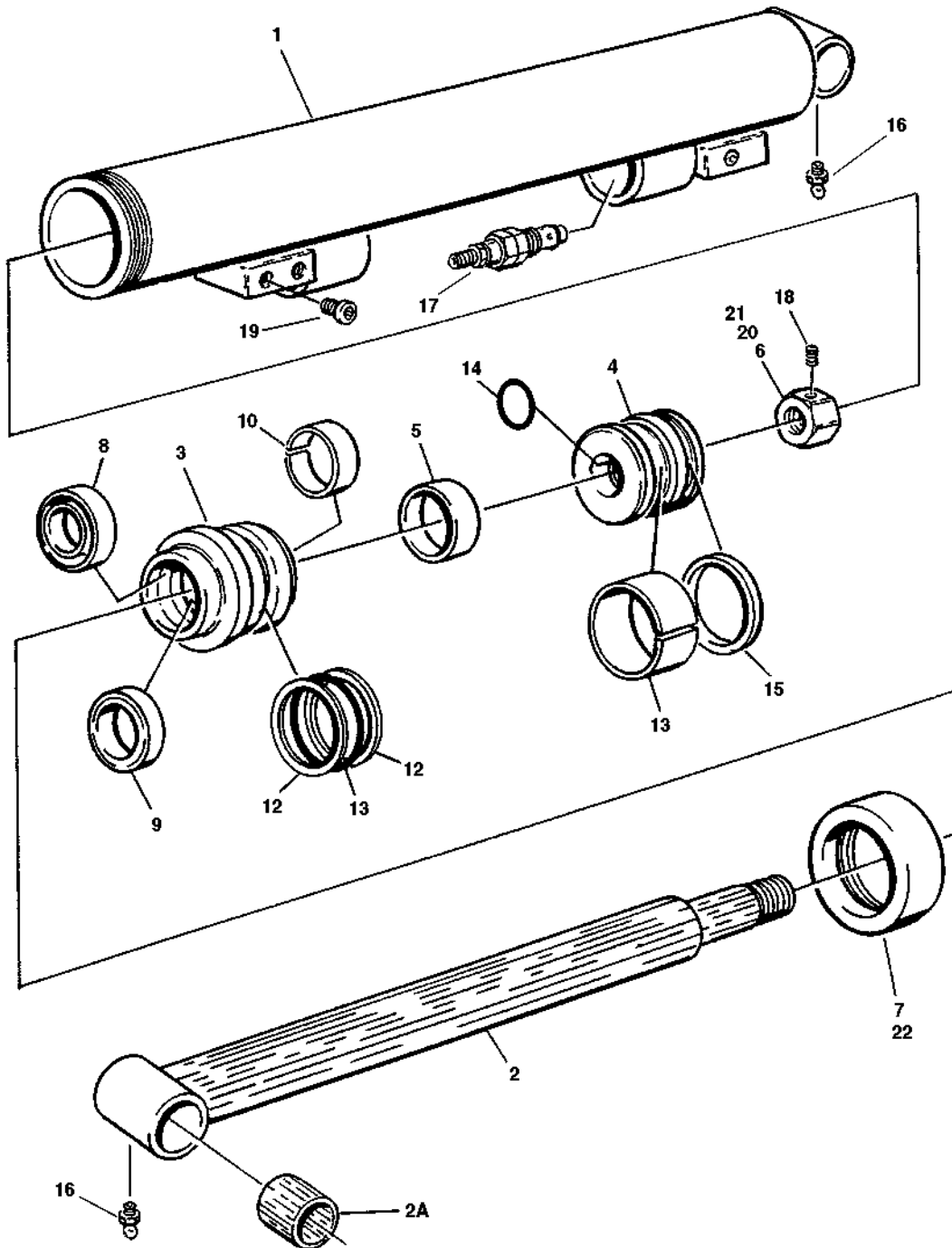

SECTION 5 CYLINDER

FIGURE 5-4. LEVEL CYLINDER ASSEMBLY (100HX & 110HX)

FIG & ITEM #	PART NUMBER	DESCRIPTION	QTY.	REV.
		PLATFORM SLAVE LEVEL CYLINDER ASSEMBLY	Ref.	
		OPTIONS:		
	1682590	May 1992 To S/N 33111	Ref.	C
	1683536	S/N 33111 To Present	Ref.	1/A
1		Barrel Assembly Options:	1	
	1682591	May 1992 to S/N 33111		
	1683535	S/N 33111 to Present		
2	1681974	Rod Assembly	1	
2A	0960097	Bushing	1	
3	1680892	Head	1	
4	3480120	Piston	1	
5	4564057	Spacer	1	
6	3300308	Nut	1	
7	1120179	Retainer	1	
8	Kit	Seal, Wiper	1	
9	Kit	Seal, Rod	1	
10	Kit	Ring, Wear	1	
11	Kit	O-Ring	1	
12	Kit	Ring, Back-up	2	
13	Kit	Ring, Wear	1	
14	Kit	O-Ring	1	
15	Kit	Seal, Piston	1	
16	2160002	Fitting, Grease	2	
17	4640634	Valve, Cartridge - Holding	2	
	2900770	Seal Kit - 4640634 Valve (1 Per Assembly)	1	
18	3900170	Setscrew 2/8"-16NC x 3/8"	1	
19	2220885	Plug, Socket Head #6	2	
20	0100011	Loctite #242	A/R	
21	0100038	Primer, Locking	A/R	
22	0100035	Loctite #222	A/R	

	2900381	Seal Kit - 1682590 Cylinder (Includes Items 8-14)	1	

SECTION 5 CYLINDER

FIGURE 5-5. PLATFORM LEVEL CYLINDER ASSEMBLY (100HX+10 & 110HXER BUILT PRIOR TO MAY 1992)

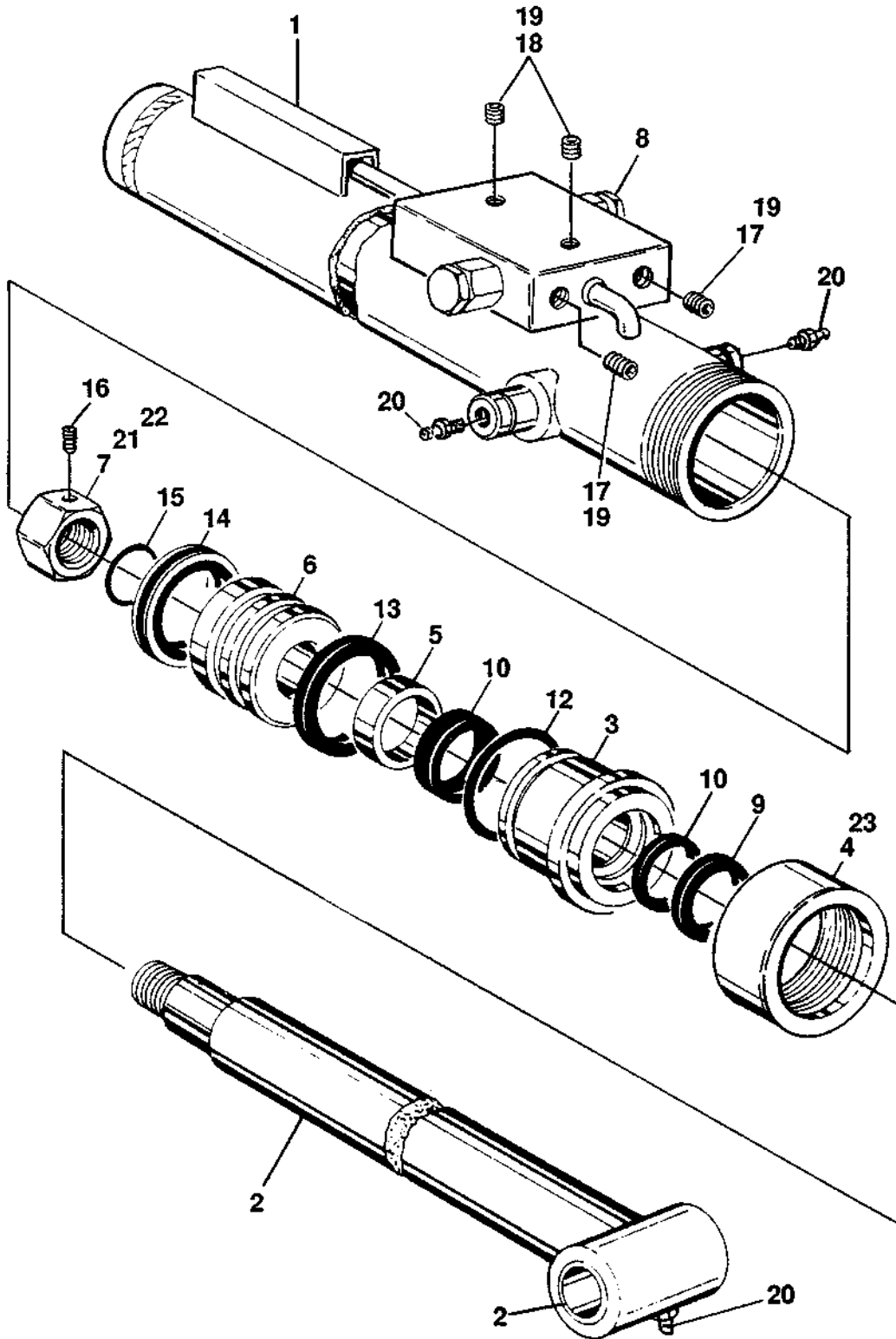

SECTION 5 CYLINDER

FIGURE 5-5. PLATFORM LEVEL CYLINDER ASSEMBLY (100HX+10 & 110HXER BUILT PRIOR TO MAY 1992)

FIG & ITEM #	PART NUMBER	DESCRIPTION	QTY.	REV.
		PLATFORM LEVEL CYLINDER ASSEMBLY OPTIONS:	Ref.	
	1681791	Prior To February 1991	Ref.	F
	1682459	February 1991 To May 1992	Ref.	2
1		Barrel Assembly Options:	1	
	1681796	Prior To February 1991	1	
	1682460	February 1991 To May 1992	1	
2	1681797	Rod Assembly	1	
	0961182	Bushing, Bronze	2	
3	1681792	Head	1	
4	1120305	Retainer	1	
5	4563657	Spacer	1	
6	3480124	Piston	1	
7		Nut Options:	1	
	3300234	Nut (Prior to January 1991)		
	3300276	Nut, Hex (January 1991 to May 1992)		
8	4640509	Valve, Cartridge - Holding	2	
	2900792	Seal Kit - 4640509 Valve (1 Per Cartridge)	2	
9	Kit	Seal, Wiper	1	
10	Kit	Seal, Rod	1	
11	Kit	Ring, Wear	1	
12	Kit	O-Ring	1	
13	Kit	Ring, Wear	1	
14	Kit	T-Seal	1	
15	Kit	O-Ring	1	
16		Setscrew Options:	A/R	
	3951403	Setscrew 1/4"-20NC x 3/8"	2	
	3900170	Setscrew 3/8"-16NC x 3/8"	1	
17		Plug, Pipe 1/4" Options:	2	
	2200213	Prior to S/N 39439		
	2200233	S/N 39439 to Present		
18		Plug, Pipe 1/8" Options:	2	
	2200201	Prior to S/N 39439		
	2200221	S/N 39439 to Present		
19	0100020	Sealant, Thread	A/R	
20	2160002	Fitting, Grease	3	
21	0100011	Loctite #242	A/R	
22	0100038	Primer, Locking	A/R	
23	0100035	Loctite #222	A/R	
	2900394	Seal Kit - Cylinder (Includes Items 9-15)	1	

SECTION 5 CYLINDER

FIGURE 5-6. PLATFORM LEVEL CYLINDER ASSEMBLY (100HX+10 & 110HXER)

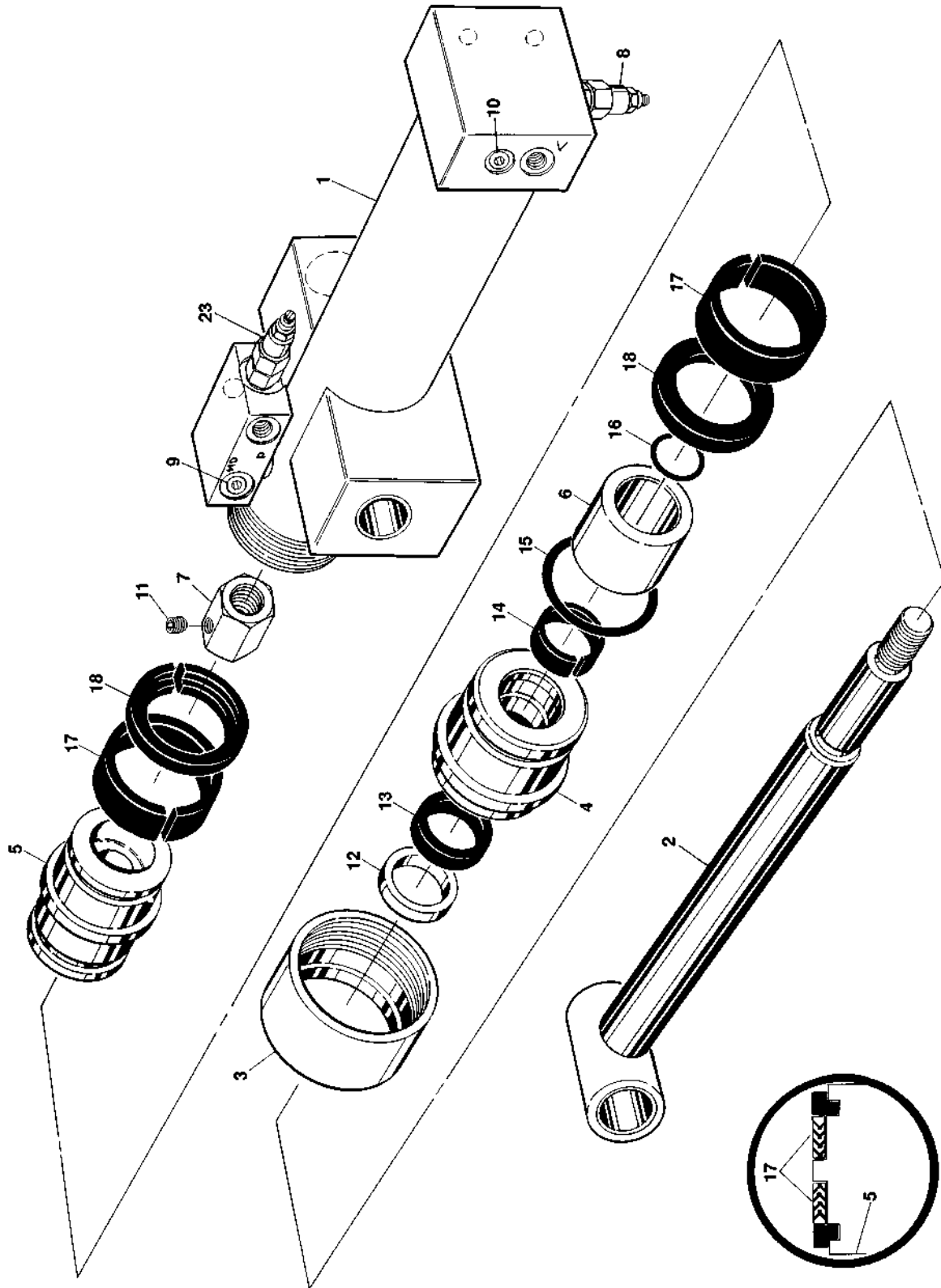

SECTION 5 CYLINDER

FIGURE 5-6. PLATFORM LEVEL CYLINDER ASSEMBLY (100HX+10 & 110HXER)

FIG & ITEM #	PART NUMBER	DESCRIPTION	QTY.	REV.
		PLATFORM LEVEL CYLINDER ASSEMBLY OPTIONS:	Ref.	
	1682753	May 1992 To S/N 29913	Ref.	F
	1683493	S/N 29913 To Present	Ref.	A
1	1682754	Barrel Weldment	1	
	0961595	Bushing, Bronze	2	
2	1682755	Rod Weldment	1	
	0961182	Bushing, Oilite	2	
3	1120305	Retainer	1	
4	1681792	Head	1	
5	3480167	Piston	1	
6	4565913	Spacer	1	
7	3300279	Nut	1	
8	4640634	Cartridge, Holding Valve	1	
	2900770	Seal Kit - 4640634 Valve	1	
9	2220885	Plug 3/8"	1	
10	2220883	Plug 1/4"	2	
11	3900170	Setscrew 3/8"-16NC x 3/8"	1	
12	Kit	Wiper, Rod	1	
13	Kit	Seal, Rod	1	
14	Kit	Ring, Wear	1	
15	Kit	O-Ring	1	
16	Kit	O-Ring	1	
17	Kit	Ring, Guide	2	
18	Kit	Ring, Lock	2	
19 to 22	Not Used			
23		Cartridge, Holding Valve Options:		
	4640634	Cartridge, Holding Valve (May 1992 to S/N 29913)	1	
	2900770	Seal Kit - 4640634 Valve	1	
	4640996	Cartridge, Holding Valve (S/N 29913 to Present)	1	
	Not Available	Seal Kit - 4640996 Valve	1	

	0100038	Primer, Loctite	A/R	
	0100011	Loctite #242	A/R	
	0100035	Loctite #222	A/R	

	2901206	Seal Kit (Includes Items 12-18)	1	

SECTION 5 CYLINDER

FIGURE 5-7. LIFT CYLINDER ASSEMBLY - BOOM (PRIOR TO MAY 1992)

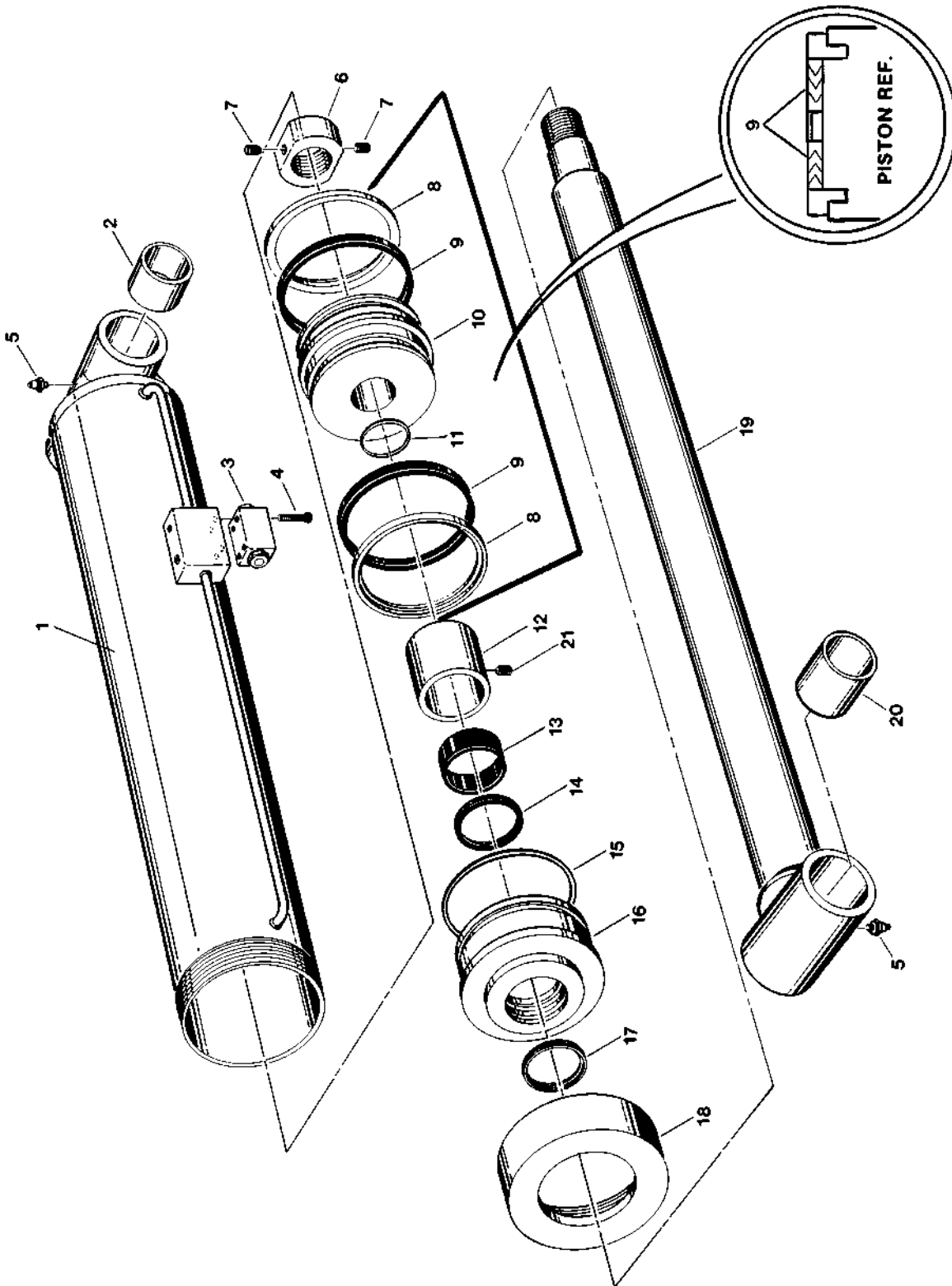

SECTION 5 CYLINDER

FIGURE 5-7. LIFT CYLINDER ASSEMBLY - BOOM (PRIOR TO MAY 1992)

FIG & ITEM #	PART NUMBER	DESCRIPTION	QTY.	REV.
	1682034	LIFT CYLINDER ASSEMBLY	Ref.	B
1	1682035	Barrel Assembly (Includes Item 2)	1	
2	0961082	Bushing, Bronze	2	
3	4640181	Valve, Block	1	
	3900138	Orifice (Located in Valve Block)	1	
4	3931440	Capscrew, Socket Head 1/4"-20NC x 2 1/2"	4	
5	2160002	Fitting, Grease	2	
6		Nut Options:	1	
	3300192	Nut, Special (Prior to January 1991)		
	3300297	Nut, Hex (January 1991 to Present)		
	0100011	Loctite #242 (Not Shown)	A/R	
	0100038	Primer, Locking (Not Shown)	A/R	
7		Setscrew Options:	A/R	
	3900136	Setscrew (Prior to January 1991)	2	
	3900171	Setscrew (January 1991 to Present)	1	
8	Kit	Ring, Lock	2	
9	Kit	Seal, Piston	2	
10	3480104	Piston	1	
11	Kit	O-Ring	1	
12	4564142	Spacer	1	
13	Kit	Ring, Wear	1	
14	Kit	Seal, Rod	2	
15	Kit	O-Ring	1	
16	1681298	Head	1	
17	Kit	Wiper	1	
18	1120238	Cap, Retainer	1	
	0100035	Loctite #222 (Not Shown)	A/R	
19	1681835	Rod Assembly (Includes Item 20)	1	
20	0961082	Bushing, Bronze	2	
21		Setscrew Options:	A/R	
	3900136	Setscrew 1/2"-13NC x 1/2" (Prior to January 1991)	2	
	3951404	Setscrew 1/4"-20NC x 1/2" (January 1991 to Present)	1	
	0100011	Loctite #242 (Not Shown)	A/R	
	2900338	Seal Kit (Includes Items 8,9,11,13,14,15 and 17)	1	

SECTION 5 CYLINDER

FIGURE 5-8. LIFT CYLINDER ASSEMBLY - BOOM (MAY 1992 TO PRESENT)

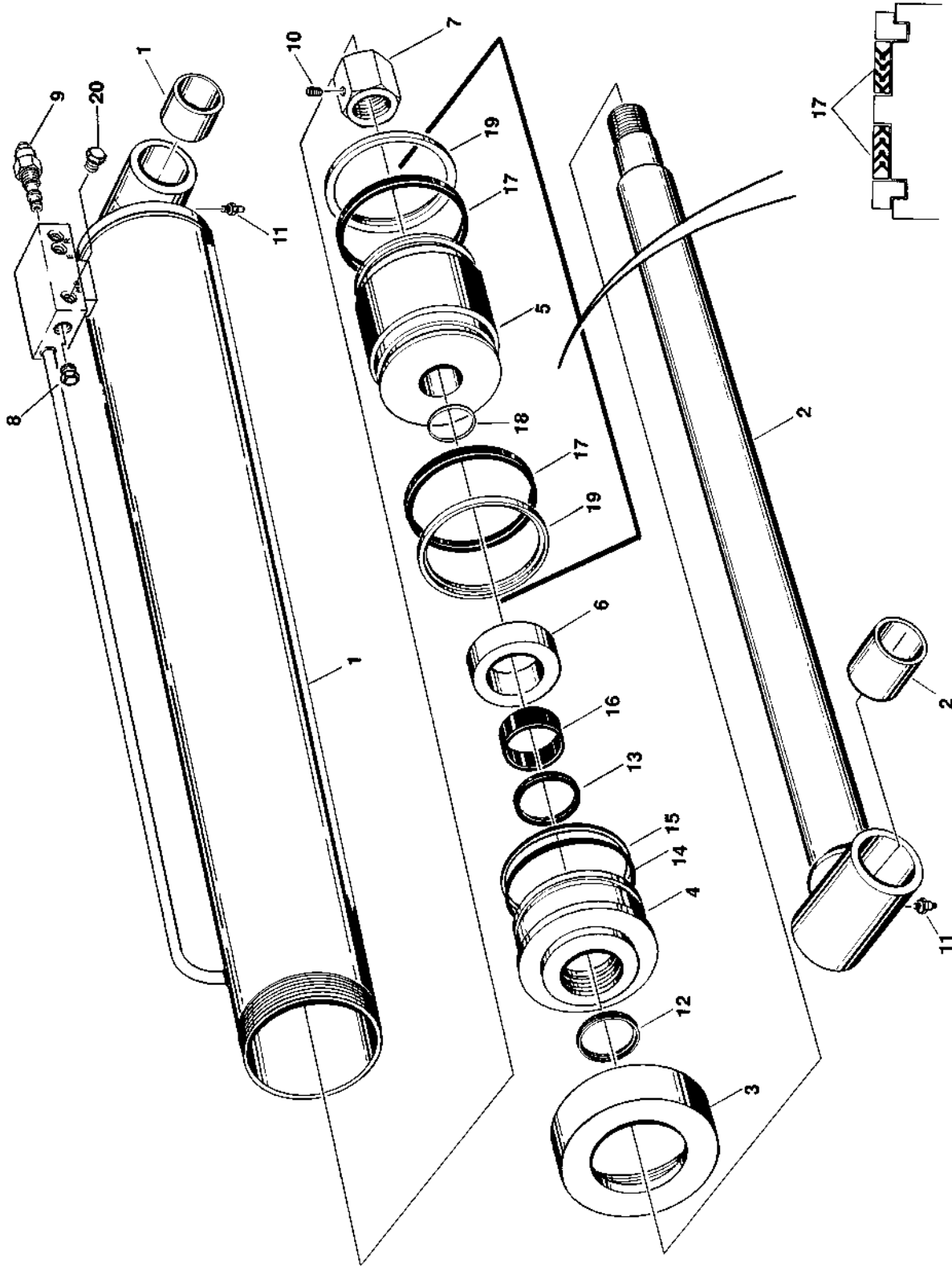

SECTION 5 CYLINDER

FIGURE 5-8. LIFT CYLINDER ASSEMBLY - BOOM (MAY 1992 TO PRESENT)

FIG & ITEM #	PART NUMBER	DESCRIPTION	QTY.	REV.
	1682630	LIFT CYLINDER ASSEMBLY - BOOM (MAY 1992 TO PRESENT)	Ref.	B
1	1682631	Barrel Weldment	1	
	0960509	Bushing, Bronze	2	
2	1682633	Rod Weldment	1	
	0961082	Bushing, Bronze	2	
3	1120363	Retainer	1	
4	1682118	Head	1	
5	3480162	Piston	1	
6	4565652	Spacer	1	
7	3300306	Nut	1	
8	2220887	Plug	1	
9	4640709	Cartridge, Holding Valve	1	
	2900770	Seal Kit - 4640709 Valve	1	
10	3900171	Setscrew 1/2"-13NC x 1/2"	1	
11	2160002	Fitting, Grease	2	
12	Kit	Wiper, Rod	1	
13	Kit	Seal, Rod	1	
14	Kit	O-Ring	1	
15	Kit	Ring, Back-Up	1	
16	Kit	Ring, Wear	1	
17	Kit	Ring, Guide	2	
18	Kit	O-Ring	1	
19	Kit	Ring, Lock	1	
20	2220883	Plug	1	
	0100011	Loctite #242	A/R	
	0100038	Primer, Locking	A/R	
	0100035	Loctite #222	A/R	
	2901118	Seal Kit (Includes Items 12-19)	1	

SECTION 5 CYLINDER

FIGURE 5-9. LIFT CYLINDER ASSEMBLY - BOOM (GERMAN TUV STYLE)

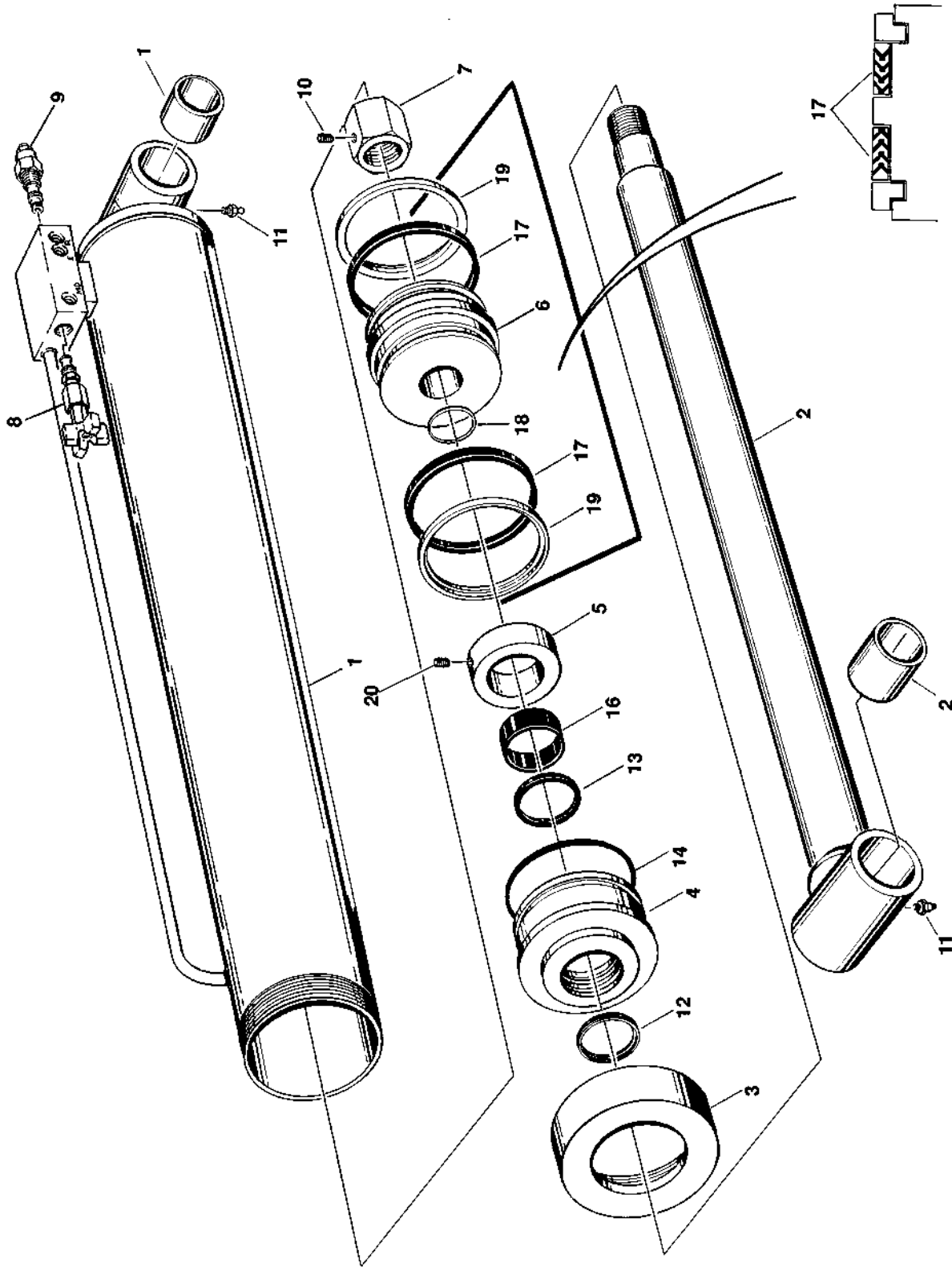

SECTION 5 CYLINDER

FIGURE 5-9. LIFT CYLINDER ASSEMBLY - BOOM (GERMAN TUV STYLE)

FIG & ITEM #	PART NUMBER	DESCRIPTION	QTY.	REV.
	1682587	LIFT CYLINDER ASSEMBLY - BOOM (GERMAN TUV STYLE)	Ref.	
1	1682588	Barrel Weldment	1	
	0961082	Bushing, Bronze	2	
2	1681835	Rod Weldment	1	
	0961082	Bushing, Bronze	2	
3	1120238	Retainer	1	
4	1681298	Head	1	
5	4565603	Spacer	1	
6	3480104	Piston	1	
7	3300297	Nut	1	
8	4640731	Valve, Needle	1	
9	4640495	Cartridge, Holding Valve	1	
	2900770	Seal Kit - 4640495 Valve	1	
10	3900171	Setscrew 1/2"-13NC x 1/2"	1	
11	2160002	Fitting, Grease	2	
12	Kit	Wiper, Rod	1	
13	Kit	Seal, Rod	1	
14	Kit	O-Ring	1	
15	Not Used			
16	Kit	Ring, Wear	1	
17	Kit	Ring, Guide	2	
18	Kit	O-Ring	1	
19	Kit	Ring, Lock	1	
20	3900141	Setscrew 1/4"-20NC x 3/8"	1	
	0100011	Loctite #242	A/R	
	0100038	Primer, Locking	A/R	
	0100035	Loctite #222	A/R	
	2900338	Seal Kit (Includes Items 12-19)	1	

SECTION 5 CYLINDER

FIGURE 5-10. LIFT CYLINDER ASSEMBLY - EXTEND-A-REACH (100HX+10 & 110HXER ONLY)

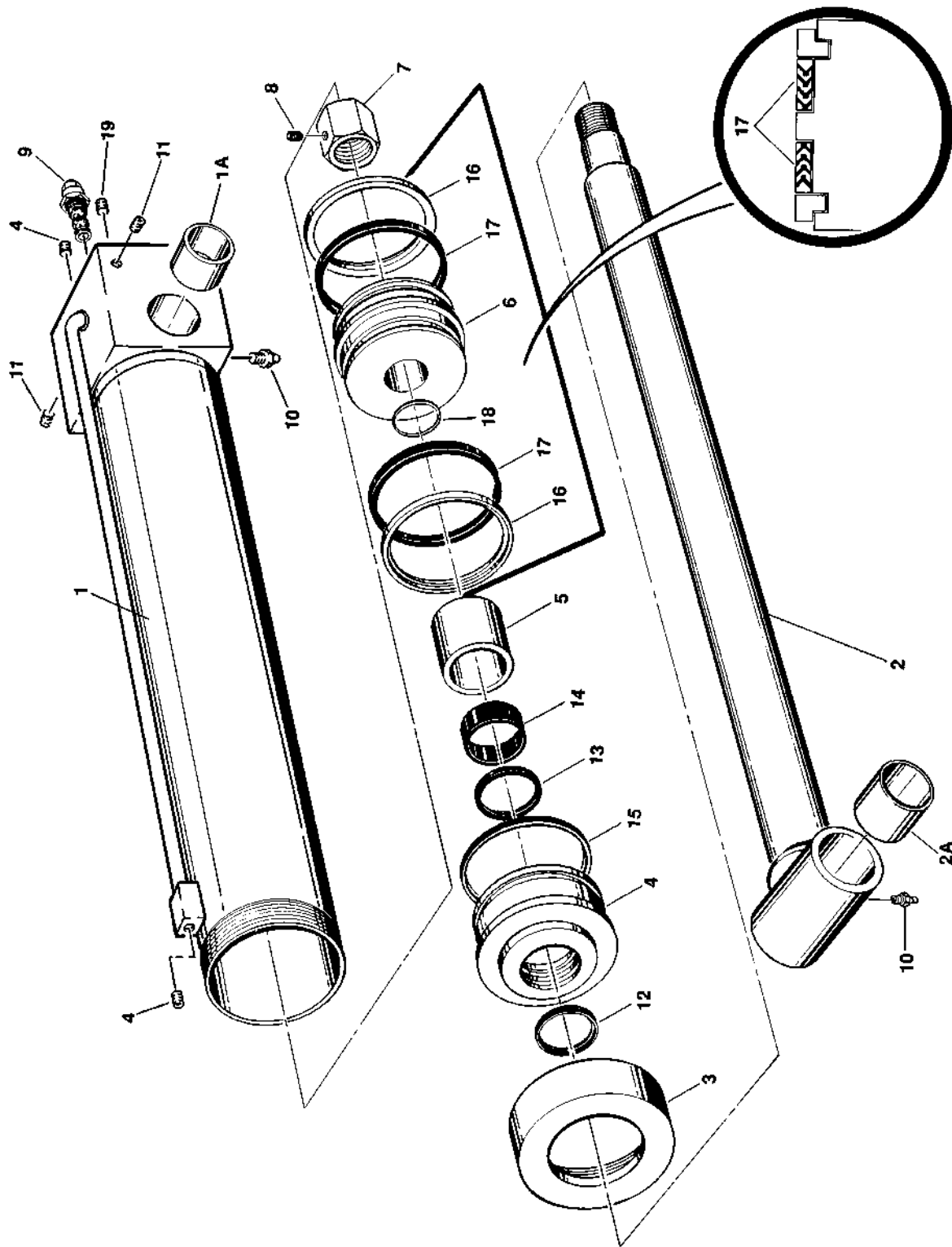

SECTION 5 CYLINDER

FIGURE 5-10. LIFT CYLINDER ASSEMBLY - EXTEND-A-REACH (100HX+10 & 110HXER ONLY)

FIG & ITEM #	PART NUMBER	DESCRIPTION	QTY.	REV.
		LIFT CYLINDER ASSEMBLY - EXTEND-A-REACH OPTIONS (STANDARD PARTS):	Ref.	
	1681955	Prior To May 1992	Ref.	C
	1682635	May 1992 To S/N 49403	Ref.	
	1683725	S/N 49403 To Present	Ref.	1
1		Barrel Weldment Options:	1	
	1681956	Prior to May 1992		
	1682636	May 1992 to S/N 49403		
	1683724	S/N 49403 to Present		
1A	0961185	Bushing, Bronze	2	
2		Rod Weldment Options:	1	
	1681957	Prior to May 1992		
	1682638	May 1992 to Present		
2A		Bushing, Bronze Options:	A/R	
	Not Required	Prior to May 1992	0	
	0961595	May 1992 to Present	2	
3	1120305	Retainer	1	
4	1681423	Head	1	
5	4564009	Spacer	1	
6	3480113	Piston	1	
7		Nut Options:	1	
	3300226	Nut (Prior to May 1991)	1	
	3300285	Nut, Hex (May 1991 to Present)	1	
8		Setscrew Options:	A/R	
	3900141	Setscrew 1/4"-20NC x 3/8"	2	
	3900170	Setscrew 3/8"-16NC x 3/8"	1	
9	4640495	Cartridge, Holding Valve	1	
	2900770	Seal Kit - 4640495 Valve	1	
10	2160002	Fitting, Grease	2	
11	2200201	Plug, Pipe 1/8" NPT	4	
12	Kit	Wiper, Rod	1	
13	Kit	Seal, Rod	1	
14	Kit	Ring, Wear	1	
15	Kit	Seal, Head	1	
16	Kit	Ring, Guide	2	
17	Kit	Ring, Lock	2	
18	Kit	O-Ring	1	
19	2200222	Plug, Pipe 1/4" NPT	2	

	0100020	Sealant, Pipe	A/R	
	0100011	Loctite #242	A/R	
	0100038	Primer, Locking	A/R	
	0100035	Loctite #222	A/R	

	2901142	Seal Kit (Includes Items 12-18)	1	

SECTION 5 CYLINDER

FIGURE 5-11. MASTER CYLINDER ASSEMBLY

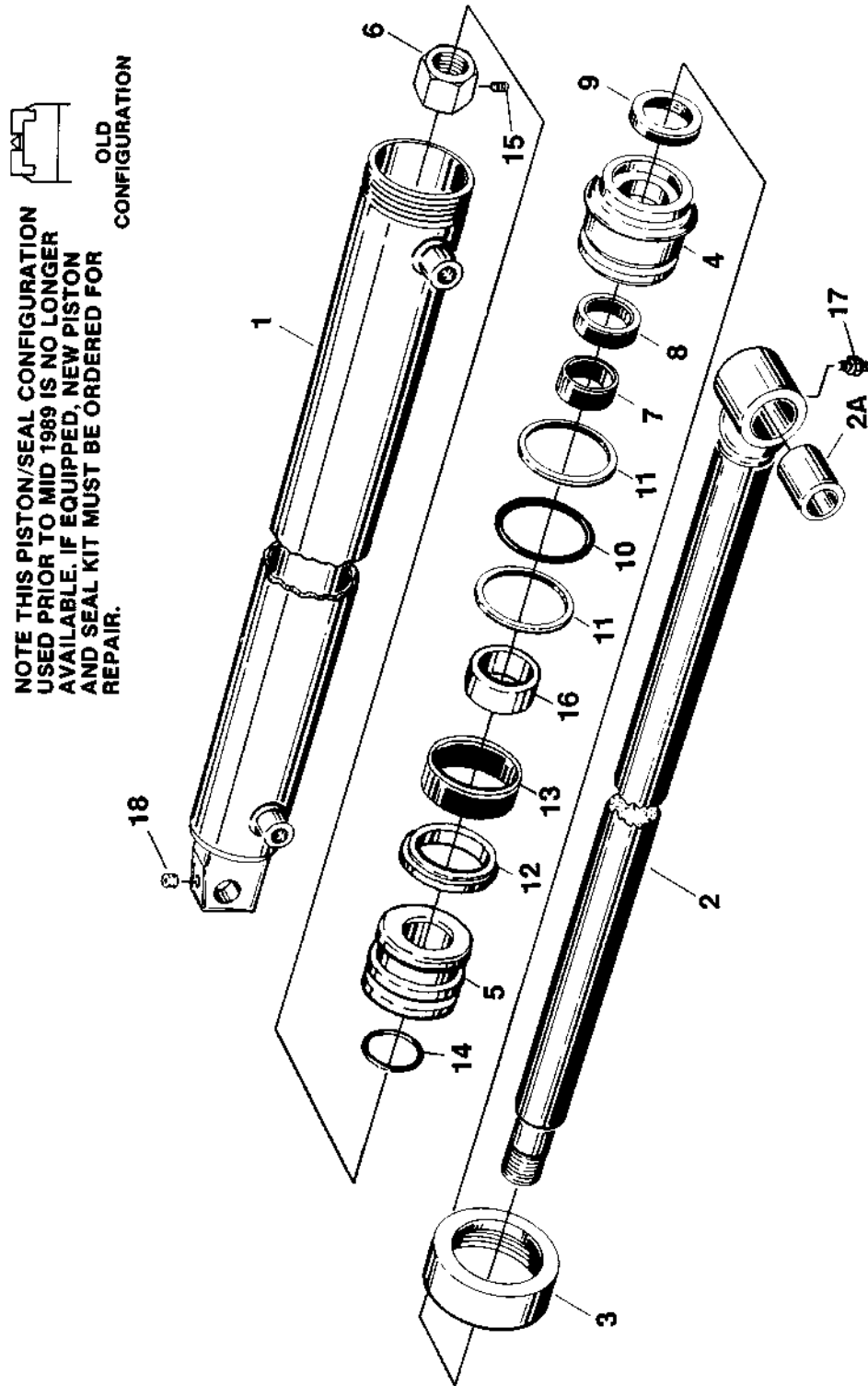

SECTION 5 CYLINDER

FIGURE 5-11. MASTER CYLINDER ASSEMBLY

FIG & ITEM #	PART NUMBER	DESCRIPTION	QTY.	REV.
		MASTER CYLINDER ASSEMBLY		
		Note: Refer to P/N stamped on Barrel for identification. Also, all 1681978 Cylinders have the new piston configuration.		
	1681978	100HX & 110HX	Ref.	C
	1681978	100HX+10 & 110HXER With 4620038 Turntable	Ref.	C
	1681580	100HX+10 & 110HXER With 4620044 & 4620078 Turntables	Ref.	F
1	Not Used	Barrel Weldment Options:	1	
	1681979	100HX & 110HX		
	1681979	100HX+10 & 110HXER with 4620038 Turntable		
	1681490	100HX+10 & 110HXER with 4620044 & 4620078 Turntables	1	
2	Not Used	Rod Weldment Options:	1	
	1681974	100HX & 110HX		
	1681974	100HX+10 & 110HXER with 4620038 Turntable		
	1681488	100HX+10 & 110HXER with 4620044 & 4620078 Turntables		
2A	0960097	Bushing, Bronze	1	
3	1120179	Retainer	1	
4	1680892	Head	1	
5	3480120	Piston	1	
6		Nut Options:	1	
	3300101	Nut (Prior to August 1992)		
	3300272	Nut, Hex (August 1992 to Present)		
7	Kit	Ring, Wear	1	
8	Kit	Z-Seal	1	
9	Kit	Wiper, Rod	1	
10	Kit	O-Ring	1	
11	Kit	Ring, Back-Up	2	
12	Kit	Seal, Piston	1	
13	Kit	Ring, Wear	1	
14	Kit	O-Ring	1	
15	3900170	Setscrew 3/8"-16NC x 3/8"	1	
16	Not Used	Tube, Spacer Options:	1	
	4564057	100HX & 110HX		
	4564057	100HX+10 & 110HXER with 4620038 Turntable		
	4563031	100HX+10 & 110HXER with 4620044 & 4620078 Turntables		
17	2160002	Fitting, Grease	1	
18	2200201	Plug, Pipe 1/8" NPT	1	
	0100011	Loctite #242	A/R	
	0100038	Primer, Locking	A/R	
	0100035	Loctite #222	A/R	
	2900381	Seal Kit (Includes Items 7-14)	1	

SECTION 5 CYLINDER

FIGURE 5-12. STEER CYLINDER ASSEMBLY

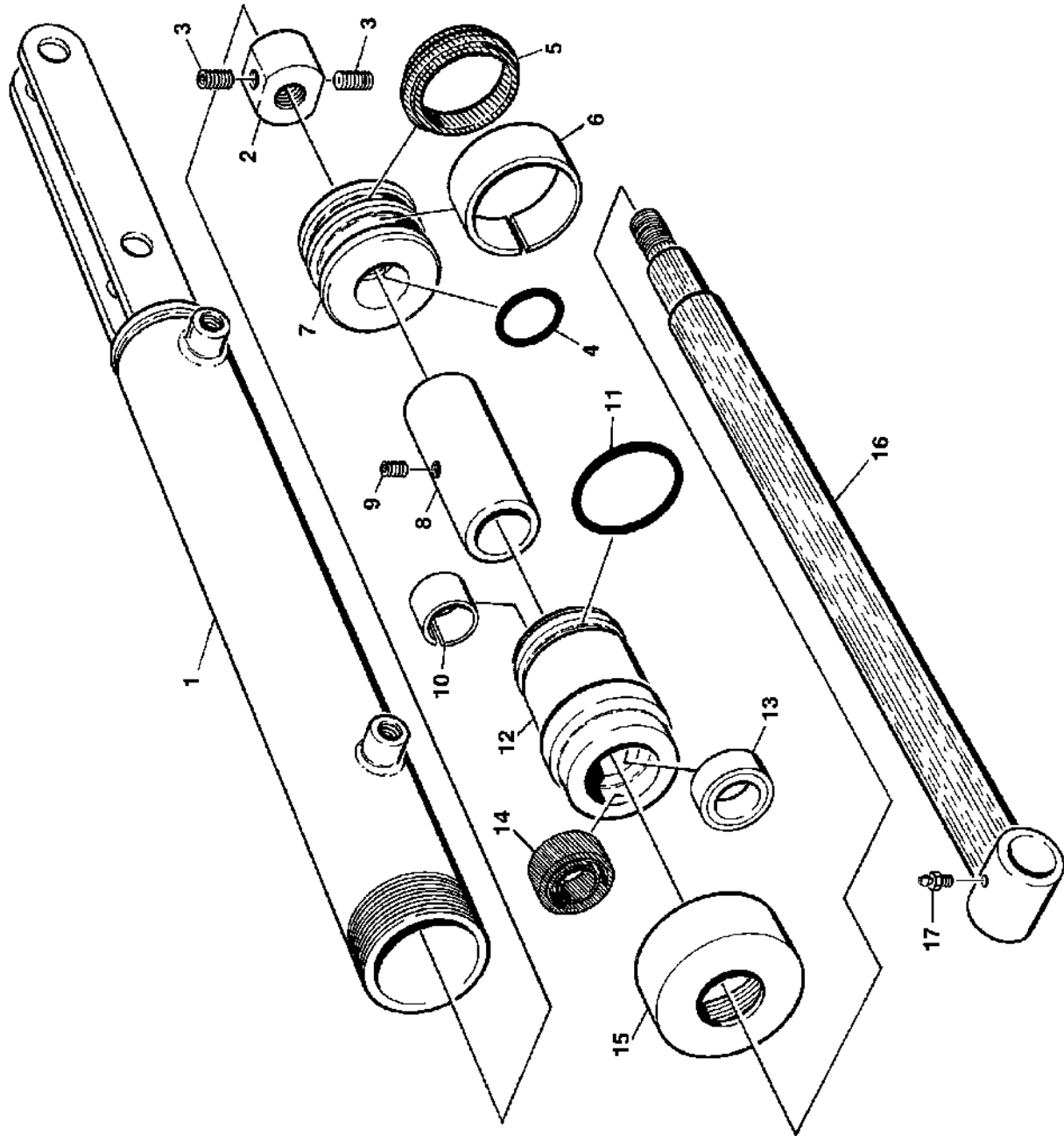

SECTION 5 CYLINDER

FIGURE 5-12. STEER CYLINDER ASSEMBLY

FIG & ITEM #	PART NUMBER	DESCRIPTION	QTY.	REV.
	1681934	STEER CYLINDER ASSEMBLY	Ref.	E
1	1681933	Barrel	1	
2		Nut Options:	1	
	3300187	Nut (Prior to August 1992)		
	3300273	Nut, Hex (August 1992 to Present)		
3		Setscrew Options:	A/R	
	3900141	Setscrew 1/4"-20NC x 3/8" (Prior to August 1992)	2	
	3900170	Setscrew 3/8"-16NC x 3/8" (August 1992 to Present)	1	
4	Kit	O-Ring	1	
5	Kit	T-Seal	1	
6	Kit	Ring, Wear	1	
7	3480134	Piston	1	
8	4563963	Spacer	1	
9	3900141	Setscrew 1/4"-20NC x 3/8"	1	
10	Kit	Ring, Wear	1	
11	Kit	O-Ring	1	
12	1681344	Head	1	
13	Kit	Seal, Rod	1	
14	Kit	Wiper, Rod	1	
15	1120108	Retainer	1	
16	1681411	Rod	1	
17	2160002	Fitting, Grease	1	

	0100011	Loctite #242	A/R	
	0100038	Loctite, Primer	A/R	
	0100035	Loctite #222	A/R	

	2901123	Seal Kit (Includes Items 4, 5,6, 10, 11, 13 and 14)	1	

SECTION 5 CYLINDER

FIGURE 5-13. TELESCOPE CYLINDER ASSEMBLIES

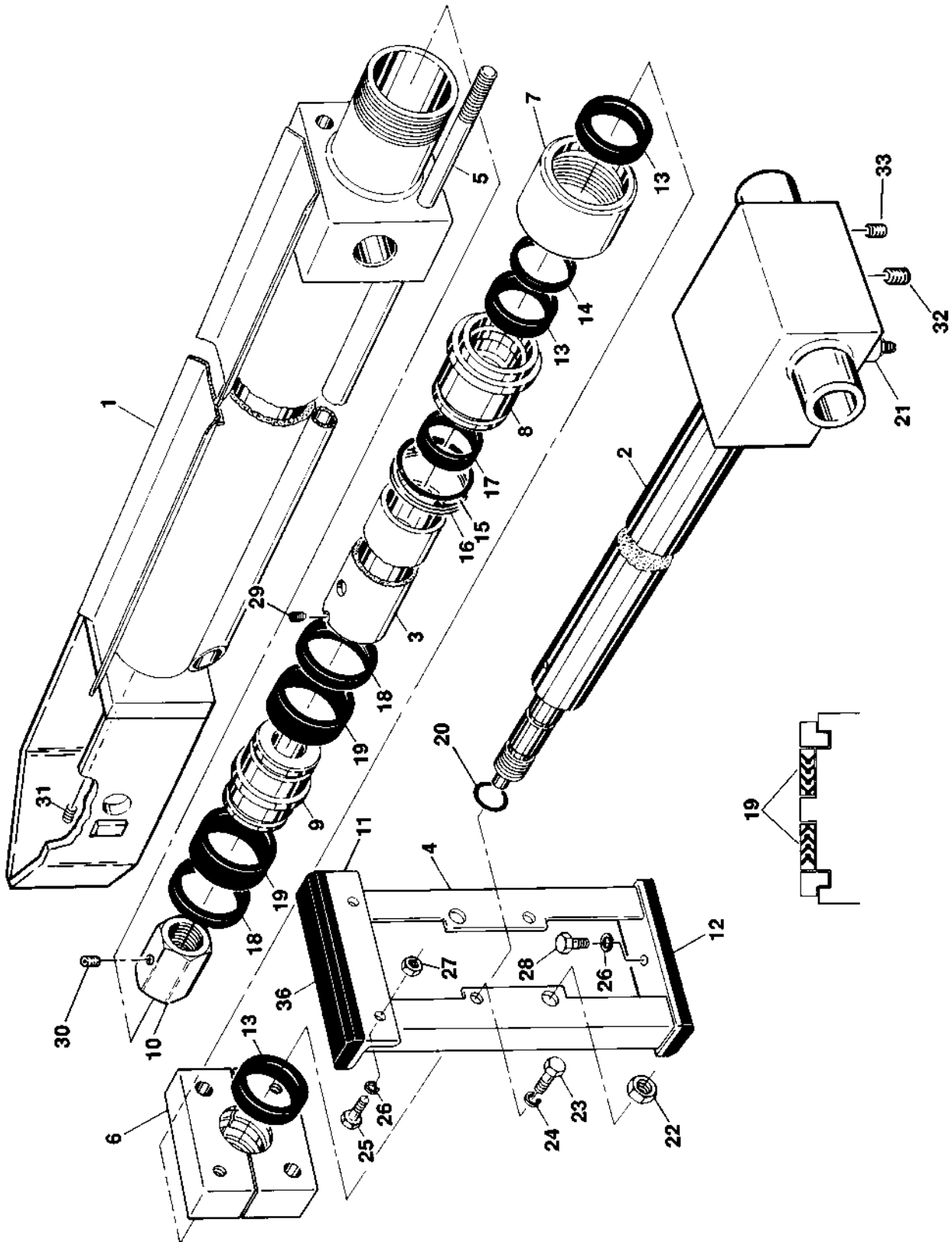

SECTION 5 CYLINDER

FIGURE 5-13. TELESCOPE CYLINDER ASSEMBLIES

FIG & ITEM #	PART NUMBER	DESCRIPTION	QTY.	REV.
		TELESCOPE CYLINDER ASSEMBLIES	Ref.	
	1682032	100HX, 100HX+10 & 110HXER Prior To October 1992	Ref.	E
	1682821	100HX, 100HX+10 & 110HXER October 1992 To Present	Ref.	A
	1682030	110HX Prior To October 1992	Ref.	D
	1682820	110HX October 1992 To Present	Ref.	A
1		Barrel Weldment Options:	1	
	1681949	Prior to October 1992		
	1681926	October 1992 to Present		
2		Rod Weldment Options:	1	
	1681950	Prior to October 1992		
	1681922	October 1992 to Present		
3	1682031	Spacer	1	
4	4843016	Rod Support Weldment	1	
5	3840944	Rod, Guide	2	
6	0560773	Block, Nylatron	1	
7	1120345	Retainer	1	
8		Head Options:	1	
	1681925	Prior to October 1992		
	1682298	October 1992 to Present		
9	3480133	Piston	1	
10		Nut Options:	1	
	3300249	Nut (Prior to January 1991)		
	3300299	Nut, Hex (January 1991 to Present)		
11	0181404	Angle	1	
12	3340560	Pad, Wear	1	
13	Kit	Seal, Rod	3	
14	Kit	Wiper, Rod	1	
15	Kit	O-Ring	1	
16	Kit	Ring, Back-Up	1	
17	Kit	Ring, Wear	1	
18	Kit	Ring, Guide	2	
19	Kit	Seal, Piston	2	
20	Kit	T-Seal	1	
21	4640487	Cartridge, Valve	1	
	7011317	Kit, Seal	1	
22	3312202	Nut, Jam 3/4"-10NC	2	
23	0641812	Bolt 1/2"-13NC x 1 1/2"	2	
24	4761800	Lockwasher 1/2"	2	
25	0641608	Bolt 3/8"-16NC x 1"	2	
26	4761600	Lockwasher 3/8"	7	
27	3311601	Nut 3/8"-16NC	2	
28	0641605	Bolt 3/8"-16NC x 5/8"	5	
29	3951405	Setscrew 1/4"-20NC x 5/8"	1	

SECTION 5 CYLINDER

SECTION 5 CYLINDERS

FIGURE 5-13. TELESCOPE CYLINDER ASSEMBLIES (CONTINUED)

FIG & ITEM #	PART NUMBER	DESCRIPTION	QTY.	REV.
30		Setscrew Options:	A/R	
	3951403	Setscrew 1/4"-20NC x 3/8" (Prior to January 1991)	2	
	3900171	Setscrew 1/2"-13NC x 1/2" (January 1991 to Present)	1	
31	2200221	Plug, Pipe 1/8" NPT	1	
32	2200224	Plug, Pipe 3/8" NPT	2	
33	2200222	Plug, Pipe 1/4" NPT	1	
34	Not Used			
35	Not Used			
36	3340566	Pad, Wear	1	

	0100020	Sealant, Pipe	A/R	
	0100011	Loctite #242	A/R	
	0100035	Loctite #222	A/R	
	0100038	Primer, Locking	A/R	

	2901109	Seal Kit (Includes Items 13-20) (Prior to October 1992)	1	
	2901234	Seal Kit (Includes Items 13-20) (October 1992 to Present)	1	

SECTION 5 CYLINDER

FIGURE 5-13. TELESCOPE CYLINDER ASSEMBLIES (CONTINUED)

FIG & ITEM #	PART NUMBER	DESCRIPTION	QTY.	REV.

SECTION 5 CYLINDER

FIGURE 5-14. CYLINDER BELLOWS INSTALLATION

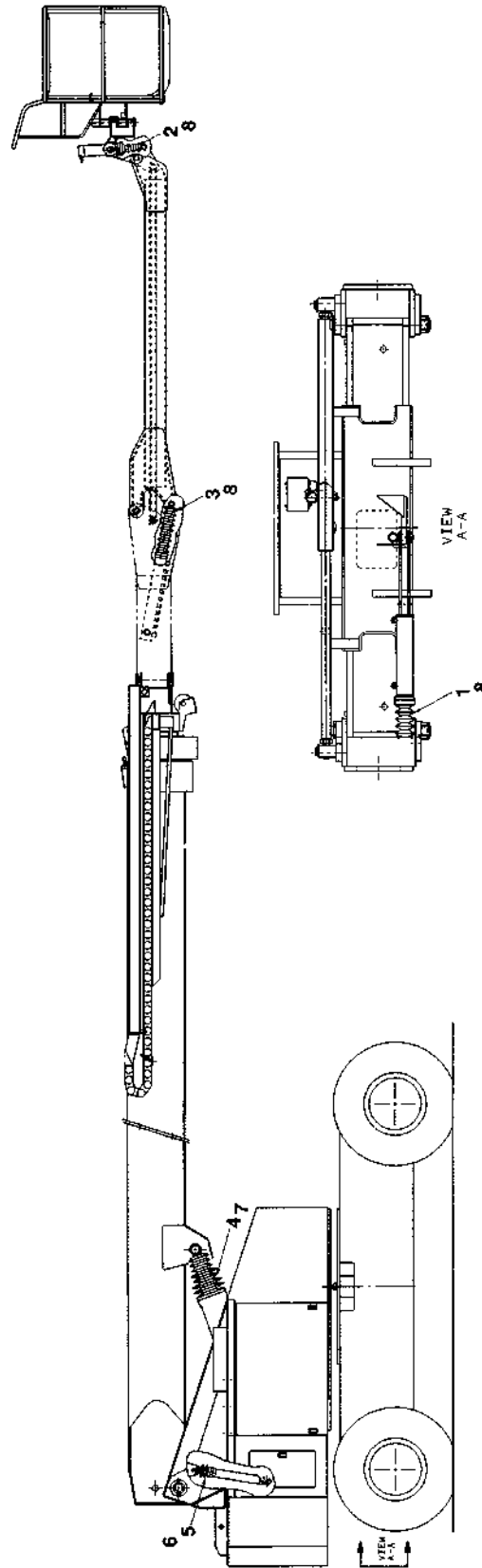

SECTION 5 CYLINDER

FIGURE 5-14. CYLINDER BELLOWS INSTALLATION

FIG & ITEM #	PART NUMBER	DESCRIPTION	QTY.	REV.
		CYLINDER BELLOWS INSTALLATION (OPTIONAL)	Ref.	
	0239258	100HX & 110HX Prior To May 1992	Ref.	B
	0253636	100HX & 110HX May 1992 To Present	Ref.	2
	0253637	100HX+10 & 110HXER May 1992 To Present	Ref.	2
1	0460075	Bellow (Steer)	1	
2		Bellow (Platform Level) Options:	1	
	0460080	100HX & 110HX Prior To May 1992		
	0460071	100HX & 110HX May 1992 To Present		
	0460088	100HX+10 & 110HXER May 1992 To Present		
3		Bellow (Extend-A-Reach Lift)	A/R	
	Not Required	100HX & 110HX Prior To May 1992	0	
	Not Required	100HX & 110HX May 1992 To Present	0	
	0460087	100HX+10 & 110HXER May 1992 To Present	1	
4		Bellow (Boom Lift) Options:	1	
	0460079	100HX & 110HX Prior To May 1992		
	0460086	100HX & 110HX May 1992 To Present		
	0460086	100HX+10 & 110HXER May 1992 To Present		
5	0460071	Bellow (Master) Options:	1	
6	1320037	Clamp	1	
7	1320059	Clamp	1	
8	1320122	Clamp	2	

SECTION 5 CYLINDER

**S
E
C
T
I
O
N

5

C
Y
L
I
N
D
E
R
S**

FIGURE 5-14. CYLINDER BELLOWS INSTALLATION (CONTINUED)

FIG & ITEM #	PART NUMBER	DESCRIPTION	QTY.	REV.

SECTION 6 HYDRAULICS

TABLE OF CONTENTS		
FIGURE	DESCRIPTION	PAGE
6-1	HYDRAULIC DIAGRAM LIST	6-2
6-2	HYDRAULIC DIAGRAM - AXLE EXTENSION AND STEER (WITHOUT TWO PACKAGE AND WITH DUAL FRAME JACKS).....	6-4
6-3	HYDRAULIC DIAGRAM - BRAKE WITH PRESSURE REDUCING VALVE (USED WITH AUSCO DRIVE BRAKE).....	6-6
6-4	HYDRAULIC DIAGRAM - DRIVE	6-8
6-5	HYDRAULIC DIAGRAM - EXTEND-A-REACH (100HX+10 AND 110HXER).....	6-12
6-6	HYDRAULIC DIAGRAM - LEVEL	6-14
6-7	HYDRAULIC DIAGRAM - LIFT	6-16
6-8	HYDRAULIC DIAGRAM - PUMP	6-18
6-9	HYDRAULIC DIAGRAM - ROTATE	6-22
6-10	HYDRAULIC DIAGRAM - SEQUENCE LINE	6-24
6-11	HYDRAULIC DIAGRAM - SWING	6-26
6-12	HYDRAULIC DIAGRAM - TELESCOPE.....	6-28

SECTION 6 HYDRAULICS

FIGURE 6-1. HYDRAULIC DIAGRAM LIST

FIG & ITEM #	PART NUMBER	DESCRIPTION
		HYDRAULIC DIAGRAM LIST Note: Diagrams with asterisk (*) are shown in the following pages. Information on diagrams not shown are available from the JLG Service/Parts Department.
	2791454	Axle Jack Hydraulic Diagram (Single Axle Jack without Tow Package) (For other options see Axle Extension Hydraulic Diagrams)
	2791431	Axle Extension/Steering/Axle Jack/Tow Hydraulic Diagrams: Without Tow Package & Without Axle Jacks
	2792283*	Without Tow Package & With Dual Axle Jacks
	2791926	With Tow Package & Without Axle Jacks
	2791552*	Brake with Pressure Reducing Valve (Used with Ausco Drive Brakes)
	2791423*	Drive Hydraulic Diagram
	2791425*	Extend-A-Reach Hydraulic Diagram (100HX+10 & 110HXER Only)
		Level Hydraulic Diagrams:
		100HX & 110HX:
	2791428	Prior to June 1993
	2792026*	June 1993 to present
		100HX+10 & 110HXER:
	2791605	Prior to November 1992
	2791993	November 1992 to June 1993
	2792025*	June 1993 to Present
		Lift Hydraulic Diagrams:
	2791599	4620044 Turntable
	2791599	4620078 Turntable Machines Built Prior to September 1995
	2792235*	4620078 Turntable Machines Built September 1995 to Present
	1692883	Manual Descent Hydraulic Diagram (Prior to October 1992)
	0253729	Manual Descent Hydraulic Diagram (October 1992 to Present)
	0252917	Oil Cooler Hydraulic Diagram
		Pump Hydraulic Diagrams:
	2791438*	Deutz Engine Machines
	2791594*	Ford & Cummins Engine Machines
		Rotate Hydraulic Diagrams:
	2791604*	100HX & 110HX
	2791433	100HX+10 & 110HXER (Prior to May 1992)
	2791987*	100HX+10 & 110HXER (May 1992 to Present)
	0251703/1281353*	Sequence Hydraulic Diagram

SECTION 6 HYDRAULICS

FIGURE 6-1. HYDRAULIC DIAGRAM LIST (Continued)

FIG & ITEM #	PART NUMBER	DESCRIPTION
		Steer Hydraulic Diagrams (See Axle Extension Hydraulic Diagrams)
	2791426*	Swing Hydraulic Diagram
	2791427*	Telescope Hydraulic Diagram
		Tow Hydraulic Diagram (See Axle Extension Hydraulic Diagrams)

SECTION 6 HYDRAULICS

FIGURE 6-2. HYDRAULIC DIAGRAM - AXLE EXTENSION & STEER (WITHOUT TOW PACKAGE & WITH DUAL FRAME JACKS)

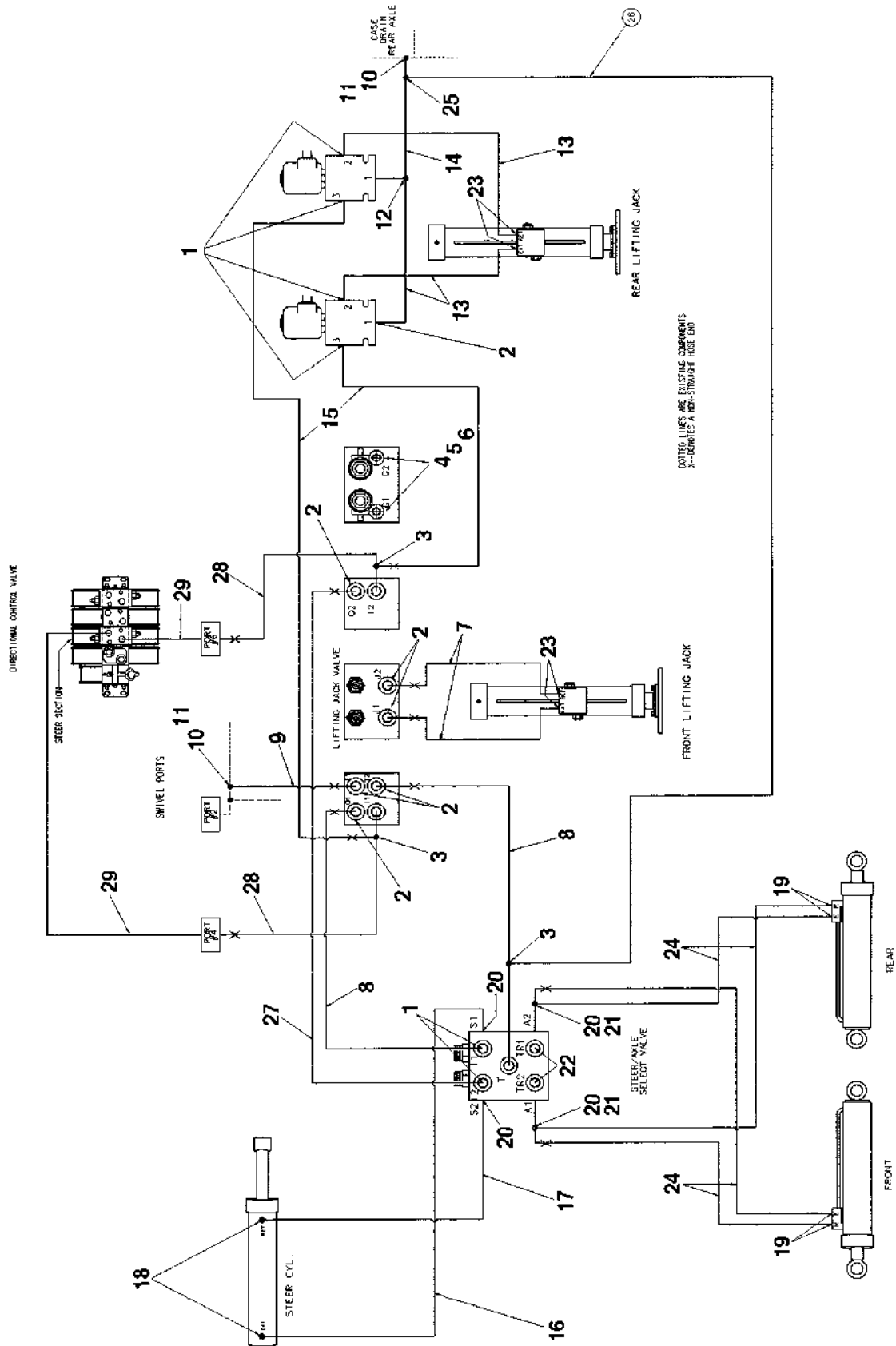

SECTION 6 HYDRAULICS

FIGURE 6-2. HYDRAULIC DIAGRAM - AXLE EXTENSION & STEER (WITHOUT TOW PACKAGE & WITH DUAL FRAME JACKS)

FIG & ITEM #	PART NUMBER	DESCRIPTION	QTY.	REV.
	2792283	HYDRAULIC DIAGRAM - AXLE EXTENSION AND STEER (WITHOUT TOW PACKAGE & WITH DUAL FRAME JACKS)	Ref.	2/B
1	2220473	Fitting, 90°	6	
2	2220371	Fitting, Straight	6	
3	2220606	Fitting, Tee	3	
4	2220873	Fitting, Straight	2	
5	2220428	Fitting, Quick Disconnect	2	
6	2220429	Fitting, Dust Cap	2	
7	2752461	Hose	2	
8	2751003	Hose	2	
9	2752462	Hose	1	
10	2220385	Fitting, Tee	2	
11	2220619	Fitting, Reducer	2	
12	2220899	Fitting, Tee	1	
13	2752470	Hose	3	
14	2752471	Hose	1	
15	2751114	Hose	2	
16	2750896	Hose	1	
17	2750891	Hose	2	
18	2220414	Fitting, Straight	2	
19	2220416	Fitting, 90°	4	
20	2220582	Fitting, Straight	4	
21	2220605	Fitting, Tee	2	
22	2220237	Fitting, Plug	2	
23	2220399	Fitting, Straight	4	
24	2751395	Hose	2	
25	2220635	Fitting, Tee	1	
26	2751132	Hose	1	
27	2750779	Hose	1	
28	2750991	Hose	2	
29	2750908	Hose	2	

SECTION 6 HYDRAULICS

FIGURE 6-3. HYDRAULIC DIAGRAM - BRAKE WITH PRESSURE REDUCING VALVE (USED WITH AUSCO DRIVE BRAKES)

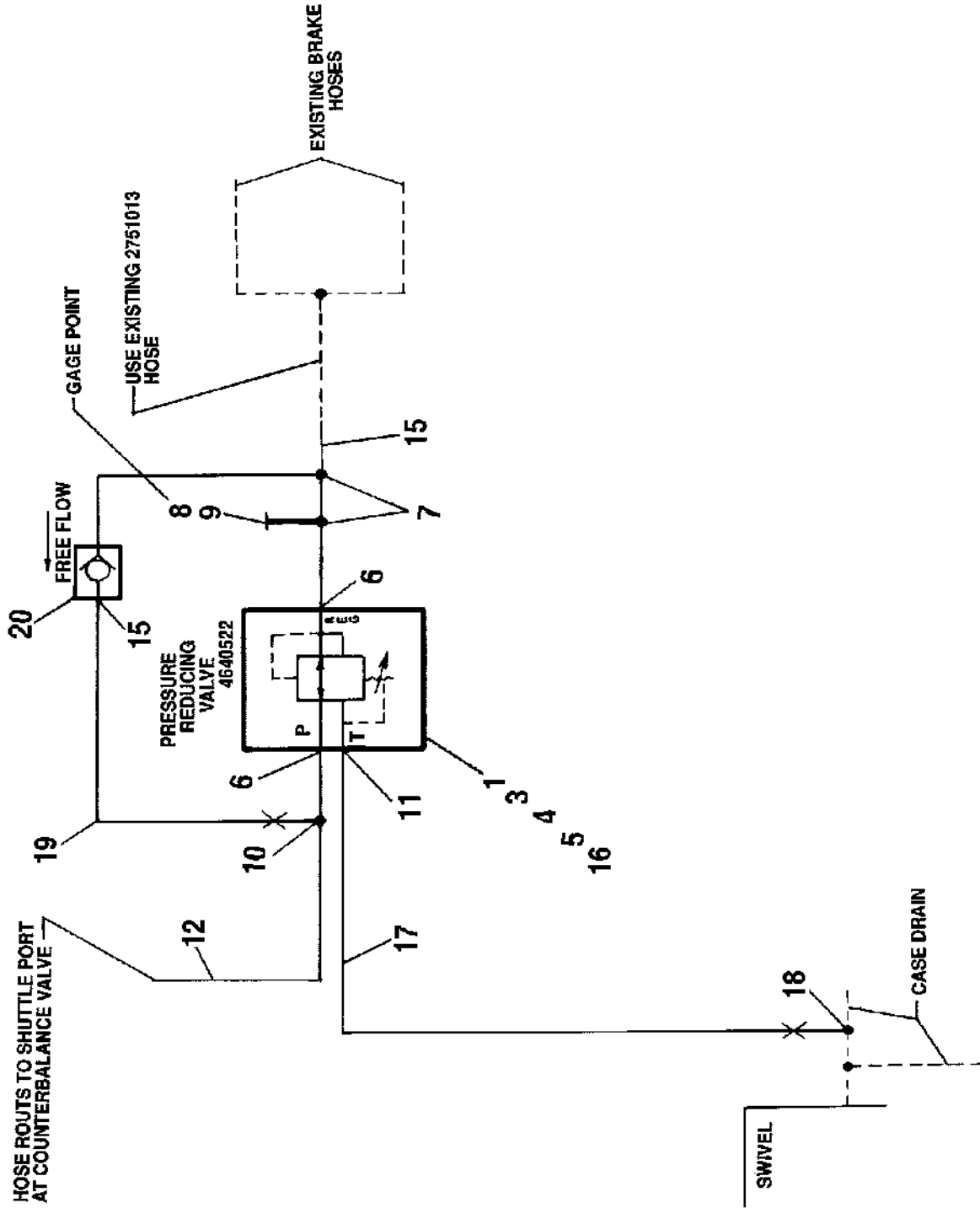

SECTION 6 HYDRAULICS

FIGURE 6-3. HYDRAULIC DIAGRAM - BRAKE WITH PRESSURE REDUCING VALVE (USED WITH AUSCO DRIVE BRAKES)

FIG & ITEM #	PART NUMBER	DESCRIPTION	QTY.	REV.
	2791552	HYDRAULIC DIAGRAM - BRAKE WITH PRESSURE REDUCING VALVE (USED WITH AUSCO DRIVE BRAKES)	Ref.	D
1	4640522	Valve, Pressure Reducing	1	
2	Not Used			
3	3311401	Nut 1/4"-20NC	2	
4	4761400	Lockwasher 1/4"	2	
5	4751400	Flatwasher 1/4"	4	
6	2220250	Fitting, Reducer	2	
7	2220752	Fitting, Tee	2	
8	2220428	Fitting, Quick Disconnect	1	
9	2220429	Cap, Dust	1	
10	2220584	Fitting, Pipe	1	
11	2220417	Fitting, Straight	1	
12	2751397	Hose	1	
13	Not Used			
14	Not Used			
15	2220414	Fitting, Straight	2	
16	0641416	Bolt 1/4"-20NC x 2"	2	
17	2750899	Hose	1	
18	2220605	Fitting, Tee	1	
19	2751018	Hose	1	
20	4640197	Valve, Check	1	

SECTION 6 HYDRAULICS

FIGURE 6-4. HYDRAULIC DIAGRAM - DRIVE

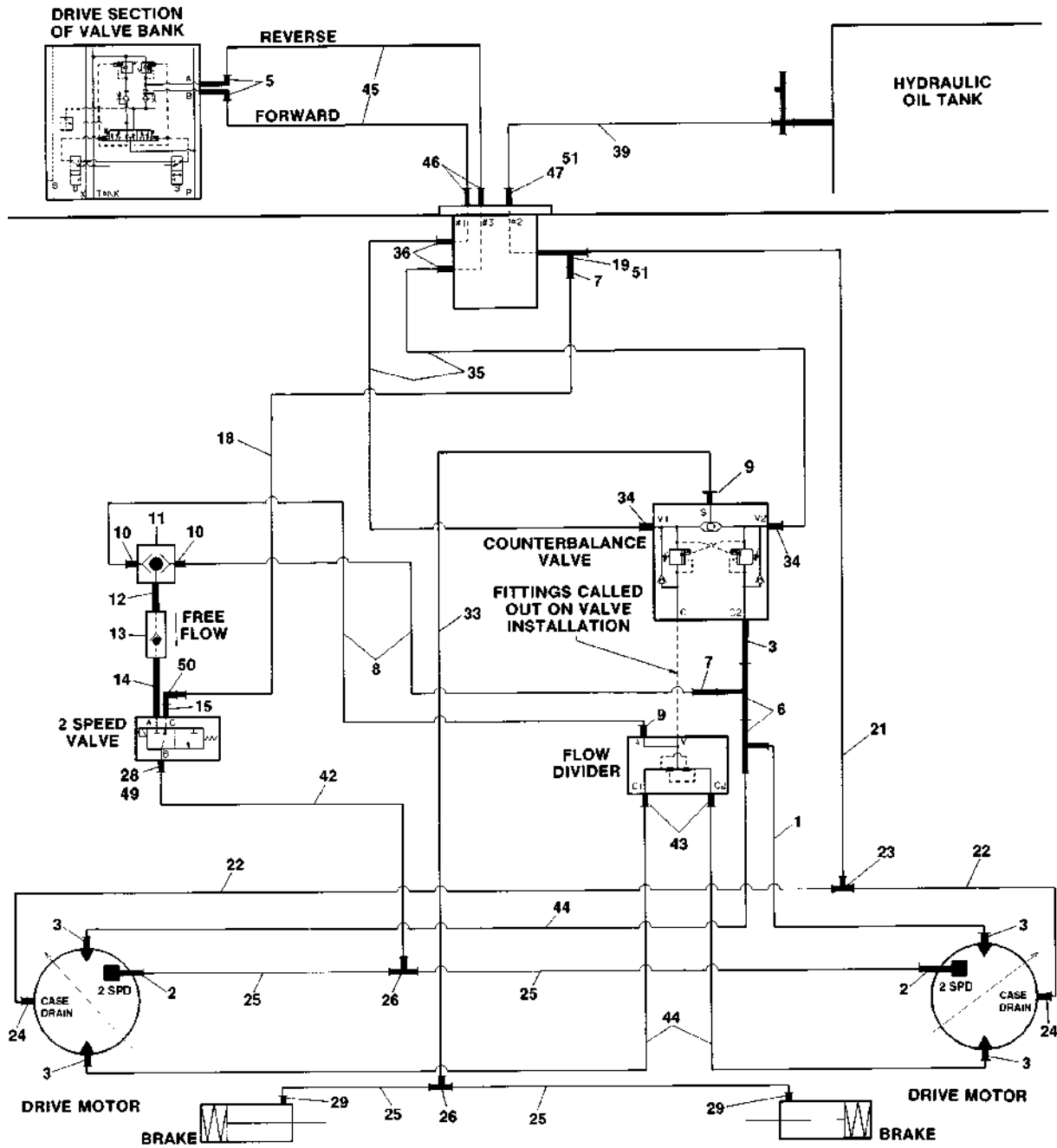

SECTION 6 HYDRAULICS

FIGURE 6-4. HYDRAULIC DIAGRAM - DRIVE

FIG & ITEM #	PART NUMBER	DESCRIPTION	QTY.	REV.
	2791423	HYDRAULIC DIAGRAM - DRIVE	Ref.	6
1	2751466	Hose	1	
2	2220415	Fitting, Straight	2	
3	2220800	Fitting, Straight	5	
4	Not Used			
5	2220451	Fitting, Straight	2	
6	2220385	Fitting, Tee	2	
7	2220618	Fitting, Reducer	2	
8	2750889	Hose	2	
9	2220466	Fitting, 90°	2	
10	2220414	Fitting, Straight	2	
11	4640013	Valve, Shuttle	1	
12	2220261	Fitting, Straight	1	
13	4640197	Valve, Check	1	
14	2220673	Fitting, 90°	1	
15	2220417	Fitting, Straight	1	
16	Not Used			
17	Not Used			
18	2751010	Hose	1	
19	2220602	Fitting, Tee	1	
20	0100020	Sealant, Pipe	A/R	
21	2750979	Hose	1	
22	2750759	Hose	2	
23	2220362	Fitting, Tee	1	
24	2220374	Fitting, Straight	2	
25	2750894	Hose	4	
26	2220504	Fitting, Tee	2	
27	Not Used			
28	2220585	Fitting, 90°	1	
29	2220466	Fitting, 90°	2	
30	Not Used			
31	Not Used			
32	Not Used			
33	2751013	Hose	1	
34	2220465	Fitting, 90°	2	
35	2751339	Hose	2	
36	2220435	Fitting, Straight	2	
37	Not Used			
38	Not Used			
39	2750759	Hose	1	
40	Not Used			
41	Not Used			
42	2751409	Hose	1	
43	2220375	Fitting, Straight	2	
44	2751489	Hose	3	
45	2751337	Hose	2	
46	2220568	Fitting, 45°	2	
47	2220500	Fitting, 45°	1	

SECTION 6 HYDRAULICS

FIGURE 6-4. HYDRAULIC DIAGRAM - DRIVE (CONTINUED)

FIG & ITEM #	PART NUMBER	DESCRIPTION	QTY.	REV.
48	Not Used			
49	2220822	Fitting	1	
50	2220909	Fitting	1	
51	2220811	Fitting, Reducer	2	

SECTION 6 HYDRAULICS

FIGURE 6-4. HYDRAULIC DIAGRAM - DRIVE (CONTINUED)

FIG & ITEM #	PART NUMBER	DESCRIPTION	QTY.	REV.

SECTION 6 HYDRAULICS

FIGURE 6-5. HYDRAULIC DIAGRAM - EXTEND-A-REACH (100HX+10 AND 110HXER)

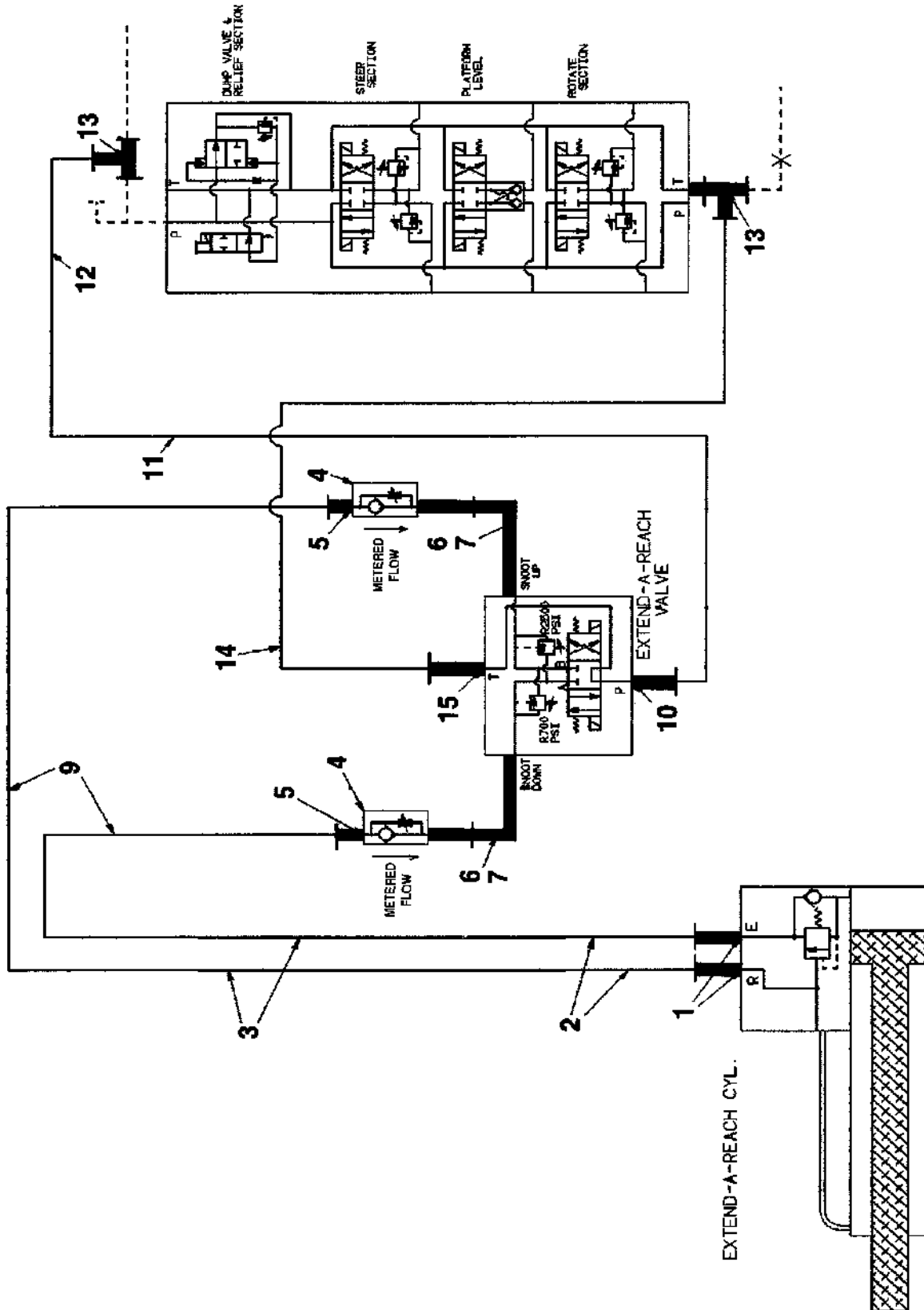

SECTION 6 HYDRAULICS

FIGURE 6-5. HYDRAULIC DIAGRAM - EXTEND-A-REACH (100HX+10 AND 110HXER)

FIG & ITEM #	PART NUMBER	DESCRIPTION	QTY.	REV.
	2791425	HYDRAULIC DIAGRAM - EXTEND-A-REACH (100HX+10 AND 110HXER)	Ref.	4
1	2220399	Fitting, Straight	2	
2	2751170	Hose	2	
3	4563167	Tube	2	
4	4640216	Valve, Color Flow (Adjustable Restrictor)	2	
5	2220343	Fitting, Straight	2	
6	2220280	Fitting, Straight	2	
7	2220113	Fitting, 90°	2	
8	0100020	Sealant, Pipe (Not Shown)	A/R	
9	2751168	Hose	2	
10	2220600	Fitting, Straight	1	
11	2750929	Hose	1	
12	2220386	Fitting, 90°	1	
13	2220385	Fitting, Tee	2	
14	2751494	Hose	1	
15	2220373	Fitting, Straight	1	

SECTION 6 HYDRAULICS

FIGURE 6-6. HYDRAULIC DIAGRAM - LEVEL

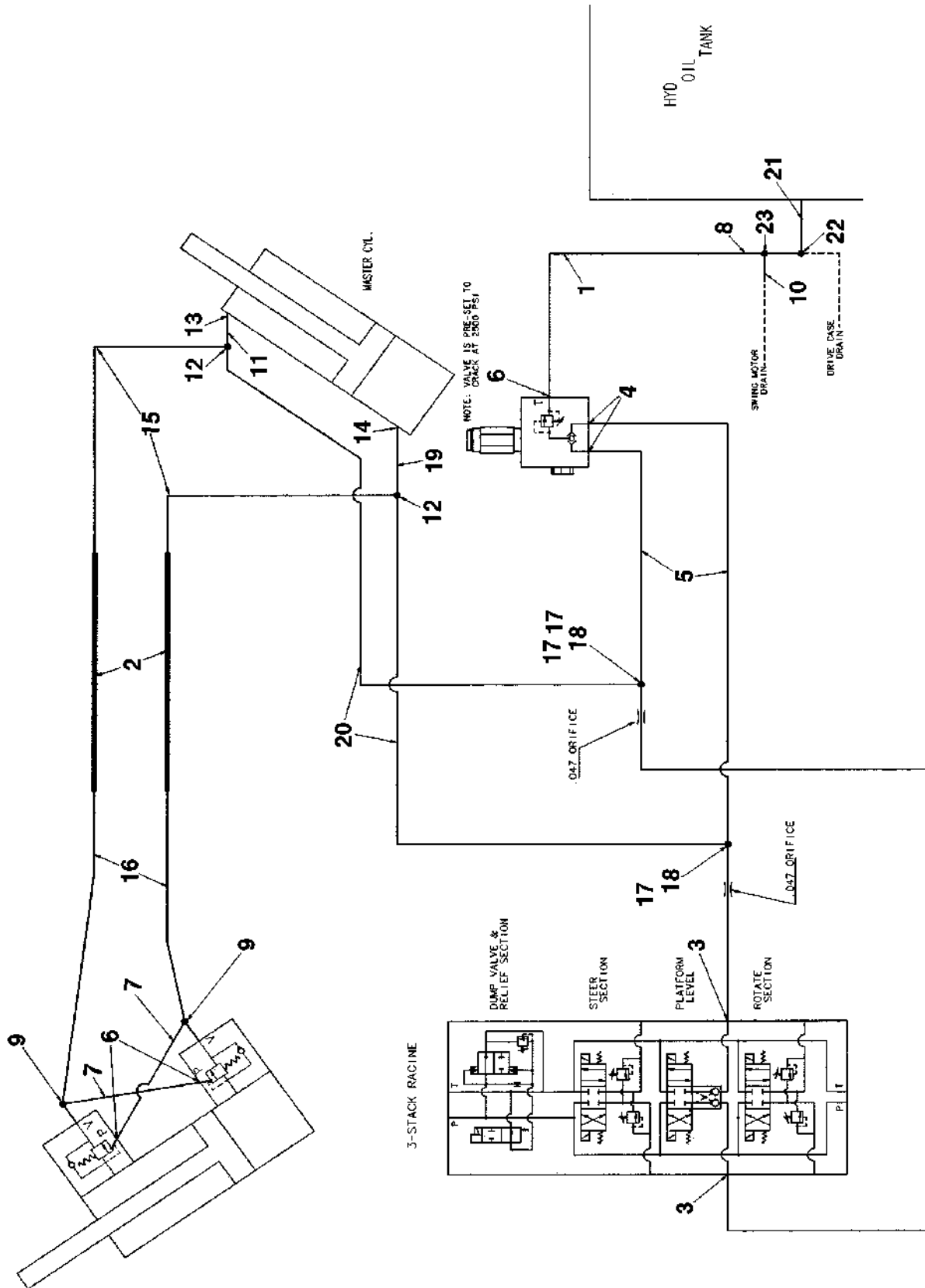

SECTION 6 HYDRAULICS

FIGURE 6-6. HYDRAULIC DIAGRAM - LEVEL

FIG & ITEM #	PART NUMBER	DESCRIPTION	QTY.	REV.
	2792026	HYDRAULIC DIAGRAM - LEVEL (100HX & 110HX)	Ref.	2
	2792025	HYDRAULIC DIAGRAM - LEVEL (100HX+10 & 110HXER)	Ref.	3
1	2750918	Hose	1	
2	4563167	Tube	2	
3	2220591	Fitting, Reducer	2	
4	2220371	Fitting, Straight	2	
5	2750778	Hose	2	
6	2220473	Fitting, 90°	3	
7	2750920	Hose (100HX & 110HX)	2	
	2751002	Hose (100HX+10 & 110HXER)	2	
8		Fitting, Straight Options:	1	
	2220607	Prior to S/N 36614		
	2220609	S/N 36614 to Present		
9	2220899	Fitting, Tee	2	
	2220606	Fitting, Tee	2	
10		Fitting, Straight Options:	1	
	2220417	Prior to S/N 36614		
	2220619	S/N 36614 to Present		
11	2750998	Hose	1	
12	2220490	Fitting, Tee	2	
13	2220343	Fitting, Straight	1	
14	2220495	Fitting, 90°	1	
15	2751830	Hose	2	
16	2751871	Hose (100HX & 110HX)	2	
	2752162	Hose (100HX+10 & 110HXER)	2	
17	2180615	Orifice (.047)	2	
18	2180379	Fitting, Modified Tee	2	
19	2750785	Hose	1	
20	2750991	Hose	2	
21	2220868	Fitting, Straight	1	
22		Fitting, Tee Options:	1	
	2220867	Prior to S/N 36614		
	2220362	S/N 36614 to Present		
23	2220444	Fitting, Tee	1	
	2220444	Prior to S/N 36614		
	2220635	S/N 36614 to Present		

SECTION 6 HYDRAULICS

FIGURE 6-7. HYDRAULIC DIAGRAM - LIFT

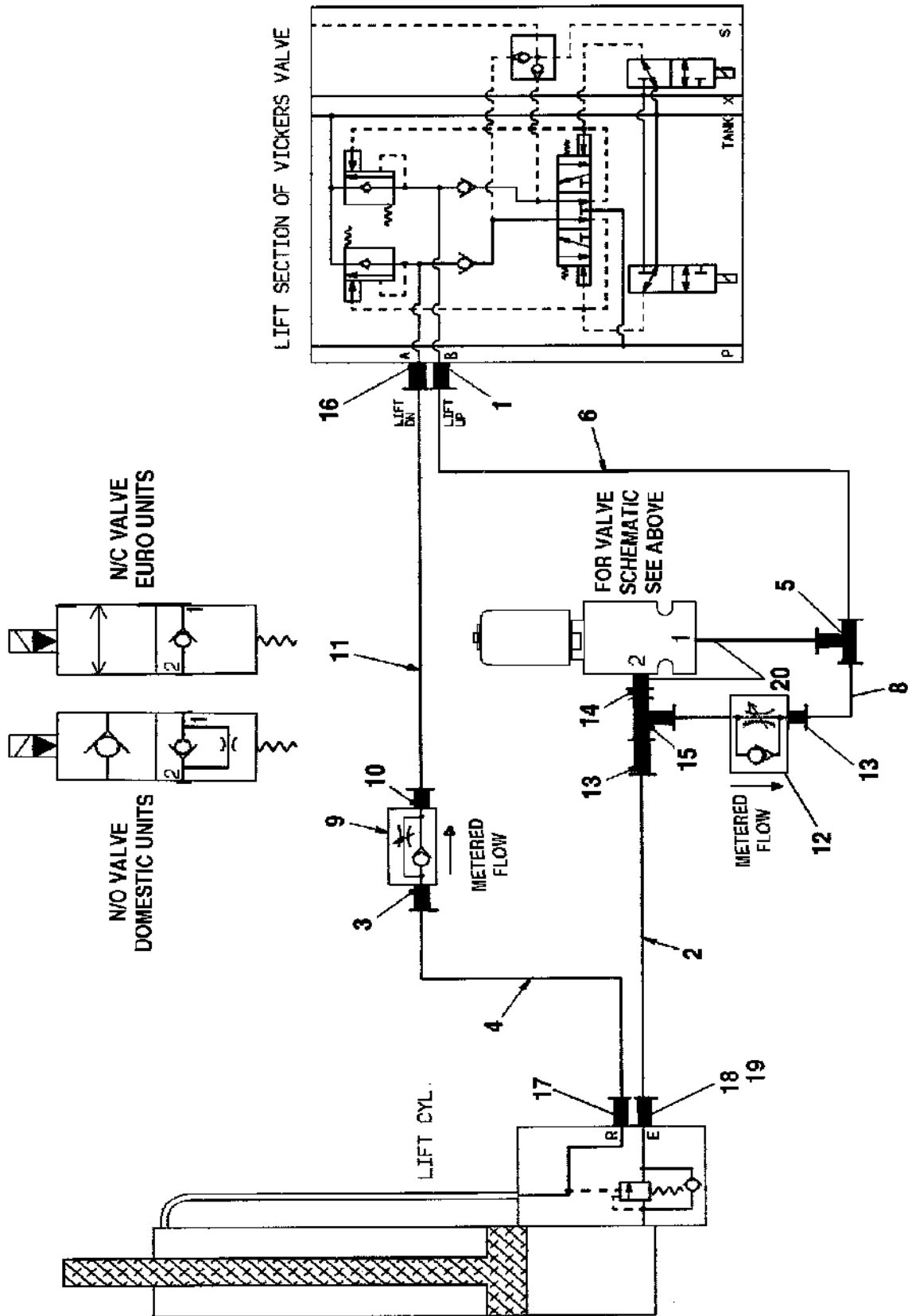

SECTION 6 HYDRAULICS

FIGURE 6-7. HYDRAULIC DIAGRAM - LIFT

FIG & ITEM #	PART NUMBER	DESCRIPTION	QTY.	REV.
	2792235	HYDRAULIC DIAGRAM - LIFT	Ref.	2
1	2220577	Fitting, Straight	1	
2	2751110	Hose	1	
3	2220343	Fitting, Straight	1	
4	2751111	Hose	1	
5	2220606	Fitting, Tee	1	
6	2750785	Hose	1	
7	0100020	Sealant, Pipe (Not Shown)	A/R	
8	2751002	Hose	1	
9	4640216	Valve, Color Flow 3/8"	1	
10	2220396	Fitting, Straight	1	
11	2220758	Fitting, Union	1	
12	4640128	Valve, Color Flow 1/4"	1	
13	2220773	Fitting, 90°	2	
14	2220727	Fitting, Reducer	1	
15	2220752	Fitting, Tee	1	
16	2220221	Fitting, Reducer	1	
17	2220473	Fitting, 90°	1	
18	2180480	Fitting, Straight	1	
19	2180682	Orifice (.109)	1	
20	2220591	Fitting	2	

SECTION 6 HYDRAULICS

FIGURE 6-8. HYDRAULIC DIAGRAM - PUMP

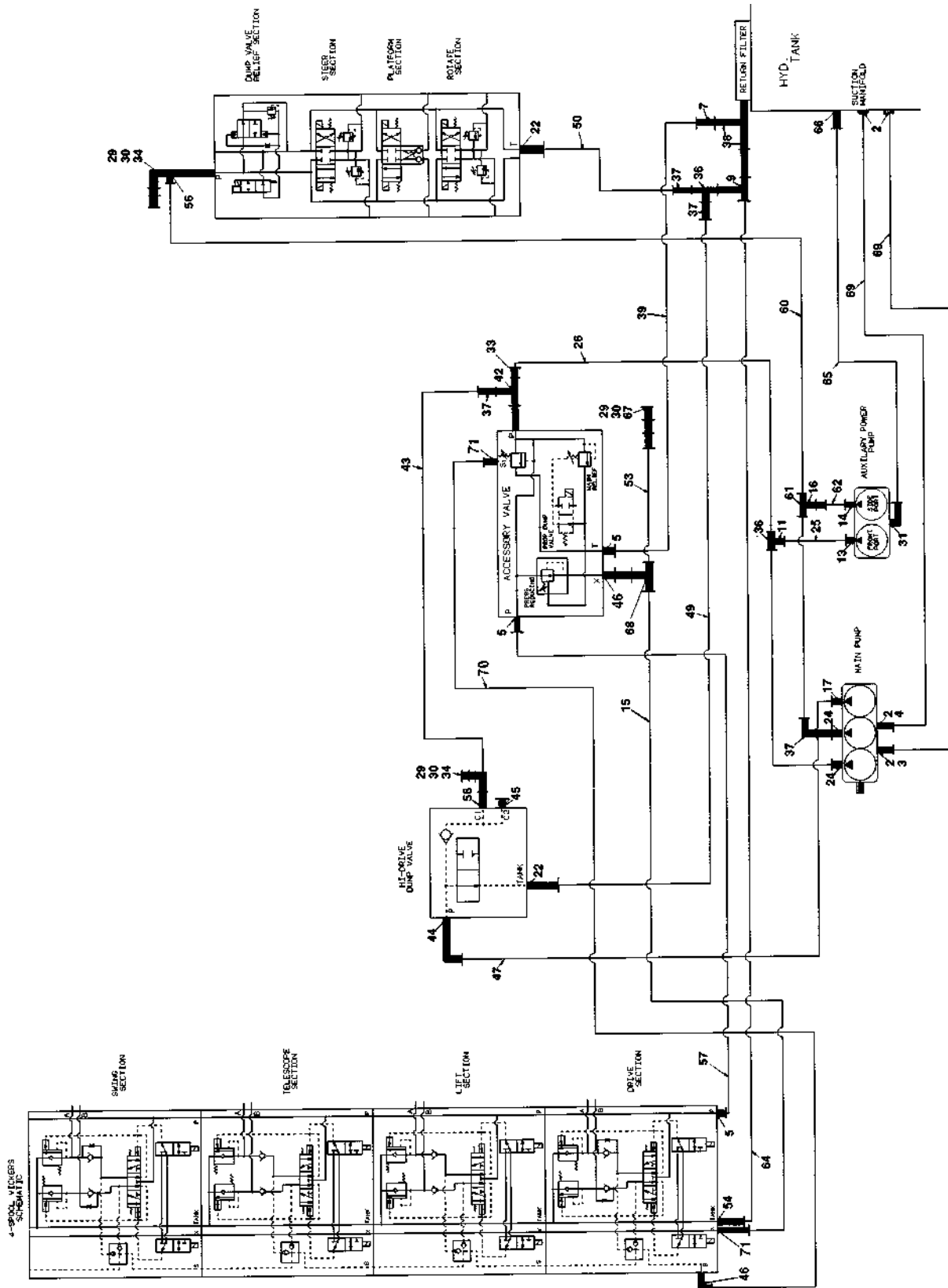

SECTION 6 HYDRAULICS

FIGURE 6-8. HYDRAULIC DIAGRAM - PUMP

FIG & ITEM #	PART NUMBER	DESCRIPTION	QTY.	REV.
	2791438	HYDRAULIC DIAGRAM - PUMP	Ref.	8
1	Not Used			
2	1320031	Clamp	8	
3	2220809	Fitting, 45°	1	
4	2220808	Fitting, 45°	1	
5	2220451	Fitting, Straight	3	
6	Not Used			
7	2220347	Fitting, Straight	1	
8	Not Used			
9	2220681	Fitting, Tee	1	
10	0100020	Sealant, Pipe (Not Shown)	A/R	
11	2220621	Fitting, Reducer	1	
12	Not Used			
13	2220371	Fitting, Straight	1	
14	2220466	Fitting, 90°	1	
15	2750902	Hose	1	
16	2220618	Fitting, Reducer	1	
17	2220375	Fitting, Straight	1	
18	Not Used			
19	Not Used			
20	Not Used			
21	Not Used			
22	2220373	Fitting, Straight	2	
23	Not Used			
24	4640575	Valve, Check	2	
25	2750786	Hose	1	
26	2751320	Hose	1	
27	Not Used			
28	Not Used			
29	2220428	Fitting, Quick Disconnect	3	
30	2220429	Cap, Dust	3	
31	2220114	Fitting, 90°	1	
32	Not Used			
33	2220407	Fitting, 90°	1	
34	2220820	Fitting, 90°	1	
35	Not Used			
36	2220700	Fitting, Tee	2	
37	2220622	Fitting, Reducer	4	
38	2220696	Fitting, Reducer	2	
39	2751617	Hose	1	
40	Not Used			
41	Not Used			
42	2220738	Fitting, Tee	1	
43	2750968	Hose	1	
44	2220596	Fitting, 90°	1	
45	2220237	Fitting, Plug	1	
46	2220582	Fitting, Straight	2	
47	2750777	Hose	1	

SECTION 6 HYDRAULICS

FIGURE 6-8. HYDRAULIC DIAGRAM - PUMP (CONTINUED)

FIG & ITEM #	PART NUMBER	DESCRIPTION	QTY.	REV.
48	Not Used			
49	2750977	Hose	1	
50	2750757	Hose	1	
51	Not Used			
52	Not Used			
53	2751015	Hose	1	
54	2220435	Fitting, Straight	1	
55	Not Used			
56	2180491	Fitting, Modified 90°	2	
57	2750872	Hose	1	
58	Not Used			
59	Not Used			
60	2750777	Hose	1	
61	2220385	Fitting, Tee	1	
62	2751021	Hose	1	
63	Not Used			
64	2751353	Hose	1	
65	2750129	Hose	1	
66	2220072	Hose	1	
67	2220414	Fitting, Straight	1	
68	2220605	Fitting, Tee	1	
69	2720280	Hose, Suction 1 1/2" x 70"	2	
70	2750889	Hose	1	
71	2220472	Fitting, 90°	2	

SECTION 6 HYDRAULICS

FIGURE 6-8. HYDRAULIC DIAGRAM - PUMP (CONTINUED)

FIG & ITEM #	PART NUMBER	DESCRIPTION	QTY.	REV.

SECTION 6 HYDRAULICS

FIGURE 6-9. HYDRAULIC DIAGRAM - ROTATE

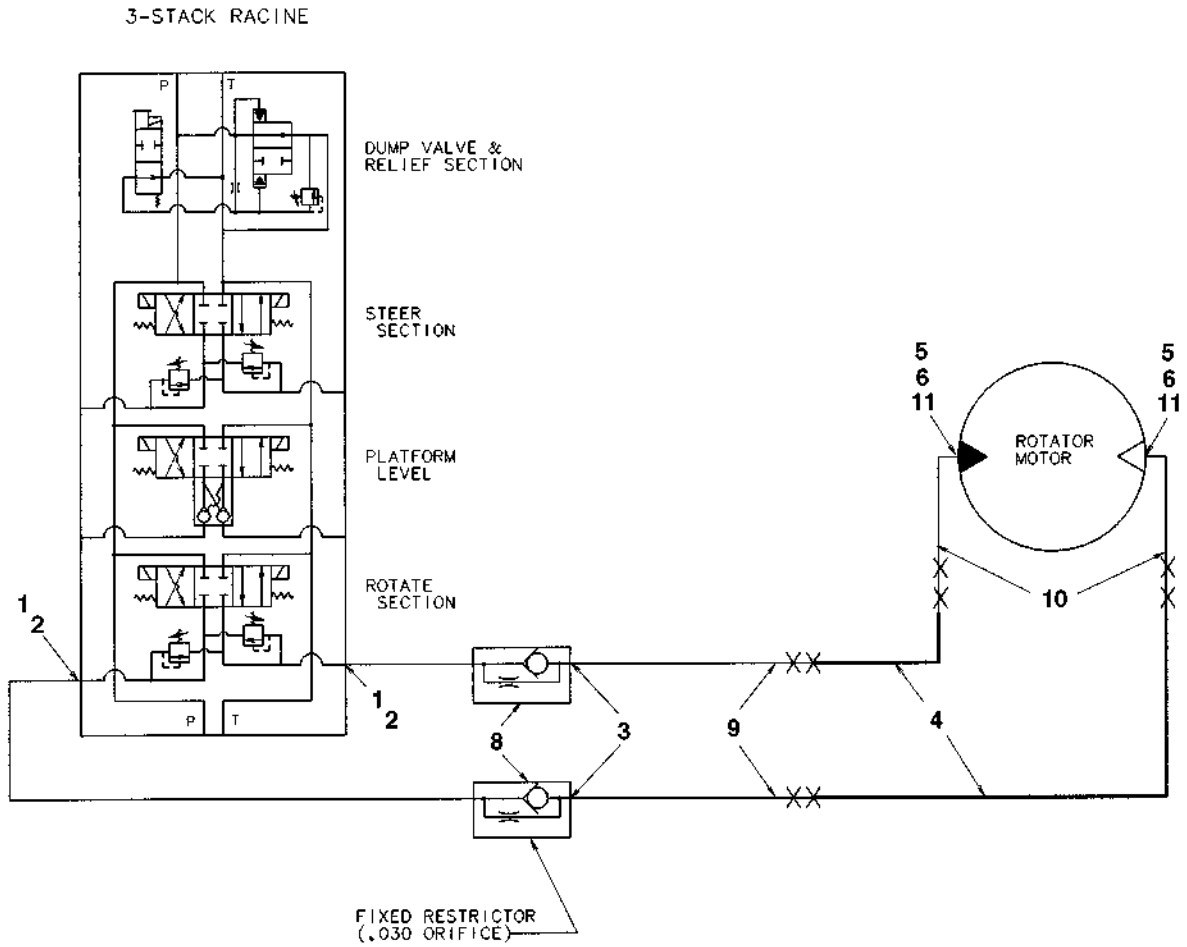

X-DENOTES A MALE FLARE HOSE END

SECTION 6 HYDRAULICS

FIGURE 6-9. HYDRAULIC DIAGRAM - ROTATE

FIG & ITEM #	PART NUMBER	DESCRIPTION	QTY.	REV.
	2791604	HYDRAULIC DIAGRAM - ROTATE (100HX & 110HX)	Ref.	2
	2791987	HYDRAULIC DIAGRAM - ROTATE (100HX+10 & 110HXER)	Ref.	2
1	2220446	Fitting	2	
2	2220438	Fitting, Nipple	2	
3	2220416	Fitting, Straight	2	
4	4563167	Tube	2	
5	2220609	Fitting, Reducer	2	
6	2220497	Fitting, Straight	2	
7	0100020	Sealant, Pipe (Not Shown)	A/R	
8	4640383	Valve, Restrictor	2	
9	2751455	Hose	2	
10	2751919	Hose (100HX & 110HX)	2	
	2752452	Hose (100HX+10 & 110HXER)	2	
11	2220507	Fitting, 90° (100HX+10 & 110HXER Only)	2	

SECTION 6 HYDRAULICS

FIGURE 6-10. HYDRAULIC DIAGRAM - SEQUENCE LINE

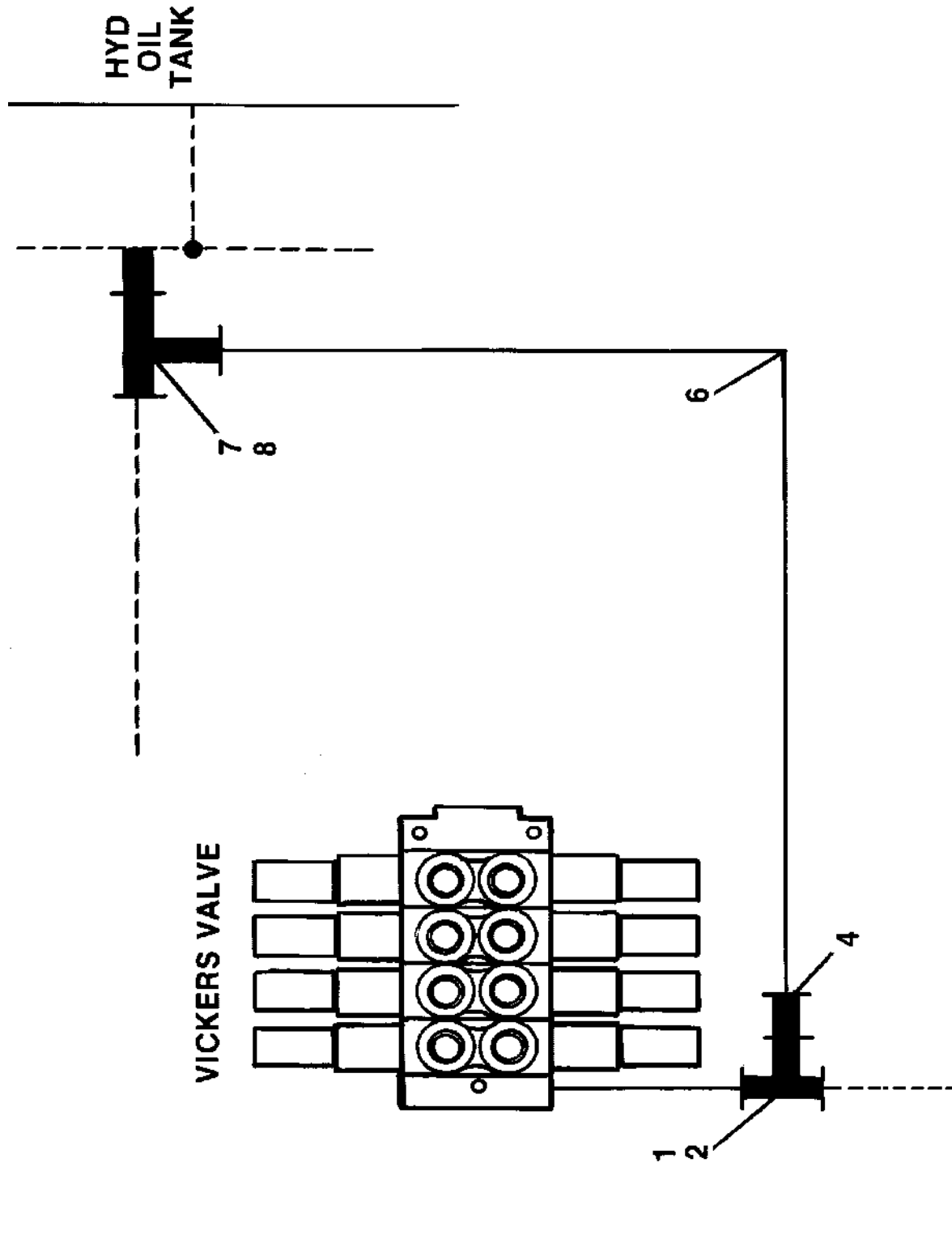

SECTION 6 HYDRAULICS

FIGURE 6-10. HYDRAULIC DIAGRAM - SEQUENCE LINE

FIG & ITEM #	PART NUMBER	DESCRIPTION	QTY.	REV.
	2791703	HYDRAULIC DIAGRAM - SEQUENCE LINE	Ref.	A
1	2220582	Fitting, Straight	1	
2	2220605	Fitting, Tee	1	
3	Not Used			
4	2220909	Orifice (.015)	1	
5	Not Used			
6	2751015	Hose	1	
7	2220684	Fitting, Tee	1	
8	2220250	Fitting, Tee	1	

SECTION 6 HYDRAULICS

FIGURE 6-11. HYDRAULIC DIAGRAM - SWING

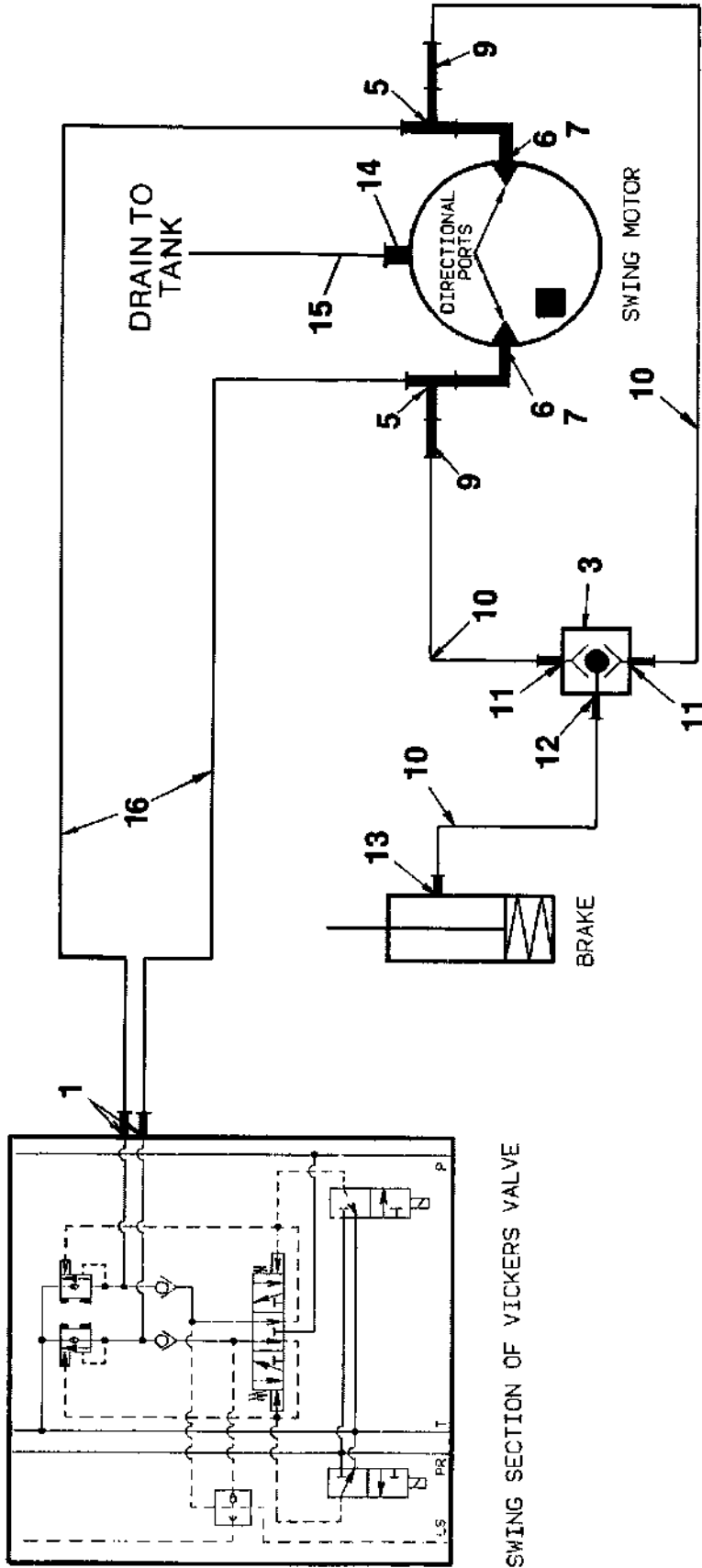

SWING SECTION OF VICKERS VALVE

SECTION 6 HYDRAULICS

FIGURE 6-11. HYDRAULIC DIAGRAM - SWING

FIG & ITEM #	PART NUMBER	DESCRIPTION	QTY.	REV.
	2791426	HYDRAULIC DIAGRAM - SWING	Ref.	3
1	2220577	Fitting, Straight	2	
2	0100020	Sealant, Pipe (Not Shown)	A/R	
3	4640013	Valve, Shuttle	1	
4	Not Used			
5	2220635	Fitting, Tee	2	
6	2180377	Fitting, Modified	2	
7	2180270	Orifice (.12)	2	
8	0100011	Loctite (Not Shown)	A/R	
9	2220609	Fitting, Reducer	2	
10	2750900	Hose	3	
11	2220416	Fitting, 90°	2	
12	2220414	Fitting, Straight	1	
13	2220466	Fitting, 90°	1	
14	2220415	Fitting, 90°	1	
15	2751014	Hose	1	
16	2750999	Hose	2	

SECTION 6 HYDRAULICS

FIGURE 6-12. HYDRAULIC DIAGRAM - TELESCOPE

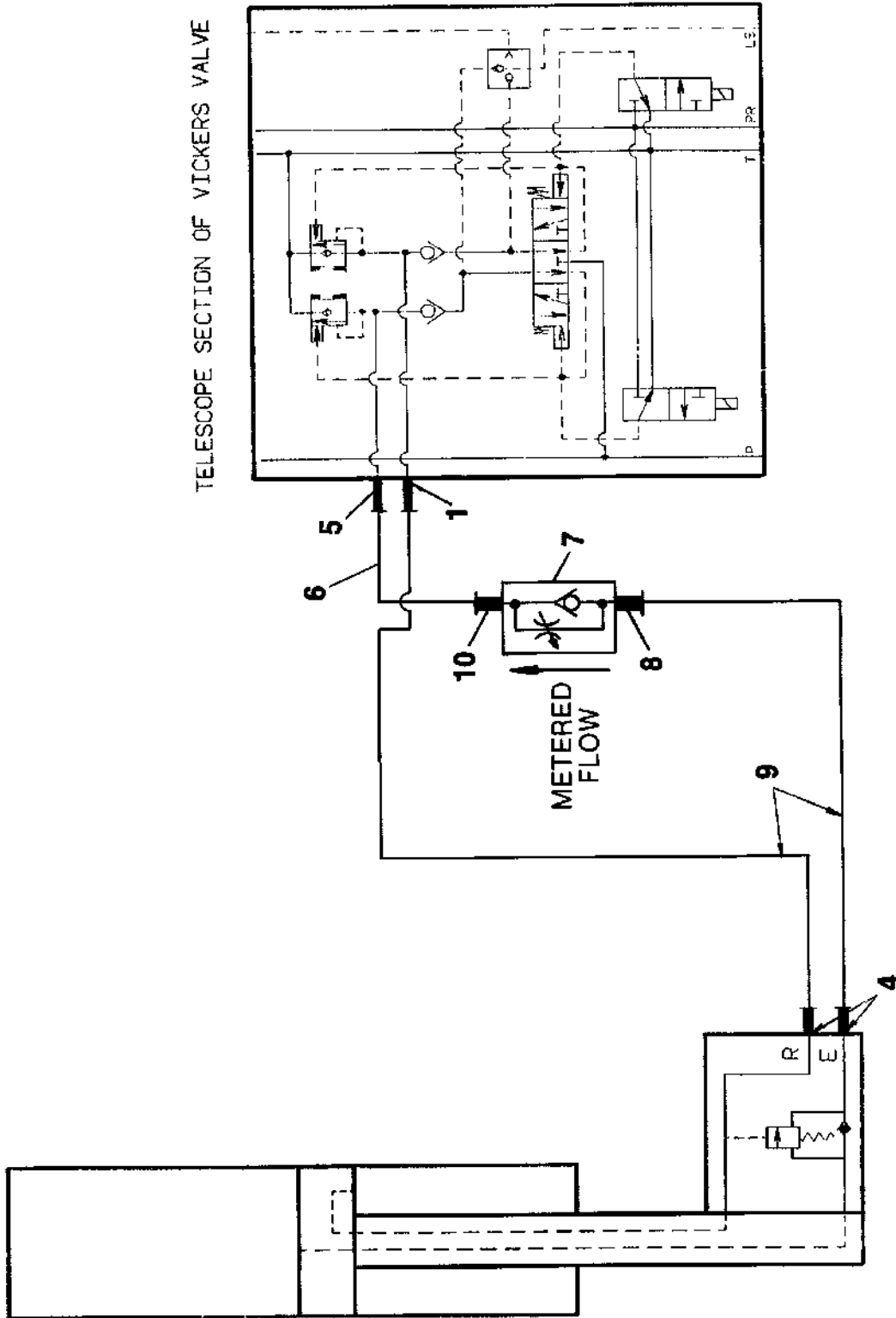

SECTION 6 HYDRAULICS

FIGURE 6-12. HYDRAULIC DIAGRAM - TELESCOPE

FIG & ITEM #	PART NUMBER	DESCRIPTION	QTY.	REV.
	2791427	HYDRAULIC DIAGRAM - TELESCOPE	Ref.	4
1	2220577	Fitting, Straight	1	
2	0100020	Sealant, Pipe (Not Shown)	A/R	
3	Not Used			
4	2220492	Fitting, Straight	2	
5	2220221	Fitting, Reducer	1	
6	2220758	Fitting, Straight	1	
7	4640216	Valve, Color Flow	1	
8	2220343	Fitting, Straight	1	
9	2752163	Hose	2	
10	2220396	Fitting, Straight	1	

SECTION 6 HYDRAULICS

**S
E
C
T
I
O
N

6

H
Y
D
R
A
U
L
I
C
S**

FIGURE 6-12. HYDRAULIC DIAGRAM - TELESCOPE (CONTINUED)

FIG & ITEM #	PART NUMBER	DESCRIPTION	QTY.	REV.

SECTION 7 ELECTRICAL

TABLE OF CONTENTS

FIGURE	DESCRIPTION	PAGE
7-1	ELECTRICAL DIAGRAM LIST	7-2
7-2	WIRING SCHEMATIC - PLATFORM.	7-8
7-3	WIRING SCHEMATIC - STANDARD.	7-10

SECTION 7 ELECTRICAL

FIGURE 7-1. ELECTRICAL DIAGRAM LIST

FIG & ITEM #	PART NUMBER	DESCRIPTION	QTY.	REV.
7-1		ELECTRICAL DIAGRAM LIST Note: Diagrams with asterisk (*) are shown in the following pages. Diagrams not shown are available from the JLG Service Department.	Ref.	
		Alarm Wiring Diagrams	Ref.	
		Prior to April 1993		
	4931947/1281985	Back-up Alarm Wiring Diagram	Ref.	G/G
	4931947/1281985	Descent Alarm Wiring Diagram	Ref.	G/G
	4932595/1281985	Motion Alarm Wiring Diagram	Ref.	A/G
	4931947/1281985	Swing Alarm Wiring Diagram	Ref.	G/G
	4932032	Tilt Alarm Wiring Diagram	Ref.	A
	4931947/1281985	Travel Alarm Wiring Diagram	Ref.	G/G
	0610091	Card, Circuit (All except Motion and Tilt)	1	
	3740049	Relay	1	
	3990010	Diode - 6 Amp	1	
	0140026	Alarm (Tilt Only - Located at Console)	1	
		April 1993 to Present		
	4932637/1282091	Back-up Alarm Wiring Diagram	Ref.	2/A
	4932637/1282091	Descent Alarm Wiring Diagram	Ref.	2/A
	4932639/1282091	Motion Alarm Wiring Diagram	Ref.	2/A
	4932637/1282091	Swing Alarm Wiring Diagram	Ref.	2/A
	See Note	Tilt Alarm Wiring Diagram (Note: See Standard Wiring Diagram)	Ref.	
	4932637/1282091	Travel Alarm Wiring Diagram	Ref.	2/A
	0610104	Card, Circuit (All except Motion and Tilt)	1	
	3740049	Relay (Motion Only)	1	
	3990010	Diode - 6 Amp (Motion Only)	1	
	1060641	Cable, Electrical - 16/2 (Motion Only)	8ft/2.4m	
	0140026	Alarm (Tilt Only - Located at Console)	1	
	1540002	Capacitor (Tilt Only - Located at Console)	1	
	4932635	Australian Spec Wiring Diagram	Ref.	D
	4932877	Axle Jack Control Functions Wire Diagram (Dual Jacks Only)	Ref.	—
	1060042	Cable, Electrical - 16/5 (Collector Ring to MTB)	10ft/3m	
	3990010	Diode 6 Amp	6	
	3740049	Relay, Bosch	1	
	4921877	Harness (Collector Ring to Frame Mounted Controls and Valve)	1	
		Beacon/Strobe Light Wiring Diagrams	Ref.	
	4932029	Beacon Light - Platform Mounted (Prior to September 1991)	Ref.	—
	1281671	Beacon Light - Platform Mounted (September 1991 to Present)	Ref.	D
	4932029	Beacon/Strobe Light - Turntable Mounted (Prior to January 1995)	Ref.	—
	1282370	Beacon/Strobe Light - Turntable Mounted (January 1995 to Present)	Ref.	C

SECTION 7 ELECTRICAL

FIGURE 7-1. ELECTRICAL DIAGRAM LIST (Continued)

FIG & ITEM #	PART NUMBER	DESCRIPTION	QTY.	REV.
		Boom Cables	A/R	
	1060515	Cable, Electrical - 12/4	131ft/40m	
	1060516	Cable, Electrical - 16/30	131ft/40m	
		Boom Indicator Pendulum Wiring Diagrams:	Ref.	
	Not Required	1st Generation (Not Used on Euro Spec Machines)	Ref.	
	4931960	2nd Generation (Nineth Machine to Mid 1989)	Ref.	A
	4931961	3rd/4th/5th Generations (Mid 1989 to Present)	Ref.	B
	3730024	Resistor - 100 Ohms	1	
	3730040	Resistor, Variable - 500 Ohms (2nd Generation Only)	1	
	4932608	Broken Fly Chain Limit Switch (German/Austrian Spec Prior to S/N 28224)	Ref.	B
	4932099	Eight Meter (8m) Drive Cutout Wiring Diagram (Dutch & German Spec) (Prior to S/N 28224)	Ref.	A
	1060300	Cable, Electrical - 16/3	15ft/4.6m	
	3740057	Relay (Located in Ground Control Box)	1	
	4120012	Socket, Relay (Located in Ground Control Box)	1	
	3740066	Spring, Relay (Located in Ground Control Box)	1	
	4931671	Engine Distress Wiring Diagram - Deutz Engines (Prior to September 1994)	Ref.	B
	4360179	Switch, Temperature	1	
	4360089	Flasher	1	
	3740013	Relay	1	
	4360065	Switch, Pressure	1	
	2920034	Lamp (Located at Platform Console)	1	
	3251695	Nameplate - Engine Distress	1	
	0255568	Engine Distress Wiring Diagram - Deutz Engines (September 1994 to Present)	Ref.	—
	2920026	Lamp, Indicator	1	
	2920029	Bulb, Light	1	
	4360065	Switch, Oil Pressure	1	
	4360179	Switch, Temperature	1	
	3740049	Relay	1	
	0251683	Engine Run Light Wiring Diagram - Deutz Engines	Ref.	B
	2920027	Lamp, Indicator	1	
	2920029	Bulb, Light	1	
	4360037	Switch, Pressure	1	
	1702528	Decal - Engine Run	1	
	4932892	Engine Shut-Down Wiring Diagram - Deutz Engines	Ref.	—

SECTION 7 ELECTRICAL

FIGURE 7-1. ELECTRICAL DIAGRAM LIST (Continued)

FIG & ITEM #	PART NUMBER	DESCRIPTION	QTY.	REV.
	4932492	French Spec Wiring Diagram (Prior to S/N 28224)	Ref.	C
	1693405	Relay, Timer	1	
	1693406	Clip, Retainer	1	
	1692927	Socket, Relay	1	
	4931858	Generator Wiring Diagram - 110V (Deutz)	Ref.	A
	3990001	Diode - 3.5 Amp	1	
	0252928	Heaters Wiring Diagram	Ref.	F
	4932312	Horizontal Drive Cutout (Italian Spec) (Prior to S/N 8224)	Ref.	A
	3740057	Relay (Located in Ground Control Box)	1	
	4120012	Socket, Relay (Located in Ground Control Box)	1	
	3740066	Spring, Relay (Located in Ground Control Box)	1	
	4931941	Lights Wiring Diagram - Headlights and Taillights (Prior to January 1995)	Ref.	E
	4360232	Breaker, Circuit - 15 Amp	1	
	3740049	Relay - SPDT	1	
	4360199	Switch, Toggle	1	
	4460052	Connector, Strain Relief	1	
	3300047	Nut, Conduit	1	
	3251019	Nameplate - Lights On/Off	1	
	1282370	Lights Wiring Diagram (January 1995 to Present)	Ref.	C
	4933007	Load Sensing System (French Spec)	Ref.	1/A
	0255274	Low Oil Pressure Shutdown Wiring Diagram	Ref.	3
	2920026	Lamp, Indicator	1	
	2920029	Bulb, Light	1	
	4360065	Switch, Oil Pressure	1	
	3740049	Relay (In Platform Console Box)	1	
	3990010	Diode - 6 Amp	1	
	3740080	Relay (In Platform Console Box)	1	
	3252074	Nameplate - Engine Distress	1	
	1692883	Manual Descent Wiring Diagram (French & Italian Spec) (Prior to January 1993)	Ref.	C
	4932607	Manual Descent Wiring Diagram (French & Italian Spec) (January 1993 to Present)	Ref.	2
	3990001	Diode	3	
	3990010	Diode (January 1993 to Present)	1	
	3740049	Relay	1	
	3740274	Switch, Push Button	1	
	1701746	Decal - Manual Descent	1	
	0252917	Oil Cooler Wiring Diagram	Ref.	3

SECTION 7 ELECTRICAL

FIGURE 7-1. ELECTRICAL DIAGRAM LIST (Continued)

FIG & ITEM #	PART NUMBER	DESCRIPTION	QTY.	REV.
		Platform Wiring Diagrams (Prior to S/N 28224)	Ref.	
	4932100	Wiring Diagram - Start	Ref.	
	4932101	Wiring Diagram - Tele	Ref.	
	4932102	Wiring Diagram - Swing	Ref.	
	4932103	Wiring Diagram - Lift	Ref.	
	4932104	Wiring Diagram - Auxiliary Power	Ref.	
	4932112	Wiring Diagram - Level	Ref.	
	4932115	Wiring Diagram - Overload Warning Alarm	Ref.	
	4932105	Wiring Diagram - High Engine	Ref.	
	4932106	Wiring Diagram - Steer	Ref.	
	4932108	Wiring Diagram - Drive	Ref.	
	4932109	Wiring Diagram - Rotate	Ref.	
	4932110	Wiring Diagram - 2 Speed	Ref.	
	4932113	Wiring Diagram - Horn	Ref.	
	4932114	Wiring Diagram - Hi-Drive	Ref.	
	4932117	Wiring Diagram - Axles Set Light	Ref.	
	4932119	Wiring Diagram - 0# Light Indicator	Ref.	
	4932120	Wiring Diagram - 500# Light Indicator	Ref.	
	4932107	Wiring Diagram - 3° Tilt	Ref.	
	4932116	Wiring Diagram - Emergency Stop	Ref.	
	4932118	Wiring Diagram - Footswitch	Ref.	
	4932111	Wiring Diagram - Bang-Bang Dump (100HX & 110HX)	Ref.	
	4932122	Wiring Diagram - Bang-Bang Dump (100HX+10 & 110HXER)	Ref.	
	4932121	Wiring Diagram - Power Distribution (100HX & 110HX)	Ref.	
	4932123	Wiring Diagram - Power Distribution (100HX+10 & 110HXER)	Ref.	
	4932124	Wiring Diagram - Extend-A-Reach (100HX+10 & 110HXER Only)	Ref.	
	4932125	Wiring Diagram - Broken Chain Light	Ref.	
		Platform Wiring Diagrams (S/N 28224 to Present)	Ref.	
	4932952	100HX & 110HX	Ref.	3/C
	4932953	100HX+10 & 110HXER	Ref.	2/C
	3990010	Diode 6 Amp	11	
	1060012	Cable, Electrical - 12/4	7.5ft/2.3m	
		Platform Bumper Wiring Diagram	Ref.	
	1282197	Wiring Diagram - Chain Mounted (Soft-Touch) Bumper	Ref.	G
	4932059	Wiring Diagram - Welded on Bumper	Ref.	A
		Platform Gate Interlock Wiring Diagram (French Spec) (Prior to S/N 28224)	Ref.	G
	3740049	Relay (Located in Ground Control Box)	1	
	0960239	Bushing	2	
	1060300	Cable, Electrical - 16/3	15ft/4.6m	

SECTION 7 ELECTRICAL

SECTION 7 ELECTRICAL

FIGURE 7-1. ELECTRICAL DIAGRAM LIST (Continued)

FIG & ITEM #	PART NUMBER	DESCRIPTION	QTY.	REV.
		Platform Work Lights Wiring Diagram	Ref.	
	2900068	Wiring Diagram (Prior to November 1992)	Ref.	F
	2920013	Worklight	2	
	0253686	Wiring Diagram (November 1992 to May 1995)	Ref.	—
	0253987	Wiring Diagram (May 1995 to Present)	Ref.	C
	0254748	Wiring Diagram with Padded Platform	Ref.	2
	2920111	Worklight	2	
		Standard Wiring Diagrams	Ref.	
		Deutz Engine Machines	Ref.	
	4932087	100HX & 110HX Built Prior to S/N 28224	Ref.	M
	4932954	100HX & 110HX Built S/N 28224 to Present	Ref.	2/D
	4932090	100HX+10 & 110HXER Prior to S/N 28224	Ref.	M
	4932955	100HX+10 & 110HXER S/N 28224 to Present	Ref.	2/C
	4460226	Socket	12	
	4460225	Plug, 6 Position	1	
	4460326	Plug, 3 Position	1	
	4460321	Plug, 4 Position	1	
	4921140	Harness, Engine	1	C
	3990010	Diode - 6 Amp	1	
	4460277	Strip, Terminal - 14 Position	1	
	4460264	Terminal, Buss Bar - 2 Position	1	
	4921141	Harness, MTB to Engine Terminal Strip	1	F
	4921142	Harness, Valve	1	I
	3990010	Diode - 6 Amp	2	
	3730095	Resistor - 7.5 Ohm	1	
	3730099	Resistor	1	
	1540003	Condensor, Capacitor	1	
	1060300	Cable, Electrical -16/3 (To Axles Limit Switches)	15ft/4.6m	
	1060016	Cable, Electrical -16/3 (To Horizontal Limit Switch)	15ft/4.6m	
	1060300	Cable, Electrical -16/3 (To Overload Switches)	16ft/4.9m	
	1060042	Cable, Electrical -16/5 (To Boom Angle Indicator)	15ft/4.6m	
	1060300	Cable, Electrical -16/3 (To Load Management)	15ft/4.6m	
	1870001*	Standard Wiring Schematic	Ref.	C
	4932570	TUV Monitoring System Wiring Diagram (Optional on German TUV Machines)	Ref.	E

SECTION 7 ELECTRICAL

SECTION 7 ELECTRICAL

FIGURE 7-1. ELECTRICAL DIAGRAM LIST (Continued)

FIG & ITEM #	PART NUMBER	DESCRIPTION	QTY.	REV.

SECTION 7 ELECTRICAL

FIGURE 7-2. WIRING SCHEMATIC - PLATFORM (SHEET 1 OF 2).

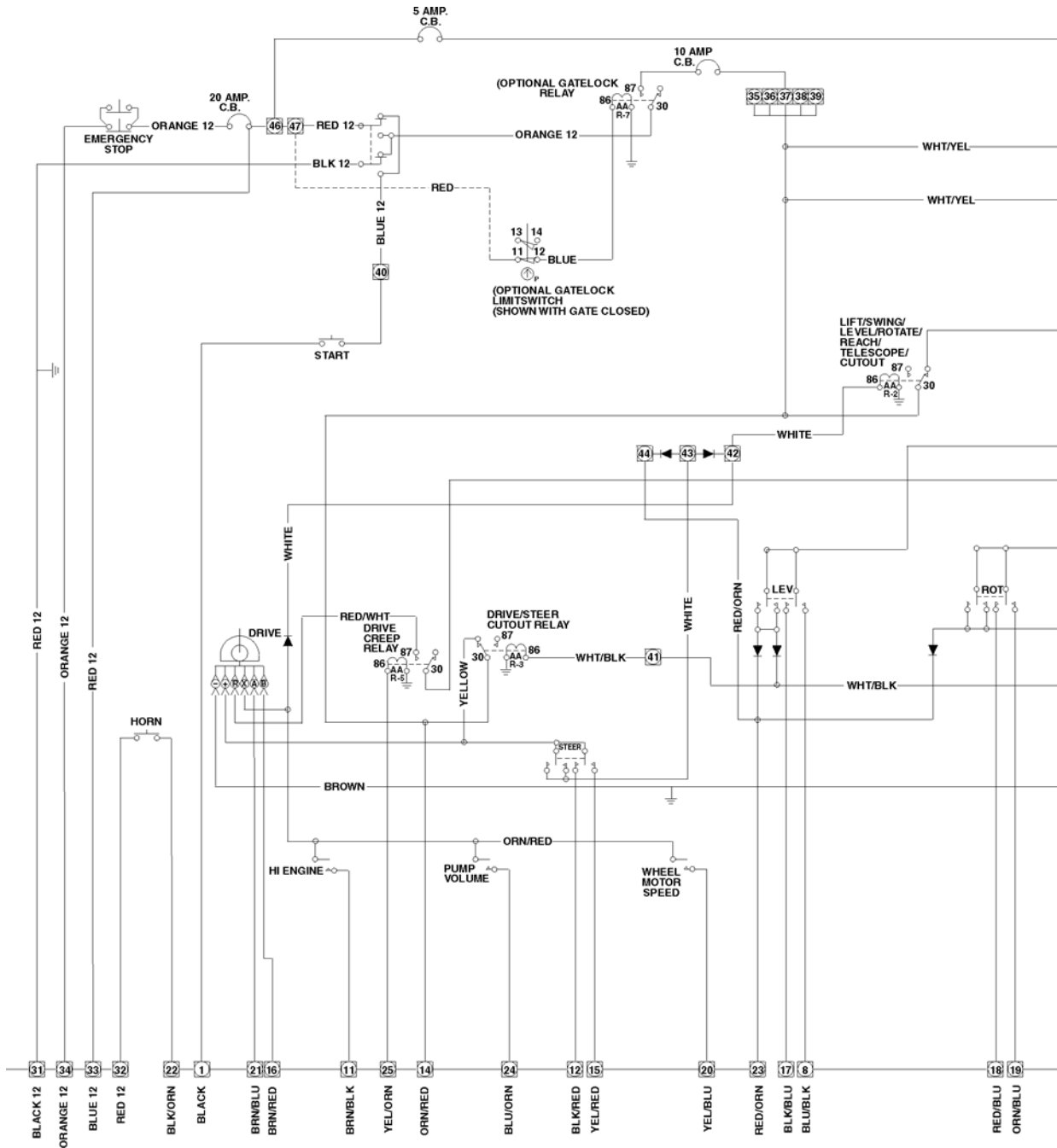

SECTION 7 ELECTRICAL

FIGURE 7-2. WIRING SCHEMATIC - PLATFORM (SHEET 2 OF 2).

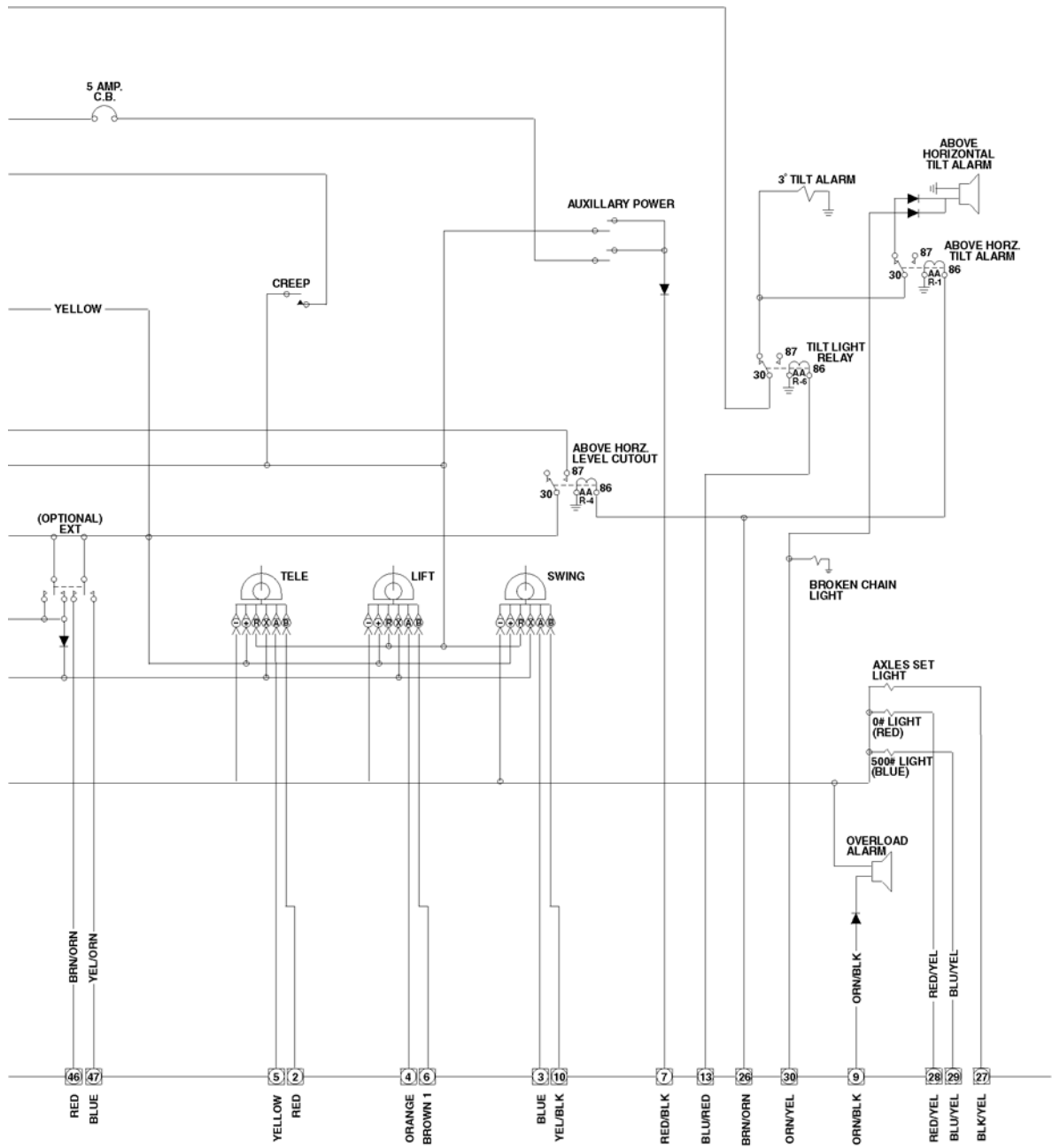

SECTION 7 ELECTRICAL

FIGURE 7-3. WIRING SCHEMATIC - STANDARD (SHEET 1 OF 2).

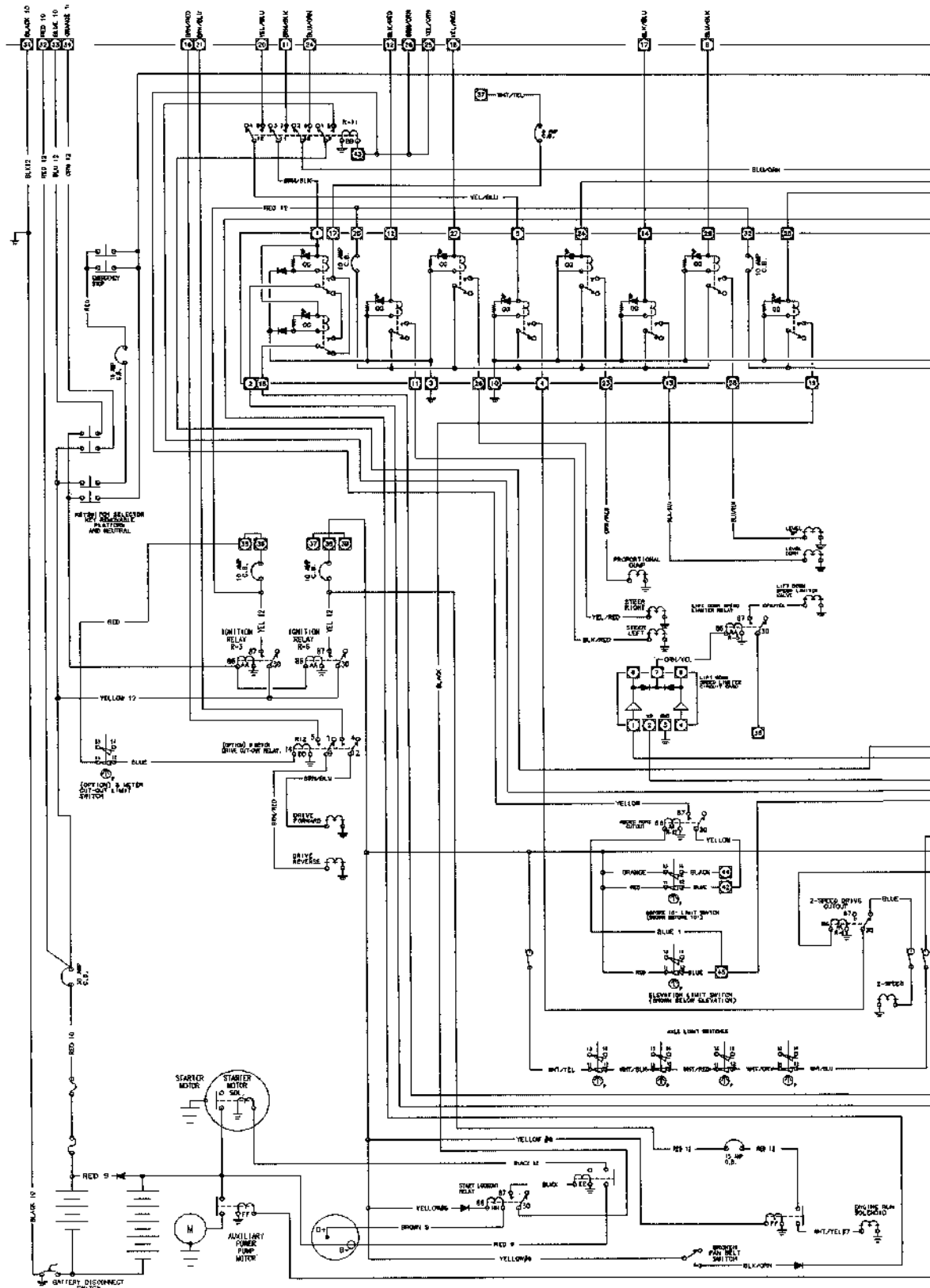

SECTION 7 ELECTRICAL

FIGURE 7-3. WIRING SCHEMATIC - STANDARD (SHEET 2 OF 2).

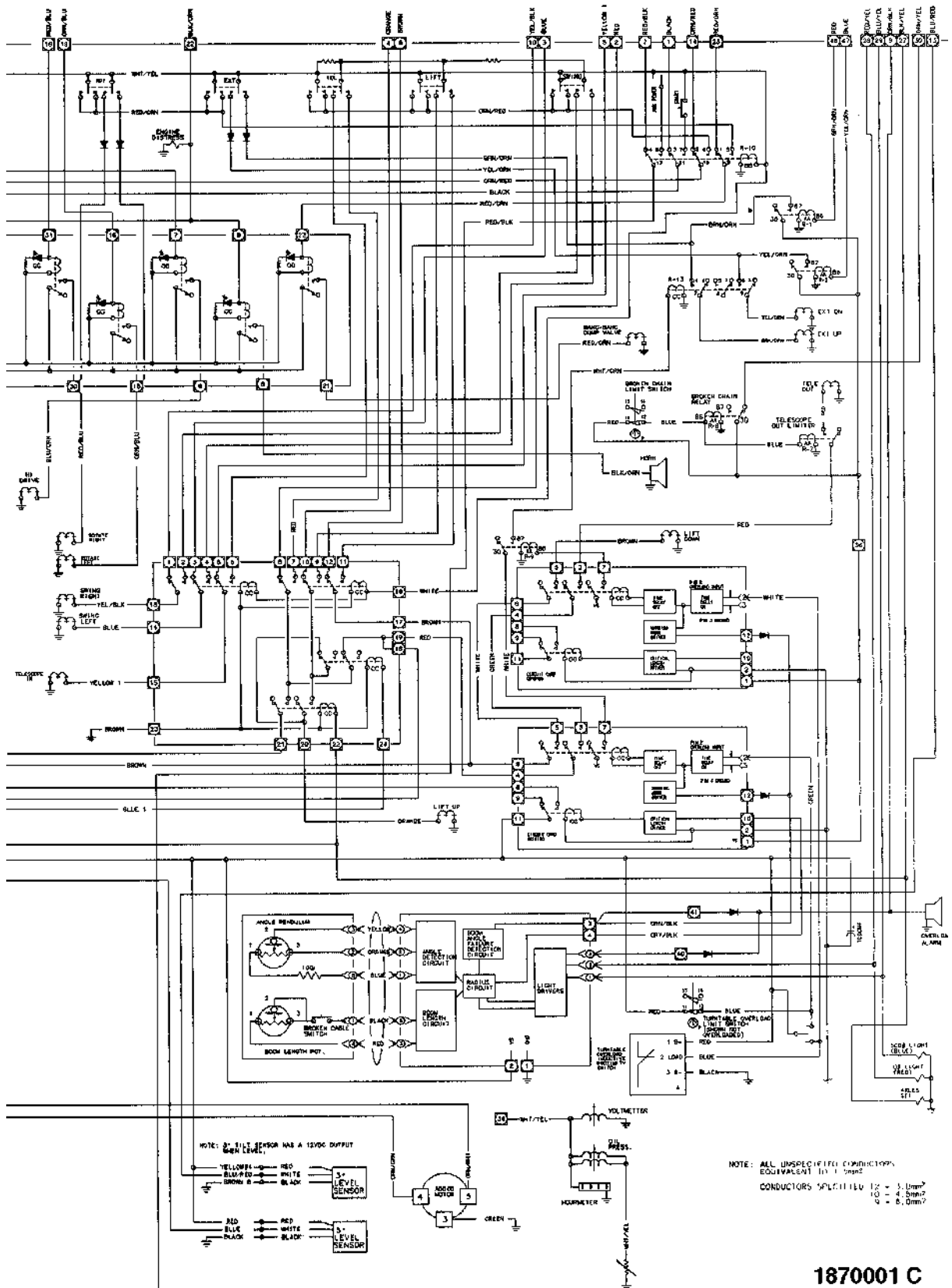

1870001 C

SECTION 7 ELECTRICAL

**S
E
C
T
I
O
N

7

E
L
E
C
T
R
I
C
A
L**

THIS PAGE INTENTIONALLY LEFT BLANK

SECTION 8 DECALS

TABLE OF CONTENTS		
FIGURE	DESCRIPTION	PAGE
8-1	DECALS INSTALLATION - BROWN DECALS.....	8-2
8-2	DECALS INSTALLATION - BLACK DECALS.....	8-8

SECTION 8 DECALS

FIGURE 8-1. DECALS INSTALLATION - BROWN DECALS

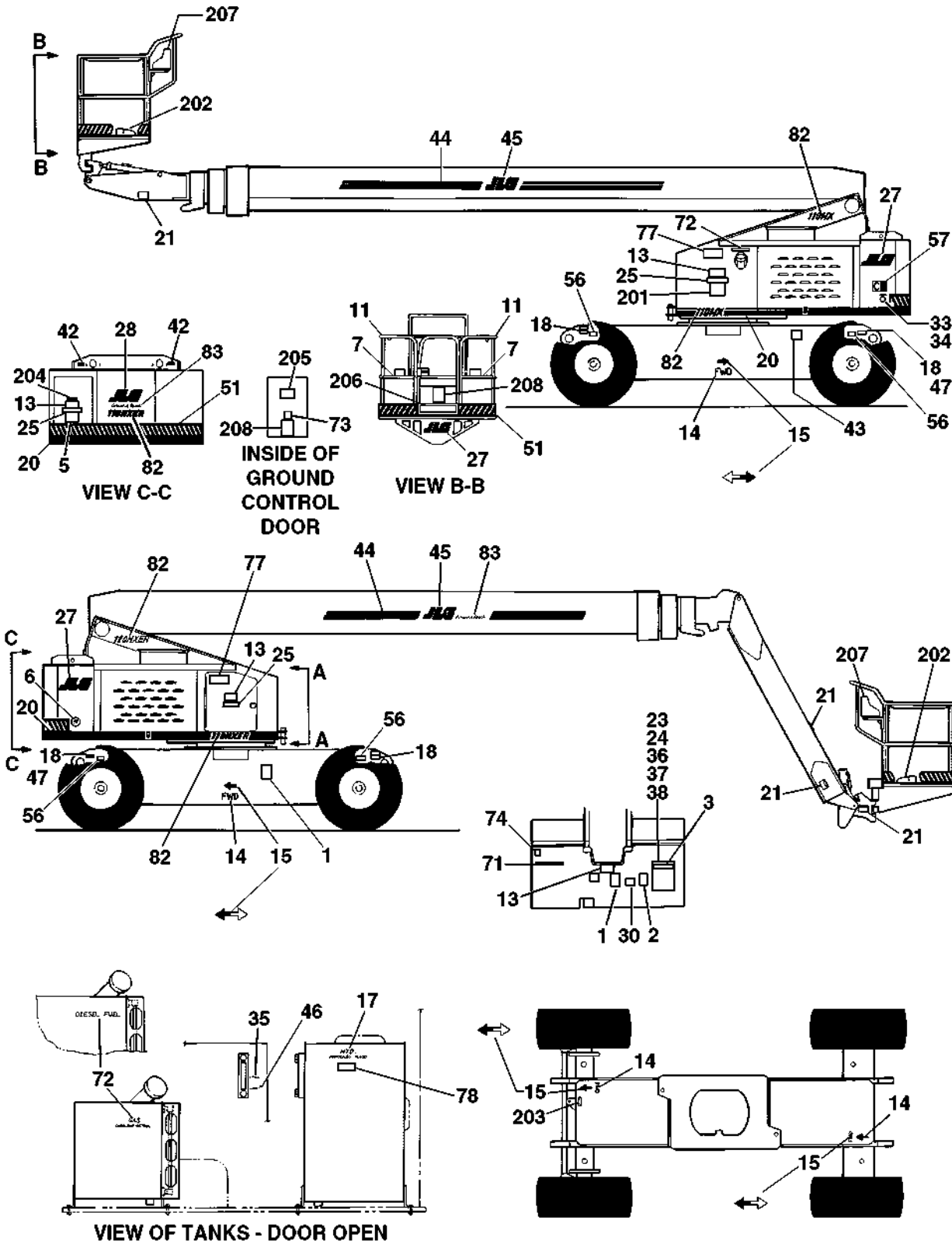

SECTION 8 DECALS

FIGURE 8-1. DECALS INSTALLATION - BROWN DECALS

FIG & ITEM #	PART NUMBER	DESCRIPTION	QTY.	REV.
		DECALS INSTALLATION - BROWN (STANDARD PARTS)	Ref.	
1	Not Available	Nameplate - Serial Number (Location Will Vary)	1	
2	1700584^	Decal - Patent	1	
3		Decal - Manual Options:	1	
	1700157	Decal (Prior to August 1991)		
	1701509^	Decal (August 1991 to Present)		
4	Not Used			
5	1700643	Decal - Caution (Prior to August 1991) (110HXER & 100HX+10 Only)	1	
6	3251813	Decal - USA (Location Will Vary) (November 1989 to August 1995 Only)	1	
7	1700477	Decal - Attach Belt (Prior to August 1991)	2	
8 to 10	Not Used			
11	1700476	Decal - No Hands (Prior to August 1991)	2	
12	Not Used			
13		Decal - Crushing Options:	4	
	1700585	Decal (Prior to August 1991)		
	1701518^	Decal (August 1991 to Present)		
14	1700977	Decal - FWD (Brown) (Prior to August 1991 Only)	4	
15		Decal - Arrow Options:	4	
	1700978	Decal - Arrow (Brown) (Prior to August 1991)		
	1701501^	Decal - Arrow (Black/White) (August 1991 to Present)		
16	Not Used			
17		Decal - Hydraulic Options:	1	
	1700419	Decal - Hydraulic (Brown) (Prior to August 1991)		
	1701504^	Decal - Hydraulic (August 1991 to Present)		
18		Decal - Tie-Down/Lift Up Options:	A/R	
	1700976	Decal - Tie-Down (Brown) (Prior to August 1991)	4	
	1700975	Decal - Lift Here (Brown) (August 1991 to Present)	2	
	1701500	Decal - Lift Here (August 1991 to Present)	4	
	1702300	Decal - Tie-Down (August 1991 to Present)	4	
19	Not Used			
20		Decal - Brown/Orange Stripe Options:	A/R	
	1700431	Decal (Prior to September 1995)	32ft/9.75m	
	1701703^	Decal (September 1995 to Present)	27ft/8.23m	
21		Decal - Crushing Options:	A/R	
	1700640	Decal (Prior to August 1991)		
	1701518	Decal (August 1991 to Present)		
22	3820001	Rivet (Not Shown)	A/R	
23	0641408	Bolt 1/4"-20NC x 1"	1	
24	1060279	Cable, Lanyard	1	
25	1700580	Decal - Electrocution Hazard (Prior to August 1991 Only)	3	
26	Not Used			
27	1700981	Decal - JLG (Brown) (Prior to September 1995 Only)	3	
28		Decal - JLG Options:	1	
	1700981	Decal - JLG (Brown) (Prior to September 1995)		
	1701702^	Decal - JLG (Brown) (September 1995 to Present)		

SECTION 8 DECALS

FIGURE 8-1. DECALS INSTALLATION - BROWN DECALS (CONTINUED)

FIG & ITEM #	PART NUMBER	DESCRIPTION	QTY.	REV.
29	Not Used			
30	1700593	Decal - Inspection (Prior to August 1991 Only)	1	
31	Not Used			
32	Not Used			
33	0961127	Bushing, Snap	1	
34	0100010	Loctite, Adhesive	A/R	
35		Decal - Full/Add	1	
	1700756	Decal - Full/Add (Brown) (Prior to August 1991)		
	1701502^	Decal - Full/Add ((August 1991 to Present)		
36	0860520	Box, Manual Storage	1	
37	3311405	Locknut 1/4"-20NC	5	
38	4751400	Flatwasher 1/4"	6	
39	Not Used			
40	1701296	Decal - Load Management (August 1989 to August 1991)	1	
41	Not Used			
42		Decal Options:	2	
	1700975	Decal - Lift Here (Creme) (Prior to June 1991)		
	1700377	Decal - Lift Here (Brown) (June 1991 to August 1991)		
	1701500^	Decal - Tie-Down/Lift Up (August 1991 to Present)		
43	Not Available	Decal - Bar Code (September 1995 to Present)	1	
44		Decal - Brown/Orange Stripe Options:	A/R	
	1700431	Decal (100HX & 110HX) (Prior to September 1995)	24ft/7.3m	
	1700431	Decal (100HX+10 & 110HXER) (Prior to September 1995)	16ft/4.9m	
	1701704	Decal (September 1995 to Present)	27ft/8.23m	
45		Decal Options:	1	
	1700981	Decal - JLG (Brown) (Prior to September 1995)		
	1701699^	Decal - JLG Lift (Brown) (September 1995 to Present)		
46	1701503^	Decal - Hydraulic Oil Low (August 1991 to Present Only)	1	
47	1701499^	Decal - Don't Lift/Tie Down (August 1991 to Present Only)	1	
48 to 50	Not Used			
51	4420052	Decal - Safety Stripe	19ft/5.8m	
52 to 55	Not Used			
56	1703484^	Decal - Max Wheel Load	4	
57	1702928^	Decal - CE	1	
		DECALS INSTALLATION (OPTIONAL PARTS)	Ref.	
71	1701543	Decal - Fuel LP Gas	1	
72		Decal - Fuel Options:	1	
	1701542	Decal - Gas		
	1701505	Decal - Diesel (Brown)		
73		Decal - Caution LP Gas Options:	1	
	3251028	Decal (Prior to May 1994)		
	3252356	Decal (May 1994 to Present)		
74	1700818	Decal - LP Gas Liquid Withdraw System	1	

SECTION 8 DECALS

FIGURE 8-1. DECALS INSTALLATION - BROWN DECALS (CONTINUED)

FIG & ITEM #	PART NUMBER	DESCRIPTION	QTY.	REV.
75	Not Used			
76	Not Used			
77	0255580	Lifting Diagram Installation	Ref.	—
	3252449	Decal - Lifting Diagram	2	
	3820001	Rivet	8	
78	1702788	Decal - Biodegradable Hydraulic Fluid	1	
		DECALS INSTALLATION (VARIABLE PARTS)	Ref.	
	0258612	100HX	Ref.	1
	0239383	110HX Prior To August 1991	Ref.	L
	0252122	110HX August 1991 To Present	Ref.	5
	0239181	100HX+10 & 110HXER Prior To August 1991	Ref.	N
	0252656	100HX+10 & 110HXER August 1991 To Present	Ref.	4
81	Not Used			
82		Decal - Model Options (Location Will Vary):	A/R	
	Not Available	100HX Decal		
	1701059^	110HX Decal (Brown)		
	1701058	110HXER Decal (Brown) (Prior to July 1990)		
	1701380-	100HX+10 Decal (Brown) (July 1990 to Present)		
83		Decal - Extend-A-Reach Options:	A/R	
	Not Required	100HX & 110HX	0	
	1700880	100HX & 110HXER Prior to September 1990	2	
	1701375	100HX & 110HXER September 1990 to September 1995	2	
	1701431	100HX & 110HXER Prior to September 1995	2	
		DECAL INSTALLATION (VARIABLE PARTS)	Ref.	
	0252142	Australian Spec Prior To S/N 28224	Ref.	B
	0257252	Australian Spec S/N28224 To Present	Ref.	2
	0252879	Dutch Spec	Ref.	3
	0252124	French Spec	Ref.	3
	0252123	German & Austrian Specs	Ref.	2
	0252687	Italian Spec	Ref.	2
	0253314	Spanish Spec	Ref.	2
	0252142	UK Spec110HX & 100HX+10	Ref.	3
	0258629	UK Spec100HX	Ref.	2
201		Nameplate - Axle Extend/Retract Options:	1	
	3251637	Australian Spec		
	1701533^~	Dutch Spec		
	1701534	French Spec		
	1701564	German & Austrian Specs		
	1701698	Italian Spec		
	1701797	Spanish Spec		
	3251637	UK Spec 110HX & 100HX+10		
	1702301	UK Spec 100HX		

SECTION 8 DECALS

FIGURE 8-1. DECALS INSTALLATION - BROWN DECALS (CONTINUED)

FIG & ITEM #	PART NUMBER	DESCRIPTION	QTY.	REV.
202		Nameplate - Footswitch Options:	1	
	3252347	Australian Spec		
	1703518^	Dutch Spec		
	1693292	French Spec		
	1693294	German & Austrian Specs		
	1701600	Italian Spec		
	1701791	Spanish Spec		
	3252347	UK Spec		
203		Nameplate - Valve Select Options:	1	
	3251870	Australian Spec		
	1701531^	Dutch Spec		
	1701506	French Spec		
	1701562	German & Austrian Specs		
	1701696	Italian Spec		
	1701795	Spanish Spec		
	3251870	UK Spec		
204		Decal - Ground Control Location Options:	1	
	1700037	Australian Spec		
	1701616^	Dutch Spec		
	1701515	French Spec		
	1693285	German & Austrian Specs		
	1701599	Italian Spec		
	1701789	Spanish Spec		
	1700037	UK Spec		
205		Decal - Load Management Options:	1	
	1701296	Australian Spec Prior to S/N 3372		
	1703529	Australian Spec S/N 33726 to Present		
	1701532	Dutch Spec Prior to S/N 33726		
	1703606^	Dutch Spec S/N 33726 to Present		
	1701507	French Spec Prior to S/N 33726		
	1703607	French Spec S/N 33726 to Present		
	1701563	German & Austrian Spec Prior to S/N 33726		
	1703608	German & Austrian Spec S/N 33726 to Present		
	1701697	Italian Spec Prior to S/N 33726		
	1703609	Italian Spec S/N 33726 to Present		
	1701799	Spanish Spec Prior to S/N 33726		
	1703611	Spanish Spec S/N 33726 to Present		
	1701296	UK Spec Prior to S/N 3372		
	1703529	UK Spec S/N 33726 to Present		
206		Decal - Caution Options:	1	
	1690697	Australian Spec		
	1701567^	Dutch Spec		
	1701649	French Spec		
	1690697	German & Austrian Specs		
	1690697	Italian Spec		
	1690697	Spanish Spec		
	1690697	UK Spec		

SECTION 8 DECALS

FIGURE 8-1. DECALS INSTALLATION - BROWN DECALS (CONTINUED)

FIG & ITEM #	PART NUMBER	DESCRIPTION	QTY.	REV.
207	1690696	Decal - Caution Options: Australian Spec	A/R 1	
	Not Required	Dutch Spec	0	
	1693286	French Spec	1	
	1693288	German & Austrian Specs	1	
	1701601	Italian Spec	1	
	1701794	Spanish Spec	1	
	1690696	UK Spec	1	
	208		Decal - Caution Options:	1
1691483		Australian Spec		
1701596^-		Dutch Spec		
9983243		French Spec Prior to August 1991		
1693289		French Spec August 1991 to Present		
1693291		German & Austrian Specs		
1701602		Italian Spec		
208		1701798	Spanish Spec	
	1691483	UK Spec		

		Decal Kit Options:	1	
	Not Available	Australian Spec		
	2900984	Dutch Spec 110HX (Items with ^ Included in kit)		
	2900985	Dutch Spec 110HXER (Items with - Included in kit)		
	Not Available	French Spec		
Not Available	German & Austrian Specs			
Not Available	Italian Spec			
Not Available	Spanish Spec			
Not Available	UK Spec			

SECTION 8 DECALS

FIGURE 8-2. DECALS INSTALLATION - BLACK DECALS

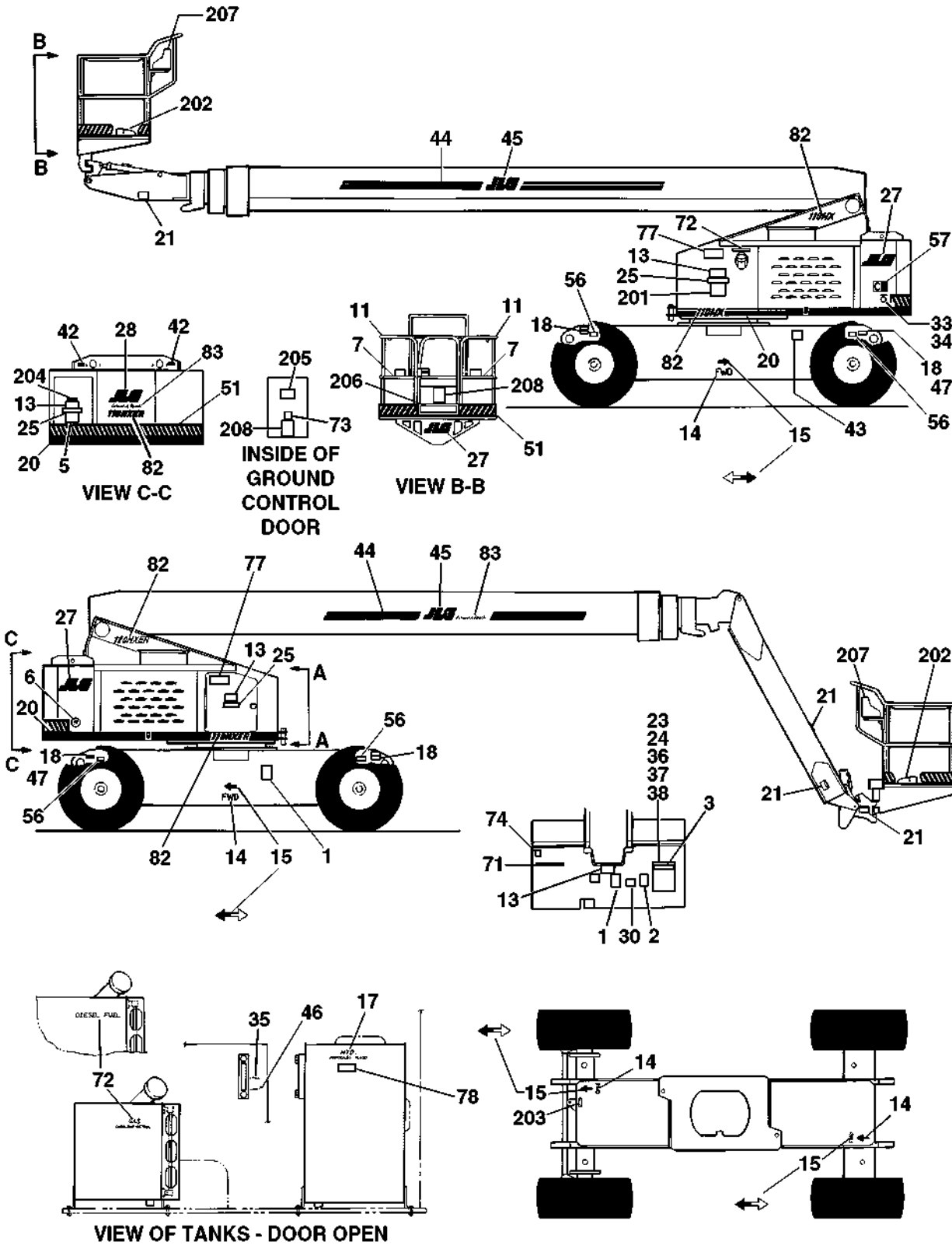

SECTION 8 DECALS

FIGURE 8-2. DECALS INSTALLATION - BLACK DECALS

FIG & ITEM #	PART NUMBER	DESCRIPTION	QTY.	REV.
		DECALS INSTALLATION (STANDARD PARTS)	Ref.	
1	Not Available	Nameplate - Serial Number (Location Will Vary)	1	
2	1700584	Decal - Patent	1	
3		Decal - Manual Options:	1	
	1700157	Decal (Prior to August 1991)		
	1701509	Decal (August 1991 to Present)		
4	Not Used			
5	1700643	Decal - Caution (Prior to August 1991) (110HXER & 100HX+10 Only)	1	
6	3251813	Decal - USA (Location Will Vary) (November 1989 to August 1995 Only)	1	
7	1700477	Decal - Attach Belt (Prior to August 1991)	2	
8 to 10	Not Used			
11	1700476	Decal - No Hands (Prior to August 1991)	2	
12	Not Used			
13		Decal - Crushing Options:	4	
	1700585	Decal (Prior to August 1991)		
	1701518	Decal (August 1991 to Present)		
14	1700053	Decal - FWD (Black) (Prior to August 1991 Only)	4	
15		Decal - Arrow Options:	4	
	1700058	Decal - Arrow (Black) (Prior to August 1991)		
	1701501	Decal - Arrow (Black/White) (August 1991 to Present)		
16	Not Used			
17		Decal - Hydraulic Options:	1	
	1700195	Decal - Hydraulic (Black) (Prior to August 1991)		
	1701504	Decal - Hydraulic (August 1991 to Present)		
18		Decal - Tie-Down/Lift Up Options:	A/R	
	1701326	Decal - Tie-Down (Black) (Prior to August 1991)	4	
	1700232	Decal - Lift Here (Black) (August 1991 to Present)	2	
	1701500	Decal - Lift Here (August 1991 to Present)	4	
	1702300	Decal - Tie-Down (August 1991 to Present)	4	
19	Not Used			
20		Decal - Black Stripe Options:	A/R	
	1701334	Decal (Prior to September 1995)	32ft/9.75m	
	1701703	Decal (September 1995 to Present)	27ft/8.23m	
21		Decal - Crushing Options:	A/R	
	1700640	Decal (Prior to August 1991)		
	1701518	Decal (August 1991 to Present)		
22	3820001	Rivet (Not Shown)	A/R	
23	0641408	Bolt 1/4"-20NC x 1"	1	
24	1060279	Cable, Lanyard	1	
25	1700580	Decal - Electrocution Hazard (Prior to August 1991 Only)	3	
26	Not Used			
27	1701321	Decal - JLG (Black) (Prior to September 1995 Only)	3	
28		Decal - JLG Options:	1	
	1701321	Decal - JLG (Black) (Prior to September 1995)		
	1702729	Decal - JLG (Black) (September 1995 to Present)		

SECTION 8 DECALS

FIGURE 8-2. DECALS INSTALLATION - BLACK DECALS (CONTINUED)

FIG & ITEM #	PART NUMBER	DESCRIPTION	QTY.	REV.
29	Not Used			
30	1700593	Decal - Inspection (Prior to August 1991 Only)	1	
31	Not Used			
32	Not Used			
33	0961127	Bushing, Snap	1	
34	0100010	Loctite, Adhesive	A/R	
35		Decal - Full/Add	1	
	1701336	Decal - Full/Add (Black) (Prior to August 1991)		
	1701502	Decal - Full/Add ((August 1991 to Present)		
36	0860520	Box, Manual Storage	1	
37	3311405	Locknut 1/4"-20NC	5	
38	4751400	Flatwasher 1/4"	6	
39	Not Used			
40	Not Used			
41	Not Used			
42		Decal Options:	2	
	1700975	Decal - Lift Here (Creme) (Prior to June 1991)		
	1700377	Decal - Lift Here (Brown) (June 1991 to August 1991)		
	1701500	Decal - Tie-Down/Lift Up (August 1991 to Present)		
43	Not Available	Decal - Bar Code (September 1995 to Present)	1	
44		Decal - Black Stripe Options:	A/R	
	1701334	Decal (100HX & 110HX) (Prior to September 1995)	24ft/7.3m	
	1701334	Decal (100HX+10 & 110HXER) (Prior to September 1995)	16ft/4.9m	
	1702731	Decal (September 1995 to Present)	27ft/8.23m	
45		Decal Options:	1	
	1701321	Decal - JLG (Black) (Prior to September 1995)		
	1702730	Decal - JLG Lift (Black) (September 1995 to Present)		
46	1701503	Decal - Hydraulic Oil Low (August 1991 to Present Only)	1	
47	1701499	Decal - Don't Lift/Tie Down (August 1991 to Present Only)	1	
48 to 50	Not Used			
51	4420052	Decal - Safety Stripe	19ft/5.8m	
52 to 55	Not Used			
56	1703484	Decal - Max Wheel Load	4	
57	1702928	Decal - CE	1	
		DECALS INSTALLATION (OPTIONAL PARTS)	Ref.	
71	1701543	Decal - Fuel LP Gas	1	
72		Decal - Fuel Options:	1	
	1701542	Decal - Gas		
	1701505	Decal - Diesel (Brown)		
73		Decal - Caution LP Gas Options:	1	
	3251028	Decal (Prior to May 1994)		
	3252356	Decal (May 1994 to Present)		
74	1700818	Decal - LP Gas Liquid Withdraw System	1	
75	Not Used			
76	Not Used			

SECTION 8 DECALS

FIGURE 8-2. DECALS INSTALLATION - BLACK DECALS (CONTINUED)

FIG & ITEM #	PART NUMBER	DESCRIPTION	QTY.	REV.
77	0255580	Lifting Diagram Installation	Ref.	—
	3252449	Decal - Lifting Diagram	2	
	3820001	Rivet	8	
78	1702788	Decal - Biodegradable Hydraulic Fluid	1	
		DECALS INSTALLATION (VARIABLE PARTS)	Ref.	
	0252125	110HX	Ref.	40
	0252657	100HX+10 & 110HXER	Ref.	C
81	Not Used			
82		Decal - Model Options (Location Will Vary):	A/R	
	1701335	110HX Decal (Black)		
	1701688	100HX+10 Decal (Black)		
83		Decal - Extend-A-Reach Options:	A/R	
	Not Required	110HX	0	
	1701431	100HX+10 & 110HXER	2	
		DECAL INSTALLATION (VARIABLE PARTS)	Ref.	
	0252142	Australian Spec Prior To S/N 28224	Ref.	B
	0257252	Australian Spec S/N28224 To Present	Ref.	2
	0252879	Dutch Spec	Ref.	3
	0252124	French Spec	Ref.	3
	0252123	German & Austrian Specs	Ref.	2
	0252687	Italian Spec	Ref.	2
	0253314	Spanish Spec	Ref.	2
	0252142	UK Spec110HX & 100HX+10	Ref.	3
	0258629	UK Spec100HX	Ref.	2
201		Nameplate - Axle Extend/Retract Options:	1	
	3251637	Australian Spec		
	1701533^	Dutch Spec		
	1701534	French Spec		
	1701564	German & Austrian Specs		
	1701698	Italian Spec		
	1701797	Spanish Spec		
	3251637	UK Spec 110HX & 100HX+10		
	1702301	UK Spec 100HX		
	202		Nameplate - Footswitch Options:	1
3252347		Australian Spec		
1703518^		Dutch Spec		
1693292		French Spec		
1693294		German & Austrian Specs		
1701600		Italian Spec		
1701791		Spanish Spec		
3252347		UK Spec		

SECTION 8 DECALS

FIGURE 8-2. DECALS INSTALLATION - BLACK DECALS (CONTINUED)

FIG & ITEM #	PART NUMBER	DESCRIPTION	QTY.	REV.	
203		Nameplate - Valve Select Options:	1		
	3251870	Australian Spec			
	1701531^	Dutch Spec			
	1701506	French Spec			
	1701562	German & Austrian Specs			
	1701696	Italian Spec			
	1701795	Spanish Spec			
	3251870	UK Spec			
204		Decal - Ground Control Location Options:	1		
	1700037	Australian Spec			
	1701616^	Dutch Spec			
	1701515	French Spec			
	1693285	German & Austrian Specs			
	1701599	Italian Spec			
	1701789	Spanish Spec			
	1700037	UK Spec			
205		Decal - Load Management Options:	1		
	1701296	Australian Spec Prior to S/N 3372			
	1703529	Australian Spec S/N 33726 to Present			
	1701532	Dutch Spec Prior to S/N 33726			
	1703606^	Dutch Spec S/N 33726 to Present			
	1701507	French Spec Prior to S/N 33726			
	1703607	French Spec S/N 33726 to Present			
	1701563	German & Austrian Spec Prior to S/N 33726			
	1703608	German & Austrian Spec S/N 33726 to Present			
	1701697	Italian Spec Prior to S/N 33726			
	1703609	Italian Spec S/N 33726 to Present			
	1701799	Spanish Spec Prior to S/N 33726			
	1703611	Spanish Spec S/N 33726 to Present			
	1701296	UK Spec Prior to S/N 3372			
	1703529	UK Spec S/N 33726 to Present			
206		Decal - Caution Options:	1		
	1690697	Australian Spec			
	1701567^	Dutch Spec			
	1701649	French Spec			
	1690697	German & Austrian Specs			
	1690697	Italian Spec			
	1690697	Spanish Spec			
	1690697	UK Spec			
207		Decal - Caution Options:	A/R		
	1690696	Australian Spec			1
	Not Required	Dutch Spec			0
	1693286	French Spec			1
	1693288	German & Austrian Specs			1
	1701601	Italian Spec			1
	1701794	Spanish Spec			1
	1690696	UK Spec			1

SECTION 8 DECALS

FIGURE 8-2. DECALS INSTALLATION - BLACK DECALS (CONTINUED)

FIG & ITEM #	PART NUMBER	DESCRIPTION	QTY.	REV.
208	1691483 1701596^~ 9983243 1693289 1693291 1701602 1701798 1691483	Decal - Caution Options: Australian Spec Dutch Spec French Spec Prior to August 1991 French Spec August 1991 to Present German & Austrian Specs Italian Spec Spanish Spec UK Spec	1	
	----- Not Available 2900984 2900985 Not Available Not Available Not Available Not Available Not Available	Decal Kit Options: Australian Spec Dutch Spec 110HX (Items with ^ Included in kit) Dutch Spec 110HXER (Items with - Included in kit) French Spec German & Austrian Specs Italian Spec Spanish Spec UK Spec	1	

SECTION 8 DECALS

FIGURE 8-2. DECALS INSTALLATION - BLACK DECALS (CONTINUED)

FIG & ITEM #	PART NUMBER	DESCRIPTION	QTY.	REV.

SECTION 9 RECOMMENDED SERVICE PARTS STOCK

MODELS 100HX/110HX+10/110HX EURO SPEC

The following list will service fleets of machines (built to current production per date on the front cover) with emergency repair parts which can be installed in the field. Parts from the list should be replaced when inventory is depleted to keep service parts stock supplied. For further information, contact your JLG dealer or the JLG Industries Parts Department.

JLG PART NUMBER	DESCRIPTION	QTY PER FLEET		
		1-10	10-20	20 OR MORE
STANDARD PARTS				
4360280	Switch, Tilt Indicator (Figure 2-4)	1	1	1
7012339	Coil - Vickers Valve (Figure 2-6)	1	1	1
7002450	Coil - Bang-Bang Valve (Dump) (Figure 2-8)	1	1	1
7000418	Coil - Bang-Bang Valve (Working) (Figures 2-8 and 2-11)	1	1	1
7004214	Element, Air Filter (Figures 2-21 and 2-27)	1 Dozen	1 Dozen	1 Dozen
3740067	Relay (Figures 2-21 and 2-27)	1	1	1
3740080	Relay (Figures 2-21 and 2-27)	1	1	1
3740059	Relay (Deutz) (Figure 2-18)	1	1	1
7000649	Filter, Engine Fuel (Deutz) (Figure 2-18)	1	1	1
7014503	Filter, Engine Oil (Deutz) (Figure 2-18)	1 case	1 case	1 case
2400054	Fuse (Figure 2-18)	1	1	1
4360155	Switch, Disconnect (Figure 2-18)	1	1	1
7008828	Cable, Throttle (Deutz) (Figure 2-19)	1	1	1
7008829	Board, PC (Deutz) (Figure 2-19)	1	1	1
1660183	Coupling (Deutz) (Figure 2-21)	1	1	1
1340046	Breather, Hydraulic Tank (Figure 2-23)	1	2	3
2120107	Element, Hydraulic Oil Filter (Figure 2-23)	4	8	12
3740070	Relay - SPDT (Figure 2-24)	1	1	1
3740016	Relay - 3PDT (Figure 2-24)	1	1	1
3740049	Relay - SPDT (Figures 2-24, 4-5 and 7-1)	1	1	1
4360216	Breaker, Circuit - 30 Amp (Figure 2-24)	1	1	1
4360232	Breaker, Circuit - 15 Amp (Figure 2-24)	1	1	1
4360284	Switch, Toggle (Figure 2-24)	1	1	1
4360003	Switch, Key (Figure 2-24)	1	1	1
2860002	Key (Figure 2-24)	1	1	1
4360212	Breaker, Circuit - 3 Amp (Deutz) (Figure 2-24)	1	1	1
4360274	Switch, Push Button (Figures 2-24 & 4-6)	1	1	1
4360202	Switch, Toggle (Figures 2-24 & 4-6)	1	1	1
4360200	Switch, Toggle (Figures 2-24 & 4-6)	1	1	1
3740123	Relay, Latch (Figure 2-24)	1	1	1
4360069	Breaker, Circuit - 10 Amp (Deutz) (Figures 2-24 & 4-6)	1	1	1
4360263	Switch, Toggle (Figure 2-25)	1	1	1
4360259	Switch, Proximity (Figure 2-25)	1	1	1
7006180	Power Track - Pin Kit (Figure 3-1)	24	24	24
7000637	Potentiometer (Figure 3-5)	1	1	1
7000638	Switch (Figure 3-5)	1	1	1
7000647	Cable (Figure 3-5)	1	1	1
4360153	Pendulum (Figure 3-5)	1	1	1
2940006	Latch, Platform Door (Figures 4-1, 4-2 and 4-3)	1	1	1
4360031	Footswitch (Figures 4-1, 4-2 and 4-3)	1	1	1

SECTION 9 RECOMMENDED SERVICE PARTS STOCK

MODELS 100HX/110HX+10/110HX EURO SPEC

The following list will service fleets of machines (built to current production per date on the front cover) with emergency repair parts which can be installed in the field. Parts from the list should be replaced when inventory is depleted to keep service parts stock supplied. For further information, contact your JLG dealer or the JLG Industries Parts Department.

JLG PART NUMBER	DESCRIPTION	QTY PER FLEET		
		1-10	10-20	20 OR MORE
1600247	Controller, PQ (Figure 4-6)	1	1	1
4360199	Switch, Toggle (Figure 4-6)	1	1	1
4360289	Switch, Push Pull (Figure 4-6)	1	1	1
4360112	Breaker, Circuit - 5 Amp (Figure 4-6)	1	1	1
4360161	Breaker, Circuit - 20 Amp (Figure 4-6)	1	1	1
7003961	Microswitch - 1600247 Controller (Figure 4-7)	1	1	1
3990010	Diode - 6 Amp (Figure 7-1)	2	2	2
VARIABLE PARTS				
4360277	Switch, Limit (Figures 1-6, 2-2, 3-5 and 3-6)	1	1	1
4360171	Switch, Limit (Figure 2-3)	1	1	1
7000645	Coil - Dual Axle Jack (Figure 1-6)	1	1	1
7012539	Coil - Dual Axle Jack (Figure 1-6)	1	1	1
7004368	Coil - 2 Speed Valve (Hydraforce Version) (Figure 1-6)	1	1	1
7006075	Coil - 2 Speed Valve (FPS Version) (Figure 1-6)	1	1	1
4360314	Switch, Toggle (Dual Axle Jack) (Figures 1-6)	1	1	1
7004368	Coil - Dump Valve (Hydraforce Version) (Figure 2-3)	1	1	1
7009745	Coil - Dump Valve (Vickers/Modular Controls Version) (Figure 2-3)	1	1	1
7000645	Coil - Dump Valve (Hydraforce Version) (Figure 2-3)	1	1	1
7003640	Coil - Dump Valve (Vickers/Modular Controls Version) (Figure 2-3)	1	1	1
7004368	Coil - Dump Valve (Hydraforce Version) (Figure 2-9)	1	1	1
7010555	Coil - Dump Valve (Vickers/Modular Controls Version) (Figure 2-9)	1	1	1
4360263	Switch, Limit (Figure 2-25)	1	1	1
7006193	Power Track - 1 ft. Section (100HX & 100HX+10 Standard - Left Side (Figure 3-1)	2	2	2
7006514	Power Track - 1 ft. Section (110HX Standard - Left Side (Figure 3-1)	2	2	2
7006196	Power Track - 1 ft. Section (100HX, 110HX & 100HX+10 with Chip - Left Side (Figure 3-1)	2	2	2
7006153	Power Track - 1 ft. Section (100HX, 110HX & 100HX+10 Standard - Right Side (Figure 3-1)	2	2	2
7006145	Power Track - 1 ft. Section (100HX, 110HX & 100HX+10 with Chip - Right Side (Figure 3-1)	2	2	2

SECTION 10 SPECIAL OPTIONS

Note: This list is to accommodate machines ordered with special equipment. Options may not be applicable to all models. For more specific parts information contact JLG Parts Department.

FIG & ITEM #	PART NUMBER	DESCRIPTION	QTY.	REV.
		MISCELLANEOUS SPECIAL OPTIONS	Ref.	
	0237063	Air Cleaner Service Indicator Installation	Ref.	
		Airline to Platform Installations	Ref.	
	0239261	1/2" Airline Installation	Ref.	
	0239262	3/4" Airline Installation	Ref.	
	0270723	Beacon Installation (Mounted on the platform)	Ref.	
	0239755	Bumper, CWT	Ref.	
	0256789	Camera Mounting Installation	Ref.	
	0253634	Cover Installation - Metal Console	Ref.	
		Exhaust Installations - Specials	Ref.	
		Deutz Engines:		
	0250633	Exhaust Purifier Installation (Prior to April 1993)	Ref.	
	0254109	Exhaust Purifier Installation (April 1993 to Present)	Ref.	
	0254472	Generator Installation - 230-240V/50Hz (Deutz Engines)	Ref.	
		Heaters Installation	Ref.	
	0252928	Deutz Engines	Ref.	
	0239998	Hostile Environment Package Installation	Ref.	
	0239257	Boom Wipers Installation	Ref.	
	0239258	Cylinder Bellows Installation	Ref.	
	4360295	Ignition Switch with Individual Coded Keys	Ref.	
		Lights Installation - Special	Ref.	
	0250176/1281175	Beacon Light Installation - Amber (On Hood) (Prior to January 1995)	Ref.	
	0255277/1282370	Beacon Light Installation - Amber (On Hood) (January 1995 to Present)	Ref.	
	0250177/1281175	Beacon Light Installation - Red (On Hood) (Prior to January 1995)	Ref.	
	0255278/1282370	Beacon Light Installation - Red (On Hood) (January 1995 to Present)	Ref.	
	0254409	Brake Lights Installation (Prior to January 1995)	Ref.	
	0255273/1282370	Brake Lights Installation (January 1995 to Present)	Ref.	
	0250179/1281175	Headlights and Taillights Installation (Prior to January 1995)	Ref.	

SECTION 10 SPECIAL OPTIONS

SECTION 10 SPECIAL OPTIONS

FIG & ITEM #	PART NUMBER	DESCRIPTION	QTY.	REV.
	0255271/1282370	Headlights and Taillights Installation (January 1995 to Present)	Ref.	
	0255816/1282370	Strobe Light Installation - Amber (On Hood)	Ref.	
	0254474/1281175	Turn Signals Installation (Prior to January 1995)	Ref.	
	0255272/1282370	Turn Signals Installation (January 1995 to S/N 39439)	Ref.	
	0258039	Load Sensing System (French Spec)	Ref.	
	0252917	Oil Cooler Installation	Ref.	
	0239260/1281002	Oxy-Acetylene Lines Installation	Ref.	
	0253558	Receptacle Mounting Plate Installation (Australian Spec)	Ref.	
	3536566	Plate	1	
		Tank Installations - Fuel and Oil (Special)	Ref.	
	0255937	52 Gallon Tank Fuel Installation	Ref.	
	4400389	Tank - 52 Gallon	1	
		Tools for Service:		
	7002821	Crimper, Wire	Ref.	
	2900838	Fastener Kit - U.S. Standards	Ref.	
	7002823	Pin Extractor - Universal (For Electrical Connectors with Pins and Sockets)	Ref.	
	7016654	Screwdriver, Magnetic	Ref.	
	7002822	Screwdriver, Pontimeter	Ref.	
	7004275	Seal Tool 1" (For Cylinders)	Ref.	
	7004276	Seal Tool 1 1/2" (For Cylinders)	Ref.	
	7002828	Stripper, Wire	Ref.	
	7014676	Tool Kit - U.S. Standards	Ref.	
	9900443	Tool Box and Tools	Ref.	
	0257728	Tube Rack Installation	Ref.	
	0253050	Turntable Pinion Shield Installation	Ref.	



3120801



An Oshkosh Corporation Company

Corporate Office
JLG Industries, Inc.
1 JLG Drive
McConnellsburg PA. 17233-9533
USA

☎ (717) 485-5161

📠 (717) 485-6417

JLG Worldwide Locations

JLG Industries (Australia)
P.O. Box 5119
11 Bolwarra Road
Port Macquarie
N.S.W. 2444
Australia

☎ +61 2 65 811111

📠 +61 2 65 810122

JLG Latino Americana Ltda.
Rua Eng. Carlos Stevenson,
80-Suite 71
13092-310 Campinas-SP
Brazil

☎ +55 19 3295 0407

📠 +55 19 3295 1025

JLG Industries (UK) Ltd
Bentley House
Bentley Avenue
Middleton
Greater Manchester
M24 2GP - England

☎ +44 (0)161 654 1000

📠 +44 (0)161 654 1001

JLG France SAS
Z.I. de Baulieu
47400 Fauillet
France

☎ +33 (0)5 53 88 31 70

📠 +33 (0)5 53 88 31 79

JLG Deutschland GmbH
Max-Planck-Str. 21
D - 27721 Ritterhude - Ihlpohl
Germany

☎ +49 (0)421 69 350 20

📠 +49 (0)421 69 350 45

JLG Equipment Services Ltd.
Rm 1107 Landmark North
39 Lung Sum Avenue
Sheung Shui N. T.
Hong Kong

☎ (852) 2639 5783

📠 (852) 2639 5797

JLG Industries (Italia) s.r.l.
Via Po. 22
20010 Pregnana Milanese - MI
Italy

☎ +39 029 359 5210

📠 +39 029 359 5845

Oshkosh-JLG Singapore
Technology Equipment Pte
Ltd
29 Tuas Ave 4,
Jurong Industrial Estate
Singapore, 639379

☎ +65-6591 9030

📠 +65-6591 9031

Plataformas Elevadoras
JLG Iberica, S.L.
Trapadella, 2
P.I. Castellbisbal Sur
08755 Castellbisbal, Barcelona
Spain

☎ +34 93 772 4700

📠 +34 93 771 1762

JLG Sverige AB
Enkopingsvagen 150
Box 704
SE - 176 27 Jarfalla
Sweden

☎ +46 (0)850 659 500

📠 +46 (0)850 659 534