



# *Illustrated Parts Manual*

**Models**  
**CM25RT**  
**CM33RT**  
**CM40RT**

**3120821**  
*December 1, 1992*





# TABLE OF CONTENTS

FIGURE NO.	DESCRIPTION	PAGE NO.
<b>SECTION 1 — FRAME</b>		
1-1	Frame, Steering and Axle Installation .....	1-2
1-2	Tire and Wheel Drive Installations .....	1-8
1-3	Drive Motor Assembly - Gas and Diesel Machines .....	1-12
1-4	Drive Motor Assembly - Electric Machines .....	1-14
1-5	Drive Brake Assembly .....	1-18
1-6	Drive Hub Assemblies .....	1-20
1-7	Drive Hub/Brake Assemblies .....	1-24
1-8	Frame Mounted Components .....	1-28
<b>SECTION 2 — GROUND COMPONENTS</b>		
2-1	Control Valves and Tanks Installation - Gas/Diesel Machines .....	2-2
2-2	Control Valves Assembly - Racine Bang-Bang (Gas/Diesel Machines) .....	2-6
2-3	Control Valve Assembly - Racine 2 Stack (Electric Machines) ...	2-10
2-4	Control Valve Assembly - Racine 2 Stack (Electric Machines) ...	2-12
2-5	Modular Control Valve Assembly (Electric Machines) .....	2-14
2-6	Control Valve Assembly - FPS 4 Stack .....	2-16
2-7	Engine Installation - Ford VSG-411 .....	2-20
2-8	Dual Fuel Installation .....	2-26
2-9	110V Generator Installation - Ford .....	2-28
2-10	Engine Installation - Deutz .....	2-30
2-11	110V Generator Installation .....	2-36
2-12	Pump Assembly - Sunstrand .....	2-38
2-13	Electrical Components Installation (Electric Machines Only) .....	2-42
2-14	Battery Charger Assembly (Electric Machines Only) .....	2-46
2-15	Ground Control Box Assembly and Installation .....	2-48
2-16	Hoods and Beacon Light Installation .....	2-52
<b>SECTION 3 — SIZZOR ARMS</b>		
3-1	Sizzors Arms Installation - CM40RT .....	3-2
3-2	Sizzors Arms Installation - CM33RT .....	3-6
3-3	Sizzors Arms Installation - CM25RT .....	3-10
3-4	Sizzors Arms Guard Installation .....	3-14
<b>SECTION 4 — PLATFORM</b>		
4-1	Standard Platform and Optional Components Installation .....	4-2
4-2	Extendable Platform Installation (Optional) .....	4-6
4-3	Traversing Platform Installation (Optional) .....	4-8
4-4	Platform Control Box Installation .....	4-10

## TABLE OF CONTENTS (CONTINUED)

FIGURE NO.	DESCRIPTION	PAGE NO.
<b>SECTION 5 — CYLINDERS</b>		
5-1	Axle Lockout Cylinder Assembly .....	5-2
5-2	Leveling Jack Cylinder Assembly .....	5-4
5-3	Lift Cylinder Assemblies .....	5-6
5-4	Steer Cylinder Assembly .....	5-10
5-5	Traversing Platform Extension Cylinder Assembly .....	5-12
<b>SECTION 6 — HYDRAULICS</b>		
6-1	Hydraulic Diagram - Manual Descent/Emergency Lowering .....	6-2
6-2	Hydraulic Diagram - Oscillating Axle (Optional) .....	6-4
6-3	Hydraulic Diagram - Overload/Tilt (French Spec) .....	6-6
6-4	Hydraulic Diagram - Standard (Electric Machines) .....	6-8
6-5	Hydraulic Diagram - Standard (2WD) .....	6-12
6-6	Hydraulic Diagram - Standard (4WD) .....	6-16
6-7	Hydraulic Diagram List - Complete .....	6-21
<b>SECTION 7 — ELECTRICAL</b>		
7-1	Wiring Diagram - Dual Fuel (Ford) .....	7-2
7-2	Wiring Diagram - 110V Generator (Ford) .....	7-3
7-3	Wiring Diagram - 110V Generator (Deutz) .....	7-4
7-4	Wiring Diagram - Overload/Tilt Interlock (French Spec) .....	7-5
7-5	Wiring Diagram - Platform (Diesel Machines) .....	7-6
7-6	Wiring Diagram - Platform (Gas Machines) .....	7-7
7-7	Wiring Diagram - Platform (Electric Machines) .....	7-9
7-8	Wiring Diagram - Standard (Ford Gas Machines) .....	7-10
7-9	Wiring Diagram - Standard (Deutz Diesel Machines) .....	7-11
7-10	Wiring Diagram - Standard (Electric Machines) .....	7-12
7-11	Electrical Components and Wiring Diagram List .....	7-13
<b>SECTION 8 — DECALS</b>		
8-1	Decals Installation .....	8-2
<b>SECTION 9 — RECOMMENDED SERVICE PARTS STOCK</b>		
9-1	Recommended Service Parts Stock .....	9-1

# SECTION 1 FRAME

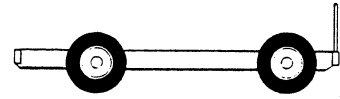

## TABLE OF CONTENTS

FIGURE NO.	DESCRIPTION	
1-1	Frame, Steering and Axle Installation .....	1-2
1-2	Tire and Wheel Drive Installations .....	1-8
1-3	Drive Motor Assembly - Gas and Diesel Machines .....	1-12
1-4	Drive Motor Assembly - Electric Machines .....	1-14
1-5	Drive Brake Assembly .....	1-18
1-6	Drive Hub Assemblies .....	1-20
1-7	Drive Hub/Brake Assemblies .....	1-24
1-8	Frame Mounted Components .....	1-28

# SECTION 1 FRAME

## SECTION 1 FRAME

FIGURE 1-1. FRAME, STEERING AND AXLE INSTALLATIONS.

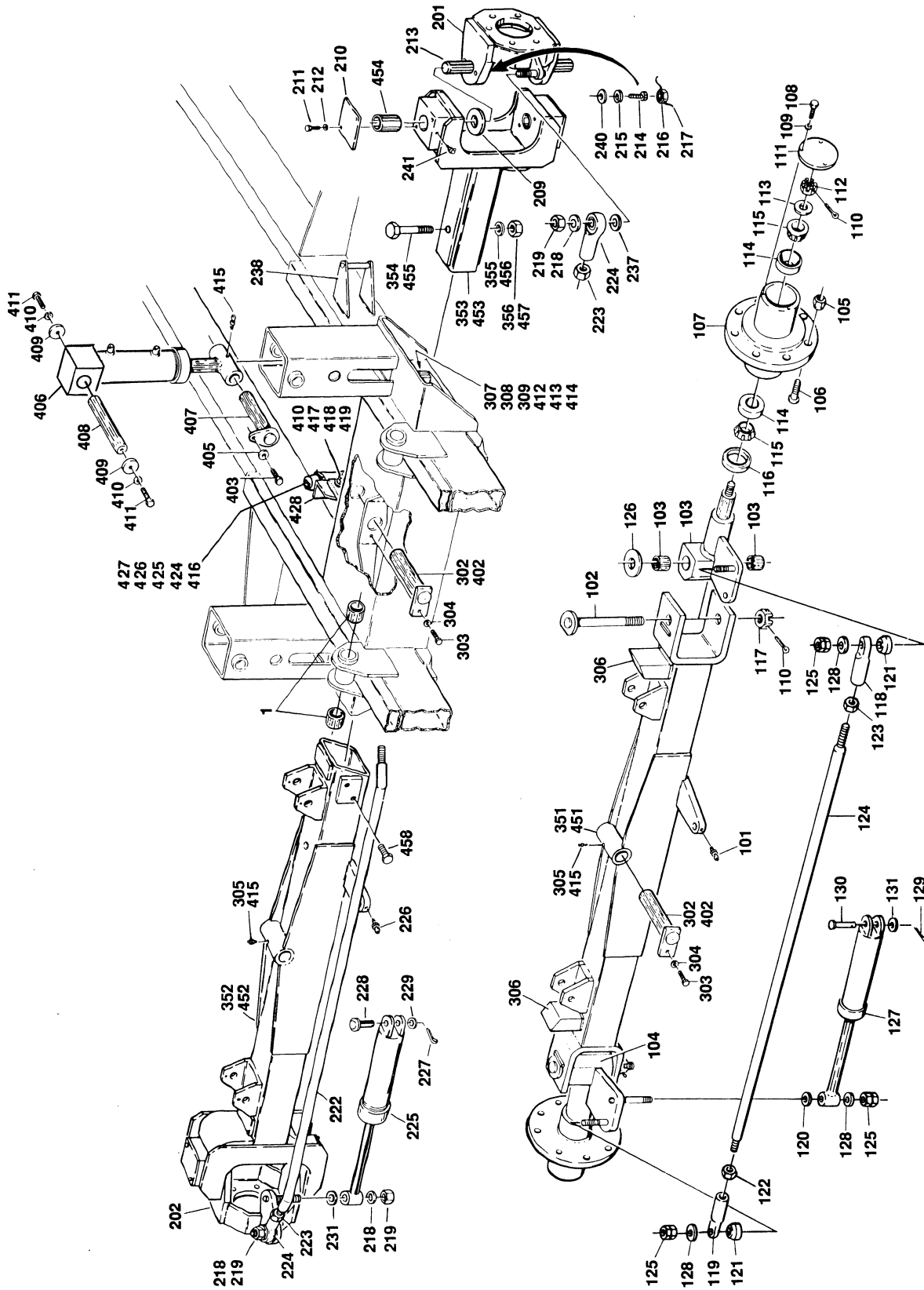
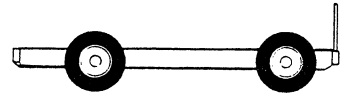

# SECTION 1

# FRAME

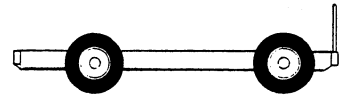

# SECTION 1 FRAME

FIGURE & ITEM NO	PART NUMBER	DESCRIPTION	QTY.	REV.
1—1		<b>FRAME, STEERING AND AXLE INSTALLATIONS</b>	Ref.	
	2360318	<b>FRAME WELDMENT - GAS AND DIESEL</b>	Ref.	F
	2360336	<b>FRAME WELDMENT - ELECTRIC</b>	Ref.	A
—1	0961409	Bushing, Super Oilite	4	
	1281678	<b>STEERING INSTALLATION - 2WD (STANDARD PARTS)</b>	Ref.	B
—101	2160002	Fitting, Grease	3	
—102	3421340	King Pin	2	
—103	4843578	Spindle Weldment (Left Side)	1	
	0960839	Bushing, Bronze	2	
—104	4843577	Spindle Weldment (Right Side)	1	
	0960839	Bushing, Bronze	2	
—105	3300012	Nut, Wheel	18	
—106	0630137	Stud, Wheel	18	
—107	2780177	Hub, Wheel	2	
—108	0721004	Screw, Machine #10-24NC x 1/2"	6	
—109	4761000	Lockwasher #10	6	
—110	3450610	Pin, Cotter 3/16" x 2 1/2"	4	
—111	1120311	Cap, Hub	2	
—112	3322603	Nut, Slotted 1" - 12NF	2	
—113	4740034	Washer, Hardened	2	
—114	0440174	Cup, Bearing	4	
—115	0440175	Cone, Bearing	4	
—116	3960353	Seal, Oil	2	
—117	3323003	Nut, Slotted 1 1/4"-12NF	2	
—118	1360188	Clevis, Ball Joint (Left Side)	1	
—119	1360122	Clevis, Ball Joint (Right Side)	1	
—120	4740321	Washer, Special	1	
—121	4740372	Washer, Special	2	
—122	3322202	Nut, Jam 3/4"-16NF (Right Hand Threads)	1	
—123	3300230	Nut, Jam 3/4"-16NF (Left Hand Threads)	1	
—124	3841051	Tie-Rod	1	
—125	3312205	Locknut 3/4"-16NF	3	
—126	0440162	Bearing, Thrust	2	
—127	1681604	Steer Cylinder Assembly (See Section 5 for Breakdown)	1	
—128	4712200	Flatwasher 3/4" Narrow	3	
—129	3450608	Pin, Cotter 3/16" x 2"	1	
—130	3431620	Pin, Clevis 1" x 2 1/2"	1	
—131	4712600	Flatwasher 1" Narrow	1	

SECTION 1  
FRAME

**SECTION 1**

**FRAME**

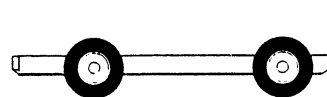

FIGURE & ITEM NO	PART NUMBER	DESCRIPTION	QTY.	REV.
1-1		<b>FRAME, STEERING AND AXLE INSTALLATIONS (CONTINUED)</b>		
	0252241	<b>STEERING INSTALLATION - 4 WD (STANDARD PARTS)</b>		
-201	4130232	Spindle Weldment - Left Side	1	
-202	4130233	Spindle Weldment - Right Side	1	
-203	Not Used			
-204	Not Used			
-205	Not Used			
-206	Not Used			
-207	Not Used			
-208	Not Used			
-209	0440161	Washer, Thrust	2	
-210	3530244	Plate, Cover	4	
-211	0641404	Bolt 1/4"-20NC x 1/2"	8	
-212	4761400	Lockwasher 1/4"	8	
-213	3421887	Kingpin	4	
-214	0641608	Bolt 3/8"-16NC x 1"	8	
-215	4761600	Lockwasher 3/8"	8	
-216	1380124	Clip, Retainer	8	
-217	4920096	Wire, Safety (4 Pieces 1 foot (1.3m) Long)	4 ft/1.2m	
-218	4712200	Flatwasher 3/4" Narrow	3	
-219	3312205	Locknut 3/4"-10NC	3	
-220	Not Used			
-221	Not Used			
-222	3841056	Tie-Rod	1	
-223	3322202	Nut, Jam 3/4"-16NF	2	
-224	1360122	Clevis, Ball Joint	2	
-225	1681604	Steer Cylinder Assembly (See Section 5 for Breakdown)	1	
-226	2160002	Fitting, Grease	2	
-227	3450608	Pin, Cotter 3/16" x 2"	1	
-228	3431620	Pin, Clevis 1" x 2 1/2"	1	
-229	4712600	Flatwasher 1" Narrow	1	
-230	Not Used			
-231	4740321	Washer, Special	1	
-232	Not Used			
-233	Not Used			
-234	Not Used			
-235	Not Used			
-236	Not Used			
-237	4740372	Washer, Special	2	
-238	4843735	Guide, Hose	2	
-239	Not Used			
-240	4751600	Flatwasher 3/8" Wide	8	
-241	2160001	Fitting, Grease	4	
	1281364	<b>FIXED AXLE INSTALLATION (STANDARD PARTS)</b>	Ref.	—
-301	Not Used			
-302	4842795	Pin, Axle	1	
-303	0641606	Bolt 3/8"-16NC x 3/4"	1	



## SECTION 1

## FRAME

SECTION 1  
FRAME

FIGURE & ITEM NO	PART NUMBER	DESCRIPTION	QTY.	REV.
1-1		<b>FRAME, STEERING AND AXLE INSTALLATIONS (CONTINUED)</b>		
—304	4761600	Lockwasher 3/8"	1	
—305	2160002	Fitting, Grease	1	
—306	0560901	Block, Stop	2	
—307	3531655	Plate, Shim 1/8"/3.2mm	A/R	
—308	3531656	Plate, Shim 11/64"/4.4mm	A/R	
—309	3531657	Plate, Shim 1/4"/6.4mm	A/R	
	0251094	<b>FIXED AXLE INSTALLATION - 2WD (VARIABLE PARTS)</b>	Ref.	—
	0251095	<b>FIXED AXLE INSTALLATION - 4WD (VARIABLE PARTS)</b>	Ref.	—
—351	4843571	Axle Weldment - 2WD	1	
—352	4843592	Axle Weldment - 4WD	1	
	0961029	Bushing, Bronze (At Kingpin)	2	
—353	4843596	Yoke, Axle - 4WD Only	1	
—354	0642240	Bolt 3/4"-10NC x 5" - 4WD Only	1	
—355	4752200	Flatwasher 3/4" - 4WD Only	1	
—356	3312205	Locknut 3/4"-10NC - 4WD Only	1	
	1281488	<b>OSCILLATING AXLE INSTALLATION - OPTION (STANDARD PARTS WHEN EQUIPPED)</b>	Ref.	B
—401	Not Used			
—402	4842795	Pin, Axle	1	
—403	0641406	Bolt 1/4"-20NC x 3/4"	2	
—404	Not Used			
—405	4751400	Flatwasher 1/4"	4	
—406	1682427	Lockout Cylinder Assembly (See Section 5 for Breakdown)	2	
—407	4842794	Pin (Bottom Attach)	2	
—408	3421335	Pin (Top Attach)	2	
—409	4740308	Flatwasher, Special	4	
—410	4761600	Lockwasher 3/8"	7	
—411	0641606	Bolt 3/8"-16NC x 3/4"	5	
—412	3531655	Plate, Shim 1/8"/3.2mm	A/R	
—413	3531656	Plate, Shim 11/64"/4.4mm	A/R	
—414	3531657	Plate, Shim 1/4"/6.4mm	A/R	
—415	2160002	Fitting, Grease	3	
—416	4640668	Lockout Valve Assembly	1	
	7012516	Repair Kit	1	
—417	0641609	Bolt 3/8"-16NC x 1/8"	2	
—418	3311601	Nut 3/8"-16NC	2	
—419	4751600	Flatwasher 3/8" Wide	2	
—420	Not Used			
—421	Not Used			



# SECTION 1

# FRAME

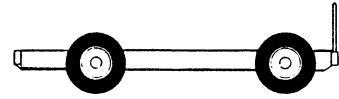
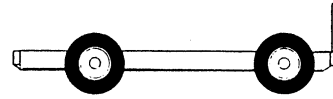

# SECTION 1 FRAME

FIGURE & ITEM NO	PART NUMBER	DESCRIPTION	QTY.	REV.
1-1		<b>FRAME, STEERING AND AXLE INSTALLATIONS (CONTINUED)</b>		
-422	Not Used			
-423	Not Used			
-424	0721008	Bolt #10-24NC x 3/4"	4	
-425	4761000	Lockwasher #10	4	
-426	3311001	Nut #10-24NC	4	
-427	0641405	Bolt 1/4"-20NC x 5/8"	2	
-428	3534805	Plate, Mounting	1	
	0252541	<b>OSCILLATING AXLE INSTALLATION - 2WD OPTION (VARIABLE PARTS WHEN EQUIPPED)</b>	Ref.	—
	0252540	<b>OSCILLATING AXLE INSTALLATION - 4WD OPTION (VARIABLE PARTS WHEN EQUIPPED)</b>	Ref.	—
-451	4843571	Axle Weldment - 2WD	1	
-452	4843592	Axle Weldment - 4WD (Includes Item 454)	1	
-453	4843596	Yoke Weldment - 4WD Only (Includes Item 454)	1	
-454	0961029	Bushing, Bronze - 4WD Only (2 Per Side)	4	
-455	0642240	Bolt 3/4"-10NC x 5" - 4WD Only	1	
-456	4752200	Flatwasher 3/4" - 4WD Only	1	
-457	3312205	Locknut 3/4" - 10NC - 4WD Only	1	
-458	0642208	Bolt 3/4" - 10NC x 1" - 4WD Only	2	
	0100011	----- Loctite #242	A/R	

**SECTION 1 FRAME**

**FIGURE 1-2. TIRE AND WHEEL DRIVE INSTALLATIONS.**

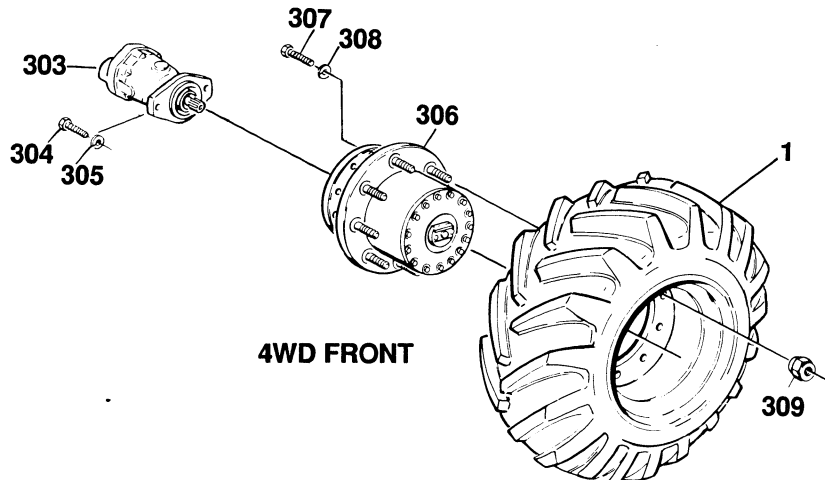
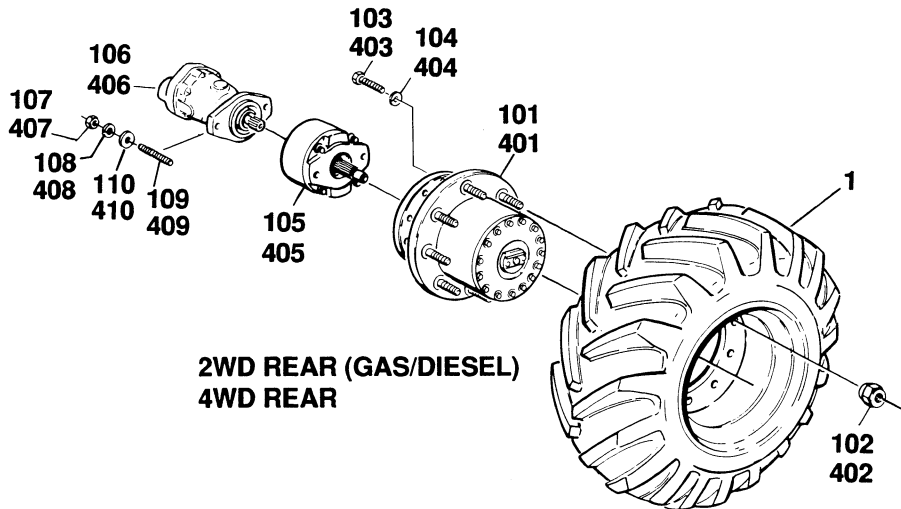
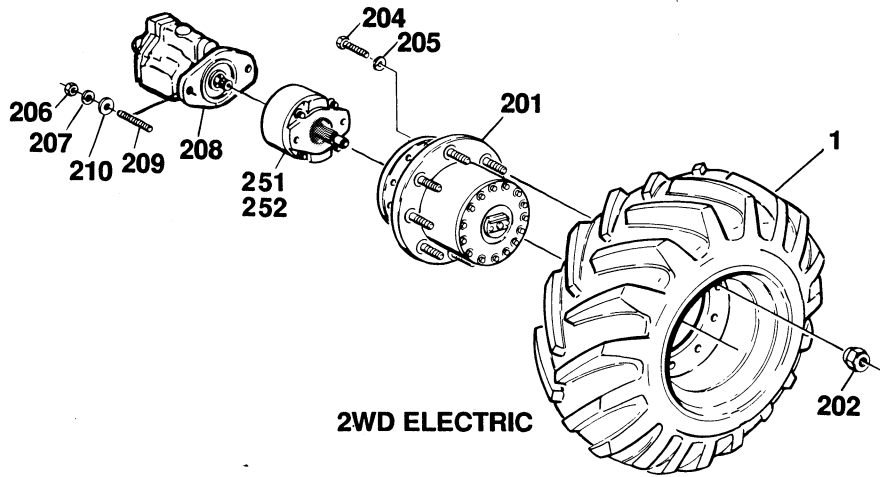
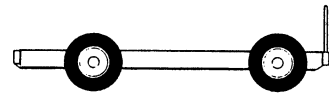

# SECTION 1

# FRAME

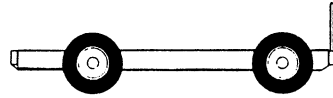

# SECTION 1 FRAME

FIGURE & ITEM NO	PART NUMBER	DESCRIPTION	QTY.	REV.
1—2		<b>TIRE AND WHEEL DRIVE INSTALLATIONS</b>	Ref.	
	0251438	<b>TIRE AND WHEEL INSTALLATION (FOAM-FILLED)</b>	Ref.	—
—1	0251436	Tire and Wheel Assembly - Left Side	2	
	0251437	Tire and Wheel Assembly - Right Side	2	
		<b>Note: Foam-filled Tire and Wheel Assemblies sold as an Assembly only.</b>		
	0252484	<b>WHEEL DRIVE INSTALLATION - 2WD GAS/DIESEL</b>	Ref.	A
—101	2780169	Drive Hub Assembly (See Figure 1-6 for Breakdown)	2	
—102	3300012	Nut, Wheel	18	
—103	0642014	Bolt 5/8"-11NC x 1 3/4"	12	
—104	4762000	Lockwasher 5/8"	12	
—105	0920084	Drive Brake Assembly (See Figure 1-5 for Breakdown)	2	
—106	3160158	Drive Motor Assembly (See Figure 1-3 for Breakdown)	2	
—107	3311801	Nut 1/2"-13NC	4	
—108	4761800	Lockwasher 1/2"	4	
—109	4300092	Stud 1/2"-13NC x 5 1/2"	4	
—110	4711800	Flatwasher 1/2" Narrow	4	
	0100011	Loctite #242	A/R	
	0252304	<b>WHEEL DRIVE INSTALLATION - 2WD ELECTRIC (STANDARD PARTS)</b>	Ref.	B
—201	2780168	Drive Hub Assembly (See Figure 1-6 for Breakdown)	2	
—202	3300012	Nut, Wheel	18	
—203	0920084	Drive Brake Assembly (See Figure 1-5 for Breakdown)	2	
—204	0642014	Bolt 5/8"-11NC x 1 3/4"	12	
—205	4762000	Lockwasher 5/8"	12	
—206	3311801	Nut 1/2"-13NC	4	
—207	4761800	Lockwasher 1/2"	4	
—208	3160118	Drive Motor Assembly (See Figure 1-4 for Breakdown)	2	
—209	4300092	Stud	4	
—210	4711800	Flatwasher 1/2" Narrow	4	
	0100011	Loctite #242	A/R	
	0252241	<b>WHEEL DRIVE INSTALLATION - 4WD FRONT ONLY (GAS/DIESEL MACHINES)</b>	Ref.	A
—301	Not Used			
—302	Not Used			



# SECTION 1

# FRAME

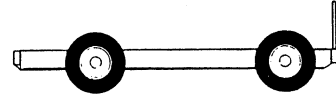

# SECTION 1 FRAME

FIGURE & ITEM NO	PART NUMBER	DESCRIPTION	QTY.	REV.
1-2		<b>TIRE AND WHEEL DRIVE INSTALLATIONS (CONTINUED)</b>	Ref.	
-303	3160170	Drive Motor Assembly (See Figure 1-3 for Breakdown)	2	
-304	0641811	Bolt 1/2"-13NC x 1 3/8"	4	
-305	4761800	Lockwasher 1/2"	4	
-306	2780191	Drive Hub/Brake Assembly (See Figure 1-7 for Breakdown)	2	
-307	0642014	Bolt 5/8"-11NC x 1 3/4"	12	
-308	4762000	Lockwasher 5/8"	12	
-309	3300012	Nut, Wheel	18	
	0252483	<b>WHEEL DRIVE INSTALLATION - 4WD REAR ONLY (GAS/DIESEL)</b>	Ref.	A
-401	2780167	Drive Hub Assembly (See Figure 1-6 for Breakdown)	2	
-402	3300012	Nut, Wheel	18	
-403	0642014	Bolt 5/8"-11NC x 1 3/4"	12	
-404	4762000	Lockwasher 5/8"	12	
-405	0920084	Drive Brake Assembly (See Figure 1-5 for Breakdown)	2	
-406	3160158	Drive Motor Assembly (See Figure 1-3 for Breakdown)	2	
-407	3311801	Nut 1/2"-13NC	4	
-408	4761800	Lockwasher 1/2"	4	
-409	4300092	Stud 1/2"-13NC x 5 1/2"	4	
-410	4711800	Flatwasher 1/2" Narrow	4	
	0100011	----- Loctite #242	A/R	

SECTION 1

FRAME

FIGURE 1-3. DRIVE MOTOR ASSEMBLY -  
GAS AND DIESEL MACHINES.

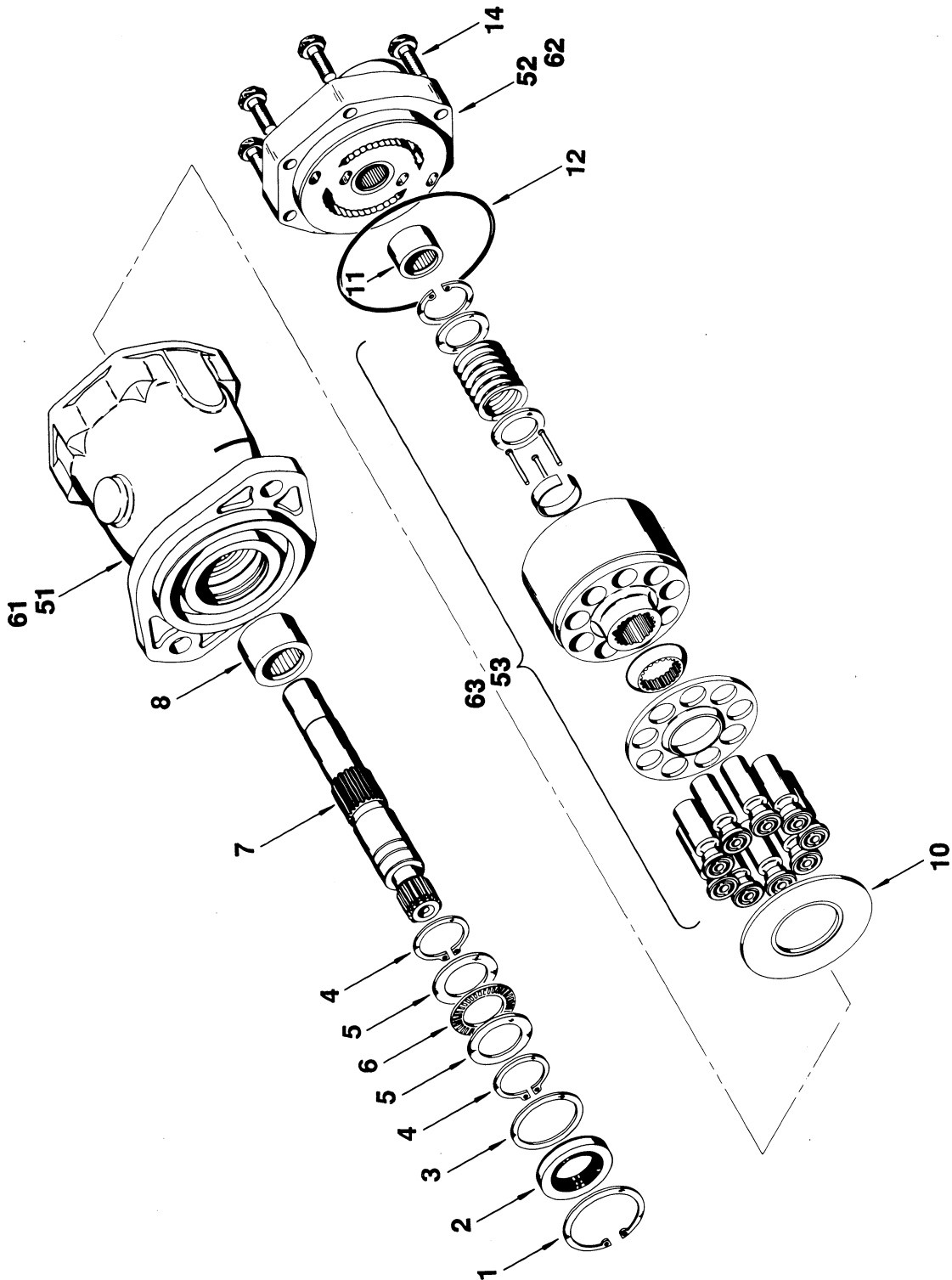
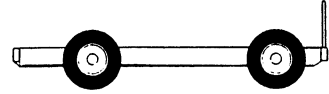



# SECTION 1

# FRAME

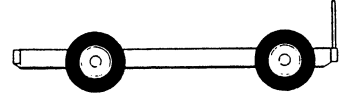

# SECTION 1 FRAME

FIGURE & ITEM NO	PART NUMBER	DESCRIPTION	QTY.	REV.
1-3		<b>DRIVE MOTOR ASSEMBLY - GAS AND DIESEL MACHINES</b>	Ref.	
		<b>DRIVE MOTOR ASSEMBLY (STANDARD PARTS)</b>	Ref.	
-1	Kit	Ring, Retaining	1	
-2	Kit	Seal, Shaft	1	
-3	7004906	Washer	1	
-4	Kit	Ring, Retaining	2	
-5	7004907	Race, Thrust	2	
-6	7004908	Bearing, Thrust	1	
-7	7007874	Shaft, Splined	1	
-8	7004910	Bearing	1	
-9	Not Used			
-10	7007876	Insert, Camplate	1	
-11	7004917	Bearing	1	
-12	Kit	O-Ring	1	
-13	Not Used			
-14	7007879	Bolt	6	
	3160158	<b>DRIVE MOTOR ASSEMBLY (ALL MACHINES EXCEPT 4WD FRONT)</b>	Ref.	—
-51	7007875	Housing Assembly (Includes Item 8)	1	
-52	7007878	Back Plate Assembly (Includes Item 11)	1	
-53	7007880	Rotating Kit Assembly (Sold as an Assembly Only)	1	
	3160170	<b>DRIVE MOTOR ASSEMBLY (4WD FRONT)</b>	Ref.	—
-61	7007881	Housing Assembly (Includes Item 8)	1	
-62	7007882	Back Plate Assembly (Includes Item 11)	1	
-63	7007883	Rotating Kit Assembly (Sold as an Assembly Only)	1	
	2900714	Seal Kit (Includes Items 1,2,4 and 12)	1	

SECTION 1 FRAME

FIGURE 1-4. DRIVE MOTOR ASSEMBLY -  
ELECTRIC MACHINES.

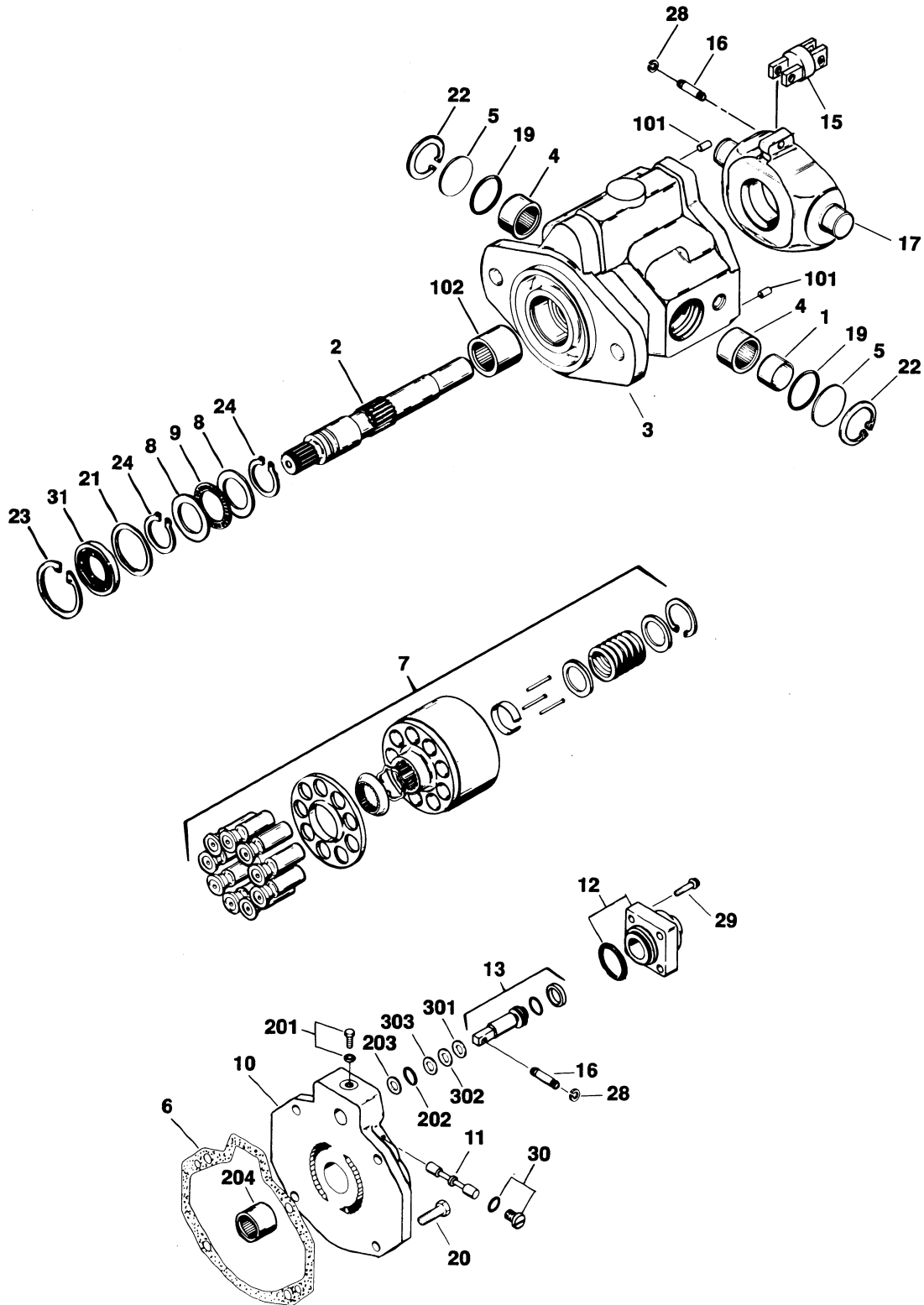
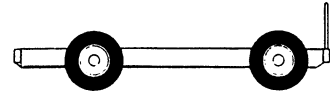

# SECTION 1

# FRAME

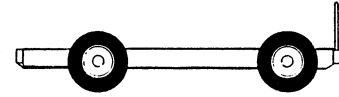

# SECTION 1 FRAME

FIGURE & ITEM NO	PART NUMBER	DESCRIPTION	QTY.	REV.
1-4	3160118	<b>DRIVE MOTOR ASSEMBLY - ELECTRIC MACHINES</b>	Ref.	A
-1	7004911	Race, Inner	1	
-2	7004912	Shaft, Drive	1	
-3	7004959	Housing Assembly (Includes items 101 and 102)	1	
-4	7004914	Bearing	2	
-5	7004913	Cover, Trunnion	2	
-6	Kit	Gasket, Housing	1	
-7	7004916	Rotating Kit Assembly (Sold as an Assembly Only)	1	
-8	7004907	Race, Thrust	2	
-9	7004908	Bearing, Thrust	1	
-10	7004941	Back Plate Assembly (Includes Items 201-204)	1	
-11	7004946	Spool, Shuttle	1	
-12	7004939	Control Piston Housing Assembly	1	
	Kit	O-Ring	1	
-13	7004948	Control Piston Assembly	1	
	Kit	Ring, Slippery	1	
	Kit	O-Ring	1	
-14	Not Used			
-15	7004928	Connector, Camplate	1	
-16	7004929	Pin, Connector	2	
-17	7007517	Camplate	1	
-18	Not Used			
-19	Kit	O-Ring	2	
-20	7004933	Bolt 3/8"-16NC x 1 1/4"	4	
-21	7004906	Washer	1	
-22	7004935	Ring, Retaining - 1 5/8"	2	
-23	7004904	Ring, Retaining - 2"	1	
-24	7004909	Ring, Retaining - 1 1/8"	2	
-25	Not Used			
-26	Not Used			
-27	Not Used			
-28	7004937	Ring, Retaining - 5/16"	4	
-29	7004938	Bolt, Socket 1/4"-28NF x 7/8"	4	
-30	7004944	Plug Assembly	2	
	Kit	O-Seal	2	
-31	Kit	Seal, Shaft	1	
	7004959	Housing Assembly	Ref.	
-101	7004960	Rollpin 1 1/4" x 1/2"	2	
-102	7004910	Bearing	1	
	7004941	Back Plate Assembly	Ref.	
-201	7004942	Plug Assembly	1	
	Kit	O-Ring	1	
-202	Kit	O-Ring	1	
-203	Kit	Ring, Back-Up	1	
-204	7004917	Bearing	1	



# SECTION 1

# FRAME

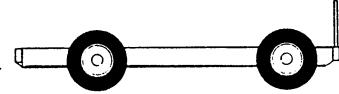
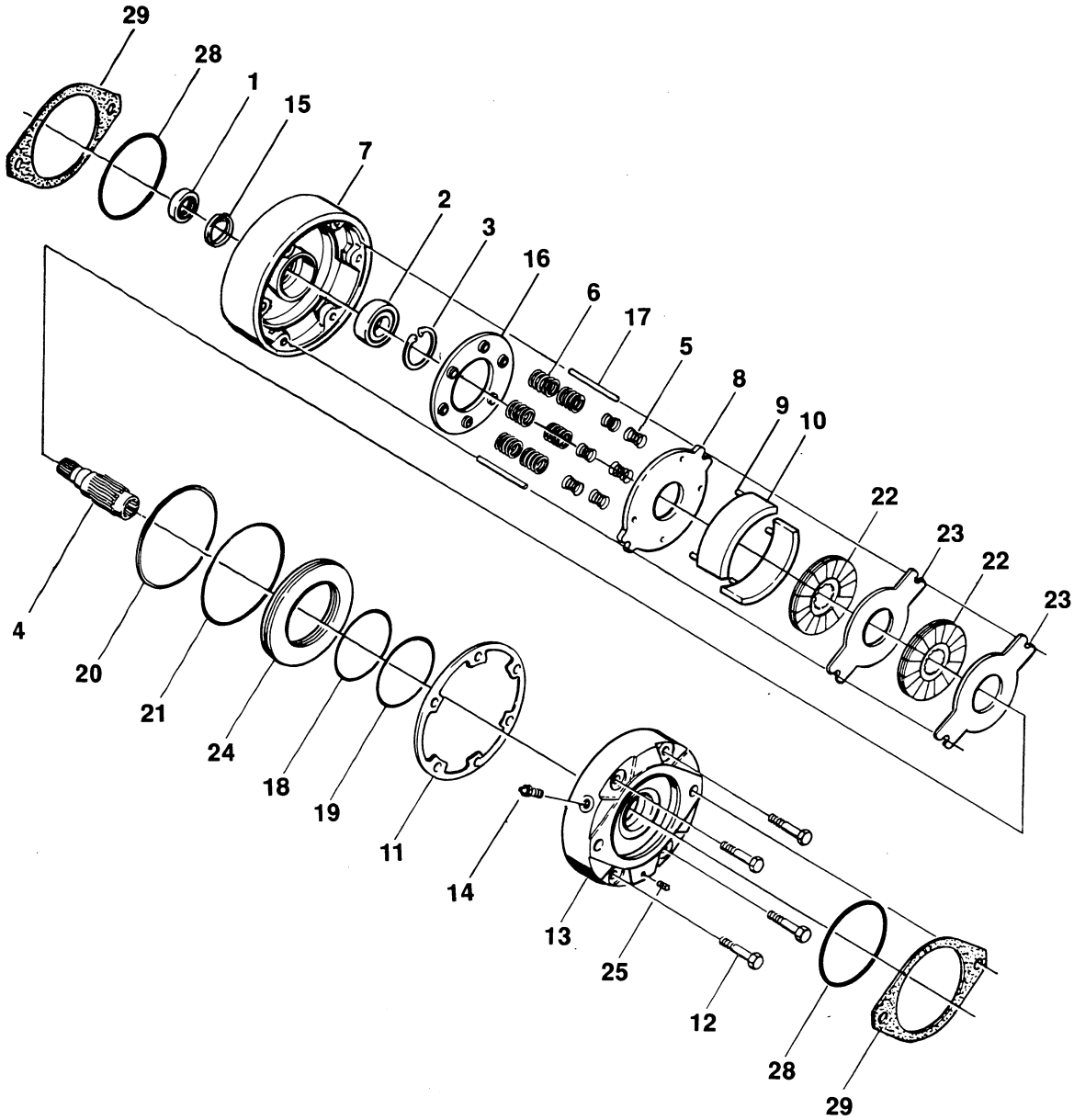

FIGURE & ITEM NO	PART NUMBER	DESCRIPTION	QTY.	REV.
1-4	3160118	<b>DRIVE MOTOR ASSEMBLY - ELECTRIC MACHINES (CONTINUED)</b>	Ref.	A
	3160118	<b>MOTOR SUB-ASSEMBLY</b>	Ref.	
-301	4100028	Spacer, Piston - .105"/2.7mm	A/R	
-302	4100027	Spacer, Piston - .092"/2.3mm	A/R	
-303	4100029	Spacer, Piston - .110"/2.8mm	A/R	
	2900449	----- Seal Kit - Complete (Includes Items Indicated by "Kit" in P/N column)	1	

SECTION 1  
FRAME

# SECTION 1 FRAME

FIGURE 1-5. DRIVE BRAKE ASSEMBLY.



## SECTION 1

## FRAME

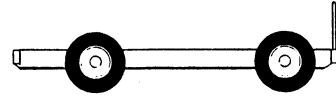
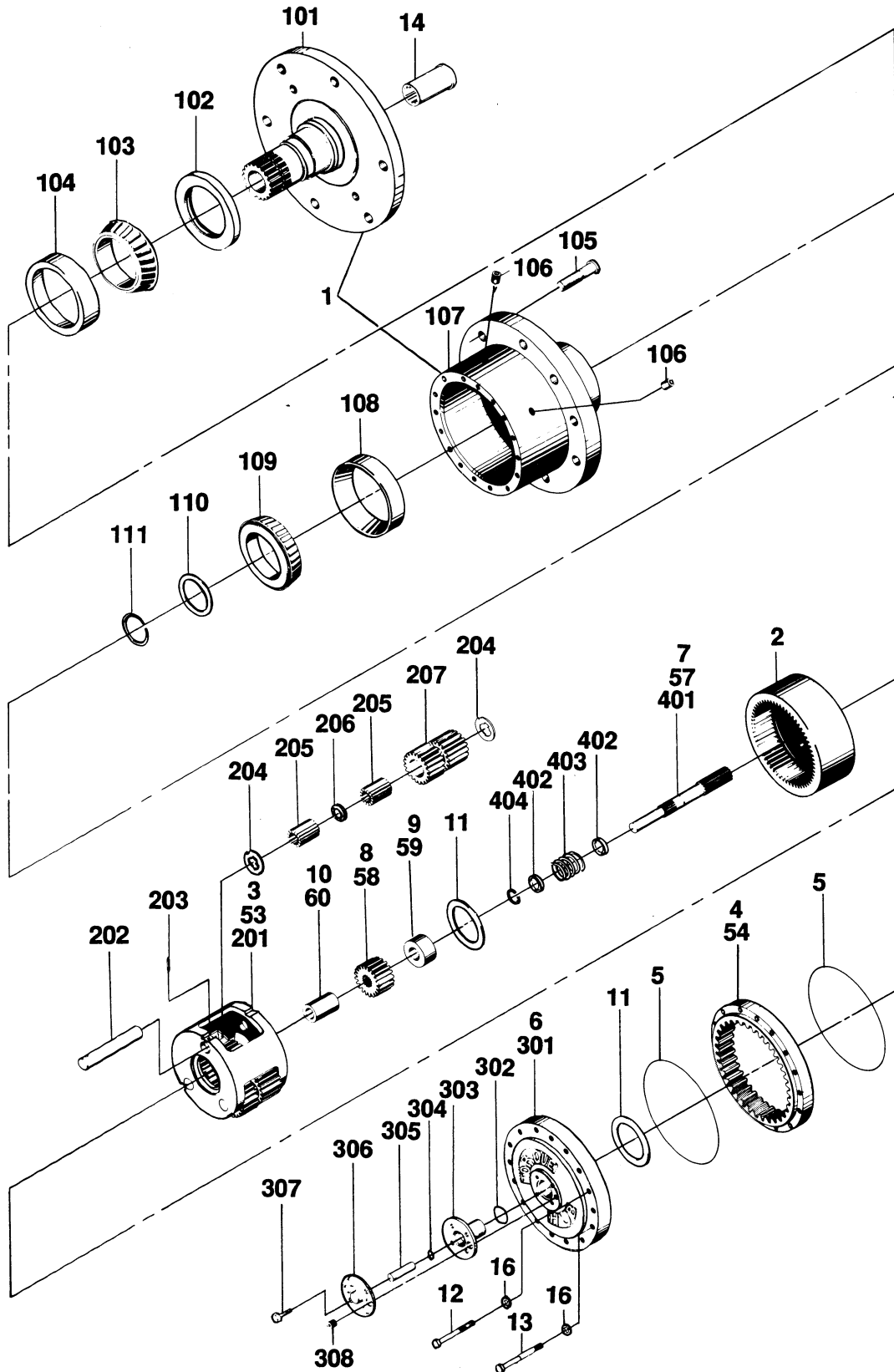
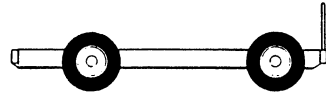

FIGURE & ITEM NO	PART NUMBER	DESCRIPTION	QTY.	REV.
1—5	0920084	<b>DRIVE BRAKE ASSEMBLY</b>	Ref.	—
—1	Kit	Seal, Oil	1	
—2	Kit	Bearing	1	
—3	7007977	Ring, Retaining	1	
—4	7011712	Shaft	1	
—5	7007979	Spring (Inner)	6	
—6	7007980	Spring (Outer)	6	
—7	7011713	Housing	1	
—8	Kit	Plate, Return	1	
	7011715	Separator Assembly	2	
—9	7011714	Pin	4	
—10	7007983	Separator	2	
—11	Kit	Seal, Case	1	
—12	7007985	Bolt, Washer Head	4	
—13	7007986	Cover	1	
—14	7007914	Screw, Bleeder	1	
—15	7011716	Ring, Retainer	1	
—16	7011717	Guide, Spring	1	
—17	7007987	Pin, Dowel	2	
—18	Kit	Ring, Back-up	1	
—19	Kit	O-Ring	1	
—20	Kit	Ring, Back-up	1	
—21	Kit	O-Ring	1	
—22	Kit	Rotor	2	
—23	Kit	Stator	2	
—24	7007923	Piston	1	
—25	7007924	Plug, Pipe	1	
—26	Not Used			
—27	Not Used			
—28	Kit	O-Ring	2	
—29	Kit	Gasket	2	
	2900766	Seal Kit (Includes Items 1,11,18,19,20,21,28 and 29)	1	
	2900767	Lining Kit (Includes Items 8, 11, 22,23, 28 and 29)	1	
	2900768	Bearing Kit (Includes Items 1,2,11,28 and 29)	1	

SECTION 1  
FRAME

SECTION 1 FRAME

FIGURE 1-6. DRIVE HUB ASSEMBLIES.





# SECTION 1

# FRAME

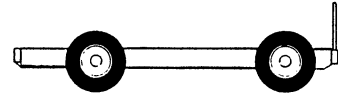

SECTION 1  
FRAME

FIGURE & ITEM NO	PART NUMBER	DESCRIPTION	QTY.	REV.
1-6		<b>DRIVE HUB ASSEMBLIES</b>	Ref.	
		<b>DRIVE HUB ASSEMBLIES (STANDARD PARTS)</b>	Ref.	
-1		Hub-Spindle Sub Assembly (See Items 101-111 for Breakdown)	1	
-2	7000246	Gear, Internal	1	
-3		Carrier Assembly (See Variable Parts)	1	
-4		Gear, Ring (See Variable Parts)	1	
-5	7000230	O-Ring	2	
-6	7001989	Cover Assembly (Includes Items 301-308)	1	
-7		Input Shaft Assembly (See Variable Parts)	1	
-8		Gear, Input (See Variable Parts)	1	
-9		Spacer, Thrust (See Variable Parts)	1	
-10		Spacer, Thrust (See Variable Parts)	1	
-11	7000253	Washer, Thrust	2	
-12	7000217	Bolt	12	
-13	7000214	Bolt, Shoulder	4	
-14	7000206	Coupling	1	
-15	Not Used			
-16	7007603	Flatwasher	16	
	2780169	<b>DRIVE HUB ASSEMBLY -2WD/2WS GAS/DIESEL (VARIABLE PARTS)</b>	Ref.	
	2780168	<b>DRIVE HUB ASSEMBLY - 2WD ELECTRIC (VARIABLE PARTS)</b>	Ref.	—
	2780167	<b>DRIVE HUB ASSEMBLY - 4WD/2WS REAR DRIVE ONLY (BUILT NOVEMBER 1991 TO NOVEMBER 1992 ONLY) (VARIABLE PARTS)</b>	Ref.	—
-51	Not Used			
-52	Not Used			
-53	7000247	Carrier Assembly (Gas/Diesel Machines) (See Items 201-207 for Breakdown)	1	
	7000202	Carrier Assembly (Electric Machines) (See Items 201-207 for Breakdown)	1	
-54	7000248	Gear, Ring (Gas/Diesel Machines)	1	
	7000203	Gear, Ring (Electric Machines)	1	
-55	Not Used			
-56	Not Used			
-57	7000250	Input Shaft Assembly (2WD Machines) (See Items 401-404 for Breakdown)	1	
	7007650	Input Shaft Assembly (4WD Machines) (See Items 401-404 for Breakdown)	1	
-58	7000251	Gear, Input (2WD Gas/Diesel)	1	
	7000201	Gear, Input (2WD Electric)	1	
	7007652	Gear, Input (4WD)	1	
-59	7000252	Spacer, Thrust (2WD Machines)	1	
	7007653	Spacer, Thrust (4WD Machines)	1	



# SECTION 1

# FRAME

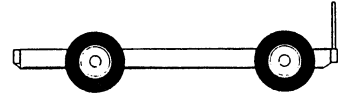

# SECTION 1 FRAME

FIGURE & ITEM NO	PART NUMBER	DESCRIPTION	QTY.	REV.
1-6		<b>DRIVE HUB ASSEMBLIES (CONTINUED)</b>	Ref.	
-60	7007654	Spacer, Thrust (4WD Machines Only)	1	
		<b>HUB - SPINDLE SUB-ASSEMBLY</b>	Ref.	
-101	7001997	Spindle	1	
-102	7001998	Seal	1	
-103	Kit	Cone, Bearing	1	
-104	Kit	Cup, Bearing	1	
-105	7007697	Bolt, Wheel	9	
-106	7000242	Plug, Pipe	2	
-107	7007601	Hub	1	
-108	7000257	Cup, Bearing	1	
-109	7000258	Cone, Bearing	1	
-110	7000232	Spacer	1	
-111	7000229	Ring, Retaining	1	
	7000247	<b>CARRIER ASSEMBLY (GAS/DIESEL MACHINES)</b>	Ref.	
	7000202	<b>CARRIER ASSEMBLY (ELECTRIC MACHINES)</b>	Ref.	
-201	7001931	Carrier	1	
-202	7001911	Shaft	3	
-203	7001913	Pin, Roll	3	
-204	7001985	Washer, Thrust	6	
-205	7001909	Roller, Needle	96	
-206	7000263	Spacer	3	
-207	7001912	Gear, Cluster (Gas/Diesel Machines)	3	
	7007643	Gear, Cluster (Electric Machines)	3	
	7001989	<b>COVER ASSEMBLY</b>	Ref.	
-301	7000226	Cover	1	
-302	7000215	O-Ring	1	
-303	7000227	Cap, Cover	1	
-304	7000213	O-Ring	1	
-305	7000212	Rod, Disconnect	1	
-306	7000211	Cap, Disconnect	1	
-307	7000220	Bolt	4	
-308	7000243	Plug, Pipe	1	
	7000250	<b>INPUT SHAFT ASSEMBLY (2WD MACHINES)</b>	Ref.	
	7007650	<b>INPUT SHAFT ASSEMBLY (4WD MACHINES)</b>	Ref.	
-401	7000260	Shaft (2WD Machines)	1	
	7007651	Shaft (4WD Machines)	1	
-402	7000263	Spacer	2	
-403	7000262	Spring	1	
-404	7000261	Ring, Retaining	1	
	7010429	----- Bearing Kit (Includes Items 103 and 104)	1	

SECTION 1 FRAME

FIGURE 1-7. DRIVE HUB/BRAKE ASSEMBLIES.

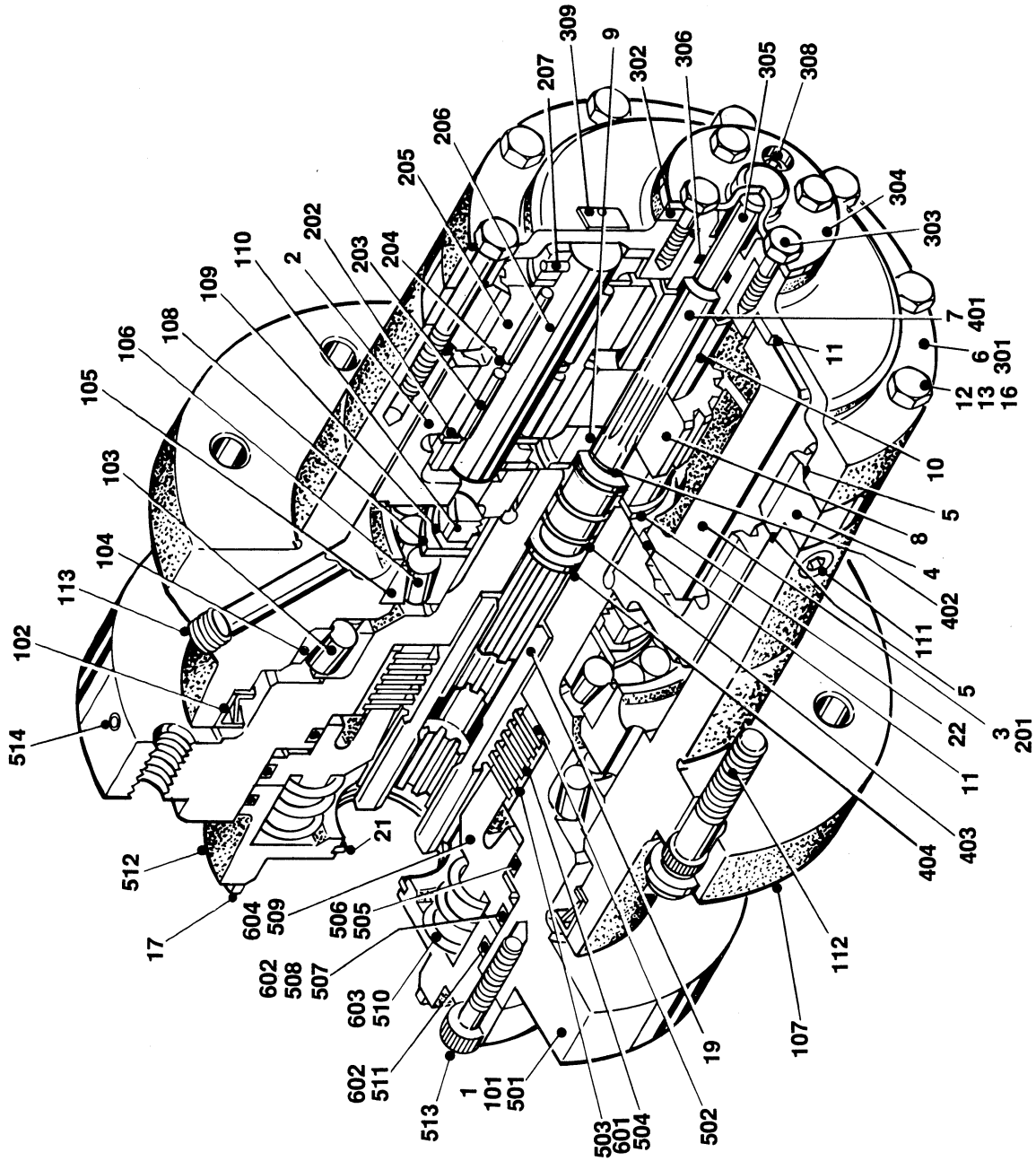
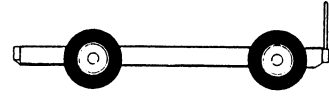

# SECTION 1

# FRAME

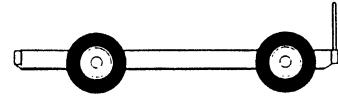

SECTION 1  
FRAME

FIGURE & ITEM NO	PART NUMBER	DESCRIPTION	QTY.	REV.
1-7		<b>DRIVE HUB/BRAKE ASSEMBLIES</b>	Ref.	
	2780191	<b>DRIVE HUB/BRAKE ASSEMBLIES (STANDARD PARTS)</b>	Ref.	
-1		Hub/spindle/Brake Assembly (See Items 101-113 for Breakdown)	1	
-2	7007691	Gear, Internal	1	
-3	7000247	Carrier Assembly (See Items 201-207 for Breakdown)	1	
-4	7000248	Gear, Internal	1	
-5	Kit	O-Ring	2	
-6		Cover Assembly (See Items 301-309 for Breakdown)	1	
-7	7007650	Input Shaft Assembly (See Items 401-404 for Breakdown)	1	
-8	7007652	Gear, Input	1	
-9	7007653	Spacer, Input	1	
-10	7007654	Spacer, Input	1	
-11	7000253	Washer, Thrust	2	
-12	7000217	Bolt	12	
-13	7000214	Bolt, Shoulder	4	
-14	Not Used			
-15	Not Used			
-16	7007603	Flatwasher	16	
-17	7007692	Gasket	1	
-18	Not Used			
-19	7010470	Coupling	1	
-20	Not Used			
-21	7010459	Ring, Retainer	1	
-22	7001922	Washer, Thrust	1	
		<b>HUB/SPINDLE/BRAKE SUB-ASSEMBLY</b>	Ref.	
-101	7010469	Brake Assembly - 4WD Machines with I.D. Plate (Item 309) Stamped June 1992 or Earlier (See Items 501-514 for Breakdown)	1	
	7010473	Brake Assembly - 4WD Machines with I.D. Plate (Item 309) Stamped July 1992 or Later (See Items 601-604 for Breakdown)	1	
-102	Kit	Seal, Lip	1	
-103	7007683	Cup, Bearing	1	
-104	7007684	Cone, Bearing	1	
-105	7007685	Cup, Bearing	1	
-106	7007686	Cone, Bearing	1	
-107	7007687	Housing	1	
-108	7007688	Flatwasher, Tanged	1	
-109	7007689	Flatwasher, Tanged	1	
-110	7007690	Nut, Bearing	1	
-111	7000242	Plug, Pipe 1/4" NPT	2	
-112	7000241	Stud, Wheel	9	
-113	7007617	Plug, Pipe 3/8" NPT (Magnetic)	2	

## SECTION 1

## FRAME

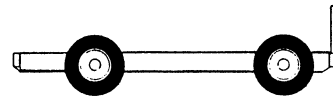
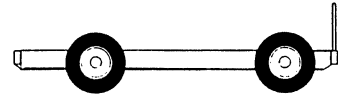

FIGURE & ITEM NO	PART NUMBER	DESCRIPTION	QTY.	REV.
1-7		<b>DRIVE HUB/BRAKE ASSEMBLIES (CONTINUED)</b>	Ref.	
	7000247	<b>CARRIER ASSEMBLY - 4WD MACHINES</b>	Ref.	
-201	7001931	Carrier	1	
-202	7001985	Washer, Thrust - Tanged	6	
-203	7001909	Bearing, Needle	96	
-204	7000263	Spacer, Thrust	3	
-205	7001911	Shaft, Planet	3	
-206	7001912	Gear, Cluster	3	
-207	7001913	Rollpin - 4WD Machines	3	
	7010474	Rollpin - 2WD/4WS Machines	3	
	7001989	<b>COVER ASSEMBLY</b>	Ref.	
-301	7000226	Cover	1	
-302	7000227	Cap, End	1	
-303	7000220	Bolt 1/4"-20NC x 3/4"	4	
-304	7000211	Cap, Disengage	1	
-305	7000212	Rod, Disengage	1	
-306	Kit	O-Ring	1	
-307	Kit	O-Ring	1	
-308	7000243	Plug, Pipe 1/8" NPT	1	
-309	Not Available	Plate, I.D.	1	
	7007650	<b>INPUT SHAFT ASSEMBLY - 4WD MACHINES</b>	Ref.	
-401	7007651	Shaft	1	
-402	7000261	Ring, Retaining	1	
-403	7000262	Spring	1	
-404	7000263	Spacer, Thrust	2	
	7010469	<b>BRAKE ASSEMBLY - 4WD MACHINES WITH I.D. PLATE (ITEM 309) STAMPED JUNE 1992 OR EARLIER</b>	Ref.	
-501	7014100	Spindle	1	
-502	7014101	Spacer	1	
-503	7014102	Disc, Stationary	7	
-504	7014103	Disc, Rotating	6	
-505	Kit	Ring, Back-up	1	
-506	Kit	O-Ring	1	
-507	Kit	Ring, Back-up Ring	1	
-508	Kit	O-Ring	1	
-509	7014108	Piston	1	
-510	7014109	Spring	6	
	7014110	Spring	2	
-511	Kit	O-Ring	1	

# SECTION 1

# FRAME



# SECTION 1 FRAME

FIGURE & ITEM NO	PART NUMBER	DESCRIPTION	QTY.	REV.
1-7		<b>DRIVE HUB/BRAKE ASSEMBLIES (CONTINUED)</b>	Ref.	
-512	7014112	Cover	1	
-513	Not Available	Bolt, Socket Head 3/8"-16NC x 1 1/4"	8	
-514	7014113	Expander	1	
	2900816	----- Brake O-Ring Kit (Includes Items 505-508 and 511)	1	
	7010473	<b>BRAKE ASSEMBLY 4WD MACHINES WITH I.D. PLATE (ITEM 309) STAMPED JULY 1992 OR LATER</b>	Ref.	
-601	7010475	Brake Lining Kit	1	
-602	7010476	Brake O-Ring Kit	1	
-603	7010477	Brake Spring Repair Kit	1	
-604	7010478	Brake Piston Repair Kit	1	
	2900754	----- Seal Kit - Hub (Includes items 5,17,102,306 and 307)	1	

SECTION 1 FRAME

FIGURE 1-8. FRAME MOUNTED COMPONENTS INSTALLATION.

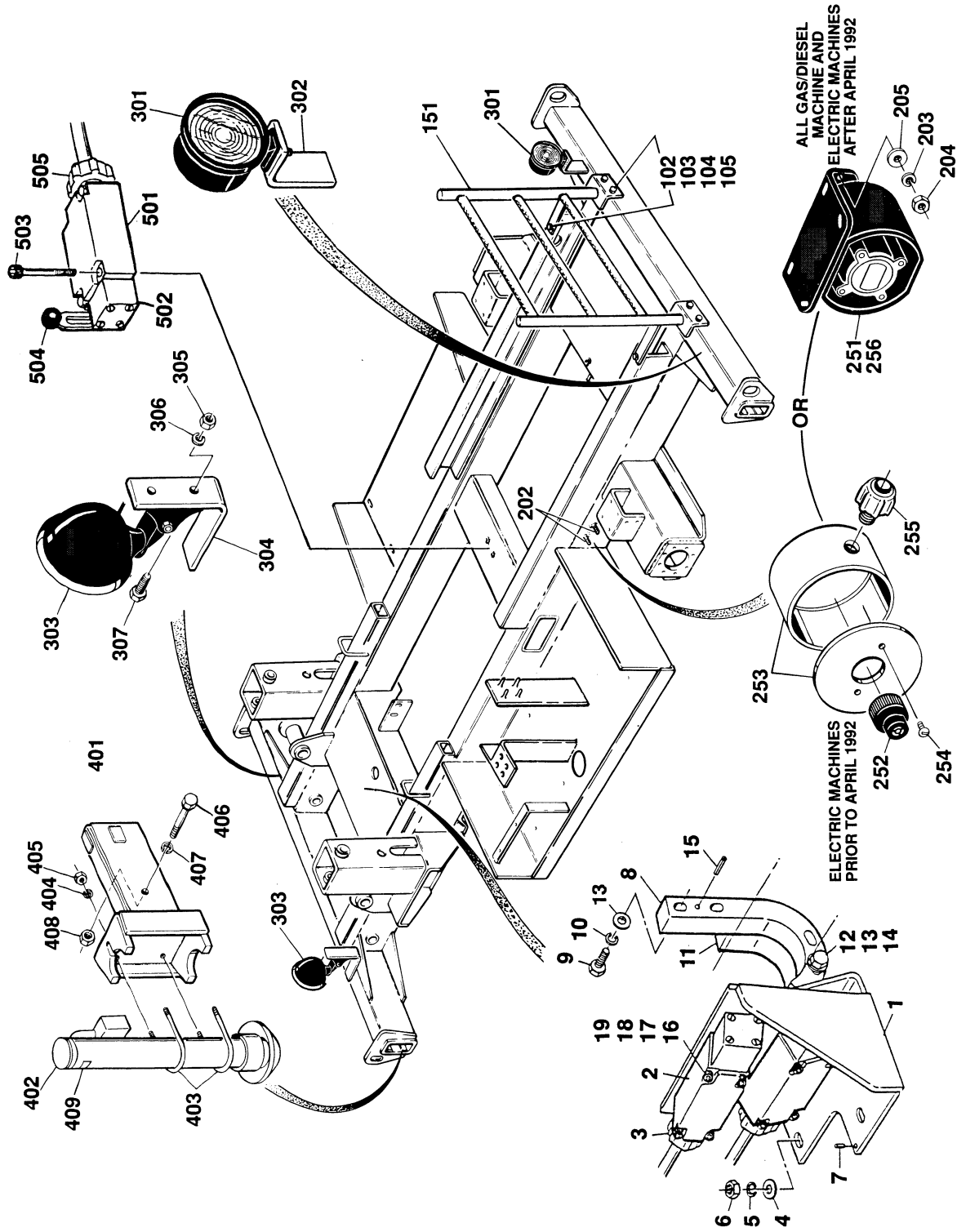
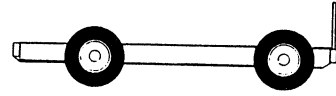



# SECTION 1

# FRAME

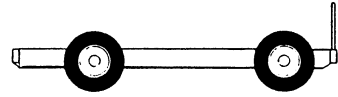

# SECTION 1 FRAME

FIGURE & ITEM NO	PART NUMBER	DESCRIPTION	QTY.	REV.
1-8		<b>FRAME MOUNTED COMPONENTS INSTALLATION</b>	Ref.	
	0251917	<b>LIMIT SWITCHES INSTALLATION</b>	Ref.	A
-1	0901771	Bracket, Mounting	1	
-2	4360300	Switch, Limit	2	
-3	4460049	Connector, Strain Relief	2	
-4	4751500	Flatwasher 5/16"	2	
-5	4761500	Lockwasher 5/16"	2	
-6	3311501	Nut 5/16"-18NC	2	
-7	3440413	Rollpin 1/8" x 13/16"	1	
-8	1100062	Cam (Hi-Drive Cutout)	1	
-9	0641612	Bolt 3/8"-16NC x 1 1/2"	2	
-10	4761600	Lockwasher 3/8"	2	
-11	1100063	Cam (Drive Cutout)	1	
-12	0641614	Bolt 3/8"-16NC x 1 3/4"	2	
-13	4751600	Flatwasher 3/8"	4	
-14	3311605	Locknut 3/8"-16NC	2	
-15	3440420	Rollpin	2	
-16	3930832	Bolt, Socket Head #8-32NC x 2"	8	
-17	4750800	Flatwasher #8	8	
-18	4760800	Lockwasher #8	8	
-19	3310801	Nut #8-32NC	8	
		<b>LADDER INSTALLATION (STANDARD PARTS)</b>	Ref.	
-101	Not Used			
-102	0641612	Bolt 3/8"-16NC x 1 1/2"	A/R	
-103	4751600	Flatwasher 3/8"	A/R	
-104	4761600	Lockwasher 3/8"	A/R	
-105	3311601	Nut 3/8"-16NC	A/R	
	1281332	<b>LADDER INSTALLATIONS - (VARIABLE PARTS)</b>	Ref.	C
	4843625	Ladder Weldment - CM25RT	1	
	4843626	Ladder Weldment - CM33RT	1	
	4843993	Ladder Weldment - CM40RT	1	
		<b>ALARM INSTALLATIONS (OPTIONAL) (STANDARD PARTS WHEN EQUIPPED)</b>	Ref.	
-201	Not Used			
-202	4300038	Stud (Welded on Part)	2	
-203	4761500	Lockwasher 5/16"	2	
-204	3311501	Nut 5/16"-18NC	2	
-205	4751500	Flatwasher 5/16"	2	
	1281221	<b>ALARMS INSTALLATIONS (OPTIONAL ON GAS (DIESEL MACHINES BUILT PRIOR TO APRIL 1992) (VARIABLE PARTS WHEN EQUIPPED)</b>	Ref.	B
	1281810	<b>ALARMS INSTALLATIONS (OPTIONAL ON GAS/DIESEL MACHINES BUILT APRIL 1992 TO PRESENT) (VARIABLE PARTS WHEN EQUIPPED)</b>	Ref.	—
-251	0140024	Alarm (Gas/Diesel Machines)	1	

## SECTION 1      FRAME

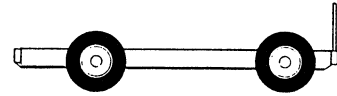

FIGURE & ITEM NO	PART NUMBER	DESCRIPTION	QTY.	REV.
1—8		<b>FRAME MOUNTED COMPONENTS INSTALLATION (CONTINUED)</b>	Ref.	
	3990010	Diode - 6 Amp (Not Shown - Located at Ground Control)	A/R	
	3740049	Relay (Not Shown - Located at Ground Control)	1	
	1281280	<b>ALARMS INSTALLATION (OPTIONAL ON ELECTRIC MACHINES BUILT PRIOR TO APRIL 1992) (VARIABLE PARTS WHEN EQUIPPED)</b>	Ref.	B
—252	0140026	Alarm	1	
—253	0860617	Box Assembly	1	
—254	3941406	Screw, Self-Tapping	2	
—255	4460049	Connector, Strain Relief	1	
	3300047	Nut, Conduit	1	
	3990010	Diode - 6 Amp (Not Shown - Located at Ground Controls)	A/R	
	1281813	<b>ALARMS INSTALLATION (OPTIONAL ON ELECTRIC MACHINES BUILT APRIL 1992 TO PRESENT) (VARIABLE PARTS WHEN EQUIPPED)</b>	Ref.	—
—256	0140025	Alarm (Electric Machines)	1	
	3990010	Diode - 6 Amp (Not Shown - Located at Ground Control)	A/R	
	0251800	<b>HEADLIGHTS AND TAILLIGHTS INSTALLATION (OPTIONAL) (STANDARD PARTS WHEN EQUIPPED)</b>	Ref.	—
—301	2920019	Taillight	2	
—302	0901382	Bracket, Taillight	2	
—303	2920001	Headlight	2	
—304	0900446	Bracket, Headlight	2	
—305	0641608	Bolt 3/8"-16NC x 1"	4	
—306	4761600	Lockwasher 3/8"	4	
—307	3311601	Nut 3/8"-16NC	4	
	4360199	Switch, Toggle - SPST (Not Shown - Located at Platform Controls)	1	
	3790012	O-Ring	1	
	4060229	Shield, Switch	1	
	3250630	Nametag - Headlights	1	
	1281556	<b>HYDRAULIC LEVELING JACKS INSTALLATION (STANDARD PARTS WHEN EQUIPPED)</b>	Ref.	D
—401	4843866	Tube, Outrigger	4	
—402	1682657	Jack Cylinder Assembly (See Section 5 for Breakdown)	4	
—403	0630327	U-Bolt	8	
—404	4761800	Lockwasher 1/2"	16	
—405	3311801	Nut 1/2"-13NC	16	
—406	0642232	Bolt 3/4"-10NC x 4"	4	
—407	4762200	Lockwasher 3/4"	4	
—408	3312201	Nut 3/4"-10NC	4	
—409	1700626	Decal - Caution	4	

# SECTION 1

# FRAME

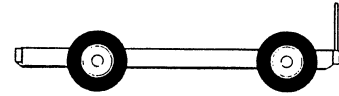

FIGURE & ITEM NO	PART NUMBER	DESCRIPTION	QTY.	REV.
------------------	-------------	-------------	------	------

FIGURE & ITEM NO	PART NUMBER	DESCRIPTION	QTY.	REV.
1-8		<b>FRAME MOUNTED COMPONENTS INSTALLATION (CONTINUED)</b>	Ref.	
	0252529	<b>LIMIT SWITCH INSTALLATION (OVERLOAD/TILT INTERLOCK) (FRENCH SPEC)</b>	Ref.	B
-501	4360236	Head, Switch	1	
-502	4360277	Switch, Limit	1	
-503	3900168	Bolt, Socket #10-24NC x 1 1/2"	2	
-504	4360237	Arm and Roller	1	
-505	4460052	Connector, Strain Relief	1	

SECTION 1 FRAME



# SECTION 2 GROUND COMPONENTS

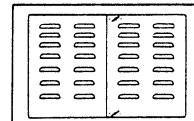

## TABLE OF CONTENTS

FIGURE NO.	DESCRIPTION	PAGE NO.
2-1	Control Valves and Tanks Installation - Gas/Diesel Machines . . . .	2-2
2-2	Control Valves Assembly - Racine Bang-Bang (Gas/ Diesel Machines) . . . . .	2-6
2-3	Control Valve Assembly - Racine 2 Stack (Electric Machines) . . .	2-10
2-4	Control Valve Assembly - Racine 2 Stack (Electric Machines) . . .	2-12
2-5	Modular Control Valve Assembly (Electric Machines) . . . . .	2-14
2-6	Control Valve Assembly - FPS 4 Stack . . . . .	2-16
2-7	Engine Installation - Ford VSG-411 . . . . .	2-20
2-8	Dual Fuel Installation . . . . .	2-26
2-9	110V Generator Installation - Ford . . . . .	2-28
2-10	Engine Installation - Deutz . . . . .	2-30
2-11	110V Generator Installation . . . . .	2-36
2-12	Pump Assembly - Sunstrand . . . . .	2-38
2-13	Electrical Components Installation (Electric Machines Only) . . . . .	2-42
2-14	Battery Charger Assembly (Electric Machines Only) . . . . .	2-46
2-15	Ground Control Box Assembly and Installation . . . . .	2-48
2-16	Hoods and Beacon Light Installation . . . . .	2-52

SECTION 2 GROUND COMPONENTS

# SECTION 2 GROUND COMPONENTS

FIGURE 2-1. CONTROL VALVES AND TANKS INSTALLATION.

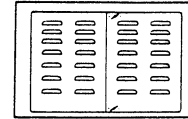

SECTION 2 GROUND COMPONENTS

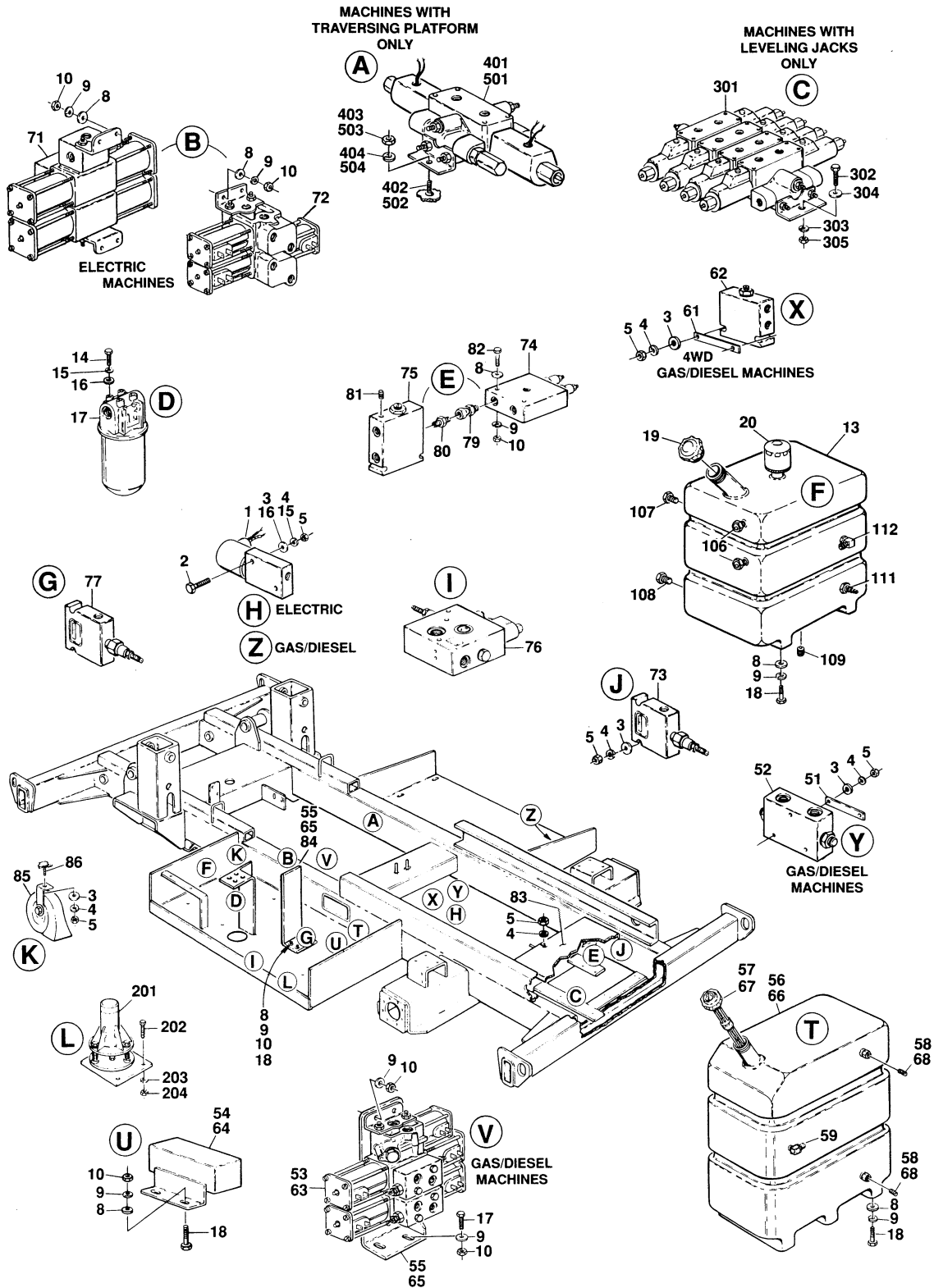

# SECTION 2 GROUND COMPONENTS

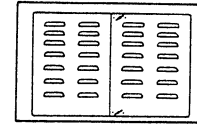

# SECTION 2 GROUND COMPONENTS

FIGURE & ITEM NO	PART NUMBER	DESCRIPTION	QTY.	REV.
2-1		<b>CONTROL VALVES AND TANKS INSTALLATION</b>	Ref.	
		<b>CONTROL VALVES AND TANKS INSTALLATION (STANDARD PARTS)</b>	Ref.	
-1	4640123	Solenoid Valve Assembly	1	
	7004368	Coil (Hydraforce Version)	1	
	7000558	Coil (FPS Version)	1	
	7012518	Seal Kit (Hydraforce Version)	1	
	7006075	Seal Kit (FPS Version)	1	
-2	0641420	Bolt 1/4"-20NC x 2 1/2"	A/R	
-3	4751400	Flatwasher 1/4"	A/R	
-4	4761400	Locknut 1/4"	A/R	
-5	3311401	Nut 1/4"-20NC	A/R	
-6	Not Used			
-7	Not Used			
-8	4751600	Flatwasher 3/8"	A/R	
-9	4761600	Lockwasher 3/8"	A/R	
-10	3311601	Nut 3/8"-16NC	A/R	
-11	Not Used			
-12	Not Used			
-13	4400282	Hydraulic Tank Assembly (See items 101-112 for Breakdown)	1	
-14	0641506	Bolt 5/16"-18NC x 3/4"	4	
-15	4761500	Lockwasher 5/16"	A/R	
-17	2120109	Filter Assembly	1	
	2120110	Element, Filter	1	
-18	0641608	Bolt 3/8"-16NC x 1"	A/R	
-19	1120361	Cap, Hydraulic Tank	1	
-20	1340021	Breather	1	
	0252454	<b>CONTROL VALVES AND TANKS INSTALLATION - 2WD GAS AND DIESEL MACHINES (VARIABLE PARTS)</b>	Ref.	A
-51	3010099	Link	1	
-52	4640629	Flow Divider Valve Assembly	1	
-53	4640578	Control Valve Assembly - Racine Bang-Bang (See Figure 2-2 for Breakdown)	1	
-54	3100069	Block, Manifold	1	
-55	0901816	Bracket, Valve Mounting	1	
-56	4400273	Fuel Tank Assembly	1	
-57	1120362	Cap, Fuel	1	
-58	2200202	Plug, Pipe	3	
-59	2220317	Fitting, Coupling	1	
	0100043	----- Sealant	A/R	
	0252453	<b>CONTROL VALVES AND TANKS INSTALLATION - 4WD GAS AND DIESEL MACHINES (VARIABLE PARTS)</b>	Ref.	A
-61	3010099	Link	2	
-62	4640260	Flow Divider Valve Assembly	2	

# SECTION 2 GROUND COMPONENTS

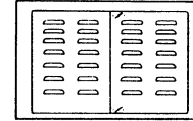

SECTION 2 GROUND COMPONENTS

FIGURE & ITEM NO	PART NUMBER	DESCRIPTION	QTY.	REV.
2-1		<b>CONTROL VALVES AND TANKS INSTALLATION (CONTINUED)</b>	Ref.	
-63	4640578	Control Valve Assembly - Racine Bang-Bang (See Figure 2-2 for Breakdown)	1	
-64	3100069	Block, Manifold	1	
-65	0901816	Bracket, Valve Mounting	1	
-66	4400273	Fuel Tank Assembly	1	
-67	1120362	Cap, Fuel	1	
-68	2200202	Plug, Pipe	3	
-69	2220317	Fitting, Coupling	1	
	0100043	Sealant	A/R	
	0251851	<b>CONTROL VALVES AND TANK INSTALLATION - ELECTRIC MACHINES (VARIABLE PARTS)</b>	Ref.	C
-71	4640597	Control Valve Assembly - Racine 2 Stack (See Figure 2-3 for Breakdown)	1	
-72	4640399	Control Valve Assembly - Racine 2 Stack (See Figure 2-4 for Breakdown)	1	
-73	4640632	Valve, Pressure Reducing	1	
	4640523	Cartridge	1	
	2900698	Seal Kit	1	
-74	4640529	Valve, Counterbalance	1	
	4640729	Cartridge	1	
	7004293	Seal Kit	1	
-75	4640260	Valve, Flow Divider (Not Field Serviceable)	1	
-76	4640598	Modular Control Valve Assembly (See Figure 2-5 for Breakdown)	1	
-77	4640533	Valve, Sequence	1	
	7010529	Cartridge	1	
	2900698	Seal Kit	1	
-78	Not Used			
-79	2220451	Fitting	1	
-80	2220594	Fitting	1	
-81	2220235	Plug	1	
-82	0641620	Bolt 3/8"-16NC x 2 1/2"	2	
-83	3534228	Plate, Cover	1	
-84	0901684	Bracket, Valve Mounting	1	
-85	0140028	Horn	1	
-86	4300031	Stud (Welded on Part)	1	
	4400282	<b>HYDRAULIC TANK ASSEMBLY</b>	Ref.	
-101	4400274	Tank, Hydraulic	1	
-102	Not Used			
-103	Not Used			
-104	Not Used			



# SECTION 2 GROUND COMPONENTS

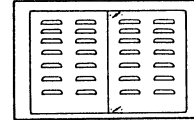
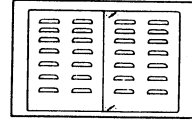

FIGURE & ITEM NO	PART NUMBER	DESCRIPTION	QTY.	REV.
2-1		<b>CONTROL VALVES AND TANKS INSTALLATION (CONTINUED)</b>	Ref.	
-105	Not Used			
-106	2420115	Gauge, Sight	2	
-107	2220240	Plug	1	
-108	2220242	Plug	1	
-109	3520022	Plug, Magnetic	1	
-110	Not Used			
-111	2210066	Fitting	1	
-112	2180745	Fitting, Modified	1	
	0251416	<b>TILT INDICATOR INSTALLATION</b>	Ref.	A
-201	4360280	Sensor, Level	1	
-202	0641406	Bolt 1/4"-20NC x 3/4"	3	
-203	4761400	Lockwasher 1/4"	3	
-204	3311401	Nut 1/4"-20NC	3	
	1060016	Cable, Electrical 16/3 (Not Shown)	6 ft/1.8m	
	0250152	<b>CONTROL VALVE INSTALLATION - HYDRAULIC LEVELING JACKS OPTION</b>	Ref.	—
-301	4640352	Control Valve Assembly - FPS 4 Stack (See Figure 2-6 for Breakdown)	1	
-302	0641608	Bolt 3/8"-16NC x 1"	2	
-303	4761600	Lockwasher 3/8"	2	
-304	4751600	Flatwasher 3/8"	2	
-305	3311601	Nut 3/8"-16NC	2	
	1281610	<b>CONTROL VALVE INSTALLATION - TRAVERSING PLATFORM OPTION "WITH" HYDRAULIC LEVELING JACKS OPTION</b>	Ref.	—
-401	4640516	Control Valve Assembly - FPS (See Figure 2-6 for Breakdown)	1	
-402	4300034	Stud (Welded on Part)	2	
-403	3311601	Nut 3/8"-16NC	2	
-404	4761600	Lockwasher 3/8"	2	
	1281563	<b>CONTROL VALVE INSTALLATION - TRAVERSING PLATFORM OPTION WITHOUT HYDRAULIC LEVELING JACKS OPTION</b>	Ref.	—
-501	4640375	Control Valve Assembly - FPS (See Figure 2-6 for Breakdown)	1	
-502	4300034	Stud (Welded on Part)	2	
-503	3311601	Nut 3/8"-16NC	2	
-504	4761600	Lockwasher 3/8"	2	

SECTION 2 GROUND COMPONENTS

# SECTION 2 GROUND COMPONENTS

FIGURE 2-2. CONTROL VALVE ASSEMBLY - RACINE BANG-BANG (GAS AND DIESEL MACHINES).



SECTION 2  
GROUND COMPONENTS

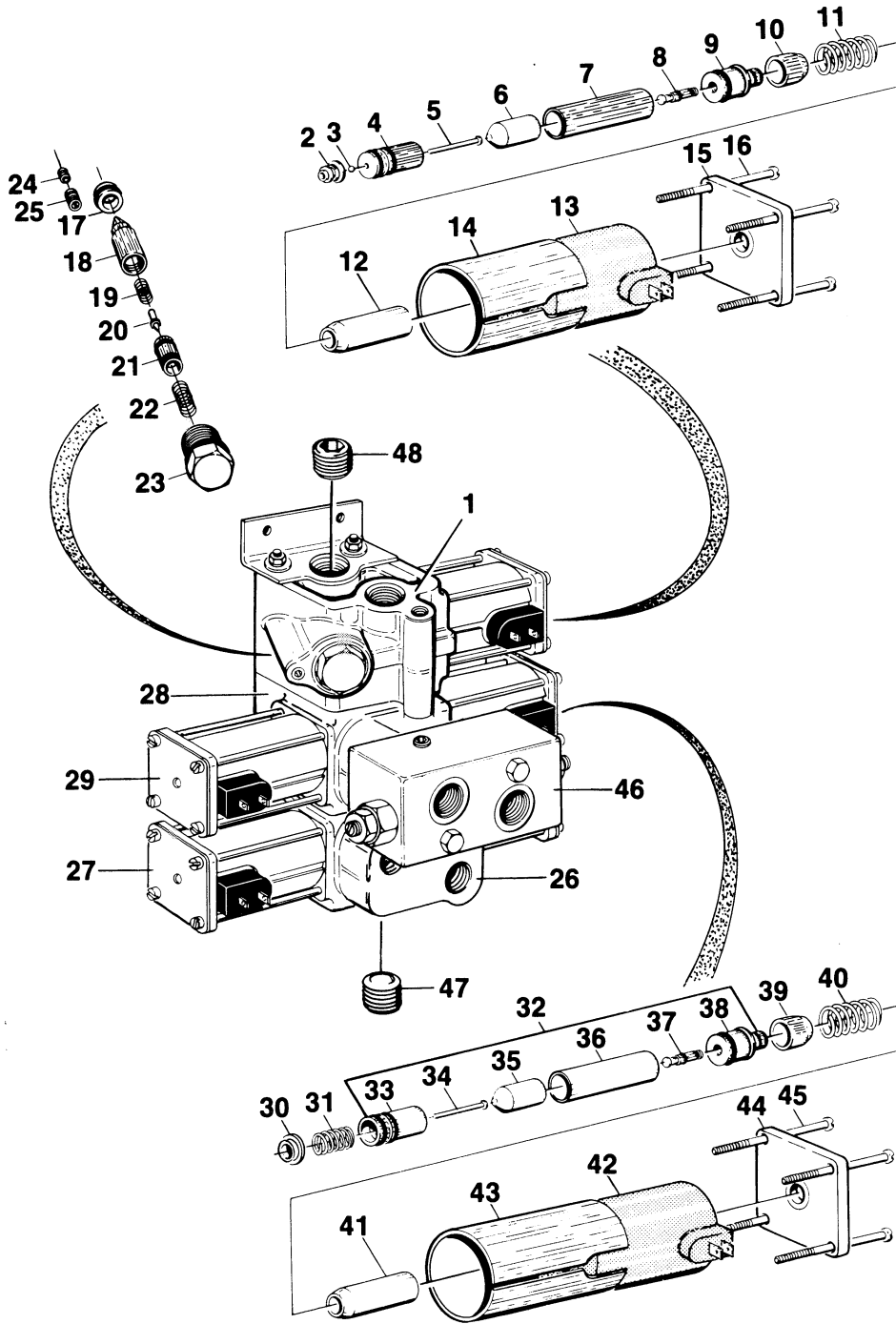

# SECTION 2 GROUND COMPONENTS

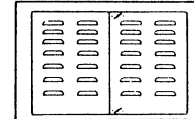

SECTION 2 GROUND COMPONENTS

FIGURE & ITEM NO	PART NUMBER	DESCRIPTION	QTY.	REV.
2-2	4640578	<b>CONTROL VALVE ASSEMBLY - RACINE BANG- (GAS AND DIESEL MACHINES)</b>	Ref.	—
—1	7002304	Dump Section - Complete	1	
		Solenoid Assembly	1	
—2	7004823	Seat	1	
	Kit	O-Ring	1	
—3	7002229	Ball	1	
		Guide Tube Assembly	1	
—4	7004822	Cone, Female	1	
	Kit	O-Ring	1	
—5	7002346	Pin, Push	1	
—6	7004839	Plunger	1	
—7	7004838	Tube, Guide	1	
—8	7004841	Pin, Push	1	
	Kit	O-Ring	1	
—9	7002340	Guide, External Push Pin	1	
	Kit	O-Ring	1	
—10	7004834	Sleeve, Inner Flux	1	
—11	7002334	Spring	1	
—12	7004835	Sleeve, Outer Flux	1	
—13	7000417	Coil	1	
—14	7004836	Case, Solenoid	1	
—15	7002338	Plate, End	1	
—16	7004837	Screw	4	
—17	7002322	Seat	1	
	Kit	O-Ring	1	
		Main Relief (Poppet) Valve	1	
—18	7002321	Case, Poppet	1	
—19	7002328	Spring	1	
—20	7002294	Poppet	1	
—21	7002320	Seat, Adjustable	1	
	Kit	O-Ring	1	
—22	7002329	Spring	1	
—23	7002323	Plug	1	
	Kit	O-Ring	1	
—24	7002326	Orifice	1	
—25	7002324	Plug	1	
—26	7004894	Working Section- Complete	1	
—27	7004859	Solenoid Assembly (Refer to Items 30-45 for Serviced Parts)	2	
—28	7002315	Working Section - Complete	1	
—29	7004859	Solenoid Assembly	2	
—30	7003825	Washer, Hat (2 Per Section)	4	
—31	7002348	Spring (2 Per Section)	4	
—32	7002305	Guide Tube Assembly (2 Per Section)	4	
—33	7002345	Cone, Female (2 Per Section)	4	
	Kit	O-Ring (2 Per Section)	4	



# SECTION 2 GROUND COMPONENTS

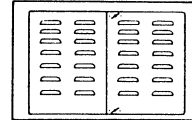
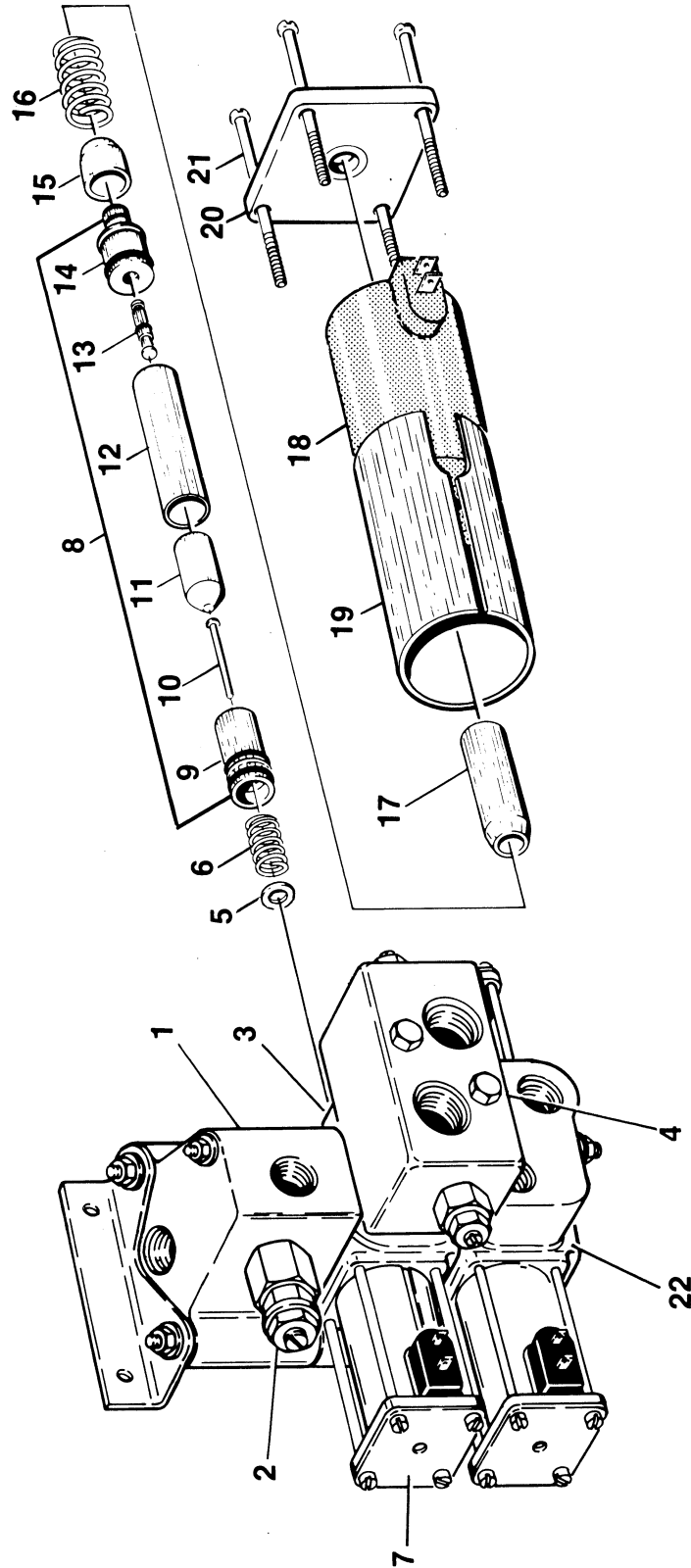
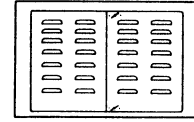

FIGURE & ITEM NO	PART NUMBER	DESCRIPTION	QTY.	REV.
2-2		<b>CONTROL VALVE ASSEMBLY - RACINE BANG-BANG (GAS AND DIESEL MACHINES) (CONTINUED)</b>	Ref.	—
	Kit	O-Ring (2 Per Section)	4	
—34	7002346	Pin, Push (2 Per Section)	4	
—35	7002344	Plunger (2 Per Section)	4	
—36	7000470	Tube, Guide (2 Per Section)	4	
—37	7002341	Pin, Actuator (2 Per Section)	4	
	Kit	Ring, Quad (2 Per Section)	4	
—38	7002340	Guide, External Push Pin (2 Per Section)	4	
	Kit	O-Ring (2 Per Section)	4	
—39	7002333	Sleeve, Inner Flux (2 Per Section)	4	
—40	7002334	Spring (2 Per Section)	4	
—41	7002336	Sleeve, Outer Flux (2 Per Section)	4	
—42	7000418	Coil (2 Per Section)	4	
—43	7002335	Case, Solenoid (2 Per Section)	4	
—44	7002338	Plate, End (2 Per Section)	4	
—45	7002339	Screw (4 Per Section)	8	
—46	7000468	Relief Valve Block Assembly (No Longer Field Serviceable)	1	
—47	2220237	Plug	1	
—48	2220238	Plug	1	
	7000414	Seal Kit - Working Section	2	
	7000413	Seal Kit - Dump Section	1	

SECTION 2 GROUND COMPONENTS

# SECTION 2 GROUND COMPONENTS

FIGURE 2-3. CONTROL VALVE ASSEMBLY - RACINE  
2 STACK (ELECTRIC MACHINES).



# SECTION 2 GROUND COMPONENTS

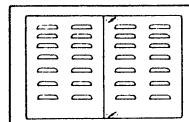

FIGURE & ITEM NO	PART NUMBER	DESCRIPTION	QTY.	REV.
2-3	4640597	<b>CONTROL VALVE ASSEMBLY - RACINE 2 STACK (ELECTRIC MACHINES)</b>	Ref.	A
-1	7002254	Inlet Relief Section Assembly	1	
-2	7000447	Cartridge	1	
-3	7000466	Valve Section - Complete	1	
-4	7000468	Relief Valve Block Assembly (No Longer Field Serviceable)	1	
-5	7002274	Washer (2 Per Section)	4	
-6	7002273	Spring (2 Per Section)	4	
-7		Solenoid Assembly (2 Per Section)	4	
-8	7004821	Guide Tube Assembly (1 Per Assembly)	4	
-9	7003830	Female Cone/O-Ring Assembly (1 Per Assembly)	4	
-10	7002346	Pin, Push (1 Per Assembly)	4	
-11	7002344	Plunger (1 Per Assembly)	4	
-12	7000470	Tube, Guide (1 Per Assembly)	4	
-13	7003829	Actuator Pin/Quad Ring Assembly (1 Per Assembly)	4	
-14	7003831	Pin Guide/O-Ring Assembly (1 Per Assembly)	4	
-15	7002333	Sleeve, Inner Flux (2 Per Section)	4	
-16	7002334	Spring (2 Per Section)	4	
-17	7002336	Sleeve, Outer Flux (2 Per Section)	4	
-18	7000418	Coil (2 Per Section)	4	
-19	7002335	Case, Solenoid (2 Per Section)	4	
-20	7002338	Plate, End (2 Per Section)	4	
-21	7002339	Screw (2 Per Section)	16	
-22	7003860	Valve Section - Complete (Refer to Items 5-21 for Serviced Parts)	1	
	7000414	Seal Kit - Working Section	2	
	7000413	Seal Kit - Inlet Relief	1	
	7002265	Mounting Hardware Kit	1	

SECTION 2 GROUND COMPONENTS

Updated 4/92

# SECTION 2 GROUND COMPONENTS

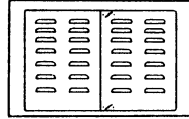
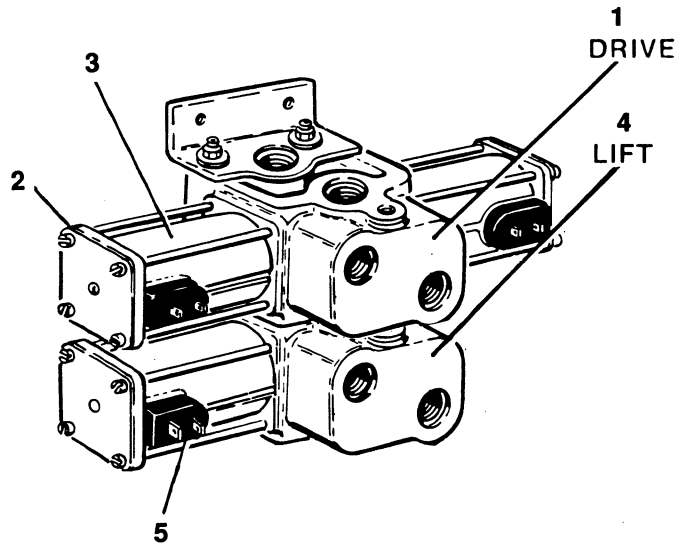

FIGURE 2-4. CONTROL VALVE ASSEMBLY - RACINE  
2 STACK (ELECTRIC MACHINES).

SECTION 2  
GROUND COMPONENTS





# SECTION 2 GROUND COMPONENTS

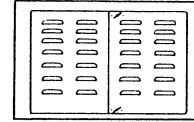

FIGURE & ITEM NO	PART NUMBER	DESCRIPTION	QTY.	REV.
2-4	4640399	<b>CONTROL VALVE ASSEMBLY - RACINE 2 STACK (ELECTRIC MACHINES)</b>	Ref.	B
-1	7004894	Section Assembly - Complete (Drive)	1	
	7003827	Spool	1	
	7003825	Washer, Hat	2	
	7002348	Spring	2	
-2	7004896	Guide Tube Assembly	2	
-3	7000418	Coil - 12VDC	2	
-4	7004895	Section Assembly - Complete (Lift)	1	
-5	7000418	Coil - 12VDC	1	
	7002347	O-Ring, Square (Small) (Located Between Sections)	1	
	7000448	O-Ring, Square (Large) (Located Between Sections)	1	
	7004893	Stacking Kit (Includes Brackets and Assembly Hardware)	1	

SECTION 2 GROUND COMPONENTS

Updated 4/92

# SECTION 2 GROUND COMPONENTS

FIGURE 2-5. MODULAR CONTROL VALVE ASSEMBLY  
(ELECTRIC MACHINES).

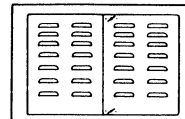

SECTION 2  
GROUND COMPONENTS

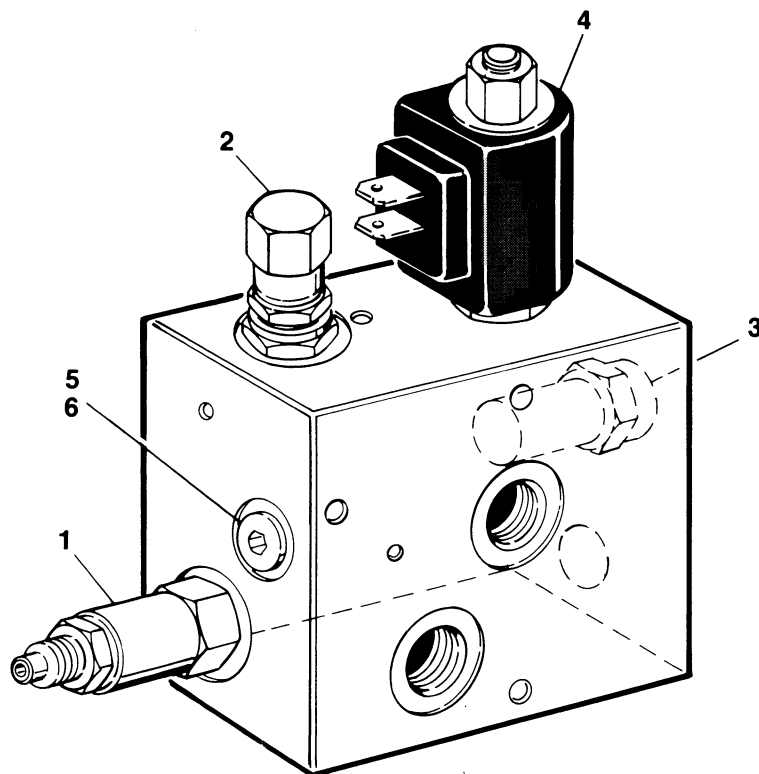

# SECTION 2 GROUND COMPONENTS

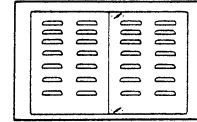
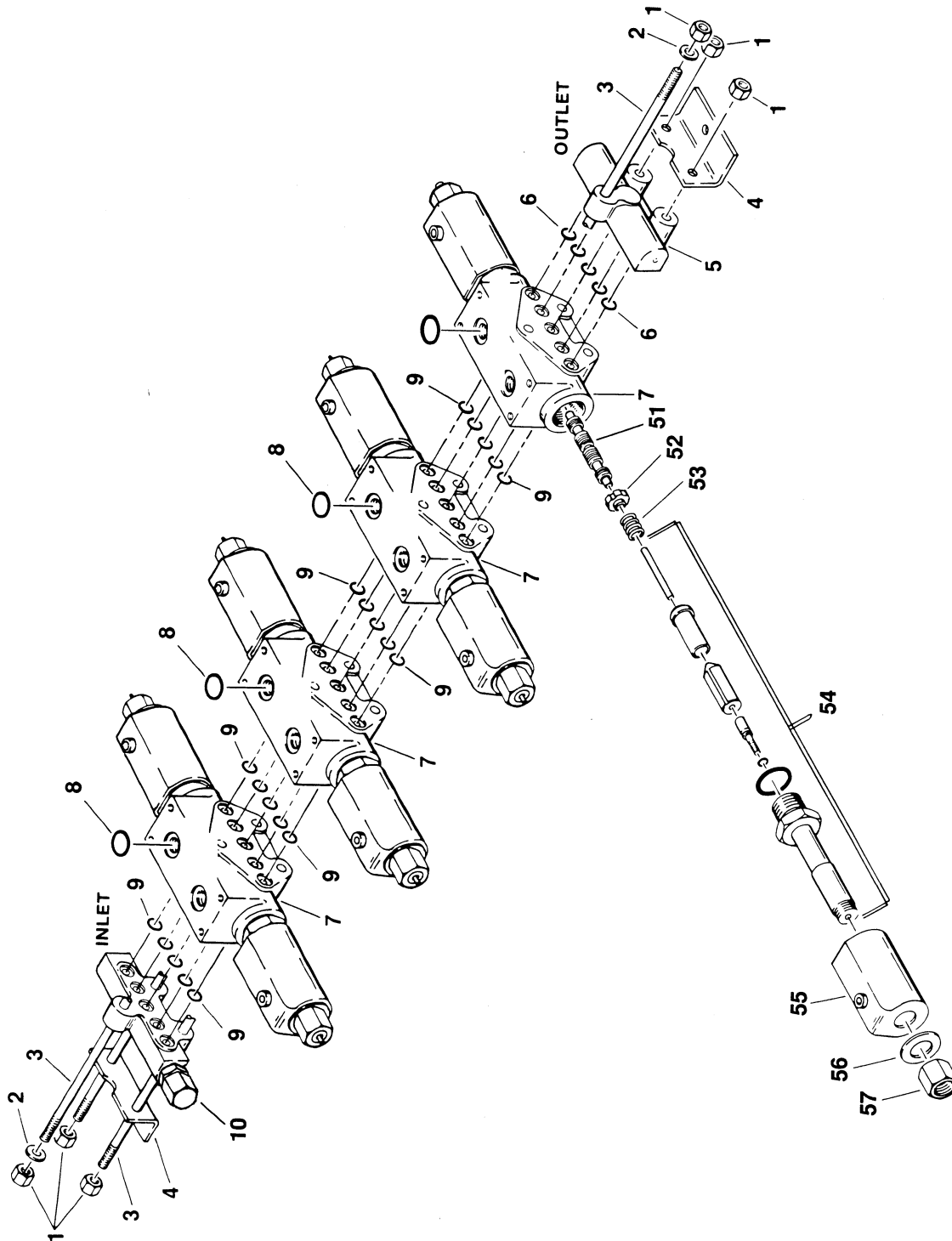
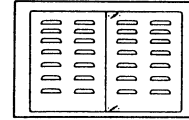

FIGURE & ITEM NO	PART NUMBER	DESCRIPTION	QTY.	REV.
2—5	4640598	<b>MODULAR CONTROL VALVE ASSEMBLY (ELECTRIC MACHINES)</b>	Ref.	A
—1	7010511	Cartridge, Differ, Pressure Sensing	1	
—2	7010512	Cartridge, Relief	1	
—3	7010513	Cartridge, Modulating Orifice Spool	1	
—4	7010514	Cartridge, Electric/Hydraulic Relief	1	
	7009742	Coil - 12VDC	1	
	7010516	Nut	1	
—5	7010515	Orifice	1	
—6	7004232	Plug	1	
	2900735	Seal Kit (Item 1)	1	
	2900503	Seal Kit (Items 2 and 4)	2	
	2900736	Seal Kit (Item 3)	1	

SECTION 2 GROUND COMPONENTS

# SECTION 2 GROUND COMPONENTS

FIGURE 2-6. CONTROL VALVE ASSEMBLY - FPS (LEVELING JACKS OPTION AND TRAVERSING PLATFORM OPTION).



# SECTION 2 GROUND COMPONENTS

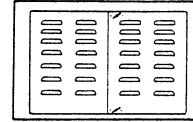

SECTION 2 GROUND COMPONENTS

FIGURE & ITEM NO	PART NUMBER	DESCRIPTION	QTY.	REV.
2-6		<b>CONTROL VALVE ASSEMBLY - FPS (LEVELING JACKS OPTION AND TRAVERSING PLATFORM OPTION)</b>	Ref.	
		<b>CONTROL VALVE ASSEMBLY (STANDARD PARTS)</b>	Ref.	
-1	7000585	Nut	6	
-2	7000586	Washer	2	
-3		Rod, Tie	3	
-4	7006039	Bracket, Mounting	2	
-5	Not Used			
-6	Kit	O-Ring	5	
-7	7006041	Valve Section - Complete (See Items 51-57 for Breakdown)	A/R	
-8	Kit	O-Ring (2 Per Section)	A/R	
-9	Kit	O-Ring (5 Per Section)	A/R	
-10	7006040	Inlet Section - Complete	1	
	7006053	Cartridge, Relief	1	
	7006041	<b>VALVE SECTION ASSEMBLY - COMPLETE</b>	Ref.	
-51	Not Available	Spool (Not Sold Separately)	1	
-52	7006037	Retainer, Spring	2	
-53	7006036	Spring	2	
-54	7006034	Tube Assembly	2	
	Kit	O-Ring (1 Per Side)	2	
	Kit	O-Ring (1 Per Side)	2	
-55	4640049	Coil, Solenoid	2	
-56	Not Available	Nameplate (Not Sold Separately)	2	
-57	7006033	Nut	2	
	4640352	<b>CONTROL VALVE ASSEMBLY - FPS 4 SECTION (LEVELING JACKS OPTION) (VARIABLE PARTS)</b>	Ref.	B
-101	7000600	Outlet Section - Complete	1	
	7000549	Seal Kit - Valve Section (Includes Items 8 and 9 and Item 54 O-Rings)	4	
	7000550	Seal Kit - Inlet Relief	1	
	4640516	<b>CONTROL VALVE ASSEMBLY - FPS SINGLE SECTION (TRAVERSING PLATFORM OPTION WITH LEVELING JACKS OPTION) (VARIABLE PARTS)</b>	Ref.	—
-201	7006042	Outlet Section - Complete	1	
	7000549	Seal Kit - Valve Section (Includes Items 8 and 9 and Item 54 O-Rings)	1	



# SECTION 2 GROUND COMPONENTS

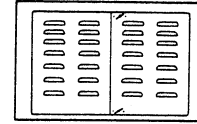
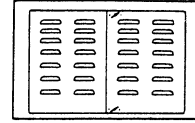

FIGURE & ITEM NO	PART NUMBER	DESCRIPTION	QTY.	REV.
2-6		<b>CONTROL VALVE ASSEMBLY - FPS (LEVELING JACKS OPTION AND TRAVERSING PLATFORM OPTION) (CONTINUED)</b>	Ref.	
	7000550	Seal Kit - Inlet Relief	1	
	2900657	Seal Kit - Outlet With Power Beyond	1	
	4640375	<b>CONTROL VALVE ASSEMBLY - FPS SINGLE SECTION (TRAVERSING PLATFORM OPTION WITHOUT LEVELING JACK OPTION) (VARIABLE PARTS)</b>	Ref.	C
-301	7000600	Outlet Section - Complete	1	
	7000549	Seal Kit - Valve Section (Includes Items 8 and 9 and Item 54 O-Rings)	1	
	7000550	Seal Kit - Inlet Relief	1	

SECTION 2 GROUND COMPONENTS

# SECTION 2 GROUND COMPONENTS

FIGURE 2-7. ENGINE INSTALLATION - FORD VSG-411.



SECTION 2 GROUND COMPONENTS

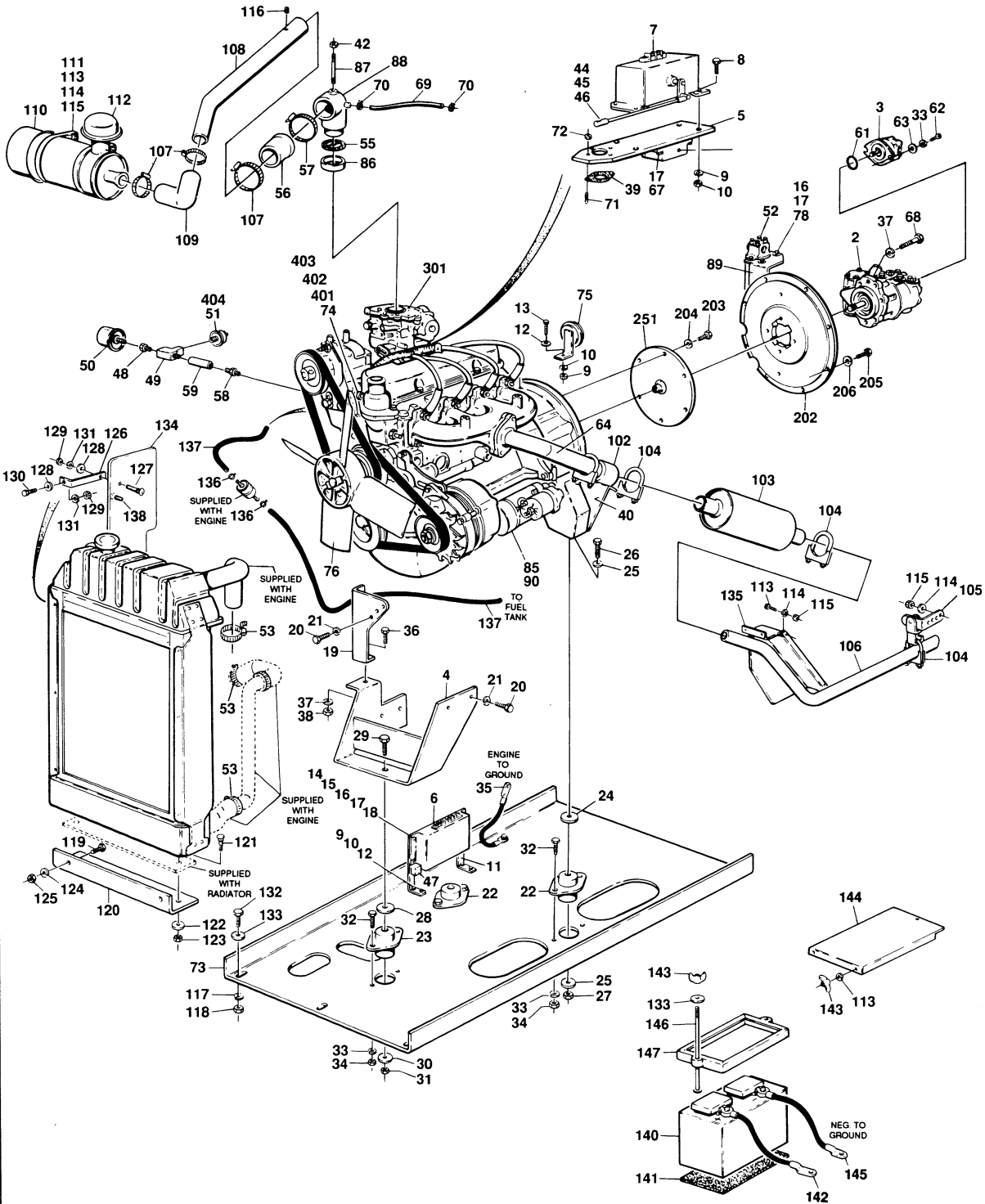



# SECTION 2 GROUND COMPONENTS

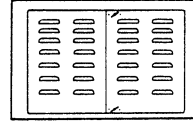
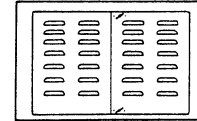

FIGURE & ITEM NO	PART NUMBER	DESCRIPTION	QTY.	REV.
2-7		ENGINE INSTALLATION - FORD VSG-411	Ref.	
	1281731	ENGINE ASSEMBLY (STANDARD PARTS)	Ref.	A
	1281842	ENGINE ASSEMBLY (STANDARD PARTS)	Ref.	—
—1	Not Used			
—2	3600164	Pump Assembly - Sunstrand (See Figure 2-12 for Breakdown)	1	
—3	3600188	Pump Assembly - Barnes	1	
	2900660	Shaft Seal Kit	1	
—4	4843497	Bracket, Engine Mounting	1	
—5	3533445	Plate, Governor and Carburetor Mounting	1	
—6	1600117	Controller, Governor	1	
—7	2500005	Governor, Precision	1	
—8	0641410	Bolt 1/4"-20NC x 1 1/4"	4	
—9	4761400	Lockwasher 1/4"	9	
—10	3311401	Nut 1/4"-20NC	9	
—11	0901419	Bracket, Controller	2	
—12	4751400	Flatwasher 1/4"	5	
—13	0641408	Bolt 1/4"-20NC x 1"	1	
—14	3911012	Screw, Machine #10-24NC x 3/4"	4	
—15	3311001	Nut #10-24NC	4	
—16	4751000	Flatwasher #10	6	
—17	4761000	Lockwasher #10	8	
—18	0100009	Adhesive	A/R	
—19	3533291	Plate, Engine	1	
—20	0701014	Bolt, Metric M10 x 30MM	5	
—21	4832000	Lockwasher, Metric M10	5	
—22	3200202	Mount, Engine - Rear	2	
—23	3200201	Mount, Engine - Front	1	
—24	4740273	Washer, Snubbing	2	
—25	4751700	Flatwasher 7/16"	4	
—26	0641726	Bolt 7/16" - 14NC x 3 1/4"	2	
—27	3311705	Locknut 7/16" - 14NC	2	
—28	4740274	Washer, Snubbing	1	
—29	0641826	Bolt 1/2"-13NC x 3 1/4"	1	
—30	4751800	Flatwasher 1/2"	1	
—31	3311805	Locknut 1/2"-13NC	1	
—32	0641608	Bolt 3/8"-16NC x 1"	8	
—33	4761600	Lockwasher 3/8"	8	
—34	3311601	Nut 3/8"-16NC	8	
—35	1060221	Cable, Battery (Engine to Ground)	1	
—36	0641812	Bolt 1/2"-13NC x 1 1/2"	2	
—37	4761800	Lockwasher 1/2"	4	
—38	3311801	Nut 1/2"-13NC	2	
—39	3960392	Gasket, Carburetor	1	
—40	3533646	Plate, Exhaust Support	1	
—41	Not Used			
—42	3311405	Locknut 1/4"-20NC	1	

SECTION 2 GROUND COMPONENTS

# SECTION 2 GROUND COMPONENTS



SECTION 2 GROUND COMPONENTS

FIGURE & ITEM NO	PART NUMBER	DESCRIPTION	QTY.	REV.
2-8		<b>ENGINE INSTALLATION - FORD VSG-411 (CONTINUED)</b>	Ref.	
-43	Not Used			
-44	3841049	Rod, Throttle	1	
-45	3321402	Nut, Jam 1/4"-28NF	2	
-46	1660157	Ball-joint	2	
-47	3740080	Relay, Bosch	1	
-48	2220273	Fitting, Reducer	1	
-49	2180360	Fitting, Tee	1	
-50	2420033	Sender, Oil Pressure	1	
-51	4360037	Switch, Pressure	1	
-52	2120135	Filter, Pressure	1	
	2120136	Element, Filter	1	
-53	1320014	Clamp, Hose	2	
-54	Not Used			
-55	3960388	Gasket	1	
-56	2720341	Hose - Air Cleaner Outlet	1	
-57	1320058	Clamp, Hose	1	
-58	2180537	Fitting, Nipple	1	
-59	2200261	Fitting, Pipe Coupling	1	
-60	Not Used			
-61	3790152	O-Ring	1	
-62	0641610	Bolt 3/8"-16NC x 1 1/4"	2	
-63	4740185	Washer, Hardened	2	
-64	4564564	Tube, Exhaust	1	
-65	Not Used			
-66	Not Used			
-67	3911014	Screw, Machne #10-24NC x 7/8"	2	
-68	0641810	Bolt 1/2"-13NC x 1 1/4"	2	
-69	2720042	Hose	18 in/46cm	
-70	1320032	Clamp	2	
-71	4300090	Stud	1	
-72	3321501	Nut 5/16"-24NF	2	
-73	3533648	Plate, Engine Mounting	1	
-74	2420118	Sender, Temperature	1	
-75	0140001	Horn	1	
-76	2060019	Fan and Spacer Kit	1	
-77	Not Used			
-78	0721008	Screw, Machine #10-24NC x 1"	2	
		<b>ENGINE ASSEMBLY - STANDARD GAS (VARIABLE PARTS)</b>	Ref.	
-85	2000109	Engine (Machines Built Prior to June 1992)	1	
	2000117	Engine (Machines Built June 1992 to Present)	1	
-86	0080092	Adapter, Carburetor	1	
-87	4300056	Stud	1	
-88	0080175	Adapter, Air Intake	1	
-89	0901778	Bracket	1	

# SECTION 2 GROUND COMPONENTS

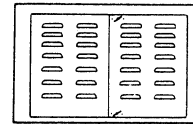
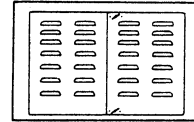

FIGURE & ITEM NO	PART NUMBER	DESCRIPTION	QTY.	REV.
2-7		<b>ENGINE INSTALLATION - FORD VSG-411 (CONTINUED)</b>	Ref.	
		<b>ENGINE ASSEMBLY - DUAL FUEL (VARIABLE PARTS)</b>	Ref.	
-90	2000109	Engine (Machines Built Prior to June 1992)	1	
	2000117	Engine (Machines Built June 1992 to Present)	1	
	1281731	<b>ENGINE INSTALLATION (STANDARD PARTS)</b>	Ref.	A
	1281842	<b>ENGINE INSTALLATION (STANDARD PARTS)</b>	Ref.	—
-101	Not Used			
-102	1660181	Connector, Exhaust	1	
-103	3220033	Muffler	1	
-104	1320019	U-Clamp	4	
-105	0901387	Bracket, Exhaust Hanger	1	
-106	4564683	Tailpipe	1	
-107	1320058	Clamp, Hose	3	
-108	4843533	Tube, Air Intake	1	
-109	0080039	Elbow, Rubber	1	
-110	1340020	Air Cleaner Assembly	1	
	7003655	Element	1	
-111	0340002	Band, Air Cleaner Mounting	2	
-112	1120161	Cap, Air Inlet	1	
-113	0641406	Bolt 1/4"-20NC x 3/4"	A/R	
-114	4761400	Lockwasher 1/4"	A/R	
-115	3311401	Nut 1/4"-20NC	A/R	
-116	2220053	Plug, Pipe	1	
-117	4761600	Lockwasher 3/8"	A/R	
-118	3311601	Nut 3/8"-16NC	A/R	
-119	0641710	Bolt 7/16"-14NC x 1 1/4"	2	
-120	3533663	Plate, Radiator Mounting	1	
-121	0630403	Bolt, Carriage 7/16"-14NC x 1 1/2"	2	
-122	4751700	Flatwasher 7/16"	2	
-123	3311705	Locknut 7/16"-14NC	2	
-124	4761700	Lockwasher 7/16"	2	
-125	3311701	Nut 7/16"-14NC	2	
-126	3533664	Plate, Radiator Support	1	
-127	0630360	Bolt, Carriage 5/16"-18NC x 1 1/4"	1	
-128	4751500	Flatwasher 5/16"	A/R	
-129	3311501	Nut 5/16"-18NC	A/R	
-130	0641508	Bolt 5/16"-18NC x 1"	1	
-131	4761500	Lockwasher 5/16"	2	
-132	0641610	Bolt 3/8"-16NC x 1 1/4"	6	
-133	4751600	Flatwasher 3/8"	15	
-134	4060713	Shield	1	
-135	4060736	Shield, Exhaust	1	
-136	1320022	Clamp	2	
-137	2720058	Hose, Fuel Line	6 ft./1.8m	
-138	3911008	Screw, Hex #10-24NC x 1/2"	3	

SECTION 2 GROUND COMPONENTS

# SECTION 2 GROUND COMPONENTS



SECTION 2 GROUND COMPONENTS

FIGURE & ITEM NO	PART NUMBER	DESCRIPTION	QTY.	REV.
2-7		<b>ENGINE INSTALLATION - FORD VSG-411 (CONTINUED)</b>	Ref.	
-139	Not Used			
-140	0400003	Battery	1	
-141	3980003	Masonite	1	
-142	1060406	Cable, Battery (Battery + to Starter Solenoid)	1	
-143	3300029	Wingnut 3/8"-16NC	A/R	
-144	1670621	Cover, Battery	1	
-145	1060046	Cable, Battery (Battery Neg to Ground)	1	
-146	0630370	Rod, Tie-Down	1	
-147	0400002	Tie-Down, Battery	1	
-148	Not Used			
	0250598	<b>PUMP COUPLING INSTALLATION (STANDARD PARTS)</b>	Ref.	—
-201	1660184	Coupling, Pump	1	
-202	0080163	Adapter, Pump Mounting	1	
-203	0700808	Bolt, Metric 8mm 1.25 x 16mm	6	
-204	4831900	Lockwasher, Metric 8mm	6	
-205	0641610	Bolt 3/8"-16NC x 1 1/4"	8	
-206	4761600	Lockwasher 3/8"	8	
	3020021	Grease, Coupling <b>Note: Coupling Spine must be greased with lithium soap based grease prior to installation.</b>	A/R	
	0250815	<b>ENGINE HEATER INSTALLATION (OPTIONAL - NOT SHOWN)</b>	Ref.	—
	2580026	Heater, Engine Coolant (Located at Rear of Cylinder Head)	1	
	0700820	Bolt, Metric 8m x 60mm	2	
	4564328	Spacer, Tube	2	
		<b>ENGINE COMPONENT REPLACEMENT PARTS</b>	Ref.	
-301	2900892	Carburetor (Standard Gas)	1	
	1140009	Carburetor (LP Gas)	1	
	7000878	Carburetor Rebuild Kit	1	
	7012578	Vacuum Line Assembly	1	
	7012577	Fitting, Vacuum Line	1	
	7012564	Harness, Wire (Engine)	1	
	7014680	Components Kit (Includes (1) Each of Carburetor, Water and Fuel Pumps, Starter, Alternator and Ignition Control)	1	
	7014681	Components Kit (Includes of Gasket Sets, Coil Hoses, Belt and Thermostat)	1	
	7014682	Tune-Up Kit (Includes Oil and Fuel Filters, Plugs and Ignition Wires)	1	

# SECTION 2 GROUND COMPONENTS

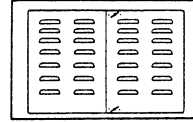
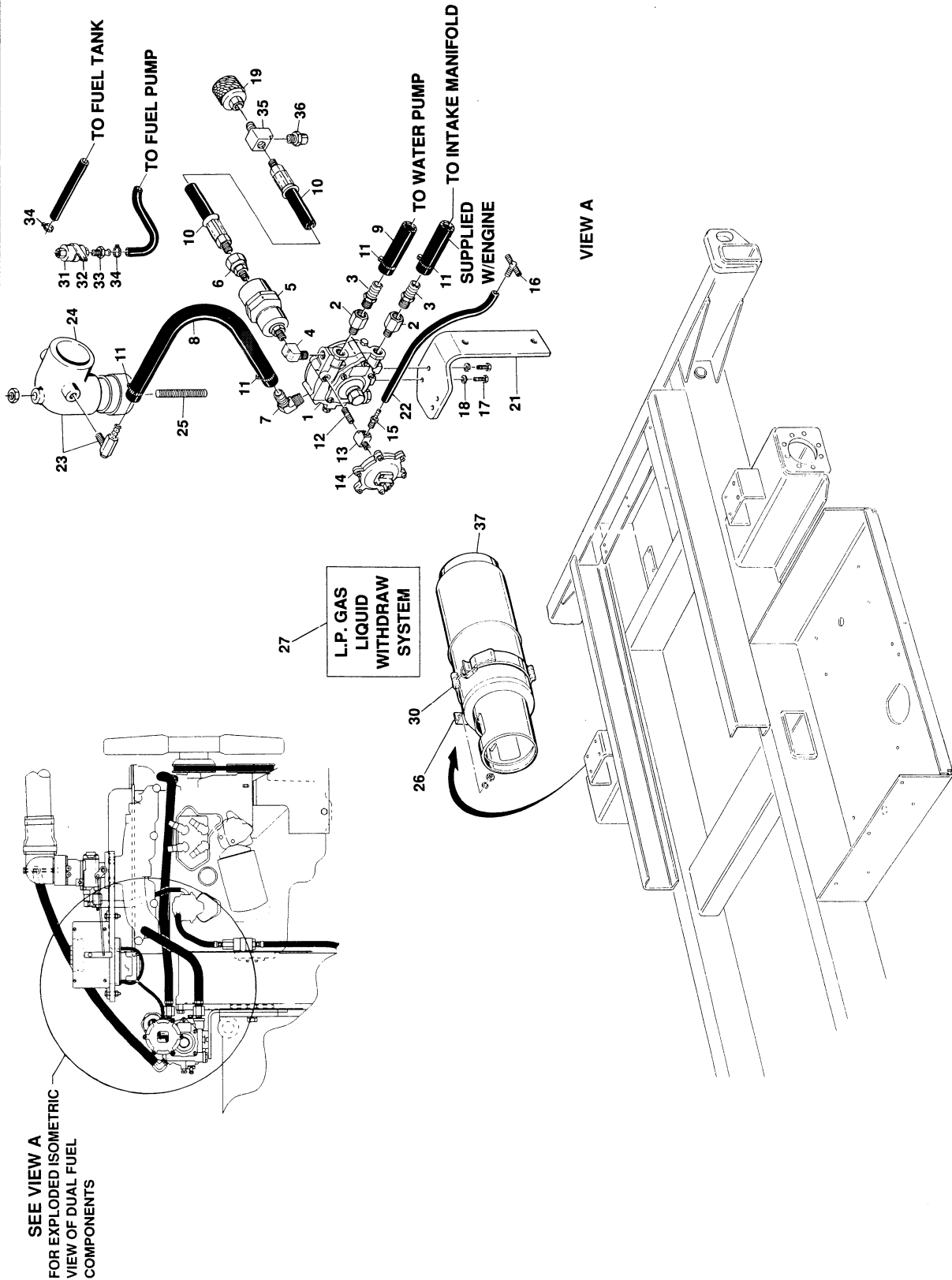
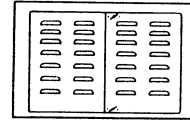

FIGURE & ITEM NO	PART NUMBER	DESCRIPTION	QTY.	REV.
2-7		<b>ENGINE INSTALLATION - FORD VSG-411 (CONTINUED)</b>	Ref.	
	0251945	<b>ENGINE DISTRESS SWITCH INSTALLATION</b>	Ref.	—
—401	2420130	Sender, Water Temperature	1	
—402	4460339	Terminal, Female	1	
—403	4460342	Connector, Housing	1	
—404	2420131	Sender, Oil Pressure	1	

SECTION 2 GROUND COMPONENTS

# SECTION 2 GROUND COMPONENTS

FIGURE 2-8. DUAL FUEL COMPONENTS INSTALLATION  
FORD ENGINE OPTION.



# SECTION 2 GROUND COMPONENTS

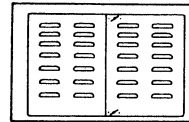
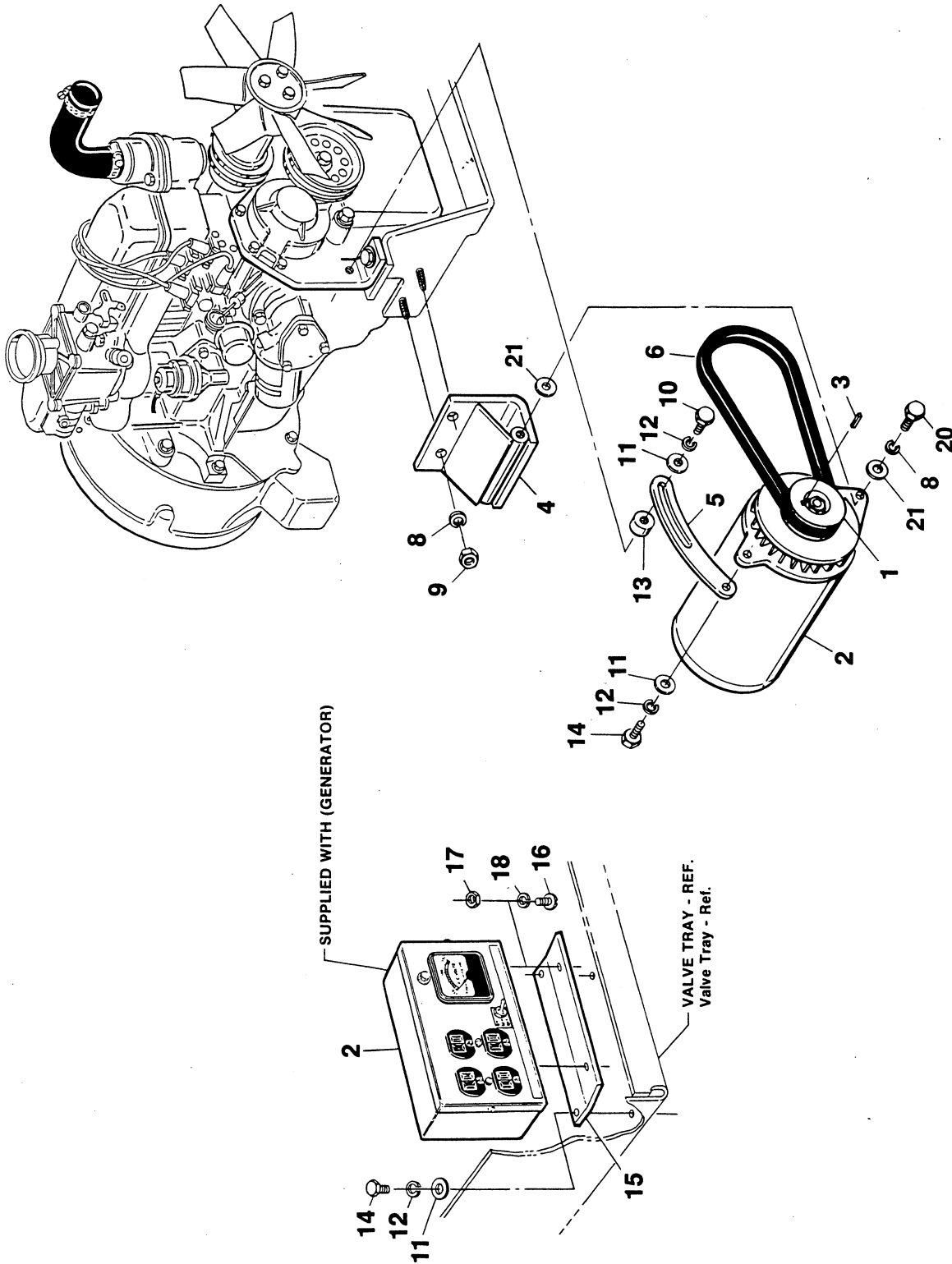
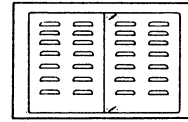

FIGURE & ITEM NO	PART NUMBER	DESCRIPTION	QTY.	REV.
2-8		<b>DUAL FUEL COMPONENTS INSTALLATION FORD ENGINE OPTION</b>	Ref.	
	0250790	<b>DUAL FUEL INSTALLATION</b>	Ref.	C
-1	3720011	Regulator, LPG	1	
-2	2220364	Fitting, Adapter	2	
-3	2180535	Fitting, Barbed	2	
-4	2220648	Fitting, 90°	1	
-5	2120077	Filter-Lock	1	
-6	2220003	Fitting, Swivel	1	
-7	2220675	Fitting, 90°	1	
-8	2720112	Hose, LP	24 in./61m	
-9	2720042	Hose, Heater	28 in./71m	
-10	2720118	Hose, LP (48 in./1.22m Length)	1	
-11	1320032	Clamp	6	
-12	2180104	Fitting, Nipple	1	
-13	2180360	Fitting, Tee	1	
-14	4360188	Switch, Vacuum	1	
-15	2180536	Fitting, Barbed	1	
-16	2180623	Fitting, Tee	1	
-17	0641405	Bolt 1/4"-20NC x 5/8"	2	
-18	4761400	Lockwasher 1/4"	2	
-19	2180387	Fitting, Tank Connector	1	
-20	Not Used			
-21	0901778	Bracket	1	
-22	Not Used			
-23	0080167	Adapter, Air Intake	1	
-24	0080092	Adapter, Carburetor	1	
-25	3840979	Rod	1	
-26	1320126	Bracket, LP Tank	2	
-27	1700818	Decal - Liquid LPG	1	
-28	Not Used			
-29	Not Used			
-30	1320127	Clamp, LP Tank	2	
-31	4640391	Valve, Gasoline	1	
-32	1320095	Clamp, Support	1	
-33	2220805	Fitting, Straight	2	
-34	1320022	Clamp	2	
-35	2220290	Fitting, Tee	1	
-36	2180389	Fitting, Pressure Relief	1	
-37	4400040	Tank, LP	2	

SECTION 2 GROUND COMPONENTS

# SECTION 2 GROUND COMPONENTS

FIGURE 2-9. 110 VOLT GENERATOR INSTALLATION  
(FORD) (OPTIONAL).





# SECTION 2 GROUND COMPONENTS

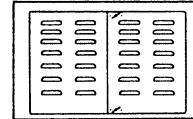
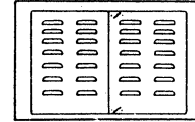

FIGURE & ITEM NO	PART NUMBER	DESCRIPTION	QTY.	REV.
2-9	0250444	110 VOLT GENERATOR INSTALLATION (FORD) (OPTIONAL)	Ref.	B
-1	3580134	Pulley	1	
-2	2460011	Generator and Control Box Assembly	1	
	7012558	Generator	1	
	7003657	Box, Control	1	
	7010699	Voltmeter	1	
-3	2860012	Keystock	1	
-4	0901650	Bracket, Generator Mounting	1	
-5	4340569	Support, Adjustable	1	
-6	0480057	V-Belt	1	
-7	Not Used			
-8	4761600	Lockwasher 3/8"	4	
-9	3311601	Nut 3/8" - 16NC	2	
-10	0641511	Bolt 5/16"-18NC x 1 3/8"	1	
-11	4751500	Flatwasher 5/16"	2	
-12	4761500	Lockwasher 5/16"	2	
-13	0961247	Bushing	1	
-14	0641507	Bolt 5/16"-18NC	1	
-15	0901609	Bracket, Box Mounting	1	
-16	3911004	Screw, Machine #10-24NC x 1/2"	2	
-17	3311001	Nut #10-24NC	2	
-18	4761000	Lockwasher #10	2	
-19	Not Used			
-20	0681610	Bolt 3/8"-16NC x 1 1/4" (Grade 8)	2	
-21	4751600	Flatwasher 3/8"	2	

SECTION 2 GROUND COMPONENTS

# SECTION 2 GROUND COMPONENTS

FIGURE 2-10. ENGINE INSTALLATION - DEUTZ F2L1011.



SECTION 2 GROUND COMPONENTS

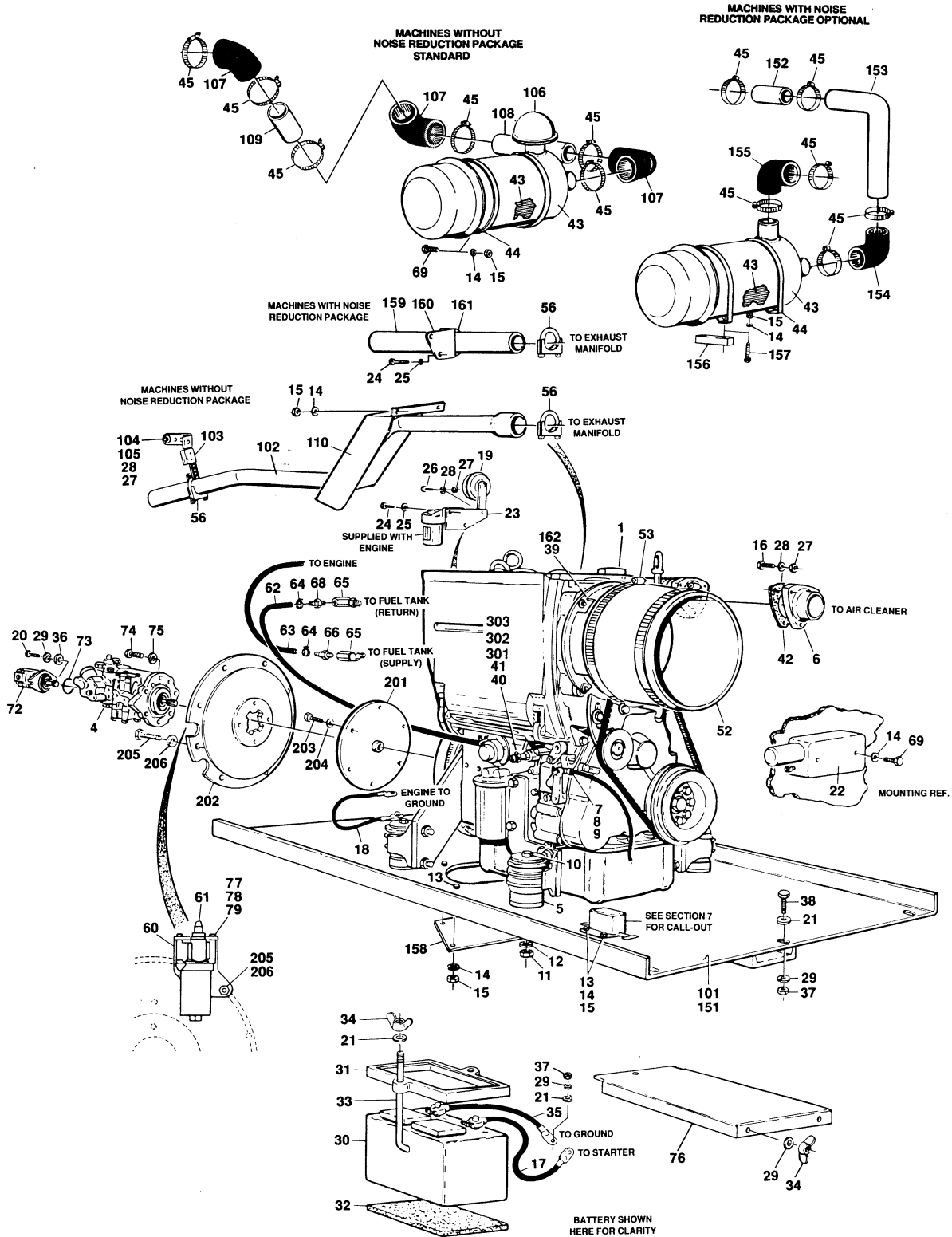

# SECTION 2 GROUND COMPONENTS

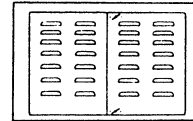
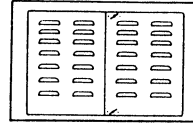

FIGURE & ITEM NO	PART NUMBER	DESCRIPTION	QTY.	REV.
2-10		<b>ENGINE INSTALLATION - DEUTZ F2L1011</b>	Ref.	
		<b>ENGINE INSTALLATION - DEUTZ F2L1011 (STANDARD PARTS)</b>	Ref.	
-1	2000106	Engine - Deutz F2L1011	1	
-2	Not Used			
-3	Not Used			
-4	3600164	Pump Assembly - Sunstrand (See Figure 2-12 for Breakdown)	1	
-5	0361817	Spacer, Engine Mounting	4	
-6	0080177	Adapter, Air Intake	1	
-7	0080172	Adapter, Throttle	1	
-8	3450202	Pin, Cotter 1/16" x 1/2"	1	
-9	3951003	Setscrew #10-24NC x 3/8"	1	
-10	0641840	Bolt 1/2"-13NC x 5"	4	
-11	3311805	Locknut 1/2"-13NC	4	
-12	4751800	Flatwasher 1/2"	4	
-13	0641408	Bolt 1/4"-20NC x 1"	A/R	
-14	4761400	Lockwasher 1/4"	A/R	
-15	3311401	Nut 1/4"-20NC	A/R	
-16	0641512	Bolt	3	
-17	1060406	Cable, Battery	1	
-18	1060093	Cable, Battery	1	
-19	0140001	Horn	1	
-20	0641610	Bolt 3/8"-16NC x 1 1/4"	2	
-21	4751600	Flatwasher 3/8"	16	
-22	0060023	Actuator, Throttle	1	
-23	0901817	Bracket, Fuel Filter	1	
-24	0701010	Bolt, Metric M10 x 20mm	A/R	
-25	4832000	Lockwasher 10m	A/R	
-26	0641508	Bolt 5/16"-18NC x 1"	2	
-27	3311501	Nut 5/16"-18NC	A/R	
-28	4761500	Lockwasher 5/16"	A/R	
-29	4751600	Lockwasher 3/8"	A/R	
-30	0400003	Battery	1	
-31	0400002	Tie-Down, Battery	1	
-32	3980003	Seat, Battery	1	
-33	0630370	Rod, Tie-Down	2	
-34	3300029	Wingnut 3/8"-16NC	2	
-35	1060360	Cable, Battery	1	
-36	4740195	Washer, Hardened	2	
-37	3311601	Nut 3/8"-16NC	6	
-38	0641612	Bolt 3/8"-16NC x 1 1/2"	6	
-39	4843513	Air Intake Weldment	1	
-40	2180730	Fitting, Adapter	1	
-41	2420110	Sender, Oil Pressure	1	
-42	3960407	Gasket	1	
-43	1340020	Air Cleaner Assembly	1	
	7003655	Element, Air Cleaner	1	
-44	0340002	Band, Mounting - Air Cleaner	2	

SECTION 2 GROUND COMPONENTS

# SECTION 2 GROUND COMPONENTS



SECTION 2 GROUND COMPONENTS

FIGURE & ITEM NO	PART NUMBER	DESCRIPTION	QTY.	REV.
2-10		<b>ENGINE INSTALLATION - DEUTZ F2L1011 (CONTINUED)</b>	Ref.	
-45	1320180	Clamp, Hose	6	
-46	Not Used			
-47	Not Used			
-48	Not Used			
-49	Not Used			
-50	Not Used			
-51	Not Used			
-52	2720342	Hose, Air Intake	9 in./23cm	
-53	1320059	Clamp, Hose	3	
-54	Not Used			
-55	Not Used			
-56	1320019	U-Clamp	A/R	
-57	Not Used			
-58	Not Used			
-59	Not Used			
-60	0901778	Bracket, Charge Filter	1	
-61	2120135	Filter, Charge Pressure	1	
	2120136	Element, Charge Filter	1	
-62	2720271	Line, Fuel (Return)	8 ft./2.44m	
-63	2720058	Line, Fuel (Supply)	6 ft./1.83m	
-64	1320022	Clamp, Hose	4	
-65	2200462	Fitting, 90°	2	
-66	2180348	Fitting, Barbed	1	
-67	Not Used			
-68	2180666	Fitting, Barbed	1	
-69	0641406	Bolt 1/4"-20NC x 3/4"	A/R	
-70	Not Used			
-71	Not Used			
-72	3600188	Gear Pump Assembly	1	
	2900660	Seal Kit (Shaft Seals Only)	1	
-73	3790152	O-Ring	1	
-74	0641810	Bolt 1/2"-13NC x 1 1/4"	2	
-75	4761800	Lockwasher 1/2"	2	
-76	1670621	Cover, Battery	1	
-77	0721008	Bolt #10-24NC x 1"	2	
-78	4761000	Lockwasher #10	2	
-79	4751000	Flatwasher #10	2	
	0100043	----- Sealant, Pipe	A/R	
	1281734	<b>ENGINE INSTALLATION - DEUTZ F2L1011 (STANDARD) (VARIABLE PARTS)</b>	Ref.	A
-101	4843437	Tray, Engine Mounting	1	
-102	4564934	Tailpipe	1	
-103	0901387	Bracket, Exhaust Hanger	1	
-104	4300038	Stud (Welded on Part)	4	

# SECTION 2 GROUND COMPONENTS

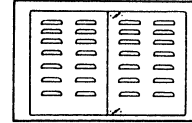

SECTION 2 GROUND COMPONENTS

FIGURE & ITEM NO	PART NUMBER	DESCRIPTION	QTY.	REV.
2-10		<b>ENGINE INSTALLATION - DEUTZ F2L1011 (CONTINUED)</b>	Ref.	
-105	4751500	Flatwasher 5/16"	5	
-106	1120161	Cap, Air Inlet	1	
-107	0080039	Elbow, Air Intake	3	
-108	4564475	Tube, Air Intake	1	
-109	4565571	Tube, Air Intake	1	
-110	4060736	Shield, Exhaust	1	
	1281739	<b>ENGINE INSTALLATION - DEUTZ F2L1011 (WITH NOISE REDUCTION PACKAGE (OPTIONAL) (VARIABLE PARTS)</b>	Ref.	A
-151	4843934	Tray, Engine Mounting	1	
-152	2720351	Hose, Rubber	3 in./7.6cm	
-153	4565347	Tube, Air Intake	1	
-154	0080039	Elbow, Air Intake	1	
-155	0080046	Elbow, Air Intake	1	
-156	0362043	Bar, Spacer	2	
-157	0641420	Bolt 1/4"-20NC x 2 1/2"	4	
-158	3535551	Plate, Cover	1	
-159	4565348	Tail Pipe	1	
-160	0901705	Bracket, Exhaust	1	
-161	1320176	Clamp, Muffler	1	
-162	4280280	Strip, Air Intake	1	
	0250597	<b>PUMP COUPLING INSTALLATION</b>	Ref.	—
-201	1660184	Coupling (Hayes) <b>Note: Coupling Spine must be greased with lithium soap based grease prior to installation.</b>	1	
-202	0080163	Adapter, Pump Mounting	1	
-203	0700810	Bolt, Metric 8mm x 20mm	6	
-204	4831900	Lockwasher 8mm	6	
-205	0701013	Bolt 10mm x 28mm	8	
-206	4832000	Lockwasher 10mm	8	
	3020021	Grease, Coupling	A/R	
	0251796	<b>SPARK ARRESTOR MUFFLER INSTALLATION (NOT SHOWN) (OPTIONAL)</b>	Ref.	—
	3220036	Muffler, Spark Arrestor	1	
	1320019	U-Clamp	2	
		<b>ENGINE COMPONENT REPLACEMENT PARTS</b>	Ref.	
	7000693	Muffler (Standard)	1	
	7014683	Tune-Up Kit (Includes Fuel Line and Oil Plug Washers, Oil and Fuel Filters, Injector Tip Gasket and Valve Cover Gasket)	1	



# SECTION 2 GROUND COMPONENTS

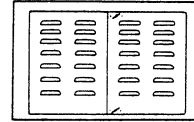
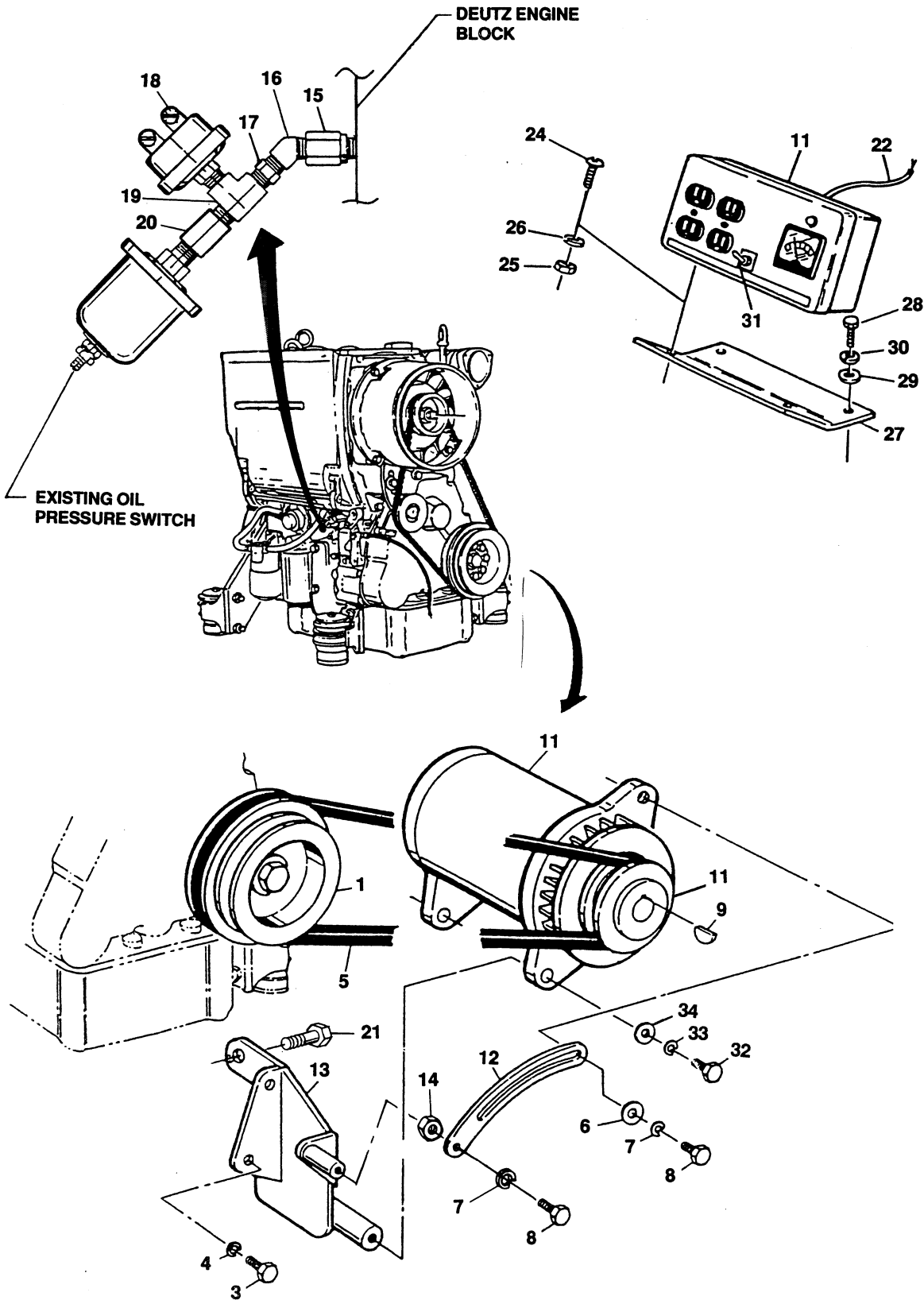
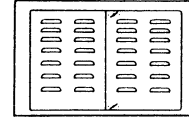

FIGURE & ITEM NO	PART NUMBER	DESCRIPTION	QTY.	REV.
2-11		<b>ENGINE INSTALLATION - DEUTZ F2L1011 (CONTINUED)</b>	Ref.	
	0251548	<b>ENGINE DISTRESS SWITCH INSTALLATION</b>	Ref.	A
—301	4360065	Switch, Pressure	1	
—302	2180360	Fitting, Tee	1	
—303	2180749	Fitting, 45°	1	

SECTION 2 GROUND COMPONENTS

# SECTION 2 GROUND COMPONENTS

FIGURE 2-11. 110 VOLT GENERATOR INSTALLATION (DEUTZ) (OPTIONAL).





# SECTION 2 GROUND COMPONENTS

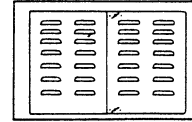

SECTION 2 GROUND COMPONENTS

FIGURE & ITEM NO	PART NUMBER	DESCRIPTION	QTY.	REV.
2—11	0251801	<b>110 VOLT GENERATOR INSTALLATION (DEUTZ) (OPTIONAL)</b>	Ref.	E
—1	3580158	Pulley	1	
—2	Not Used			
—3	0701012	Bolt, Metric 10MM x 25MM	2	
—4	4812000	Flatwasher, Metric 10MM	2	
—5	0480059	V-Belt	1	
—6	4751500	Flatwasher 5/16"	1	
—7	4761500	Lockwasher 5/16"	2	
—8	0681510	Bolt 5/16"-18NC x 1 1/4" (Grade 8)	2	
—9	2860012	Key, Woodruff	1	
—10	3580134	Pulley	1	
—11	2460011	Generator and Control Box Assembly	1	
	7012558	Generator	1	
	7003657	Box, Control	1	
	7010699	Voltmeter	1	
—12	0361815	Arm, Adjustment	1	
—13	4843410	Bracket, Generator Mounting	1	
—14	3311501	Nut 5/16"-18NC	1	
—15	2180730	Fitting, Adapter	1	
—16	2180749	Fitting, 45°	1	
—17	2180537	Fitting, Nipple	1	
—18	4360037	Switch, Pressure	1	
—19	2180360	Fitting, Tee	1	
—20	2200261	Fitting, Coupling	1	
—21	0701414	Bolt, Metric 14MM x 30MM	1	
—22	1060012	Cable, Electrical - 12/4	4 ft./12m	
—23	Not Used			
—24	3911004	Screw, Machine #10-24NC x 1/2"	2	
—25	3311001	Nut #10-24NC	2	
—26	4761000	Lockwasher #10	2	
—27	0901609	Bracket, Control Box Mounting	1	
—28	0641507	Bolt 5/16"-18NC x 7/8"	2	
—29	4751500	Flatwasher 5/16"	2	
—30	4761500	Lockwasher 5/16"	2	
—31	3251476	Nametag - On/Off	1	
—32	0681610	Bolt 3/8"-16NC x 1 1/4" (Grade 8)	2	
—33	4761600	Lockwasher 3/8"	2	
—34	4751600	Flatwasher 3/8"	2	
	0100011	Loctite #242	A/R	

# SECTION 2 GROUND COMPONENTS

FIGURE 2-12. PUMP ASSEMBLY - SUNSTRAND  
(GAS AND DIESEL MACHINES).

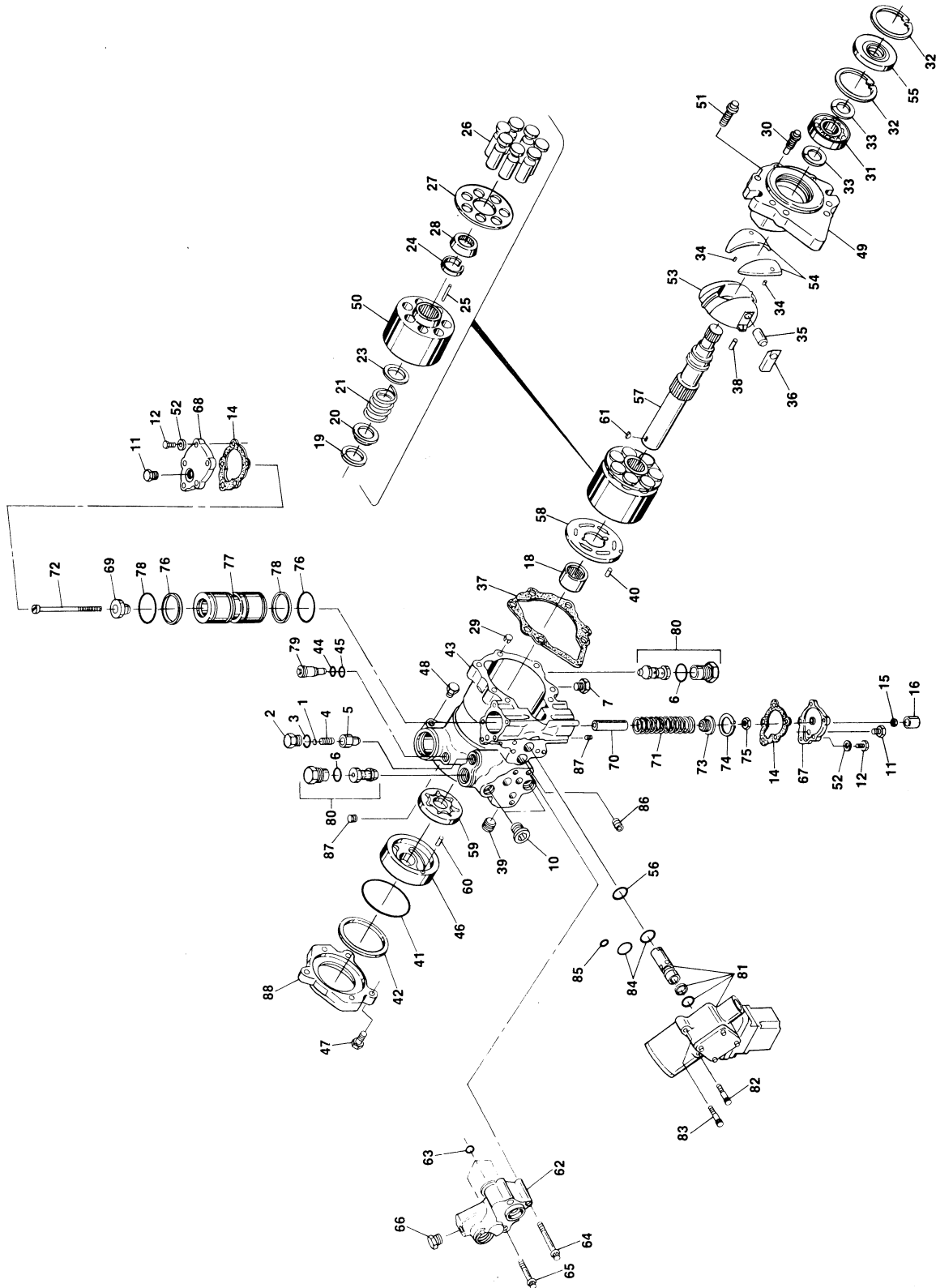
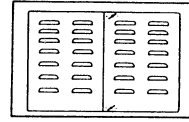

# SECTION 2 GROUND COMPONENTS

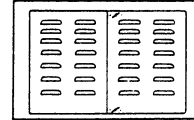
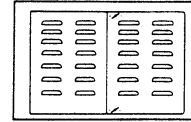

FIGURE & ITEM NO	PART NUMBER	DESCRIPTION	QTY.	REV.
2-12	3600164	<b>PUMP ASSEMBLY - SUNSTRAND</b>	Ref.	A
-1	7007413	Shim Kit - Relief Valve	1	
-2	7007414	Plug	1	
-3	Kit	O-Ring	1	
-4	7007416	Spring, Relief Valve	1	
-5	7007417	Valve, Relief	1	
-6	Kit	O-Ring	2	
-7	7007419	Plug	2	
-8	Not Used			
-9	Not Used			
-10	7007420	Plug	2	
-11	7007208	Plug	2	
-12	7007421	Screw	10	
-13	Not Used			
-14	Kit	Gasket, Servo Cover	2	
-15	7007423	Nut, Special	1	
-16	7007424	Cover, Adjustment	1	
-17	Not Used			
-18	7007425	Bearing, Needle	1	
-19	Kit	Ring, Retaining	1	
-20	Kit	Washer	1	
-21	Kit	Spring	1	
-22	Not Used			
-23	Kit	Washer	1	
-24	Kit	Retainer	1	
-25	Kit	Pin, Slipper Holddown	3	
-26	Kit	Piston Assembly	7	
-27	Kit	Guide, Slipper	1	
-28	Kit	Guide, Retainer	1	
-29	7007435	Pin, Spring	1	
-30	7007436	Screw - 12 Point Head	1	
-31	7007437	Bearing, Ball	1	
-32	7007438	Ring	2	
-33	7007439	Ring	2	
-34	7007440	Pin, Spring	2	
-35	7007441	Handle, Pin	1	
-36	7007442	Sleeve, Bearing	1	
-37	Kit	Gasket, Front Cover	1	
-38	7007444	Pin	1	
-39	7007445	Plug, Expansion	1	
-40	Kit	Pin	1	
-41	Kit	O-Ring	1	
-42	Kit	Ring, Load Temper	1	
-43	7007449	Housing, Pump	1	
-44	Kit	Ring, Back-Up	1	
-45	Kit	O-Ring	1	

SECTION 2 GROUND COMPONENTS

# SECTION 2 GROUND COMPONENTS



SECTION 2 GROUND COMPONENTS

FIGURE & ITEM NO	PART NUMBER	DESCRIPTION	QTY.	REV.
2-12	3600164	<b>PUMP ASSEMBLY - SUNSTRAND (CONTINUED)</b>	Ref.	A
-46	Kit	Cover, Gerotor	1	
-47	7007453	Bolt, Hex	3	
-48	7007208	Plug	1	
-49	7007454	Cover, Front	1	
-50	Kit	Block, Cylinder	1	
-51	7007456	Screw - 12 Point Head	6	
-52	7001438	Washer	10	
-53	Kit	Swashplate	1	
-54	7007458	Journal, Bearing	1	
-55	Kit	Seal, Lip	1	
-56	Kit	O-Ring	1	
-57	7007461	Shaft, Main Pump	1	
-58	Kit	Plate, Valve	1	
-59	Kit	Gerotor Assembly	1	
-60	Kit	Pin	1	
-61	Kit	Key, Woodruff	1	
-62	7007466	Adaptor, Remote Filtration (Without Bypass)	1	
-63	Kit	O-Ring	3	
-64	7007468	Screw	2	
-65	7007469	Screw	2	
-66	7007470	Plug	1	
-67	7007471	Cover, Servo (With Adjuster)	1	
	7007490	Stop, Servo (Not Shown)	2	
	7007491	Nut, Special (Not Shown)	2	
	7007492	Ring, External (Not Shown)	2	
-68	7007482	Cover, Servo (Without Adjuster)	1	
-69	7007483	Guide, Spring	1	
-70	7007484	Stop, Servo	1	
-71	7007485	Spring	1	
-72	7007486	Screw	1	
-73	7007487	Guide, Spring	1	
-74	7007488	Ring, Retaining	1	
-75	7007489	Locknut	1	
-76	Kit	Ring, Piston	2	
-77	7007494	Piston, Servo	1	
-78	Kit	O-Ring	2	
-79	7007472	Valve, By-Pass	1	
-80	7007473	Valve, Pressure Release (Includes Item 6)	2	
-81	7007474	Control, Dual Oil-Filled	1	
	7007496	Coil Assembly (Pilot)	1	
	7007497	Plug (Pump)	1	
	7007498	Plug (Valve Harness)	1	
-82	7007478	Screw	2	
-83	7001498	Screw	2	
-84	Kit	O-Ring	2	
-85	Kit	O-Ring	1	
-86	7007475	Plug, Orifice/Screen - .156	1	

# SECTION 2 GROUND COMPONENTS

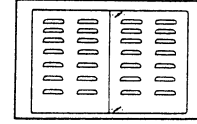
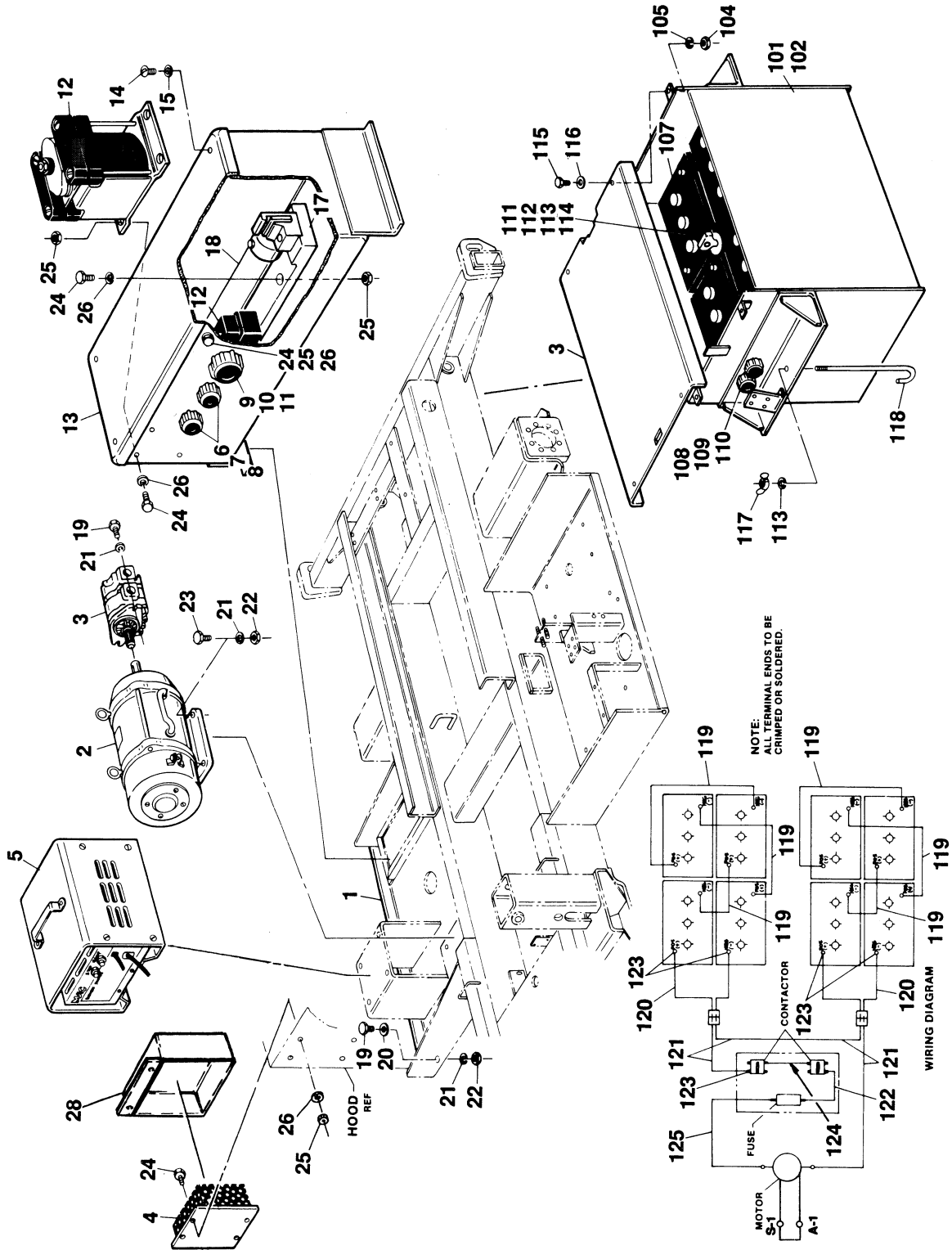
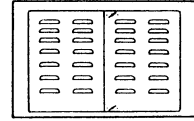

FIGURE & ITEM NO	PART NUMBER	DESCRIPTION	QTY.	REV.
2—12	3600164	<b>PUMP ASSEMBLY - SUNSTRAND (CONTINUED)</b>	Ref.	A
—87	7007477	Plug, Orifice - .37	2	
—88	7007476	Adapter, Auxiliary Pump	1	
	2900752	Seal Kit - Complete (Includes Items 3,6,14,37,41,42,44, 45,55,56,63,76,78,84 and 85)	1	
	7007412	Seal Kit - Servo Piston (Includes Items 76 and 78)	1	
	2900826	Charge Pump Kit (Includes Items 41,42,46,59,60,61)	1	
	2900827	Cylinder Block Kit (Includes Items 19-28, 40,50,53,55,58)	1	

SECTION 2 GROUND COMPONENTS

# SECTION 2 GROUND COMPONENTS

FIGURE 2-13. ELECTRICAL COMPONENTS INSTALLATION (ELECTRIC MACHINES ONLY).



# SECTION 2 GROUND COMPONENTS

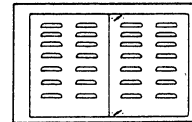

SECTION 2 GROUND COMPONENTS

FIGURE & ITEM NO	PART NUMBER	DESCRIPTION	QTY.	REV.
2-13		<b>ELECTRICAL COMPONENTS INSTALLATION (ELECTRIC MACHINES ONLY)</b>	Ref.	
	0251302	<b>ELECTRIC MOTOR, PUMP AND CHARGER INSTALLATION</b>	Ref.	A
-1	4843550	Tray Weldment	1	
-2	3160153	Electric Motor Assembly	1	
	7012567	Brush	8	
	7012568	Spring	8	
-3	3600170	Pump Assembly	1	
	2900660	Seal Kit - Pump Shaft	1	
-4	1600122	Convertor	1	
-5	0400088	Battery Charger Assembly (See Figure 2-14 for Breakdown)	1	
-6	4460051	Connector, Strain Relief - 3/4"	2	
-7	0960238	Bushing - 3/4"	2	
-8	3300048	Locknut, Conduit - 3/4"	2	
-9	4460052	Connector, Strain Relief - 1/2"	2	
-10	0960239	Bushing - 1/2"	2	
-11	3300047	Locknut, Conduit - 1/2"	2	
-12	3740064	Relay	2	
-13	1670511	Cover, Box	1	
-14	3911012	Screw, Machine #10-24NC x 3/4"	4	
-15	4740120	Washer, Neoprene	4	
-16	3740049	Relay	1	
-17	2400027	Fuseholder - 200 Amp	1	
-18	2400025	Fuse - 200 Amp	1	
-19	0641610	Bolt 3/8"-16NC x 1 1/4"	8	
-20	4751600	Flatwasher 3/8"	12	
-21	4761600	Lockwasher 3/8"	12	
-22	3311601	Nut 3/8"-16NC	10	
-23	0641614	Bolt 3/8"-16NC x 1 3/4"	4	
-24	0641408	Bolt 1/4"-20NC x 1"	19	
-25	3311401	Nut 1/4"-20NC	19	
-26	4761400	Lockwasher 1/4"	19	
-27	Not Used			
-28	0860726	Cover, Box	1	
	0251754	<b>BATTERIES INSTALLATION</b>	Ref.	A
-101	4843519	Battery Box Weldment (Right Side)	1	
-102	4843557	Battery Box Weldment (Left Side)	1	
-103	1670550	Cover, Battery Box	2	
-104	3311401	Nut 1/4"-20NC	12	
-105	4761400	Lockwasher 1/4"	12	
-106	0641412	Bolt 1/4"-20NC x 1 1/2"	4	
-107	0400055	Battery	8	





# SECTION 2 GROUND COMPONENTS

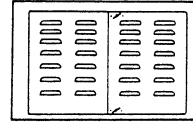
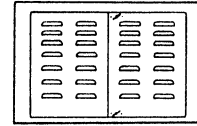

FIGURE & ITEM NO	PART NUMBER	DESCRIPTION	QTY.	REV.
2-13		<b>ELECTRICAL COMPONENTS INSTALLATION (ELECTRIC MACHINES ONLY) (CONTINUED)</b>	Ref.	
-108	4460051	Connector, Strain Relief - 3/4"	4	
-109	0960238	Bushing - 3/4"	4	
-110	3300048	Locknut, Conduit - 3/4"	4	
-111	0630428	Bolt, Hold-down	2	
-112	4740273	Washer, Special	2	
-113	4761600	Lockwasher 3/8"	6	
-114	3311601	Nut 3/8"-16NC	2	
-115	0641406	Bolt 1/4"-20NC x 3/4"	8	
-116	4751400	Flatwasher 1/4"	8	
-117	3300029	Wingnut 3/8"-16NC	4	
-118	3841046	Rod, Attaching	4	
-119	1060352	Cable, Battery	6	
-120	1060347	Cable, Battery	2	
-121	1060348	Cable, Battery	1	
-122	1060340	Cable, Battery	1	
-123	4460199	End, Terminal	5	
-124	1060338	Cable, Battery	1	
-125	1060351	Cable, Battery	1	

SECTION 2 GROUND COMPONENTS

# SECTION 2 GROUND COMPONENTS

FIGURE 2-14. BATTERY CHARGER ASSEMBLY  
(ELECTRIC MACHINES ONLY).



SECTION 2  
GROUND COMPONENTS

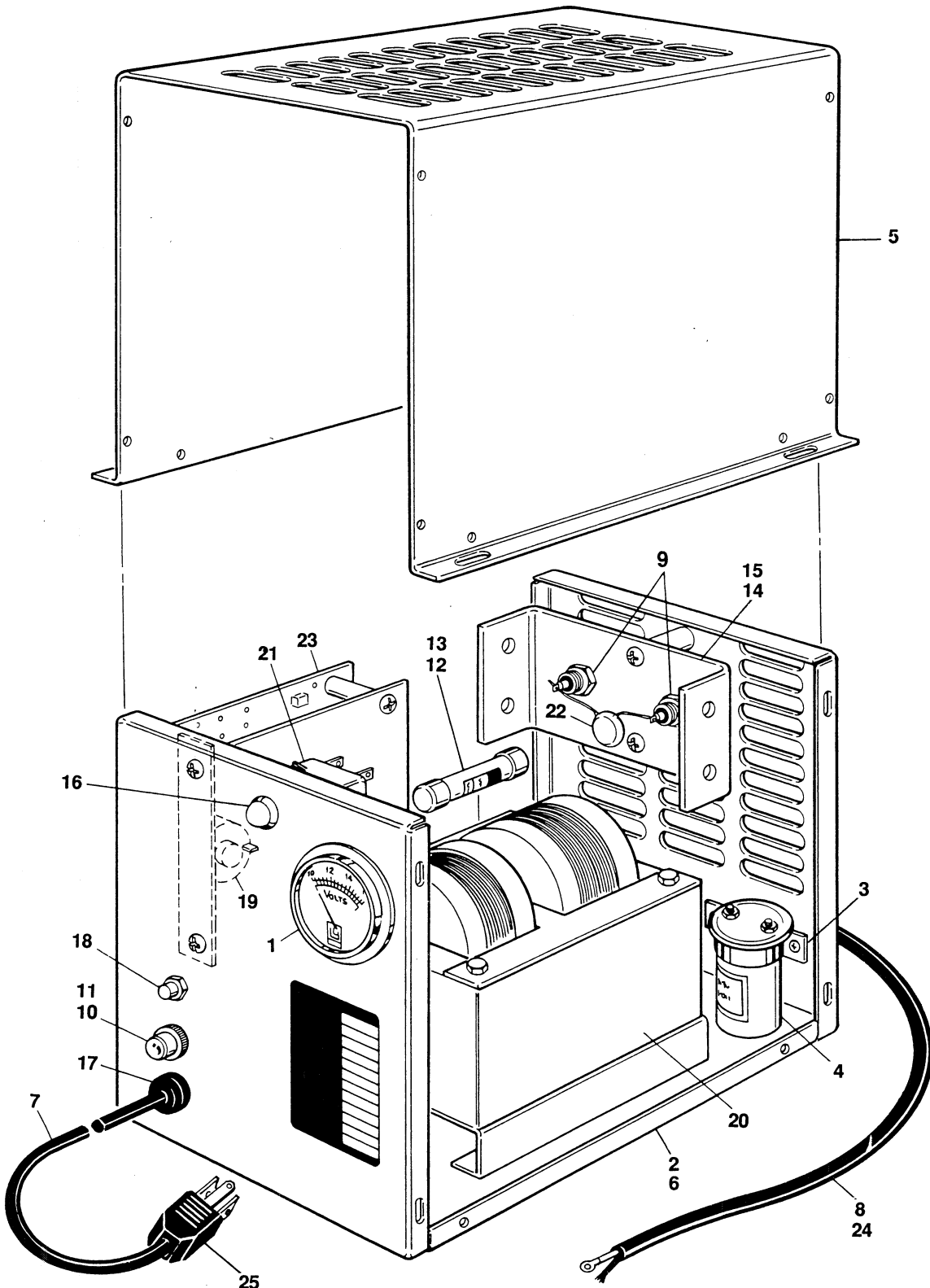

# SECTION 2 GROUND COMPONENTS

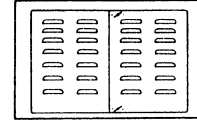

FIGURE & ITEM NO	PART NUMBER	DESCRIPTION	QTY.	REV.
2—14	0400088	<b>BATTERY CHARGER ASSEMBLY (ELECTRIC MACHINES ONLY)</b>	Ref.	—
—1	7011573	Ammeter	1	
—2	Not Available	Case - Complete	1	
—3	7011511	Strap, Capacitor	1	
—4	7011623	Capacitor - 15MFD/440VAC	1	
—5	Not Available	Cover, Case	1	
—6	Not Available	Case, Main	1	
—7	7011575	Cord, AC	1	
—8	7011609	Cord, DC	1	
—9	7011576	Diode - 70 Amp	2	
—10	7011508	Fuse, AC-15Amp	1	
—11	7011507	Fuseholder, AC	1	
—12	7011594	Fuseholder, DC	1	
—13	7011578	Fuse, DC - 30AMP	1	
—14	7011610	Heatsink	1	
—15	7011611	Heatsink Assembly	1	
—16	7011506	Light, Pilot	1	
—17	7011528	Connector, Strain Relief	1	
—18	7011530	Switch, Red Stop	1	
—19	7011517	Triac	1	
—20	7011585	Transformer	1	
—21	7011551	Control, Transformer	1	
—22	7011584	Varistor	1	
—23	7011608	Board, Circuit	1	
—24	7011529	Connector, Strain Relief	1	
—25	Supply Locally	Plug, AC	1	

SECTION 2 GROUND COMPONENTS



# SECTION 2 GROUND COMPONENTS

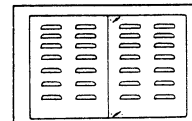
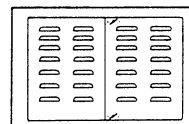

FIGURE & ITEM NO	PART NUMBER	DESCRIPTION	QTY.	REV.
2-15		<b>GROUND CONTROL BOX ASSEMBLY AND INSTALLATION</b>	Ref.	
	1281748	<b>GROUND CONTROL BOX ASSEMBLY (GAS AND DIESEL) (STANDARD PARTS)</b>	Ref.	A
	1281591	<b>GROUND CONTROL BOX ASSEMBLY (ELECTRIC MACHINES) (STANDARD PARTS)</b>	Ref.	A
-1	Not Used			
-2	3252064	Lid, Ground Control Box	1	
-3	4420037	Strip, Rubber	3 ft./9m	
-4	Not Used			
-5	4761400	Lockwasher 1/4"	A/R	
-6	3311401	Nut 1/4"-20NC	A/R	
-7	3640621	Rail, Mounting	1	
-8	4460298	Block, Terminal	21	
-9	4460301	Marker, Terminal	1	
-10	4460299	Stop, Terminal	2	
-11	4460300	Barrier, Terminal	1	
-12	Not Used			
-13	4460305	Screw, Buss Bar	A/R	
-14	4460306	Washer, Buss Bar	A/R	
-15	4460307	Sleeve, Buss Bar	A/R	
-16	Not Used			
-17	4770600	Starwasher #6	2	
-18	3310601	Nut #6-32NC	2	
-19	Not Used			
-20	4751000	Flatwasher #10	A/R	
-21	3311001	Nut #10-24NC	A/R	
-22	4460051	Connector, Strain Relief - 3/4"	3	
-23	4460071	Connector, Strain Relief - 1/2"	1	
-24	3300048	Nut, Conduit - 3/4"	4	
-25	0960238	Bushing - 3/4"	4	
-26	2420009	Hourmeter	1	
-27	Not Used			
-28	3520028	Plug, Hole - 1/2"	A/R	
-29	Not Used			
-30	Not Used			
-31	3790012	O-Ring	A/R	
-32	4360284	Switch, Key (Select)	1	
-33	Not Used			
-34	4360198	Switch, Toggle (Lift)	1	
-35	2600161	Hinge	1	
-36	3911008	Screw, Machine #10-24NC x 1/2"	7	
-37	Not Used			
-38	33000177	Nut, Tinnerman	2	
-39	4740120	Washer Nylon	5	
-40	0750806	Screw, Self-Tapping #3 x 3/4"	2	
-41	Not Used			
-42	Not Used			
-43	Not Used			

SECTION 2 GROUND COMPONENTS

# SECTION 2 GROUND COMPONENTS



SECTION 2 GROUND COMPONENTS

FIGURE & ITEM NO	PART NUMBER	DESCRIPTION	QTY.	REV.
2-15		<b>GROUND CONTROL BOX ASSEMBLY AND INSTALLATION (CONTINUED)</b>	Ref.	
-44	Not Used			
-45	3520026	Plug, Hole - 5/8"	A/R	
-46	Not Used			
-47	Not Used			
-48	4360267	Block, Contact	1	
-49	4360281	Block, Contact	1	
	0860768	<b>GROUND CONTROL BOX ASSEMBLY (DIESEL MACHINES) (VARIABLE PARTS)</b>	Ref.	A
-101	4843375	Box, Ground Control	1	
-102	3252064	Lid, Ground Control	1	
-103	3740049	Relay	10	
-104	4460309	Bar, Buss - 3 Position	1	
-105	4360216	Breaker, Circuit - 30 Amp	1	
-106	4360232	Breaker, Circuit - 15 Amp	1	
-107	2420091	Voltmeter	1	
-108	4360274	Switch, Push Button (Start)	1	
-109	Not Used			
-110	Not Used			
-111	4360199	Switch, Toggle (Emergency Stop)	1	
-112	2420111	Gauge, Oil Pressure	1	
-113	3520070	Plug, Hole	1	
-114	4360212	Breaker, Circuit - 3 Amp	1	
-115	1701683	Decal - Relay Function	1	
	0860767	<b>GROUND CONTROL BOX ASSEMBLY (GAS MACHINES) (VARIABLE PARTS)</b>	Ref.	A
-121	4843375	Box, Ground Control	1	
-122	3252064	Lid, Ground Control	1	
-123	3740049	Relay	9	
-124	4460309	Bar, Buss - 3 Position	1	
-125	4360216	Breaker, Circuit - 30 Amp	1	
-126	4360232	Breaker, Circuit - 15 Amp	1	
-127	2420091	Voltmeter	1	
-128	4360274	Switch, Push Button (Start)	1	
-129	Not Used			
-130	Not Used			
-131	4360199	Switch, Toggle (Emergency Stop)	1	
-132	2420144	Gauge, Oil Pressure	1	
-133	2420143	Gauge, Water Temperature	1	
-134	Not Used			
-135	1701683	Decal - Relay Functions	1	
	0860727	<b>GROUND CONTROL BOX ASSEMBLY (ELECTRIC MACHINES) (VARIABLE PARTS)</b>	Ref.	A
-141	4843902	Box, Ground Control	1	
-142	3252114	Lid, Ground Control	1	

# SECTION 2 GROUND COMPONENTS

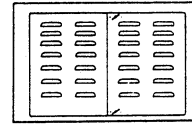

# SECTION 2 GROUND COMPONENTS

FIGURE & ITEM NO	PART NUMBER	DESCRIPTION	QTY.	REV.
2-15		<b>GROUND CONTROL BOX ASSEMBLY AND INSTALLATION (CONTINUED)</b>	Ref.	
-143	3740049	Relay	7	
-144	4460308	Bar, Buss - 2 Position	1	
-145	Not Required			
-146	4360232	Breaker, Circuit - 15 Amp	5	
-147	Not Used			
-148	Not Used			
-149	3520070	Plug, Hole - 2 1/8"	3	
-150	Not Used			
-151	1701537	Decal - Relay Functions	1	
	1281203	<b>GROUND CONTROL BOX INSTALLATION (STANDARD PARTS)</b>	Ref.	H
-201	Not Used			
-202	0641408	Bolt 1/4"-20NC x 1"	2	
-203	4751400	Flatwasher 1/4"	4	
-204	4761400	Lockwasher 1/4"	2	
-205	3311401	Nut 1/4"-20NC	2	
	1281203	<b>GROUND CONTROL BOX INSTALLATION (VARIABLE PARTS)</b>	Ref.	H
-206	0860768	Ground Control Box Assembly (Diesel Machines) (Includes Items 1-115)	1	
	0860767	Ground Control Box Assembly (Gas Machines) (Includes Item 1-48 and 120-135)	1	
	0860727	Ground Control Box Assembly (Electric Machines) (Includes Items 1-48 and 141-151)	1	
	0250790	<b>DUAL FUEL CONTROLS INSTALLATION (OPTIONAL PARTS)</b>	Ref.	C
-301	4360201	Switch, Toggle (Select)	1	
-302	3790012	O-Ring	1	
	1281554	<b>TRAVERSING PLATFORM CONTROLS INSTALLATION (OPTIONAL PARTS)</b>	Ref.	
-401	4360202	Switch, Toggle (Traverse)	1	
-402	3790012	O-Ring	1	

# SECTION 2 GROUND COMPONENTS

FIGURE 2-16. HOODS AND BEACON LIGHT INSTALLATION.

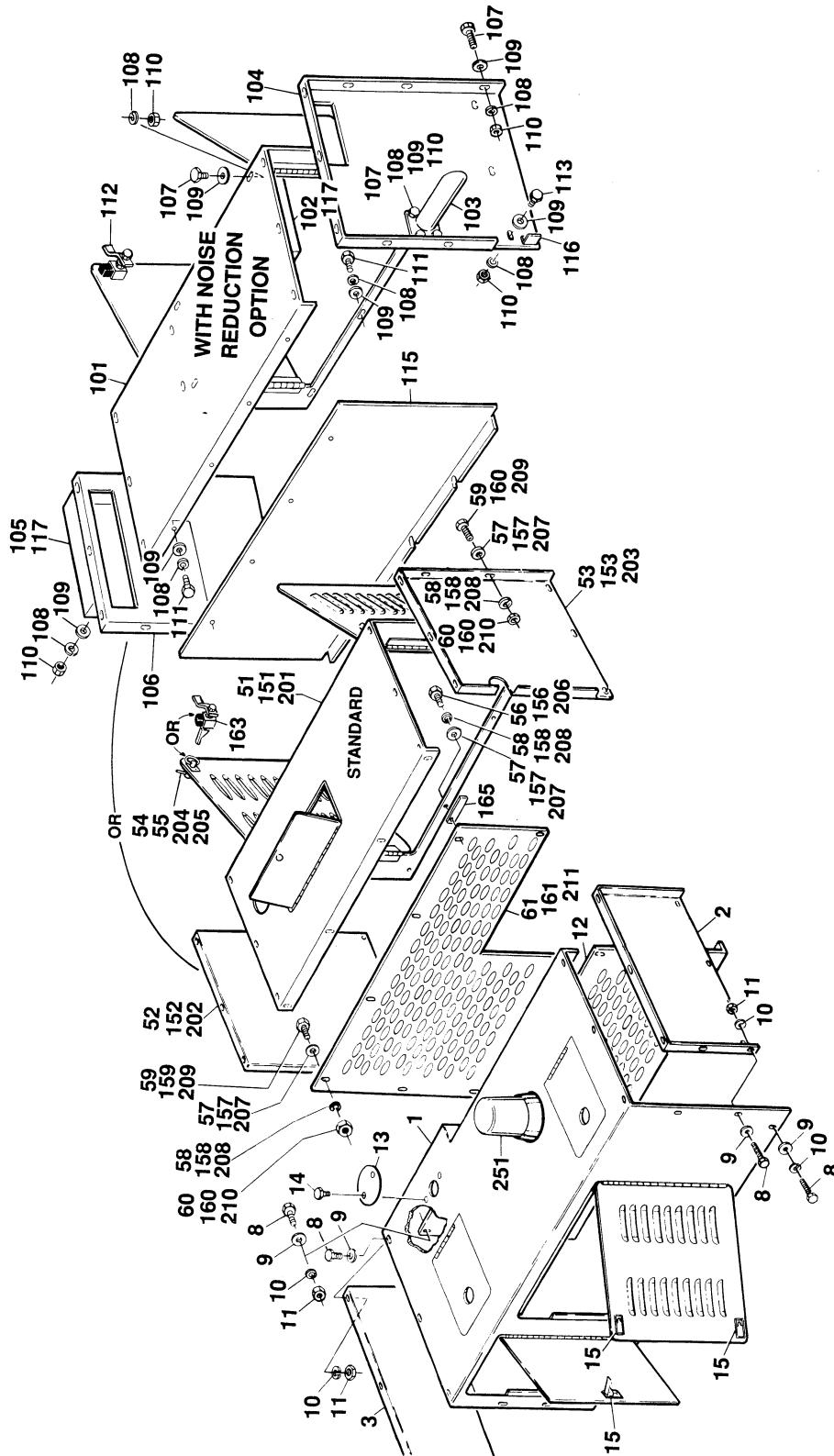
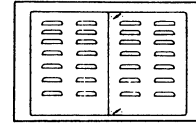



# SECTION 2 GROUND COMPONENTS

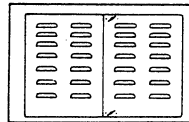

# SECTION 2 GROUND COMPONENTS

FIGURE & ITEM NO	PART NUMBER	DESCRIPTION	QTY.	REV.
2-16		<b>HOODS AND BEACON LIGHT INSTALLATION</b>	Ref.	
	0250687	<b>HOOD INSTALLATION - LEFT SIDE (STANDARD ON ALL MACHINES)</b>	Ref.	B
-1	2680387			
-2	3534073	Hood Weldment - Left Side	1	
-3	3534074	Plate - Left Side Rear	1	
		Plate - Left Side Front	1	
-4	Not Used			
-5	Not Used			
-6	Not Used			
-7	Not Used			
-8	0641406	Bolt 1/4"-20NC x 3/4"	25	
-9	4751400	Flatwasher 1/4"	31	
-10	4761400	Lockwasher 1/4"	25	
-11	3311401	Nut 1/4"-20NC	14	
-12	3534089	Plate - Left Side Inside	1	
-13	1670560	Cover	1	
-14	0751006	Screw, Self-Tapping #10 x 3/4"	2	
-15	2940042	Latch	3	
	0100011	----- Loctite #242	A/R	
	0250247	<b>HOOD INSTALLATION - RIGHT SIDE (DIESEL MACHINES "WITHOUT" NOISE REDUCTION PACKAGE) (STANDARD)</b>	Ref.	C
-51	2680382	Hood Weldment - Right Side	1	
-52	2680381	Plate Weldment - Right Side Front	1	
-53	3533706	Plate Weldment - Right Side Rear	1	
-54	2940048	Latch	2	
-55	3820019	Rivet	4	
-56	0641406	Bolt 1/4"-20NC x 3/4"	10	
-57	4751400	Flatwasher 1/4"	45	
-58	4761400	Lockwasher 1/4"	29	
-59	0641408	Bolt 1/4"-20NC x 1"	19	
-60	3311401	Nut 1/4"-20NC	19	
-61	3534534	Plate - Right Side Inside	1	
	0251978	<b>HOOD INSTALLATION - RIGHT SIDE (DIESEL MACHINES "WITH" NOISE REDUCTION PACKAGE) (OPTIONAL)</b>	Ref.	B
-101	2680396	Hood Weldment - Right Side	1	
-102	3535353	Plate - Air Exhaust	1	
-103	4844024	Snorkel, Exhaust	1	
-104	3535348	Plate - Right Side Rear	1	
-105	3535352	Plate - Air Intake	1	
-106	2680395	Plate - Right Side Front	1	
-107	0641406	Bolt 1/4"-20NC x 3/4"	30	
-108	4761400	Lockwasher 1/4"	53	
-109	4751400	Flatwasher 1/4"	93	
-110	3311401	Nut 1/4"-20NC	42	

SECTION 2 GROUND COMPONENTS

**SECTION 2 GROUND COMPONENTS**

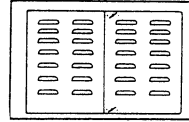
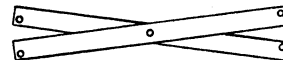

FIGURE & ITEM NO	PART NUMBER	DESCRIPTION	QTY.	REV.
2-16		<b>HOODS AND BEACON LIGHT INSTALLATION (CONTINUED)</b>	Ref.	
-111	3941406	Screw, Self-Tapping 1/4" x 3/4"	11	
-112	2940042	Latch, Flush Mounting	2	
-113	0641408	Bolt 1/4"-20NC x 1"	6	
-114	Not Used			
-115	3535350	Plate - Right Side Inside	1	
-116	0181637	Angle	2	
-117	2820047	Foam, Acoustical	2	
	0100011	----- Loctite #242	A/R	
	0250241	<b>HOOD INSTALLATION - RIGHT SIDE (GAS MACHINES)</b>	Ref.	D
-151	2680379	Hood Weldment - Right Side	1	
-152	3533705	Plate - Right Side Front	1	
-153	3533706	Plate - Right Side Rear	1	
-154	Not Used			
-155	Not Used			
-156	0641406	Bolt 1/4"-20NC x 3/4"	3	
-157	4751400	Flatwasher 1/4"	47	
-158	4761400	Lockwasher 1/4"	29	
-159	0641410	Bolt 1/4"-20NC x 1 1/8"	25	
-160	3311401	Nut 1/4"-20NC	25	
-161	3534197	Plate - Right Side Inside	1	
-162	Not Used			
-163	2940042	Latch, Flush Mount	2	
-164	Not Used			
-165	0362100	Bar	1	
	0100011	----- Loctite #242	A/R	
	0250540	<b>HOOD INSTALLATION - RIGHT SIDE (ELECTRIC MACHINES)</b>	Ref.	—
-201	2680385	Hood Weldment - Right Side	1	
-202	3534058	Plate - Right Side Front	1	
-203	3534059	Plate - Right Side Rear	1	
-204	2940048	Latch	2	
-205	3820019	Rivet	4	
-206	0641406	Bolt 1/4"-20NC x 3/4"	4	
-207	4751400	Flatwasher 1/4"	56	
-208	4761400	Lockwasher 1/4"	30	
-209	0641408	Bolt 1/4"-20NC x 1"	26	
-210	3311401	Nut 1/4"-20NC	26	
-211	3534064	Plate - Right Side Inside	1	
	0252266	<b>ROTATING BEACON LIGHT INSTALLATION (HOOD MOUNTED) (OPTION)</b>	Ref.	—
-251	2920018	Light, Beacon - Amber	1	

# SECTION 3 SIZZOR ARMS



## TABLE OF CONTENTS

FIGURE NO.	DESCRIPTION	PAGE NO.
3-1	Sizzors Arms Installation - CM40RT .....	3-2
3-2	Sizzors Arms Installation - CM33RT .....	3-6
3-3	Sizzors Arms Installation - CM25RT .....	3-10
3-4	Sizzors Arms Guard Installation .....	3-14

SECTION 3 SIZZOR ARMS

# SECTION 3 SIZZOR ARMS

FIGURE 3-1. SIZZORS ARMS INSTALLATIONS - CM40RT.

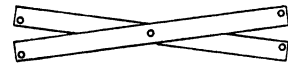

SECTION 3  
SIZZOR  
ARMS

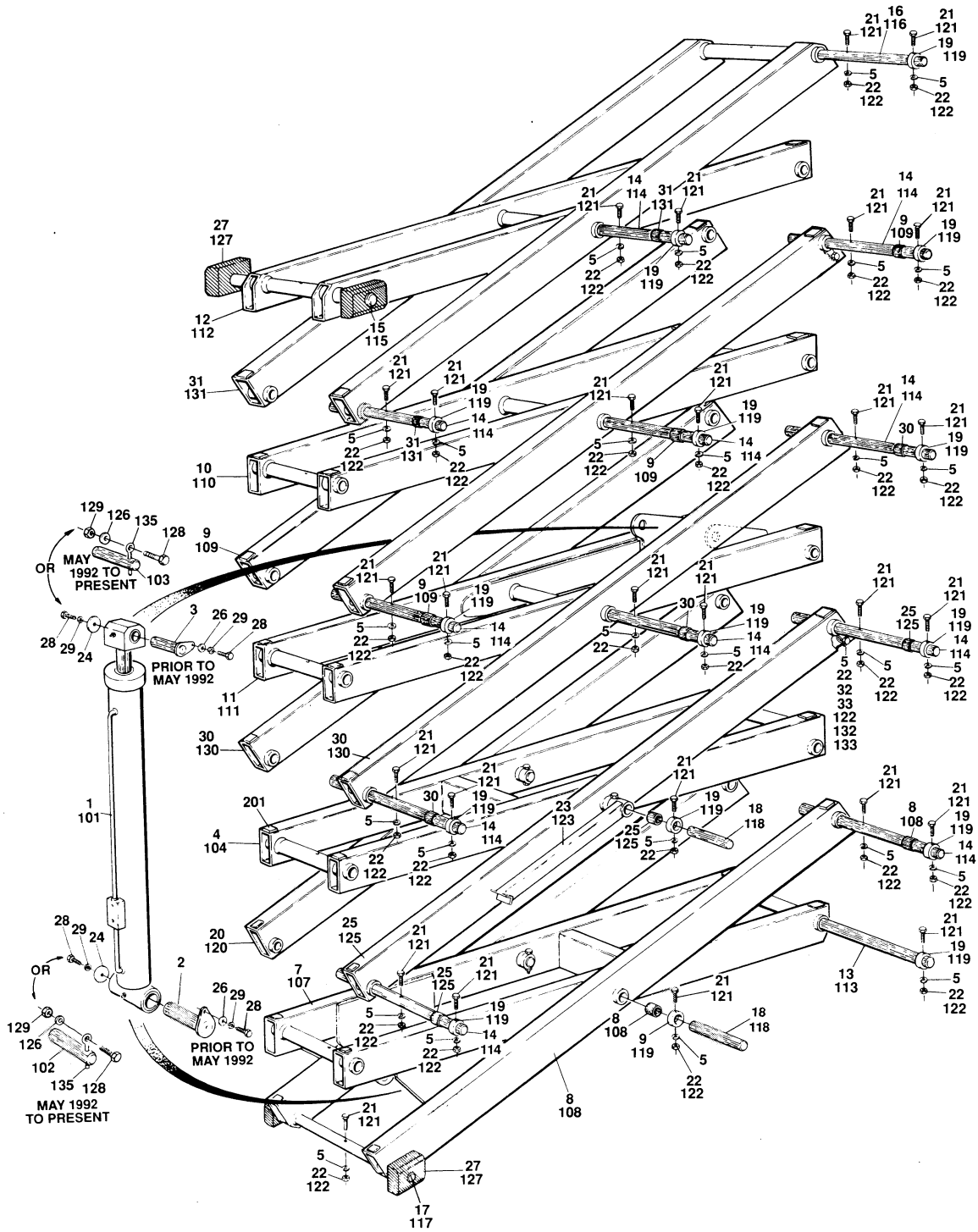

# SECTION 3 SIZZOR ARMS

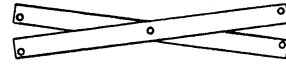

## TABLE OF CONTENTS

FIGURE NO.	DESCRIPTION	PAGE NO.
3-1	Sizzors Arms Installation - CM40RT .....	3-2
3-2	Sizzors Arms Installation - CM33RT .....	3-6
3-3	Sizzors Arms Installation - CM25RT .....	3-10
3-4	Sizzors Arms Guard Installation .....	3-14

**S  
E  
C  
T  
I  
O  
N  
3  
S  
I  
Z  
Z  
O  
R  
A  
R  
M  
S**

# SECTION 3 SIZZOR ARMS

FIGURE 3-1. SIZZORS ARMS INSTALLATIONS - CM40RT.

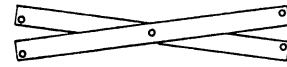

SECTION 3  
SIZZOR  
ARMS

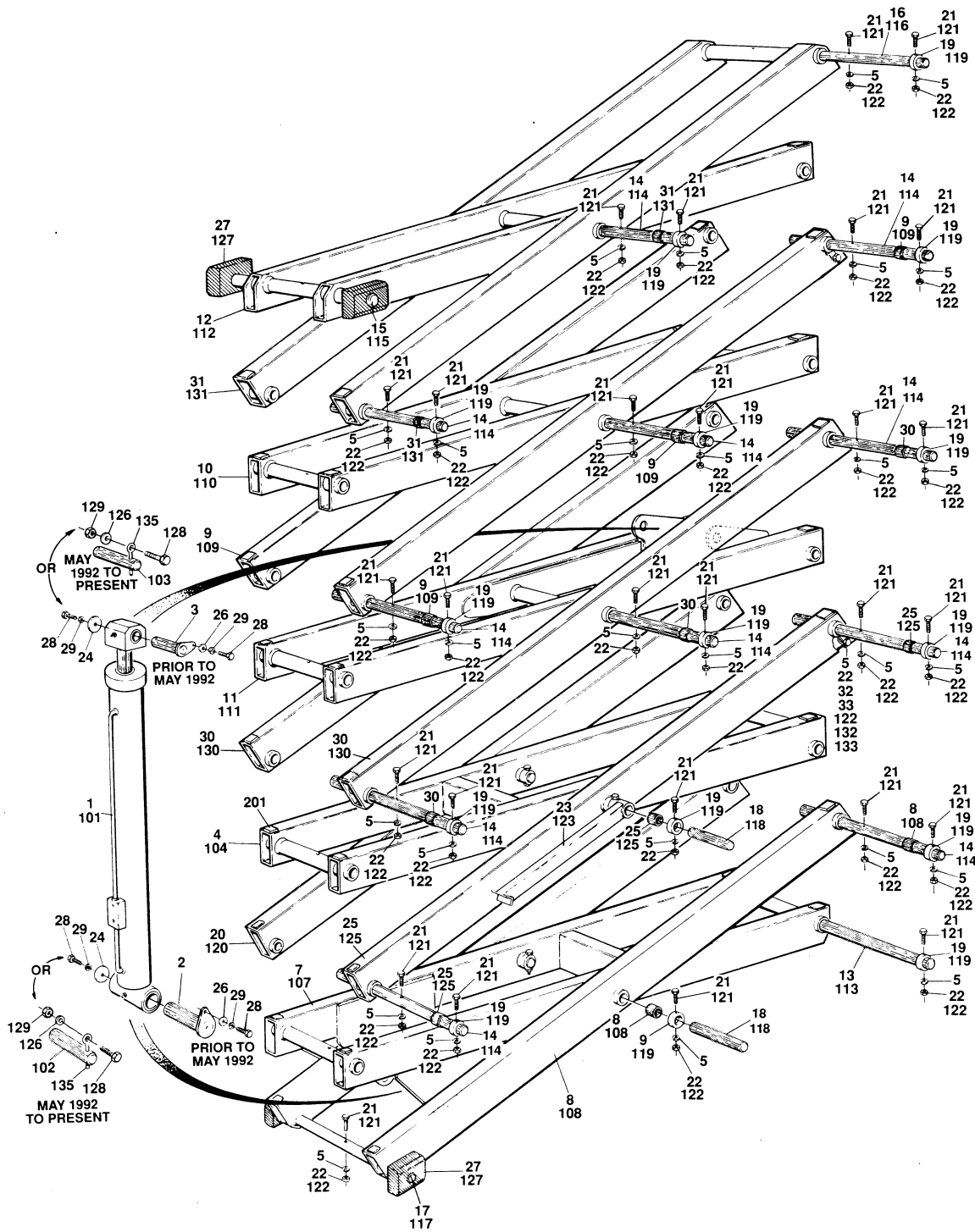

# SECTION 3 SIZZOR ARMS

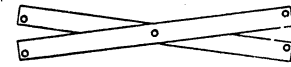

FIGURE & ITEM NO	PART NUMBER	DESCRIPTION	QTY.	REV.
3-1		<b>SIZZOR ARMS INSTALLATIONS - CM40RT</b>	Ref.	
	1281680	<b>SIZZOR ARMS INSTALLATIONS (MACHINES BUILT PRIOR TO MAY 1992) (STANDARD PARTS)</b>	Ref.	B
-1	1682243	Lift Cylinder Assembly (See Section 5 for Breakdown)	1	
-2	3421645	Pin, Attach (Bottom Lift Cylinder)	1	
-3	3421647	Pin, Attach (Top Lift Cylinder)	1	
-4	0200406	Arm Weldment (2nd Inboard)	1	
-5	4761500	Lockwasher 5/16"	51	
-6	Not Used			
-7	0200366	Arm Weldment (Bottom Inboard)	1	
-8	0200451	Arm Weldment (Bottom Outboard)	1	
	0961664	Bushing, Composite	4	
-9	0200452	Arm Weldment (4th Outboard)	2	
	0961664	Bushing, Composite (3 Per Arm)	6	
-10	0200415	Arm Weldment (4th Inboard)	1	
-11	0200405	Arm Weldment (3rd Inboard)	1	
-12	0200407	Arm Weldment (Top Inboard)	1	
-13	3421637	Pin, Attach	1	
-14	3421638	Pin, Attach	11	
-15	3421639	Pin, Attach	1	
-16	3421640	Pin, Attach	1	
-17	3421641	Pin, Attach	1	
-18	3421642	Pin, Attach	4	
-19	1440227	Collar	32	
-20	0200403	Arm Weldment (2nd Outboard - Left Side)	1	
	0961664	Bushing, Composite (Not Shown)	3	
-21	0641528	Bolt 5/16"-18NC x 3 1/2"	47	
-22	3311501	Nut 5/16"-18NC	51	
-23	4843248	Prop, Safety	2	
-24	4740303	Washer, Special	2	
-25	0200402	Arm Weldment (2nd Outboard - Right Side)	1	
	0961664	Bushing, Composite	3	
-26	4751800	Flatwasher 1/2"	2	
-27	3340579	Pad, Sliding	4	
-28	0641808	Bolt 1/2"-13NC x 1"	4	
-29	4761800	Lockwasher 1/2"	4	
-30	0200404	Arm Weldment (3rd Outboard)	2	
	0961664	Bushing, Composite (3 Per Arm)	6	
-31	0200453	Arm Weldment (Top Outboard)	1	
	0961664	Bushing, Composite	4	
-32	1320061	Clamp, Hose	4	
-33	0641508	Bolt 5/16"-18NC x 1"	4	
	3020028	Lube, Graphokote	A/R	

SECTION 3 SIZZOR ARMS





# SECTION 3 SIZZOR ARMS

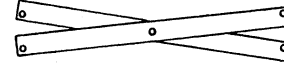

FIGURE & ITEM NO	PART NUMBER	DESCRIPTION	QTY.	REV.
3-1		<b>SIZZOR ARMS INSTALLATIONS - CM40RT (CONTINUED)</b>	Ref.	
	1281824	<b>SIZZOR ARMS INSTALLATION (MACHINES BUILT MAY 1992 TO PRESENT) (STANDARD PARTS)</b>	Ref.	—
—101	1682243	Lift Cylinder Assembly (See Section 5 for Breakdown)	1	
—102	3422073	Pin, Attach (Bottom Lift Cylinder)	1	
—103	3422074	Pin, Attach (Top Lift Cylinder)	1	
—104	0200458	Arm Weldment (2nd Inboard)	1	
—105	Not Used			
—106	Not Used			
—107	0200454	Arm Weldment (Bottom Inboard)	1	
—108	0200464	Arm Weldment (Bottom Outboard)	1	
	0961664	Bushing, Composite	4	
—109	0200452	Arm Weldment (4th Outboard)	2	
	0961664	Bushing, Composite (3 Per Arm)	6	
—110	0200463	Arm Weldment (4th Inboard)	1	
—111	0200462	Arm Weldment (3rd Inboard)	1	
—112	0200461	Arm Weldment (Top Inboard)	1	
—113	3421637	Pin, Attach	1	
—114	3421638	Pin, Attach	11	
—115	3421639	Pin, Attach	1	
—116	3421640	Pin, Attach	1	
—117	3421641	Pin, Attach	1	
—118	3421642	Pin, Attach	4	
—119	1440227	Collar	32	
—120	0200403	Arm Weldment (2nd Outboard - Left Side)	1	
	0961664	Bushing, Composite (Not Shown)	3	
—121	0641528	Bolt 5/16"-18NC x 3 1/2"	47	
—122	3311505	Locknut 5/16"-18NC	51	
—123	4843248	Prop, Safety	2	
—124	Not Used			
—125	0200402	Arm Weldment (2nd Outboard - Right Side)	1	
	0961664	Bushing, Composite	3	
—126	4751700	Flatwasher 7/16"	2	
—127	3340579	Pad, Sliding	4	
—128	0681714	Bolt 7/16"-13NC x 1 3/4" (Grade 8)	2	
—129	3311705	Locknut 7/16"-13NC	2	
—130	0200404	Arm Weldment (3rd Outboard)	2	
	0961664	Bushing, Composite (3 Per Arm)	6	
—131	0200465	Arm Weldment (Top Outboard)	1	
	0961664	Bushing, Composite	4	
—132	1320061	Clamp, Hose	4	
—133	0641508	Bolt 5/16"-18NC x 1"	4	
—134	Not Used			
—135	3841144	Pin, Keeper	2	
	3020028	Lube, Graphokote	A/R	
	0252588	<b>SIZZOR ARM PADS INSTALLATION</b>	Ref.	—
—201	3340645	Pad	32	

SECTION 3 SIZZOR ARMS

# SECTION 3

# SIZZOR ARMS

FIGURE 3-2. SIZZORS ARMS INSTALLATIONS - CM33RT.

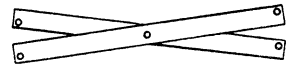

SECTION 3  
SIZZOR  
ARMS

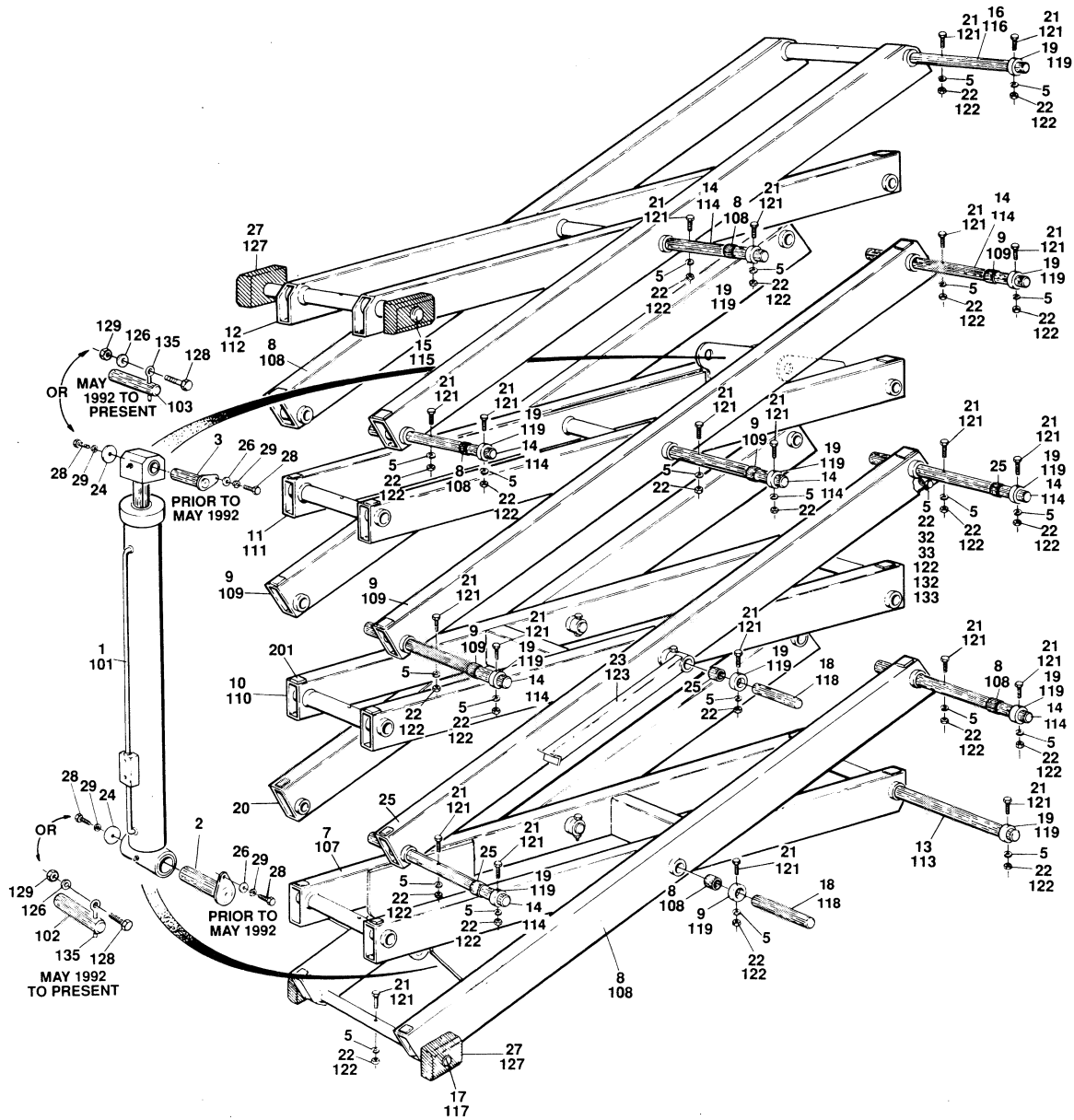

# SECTION 3

# SIZZOR ARMS

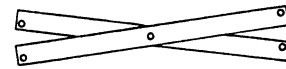

FIGURE & ITEM NO	PART NUMBER	DESCRIPTION	QTY.	REV.
3-2		<b>SIZZOR ARMS INSTALLATIONS - CM33RT</b>	Ref.	
	1281679	<b>SIZZOR ARMS INSTALLATIONS (MACHINES BUILT PRIOR TO MAY 1992) (STANDARD PARTS)</b>	Ref.	D
-1	1682593	Lift Cylinder Assembly (See Section 5 for Breakdown)	1	
-2	3421645	Pin, Attach (Bottom Lift Cylinder)	1	
-3	3421647	Pin, Attach (Top Lift Cylinder)	1	
-4	Not Used			
-5	4761500	Lockwasher 5/16"	46	
-6	Not Used			
-7	0200366	Arm Weldment (Bottom Inboard)	1	
-8	0200367	Arm Weldment (Bottom and Top Outboard)	2	
	0961409	Bushing, Super Oilite (8 Per Arm)	16	
-9	0200368	Arm Weldment (Upper Mid Outboard)	2	
	0961409	Bushing, Super Oilite (6 Per Arm)	12	
-10	0200369	Arm Weldment (Lower Mid Inboard)	1	
-11	0200370	Arm Weldment (Upper Mid Inboard)	1	
-12	0200371	Arm Weldment (Top Inboard)	1	
-13	3421637	Pin, Attach	1	
-14	3421639	Pin, Attach	8	
-15	3421639	Pin, Attach	1	
-16	3421640	Pin, Attach	1	
-17	3421641	Pin, Attach	1	
-18	3421642	Pin, Attach	4	
-19	1440227	Collar	32	
-20	0200373	Arm Weldment (Lower Mid Inboard - Left Side)	1	
	0961409	Bushing, Super Oilite	6	
-21	0641528	Bolt 5/16"-18NC x 3 1/2"	42	
-22	3311501	Nut 5/16"-18NC	46	
-23	4843248	Prop, Safety	2	
-24	4740303	Washer, Special	2	
-25	0200372	Arm Weldment (Lower Mid Inboard - Right Side)	1	
	0961409	Bushing, Super Oilite	6	
-26	4751800	Flatwasher 1/2"	2	
-27	3340579	Pad, Sliding	4	
-28	0641808	Bolt 1/2"-13NC x 1"	4	
-29	4761800	Lockwasher 1/2"	4	
-30	1320061	Clamp, Hose	4	
-31	Not Used			
-32	0641508	Bolt 5/16"-18NC x 1"	4	
	3020028	Lube, Graphokote	A/R	

SECTION 3 SIZZOR ARMS



# SECTION 3

# SIZZOR ARMS

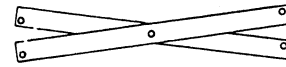
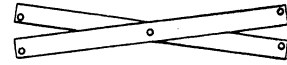

FIGURE & ITEM NO	PART NUMBER	DESCRIPTION	QTY.	REV.
3-2		<b>SIZZOR ARMS INSTALLATIONS - CM33RT (CONTINUED)</b>	Ref.	
	1281823	<b>SIZZOR ARMS INSTALLATION (MACHINES BUILT MAY 1992 TO PRESENT) (STANDARD PARTS)</b>	Ref.	—
—101	1682593	Lift Cylinder Assembly (See Section 5 for Breakdown)	1	
—102	3422073	Pin, Attach (Bottom Lift Cylinder)	1	
—103	3422074	Pin, Attach (Top Lift Cylinder)	1	
—104	Not Used			
—105	Not Used			
—106	Not Used			
—107	0200454	Arm Weldment (Bottom Inboard)	1	
—108	0200455	Arm Weldment (Bottom and Top Outboard)	2	
	0961409	Bushing, Super Oilite (8 Per Arm)	16	
—109	0200368	Arm Weldment (Upper Mid Outboard)	2	
	0961409	Bushing, Super Oilite (6 Per Arm)	12	
—110	0200458	Arm Weldment (Lower Mid Inboard)	1	
—111	0200457	Arm Weldment (Upper Mid Inboard)	1	
—112	0200456	Arm Weldment (Top Inboard)	1	
—113	3421637	Pin, Attach	1	
—114	3421638	Pin, Attach	8	
—115	3421639	Pin, Attach	1	
—116	3421640	Pin, Attach	1	
—117	3421641	Pin, Attach	1	
—118	3421642	Pin, Attach	4	
—119	1440227	Collar	26	
—120	0200373	Arm Weldment (Lower Mid Outboard - Left Side)	1	
	0961409	Bushing, Super Oilite (Not Shown)	6	
—121	0641528	Bolt 5/16"-18NC x 3 1/2"	42	
—122	3311505	Locknut 5/16"-18NC	46	
—123	4843248	Prop, Safety	2	
—124	Not Used			
—125	0200372	Arm Weldment (Lower Mid Outboard - Right Side)	1	
	0961409	Bushing, Super Oilite	6	
—126	4751700	Flatwasher 7/16"	2	
—127	3340579	Pad, Sliding	4	
—128	0681714	Bolt 7/16"-13NC x 1 3/4" (Grade 8)	2	
—129	3311705	Locknut 7/16"-13NC	2	
—130	1320061	Clamp, Hose	4	
—131	Not Used			
—132	0641508	Bolt 5/16"-18NC x 1"	4	
—133	3841144	Pin, Keeper	2	
	0252587	<b>SIZZOR ARM PADS INSTALLATION</b>	Ref.	—
—201	3340645	Pad	24	

SECTION 3 SIZZOR ARMS

# SECTION 3 SIZZOR ARMS

FIGURE 3-3. SIZZORS ARMS INSTALLATIONS - CM25RT.



SECTION 3 SIZZOR ARMS

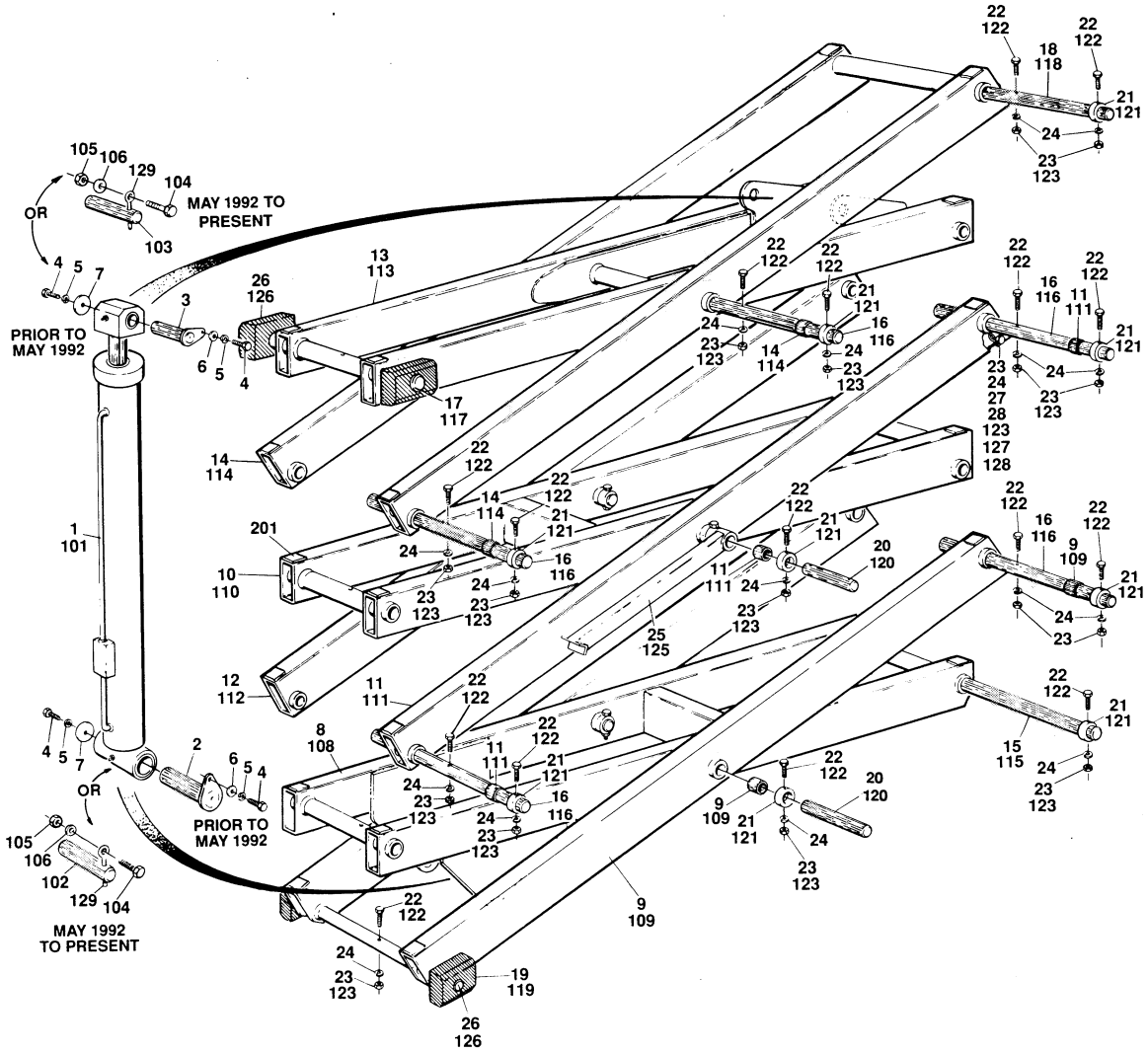

# SECTION 3

# SIZZOR ARMS

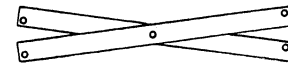

FIGURE & ITEM NO	PART NUMBER	DESCRIPTION	QTY.	REV.
3-3		<b>SIZZORS ARMS INSTALLATIONS - CM25RT</b>	Ref.	
	1281361	<b>SIZZOR ARMS INSTALLATIONS (MACHINES BUILT PRIOR TO MAY 1992) (STANDARD PARTS)</b>	Ref.	B
-1	1682593	Lift Cylinder Assembly (See Section 5 for Breakdown)	1	
-2	3421645	Pin, Attach (Bottom Lift Cylinder)	1	
-3	3421647	Pin, Attach (Top Lift Cylinder)	1	
-4	0641808	Bolt 1/2"-13NC x 1"	4	
-5	4761800	Lockwasher 1/2"	4	
-6	4751800	Flatwasher 1/2"	2	
-7	4740303	Washer, Special	2	
-8	0200366	Arm Weldment (Bottom Inboard)	1	
-9	0200367	Arm Weldment (Bottom Outboard)	1	
	0961409	Bushing, Super Oilite	8	
-10	0200369	Arm Weldment (Mid Inboard)	1	
-11	0200372	Arm Weldment (Mid Outboard - Right Side)	1	
	0961409	Bushing, Superoilite	6	
-12	0200373	Arm Weldment (Mid Outboard - Left Side)	1	
	0961409	Bushing, Super Oilite (Not Shown)	6	
-13	0200419	Arm Weldment (Top Inboard)	1	
-14	0200408	Arm Weldment (Top Outboard)	1	
	0961409	Bushing, Super Oilite	8	
-15	3421637	Pin, Attach	1	
-16	3421638	Pin, Attach	5	
-17	3421639	Pin, Attach	1	
-18	3421640	Pin, Attach	1	
-19	3421641	Pin, Attach	1	
-20	3421642	Pin, Attach	4	
-21	1440227	Collar	20	
-22	0641528	Bolt 5/16"-18NC x 3 1/2"	33	
-23	3311501	Nut 5/16"-18NC	35	
-24	4761500	Lockwasher 5/16"	35	
-25	4843248	Prop Safety	2	
-26	3340579	Pad, Sliding	4	
-27	1320061	Clamp, Hose	2	
-28	0641508	Bolt 5/16"-18NC x 1"	2	
	1281822	<b>SIZZOR ARMS INSTALLATION (MACHINES BUILT MAY 1992 TO PRESENT) (STANDARD PARTS)</b>	Ref.	—
-101	1682593	Lift Cylinder Assembly (See Section 5 for Breakdown)	1	
-102	3422073	Pin, Attach (Bottom Lift Cylinder)	1	
-103	3422074	Pin, Attach (Top Lift Cylinder)	1	
-104	0681714	Bolt 7/16"-14NC x 1 3/4" (Grade 8)	2	
-105	3311705	Locknut 7/16"-14NC	2	
-106	4751700	Flatwasher 7/16"	2	
-107	Not Used			
-108	0200454	Arm Weldment (Bottom Inboard)	1	

SECTION 3 SIZZOR ARMS





# SECTION 3

# SIZZOR ARMS

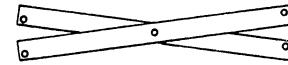
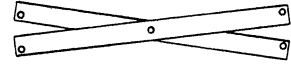

FIGURE & ITEM NO	PART NUMBER	DESCRIPTION	QTY.	REV.
3-3		<b>SIZZORS ARMS INSTALLATIONS - CM25RT (CONTINUED)</b>	Ref.	
-109	0200455	Arm Weldment (Bottom Outboard)	1	
	0961409	Bushing, Super Oilite	8	
-110	0200458	Arm Weldment (Mid Inboard)	1	
-111	0200372	Arm Weldment (Mid Outboard - Right Side)	1	
	0961409	Bushing, Super Oilite	6	
-112	0200373	Arm Weldment (Mid Outboard - Left Side)	1	
	0961409	Bushing, Super Oilite (Not Shown)	6	
-113	0200460	Arm Weldment (Top Inboard)	1	
-114	0200459	Arm Weldment (Top Outboard)	1	
	0961409	Bushing, Super Oilite	8	
-115	3421637	Pin, Attach	1	
-116	3421638	Pin, Attach	5	
-117	3421639	Pin, Attach	1	
-118	3421640	Pin, Attach	1	
-119	3421641	Pin, Attach	1	
-120	3421642	Pin, Attach	4	
-121	1440227	Collar	26	
-122	0641528	Bolt 5/16"-18NC x 3 1/2"	33	
-123	3311505	Locknut 5/16"-18NC	35	
-124	Not Used			
-125	4843248	Prop, Safety	2	
-126	3340579	Pad, Sliding	4	
-127	1320061	Clamp, Hose	2	
-128	0641508	Bolt 5/16"-18NC x 1"	2	
-129	3841144	Pin, Keeper	2	
	0252586	<b>SIZZOR ARM PADS INSTALLATION</b>	Ref.	—
-201	3340645	Pad	16	

SECTION 3 SIZZOR ARMS

# SECTION 3 SIZZOR ARMS

FIGURE 3-4. SIZZOR ARM GUARDS INSTALLATION.



SECTION 3 SIZZOR ARMS

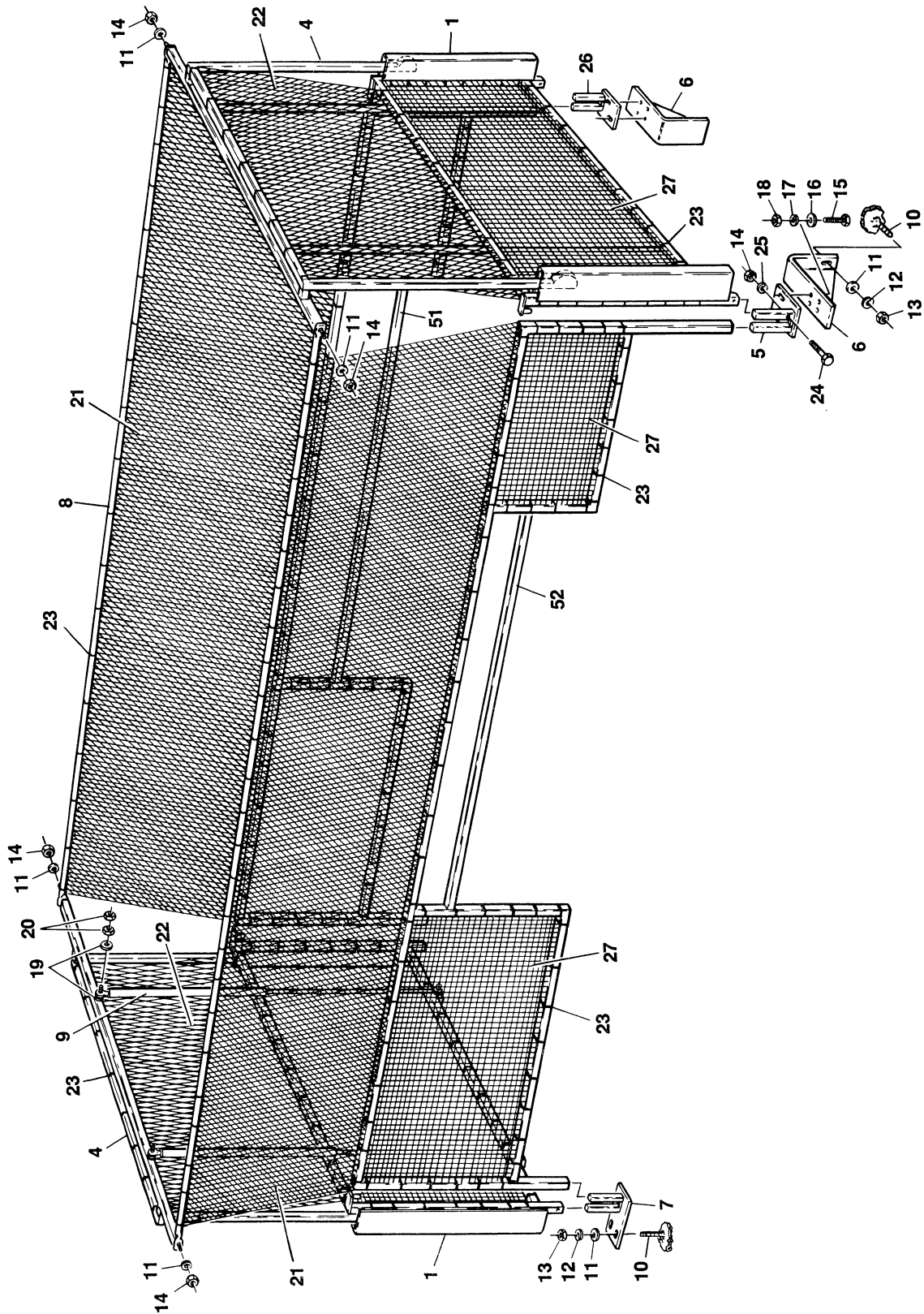

# SECTION 3 SIZZOR ARMS

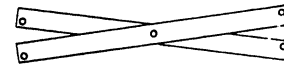
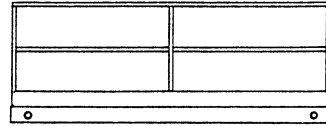

FIGURE & ITEM NO	PART NUMBER	DESCRIPTION	QTY.	REV.
3-4		<b>SIZZOR ARMS GUARD INSTALLATION</b>	Ref.	
		<b>SIZZOR ARMS GUARD INSTALLATION (STANDARD PARTS)</b>	Ref.	
-1	4843936	Guard Weldment (Front and Rear)	2	
-2	Not Used			
-3	Not Used			
-4	4843800	Guide, Belt	2	
-5	4843807	Bracket, Mounting (Front Right)	1	
-6	4843810	Support, Guard (Front Lower)	2	
-7	4843811	Bracket, Mounting (Rear)	2	
-8	4340611	Bar, Support	2	
-9	4160102	Spring, Gas	4	
-10	4300048	Stud (Welded on Part)	8	
-11	4711800	Flatwasher 1/2" Narrow	12	
-12	4761800	Lockwasher 1/2"	8	
-13	3311801	Nut 1/2"-13NC	8	
-14	3311805	Locknut 1/2"-13NC	4	
-15	0641610	Bolt 3/8"-16NC x 1 1/4"	4	
-16	3311601	Nut 3/8"-16NC	4	
-17	4761600	Lockwasher 3/8"	4	
-18	4711600	Flatwasher 3/8" Narrow	8	
-19	4711500	Flatwasher 5/16" Narrow	48	
-20	3311501	Nut 5/16"-18NC	20	
-21	0480064	Mesh, Wire (Upper Sides)	2	
-22	0480065	Mesh, Wire (Upper Ends)	2	
-23	4240033	Tie-Strap	A/R	
-24	0641514	Bolt 5/16"-18NC x 1 3/4"	4	
-25	4761500	Lockwasher 5/16"	4	
-26	4843876	Bracket, Mounting (Front Left)	1	
-27	4921380	Mesh, Wire (Lower Sides and Ends)	9 ft./2.75m	
	0252049	<b>SIZZOR ARMS GUARD INSTALLATION (DIESEL/STANDARD GAS) (VARIABLE PARTS)</b>	Ref.	A
-51	4843937	Guard (Left Side)	1	
-52	4843938	Guard (Right Side)	1	
	0252340	<b>SIZZOR ARMS GUARD INSTALLATION (DUAL FUEL GAS/ELECTRIC) (VARIABLE PARTS)</b>	Ref.	A
-51	4844035	Guard (Left Side)	1	
	4844035	Guard (Right Side)	1	

**SECTION 3 SIZZOR ARMS**



# SECTION 4 PLATFORM



## TABLE OF CONTENTS

FIGURE NO.	DESCRIPTION	PAGE NO.
4-1	Standard Platform and Optional Components Installation .....	4-2
4-2	Extendable Platform Installation (Optional) .....	4-6
4-3	Traversing Platform Installation (Optional) .....	4-8
4-4	Platform Control Box Installation .....	4-10

**SECTION 4 PLATFORM**

# SECTION 4 PLATFORM

FIGURE 4-1. STANDARD PLATFORM AND OPTIONAL COMPONENTS INSTALLATION.

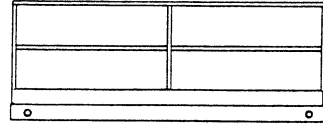

SECTION 4 PLATFORM

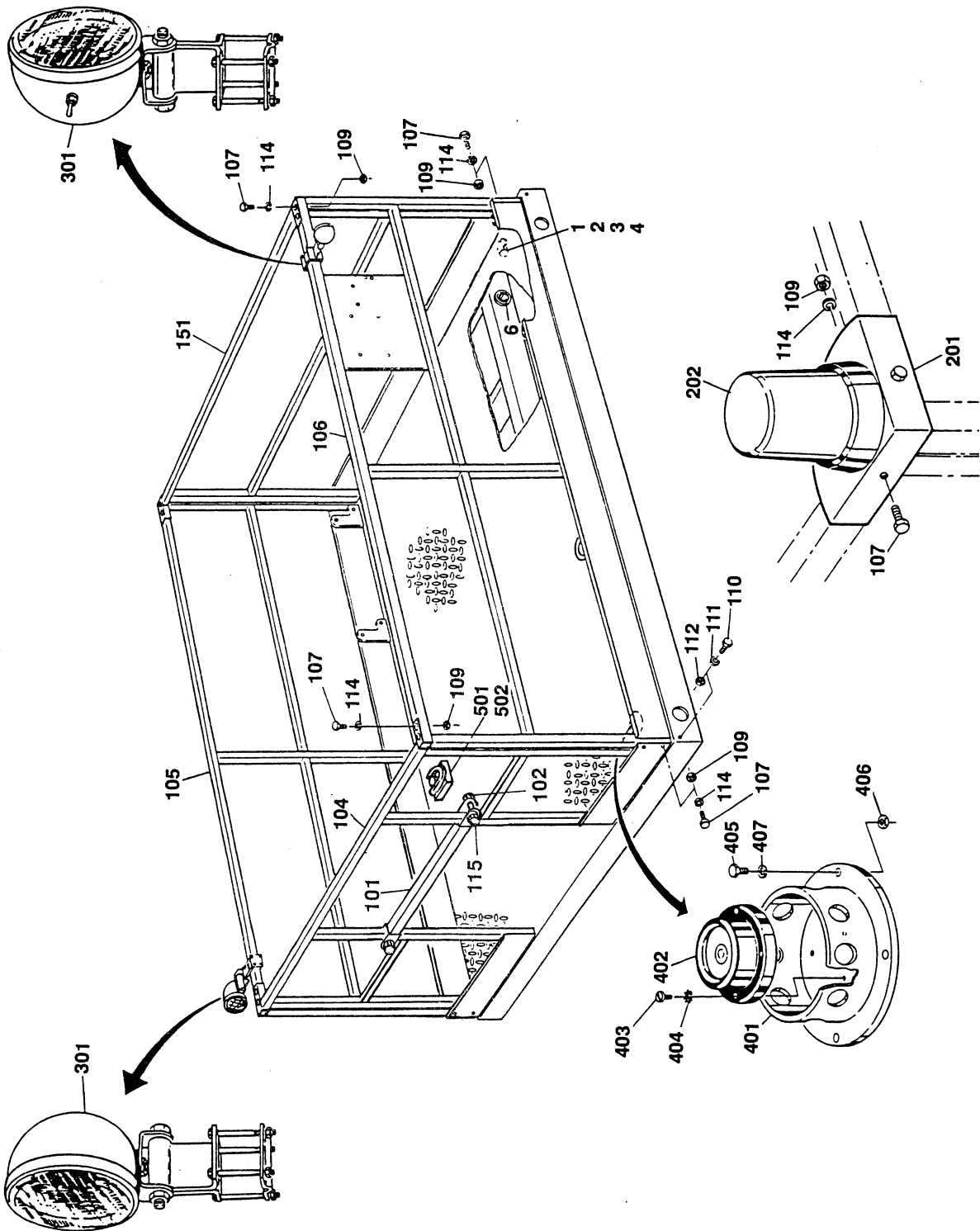

# SECTION 4 PLATFORM

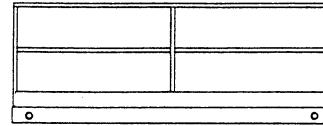

FIGURE & ITEM NO	PART NUMBER	DESCRIPTION	QTY.	REV.
4-1		<b>STANDARD PLATFORM AND OPTIONAL COMPONENTS INSTALLATION</b>	Ref.	
	3510203	<b>STANDARD PLATFORM WELDMENT (STANDARD PARTS)</b>	Ref.	D
-1	4300038	Stud (Welded on Part)	1	
-2	3311501	Nut 5/16"-18NC	1	
-3	4761500	Lockwasher 5/16"	1	
-4	1320095	Clamp	1	
-5	Not Used			
-6	0961409	Bushing, Super Oilite (2 Per Channel)	4	
	1281290	<b>HANDRAILS INSTALLATION (STANDARD PARTS)</b>	Ref.	C
-101	3640642	End - Gate	1	
-102	3311405	Locknut 1/4"-20NC	2	
-103	Not Used			
-104	3640685	Rail Weldment - Rear	1	
-105	3640680	Rail Weldment - Left Side	1	
-106	3640681	Rail Weldment - Right Side	1	
-107	0641416	Bolt 1/4"-20NC x 2"	A/R	
-108	Not Used			
-109	3311405	Locknut 1/4"-20NC	A/R	
-110	0641518	Bolt 5/16"-18NC x 2 1/4"	4	
-111	4751500	Flatwasher 5/16"	4	
-112	3311505	Locknut 5/16"-18NC	4	
-113	Not Used			
-114	4751400	Flatwasher 1/4"	12	
-115	0641418	Bolt 1/4"-20NC x 2 1/4"	2	
	0251153	<b>HANDRAILS INSTALLATION (STANDARD AND TRAVERSING PLATFORMS) (VARIABLE PARTS)</b>	Ref.	B
	0251154	<b>HANDRAILS INSTALLATION (EXTENDABLE PLATFORM) (VARIABLE PARTS)</b>	Ref.	A
-151	3640682	Rail Weldment - Front (Standard and Traversing Platforms)	1	
	Not Required	Rail Weldment - Front (Extendable Platforms)	1	
	0250809	<b>ROTATING BEACON LIGHT INSTALLATION (OPTIONAL)</b>	Ref.	—
-201	0901113	Bracket, Mounting	1	
-202	2920018	Light, Beacon (Amber)	1	
	0251805	<b>PLATFORM WORK LIGHTS INSTALLATION (OPTIONAL)</b>	Ref.	—
-301	2920013	Floodlight	2	
	0250317	<b>CIRCULAR LEVEL INSTALLATION (OPTIONAL)</b>	Ref.	—
-401	4842981	Bracket, Mounting	1	

SECTION 4 PLATFORM





# SECTION 4 PLATFORM

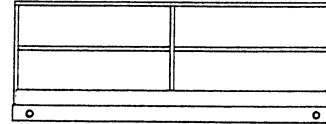
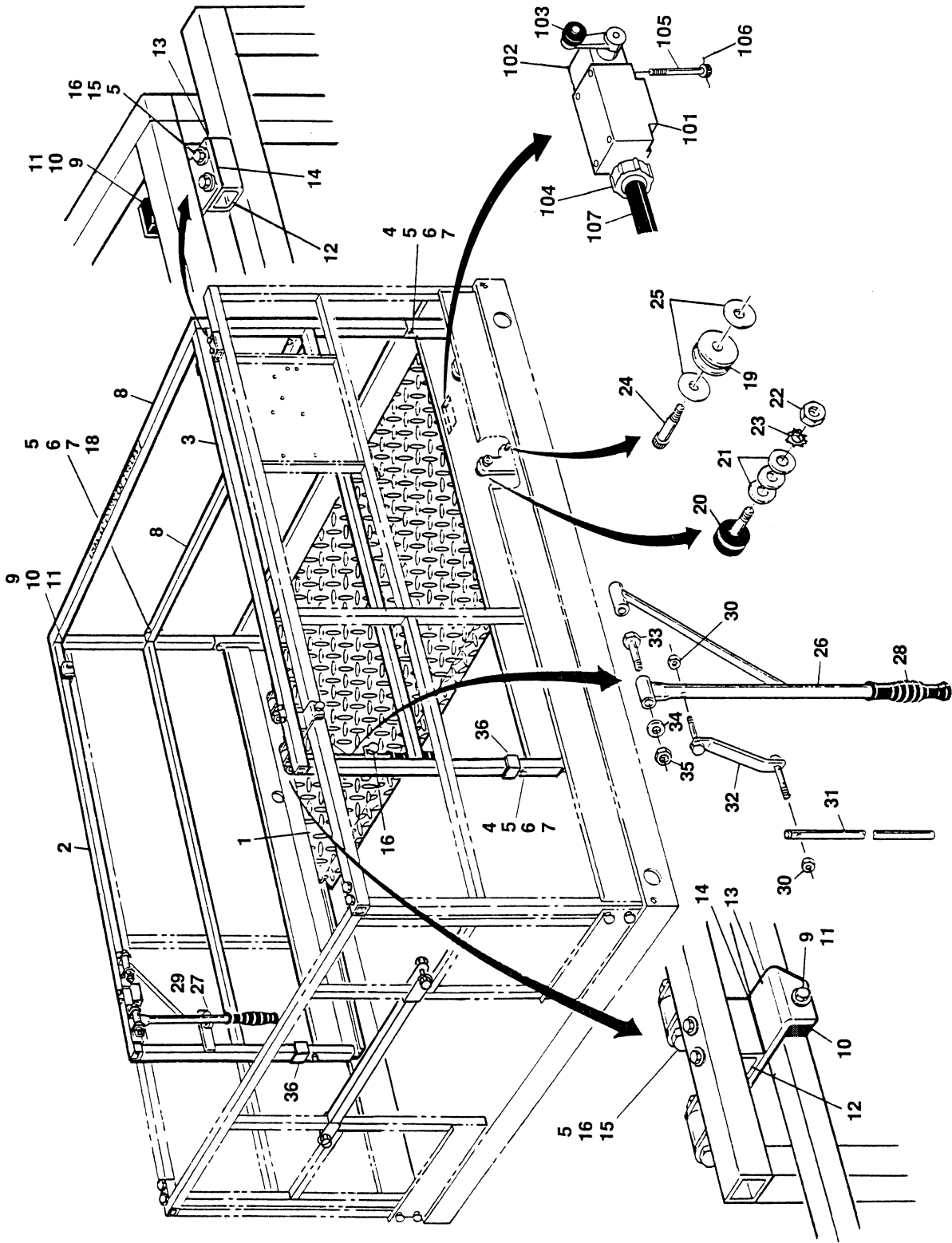
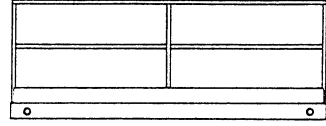

FIGURE & ITEM NO	PART NUMBER	DESCRIPTION	QTY.	REV.
4-1		<b>STANDARD PLATFORM AND OPTIONAL COMPONENTS INSTALLATION (CONTINUED)</b>	Ref.	
-402	2420038	Level, Circular	1	
-403	3910610	Screw #6-32NC x 5/8"	3	
-404	4770600	Starwasher #6	3	
-405	0641406	Bolt 1/4"-20NC x 3/4"	4	
-406	3311401	Nut 1/4"-20NC	4	
-407	4761400	Lockwasher 1/4"	4	
	0250999	<b>HARNES ATTACH RINGS INSTALLATION (OPTIONAL)</b>	Ref.	—
-501	3534309	Plate, Attach	2	
-502	3760274	Ring, Lanyard Swivel	2	

SECTION 4 PLATFORM

# SECTION 4 PLATFORM

FIGURE 4-2. EXTENDABLE PLATFORM INSTALLATION (OPTIONAL).



# SECTION 4

# PLATFORM

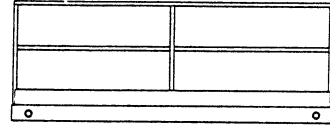
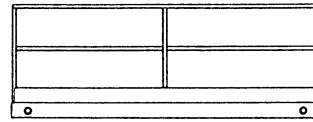

FIGURE & ITEM NO	PART NUMBER	DESCRIPTION	QTY.	REV.
4-2	0252412	<b>EXTENDABLE PLATFORM INSTALLATION (OPTIONAL)</b>	Ref.	C
-1	3510357	Platform Extension Weldment	1	
-2	3640783	Rail Weldment - Left Side	1	
-3	3640784	Rail Weldment - Right Side	1	
-4	0641414	Bolt 1/4"-20NC x 1 3/4"	4	
-5	4751400	Flatwasher 1/4"	28	
-6	4761400	Lockwasher 1/4"	8	
-7	3311401	Nut 1/4"-20NC	8	
-8	4565554	Rail, Front	2	
-9	0641605	Bolt 3/8"-16NC x 5/8"	4	
-10	3340587	Pad, Wear	4	
-11	4761600	Lockwasher 3/8"	4	
-12	4565312	Spacer	4	
-13	0181515	Angle, Mounting	4	
-14	3532918	Plate, Doubler	A/R	
-15	0641424	Bolt 1/4"-20NC x 3"	8	
-16	3311405	Locknut 1/4"-20NC	8	
-17	Not Used			
-18	0641416	Bolt 1/4"-20NC x 2"	4	
-19	3860049	Roller	4	
-20	0440085	Bearing	4	
-21	4712200	Flatwasher 3/4" Narrow	12	
-22	3322002	Nut, Jam 5/8"-18NF	4	
-23	4792000	Starwasher 5/8"	4	
-24	3900163	Bolt, Bearing	4	
-25	4740350	Flatwasher, Special	8	
-26	4843336	Handle	2	
-27	3941004	Screw, Self-Tapping #10	2	
-28	2560088	Grip, Handle	2	
-29	1380132	Clip, Gripper	2	
-30	3311505	Locknut 5/16"-18NC	4	
-31	3841154	Rod, Latch	2	
-32	0200409	Arm, Latch	2	
-33	0641620	Bolt 3/8"-16NC x 2 1/2"	4	
-34	4751600	Flatwasher 3/8"	4	
-35	3311605	Locknut 3/8"-16NC	4	
-36	4100038	Sleeve, Plastic	4	
	0251704	<b>PLATFORM EXTENSION LIMIT SWITCH INSTALLATION (FRENCH AND ITALIAN SPEC ONLY)</b>	Ref.	A
-101	4360277	Switch, Limit	1	
-102	4360236	Head, Actuator	1	
-103	4360278	Arm and Roller	1	
-104	4460052	Connector, Strain Relief	1	
-105	3900168	Screw, Special	2	
-106	4920140	Lockwire	2	
-107	1060341	Cable, Electrical - 16/2	15 ft./4.6m	

SECTION 4 PLATFORM

# SECTION 4 PLATFORM

FIGURE 4-3. TRAVERSING PLATFORM INSTALLATION (OPTIONAL).



SECTION 4 PLATFORM

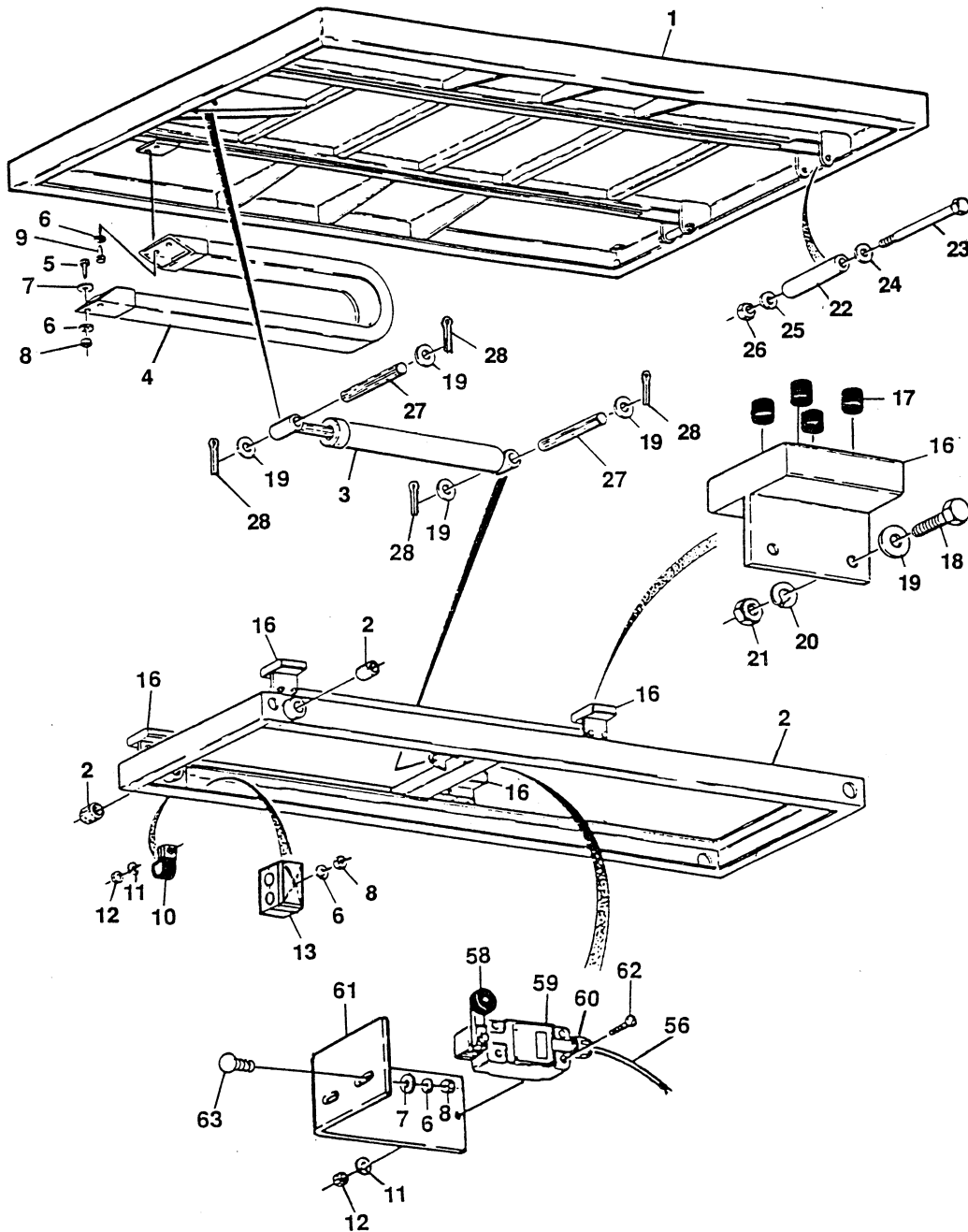

# SECTION 4

# PLATFORM

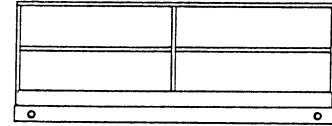
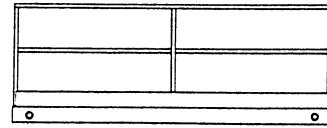

FIGURE & ITEM NO	PART NUMBER	DESCRIPTION	QTY.	REV.
4-3		<b>TRAVERSING PLATFORM INSTALLATION (OPTIONAL)</b>	Ref.	
	1281563	<b>TRAVERSING PLATFORM INSTALLATION - WITHOUT OUTRIGGERS (STANDARD PARTS WHEN EQUIPPED)</b>	Ref.	A
	1281610	<b>TRAVERSING PLATFORM INSTALLATION - WITH OUTRIGGERS (STANDARD PARTS WHEN EQUIPPED)</b>	Ref.	—
—1	3510251	Platform Weldment	1	
—2	3510250	Sub-Deck Weldment	1	
	0961409	Bushing, Super Oilite	4	
—3	1681591	Extension Cylinder Assembly (See Section 5 for Breakdown)	1	
—4	1180172	Carrier	1	
—5	0641408	Bolt 1/4"-20NC x 1"	2	
—6	4761400	Lockwasher 1/4"	8	
—7	4751400	Flatwasher 1/4"	4	
—8	3311401	Nut 1/4"-20NC	6	
—9	0641405	Bolt 1/4"-20NC x 5/8"	2	
—10	1320169	Clamp	2	
—11	4761000	Lockwasher #10	4	
—12	3311001	Nut #10-24NC	4	
—13	1320159	Clamp	2	
—14	Not Used			
—15	Not Used			
—16	4843637	Block, Slide	4	
—17	3340590	Pad, Wear	16	
—18	0642212	Bolt 3/4"-10NC x 1 1/2"	8	
—19	4752200	Flatwasher 3/4"	12	
—20	4762200	Lockwasher 3/4"	8	
—21	3312201	Nut 3/4"-10NC	8	
—22	0961461	Bushing	2	
—23	0641852	Bolt 1/2"-13NC x 6 1/2"	2	
—24	4751800	Flatwasher 1/2"	2	
—25	4761800	Lockwasher 1/2"	2	
—26	3311801	Nut 1/2"-13NC	2	
—27	3421327	Pin, Attach (Extension Cylinder)	2	
—28	3450406	Pin, Cotter 1/8" x 1 1/2"	4	
		<b>LIMIT SWITCH INSTALLATION</b>	Ref.	
—56	1060016	Cable, Electrical - 16/3	A/R	
—57	Not Used			
—58	4360298	Roller and Arm	1	
—59	4360277	Switch, Limit	1	
	4360236	Head, Actuator	1	
—60	4460049	Connector, Strain Relief	1	
—61	0901761	Bracket, Mounting	1	
—62	0721016	Screw, Machine #10-24NC x 2"	2	
—63	4300085	Stud (Welded on Part)	2	

SECTION 4 PLATFORM

# SECTION 4 PLATFORM

FIGURE 4-4. PLATFORM CONTROL BOX INSTALLATION.



SECTION 4 PLATFORM

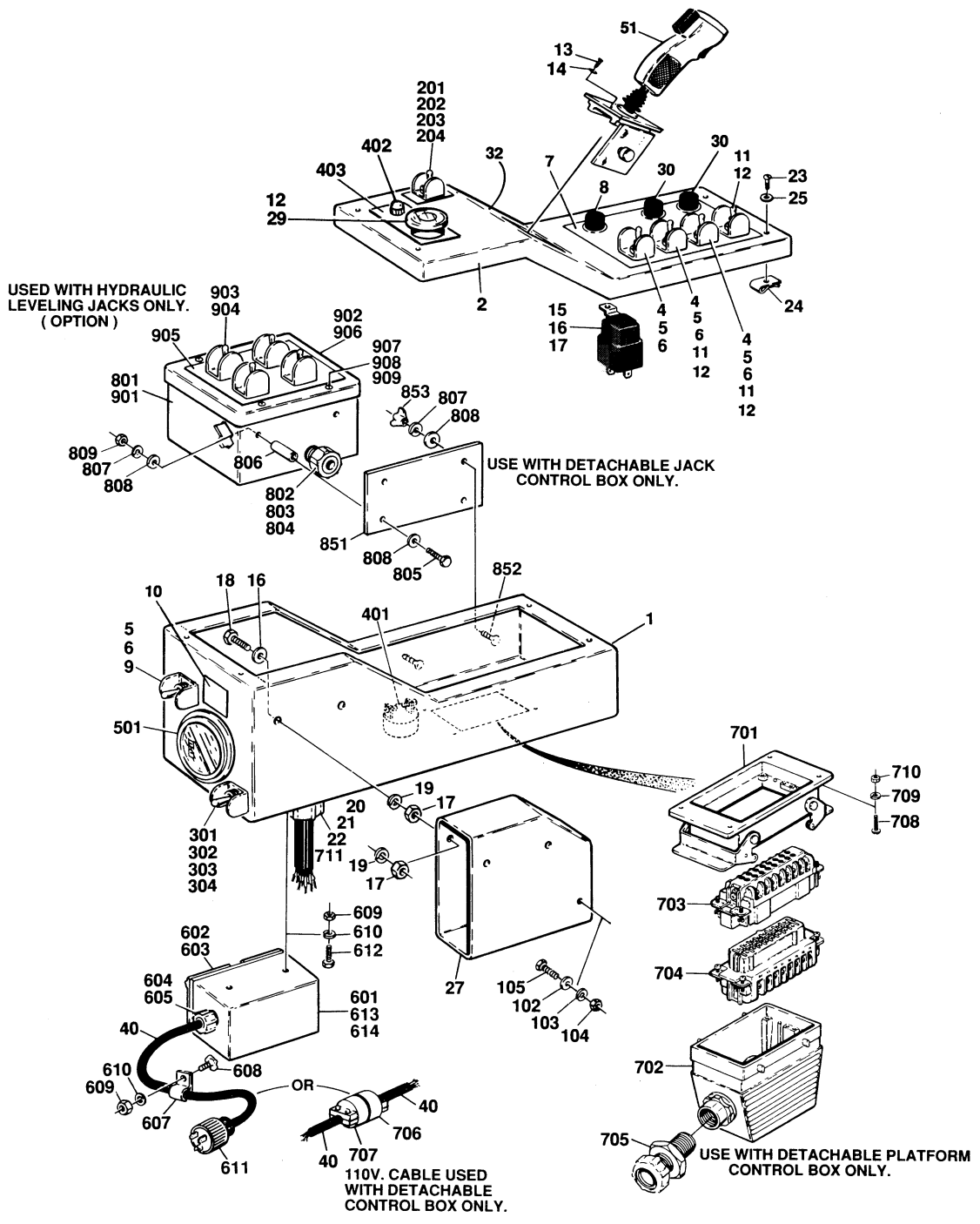

# SECTION 4

# PLATFORM

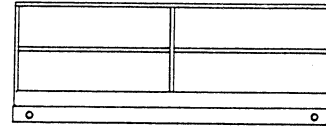
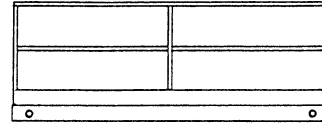

FIGURE & ITEM NO	PART NUMBER	DESCRIPTION	QTY.	REV.
4-4		<b>PLATFORM CONTROL BOX INSTALLATION</b>	Ref.	
		<b>PLATFORM CONTROL BOX ASSEMBLY (STANDARD PARTS)</b>	Ref.	
-1	3532969	Box, Control	1	
-2	4843787	Lid	1	
-3	Not Used			
-4	4360199	Switch, Toggle - SPST (Engine Speed and Pump Speed Gas/Diesel Machines) (Drive Speed, and Pump Speed Electric Machines)	2	
-5	3790012	O-Ring	3	
-6	4060229	Shield, Switch	3	
-7	1701452	Decal - Platform Control	1	
-8	4360274	Switch, Push Button - SPST/MC (Start and Horn)	A/R	
-9	4360260	Switch, Toggle - DPDT/MC/CO (Lift)	1	
-10	1701453	Nametag - Lift	1	
-11	3520028	Plug, Hole - 1/2"	A/R	
-12	0100035	Loctite #222	A/R	
-13	3910808	Screw, Machine #8-32NC x 1 1/2"	2	
-14	4760800	Lockwasher #8	2	
-15	3740049	Relay	A/R	
-16	4751400	Flatwasher 1/4"	4	
-17	3311401	Nut 1/4"-20NC	7	
-18	0641408	Bolt 1/4"-20NC x 1"	3	
-19	4761400	Lockwasher 1/4"	6	
-20	4460071	Connector, Strain Relief - 3/4"	1	
-21	3300048	Nut, Conduit - 3/4"	1	
-22	0960238	Bushing 3/4"	1	
-23	0750806	Screw, Self-Tapping #8 x 3/4"	4	
-24	3300177	Nut, Tinnerman	4	
-25	4740120	Washer, Nylon	4	
-26	Not Used			
-27	4564494	Spacer, Tube	1	
-28	Not Used			
-29	4360289	Switch, Push-Pull	1	
-30	3520026	Plug, Hole - 5/8"	A/R	
-31	Not Used			
-32	1701454	Decal - Steering	1	
	0252487	<b>PLATFORM CONTROL BOX ASSEMBLY - DIESEL MACHINES (VARIABLE PARTS)</b>	Ref.	A
	0253066	<b>PLATFORM CONTROL BOX ASSEMBLY - GAS MACHINES (VARIABLE PARTS)</b>	Ref.	—
-51	1600148	Controller	1	
	0251936	<b>PLATFORM CONTROL BOX ASSEMBLY - ELECTRIC MACHINES (VARIABLE PARTS)</b>	Ref.	—
-51	1600115	Controller	1	

SECTION 4 PLATFORM

# SECTION 4 PLATFORM



SECTION 4 PLATFORM

FIGURE & ITEM NO	PART NUMBER	DESCRIPTION	QTY.	REV.
4-4		<b>PLATFORM CONTROL BOX INSTALLATION (CONTINUED)</b>	Ref.	
		<b>PLATFORM CONTROL BOX INSTALLATION (STANDARD PARTS)</b>	Ref.	
-101	Not Used			
-102	4751400	Flatwasher 1/4"	6	
-103	4761400	Lockwasher 1/4"	3	
-104	3311401	Nut 1/4"-20NC	3	
-105	0641406	Bolt 1/4"-20NC x 3/4"	3	
	1281563	<b>CONTROLS INSTALLATION - TRAVERSING PLATFORM (OPTIONAL)</b>	Ref.	—
-201	4360202	Switch, Toggle	1	
-202	3790012	O-Ring	1	
-203	4060229	Shield, Switch	1	
-204	3252000	Nametag - Platform Extend	1	
	0251800	<b>CONTROLS INSTALLATION - HEAD LIGHTS (OPTIONAL)</b>	Ref.	—
-301	4360199	Switch, Toggle - SPST	1	
-302	3790012	O-Ring	1	
-303	4060229	Shield, Switch	1	
-304	3250630	Nametag - Headlights	1	
		<b>TILT INDICATOR INSTALLATION</b>	Ref.	
-401	0140019	Alarm	1	
-402	2920026	Light, Indicator	1	
	2920029	Bulb, Light	1	
-403	1701489	Decal - Tilt	1	
	0251319	<b>BATTERY CAPACITY GAGE INSTALLATION (OPTIONAL)</b>	Ref.	—
-501	2420075	Gauge	1	
		<b>RECEPTACLE INSTALLATION (OPTIONAL)</b>	Ref.	
-601	0860038	Box, Switch	1	
-602	Supply Locally	Receptacle	1	
-603	Supply Locally	Shield, Cover	1	
-604	4460049	Connector, Strain Relief	1	
-605	0960407	Bushing	1	
-606	Not Used			
-607	1320041	Clamp	1	
-608	4300032	Stud (Welded on Part)	1	
-609	3311401	Nut 1/4"-20NC	3	
-610	4761400	Lockwasher 1/4"	3	
-611	Supply Locally	Plug, Connector	1	
-612	0641406	Bolt 1/4"-20NC x 3/4"	2	



# SECTION 4

# PLATFORM

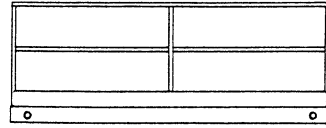
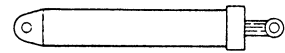

FIGURE & ITEM NO	PART NUMBER	DESCRIPTION	QTY.	REV.
4-4		<b>PLATFORM CONTROL BOX INSTALLATION (CONTINUED)</b>	Ref.	
-613	1700598	Decal - Ground	1	
-614	1700599	Decal - Neutral	1	
	0250762	<b>DETACHABLE CONTROL BOX INSTALLATION (OPTIONAL)</b>	Ref.	—
-701	4460359	Base, Mounting	1	
-702	4460360	Hood, Side Entry	1	
-703	4460361	Terminal, Female	1	
-704	4460362	Terminal, Male	1	
-705	4460051	Connector, Strain Relief	1	
-706	4460205	Plug, Twist-Lock - Male	1	
-707	4460134	Plug, Twist-Lock - Female	1	
-708	3910808	Screw, Machine #8-32NC x 1/2"	4	
-709	4760800	Lockwasher #8	4	
-710	3310801	Nut #8-32NC	4	
-711	3520035	Plug, Hole - 1"	1	
	0250153	<b>LEVELING JACK CONTROL BOX INSTALLATION (OPTIONAL - STANDARD PARTS WHEN EQUIPPED)</b>	Ref.	—
-801	0860533	Control Box Assembly (See Items 901-909 for Breakdown)	1	
-802	4460052	Connector, Strain Relief	1	
-803	0960239	Bushing	1	
-804	3300047	Locknut, Conduit	1	
-805	0641410	Bolt 1/4"-20NC x 1 1/4"	2	
-806	4562298	Spacer, Tube	2	
-807	4761400	Lockwasher 1/4"	A/R	
-808	4751400	Flatwasher 1/4"	A/R	
-809	3311401	Nut 1/4"-20NC	2	
	0251131	<b>LEVELING JACK CONTROL BOX INSTALLATION (OPTIONAL - VARIABLE PARTS WHEN EQUIPPED WITH DETACHABLE CONTROL BOX)</b>	Ref.	—
-851	3534487	Plate, Mounting	1	
-852	4300083	Stud (Welded on Part)	2	
-853	3300202	Wingnut 1/4"-20NC	2	
	0860533	<b>LEVELING JACK CONTROL ASSEMBLY (OPTIONAL)</b>	Ref.	B
-901	0860556	Box, Control	1	
-902	1670469	Cover	1	
-903	4060229	Shield, Switch	4	
-904	4360202	Switch, Toggle - DPDT/MC	4	
-905	3251795	Nameplate - Controls	1	
-906	4420008	Tape, Sealing	2 ft./6m	
-907	0750804	Screw, Self-Tapping #8 x 1/2"	4	
-908	4770800	Starwasher #8	4	
-909	3300177	Nut, Tinnerman	4	

SECTION 4 PLATFORM



# SECTION 5 CYLINDERS



## TABLE OF CONTENTS

FIGURE NO.	DESCRIPTION	PAGE NO.
5-1	Axle Lockout Cylinder Assembly .....	5-2
5-2	Leveling Jack Cylinder Assembly .....	5-4
5-3	Lift Cylinder Assemblies .....	5-6
5-4	Steer Cylinder Assembly .....	5-10
5-5	Traversing Platform Extension Cylinder Assembly .....	5-12

SECTION 5 CYLINDERS

# SECTION 5 CYLINDERS

FIGURE 5-1. AXLE LOCKOUT CYLINDER ASSEMBLY (OSCILLATING AXLE OPTION).

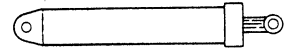

SECTION 5 CYLINDERS

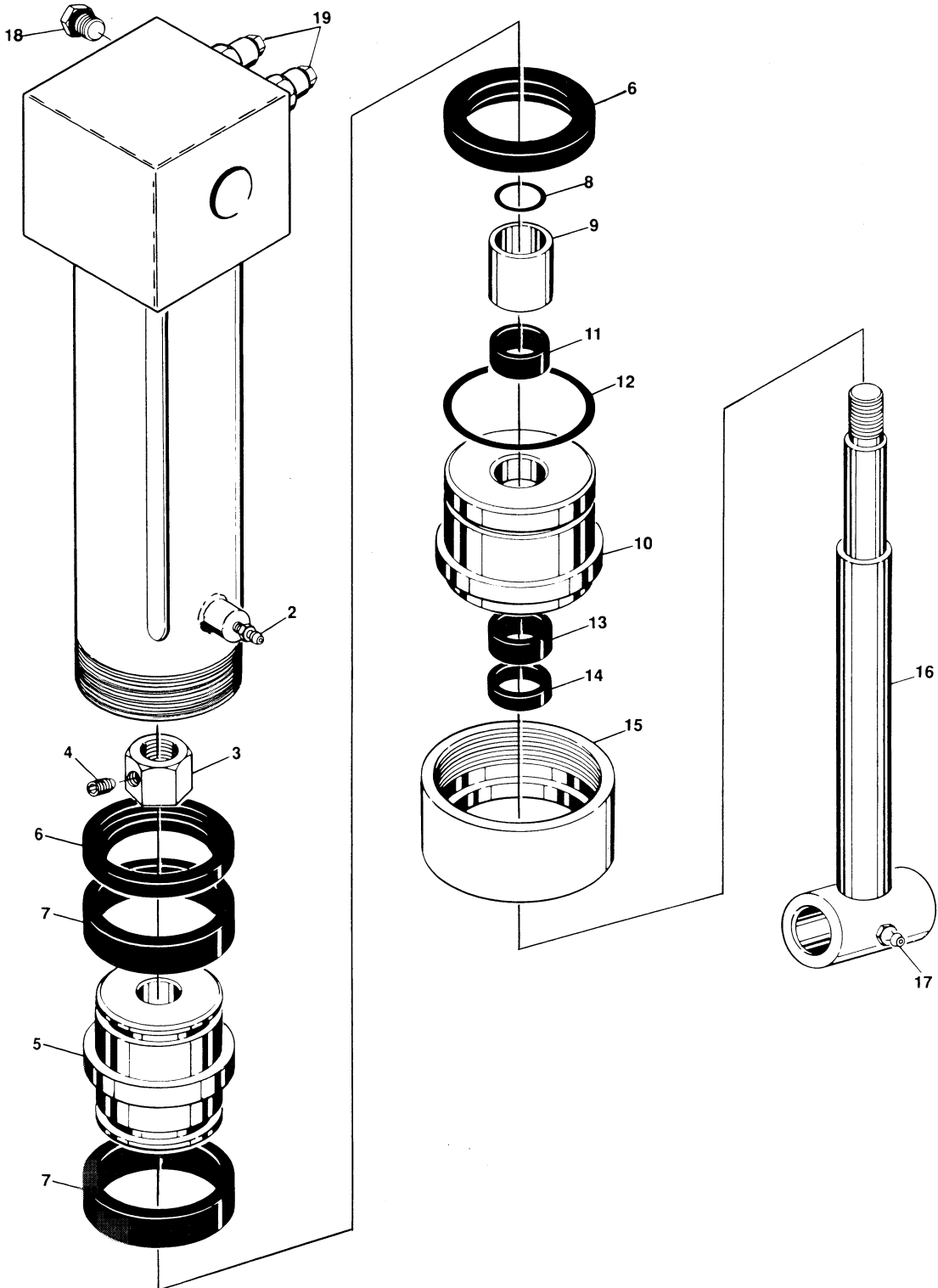

# SECTION 5 CYLINDERS

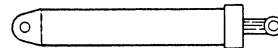

FIGURE & ITEM NO	PART NUMBER	DESCRIPTION	QTY:	REV.
5-1	1682427	<b>AXLE LOCKOUT CYLINDER ASSEMBLY (OSCILLATING AXLE OPTION)</b>	Ref.	b
-1	1682428	Barrel Assembly	1	
-2	4640273	Bleeder	1	
-3	3300273	Nut, Hex	1	
	0100011	Loctite #242	A/R	
-4	3900170	Set Screw 3/8"-16NC x 3/8"	1	
-5	3480116	Piston	1	
-6	Kit	Seal	2	
-7	Kit	Ring, Lock	2	
-8	Kit	O-Ring	1	
-9	4564606	Spacer	1	
-10	1681322	Head	1	
-11	Kit	Ring	1	
-12	Kit	O-Ring	2	
-13	Kit	Seal, Rod	1	
-14	Kit	Seal, Wiper	1	
-15	1120108	Head, Retainer	1	
	0100035	Loctite #222	A/R	
-16	1681609	Rod Assembly	1	
-17	2160002	Fitting, Grease	1	
-18	2220237	Fitting, Plug	2	
-19	4640525	Valve, Check - Pilot - Operated	2	
	2900379	Seal Kit (Includes Items 6,7,8,11,12,13 and 14)	1	
	2900770	Seal Kit - 4640525 Valve	2	

SECTION 5 CYLINDERS

# SECTION 5

# CYLINDERS

FIGURE 5-2. LEVELING JACK CYLINDER ASSEMBLY  
(HYDRAULIC JACK OPTION).

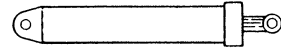

SECTION 5  
CYLINDERS

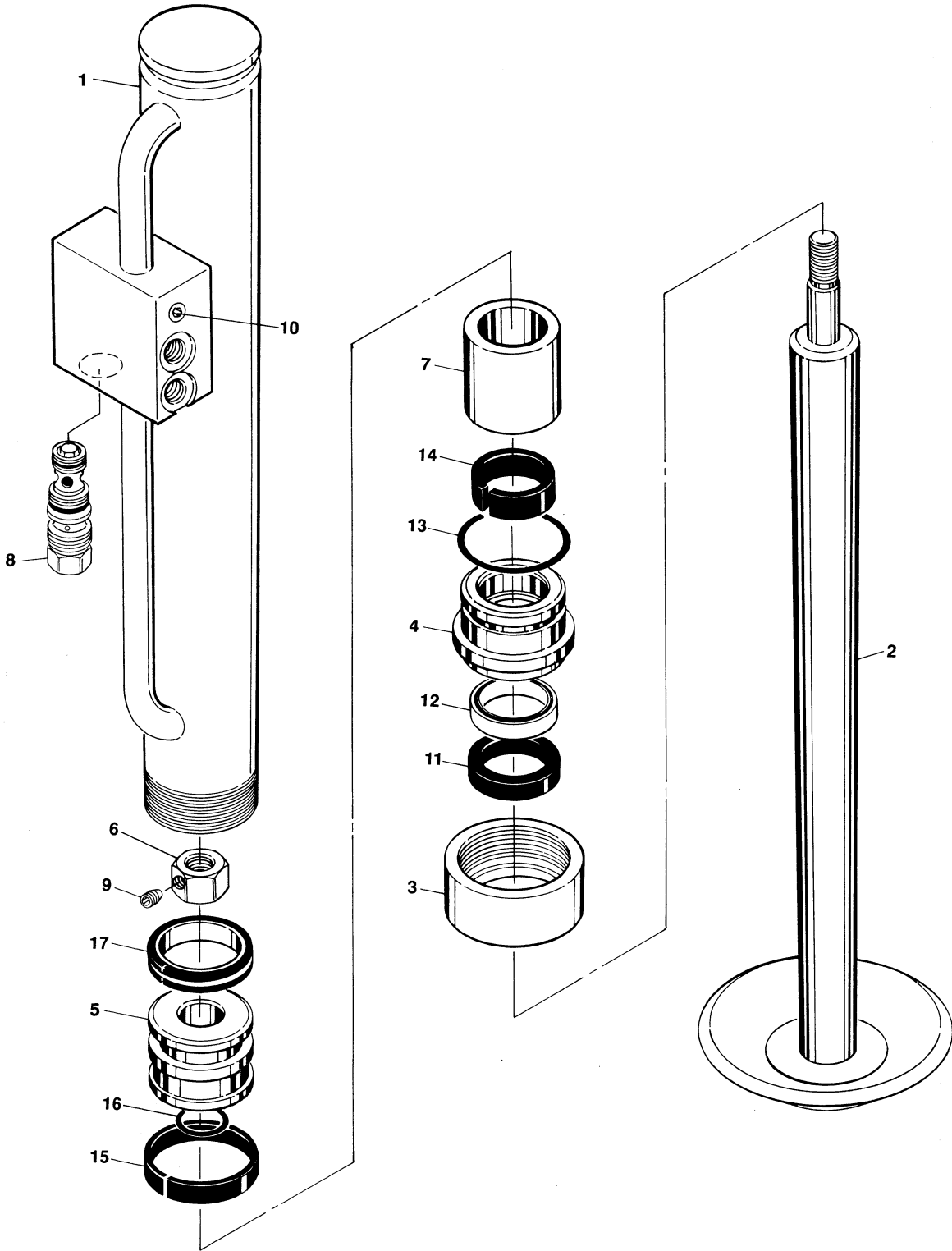

# SECTION 5 CYLINDERS

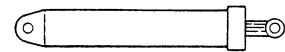

FIGURE & ITEM NO	PART NUMBER	DESCRIPTION	QTY.	REV.
5-2	1682657	<b>LEVELING JACK CYLINDER ASSEMBLY (HYDRAULIC JACK OPTION)</b>	Ref.	A
-1	1682658	Barrel Weldment	1	
-2	1682660	Rod Weldment	1	
-3	1120387	Retainer, Head	1	
-4	1682364	Head	1	
-5	3480123	Piston	1	
-6	3300270	Nut	1	
-7	4565686	Tube, Spacer	1	
-8	4640438	Valve, Cartridge Check	1	
	2900770	Seal Kit - 4640438 Valve	1	
-9	3900170	Setscrew 3/8"-16NC x 3/8"	1	
-10	2200221	Plug, Pipe - 1/8" NPT	1	
-11	Kit	Wiper, Rod	1	
-12	Kit	Seal, Rod	1	
-13	Kit	O-Ring	1	
-14	Kit	Ring, Wear	1	
-15	Kit	Ring, Wear	1	
-16	Kit	O-Ring	1	
-17	Kit	T-Seal	1	
	0100011	Loctite #242	A/R	
	0100038	Primer, Locking	A/R	
	0100035	Loctite #222	A/R	
	0100020	Sealant, Pipe	A/R	
	2901208	Seal Kit (Includes Items 11-17)	1	

SECTION 5 CYLINDERS





# SECTION 5 CYLINDERS

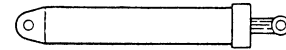

**FIGURE & ITEM NO**    **PART NUMBER**    **DESCRIPTION**    **QTY.**    **REV.**

FIGURE & ITEM NO	PART NUMBER	DESCRIPTION	QTY.	REV.
5-3		<b>LIFT CYLINDER ASSEMBLIES</b>	Ref.	
	1682243	<b>LIFT CYLINDER ASSEMBLY - CM40RT (NOT SHOWN)</b>	Ref.	B
-1	1682080	Barrel Weldment	1	
	0961379	Bushing, Bronze	2	
-2	1682100	Rod Weldment	1	
	0961380	Bushing, Bronze	2	
-3	1120358	Retainer, Head	1	
-4	1682076	Head	1	
-5	4564707	Tube, Spacer	1	
-6	3480137	Piston	1	
-7	3300286	Nut	1	
-8	3900170	Setscrew 3/8"-16NC x 3/8"	1	
-9	Not Used			
-10	Kit	Wiper, Rod	1	
-11	Kit	Seal, Rod	1	
-12	Kit	Ring, Wear	1	
-13	Kit	O-Ring	1	
-14	Kit	O-Ring	1	
-15	Kit	Ring, Wear	1	
-16	Kit	T-Seal	1	
-17	2160002	Fitting, Grease	2	
-18	2180527	Plug, Pipe (Located on Rod End)	1	
	0100011	Loctite #242	A/R	
	0100020	Sealant, Pipe	A/R	
	0100035	Loctite #222	A/R	
	0100038	Primer, Locking	A/R	
	2901116	Seal Kit - CM40RT (Includes Items 10-16)	1	
	1682593	<b>LIFT CYLINDER ASSEMBLY - CM33RT AND CM25RT</b>	Ref.	B
-101	1682594	Barrel Weldment	1	
	0961379	Bushing, Bronze	2	
-102	1682082	Rod Weldment	1	
	0961380	Bushing, Bronze	2	
-103	1120358	Retainer, Head	1	
-104	1682098	Head	1	
-105	4565605	Tube, Spacer	1	
-106	3480137	Piston	1	
-107	3300286	Nut	1	
-108	3900170	Setscrew 3/8"-16NC x 3/8"	1	
-109	Not Used			
-110	Kit	Wiper, Rod	1	
-111	Kit	Seal, Rod	1	
-112	Kit	Ring, Wear	1	
-113	Kit	O-Ring	1	

**SECTION 5 CYLINDERS**



# SECTION 5 CYLINDERS

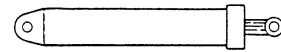
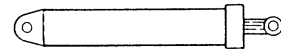

FIGURE & ITEM NO	PART NUMBER	DESCRIPTION	QTY.	REV.
5-3		<b>LIFT CYLINDER ASSEMBLIES (CONTINUED)</b>	Ref.	
-114	Kit	O-Ring	1	
-115	Kit	Ring, Wear	1	
-116	Kit	T-Seal	1	
-117	2160002	Fitting, Grease	2	
	0100011	Loctite #242	A/R	
	0100035	Loctite #222	A/R	
	0100038	Primer, Locking	A/R	
	2901115	Seal Kit - CM33RT and CM25RT (Includes Items 110-116)	1	
	0251791	<b>MANUAL DESCENT VALVE INSTALLATION</b>	Ref.	B
-201	4640699	Valve, Pull	1	
	2900503	Seal Kit - 4640699 Valve	1	
-202	0080190	Adapter	1	
-203	3311402	Nut, Jam 1/4"-20NC	1	
-204	Not Used			
-205	0901767	Bracket, Cable Mounting	1	
-206	3321402	Nut, Jam 1/4"-28NF	4	
-207	4751400	Flatwasher 1/4"	6	
-208	1060377	Cable, Manual Descent	1	
-209	0641416	Bolt 1/4"-20NC x 2"	2	
-210	3311401	Nut 1/4"-20NC	2	
-211	4761400	Lockwasher 1/4"	2	
-212	3760170	Ring	1	
-213	1701437	Decal - Manual Descent	1	
-214	3841127	Rod	1	
-215	3450405	Pin, Cotter 1/8" x 1 1/4"	1	
-216	4220044	Stop, Throttle	1	
		<b>HOLDING VALVE INSTALLATION (STANDARD)</b>	Ref.	
-301	4640382	Cartridge, Holding Valve	1	
	7009742	Coil (Modular Controls Version)	1	
	2900503	Seal Kit (Modular Controls Version)	1	
	7000645	Coil (Hydraforce Version)	1	
	2900800	Seal Kit (Hydraforce Version)	1	
-302	1060016	Cable, Electrical - 16/3	24 ft./7.3m	
	0010421	<b>BELLOWS INSTALLATION (OPTIONAL - NOT SHOWN)</b>	Ref.	
	4060068	Bellows - Lift Cylinder	1	

SECTION 5 CYLINDERS

# SECTION 5 CYLINDERS

FIGURE 5-4. STEER CYLINDER ASSEMBLY.



SECTION 5 CYLINDERS

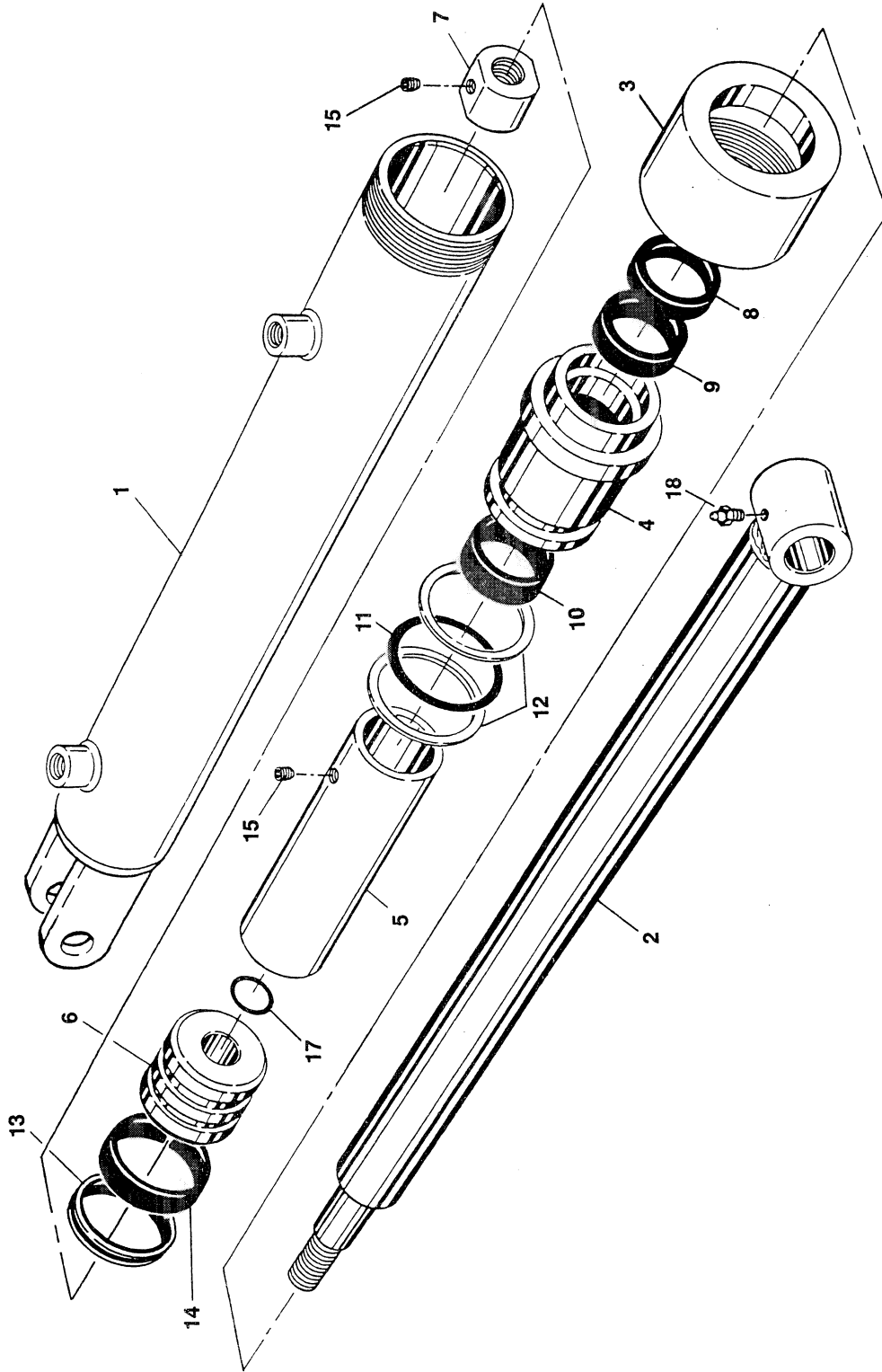

# SECTION 5 CYLINDERS

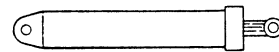

FIGURE & ITEM NO	PART NUMBER	DESCRIPTION	QTY.	REV.
5-4	1681604	STEER CYLINDER ASSEMBLY	Ref.	D
-1	1681607	Barrel Weldment	1	
-2	1681605	Rod Weldment	1	
-3	1120179	Retainer, Head	1	
-4	1680892	Head	1	
-5	4563142	Tube, Spacer	1	
-6	3480120	Piston	1	
-7	3300187	Nut	1	
-8	Kit	Wiper, Rod	1	
-9	Kit	Seal, Rod	1	
-10	Kit	Ring, Wear	1	
-11	Kit	O-Ring	1	
-12	Kit	Ring, Back-up	2	
-13	Kit	T-Seal	1	
-14	Kit	Ring, Wear	1	
-15	3300141	Setscrew 1/4"-20NC x 5/8"	3	
-16	Not Used			
-17	Kit	O-Ring	1	
-18	2160002	Fitting, Grease	1	
	0100011	Loctite #242	A/R	
	2901119	Seal Kit (Includes Items 8-14 and 17)	1	

SECTION 5 CYLINDERS

# SECTION 5

# CYLINDERS

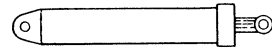
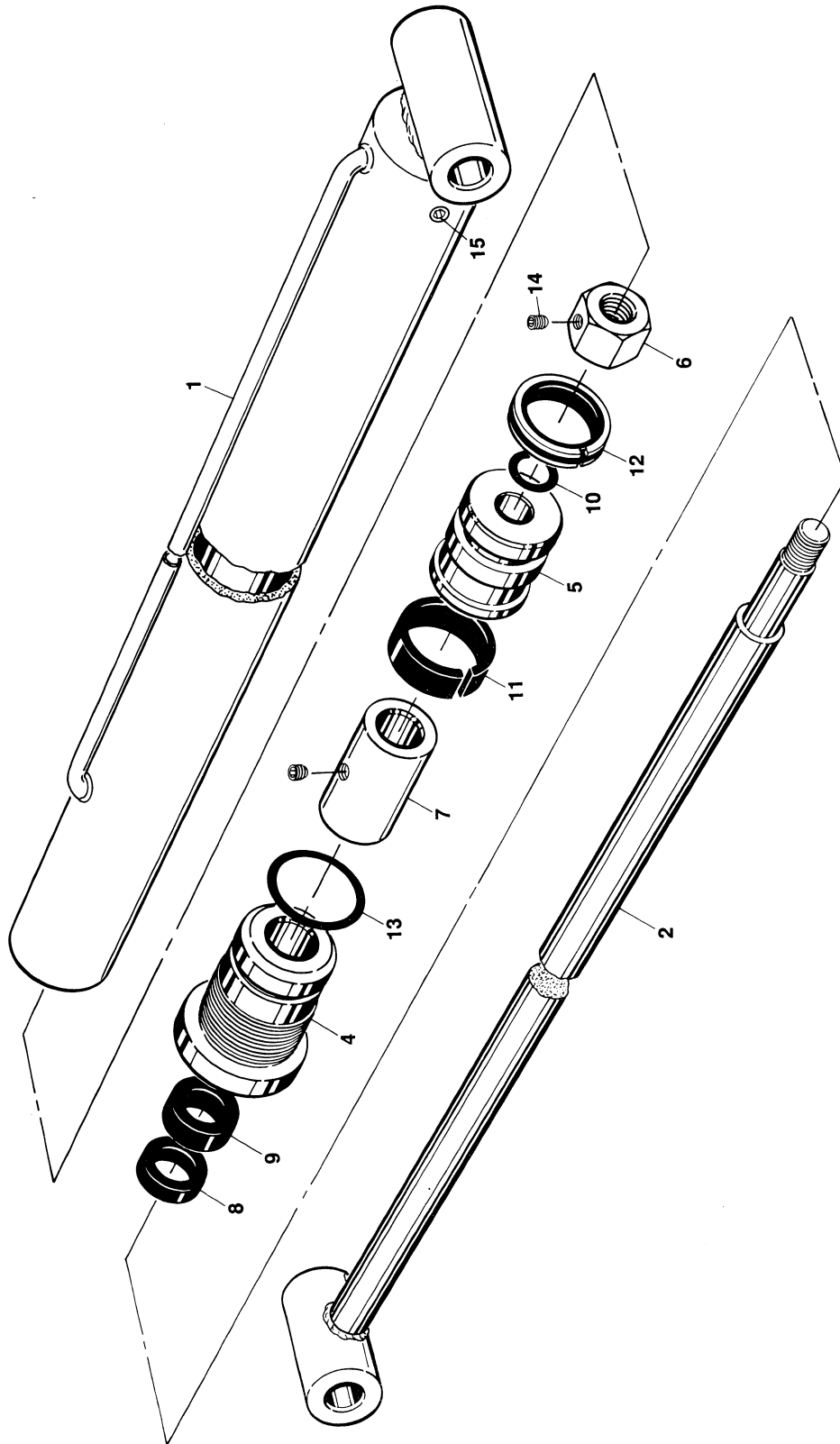

FIGURE 5-5. TRAVERSING PLATFORM EXTENSION CYLINDER ASSEMBLY (TRAVERSING PLATFORM OPTION).

SECTION 5  
CYLINDERS



# SECTION 5

# CYLINDERS

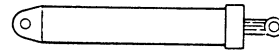

FIGURE & ITEM NO	PART NUMBER	DESCRIPTION	QTY.	REV.
5-5	1681591	<b>TRAVERSING PLATFORM EXTENSION CYLINDER ASSEMBLY (TRAVERSING PLATFORM OPTION)</b>	Ref.	C
-1	1681594	Barrel Weldment	1	
-2	1681593	Rod Weldment	1	
-3	Not Used			
-4	1681402	Head	1	
-5	3480123	Piston	1	
-6	3300270	Nut	1	
-7	4562720	Tube, Spacer	1	
-8	Kit	Wiper, Rod	1	
-9	Kit	Seal, Rod	1	
-10	Kit	O-Ring	1	
-11	Kit	Ring, Wear	1	
-12	Kit	Seal, Piston	1	
-13	Kit	O-Ring	1	
-14	3900170	Setscrew 3/8"-16NC	1	
-15	2200202	Plug, Pipe - 1/4" NPT	4	
	0100011	Loctite #242	A/R	
	0100020	Sealant, Pipe	A/R	
	0100035	Loctite #222	A/R	
	0100038	Primer, Locking	A/R	
	2901121	Seal Kit (Includes Items 8-13)	1	

SECTION 5 CYLINDERS







**TABLE OF CONTENTS**

<b>FIGURE NO.</b>	<b>DESCRIPTION</b>	<b>PAGE NO.</b>
6-1	Hydraulic Diagram - Manual Descent/Emergency Lowering .....	6-2
6-2	Hydraulic Diagram - Oscillating Axle (Optional) .....	6-4
6-3	Hydraulic Diagram - Overload/Tilt (French Spec) .....	6-6
6-4	Hydraulic Diagram - Standard (Electric Machines) .....	6-8
6-5	Hydraulic Diagram - Standard (2WD) .....	6-12
6-6	Hydraulic Diagram - Standard (4WD) .....	6-16
6-7	Hydraulic Diagram List - Complete .....	6-21

# SECTION 6 HYDRAULICS

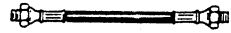
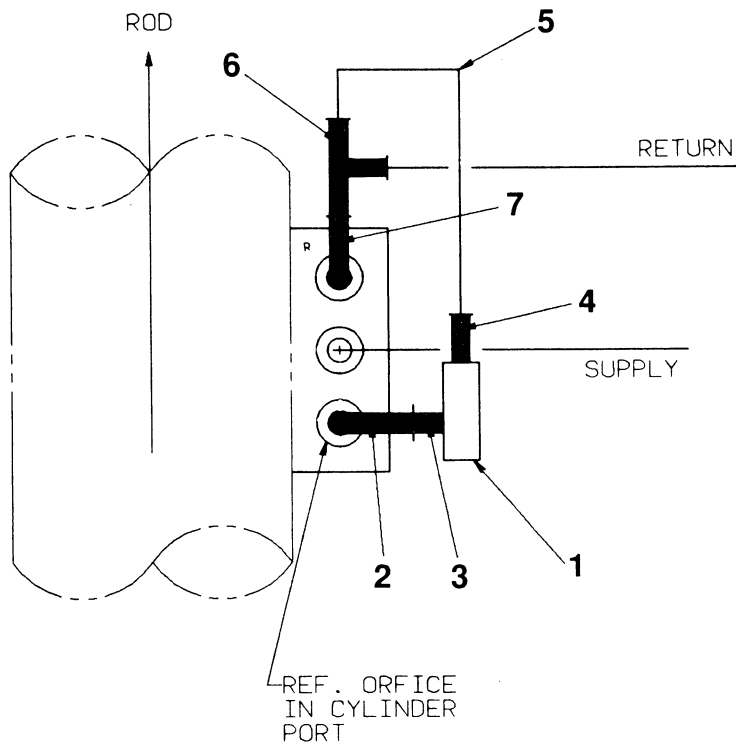

FIGURE 6-1. HYDRAULIC DIAGRAM - MANUAL DESCENT/EMERGENCY LOWERING (OPTIONAL).



SECTION 6 HYDRAULICS

# SECTION 6      HYDRAULICS

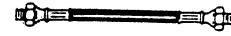

FIGURE & ITEM NO	PART NUMBER	DESCRIPTION	QTY.	REV.
6—1	0251791	<b>HYDRAULIC DIAGRAM - MANUAL DESCENT/EMERGENCY LOWERING</b>	Ref.	B
—1	4640699	Valve, Pull	1	
	2900503	Seal Kit (4640699 Valve)	1	
—2	2220111	Fitting, 90°	1	
—3	2220820	Fitting, 90°	1	
—4	2220399	Fitting, Adaptor	1	
—5	4565177	Tube	1	
—6	2220635	Fitting, Tee	1	
—7	2220473	Fitting, 90°	1	

**SECTION 6 HYDRAULICS**

# SECTION 6 HYDRAULICS

FIGURE 6-2. HYDRAULIC DIAGRAM - OSCILLATING AXLE (OPTIONAL).



SECTION 6 HYDRAULICS

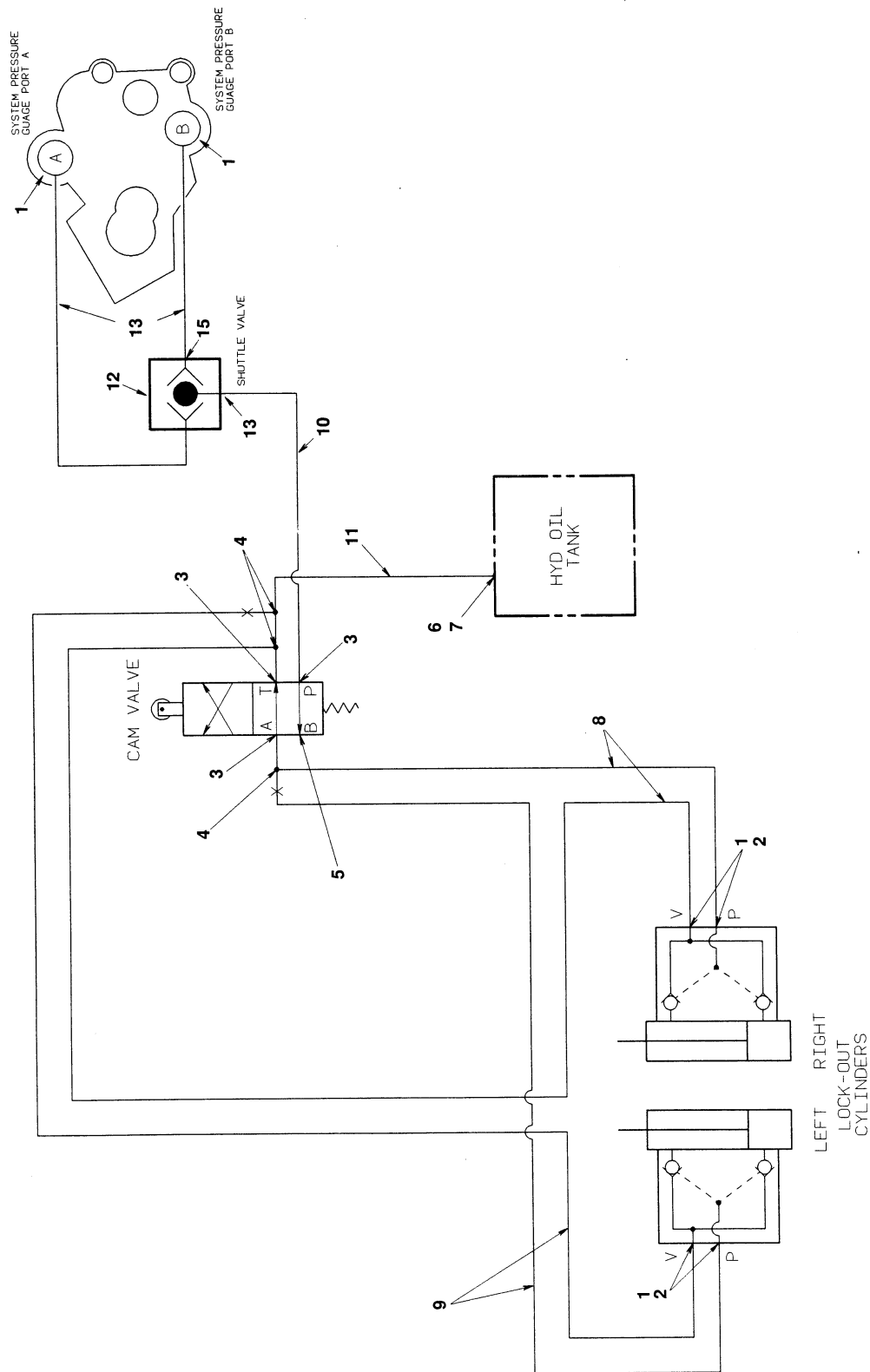

# SECTION 6

# HYDRAULICS



FIGURE & ITEM NO	PART NUMBER	DESCRIPTION	QTY.	REV.
6—2	2791901	HYDRAULIC DIAGRAM - OSCILLATING AXLE (OPTIONAL)	Ref.	—
—1	2220582	Fitting, Straight	6	
—2	2220462	Fitting, 90°	4	
—3	2220466	Fitting, 90°	3	
—4	2220605	Fitting, Tee	3	
—5	2220235	Fitting, Plug	1	
—6	2220385	Fitting, Tee	1	
—7	2220618	Fitting, Reducer	1	
—8	2752011	Hose	2	
—9	2751396	Hose	2	
—10	2750897	Hose	1	
—11	2750895	Hose	1	
—12	4640013	Valve, Shuttle	1	
—13	2220414	Fitting, Straight	1	
—14	2751424	Hose	2	
—15	2220416	Fitting, 90°	2	
	0100020	----- Sealant, Pipe	A/R	

SECTION 6 HYDRAULICS

# SECTION 6 HYDRAULICS

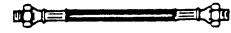
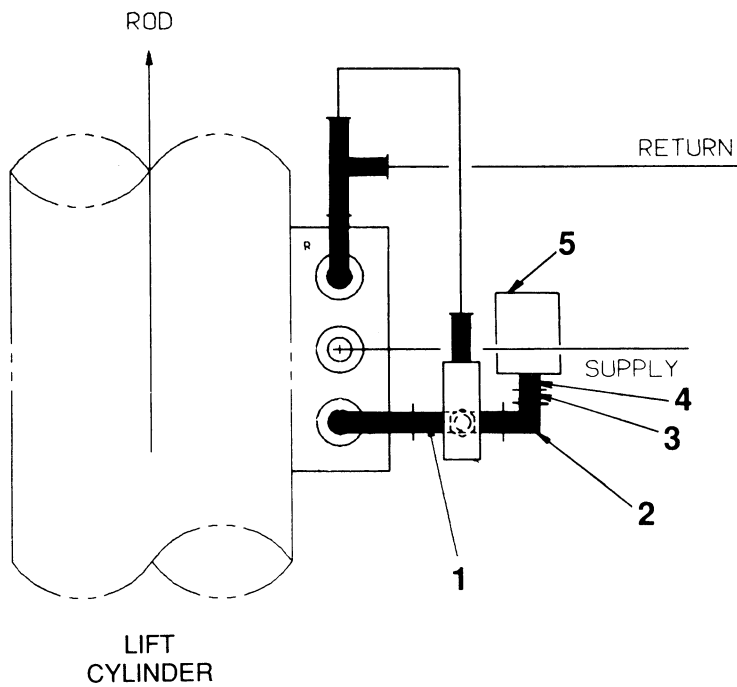

FIGURE 6-3. HYDRAULIC DIAGRAM - OVERLOAD/TILT INTERLOCK  
(FRENCH SPEC ONLY - BUILT AFTER SEPTEMBER 1991).



SECTION 6 HYDRAULICS

# SECTION 6      HYDRAULICS

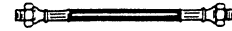

FIGURE & ITEM NO	PART NUMBER	DESCRIPTION	QTY.	REV.
6—3	0252366	HYDRAULIC DIAGRAM - OVERLOAD/TILT INTERLOCK (FRENCH SPEC ONLY)	Ref.	A
—1	2220752	Fitting, Tee	1	
—2	2220820	Fitting, 90°	1	
—3	2220880	Fitting, Straight	1	
—4	2220440	Fitting, Straight	1	
—5	1692617	Switch, Pressure	1	
	4460428	Connector, Strain Relief (Not Shown)	1	

SECTION 6  
HYDRAULICS





# SECTION 6      HYDRAULICS

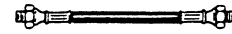

FIGURE & ITEM NO	PART NUMBER	DESCRIPTION	QTY.	REV.
6-4	2791690	HYDRAULIC DIAGRAM - STANDARD (ELECTRIC MACHINES)	Ref.	G
-1	4564672	Tube	1	
-2	4564673	Tube	1	
-3	4564674	Tube	1	
-4	4564675	Tube	1	
-5	4564676	Tube	1	
-6	4564677	Tube	1	
-7	4564678	Tube	1	
-8	4564679	Tube	1	
-9	4564680	Tube	1	
-10	4564698	Tube	1	
-11	4564699	Tube	1	
-12	2720295	Hose, Suction (60"/1.53m Length)	1	
-13	2220669	Fitting, Split Flange Kit	1	
-14	2210060	Fitting, 90° Split Flange	1	
-15	1320033	Clamp	8	
-16	2750777	Hose	1	
-17	2220600	Fitting, Straight	2	
-18	2180679	Orifice	1	
-19	Not Used			
-20	2180745	Fitting, Modified	1	
-21	2220345	Fitting, Straight	1	
-22	2220275	Fitting, Reducer	1	
-23	2220403	Fitting, 90°	1	
-24	2210003	Fitting, Nipple	2	
-25	2720355	Hose, Suction (11 1/2"/29.2cm Length)	1	
-26	2220832	Fitting, 4-Way	1	
-27	2220596	Fitting, 90°	3	
-28	2220621	Fitting, Reducer	1	
-29	2220507	Fitting, 90°	1	
-30	Not Used			
-31	2220835	Fitting, Union	2	
-32	2750970	Hose	2	
-33	4640009	Valve, Check	1	
-34	2220452	Fitting	1	
-35	2220700	Fitting, Tee	2	
-36	2220679	Fitting, Tee	1	
-37	2220408	Fitting, Straight	1	
-38	2220374	Fitting, Straight	1	
-39	2220385	Fitting, Tee	2	
-40	2220651	Fitting, Swivel	1	
-41	2180750	Fitting, Tee	1	
-42	2220373	Fitting, Straight	5	
-43	2220422	Fitting	1	
-44	2220417	Fitting, Straight	2	
-45	2750896	Hose	2	
-46	2220468	Fitting, Straight	2	
-47	2220238	Fitting, Plug	2	

SECTION 6 HYDRAULICS



# SECTION 6

# HYDRAULICS

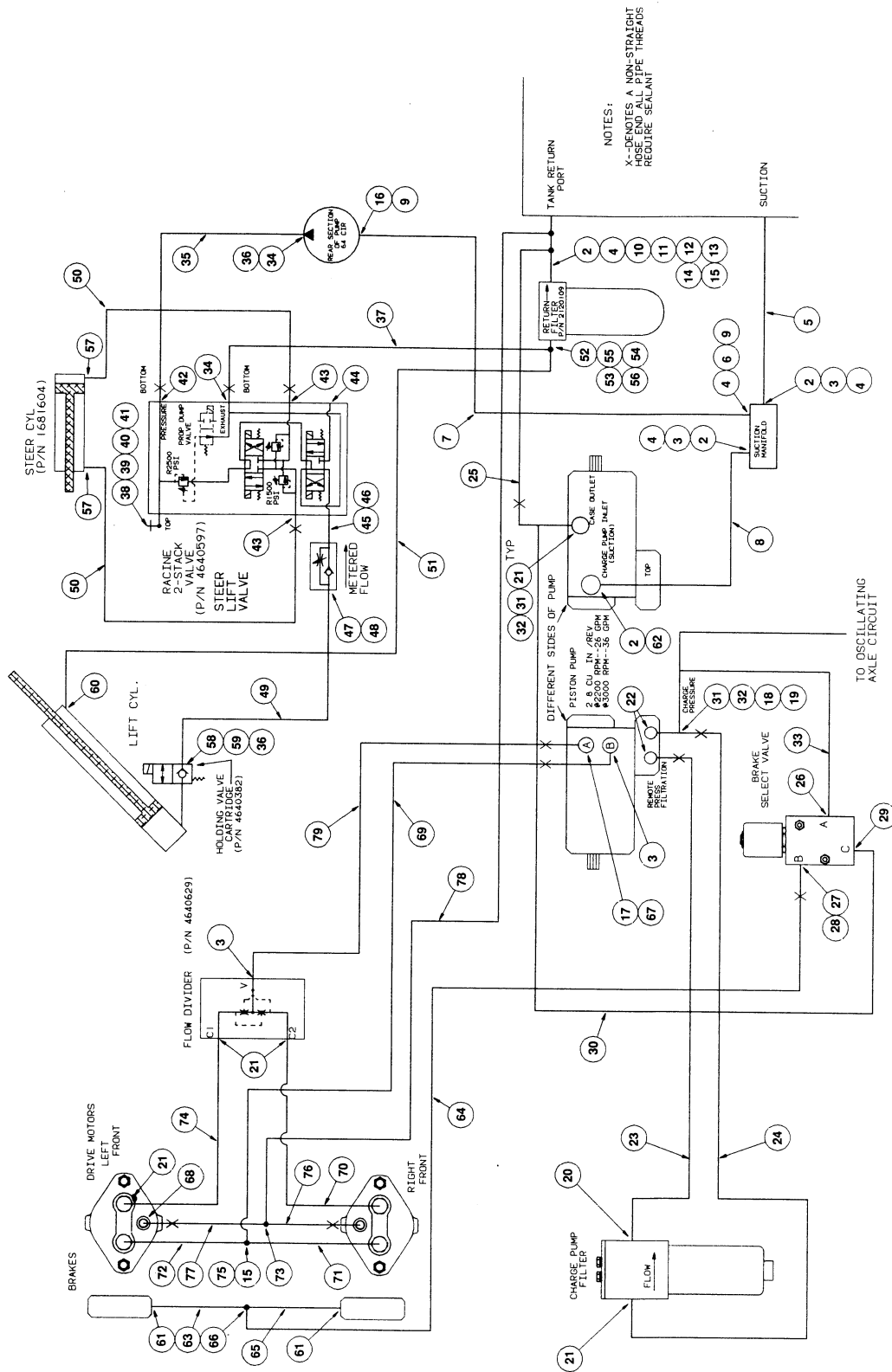

FIGURE & ITEM NO	PART NUMBER	DESCRIPTION	QTY.	REV.
6-4	2791690	<b>HYDRAULIC DIAGRAM - STANDARD (ELECTRIC MACHINES) (CONTINUED)</b>	Ref.	G
-48	2220113	Fitting, 90°	1	
-49	22220593	Fitting, Straight	3	
-50	4640382	Valve, Cartridge	1	
-51	2220383	Fitting, Tee	1	
-52	2220280	Fitting, Straight	1	
-53	4640216	Valve, Colorflow	1	
-54	2220580	Fitting, 90°	1	
-55	2220796	Fitting, 90°	1	
-56	2220386	Fitting, 90°	2	
-57	2220473	Fitting, 90°	1	
-58	2750930	Hose	1	
-59	2751123	Hose	1	
-60	2751466	Hose	2	
-61	2180746	Fitting, Modified	1	
-62	2220261	Fitting, Coupling	2	
-63	2220428	Fitting, Quick Disconnect	3	
-64	2220429	Cap, Dust	3	
-65	2220415	Fitting	4	
-66	2751026	Hose	1	
-67	2220250	Fitting, Reducer	3	
-68	2220584	Fitting, Tee	1	
-69	2220673	Fitting, 90°	1	
-70	4640197	Valve, Check	1	
-71	2220414	Fitting, Straight	1	
-72	2750760	Hose	1	
-73	2751021	Hose	2	
-74	2220822	Fitting, Orifice	1	
-75	2750900	Hose	1	
-76	2751391	Hose	1	
-77	2751010	Hose	1	
-78	2220711	Fitting, Tee	1	
-79	2220752	Fitting, Tee	1	
-80	2220684	Fitting, Tee	2	
-81	2751514	Hose	2	
-82	2750972	Hose	1	
-83	2750757	Hose	1	
-84	2750979	Hose	1	
-85	2750791	Hose	1	
-86	2220469	Fitting, 4 Way	1	
-87	2220618	Fitting, Reducer	1	
-88	2220366	Fitting, 90°	2	
-89	2220375	Fitting	7	
-90	2220567	Fitting, 90°	1	
-91	2220567	Fitting, 90°	1	
-92	2220585	Fitting, 90°	1	
-93	2220696	Fitting, Reducer	1	
-94	2180491	Fitting, Modified	1	

SECTION 6 HYDRAULICS

# SECTION 6 HYDRAULICS

FIGURE 6-5. HYDRAULIC DIAGRAM - STANDARD (2WD).



# SECTION 6

# HYDRAULICS

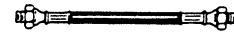

FIGURE & ITEM NO	PART NUMBER	DESCRIPTION	QTY.	REV.
6—5		HYDRAULIC DIAGRAM - STANDARD (2WD)	Ref.	
	2791904	HYDRAULIC DIAGRAM - STANDARD 2WD	Ref.	B
—1	Not Used			
—2	2210003	Fitting, Swivel	4	
—3	2220377	Fitting, Straight	3	
—4	1320033	Clamp, Hose	16	
—5	2720372	Hose, Suction 1" (2.5cm) x 7" (17.8 cm)	1	
—6	2220435	Fitting, Straight	1	
—7	2720375	Hose, Suction 3/4" (1.9cm) x 49" (1.25m)	1	
—8	2720374	Hose, Suction 1" (2.54cm) x 49" (1.25m)	1	
—9	2210005	Fitting, Swivel	2	
—10	2720373	Hose, Suction 1" (2.54cm) x 8 3/4" (20cm)	1	
—11	2220403	Fitting, 90°	1	
—12	2180745	Fitting, Modified	1	
—13	2220642	Fitting, Tee	1	
—14	2220275	Fitting, Reducer	1	
—15	2220710	Fitting, Reducer	3	
—16	2220498	Fitting, 45°	1	
—17	2220646	Fitting, 90°	1	
—18	2220609	Fitting, Reducer	1	
—19	2220606	Fitting, Tee	1	
—20	2220578	Fitting, 90°	1	
—21	2220451	Fitting, Straight	7	
—22	2220408	Fitting, Straight	2	
—23	2750837	Hose	1	
—24	2751614	Hose	1	
—25	2751321	Hose	1	
—26	2220495	Fitting, 90°	1	
—27	2220250	Fitting, Reducer	1	
—28	2220584	Fitting, Tee	1	
—29	2220343	Fitting, Straight	1	
—30	2750778	Hose	1	
—31	2220700	Fitting, Tee	1	
—32	2220621	Fitting, Reducer	1	
—33	2750918	Hose	1	
—34	2220373	Fitting, Straight	2	
—35	2750759	Hose	1	
—36	2220386	Fitting, 90°	2	
—37	2750968	Hose	1	
—38	2220446	Fitting, Reducer	1	
—39	2220438	Fitting, Nipple	1	
—40	2220428	Fitting, Coupling	1	
—41	2220429	Cap, Dust	1	
—42	2220600	Fitting, Straight	1	
—43	2220468	Fitting, Straight	2	
—44	2220238	Plug	1	
—45	2220113	Fitting, 90°	1	

SECTION 6 HYDRAULICS



# SECTION 6

# HYDRAULICS

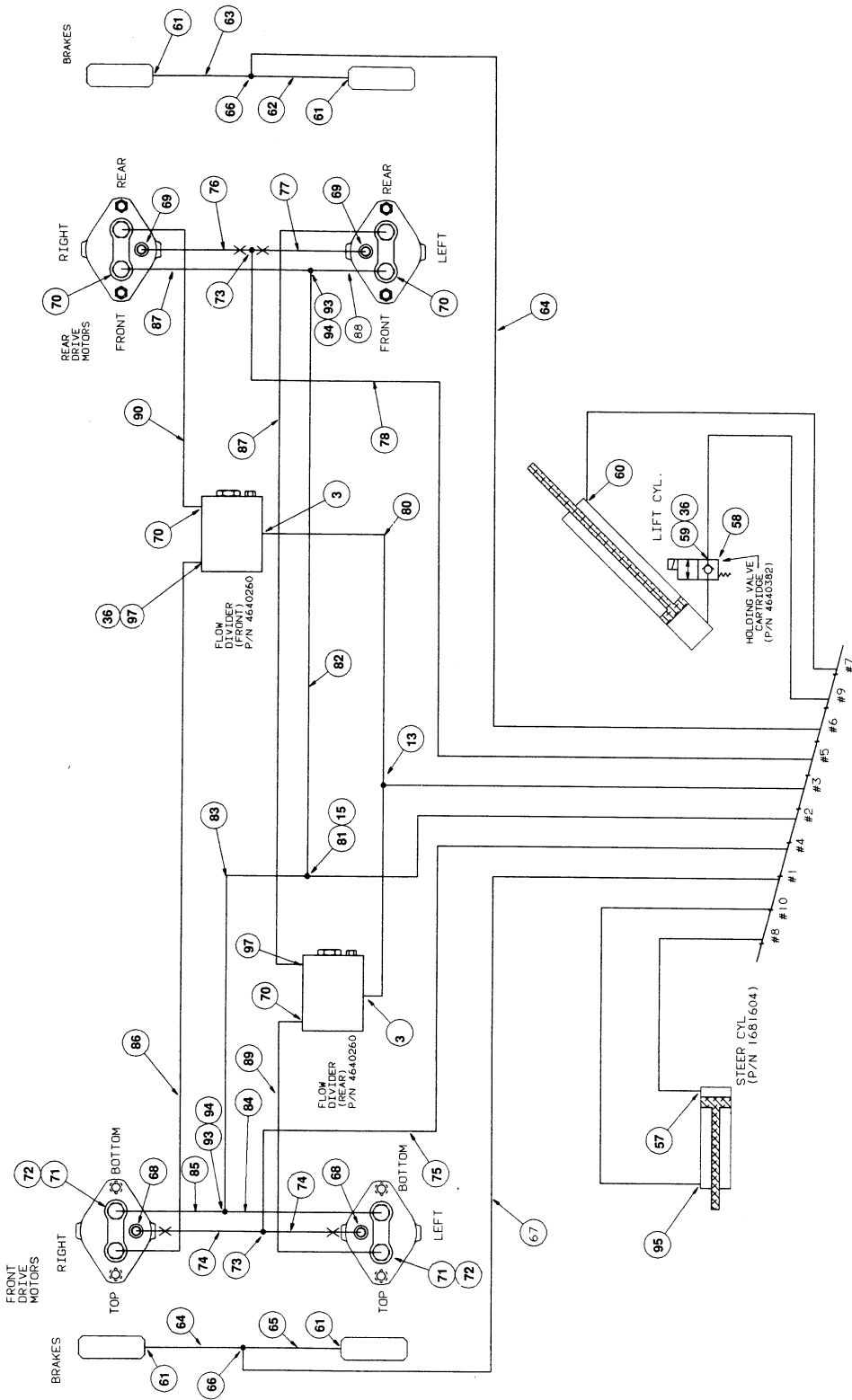

FIGURE & ITEM NO	PART NUMBER	DESCRIPTION	QTY.	REV.
6-5		HYDRAULIC DIAGRAM - STANDARD (2WD) (CONTINUED)	Ref.	
	2791904	HYDRAULIC DIAGRAM - STANDARD 2WD (CONTINUED)	Ref.	B
-46	2220280	Fitting, Nipple	1	
-47	4640216	Valve, Adjustable Colorflow	1	
-48	2220580	Fitting, 90°	1	
-49	2750930	Hose	1	
-50	2750896	Hose	1	
-51	2751123	Hose	1	
-52	2220696	Fitting, Reducer	1	
-53	2220282	Fitting, Reducer	1	
-54	2220679	Fitting, Tee	1	
-55	2220619	Fitting, Reducer	1	
-56	2220507	Fitting, 90°	1	
-57	2220417	Fitting, Straight	2	
-58	4640382	Valve, Cartridge	1	
	7009742	Coil (Modular Controls Version)	1	
	2900503	Seal Kit (Modular Controls Version)	1	
	7000645	Coil (Hydraforce Version)	1	
	2900800	Seal Kit (Hydraforce Version)	1	
-59	2220796	Fitting, 90°	1	
-60	2220473	Fitting, 90°	1	
-61	2220415	Fitting, Straight	2	
-62	2220365	Fitting, 45°	1	
-63	2751010	Hose	1	
-64	2751410	Hose	1	
-65	2750892	Hose	1	
-66	2220504	Fitting, Tee	1	
-67	2220404	Fitting, 90°	1	
-68	2220371	Fitting, 90°	2	
-69	2752334	Hose	1	
-70	2752237	Hose	1	
-71	2752249	Hose	1	
-72	2752239	Hose	1	
-73	2220490	Fitting, Tee	1	
-74	2752242	Hose	1	
-75	2220363	Fitting, Tee	1	
-76	2751003	Hose	1	
-77	2750919	Hose	1	
-78	2751110	Hose	1	
-79	2752330	Hose	1	

# SECTION 6 HYDRAULICS

# SECTION 6 HYDRAULICS

FIGURE 6-6. HYDRAULIC DIAGRAM - STANDARD (4WD)  
(SHEET 2 OF 2).



SECTION 6 HYDRAULICS





# SECTION 6

# HYDRAULICS

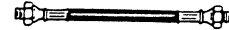

SECTION 6 HYDRAULICS

FIGURE & ITEM NO	PART NUMBER	DESCRIPTION	QTY.	REV.
6-6		HYDRAULIC DIAGRAM - STANDARD (4WD)	Ref.	
	2791891	HYDRAULIC DIAGRAM - STANDARD 4WD	Ref.	E
-1	Not Used			
-2	2210003	Fitting, Swivel	4	
-3	2220377	Fitting, Straight	5	
-4	1320033	Clamp, Hose	16	
-5	2720372	Hose, Suction 1" (2.5cm) x 7" (17.8 cm)	1	
-6	2220435	Fitting, Straight	1	
-7	2720375	Hose, Suction 3/4" (1.9cm) x 46" (1.17m)	1	
-8	2720374	Hose, Suction 1" (2.54cm) x 46" (1.17m)	1	
-9	2210005	Fitting, Swivel	2	
-10	2720373	Hose, Suction 1" (2.54cm) x 8 3/4" (20cm)	1	
-11	2220403	Fitting, 90°	1	
-12	Not Used			
-13	2220642	Fitting, Tee	2	
-14	2220275	Fitting, Reducer	1	
-15	2220710	Fitting, Reducer	3	
-16	2220498	Fitting, 45°	1	
-17	2220365	Fitting	2	
-18	2220609	Fitting, Reducer	1	
-19	2220635	Fitting, Tee	1	
-20	2220578	Fitting, 90°	1	
-21	2220451	Fitting, Straight	2	
-22	2220408	Fitting, Straight	2	
-23	2750837	Hose	1	
-24	2751614	Hose	1	
-25	2751321	Hose	1	
-26	2220495	Fitting, 90°	1	
-27	2220250	Fitting, Reducer	1	
-28	2220584	Fitting, Tee	1	
-29	2220343	Fitting, Straight	1	
-30	2750778	Hose	1	
-31	2220700	Fitting, Tee	4	
-32	2220621	Fitting, Reducer	2	
-33	2750918	Hose	1	
-34	2220373	Fitting, Straight	2	
-35	2750759	Hose	1	
-36	2220386	Fitting, 90°	3	
-37	2750968	Hose	1	
-38	2220446	Fitting, Reducer	1	
-39	2220438	Fitting, Nipple	1	
-40	2220428	Fitting, Coupling	1	
-41	2220429	Cap, Dust	1	
-42	2220600	Fitting, Straight	1	
-43	2220468	Fitting, Straight	2	
-44	2220238	Plug	1	
-45	2220113	Fitting, 90°	1	

# SECTION 6

# HYDRAULICS



FIGURE & ITEM NO	PART NUMBER	DESCRIPTION	QTY.	REV.
6-6		HYDRAULIC DIAGRAM - STANDARD (4WD) (CONTINUED)	Ref.	
	2791891	HYDRAULIC DIAGRAM - STANDARD 4WD (CONTINUED)	Ref.	E
-46	2220280	Fitting, Nipple	1	
-47	4640216	Valve, Adjustable Colorflow	1	
-48	2220580	Fitting, 90°	1	
-49	2750930	Hose	1	
-50	2750896	Hose	2	
-51	2751123	Hose	1	
-52	2220696	Fitting, Reducer	1	
-53	2220282	Fitting, Reducer	5	
-54	2220679	Fitting, Tee	1	
-55	2220619	Fitting, Reducer	1	
-56	2220507	Fitting, 90°	1	
-57	2220417	Fitting, Straight	1	
-58	4640382	Valve, Cartridge	1	
	7009742	Coil (Modular Controls Version)	1	
	2900503	Seal Kit (Modular Controls Version)	1	
	7000645	Coil (Hydraforce Version)	1	
	2900800	Seal Kit (Hydraforce Version)	1	
-59	2220796	Fitting, 90°	1	
-60	2220473	Fitting, 90°	1	
-61	2220415	Fitting, Straight	4	
-62	2751391	Hose	1	
-63	2751412	Hose	1	
-64	2751410	Hose	2	
-65	2750892	Hose	1	
-66	2220504	Fitting, Tee	2	
-67	2750756	Hose	1	
-68	2220628	Fitting, 90°	2	
-69	2220372	Fitting, Straight	2	
-70	2220375	Fitting, Straight	7	
-71	2220811	Fitting, Reducer	4	
-72	2220892	Fitting, Swivel	4	
-73	2220490	Fitting, Tee	2	
-74	2750909	Hose	2	
-75	2751155	Hose	1	
-76	2750997	Hose	1	
-77	2750913	Hose	1	
-78	2751110	Hose	1	
-79	2752330	Hose	2	
-80	2752324	Hose	1	
-81	2220363	Fitting, Tee	1	
-82	2752238	Hose	1	
-83	2752241	Hose	1	
-84	2752378	Hose	1	
-85	2752379	Hose	1	

# SECTION 6 HYDRAULICS

# SECTION 6      HYDRAULICS



FIGURE & ITEM NO	PART NUMBER	DESCRIPTION	QTY.	REV.
6-6		HYDRAULIC DIAGRAM - STANDARD (4WD) (CONTINUED)	Ref.	
	2791891	HYDRAULIC DIAGRAM - STANDARD 4WD (CONTINUED)	Ref.	E
-86	2752380	Hose	1	
-87	2752381	Hose	2	
-88	2752382	Hose	1	
-89	2752383	Hose	1	
-90	2752384	Hose	1	
-91	Not used			
-92	Not Used			
-93	2220481	Fitting, Tee	2	
-94	2220622	Fitting, Reducer	4	
-95	2220585	Fitting, 90°	1	
-96	2210003	Fitting, Nipple	1	
-97	2220360	Fitting, 90°	2	

SECTION 6 HYDRAULICS

# SECTION 6 HYDRAULICS



FIGURE & ITEM NO	PART NUMBER	DESCRIPTION	QTY.	REV.
6-7		<b>HYDRAULIC DIAGRAM LIST - COMPLETE</b>	Ref.	
		<b>Note: Hydraulic Diagrams shown are indicated by an asterisk (*). Hydraulic Diagrams not shown are available from JLG Service Department.</b>		
	2791559	Hydraulic Diagram - Leveling Jacks (Optional)	Ref.	
	0251791*	Hydraulic Diagram - Manual Descent (See Figure 6-1)	Ref.	
	2791903*	Hydraulic Diagram - Oscillating Axle (Optional) (See Figure 6-2)	Ref.	
	0252366*	Hydraulic Diagram - Overload/Tilt Interlock (French Specs) (See Figure 6-3)	Ref.	
	2791690*	Hydraulic Diagram - Standard (Electric Machines) (See Figure 6-4)	Ref.	
	2791904*	Hydraulic Diagram - Standard (Gas and Diesel 2WD Machines) (See Figure 6-5)	Ref.	
	2791891*	Hydraulic Diagram - Standard (Gas and Diesel 4WD) (See Figure 6-6)	Ref.	
	1281563	Hydraulic Diagram - Traversing Platform Without Leveling Jacks (Dwg. Only)	Ref.	
	3510336	Hydraulic Diagram - Traversing Platform Without Leveling Jacks (CM40RT) (B/M Only)	Ref.	
	3510335	Hydraulic Diagram - Traversing Platform Without Leveling Jacks (CM33RT) (B/M Only)	Ref.	
	3510334	Hydraulic Diagram - Traversing Platform Without Leveling Jacks (CM25RT) (B/M Only)	Ref.	
	1281610	Hydraulic Diagram - Traversing Platform With Leveling Jacks (Dwg. Only)	Ref.	
	3510341	Hydraulic Diagram - Traversing Platform With Leveling Jacks (CM40RT) (B/M Only)	Ref.	
	3510340	Hydraulic Diagram - Traversing Platform With Leveling Jacks (CM33RT) (B/M Only)	Ref.	
	3510339	Hydraulic Diagram - Traversing Platform With Leveling Jacks (CM25RT) (B/M Only)	Ref.	

SECTION 6 HYDRAULICS



**SECTION 7****ELECTRICAL****TABLE OF CONTENTS**

<b>FIGURE NO.</b>	<b>DESCRIPTION</b>	<b>PAGE NO.</b>
7-1	Wiring Diagram - Dual Fuel (Ford) . . . . .	7-2
7-2	Wiring Diagram - 110V Generator (Ford) . . . . .	7-3
7-3	Wiring Diagram - 110V Generator (Deutz) . . . . .	7-4
7-4	Wiring Diagram - Overload/Tilt Interlock (French Spec) . . . . .	7-5
7-5	Wiring Diagram - Platform (Diesel Machines) . . . . .	7-6
7-6	Wiring Diagram - Platform (Gas Machines) . . . . .	7-7
7-7	Wiring Diagram - Platform (Electric Machines) . . . . .	7-9
7-8	Wiring Diagram - Standard (Ford Gas Machines) . . . . .	7-10
7-9	Wiring Diagram - Standard (Deutz Diesel Machines) . . . . .	7-11
7-10	Wiring Diagram - Standard (Electric Machines) . . . . .	7-12
7-11	Electrical Components and Wiring Diagram List . . . . .	7-13

# SECTION 7 ELECTRICAL

FIGURE 7-1. DUAL FUEL WIRING DIAGRAM - FORD.

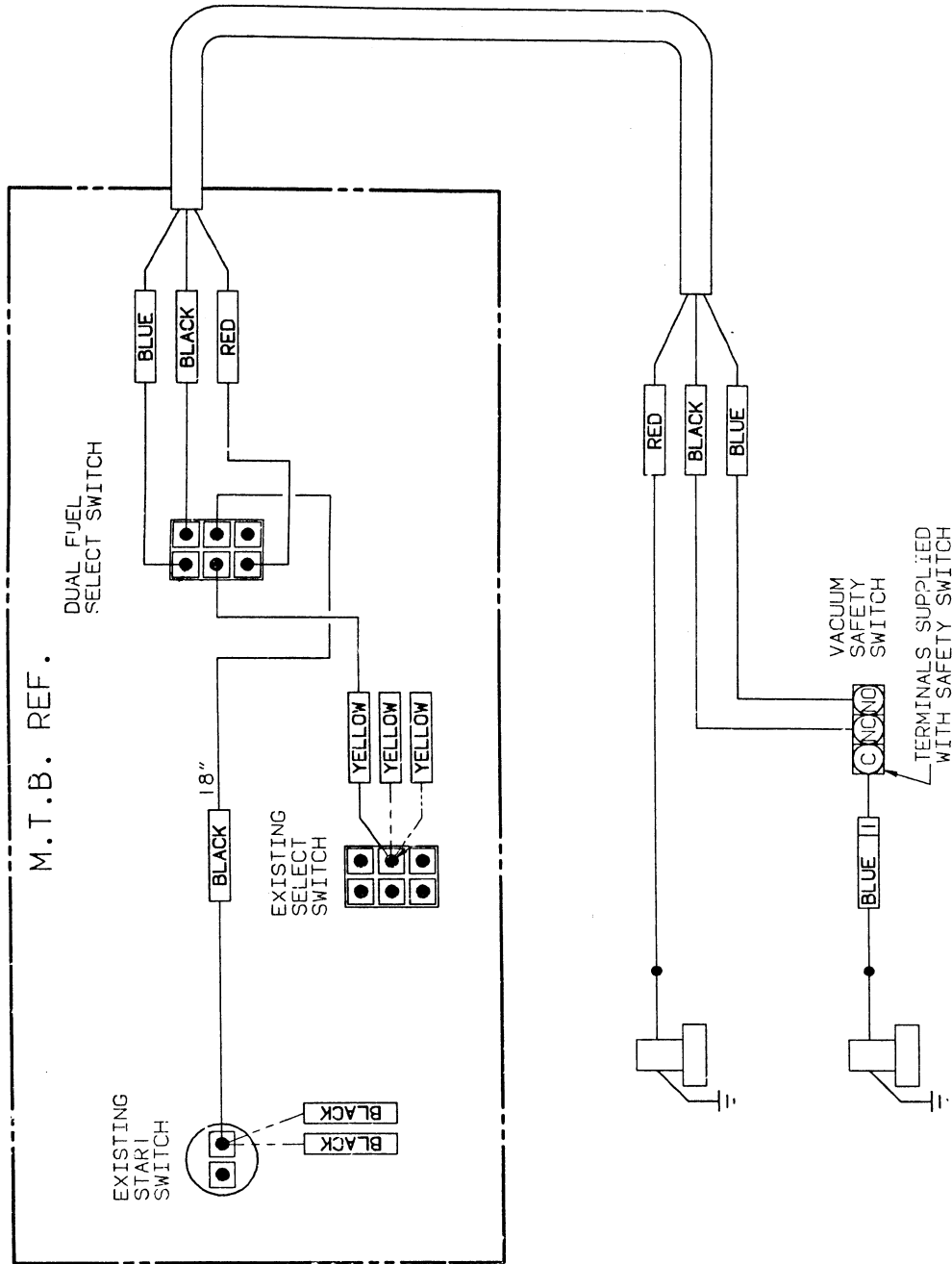

SECTION 7 ELECTRICAL

1281738 G



# SECTION 7 ELECTRICAL

FIGURE 7-2. GENERATOR WIRING DIAGRAM - 110 VOLT (FORD).

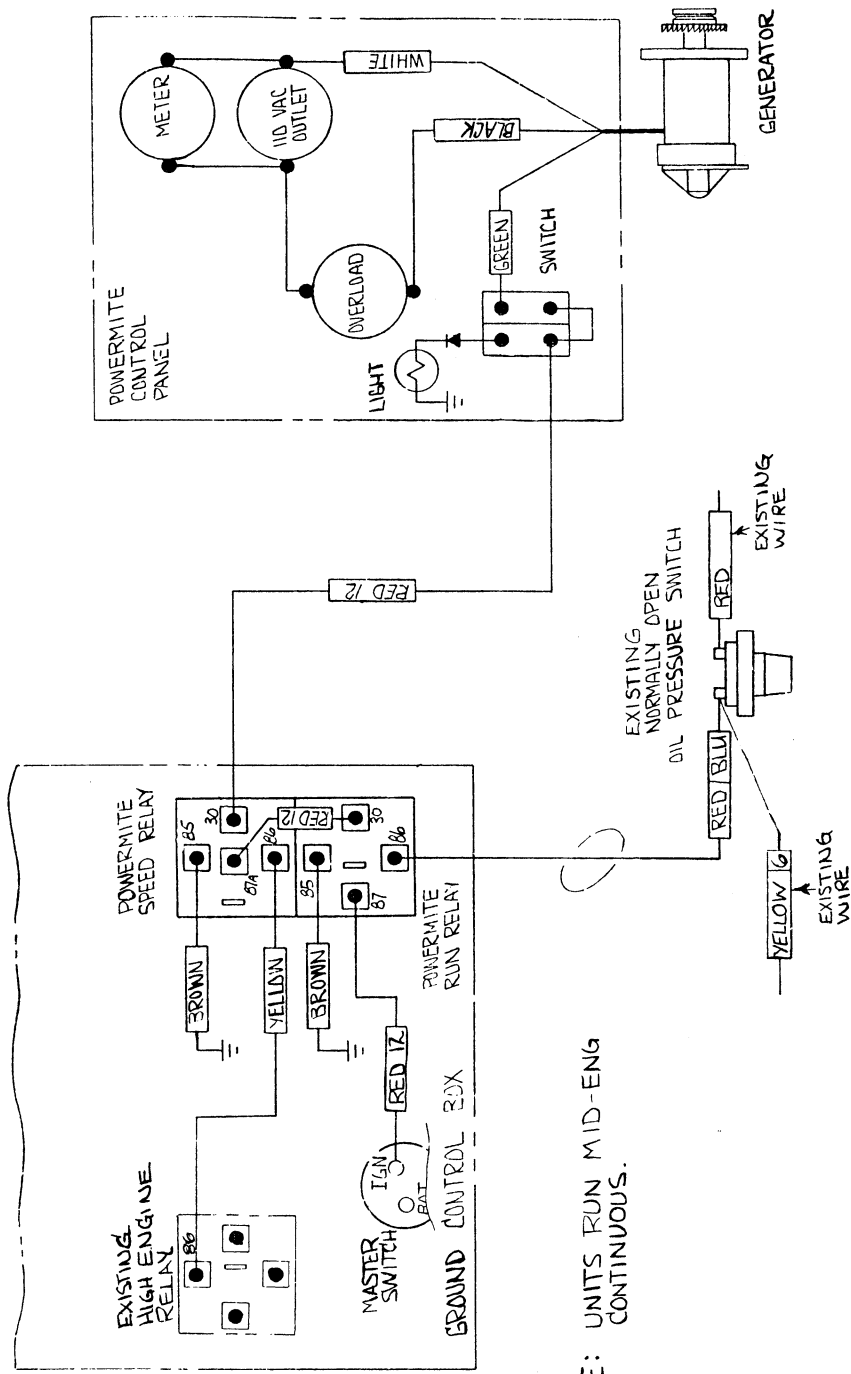

NOTE: UNITS RUN MID-ENG CONTINUOUS.

SEWERS 7 20-10MS

# SECTION 7 ELECTRICAL

FIGURE 7-3. GENERATOR WIRING DIAGRAM - 110VOLT (DEUTZ).

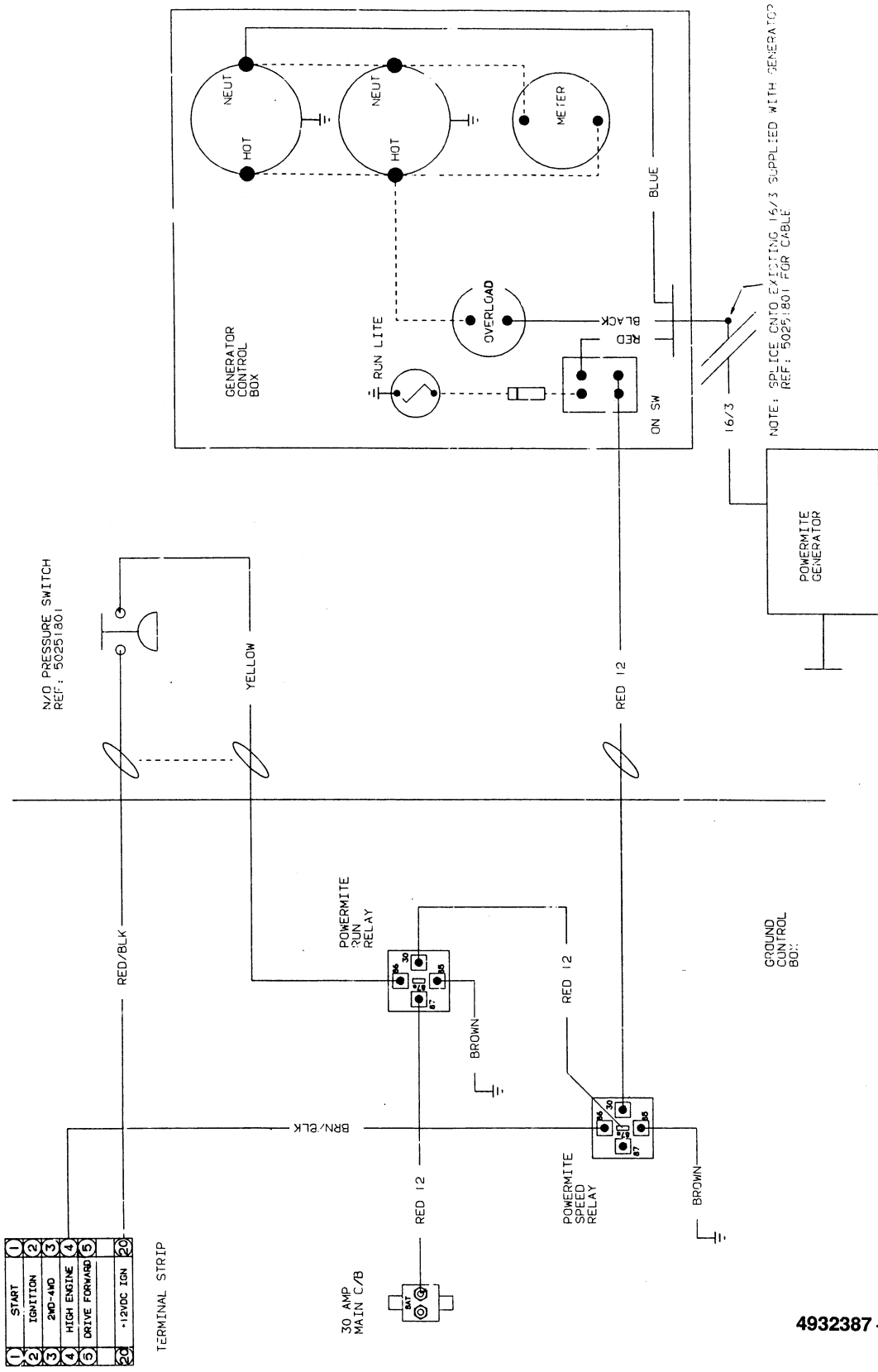

4932387 —

# SECTION 11-7

# ELECTRICAL

FIGURE 7-4. OVERLOAD/TILT INTERLOCK WIRING DIAGRAM (FRENCH SPEC).

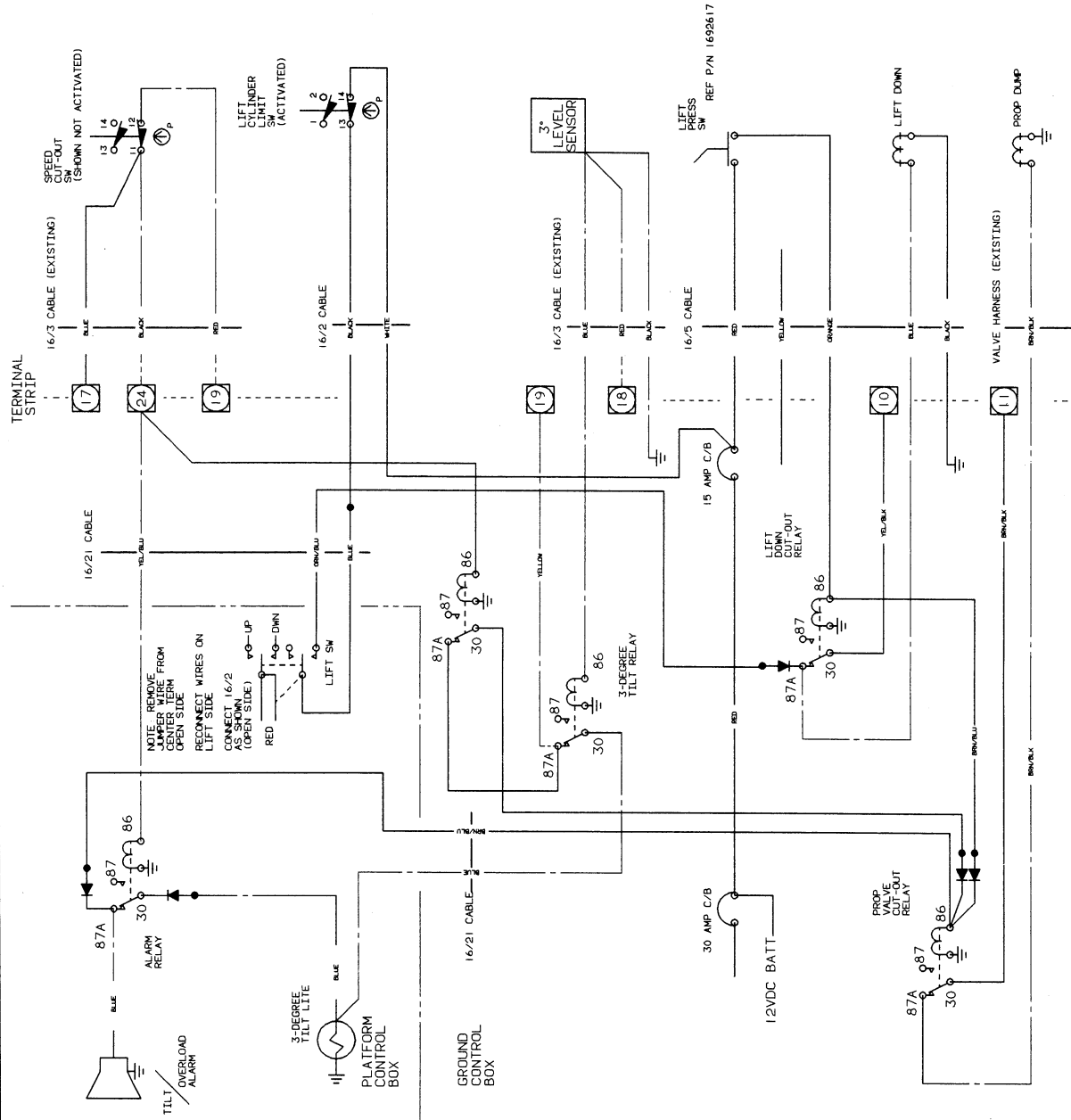

SECTION 11-7 ELECTRICAL

0252366 B

# SECTION 11-7

# ELECTRICAL

FIGURE 7-5. PLATFORM CONTROL BOX WIRING DIAGRAM - DIESEL MACHINES.

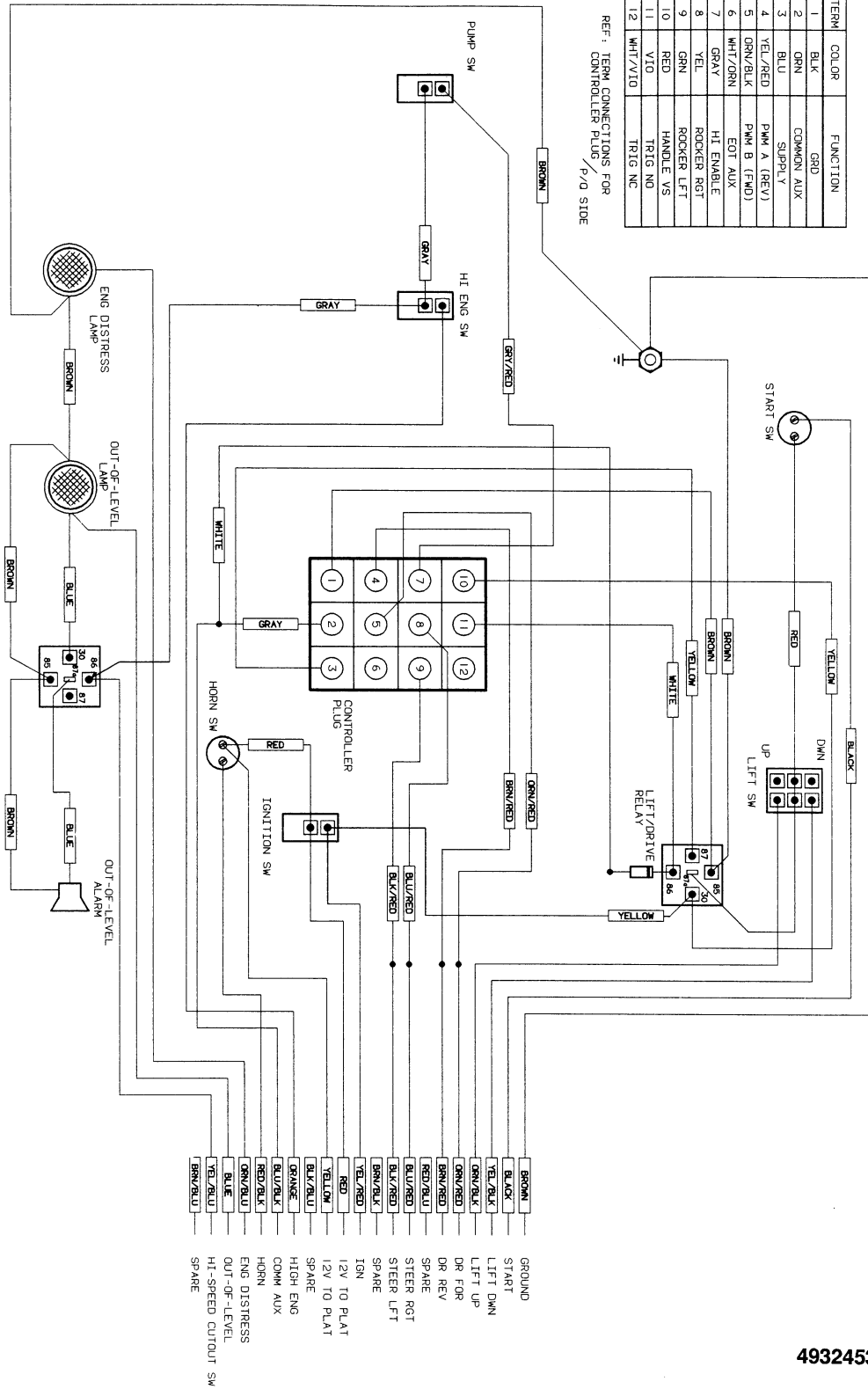

4932453 B

SECTION 11-7 ELECTRICAL

# SECTION 11-7

# ELECTRICAL

FIGURE 7-6. PLATFORM CONTROL BOX WIRING DIAGRAM - GAS MACHINES.

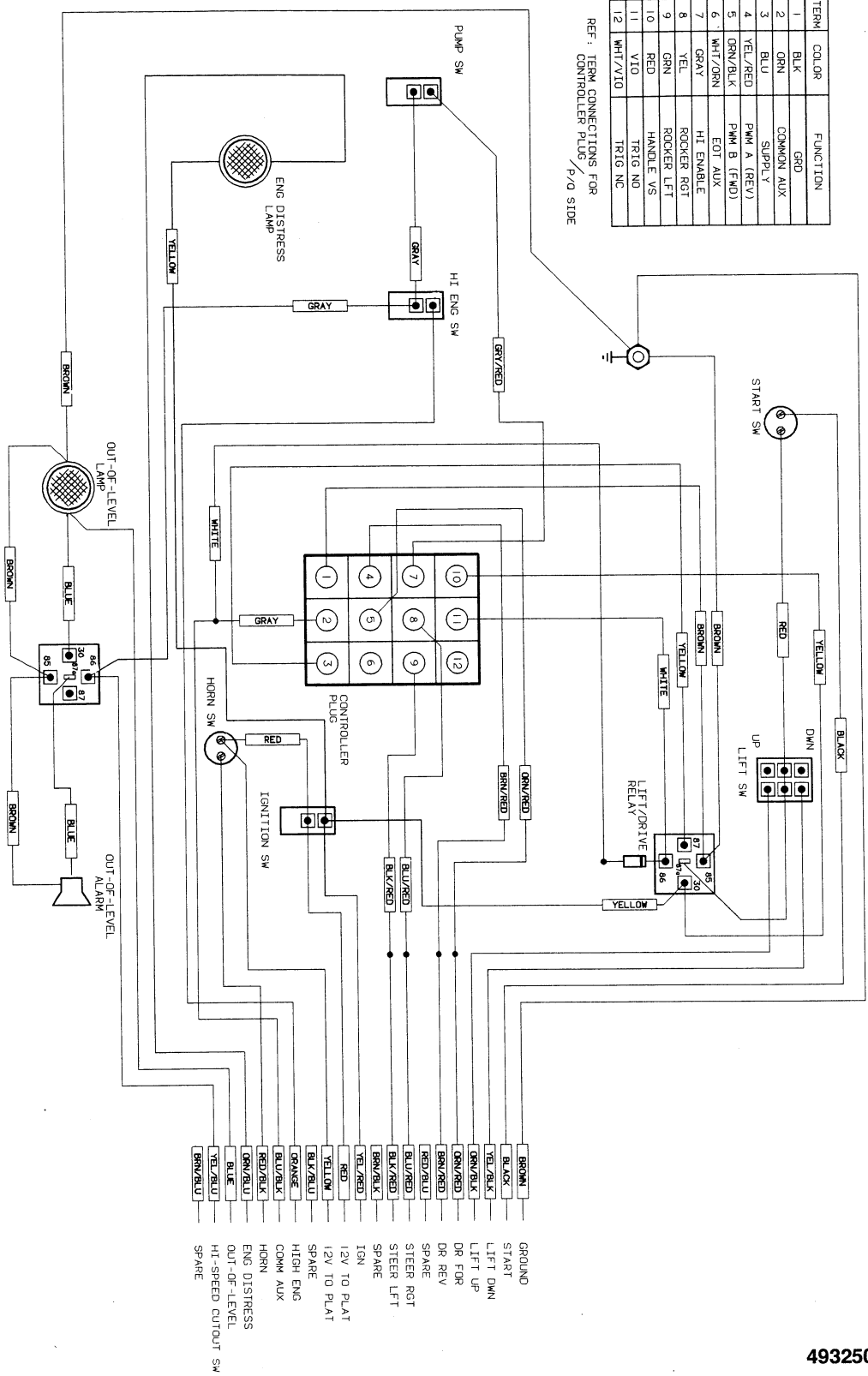

REF: TERM CONNECTIONS FOR CONTROLLER PLUS / P/D SIDE

TERM	COLOR	FUNCTION
1	BLK	GRD
2	ORN	COMMON AUX SUPPLY
3	BLU	PNM A (REV)
4	YEL/RED	PNM B (FWD)
5	DRY/BLK	EOT AUX
6	WHT/ORN	HI ENABLE
7	GRAY	ROCKER RGT
8	YEL	ROCKER LFT
9	GRN	HANDLE VS
10	RED	TRIG NO
11	VIO	TRIG NC
12	WHT/VIO	TRIG NC

# SECTION 11-7 ELECTRICAL

4932506 A

4932506 —



# SECTION 11-7

# ELECTRICAL

FIGURE 7-7. PLATFORM CONTROL BOX WIRING DIAGRAM - ELECTRIC MACHINES.

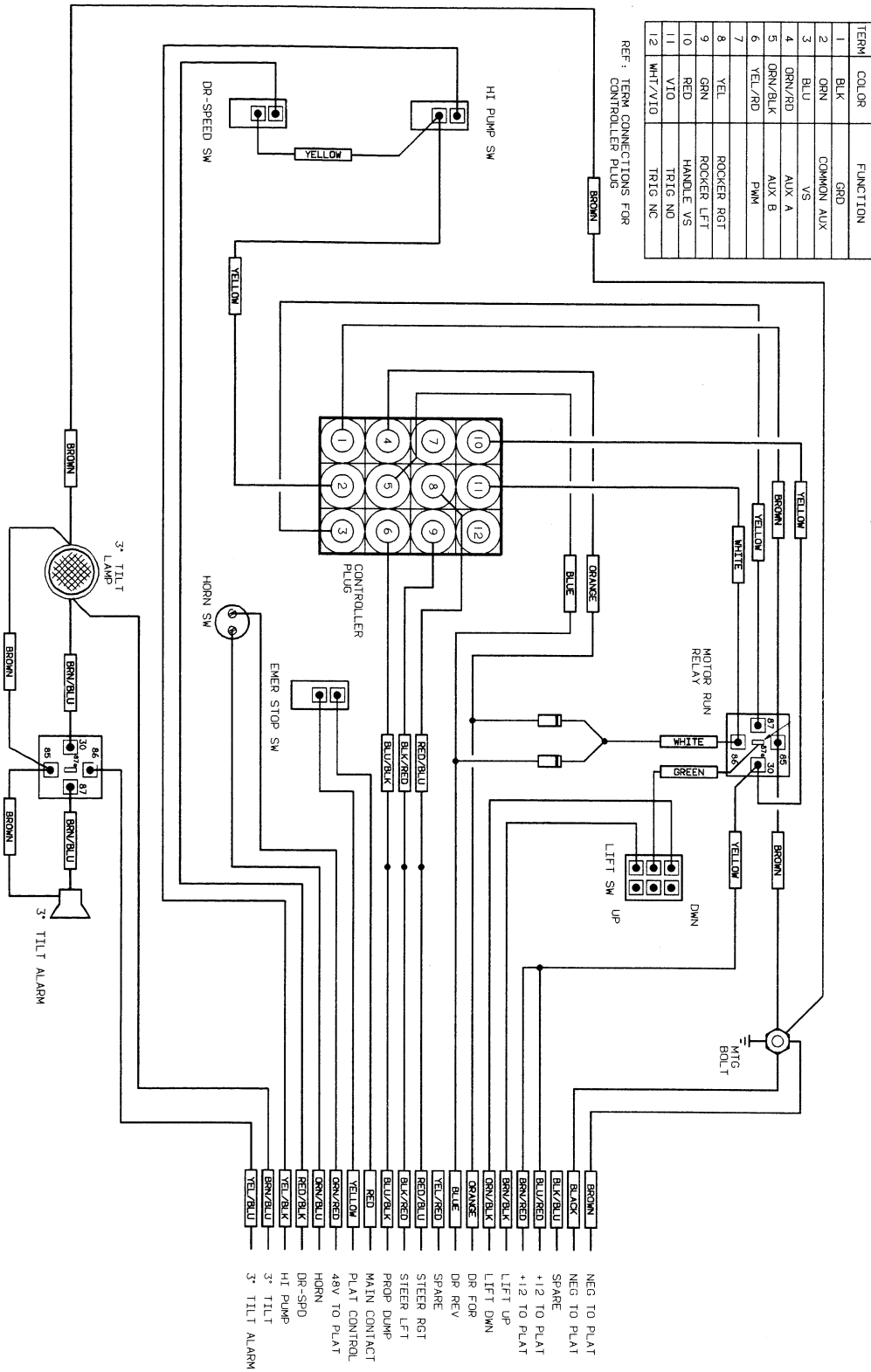
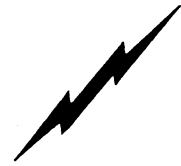

SECTION 11-7 ELECTRICAL

4932409 A







SECTION 11-7

ELECTRICAL

FIGURE 7-10. STANDARD WIRING DIAGRAM - ELECTRIC MACHINES.



SECTION 11-7 ELECTRICAL

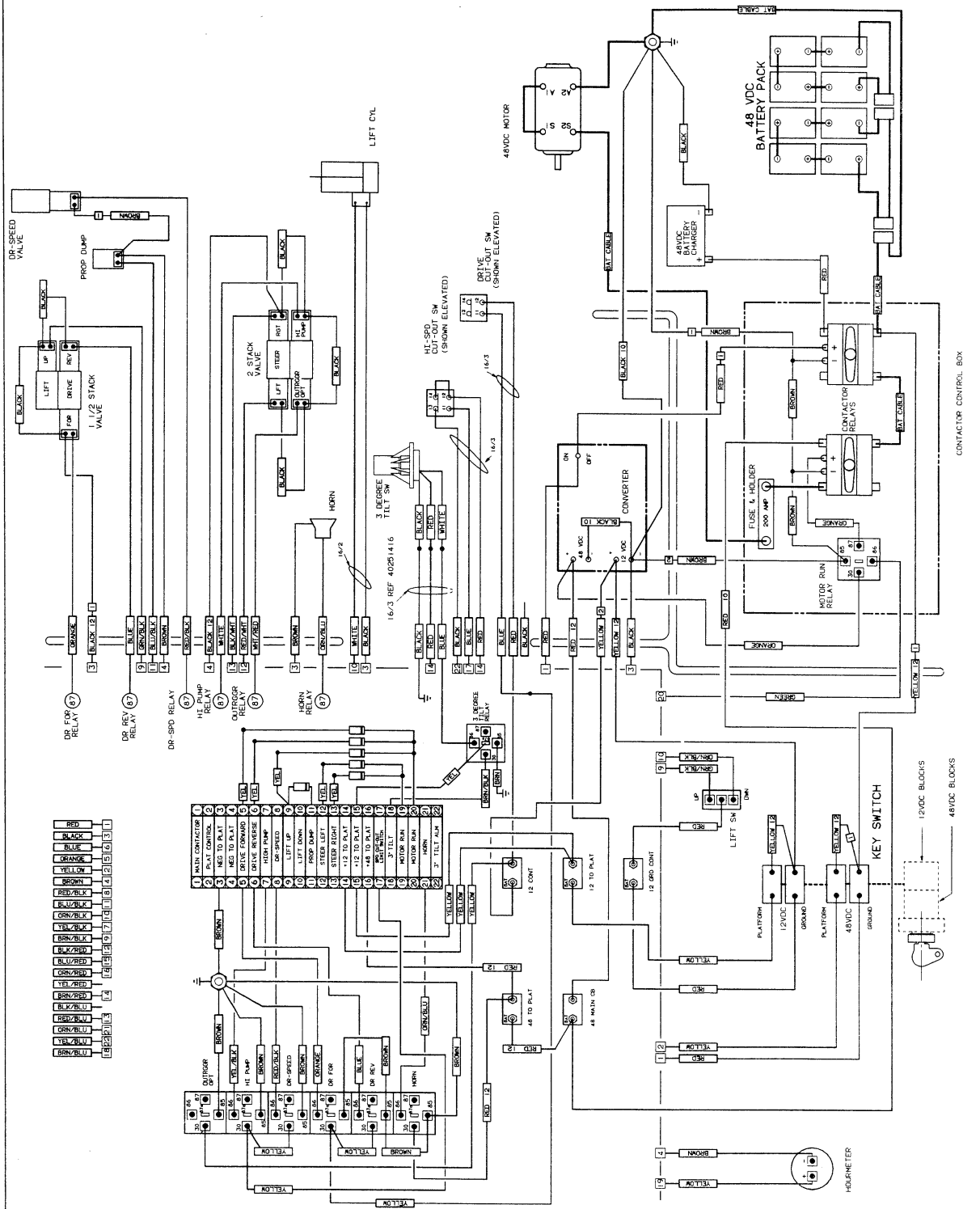

4932408 C

# SECTION 7 ELECTRICAL



FIGURE & ITEM NO	PART NUMBER	DESCRIPTION	QTY.	REV.
7-11		<b>ELECTRICAL COMPONENTS AND WIRING DIAGRAM LIST</b>	Ref.	
		<b>Note: Wiring Diagrams shown are indicated by an asterisk (*). Wiring Diagrams not shown are available from JLG Service Department.</b>		
	1281221	<b>ALARMS WIRING DIAGRAMS - GAS AND DIESEL (DWG ONLY)</b> (Built Prior To April 1992)	Ref.	B
	0250407	<b>ALARM WIRING DIAGRAM - DESCENT (B/M ONLY)</b> (Built Prior to April 1992)	Ref.	B
	3740049	Relay - SPDT	1	
	0140024	Alarm	1	
	0250408	<b>ALARM WIRING DIAGRAM - MOTION (B/M ONLY)</b> (Built Prior to April 1992)	Ref.	C
	3740049	Relay - SPDT	1	
	0140024	Alarm	1	
	3990010	Diode - 6 Amp	4	
	0250406	<b>ALARM WIRING DIAGRAM - TRAVEL (B/M ONLY)</b> (Built Prior to April 1992)	Ref.	C
	3740049	Relay - SPDT	1	
	0140024	Alarm	1	
	3990010	Diode - 6 Amp	2	
	1281810	<b>ALARMS WIRING DIAGRAMS - GAS AND DIESEL (DWG ONLY)</b> (Built April 1992 to Present)	Ref.	—
	0252882	<b>ALARM WIRING DIAGRAM - DESCENT (B/M ONLY)</b> (Built April 1992 to Present)	Ref.	—
	0140024	Alarm	1	
	3740049	Relay - SPDT	1	
	0252883	<b>ALARM WIRING DIAGRAM - MOTION (B/M ONLY)</b> (Built April 1992 to Present)	Ref.	—
	0140024	Alarm	1	
	3990010	Diode - 6 Amp	1	
	3740049	Relay - SPDT	1	
	1281280	<b>ALARMS WIRING DIAGRAMS - ELECTRIC MACHINES (DWG. ONLY)</b> (Built Prior to April 1992)	Ref.	B
	0250718	<b>ALARM WIRING DIAGRAM - DESCENT (B/M ONLY)</b> (Built Prior to April 1992)	Ref.	A
	0140026	Alarm	1	
	0860617	Box, Electrical	1	
	0250719	<b>ALARM WIRING DIAGRAM - MOTION (B/M ONLY)</b> (Built Prior to April 1992)	Ref.	A
	0140026	Alarm	1	
	0860617	Box, Electrical	1	
	3990010	Diode - 6 Amp	4	

SECTION 7 ELECTRICAL

## SECTION 7

## ELECTRICAL



FIGURE & ITEM NO	PART NUMBER	DESCRIPTION	QTY.	REV.
7—11		<b>ELECTRICAL COMPONENTS AND WIRING DIAGRAM LIST (CONTINUED)</b>	Ref.	
	0250717	<b>ALARM WIRING DIAGRAM - TRAVEL (B/M ONLY)</b> (Built Prior to April 1992)	Ref.	A
	0140026	Alarm	1	
	0860617	Box, Electrical	1	
	3990010	Diode - 6 Amp	2	
	1281813	<b>ALARMS WIRING DIAGRAMS - ELECTRIC MACHINES (DWG. ONLY)</b> (Built April 1992 to Present)	Ref.	—
	0252904	<b>ALARM WIRING DIAGRAM - DESCENT (B/M ONLY)</b> (Built April 1992 to Present)	Ref.	—
	0140025	Alarm	1	
	0252905	<b>ALARM WIRING DIAGRAM - MOTION (B/M ONLY)</b> (Built April 1992 to Present)	Ref.	—
	0140025	Alarm	1	
	3990010	Diode - 6 Amp	4	
	0252903	<b>ALARM WIRING DIAGRAM - TRAVEL (B/M ONLY)</b> (Built April 1992 to Present)	Ref.	—
	0140025	Alarm	1	
	3990010	Diode - 6 Amp	2	
	0251754	<b>BATTERY WIRING DIAGRAM - ELECTRIC MACHINES ONLY</b> (See Figure 2-14)	Ref.	A
	0251319	<b>BATTERY CAPACITY INDICATOR GAUGE WIRING DIAGRAM - ELECTRIC MACHINES ONLY (OPTIONAL)</b>	Ref.	—
	2420075	Gauge, Battery Capacity Indicator	1	
	0250809	<b>BEACON LIGHT WIRING DIAGRAM (PLATFORM MOUNTED)</b>	Ref.	—
	2920018	Light, Beacon - Amber	1	
	3740049	Relay - SPDT	1	
	1060016	Cable, Electrical - 16/3	16 ft./4.9m	

SECTION 7 ELECTRICAL

# SECTION 7 ELECTRICAL



FIGURE & ITEM NO	PART NUMBER	DESCRIPTION	QTY.	REV.
7-11		<b>ELECTRICAL COMPONENTS AND WIRING DIAGRAM LIST (CONTINUED)</b>	Ref.	
	0252266	<b>BEACON LIGHT WIRING DIAGRAM (FRAME MOUNTED)</b>	Ref.	—
	2920018	Light, Beacon - Amber	1	
	3740049	Relay - SPDT	1	
	1060016	Cable, Electrical - 16/3	6 ft./1.83m	
	0250762	<b>DETACHABLE PLATFORM CONTROL BOX WIRING DIAGRAM (OPTIONAL)</b>	Ref.	—
	1281738*	<b>DUAL FUEL WIRING DIAGRAM - FORD (DWG ONLY)</b> (See Figure 7-1)	Ref.	G
	4932451	<b>DUAL FUEL WIRING DIAGRAM - FORD (B/M ONLY)</b>	Ref.	—
	4360201	Switch, Toggle - DPDT	1	
	4921305	Harness (Platform Box to Vacuum Switch)	1	
	4932387*	<b>GENERATOR WIRING DIAGRAM - 110 VOLT (DEUTZ)</b> (See Figure 7-3)	Ref.	—
	3990010	Diode - 6 Amp	1	
	3740049	Relay - SPDT	2	
	1060012	Cable, Electrical - 12/4	4 ft./12.2m	
	4360037	Switch, Pressure - Oil	1	
	4932041*	<b>GENERATOR WIRING DIAGRAM - 110 VOLT (FORD)</b> (See Figure 7-2)	Ref.	B
	3990010	Diode - 6 Amp	1	
	3740049	Relay - SPDT	2	
	4932388	<b>HEADLIGHT AND TAILLIGHT WIRING DIAGRAM (OPTIONAL)</b>	Ref.	—
	4360199	Switch, Toggle - SPST	1	
	1281804	<b>LEVELING JACKS WIRING DIAGRAM (DWG ONLY)</b>	Ref.	—
	4931981	<b>LEVELING JACKS WIRING DIAGRAM (B/M ONLY)</b>	Ref.	D
	3740049	Relay - SPDT	1	
	4921205	Harness - Pump	1	
	4921206	Harness - Dump	1	
	3990010	Diode - 6 Amp	1	
	1060018	Cable, Electrical - 16/12 (CM40RT) (CM33RT) (CM25RT)	A/R 70 ft./21.4m 65 ft./19.8m 51 ft./15.61m	
	1060341	<b>LIFT CYLINDER WIRING DIAGRAM</b> Cable, Electric - 16/2	Ref. 24 ft./7.3m	
	0252366*	<b>OVERLOAD/TILT INTERLOCK WIRING DIAGRAM (FRENCH SPEC)</b> (See Figure 7-4)	Ref.	B
	3740069	Relay	2	
	4360232	Breaker, Circuit	1	

SECTION 7 ELECTRICAL

# SECTION 7

# ELECTRICAL



SECTION 7 ELECTRICAL

FIGURE & ITEM NO	PART NUMBER	DESCRIPTION	QTY.	REV.
7-11		<b>ELECTRICAL COMPONENTS AND WIRING DIAGRAM LIST (CONTINUED)</b>	Ref.	
	3990010	Diode - 6 Amp	5	
	1692617	Switch, Pressure	1	
	4460428	Connector, Strain Relief	1	
	1060042	Cable, Electrical - 16/5	24 ft./7.3m	
	4932453*	<b>PLATFORM CONTROL BOX WIRING DIAGRAM - DIESEL MACHINES (See Figure 7-5)</b>	Ref.	B
	4921398	Harness - Controller	1	
	4920830	Harness - Lift	1	
	4932506*	<b>PLATFORM CONTROL BOX WIRING DIAGRAM - GAS MACHINES (See Figure 7-6)</b>	Ref.	—
	4921398	Harness - Controller	1	
	4920830	Harness - Lift	1	
	4932409*	<b>PLATFORM CONTROL BOX WIRING DIAGRAM - ELECTRIC MACHINES (See Figure 7-7)</b>	Ref.	A
	4921267	Harness - Controller	1	
	0251704	<b>PLATFORM EXTENSION LIMIT SWITCH WIRING DIAGRAM (FRENCH AND ITALIAN SPECS)</b>	Ref.	A
	1060039	<b>PLATFORM TO GROUND CABLE WIRING DIAGRAM</b> Cable, Electrical - 16/24 (CM40RT) (CM33RT) (CM25RT)	Ref. A/R 70 ft./21.4m 65 ft./19.8m 51 ft./15.6m	
	1060308	<b>RECEPTACLE WIRING DIAGRAM - 110 VOLT (OPTIONAL)</b> Cable, Electrical - 12/3 (CM40RT) (CM33RT) (CM25RT)	Ref. A/R 70 ft./21.4m 65 ft./19.8m 51 ft./15.6m	
	4932458*	<b>STANDARD WIRING DIAGRAM - FORD GAS MACHINES (See Figure 7-8)</b>	Ref.	B
	3990010	Diode - 6 Amp	5	
	4921402	Harness - Valve	1	
	4921401	Harness - Engine	1	
	1060016	Cable, Electrical - 16/3 (To Cut-Out Switches)	24 FT./7.3M	
	4932459*	<b>STANDARD WIRING DIAGRAM - DEUTZ DIESEL MACHINES (See Figure 7-9)</b>	Ref.	B
	3990010	Diode - 6 Amp	4	
	4921402	Harness - Valve	1	
	4921403	Harness - Engine	1	
	1060016	Cable, Electrical - 16/3 (To Cut-Out Switches)	24 ft./7.3m	
	3730003	Resistor - 20 Ohm	1	

# SECTION 7

# ELECTRICAL



FIGURE & ITEM NO	PART NUMBER	DESCRIPTION	QTY.	REV.
7-11		<b>ELECTRICAL COMPONENTS AND WIRING DIAGRAM LIST (CONTINUED)</b>	Ref.	
	4932408*	<b>STANDARD WIRING DIAGRAM - ELECTRIC MACHINES</b> (See Figure 7-10)	Ref.	C
	3990010	Diode - 6 Amp	6	
	4921377	Harness - Motor	1	
	4921376	Harness - Valve	1	
	1060300	Cable, Electric - 16/3 (To Cut-Out Switches)	25 ft./7.6m	
	1281563	<b>TRAVERSING PLATFORM WIRING DIAGRAM (WITHOUT LEVELING JACKS) (DWG. ONLY)</b>	Ref.	—
	3510336	<b>TRAVERSING PLATFORM WIRING DIAGRAM (B/M ONLY) (CM40RT WITHOUT LEVELING JACKS)</b>	Ref.	B
	3510335	<b>TRAVERSING PLATFORM WIRING DIAGRAM (B/M ONLY) (CM33RT WITHOUT LEVELING JACKS)</b>	Ref.	B
	3510334	<b>TRAVERSING PLATFORM WIRING DIAGRAM (B/M ONLY) (CM25RT WITHOUT LEVELING JACKS)</b>	Ref.	B
	4360202	Switch, Toggle	2	
	3990010	Diode - 6 Amp	2	
	1060016	Cable, Electrical - 16/3 (Cut-Out Switch to Drive Relays) (CM40RT)	A/R 70 ft./21.4m	
		(CM33RT)	65 ft./19.8m	
		(CM25RT)	51 ft./15.6m	
	1060016	Cable, Electrical - 16/3 (Platform Extension Switch to Ground Extension Switch) (CM40RT)	A/R 131 ft./40m	
		(CM33RT)	111 ft./83m	
		(CM25RT)	93 ft./28.35m	
	1281610	<b>TRAVERSING PLATFORM WIRING DIAGRAM (WITH LEVELING JACKS) (DWG ONLY) (OPTIONAL ON MACHINES BUILT PRIOR TO JUNE 1992)</b>	Ref.	—
	3510341	<b>TRAVERSING PLATFORM WIRING DIAGRAM (B/M ONLY) (CM40RT WITH LEVELING JACKS)</b>	Ref.	A
	3510340	<b>TRAVERSING PLATFORM WIRING DIAGRAM (B/M ONLY) (CM33RT WITH LEVELING JACKS)</b>	Ref.	A
	3510339	<b>TRAVERSING PLATFORM WIRING DIAGRAM (B/M ONLY) (CM25RT WITH LEVELING JACKS)</b>	Ref.	A
	4360202	Switch, Toggle	2	
	3990010	Diode - 6 Amp	2	
	1060016	Cable, Electrical - 16/3 (Cut-Out Switch to Drive Relays) (CM40RT)	A/R 61 ft./18.6m	
		(CM33RT)	51 ft./15.6m	
		(CM25RT) (Not Required)	0	
	1060018	Cable, Electrical - 16/12 (Platform Extension Switch to Ground Extension Switch) (CM40RT)	A/R 70 ft./21.4m	
		(CM33RT)	65 ft./19.8m	
		(CM25RT)	51 ft./15.6m	
	0251805	<b>WORKLIGHTS WIRING DIAGRAM - PLATFORM (OPTIONAL)</b>	Ref.	—
	2920013	Worklight	2	

SECTION 7 ELECTRICAL







**TABLE OF CONTENTS**

FIGURE NO.	DESCRIPTION	PAGE NO.
8-1	Decals Installation .....	8-2

**S  
E  
C  
T  
I  
O  
N  
  
8  
  
D  
E  
C  
A  
L  
S**

# SECTION 8

# DECALS



FIGURE 8-1. DECALS INSTALLATION.

NOTE: CM33RT SHOWN. USE THIS ILLUSTRATION AND PARTS LIST TO REFERENCE COMPONENTS FOR CM25RT AND CM40RT ALSO.

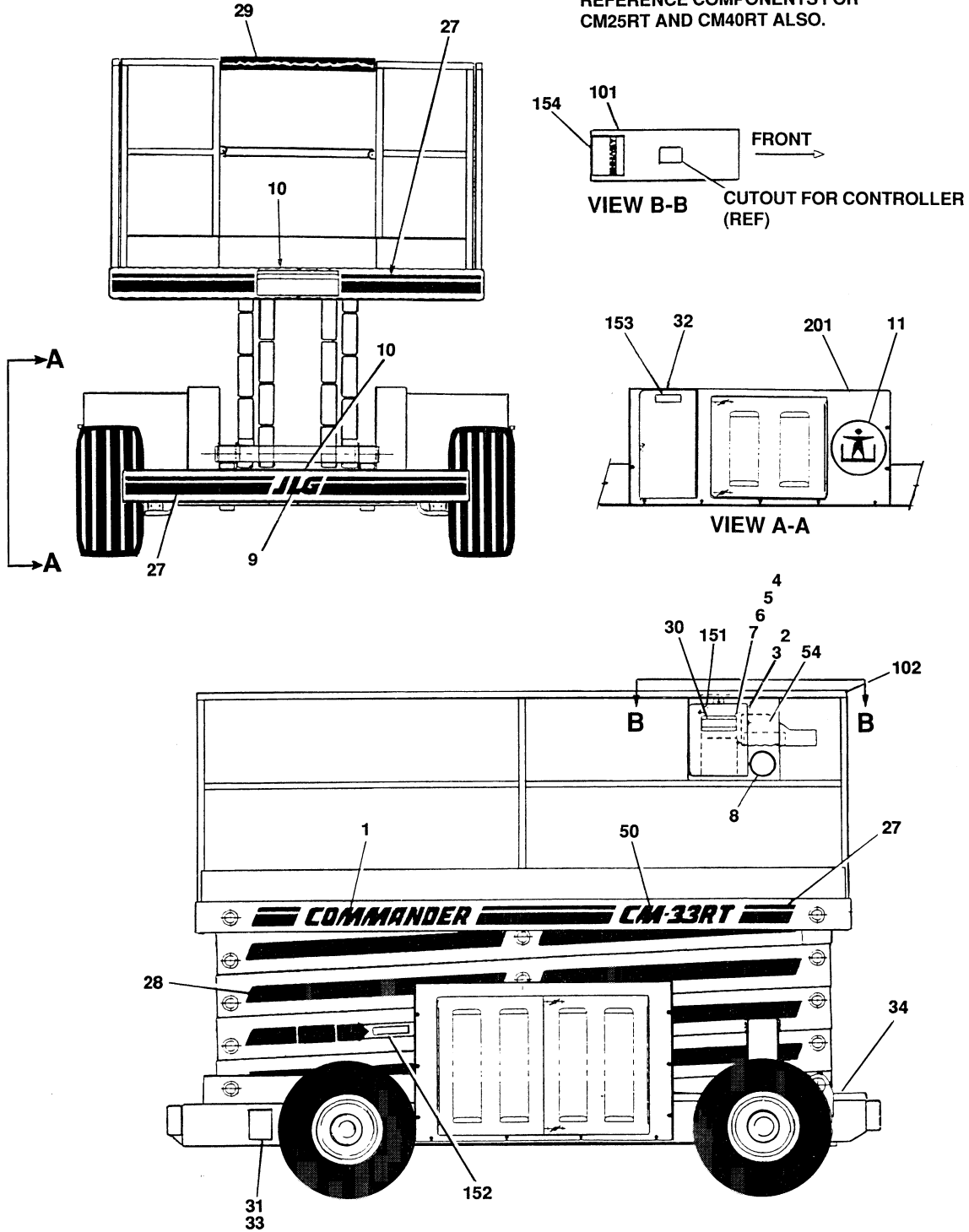

SECTION 8 DECALS

# SECTION 8

# DECALS



FIGURE & ITEM NO	PART NUMBER	DESCRIPTION	QTY.	REV.
8-1		<b>DECALS INSTALLATION</b>	Ref.	
	0251983	<b>DECALS INSTALLATION (COMMON PARTS)</b>	Ref.	—
—1	1701069	Decal - Commander	2	
—2	0860520	Box, Manual Storage	1	
—3	1060279	Cable, Lanyard	1	
—4	0641405	Bolt 1/4"-20NC x 5/8"	4	
—5	3311401	Nut 1/4"-20NC	4	
—6	4751400	Flatwasher 1/4"	4	
—7	4761400	Lockwasher 1/4"	4	
—8	3251813	Decal - U.S.A.	1	
—9	1701110	Decal - JLG	2	
—10	4420039	Tape, Safety Tread	3 ft./.9m	
—11	1700427	Decal - Logo	1	
	0251985	<b>DECALS INSTALLATION - CM40RT WITH HYDRAULIC TRAVERSING PLATFORM (VARIABLE PARTS)</b>	Ref.	D
—111	1701291	Decal - Model CM40RT	2	
—112	1701310	Decal - Strip (Orange)	84 ft./25.6m	
—113	3251992	Nameplate - Capacity	1	
—114	3251992	Nameplate - Capacity	1	
	0251986	<b>DECALS INSTALLATION - CM33RT WITH FIXED OR MANUALLY EXTENDABLE PLATFORM (VARIABLE PARTS)</b>	Ref.	D
—121	1701258	Decal - Model CM33RT	2	
—122	1701310	Decal - Strip (Orange)	67 ft./20.4m	
—123	3252167	Nameplate - Capacity	1	
—124	3252168	Nameplate - Capacity	1	
—125	3252186	Nameplate - Capacity	1	
	0251987	<b>DECALS INSTALLATION - CM33RT WITH HYDRAULIC TRAVERSING PLATFORM (VARIABLE PARTS)</b>	Ref.	D
—131	1701258	Decal - Model CM33RT	2	
—132	1701310	Decal - Strip (Orange)	67 ft./20.4m	
—133	3251993	Nameplate - Capacity	1	
—134	3251993	Nameplate - Capacity	1	
	0251988	<b>DECALS INSTALLATION - CM25RT WITH FIXED AND MANUALLY EXTENDABLE PLATFORM (VARIABLE PARTS)</b>	Ref.	D
—141	1701369	Decal - Model CM25RT	2	
—142	1701310	Decal - Strip (Orange)	51 ft./15.6m	
—143	3252171	Nameplate - Capacity	1	
—144	3252172	Nameplate - Capacity	1	
—145	3252186	Nameplate - Capacity	1	

SECTION 8 DECALS

**SECTION 8**

**DECALS**



FIGURE & ITEM NO	PART NUMBER	DESCRIPTION	QTY.	REV.
8-1		<b>DECALS INSTALLATION (CONTINUED)</b>	Ref.	
	0251989	<b>DECALS INSTALLATION - CM25RT WITH HYDRAULIC TRAVERSING PLATFORM (VARIABLE PARTS)</b>	Ref.	D
-151	1701369	Decal - Model CM25RT	2	
-152	1701310	Decal - Strip (Orange)	51 ft./15.6m	
-153	3252008	Nameplate - Capacity	1	
-154	3252008	Nameplate - Capacity	1	
	1281629	<b>DECALS INSTALLATION (STANDARD PARTS)</b>	Ref.	G
-26	Not Used			
-27	1700431	Decal - Stripe (Brown/Orange)	27.5/6.8m	
-28	1701310	Decal - Stripe (Orange)	A/R	
		CM40RT	84 ft./25.6m	
		CM33RT	67 ft./20.4m	
		CM25RT	51 ft./15.6m	
-29	3340564	Pad	1	
-30	1700157	Decal - Manuals	1	
-31	Consult Factory	Nameplate - Serial Number	1	
-32	1701504	Decal - Hydraulic Fluid	1	
-33	3820001	Rivet 1/8"	20	
-34	1701510	Decal - Manual Descent	1	
	1281629	<b>DECALS INSTALLATION - MODEL DESIGNATION (VARIABLE PARTS)</b>	Ref.	G
-50	1701291	Decal - Model CM40RT	2	
	1701258	Decal - Model CM33RT	2	
	1701369	Decal - Model CM25RT	2	
	1281629	<b>DECALS INSTALLATION - CAPACITY</b>	Ref.	G
-101		Capacity Nameplate Options:		
	3252122	Fixed Platform - CM40RT	1	
	3252121	Fixed Platform - CM33RT	1	
	3252120	Fixed Platform - CM25RT	1	
	3252119	Manually Extendable Platform - CM40RT	1	
	3252118	Manually Extendable Platform - CM33RT	1	
	3252117	Manually Extendable Platform - CM25RT	1	
	3252125	Hydraulic Extendable (Traversing) Platform - CM40RT	1	
	3252124	Hydraulic Extendable (Traversing) Platform - CM33RT	1	
	3252123	Hydraulic Extendable (Traversing) Platform - CM25RT	1	
-102	3252129	Nameplate - Capacity (Manually Extendable Platform Only)	1	
	1281629	<b>DECAL INSTALLATION - EURO ENGLISH SPEC</b>	Ref.	G
-151	1701523	Nameplate - Caution	1	

**SECTION 8 DECALS**

## SECTION 8

## DECALS



FIGURE & ITEM NO	PART NUMBER	DESCRIPTION	QTY.	REV.
8-1		<b>DECALS INSTALLATION (CONTINUED)</b>	Ref.	
—152	1700713	Decal - Safety Prop	2	
—153	1701122	Decal - Ground/Emergency Controls	1	
—154	1701257	Decal - Warning	1	
	1281629	<b>DECALS INSTALLATION - FRENCH SPEC</b>	Ref.	G
—151	1701511	Nameplate - Attention	1	
—152	1701512	Decal - Support De Sécurité	2	
—153	1701515	Decal - Commandes Sol	1	
—154	1701546	Decal - Attention	1	
	1281629	<b>DECALS INSTALLATION - GERMAN SPEC</b>	Ref.	G
—151	1701516	Nameplate - Actung	1	
—152	1701519	Decal - Sicherheitsstuetze	2	
—153	1701525	Decal - Boden/Notfall Kontrolle	1	
—154	1701541	Decal - Warning	1	
	1281629	<b>DECALS INSTALLATION - DUTCH SPEC</b>	Ref.	G
—151	1701617	Nameplate - Dagelykse Controle Lyst	1	
—152	1701615	Decal - Veiligheidsbalk	2	
—153	1701616	Decal - Grondbediening	1	
—154	1701647	Decal - Waarschuwing	1	
	1281629	<b>DECALS INSTALLATION - ITALIAN SPEC</b>	Ref.	G
—151	1701520	Nameplate - Attenzione	1	
—152	1701524	Decal - Appoggio Di Sicurezza	2	
—153	1701535	Decal - Comando A Terra	1	
—154	1701547	Decal - Attenzione		
	1281629	<b>DECAL INSTALLATION - SPANISH SPEC</b>	Ref.	G
—151	1701860	Nameplate - Precaucion	1	
—152	1701856	Decal - Puntal De Seguridad	2	
—153	1701858	Decal - Controles Terra/Emerg	1	
—154	1701859	Decal - Precaucion	1	
		<b>DECAL INSTALLATION - FUEL</b>	Ref.	
—201	1700430	Decal - Fuel (Gas)	1	
	1700428	Decal - Fuel (Diesel)	1	
	0251642	<b>CORNER WARNING STRIPES INSTALLATION (EXTENDABLE DECK MACHINES) (NOT SHOWN)</b>	Ref.	—
	4420052	Tape - Yellow/Black	4 ft/1.2m	

SECTION 8 DECALS



# SECTION 9 RECOMMENDED SERVICE PARTS STOCK

CM40RT/CM33RT/CM25RT TRANSMISSION PUMP DRIVE GAS AND DIESEL MACHINES

The following one year list will service each machine with the most commonly used parts. For further information, contact the nearest JLG Parts Department at (717) 485-5104.

PART NO.	DESCRIPTION	QTY.
<b>STANDARD PARTS</b>		
0961409	Bushing, Super Oilite (Figure 1-1)	4
0961029	Bushing, Bronze (Figure 1-1)	4
2900714	Seal Kit - Drive Motor (Figure 1-3)	2
2900766	Seal Kit - Drive Brake (Figure 1-5)	2
2900767	Lining Kit - Drive Brake (Figure 1-5)	2
2900768	Bearing Kit - Drive Brake (Figure 1-5)	2
7010429	Bearing Kit - Drive Hub (Figure 1-6)	2
4360300	Switch, Limit (Figure 1-8 and 4-3))	1
2120110	Element, Hydraulic (Figure 2-1)	4
1340021	Breather (Figure 2-1)	1
4360280	Sensor, Level (Figure 2-1)	1
7000417	Coil - Racine Bang-Bang Dump Section (Figure 2-2)	1
7000418	Coil - Racine Bang-Bang Working Section (Figure 2-2)	2
7000414	Seal Kit - Racine Bang-Bang Working Section (Figure 2-2)	1
7000413	Seal Kit - Racine Bang-Bang Dump Section (Figure 2-2)	1
2900660	Shaft Seal Kit - 3600188 Pump (Figure 2-7 and 2-10)	1
2120136	Element, Filter - 2120135 Charge Filter (Figure 2-7 and 2-10)	4
7003655	Element, Air Filter (Figure 2-7 and 2-10)	1
7007496	Coil Assembly - 3600164 Pump (Figure 2-12)	1
2900752	Seal Kit - Complete - 3600164 Pump (Figure 2-12)	1
2900826	Charge Pump Kit - 3600164 Pump (Figure 2-12)	1
2900827	Cylinder Block Kit - 3600164 Pump (Figure 2-12)	1
4360284	Switch, Key (Select) (Figure 2-15)	1
4360267	Block, Contact (Figure 2-15)	1
4360281	Block, Contact (Figure 2-15)	1
4360198	Switch, Toggle (Lift) (Figure 2-15)	1
3740049	Relay (Figure 2-15, 4-4 and 7-9)	9
4360216	Breaker, Circuit - 30 Amp (Figure 2-15)	1
4360232	Breaker, Circuit - 15 Amp (Figure 2-15 and 7-11)	1
4360274	Switch, Push Button (Start and Horn) (Figure 2-15 and 4-4)	2
4360199	Switch, Toggle (Engine Speed, Pump Speed and Emergency Stop) (Figure 2-15 and 4-4)	2
3340579	Pad, Sliding (Figure 3-1, 3-2 and 3-3)	4
0961409	Bushing, Super Oilite (Figure 4-1 and 4-3)	4
4360260	Switch, Toggle (Lift) (Figure 4-4)	1
1600148	Controller (Drive) (Figure 4-4)	1
4360289	Switch, Push-Pull (Figure 4-4)	1
0961379	Bushing, Bronze - Lift Cylinder Barrel (Figure 5-3)	2
0961380	Bushing, Bronze - Lift Cylinder Rod (Figure 5-3)	2
4640382	Cartridge, Holding Valve (Figures 5-3, 6-4 and 6-5))	1
2901119	Seal Kit - Steer Cylinder (Figure 5-4)	1
4640699	Cartridge, Pull (Manual Descent) (Figure 5-3 and 6-1)	1
3990010	Diode - 6 Amp	6

SECTION 9 RECOMMENDED SERVICE PARTS STOCK

**SECTION 9 RECOMMENDED SERVICE PARTS STOCK**

CM40RT/CM33RT/CM25RT TRANSMISSION PUMP DRIVE GAS AND DIESEL MACHINES

The following one year list will service each machine with the most commonly used parts.  
For further information, contact the nearest JLG Parts Department at (717) 485-5104.

PART NO.	DESCRIPTION	QTY.
<b>VARIABLE PARTS</b>		
0440174	Cup, Bearing (2WD Only) (Figure 1-1)	2
0440175	Cone, Bearing (2WD Only) (Figure 1-1)	2
3960353	Seal, Oil (2WD Only) (Figure 1-1)	2
0960839	Bushing, Bronze (2WD Only) (Figure 1-1)	4
0961029	Bushing, Oilite (4WD Only) (Figure 1-1)	4
2900754	Hub Seal Kit (4WS Front Only) (Figure 1-8)	2
4360277	Limit Switch (French and Italian Spec) (Figure 1-8, 4-2 and 4-3)	1
7004368	Coil - 4640123 Valve (Hydraforce Version) (Figure 2-1)	1
7000558	Coil - 4640123 Valve (FPS Version) (Figure 2-1)	1
7000549	Seal Kit - FPS Valve (Traversing Platform and/or Leveling Jacks Options) (Figure 2-6)	2
7006053	Valve, Relief Cartridge - FPS Valve (Traversing Platform and/or Leveling Jacks Options) (Figure 2-6)	1
4640049	Coil - FPS Valve (Traversing Platform and/or Leveling Jacks Options) (Figure 2-6)	2
1600117	Controller, Governor (Ford Engine) (Figure 2-7)	1
2500005	Governor, Precision (Ford Engine) (Figure 2-7)	1
3740080	Relay, Bosch (Ford Engine) (Figure 2-7)	1
7000878	Rebuild Kit - Carburetor (Ford Engine) (Figure 2-7)	1
7014680	Components Kit (Ford Engine) (Figure 2-7)	1
7014681	Components Kit (Ford Engine) (Figure 2-7)	1
7014682	Tune Up Kit (Ford Engine) (Figure 2-7)	1
0060023	Actuator, Throttle (Deutz Engine) (Figure 2-10)	1
7014683	Tune Up Kit (Deutz Engine) (Figure 2-10)	1
4360201	Switch, Toggle (Select) (Dual Fuel) (Figure 2-15)	1
4360202	Switch, Toggle (Traversing Platform/Leveling Jacks) (Figure 2-15 and 4-4)	1
0961664	Bushing, Composite (CM40RT) (Figure 3-3)	26
0961409	Bushing, Super Oilite (CM33RT and CM25RT) (Figure 3-3)	40
3340587	Pad, Wear (Extendable Platform) (Figure 4-2)	4
0440085	Bearing (Extendable Platform) (Figure 4-2)	4
3340590	Pad, Wear (Traversing Platform) (Figure 4-2)	16
2900379	Seal Kit - Axle Lockout Cylinder (Oscillating Axle) (Figure 5-1)	1
4640525	Cartridge - Axle Lockout Cylinder (Oscillating Axle) (Figure 5-1)	1
2901208	Seal Kit - Leveling Jack Cylinder (Leveling Jacks) (Figure 5-2)	1
2901116	Seal Kit - Lift Cylinder (CM40RT) (Figure 5-3)	1
2901115	Seal Kit - Lift Cylinder (CM33RT and CM25RT) (Figure 5-3)	1
2901121	Seal Kit - Extension Cylinder (Traversing Platform) (Figure 5-5)	1
3740069	Relay (French Spec) (Figure 7-11)	2







Corporate Office  
JLG Industries, Inc.  
1 JLG Drive  
McConnellsburg PA. 17233-9533  
USA  
Phone: (717) 485-5161  
Fax: (717) 485-6417

## JLG Worldwide Locations

---

JLG Industries (Australia)  
P.O. Box 5119  
11 Bolwarra Road  
Port Macquarie  
N.S.W. 2444  
Australia  
Phone: (61) 2 65 811111  
Fax: (61) 2 65 810122

JLG Industries (UK)  
Unit 12, Southside  
Bredbury Park Industrial Estate  
Bredbury  
Stockport  
SK6 2sP  
England  
Phone: (44) 870 200 7700  
Fax: (44) 870 200 7711

JLG Deutschland GmbH  
Max Planck Strasse 21  
D-27721 Ritterhude/Ihlpohl  
Bei Bremen  
Germany  
Phone: (49) 421 693 500  
Fax: (49) 421 693 5035

JLG Industries (Italia)  
Via Po. 22  
20010 Pregnana Milanese - MI  
Italy  
Phone: (39) 02 9359 5210  
Fax: (39) 02 9359 5845

JLG Latino Americana Ltda.  
Rua Eng. Carlos Stevenson,  
80-Suite 71  
13092-310 Campinas-SP  
Brazil  
Phone: (55) 19 3295 0407  
Fax: (55) 19 3295 1025

JLG Europe B.V.  
Jupiterstraat 234  
2132 HJ Foofddorp  
The Netherlands  
Phone: (31) 23 565 5665  
Fax: (31) 23 557 2493

JLG Industries (Norge AS)  
Sofeimyrveien 12  
N-1412 Sofienyr  
Norway  
Phone: (47) 6682 2000  
Fax: (47) 6682 2001

JLG Polska  
Ul. Krolewska  
00-060 Warszawa  
Poland  
Phone: (48) 91 4320 245  
Fax: (48) 91 4358 200

JLG Industries (Europe)  
Kilmartin Place,  
Tannochside Park  
Uddingston G71 5PH  
Scotland  
Phone: (44) 1 698 811005  
Fax: (44) 1 698 811055

JLG Industries (Pty) Ltd.  
Unit 1, 24 Industrial Complex  
Herman Street  
Meadowdale  
Germiston  
South Africa  
Phone: (27) 11 453 1334  
Fax: (27) 11 453 1342

Plataformas Elevadoras  
JLG Iberica, S.L.  
Trapadella, 2  
P.I. Castellbisbal Sur  
08755Castellbisbal  
Spain  
Phone: (34) 93 77 24700  
Fax: (34) 93 77 11762

JLG Industries (Sweden)  
Enkopingsvagen 150  
Box 704  
SE - 175 27 Jarfalla  
Sweden  
Phone: (46) 8 506 59500  
Fax: (46) 8 506 59534

---