



---

# Illustrated Parts Manual

**Models**  
**Ecolift50**  
**Ecolift70**  
**830P**

**P/N**  
**3121743**

May 31, 2018 - Rev D

**ANSI**



---

An Oshkosh Corporation Company



## **REVISION LOG**

April 20, 2016 - A - Original Issue of Manual

November 22, 2016 - B - Revised Manual (Edited to B/M 1001214402 Revision G)

February 10, 2017 - C - Revised Manual (Edited to B/M 1001214402 Revision J)

May 31, 2018 - D - Revised Manual (Edited to B/M 1001214402 Revision J)

# GENERAL INFORMATION

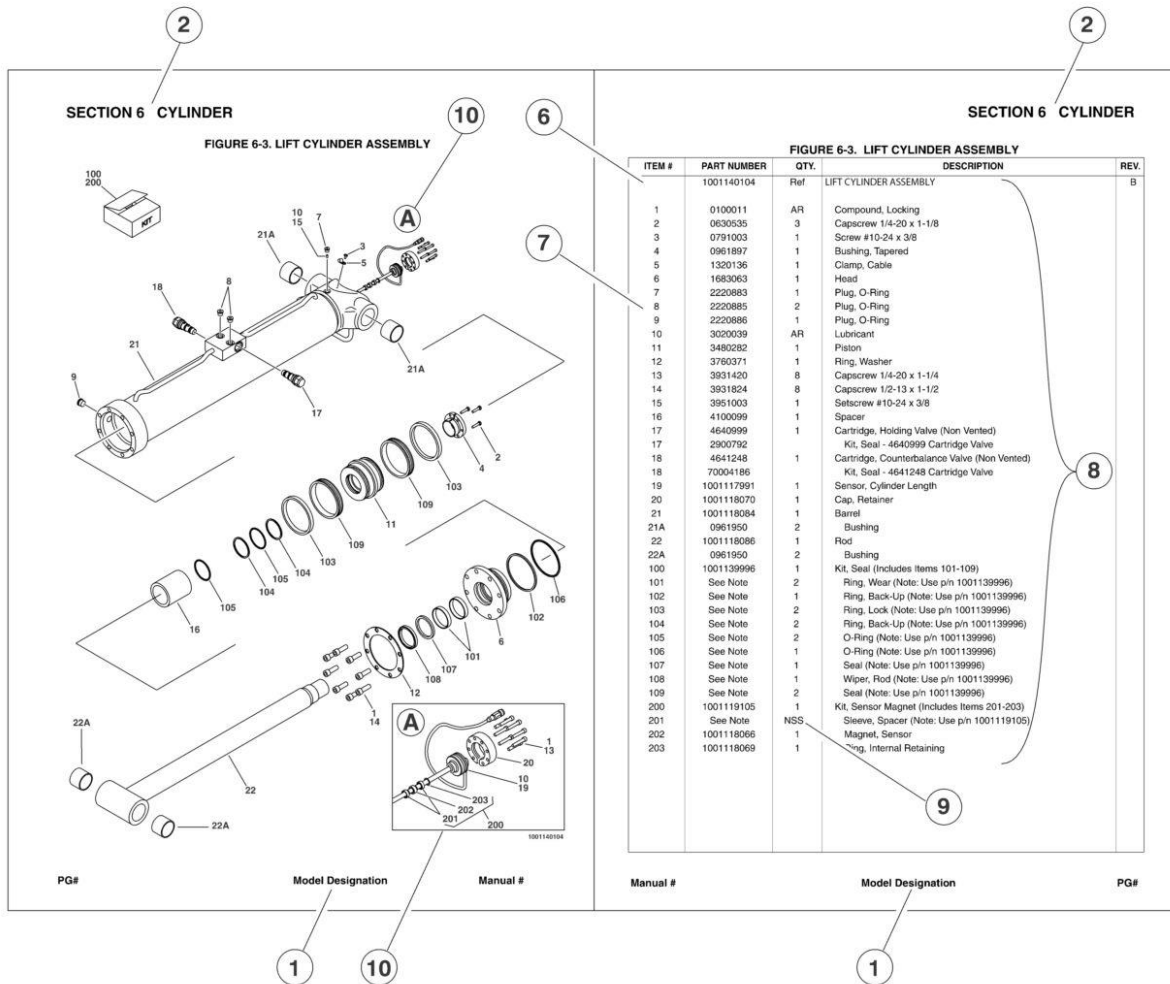

## 1) MACHINE IDENTIFICATION

Machines are identified by model and in some cases a combination of models, serial number (SN) or regional standard (i.e. ANSI, CE, CSA). Components may also be identified by SN or manufacturer. Common components that may be identified by these characteristics are engines and hydraulic components.

## 2) PARTS MANUAL ORGANIZATION

Product information in this manual is organized under section titles. Frame, Cylinder, Hydraulic and Electrical are a few examples. Each section is organized by figure and page number. The information within the Figure is then organized by item number, part number, description and corresponding illustration(s).

## 3) TABLE OF CONTENTS

A table of contents is found toward the beginning of the manual. Figure number, description and page number are provided for quick reference to the page containing the related information.

## 4) RECOMMENDED SPARE PARTS

The Recommended Spare Parts, located near the end of the manual, reference most frequently used maintenance parts.

## 5) PART NUMBER INDEX

A numerical index listing all part numbers and the corresponding page number(s) appears at the back of the manual.

## GENERAL INFORMATION

### 6) NON-SERVICED PARTS

In some instances, it is necessary to display non-serviced parts, assemblies or installations. In the case of assemblies and installations there will be a Ref in the Qty column. In case of parts that are not available for service within assemblies or components, there will be a NSS (Not Sold Separately) or NLA (No Longer Available) listed in the Qty. column of the manual.

### 7) PARTS LIST ITEM NUMBERS

Numbers shown in the item# column correspond to numbers used in the associated illustration (s). Item numbers which are missing from the sequence in the parts list are not used on that page

### 8) INDENTED PARTS DESCRIPTION

An indented part description is included in the item under which it is indented.

### 9) ABB REVIATION AND SYMBOLS

AC.....	.. Alternating Current	LCD.....	.. Liquid Crystal Display
ADE.....	..Advanced Design Electronics	LED.....	.. Light Emitting Diodes
ANSI.....	..American National Standards Institute	LH.....	.. Left Hand
AR.....	..As Required	LSS.....	..Load Sensing System
ASSY.....	.. Assembly	M(m).....	.. Metric/Meter
AUX.....	..Auxiliary	MM (mm).....	..Milimeter
AWG.....	..American WireGauge	mA.....	.. Miliamps
B/M.....	.. Bill of Material	NLA.....	..No Longer Available
CE.....	..European Conformity	NPT.....	.. National Pipe Threads
CCW.....	..Counter Clockwise	NSS.....	..Not So Id Separately
cm.....	..Centimeter	OD.....	..Outside Diameter
CW.....	..Clockwise	ORB.....	.. O-Ring Boss
CSA.....	..Canadian Standards Association	ORFS.....	.. O-Ring Face Seal
CYL.....	..Cylinder	OZ (oz).....	..Ounces
DIA.....	..Diameter	PG.....	..Page
DC.....	..Direct Current	P/N.....	..Part Number
EMS.....	.. Emergency Stop	qt.....	..Quarts
ENG.....	..Engine	QTY.....	..Quantity
FT (ft).....	..Feet	REF.....	..Reference
GA (Ga).....	..Gauge	REV.....	..Revision Level
HYD.....	..Hydraulic	RH.....	.. Right Hand
Hz.....	..Hertz	SAE.....	.. Society of Automotive Engineers
ID.....	..Inside Diameter	SN.....	..Serial Number
in.....	..inches	SPEC(S).....	..Specifications
ISO.....	..International Organization for Standards	T/T.....	..Turntable
JIC.....	..Joint Industry Council	UGM.....	..Universal Ground Module
KG.....	..Kilogram	V.....	..Volts
L.....	..Liter	W.....	..Watts
LB.....	..Pounds	#.....	.. Number

### 10) ILLUSTRATION REFERENCE LETTERS

When necessary, illustrations may contain reference letters that are intended to track information (i. e. hoses, harnesses) from one point to another or to track visual enlargement of components to show details that may be located in another area on the illustration.

*Note: Due to continuous product improvements, JLG Industries, Inc. reserves the right to make specification changes without prior notification. Contact JLG Industries, Inc. for updated information.*



# TABLE OF CONTENTS

SECTION 1 - ECOLIFT50 .....	9
FIGURE 1-1. COMPONENTS .....	10
FIGURE 1-2. DECAL INSTALLATION (ANSI) .....	14
FIGURE 1-3. DECAL INSTALLATION (CSA/FRE) .....	16
FIGURE 1-4. DECAL INSTALLATION (PORTUGUESE) .....	18
FIGURE 1-5. DECAL INSTALLATION (SPANISH) .....	20
FIGURE 1-6. RECOMMENDED SERVICE PARTS STOCK .....	22
FIGURE 1-7. SPECIAL OPTIONS .....	24
SECTION 2 - ECOLIFT70 .....	25
FIGURE 2-1. COMPONENTS .....	26
FIGURE 2-2. DECAL INSTALLATION (ANSI) .....	30
FIGURE 2-3. DECAL INSTALLATION (CSA/FRE) .....	32
FIGURE 2-4. DECAL INSTALLATION (PORTUGUESE) .....	34
FIGURE 2-5. DECAL INSTALLATION (SPANISH) .....	36
FIGURE 2-6. RECOMMENDED SERVICE PARTS STOCK .....	38
FIGURE 2-7. SPECIAL OPTIONS .....	40
SECTION 3 - 830P .....	41
FIGURE 3-1. CHASSIS AND MAST COMPONENTS .....	42
FIGURE 3-2. PLATFORM COMPONENTS .....	46
FIGURE 3-3. ELECTRICAL AND HYDRAULIC COMPONENTS .....	48
FIGURE 3-4. DECAL INSTALLATION (ANSI) .....	50
FIGURE 3-5. DECAL INSTALLATION (CSA/FRE) .....	52
FIGURE 3-6. DECAL INSTALLATION (PORTUGUESE) .....	54
FIGURE 3-7. DECAL INSTALLATION (SPANISH) .....	56
FIGURE 3-8. RECOMMENDED SERVICE PARTS STOCK .....	58
FIGURE 3-9. SPECIAL OPTIONS .....	60
PART NUMBER INDEX .....	61





**SECTION 1 - ECOLIFT50**

# SECTION 1 - ECOLIFT50

## FIGURE 1-1. COMPONENTS

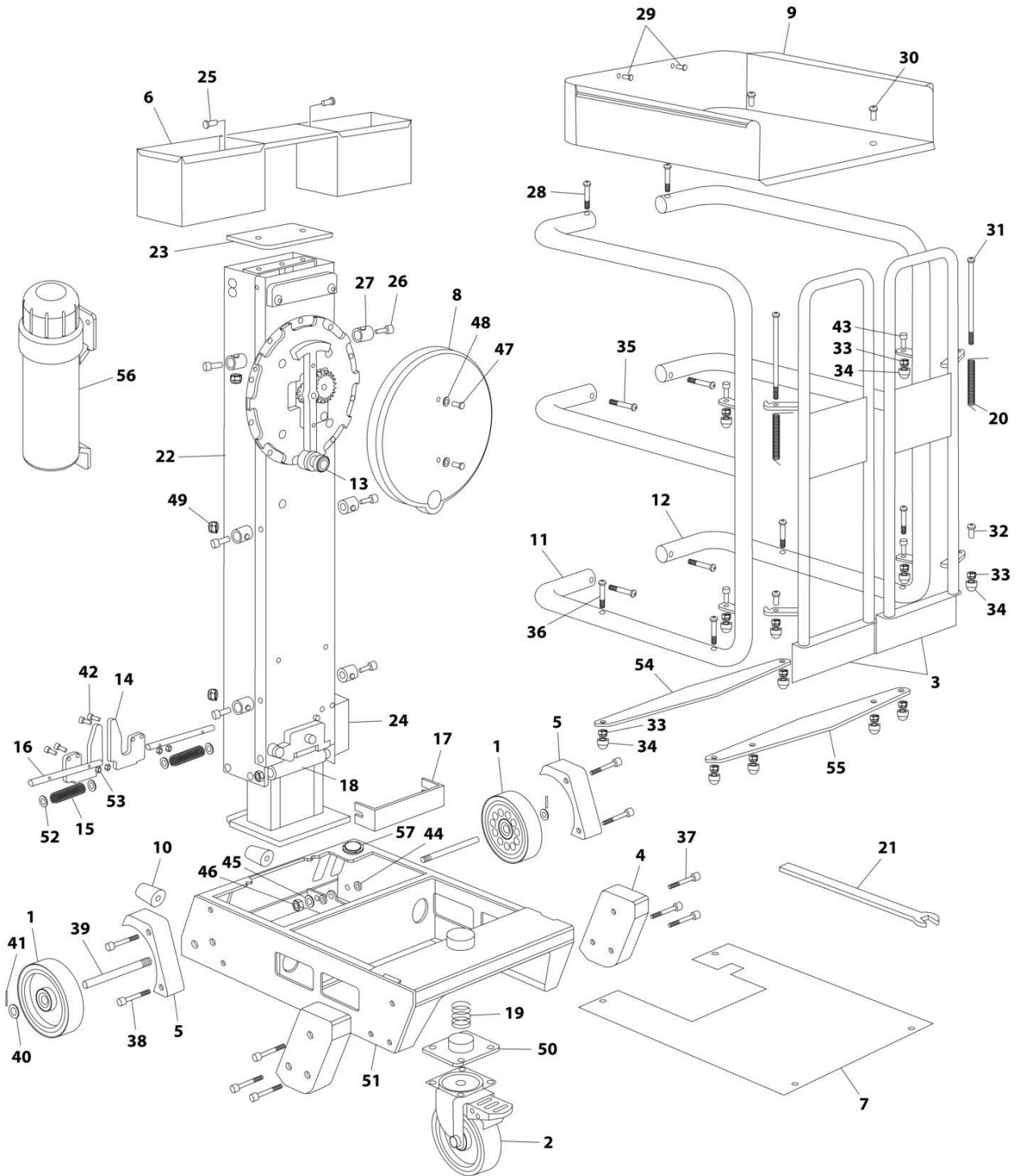

ART\_Ecolift50\_1

FIGURE 1-1. COMPONENTS

ITEM	PART NUMBER	QTY	DESCRIPTION	REV
1	PELM400	2	Wheel/Brake Sprocket	
2	PELM401	1	Swivel Castor	
3	PELM402JO	2	Gates (pair)	
4	PELM403	2	Corner Foot	
5	PELM404	2	Mudguard	
6	PELM405	1	Tool Box	
7	PELM406	1	Chassis Cover	
8	PELM408	1	Flywheel Cover	
9	PELM800	1	Platform Tray	
10	PELM409	2	Front Cone Rubber Buffer	
11	PELM410JO	1	Left-hand Guardrail	
12	PELM411JO	1	Right-hand Guardrail	
13	PELM412	1	Handle Knob	
14	PELM413	2	Brake Cam	
15	PELM414	2	Brake Plunger Spring	
16	PELM415	2	Brake Pin	
17	PELM416	1	Roller Cover	
18	PTNSPM683	1	Roller c/w Bearings	
19	PELM417	1	Castor Spring	
20	PELM418	2	Gate Spring	
21	PELM407	1	Emergency Lowering Tool	
22	PELM419JC	1	Mast Complete	
23	PELM420	1	Mast Cap	
24	PELM421JC	1	Mast Interlock	
25		Ref	Screw	
26		Ref	Screw	
27		Ref	Spacer	
28		Ref	Screw	
29		Ref	Screw	
30		Ref	Screw	
31		Ref	Screw	
32		Ref	Screw	
33		Ref	Nut	
34		Ref	Nylocknut	
35		Ref	Screw	
36		Ref	Screw	
37		Ref	Screw	
38		Ref	Screw	
39		Ref	Rod	
40		Ref	O-Ring	
41		Ref	Pin	
42		Ref	Screw	
43		Ref	Screw	
44		Ref	Nut	
45		Ref	Washer	
46		Ref	Nut	
47		Ref	Screw	
48		Ref	Washer	
49		Ref	Nut	
50		Ref	Cover	

## SECTION 1 - ECOLIFT50

ITEM	PART NUMBER	QTY	DESCRIPTION	REV
51		Ref	Frame	
52		Ref	Washer	
53		Ref	Nut	
54		Ref	Plate	
55		Ref	Plate	
56	1001214127	1	Manual Holder	
57	PTM106	1	Indicator, Level	



# SECTION 1 - ECOLIFT50

## FIGURE 1-2. DECAL INSTALLATION (ANSI)

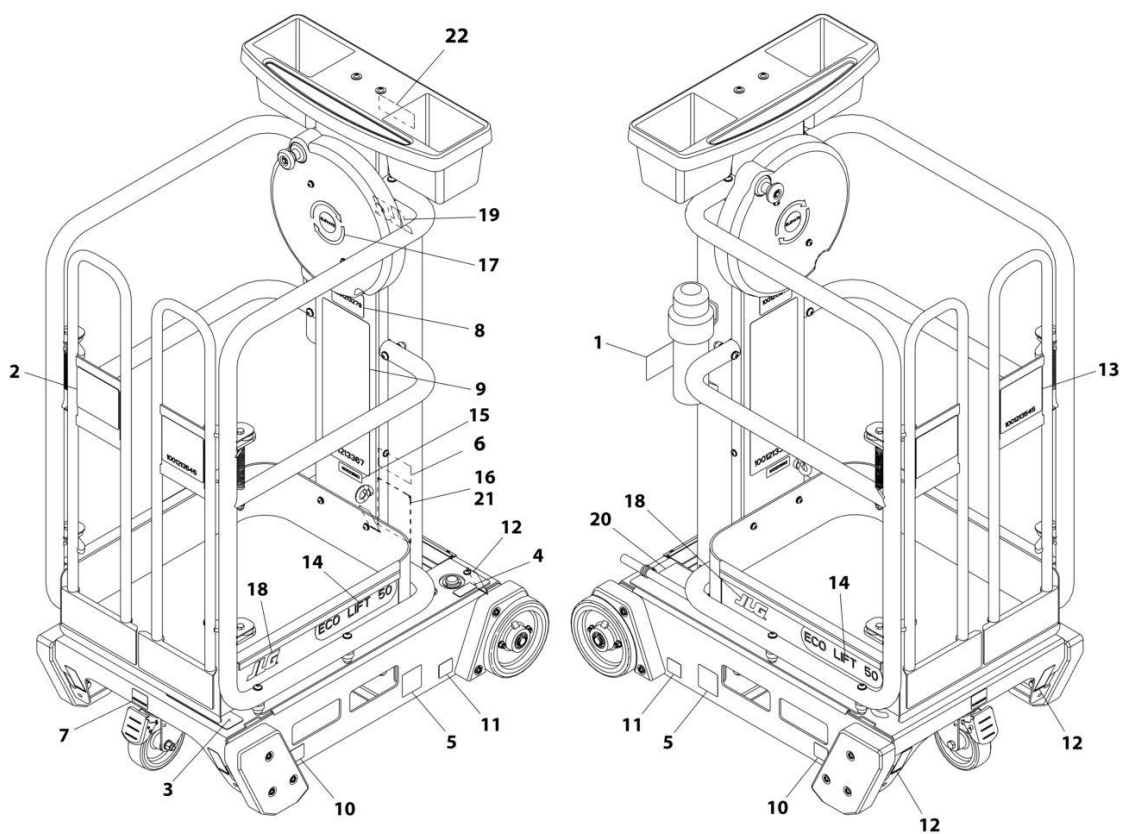

ART\_1001213427

## SECTION 1 - ECOLIFT50

**FIGURE 1-2. DECAL INSTALLATION (ANSI)**

ITEM	PART NUMBER	QTY	DESCRIPTION	REV
	1001213427	Ref	DECAL INSTALLATION (ANSI)	C
1	1701509	1	Decal - Manual	
2	1703781	1	Decal - Electrical Hazard	
3	1703786	1	Decal - Crushing Hazard	
4	1703789	1	Decal - Level Indicator	
5	1703817	2	Decal - Fork Lift	
6	1706351	1	Decal - CSA (SN P900000109 to Present)	
7	1001213208	1	Decal - Caster Lock	
8	1001213279	1	Decal - Capacity	
9	1001213367	1	Decal - Warning	
10	1001213439	2	Decal - Wheel Pad Load	
11	1001213440	2	Decal - Wheel Load	
12	1001213442	4	Decal - Tie Down/Lift	
13	1001213545	1	Decal - Crushing Tipping	
14	1001213548	2	Decal - Ecolift 50	
15	1001213582	1	Decal - Lanyard Attach Graphic	
16	See Note	NSS	Nameplate - Manufacture (Note: Not Available for Purchase)	
17	1001213997	1	Decal - Elevate Crank	
18	1001214108	2	Decal - JLG 4.3125	
19	1001214109	1	Decal - JLG 5.125	
20	1001214125	1	Decal - Manual Descent	
21	3820001	4	Rivet	
22	1001215043	1	Decal - Warning Label	

# SECTION 1 - ECOLIFT50

## FIGURE 1-3. DECAL INSTALLATION (CSA/FRE)

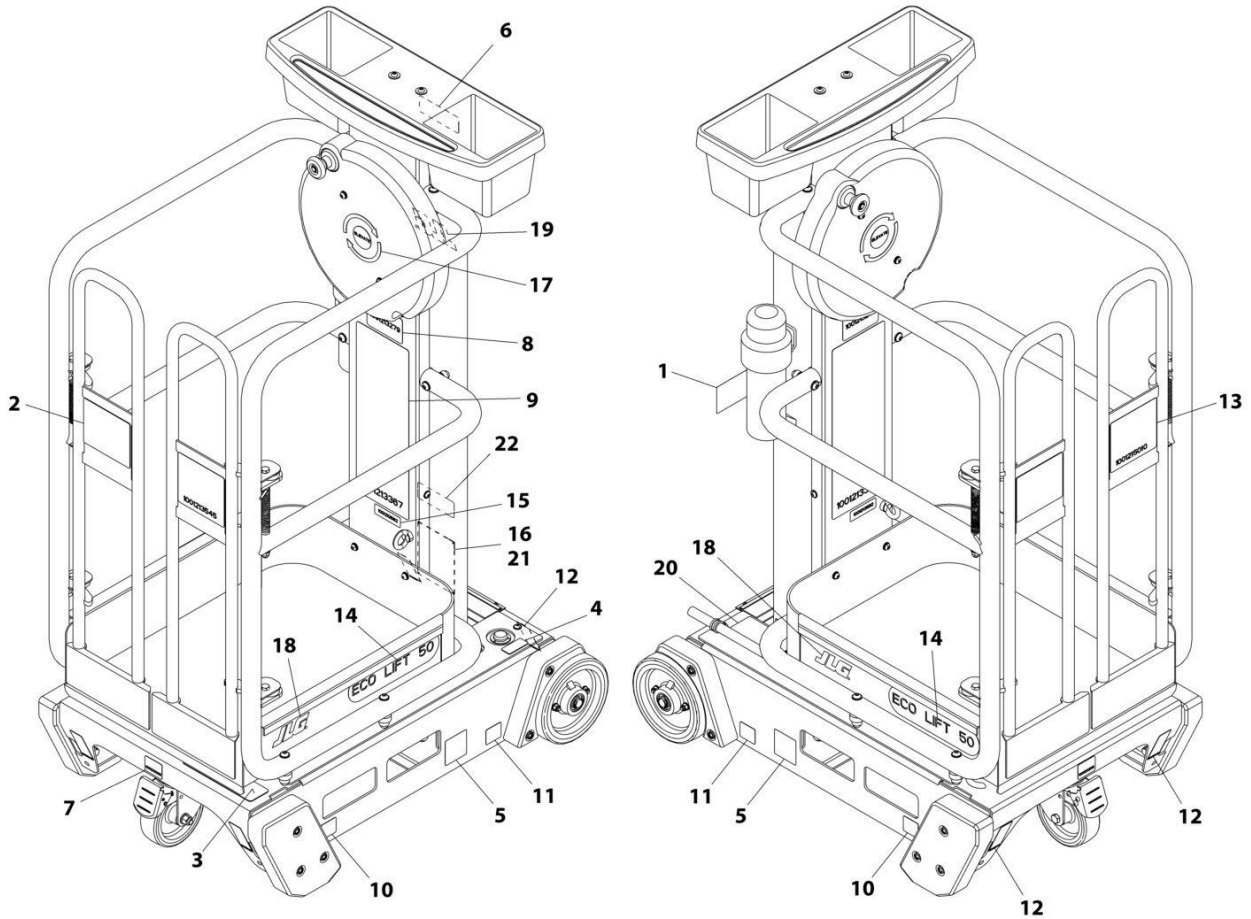

ART\_1001215011



## SECTION 1 - ECOLIFT50

**FIGURE 1-3. DECAL INSTALLATION (CSA/FRE)**

ITEM	PART NUMBER	QTY	DESCRIPTION	REV
	1001215011	Ref	DECAL INSTALLATION (CSA/FRE)	A
1	1701509	1	Decal - Manual	
2	1704795	1	Decal - Electrical Hazard	
3	1704039	1	Decal - Crushing Hazard	
4	1704041	1	Decal - Level Indicator	
5	1703817	2	Decal - Fork Lift	
6	1001215049	1	Decal - Warning Label	
7	1001213208	1	Decal - Caster Lock	
8	1001213279	1	Decal - Capacity	
9	1001215007	1	Decal - Warning	
10	1001213439	2	Decal - Wheel Pad Load	
11	1001213440	2	Decal - Wheel Load	
12	1001213442	4	Decal - Tie Down/Lift	
13	1001215010	1	Decal - Crushing Tipping	
14	1001213548	2	Decal - Ecolift 50	
15	1001213582	1	Decal - Lanyard Attach Graphic	
16	See Note	NSS	Nameplate - Manufacture (Note: Not Available for Purchase)	
17	1001213997	1	Decal - Elevate Crank	
18	1001214108	2	Decal - JLG 4.3125	
19	1001214109	1	Decal - JLG 5.125	
20	1001214125	1	Decal - Manual Descent	
21	3820001	4	Rivet	
22	1706351	1	Decal - CSA	

# SECTION 1 - ECOLIFT50

## FIGURE 1-4. DECAL INSTALLATION (PORTUGUESE)

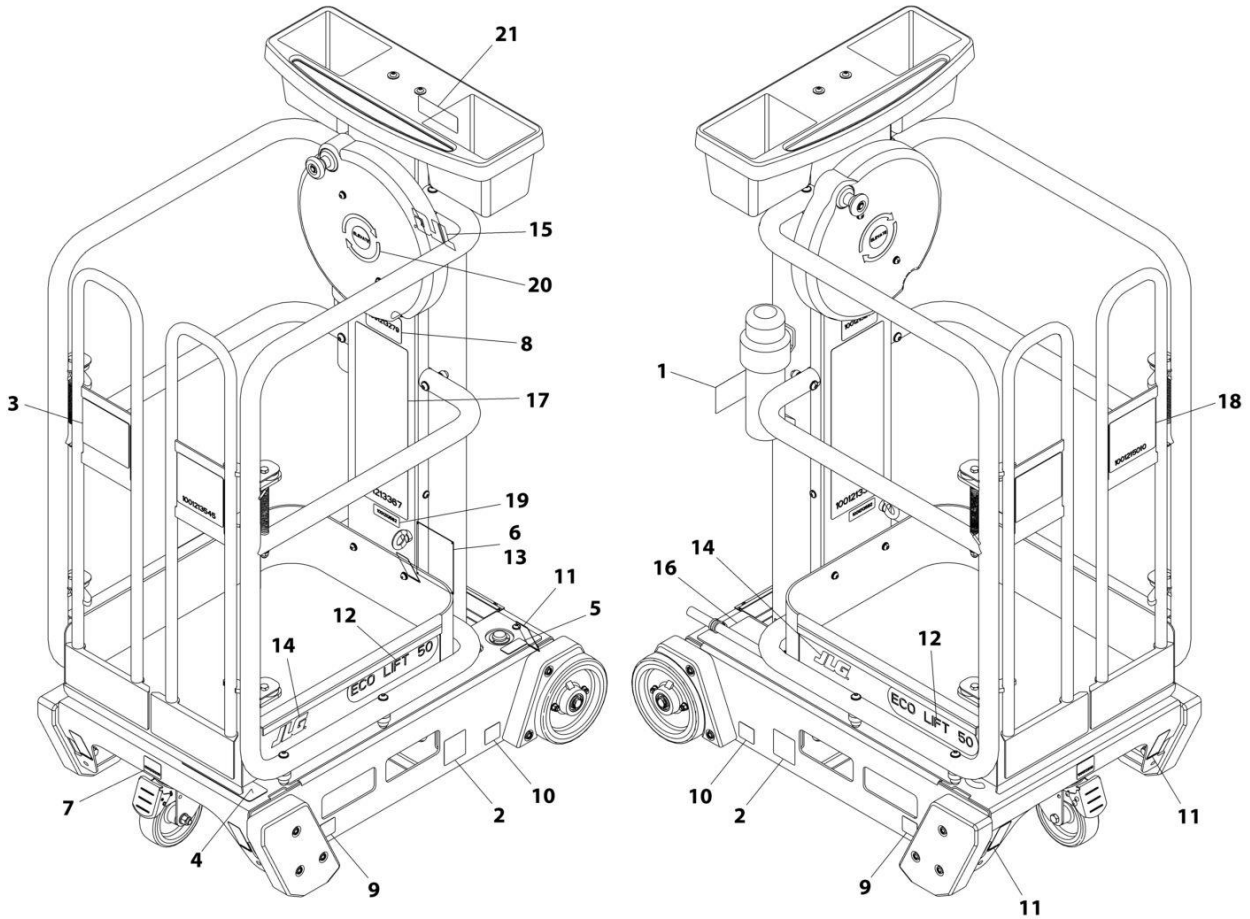

ART\_1001241786

## SECTION 1 - ECOLIFT50

**FIGURE 1-4. DECAL INSTALLATION (PORTUGUESE)**

ITEM	PART NUMBER	QTY	DESCRIPTION	REV
	1001241786	Ref	DECAL INSTALLATION (PORTUGUESE)	A
1	1701509	1	Decal - Manual	
2	1703817	2	Decal - Fork Lift	
3	1704021	1	Decal - Electrical Hazard	
4	1704024	1	Decal - Crushing Hazard	
5	1704026	1	Decal - Level Indicator	
6	3820001	4	Rivet	
7	1001213208	1	Decal - Caster Lock	
8	1001213279	1	Decal - Capacity	
9	1001213439	2	Decal - Wheel Pad Load	
10	1001213440	2	Decal - Wheel Load	
11	1001213442	4	Decal - Tie Down/Lift	
12	1001213548	2	Decal - Ecolift 50	
13	See Note	NSS	Nameplate - Manufacture (Note: Not Available for Purchase)	
14	1001214108	2	Decal - JLG 4.3125	
15	1001214109	1	Decal - JLG 5.125	
16	1001214125	1	Decal - Manual Descent	
17	1001241800	1	Decal - Warning	
18	1001241801	1	Decal - Crushing Tipping	
19	1001241802	1	Decal - Lanyard Attach Graphic	
20	1001241803	1	Decal - Elevate Crank	
21	1001241804	1	Decal - Warning Label	

# SECTION 1 - ECOLIFT50

## FIGURE 1-5. DECAL INSTALLATION (SPANISH)

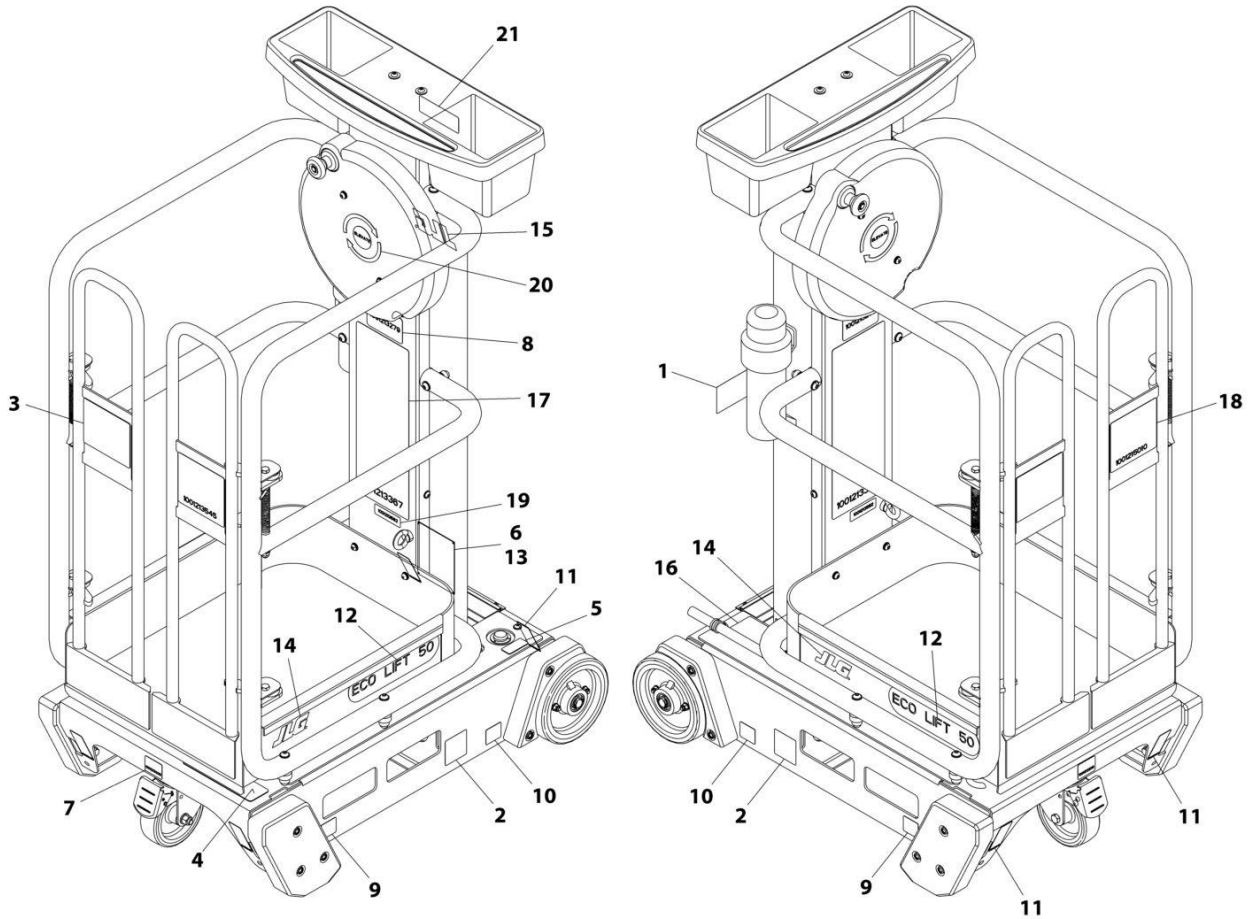

ART\_1001241784

## SECTION 1 - ECOLIFT50

**FIGURE 1-5. DECAL INSTALLATION (SPANISH)**

ITEM	PART NUMBER	QTY	DESCRIPTION	REV
	1001241784	Ref	DECAL INSTALLATION (SPANISH)	A
1	1701509	1	Decal - Manual	
2	1703817	2	Decal - Fork Lift	
3	1704029	1	Decal - Electrical Hazard	
4	1704032	1	Decal - Crushing Hazard	
5	1704034	1	Decal - Level Indicator	
6	3820001	4	Rivet	
7	1001213208	1	Decal - Caster Lock	
8	1001213279	1	Decal - Capacity	
9	1001213439	2	Decal - Wheel Pad Load	
10	1001213440	2	Decal - Wheel Load	
11	1001213442	4	Decal - Tie Down/Lift	
12	1001213548	2	Decal - Ecolift 50	
13	See Note	NSS	Nameplate - Manufacture (Note: Not Available for Purchase)	
14	1001214108	2	Decal - JLG 4.3125	
15	1001214109	1	Decal - JLG 5.125	
16	1001214125	1	Decal - Manual Descent	
17	1001241790	1	Decal - Warning	
18	1001241791	1	Decal - Crushing Tipping	
19	1001241792	1	Decal - Lanyard Attach Graphic	
20	1001241793	1	Decal - Elevate Crank	
21	1001241794	1	Decal - Warning Label	

## SECTION 1 - ECOLIFT50

FIGURE 1-6. RECOMMENDED SERVICE PARTS STOCK

ITEM	PART NUMBER	QTY	DESCRIPTION	REV
		Ref	Note: The following list will service one machine (built to current production per date on the front cover) with emergency repair parts which can be installed in the field. Parts from the list should be replaced when inventory is depleted to keep service parts stock supplied. For further information, contact your JLG dealer or the JLG Industries Parts Department.	
	PELM407	Ref 1	STANDARD PARTS Emergency Lowering Tool	



## SECTION 1 - ECOLIFT50

**FIGURE 1-7. SPECIAL OPTIONS**

ITEM	PART NUMBER	QTY	DESCRIPTION	REV
	Note	Ref	Note: This list is to accommodate machines ordered with special equipment. Options may not be applicable to all models. For more specific parts information contact JLG Parts Department.	
		Ref	MISCELLANEOUS SPECIAL OPTIONS	
	1001224466	Ref	Atex Kit (ECOLIFT 50)	
	1001227778	Ref	Decal Kit - Blueline	
	1001221975	Ref	Decal - Herc Rental (ECOLIFT 50)	
	1001221996	Ref	Decal - Sunbelt Rental (ECOLIFT 50)	



**SECTION 2 - ECOLIFT70**

# SECTION 2 - ECOLIFT70

## FIGURE 2-1. COMPONENTS

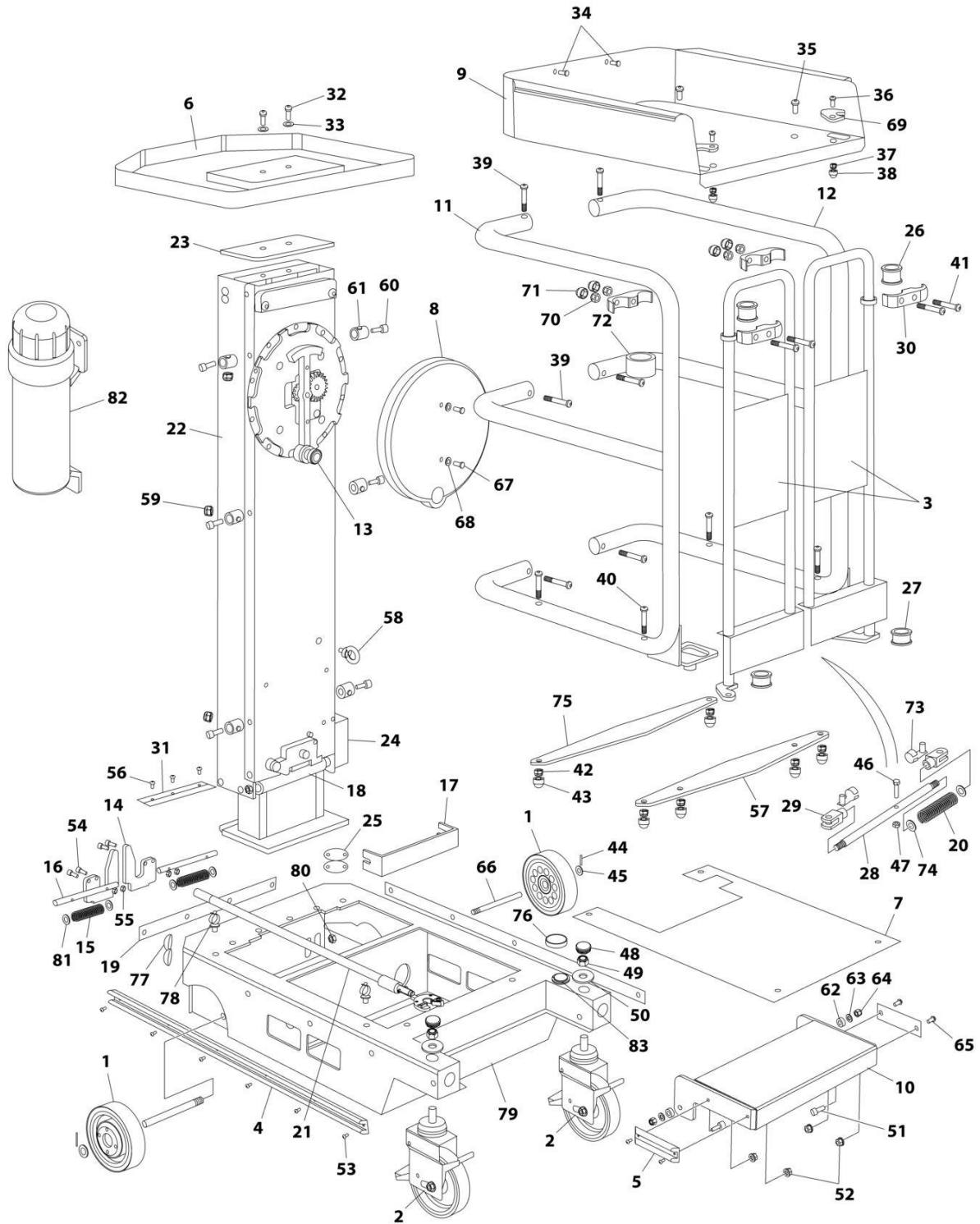

ART\_Ecolift70\_1

FIGURE 2-1. COMPONENTS

ITEM	PART NUMBER	QTY	DESCRIPTION	REV
1	ECLM600	2	Wheel/Brake Sprocket	
2	PTM1022	2	Swivel Castor c/w Fixings	
3	ECLM700JO	1	Gates (pair)	
4	ECLM604	2	Side Buffer	
5	ECLM605	2	Step Buffer	
6	ECLM601JO	1	Tool Tray	
7	ECLM602	1	Chassis Cover	
8	ECLM603	1	Flywheel Cover	
9	ECLM704	1	Platform Tray	
10	ECLM701	1	Step	
11	ECLM705JO	1	Left-hand Guardrail	
12	ECLM706JO	1	Right-hand Guardrail	
13	PELM412	1	Handle Knob	
14	ECLM616	2	Reinforced Brake Cam	
15	PELM414	2	Brake Plunger Spring	
16	ECLM606	2	Brake Pin	
17	ECLM702	1	Roller Cover	
18	ECLM607	1	Roller c/w Bearings	
19	ECLM608	1	Rear Buffer	
20	ECLM609	1	Gate Spring	
21	ECLM703	1	Emergency Lowering Tool	
22	ECLM707JC	1	Mast Complete	
23	ECLM708	1	Mast Cap	
24	PELM421JC	1	Mast Interlock Cover	
25	ECLM611	2	Corner Buffer	
26	ECLM612	2	Hinge Top Bush	
27	ECLM413	2	Hinge Lower Bush	
28	ECLM709	1	Link Bar	
29	ECLM613	2	Clevis	
30	ECLM710JO	4	Hinge Bracket	
31	ECLM614	1	Brush	
32		Ref	Screw	
33		Ref	Washer	
34		Ref	Screw	
35		Ref	Screw	
36		Ref	Screw	
37		Ref	Nut	
38		Ref	Nylocknut	
39		Ref	Screw	
40		Ref	Screw	
41		Ref	Screw	
42		Ref	Nut	
43		Ref	Nylocknut	
44		Ref	Pin	
45		Ref	O-Ring	
46		Ref	Bolt	
47		Ref	Nut	
48		Ref	Cap	
49		Ref	Nut	
50		Ref	Washer	

## SECTION 2 - ECOLIFT70

ITEM	PART NUMBER	QTY	DESCRIPTION	REV
51		Ref	Screw	
52		Ref	Nut	
53		Ref	Screw	
54		Ref	Screw	
55		Ref	Nut	
56		Ref	Screw	
57		Ref	Plate	
58		Ref	Lifting Eye	
59		Ref	Nut	
60		Ref	Screw	
61		Ref	Spacer	
62		Ref	Spacer	
63		Ref	Washer	
64		Ref	Nut	
65		Ref	Screw	
66		Ref	Rod	
67		Ref	Screw	
68		Ref	Washer	
69		Ref	Plate	
70		Ref	Nut	
71		Ref	Nylocknut	
72		Ref	Spacer	
73		Ref	Clamp	
74		Ref	Washer	
75		Ref	Plate	
76		Ref	Plug	
77		Ref	Bumper	
78		Ref	Clamp	
79		Ref	Frame	
80		Ref	Nut	
81		Ref	Washer	
82	1001214127	1	Manual Holder	
83	PELM451	1	Indicator, Level	



# SECTION 2 - ECOLIFT70

## FIGURE 2-2. DECAL INSTALLATION (ANSI)

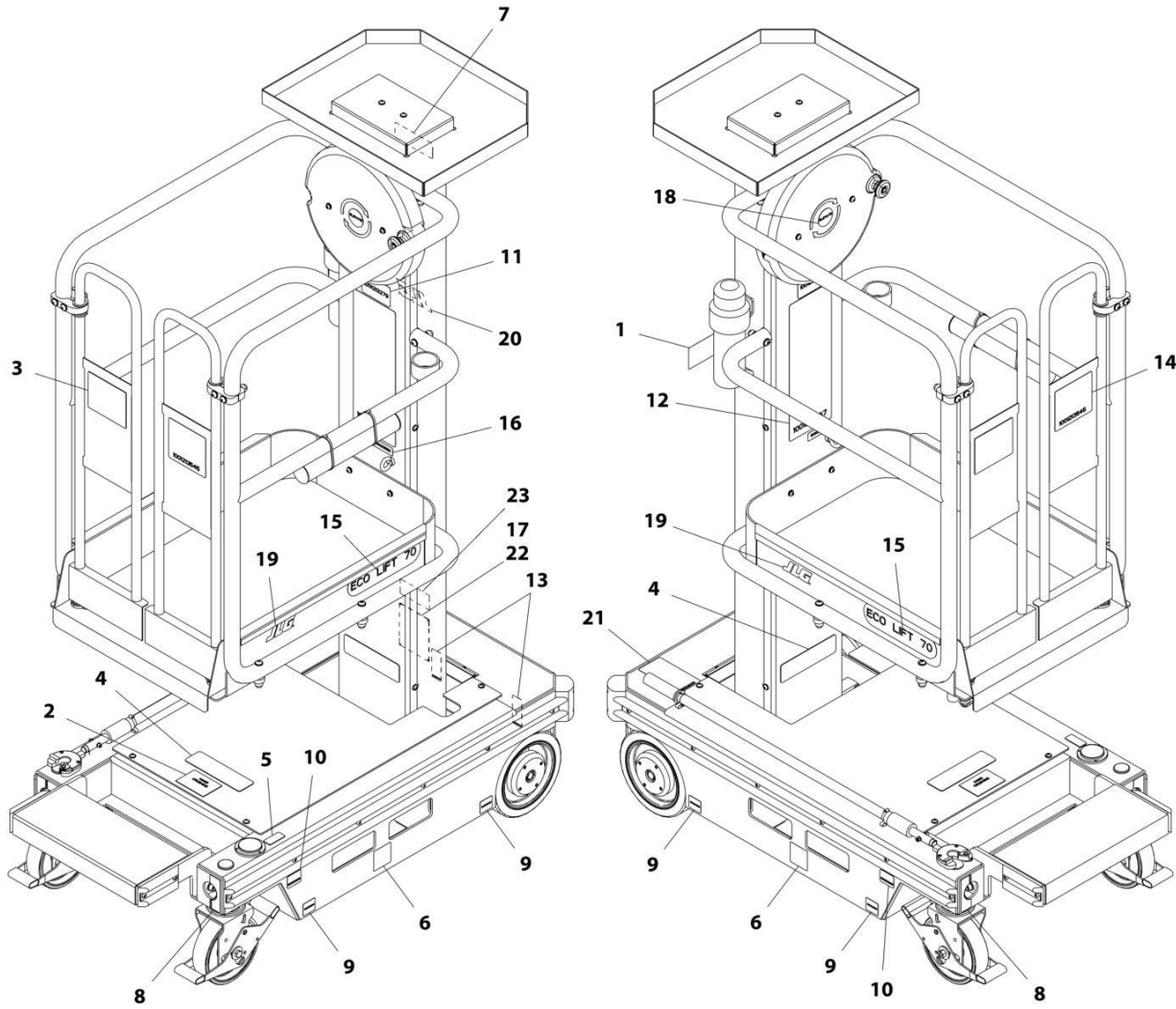

ART\_1001213185

FIGURE 2-2. DECAL INSTALLATION (ANSI)

ITEM	PART NUMBER	QTY	DESCRIPTION	REV
	1001213185	Ref	DECAL INSTALLATION (ANSI)	D
1	1701509	1	Decal - Manual	
2	1702391	1	Decal - Hand Crushing	
3	1703781	1	Decal - Electrical Hazard	
4	1703786	2	Decal - Crushing Hazard	
5	1703789	1	Decal - Level Indicator	
6	1703817	2	Decal - Fork Lift	
7	1001215043	1	Decal - Warning Label	
8	1001213202	1	Decal - Tie Down/Lift	
9	1001213205	4	Decal - Wheel Load	
10	1001213208	2	Decal - Caster Lock	
11	1001213279	1	Decal - Capacity	
12	1001213367	1	Decal - Warning	
13	1001213442	2	Decal - Tie Down/Lift	
14	1001213545	1	Decal - Crushing Tipping	
15	1001213549	2	Decal - Ecolift 50	
16	1001213582	1	Decal - Lanyard Attach Graphic	
17	See Note	NSS	Nameplate - Manufacture (Note: Not Available for Purchase)	
18	1001213997	1	Decal - Elevate Crank	
19	1001214108	2	Decal - JLG 4.3125	
20	1001214109	1	Decal - JLG 5.125	
21	1001214125	1	Decal - Manual Descent	
22	3820001	4	Rivet	
23	1706351	1	Decal - CSA	

# SECTION 2 - ECOLIFT70

## FIGURE 2-3. DECAL INSTALLATION (CSA/FRE)

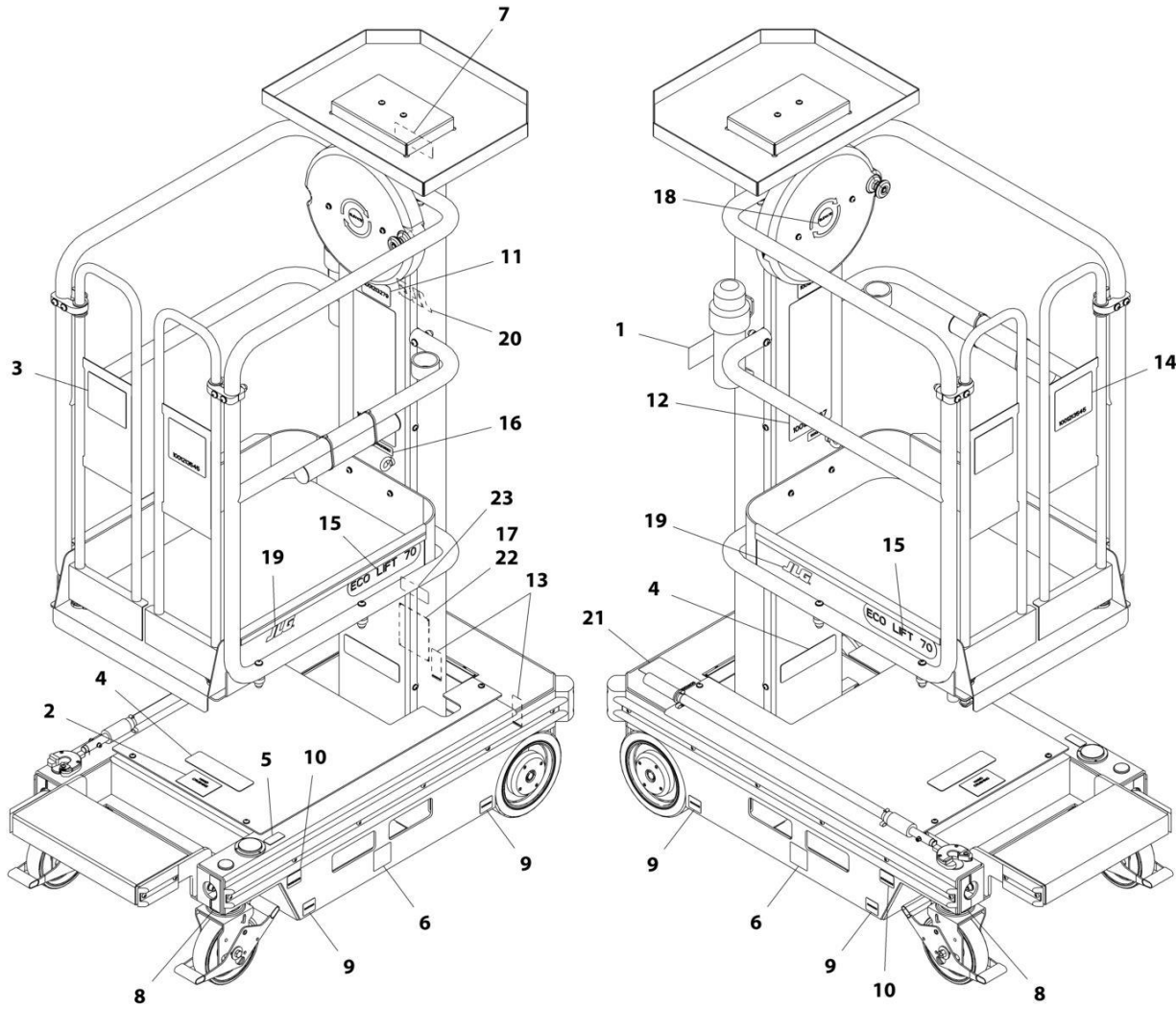

ART\_1001215012

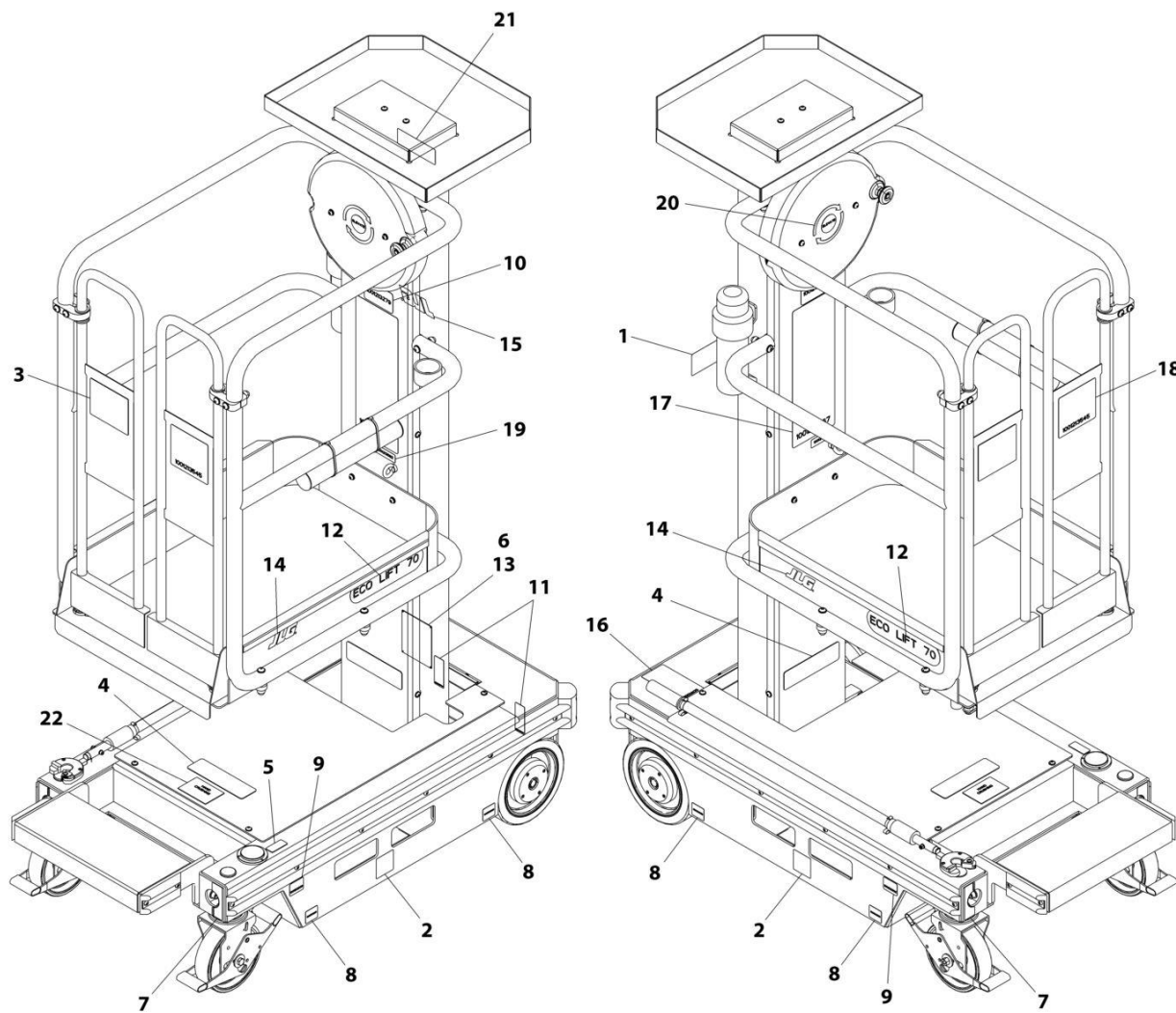

FIGURE 2-3. DECAL INSTALLATION (CSA/FRE)

ITEM	PART NUMBER	QTY	DESCRIPTION	REV
	1001215012	Ref	DECAL INSTALLATION (CSA/FRE)	A
1	1701509	1	Decal - Manual	
2	1001215113	1	Decal - Hand Crushing	
3	1704795	1	Decal - Electrical Hazard	
4	1704039	2	Decal - Crushing Hazard	
5	1704041	1	Decal - Level Indicator	
6	1703817	2	Decal - Fork Lift	
7	1001215049	1	Decal - Warning Label	
8	1001213202	1	Decal - Tie Down/Lift	
9	1001213205	4	Decal - Wheel Load	
10	1001213208	2	Decal - Caster Lock	
11	1001213279	1	Decal - Capacity	
12	1001215007	1	Decal - Warning	
13	1001213442	2	Decal - Tie Down/Lift	
14	1001215010	1	Decal - Crushing Tipping	
15	1001213549	2	Decal - Ecolift 70	
16	1001215009	1	Decal - Lanyard Attach Graphic	
17	See Note	NSS	Nameplate - Manufacture (Note: Not Available for Purchase)	
18	1001215005	1	Decal - Elevate Crank	
19	1001214108	2	Decal - JLG 4.3125	
20	1001214109	1	Decal - JLG 5.125	
21	1001214125	1	Decal - Manual Descent	
22	3820001	4	Rivet	
23	1706351	1	Decal - CSA	

# SECTION 2 - ECOLIFT70

## FIGURE 2-4. DECAL INSTALLATION (PORTUGUESE)



ART\_1001241787

**FIGURE 2-4. DECAL INSTALLATION (PORTUGUESE)**

<b>ITEM</b>	<b>PART NUMBER</b>	<b>QTY</b>	<b>DESCRIPTION</b>	<b>REV</b>
	1001241787	Ref	DECAL INSTALLATION (PORTUGUESE)	A
1	1701509	1	Decal - Manual	
2	1703817	2	Decal - Fork Lift	
3	1704021	1	Decal - Electrical Hazard	
4	1704024	2	Decal - Crushing Hazard	
5	1704026	1	Decal - Level Indicator	
6	3820001	4	Rivet	
7	1001213202	1	Decal - Tie Down/Lift	
8	1001213205	4	Decal - Wheel Load	
9	1001213208	2	Decal - Caster Lock	
10	1001213279	1	Decal - Capacity	
11	1001213442	2	Decal - Tie Down/Lift	
12	1001213549	2	Decal - Ecolift 70	
13	See Note	NSS	Nameplate - Manufacture (Note: Not Available for Purchase)	
14	1001214108	2	Decal - JLG 4.3125	
15	1001214109	1	Decal - JLG 5.125	
16	1001214125	1	Decal - Manual Descent	
17	1001241800	1	Decal - Warning	
18	1001241801	1	Decal - Crushing Tipping	
19	1001241802	1	Decal - Lanyard Attach Graphic	
20	1001241803	1	Decal - Elevate Crank	
21	1001241804	1	Decal - Warning Label	
22	1001241805	1	Decal - Hand Crushing	

# SECTION 2 - ECOLIFT70

## FIGURE 2-5. DECAL INSTALLATION (SPANISH)

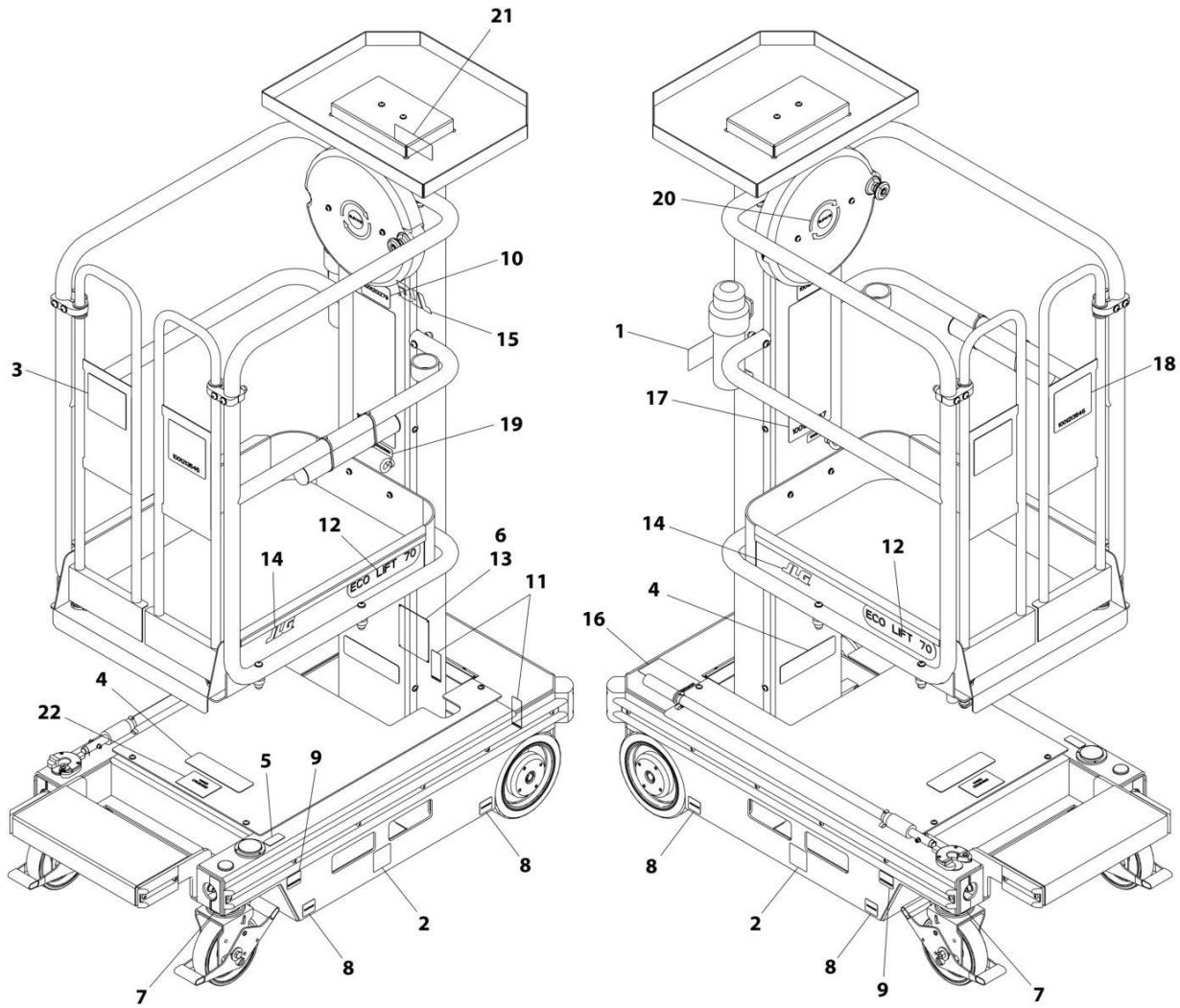

ART\_1001241785

FIGURE 2-5. DECAL INSTALLATION (SPANISH)

ITEM	PART NUMBER	QTY	DESCRIPTION	REV
	1001241785	Ref	DECAL INSTALLATION (SPANISH)	A
1	1701509	1	Decal - Manual	
2	1703817	2	Decal - Fork Lift	
3	1704029	1	Decal - Electrical Hazard	
4	1704032	2	Decal - Crushing Hazard	
5	1704034	1	Decal - Level Indicator	
6	3820001	4	Rivet	
7	1001213202	1	Decal - Tie Down/Lift	
8	1001213205	4	Decal - Wheel Load	
9	1001213208	2	Decal - Caster Lock	
10	1001213279	1	Decal - Capacity	
11	1001213442	2	Decal - Tie Down/Lift	
12	1001213549	2	Decal - Ecolift 70	
13	See Note	NSS	Nameplate - Manufacture (Note: Not Available for Purchase)	
14	1001214108	2	Decal - JLG 4.3125	
15	1001214109	1	Decal - JLG 5.125	
16	1001214125	1	Decal - Manual Descent	
17	1001241790	1	Decal - Warning	
18	1001241791	1	Decal - Crushing Tipping	
19	1001241792	1	Decal - Lanyard Attach Graphic	
20	1001241793	1	Decal - Elevate Crank	
21	1001241794	1	Decal - Warning Label	
22	1001241795	1	Decal - Hand Crushing	

## SECTION 2 - ECOLIFT70

**FIGURE 2-6. RECOMMENDED SERVICE PARTS STOCK**

ITEM	PART NUMBER	QTY	DESCRIPTION	REV
		Ref	Note: The following list will service one machine (built to current production per date on the front cover) with emergency repair parts which can be installed in the field. Parts from the list should be replaced when inventory is depleted to keep service parts stock supplied. For further information, contact your JLG dealer or the JLG Industries Parts Department.	
	ECLM703	Ref 1	STANDARD PARTS Emergency Lowering Tool	



## SECTION 2 - ECOLIFT70

**FIGURE 2-7. SPECIAL OPTIONS**

ITEM	PART NUMBER	QTY	DESCRIPTION	REV
	Note	Ref	Note: This list is to accommodate machines ordered with special equipment. Options may not be applicable to all models. For more specific parts information contact JLG Parts Department.	
		Ref	MISCELLANEOUS SPECIAL OPTIONS	
	1001226127	Ref	Atex Kit (ECOLIFT 70)	
	1001227778	Ref	Decal Kit - Blueline	
	1001221976	Ref	Decal - Herc Rental (ECOLIFT 70)	
	1001221997	Ref	Decal - Sunbelt Rental (ECOLIFT 70)	



**SECTION 3 - 830P**

# SECTION 3 - 830P

## FIGURE 3-1. CHASSIS AND MAST COMPONENTS

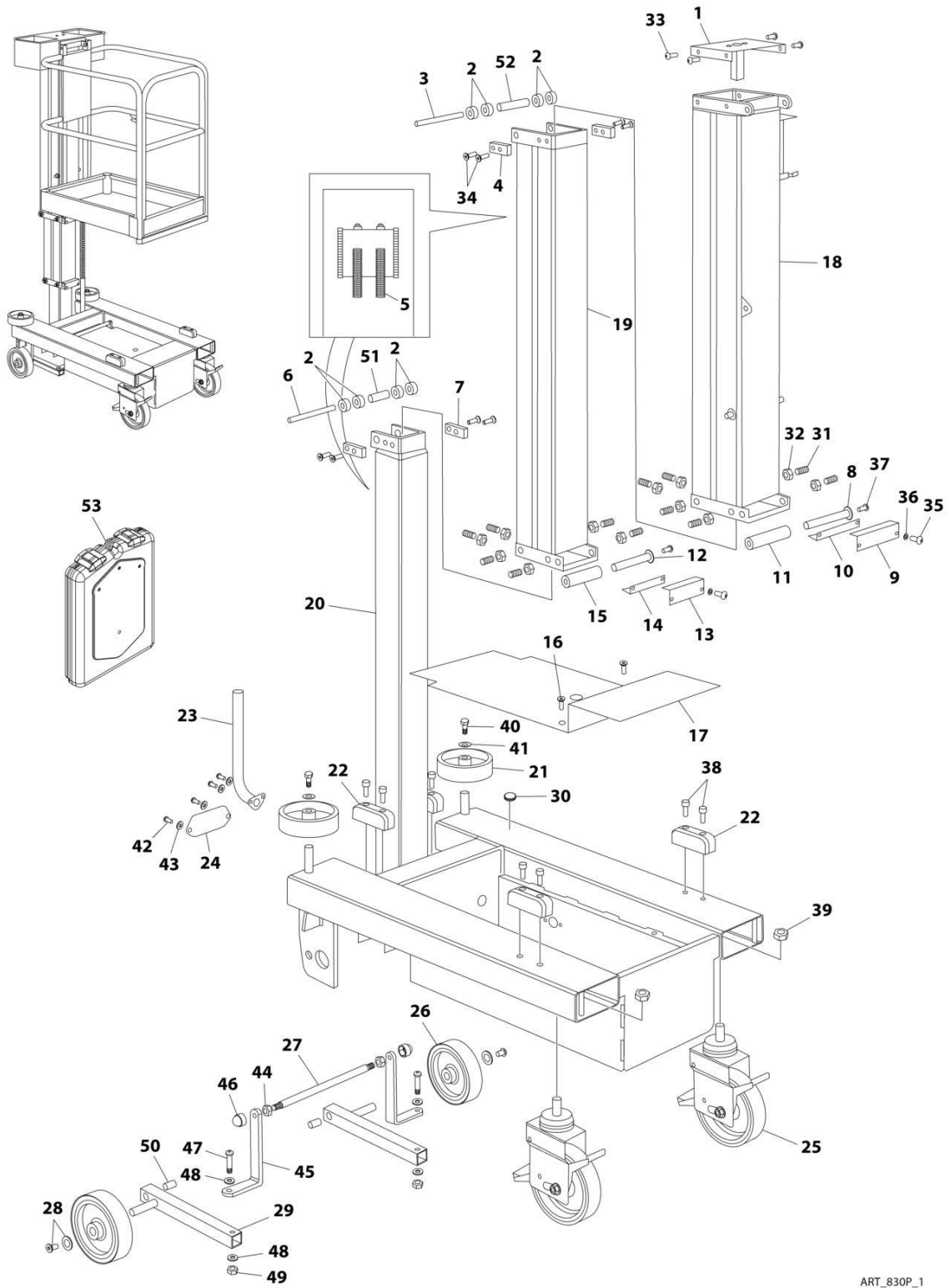

ART\_830P\_1

FIGURE 3-1. CHASSIS AND MAST COMPONENTS

ITEM	PART NUMBER	QTY	DESCRIPTION	REV
1	PTNM348JC	1	Mast Cap	
2	PTNM356	8	Inner Roller	
3	PTNM357	1	Axle 170mm LG	
4	PTNM358	2	Wear Pad	
5	PTNM360	2	Mast Spring	
6	PTNM359	1	Axle 140mm LG	
7	PTNM358	2	Wear Pad	
8	PTNM361	1	Axle 192mm LG	
9	PTNM365AJC	1	Cover 157mm LG	
10	PTNM363A	1	Brush 157mm LG	
11	PTNM364	1	Roller Outer Mast	
12	PTNM366	1	Axle 164mm LG	
13	PTNM365BJC	1	Cover 127mm LG	
14	PTNM363B	1	Brush 127mm LG	
15	PTNM367	1	Roller Middle Mast	
16	PTM107	1	Cover Securing Knob	
17	PTNM320JO	1	Checkerplate Cover	
18	PTNM329JC	1	Outer Mast	
19	PTNM349JC	1	Middle Mast	
20	PTNM368JO	1	Chassis Frame	
21	PTNM302	2	Buffer Wheel	
22	PTM126	4	Rubber Buffer	
23	PTNM321JO	1	Susie Guide Tube	
24	PTNM369	1	End Cover	
25	PTM1022	2	Swivel Castor c/w Fixings	
26	PTM103	2	Fixed Wheel	
27	PTNM380	1	Brake Roller	
28	PTNM392C	2	Wheel Fixing	
29	PTNM385JO	2	Axle Arm	
30	PTM106	1	Spirit Level	
31	PTNM390	12	Wear Screw	
32	PTNM391	12	Locknut M24	
33		Ref	Screw	
34		Ref	Screw	
35		Ref	Screw	
36		Ref	Washer	
37		Ref	Screw	
38		Ref	Screw	
39		Ref	Nut	
40		Ref	Screw	
41		Ref	Washer	
42		Ref	Screw	
43		Ref	Washer	
44		Ref	Nut	
45		Ref	Bracket	
46		Ref	Nut	
47		Ref	Bolt	
48		Ref	Washer	
49		Ref	Nut	
50		Ref	Bushing	

## SECTION 3 - 830P

ITEM	PART NUMBER	QTY	DESCRIPTION	REV
51		Ref	Roller	
52		Ref	Roller	
53	PTNM342	1	Manual Holder	



# SECTION 3 - 830P

## FIGURE 3-2. PLATFORM COMPONENTS

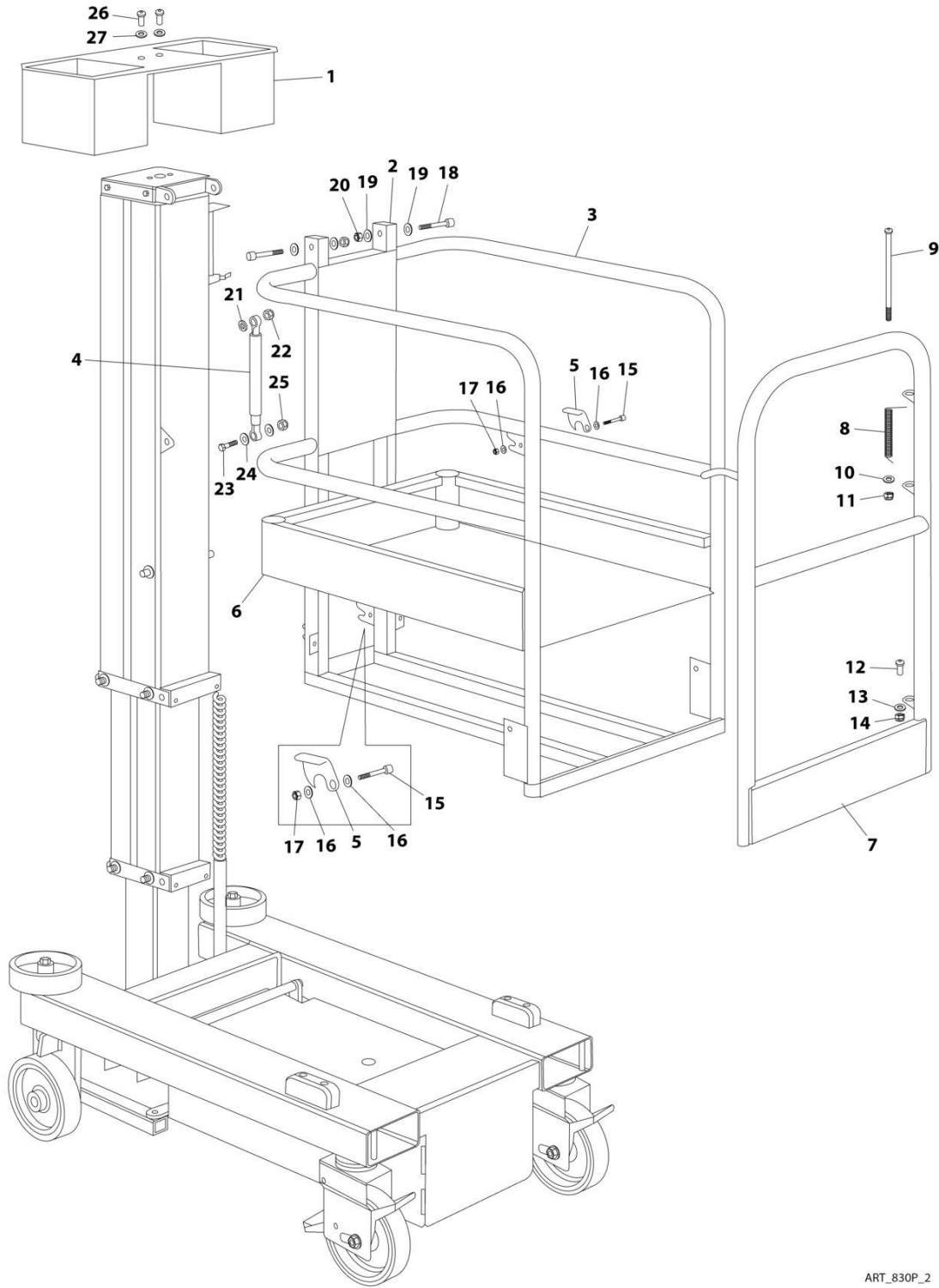

ART\_830P\_2

FIGURE 3-2. PLATFORM COMPONENTS

ITEM	PART NUMBER	QTY	DESCRIPTION	REV
1	PELM405	1	Tool Tray (Shown)	
1	PTNM303	1	Tool Tray (Not Shown)	
2	PTNM305	1	Cage Pivot Bush	
3	PTNM350JO	1	Guardrails Complete	
4	PTNM340	1	Gas Strut	
5	PTM133	2	Gate Latch c/w Fixings	
6	PTNM355	1	Platform Aluminum Tray	
7	PTNM351JO	1	Gate Hoop	
8	PTNM352	1	Gate Spring	
9		Ref	Screw	
10		Ref	Washer	
11		Ref	Nut	
12		Ref	Screw	
13		Ref	Washer	
14		Ref	Nut	
15		Ref	Screw	
16		Ref	Washer	
17		Ref	Nut	
18		Ref	Screw	
19		Ref	Washer	
20		Ref	Nut	
21		Ref	Washer	
22		Ref	Nut	
23		Ref	Screw	
24		Ref	Washer	
25		Ref	Nut	
26		Ref	Screw	
27		Ref	Washer	

# SECTION 3 - 830P

## FIGURE 3-3. ELECTRICAL AND HYDRAULIC COMPONENTS

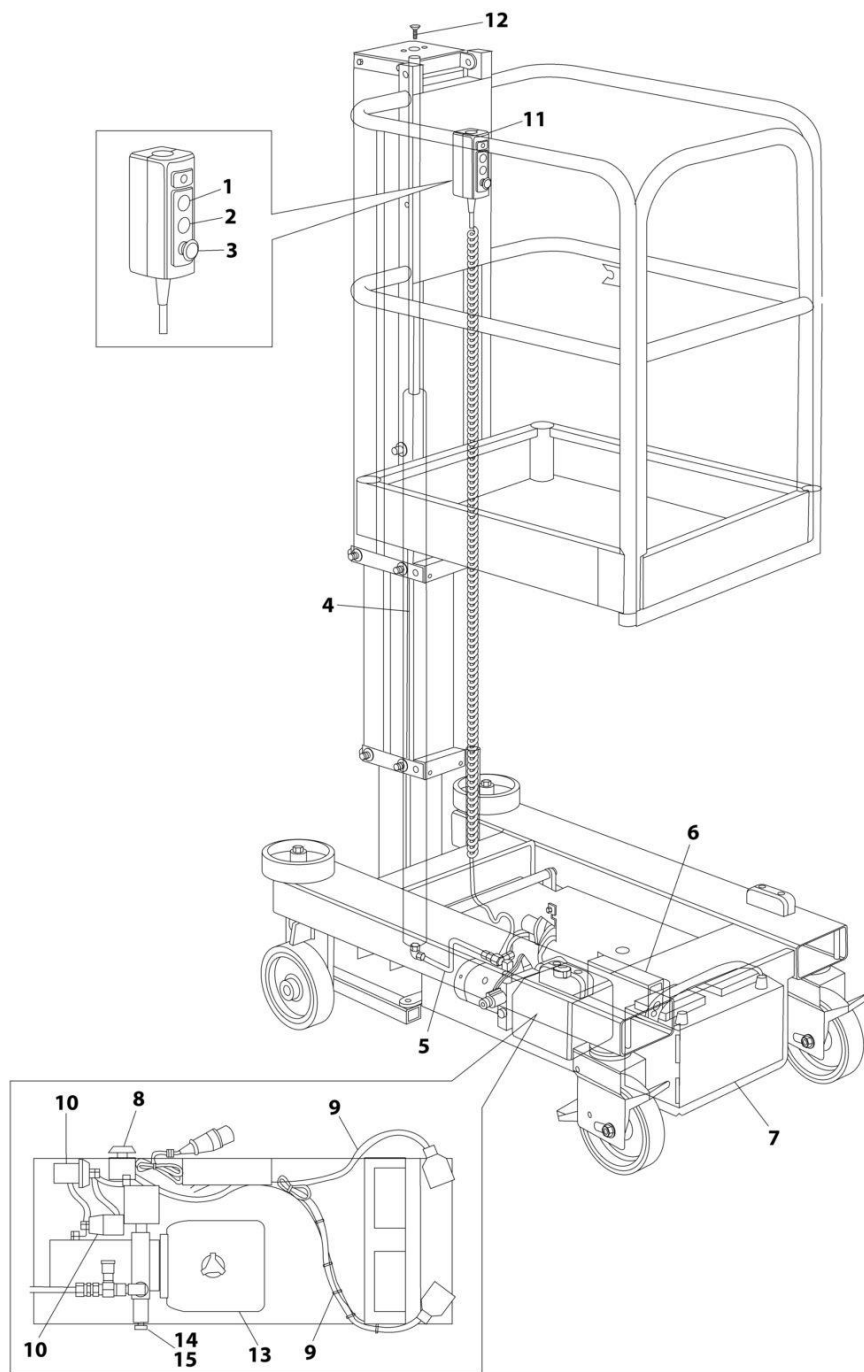

ART\_830P\_3

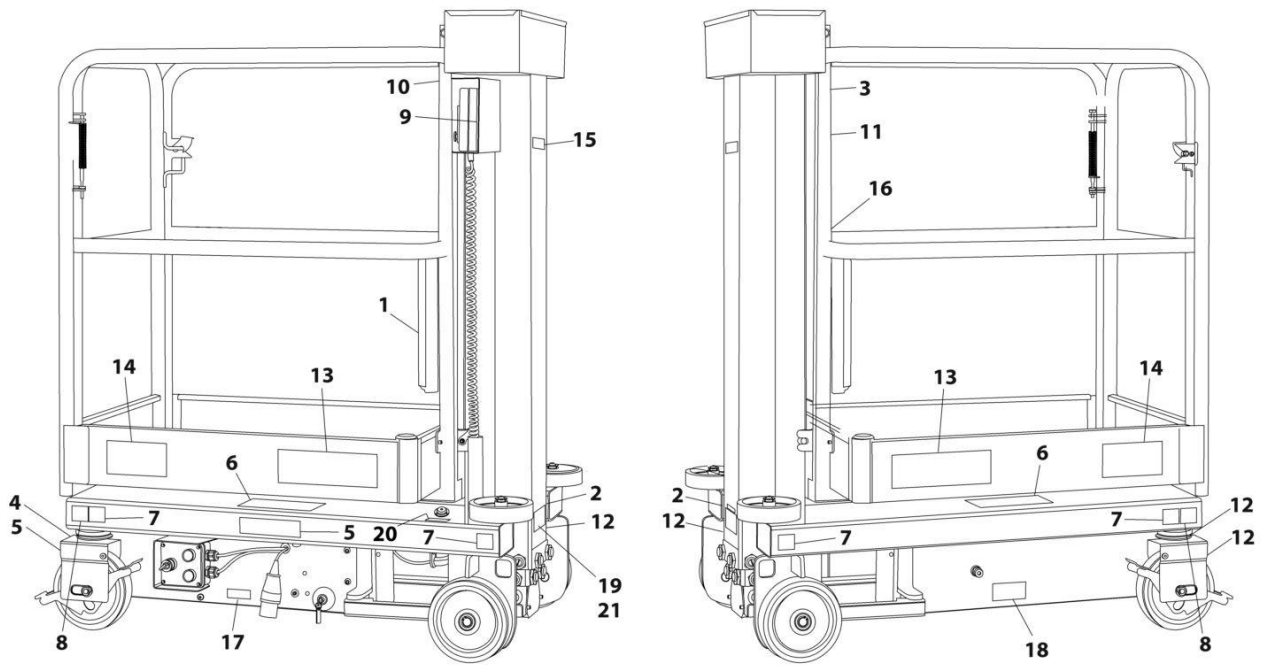

FIGURE 3-3. ELECTRICAL AND HYDRAULIC COMPONENTS

ITEM	PART NUMBER	QTY	DESCRIPTION	REV
1	PTNE202	1	'Up' Button	
2	PTNE202	1	'Down' Button	
3	PTNE204	1	Emergency Stop Button	
4	PTNH276C	1	Hydraulic Cylinder	
5	PTNH260	1	Steel Pipe Kit	
6	PTE001	1	Battery Charger	
6	1001220257	1	Battery Charger 110V	
7	PTE002AGM	1	Battery	
7	1001220252	1	Battery 12V (Standard)	
7	1001220253	1	Battery 12V (AGM)	
8	PTNE200	1	Emergency Stop / Battery Isolator	
8	PTNM341	1	Keys (Pair)	
9	PTNE205	1	Battery Cable (Set of 2)	
10	PTNH252	1	Starter Solenoid	
11	PTNE211	1	Pendant Controller c/w Cable	
12		Ref	Screw	
13	PTNH251	1	12V DC Powerpack Complete	
14	PTNH255	1	Emergency Lowering Solenoid c/w Valve	
15	PTNH256	1	Emergency Lowering Valve Cartridge (Not Shown)	

# SECTION 3 - 830P

## FIGURE 3-4. DECAL INSTALLATION (ANSI)



ART\_1001214198

FIGURE 3-4. DECAL INSTALLATION (ANSI)

ITEM	PART NUMBER	QTY	DESCRIPTION	REV
	1001214198	Ref	DECAL INSTALLATION (ANSI)	A
1	1701509	1	Decal - Manual	
2	1703817	2	Decal - Fork Lift	
3	1703781	1	Decal - Electrocution	
4	1702391	1	Decal - Hand Crushing	
5	1703813	2	Decal - Explosion	
6	1703786	2	Decal - Crushing	
7	1001213587	4	Decal - Wheel load	
8	1001213208	2	Decal - Caster Lock	
9	1001213490	1	Decal - Operator Controller	
10	1001213488	1	Decal - Capacity	
11	1001213946	1	Decal - Warning	
12	1001213442	4	Decal - Lifting/Tie Down	
13	1001213551	2	Decal - 830P	
14	1001214107	2	Decal - JLG 9.3125	
15	1001214109	1	Decal - JLG 5.125	
16	1001213582	1	Decal - Lanyard	
17	3251243	1	Decal - 120v-60Hz	
18	1001214251	1	Decal - Emergency Lowering	
19	See Note	NSS	Nameplate - Manufacture (Note: Not Available for Purchase)	
20	1703789	1	Decal - Level Indicator	
21	3820001	4	Rivet	

# SECTION 3 - 830P

## FIGURE 3-5. DECAL INSTALLATION (CSA/FRE)

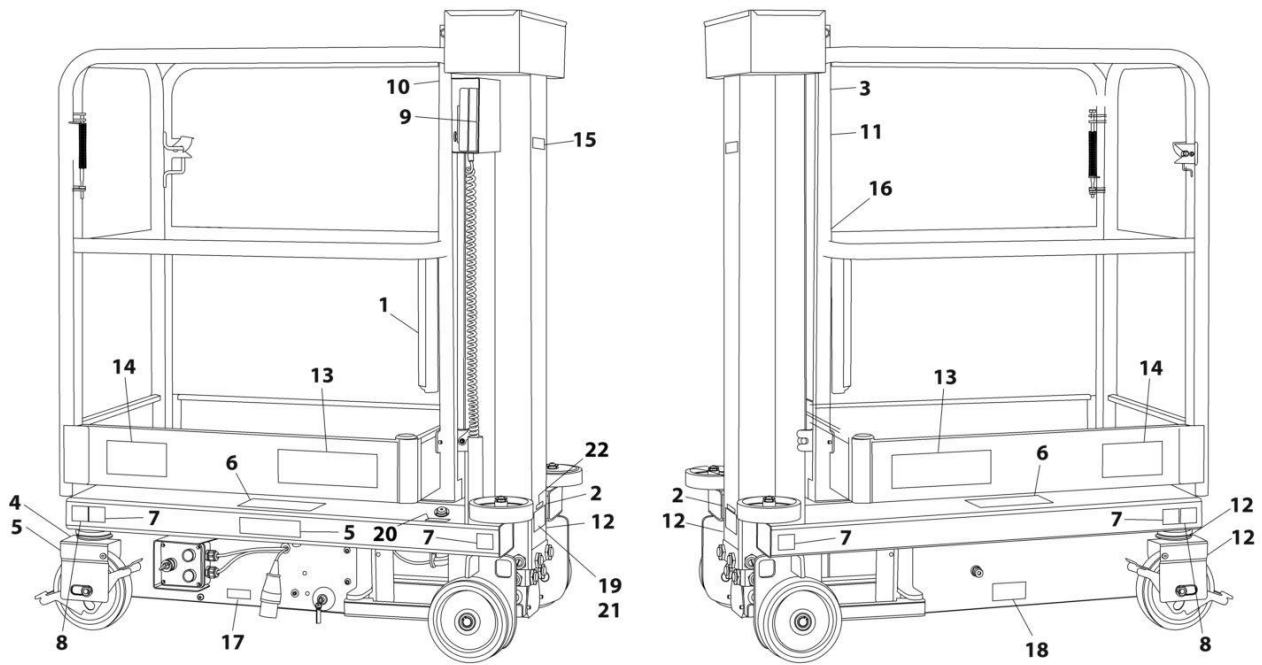

ART\_1001215008

FIGURE 3-5. DECAL INSTALLATION (CSA/FRE)

ITEM	PART NUMBER	QTY	DESCRIPTION	REV
	1001215008	Ref	DECAL INSTALLATION (CSA/FRE)	A
1	1701509	1	Decal - Manual	
2	1703817	2	Decal - Fork Lift	
3	1704795	1	Decal - Electrocuting	
4	1001215113	1	Decal - Hand Crushing	
5	1001215217	2	Decal - Explosion	
6	1704039	2	Decal - Crushing	
7	1001213587	4	Decal - Wheel Load	
8	1001213208	2	Decal - Caster Lock	
9	1001213490	1	Decal - Operator Controller	
10	1001213488	1	Decal - Capacity	
11	1001215006	1	Decal - Warning	
12	1001213442	4	Decal - Tie Down/Lift	
13	1001213551	2	Decal - Logo	
14	1001214107	2	Decal - JLG 9.3125	
15	1001214109	1	Decal - JLG 5.125	
16	1001215009	1	Decal - Lanyard	
17	3251243	1	Decal - Decal 120V-60Hz	
18	1001215004	1	Decal - Emergency Lowering	
19	See Note	NSS	Nameplate - Manufacture (Note: Not Available for Purchase)	
20	1704041	1	Decal - Level Indicator	
21	3820001	4	Rivet	
22	1706351	1	Decal - CSA	

# SECTION 3 - 830P

## FIGURE 3-6. DECAL INSTALLATION (PORTUGUESE)

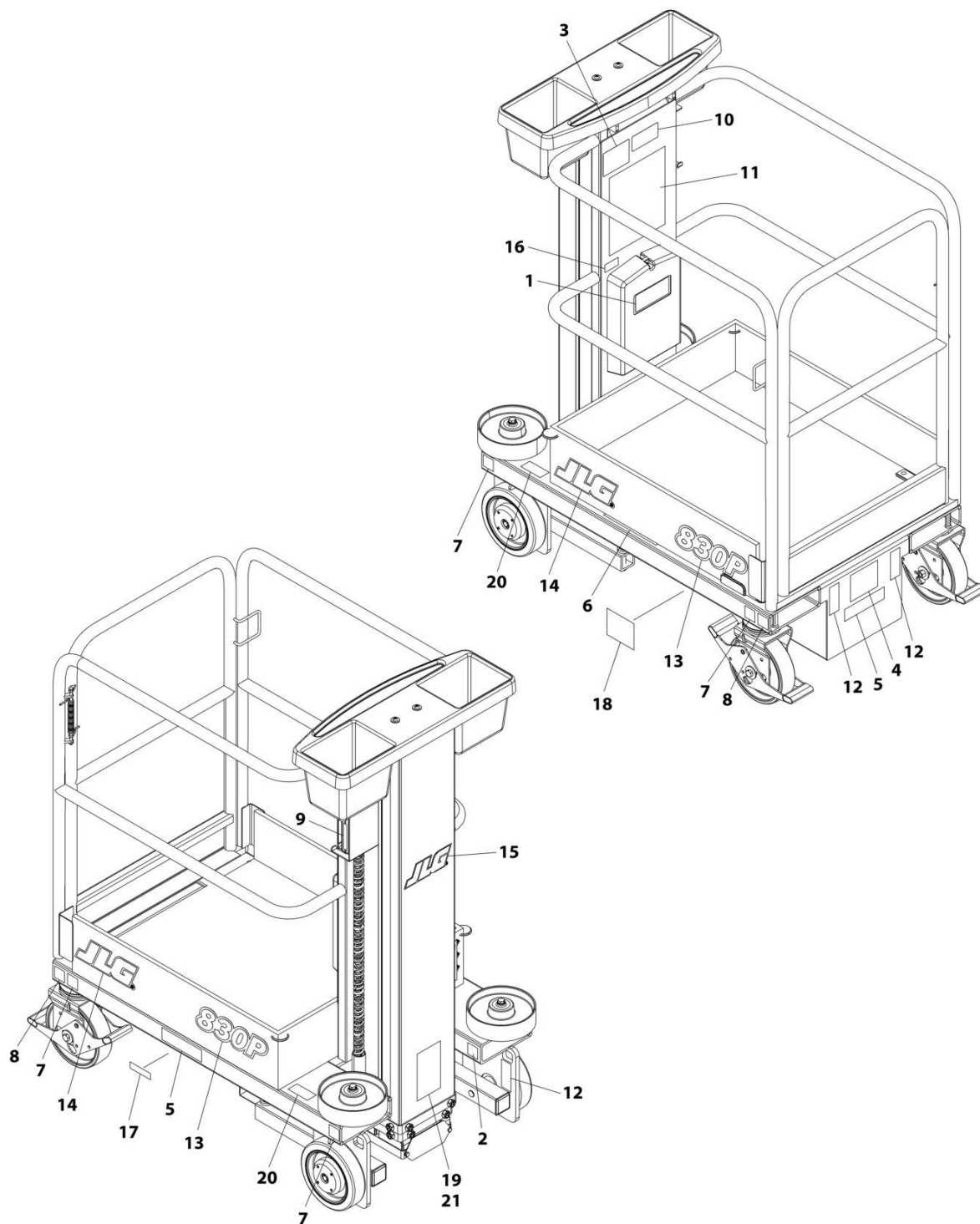

ART\_1001241789

FIGURE 3-6. DECAL INSTALLATION (PORTUGUESE)

ITEM	PART NUMBER	QTY	DESCRIPTION	REV
	1001241789	Ref	DECAL INSTALLATION (PORTUGUESE)	A
1	1701509	1	Decal - Manual	
2	1703817	2	Decal - Fork Lift	
3	1704021	1	Decal - Electrocution	
4	1001241805	1	Decal - Hand Crushing	
5	1001241806	2	Decal - Explosion	
6	1704024	2	Decal - Crushing	
7	1001213587	4	Decal - Wheel Load	
8	1001213208	2	Decal - Caster Lock	
9	1001213490	1	Decal - Operator Controller	
10	1001213488	1	Decal - Capacity	
11	1001241807	1	Decal - Warning	
12	1001213442	4	Decal - Tie Down/Lift	
13	1001213551	2	Decal - Logo	
14	1001214107	2	Decal - JLG 9.3125	
15	1001214109	1	Decal - JLG 5.125	
16	1001241802	1	Decal - Lanyard	
17	3251243	1	Decal - Decal 120V-60Hz	
18	1001241808	1	Decal - Emergency Lowering	
19	See Note	NSS	Nameplate - Manufacture (Note: Not Available for Purchase)	
20	1704026	1	Decal - Level Indicator	
21	3820001	4	Rivet	

# SECTION 3 - 830P

## FIGURE 3-7. DECAL INSTALLATION (SPANISH)

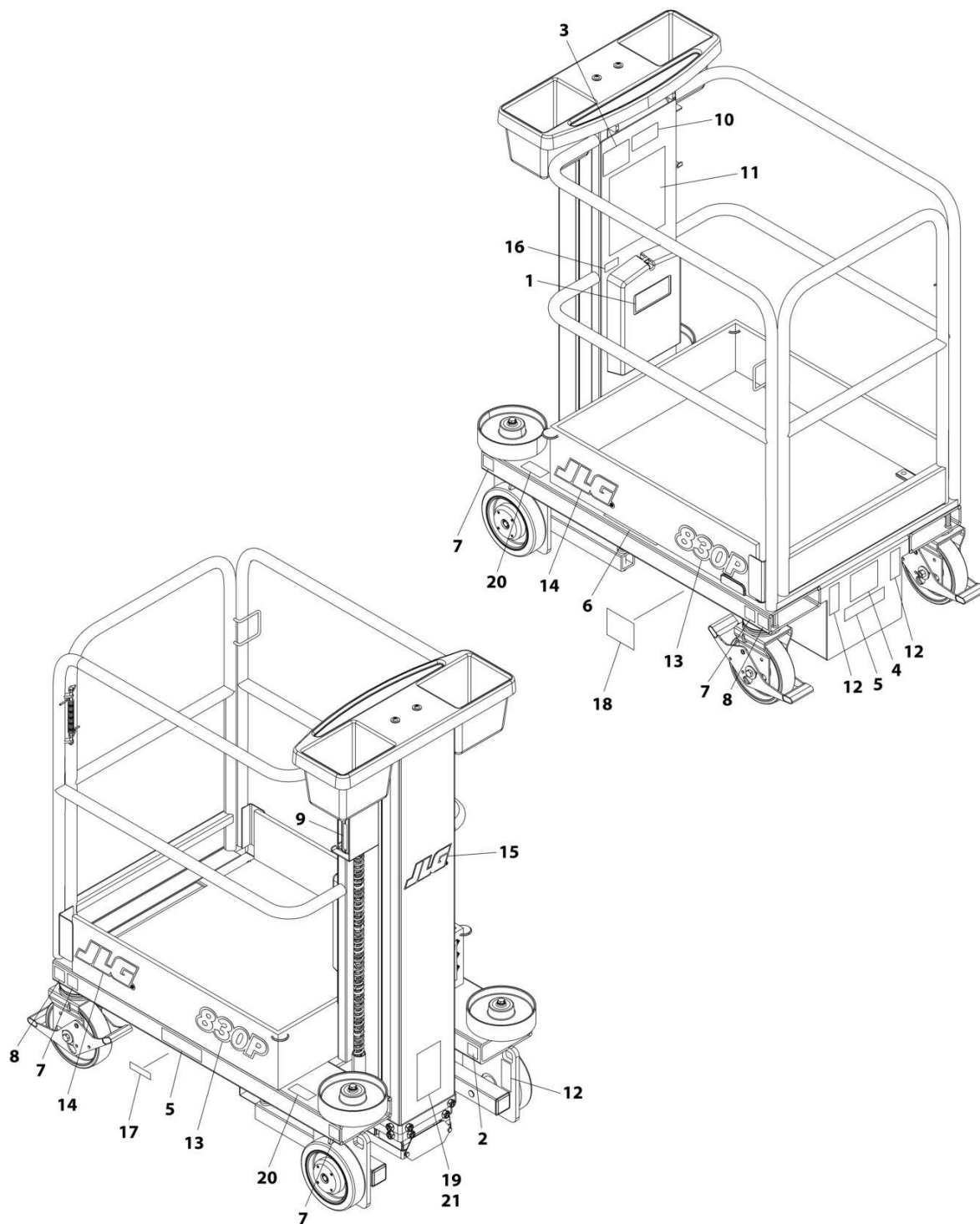

ART\_1001241788



FIGURE 3-7. DECAL INSTALLATION (SPANISH)

ITEM	PART NUMBER	QTY	DESCRIPTION	REV
	1001241788	Ref	DECAL INSTALLATION (SPANISH)	A
1	1701509	1	Decal - Manual	
2	1703817	2	Decal - Fork Lift	
3	1704029	1	Decal - Electrocutation	
4	1001241795	1	Decal - Hand Crushing	
5	1001241797	2	Decal - Explosion	
6	1704032	2	Decal - Crushing	
7	1001213587	4	Decal - Wheel Load	
8	1001213208	2	Decal - Caster Lock	
9	1001213490	1	Decal - Operator Controller	
10	1001213488	1	Decal - Capacity	
11	1001241798	1	Decal - Warning	
12	1001213442	4	Decal - Tie Down/Lift	
13	1001213551	2	Decal - Logo	
14	1001214107	2	Decal - JLG 9.3125	
15	1001214109	1	Decal - JLG 5.125	
16	1001241792	1	Decal - Lanyard	
17	3251243	1	Decal - Decal 120V-60Hz	
18	1001241799	1	Decal - Emergency Lowering	
19	See Note	NSS	Nameplate - Manufacture (Note: Not Available for Purchase)	
20	1704034	1	Decal - Level Indicator	
21	3820001	4	Rivet	

## SECTION 3 - 830P

**FIGURE 3-8. RECOMMENDED SERVICE PARTS STOCK**

ITEM	PART NUMBER	QTY	DESCRIPTION	REV
		Ref	Note: The following list will service one machine (built to current production per date on the front cover) with emergency repair parts which can be installed in the field. Parts from the list should be replaced when inventory is depleted to keep service parts stock supplied. For further information, contact your JLG dealer or the JLG Industries Parts Department.	
		Ref	STANDARD PARTS	
	PTNE211	1	Control Box c/w Cable	
	PTNE200	1	Emergency Stop/Battery Isolator	
	PTM133	1	Gate Latch c/w Fixings	
	PTNM341	1	Keys (pair)	



## SECTION 3 - 830P

### FIGURE 3-9. SPECIAL OPTIONS

ITEM	PART NUMBER	QTY	DESCRIPTION	REV
	Note	Ref	Note: This list is to accommodate machines ordered with special equipment. Options may not be applicable to all models. For more specific parts information contact JLG Parts Department	
		Ref	MISCELLANEOUS SPECIAL OPTIONS	
	1001227778	Ref	Decal Kit - Blueline	
	1001221977	Ref	Decal - Herc Rental (830P)	
	1001221998	Ref	Decal - Sunbelt Rental (830P)	

**PART NUMBER INDEX**

# PART NUMBER INDEX

1001213185.....31	1001215049 ..... 17, 33	1704795 ..... 17, 33, 53	PTE001.....49
1001213202....31, 33, 35, 37	1001215113 ..... 33, 53	1706351 ... 15, 17, 31, 33, 53	PTE002AGM .....49
1001213205....31, 33, 35, 37	1001215217 ..... 53	3251243 .... 51, 53, 55, 57	PTM1022 .....27, 43
1001213208.... 15, 17, 19, 21, 31, 33, 35, 37, 51, 53, 55, 57	1001220252 ..... 49	3820001 ... 15, 17, 19, 21, 31, 33, 35, 37, 51, 53, 55, 57	PTM103 .....43
1001213279.... 15, 17, 19, 21, 31, 33, 35, 37	1001220253 ..... 49		PTM106 ..... 12, 43
1001213367 ..... 15, 31	1001220257 ..... 49		PTM107 .....43
1001213427 ..... 15	1001221975 ..... 24		PTM126 .....43
1001213439.... 15, 17, 19, 21	1001221976 ..... 40	ECLM413 .....27	PTM133 ..... 47, 58
1001213440.... 15, 17, 19, 21	1001221977 ..... 60	ECLM600 .....27	PTNE200 .....49, 58
1001213442.... 15, 17, 19, 21, 31, 33, 35, 37, 51, 53, 55, 57	1001221996 ..... 24	ECLM601JO .....27	PTNE202 .....49
1001213488....51, 53, 55, 57	1001221997 ..... 40	ECLM602 .....27	PTNE204 .....49
1001213490....51, 53, 55, 57	1001221998 ..... 60	ECLM603 .....27	PTNE205 .....49
1001213545..... 15, 31	1001224466 ..... 24	ECLM604 .....27	PTNE211 ..... 49, 58
1001213548.... 15, 17, 19, 21	1001226127 ..... 40	ECLM605 .....27	PTNH251 .....49
1001213549....31, 33, 35, 37	1001227778 .... 24, 40, 60	ECLM606 .....27	PTNH252 .....49
1001213551 ....51, 53, 55, 57	1001241784 ..... 21	ECLM607 .....27	PTNH255 .....49
1001213582.... 15, 17, 31, 51	1001241785 ..... 37	ECLM608 .....27	PTNH256 .....49
1001213587 ....51, 53, 55, 57	1001241786 ..... 19	ECLM609 .....27	PTNH260 .....49
1001213946.....51	1001241787 ..... 35	ECLM611 .....27	PTNH276C .....49
1001213997 .... 15, 17, 31	1001241788 ..... 57	ECLM612 .....27	PTNM302 .....43
1001214107 ....51, 53, 55, 57	1001241789 ..... 55	ECLM613 .....27	PTNM303 .....47
1001214108.... 15, 17, 19, 21, 31, 33, 35, 37	1001241790 ..... 21, 37	ECLM614 .....27	PTNM305 .....47
1001214109.... 15, 17, 19, 21, 31, 33, 35, 37, 51, 53, 55, 57	1001241791 ..... 21, 37	ECLM616 .....27	PTNM320JO .....43
1001214125.... 15, 17, 19, 21, 31, 33, 35, 37	1001241792 .... 21, 37, 57	ECLM700JO .....27	PTNM321JO .....43
1001214127 ..... 12, 28	1001241793 ..... 21, 37	ECLM701 .....27	PTNM329JC .....43
1001214198 ..... 51	1001241794 ..... 21, 37	ECLM702 .....27	PTNM340 .....47
1001214251 ..... 51	1001241795 ..... 37, 57	ECLM703 ..... 27, 38	PTNM341 ..... 49, 58
1001215004 ..... 53	1001241797 ..... 57	ECLM704 .....27	PTNM342 .....44
1001215005 ..... 33	1001241798 ..... 57	ECLM705JO .....27	PTNM348JC .....43
1001215006 ..... 53	1001241799 ..... 57	ECLM706JO .....27	PTNM349JC .....43
1001215007 ..... 17, 33	1001241800 ..... 19, 35	ECLM707JC .....27	PTNM350JO .....47
1001215008 ..... 53	1001241801 ..... 19, 35	ECLM708 .....27	PTNM351JO .....47
1001215009 ..... 33, 53	1001241802 .... 19, 35, 55	ECLM709 .....27	PTNM352 .....47
1001215010 ..... 17, 33	1001241803 ..... 19, 35	ECLM710JO .....27	PTNM355 .....47
1001215011 ..... 17	1001241804 ..... 19, 35	PELM400..... 11	PTNM356 .....43
1001215012 ..... 33	1001241805 ..... 35, 55	PELM401..... 11	PTNM357 .....43
1001215043 ..... 15, 31	1001241806 ..... 55	PELM402JO ..... 11	PTNM358 .....43
	1001241807 ..... 55	PELM403..... 11	PTNM359 .....43
	1001241808 ..... 55	PELM404..... 11	PTNM360 .....43
	1701509 ... 15, 17, 19, 21, 31, 33, 35, 37, 51, 53, 55, 57	PELM405..... 11, 47	PTNM361 .....43
	1702391 ..... 31, 51	PELM406..... 11	PTNM363A .....43
	1703781 ..... 15, 31, 51	PELM407..... 11, 22	PTNM363B .....43
	1703786 ..... 15, 31, 51	PELM408..... 11	PTNM364 .....43
	1703789 ..... 15, 31, 51	PELM409..... 11	PTNM365AJC .....43
	1703813 ..... 51	PELM410JO ..... 11	PTNM365BJC .....43
	1703817 ... 15, 17, 19, 21, 31, 33, 35, 37, 51, 53, 55, 57	PELM411JO ..... 11	PTNM366 .....43
	1704021 ..... 19, 35, 55	PELM412..... 11, 27	PTNM367 .....43
	1704024 ..... 19, 35, 55	PELM413..... 11	PTNM368JO .....43
	1704026 ..... 19, 35, 55	PELM414..... 11, 27	PTNM369 .....43
	1704029 ..... 21, 37, 57	PELM415..... 11	PTNM380 .....43
	1704032 ..... 21, 37, 57	PELM416..... 11	PTNM385JO .....43
	1704034 ..... 21, 37, 57	PELM417 ..... 11	PTNM390 .....43
	1704039 ..... 17, 33, 53	PELM418..... 11	PTNM391 .....43
	1704041 ..... 17, 33, 53	PELM419JC ..... 11	PTNM392C .....43
		PELM420..... 11	PTNSPM683..... 11
		PELM421JC ..... 11, 27	
		PELM451..... 28	
		PELM800..... 11	





3121743



An Oshkosh Corporation Company

**Corporate Office**  
**JLG Industries, Inc.**  
**1 JLG Drive**  
**McConnellsburg, PA 17233-9533 USA**  
☎ **(717) 485-5161 (Corporate)**  
☎ **(877) 554-5438 (Customer Support)**  
📠 **(717) 485-6417**

**Visit our website for JLG Worldwide Locations.**  
**[www.jlg.com](http://www.jlg.com)**