



# Illustrated Parts Manual

**Models**  
**100SX**  
**110SX**  
**110SXJ**  
**120SXJ**

P/N  
3121811

*January 2, 2012*



An Oshkosh Corporation Company



# REVISION LOG

June 16, 2000 - Original Issue Of Manual

August 2, 2000 - Revised (Manual edited to 0010569 Revision 3 Models 100SX/110SX/110SXJ & 0010570 Revision 2 Model 120SXJ)

November 9, 2000 - Revised (Manual edited to 0010569 Revision 5 Models 100SX/110SX/110SXJ & 0010570 Revision 5 Model 120SXJ)

June 18, 2001 - Revised (Manual edited to 0010569 Revision 9 Models 100SX/110SX/110SXJ & 0010570 Revision 9 Model 120SXJ)

August 22, 2002 - Revised (Manual edited to 0010569 Revision 17 Models 100SX/110SX/110SXJ & 0010570 Revision 14 Model 120SXJ)

September 30, 2003 - Revised (Manual edited to 0010569 Revision 18 Models 100SX/110SX/110SXJ & 0010570 Revision 15 Model 120SXJ)

November 15, 2006 - Revised (Manual edited to 0010569 Revision 18 Models 100SX/110SX/110SXJ & 0010570 Revision 15 Model 120SXJ)

January 2, 2012 - Revised Manual

# REVISION LOG

# TABLE OF CONTENTS

FIGURE NO.	TITLE	PAGE NO.
<b>SECTION 1 - FRAME</b>		<b>1-1</b>
1-1	FRAME, VALVES AND SHIELDS INSTALLATION	1-2
1-2	VALVE ASSEMBLY - HYDRO AIR	1-6
1-3	STEERING AND AXLES INSTALLATION	1-8
1-4	TIRE AND WHEEL DRIVE INSTALLATIONS	1-12
1-5	DRIVE HUB ASSEMBLY	1-14
1-6	DRIVE MOTOR ASSEMBLY - REXROTH	1-18
1-7	JACK CYLINDER INSTALLATION	1-20
1-8	JACK VALVE ASSEMBLY - HYDRO AIR	1-22
<b>SECTION 2 - TURNTABLE</b>		<b>2-1</b>
2-1	TURNTABLE, BOOM AND SWITCHES INSTALLATION	2-2
2-2	VALVES INSTALLATION - TURNTABLE MOUNTED	2-6
2-3	VALVES ASSEMBLY - HYDRO AIR	2-10
2-4	ROTARY COUPLING AND COLLECTOR RING ASSEMBLY AND INSTALLATION	2-14
2-5	SWING DRIVE AND BEARING INSTALLATION	2-16
2-6	SWING MOTOR ASSEMBLY	2-20
2-7	SWING BRAKE ASSEMBLY	2-22
2-8	SWING HUB ASSEMBLY	2-24
2-9	LOAD MANAGEMENT INSTALLATION	2-26
2-10	GROUND CONTROLS INSTALLATION	2-28
2-11	REMOTE DRIVE CONTROL BOX ASSEMBLY	2-32
2-12	DEUTZ F4L-912 ENGINE INSTALLATION	2-34
2-13	PUMP COUPLING INSTALLATION	2-42
2-14	PUMP ASSEMBLY - SUNSTRAND	2-44
2-15	PUMP ASSEMBLY - HYDRO-AIR	2-48
2-16	TANKS INSTALLATION	2-50
2-17	HOOD INSTALLATION (PRIOR TO S/N 55762)	2-54
2-18	HOOD INSTALLATION (S/N 55762 TO PRESENT)	2-58
2-19	OIL COOLER INSTALLATION	2-62
<b>SECTION 3 - BOOM</b>		<b>3-1</b>
3-1	BOOM ASSEMBLY COMPONENTS INSTALLATION	3-2
3-2	CHAIN ADJUSTER ASSEMBLIES	3-12
3-3	JIB BOOM INSTALLATION	3-16
3-4	EXTEND-A-REACH INSTALLATION	3-18
3-5	BOOM LENGTH INDICATOR AND LIMIT SWITCHES INSTALLATION	3-22
3-6	BOOM WIPERS INSTALLATION	3-26
<b>SECTION 4 - PLATFORMS</b>		<b>4-1</b>
4-1	PLATFORM COMPONENTS INSTALLATION	4-2
4-2	PLATFORM SUPPORT & ROTATOR INSTALLATION (100SX/110SX)	4-6
4-3	PLATFORM SUPPORT & ROTATOR INSTALLATION (110SXJ/120SXJ)	4-10
4-4	ROTATOR MOTOR ASSEMBLY	4-12
4-5	PLATFORM CONSOLE ASSEMBLY	4-14
4-6	CONTROLLER ASSEMBLY (LIFT & SWING)	4-18
4-7	CONTROLLER ASSEMBLY (DRIVE & STEER)	4-20
4-8	CONTROLLER ASSEMBLY (SPEED)	4-24
4-9	SOFT TOUCH SYSTEM INSTALLATION	4-26

# TABLE OF CONTENTS

FIGURE NO.	TITLE	PAGE NO.
<b>SECTION 5 - CYLINDERS</b>		<b>5-1</b>
5-1	AXLE EXTENSION CYLINDER ASSEMBLY	5-2
5-2	PLATFORM LEVEL CYLINDER ASSEMBLY	5-4
5-3	BOOM LIFT CYLINDER ASSEMBLY	5-6
5-4	EXTEND-A-REACH LEVEL CYLINDER ASSEMBLY	5-8
5-5	EXTEND-A-REACH LIFT CYLINDER ASSEMBLY	5-10
5-6	JACK CYLINDER ASSEMBLY	5-12
5-7	MASTER CYLINDER ASSEMBLY	5-14
5-8	STEER CYLINDER ASSEMBLY	5-16
5-9	TIE ROD CYLINDER ASSEMBLY	5-18
5-10	TELESCOPE CYLINDER ASSEMBLY	5-20
<b>SECTION 6 - HYDRAULICS</b>		<b>6-1</b>
6-1	HYDRAULIC DIAGRAM - DRIVE (4WD/DEUTZ ENGINE)	6-2
6-2	HYDRAULIC DIAGRAM - T/T & BOOM	6-6
6-3	HYDRAULIC DIAGRAM - STEER	6-10
6-4	HYDRAULIC DIAGRAM - LIFTING JACKS	6-12
6-5	HYDRAULIC DIAGRAM LIST	6-14
<b>SECTION 7 - ELECTRICAL</b>		<b>7-1</b>
7-1	ELECTRICAL DIAGRAM LIST	7-2
7-2	ELECTRICAL SCHEMATIC - 100SX/110SX	7-4
7-3	ELECTRICAL SCHEMATIC - 110SXJ	7-8
7-4	ELECTRICAL SCHEMATIC - 120SXJ	7-12
7-5	HARNES COMPONENTS INSTALLATION	7-16
<b>SECTION 8 - DECALS</b>		<b>8-1</b>
8-1	DECALS INSTALLATION	8-2
<b>SECTION 9 - RECOMMENDED SERVICE PARTS STOCK</b>		<b>9-1</b>
<b>SECTION 10 - SPECIAL OPTIONS</b>		<b>10-1</b>

# SECTION 1 FRAME

<b>TABLE OF CONTENTS</b>	
<b>FIGURE</b>	<b>DESCRIPTION</b>
1-1	FRAME, VALVES AND SHIELDS INSTALLATIONS ..... 1-2
1-2	VALVE ASSEMBLY - HYDRO AIR ..... 1-6
1-3	STEERING AND AXLES INSTALLATION ..... 1-8
1-4	WHEEL DRIVE INSTALLATION ..... 1-12
1-5	DRIVE HUB ASSEMBLY ..... 1-14
1-6	DRIVE MOTOR ASSEMBLY - REXROTH ..... 1-18
1-7	JACK CYLINDER INSTALLATION ..... 1-20
1-8	JACK VALVE ASSEMBLY - HYDRO AIR ..... 1-22

# SECTION 1 FRAME

SECTION 1  
FRAME

FIGURE 1-1. FRAME, VALVES AND SHIELDS INSTALLATION

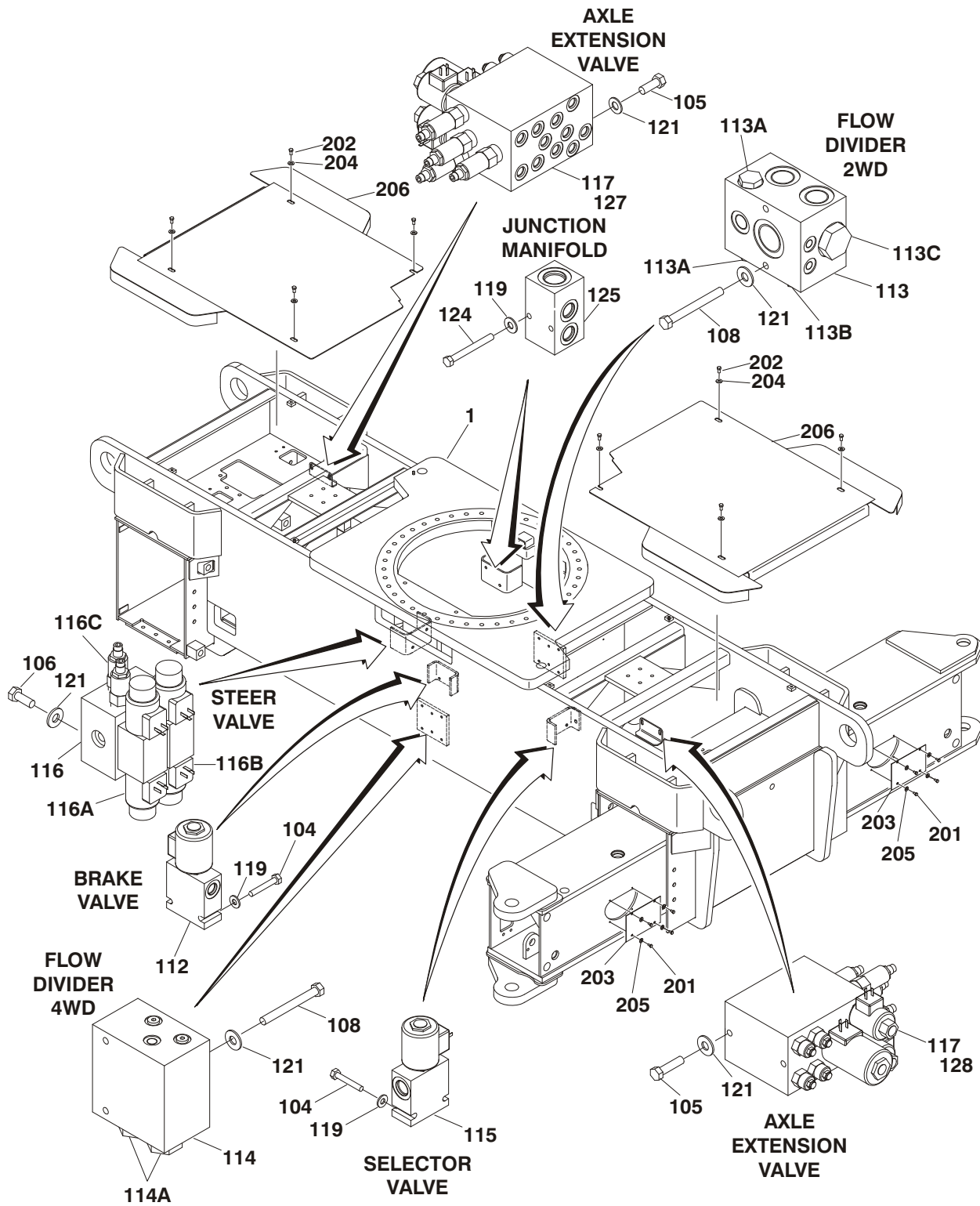



# SECTION 1 FRAME

**FIGURE 1-1. FRAME, VALVES AND SHIELDS INSTALLATION**

FIG & ITEM #	PART NUMBER	DESCRIPTION	QTY.	REV.
		<b>FRAME, VALVES AND SHIELDS INSTALLATION</b>	Ref.	
1	2360535	Frame Weldment	1	
	0270353	<b>VALVES INSTALLATION - FRAME MOUNTED (100SX/110SX)</b>	Ref.	B
	0259923	<b>VALVES INSTALLATION - FRAME MOUNTED (110SXJ/120SXJ)</b>	Ref.	E
101 to 103	Not Used			
104	0641418	Bolt 1/4"-20NC x 2 1/4"	4	
105	0641607	Bolt 3/8"-16NC x 7/8"	4	
106	0641608	Bolt 3/8"-16NC x 1"	2	
107	Not Used			
108	0641628	Bolt 3/8"-16NC x 3 1/2"	4	
109 to 111	Not Used			
112	4641154	Valve Assembly - Hydro Air Selector	1	
	7012943	Coil	1	
	7017480	Cartridge	1	
	7012973	Seal Kit - 7017480 Cartridge	1	
113	4641041	Valve Assembly - Flow Divider (2WD)	1	
113A	7022397	Cartridge, Check Valves	2	
	7022399	Seal Kit - 7022397 Cartridge	2	
113B	7022398	Cartridge, Load Shuttle	1	
	7023900	Seal Kit - 7022398 Cartridge	1	
113C	7022396	Cartridge, Flow Divider	1	
	7021625	Seal Kit - 7022396 Cartridge	1	
114	4641042	Valve Assembly - Flow Divider (4WD)	1	
114A	7012978	Cartridge	2	
	7012980	Seal Kit	2	
115	4641153	Valve Assembly - Solenoid	1	
	7012944	Coil, Solenoid		
	7012941	Cartridge		
	7010543	Seal Kit - 7012941 Cartridge		
116	4641132	Valve Assembly - Steer	1	
116A	7017490	Bosch Valve Section - Complete (Directional Control)	1	
	7021400	Spool	1	
	7021401	Coil	2	
	7021402	Seal Kit	2	
	7021403	Cap, End	2	
116B	7021407	Bosch Valve Section - Complete (Directional Control)	1	
	7021408	Spool	1	
	7021401	Coil	2	
	7021402	Seal Kit	2	
	7021403	Cap, End	2	
	7021409	Spring, Centering	2	
116C	7021644	Cartridge, Valve	2	
	7021645	Seal Kit - 7021644 Cartridge		

**SECTION 1 FRAME**

# SECTION 1 FRAME

SECTION 1 FRAME

**FIGURE 1-1. FRAME, VALVES AND SHIELDS INSTALLATION (CONTINUED)**

FIG & ITEM #	PART NUMBER	DESCRIPTION	QTY.	REV.
117	4641134	Valve Assembly - Hydro Air (See Figure 1-2 for Breakdown) (100SX & 110SX Only)	2	
118	Not Used			
119	4711400	Flatwasher 1/4" (Narrow)	7	
120	Not Used			
121	4751600	Flatwasher 3/8" (Wide)	10	
122 to 123	Not Used			
124	0641420	Bolt 1/4"-20NC x 2 1/2"	2	
125	4641155	Valve, Junction Manifold	1	
126	Not Used			
127	4641165	Valve Assembly - Hydro Air (See Figure 1-2 for Breakdown) (110SXJ & 120SXJ Only)	1	
128	4641166	Valve Assembly - Hydro Air (See Figure 1-2 for Breakdown) (110SXJ & 120SXJ Only)	1	
		<b>FRAME SHIELDS INSTALLATION OPTIONS:</b>	Ref.	
	0270200	<b>2W/D</b>	Ref.	B
	0259925	<b>4W/D</b>	Ref.	B
201	0641404	Bolt 1/4"-20NC x 1/2"	A/R	
202	0641606	Bolt 3/8"-16NC x 3/4"	8	
203	3572315	Plate, Cover	A/R	
204	4751600	Flatwasher 3/8"	8	
205	4751400	Flatwasher 1/4"	A/R	
206	4846247	Shield	2	
		-----		
	0100011	Loctite #242	A/R	

# SECTION 1 FRAME

FIGURE 1-1. FRAME, VALVES AND SHIELDS INSTALLATION (CONTINUED)

FIG & ITEM #	PART NUMBER	DESCRIPTION	QTY.	REV.

**S  
E  
C  
T  
I  
O  
N  
  
1  
  
F  
R  
A  
M  
E**

# SECTION 1 FRAME

SECTION  
1  
FRAME

FIGURE 1-2. VALVE ASSEMBLY - HYDRO AIR

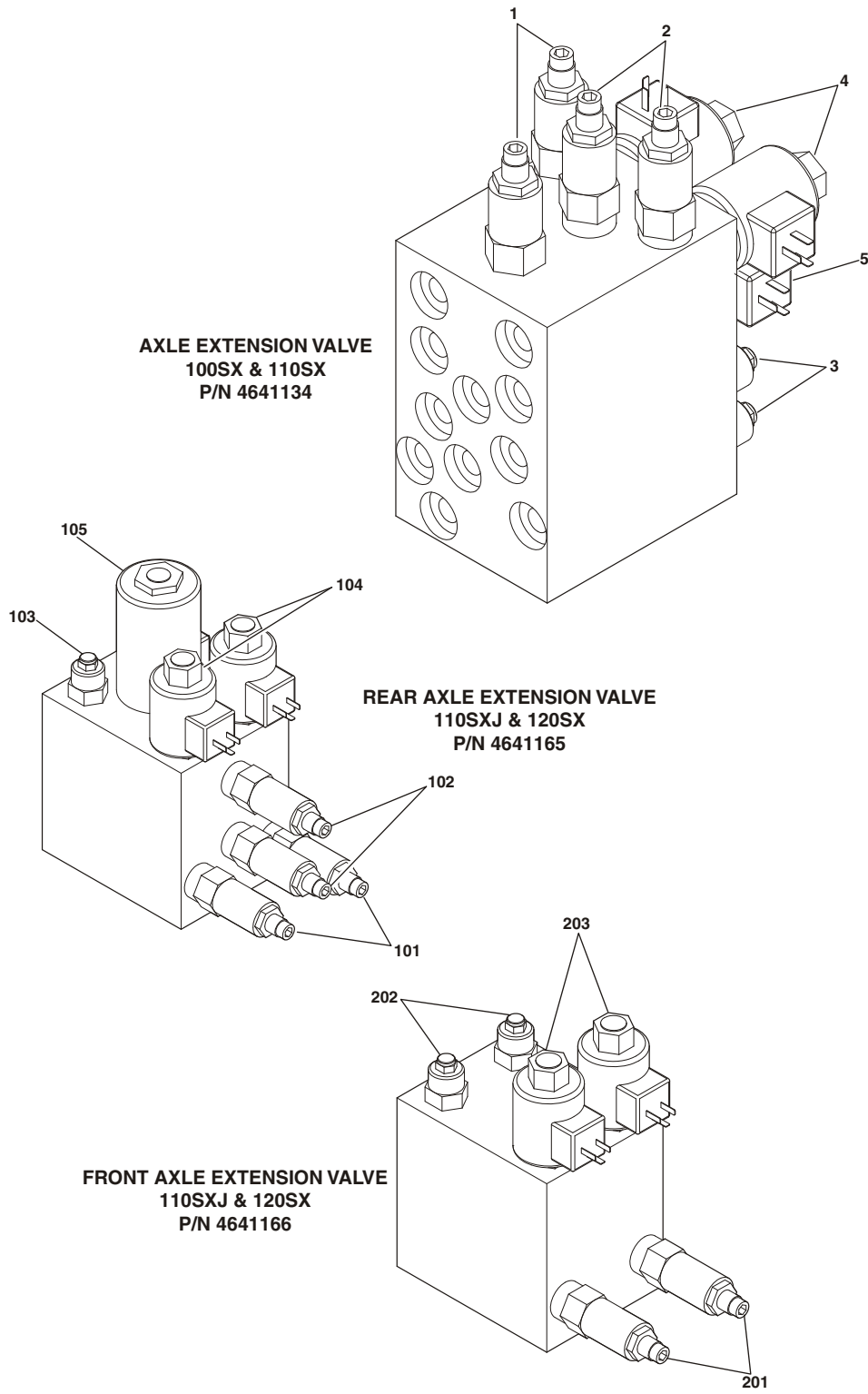

# SECTION 1 FRAME

**FIGURE 1-2. VALVE ASSEMBLY - HYDRO AIR**

FIG & ITEM #	PART NUMBER	DESCRIPTION	QTY.	REV.
	4641134	<b>AXLE EXTENSION VALVE ASSEMBLY - HYDRO AIR (100SX &amp; 110SX)</b>	Ref.	A
1	7012913	Cartridge, Valve	2	
	7017496	Seal Kit - 7012913 Cartridge (1 Per Cartridge)	2	
2	7021634	Cartridge, Valve	2	
	7021545	Seal Kit - 7021634 Cartridge (1 Per Cartridge)	2	
3	7011336	Cartridge, Check Valve	4	
4	7012995	Cartridge, Valve - Hydraforce	2	
	7012518	Seal Kit - 7012995 Cartridge (1 Per Cartridge)	2	
	7012943	Coil - 12V (1 Per Cartridge)	2	
5	7021635	Cartridge, Valve - Hydraforce	1	
	7012942	Seal Kit - 7021635 Cartridge	1	
	7012943	Coil - 12V	1	
	4641165	<b>FRONT AXLE EXTENSION VALVE ASSEMBLY - HYDRO AIR (110SXJ &amp; 120SXJ)</b>	Ref.	A
101	7012913	Cartridge, Valve	2	
	7017496	Seal Kit - 7012913 Cartridge (1 Per Cartridge)	2	
102	7021634	Cartridge, Valve	2	
	7010545	Seal Kit - 7021634 Cartridge (1 Per Cartridge)	2	
103	7011336	Cartridge, Check Valve	2	
	2900770	Seal Kit - 7011336 Cartridge (1 Per Cartridge)	2	
104	7012995	Cartridge, Valve - Hydraforce	2	
	7012518	Seal Kit - 7012995 Cartridge (1 Per Cartridge)	2	
	7012943	Coil - 12V (1 Per Cartridge)	2	
105	7021635	Cartridge, Valve - Hydraforce	1	
	7012942	Seal Kit - 7021635 Cartridge	1	
	7023994	Coil - 12V	1	
	4641166	<b>REAR AXLE EXTENSION VALVE ASSEMBLY - HYDRO AIR (110SXJ &amp; 120SXJ)</b>	Ref.	A
201	7012913	Cartridge, Valve	2	
	7017496	Seal Kit - 7012913 Cartridge (1 Per Cartridge)	2	
202	7011336	Cartridge, Check Valve	2	
	2900770	Seal Kit - 7011336 Cartridge (1 Per Cartridge)	2	
203	7012995	Cartridge, Valve - Hydraforce	2	
	7012518	Seal Kit - 7012995 Cartridge (1 Per Cartridge)	2	
	7012943	Coil - 12V (1 Per Cartridge)	2	

**SECTION 1 FRAME**

# SECTION 1 FRAME

FIGURE 1-3. STEERING AND AXLES INSTALLATION

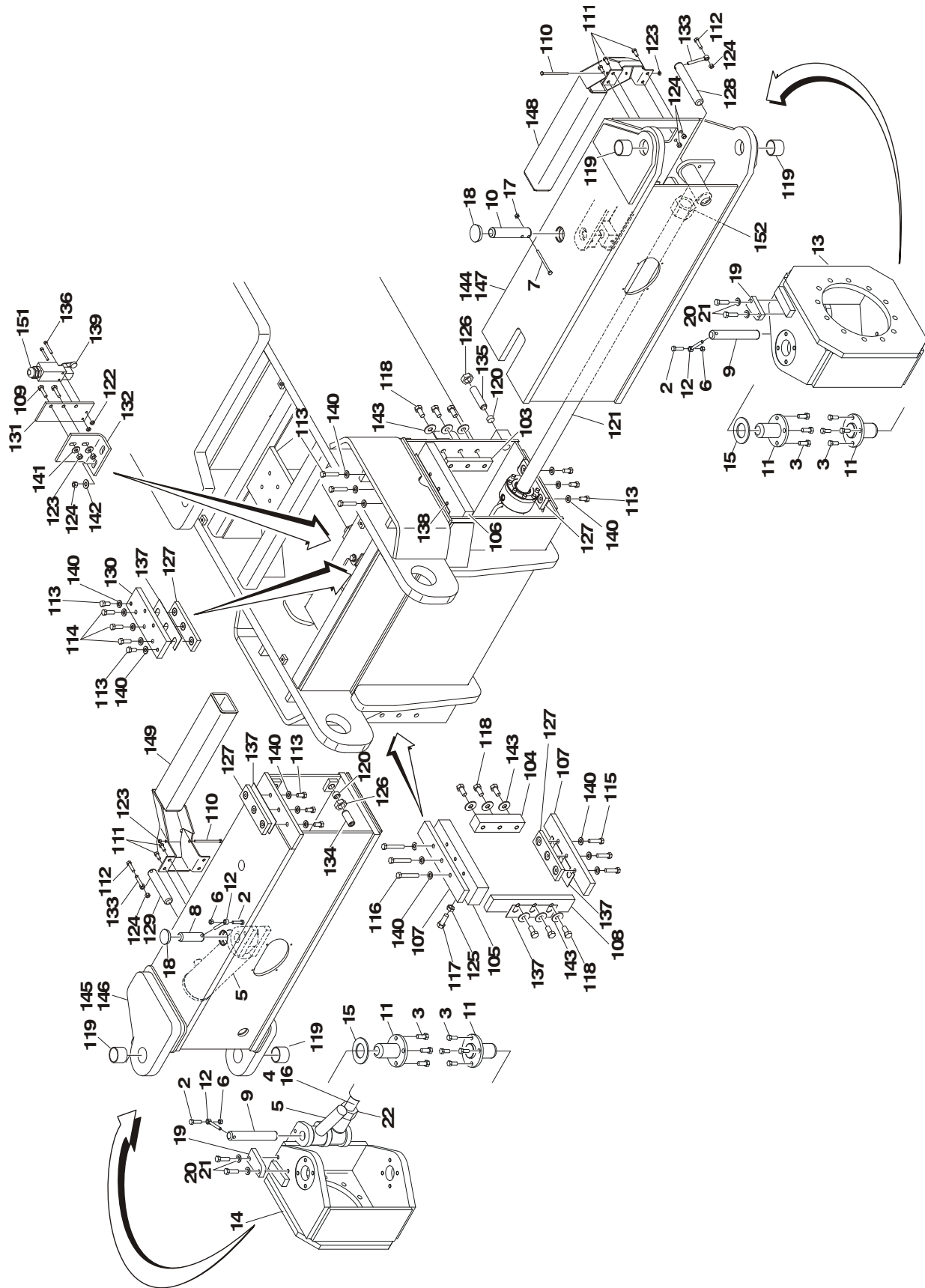

# SECTION 1 FRAME

**FIGURE 1-3. STEERING AND AXLES INSTALLATION**

FIG & ITEM #	PART NUMBER	DESCRIPTION	QTY.	REV.
		<b>STEERING INSTALLATIONS</b>	Ref.	
	0259920	<b>2WS</b>	Ref.	D
	0259919	<b>4WS</b>	Ref.	F
1	Not Used			
2	0641612	Bolt 3/8"-16NC x 1 1/2"	3	
3	0641810	Bolt 1/2"-13NC x 1 1/4"	16	
4	1683921	Cylinder, Tie-Rod (See Section 5 for Breakdown)	1	
5		Steer Cylinder Assembly Options (See Section 5 for Breakdown):	2	
	1683935	Steer Cylinder Assembly (2WS)		
	1683958	Steer Cylinder Assembly (4WS)		
6	3311605	Locknut 3/8"-16NC	3	
7	0641430	Bolt 1/4"-20NC x 3 3/4"	1	
8	3422688	Pin (Steer Cylinder)	1	
9	3422764	Pin (Steer Cylinder)	2	
10	3422856	Pin, Weldment (Steer Cylinder)	1	
11	Use 3422972	Kingpin (was p/n 3422849)	4	
12	3841143	Keeper 3/8"	3	
13	4130374	Spindle Weldment (LF, RR)	A/R	
14	4130375	Spindle Weldment (RF, LR)	A/R	
15		Washer, Thrust Options:	2	
	Use 4740517	Prior to S/N 67242 (was p/n 4740314 & 4740463)		
	4740517	S/N 67242 to Present		
16	4846204	Weldment, Tie-Rod	1	
17	3311405	Locknut 1/4"-20NC	1	
18	3520181	Plug	2	
19		Stop Options:	2	
	0561404	(2WS)		
	0561403	(4WS)		
20	0641814	Bolt 1/2"-13NC x 1 3/4"	4	
21	4711800	Flatwasher 1/2" (Narrow)	4	
22	3313002	Nut, Jam 1 1/4"-7NC	1	
		-----		
	0100011	Loctite #242	A/R	
		<b>EXTENDABLE AXLES INSTALLATION</b>	Ref.	
	0259922	<b>4WD/2WS</b>	Ref.	B
	0259921	<b>4WD/4WS</b>	Ref.	C
101	Not Used			
102	Not Used			
103	0561391	Block, Axle Stop (Side)	2	
104	0561392	Block, Axle Stop (Side)	2	
105	0561394	Block, Axle Stop (Top)	2	
106	0561400	Block, Axle Stop (Top)	2	
107	0561401	Block, Axle Stop (Bottom)	4	
108	0561402	Plate, Spacer	2	
109	0641408	Bolt 1/4"-20NC x 1"	8	

**SECTION 1 FRAME**

# SECTION 1 FRAME

## SECTION 1 FRAME

**FIGURE 1-3. STEERING AND AXLES INSTALLATION (CONTINUED)**

FIG & ITEM #	PART NUMBER	DESCRIPTION	QTY.	REV.
110	0641436	Bolt 1/4"-20NC x 4 1/2"	4	
111	0641607	Bolt 3/8"-16NC x 7/8"	16	
112	0641612	Bolt 3/8"-16NC x 1 1/2"	4	
113	0641808	Bolt 1/2"-13NC x 1"	26	
114	0641812	Bolt 1/2"-13NC x 1 1/2"	6	
115	0641816	Bolt 1/2"-13NC x 2"	6	
116	0641820	Bolt 1/2"-13NC x 2 1/2"	6	
117	0642014	Bolt 5/8"-11NC x 1 3/4"	4	
118	0642010	Bolt 5/8"-11NC x 1 1/4"	18	
119	0961950	Bearing	4	
120	1120465	Cap	16	
121	1683920	Axle Extension Cylinder Assembly (See Section 5 for Breakdown)	2	
122	3310805	Locknut #8-32NC	8	
123	3311405	Locknut 1/4"-20NC	12	
124	3311605	Locknut 3/8"-16NC	28	
125	3312002	Nut, Jam 5/8"-11NC	4	
126	3312602	Nut, Jam 1"-8NC	16	
127	3340888	Wear, Pad Assembly	8	
128	3422689	Pin	2	
129	3422818	Pin	2	
130	3572340	Plate	2	
131	3572346	Plate, Switch Mount	4	
132	3572347	Angle, Switch Mount	4	
133	3841143	Keeper, 3/8"	4	
134	3900219	Set Screw	4	
135	3900292	Set Screw	12	
136	3930820	Bolt #8-32NC x 1 1/4"	8	
137	4070772	Shim	12	
138	4071001	Shim, Axle Stop	7	
139	4360322	Switch, Limit	4	
140	4711800	Flatwasher 1/2" (Narrow)	38	
141	4751400	Flatwasher 1/4" (Wide)	8	
142	4751600	Flatwasher 3/8" (Wide)	8	
143	4752000	Flatwasher 5/8" (Wide)	18	
144	4846176	Outer Axle Weldment	A/R	
145	4846177	Inner Axle Weldment	A/R	
146	4846219	Inner Axle Weldment (110SX/110SXJ 4WD/2WS Rear Only)	1	
147	4846220	Outer Axle Weldment (110SX/110SXJ 4WD/2WS Rear Only)	1	
148	4846226	Hose Carrier Weldment (LF, RR)	2	
149	4846227	Hose Carrier Weldment (RF, LR)	2	
150	Not Used			
151	4460428	Connector, Strain Relief (110SX/110SXJ 4WD/2WS Only)	4	
152	3951804	Set Screw, Knurled Cup Point 1/2" x 1/2"		
	0100011	Loctite #242	A/R	
	0100079	Sealant, Pipe	A/R	



# SECTION 1 FRAME

FIGURE 1-3. STEERING AND AXLES INSTALLATION (CONTINUED)

FIG & ITEM #	PART NUMBER	DESCRIPTION	QTY.	REV.

**S  
E  
C  
T  
I  
O  
N  
  
1  
  
F  
R  
A  
M  
E**

# SECTION 1 FRAME

FIGURE 1-4. TIRE AND WHEEL DRIVE INSTALLATIONS

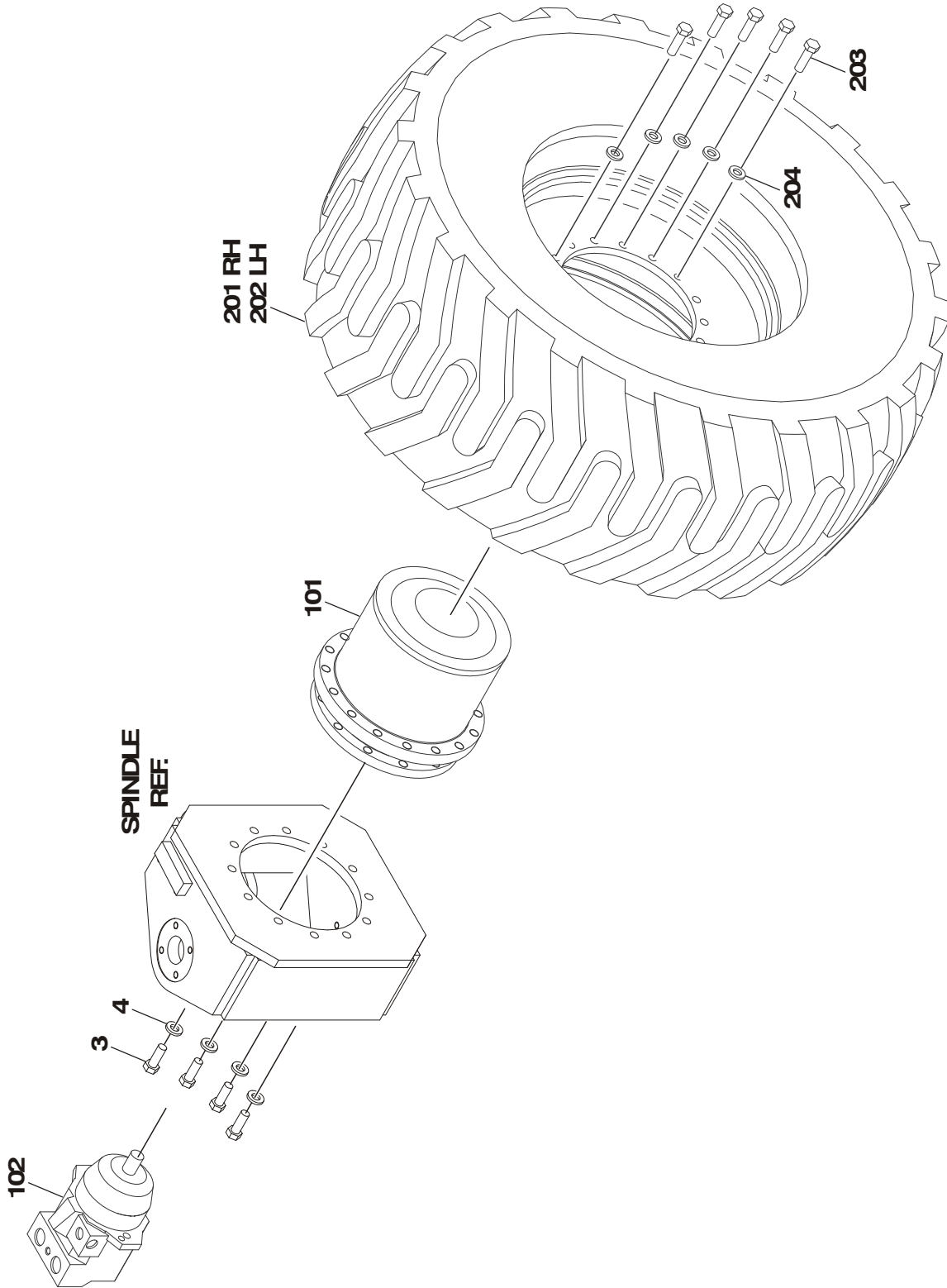

# SECTION 1 FRAME

**FIGURE 1-4. TIRE AND WHEEL DRIVE INSTALLATIONS**

FIG & ITEM #	PART NUMBER	DESCRIPTION	QTY.	REV.
		<b>TIRE AND WHEEL DRIVE INSTALLATIONS</b>	Ref.	
	0259895	<b>WHEEL DRIVE INSTALLATION</b>	Ref.	B
1	Not Used			
2	Not Used			
3	0701617	Bolt (Metric)16mm x 45mm (12 Per Wheel)	48	
4	4892000	Washer Hardened 5/8" (12 Per Wheel)	48	
	0100019	Loctite #271	A/R	
	0259878	<b>HUB AND MOTOR ASSEMBLY</b>	Ref.	C
101	2780248	Drive Hub Assembly (See Figure 1-5 for Breakdown)	4	
102	3160248	Drive Motor Assembly (See Figure 1-6 for Breakdown)	4	
		<b>TIRE AND WHEEL INSTALLATIONS (FOAM-FILLED)</b>	Ref.	
	0259909	<b>100SX/110SX &amp; 110SXJ</b>	Ref.	A
	0259906	<b>120SXJ</b>	Ref.	A
201		Tire and Wheel Assembly (Foam-Filled) Options: Right Side (100SX/110SX & 110SXJ)	2	
	0259907	Right Side (120SXJ)		
202		Tire and Wheel Assembly (Foam-Filled) Options: Left Side (100SX/110SX & 110SXJ)	2	
	0259908	Left Side (120SXJ)		
	0259905	Left Side (120SXJ)		
	4520215	Tire 385/65 x 22.5		
	4640113	Valve		
		<b>Note: Assemblies may require ballast/foam filling to manufacturer's specifications prior to installing on a machine. Refer to Operation &amp; Safety or Service &amp; Maintenance Manuals. Purchase individual tire and/or rim only if able to foam fill tire &amp; wheel assembly, otherwise, purchase complete assembly.</b>		
203	0701619	Bolt (Metric)16mm x 55mm (16 Per Wheel)	64	
204	4892000	Washer Hardened 5/8" (16 Per Wheel)	64	

# SECTION 1 FRAME

## SECTION 1 FRAME

FIGURE 1-5. DRIVE HUB ASSEMBLY

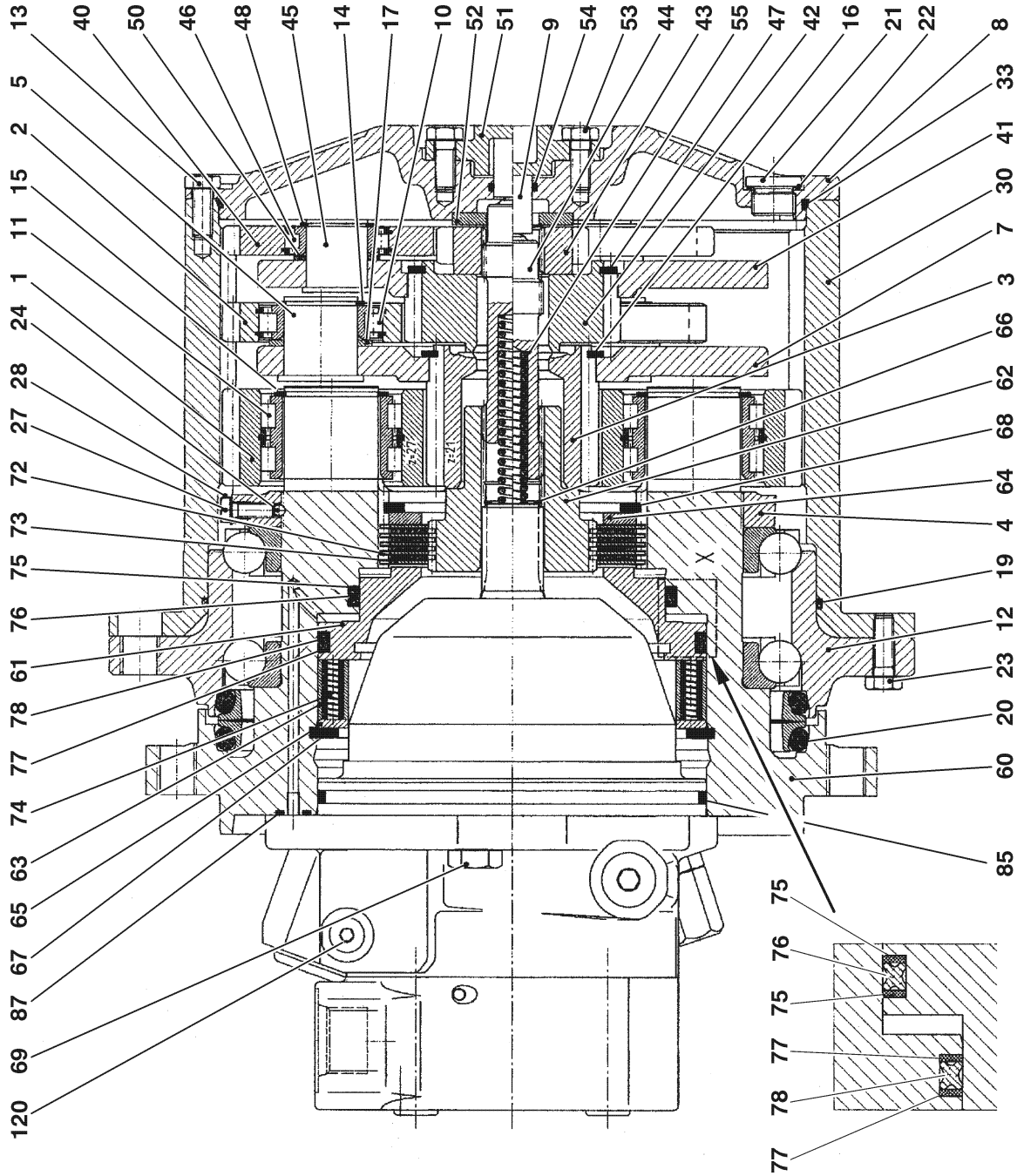

# SECTION 1 FRAME

**FIGURE 1-5. DRIVE HUB ASSEMBLY**

FIG & ITEM #	PART NUMBER	DESCRIPTION	QTY.	REV.
	2780248	<b>DRIVE HUB ASSEMBLY</b> <b>Note: Unless there is capability to torque shaft (item 4) to 626 ft./lbs. (850Nm) Repair beyond this level is NOT advised.</b>	Ref. Ref.	C
1	Kit 1	Gear, Planet	1	
2	Kit 2	Gear, Planet	1	
3	7022535	Gear, Sun	1	
4	Kit 3	Nut, Shaft	1	
5	7021388	Pin, Planet	3	
6	Not Used			
7	7022537	Carrier, Planet	1	
8	7022538	Cover	1	
9	7024967	Button, Thrust	1	
10	Kit 2	Bearing, Roller	3	
11	7022541	Bearing, Roller	4	
12	Kit 3	Bearing, Ball	1	
13	7022543	Bolt, Hex	12	
14	Kit 2	Ring, Retaining	3	
15	Kit 1	Ring, Retaining	4	
16	7022546	Ring, Retaining	1	
17	Kit 2	Ring, Stay	3	
18	Not Used			
19	7024966	O-Ring	1	
20	7024968	Seal, Face	1	
21	7022550	Plug	2	
22	Kit 4	Seal, Ring	2	
23	Kit 3	Bolt	2	
24	Not Available	Ball	2	
25 to 26	Not Used			
27	Not Available	Bolt	2	
28	7025555	Washer	2	
29	Not Used			
30	7022556	Gear, Ring	1	
31 to 32	Not Used			
33	Kit 4	O-Ring	1	
34 to 40	Not Used			
41	7022559	Carrier		
42	7022560			
43	Kit 4	Gear, Sun	1	
44	Kit 4	Shaft, Input	1	
45	7011326	Pin, Planet	3	
46	Not Used			
47	7022564	Ring, Retaining	1	
48 to 50	Not Used			
51	7022567	Cover	1	
52	7022568	Washer Thrust	1	
53	Kit 3	Bolt	2	
54	Kit 4	O-Ring	1	

**SECTION 1 FRAME**

# SECTION 1 FRAME

**SECTION 1 FRAME**

**FIGURE 1-5. DRIVE HUB ASSEMBLY (CONTINUED)**

FIG & ITEM #	PART NUMBER	DESCRIPTION	QTY.	REV.
55	Kit 4	Spring, Pressure	1	
56 to 59	Not Used			
60	7022572	Spindle	1	
61	7022573	Piston	1	
62	7022574	Coupler	1	
63	7022575	Ring, Locator	1	
64	7021354	Plate, Back-up	1	
65	7022576	Plate, Back-up	1	
66	7022577	Ring, Retaining	1	
67	7022578	Ring, Retaining	1	
68	7022509	Ring, Retaining	1	
69	7022579	Bolt	2	
70 to 71	Not Used			
72	Kit 5	Disc, Brake	4	
73	Kit 5	Disc, Brake	5	
74	Kit 5	Spring	A/R	
75	Kit 6	Ring, Back-up	2	
76	Kit 6	Seal	1	
77	Kit 6	Ring, Back-up	2	
78	Kit 6	Seal	1	
79 to 84	Not Used			
85	7024031	O-Ring	1	
86	Not Used			
87	7024032	O-Ring	1	
88 to 119	Not Used			
120	3160248	Motor, Hydraulic	1	
	7024028	Kit 1 - Planet Bearing Kit (Includes Items 1, 11 & 15)	1	
	7024029	Kit 2 - Planet Bearing Kit (Includes Items 2, 10, 14 & 17)	1	
	7022536	Kit 3 - Bearing Kit (Includes Items 4, 12, 23, & 53)	1	
	7022540	Kit 4 - Mechanical Disconnect Kit (Includes Items 13, 22, 33, 43, 44, 54 & 55)	1	
	7022580	Kit 5 - Brake Disc Kit (Includes Items 72-74)	1	
	7022581	Kit 6 - Brake Seal Kit (Includes Items 75-78)	1	
	7024030	Kit 7 - Planet Gear Kit (Includes Items 40, 46, 48 & 50)	1	

# SECTION 1 FRAME

FIGURE 1-5. DRIVE HUB ASSEMBLY (CONTINUED)

FIG & ITEM #	PART NUMBER	DESCRIPTION	QTY.	REV.

**S  
E  
C  
T  
I  
O  
N  
  
1  
  
F  
R  
A  
M  
E**

# SECTION 1 FRAME

SECTION 1 FRAME

FIGURE 1-6. DRIVE MOTOR ASSEMBLY - REXROTH

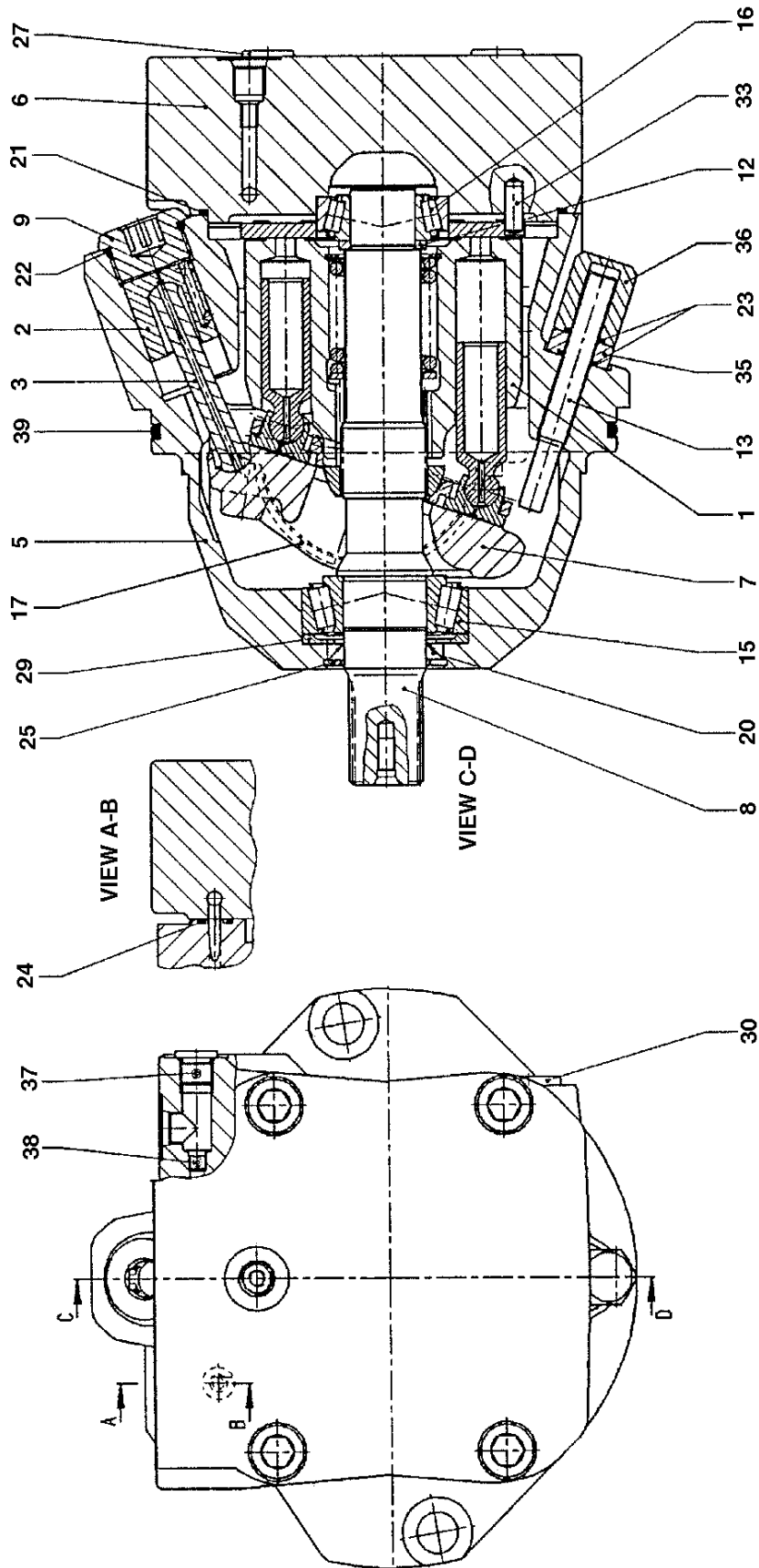



# SECTION 1 FRAME

**FIGURE 1-6. DRIVE MOTOR ASSEMBLY - REXROTH**

FIG & ITEM #	PART NUMBER	DESCRIPTION	QTY.	REV.
	3160248	<b>DRIVE MOTOR ASSEMBLY</b>	Ref.	D
1	7012716	Rotary Group Assembly	1	
2	Not Available	Piston, Control	1	
3	Not Available	Rod, Piston	1	
4	Not Used			
5	Not Available	Housing	1	
6	Not Available	Plate, Port	1	
7	7024036	Plate, Swash	1	
8	7024037	Driveshaft	1	
9	Not Available	Plug, Screw	1	
10 to 11	Not Used			
12	7012709	Shim	1	
13	Not Available	Stop Screw	1	
14	Not Used			
15	7024038	Bearing	1	
16	7012706	Bearing	1	
17	7024039	Shell, Cradle	2	
18 to 19	Not Used			
20	Kit	Seal, Shaft	1	
21	Kit	O-Ring	1	
22	Kit	O-Ring	1	
23	Kit	O-Ring	2	
24	Kit	Seal	1	
25	7012715	V-Ring	1	
26	Not Used			
27	7024040	Screw, Socket head M12 x 60	4	
28	Not Used			
29	Not Available	Ring, Stop	1	
30	Not Available	Plug	1	
31 to 32	Not Used			
33	Not Available	Pin, Dowel	1	
34	Not Used			
35	Not Available	Nut M10	1	
36	Not Available	Nut, Cap M10	1	
37	Kit	Plug	1	
38	7024041	Orifice	1	
39	Kit	O-Ring	1	
	7024034	Seal Kit (Includes Items 20-24, 37 & 39)	1	

**SECTION 1 FRAME**

# SECTION 1 FRAME

SECTION 1 FRAME

FIGURE 1-7. JACK CYLINDER INSTALLATION

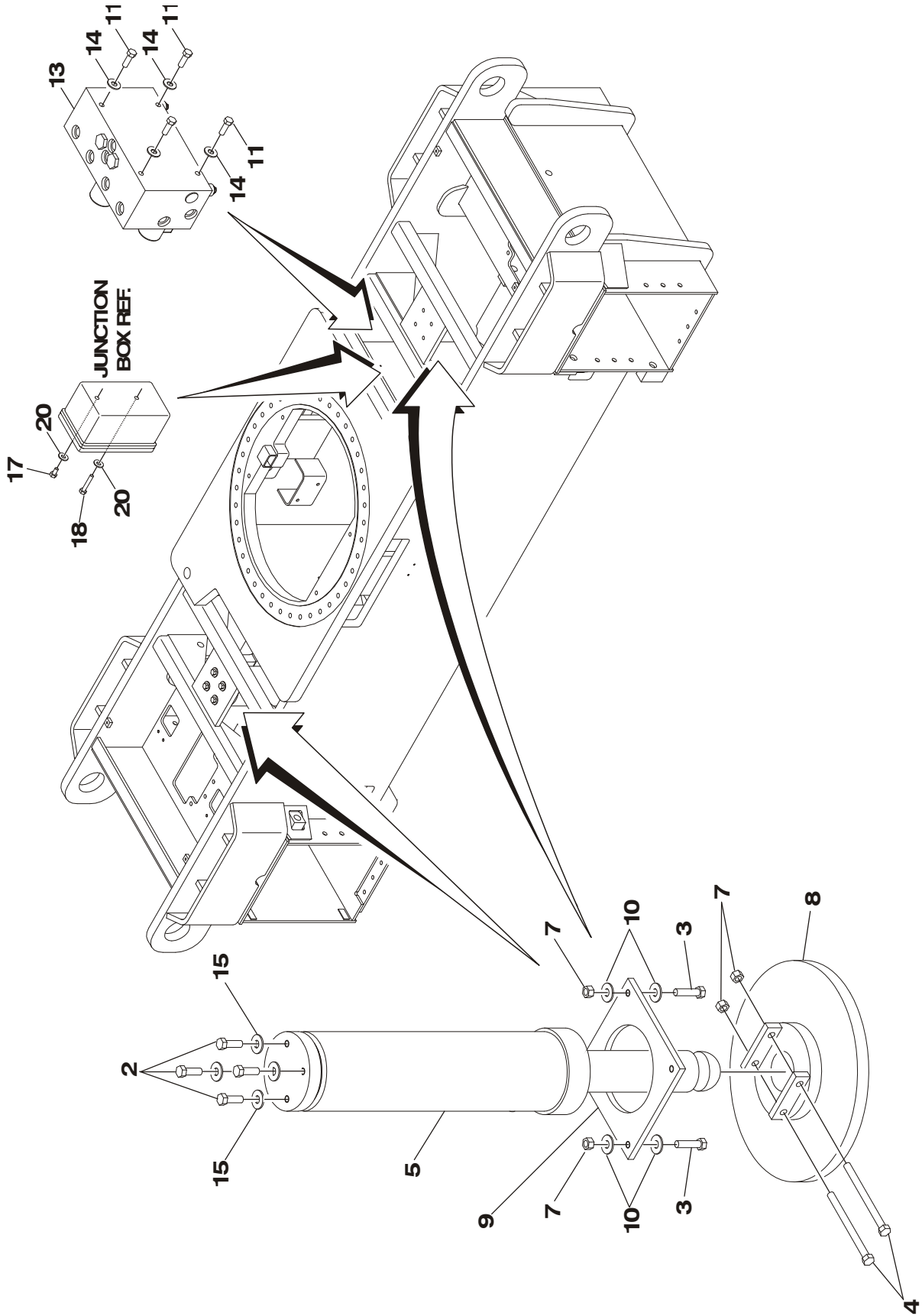

# SECTION 1 FRAME

**FIGURE 1-7. JACK CYLINDER INSTALLATION**

FIG & ITEM #	PART NUMBER	DESCRIPTION	QTY.	REV.
	0270268	<b>JACK CYLINDER INSTALLATION</b>	Ref.	C
1	Not Used			
2	0641812	Bolt 1/2"-13NC X 1 1/2" (4 Per Cylinder)	8	
3	0641816	Bolt 1/2"-13NC x 2" (4 Per Cylinder)	8	
4	0641852	Bolt 1/2" -13 NC x 6 1/2"	4	
5	1683965	Jack Cylinder Assembly (See Section 5 for Breakdown)	2	
6	Not Used			
7	3311805	Locknut 1/2"-13NC (4 Per Cylinder)	12	
8	3340630	Jack Pad Weldment	2	
9	3535906	Plate, Mounting (1 Per Cylinder)	2	
10	4711800	Flatwasher 1/2" Narrow (4 Per Cylinder)	8	
11	0641609	Bolt 3/8"-16NC X 1 1/8"	4	
12	1704544	Decal- Lifting Instructions (Not Shown)	1	
13	4641133	Valve, Jack (See Figure 1-8 For Breakdown)	1	
14	4751600	Flatwasher 3/8" (Wide)	4	
15	4751800	Flatwasher 1/2" (Wide)	8	
16	Not Used			
17	0641404	Bolt 1/4"-20NC X 1/2"	1	
18	0641412	Bolt 1/4"-20NC X 1 1/2"	1	
19	Not Used			
20	4751400	Flatwasher 1/4" (Wide)	2	
	0100011	----- Loctite	A/R	

**SECTION 1 FRAME**

# SECTION 1 FRAME

SECTION  
1  
FRAME

FIGURE 1-8. JACK VALVE ASSEMBLY - HYDRO AIR

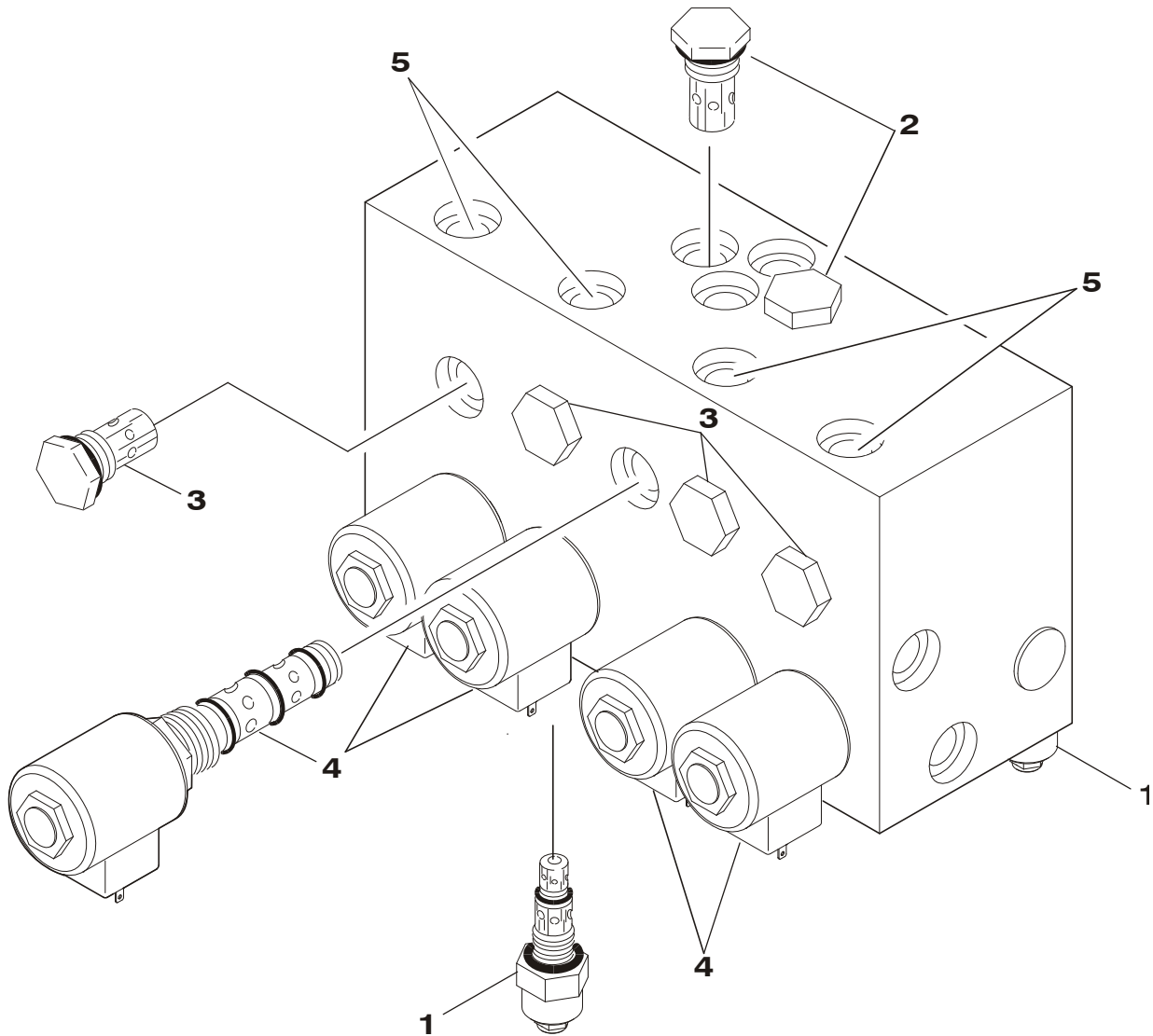

# SECTION 1 FRAME

**FIGURE 1-8. JACK VALVE ASSEMBLY - HYDRO AIR**

FIG & ITEM #	PART NUMBER	DESCRIPTION	QTY.	REV.
	4641133	<b>VALVE ASSEMBLY - HYDRO AIR</b>	Ref.	A
1	7011336	Cartridge, Check Valve	2	
2	7012955	Cartridge, Valve	2	
	7012967	Seal Kit - 7012955 Cartridge (1 Per Cartridge)	2	
3	7021631	Cartridge, Valve	4	
	7021632	Seal Kit - 7021631 Cartridge (1 Per Cartridge)	4	
4	7012995	Cartridge, Valve - Hydraforce	5	
	7012518	Seal Kit - 7012995 Cartridge (1 Per Cartridge)	5	
	7012943	Coil - 12V (1 Per Cartridge)	5	
5	7021633	Orifice	4	

**SECTION 1 FRAME**

# SECTION 1 FRAME

**S  
E  
C  
T  
I  
O  
N  
  
1  
  
F  
R  
A  
M  
E**

**FIGURE 1-8. JACK VALVE ASSEMBLY - HYDRO AIR (CONTINUED)**

FIG & ITEM #	PART NUMBER	DESCRIPTION	QTY.	REV.

# SECTION 2 TURNTABLE

## TABLE OF CONTENTS

FIGURE	DESCRIPTION	PAGE
2-1	TURNTABLE, BOOM AND SWITCHES INSTALLATION . . . . .	2-2
2-2	VALVES INSTALLATION - TURNTABLE MOUNTED . . . . .	2-6
2-3	VALVE ASSEMBLY - HYDRO-AIR . . . . .	2-10
2-4	ROTARY COUPLING AND COLLECTOR RING ASSEMBLY AND INSTALLATION . . . . .	2-14
2-5	SWING DRIVE AND BEARING INSTALLATIONS . . . . .	2-16
2-6	SWING MOTOR ASSEMBLY . . . . .	2-20
2-7	SWING BRAKE ASSEMBLY . . . . .	2-22
2-8	SWING HUB ASSEMBLY . . . . .	2-24
2-9	LOAD MANAGEMENT INSTALLATION . . . . .	2-26
2-10	GROUND CONTROLS INSTALLATION . . . . .	2-28
2-11	REMOTE DRIVE CONTROL BOX ASSEMBLY . . . . .	2-32
2-12	DEUTZ F4L-912 ENGINE INSTALLATION . . . . .	2-34
2-13	PUMP COUPLING INSTALLATION . . . . .	2-42
2-14	PUMP ASSEMBLY - SUNSTRAND . . . . .	2-44
2-15	PUMP ASSEMBLY - HYDRO-AIR . . . . .	2-48
2-16	TANKS INSTALLATION . . . . .	2-50
2-17	HOODS AND ALARM INSTALLATION (PRIOR TO S/N 55762) . . . . .	2-54
2-18	HOODS AND ALARM INSTALLATION (S/N 55762 TO PRESENT) . . . . .	2-58
2-19	OIL COOLER INSTALLATION . . . . .	2-62

SECTION 2 TURNTABLE

# SECTION 2 TURNTABLE

FIGURE 2-1. TURNTABLE, BOOM AND SWITCHES INSTALLATION

SECTION 2 TURNTABLE

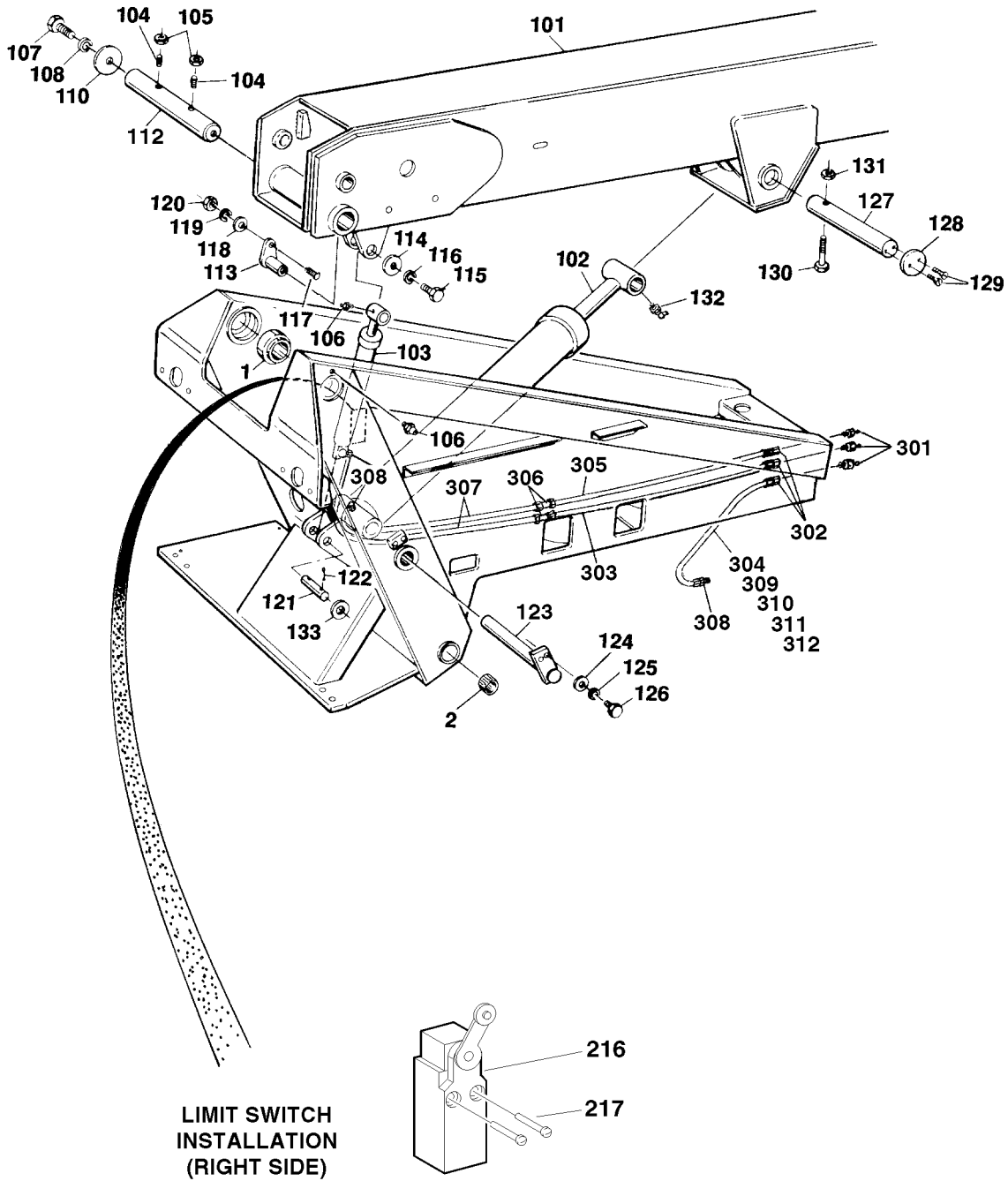



# SECTION 2 TURNTABLE

**FIGURE 2-1. TURNTABLE, BOOM AND SWITCHES INSTALLATION**

FIG & ITEM #	PART NUMBER	DESCRIPTION	QTY.	REV.
		<b>TURNTABLE, BOOM AND SWITCHES INSTALLATION</b>	Ref.	
	4620078	<b>TURNTABLE ASSEMBLY</b>	Ref.	F/6
1	0252852	Boom Pivot Assembly	2	
	0960594	Bushing, Self-Aligning (1 Per Assembly)	2	
2	0961392	Bushing, Bronze (Base Pivot)	2	
		<b>BOOM AND CYLINDERS INSTALLATIONS</b>	Ref.	
	0259903	<b>100SX - CE SPEC</b>	Ref.	1
	0259900	<b>110SX - AUSTRALIAN SPEC</b>	Ref.	2
	0259901	<b>110SX - CE SPEC</b>	Ref.	2
	0259917	<b>110SX - AUSTRALIAN SPEC (WITH INVERTED TRACK)</b>	Ref.	2
	0259912	<b>110SXJ - AUSTRALIAN SPEC</b>	Ref.	3
	0259913	<b>110SXJ - CE SPEC</b>	Ref.	2
	0259918	<b>110SXJ - AUSTRALIAN SPEC (WITH INVERTED TRACK)</b>	Ref.	3
	0259890	<b>120SXJ - AUSTRALIAN SPEC</b>	Ref.	2
	0259891	<b>120SXJ - CE SPEC</b>	Ref.	2
	0270812	<b>120SXJ - W/LENGTH LIMIT CE SPEC</b>	Ref.	1
101		Boom Assembly (See Section 3 for Breakdown)	1	
102		Lift Cylinder Assembly Options: (See Section 5 for Breakdown)	1	
	1682895	100SX/110SX/110SXJ/120SXJ		
	1682895	110SX - Australian Spec (With Inverted Track)		
	1682895	110SXJ - Australian Spec (With Inverted Track)		
103		Master Cylinder Assembly Options: (See Section 5 for Breakdown)	1	
	1681978	100SX/110SX		
	1681978	110SX - Australian Spec (With Inverted Track)		
	1681580	110SXJ/120SXJ		
	1681580	110SXJ - Australian Spec (With Inverted Track)		
104	3952014	Setscrew 5/8"-11NC x 1 3/4"	2	
105	3312002	Nut, Jam 5/8"-11NC	2	
106	2160002	Fitting, Grease	3	
107	0681812	Bolt 1/2"-13NC	4	
108	4740171	Washer, Special Hardened	4	
109	Not Used			
110	1120368	Cap, Boom Pivot	2	
111	Not Used			
112	3422151	Pin, Boom Pivot	1	
113		Pin, Top Master Cylinder Options:	1	
	3421586	100SX/110SX		
	0236548	110SXJ/120SXJ		
114	4740006	Washer, Special (Not Required on 100SX/110SX)	1	
115	0651608	Bolt 3/8"-24NF x 1" (Not Required on 100SX/110SX)	1	
116	4761600	Lockwasher 3/8" (Not Required on 100SX/110SX)	1	
117	4300034	Stud (Welded on Part)	A/R	

**SECTION 2 TURNTABLE**

# SECTION 2 TURNTABLE

**FIGURE 2-1. TURNTABLE, BOOM AND SWITCHES INSTALLATION (CONTINUED)**

FIG & ITEM #	PART NUMBER	DESCRIPTION	QTY.	REV.
118	4751600	Flatwasher 3/8"	A/R	
119	4761600	Lockwasher 3/8"	A/R	
120	3311601	Nut 3/8"-16NC	A/R	
121		Pin, Bottom Master Cylinder Options:	1	
	3422068	100SX/110SX		
	3420085	110SXJ/120SXJ		
122	3450610	Pin, Cotter 3/16" x 2 1/2" (Not Required on 100SX/110SX)	2	
123		Pin, Bottom Lift Cylinder Options:	1	
	3421676	100SX/1110SX/120SXJ		
	3421676	110SX - Australian Spec (With Inverted Track)		
	3422149	110SXJ - Australian Spec (With Inverted Track)		
	3422149	110SXJ - CE Spec		
	3421676	110SXJ - Australian Spec		
124	4712200	Flatwasher 3/4"	2	
125	4762200	Lockwasher 3/4"	2	
126	0682213	Bolt 3/4"-10NC x 1 5/8" (Grade 8)	2	
127		Pin, Top Lift Cylinder Options:	1	
	3421678	100SX/110SX/110SXJ/120SXJ		
	3421678	110SX - Australian Spec (With Inverted Track)		
	3421678	110SXJ - Australian Spec (With Inverted Track) (Prior to S/N 55965)		
	3422150	110SXJ - Australian Spec (With Inverted Track) (S/N 55965 to Present)		
128	4740361	Washer, Special	2	
129	3900159	Screw, Countersunk 1/2"-13NC x 3/4"	4	
130	0641840	Bolt 1/2"-13NC x 5"	1	
131	3311805	Locknut 1/2"-13NC	1	
132	2160001	Fitting, Grease - 90°	1	
133	4740040	Flatwasher, Special (Not Required on 100SX/110SX)	2	
	0100019	----- Loctite #271	A/R	
	0270235	<b>HORIZONTAL CUTOUT LIMIT SWITCH INSTALLATION (RIGHT SIDE)</b>	Ref.	3
201 to 215	Not Used			
216	4360301	Switch, Limit	1	
217	3910812	Screw #8-32NC x 3/4"	2	
	0100011	----- Loctite #242	A/R	
	0239843	<b>LUBE LINES INSTALLATION (100SX/110SX)</b>	Ref.	A
	0239844	<b>LUBE LINES INSTALLATION (110SXJ/120SXJ)</b>	Ref.	3
301	2160002	Fitting, Grease	3	
302	2220001	Fitting	3	
303		Hose Options:	1	
	2750528	100SX/110SX		
	2751032	110SXJ/120SXJ		

**SECTION 2 TURNTABLE**

# SECTION 2 TURNTABLE

**FIGURE 2-1. TURNTABLE, BOOM AND SWITCHES INSTALLATION (CONTINUED)**

FIG & ITEM #	PART NUMBER	DESCRIPTION	QTY.	REV.
304		Hose Options:	1	
	2750529	100SX/110SX		
	2750528	110SXJ/120SXJ		
305	2750807	Hose	1	
306	2200261	Fitting, Nipple	2	
307	2750527	Hose	2	
308	2220063	Fitting	3	
309	4300031	Stud (Welded on Part)	1	
310	4761400	Lockwasher 1/4"	1	
311	3311401	Nut 1/4"-20NC	1	
312	1320040	Clamp, Insulated	1	

SECTION 2 TURNTABLE

# SECTION 2 TURNTABLE

FIGURE 2-2. VALVES INSTALLATION - TURNTABLE MOUNTED

SECTION 2 TURNTABLE

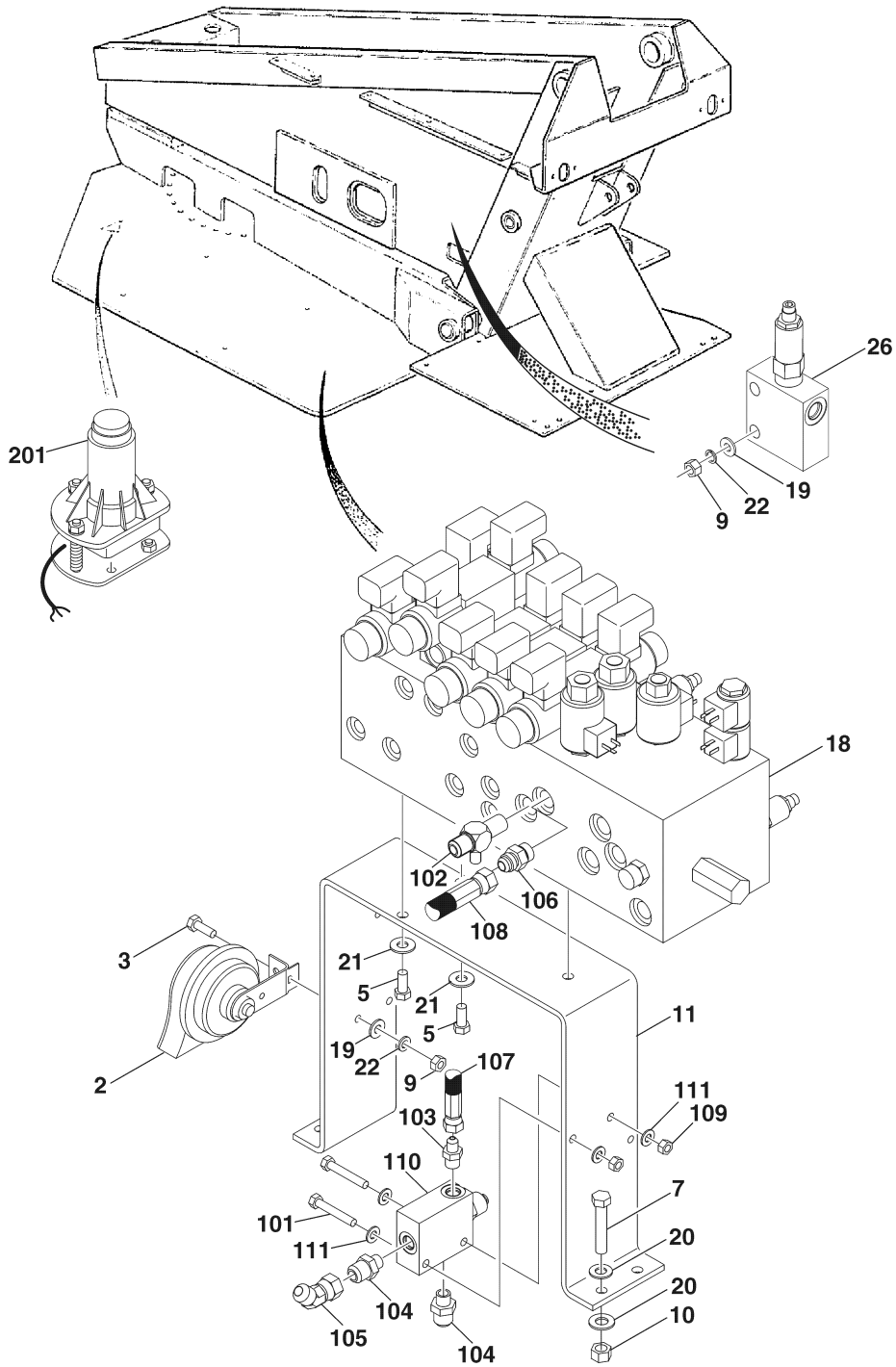

# SECTION 2 TURNTABLE

**FIGURE 2-2. VALVES INSTALLATION - TURNTABLE MOUNTED**

FIG & ITEM #	PART NUMBER	DESCRIPTION	QTY.	REV.
		<b>VALVES INSTALLATION - TURNTABLE MOUNTED</b>	Ref.	
	0270353	<b>VALVES INSTALLATION - 100SX/110SX</b>	Ref.	D
	0259923	<b>VALVES INSTALLATION - 110SXJ/120SXJ</b>	Ref.	F
1	Not Used			
2	0140001	Horn	1	
3	0641406	Bolt 1/4"-20NC x 3/4"	1	
4	Not Used			
5	0641607	Bolt 3/8"-16NC x 7/8"	3	
6	Not Used			
7	0641616	Bolt 3/8"-16NC x 2"	4	
8	Not Used			
9	3311401	Nut 1/4"-20NC	3	
10	3311605	Nut 3/8"-16NC	4	
11	3535942	Plate, Valve Mounting	1	
12 to 17	Not Used			
18		Valve Assembly - Hydro-Air Options: (See Figure 2-3 for Breakdown)	1	
	4641065	100SX/110SX (Prior to S/N 62271)		
	4641181	100SX/110SX (S/N 62271 to Present)		
	4641137	110SXJ/120SXJ (Prior to S/N 62270)		
	4641180	110SXJ/120SXJ (S/N 62270 to Present)		
19	4711400	Flatwasher 1/4" (Narrow)	5	
20	4711600	Flatwasher 3/8" (Narrow)	8	
21	4751600	Flatwasher 3/8" (Wide)	3	
22	4761400	Lockwasher 1/4"	3	
23 to 25	Not Used			
26	4641079	Valve, Counterbalance	1	
	7010123	Cartridge	1	
	2900770	Seal Kit	1	
27 to 28	Not Used			
	0270397	<b>LIFT DOWN HOLDING VALVE INSTALLATION (100SX/110SX/110SXJ WITH OUT JACKS ONLY)</b>	Ref.	B
101	0641516	Bolt 5/16"-18NC x 2"	2	
102	2220373	Fitting, Straight	1	
103	2220582	Fitting, Straight	1	
104	2220600	Fitting, Straight	2	
105	2220683	Fitting, 45°	1	
106	2221061	Fitting, Tee	1	
107	2752435	Hose	1	
108	2752498	Hose	1	
109	3311505	Locknut 5/16"-18NC	2	
110	4640521	Valve, Control	1	
	7004281	Cartridge	1	
	7004282	Seal Kit	1	
111	4711500	Flatwasher 5/16" (Narrow)	4	

**SECTION 2 TURNTABLE**

# SECTION 2 TURNTABLE

FIGURE 2-2. VALVES INSTALLATION - TURNTABLE MOUNTED (CONTINUED)

FIG & ITEM #	PART NUMBER	DESCRIPTION	QTY.	REV.
112	4922448	Harness, Plug Assembly (Not Shown)	1	
	0252926	<b>TILT INDICATOR INSTALLATION</b>	Ref.	3
201	4360363	Switch, Level Sensor - 3°	1	

**S  
E  
C  
T  
I  
O  
N  
  
2  
  
T  
U  
R  
N  
T  
A  
B  
L  
E**

# SECTION 2 TURNTABLE

FIGURE 2-2. VALVES INSTALLATION - TURNTABLE MOUNTED (CONTINUED)

FIG & ITEM #	PART NUMBER	DESCRIPTION	QTY.	REV.

**S  
E  
C  
T  
I  
O  
N  
  
2  
  
T  
U  
R  
N  
T  
A  
B  
L  
E**

# SECTION 2 TURNTABLE

FIGURE 2-3. VALVES ASSEMBLY - HYDRO AIR

SECTION 2 TURNTABLE

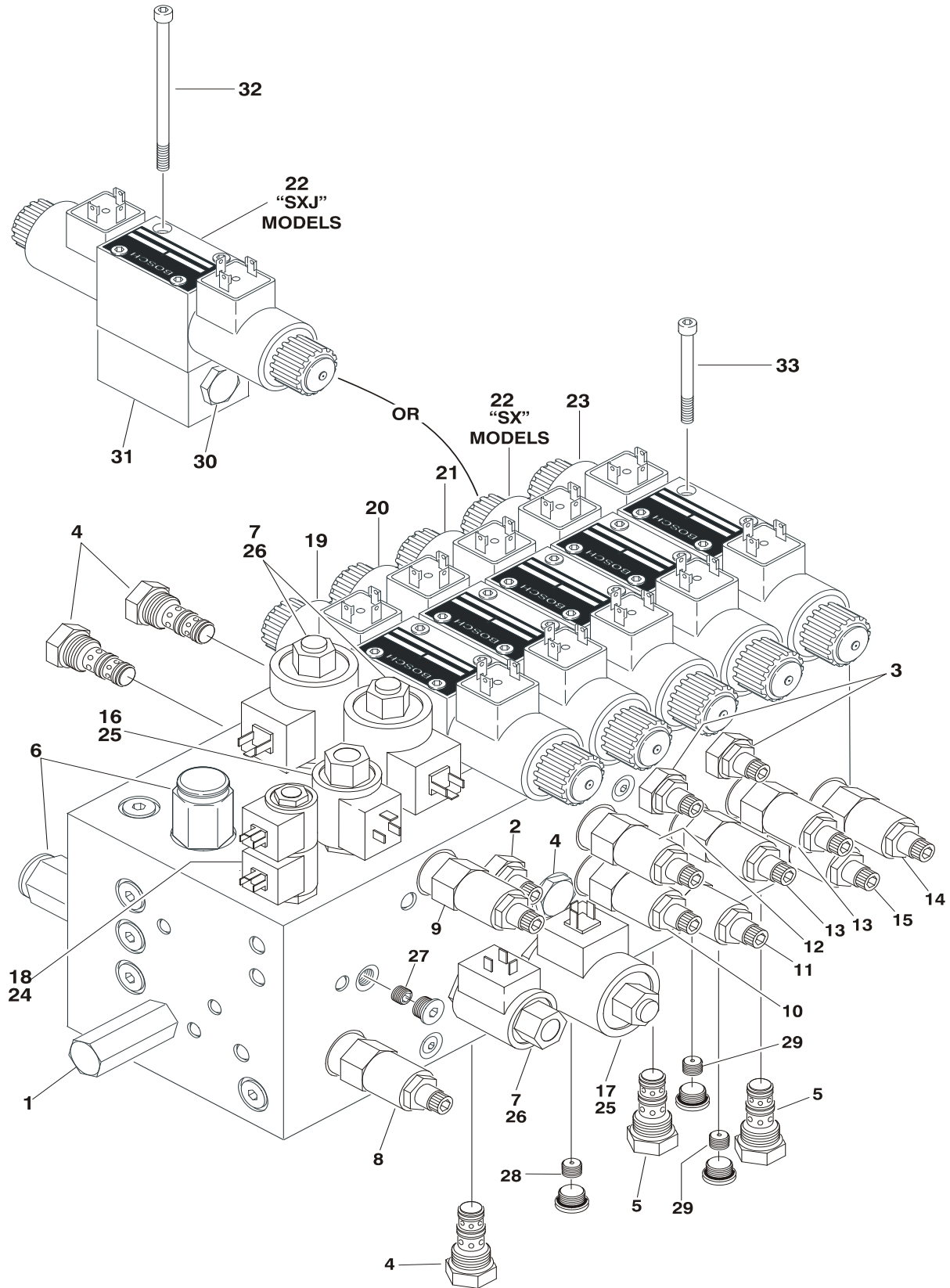



# SECTION 2 TURNTABLE

**FIGURE 2-3. VALVES ASSEMBLY - HYDRO AIR**

FIG & ITEM #	PART NUMBER	DESCRIPTION	QTY.	REV.
		<b>VALVE ASSEMBLY OPTIONS:</b>	Ref.	
	4641065	<b>100SX/110SX Prior to S/N 62271</b>	Ref.	E
	4641181	<b>100SX/110SX S/N 62271 to Present</b>	Ref.	B
	4641137	<b>110SXJ/120SXJ Prior to S/N 62271</b>	Ref.	B
	4641180	<b>110SXJ/120SXJ S/N 62271 to Present</b>	Ref.	B
1	7017482	Cartridge, Valve	1	
	7012518	Seal Kit - 7017482 Cartridge	1	
2	7012997	Cartridge, Flow Control (Lift Down Speed Control)	1	
	7010545	Seal Kit - 7012997 Cartridge	1	
3		Cartridge, Needle Valve/Flow Control Options:	A/R	
	7017483	SX Models uses Cartridge, Flow Control (Not Shown - Looks Similar to Item 4)	2	
	7012953	Seal Kit - 7017483 Cartridge	2	
	7021638	SXJ Models Uses Cartridge, Needle Valve (Shown)	2	
	7012953	Seal Kit - 7021638 Cartridge	2	
4	7010542	Cartridge, Load Shuttle	4	
	7010543	Seal Kit - 7010542 Cartridge (1 Per Cartridge)	4	
5	7012914	Cartridge, Pilot Check	2	
	7012918	Seal Kit - 7012914 Cartridge (1 Per Cartridge)	2	
6	7017484	Cartridge, Pilot Directional	2	
	7012942	Seal Kit - 7017484 Cartridge (1 Per Cartridge)	2	
7		Cartridge, Proportional Valve (Without Coil) (Lift, Swing, Tele, EAR & Rotate)	A/R	
	7017485	SX Models Cartridge (Without Coil)	3	
	Not Available	Seal Kit - 7017485 Cartridge	3	
	7021636	SXJ Models Cartridge (Without Coil)	3	
	7017495	Seal Kit - 7021636 Cartridge	3	
8	7021637	Cartridge, Relief Valve (Main Pressure Adjustment)	1	
	7012972	Seal Kit - 7021637 Cartridge	1	
9	7017487	Cartridge, Relief Valve (Lift Down Pressure)	1	
	7017496	Seal Kit - 7017487 Cartridge	1	
10	7017421	Cartridge, Relief Valve (Swing Pressure)	1	
	7012998	Seal Kit - 7017421 Cartridge	1	
11	7017418	Cartridge, Relief Valve (EAR Up Pressure)	1	
	7012998	Seal Kit - 7017418 Cartridge	1	
12	7017488	Cartridge, Relief Valve (EAR Down Pressure)	1	
	7012998	Seal Kit - 7017488 Cartridge	1	
13	7017422	Cartridge, Relief Valve (Rotate Right, Rotate Left)	2	
	7012998	Seal Kit - 7017422 Cartridge	2	
14	7017489	Cartridge, Relief Valve (Level Down Pressure)	1	
	7012998	Seal Kit - 7017489 Cartridge	1	
15	7017422	Cartridge, Relief Valve (Level Up Pressure)	1	
	7012998	Seal Kit - 7017489 Cartridge	1	
16	7012910	Cartridge, Solenoid Valve (Without Coil) (Main Dump)	1	
	2900708	Seal Kit - 7012910 Cartridge	1	
17	7010635	Cartridge, Solenoid Valve (Without Coil) (Lift Down)	1	
	2900708	Seal Kit - 7010635 Cartridge	1	

**SECTION 2 TURNTABLE**

# SECTION 2 TURNTABLE

**FIGURE 2-3. VALVES ASSEMBLY - HYDRO AIR (CONTINUED)**

**SECTION 2 TURNTABLE**

FIG & ITEM #	PART NUMBER	DESCRIPTION	QTY.	REV.	
18	7017452	Cartridge, Solenoid Valve (Without Coil) (Telescope)	1		
	7017402	Seal Kit - 7017452 Cartridge	1		
	7012944	Coil - 12V	2		
19		Bosch Valve Section - Complete (Lift) Options:	A/R		
	7021622	SX Models Valve Section - Complete	1		
	7021405	Spool (2 Per Section)	1		
	7021401	Coil (2 Per Section)	1		
	7021402	Seal Kit (2 Per Section)	1		
	7021406	Cap, End (2 Per Section)	1		
	7017491	SXJ Models Valve Section - Complete	1		
	7021404	Spool (2 Per Section)	1		
	7021401	Coil (2 Per Section)	1		
	7021402	Seal Kit (2 Per Section)	1		
	7021403	Cap, End (2 Per Section)	1		
	20	7017491	Bosch Valve Section - Complete (Swing)	1	
		7021404	Spool (2 Per Section)	1	
7021401		Coil (2 Per Section)	1		
7021402		Seal Kit (2 Per Section)	1		
7021403		Cap, End (2 Per Section)	1		
21	7017491	Bosch Valve Section - Complete (EAR)	1		
	7021404	Spool (2 Per Section)	1		
	7021401	Coil (2 Per Section)	1		
	7021402	Seal Kit (2 Per Section)	1		
	7021403	Cap, End (2 Per Section)	1		
22	7017490	Bosch Valve Section - Complete (Rotate)	1		
	7021400	Spool (2 Per Section)	1		
	7021401	Coil (2 Per Section)	1		
	7021402	Seal Kit (2 Per Section)	1		
	7021403	Cap, End (2 Per Section)	1		
23	7017491	Bosch Valve Section - Complete (Level)	1		
	7021404	Spool (2 Per Section)	1		
	7021401	Coil (2 Per Section)	1		
	7021402	Seal Kit (2 Per Section)	1		
	7021403	Cap, End (2 Per Section)	1		
24	7012944	Coil	2		
25	7012943	Coil	2		
26	7017451	Coil	3		
27	7017492	Orifice	1		
28	7017493	Orifice	1		
29	7017494	Orifice	2		
30		Cartridge, Check Valve Option:	A/R		
	Not Required	SX Models	0		
	7021639	SXJ Models Uses Check Valve	1		
	2900756	Seal Kit - 7021639 Cartridge	1		
31		Block, Manifold	A/R		
	Not Required	SX Models	0		
	Not Available	SXJ Models Uses Manifold	1		
	7021640	Seal Kit - Manifold Mounting	1		
32	7024827	Screw (SXJ Rotate Section Only)	A/R		

# SECTION 2 TURNTABLE

FIGURE 2-3. VALVES ASSEMBLY - HYDRO AIR (CONTINUED)

FIG & ITEM #	PART NUMBER	DESCRIPTION	QTY.	REV.
33	7024826	Screw	A/R	

**S  
E  
C  
T  
I  
O  
N  
  
2  
  
T  
U  
R  
N  
T  
A  
B  
L  
E**

# SECTION 2 TURNTABLE

FIGURE 2-4. ROTARY COUPLING AND COLLECTOR RING ASSEMBLY AND INSTALLATION

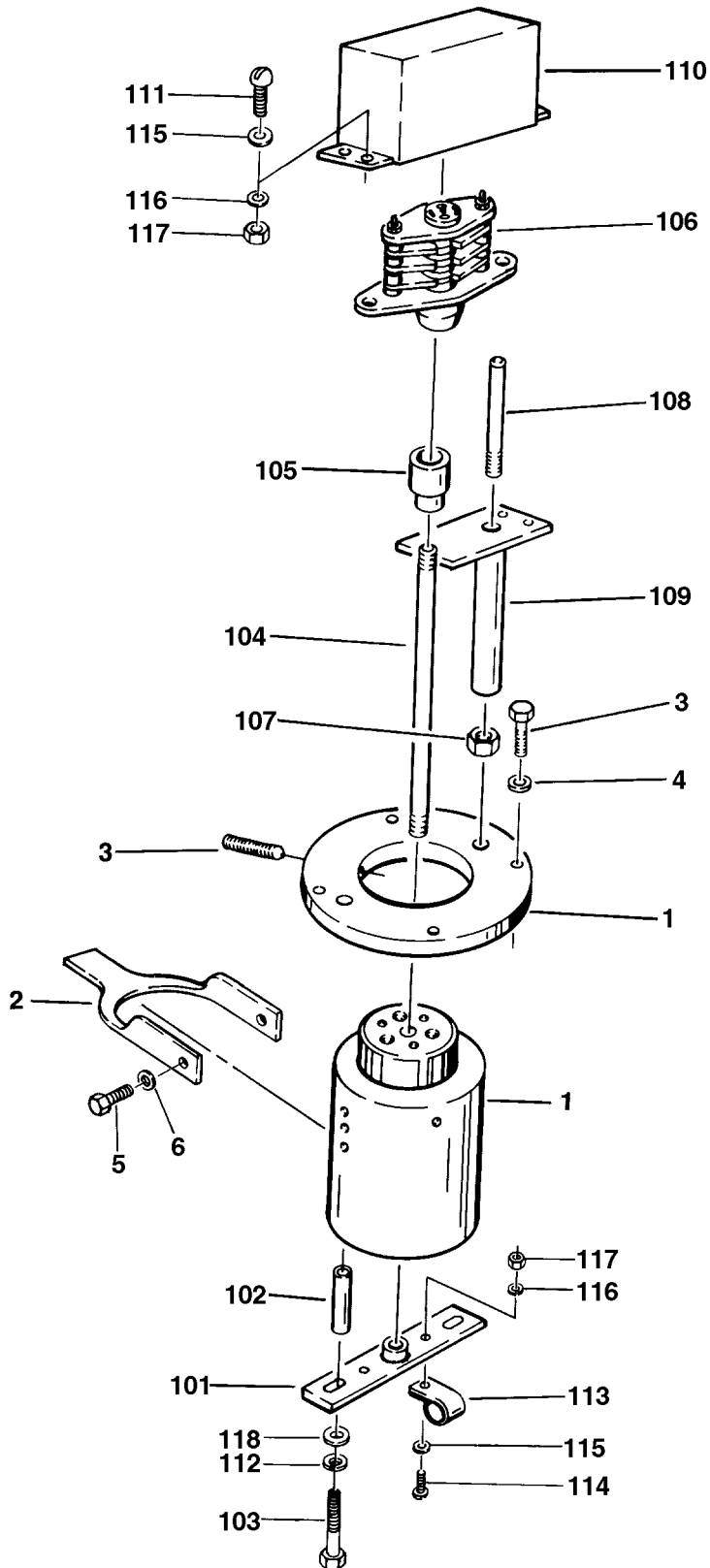

SECTION 2 TURNTABLE

# SECTION 2 TURNTABLE

**FIGURE 2-4. ROTARY COUPLING AND COLLECTOR RING ASSEMBLY AND INSTALLATION**

FIG & ITEM #	PART NUMBER	DESCRIPTION	QTY.	REV.
	0254882	<b>ROTARY COUPLING AND COLLECTOR RING ASSEMBLY AND INSTALLATION</b>	Ref.	3
		<b>ROTARY OIL COUPLING INSTALLATIONS</b>	Ref.	
1	1660213	Rotary Oil Coupling Assembly		
	7019610	Collar	1	
	Use 1660213EX	Rebuilt Couplings (Was P/N 7013175) Note: Due to complexity of repair, seal kit no longer available. Use rebuilt unit as replacement	1	
2	3530403	Plate, Retaining	1	
3	0641514	Bolt 5/16"-18NC x 1 3/4"	4	
4	4761500	Lockwasher 5/16"	4	
5	0641807	Bolt 1/2"-13NC x 7/8"	2	
6	4761800	Lockwasher 1/2"	2	
	0100019	Loctite #271	A/R	
	0270130	<b>COLLECTOR RING INSTALLATION</b>	Ref.	1
101	4843822	Bracket Weldment	1	
102	0960224	Bushing	2	
103	0641418	Bolt 1/4"-20NC x 2 1/4"	2	
104	2180763	Pipe	1	
105	0961531	Bushing	1	
106	3760446	Collector Ring Assembly	1	
107	3311801	Nut 1/2"-13NC	2	
108	3420290	Pin, Drive	2	
109	0231047	Guide, Drive	2	
110	0234721	Cover	1	
111	0721004	Screw, Machine #10-24NC x 1/2"	4	
112	4761400	Lockwasher 1/4"	2	
113	1320040	Clamp, Cable	2	
114	3911012	Screw, Machine	2	
115	4751000	Flatwasher #10	6	
116	4761000	Lockwasher #10	6	
117	3311001	Nut #10-24NC	6	
118	4751400	Flatwasher 1/4"	2	

**SECTION 2 TURNTABLE**

# SECTION 2 TURNTABLE

FIGURE 2-5. SWING DRIVE AND BEARING INSTALLATION.

SECTION 2 TURNTABLE

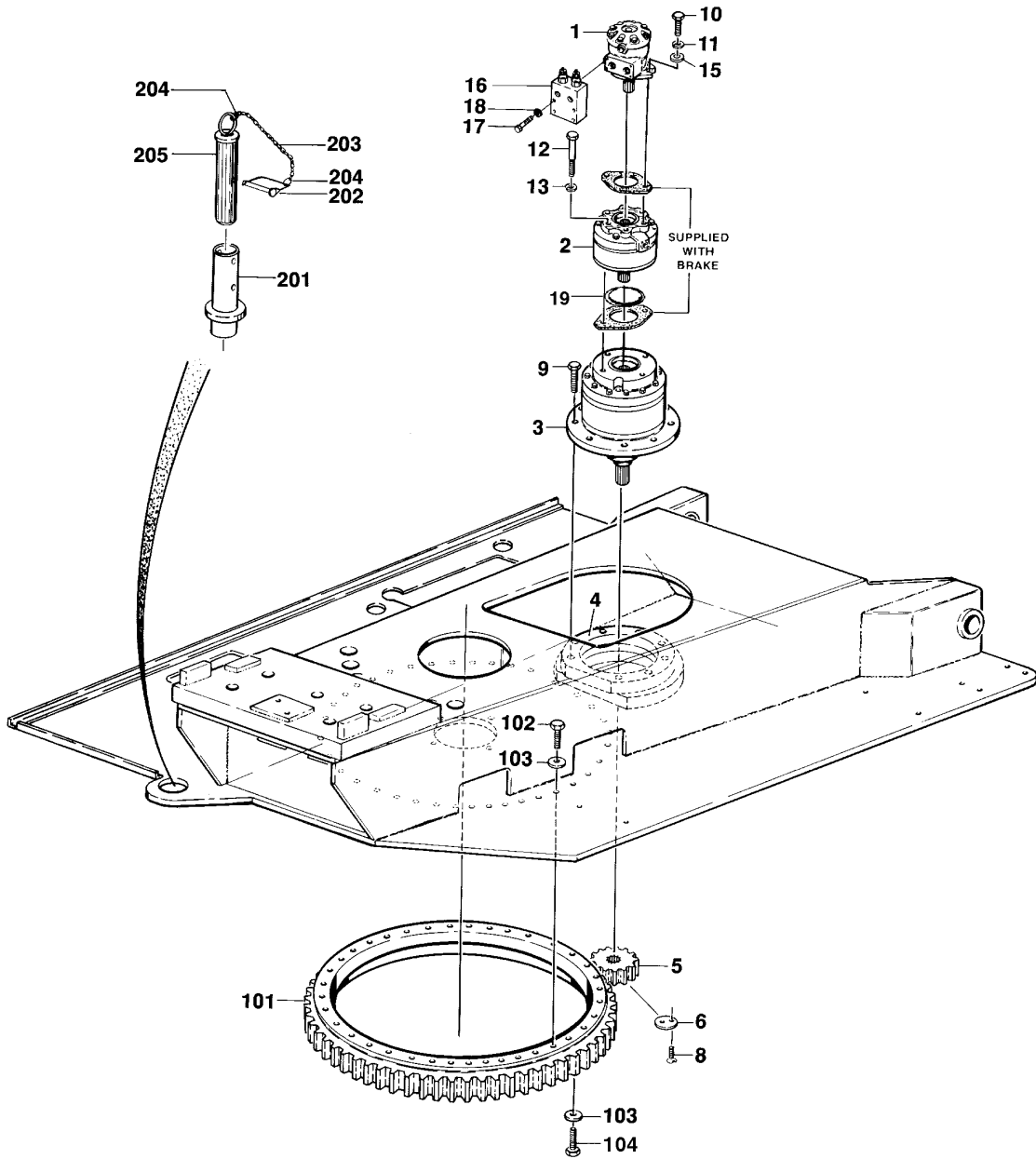

# SECTION 2 TURNTABLE

**FIGURE 2-5. SWING DRIVE AND BEARING INSTALLATION.**

FIG & ITEM #	PART NUMBER	DESCRIPTION	QTY.	REV.
		<b>SWING DRIVE INSTALLATION OPTIONS:</b>		
	0252675	<b>Prior to S/N 64566</b>	Ref.	5
	0270327	<b>S/N 64566 to Present</b>	Ref.	1/A
1		Swing Motor Assembly Options: (See Figure 2-6 for Breakdown)	1	
	3160184	(Prior to S/N 64566)		
	3160276	(S/N 64566 to Present)		
2		Swing Brake Assembly Options: (See Figure 2-7 for Breakdown)	1	
	0920109	(Prior to S/N 64566)		
	0920119	(S/N 64566 to Present)		
3	2780116	Swing Hub Assembly (See Figure 2-8 for Breakdown)	1	
4	4844109	Mounting Weldment - Swing Drive	1	
5	2440058	Gear, Pinion	1	
6	3533337	Plate, Retaining	1	
7	Not Used			
8	3900164	Screw, Countersunk 1/2"-20NF x 1"	2	
9	0642216	Bolt 3/4"-10NC x 2"	8	
10		Bolt/Screw Options:	2	
	0641810	(Bolt)1/2"-13NC x 1 1/4" (Prior to S/N 64566)		
	0681832	(Screw)1/2"- 13NC x 4" (S/N 64566 to Present)		
11	4761800	Lockwasher 1/2"	2	
12	3931864	Bolt, Socket Head 1/2"-13NC x 4" (Grade 8) (Prior to S/N 64566)	2	
13	4740189	Washer, Special (Prior to S/N 64566)	2	
14	Not Used			
15	4740171	Washer, Special Hardened (Prior to S/N 64566)	2	
16	4640741	Motor Control Valve Assembly	1	
	7011320	Cartridge	2	
	2900770	Seal Kit	2	
17	0641520	Bolt 5/16"-18NC x 2 1/2"	4	
18	4761500	Lockwasher 5/16"	4	
19	3790155	O-Ring	1	
		-----		
	0100019	Loctite #271 (Prior to S/N 64566)	A/R	
	0100009	Sealant, Pipe (Prior to S/N 64566)	A/R	
	0100011	Loctite #242 (S/N 64566 to Present)	A/R	
	0270062	<b>TURNTABLE BEARING INSTALLATION</b>	Ref.	3
101	0440193	Bearing	1	
102	0682016	Bolt 5/8"-11NC x 3 1/4"	40	
103	4892000	Washer, Special Hardened	80	
104	0682024	Bolt 5/8"-11NC x 3"	40	
		-----		
	0100019	Loctite #271	A/R	

**SECTION 2 TURNTABLE**

# SECTION 2 TURNTABLE

**FIGURE 2-5. SWING DRIVE AND BEARING INSTALLATION. (CONTINUED)**

FIG & ITEM #	PART NUMBER	DESCRIPTION	QTY.	REV.
	0239842	<b>TURNTABLE LOCK INSTALLATION</b>	Ref.	B
201	4843318	Bushing Weldment	1	
202	3421565	Pin, Snap	1	
203	1260017	Chain - #3	9 in/23cm	
204	3760170	Ring, Quick Release	2	
205	3421563	Pin, Turntable Lock	1	

**SECTION 2 TURNTABLE**



# SECTION 2 TURNTABLE

FIGURE 2-5. SWING DRIVE AND BEARING INSTALLATION. (CONTINUED)

FIG & ITEM #	PART NUMBER	DESCRIPTION	QTY.	REV.

**S  
E  
C  
T  
I  
O  
N  
  
2  
  
T  
U  
R  
N  
T  
A  
B  
L  
E**

# SECTION 2 TURNTABLE

FIGURE 2-6. SWING MOTOR ASSEMBLY

SECTION 2 TURNTABLE

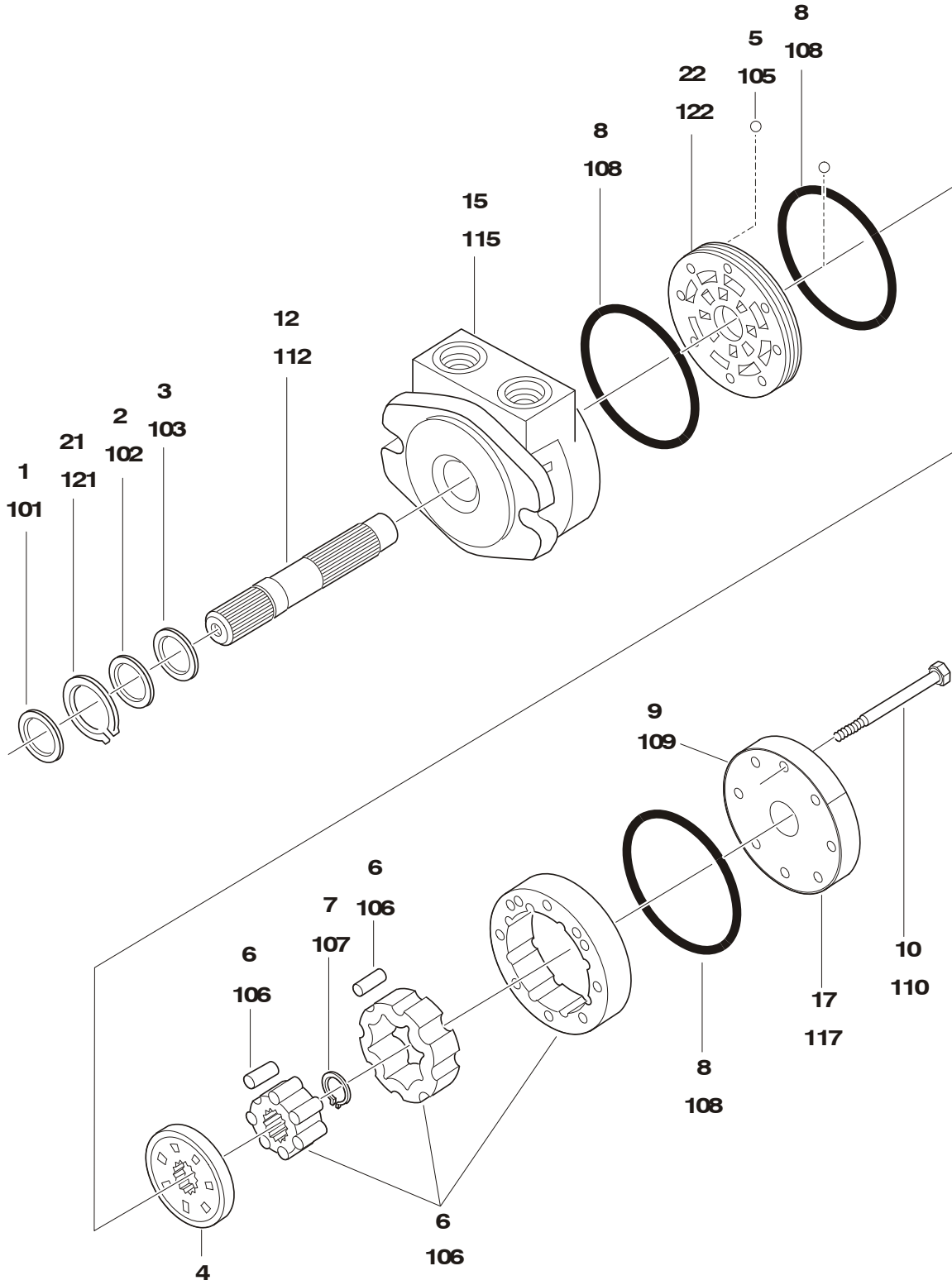

# SECTION 2 TURNTABLE

**FIGURE 2-6. SWING MOTOR ASSEMBLY**

FIG & ITEM #	PART NUMBER	DESCRIPTION	QTY.	REV.
	3160184	<b>SWING MOTOR ASSEMBLY (PRIOR TO S/N 64566)</b>	Ref.	B
1	Kit	Seal, Dust	1	
2	Kit	Ring, Back-Up	1	
3	Kit	Seal, Lip	1	
4	7004196	Valve, Rotary	1	
5	7004167	Ball, Check Valve	2	
6	7004179	IGR Assembly	1	
7	Kit	Ring, Snap	1	
8	Kit	Seal, Ring	3	
9	7004171	Plug, Vent (Includes O-Ring)	1	
10	7010780	Bolt	8	
11	Not Used			
12	7010781	Shaft, Spline	1	
13 to 14	Not Used			
15	7010782	Body/Bearing Assembly	1	
16	Not Used			
17	7004192	Cover/Bearing Assembly	1	
18 to 20	Not Used			
21	Kit	Ring, Retaining	1	
22	7010776	Plate, Commutator	1	
	2900798	Seal Kit (Includes Items 1,2,3,7,8 and 21)	1	
	3160276	<b>SWING MOTOR ASSEMBLY (S/N 64566 TO PRESENT)</b>	Ref.	A
101	Kit	Seal, Dust	1	
102	Kit	Ring, Back-Up	1	
103	Kit	Seal, Lip	1	
104	Not Used			
105	7004167	Ball, Check Valve	2	
106	7010791	IGR Assembly	1	
107	Kit	Ring, Snap	1	
108	Kit	Seal, Ring	3	
109	7010795	Plug, Vent (Includes O-Ring)	1	
110	7010792	Bolt	8	
111	Not Used			
112	7023432	Shaft, Spline	1	
113 to 114	Not Used			
115	7023443	Body/Bearing Assembly	1	
116	Not Used			
117	7004192	Cover/Bearing Assembly	1	
118 to 120	Not Used			
121	Kit	Ring, Retaining	1	
122	7010776	Plate, Commutator	1	
	2900798	Seal Kit (Includes Items 101,102,103,107,108 and 121)	1	

**SECTION 2 TURNTABLE**

# SECTION 2 TURNTABLE

FIGURE 2-7. SWING BRAKE ASSEMBLY

SECTION 2 TURNTABLE

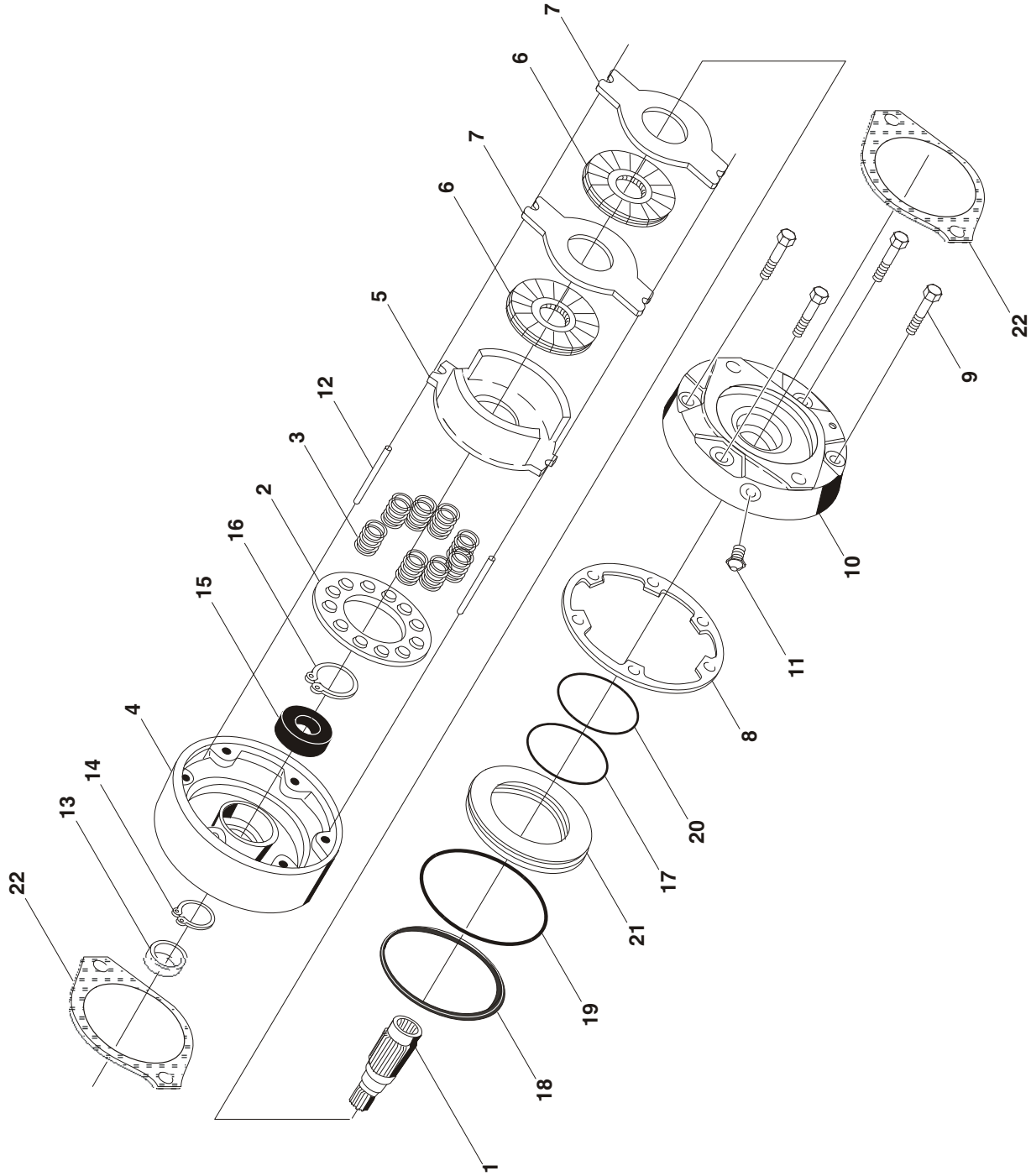

# SECTION 2 TURNTABLE

**FIGURE 2-7. SWING BRAKE ASSEMBLY**

FIG & ITEM #	PART NUMBER	DESCRIPTION	QTY.	REV.
	0920109	<b>SWING BRAKE ASSEMBLY (PRIOR TO S/N 64566)</b>	Ref.	B
1	7011720	Shaft	1	
2	7018606	Guide, Spring	1	
3	7007970	Spring (Red)	6	
4	7018605	Housing	1	
5	Kit	Plate, Separator	1	
6	Kit	Rotor	2	
7	Kit	Stator	2	
8	Kit	Seal, Case	1	
9	7018607	Bolt, Washer Head	4	
10	7011719	Cover	1	
11	7018609	Plug	1	
12	7007987	Pin, Dowel	2	
13	Kit	Seal, Oil	1	
14	7011716	Ring, Retaining	1	
15	Kit	Bearing	1	
16	7007977	Ring, Retaining	1	
17	Kit	Ring, Back-up (Inner)	1	
18	Kit	Ring, Back-up (Outer)	1	
19	Kit	O-Ring (Outer)	1	
20	Kit	O-Ring (Inner)	1	
21	7018603	Piston	1	
22	7007934	Gasket	2	
	7018608	Lining Kit (Includes Items 5,6,7,8 and 22)	1	
	2900766	Seal Kit (Includes items 8,13,17,18,19,20 and 22)	1	
	2900768	Bearing Kit (Includes Items 8,13,14,15,16 and 22)	1	
	0920119	<b>SWING BRAKE ASSEMBLY (S/N 64566 TO PRESENT)</b>	Ref.	A
	7018612	Kit, Repair <b>Note: Repair Kit Only</b>	1 Ref.	

SECTION 2 TURNTABLE

# SECTION 2 TURNTABLE

FIGURE 2-8. SWING HUB ASSEMBLY

SECTION 2 TURNTABLE

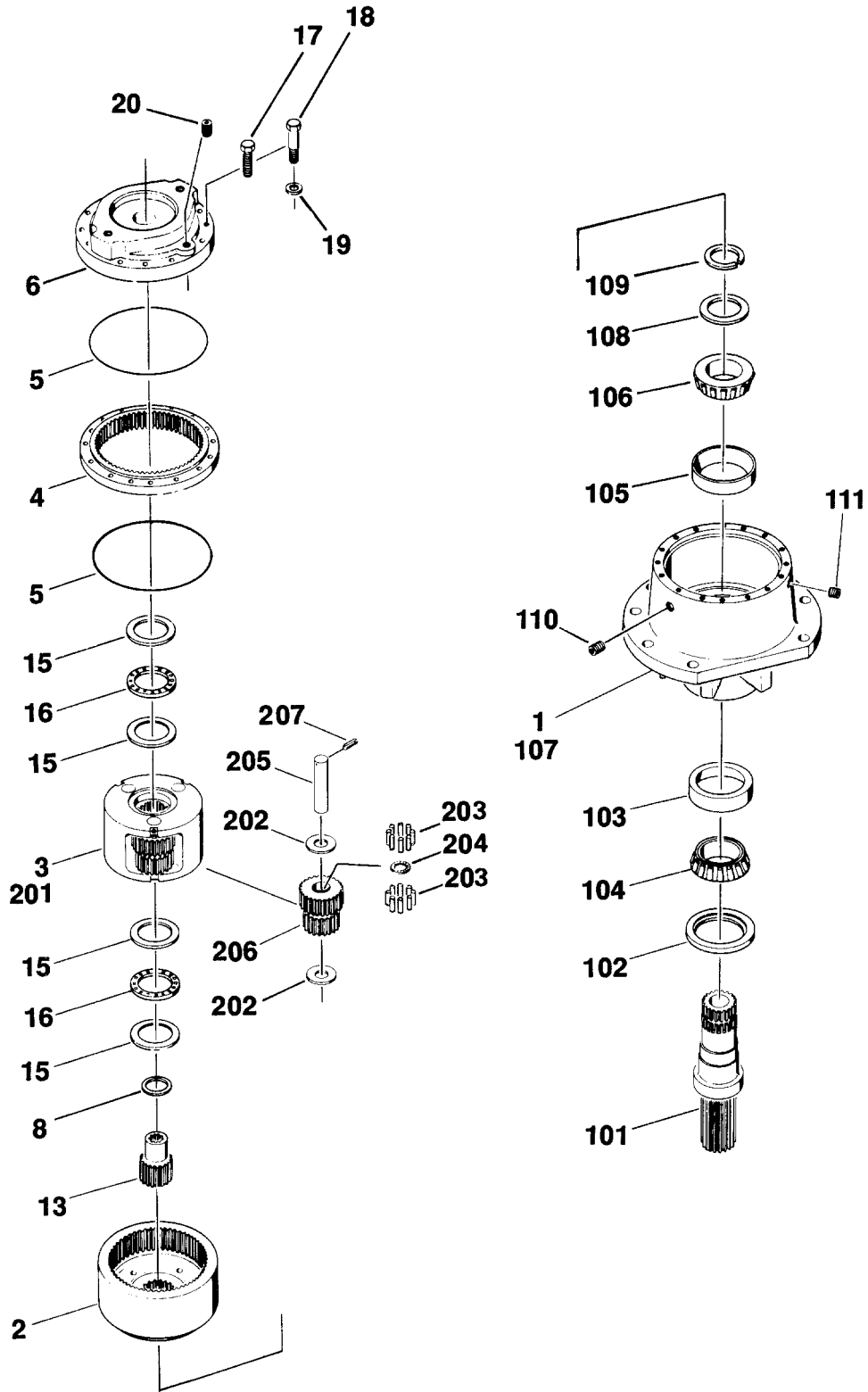

# SECTION 2 TURNTABLE

**FIGURE 2-8. SWING HUB ASSEMBLY**

FIG & ITEM #	PART NUMBER	DESCRIPTION	QTY.	REV.
	2780116	<b>SWING HUB ASSEMBLY</b>	Ref.	—
1	7001916	Hub and Spindle Assembly (See Items 101-111 for Breakdown)	1	
2	7001917	Gear, Internal	1	
3	7001918	Carrier Assembly (See items 201-207 for Breakdown)	1	
4	7000279	Gear, Ring	1	
5	Kit	O-Ring	2	
6	7001920	Cover	1	
7	Not Used			
8	7001922	Washer, Thrust	1	
9	Not Used			
10	Not Used			
11	Not Used			
12	Not Used			
13	7001921	Gear, Input	1	
14	Not Used			
15	7000287	Washer, Thrust	4	
16	7000288	Bearing, Thrust	2	
17	7001923	Bolt	8	
18	7001924	Bolt, Shoulder	4	
19	7001929	Lockwasher	4	
20	7001926	Plug, Pipe	1	
	7001916	<b>HUB AND SPINDLE ASSEMBLY</b>	Ref.	
101	7001982	Shaft, Output	1	
102	Kit	Seal, Lip	1	
103	7000272	Cup, Bearing	1	
104	7000273	Cone, Bearing	1	
105	7000274	Cup, Bearing	1	
106	7000275	Cone, Bearing	1	
107	Not Available	Hub	1	
108	Kit	Spacer	1	
109	Kit	Ring, Retaining	1	
110	7001928	Plug, Pipe	1	
111	7001926	Plug, Pipe	2	
	7001918	<b>CARRIER ASSEMBLY</b>	Ref.	
201	Not Available	Housing, Carrier	1	
202	Kit	Washer, Thrust	6	
203	7001902	Bearing, Needle	84	
204	Kit	Spacer	3	
205	7001904	Shaft, Planet	3	
206	Kit	Gear, Cluster	3	
207	Kit	Rollpin	3	
	2900202	Seal Kit (Includes Items 5, 102, 108 and 109)	1	
	7001927	Cluster Gear Kit (Includes Items 202, 204,206 and 207)	1	

SECTION 2 TURNTABLE

# SECTION 2 TURNTABLE

FIGURE 2-9. LOAD MANAGEMENT INSTALLATION

SECTION 2 TURNTABLE

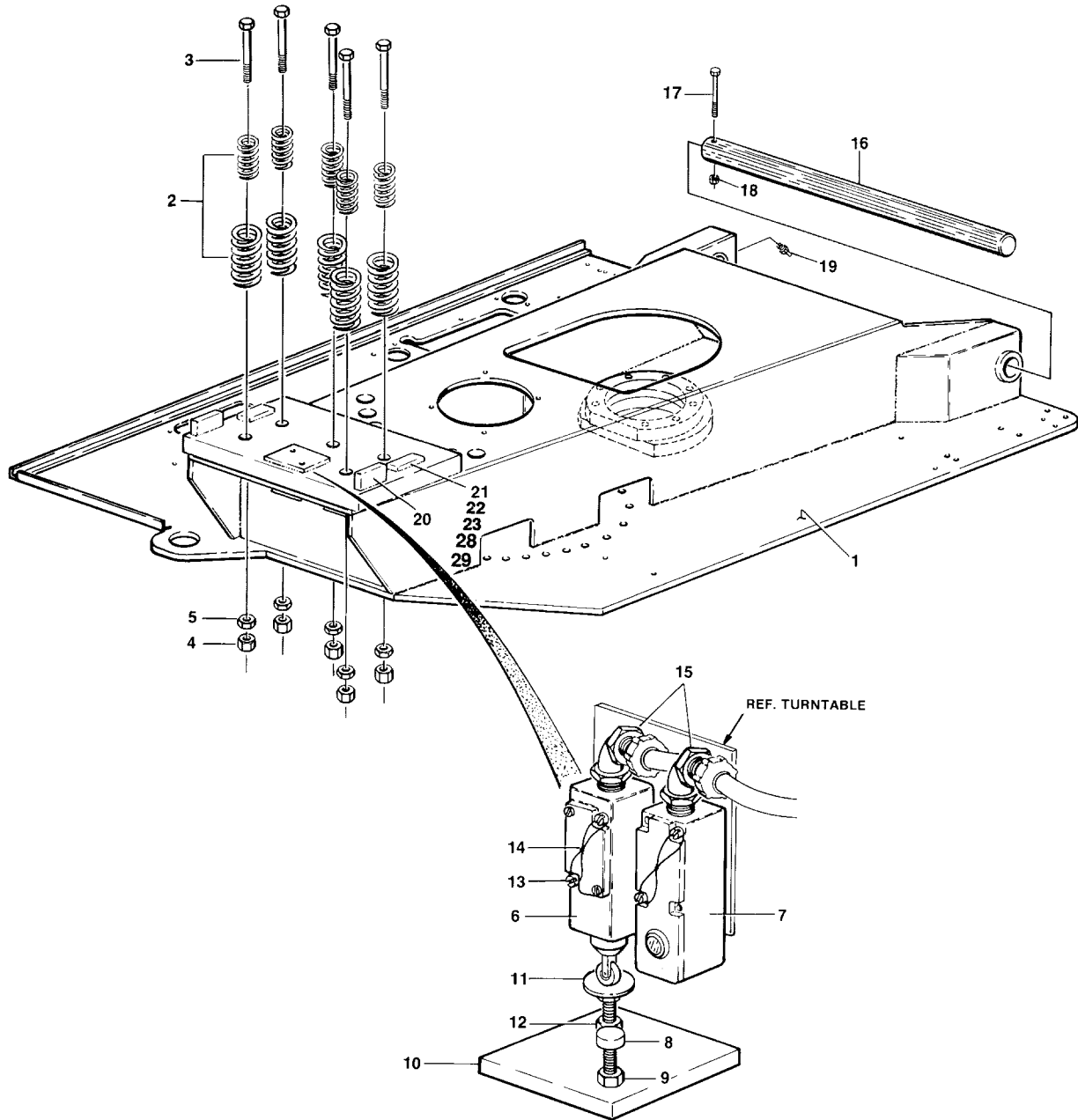



# SECTION 2 TURNTABLE

**FIGURE 2-9. LOAD MANAGEMENT INSTALLATION**

FIG & ITEM #	PART NUMBER	DESCRIPTION	QTY.	REV.
	0239868	<b>LOAD MANAGEMENT INSTALLATION</b>	Ref.	7
1	4844272	Base Weldment	1	
2	4160099	Spring	5	
3	0630422	Bolt 1 1/4"-&NC x 14"	5	
4	3313002	Nut, Jam 1 1/4"-7NC	5	
5	3273001	Nut 1 1/4"-7NC (Grade 8)	5	
6	4360263	Switch, Limit	1	
7	4360259	Switch, Proximity	1	
8	3841004	Rod, Actuator	1	
9	3321501	Nut 5/16"-18	1	
10	3533414	Plate, Actuator Mounting	1	
11	0630510	Bolt, Leveler	1	
12	3321405	Locknut 1/4"-28NF	1	
13	3900104	Screw, Drilled Head #10-24NC x 2 1/4"	4	
14	4920140	Lockwire	2	
15	4460342	Connector, Strain Relief	2	
16	3421677	Pin, Load Moment Pivot	1	
17	0642252	Bolt 3/4"-10NC x 6 1/2"	1	
18	3312205	Locknut 3/4"-10NC	1	
19	2160002	Fitting, Grease	2	
20	4220120	Stop, Turntable	2	
21	4220121	Stop, Turntable	A/R	
22	4070729	Shim 11 GA x 1 1/2" x 4"	A/R	
23	4070728	Shim 16 GA x 1 1/2" x 4"	A/R	
24	Not Used			
25	Not Used			
26	Not Used			
27	Not Used			
28	4220157	Stop, Turntable 1/2" x 1 1/2" x 4"	A/R	
29	4220158	Stop, Turntable 1/4" x 1 1/2" x 4"	A/R	
	0100019	----- Loctite	A/R	

**SECTION 2 TURNTABLE**

# SECTION 2 TURNTABLE

FIGURE 2-10. GROUND CONTROLS INSTALLATION

SECTION 2 TURNTABLE

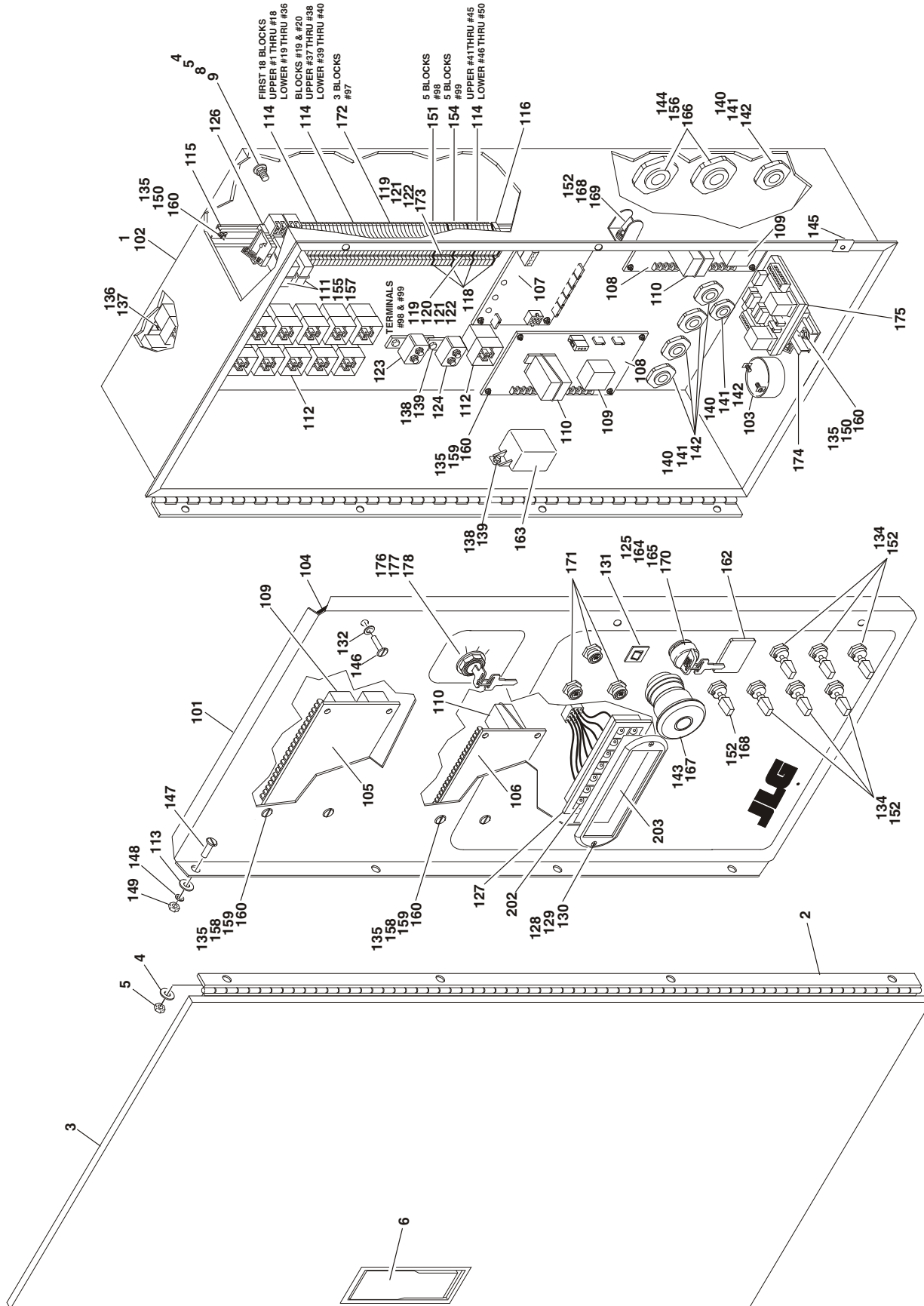

# SECTION 2 TURNTABLE

**FIGURE 2-10. GROUND CONTROLS INSTALLATION**

FIG & ITEM #	PART NUMBER	DESCRIPTION	QTY.	REV.
		<b>GROUND CONTROLS INSTALLATIONS:</b>	Ref.	
	0270372	<b>100SX/110SX</b>	Ref.	1
	0270373	<b>110SXJ</b>	Ref.	1
	0270371	<b>120SXJ</b>	Ref.	1
	0270838	<b>120SXJ W/LENGTH LIMIT</b>	Ref.	1
1		Ground Control Box Assembly - Deutz Options: (See Items 101-180 for Breakdown)	1	
	0861373	100SX/110SX		
	0861374	110SXJ		
	0861372	120SXJ		
	0861406	120SXJ W/Length Limit		
2	2600148	Hinge	1	
3	1780227	Door, Ground Control	1	
4	4751400	Flatwasher 1/4"	14	
5	3311401	Nut 1/4"-20NC	14	
6	2940042	Latch	1	
7	Not Used			
8	4300032	Stud (Welded on Part)	4	
9	4751500	Flatwasher 5/16"	8	
		-----		
	0100011	Loctite #242	A/R	
		<b>GROUND CONTROL BOX ASSEMBLIES:</b>	Ref.	
	0861373	<b>100SX/110SX</b>	Ref.	2
	0861374	<b>110SXJ</b>	Ref.	2
	0861372	<b>120SXJ</b>	Ref.	2
	0861406	<b>120SXJ W/Length Limit</b>	Ref.	1
101		Lid/Nameplate Options:	1	
	3252670	Standard		
	3252763	W/Length Limit		
102		Box Options:	1	
	0860562	Standard		
	0861362	W/Length Limit		
103	0140019	Alarm	1	
104	4420037	Gasket	15 ft./4.5m	
105	0610084	Card, Circuit (Engine Relay)	1	
106	0610080	Card, Circuit (Select)	1	
107	0610130	Card, Circuit (Load Radius)	1	
108	0610100	Card, Circuit (Overload)	2	
109	3740070	Relay - SPDT	16	
110	3740016	Relay - 3PDT	6	
111	3740122	Relay - 2PDT	A/R	
112	3740049	Relay - 5PDT (With Skirt)	A/R	
113	4750800	Flatwasher #8	6	
114	4460301	Marker, Terminal (1-50)	1	
115	3640686	Rail	1	

**SECTION 2 TURNTABLE**

# SECTION 2 TURNTABLE

**FIGURE 2-10. GROUND CONTROLS INSTALLATION (CONTINUED)**

FIG & ITEM #	PART NUMBER	DESCRIPTION	QTY.	REV.
116	4460442	Stop, Terminal	1	
117	4460387	Block, Terminal	36	
118	4460388	Barrier, Terminal	5	
119	4460307	Sleeve, Terminal	22	
120	4460441	Bar, Buss - 5 Position	2	
121	4460306	Washer, Terminal	22	
122	4460305	Screw, Terminal	22	
123	4360216	Breaker, Circuit - 30 Amp	1	
124	4360232	Breaker, Circuit - 15 Amp	1	
125	4360470	Switch, Key (Master Select)	1	
	2860030	Key, Replacement	1	
126	4460299	Stop, Terminal	A/R	
127	2760105	Housing, Display Light	1	
128	1670829	Bezel	1	
129	0630518	Screw	2	
130	3300408	Locknut, Plastic Inserted	2	
131	4360212	Breaker, Circuit - 3 Amp	1	
132	4740120	Washer, Nylon	3	
133	Not Used			
134	4360314	Switch, Toggle (Extend-A-Reach, Lift, Swing, Level, Telescope and Rotate)	A/R	
135	4760600	Lockwasher #6	24	
136	4751400	Flatwasher 1/4"	8	
137	3311401	Nut 1/4"-20NC	8	
138	4751000	Flatwasher #10	3	
139	3311001	Nut #10-24NC	3	
140	4460051	Connector, Strain Relief	A/R	
141	3300048	Nut, Conduit	5	
142	0960238	Bushing, Reducer	A/R	
143	4360475	Switch, Emergency Stop	1	
	7020175	Cap, Red	1	
	7020176	Contact Block	1	
144	4460386	Connector, Strain Relief	2	
145	3300177	Nut, Tinnerman	3	
146	0750806	Screw, Self-Tapping #8 x 3/4"	3	
147	0720804	Screw, Hex #8-32NC x 1/2"	6	
148	4760800	Lockwasher #8	6	
149	3310801	Nut #8-32NC	6	
150	3910606	Screw, Hex #6-32NC x 3/8"	2	
151	4460451	Strip, Terminal Marking - #98	12	
152	3790012	O-Ring	A/R	
153	4460234	Clamp, Cable (Not Shown)	10	
154	4460452	Strip, Terminal Marking - #99	20	
155	4120036	Base, Relay	A/R	
156	3300147	Nut, Conduit	2	
157	3740124	Spring, Relay	A/R	
158	3910616	Screw, Hex #6-32NC x 1"	10	
159	4564088	Stand-Off #6-32NC x 1/4"	22	
160	3310601	Nut #6-32NC	A/R	
161	Not Used			

**SECTION 2 TURNTABLE**

# SECTION 2 TURNTABLE

**FIGURE 2-10. GROUND CONTROLS INSTALLATION (CONTINUED)**

FIG & ITEM #	PART NUMBER	DESCRIPTION	QTY.	REV.
162	2420172	Hourmeter	1	
163	3740112	Relay, Ignition	1	
164	4070991	Shim .125	1	
165	4070987	Shim .015	1	
166	0960905	Bushing	2	
167	4360476	Block, Contact	1	
168	4360328	Switch, Toggle (Proximity Manual Test)	A/R	
169	4060229	Guard, Switch	A/R	
170	3910804	Screw #8-32NC x 1/4"	6	
171	4360069	Breaker, Circuit - 10Amp	3	
172	4460704	Strip, Terminal marking - #97	12	
173	4460390	Buss Bar, Terminal	4	
174	3640493	Rail, Mounting	1	
175	0610141	Card, Overload Monitoring	1	
176	4360284	Switch, Key (W/Length Limit Only)	1	
	7010698	Key, Replacement	1	
177	4360267	Block W/Contact (W/Length Limit Only)	1	
178	4360281	Contact Block (W/Length Limit Only)	1	
179	Not Used			
180	4460071	Relief, Strain (W/Length Limit Only)	1	
	0259886	<b>LIGHT PANEL DECAL INSTALLATION</b>	Ref.	1
201	Not Used			
202	2920129	Bulb, Light	A/R	
203	1704517	Decal - Light Panel Display	1	

SECTION 2 TURNTABLE

# SECTION 2 TURNTABLE

FIGURE 2-11. REMOTE DRIVE CONTROL BOX ASSEMBLY

SECTION 2 TURNTABLE

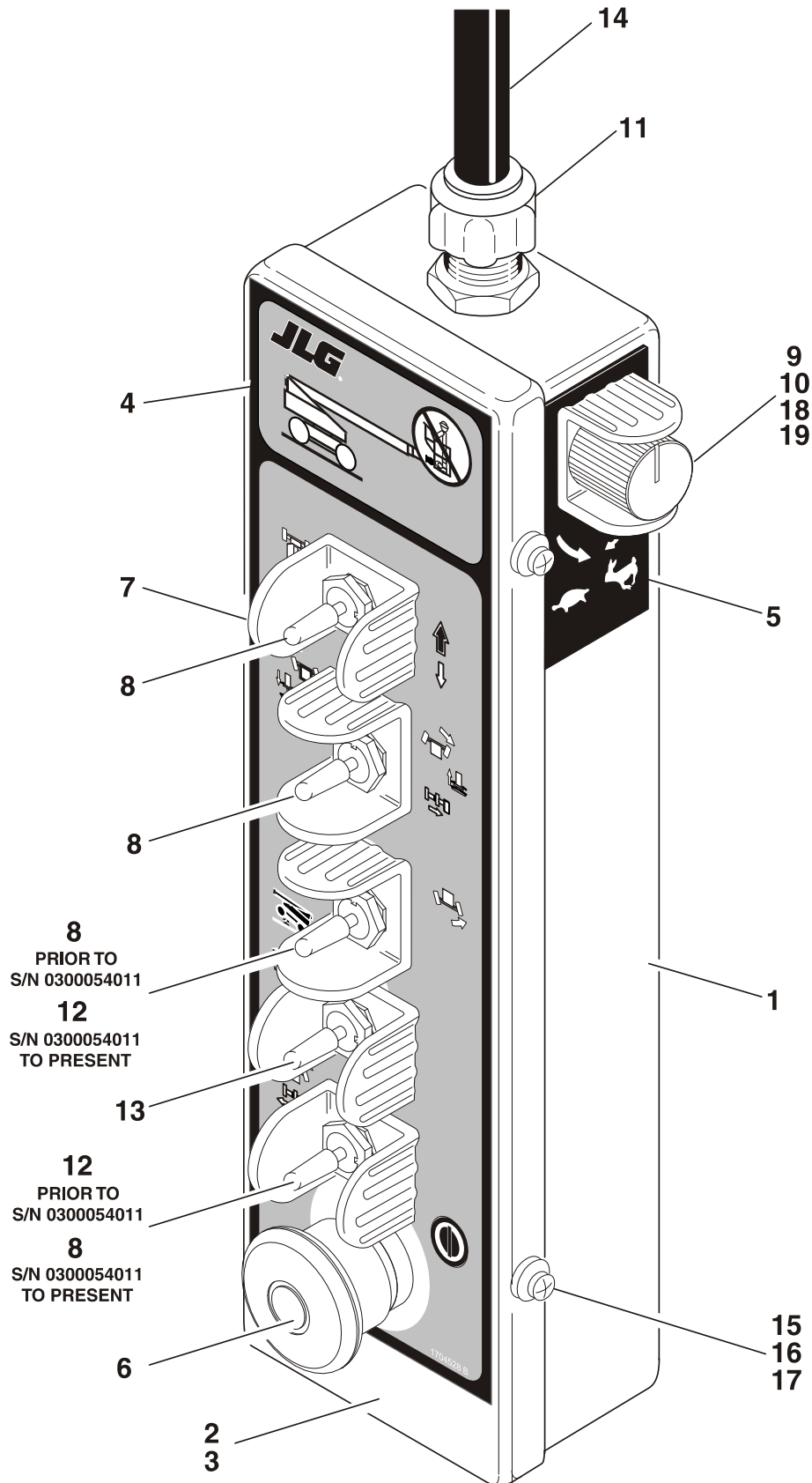

# SECTION 2 TURNTABLE

**FIGURE 2-11. REMOTE DRIVE CONTROL BOX ASSEMBLY**

FIG & ITEM #	PART NUMBER	DESCRIPTION	QTY.	REV.
	0270048	<b>REMOTE DRIVE CONTROL BOX ASSEMBLY</b>	Ref.	2/C
1	0861354	Box, Remote	1	
2	3572216	Plate, Remote Box Lid	1	
3	4420037	Tape, Insulation	A/R	
4	1704528	Decal, Remote Box	1	
5	1701775	Decal, Potentiometer	1	
6	4360475	Switch, Emergency Stop	1	
7	4060802	Shield, Toggle	6	
8	4360314	Switch, Toggle	3	
9	4360340	Switch, Potentiometer	1	
10	3300352	Nut, Special	1	
11	4460425	Connector, Strain	1	
12	4360331	Switch, Toggle	1	
13	4360345	Switch, Toggle	1	
14	1060306	Cable, Control 16/16	25 ft.	
15	4740120	Washer, Nylon	4	
16	3300177	Nut, Tinnerman #8	4	
17	0750804	Screw #8 x 1/2 Lg.	4	
18	2560116	Knob, Speed Control (Black)	1	
19	4711600	Flatwasher 3/8"	1	
		-----		
	3730091	Resistor (Not Shown)	1	
	3990001	Diode (Not Shown)	10	

SECTION 2 TURNTABLE





# SECTION 2 TURNTABLE

**FIGURE 2-12. DEUTZ F4L-912 ENGINE INSTALLATION**

FIG & ITEM #	PART NUMBER	DESCRIPTION	QTY.	REV.
	0270272	<b>DEUTZ F4L-912 ENGINE INSTALLATION</b>	Ref.	2
1	2000083	Engine - Deutz Diesel F4L-912	1	
	2000115	Engine - Deutz Diesel F4L-912 - Clean Burn	1	
2	3600260	Pump Assembly - Sunstrand (See Figure 2-15 for Breakdown)	1	
3	3200229	Motor Support Weldment (Front)	1	
4	3200228	Motor Support Weldment (Rear)	2	
5	3200133	Mount, Rubber Motor (Front)	1	
6	3200183	Mount, Rubber Motor (Rear)	2	
7	3200227	Plate, Engine Mounting (Front)	1	
8	3200306	Plate, Engine Mounting (Rear)	1	
9	3600286	Pump Assembly - Barnes (See Figure 2-16 For Breakdown)	1	
10	0901829	Bracket, Filter	1	
11	2120135	Filter - Charge Pump	1	
	2120136	Element	1	
12	1060044	Cable, Battery (Starter to Ground)	1	
13	0641812	Bolt 1/2"-13NC x 1 1/2"	2	
14	4761800	Lockwasher 1/2"	2	
15	0250069	Fuel Shutdown Kit (Includes Mounting Hardware)	1	
16	0642032	Bolt 5/8"-11NC x 4"	3	
17	3312005	Locknut 5/8"-11NC	3	
18	4740242	Flatwasher, Special	3	
19	0701427	Bolt, Metric 14mm x 100mm	4	
20	4740191	Lockwasher, Metric 14.2mm	4	
21	0701215	Bolt, Metric 12mm x 35mm	8	
22	4832100	Lockwasher 12mm	8	
23	4891600	Flatwasher 3/8"	2	
24	0641620	Bolt 3/8"-16NC x 1 1/4"	2	
25	0100011	Loctite #242 (Not Shown)	A/R	
26	0701015	Bolt, Metric 10mm x 35mm	2	
27	4831700	Lockwasher 6mm	1	
28	3311401	Nut 1/4"-20NC	3	
29	0641405	Bolt 1/4"-20NC x 5/8"	4	
30	4761400	Lockwasher #1/4"	4	
31	Not Used			
32	0700617	Bolt, Metric 6mm x 45mm	5	
33	0237627	Electrical Panel Assembly (See Items 201-211 for (Breakdown)	1	
34	0237635	Throttle Cable Installation (See Items 301-315 for Breakdown)	1	
35	4640742	Valve, Oil Drain	1	
36	2720042	Hose, Heater	6 in./15cm	
37	4832000	Lockwasher, Metric 10mm	2	
38	3290607	Locknut, Metric 6mm	4	
39	1320222	Clamp (Not Shown)	3	
40	4360490	Switch, Oil Pressure	1	
41	4811700	Flatwasher 6mm	9	
42	4843384	Air Intake Weldment	1	

**SECTION 2 TURNTABLE**

# SECTION 2 TURNTABLE

**FIGURE 2-12. DEUTZ F4L-912 ENGINE INSTALLATION (CONTINUED)**

FIG & ITEM #	PART NUMBER	DESCRIPTION	QTY.	REV.
43	4565269	Adapter, Exhaust	1	
44	4751700	Flatwasher 7/16"	1	
45	0700810	Bolt, Metric 8-1.25mm x 20mm	1	
46		Coupling Installations (See Figure 2-14 for Breakdown)	1	
47	4844238	Tube Weldment	1	
48	1670627	Cover, Base Plate	1	
49	1340020	Air Cleaner Assembly	1	
	7004214	Element	1	
50	0340002	Band, Mounting	2	
51	0080046	Elbow	1	
52	0080039	Elbow	2	
53	4565655	Tube	1	
54	2720224	Hose 2 3/4" ID x 3" Lg.	1	
55	1320058	Clamp	8	
56	4300031	Stud (Welded on Part)	8	
57	4761400	Lockwasher 1/4"	6	
58	3311401	Nut 1/4"-20NC	12	
59	0400020	Battery (Large)	1	
60	0236768	Rod, Tie-Down	4	
61	0361027	Bar, Hold-Down	1	
62	3980006	Seat, Battery	1	
63	0400003	Battery (Small)	1	
64	0400002	Hold-Down	1	
	2910479	Clips	4	
65	3980003	Seat, Battery	1	
66	4751400	Flatwasher 1/4"	23	
67	3300029	Wingnut 1/4"-20NC	4	
68	1060031	Cable, Battery (Large Battery to Ground)	1	
69	1060109	Cable, Battery (Large Battery to Starter)	1	
70	1060149	Cable, Battery (Starter to Aux. Relay)	1	
71	1060132	Cable, Battery (Aux. Relay to Aux. Pump)	1	
72	4300034	Stud (Welded on Part)	3	
73	4921139	Cable, Battery (Positive to Positive - Batteries)	1	
	3990048	Diode (Soldered to Cable)	1	
74	0642022	Bolt 5/8"-11NC x 2 3/4"	2	
75	4752000	Flatwasher 5/8"	2	
76	4762000	Lockwasher 5/8"	2	
77	3312001	Nut 5/8"-11NC	2	
78	0641622	Bolt 3/8"-16NC x 2 3/4"	2	
79	4751600	Flatwasher 3/8"	3	
80	4761600	Lockwasher 3/8"	11	
81	3311601	Nut 3/8"-16NC	5	
82		Auxiliary Pump Assembly Options:	1	
	Use 3600468	Auxiliary Pump Assembly (See Items 501-503 for Breakdown) (was p/n 3600208)	1	
	3600468	Auxiliary Pump Assembly (See Items 551-553 for Breakdown)		
83	0641620	Bolt 3/8"-16NC x 2 1/2"	2	
84	2720271	Fuel Line (Return)	8 ft./2.4m	
85	2750532	Fuel Line (Supply)	10 ft./3m	

**SECTION 2 TURNTABLE**

# SECTION 2 TURNTABLE

**FIGURE 2-12. DEUTZ F4L-912 ENGINE INSTALLATION (CONTINUED)**

FIG & ITEM #	PART NUMBER	DESCRIPTION	QTY.	REV.
86	2220063	Fitting, 90°	2	
87	2220720	Fitting, Barbed	2	
88	0641414	Bolt 1/4"-20NC x 1 3/4"	13	
89	1320022	Clamp	4	
90	0253194	Air Inlet Box Assembly	1	
91	4280002	Neoprene 1/8" x 2"	30 in./76cm	
92	1320059	Clamp	1	
93	2180536	Fitting, Coupling	1	
94	3311405	Locknut 1/4"-20NC	13	
95	1060031	Cable, Battery (Small Battery to Ground)	1	
96	4751500	Flatwasher 5/16"	2	
97	4740362	Washer, Fender	6	
98	4761500	Lockwasher 5/16"	2	
99	3535949	Plate, Hose Cover	1	
100	0362101	Bar, Spacer	1	
101	3536008	Plate, Shield	1	
102	1320021	Clamp, Muffler	1	
103	4831900	Flatwasher 8mm	1	
104	3790152	"O" Ring	1	
	0237627	<b>ELECTRICAL PANEL ASSEMBLY</b>	Ref.	7
201	3740059	Relay	1	
202	3321001	Nut #10-32NF	3	
203	3310801	Nut #8-32NC	1	
204	3530425	Plate, Mounting	1	
205	3740080	Relay, Sealed	1	
206	3740067	Relay	2	
207	3300220	Nut, Special	6	
208	0641405	Bolt 1/4"-20NC x 5/8"	7	
209	4791400	Starwasher 1/4"	7	
210	3311401	Nut 1/4"-20NC	7	
211	4711400	Flatwasher 1/4"	6	
	0237635	<b>THROTTLE CABLE INSTALLATION</b>	Ref.	4
301	0060023	Actuator	1	
	7008804	Bellows, Rubber	1	
	7008829	Board, Circuit	1	
	7008821	Motor, Drive	1	
	7008828	Cable, Throttle	1	
302	0901389	Bracket, Throttle Cable	1	
303	4460302	Stop, Terminal	1	
304	3450203	Pin, Cotter 1/16" x 3/4"	1	
305	4711400	Flatwasher 1/4" Narrow	1	
306	0641409	Bolt 1/4"-20NC x 1 1/8"	2	
307	4751400	Flatwasher 1/4"	2	
308	0630400	Bolt, Metric 8mm - 1.25 x 90mm	2	
309	4831900	Lockwasher 8mm	2	

**SECTION 2 TURNTABLE**

# SECTION 2 TURNTABLE

**FIGURE 2-12. DEUTZ F4L-912 ENGINE INSTALLATION (CONTINUED)**

FIG & ITEM #	PART NUMBER	DESCRIPTION	QTY.	REV.
310	3290801	Nut, Metric 8mm - 1.25	2	
311	1320041	Clamp	1	
312	4761400	Lockwasher 1/4"	3	
313	4751600	Flatwasher 3/8"	2	
314	0641406	Bolt 1/4"-20NC x 3/4"	1	
315	3311401	Nut 1/4"-20NC	1	
	0270271	<b>EXHAUST INSTALLATION</b>	Ref.	1
401	4751400	Flatwasher 1/4"	4	
402	3220082	Muffler	1	
403	0340041	Band, Mounting	1	
404	0901849	Bracket, Exhaust Mounting	1	
405	0641408	Bolt 1/4"-20NC x 1"	2	
406	3311405	Locknut 1/4"-20NC	2	
407	0641408	Bolt 1/4"-20NC x 1"	4	
408	4751400	Flatwasher 1/4"	4	
409	3311405	Locknut 1/4"-20NC	4	
410	1120423	Cap, Rain	1	
411	4844235	Stack, Exhaust	1	
412	4565751	Tube, Exhaust	1	
413	1320011	Clamp, Muffler	2	
	3600208	<b>AUXILIARY PUMP ASSEMBLY</b>	Ref.	A
501	7013711	Coupling	1	
502	7013710	Motor 12VDC	1	
	7013753	Brush Kit	1	
503	7013712	Pump	1	
	3600468	<b>AUXILIARY PUMP ASSEMBLY</b>	Ref.	A
551	7011016	Coupling	1	
552	7011003	Motor 12VDC	1	
553	70001108	Replacement Pump Kit (Includes all Items Below)	1	
	7012576	Bracket, Mounting		
	7011044	Gasket, Mounting		
	7011016	Coupling		
	70000969	Seal, Shaft		
	Use Item 553	Stator		
	70001079	Cap Assembly		
	70001076	Spring		
	70001081	Ball		
	70001080	Seat		
	7011024	Seal		
	7011048	Washer		
	7011043	Screw		
	70000970	Ring, Retaining		
	70000971	Gear		

**SECTION 2 TURNTABLE**

# SECTION 2 TURNTABLE

**FIGURE 2-12. DEUTZ F4L-912 ENGINE INSTALLATION (CONTINUED)**

FIG & ITEM #	PART NUMBER	DESCRIPTION	QTY.	REV.
	70001112	Shaft, Idler		
	70001065	Pin, Drive		
	70000976	Bearing, Needle		
	7010911	Pin, Dowel		
	70001085	Gasket		
	Use Item 553	Housing, Gear		
	Not Available	Label		
	70001106	Screw		
	70001107	Shaft, Drive		
	Use Item 200B	Plug		
	0270293	<b>ENGINE DISTRESS INSTALLATION</b>	Ref.	1/A
601	4360179	Switch, Temp Head (Not Shown) (Located Under Top Engine Cover)	1	
602 to 604	Not Required			
	0270834	<b>LOW OIL PRESSURE SHUTDOWN INSTALLATION</b>	Ref.	1
701	Not Used			
702	3740080	Relay	1	
		<b>ENGINE COMPONENTS</b>	Ref.	
	7000663	Alternator (Bosch)	1	
	7000872	Alternator (Delco-Remy)	1	
	7000661	Starter	1	
	7000700	Manifold, Exhaust	1	
	7000697	Belt, Blower	1	
	7000698	Belt, Alternator	1	
	7000699	Gasket, Doughnut Exhaust	1	
	7026125	Counter/Exhaust Flange (3 Hole)	1	
	7014686	Engine Kit (includes 12 each of 3 Different Fuel Line Washers, 1 each of Oil Plug Washer, Oil Filter and Fuel Filter)		
	Use 7029274	Filter, Fuel (was p/n 7000649)	1	
	Use 7029276	Filter, Oil (was p/n 7000648)	1	
	7014503	Filter, Oil (Case of 12)	1	
	70002252	Ring, Head Fire	4	
	70002253	Gasket Set (Complete Engine)	1	
	70002254	Kit, Piston/Cylinder	4	
	70002258	Bolt, Cylinder Head	4	
	70002259	Washer, Cylinder Head Bolt	4	
	70001361	Pump, Fuel Injection	4	
	70001927	Manifold, Exhaust	1	
	70001928	Gasket, Exhaust Manifold	4	
	7016330	Switch, Oil Pressure	1	
	7019607	Solenoid, Fuel Shutdown	1	
	7016364	Pump, Fuel Lift	2	
	7020208	Gear, Ring	1	

**SECTION 2 TURNTABLE**

# SECTION 2 TURNTABLE

**FIGURE 2-12. DEUTZ F4L-912 ENGINE INSTALLATION (CONTINUED)**

**SECTION 2 TURNTABLE**

FIG & ITEM #	PART NUMBER	DESCRIPTION	QTY.	REV.
	7020400	Washer/Fuel Line	1	
	7020401	Washer	1	
	7020402	Washer/Fuel Line	1	
	7020403	Washer/Fuel Line	1	
	7020405	Washer/Oil Plug	1	
	7020407	Gasket, Lift Pump	1	
	7020409	Dipstick	1	
	Use 7000663	Alternator (was p/n 7020410)	1	
	7020413	Starter	1	
	7020420	Starter, Remanufactured	1	
	7020421	Nozzle, Injector	1	
	7020422	Injector	1	
	7020423	Gasket, Injector Tip	1	
	7020432	Kit, Lift Pump Repair	1	
	7020433	Gasket	1	
	7020498	Fan	1	
	7026125	Flange, Exhaust	1	
	7026173	Switch, Broken Belt	1	
	7027250	Spring, Tension (Actuator)	1	

# SECTION 2 TURNTABLE

FIGURE 2-12. DEUTZ F4L-912 ENGINE INSTALLATION (CONTINUED)

FIG & ITEM #	PART NUMBER	DESCRIPTION	QTY.	REV.

**S  
E  
C  
T  
I  
O  
N  
  
2  
  
T  
U  
R  
N  
T  
A  
B  
L  
E**

# SECTION 2 TURNTABLE

FIGURE 2-13. PUMP COUPLING INSTALLATION

SECTION 2 TURNTABLE

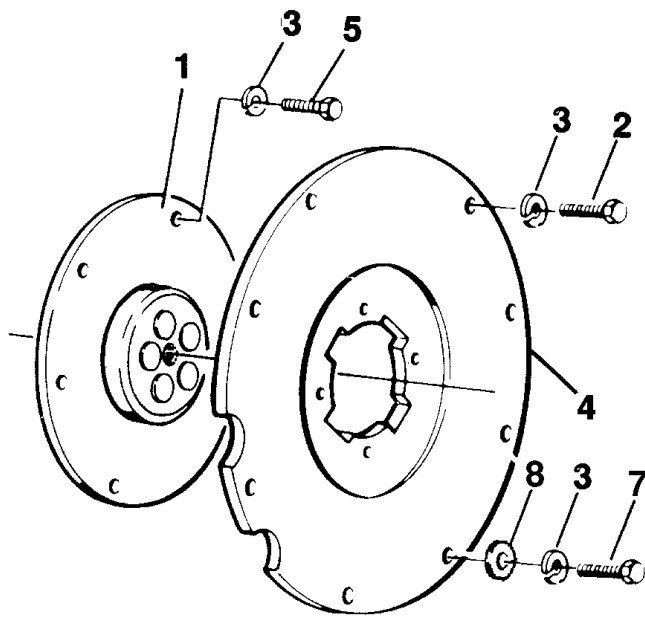



# SECTION 2 TURNTABLE

**FIGURE 2-13. PUMP COUPLING INSTALLATION**

FIG & ITEM #	PART NUMBER	DESCRIPTION	QTY.	REV.
	0256849	<b>PUMP COUPLING INSTALLATION - HAYES</b>	Ref.	2
1	1660233	Coupling, Pump - Hayes	1	
2	0701014	Bolt, Metric 10mm x 30mm	10	
3	4832000	Lockwasher 10mm	18	
4	0080164	Plate, Adaptor	1	
5	0701010	Bolt, Metric 10mm x 20mm	6	
6	Not Used			
7	0701015	Bolt, Metric 10mm x 35mm	2	
8	4751600	Flatwasher 3/8"	2	
	3020021	----- Grease	A/R	

SECTION 2 TURNTABLE

# SECTION 2 TURNTABLE

FIGURE 2-14. PUMP ASSEMBLY - SUNSTRAND

SECTION 2 TURNTABLE

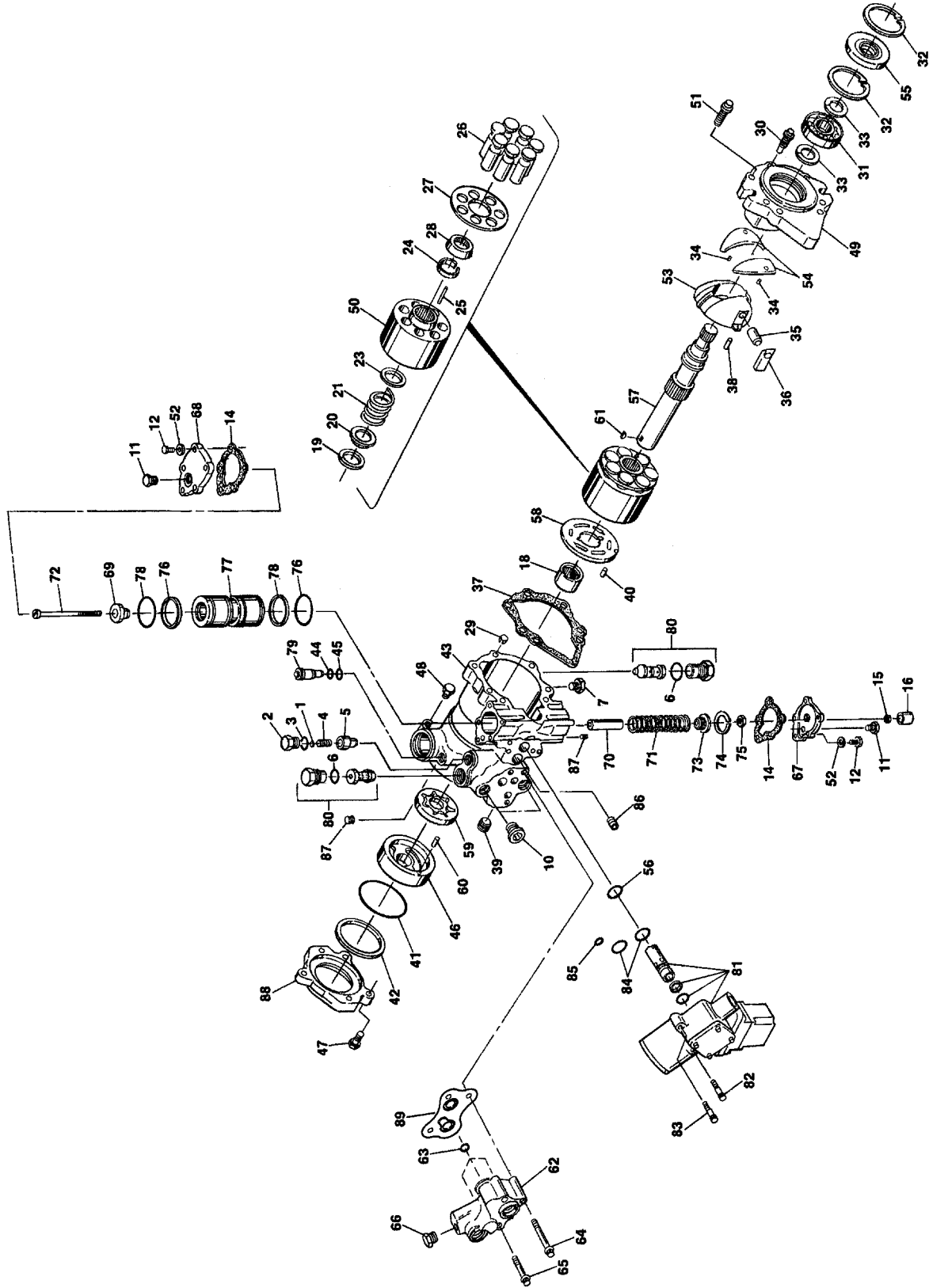

# SECTION 2 TURNTABLE

**FIGURE 2-14. PUMP ASSEMBLY - SUNSTRAND**

FIG & ITEM #	PART NUMBER	DESCRIPTION	QTY.	REV.
	3600260	<b>PISTON PUMP ASSEMBLY - SUNSTRAND</b>	Ref.	B
1	7007413	Shim Kit - Relief Valve	1	
2	7007414	Plug	1	
3	Kit	O-Ring	1	
4	7007416	Spring, Relief Valve	1	
5	7007417	Valve, Relief	1	
6	Kit	O-Ring	2	
7	7007419	Plug	2	
8	Not Used			
9	Not Used			
10	7007420	Plug	2	
11	7007208	Plug	2	
12	7007421	Screw	10	
13	Not Used			
14	7007422	Gasket, Servo Cover	2	
15	7007423	Nut, Special	1	
16	7007424	Cover, Adjustment	1	
17	Not Used			
18	7007425	Bearing, Needle	1	
19	Kit	Ring, Retaining	1	
20	Kit	Washer	1	
21	Kit	Spring	1	
22	Not Used			
23	Kit	Washer	1	
24	Kit	Retainer	1	
25	Kit	Pin, Slipper Holddown	3	
26	Kit	Piston Assembly	7	
27	Kit	Guide, Slipper	1	
28	Kit	Guide, Retainer	1	
29	7007435	Pin, Spring	1	
30	7007436	Screw - 12 Point Head	1	
31	7007437	Bearing, Ball	1	
32	7007438	Ring	2	
33	7007439	Ring	2	
34	7007440	Pin, Spring	2	
35	7007441	Handle, Pin	1	
36	7007442	Sleeve, Bearing	1	
37	Kit	Gasket, Front Cover	1	
38	7007444	Pin	1	
39	7007445	Plug, Expansion	1	
40	Kit	Pin	1	
41	Kit	O-Ring	1	
42	Kit	Ring, Load Temper	1	
43	7007449	Housing, Pump	1	
44	Kit	Ring, Back-Up	1	
45	Kit	O-Ring	1	
46	Kit	Cover, Gerotor	1	
47	7007453	Bolt, Hex	3	

SECTION 2 TURNTABLE

# SECTION 2 TURNTABLE

**FIGURE 2-14. PUMP ASSEMBLY - SUNSTRAND (CONTINUED)**

**SECTION 2 TURNTABLE**

FIG & ITEM #	PART NUMBER	DESCRIPTION	QTY.	REV.
48	7007208	Plug	1	
49	7007454	Cover, Front	1	
50	Kit	Block, Cylinder	1	
51	7007456	Screw - 12 Point Head	6	
52	7001438	Washer	10	
53	Kit	Swashplate	1	
54	7007458	Journal, Bearing	1	
55	Kit	Seal, Lip	1	
56	Kit	O-Ring	1	
57	7010121	Shaft, Main Pump	1	
58	Kit	Plate, Valve	1	
59	Kit	Gerotor Assembly	1	
60	Kit	Pin	1	
61	Kit	Key, Woodruff	1	
62	7007466	Adaptor, Remote Filtration (Without Bypass)	1	
63	Kit	O-Ring	3	
64	7007468	Screw	2	
65	7007469	Screw	2	
66	7007470	Plug	1	
67	7007471	Cover, Servo (With Adjuster)	1	
	7007490	Stop, Servo (Not Shown)	2	
	7007491	Nut, Special (Not Shown)	2	
	7007492	Ring, External (Not Shown)	2	
68	7007482	Cover, Servo (Without Adjuster)	1	
69	7007483	Guide, Spring	1	
70	7007484	Stop, Servo	1	
71	7007485	Spring	1	
72	7007486	Screw	1	
73	7007487	Guide, Spring	1	
74	7007488	Ring, Retaining	1	
75	7007499	Locknut	1	
76	Kit	Ring, Piston	2	
77	7007494	Piston, Servo	1	
78	Kit	O-Ring	2	
79	7007472	Valve, By-Pass	1	
80	Use 7010122	Valve, Pressure Release (Includes Item 6) (Was P/N 7007473)	2	
81	7007474	Control, Dual Oil-Filled	1	
	7007496	Coil Assembly (Pilot)	1	
	7007497	Plug (Pump)	1	
	7007498	Plug (Valve Harness)	1	
82	7007478	Screw	2	
83	7001498	Screw	2	
84	Kit	O-Ring	2	
85	Kit	O-Ring	1	
86	7007475	Plug, Orifice/Screen -.156	1	
87	7007477	Plug, Orifice -.37	2	
88	7007476	Adapter, Auxiliary Pump	1	
89	7010120	Spacer/Gasket	1	
		-----		

# SECTION 2 TURNTABLE

**FIGURE 2-14. PUMP ASSEMBLY - SUNSTRAND (CONTINUED)**

FIG & ITEM #	PART NUMBER	DESCRIPTION	QTY.	REV.
	2900752	Seal Kit - Complete (Includes Items 3,6,14,15,37,41,42,44,45,55,56,63,76,78,84 and 85)	1	
	7007412	Seal Kit - Servo Piston (Includes Items 76 and 78)	1	
	2900826	Charge Pump Kit (Includes Items 41,42,46,59,60,61)	1	
	2900827	Cylinder Block Kit (Includes Items 19-28,40,50,53,55,58)	1	

**SECTION 2 TURNTABLE**

# SECTION 2 TURNTABLE

FIGURE 2-15. PUMP ASSEMBLY - HYDRO-AIR

SECTION 2 TURNTABLE

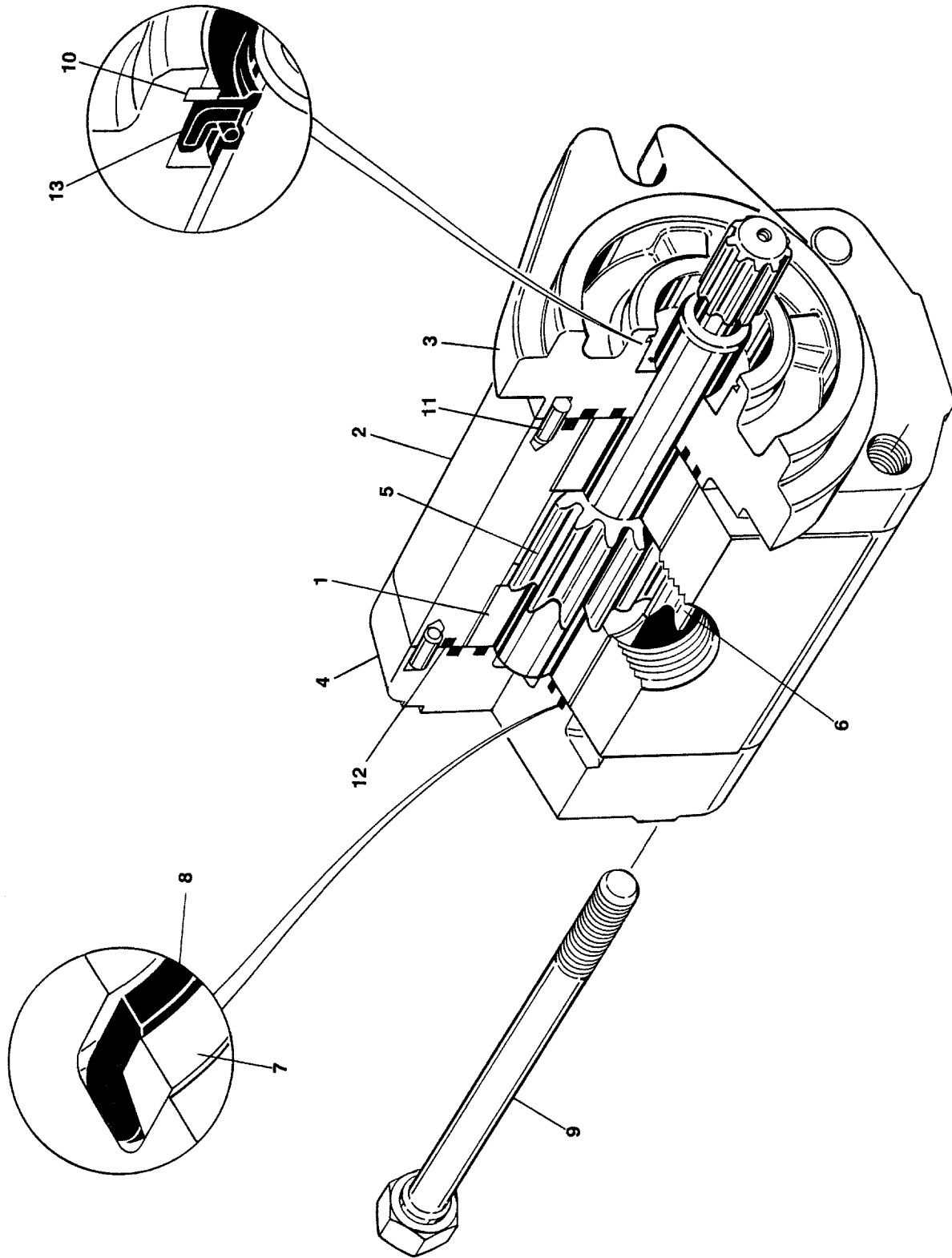

# SECTION 2 TURNTABLE

**FIGURE 2-15. PUMP ASSEMBLY - HYDRO-AIR**

FIG & ITEM #	PART NUMBER	DESCRIPTION	QTY.	REV.
	3600286	<b>PUMP ASSEMBLY - HYDRO-AIR</b>	Ref.	—
1	7010105	Bearing/Bushing	2	
2	Not Serviced	Housing	1	
3	Not Serviced	Flange, Mounting	1	
4	7010103	Cover, End	1	
5	7010126	Gear, Drive	1	
6	7010125	Gear, Idler	1	
7	Kit	Ring, Anti-Extrusion	2	
8	Kit	Seal	2	
9	7010124	Bolt	4	
10	7010104	Ring, Retaining	1	
11	7010127	Pin, Dowel	4	
12	Kit	Seal, O-Ring	2	
13	Kit	Seal, Shaft	1	
		-----		
	7007489	Seal Kit (Includes Items 7,8,12 and 13)	1	

SECTION 2 TURNTABLE

# SECTION 2 TURNTABLE

FIGURE 2-16. TANKS INSTALLATION

SECTION 2 TURNTABLE

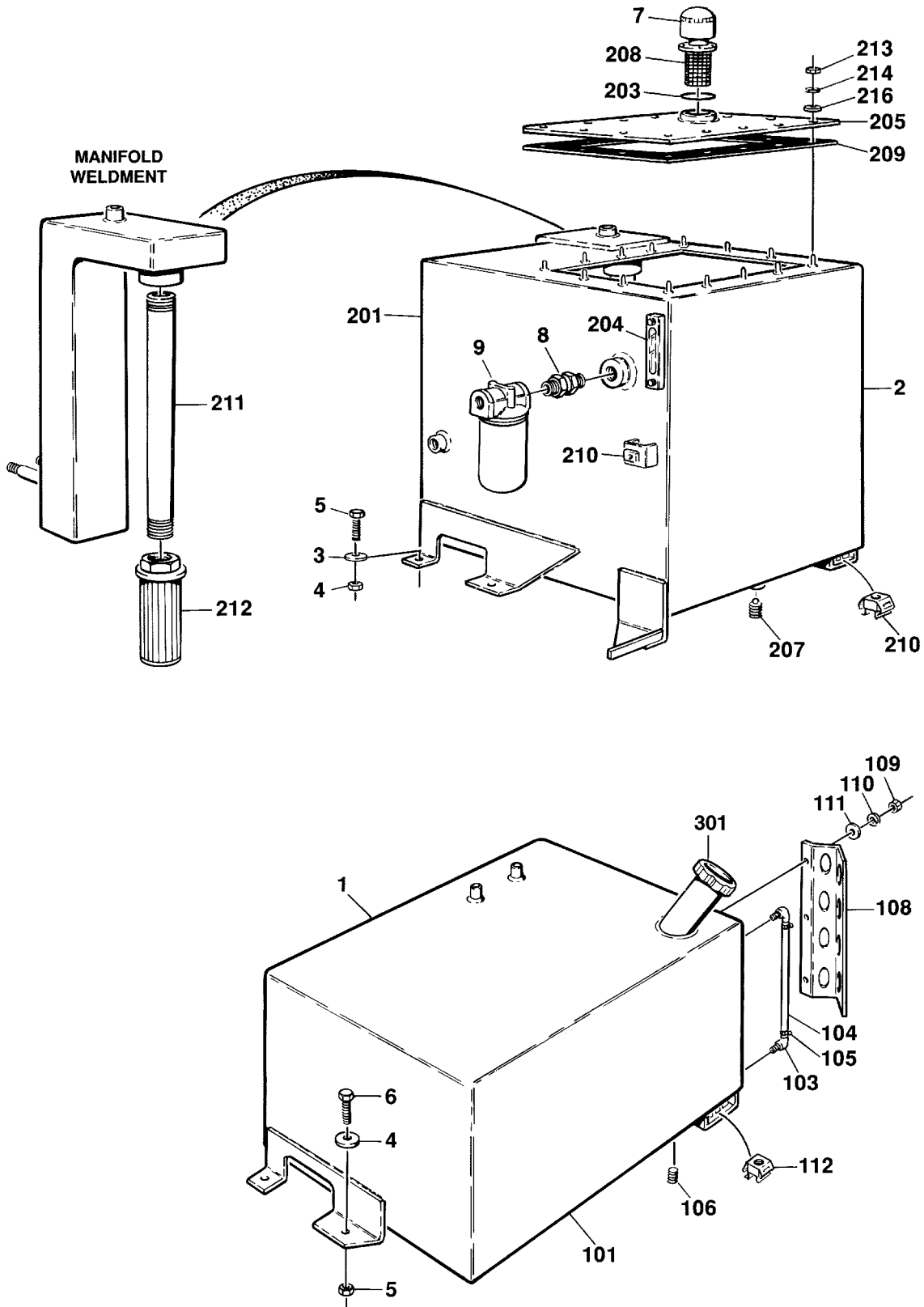



# SECTION 2 TURNTABLE

**FIGURE 2-16. TANKS INSTALLATION**

FIG & ITEM #	PART NUMBER	DESCRIPTION	QTY.	REV.
	0252524	<b>TANKS INSTALLATION</b>	Ref.	5
1	4400386	Fuel Tank Assembly (See Items 101-112 for Breakdown)	1	
2		Hydraulic Oil Tank Assembly Options: (See Items 201-216 for Breakdown)		
	4400340	Standard Tank	1	
	4400444	Tank w/ Welder	1	
3	0641614	Bolt 3/8"-16NC x 1 3/4"	4	
4	4711600	Flatwasher 3/8"	15	
5	3311605	Locknut 3/8"-16NC	8	
6	0641616	Bolt 3/8"-16NC x 2"	3	
7	1340046	Breather	1	
8	2220893	Fitting	1	
9	2120134	Filter, Hydraulic	1	
	2120129	Element	1	
	4300034	Stud, Weld	4	
	4400386	<b>FUEL TANK ASSEMBLY</b>	Ref.	2
101	4400387	Tank Weldment	1	
102	Not Used			
103	2180467	Fitting, 90°	2	
104	4562516	Tube, Sight	15 in./38cm	
105	1320022	Clamp	2	
106	2200052	Plug, Pipe - 1/4"	1	
107	0100020	Sealant, Thread (Not Shown)	A/R	
108	4060574	Protector, Gage	1	
109	3311401	Nut 1/4"-20NC	3	
110	4761400	Lockwasher 1/4"	3	
111	4751400	Flatwasher 1/4"	3	
112	3300205	Nut, Retainer 5/16"-18NC	3	
	4400340	<b>HYDRAULIC OIL TANK ASSEMBLY</b>	Ref.	B
201	4400341	Tank Weldment	1	
202	Not Used			
203	4740338	Washer, Sealing	6	
204	2420080	Gage, Level	1	
	7016664	Washer, Sealing	2	
205	1670625	Lid	1	
206	Not Used			
207	3520022	Plug, Magnetic	1	
208	1340045	Basket, Strainer	1	
209	3960371	Gasket	1	
210	3300205	Nut, Retainer 5/16"-18NC	3	
211	2180606	Nipple, Pipe	1	
212	2120104	Filter	1	

SECTION 2 TURNTABLE

# SECTION 2 TURNTABLE

**FIGURE 2-16. TANKS INSTALLATION (CONTINUED)**

FIG & ITEM #	PART NUMBER	DESCRIPTION	QTY.	REV.
213	3311401	Nut 1/4"-20NC	14	
214	4761400	Lockwasher 1/4"	14	
215	0100020	Sealant, Thread (Not Shown)	A/R	
216	4751400	Flatwasher 1/4"	14	
		<b>FUEL CAP ASSEMBLY OPTIONS:</b>	Ref.	
	0257365	<b>STANDARD</b>	Ref.	1
	0257366	<b>"RED" - PROTECTOSEAL</b>	Ref.	2
	0258626	<b>"BLUE" - PROTECTOSEAL</b>	Ref.	1
301		Cap, Fill Options:	1	
	1120314	Cap, Fill - Standard		
	1120367	Cap, Fill - "Red" Protectoseal		
	1120512	Cap, Fill - "Blue" Protectoseal		

**SECTION 2 TURNTABLE**

# SECTION 2 TURNTABLE

FIGURE 2-16. TANKS INSTALLATION (CONTINUED)

FIG & ITEM #	PART NUMBER	DESCRIPTION	QTY.	REV.

**S  
E  
C  
T  
I  
O  
N  
  
2  
  
T  
U  
R  
N  
T  
A  
B  
L  
E**

# SECTION 2 TURNTABLE

FIGURE 2-17. HOOD INSTALLATION (PRIOR TO S/N 55762)

SECTION 2 TURNTABLE



# SECTION 2 TURNTABLE

**FIGURE 2-17. HOOD INSTALLATION (PRIOR TO S/N 55762)**

FIG & ITEM #	PART NUMBER	DESCRIPTION	QTY.	REV.
	0253362	<b>HOOD INSTALLATION - NOISE REDUCTION</b> <b>Note: Replacement decals must be ordered separately - See Section 8.</b>	Ref.	5
1	3536417	Panel - Hood Top (Engine Side) Options:	1	
2	4844390	Panel - Hood Top (Valve Side) Options:	1	
3	3380419	Panel - Hood (Valve Side) Options:	1	
4	3380400	Panel - Hood (Engine Side)	1	
5	4844087	Panel - Door (Engine Side)	1	
6	1780172	Door (Valve Side)	1	
7	4844236	Duct, Discharge (Engine Side)	1	
8	3535948	Plate, Baffle (Engine Side)	1	
9	2940051	Latch	1	
10	4844113	Door (Valve Side)	1	
11	3380379	Panel - Hood Top (Valve Side)	1	
12	4844074	Door (Engine Side)	1	
13	Not Used			
14	4843334	Mounting, Gas Spring	1	
15	3941405	Screw, Self-Tap 1/4" x 5/8"	8	
16	4761400	Lockwasher 1/4"	8	
17	4300034	Stud (Welded on Part)	16	
18	4751600	Flatwasher 3/8"	16	
19	3311605	Locknut 3/8"-16NC	16	
20	4160081	Spring, Gas	2	
21	0630383	Bolt, Carriage 5/16"-18NC x 3/4"	4	
22	4751500	Flatwasher 5/16"	10	
23	3311505	Locknut 5/16"-18NC	6	
24	0641406	Bolt 1/4"-20NC x 3/4"	40	
25	3311405	Locknut 1/4"-20NC	70	
26	4751400	Flatwasher 1/4"	48	
27	0901500	Bracket, Mounting - Hood	1	
28	4843324	Bracket, Mounting - Hood	1	
29	0901502	Bracket, Mounting - Hood	3	
30	Not Used			
31	1670516	Cover, Front	1	
32	4844083	Hood (Front)	1	
33	4740362	Washer, Fender	41	
34	0641408	Bolt 1/4"-20NC x 1"	22	
35	3537819	Plate, Extension - Base	1	
36	0641512	Bolt 5/16"-18NC x 1 1/2"	5	
37	0940036	Bumper, Door	2	
38	0901197	Bracket, Door Stop	2	
39	Not Used			
40	0641508	Bolt 5/16"-18NC x 1"	4	
41	4761500	Lockwasher 5/16"	4	
42	3200222	Mounting, Gas Spring	2	
43	2940042	Mounting, Latch	5	
44	Not Used			
45	Not Used			

**SECTION 2 TURNTABLE**

# SECTION 2 TURNTABLE

**FIGURE 2-17. HOOD INSTALLATION (PRIOR TO S/N 55762) (CONTINUED)**

FIG & ITEM #	PART NUMBER	DESCRIPTION	QTY.	REV.
46	4300032	Stud (Welded on Part)	5	
47	3536414	Plate, Seal	1	
48	3536415	Plate, Seal	1	
49	3535951	Plate, Hinge Shield	1	
50	3820018	Rivet	10	
51	2820059	Acoustical Foam - 33 x 20	1	
52	2820058	Acoustical Foam - 20 x 17	1	
53	2820053	Acoustical Foam - 6 3/4" x 14 3/4"	1	
54	2820057	Acoustical Foam - 24" x 16 3/4"	1	
55	4060803	Shield, Flex Trim (Not Shown Located on Turntable)	2ft/0.6m	
		-----		
	0100011	Loctite #242	A/R	
	0252652	<b>HOOD SEALS INSTALLATION</b>	Ref.	A
101	3960418	Seal	13 ft./4m	
102	3960389	Seal, Door	8 ft./2.4m	
103	3960429	Tape, Sealant	7 ft./2.1m	
104	3960433	Seal	6 ft./1.8m	
	0251543	<b>ALARM INSTALLATION (OPTIONAL)</b>	Ref.	2
201	0140032	Alarm	1	
202	0641406	Bolt 1/4"-20NC x 3/4"	2	
203	4751400	Flatwasher 1/4"	4	
204	3311405	Locknut 1/4"-20NC	2	

**SECTION 2 TURNTABLE**

# SECTION 2 TURNTABLE

FIGURE 2-17. HOOD INSTALLATION (PRIOR TO S/N 55762) (CONTINUED)

FIG & ITEM #	PART NUMBER	DESCRIPTION	QTY.	REV.

**S  
E  
C  
T  
I  
O  
N  
  
2  
  
T  
U  
R  
N  
T  
A  
B  
L  
E**

# SECTION 2 TURNTABLE

FIGURE 2-18. HOOD INSTALLATION (S/N 55762 TO PRESENT)

SECTION 2 TURNTABLE

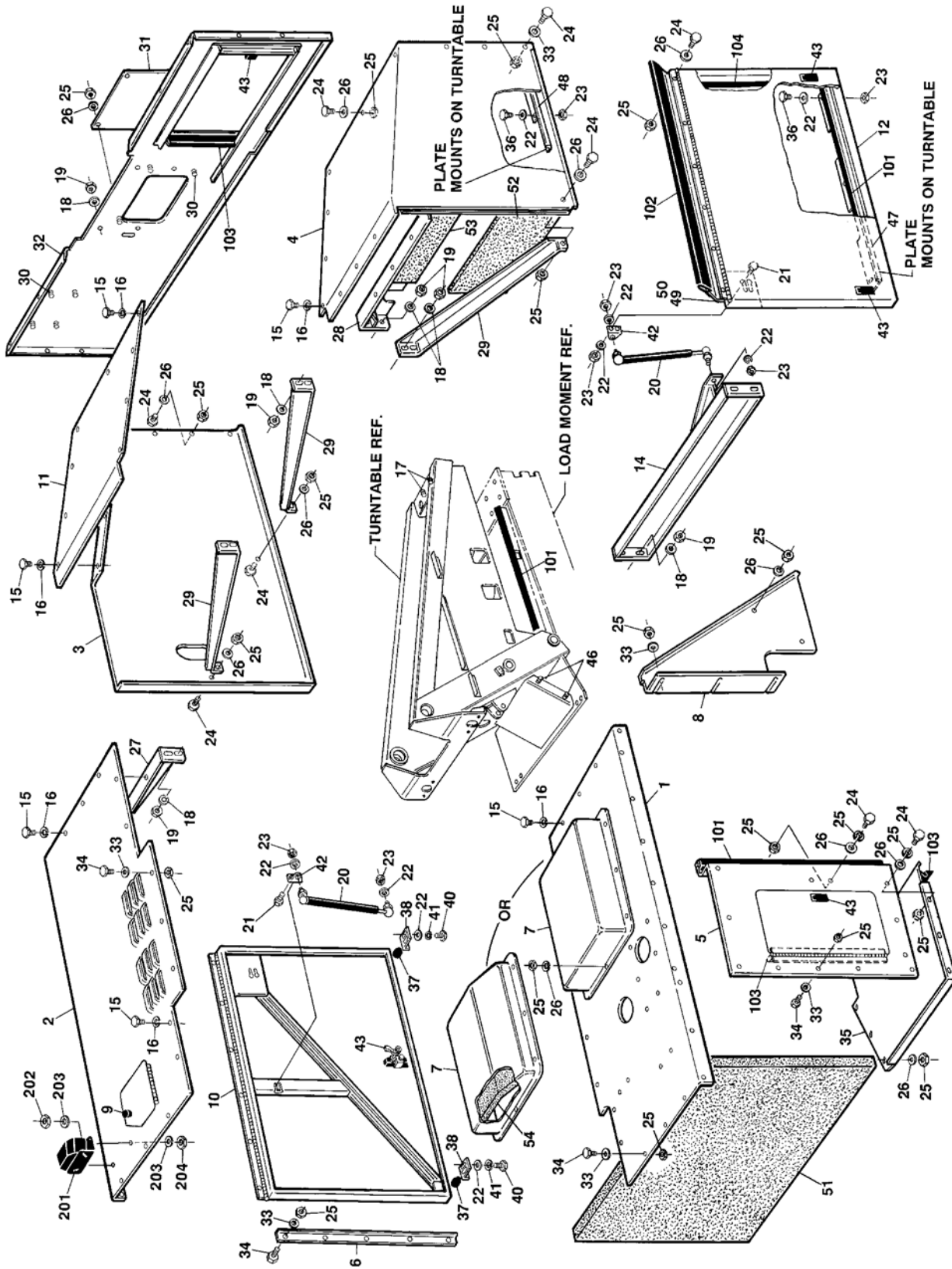



# SECTION 2 TURNTABLE

**FIGURE 2-18. HOOD INSTALLATION (S/N 55762 TO PRESENT)**

FIG & ITEM #	PART NUMBER	DESCRIPTION	QTY.	REV.
	0270677	<b>HOOD INSTALLATION - NOISE REDUCTION</b> <b>Note: Replacement decals must be ordered separately - See Section 8.</b>	Ref.	1
1	3572552	Panel - Hood Top (Engine Side)	1	
2	4846311	Panel - Hood Top (Valve Side)	1	
3	3380455	Panel - Hood (Valve Side)	1	
4	3380456	Panel - Hood (Engine Side)	1	
5	4846312	Panel - Door (Engine Side)	1	
6	1780321	Door (Valve Side)	1	
7	4846313	Duct, Discharge (Engine Side)	1	
8	3535948	Plate, Baffle (Engine Side)	1	
9	2940051	Latch	1	
10	4846314	Door (Valve Side)	1	
11	3380457	Panel - Hood Top (Valve Side)	1	
12	4846315	Door (Engine Side)	1	
13	Not Used			
14	4843334	Mounting, Gas Spring	1	
15	3941405	Screw, Self-Tap 1/4" x 5/8"	8	
16	4761400	Lockwasher 1/4"	8	
17	4300034	Stud (Welded on Part)	16	
18	4751600	Flatwasher 3/8"	16	
19	3311605	Locknut 3/8"-16NC	16	
20	4160081	Spring, Gas	2	
21	0630383	Bolt, Carriage 5/16"-18NC x 3/4"	4	
22	4751500	Flatwasher 5/16"	10	
23	3311505	Locknut 5/16"-18NC	6	
24	0641406	Bolt 1/4"-20NC x 3/4"	40	
25	3311405	Locknut 1/4"-20NC	70	
26	4751400	Flatwasher 1/4"	48	
27	0901500	Bracket, Mounting - Hood	1	
28	4843324	Bracket, Mounting - Hood	1	
29	0901502	Bracket, Mounting - Hood	3	
30	Not Used			
31	1670975	Cover, Front	1	
32	4846316	Hood (Front)	1	
33	4740362	Washer, Fender	41	
34	0641408	Bolt 1/4"-20NC x 1"	22	
35	3537819	Plate, Extension - Base	1	
36	0641512	Bolt 5/16"-18NC x 1 1/2"	5	
37	0940036	Bumper, Door	2	
38	0901197	Bracket, Door Stop	2	
39	Not Used			
40	0641508	Bolt 5/16"-18NC x 1"	4	
41	4761500	Lockwasher 5/16"	4	
42	3200222	Mounting, Gas Spring	2	
43	2940042	Mounting, Latch	5	
44	Not Used			
45	Not Used			

**SECTION 2 TURNTABLE**

# SECTION 2 TURNTABLE

**FIGURE 2-18. HOOD INSTALLATION (S/N 55762 TO PRESENT) (CONTINUED)**

**SECTION 2 TURNTABLE**

FIG & ITEM #	PART NUMBER	DESCRIPTION	QTY.	REV.
46	4300032	Stud (Welded on Part)	5	
47	3536414	Plate, Seal	1	
48	3536415	Plate, Seal	1	
49	3535951	Plate, Hinge Shield	1	
50	3820018	Rivet	10	
51	2820059	Acoustical Foam - 33 x 20	1	
52	2820058	Acoustical Foam - 20 x 17	1	
53	2820053	Acoustical Foam - 6 3/4" x 14 3/4"	1	
54	2820057	Acoustical Foam - 24" x 16 3/4"	1	
55	4060803	Shield, Flex Trim (Not Shown Located on Turntable)	2ft/0.6m	
		-----		
	0100011	Loctite #242	A/R	
	0252652	<b>HOOD SEALS INSTALLATION</b>	Ref.	A
101	3960418	Seal	13 ft./4m	
102	3960389	Seal, Door	8 ft./2.4m	
103	3960429	Tape, Sealant	7 ft./2.1m	
104	3960433	Seal	6 ft./1.8m	
	0251543	<b>ALARM INSTALLATION (OPTIONAL)</b>	Ref.	2
201	0140032	Alarm	1	
202	0641406	Bolt 1/4"-20NC x 3/4"	2	
203	4751400	Flatwasher 1/4"	4	
204	3311405	Locknut 1/4"-20NC	2	

# SECTION 2 TURNTABLE

FIGURE 2-18. HOOD INSTALLATION (S/N 55762 TO PRESENT) (CONTINUED)

FIG & ITEM #	PART NUMBER	DESCRIPTION	QTY.	REV.

**S  
E  
C  
T  
I  
O  
N  
  
2  
  
T  
U  
R  
N  
T  
A  
B  
L  
E**

# SECTION 2 TURNTABLE

FIGURE 2-19. OIL COOLER INSTALLATION

SECTION 2 TURNTABLE

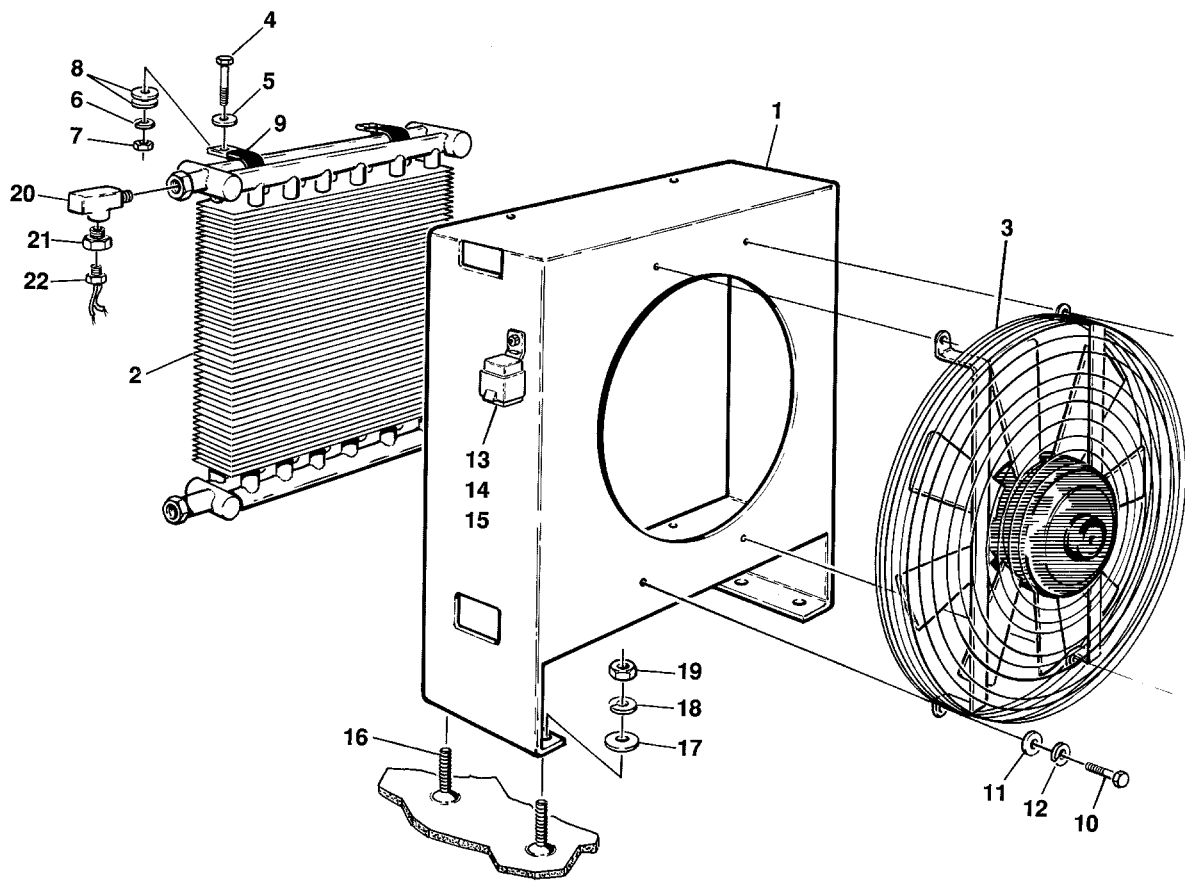

# SECTION 2 TURNTABLE

**FIGURE 2-19. OIL COOLER INSTALLATION**

FIG & ITEM #	PART NUMBER	DESCRIPTION	QTY.	REV.
	0252906	<b>OIL COOLER INSTALLATION (OPTIONAL)</b>	Ref.	3
1	4844177	Bracket, Oil Cooler	1	
2	3620003	Oil Cooler Assembly	1	
3	2060012	Fan, Oil Cooler	1	
4	0641508	Bolt 5/16"-18NC x 1"	4	
5	4751500	Flatwasher 5/16"	4	
6	4761500	Lockwasher 5/16"	4	
7	3311501	Nut 5/16"-18NC	4	
8	4751600	Flatwasher 3/8"	8	
9	1320060	Clamp	4	
10	0731006	Bolt #10-32NF x 3/4"	5	
11	4751000	Flatwasher #10	5	
12	4761000	Lockwasher #10	5	
13	3740080	Relay	1	
14	4460374	Plug	1	
15	4460375	Terminal	4	
16	4300048	Stud (Welded on Part)	4	
17	4751800	Flatwasher 1/2"	4	
18	4761800	Lockwasher 1/2"	4	
19	3311801	Nut 1/2"-13NC	4	
20	2220369	Fitting, Tee	1	
21	2220282	Fitting, Reducer	1	
22	4360181	Switch, Temperature	1	

SECTION 2 TURNTABLE

# SECTION 2 TURNTABLE

FIGURE 2-19. OIL COOLER INSTALLATION (CONTINUED)

FIG & ITEM #	PART NUMBER	DESCRIPTION	QTY.	REV.

**S  
E  
C  
T  
I  
O  
N  
  
2  
  
T  
U  
R  
N  
T  
A  
B  
L  
E**

# SECTION 3 BOOM

## TABLE OF CONTENTS

FIGURE	DESCRIPTION	PAGE
3-1	BOOM ASSEMBLY COMPONENTS .....	3-2
3-2	CHAIN ADJUSTER ASSEMBLIES .....	3-12
3-3	JIB BOOM INSTALLATION .....	3-16
3-4	EXTEND-A-REACH INSTALLATION .....	3-18
3-5	BOOM LENGTH INDICATOR AND LIMIT SWITCHES INSTALLATION .....	3-22
3-6	BOOM WIPERS INSTALLATION .....	3-26

# SECTION 3 BOOM

FIGURE 3-1. BOOM ASSEMBLY COMPONENTS INSTALLATION (SHEET 1 OF 2)

SECTION 3 BOOM

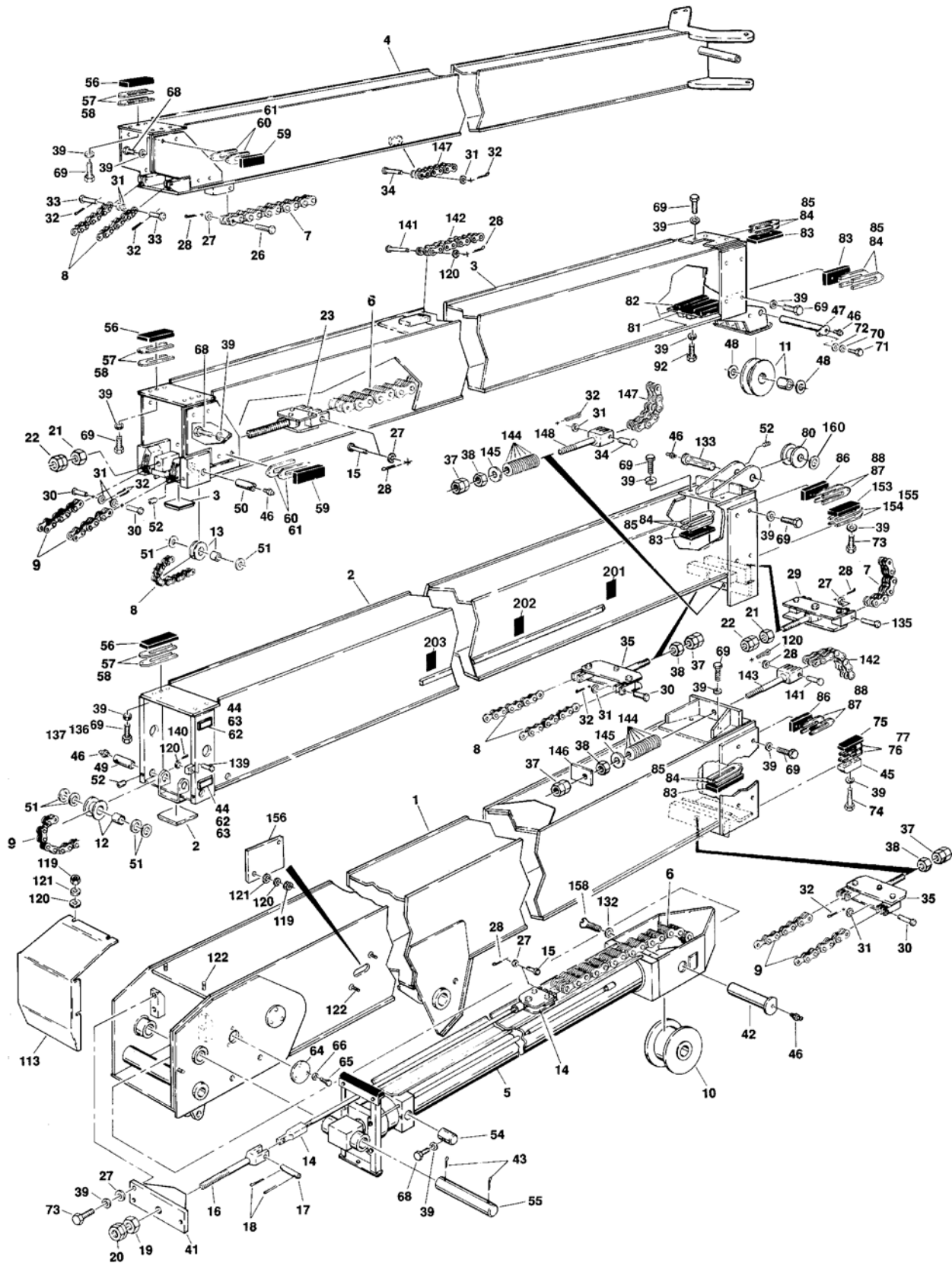



# SECTION 3 BOOM

FIGURE 3-1. BOOM ASSEMBLY COMPONENTS INSTALLATION (SHEET 2 OF 2)

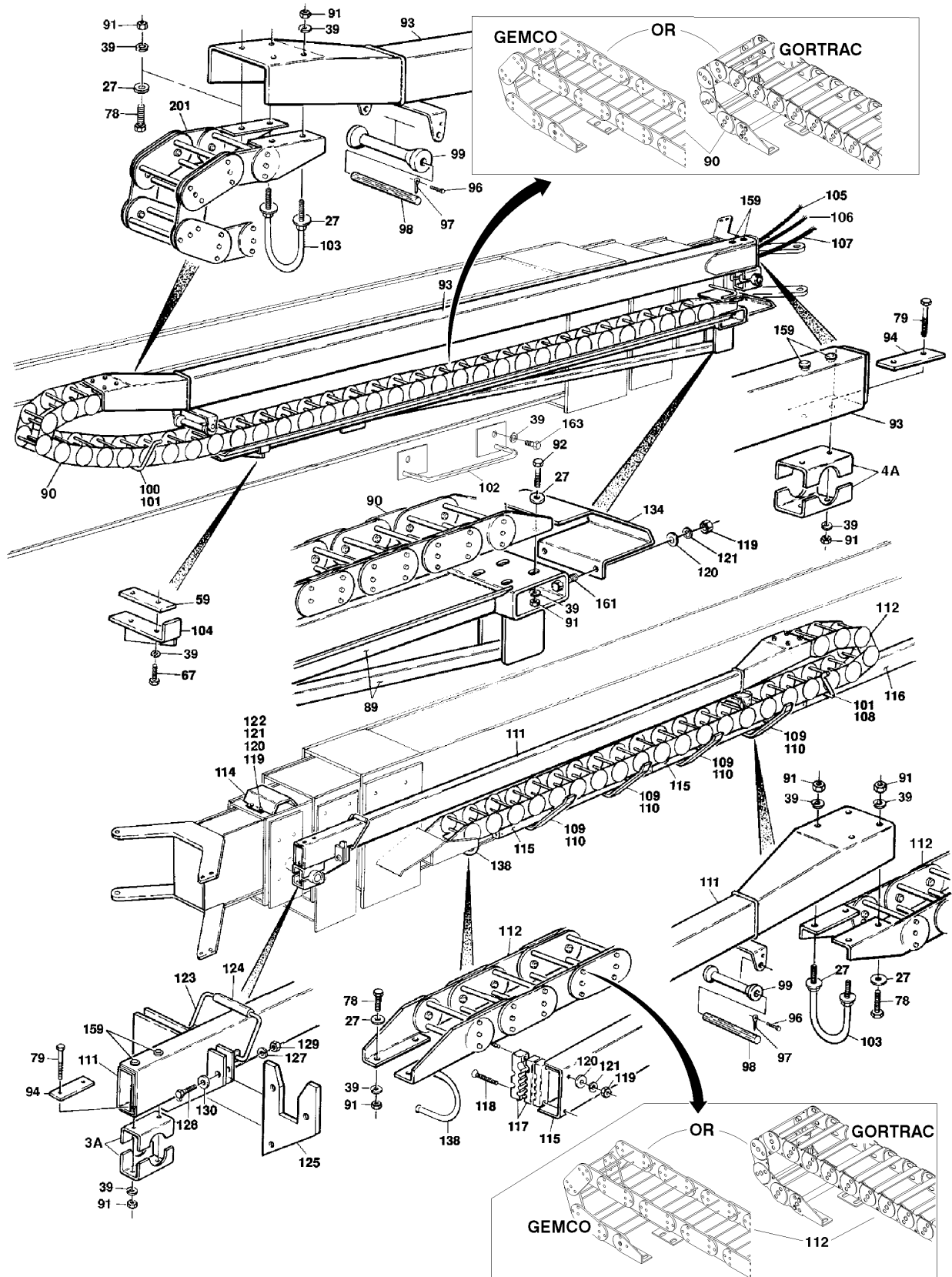

SECTION 3 BOOM

# SECTION 3 BOOM

**FIGURE 3-1. BOOM ASSEMBLY COMPONENTS INSTALLATION**

FIG & ITEM #	PART NUMBER	DESCRIPTION	QTY.	REV.
		<b>BOOM ASSEMBLY COMPONENTS INSTALLATION</b>	Ref.	
		<b>BOOM ASSEMBLIES</b>	Ref.	
	0801265	<b>100SX - CE SPEC</b>	Ref.	2
	0801231	<b>110SX - AUSTRALIAN SPEC</b>	Ref.	2
	0801241	<b>110SX - CE SPEC</b>	Ref.	2
	0801243	<b>110SX - WITH INVERTED POWER TRACK - AUSTRALIAN SPEC</b>	Ref.	3
	0801230	<b>110SXJ - AUSTRALIAN SPEC</b>	Ref.	2
	0801235	<b>110SXJ - CE SPEC</b>	Ref.	3
	0801236	<b>110SXJ - WITH INVERTED POWER TRACK - AUSTRALIAN SPEC</b>	Ref.	4
	0801232	<b>120SXJ - AUSTRALIAN SPEC</b>	Ref.	1
	0801240	<b>120SXJ - CE SPEC</b>	Ref.	2
	0801269	<b>120SXJ - W/LENGTH LIMIT - CE SPEC</b>	Ref.	2
1		Base Weldment Options:	1	
	0800802	100SX		7
	0800649	110SX		9
	0800603	110SXJ		9
	0800649	110SX/110SXJ - With Inverted Power Track		9
	0800765	120SXJ		7
	0801270	120SXJ - W/Length Limit		1
2		Inner Mid Weldment Options:	1	
	0800766	110SX/120SXJ		6
	0800785	100SX/110SXJ		6
	0800766	110SX/110SXJ - With Inverted Power Track		6
	3532549	Plate, Skid (Rear Bottom)	1	
	0801271	120SXJ - W/Length Limit		1
3		Outer Mid Weldment Options:	1	
	0800767	110SX/120SXJ		
	0800786	100SX/110SXJ		
	0800767	110SX/110SXJ - With Inverted Power Track		
	3532549	Plate, Skid (Rear Bottom)	1	
3A	1320121	Clamp	1	
4		Fly Weldment Options:	1	
	0800804	100SX		
	0800796	110SX		
	0800787	110SXJ		
	0800796	110SX/110SXJ - With Inverted Power Track		
	0801155	120SXJ		
4A	1320121	Clamp	1	
5		Telescope Cylinder Assembly Options: (See Section 5 for Breakdown)	1	
	1682820	110SX		
	1682821	100SX/110SXJ & 110SXJ - With Inverted Power Track		
	1682820	110SX - With Inverted Power Track		
	1683701	120SXJ		

**SECTION 3 BOOM**

# SECTION 3 BOOM

**FIGURE 3-1. BOOM ASSEMBLY COMPONENTS INSTALLATION (CONTINUED)**

FIG & ITEM #	PART NUMBER	DESCRIPTION	QTY.	REV.
6	1260239	Chain, Extend - Outer Mid BL866 Options: 100SX/110SXJ	1 set	
	1260235	110SX/120SXJ		
	1260235	110SX/110SXJ - With Inverted Power Track		
7	1260238	Chain, Extend - Fly BL823 Options: 100SX/110SXJ	1 set	
	1260234	110SX/120SXJ		
	1260234	110SX/110SXJ - With Inverted Power Track		
8	1260282	Chain, Retract - Fly BL446 Options: 100SX/110SXJ	1	
	1260275	110SX/120SXJ		
	1260275	110SX/110SXJ - With Inverted Power Track		
9	1260237	Chain, Retract - Outer Mid BL446 Options: 100SX/110SXJ	1	
	1260233	110SX/120SXJ		
	1260233	110SX/110SXJ - With Inverted Power Track		
10	3580139	Sheave - Outer Mid Extend Chain	1	
11	0238927	Sheave Assembly - Fly Extend Chain	A/R	B
	0961293	Bushing, Bronze (1 Per Sheave)	A/R	
12	0237151	Sheave Assembly - Outer Mid Extend Chain	2	B
	0961353	Bushing, Bronze (1 Per Sheave)	2	
13	0239606	Sheave Assembly - Fly Retract Chain	2	—
	0961369	Bushing, Bronze (1 Per Sheave)	2	
14		Adjustable Clevis Assembly - Outer Mid Retract Chain Options: (See Figure 3-2 for Breakdown)	1	
	0239267	100SX/110SXJ		
	0239268	110SX/120SXJ		
	0239268	110SX/110SXJ - With Inverted Power Track		
15	3421286	Pin, Attach	4	
16	1360171	Clevis	1	
17	3421279	Pin, Attach	1	
18	3450408	Pin, Cotter 1/8" x 2"	2	
19	3313002	Nut, Jam 1 1/4"-7NC	1	
20	3300244	Locknut, Nylon 1 1/4"-7NC Grade 8	1	
21	3312602	Nut, Jam 1"-8NC	2	
22	3300243	Locknut, Nylon 1"-8NC Grade 8	2	
23	0238901	Adjustable Clevis Assembly - Outer Mid Retract Chain (See Figure 3-2 for Breakdown)	1	
24	Not Used			
25	Not Used			
26	3421570	Pin, Attach	2	
27	4751600	Flatwasher 3/8"	35	
28	3450303	Pin, Cotter 3/22" x 3/4"	A/R	
29	0238919	Adjustable Clevis Assembly - Fly Extend Chain (See Figure 3-2 for Breakdown)	1	
30	3421280	Pin, Attach	6	
31	4751000	Flatwasher #10	A/R	
32	3450202	Pin, Cotter 1/16" x 1/2"	A/R	
33	3421629	Pin, Attach	2	
34	3420659	Pin, Attach (CE Machines Only)	2	

**SECTION 3 BOOM**

# SECTION 3 BOOM

**FIGURE 3-1. BOOM ASSEMBLY COMPONENTS INSTALLATION (CONTINUED)**

FIG & ITEM #	PART NUMBER	DESCRIPTION	QTY.	REV.
35	0238945	Adjustable Clevis Assembly - Outer Mid and Fly Retract Chain (See Figure 3-2 for Breakdown)	2	
36	Not Used			
37	3300240	Locknut, Nylon 5/8"-11NC (Grade 8)	A/R	
38	3312002	Nut, Jam 5/8"-11NC	A/R	
39	4761600	Lockwasher 3/8"	100	
40	Not Used			
41	4843105	Mount, End - Chain	1	
42	3421539	Pin, Sheave	1	
43	3450814	Pin, Cotter 1/4" x 3 1/2"	2	
44	4070616	Shim 1/32"/.8mm	4	
45	0560689	Block, Mounting - Wear Pad	2	
46	2160002	Fitting, Grease	A/R	
47		Pin, Sheave Options:	A/R	
	3421538	Australian	2	
	3421778	CE	1	
48	4740307	Washer, Thrust	A/R	
49	3421290	Pin, Sheave	2	
50	3422040	Pin, Sheave	2	
51	4740311	Washer, Thrust	12	
52	3951606	Setscrew 3/8"-16NC x 3/4"	A/R	
53	Not Used			
54	3421497	Pin, Trunion	2	
55	3421293	Pin, Cylinder	1	
56	3340475	Pad, Wear (Fly Rear Top, Inner Mid Rear Top and Outer Mid Rear Top)	6	
57	4070535	Shim 1/8"/3.2mm	A/R	
58	4070536	Shim 1/16"/1.6mm	A/R	
59	3340263	Pad, Wear (Carrier Support - Left Side, Fly Rear Sides and Outer Mid Rear Sides)	9	
60	4070544	Shim 1/16"/1.6mm	A/R	
61	4070545	Shim 1/8"/3.2mm	A/R	
62	3340563	Pad, Skid	4	
63	4070615	Shim 1/16"/1.6mm	A/R	
64	1120019	Cap	4	
65	0721003	Bolt #10-24NC x 3/8"	12	
66	4761000	Lockwasher #10	12	
67	0641605	Bolt 3/8"-16NC x 5/8"	2	
68	0641607	Bolt 3/8"-16NC x 7/8"	18	
69	0641609	Bolt 3/8"-16NC x 1 1/8"	52	
70	4761800	Lockwasher 1/2"	1	
71	0641808	Bolt 1/2"-13NC x 1"	1	
72	4751800	Flatwasher 1/2"	2	
73	0641614	Bolt 3/8"-16NC x 1 3/4"	7	
74	0641630	Bolt 3/8"-16NC x 3 3/4"	6	
75	3340496	Pad, Wear (Base Front Bottom)	2	
76	4070602	Shim 1/8"/3.2mm	2	
77	4070603	Shim 1/16"/1.6mm	2	
78	0641608	Bolt 3/8"-16NC x 1"	8	
79	0641636	Bolt 3/8"-16NC x 4 1/2"	4	

**SECTION 3 BOOM**

# SECTION 3 BOOM

**FIGURE 3-1. BOOM ASSEMBLY COMPONENTS INSTALLATION (CONTINUED)**

FIG & ITEM #	PART NUMBER	DESCRIPTION	QTY.	REV.
80	0239607	Sheave Assembly - Outer Mid Extend Chain	1	
	0961370	Bushing, Bronze	1	
81	0901700	Bracket, Wear Pad	1	
82	3340506	Pad, Wear (Outer Mid Front Bottom)	2	
83	3340500	Pad, Wear (Outer Mid Front Sides and Top, Inner Mid Front Top and Base Front Top)	10	
84	4070708	Shim 1/16"/1.6mm	A/R	
85	4070709	Shim 1/8"/3.2mm	A/R	
86	3340502	Pad, Wear (Inner Mid Front Sides and Base Front Sides)	8	
87	4070710	Shim 1/16"/1.6mm	8	
88	4070711	Shim 1/8"/3.2mm	8	
89	4844126	Tube, Hose and Cable (Left Side)	1	
90		Carrier Without Covers (Left Side) Options:	1	
	Use 1001119696	Carrier Without Covers (Left Side) - 100SX/110SX/120SXJ (was p/n 1180286)	1	
		Gemco Replacement Parts:		
	7006193	Repair Section - 1 Foot	A/R	
	7006133	Feet, Mounting (1 Pair)	2	
	7006138	Pin Kit	A/R	
		Gortrac Replacement Parts:		
	70003143	Repair Section - 1 Foot	A/R	
	70003144	Feet, Mounting (1 Pair)	2	
	1180292	Carrier Without Covers (Left Side) - 110SXJ	1	
	7006193	Repair Section - 1 Foot	A/R	
	7006133	Feet, Mounting (1 Pair)	2	
	7006138	Pin Kit	A/R	
	1180334	Carrier With Covers (Left Side) - 110SX/110SXJ - With Inverted Power Track	1	
	7006503	Repair Section - 1 Foot	A/R	
	7006133	Feet, Mounting (1 Pair)	2	
	7006138	Pin Kit	A/R	
91	3311601	Nut 3/8"-16NC	20	
92	0641610	Bolt 3/8"-16NC x 1 1/4"	6	
93		Carrier Tube Weldment (Left Side) Options:	1	
	1180297	100SX/110SX		
	1180293	110SXJ		
	1180297	110SX/110SXJ - With Inverted Power Track		
	1180287	120SXJ		
94	4280242	Strip, Reinforcing	2	
95	Not Used			
96	0641404	Bolt 1/4"-20NC x 1/2"	2	
97	3450806	Pin, Cotter 1/4" x 1 1/2"	2	
98	3841013	Rod, Roller	2	
99	3860050	Roller	2	
100	3840956	Hanger (Left Side)	1	
101	2660042	Holder	1	
102	0902470	Rod, Hose Retainer (Left Side)	1	
103	1320155	Clamp, U-Bolt	2	
104	4843080	Bracket, Support - Carrier Wear Pad (Left Side)	1	

# SECTION 3 BOOM

**FIGURE 3-1. BOOM ASSEMBLY COMPONENTS INSTALLATION (CONTINUED)**

FIG & ITEM #	PART NUMBER	DESCRIPTION	QTY.	REV.
105		Cable, Electrical - 10/4 + 18/16 Options:	1	
	4922403	100SX		
	4922401	110SX/110SXJ - With Inverted Power Track		
	4922402	120SXJ		
106		Cable, Electrical 10/3 Options:		
	1060393	Cable, Electrical 10/3 - Australian Spec	A/R	
		110SX/110SXJ - With Inverted Power Track	131 ft./40m	
		110SXJ	128 ft./39m	
		120SXJ	149 ft./45m	
	1060393	Cable, Electrical 10/3 - CE Spec	A/R	
		100SX	131 ft./40m	
	1060545	Cable, Electrical 10/3 - CE Spec	A/R	
		110SX/110SXJ - With Inverted Power Track	131 ft./40m	
		110SXJ	128 ft./39m	
		120SXJ	149 ft./45m	
107		Cable, Electrical - 16/30	1	
	4922406	100SX		
	4922404	110SX/110SXJ - With Inverted Power Track		
	4922405	120SXJ		
	4922406	120SXJ - W/Length Limit		
108		Cable, Electrical 16/4 Options:	50 ft./15m	
	1060079	110SXJ/110SXJ - With Inverted Power Track (Prior to S/N 60361 Only)		
	Not Required	100SX/110SX/110SX - With Inverted Power Track		
109	Not Used			
110	Not Used			
111	1180254	Carrier Tube Weldment (Right Side)	1	
112		Carrier (Right Side) Options:	1	
	1180236	Carrier Without Covers (Right Side) - 100SX/ 110SX/110SXJ/120SXJ	1	
	7006153	Repair Section - 1 Foot	A/R	
	7006133	Feet, Mounting (1 Pair)	2	
	7006138	Pin Kit	A/R	
	Use 1001119697	Carrier Without Covers (Right Side) - 110SX/ 110SXJ - With Inverted Power Track (was p/n 1180289)	1	
		Gemco Replacement Parts:		
	7016503	Repair Section - 1 Foot	A/R	
	7006133	Feet, Mounting (1 Pair)	2	
	7006138	Pin Kit	A/R	
		Gortrac Replacement Parts:		
	70003145	Repair Section - 1 Foot	A/R	
	70003146	Feet, Mounting (1 Pair)	2	
113		Cover, Boom End Options:	1	
	4843107	100SX/110SX		
	4843087	110SXJ		
	4843107	110SX/110SXJ - With Inverted Power Track		
	4843087	120SXJ		
114	3532793	Plate, Hose Cover	1	
115	4060685	Shield, Hose and Cable (Right Side)	2	

**SECTION 3 BOOM**

# SECTION 3 BOOM

**FIGURE 3-1. BOOM ASSEMBLY COMPONENTS INSTALLATION (CONTINUED)**

FIG & ITEM #	PART NUMBER	DESCRIPTION	QTY.	REV.
116	4060684	Shield, Hose and Cable (Right Side)	1	
117		Support, Hydraulic Line Options:	4	
	1320279	100SX/110SX/110SXJ/120SXJ		
	4340413	110SX - With Inverted Power Track		
	1320279	110SXJ - With Inverted Power Track		
118	4300098	Stud (Welded on Part)	8	
119	3311401	Nut 1/4"-20NC	A/R	
120	4751400	Flatwasher 1/4"	A/R	
121	4761400	Lockwasher 1/4"	A/R	
122	4300032	Stud (Welded on Part)	A/R	
123	3840858	Rod, Tube Retainer	1	
124	4562516	Tube	1	
125	4340453	Support, Bracket	1	
126	Not Used			
127	4761500	Lockwasher 5/16"	3	
128	0641510	Bolt 5/16"-18NC x 1 1/4"	3	
129	3311501	Nut 5/16"-18NC	3	
130	4751500	Flatwasher 5/16"	6	
131	Not Used			
132	4740349	Washer, Special	1	
133	3421632	Pin (CE Spec Machines Only)	1	
134	3536001	Plate, Ramp (Left Side)	1	
135	3421571	Pin, Attach	2	
136	Not Used			
137	Not Used			
138	Not Used			
139	3430408	Pin, Clevis 1/4" x 1"	1	
140	3450203	Pin, Cotter 1/16" x 3/4"	1	
141	3421628	Pin (CE Spec Machines Only)	2	
142	1260254	Chain (CE Spec Machines Only)	1	
143	1360234	Clevis (CE Spec Machines Only)	1	
144	4160098	Washer, Belleville (CE Spec Machines Only)	104	
145	4712000	Washer, Narrow (CE Spec Machines Only)	2	
146	0361727	Bar (CE Spec Machines Only)	1	
147	1260261	Chain, BL434 (CE Spec Machines Only)	1	
148	1360223	Clevis (CE Spec Machines Only)	1	
149		Cable 16/3 Options:	50ft/15m	
	Not Required	110SX/110SX - With Inverted Power Track		
	1060016	100SX/110SXJ/120SXJ		
	1060016	110SXJ - With Inverted Power Track		
150 to 151	Not Used			
152		Fitting, Grease Options:	2	
	Not Required	100SX		
	Not Required	110SX/110SX - With Inverted Power Track		
	2160001	110SX/110SXJ/120SXJ		
	Not Required	120SXJ W/Length Limit		
153	3340494	Pad, Wear (Inner Mid Front Bottom)	2	
154	4070600	Shim 1/8"/3.2mm	2	
155	4070601	Shim 1/16"/1.6mm	2	

# SECTION 3 BOOM

**FIGURE 3-1. BOOM ASSEMBLY COMPONENTS INSTALLATION (CONTINUED)**

FIG & ITEM #	PART NUMBER	DESCRIPTION	QTY.	REV.
156	Not Required			
157	Not Used			
158	0741608	Screw, Countersunk 3/8"-16NC x 1"	1	
159	Not Used			
160	4740304	Washer, Spacer (CE Spec Machines Only)	2	
161	0641407	Bolt 1/4" - 20 NC x 7/8"	2	
162	1670836	Cover (Not Shown) Located on Bottom of Boom Sections)	8	
163	0641611	Bolt 3/8"-16NC x 1 3/8"	2	
	0100011	----- Loctite #242	A/R	
		<b>RADIUS LIMIT TAPE INSTALLATIONS</b>	Ref.	
	0258596/1282060	<b>100SX - 50' Reach (CE)</b>	Ref.	1/F
	0252764/1282060	<b>110SX - 55' Reach (CE)</b>	Ref.	3/F
	0239878/1282060	<b>110SX - 60' Reach (AUSTRALIAN)</b>	Ref.	3/F
	0251100/1282060	<b>110SXJ - 55' &amp; 60' Reach (AUSTRALIAN &amp; CE)</b>	Ref.	4/F
	0252764/1282060	<b>120SXJ - 55' &amp; 60' Reach (AUSTRALIAN &amp; CE)</b>	Ref.	3/F
201		Tape Options:	6 in./15.3cm	
	4420016	Tape - Yellow (110SX - 60' Reach)		
	4420018	Tape - Blue (110SXJ - 55' & 60' Reach)		
	Not Required	100SX - 50' Reach		
	Not Required	110SX - 55' Reach		
	Not Required	120SX - 55' & 60' Reach		
202	4420017	Tape - Red	6 in./15.3cm	
203	4420015	Tape - White	6 in./15.3cm	

**SECTION 3 BOOM**



# SECTION 3 BOOM

FIGURE 3-1. BOOM ASSEMBLY COMPONENTS INSTALLATION (CONTINUED)

FIG & ITEM #	PART NUMBER	DESCRIPTION	QTY.	REV.

**S  
E  
C  
T  
I  
O  
N  
  
3  
  
B  
O  
O  
M**

# SECTION 3 BOOM

FIGURE 3-2. CHAIN ADJUSTER ASSEMBLIES

SECTION 3 BOOM

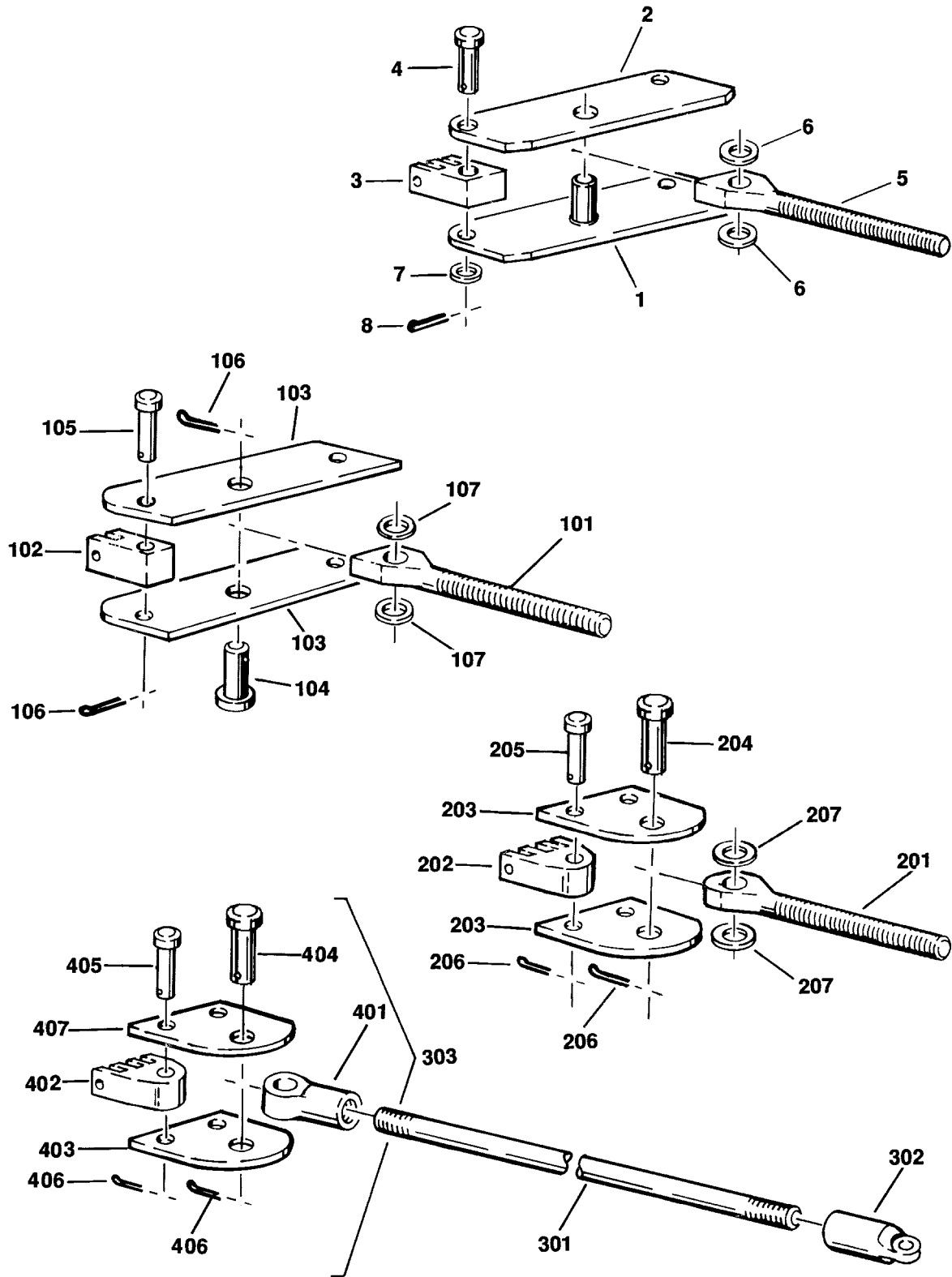

# SECTION 3 BOOM

**FIGURE 3-2. CHAIN ADJUSTER ASSEMBLIES**

FIG & ITEM #	PART NUMBER	DESCRIPTION	QTY.	REV.
		<b>CHAIN ADJUSTER ASSEMBLIES</b>	Ref.	
	0238945	<b>CHAIN ADJUSTER ASSEMBLY (OUTER MID AND FLY RETRACT)</b>	Ref.	—
1	4843026	Chain Plate Weldment	1	
2	3532466	Plate, Top	1	
3	1360175	Clevis	2	
4	3420552	Pin, Clevis	2	
5	0630197	Eyebolt	1	
6	4740156	Washer, Thrust	2	
7	4740270	Washer, Special	2	
8	3450504	Pin, Cotter 5/32" x 1"	2	
	0238919	<b>CHAIN ADJUSTER ASSEMBLY (FLY EXTEND)</b>	Ref.	—
101	0630410	Eyebolt	1	
102	1360209	Clevis	2	
103	3532425	Plate	2	
104	3421535	Pin, Adjuster Plate	1	
105	3421534	Pin, Clevis	2	
106	3450506	Pin, Cotter 3/32" x 1 1/2"	3	
107	4740111	Washer, Thrust	2	
	0238901	<b>CHAIN ADJUSTER ASSEMBLY (OUTER MID RETRACT)</b>	Ref.	—
201	0630409	Eyebolt	1	
202	1360206	Clevis	2	
203	3532410	Plate	2	
204	3421535	Pin, Adjuster Plate	1	
205	3421534	Pin, Clevis	2	
206	3450506	Pin, Cotter 3/32" x 1 1/2"	3	
207	4740111	Washer, Thrust	2	
	0239267	<b>CHAIN ADJUSTER AND ROD ASSEMBLY (OUTER MID RETRACT) (100SX)</b>	Ref.	B
	0239268	<b>CHAIN ADJUSTER AND ROD ASSEMBLY (OUTER MID RETRACT) (110SX/120SX)</b>	Ref.	3
301		Rod Options:	1	
	3840955	100SX		
	3840945	110SX/120SX (Production)		
	0273588	110SX/120SX (Post Production Alternative)		
	3841651	110SX/120SX (Post Production Alternative)		
302		Clevis, Rod Options:	1	
	1360208	Clevis, Rod (Production)		
	1360274	Clevis, Rod (Post Production Alternative)		
303	0238900	Chain Adjuster Assembly (See Items 401-407 for Breakdown)	1	

# SECTION 3 BOOM

**FIGURE 3-2. CHAIN ADJUSTER ASSEMBLIES (CONTINUED)**

FIG & ITEM #	PART NUMBER	DESCRIPTION	QTY.	REV.
	0100003	----- Loctite #277	A/R	
	0238900	<b>CHAIN ADJUSTER ASSEMBLY (OUTER MID RETRACT)</b>	Ref.	B
401	1360207	Clevis, Rod	1	
402	1360206	Clevis, Chain	2	
403	3532410	Plate, Chain Adjuster (Top)	1	
404	3421535	Pin, Adjuster Plate	1	
405	3421534	Pin, Clevis	2	
406	3450506	Pin, Cotter 3/32" x 1 1/2"	3	
407	3534436	Plate, Chain Adjuster Plate (Bottom)	1	

**SECTION 3 BOOM**

# SECTION 3 BOOM

FIGURE 3-2. CHAIN ADJUSTER ASSEMBLIES (CONTINUED)

FIG & ITEM #	PART NUMBER	DESCRIPTION	QTY.	REV.

**S  
E  
C  
T  
I  
O  
N  
  
3  
  
B  
O  
O  
M**

# SECTION 3 BOOM

FIGURE 3-3. JIB BOOM INSTALLATION

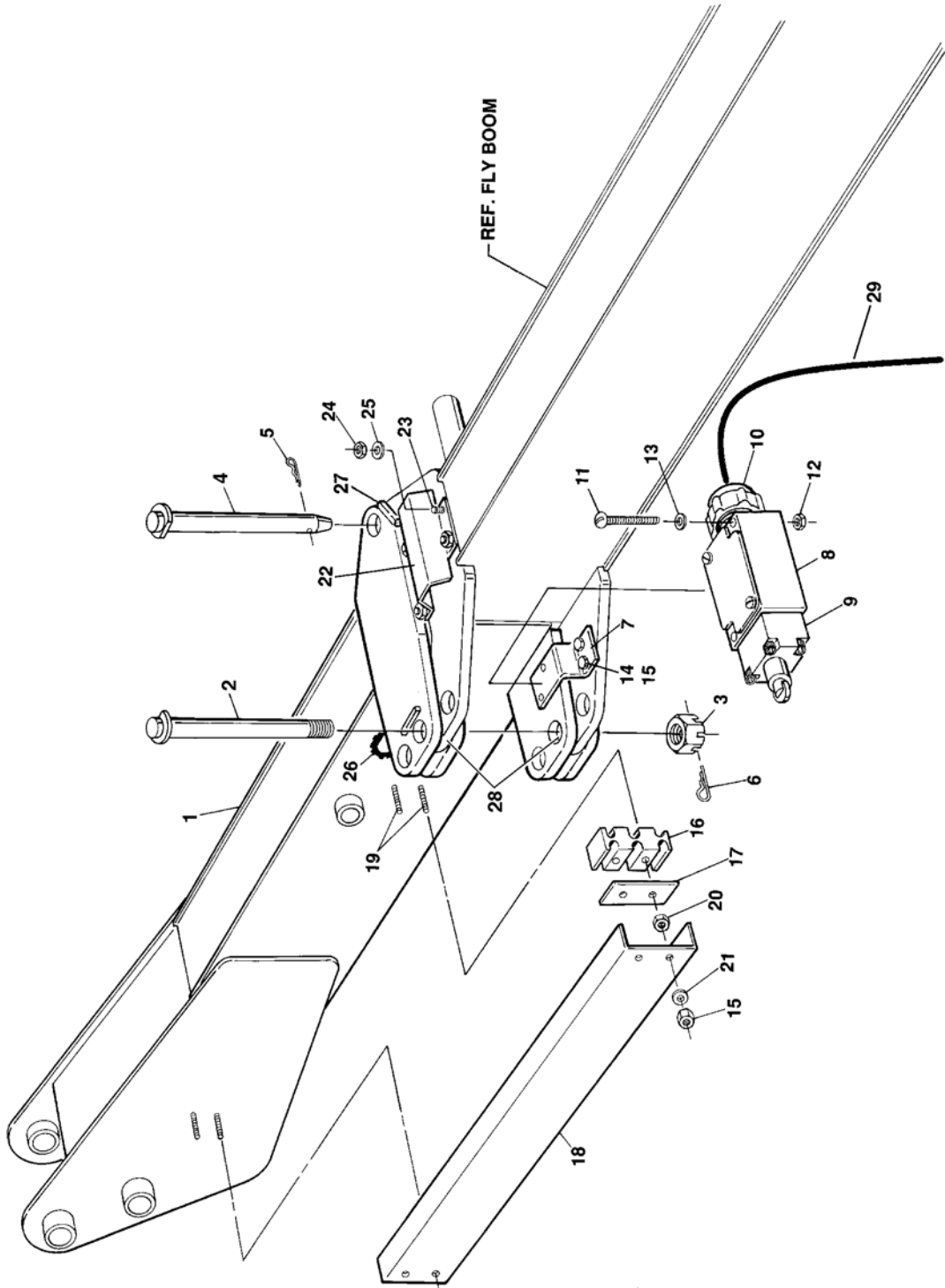

SECTION 3 BOOM

# SECTION 3 BOOM

**FIGURE 3-3. JIB BOOM INSTALLATION**

FIG & ITEM #	PART NUMBER	DESCRIPTION	QTY.	REV.
	0258414	<b>JIB BOOM INSTALLATION OPTIONS:</b>	Ref.	1
1	0801156	Boom, Jib	1	
2	3422727	Pin (Left Side Attach)	1	
3	3323403	Nut, Slotted 1 1/2" x 12NF	1	
4	3422679	Pin (Right Side Attach)	1	
5	3420592	Hairpin	1	
6	3451012	Pin, Cotter 5/16" x 3"	1	
7	0901835	Bracket, Limit Switch	1	
8	4360277	Switch, Limit	1	
9	4360307	Head, Switch	1	
10	4460049	Connector, Strain Relief	1	
11	0721016	Screw, Machine #10-24NC x 2"	2	
12	3311005	Locknut #10-24NC	2	
13	4751000	Flatwasher #10	2	
14	0641615	Bolt 3/8"-16NC x 1 7/8"	2	
15	3311605	Locknut	6	
16	1320184	Clamp, Hose and Cable	2	
17	3535978	Plate	2	
18	1670635	Cover, Hose and Cable	1	
19	4300076	Stud (Welded on Part)	4	
20	3311602	Nut, Jam 3/8"-16NC	4	
21	4751600	Flatwasher 3/8"	4	
22	3532793	Plate, Hose Cover	1	
23	4300032	Stud (Welded on Part)	4	
24	3311405	Locknut 1/4"-20NC	4	
25	4751400	Flatwasher 1/4"	4	
26	4060803	Trim, Flexible	10 in.	
27	2880814	Keystock (Welded on Part)	2	
28	0962181	Bushing, Garmax	2	
29	1060016	Cable 16/3 (S/N 60361 to Present)	50'	

**SECTION 3 BOOM**

# SECTION 3 BOOM

FIGURE 3-4. EXTEND-A-REACH INSTALLATION

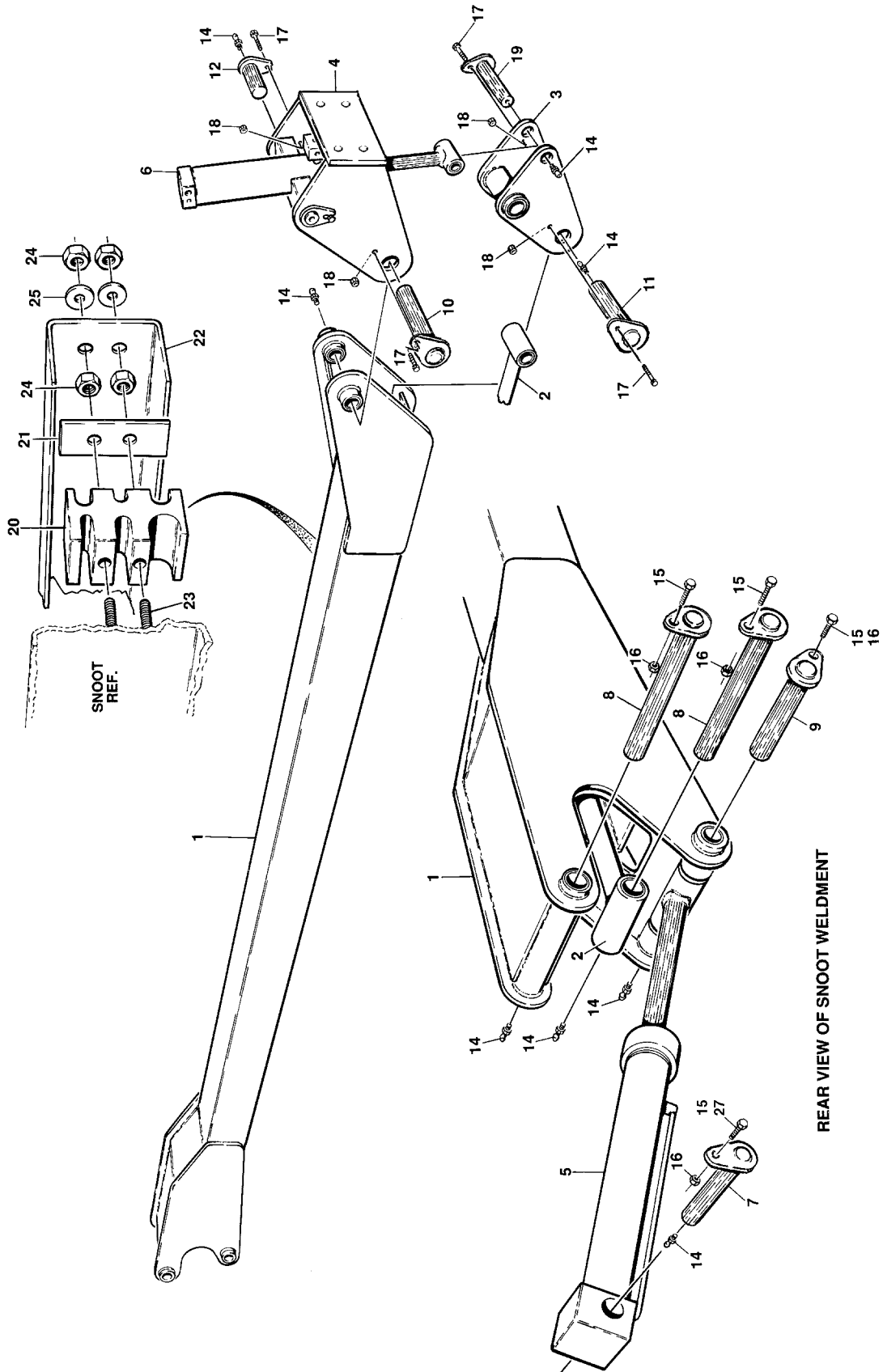

SECTION 3 BOOM



# SECTION 3 BOOM

**FIGURE 3-4. EXTEND-A-REACH INSTALLATION**

FIG & ITEM #	PART NUMBER	DESCRIPTION	QTY.	REV.
		<b>EXTEND-A-REACH INSTALLATIONS</b>	Ref.	
	0270286	<b>110SXJ</b>	Ref.	2
	0270287	<b>110SXJ (WITH INVERTED POWER TRACK) (AUSTRALIAN SPEC ONLY)</b>	Ref.	3
	0270288	<b>120SXJ</b>	Ref.	2
1		Snoot Weldment Options:	1	
	4844166	110SXJ		
	4844092	120SXJ		
	0960565	Bushing, Bronze	4	
2		Level Link Weldment Options:	1	
	4844167	110SXJ		
	4844093	120SXJ		
	0961654	Bushing, Bronze (Platform End)	2	
	0960565	Bushing, Bronze (Jib End)	2	
3	4844094	Level Plate Weldment	1	
	0961654	Bushing, Bronze	2	
4	4846193	Pivot Attach Weldment	1	
	1320051	Clamp, Hose	1	
5		Extend-A-Reach Lift Cylinder Assembly Options: (See Section 5 for Breakdown)	1	
	1683725	(Prior to S/N 64012)		
	1684164	(S/N 64012 to Present)		
6	1683530	Extend-A-Reach Level Cylinder Assembly (See Section 5 for Breakdown)	1	
7		Pin, Attach (Lift Cylinder - Barrel End) Options:	1	
	3422062	110SXJ		
	3422594	110SXJ - With Inverted Power Track (Prior to C# 140902)		
	3422891	110SXJ - With Inverted Power Track (C# 140902 to Present)		
	3422087	120SXJ		
8	3422077	Pin, Attach (Snoot and Level Link to Jib)	2	
9		Pin, Attach (Lift Cylinder - Rod End) Options:	1	
	3422079	110SXJ/120SXJ		
	3422166	110SXJ - With Inverted Power Track (Prior to C# 140902)		
	3422889	110SXJ - With Inverted Power Track (C# 140902 to Present)		
10	3422081	Pin, Attach (Snoot to Pivot)	1	
11	3422083	Pin, Attach (Level Link to Level Plate)	1	
12	3422037	Pin, Attach (Level Cylinder - Barrel End)	2	
13	Not Used			
14	2160002	Fitting, Grease	9	
15	0641608	Bolt 3/8"-16NC x 1"	A/R	
16	4761600	Lockwasher 3/8"	3	
17	0641610	Bolt 3/8"-16NC x 1 1/4"	6	
18	3311605	Locknut 3/8"-16NC	10	
19	3422085	Pin, Attach (Level Cylinder - Rod End)	1	
20	1320278	Clamp, Hose and Cable	2	

**SECTION 3 BOOM**

# SECTION 3 BOOM

**FIGURE 3-4. EXTEND-A-REACH INSTALLATION (CONTINUED)**

FIG & ITEM #	PART NUMBER	DESCRIPTION	QTY.	REV.
21	3535978	Plate	2	
22		Cover, Hose and Cable Options:	1	
	1670642	110SXJ		
	1670634	120SXJ		
23	4300076	Stud (Welded on Part)	4	
24	3311602	Nut, Jam 3/8"-16NC	4	
25	4751600	Flatwasher 3/8"	4	
26	Not Used			
27	0641606	Bolt 3/8"-16NC x 3/4" (110SX/110SXJ Only)	1	
28	4060803	Trim, Flexible (Not Shown) (110SX/110SXJ Only)	A/R	
		-----		
	0100011	Loctite #242	A/R	

**SECTION 3 BOOM**

# SECTION 3 BOOM

FIGURE 3-4. EXTEND-A-REACH INSTALLATION (CONTINUED)

FIG & ITEM #	PART NUMBER	DESCRIPTION	QTY.	REV.

**S  
E  
C  
T  
I  
O  
N  
  
3  
  
B  
O  
O  
M**

# SECTION 3 BOOM

FIGURE 3-5. BOOM LENGTH INDICATOR AND LIMIT SWITCHES INSTALLATION

SECTION 3 BOOM

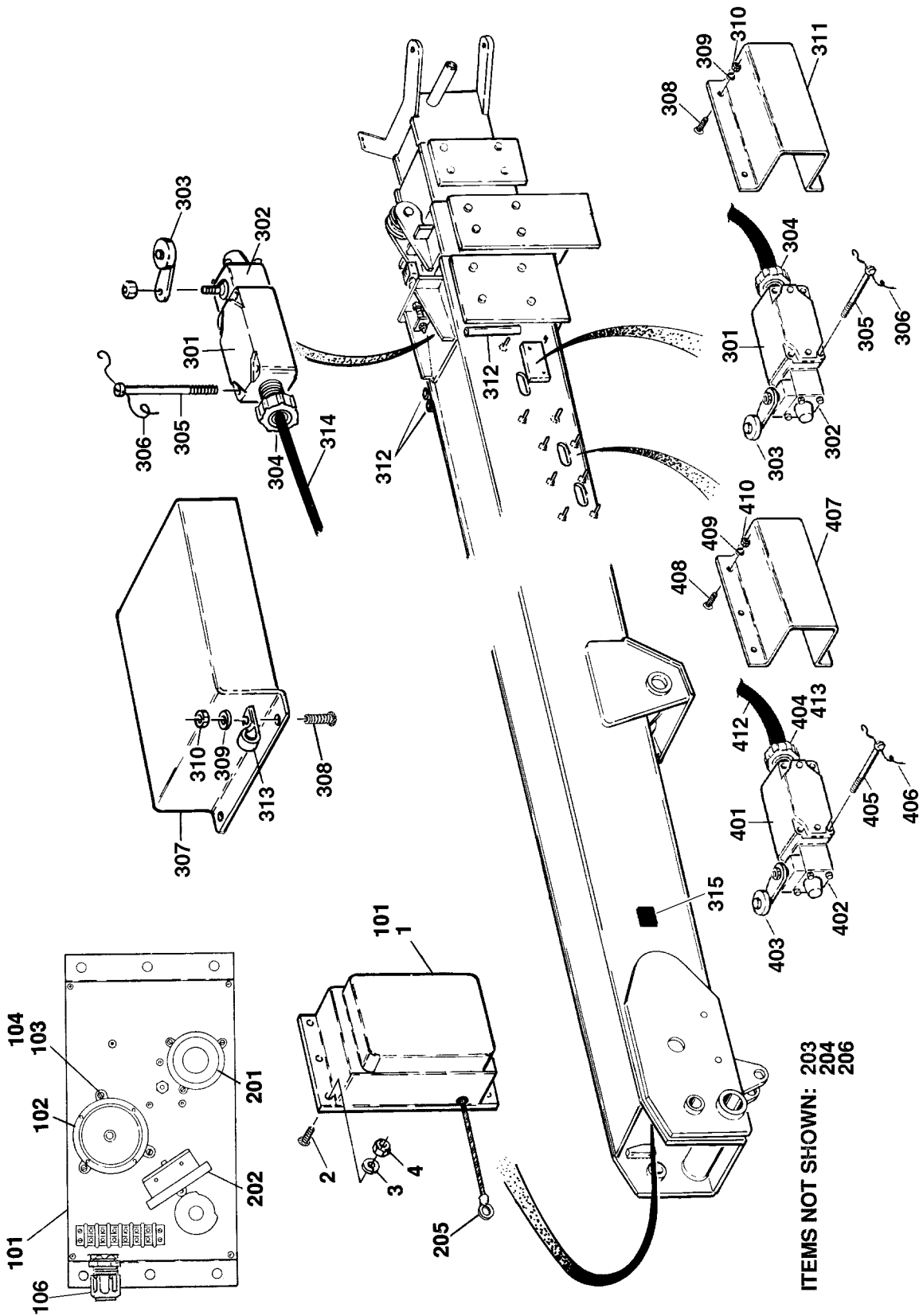

# SECTION 3 BOOM

**FIGURE 3-5. BOOM LENGTH INDICATOR AND LIMIT SWITCHES INSTALLATION**

FIG & ITEM #	PART NUMBER	DESCRIPTION	QTY.	REV.
	0250119	<b>BOOM LENGTH/INDICATOR INSTALLATION</b>	Ref.	2
1	0239485	Boom Length Indicator Assembly (See Item 101-104 for Breakdown)	1	
2	4300032	Stud (Welded on Part)	4	
3	4761400	Lockwasher 1/4"	4	
4	3311401	Nut 1/4"-20NC	4	
	0239485	<b>BOOM LENGTH INDICATOR SUBASSEMBLY</b>	Ref.	D
101	0860575	Indicator Box Assembly (See Items 201-206 for Breakdown)	1	
102	4360153	Pendulum	1	
103	3910408	Screw #4NC x 1/2"	4	
104	4770400	Starwasher #4	4	
105	Not Used			
106	4460428	Strain Relief	1	
	0860575	<b>INDICATOR BOX ASSEMBLY</b>	Ref.	E
201	7000637	Potentiometer	1	
	70002305	Holder, Potentiometer	1	
202	7000638	Switch	1	
203	7000639	Spring, Reel	1	
204	7012526	Spring, Extension	1	
205	7000647	Cable	1	
206	3730024	Resistor - 100 Ohms	1	
		<b>BOOM LIMIT SWITCHES INSTALLATIONS</b>	Ref.	
	0270234	<b>AUSTRALIAN</b>	Ref.	3
	0270235	<b>CE</b>	Ref.	3
301	4360277	Switch, Limit	A/R	
302	4360236	Switch, Head	A/R	
303	4360278	Switch, Roller Arm	A/R	
304		Connector, Strain Relief Options:	A/R	
	4460052	Prior to S/N 56617		
	4460049	S/N 56617 to Present		
305	3900168	Screw #10-24NC x 1 1/2"	A/R	
306	4920140	Wire, Safety	A/R	
307	3533183	Plate, Cover (CE Machines Only)	1	
308	4300031	Stud (Welded on Part) (CE Machines Only)	4	
309	4761400	Lockwasher 1/4"	A/R	
310	3311401	Nut 1/4"-20NC	A/R	
311	1670579	Cover	1	
312	4564880	Tube, Cable (CE Machines Only)	1	
313	1320040	Clamp, Cable	2	
314	1060016	Cable, Control (CE Machines Only)	50ft/15.2m	
315	1670836	Cover, Boom	2	

# SECTION 3 BOOM

**FIGURE 3-5. BOOM LENGTH INDICATOR AND LIMIT SWITCHES INSTALLATION (CONTINUED)**

FIG & ITEM #	PART NUMBER	DESCRIPTION	QTY.	REV.
316 to 318	Not Used			
	0270824	<b>BOOM LENGTH LIMIT SWITCHES INSTALLATIONS (120SXJ ONLY)</b>	Ref.	1
401	4360277	Switch, Limit	2	
402	4360236	Switch, Head	2	
403	4360278	Switch, Roller Arm	2	
404	4460049	Connector, Strain Relief	1	
405	3900168	Screw #10-24NC x 1 1/2"	4	
406	4920140	Wire, Safety	2	
407	3572637	Plate, Cover	1	
408	4300031	Stud (Welded on Part)	6	
409	4761400	Lockwasher 1/4"	10	
410	3311401	Nut 1/4"-20NC	10	
411	1320245	Clamp, Cable (Not Shown)	6	
412	1060016	Cable, Control	52ft/15.8m	
413	4460052	Connector, Strain Relief	1	

**SECTION 3 BOOM**

# SECTION 3 BOOM

FIGURE 3-5. BOOM LENGTH INDICATOR AND LIMIT SWITCHES INSTALLATION (CONTINUED)

FIG & ITEM #	PART NUMBER	DESCRIPTION	QTY.	REV.

**S  
E  
C  
T  
I  
O  
N  
  
3  
  
B  
O  
O  
M**

# SECTION 3 BOOM

FIGURE 3-6. BOOM WIPERS INSTALLATION

SECTION 3 BOOM

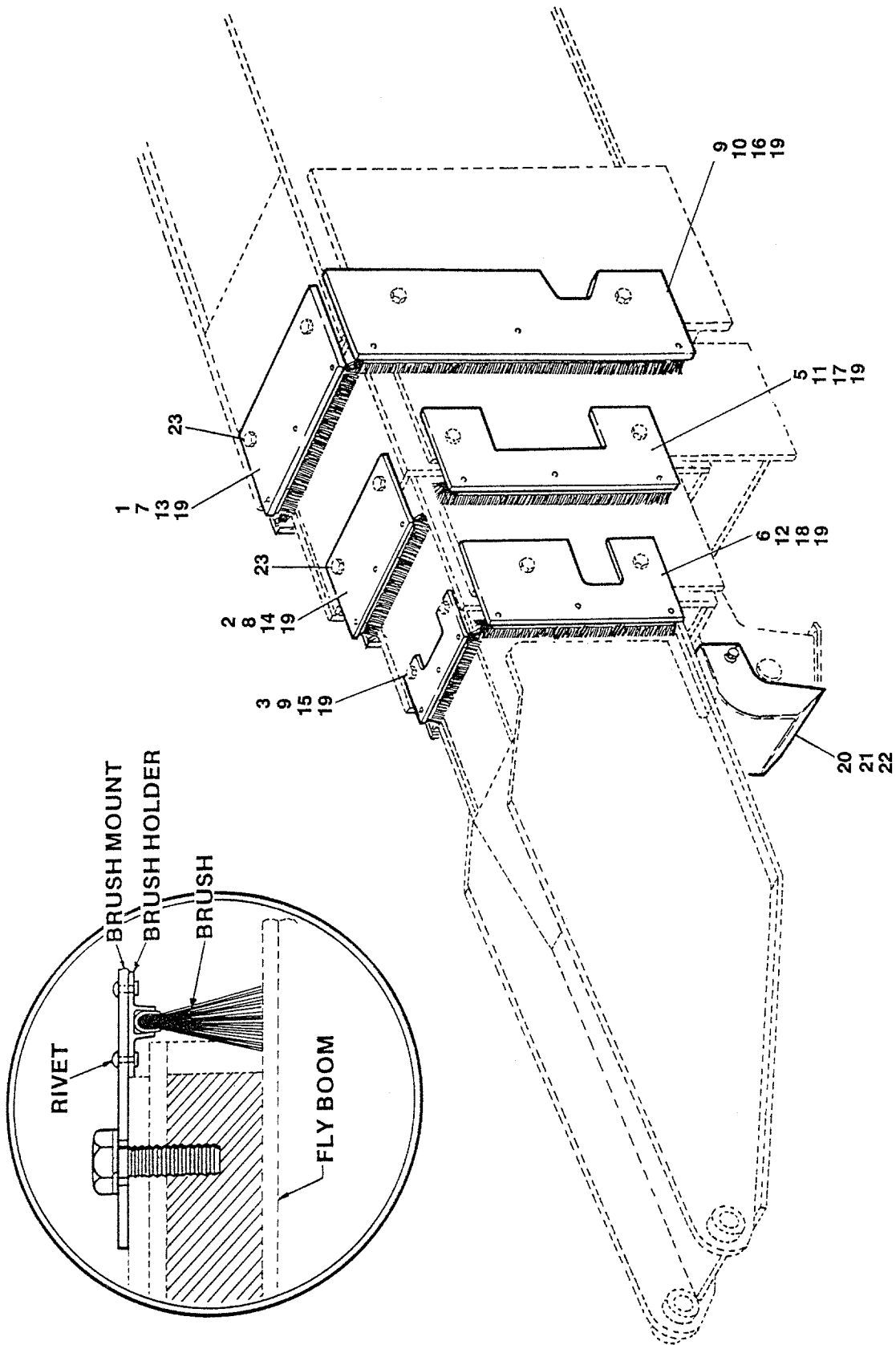



# SECTION 3 BOOM

**FIGURE 3-6. BOOM WIPERS INSTALLATION**

FIG & ITEM #	PART NUMBER	DESCRIPTION	QTY.	REV.
	0253303	<b>BOOM WIPERS INSTALLATION</b>	Ref.	2
1	3200344	Mount, Boom Wiper (Base/Top)	1	
2	3200346	Mount, Boom, Wiper (Inner Mid/Top)	2	
3	3200348	Mount, Boom, Wiper (Outer Mid/Top)	1	
4	3200345	Mount, Boom, Wiper (Base/Side)	2	
5	3200347	Mount, Boom Wiper (Inner Mid/Side)	2	
6	3200349	Mount, Boom Wiper (Outer Mid/Side)	2	
7	0540074	Blade, Boom Wiper (Base/Top)	1	
8	0540089	Blade, Boom Wiper (Inner Mid/Top)	2	
9	0540078	Blade, Boom Wiper (Outer Mid/Top)	1	
10	0540075	Blade, Boom Wiper (Base/Side)	2	
11	0540077	Blade, Boom Wiper (Inner Mid/Side)	2	
12	0540079	Blade, Boom Wiper (Outer Mid/Side)	2	
13	2660067	Holder, Brush (Base/Top)	1	
14	2660085	Holder, Brush (Inner Mid/Top)	2	
15	2660071	Holder, Brush (Outer Mid/Top)	1	
16	2660068	Holder, Brush (Base/Side)	2	
17	2660070	Holder, Brush (Inner Mid/Side)	2	
18	2660072	Holder, Brush (Outer Mid/Side)	2	
19	3820001	Rivet, Pop	30	
20	1670491	Cover Weldment	1	
21	0641404	Bolt 1/4" -20NC x 1/2"	4	
22	4761400	Lockwasher	4	
23	4711600	Flatwasher	4	

**SECTION 3 BOOM**

# SECTION 3 BOOM

FIGURE 3-6. BOOM WIPERS INSTALLATION (CONTINUED)

FIG & ITEM #	PART NUMBER	DESCRIPTION	QTY.	REV.

**S  
E  
C  
T  
I  
O  
N  
  
3  
  
B  
O  
O  
M**

# SECTION 4 PLATFORMS

<b>TABLE OF CONTENTS</b>		
<b>FIGURE</b>	<b>DESCRIPTION</b>	<b>PAGE</b>
4-1	PLATFORM COMPONENTS INSTALLATION . . . . .	4-2
4-2	PLATFORM SUPPORT & ROTATOR INSTALLATION (100SX/110SX) . . . . .	4-6
4-3	PLATFORM SUPPORT & ROTATOR INSTALLATION (110SXJ/120SXJ) . . . . .	4-10
4-4	ROTATOR MOTOR ASSEMBLY . . . . .	4-12
4-5	PLATFORM CONSOLE ASSEMBLY . . . . .	4-14
4-6	CONTROLLER ASSEMBLY (LIFT & SWING) . . . . .	4-18
4-7	CONTROLLER ASSEMBLY (DRIVE & STEER) . . . . .	4-20
4-8	CONTROLLER ASSEMBLY (SPEED) . . . . .	4-24
4-9	SOFT TOUCH SYSTEM INSTALLATION . . . . .	4-26

SECTION 4 PLATFORMS

# SECTION 4 PLATFORMS

FIGURE 4-1. PLATFORM COMPONENTS INSTALLATION

SECTION 4 PLATFORMS

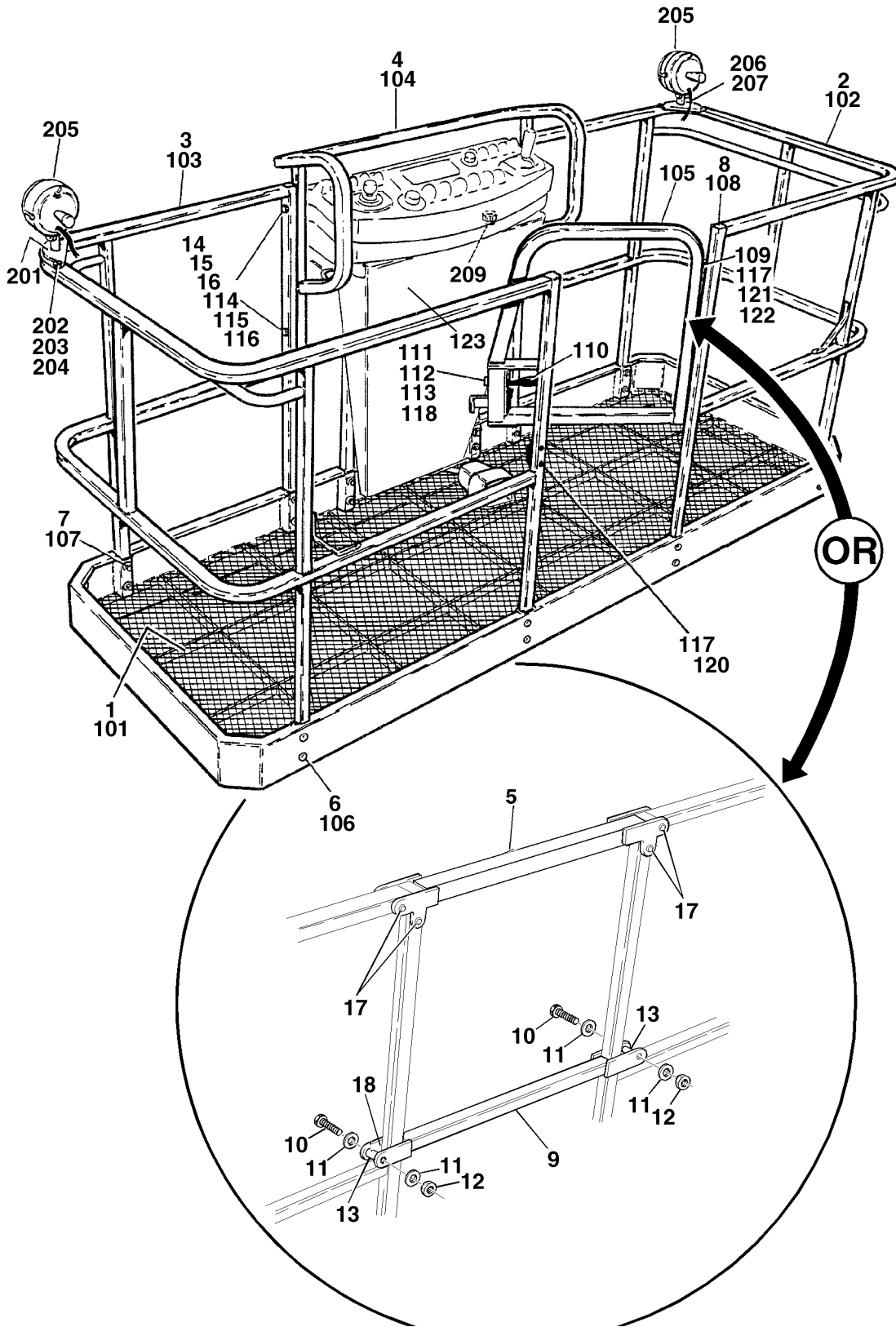

# SECTION 4 PLATFORMS

**FIGURE 4-1. PLATFORM COMPONENTS INSTALLATION**

FIG & ITEM #	PART NUMBER	DESCRIPTION	QTY.	REV.
		<b>PLATFORM ASSEMBLIES STANDARD:</b>		
	3510499	<b>6ft (1.83m)</b>	Ref.	3
	3510500	<b>8ft (2.44m)</b>	Ref.	2
		<b>Note: Replacement decals must be ordered separately - See Section 8.</b>		
1		Floor Weldment Options:	1	
	4845290	6ft Platform		
	4845289	8ft Platform		
2		Rail Weldment - Right Side Options:	1	
	4844955	6ft Platform		
	4844924	8ft Platform		
3		Rail Weldment - Left Side Options:	1	
	4844956	6ft Platform		
	4844925	8ft Platform		
4	4845328	Rail Weldment - Back	1	
5	4845287	Rail Weldment - Top	1	
6	3900207	Fastener	A/R	
		<b>(Note: P/N 3900207 Fastener may be replaced with P/N 0641416 Bolt, P/N 4751400 Flatwasher, P/N 3311405 Locknut and P/N3300151 Acorn Type Nut. Acorn type nut is required to meet industry safety requirements.</b>	Ref.	
7	3300393	Collar	A/R	
8	3520072	Plug, Cap	A/R	
9	4845288	Weldment, Lift Gate	1	
10	0641418	Bolt 1/4"-20NC x 2 1/4"	2	
11	4740411	Washer, Nylon	4	
12	3300151	Nut Acorn 1/4"-20NC	2	
13	0961845	Bushing	2	
14	0641524	Bolt 5/16"-18NC x 3"	4	
15	3311505	Locknut 5/16"-18NC	4	
16	4751500	Flatwasher 5/16"	4	
17	2080040	Fastener	8	
18	4420055	Tape, UHMW	A/R	
		<b>PLATFORM ASSEMBLIES SELF-CLOSING GATE:</b>		
	3510542	<b>6ft (1.83m) With Self-Closing Gate</b>	Ref.	2
	3510543	<b>8ft (2.44m) With Self-Closing Gate</b>	Ref.	2
101		Floor Weldment Options:	1	
	4844954	6ft Platform		
	4844928	8ft Platform		
102		Rail Weldment - Right Side Options:	1	
	4844955	6ft Platform		
	4844924	8ft Platform		
103		Rail Weldment - Left Side Options:	1	
	4844956	6ft Platform		
	4844925	8ft Platform		
104	4845328	Rail Weldment - Back	1	

**SECTION 4 PLATFORMS**

# SECTION 4 PLATFORMS

**FIGURE 4-1. PLATFORM COMPONENTS INSTALLATION (CONTINUED)**

FIG & ITEM #	PART NUMBER	DESCRIPTION	QTY.	REV.
105	4845426	Gate Weldment	1	
106	3900207	Fastener <b>(Note: P/N 3900207 Fastener may be replaced with P/N 0641416 Bolt, P/N 4751400 Flatwasher, P/N 3311405 Locknut and P/N3300151 Acorn Type Nut. Acorn type nut is required to meet industry safety requirements.</b>	A/R  Ref.	
107	3300393	Collar	A/R	
108	3520072	Plug, Cap	A/R	
109	2600219	Hinge	2	
110	2940074	Latch	1	
111	3911008	Screw #10-24NC x 1/2"	4	
112	4751000	Flatwasher #10	4	
113	3311005	Locknut #10-24NC	4	
114	0641524	Bolt 5/16"-18NC x 3"	4	
115	3311505	Locknut 5/16"-18NC	4	
116	4751500	Flatwasher 5/16"	4	
117	2080040	Fastener	13	
118	4761000	Lockwasher 3/8"	4	
119	Not Used			
120	3539685	Plate, Latch	1	
121	4220165	Stop, Gate	1	
122	4060803	Trim	6ft/1.8m	
123	3380434	Panel, Pedestal	1	
		<b>WORKLIGHTS INSTALLATIONS (OPTIONAL)</b>	Ref.	
	0258048	<b>Prior to S/N 64504</b>	Ref.	2/E
	0271629	<b>S/N 64504 to Present</b>	Ref.	1/A
201	3536089	Plate, Mounting	2	
202	0641414	Bolt 1/4"-20NC x 1 3/4"	4	
203	3311405	Locknut 1/4"-20NC	4	
204	4711400	Flatwasher 1/4" Narrow	8	
205	2920140	Worklight	2	
	7016399	Bulb, Replacement (1 Per Worklight)	2	
206	4240099	Tie-Strap (Not Shown)	10	
207	2820035	Loom, Vinyl (Not Shown)	9	
208	Not Used			
209	4460598	Connector, Strain Relief (Not Shown - Located at Console Box)	1	
210	4920018	Wire (Not Shown) (Prior to S/N 64504)	A/R	

**SECTION 4 PLATFORMS**

# SECTION 4 PLATFORMS

FIGURE 4-1. PLATFORM COMPONENTS INSTALLATION (CONTINUED)

FIG & ITEM #	PART NUMBER	DESCRIPTION	QTY.	REV.

**S  
E  
C  
T  
I  
O  
N  
  
4  
  
P  
L  
A  
T  
F  
O  
R  
M  
S**

# SECTION 4 PLATFORMS

FIGURE 4-2. PLATFORM SUPPORT & ROTATOR INSTALLATION (100SX/110SX)

SECTION 4 PLATFORMS

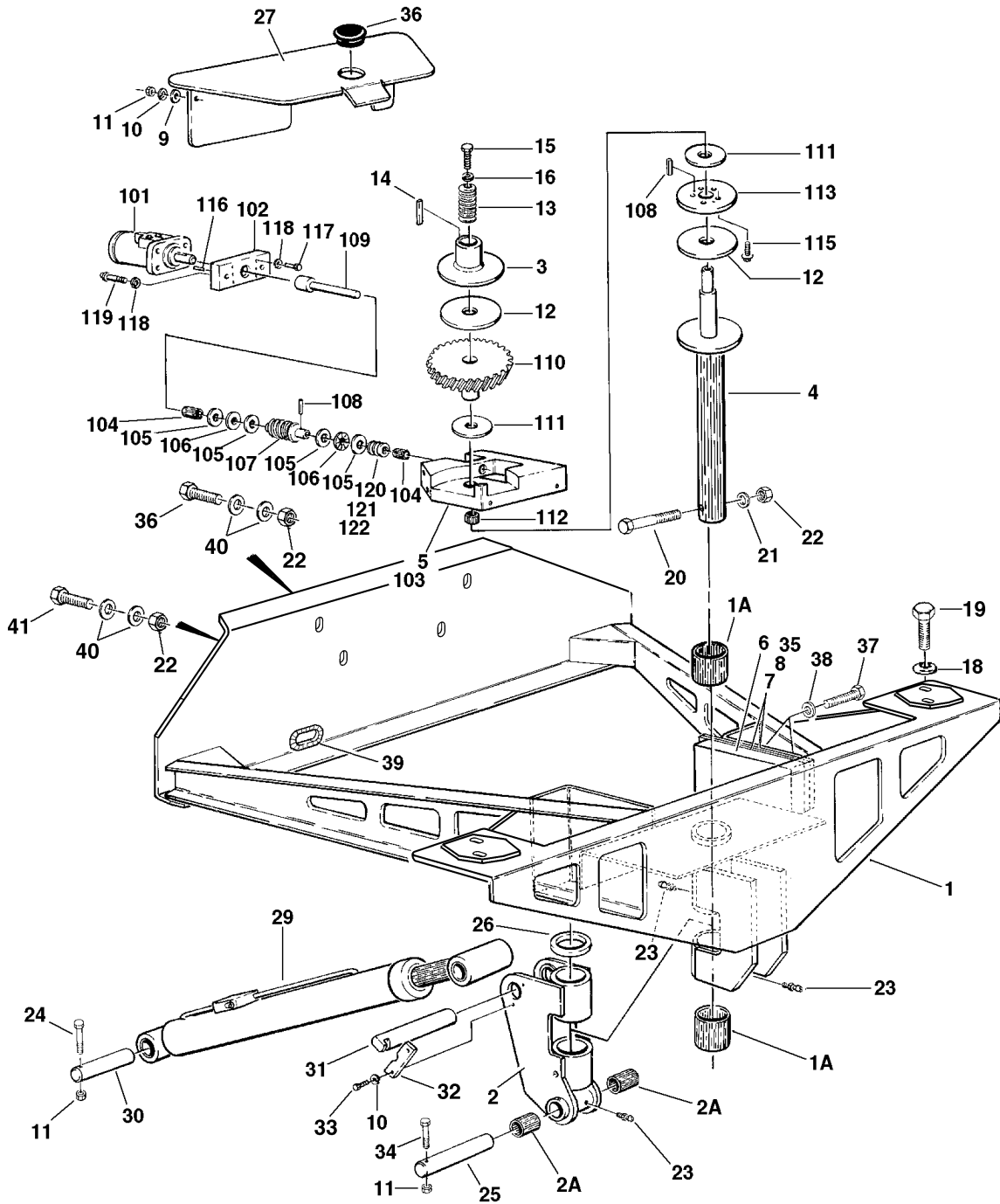



# SECTION 4 PLATFORMS

**FIGURE 4-2. PLATFORM SUPPORT & ROTATOR INSTALLATION (100SX/110SX)**

FIG & ITEM #	PART NUMBER	DESCRIPTION	QTY.	REV.
	0270276	<b>PLATFORM SUPPORT &amp; ROTATOR INSTALLATION</b>	Ref.	1/A
1	4846196	Weldment, Support	1	
1A	0961259	Bushing	2	
2	0239182	Pivot Weldment	1	
2A	0960565	Bushing, Bronze	2	
3	1120299	Cap	1	
4		Rotator Shaft Options:	1	
	4040220	Prior to S/N 67889		
	4842915	S/N 67889 to Present		
5	0235238	Rotator Assembly (See Items 101-126 for Breakdown)	1	
6	0361675	Bar, Stop	1	
7	4070705	Shim 1/8"	A/R	
8	4070706	Shim 1/16"	A/R	
9	4751500	Flatwasher 5/16"	2	
10	4761500	Lockwasher 5/16"	4	
11	3311501	Nut 5/16"-18NC	4	
12	3340454	Pad, Brake	2	
13	4160026	Washer, Belleville	8	
14	2880404	Key	1	
15	0652014	Bolt 5/8"-18NF x 1 3/4"	1	
16	4752000	Flatwasher 5/8"	1	
17	Not Used			
18	4711600	Flatwasher 3/8"	4	
19	0681610	Bolt 3/8"-16NC x 1 1/4" (Grade 8)	4	
20	0641840	Bolt 1/2"-13NC x 5"	1	
21	4751800	Flatwasher 1/2"	1	
22	3311805	Locknut 1/2"-13NC	5	
23	2160002	Fitting, Grease	3	
24	0641520	Bolt 5/16"-18NC x 2 1/2"	1	
25	3422147	Pin	1	
26	4740158	Washer, Thrust	1	
27	1670451	Cover	1	
28	4300038	Stud (Welded on part - Not Shown)	2	
29		Platform Level Cylinder Assembly Options (See Section 5 for Breakdown):	1	
	1682590	Prior to S/N 56302		
	1683536	S/N 56302 to Present		
30	3421582	Pin	1	
31	3421577	Pin	1	
32	3532054	Plate, Retainer	1	
33	0641506	Bolt 5/16"-18NC x 3/4"	2	
34	0641524	Bolt 5/16"-18NC x 3"	1	
35	4070707	Shim 1/32"	2	
36	0641818	Bolt 1/2"-13NC x 2 1/4"	2	
37	0641816	Bolt 1/2"-13NC x 2"	2	
38	4761800	Lockwasher 1/2"	2	
39	4060804	Flexguard	10.5in/27cm	
40	4711600	Flatwasher 1/2"	8	

**SECTION 4 PLATFORMS**

# SECTION 4 PLATFORMS

**FIGURE 4-2. PLATFORM SUPPORT & ROTATOR INSTALLATION (100SX/110SX) (CONTINUED)**

FIG & ITEM #	PART NUMBER	DESCRIPTION	QTY.	REV.
41	0641820	Bolt 3/8"-16NC x 2 1/2"	2	
	0235238	<b>ROTATOR ASSEMBLY</b>	Ref.	E
101	3160083	Rotator Motor Assembly (See Figure 4-4 for Break-down)	1	
102	0080099	Adapter, Motor	1	
103	2760064	Housing, Gear	1	
104	0440134	Bearing, Sleeve	2	
105	4740199	Washer, Thrust	4	
106	0440120	Bearing, Thrust	2	
107	2440043	Gear, Worm	1	
108	3440816	Rollpin 1/4" x 1"	4	
109	0080098	Adapter, Motor to Worm Gear	1	
110	2440044	Gear, Worm	1	
111	4740256	Washer, Thrust	2	
112	0440135	Bearing, Sleeve	1	
113	1760068	Disc, Brake	1	
114	Not Used			
115	3931010	Bolt, Socket Head #10-24NC x 5/8"	5	
116	3441228	Rollpin 3/8" x 1 3/4"	2	
117	3931620	Bolt, Socket Head 3/8"-16NC x 1 1/4"	2	
118	4761600	Lockwasher 3/8"	6	
119	3931612	Bolt, Socket Head 3/8"-16NC x 3/4"	4	
120	4070585	Shim.010	A/R	
121	4070586	Shim.005	A/R	
122	4070587	Shim.002	A/R	
123	0100019	Loctite #271 (Not Shown)	A/R	
124	0100021	Primer (Not Shown)	A/R	
125	2160001	Fitting, Grease - 90° (Not Shown)	1	
126	3020025	Grease (Not Shown)	A/R	

SECTION 4 PLATFORMS

# SECTION 4 PLATFORMS

FIGURE 4-2. PLATFORM SUPPORT & ROTATOR INSTALLATION (100SX/110SX) (CONTINUED)

FIG & ITEM #	PART NUMBER	DESCRIPTION	QTY.	REV.

**S  
E  
C  
T  
I  
O  
N  
  
4  
  
P  
L  
A  
T  
F  
O  
R  
M  
S**

# SECTION 4 PLATFORMS

FIGURE 4-3. PLATFORM SUPPORT & ROTATOR INSTALLATION (110SXJ/120SXJ)

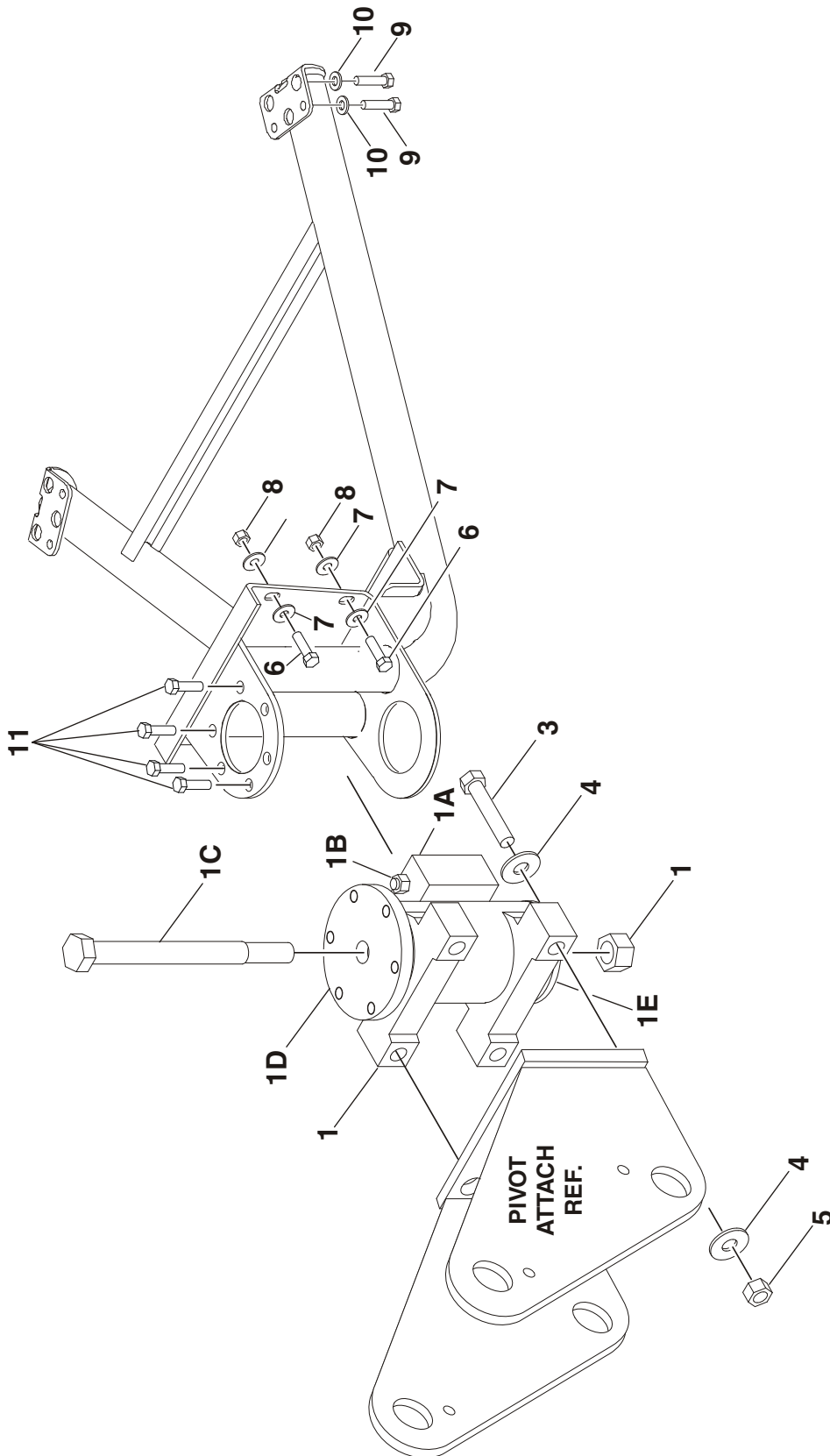

# SECTION 4 PLATFORMS

**FIGURE 4-3. PLATFORM SUPPORT & ROTATOR INSTALLATION (110SXJ/120SXJ)**

FIG & ITEM #	PART NUMBER	DESCRIPTION	QTY.	REV.
	0259974	<b>PLATFORM SUPPORT &amp; ROTATOR INSTALLATION</b>	Ref.	4/B
1	0060053	Actuator	1	
1A	Use 7017183	Block Valve Assembly (was p/n 7017101)	1	
1B	7017193	Cartridge	2	
1C	7017119	Bolt 1"-8NC x 11"	1	
1D	7017177	Shaft Weldment	1	
1E	7017174	Cap, End	1	
1F	7017142	Kit, Hardware (Not Shown)	1	
1G	7017156	Kit, Bearing (Not Shown)	1	
1H	7017157	Kit, Seal (Not Shown)	1	
2	4844790	Weldment, Platform Support	1	
3	0682234	Bolt 3/4"-10NC x 4 1/4" (Grade 8)	4	
4	4892200	Washer, Hardened 3/4"	8	
5	3272201	Nut 3/4"-10NC (Grade 8)	4	
6	0641820	Bolt 1/2"-13NC x 2 1/2"	4	
7	4711800	Flatwasher 1/2"	8	
8	3311805	Locknut 1/2"-13NC	4	
9	0681610	Bolt 3/8"-16NC x 1 1/4" (Grade 8)	4	
10	4711600	Flatwasher 3/8"	4	
11	0641808	Bolt 1/2"-13NC x 1"	6	
12	Not Used			
13	Not Used			
	0100019	----- Loctite #271	A/R	
	0100011	Loctite #242	A/R	

**SECTION 4 PLATFORMS**

# SECTION 4 PLATFORMS

FIGURE 4-4. ROTATOR MOTOR ASSEMBLY

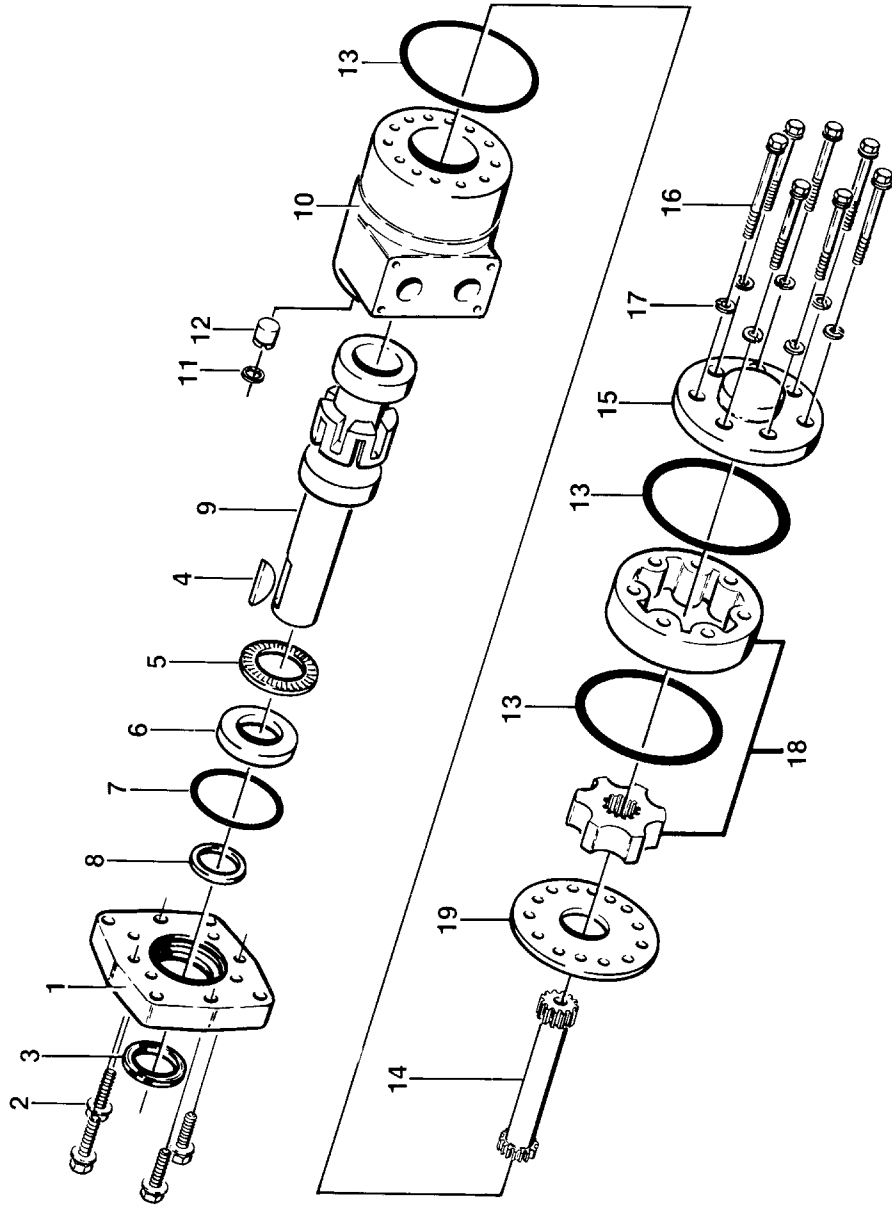

SECTION 4 PLATFORMS

# SECTION 4 PLATFORMS

**FIGURE 4-4. ROTATOR MOTOR ASSEMBLY**

FIG & ITEM #	PART NUMBER	DESCRIPTION	QTY.	REV.
	3160083	<b>ROTATOR MOTOR ASSEMBLY</b>	Ref.	A
1	7002105	Flange, Mounting	1	
2	7002123	Screw, Cap	4	
3	Kit	Seal, Dust	1	
4	7002104	Key, Woodruff	1	
5	7002111	Bearing, Thrust Needle	1	
6	7002117	Thrust, Bearing Race	1	
7	Kit	Seal, O-Ring	1	
8	Kit	Seal, Pressure	1	
9	7002116	Shaft, Output	1	
10	7002103	Housing	1	
11	Kit	Seal	1	
12	Kit	Plug, Housing	1	
13	7002115	Seal, O-Ring	3	
14	7002112	Drive	1	
15	7002107	Cap, End	1	
16	7002100	Screw, Cap	7	
17	7000166	Lockwasher	7	
18	7002125	Gerotor Sub-Assembly	1	
19	7002110	Plate, Spacer	1	
	2900455	Seal Kit (Includes Items 3,7,8,11 and 12) (P/N 101-1009-007)	1	
	2900733	Seal Kit (Includes Items 3,7,8,11 and 12) (P/N's 101-1009-008 and 101-1009-009)	1	
		<b>Note: Identify by P/N stamped on nameplate located on Item 10.</b>	Ref.	

SECTION 4 PLATFORMS

# SECTION 4 PLATFORMS

FIGURE 4-5. PLATFORM CONSOLE ASSEMBLY

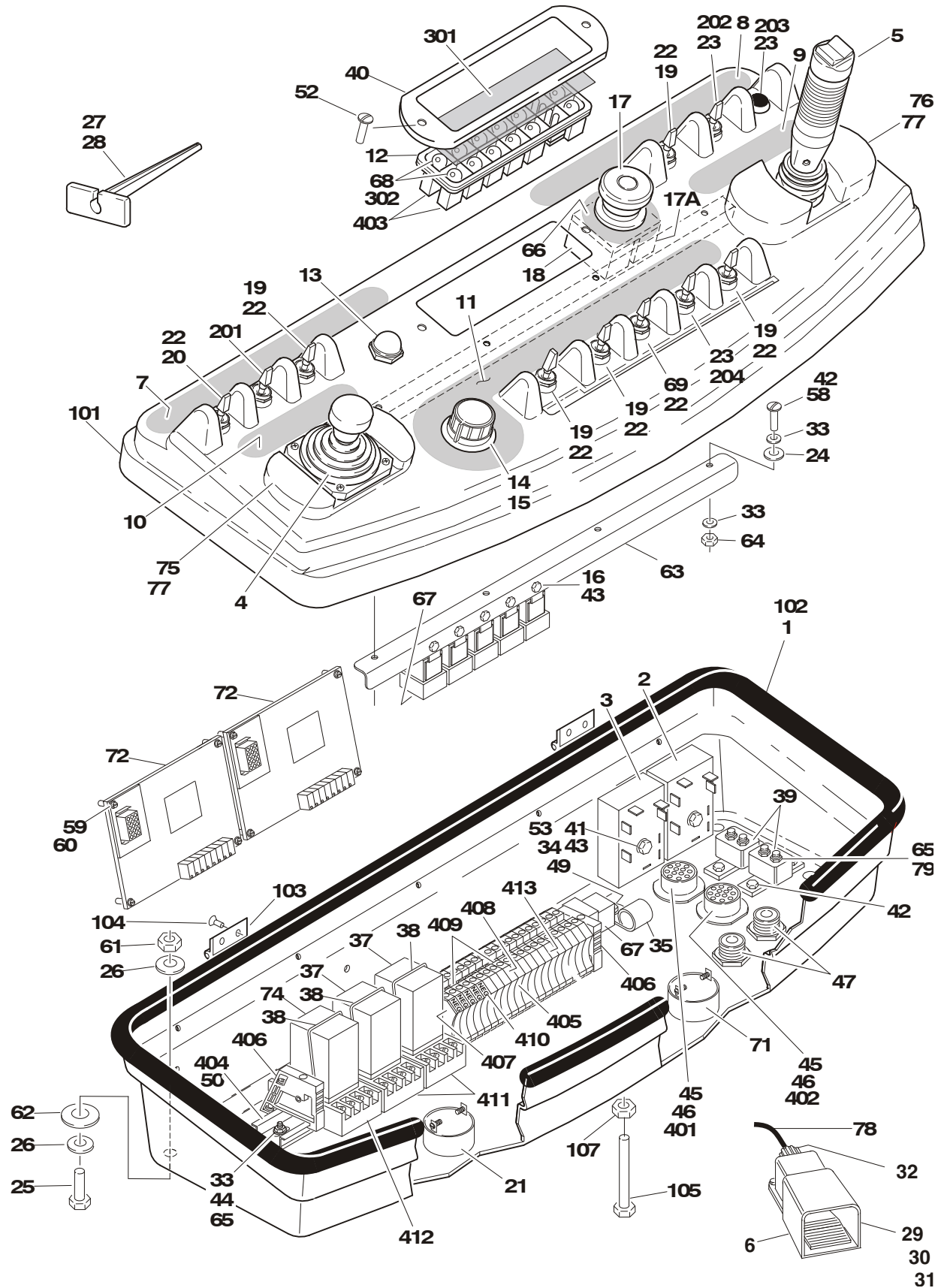

SECTION 4 PLATFORMS



# SECTION 4 PLATFORMS

**FIGURE 4-5. PLATFORM CONSOLE ASSEMBLY**

FIG & ITEM #	PART NUMBER	DESCRIPTION	QTY.	REV.
		<b>CONSOLE BOX ASSEMBLIES</b>	Ref.	
	0861370	<b>100SX/110SX - 2W/S</b>	Ref.	5
	0861369	<b>100SX/110SX - 4W/S</b>	Ref.	5
	0861371	<b>110SXJ - 2W/S</b>	Ref.	5
	0861368	<b>110SXJ - 4W/S</b>	Ref.	5
	0861367	<b>120SXJ - 4W/S</b>	Ref.	5
1	Use 0861640	Box, Console Assembly (See Items 101-107 for Breakdown) (was p/n 0861353)	1	
2	3740113	Relay, Time Delay	1	
3	3740115	Relay, Time Delay	1	
4	1600306	Controller Assembly (Lift & Swing) (See Figure 4-6 for Breakdown)	1	
5	1600287	Controller Assembly (Drive & Steer) (See Figure 4-7 for Breakdown)	1	
6	4360031	Footswitch	1	
	7000625	Block, Contact	2	
7	1702676	Decal (Horn/Drive Speed/Level)	1	
8	1702564	Decal (Stop)	1	
9	1704520	Decal (Drive and Steer)	1	
10	1702566	Decal (Lift and Swing)	1	
11	1704511	Decal (Speed/Lower Lift/Tele/Rotate/Jib)	1	
12	2760105	Housing, Display Light	1	
13	4360387	Switch, Pushbutton	1	
14	2560136	Knob, Speed Control	1	
15	1600272	Controller, Speed (See Figure 4-8 for Breakdown)	1	
16	0791004	Screw #10-24NC	7	
17	4360475	Switch, Emergency Stop	1	
17A	7020175	Cap, Red	1	
	7020176	Contact Block		
18	4360476	Block, Contact	1	
19	4360314	Switch, Toggle	A/R	
20	4360331	Switch, Toggle	1	
21	0140026	Alarm	1	
22	3790012	O-Ring	7	
23	3520028	Plug, Hole (For switch call-outs at these locations, refer to options installation below)	4	
24	4740120	Washer, Nylon #10 (Prior to S/N 79464)	A/R	
25	0641611	Bolt 3/8"-16NC x 1 3/8"	4	
26	4751600	Flatwasher 3/8"	A/R	
27	4460467	Tool, Pin Extraction (Blue 16-18 Gauge) (Not Shown)	1	
28	4460510	Tool, Pin Extraction (Yellow 12-14 Gauge) (Not Shown)	1	
29	0641408	Bolt 1/4"-20NC x 1"	3	
30	3311405	Locknut 1/4"-20NC	A/R	
31	4740362	Washer, Fender 1/4"	A/R	
32	4460071	Connector, Strain Relief	1	
33	4711000	Flatwasher #10 (Narrow)	2	
34	3311401	Nut 1/4"-20NC	1	
35	1320060	Clamp	1	

**SECTION 4 PLATFORMS**

# SECTION 4 PLATFORMS

**FIGURE 4-5. PLATFORM CONSOLE ASSEMBLY (CONTINUED)**

FIG & ITEM #	PART NUMBER	DESCRIPTION	QTY.	REV.
36	4460234	Mount, Wire Strap	6	
37	3740123	Relay	2	
38	3740124	Spring, Relay	A/R	
39	4360232	Breaker, Circuit - 15 Amp	2	
40	1670829	Bezel	1	
41	0721010	Screw, Machine #10-24NC x 1 1/4"	2	
42	0721003	Screw, Machine #10-24NC x 3/8"	2	
43	3300365	Nut, Retainer	7	
44	0731004	Bolt #10-32NF x 1/2"	2	
45	4460470	Nut, Conduit	2	
46	4460471	Washer	2	
47	4460428	Connector, Strain Relief	2	
48	0100029	Silicone (Not Shown)	A/R	
49	0641406	Bolt 1/4"-20NC x 3/4"	1	
50	4420038	Foam, Self Adhesive	6in/15.3cm	
51	Not Used			
52	0630464	Screw, Button Head #10-24NC x 1/2"	2	
53	4751400	Flatwasher 1/4"	8	
54	0100011	Loctite #242 (Not Shown)	A/R	
55	0100035	Loctite #222 (Not Shown)	A/R	
56	3380434	Panel, Pedestal	1	
57	0641406	Bolt 1/4"-20NC x 3/4"	4	
58	0630518	Screw, Button Head #10-24NC x 3/4" (Prior to S/N 79464)	A/R	
59	3910812	Screw #8-32NC x 1/2"	8	
60	4750800	Flatwasher #8 (Wide)	8	
61	3311605	Locknut 3/8"-16NC	4	
62	4751800	Flatwasher 1/2" (Wide)	4	
63	3539275	Plate, Mounting	1	
64	3300408	Locknut #10-24NC, Nylon Insert (Prior to S/N 79464)	A/R	
65	4761000	Lockwasher #10	2	
66	1704260	Decal - EMS	1	
67	3740049	Relay, Bosch	A/R	
68	2920129	Bulb, Light	A/R	
69	4360345	Switch, Toggle	1	
70	Not Used			
71	0140019	Alarm	1	
72	1600307	Card, Flow Control	2	
73	4922422	Harness, Footswitch Power (Not Shown)	1	
74	3740122	Relay	A/R	
75	4340678	Support, Hand	1	
76	4340684	Support, Hand	1	
77	0641404	Bolt 1/4"-20NC x 1/2"	8	
78	Use 1060515	Electrical, Cable 12/4	6ft/1.8m	
	1060012	Prior to S/N 60492		
	1060515	S/N 60492 to Present		
	0100020	Sealant	A/R	

**SECTION 4 PLATFORMS**

# SECTION 4 PLATFORMS

**FIGURE 4-5. PLATFORM CONSOLE ASSEMBLY (CONTINUED)**

FIG & ITEM #	PART NUMBER	DESCRIPTION	QTY.	REV.
		<b>CONSOLE BOX ASSEMBLIES:</b>	Ref.	
	Use 0861640	<b>Production (was p/n 0861353)</b>	Ref.	1/A
	0861640	<b>Post Production Alternative</b>	Ref.	
101	Not Available	Lid, Cast	1	
102	Not Available	Bottom, Box	1	
103	2600211	Hinge (Used on p/n 0861353)	2	
104	3900224	Capscrew, Socket Head Countersunk 6mm x 16mm (Used on p/n 0861353)	8	
105	3931672	Capscrew, Socket Head 3/8"-16NC x 4 1/2"	1	
106	0100011	Loctite #242 (Not Shown) (Used on p/n 0861353)	A/R	
107	3311601	Nut 3/8"-16NC	1	
		<b>CONSOLE BOX OPTIONS</b>	Ref.	
201		4WS Switch Option Components	A/R	
	4360331	Switch, Toggle	1	
	3790012	O-Ring	1	
202		Dual Switch Option Components	A/R	
	4360336	Switch, Toggle	1	
	3790012	O-Ring	1	
203		Lights Switch Option Components	A/R	
	4360336	Switch, Toggle	1	
	3790012	O-Ring	1	
204		Articulating Jib Switch Option Components	A/R	
	4360314	Switch, Toggle	1	
	3790012	O-Ring	1	
	0259886	<b>LIGHT PANEL DECAL INSTALLATION</b>	Ref.	1
301	1704474	Decal - Light Panel Display	1	
302	2920129	Bulb, Light	A/R	
302	Not Used			
	4922418	<b>ELECTRICAL COMPONENTS INSTALLATION</b>	Ref.	3/D
401	4460503	Connector - 31 Position	1	
402	4460613	Connector - 21 Position	1	
403	4120035	Socket, Light	A/R	
404	3641182	Track	1	
405	4460601	Block, Terminal	24	
406	4460607	Stop, End	2	
407	4460602	Barrier, Terminal	1	
408	4460847	Marker, Terminal (1-10)	A/R	
409	4460603	Bar, Buss - 10 Position (Cut into [2] 5 Position Bars)	2	
410	4460631	Marker, Terminal (Negative)	1	
411	4120037	Socket, Relay	A/R	
412	4120036	Socket, Relay	A/R	
413	4460849	Marker, Terminal (11-20)	A/R	

**SECTION 4 PLATFORMS**

# SECTION 4 PLATFORMS

FIGURE 4-6. CONTROLLER ASSEMBLY (LIFT & SWING)

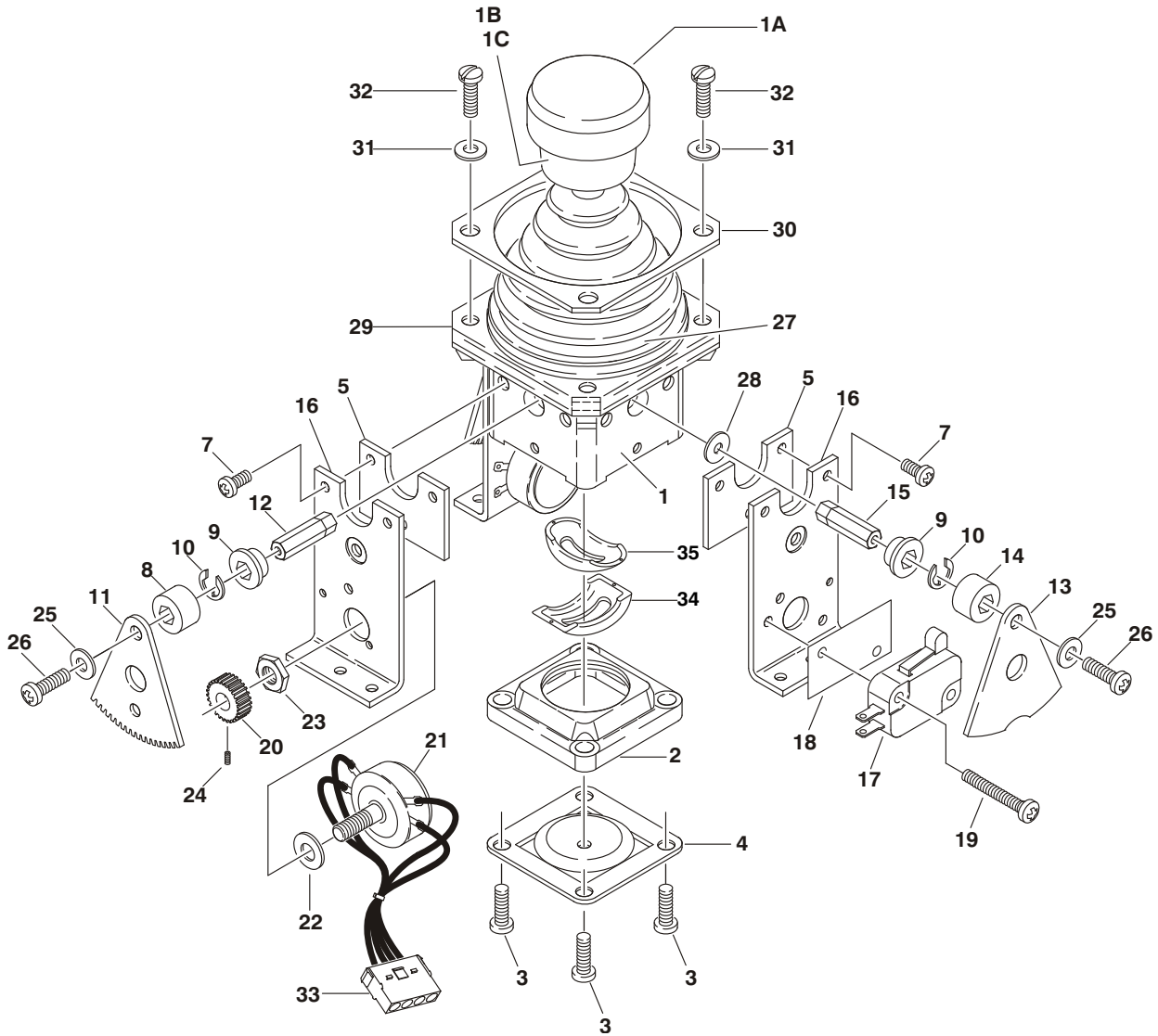

SECTION 4 PLATFORMS

# SECTION 4 PLATFORMS

**FIGURE 4-6. CONTROLLER ASSEMBLY (LIFT & SWING)**

FIG & ITEM #	PART NUMBER	DESCRIPTION	QTY.	REV.
	1600306	<b>CONTROLLER ASSEMBLY</b>	Ref.	D
1	7019141	Mechanical Assembly (Includes Base, Handle Stem & Items 1A, 1B, 1C & 27)	1	
1A	7019197	Handle/Cap/Rod Assembly	1	
1B	7003928	Spring	1	
1C	7022808	Cap, Lift	1	
2	7019169	Gate	1	
3	7003952	Screw	4	
4	7019170	Center, Detent	1	
5	7019171	Plate	2	
6	Not Used			
7	7019173	Screw	12	
8	7019144	Spacer, Cam	1	
9	7019111	Bearing, Gear	4	
10	7019145	E-Clip	4	
11	7003977	Gear, Drive	2	
12	7019147	Shaft	2	
13	7019175	Cam	2	
14	7019176	Spacer, Cam	2	
15	7019177	Shaft	2	
16	7019142	Plate	4	
17	7003961	Microswitch	2	
18	7019138	Insulator	2	
19	7019139	Screw	4	
20	7003976	Gear, Slave	2	
21	7019178	Potentiometer	2	
22	7003992	Washer	2	
23	7003993	Nut	2	
24	7019149	Setscrew	2	
25	7019144	Spacer	2	
26	7019143	Screw	2	
27	Use 7022813	Boot (Was P/N 7003955)	1	
28	7019146	Spacer, Cam	2	
29	Use 7022813	Plate, Plastic (Was P/N 7003954)	1	
30	7003956	O-Ring	1	
31	7003953	Washer	4	
32	7022811	Screw	4	
33	Not Available	Connector, Male - 4 Position	2	
	Not Available	Pin, Male	4	
34	7019122	Gimble, Outer	1	
35	7019123	Gimble, Inner	1	

SECTION 4 PLATFORMS

# SECTION 4 PLATFORMS

FIGURE 4-7. CONTROLLER ASSEMBLY (DRIVE & STEER)

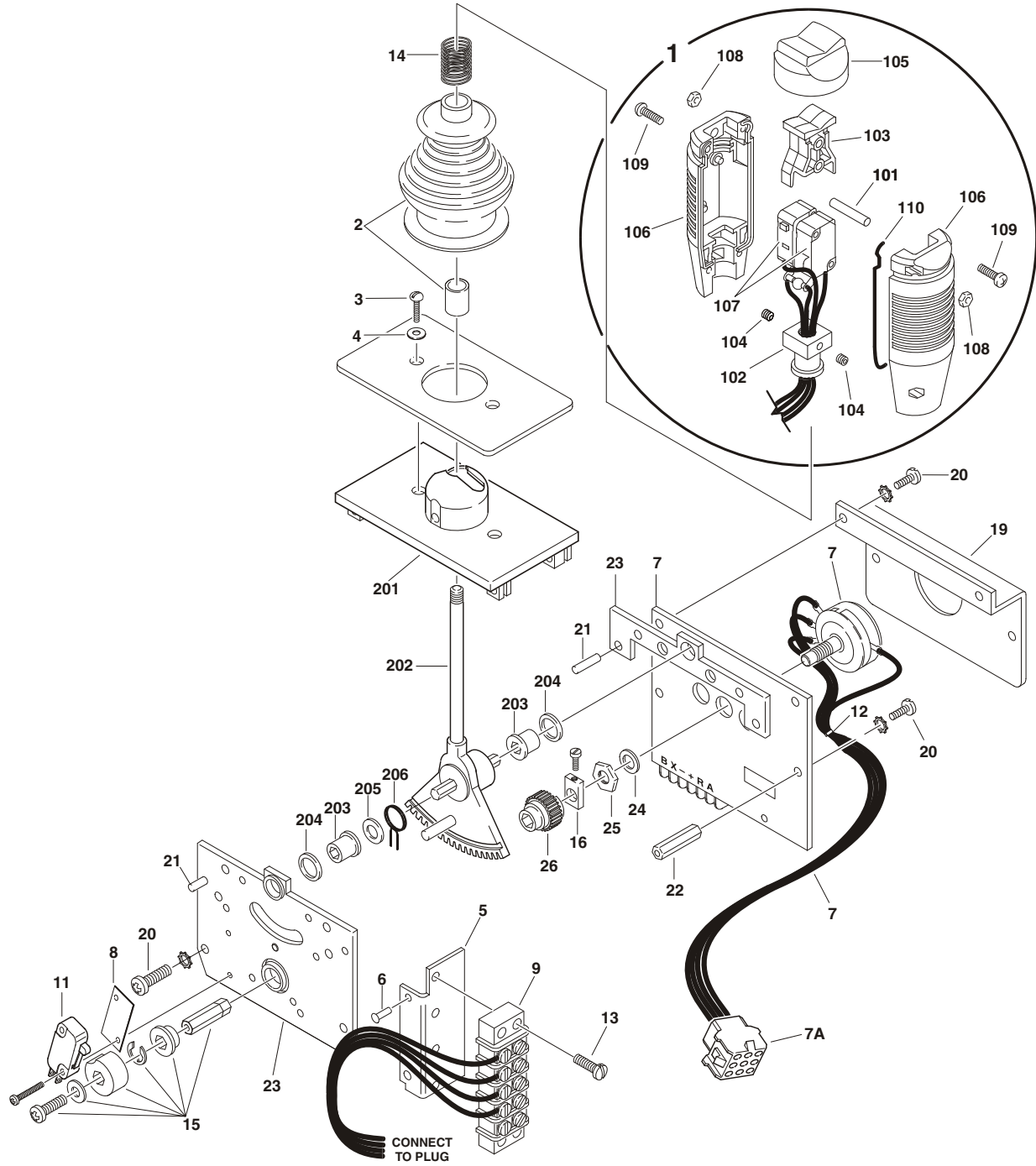

SECTION 4 PLATFORMS

# SECTION 4 PLATFORMS

**FIGURE 4-7. CONTROLLER ASSEMBLY (DRIVE & STEER)**

FIG & ITEM #	PART NUMBER	DESCRIPTION	QTY.	REV.
	1600287	<b>CONTROLLER ASSEMBLY</b>	Ref.	D
1	Not Available	Handle Assembly	1	
2	7019161	Boot and Sleeve	1	
3	7003969	Screw	2	
4	7003941	Washer	2	
5	7019159	Bracket, Mounting	1	
6	Not Serviced	Rivet	1	
7	7019124	Board, Circuit with Potentiometer	1	
7A	4460265	Plug - 9 Position (Part of Console Box Harness)	1	
	4460268	Socket, Female (Part of Console Box Harness)	9	
	4460266	Connector - 9 Position (Part of p/n 7019124)	1	
	4460267	Pin, Male (Part of p/n 7019124)	9	
8	7019138	Insulator	1	
9	7019153	Strip, Terminal - 5 Position	1	
10	7003938	Clamp, Boot (Not Shown)	1	
11	7003961	Microswitch	1	
12	7019151	Tie-Strap	3	
13	7003994	Screw	2	
14	7019162	Spring	1	
15	7019179	Micro Cam Assembly	1	
16	7019163	Potentiometer Coupling Assembly	1	
17	Not Used			
18	Not Used			
19	Not Serviced	Heatsink	1	
20	7019117	Screw	8	
21	7019103	Pin	4	
22	7019115	Stand-Off	2	
23	7019168	Plate, Mounting (Right Side)	1	
24	7003992	Washer	1	
25	7003993	Nut	1	
26	7003935	Gear, Slave	1	
		<b>HANDLE ASSEMBLY</b>	Ref.	
101	7019164	Axle	1	
102	7019194	Coupling	1	
103	7019165	Rocker	1	
104	7003983	Setscrew	2	
105	7003972	Boot, Switch	1	
106	7003973	Half, Handle	2	
107	7019166	Switch, Micro	1	
108	7019167	Nut	4	
109	7003980	Screw	4	
110	7003989	Gasket	2	

SECTION 4 PLATFORMS

# SECTION 4 PLATFORMS

**FIGURE 4-7. CONTROLLER ASSEMBLY (DRIVE & STEER) (CONTINUED)**

FIG & ITEM #	PART NUMBER	DESCRIPTION	QTY.	REV.
		<b>HANDLE ASSEMBLY</b>	Ref.	
201	7019160	Cast Housing Assembly	1	
202	7019155	Shaft 8mm	1	
203	7019111	Bearing	2	
204	7019110	Spacer, Head Gear	2	
205	7019112	Washer	1	
206	7003946	Spring, Return	1	

SECTION 4 PLATFORMS



# SECTION 4 PLATFORMS

FIGURE 4-7. CONTROLLER ASSEMBLY (DRIVE & STEER) (CONTINUED)

FIG & ITEM #	PART NUMBER	DESCRIPTION	QTY.	REV.

**S  
E  
C  
T  
I  
O  
N  
4  
P  
L  
A  
T  
F  
O  
R  
M  
S**

# SECTION 4 PLATFORMS

FIGURE 4-8. CONTROLLER ASSEMBLY (SPEED)

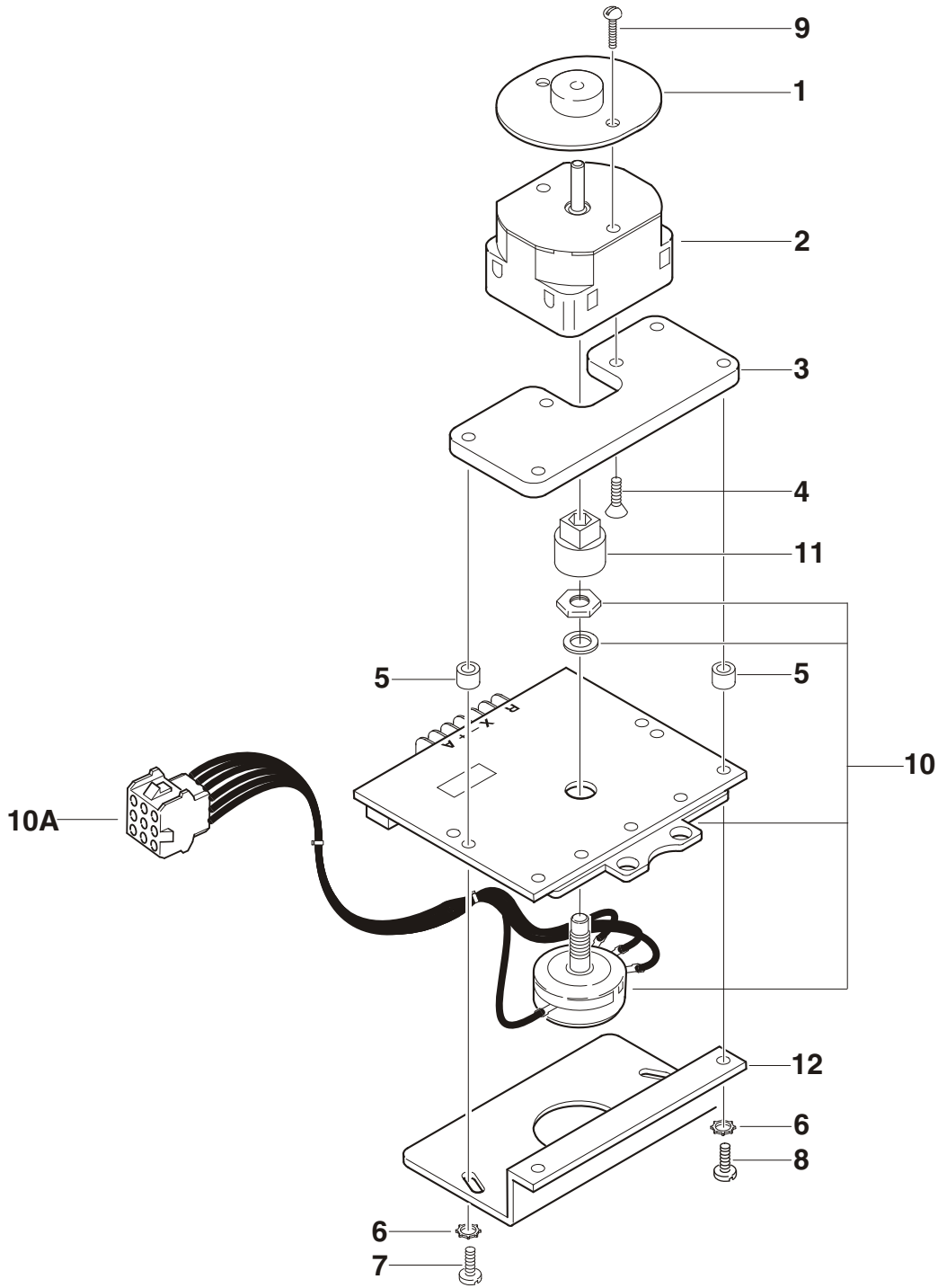

# SECTION 4 PLATFORMS

**FIGURE 4-8. CONTROLLER ASSEMBLY (SPEED)**

FIG & ITEM #	PART NUMBER	DESCRIPTION	QTY.	REV.
	1600272	<b>CONTROLLER ASSEMBLY</b>	Ref.	E
1	7019181	Seal	1	
2	7019182	Switch, Rotary	1	
3	Not Serviced	Plate	1	
4	7019183	Screw, Flathead	2	
5	7019184	Spacer	4	
6	7019135	Washer	4	
7	7019185	Screw	2	
8	7019186	Screw	2	
9	7019136	Screw	2	
10	7019187	Board, Circuit with Potentiometer	1	
10A	4460265	Plug - 9 Position (Part of Console Box Harness)	1	
	4460268	Socket, Female (Part of Console Box Harness)	9	
	4460266	Connector - 9 Position (Part of p/n 7019187)	1	
	4460267	Pin, Male (Part of p/n 7019187)	9	
11	7019188	Coupling, Potentiometer	1	
12	Not Serviced	Heatsink	1	

SECTION 4 PLATFORMS

# SECTION 4 PLATFORMS

FIGURE 4-9. SOFT TOUCH SYSTEM INSTALLATION

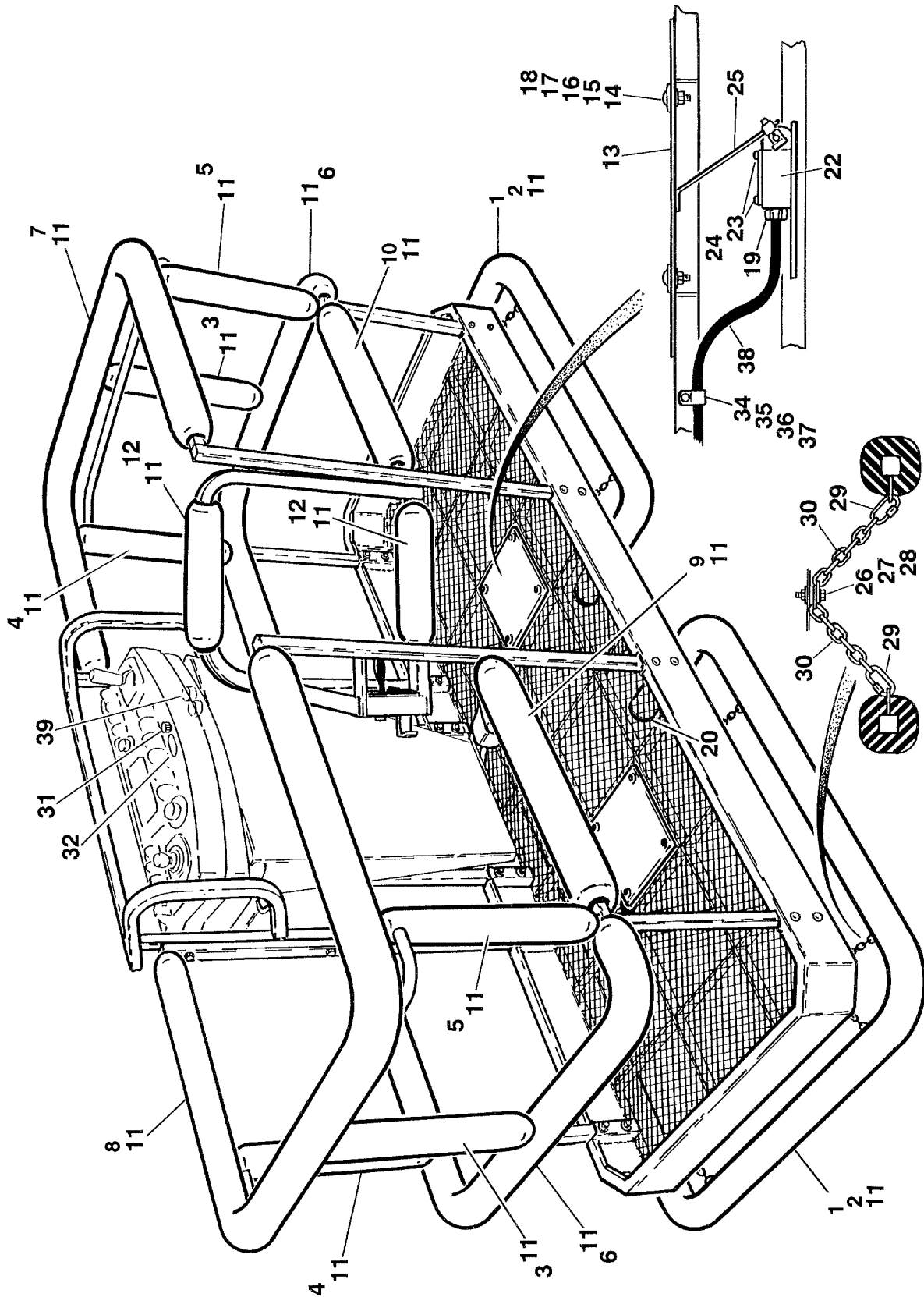

SECTION 4 PLATFORMS

# SECTION 4 PLATFORMS

**FIGURE 4-9. SOFT TOUCH SYSTEM INSTALLATION**

FIG & ITEM #	PART NUMBER	DESCRIPTION	QTY.	REV.
		<b>SOFT TOUCH SYSTEM INSTALLATIONS OPTIONS:</b>		
	0270318	<b>6Ft/1.8m Platforms</b>	Ref.	1
	0270312	<b>8Ft/2.4m Platforms</b>	Ref.	1
1		Rail Weldment Options:	2	
	4845308	6ft/1.8m Platforms		
	4845309	8Ft/2.4m Platforms		
2		Cover, Rail Options:	2	
	1670804	6ft/1.8m Platforms		
	1670803	8Ft/2.4m Platforms		
3	1670787	Cover, End Post	2	
4	1670785	Cover, Front Right Post	2	
5	1670786	Cover, Front Left Post	2	
6	1670793	Cover, End Mid Rail	2	
7		Cover, Right End Top Options:	1	
	1670798	6ft/1.8m Platforms		
	1670796	8Ft/2.4m Platforms		
8		Cover, Left End Top Options:	1	
	1670797	6ft/1.8m Platforms		
	1670795	8Ft/2.4m Platforms		
9		Cover, Left End Mid Options:	1	
	1670799	6ft/1.8m Platforms		
	1670789	8Ft/2.4m Platforms		
10		Cover, Right End Mid Options:	1	
	1670801	6ft/1.8m Platforms		
	1670791	8Ft/2.4m Platforms		
11	0940038	Padding, Bumper	70ft/21.4m	
12	1670788	Cover, Gate	2	
13	3539719	Plate, Switch Strike	2	
14	0630462	Bolt, Carriage	8	
15	4761500	Lockwasher 5/16"	8	
16	4751800	Flatwasher 1/2"	8	
17	3311501	Nut 5/16"-18NC	8	
18	4751500	Flatwasher 5/16"	8	
19	4460049	Connector, Strain Relief	2	
20	3530072	Plug, Cap	4	
21	Not Used			
22	4360057	Switch, Limit	2	
23	0731005	Bolt #10-32NC x 5/8"	4	
24	4751000	Lockwasher #10	4	
25	0200550	Arm, Switch	2	
26	0641612	Bolt 3/8"-16NC x 1 1/2"	8	
27	4751600	Flatwasher 3/8"	40	
28	3311605	Locknut 3/8"-16NC	8	
29	3010088	Link, Quick	16	
30	1260136	Chain	10ft/3m	
31	4360387	Switch, Push Button	1	
32	1702938	Decal - Soft Touch Override	1	
33	Not Used			

**SECTION 4 PLATFORMS**

# SECTION 4 PLATFORMS

**FIGURE 4-9. SOFT TOUCH SYSTEM INSTALLATION (CONTINUED)**

FIG & ITEM #	PART NUMBER	DESCRIPTION	QTY.	REV.
34	1320040	Clamp	4	
35	0641406	Bolt 1/4"-20NC x 3/4"	4	
36	4711400	Flatwasher 1/4"	8	
37	3311405	Locknut 1/4"-20NC	4	
38	1060330	Cable, Electrical - 16/3	16ft/4.9m	
39	4460425	Connector, Strain Relief Options:	1	

**SECTION 4 PLATFORMS**

# SECTION 5 CYLINDERS

## TABLE OF CONTENTS

FIGURE	DESCRIPTION	PAGE
5-1	AXLE EXTENSION CYLINDER ASSEMBLY .....	5-2
5-2	PLATFORM LEVEL CYLINDER ASSEMBLY .....	5-4
5-3	BOOM LIFT CYLINDER ASSEMBLY .....	5-6
5-4	EXTEND-A-REACH LEVEL CYLINDER ASSEMBLY.....	5-8
5-5	EXTEND-A-REACH LIFT CYLINDER ASSEMBLY.....	5-10
5-6	JACK CYLINDER ASSEMBLY .....	5-12
5-7	MASTER CYLINDER ASSEMBLY .....	5-14
5-8	STEER CYLINDER ASSEMBLY .....	5-16
5-9	TIE ROD CYLINDER ASSEMBLY .....	5-18
5-10	TELESCOPE CYLINDER ASSEMBLY .....	5-20

# SECTION 5 CYLINDERS

# SECTION 5 CYLINDERS

FIGURE 5-1. AXLE EXTENSION CYLINDER ASSEMBLY

SECTION 5 CYLINDERS

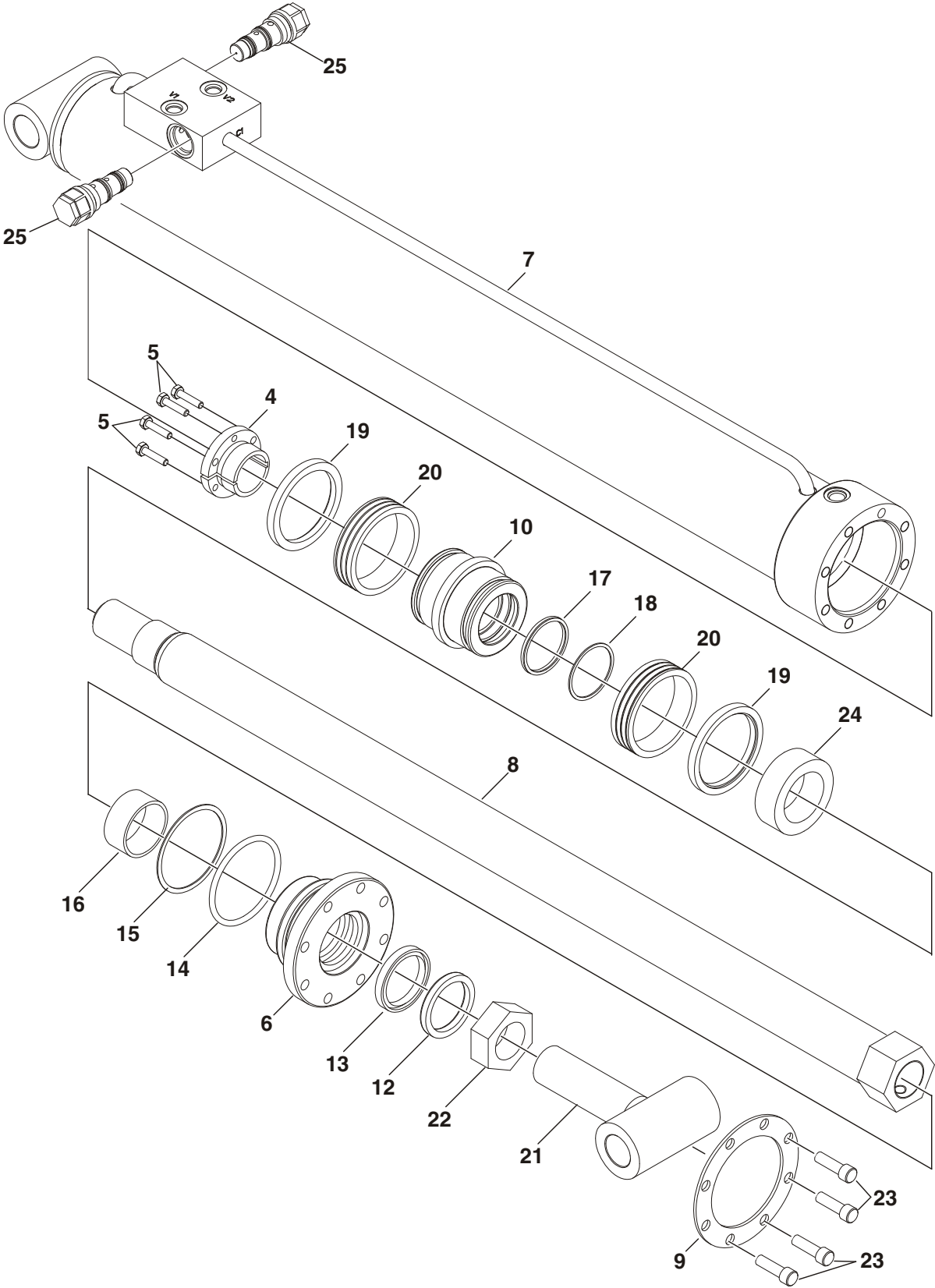



# SECTION 5 CYLINDERS

**FIGURE 5-1. AXLE EXTENSION CYLINDER ASSEMBLY**

FIG & ITEM #	PART NUMBER	DESCRIPTION	QTY.	REV.
	1683920	<b>AXLE EXTENSION CYLINDER ASSEMBLY</b>	Ref.	A
1	Not Used			
2	Not Used			
3	Not Used			
4	0961896	Bushing, Tapered	1	
5	0630535	Setscrew 1/4"-20NC x 1 1/8"	3	
6	1683056	Head	1	
7	1683915	Barrel Weldment	1	
8	1683918	Rod Weldment	1	
9	3760369	Ring, Washer	1	
10	3480218	Piston	1	
11	Not Used			
12	Kit	Wiper, Rod	1	
13	Kit	Seal, Rod	1	
14	Kit	O-Ring	1	
15	Kit	Ring, Back-Up	1	
16	Kit	Ring, Wear	1	
17	Kit	O-Ring	1	
18	Kit	Ring, Back-Up	2	
19	Kit	Ring, Lock	2	
20	Kit	Seal, Hydrolock	2	
21	3841466	Rod End Weldment	1	
22	3323402	Nut, Jam 1 1/2"-12NF	1	
23	3931620	Bolt 3/8"-16NC x 1 1/4"	8	
24	4568053	Spacer	1	
25	4640509	Cartridge, Holding Valve	2	
	2900792	Seal Kit - 4640509 Cartridge Valve (1 Per Valve)	2	
	0100038	Primer, Locking	A/R	
	0100011	Loctite #242	A/R	
	0100063	Loctite #609	A/R	
	2901353	Seal Kit (Includes Items 12-20)	1	

**SECTION 5 CYLINDERS**

# SECTION 5 CYLINDERS

FIGURE 5-2. PLATFORM LEVEL CYLINDER ASSEMBLY

SECTION 5 CYLINDERS

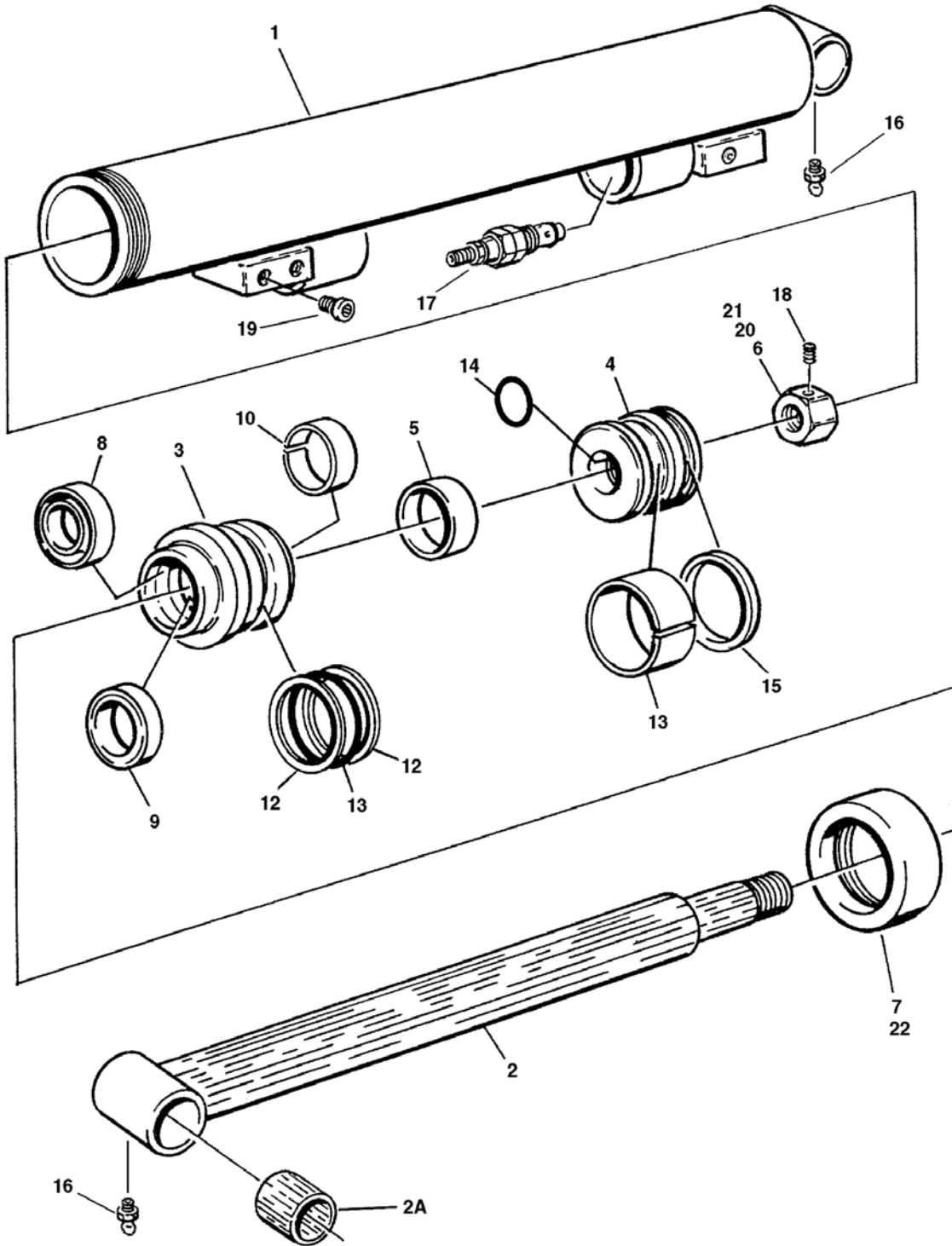

# SECTION 5 CYLINDERS

**FIGURE 5-2. PLATFORM LEVEL CYLINDER ASSEMBLY**

FIG & ITEM #	PART NUMBER	DESCRIPTION	QTY.	REV.
		<b>PLATFORM SLAVE LEVEL CYLINDER ASSEMBLY</b>	Ref.	
		<b>OPTIONS:</b>		
	1682590	<b>Prior To S/N 56302</b>	Ref.	C
	1683536	<b>S/N 56302 To Present</b>	Ref.	1/A
1		Barrel Assembly Options:	1	
	1682591	May 1992 to S/N 33111		
	1683535	S/N 33111 to Present		
2	1681974	Rod Assembly	1	
2A	0960097	Bushing	1	
3	1680892	Head	1	
4	3480120	Piston	1	
5	4564057	Spacer	1	
6	3300308	Nut	1	
7	1120179	Retainer	1	
8	Kit	Seal, Wiper	1	
9	Kit	Seal, Rod	1	
10	Kit	Ring, Wear	1	
11	Kit	O-Ring	1	
12	Kit	Ring, Back-up	2	
13	Kit	Ring, Wear	1	
14	Kit	O-Ring	1	
15	Kit	Seal, Piston	1	
16	2160002	Fitting, Grease	2	
17	4640634	Valve, Cartridge - Holding	2	
	2900770	Seal Kit - 4640634 Valve (1 Per Assembly)	1	
18	3900170	Setscrew 2/8"-16NC x 3/8"	1	
19	2220885	Plug, Socket Head #6	2	
20	0100011	Loctite #242	A/R	
21	0100038	Primer, Locking	A/R	
22	0100035	Loctite #222	A/R	
		-----		
	2900381	Seal Kit - 1682590 Cylinder (Includes Items 8-15)	1	

SECTION 5 CYLINDERS

# SECTION 5 CYLINDERS

FIGURE 5-3. BOOM LIFT CYLINDER ASSEMBLY

SECTION 5 CYLINDERS

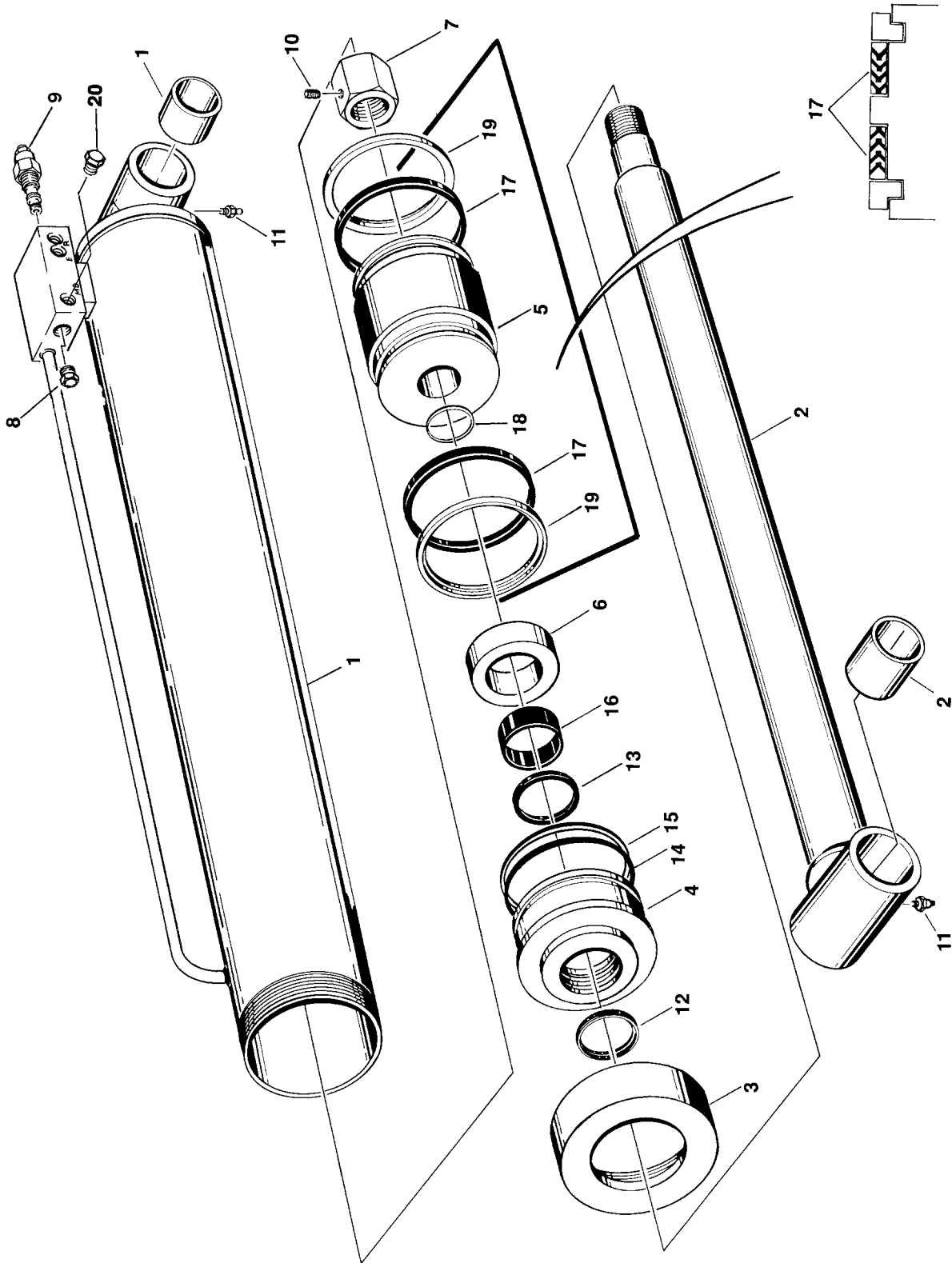

# SECTION 5 CYLINDERS

**FIGURE 5-3. BOOM LIFT CYLINDER ASSEMBLY**

FIG & ITEM #	PART NUMBER	DESCRIPTION	QTY.	REV.
		<b>BOOM LIFT CYLINDER ASSEMBLIES</b>	Ref.	
	1682895	<b>110SX/110SXJ/120SXJ</b>	Ref.	—
1	1682631	Barrel Weldment	1	
	0960509	Bushing, Bronze	2	
2	1682633	Rod Weldment	1	
	0961082	Bushing, Bronze	2	
3	1120363	Retainer	1	
4	1682118	Head	1	
5	3480162	Piston	1	
6	4565652	Spacer	1	
7	3300306	Nut	1	
8	2220887	Plug	1	
9	4640771	Cartridge, Holding Valve	1	
	2900770	Seal Kit - 4640709 Valve	1	
10	3900171	Setscrew 1/2"-13NC x 1/2"	1	
11	2160002	Fitting, Grease	2	
12	Kit	Wiper, Rod	1	
13	Kit	Seal, Rod	1	
14	Kit	O-Ring	1	
15	Kit	Ring, Back-Up	1	
16	Kit	Ring, Wear	1	
17	Kit	Ring, Guide	2	
18	Kit	O-Ring	1	
19	Kit	Ring, Lock	1	
20	2220883	Plug	1	
		-----		
	0100011	Loctite #242	A/R	
	0100038	Primer, Locking	A/R	
	0100035	Loctite #222	A/R	
		-----		
	2901118	Seal Kit (Includes Items 12-19)	1	

**SECTION 5 CYLINDERS**

# SECTION 5 CYLINDERS

FIGURE 5-4. EXTEND-A-REACH LEVEL CYLINDER ASSEMBLY

SECTION 5 CYLINDERS

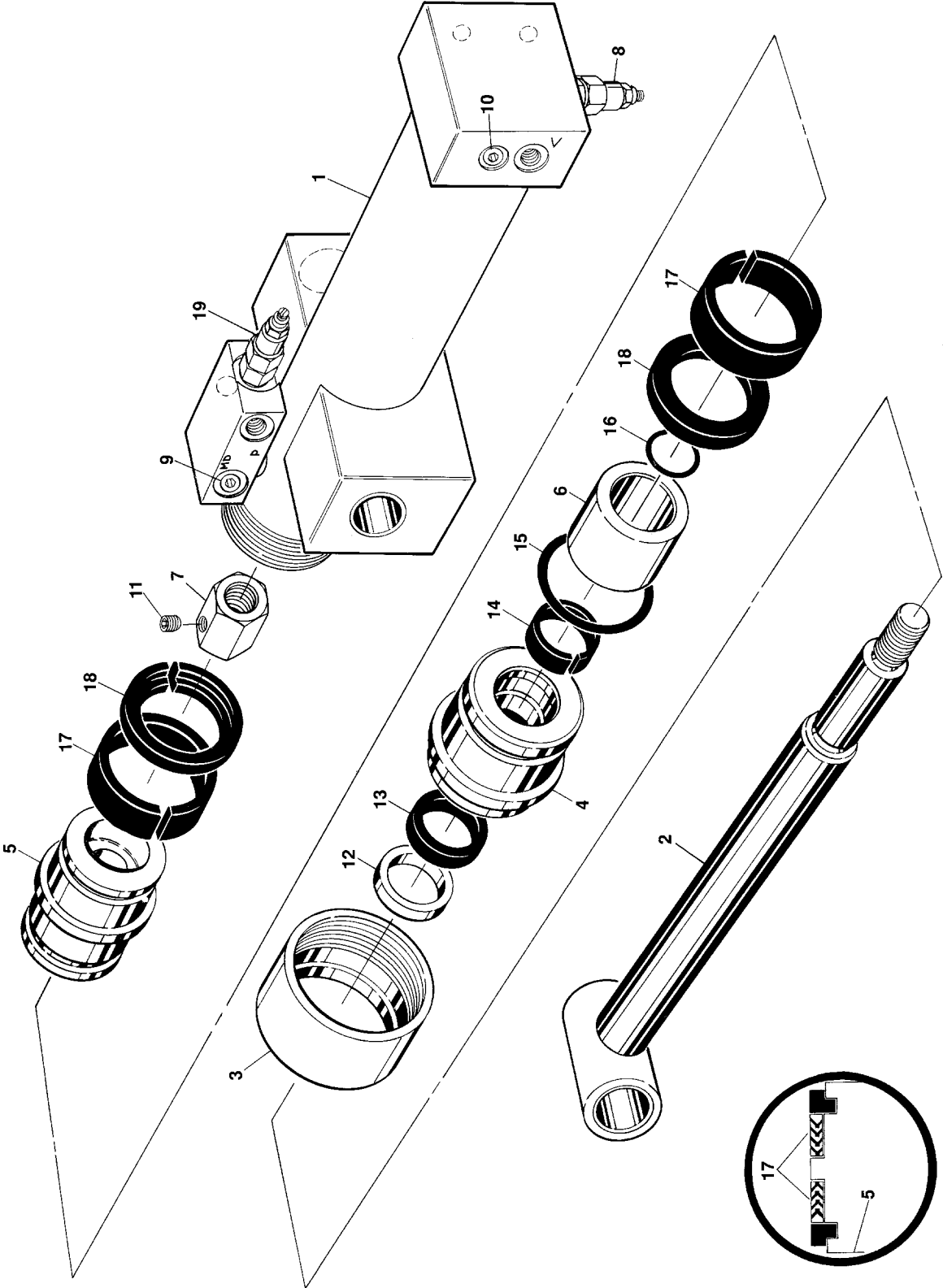

# SECTION 5 CYLINDERS

**FIGURE 5-4. EXTEND-A-REACH LEVEL CYLINDER ASSEMBLY**

FIG & ITEM #	PART NUMBER	DESCRIPTION	QTY.	REV.
	1683530	<b>EXTEND-A-REACH LEVEL CYLINDER ASSEMBLY</b>	Ref.	1/A
1	1683529	Barrel Weldment	1	
	0961595	Bushing, Bronze	2	
2	1682755	Rod Weldment	1	
	0961182	Bushing, Oilite	2	
3	1120305	Retainer	1	
4	1681792	Head	1	
5	3480167	Piston	1	
6	4565913	Spacer	1	
7	3300279	Nut	1	
8	4640634	Cartridge, Holding Valve	1	
	2900770	Seal Kit - 4640634 Valve	1	
9	2220885	Plug 3/8"	1	
10	2220883	Plug 1/4"	2	
11	3900170	Setscrew 3/8"-16NC x 3/8"	1	
12	Kit	Wiper, Rod	1	
13	Kit	Seal, Rod	1	
14	Kit	Ring, Wear	1	
15	Kit	O-Ring	1	
16	Kit	O-Ring	1	
17	Kit	Ring, Guide	2	
18	Kit	Ring, Lock	2	
19	4640996	Valve, Counterbalance	1	
	2900770	Seal Kit - 4640996 Valve	1	
	0100038	Primer, Loctite	A/R	
	0100011	Loctite #242	A/R	
	0100035	Loctite #222	A/R	
	2901206	Seal Kit (Includes Items 12-18)	1	

**SECTION 5 CYLINDERS**

# SECTION 5 CYLINDERS

FIGURE 5-5. EXTEND-A-REACH LIFT CYLINDER ASSEMBLY

SECTION 5 CYLINDERS

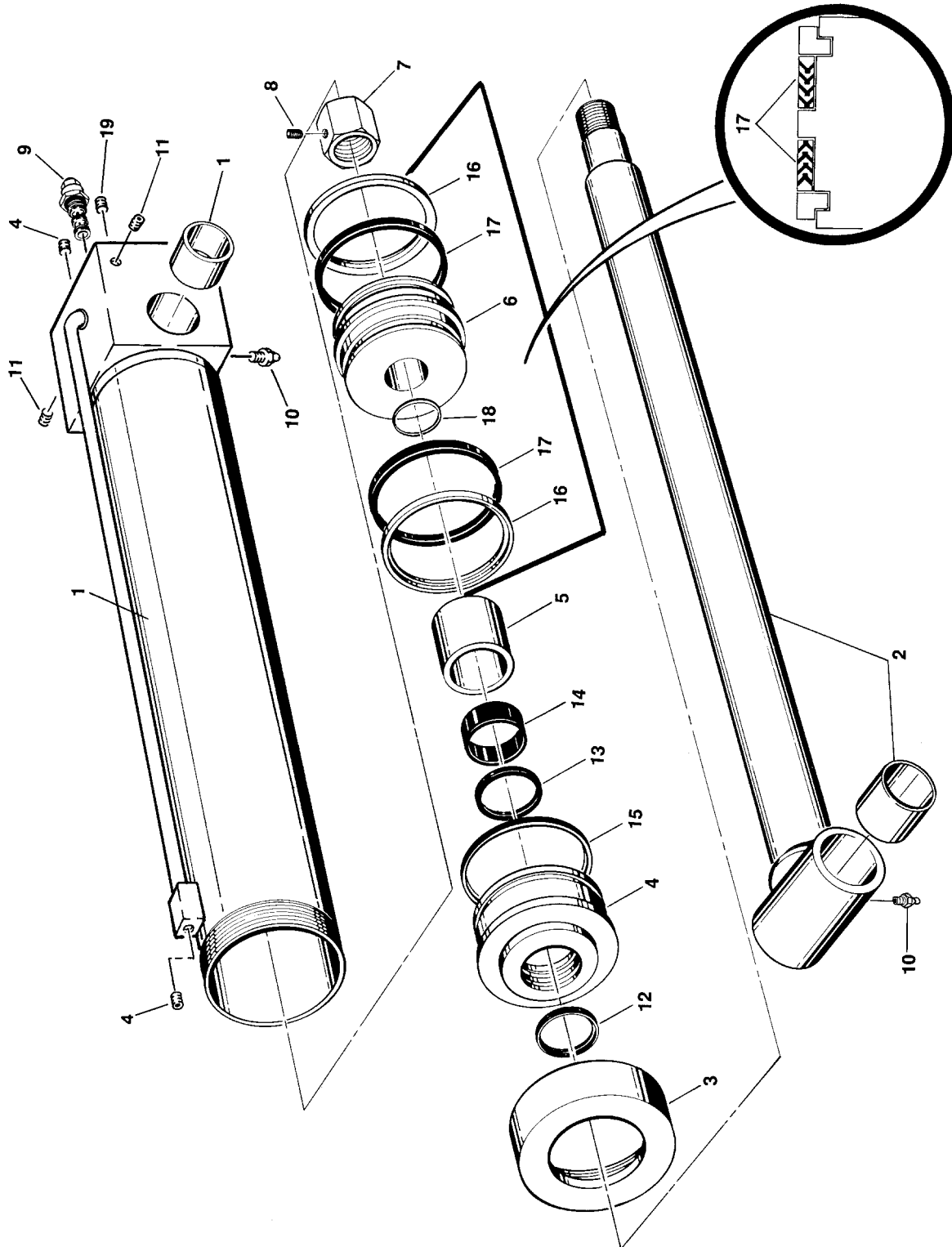



# SECTION 5 CYLINDERS

**FIGURE 5-5. EXTEND-A-REACH LIFT CYLINDER ASSEMBLY**

FIG & ITEM #	PART NUMBER	DESCRIPTION	QTY.	REV.
		<b>EXTEND-A-REACH LIFT CYLINDER ASSEMBLY OPTIONS:</b>		
	1683725	<b>Prior to S/N 64012</b>	Ref.	1
	1684164	<b>S/N 64012 to Present</b>	Ref.	1
1	1683724	Barrel Weldment	1	
	0961185	Bushing, Bronze	2	
2	1682638	Rod Weldment	1	
	0961595	Bushing, Bronze	2	
3	1120305	Retainer	1	
4	1681423	Head	1	
5	4564009	Spacer	1	
6	3480113	Piston	1	
7		Nut Options:	1	
	3300285	Prior to S/N 64012		
	3300307	S/N 64012 to Present		
8	3900170	Setscrew 3/8"-16NC x 3/8"	1	
9	4640495	Cartridge, Holding Valve	2	
	2900770	Seal Kit - 4640495 Valve (1 per Cartridge)	A/R	
10	2160002	Fitting, Grease	2	
11	2200201	Plug, Pipe 1/8" NPT	4	
12	Kit	Wiper, Rod	1	
13	Kit	Seal, Rod	1	
14	Kit	Ring, Wear	1	
15	Kit	Seal, Head	1	
16	Kit	Ring, Guide	2	
17	Kit	Ring, Lock	2	
18	Kit	O-Ring	1	
19	2200222	Plug, Pipe 1/4" NPT	2	
	0100020	Sealant, Pipe	A/R	
	0100011	Loctite #242	A/R	
	0100038	Primer, Locking	A/R	
	0100035	Loctite #222	A/R	
	2901142	Seal Kit (Includes Items 12-18)	1	

SECTION 5 CYLINDERS

# SECTION 5 CYLINDERS

FIGURE 5-6. JACK CYLINDER ASSEMBLY

SECTION 5 CYLINDERS

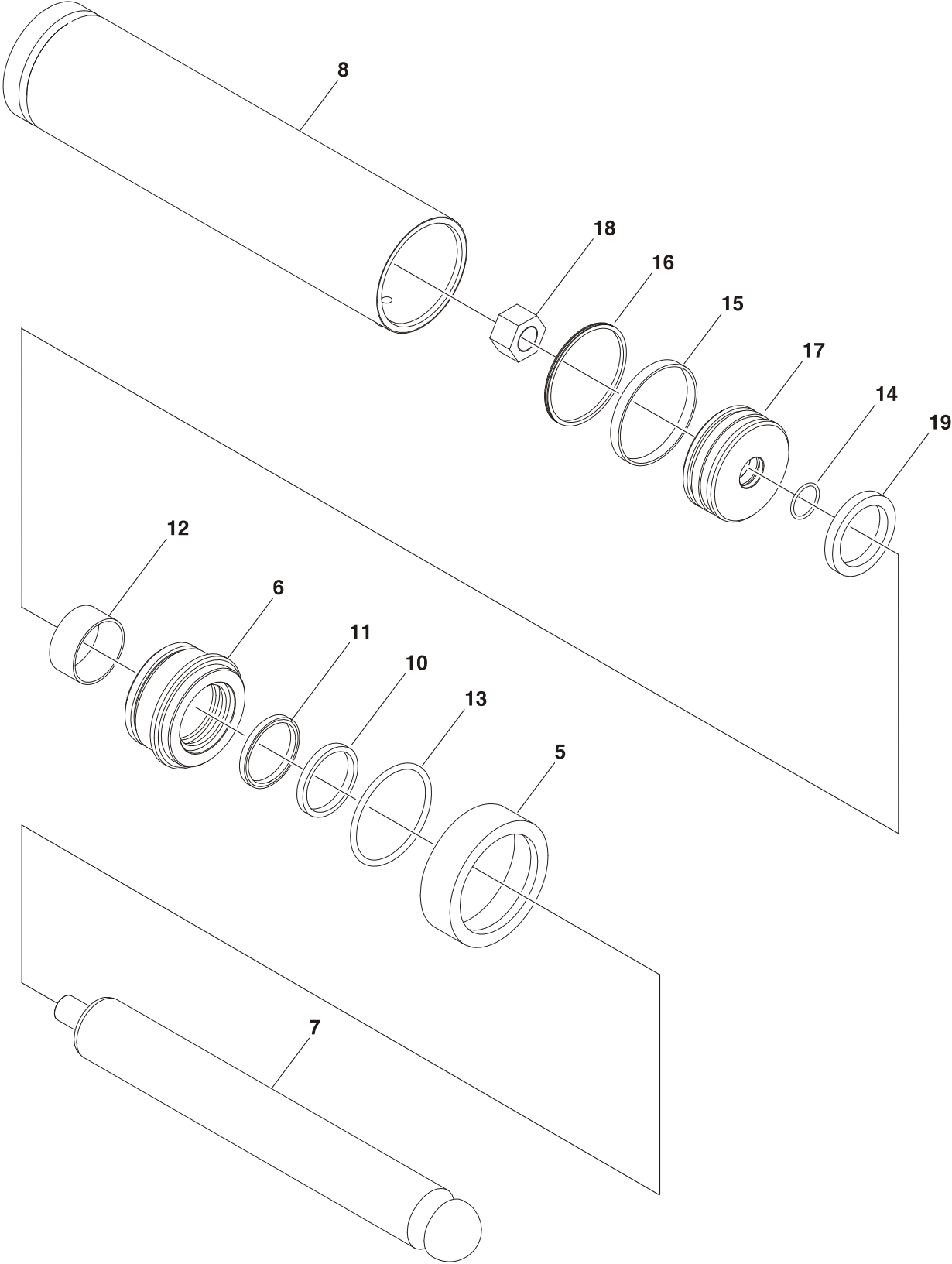

# SECTION 5 CYLINDERS

**FIGURE 5-6. JACK CYLINDER ASSEMBLY**

FIG & ITEM #	PART NUMBER	DESCRIPTION	QTY.	REV.
	1683965	<b>JACK CYLINDER ASSEMBLY</b>	Ref.	A
1 to 4	Not Used			
5	1120358	Retainer	1	
6	1682098	Head	1	
7	1682514	Rod Weldment	1	
8	1683964	Barrel Weldment	1	
9	Not Used			
10	Kit	Wiper, Rod	1	
11	Kit	Seal, Rod	1	
12	Kit	Ring, Wear	1	
13	Kit	O-Ring	1	
14	Kit	O-Ring	1	
15	Kit	Ring, Wear	1	
16	Kit	T-Seal	1	
17	3480137	Piston	1	
18	3300281	Nut	1	
19	4565225	Tube, Spacer	1	
		-----		
	0100011	Loctite #242	A/R	
	0100035	Primer, Locking	A/R	
	0100038	Loctite #222	A/R	
	0100063	Loctite #609	A/R	
		-----		
	2901115	Seal Kit (Includes Items 10-16)	1	

**SECTION 5 CYLINDERS**

# SECTION 5 CYLINDERS

FIGURE 5-7. MASTER CYLINDER ASSEMBLY

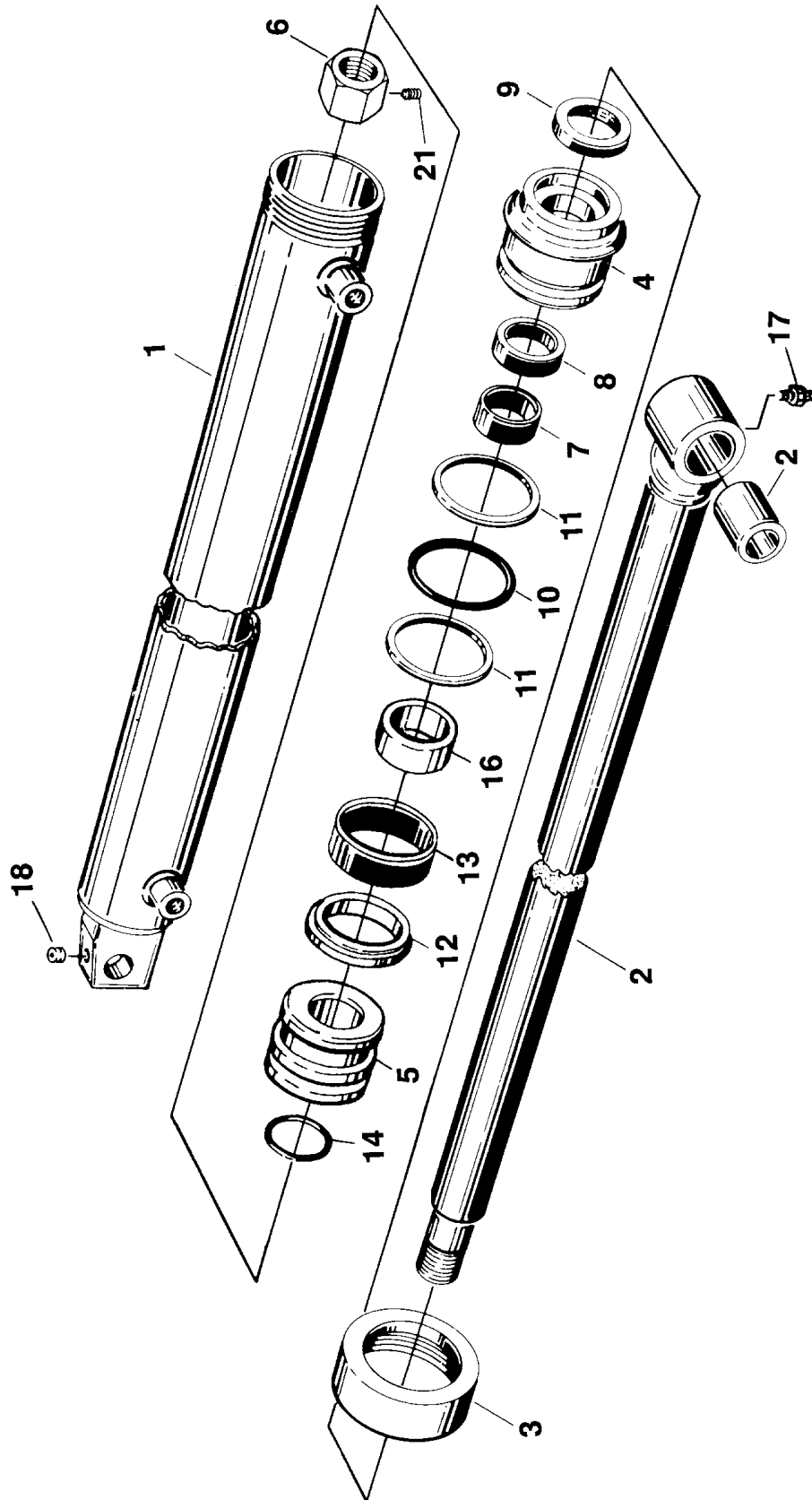

SECTION 5 CYLINDERS

# SECTION 5 CYLINDERS

**FIGURE 5-7. MASTER CYLINDER ASSEMBLY**

FIG & ITEM #	PART NUMBER	DESCRIPTION	QTY.	REV.
		<b>MASTER CYLINDER ASSEMBLIES</b>	Ref.	
	1681978	<b>100SX/110SX</b>	Ref.	C
	1681580	<b>110SXJ/120SXJ</b>	Ref.	F
1		Barrel Weldment	1	
	1681979	100SX/110SX		
	1681490	110SXJ/120SXJ		
2		Rod Weldment	1	
	1681974	100SX/110SX		
	1681488	110SXJ/120SXJ		
	0960097	Bushing, Bronze	1	
3	1120179	Retainer	1	
4	1680892	Head	1	
5	3480120	Piston	1	
6	3300272	Nut	1	
7	Kit	Ring, Wear	1	
8	Kit	Z-Seal	1	
9	Kit	Wiper, Rod	1	
10	Kit	O-Ring	1	
11	Kit	Ring, Back-Up	2	
12	Kit	Seal, Piston	1	
13	Kit	Ring, Wear	1	
14	Kit	O-Ring	1	
15	Not Used			
16		Tube, Spacer Options:	1	
	4564057	100SX/110SX		
	4563031	110SXJ/120SXJ		
17	2160002	Fitting, Grease	1	
18	2200201	Plug, Pipe 1/8" NPT	1	
19	Not Used			
20	Not Used			
21	3900170	Setscrew 3/8"-16NC x 3/8"	1	
		-----		
	0100011	Loctite #242	A/R	
	0100038	Primer, Locking	A/R	
	0100035	Loctite #222	A/R	
		-----		
	2900381	Seal Kit (Includes Items 7-14)	1	

**SECTION 5 CYLINDERS**

# SECTION 5 CYLINDERS

FIGURE 5-8. STEER CYLINDER ASSEMBLY

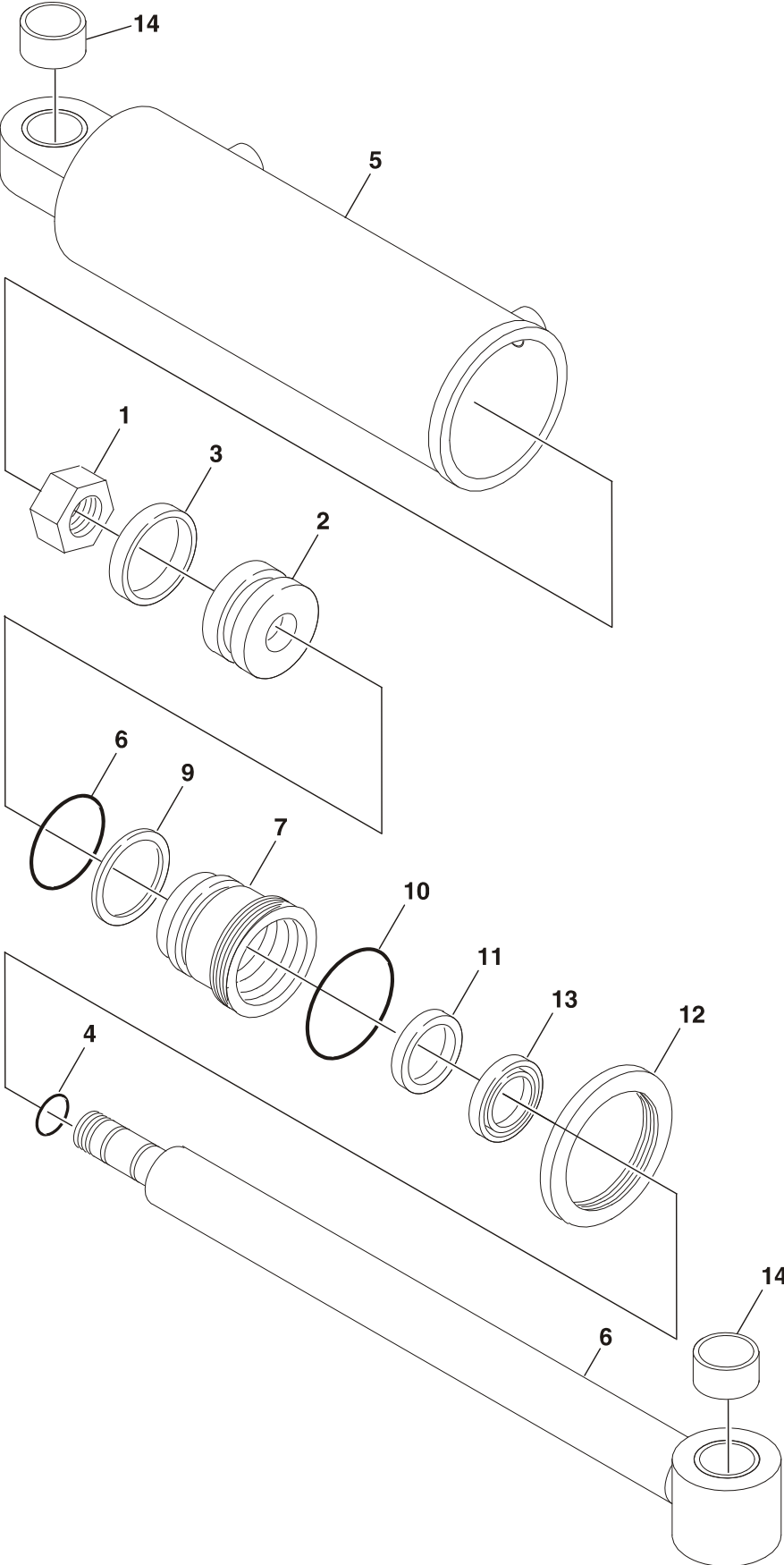

SECTION 5 CYLINDERS

# SECTION 5 CYLINDERS

**FIGURE 5-8. STEER CYLINDER ASSEMBLY**

FIG & ITEM #	PART NUMBER	DESCRIPTION	QTY.	REV.
		<b>STEER CYLINDER ASSEMBLIES</b>	Ref.	
	1683935	<b>2WS</b>	Ref.	D
	1683958	<b>4WS</b>	Ref.	B
1	7017278	Nut	1	
2	7023000	Piston	1	
3	Kit	Piston Seal	1	
4	Kit	O-Ring	1	
5		Barrel Weldment Options:	1	
	7023001	2WS		
	7023007	4WS		
6		Rod Weldment Options:	1	
	7023002	2WS		
	7023008	4WS		
7	7023003	Head	1	
8	Kit	O-Ring	1	
9	Kit	Ring, Back-Up	1	
10	Kit	Ring, Retainer	1	
11	Kit	Seal, Rod	1	
12	7023004	Spanner Nut	1	
13	Kit	Wiper, Rod	1	
14	0961951	Bushing	3	
		-----		
	7017299	Seal Kit (Includes Items 8-11 & 13)	1	

**SECTION 5 CYLINDERS**

# SECTION 5 CYLINDERS

FIGURE 5-9. TIE ROD CYLINDER ASSEMBLY

SECTION 5 CYLINDERS

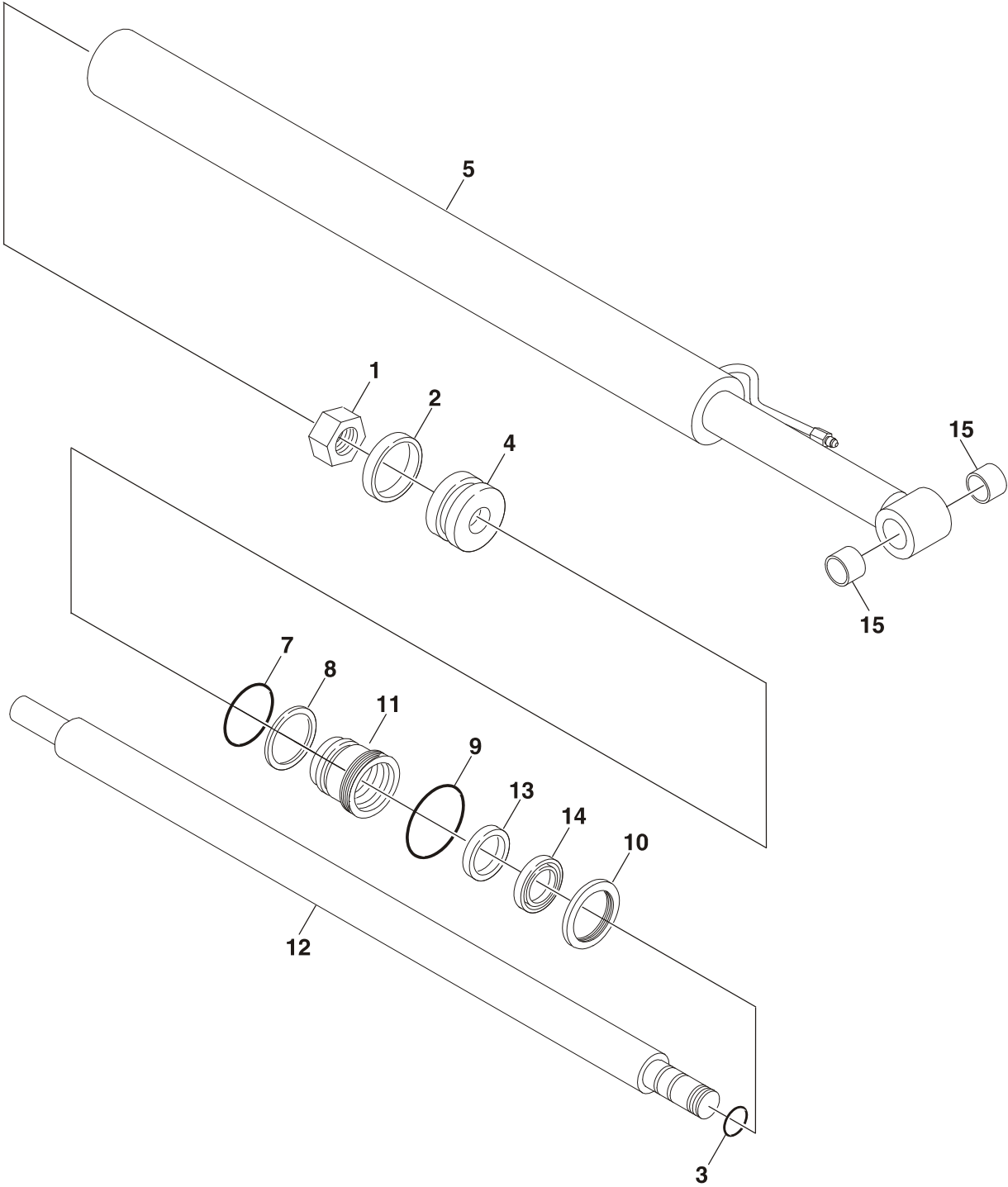



# SECTION 5 CYLINDERS

**FIGURE 5-9. TIE ROD CYLINDER ASSEMBLY**

FIG & ITEM #	PART NUMBER	DESCRIPTION	QTY.	REV.
	1683921	<b>TIE ROD CYLINDER ASSEMBLY</b>	Ref.	C
1	7017210	Nut	1	
2	Kit	Piston Seal	1	
3	Kit	O-Ring	1	
4	7017211	Piston	1	
5	7017296	Barrel Weldment	1	
6	Not Used			
7	Kit	O-Ring	1	
8	Kit	Ring, Back-Up	1	
9	Kit	O-Ring	1	
10	7017214	Spanner Nut	1	
11	7017297	Head	1	
12	7017298	Rod Weldment	1	
13	Kit	Seal, Rod	1	
14	Kit	Wiper, Rod	1	
15	0961951	Bushing, Garmax	2	
		-----		
	7017295	Seal Kit (Includes Items 2,3,7,8,9,13 & 14)	1	

**SECTION 5 CYLINDERS**

# SECTION 5 CYLINDERS

FIGURE 5-10. TELESCOPE CYLINDER ASSEMBLY

SECTIONS  
5  
CYLINDERS

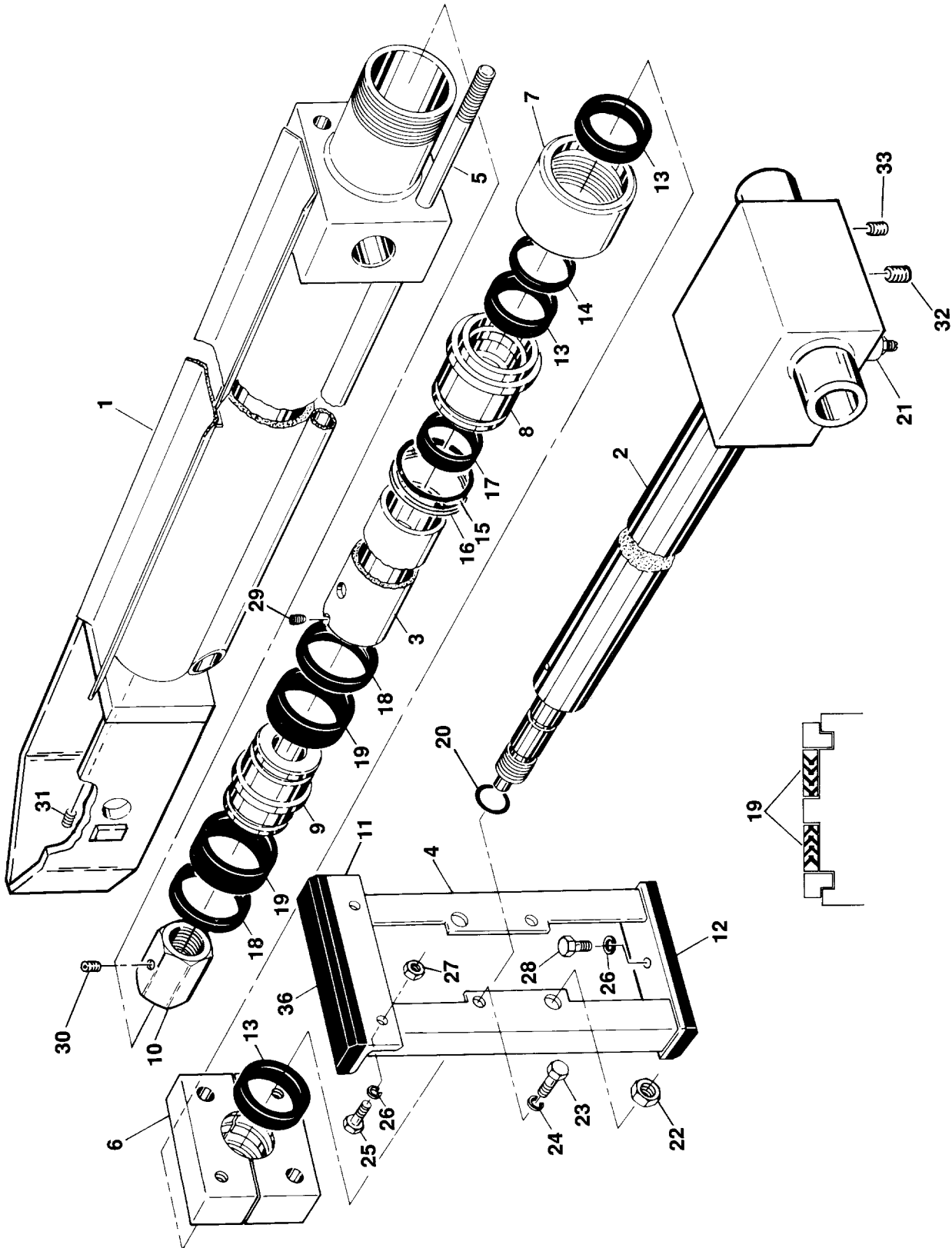

# SECTION 5 CYLINDERS

**FIGURE 5-10. TELESCOPE CYLINDER ASSEMBLY**

FIG & ITEM #	PART NUMBER	DESCRIPTION	QTY.	REV.
		<b>TELESCOPE CYLINDER ASSEMBLIES</b>	Ref.	
	1682820	<b>TELESCOPE CYLINDER ASSEMBLY - 110SX STANDARD - 110SX WITH INVERTED TRACK</b>	Ref.	A
	1682821	<b>TELESCOPE CYLINDER ASSEMBLY - 100SX/ 110SXJ &amp; 110SXJ WITH INVERTED TRACK</b>	Ref.	A
	1683701	<b>TELESCOPE CYLINDER ASSEMBLY - 120SXJ</b>	Ref.	2
1	1681926	Barrel Weldment	1	
2	1681922	Rod Weldment	1	
3	1682031	Spacer	1	
4	4843016	Rod Support Weldment	1	
5	3840944	Rod, Guide	2	
6	0560773	Block, Nylatron	1	
7	1120345	Retainer	1	
8	1682298	Head	1	
9	3480133	Piston	1	
10	3300299	Nut	1	
11	0181404	Angle	1	
12	3340560	Pad, Wear	1	
13	Kit	Seal, Rod	3	
14	Kit	Wiper, Rod	1	
15	Kit	O-Ring	1	
16	Kit	Ring, Back-Up	1	
17	Kit	Ring, Wear	1	
18	Kit	Ring, Guide	2	
19	Kit	Seal, Piston	2	
20	Kit	T-Seal	1	
21	4640487	Cartridge, Valve - With Inverted Track	1	
	4641083	Cartridge, Valve - Without Inverted Track	1	
22	3312202	Nut, Jam 3/4"-10NC	2	
23	0641812	Bolt 1/2"-13NC x 1 1/2"	2	
24	4761800	Lockwasher 1/2"	2	
25	0641608	Bolt 3/8"-16NC x 1"	2	
26	4761600	Lockwasher 3/8"	7	
27	3311601	Nut 3/8"-16NC	2	
28	0641605	Bolt 3/8"-16NC x 5/8"	5	
29	3951405	Setscrew 1/4"-20NC x 5/8"	1	
30	3900171	Setscrew 1/2"-13NC x 1/2"	1	
31	2200221	Plug, Pipe 1/8" NPT	1	
32	2200224	Plug, Pipe 3/8" NPT	2	
33	2200222	Plug, Pipe 1/4" NPT	1	
34 to 35	Not Used			
36	3340566	Pad, Wear	1	
	0100020	Sealant, Pipe	A/R	
	0100011	Loctite #242	A/R	
	0100035	Loctite #222	A/R	
	0100038	Primer, Locking	A/R	
	2901234	Seal Kit (Includes Items 13-20)	1	

SECTION 5 CYLINDERS

# SECTION 5 CYLINDERS

FIGURE 5-10. TELESCOPE CYLINDER ASSEMBLY (CONTINUED)

FIG & ITEM #	PART NUMBER	DESCRIPTION	QTY.	REV.

**S  
E  
C  
T  
I  
O  
N  
  
5  
  
C  
Y  
L  
I  
N  
D  
E  
R  
S**

# SECTION 6 HYDRAULICS

## TABLE OF CONTENTS

FIGURE	DESCRIPTION	PAGE
6-1	HYDRAULIC DIAGRAM - DRIVE (4WD - DEUTZ ENGINE) .....	6-2
6-2	HYDRAULIC DIAGRAM - T/T & BOOM .....	6-6
6-3	HYDRAULIC DIAGRAM - STEER .....	6-10
6-4	HYDRAULIC DIAGRAM - LIFTING JACKS .....	6-12
6-5	HYDRAULIC DIAGRAM LIST .....	6-14

# SECTION 6 HYDRAULICS

## FIGURE 6-1. HYDRAULIC DIAGRAM - DRIVE (4WD/DEUTZ ENGINE)

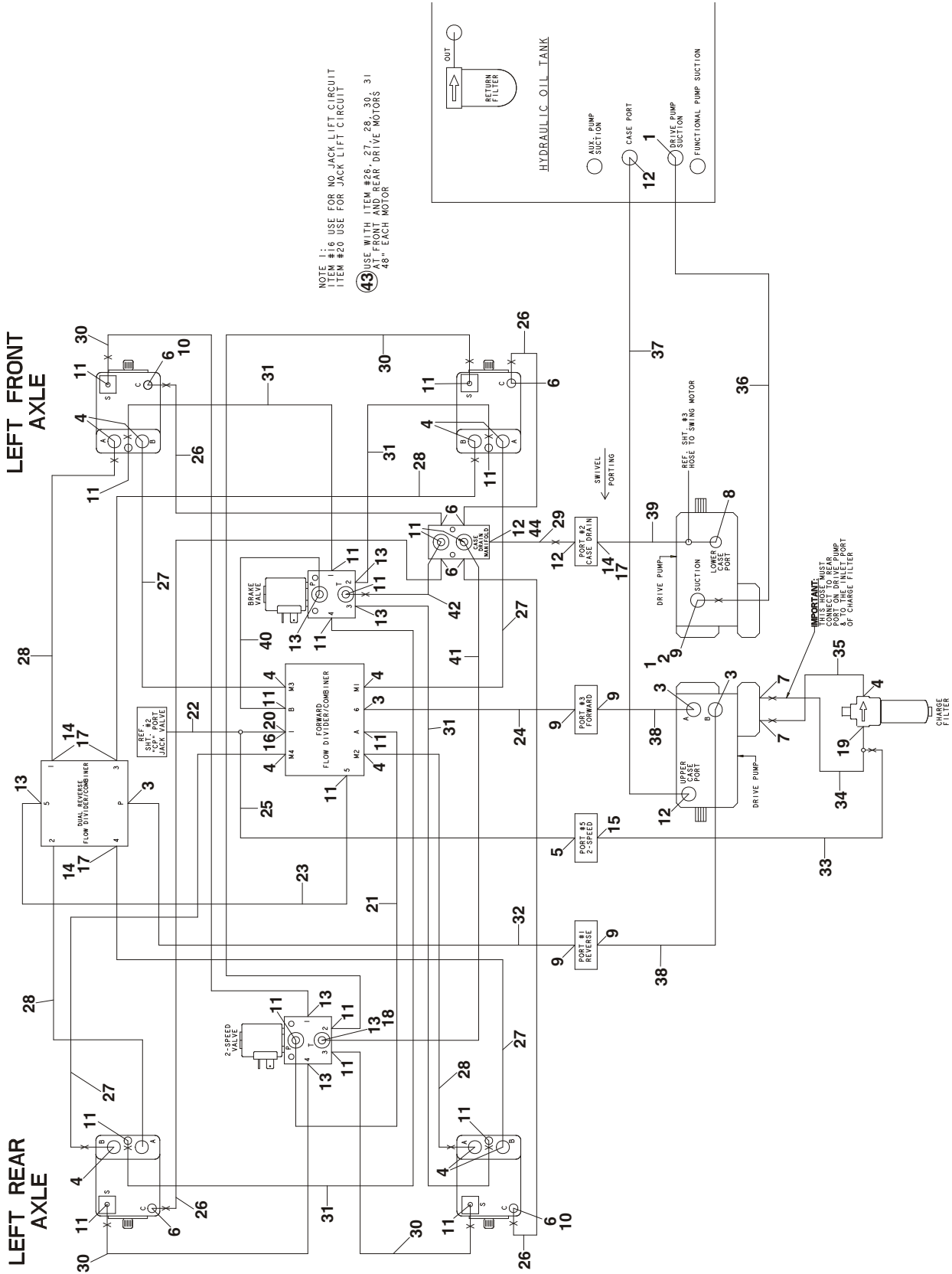

# SECTION 6 HYDRAULICS

**FIGURE 6-1. HYDRAULIC DIAGRAM - DRIVE (4WD/DEUTZ ENGINE)**

FIG & ITEM #	PART NUMBER	DESCRIPTION	QTY.	REV.
	2792433	<b>HYDRAULIC DIAGRAM - DRIVE</b>	Ref.	4
1	1320033	Clamp	2	
2	2210014	Fitting, 90° Barbed	1	
3	2220365	Fitting, 45°	4	
4	2220366	Fitting, 90°	13	
5	2220371	Fitting, Straight	1	
6	2220373	Fitting, Straight	8	
7	2220374	Fitting, Straight	2	
8	2221064	Fitting, Tee	1	
9	2220377	Fitting, Straight	5	
10	2220386	Fitting, 90°	2	
11	2220415	Fitting, Straight	19	
12	2220451	Fitting, Straight	5	
13	2220466	Fitting, 90°	7	
14	2220500	Fitting, 45°	5	
15	2220501	Fitting, 45°	1	
16	2220628	Fitting, 90°	1	
17	2220811	Fitting, Reducer	5	
18	2220909	Fitting, Orifice (.015)	1	
19	2221041	Fitting, Tee	1	
20	2221052	Fitting, Tee	1	
21	2752593	Hose	1	
22	2752473	Hose	1	
23	2753410	Hose	1	
24	2752322	Hose	1	
25	2752630	Hose	1	
26	2753483	Hose	4	
27	2753429	Hose	4	
28	2753432	Hose	4	
29		Hose Options:	1	
	2753316	Prior to S/N 55566		
	2753495	S/N 55566 to Present		
30	2753434	Hose	4	
31	2753423	Hose	4	
32	2753435	Hose	1	
33		Hose Options:	1	
	2753437	Prior to S/N 55566		
	2753509	S/N 55566 to Present		
34		Hose Options:	1	
	2752494	Prior to S/N 55566		
	2753510	S/N 55566 to Present		
35	2752498	Hose	1	
36	2720281	Hose, Suction	1	
37	2750835	Hose	1	
38	2752337	Hose	2	
39	2751484	Hose	1	
40	2752977	Hose	1	

# SECTION 6 HYDRAULICS

FIGURE 6-1. HYDRAULIC DIAGRAM - DRIVE (4WD/DEUTZ ENGINE)  
(CONTINUED)

FIG & ITEM #	PART NUMBER	DESCRIPTION	QTY.	REV.
41	2753035	Hose	1	
42	2752446	Hose	1	
43	4100059	Hose, Protection	16ft/4.9m	
44	2220407	Fitting, 90°	1	

**S  
E  
C  
T  
I  
O  
N  
  
6  
  
H  
Y  
D  
R  
A  
U  
L  
I  
C  
S**



# SECTION 6 HYDRAULICS

FIGURE 6-1. HYDRAULIC DIAGRAM - DRIVE (4WD/DEUTZ ENGINE)  
(CONTINUED)

FIG & ITEM #	PART NUMBER	DESCRIPTION	QTY.	REV.

**S  
E  
C  
T  
I  
O  
N  
  
6  
  
H  
Y  
D  
R  
A  
U  
L  
I  
C  
S**

# SECTION 6 HYDRAULICS

FIGURE 6-2. HYDRAULIC DIAGRAM - T/T & BOOM

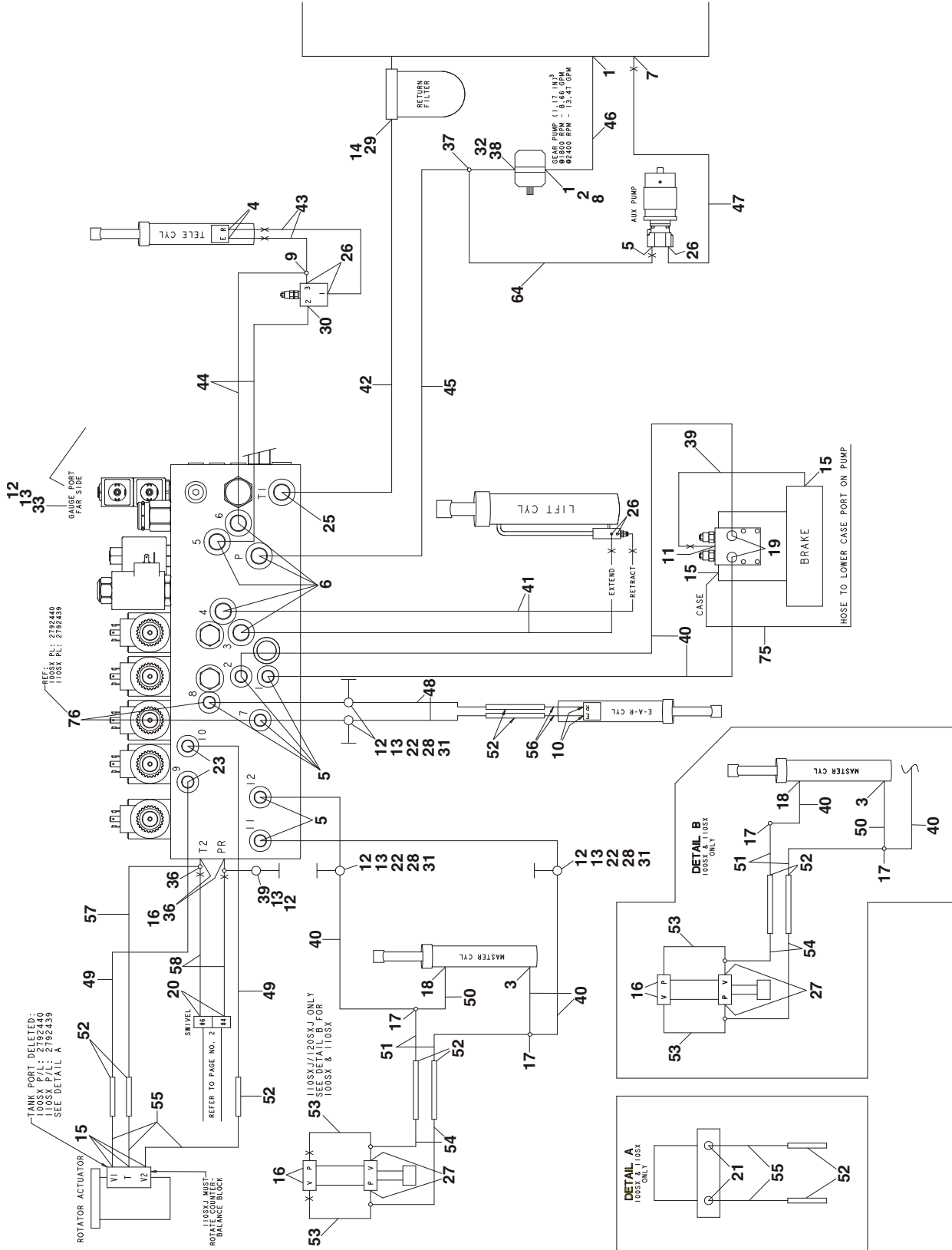

SC-FLUORHYD 6 NO-HOME

# SECTION 6 HYDRAULICS

**FIGURE 6-2. HYDRAULIC DIAGRAM - T/T & BOOM**

FIG & ITEM #	PART NUMBER	DESCRIPTION	QTY.	REV.
		<b>HYDRAULIC DIAGRAMS</b>	Ref.	
	2792440	<b>100SX</b>	Ref.	1
	2792439	<b>110SX</b>	Ref.	2
	2792438	<b>110SXJ</b>	Ref.	2
	2792437	<b>120SXJ</b>	Ref.	2
1	1320033	Clamp	A/R	
2	2210014	Fitting, 90°	1	
3	2220343	Fitting, Straight	1	
4	2220346	Fitting, Straight	2	
5	2220371	Fitting, Straight	A/R	
6	2220373	Fitting, Straight	5	
7	2220375	Fitting, Straight	1	
8	2220376	Fitting, Straight	A/R	
9	2220385	Fitting, Tee	1	
10		Fitting Options:	A/R	
	Not Required	110SX	0	
	2220399	100SX/110SXJ/120SXJ	2	
11	2220415	Fitting, Straight	1	
12	2220428	Fitting, Quick Disconnect	A/R	
13	2220429	Cap, Dust	A/R	
14	2220464	Fitting, 90°	1	
15	2220466	Fitting, 90°	A/R	
16	2220473	Fitting, 90°	A/R	
17	2220490	Fitting, Tee	2	
18	2220495	Fitting, 90°	1	
19	2220497	Fitting, Straight	A/R	
20	2220501	Fitting, 45°	2	
21		Fitting, 45°	A/R	
	2220502	100SX/110SX/110SXJ		
	Not Required	120SXJ		
22	2220438	Fitting, Nipple	A/R	
23	2220582	Fitting, Straight	2	
24	Not Used			
25	2220593	Fitting, Straight	1	
26	2220600	Fitting, Straight	5	
27	2220606	Fitting, Tee	A/R	
28	2220635	Fitting, Tee	A/R	
29	2220710	Fitting, Reducer	1	
30	2220726	Fitting, 90°	1	
31	2220741	Fitting, Adapter	A/R	
32	2220810	Fitting, Reducer	1	
33	2220873	Fitting, Nipple	1	
34 to 35	Not Used			
36		Fitting, Tee Options:	1	
	Not Required	110SX		
	2221065	100SX/110SXJ/120SXJ		
37	2221067	Fitting, Tee	1	
38	4640744	Valve, Check	1	

# SECTION 6 HYDRAULICS

**FIGURE 6-2. HYDRAULIC DIAGRAM - T/T & BOOM (CONTINUED)**

FIG & ITEM #	PART NUMBER	DESCRIPTION	QTY.	REV.
39	2750889	Hose	A/R	
40	2750785	Hose	5	
41	2750771	Hose	2	
42	2751617	Hose	1	
43	2751466	Hose	2	
44	2750763	Hose	2	
45	2751483	Hose	1	
46	2720281	Hose, Suction	1	
47	2751467	Hose	1	
48		Hose Options:	A/R	
	Not Required	110SX	0	
	2751168	100SX/110SXJ/120SXJ	2	
49	2751455	Hose	2	
50		Hose Options:	1	
	2750998	110SX (Prior to S/N 55566)		
	2750999	110SX (S/N 55566 to Present)		
	2752489	100SX/110SXJ/120SXJ		
51		Hose Options:	2	
	2751830	110SX/110SXJ		
	2751151	100SX/120SXJ		
52	4563167	Tube, Hydraulic	A/R	
53		Hose Options:	2	
	2751002	110SX (Prior to S/N 55566)		
	2750920	110SX (S/N 55566 to Present)		
	2751002	100SX/110SXJ/120SXJ		
54		Hose Options:	2	
	2752162	110SX (Prior to S/N 55566)		
	2751871	110SX (S/N 55566 to Present)		
	2752162	110SXJ		
	2752173	100SX/120SXJ		
55		Hose Options:	A/R	
	2750907	100SX	3	
	2751919	110SX	2	
	2753489	110SXJ	3	
	2753482	120SXJ	3	
56		Hose Options:	A/R	
	Not Required	110SX	0	
	2751170	110SXJ	2	
	2752172	100SX/120SXJ	2	
57		Hose Options:	A/R	
	Not Required	110SX	0	
	2753436	100SX/110SXJ/120SXJ	1	
58	2752637	Hose	2	
59 to 63	Not Used			
64	2752463	Hose	A/R	
65 to 74	Not Used			
75	2751906	Hose	1	

**SECTION 6 HYDRAULICS**

# SECTION 6 HYDRAULICS

**FIGURE 6-2. HYDRAULIC DIAGRAM - T/T & BOOM (CONTINUED)**

FIG & ITEM #	PART NUMBER	DESCRIPTION	QTY.	REV.
76	2220237	Plug Options:	A/R	
		100SX/110SX	2	
	Not Required	110SXJ/120SXJ	0	

**SECTION 6 HYDRAULICS**

# SECTION 6 HYDRAULICS

FIGURE 6-3. HYDRAULIC DIAGRAM - STEER

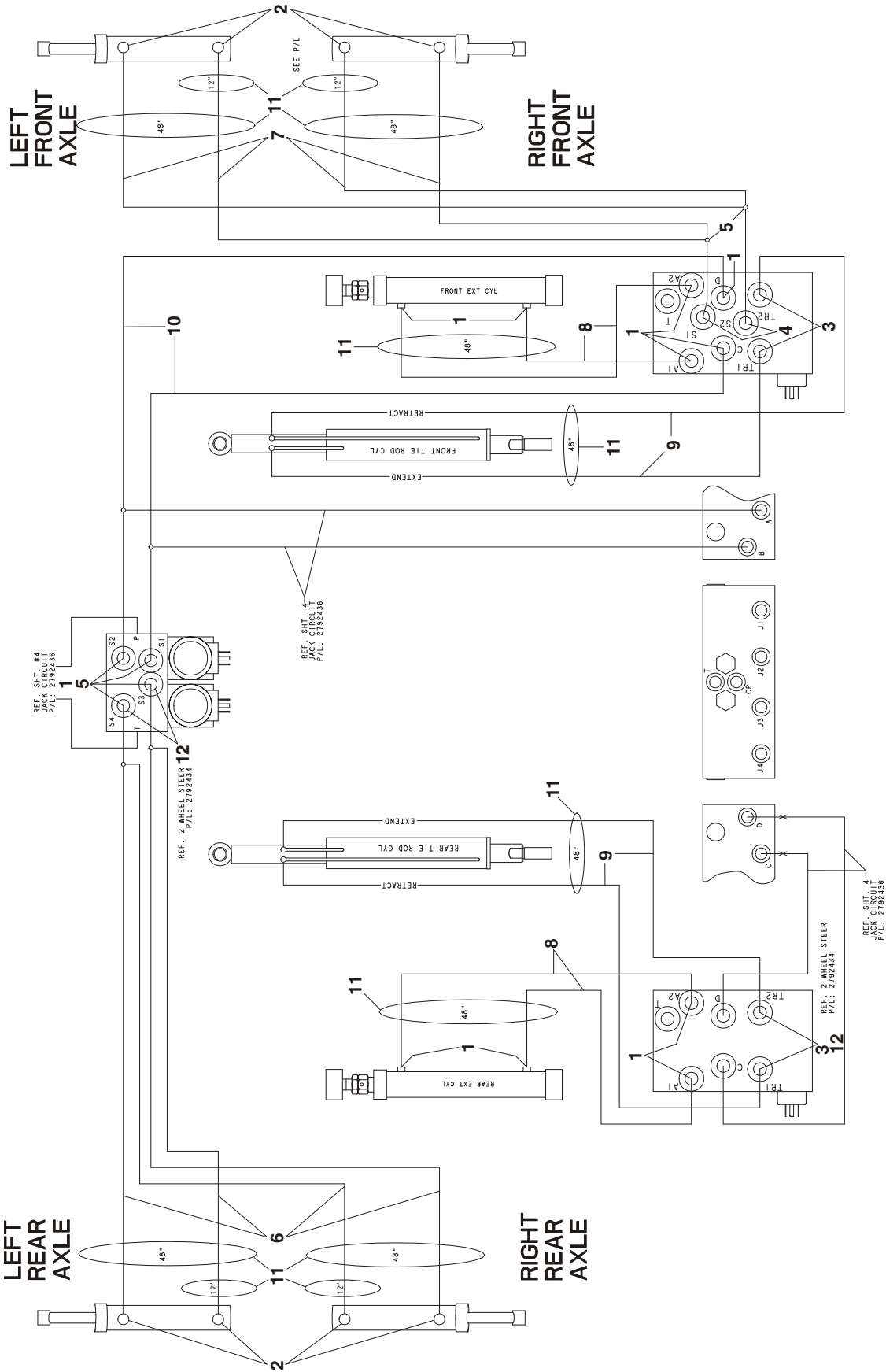

SECTION 6 HYDRAULICS

# SECTION 6 HYDRAULICS

**FIGURE 6-3. HYDRAULIC DIAGRAM - STEER**

FIG & ITEM #	PART NUMBER	DESCRIPTION	QTY.	REV.
		<b>HYDRAULIC DIAGRAMS</b>	Ref.	
	2792434	<b>2W/S</b>	Ref.	3
	2792435	<b>4W/S</b>	Ref.	3
1	2220371	Fitting, Straight	A/R	
2	2220473	Fitting, 90°	A/R	
3	2220582	Fitting, Straight	A/R	
4	2220998	Fitting, Straight	A/R	
5	2220635	Fitting, Tee	6	
6		Hose Options:	A/R	
	Not Required	2W/S	0	
	2753398	4W/S	4	
7	2753424	Hose	4	
8	2753426	Hose	4	
9	2753420	Hose	A/R	
10	2752480	Hose	2	
11		Hose, Protection Options:	A/R	
	4100026	2W/S	22.5ft/6.9m	
	4100026	4W/S	37ft/11.3m	
12		Plug Options:	A/R	
	2220237	2W/S	4	
	Not Required	4W/S	0	

**SECTION 6 HYDRAULICS**

# SECTION 6 HYDRAULICS

FIGURE 6-4. HYDRAULIC DIAGRAM - LIFTING JACKS

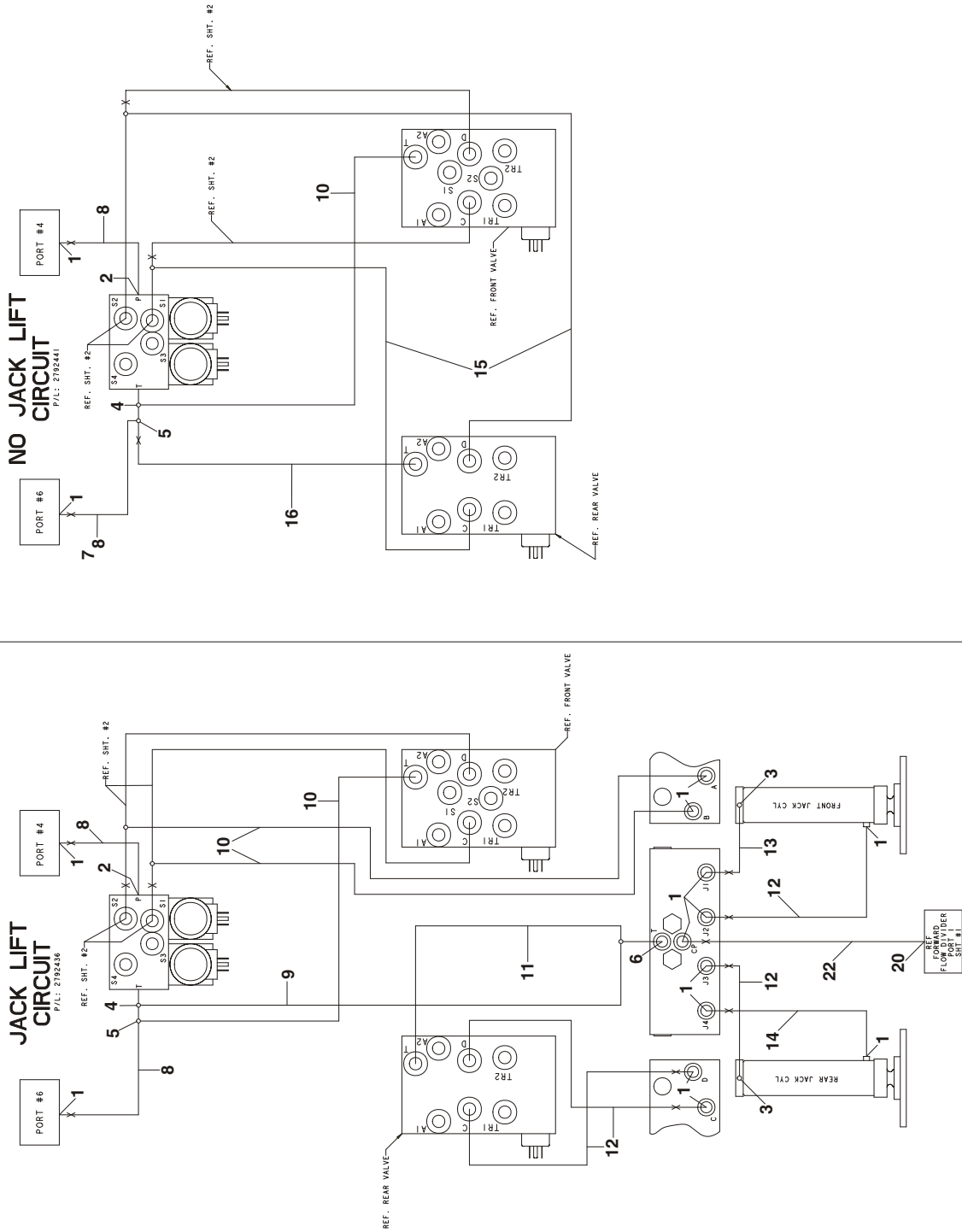



# SECTION 6 HYDRAULICS

**FIGURE 6-4. HYDRAULIC DIAGRAM - LIFTING JACKS**

FIG & ITEM #	PART NUMBER	DESCRIPTION	QTY.	REV.
	2792436	<b>HYDRAULIC DIAGRAM - WITH LIFTING JACKS</b>	Ref.	2
	2792441	<b>HYDRAULIC DIAGRAM - WITH OUT LIFTING JACKS</b>	Ref.	2
1	2220371	Fitting, Straight	A/R	
2	2220473	Fitting, 90°	1	
3	2220603	Fitting, Straight	2	
4	2220606	Fitting, Tee	1	
5	2220635	Fitting, Tee	A/R	
6		Fitting, Tee Options:	A/R	
	Not Required	With Out Lifting Jacks	0	
	2220899	With Lifting Jacks	1	
7	2752649	Hose (Prior to S/N 55566)	1	
8	2753397	Hose	2	
9		Hose Options:	A/R	
	Not Required	With Out Lifting Jacks	0	
	2752642	With Lifting Jacks	1	
10	2752480	Hose	A/R	
11		Hose Options:	A/R	
	Not Required	With Out Lifting Jacks	0	
	2752466	With Lifting Jacks	1	
12		Hose Options:	A/R	
	Not Required	With Out Lifting Jacks	0	
	2752462	With Lifting Jacks	4	
13		Hose Options:	A/R	
	Not Required	With Out Lifting Jacks	0	
	2752611	With Lifting Jacks	1	
14		Hose Options:	A/R	
	Not Required	With Out Lifting Jacks	0	
	2752484	With Lifting Jacks	1	
15		Hose Options:	A/R	
	2752475	With Out Lifting Jacks	2	
	Not Required	With Lifting Jacks	0	
16		Hose Options:	A/R	
	2752487	With Out Lifting Jacks	1	
	Not Required	With Lifting Jacks	0	

# SECTION 6 HYDRAULICS

**FIGURE 6-5. HYDRAULIC DIAGRAM LIST**

FIG & ITEM #	PART NUMBER	DESCRIPTION	QTY.	REV.
		<b>HYDRAULIC DIAGRAM LIST</b>	Ref.	
		<b>(Note: Diagrams with asterisk (*) are shown in previous pages. Information on diagrams not shown is available from JLG Service/Parts Departments.)</b>	Ref.	
	2792433/1283215*	<b>Hydraulic Diagram - Drive (4WD/ Deutz Engine)</b>	Ref.	
	2792440/1283215*	<b>Hydraulic Diagram - T/T &amp; Boom (100SX)</b>	Ref.	
	2792439/1283215*	<b>Hydraulic Diagram - T/T &amp; Boom (110SX)</b>	Ref.	
	2792438/1283215*	<b>Hydraulic Diagram - T/T &amp; Boom (110SXJ)</b>	Ref.	
	2792437/1283215*	<b>Hydraulic Diagram - T/T &amp; Boom (120SXJ)</b>	Ref.	
	2792434/1283215*	<b>Hydraulic Diagram - Steer (2W/S)</b>	Ref.	
	2792435/1283215*	<b>Hydraulic Diagram - Steer (4W/S)</b>	Ref.	
	2792436/1283215*	<b>Hydraulic Diagram - With Lifting Jacks</b>	Ref.	
	2792441/1283215*	<b>Hydraulic Diagram - With Out Lifting Jacks</b>	Ref.	
	2792447	<b>Hydraulic Schematic</b>	Ref.	

SECTION 6 HYDRAULICS

# SECTION 7 ELECTRICAL

## TABLE OF CONTENTS

FIGURE	DESCRIPTION	PAGE
7-1	ELECTRICAL DIAGRAM LIST .....	7-2
7-2	ELECTRICAL SCHEMATIC - 100SX/110SX .....	7-4
7-3	ELECTRICAL SCHEMATIC - 110SXJ .....	7-8
7-4	ELECTRICAL SCHEMATIC - 120SXJ .....	7-12
7-5	HARNESS COMPONENTS INSTALLATION .....	7-16

# SECTION 7 ELECTRICAL

**FIGURE 7-1.ELECTRICAL DIAGRAM LIST**

FIG & ITEM #	PART NUMBER	DESCRIPTION	QTY.	REV.
		<b>Note: Diagrams with asterisks (*) are not shown in the following pages. Diagrams not shown are available from the JLG Service Department.</b>	Ref.	
		<b>ALARM ELECTRICAL DIAGRAMS</b>		
	4932638/1282091	Motion Alarm	Ref.	2/C
	4932639/1282091	Travel Alarm	Ref.	2/C
	4933136	<b>BRAKE LIGHTS ELECTRICAL DIAGRAM</b>	Ref.	2/D
	0252928	<b>COLD WEATHER KIT WIRING DIAGRAM</b>	Ref.	F
	4922414	<b>ENGINE SHUTDOWN ELECTRICAL DIAGRAM</b>	Ref.	1/A
	4933137	<b>ENGINE SHUTDOWN ELECTRICAL DIAGRAM (BROKEN FAN BELT)</b>	Ref.	1/A
	4933139	<b>HEAD &amp; TAIL LIGHT ELECTRICAL DIAGRAM</b>	Ref.	2/C
	0270834	<b>LOW ENGINE OIL PRESSURE SHUTDOWN ELECTRICAL DIAGRAM</b>	Ref.	1/A
	1281814	<b>OIL COOLER ELECTRICAL DIAGRAM</b>	Ref.	A
	4922418	<b>PLATFORM ELECTRICAL DIAGRAM</b>	Ref.	4/D
	4933138	<b>PLATFORM SOFT TOUCH WIRING DIAGRAM</b>	Ref.	1/A
	0258048	<b>PLATFORM WORKLIGHTS ELECTRICAL DIAGRAM</b>	Ref.	2/E
	0270048	<b>REMOTE DRIVE ELECTRICAL DIAGRAM</b>	Ref.	2/C
		<b>STANDARD ELECTRICAL DIAGRAMS</b>		
	4933142	100SX/110SX	Ref.	5/G
	4933141	110SXJ	Ref.	6/H
	4933140	120SXJ	Ref.	6/H
		<b>STANDARD ELECTRICAL SCHEMATICS</b>		
	1870125*	100SX/110SX	Ref.	D
	1870124*	110SXJ	Ref.	D
	1870123*	120SXJ	Ref.	D
	1283193	<b>STROBE LIGHT ELECTRICAL DIAGRAM</b>	Ref.	B

**SECTION 7 ELECTRICAL**

# SECTION 7 ELECTRICAL

FIGURE 7-1.ELECTRICAL DIAGRAM LIST (Continued)

FIG & ITEM #	PART NUMBER	DESCRIPTION	QTY.	REV.

**S  
E  
C  
T  
I  
O  
N  
  
7  
  
E  
L  
E  
C  
T  
R  
I  
C  
A  
L**

# SECTION 7 ELECTRICAL

FIGURE 7-2.ELECTRICAL SCHEMATIC - 100SX/110SX

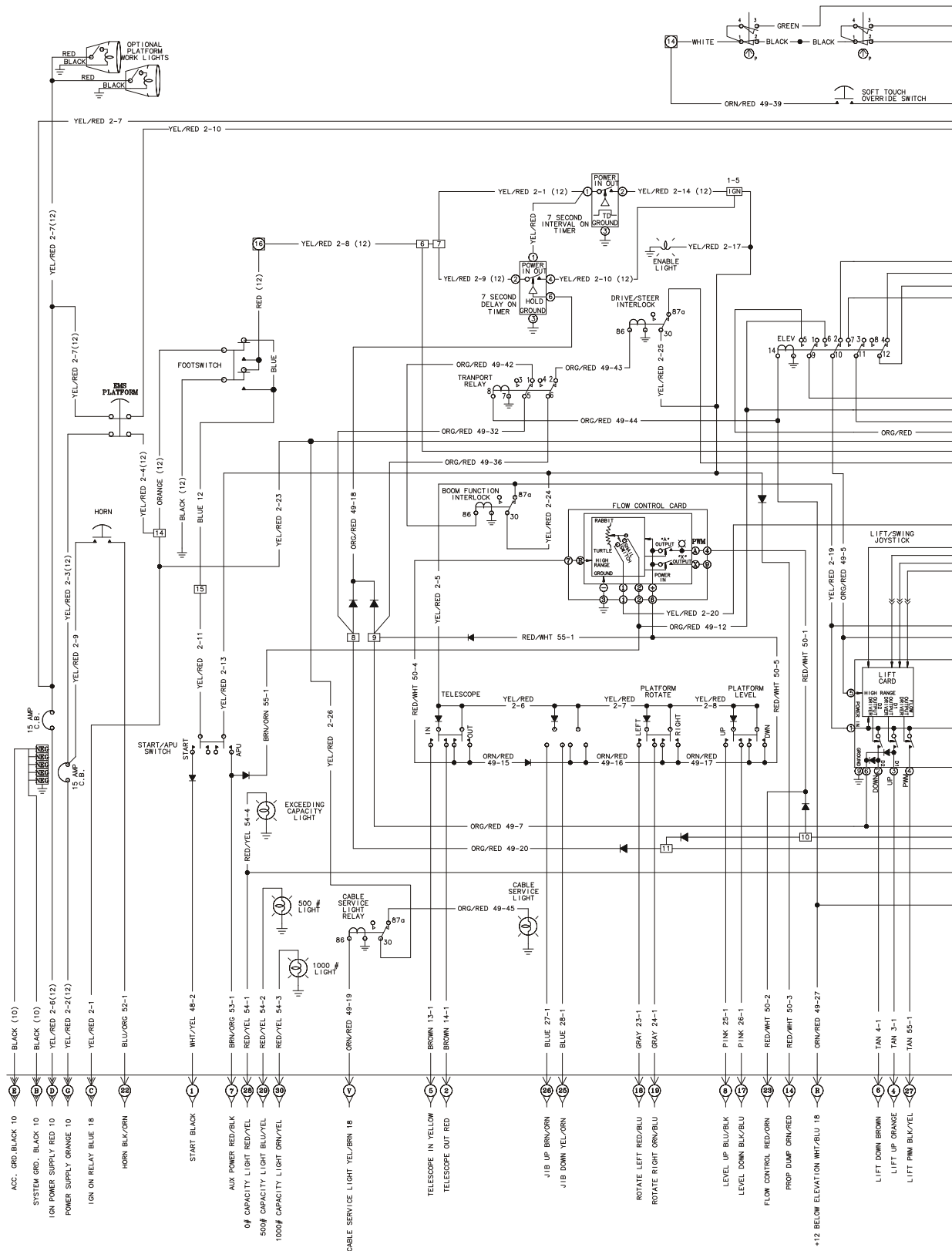

SECTION 7 ELECTRICAL

# SECTION 7 ELECTRICAL

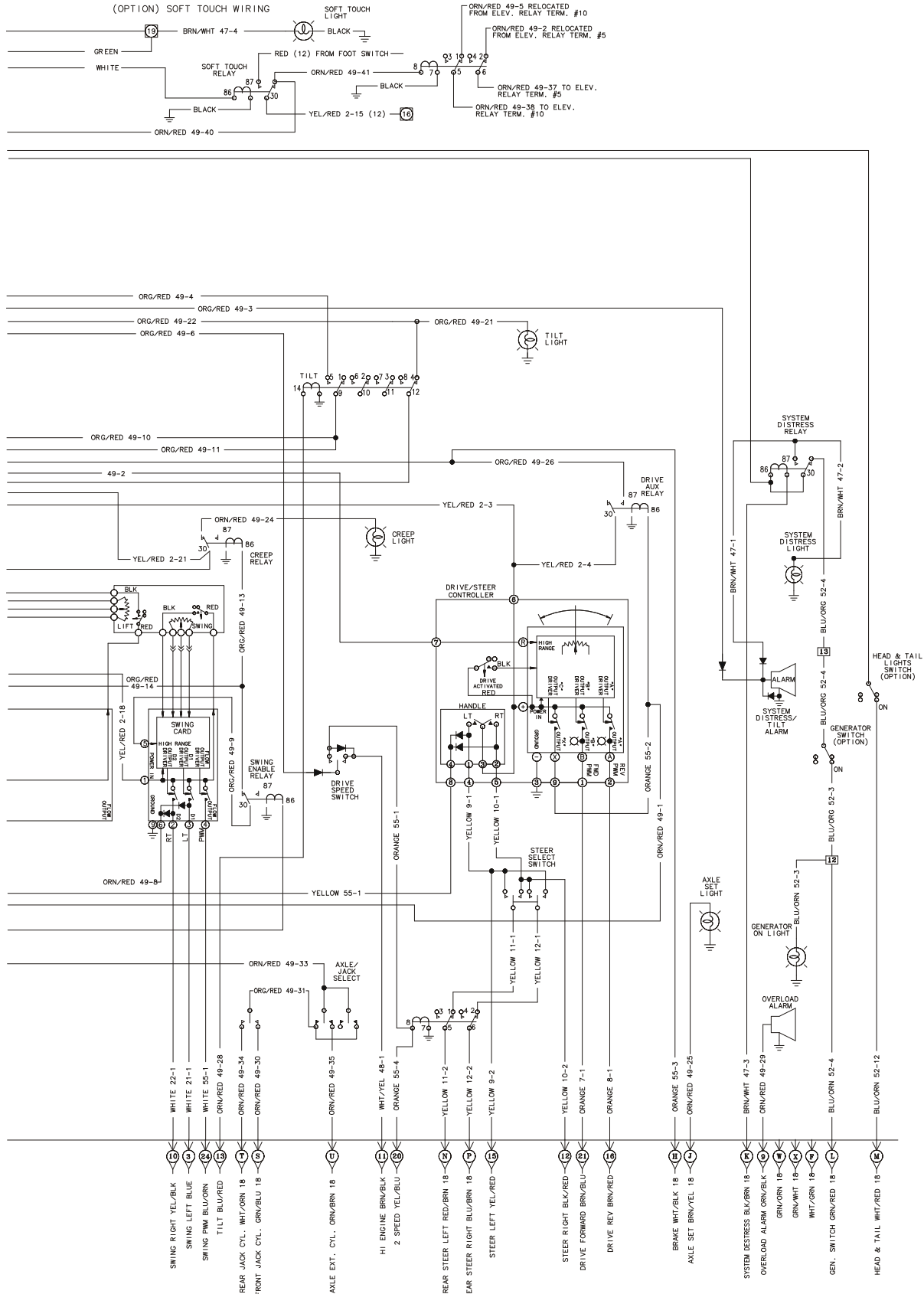

SECTION 7 ELECTRICAL

1870125\_D

# SECTION 7 ELECTRICAL

**Figure 7-2. ELECTRICAL SCHEMATIC - 100SX/110SX**

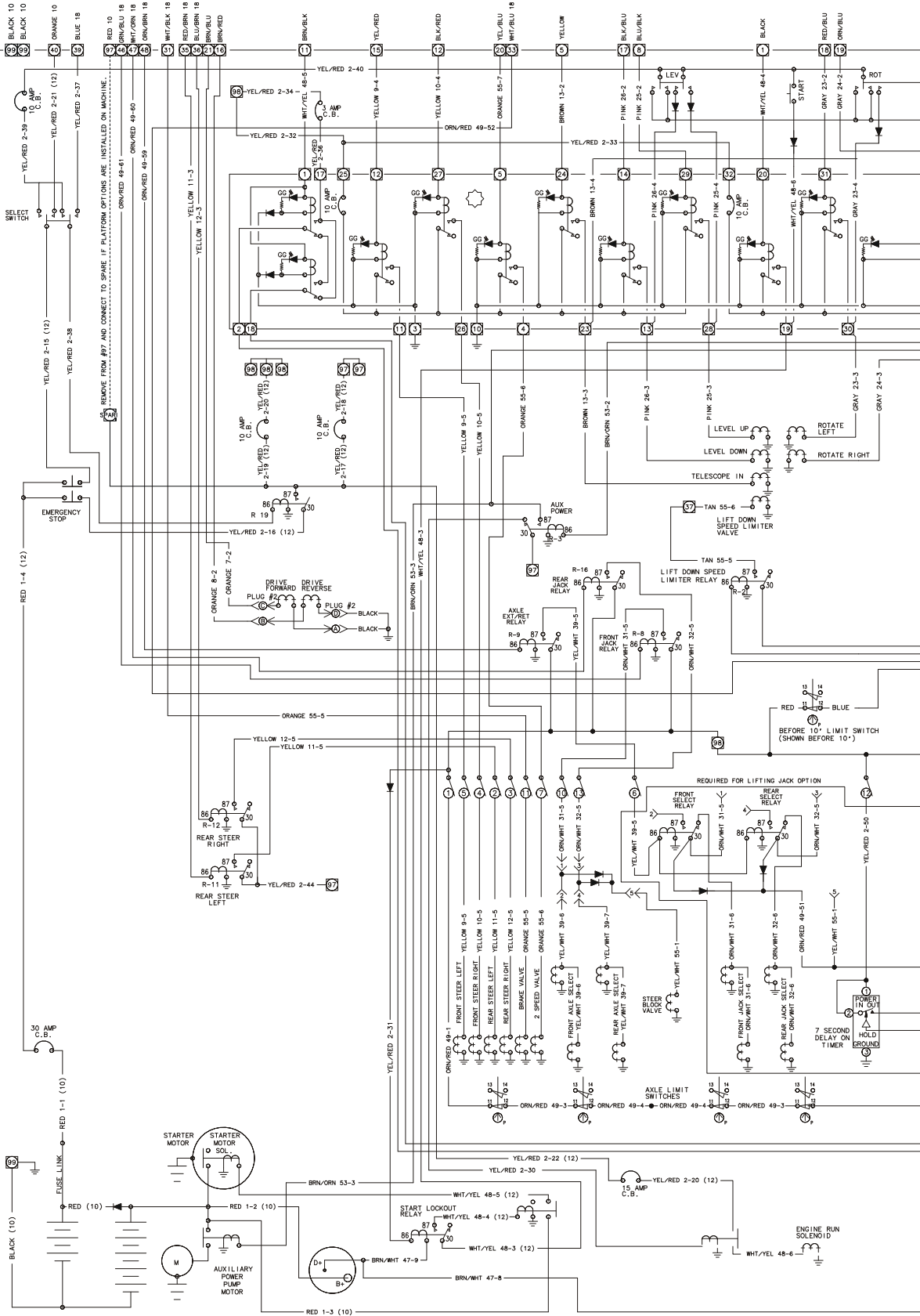

SECTION 7 ELECTRICAL



# SECTION 7 ELECTRICAL

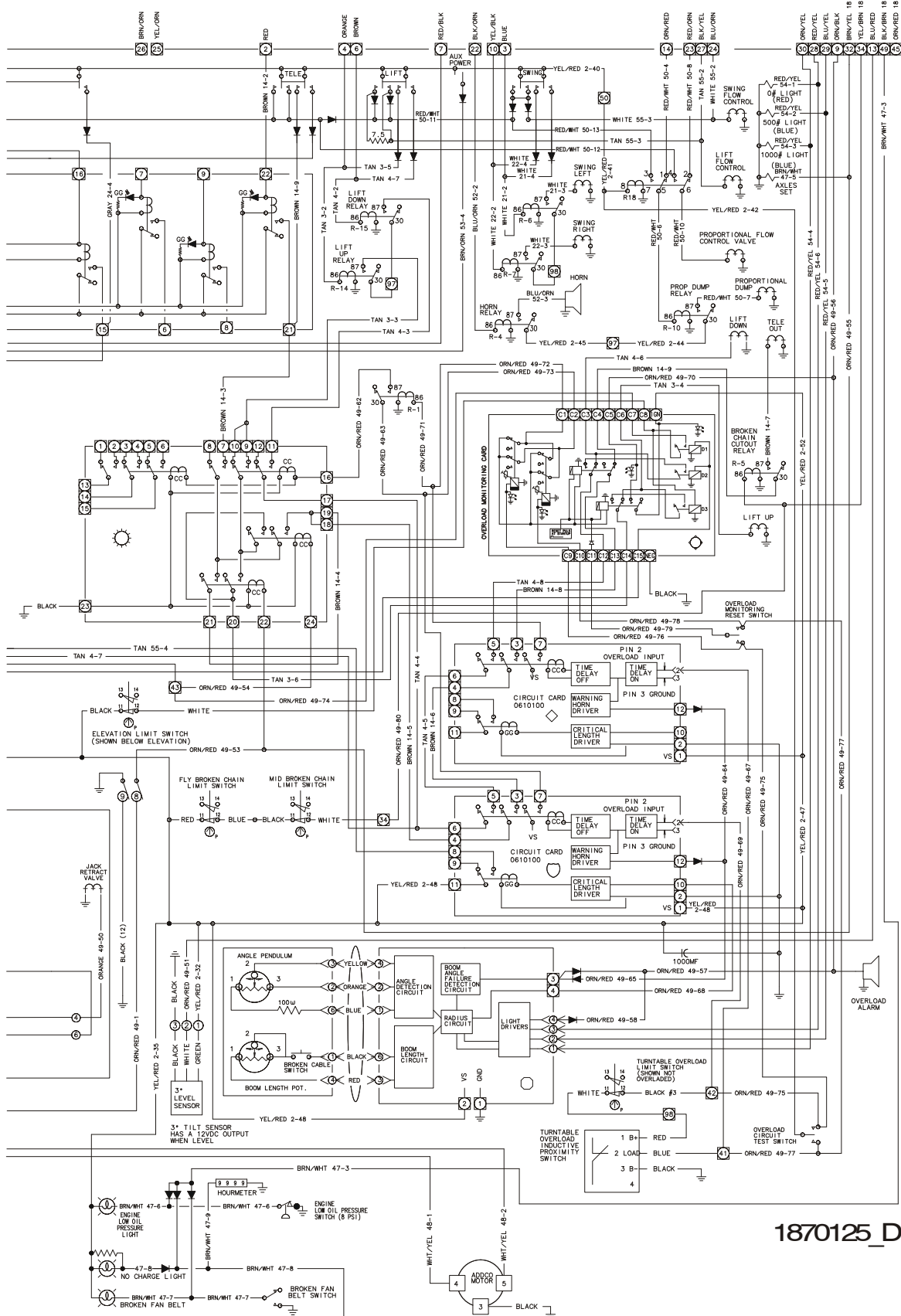

SECTION 7 ELECTRICAL

1870125\_D

# SECTION 7 ELECTRICAL

FIGURE 7-3. ELECTRICAL SCHEMATIC - 110SXJ

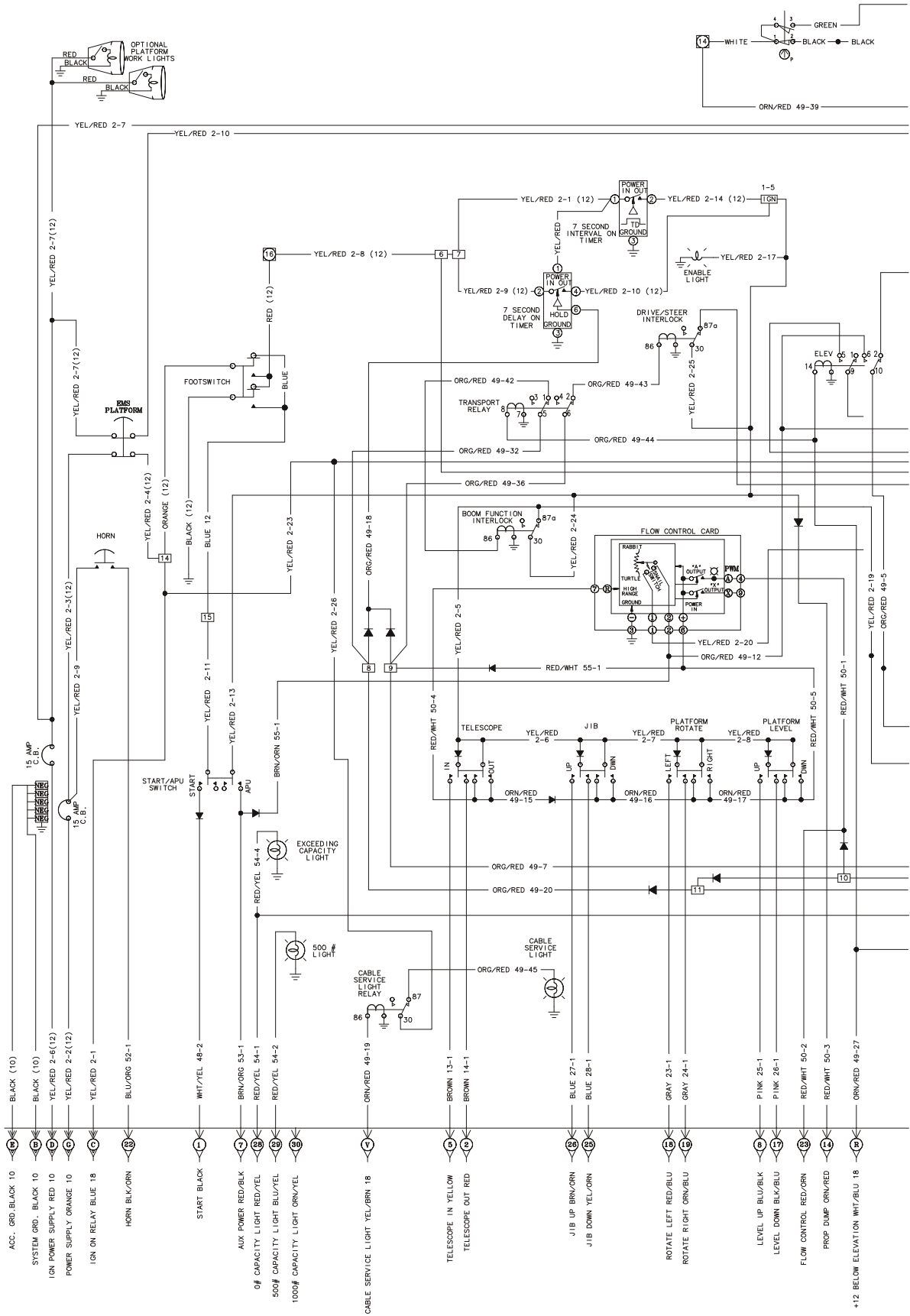

SECTION 7 ELECTRICAL

SECTION 7 ELECTRICAL

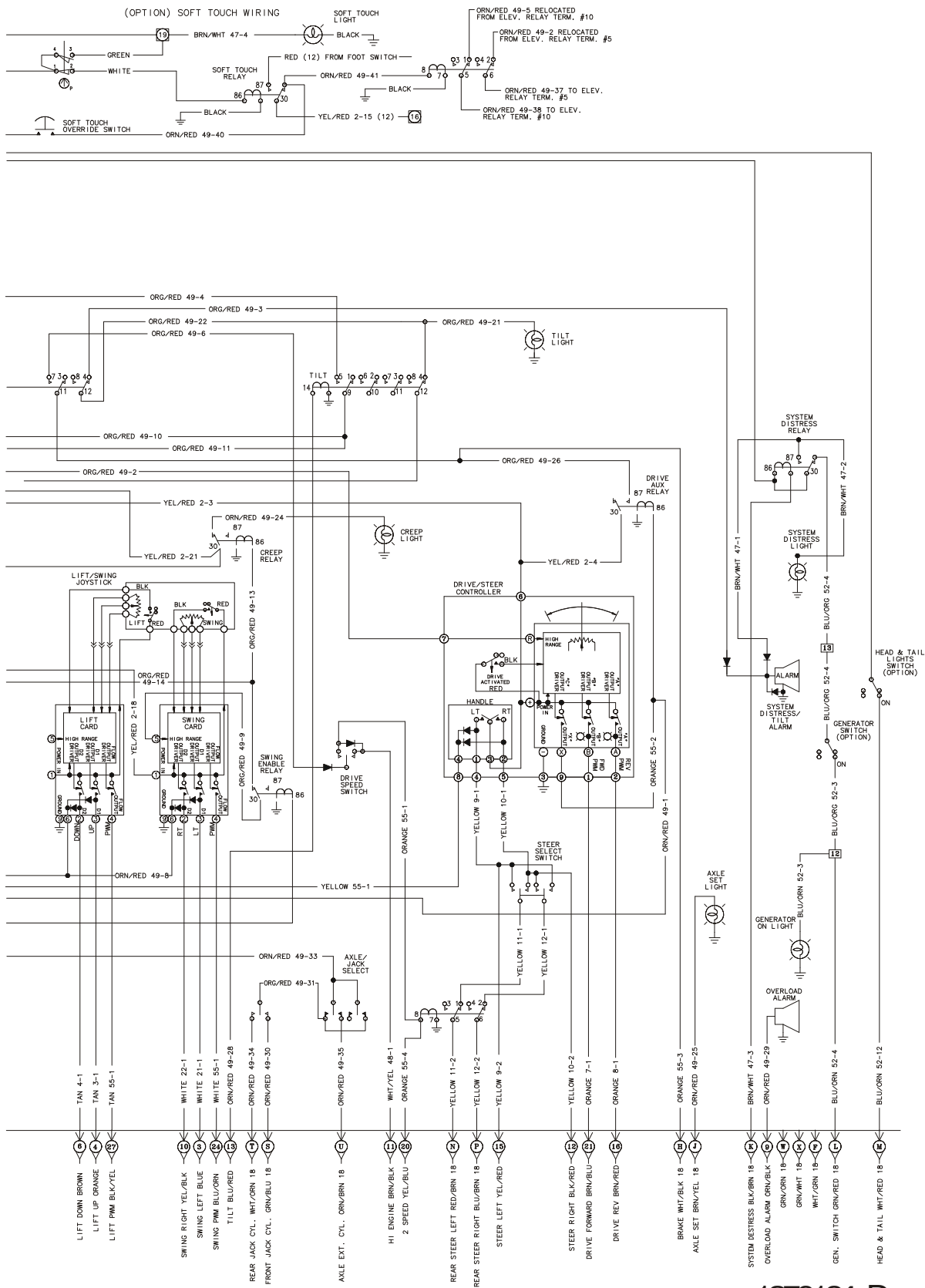

1870124\_D

SECTION 7 ELECTRICAL

# SECTION 7 ELECTRICAL

Figure 7-3. ELECTRICAL SCHEMATIC - 110SXJ

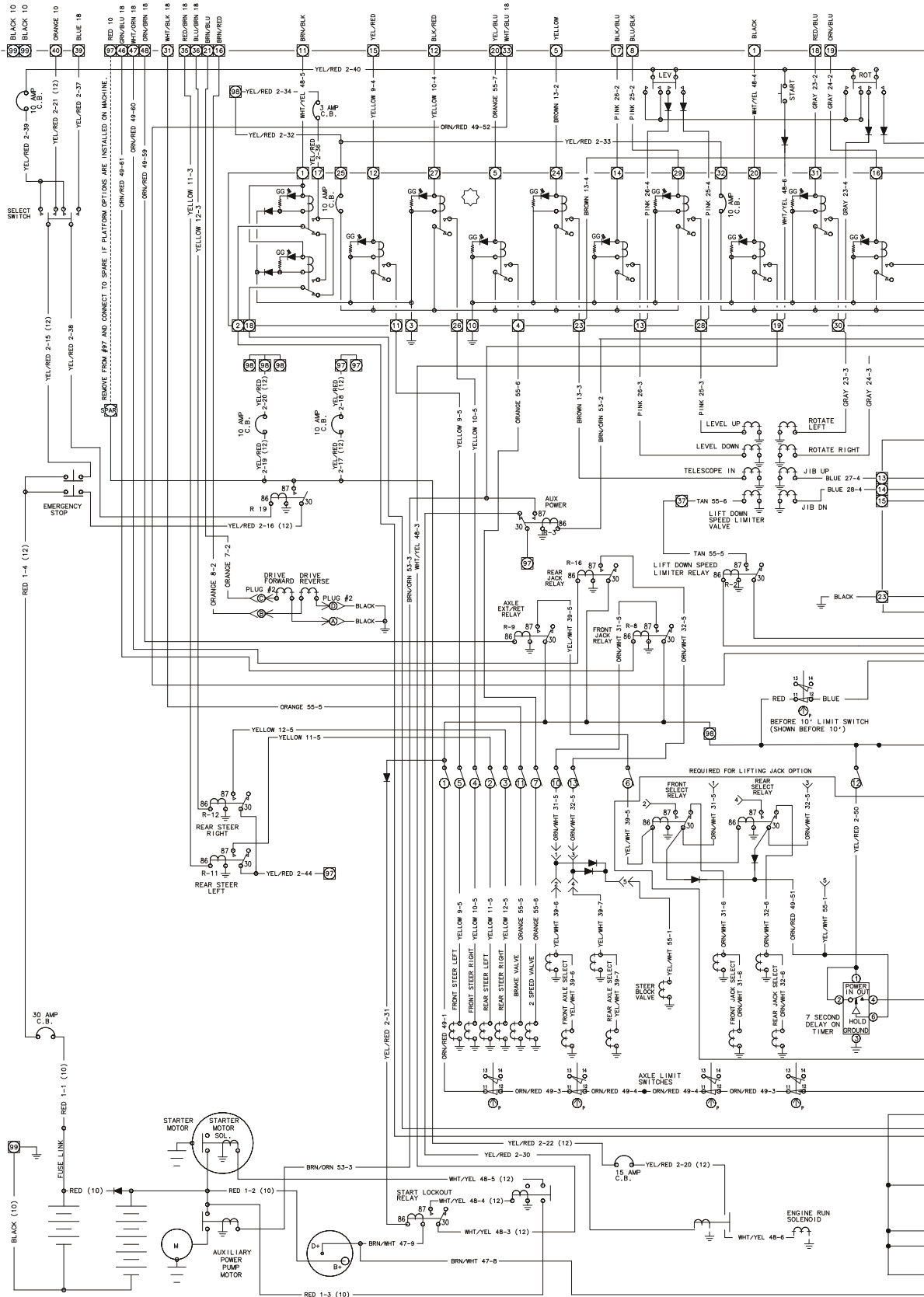

SECTION 7 ELECTRICAL

# SECTION 7 ELECTRICAL

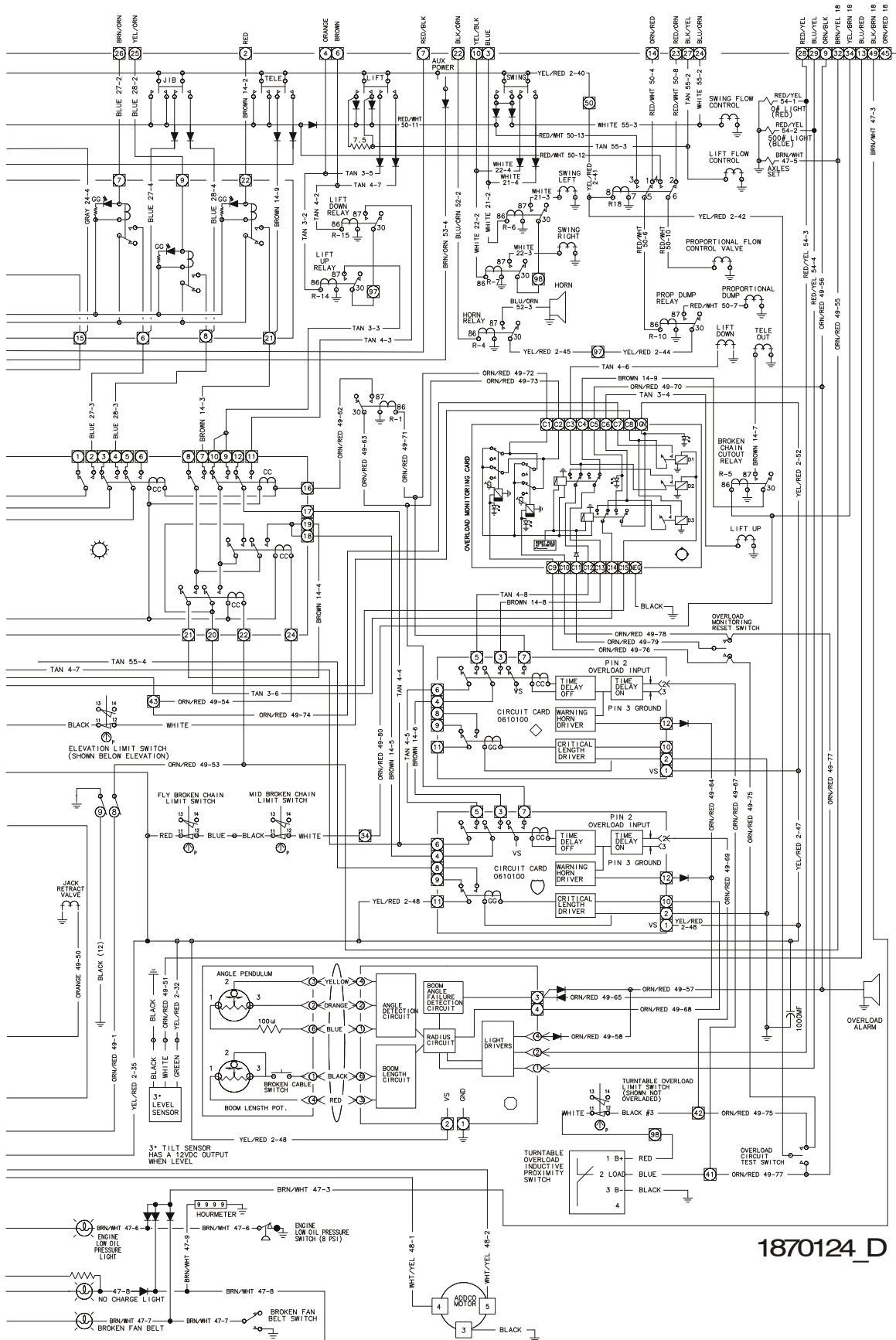

SECTION 7 ELECTRICAL

1870124\_D

# SECTION 7 ELECTRICAL

FIGURE 7-4. ELECTRICAL SCHEMATIC - 120SXJ

SECTION 7 ELECTRICAL

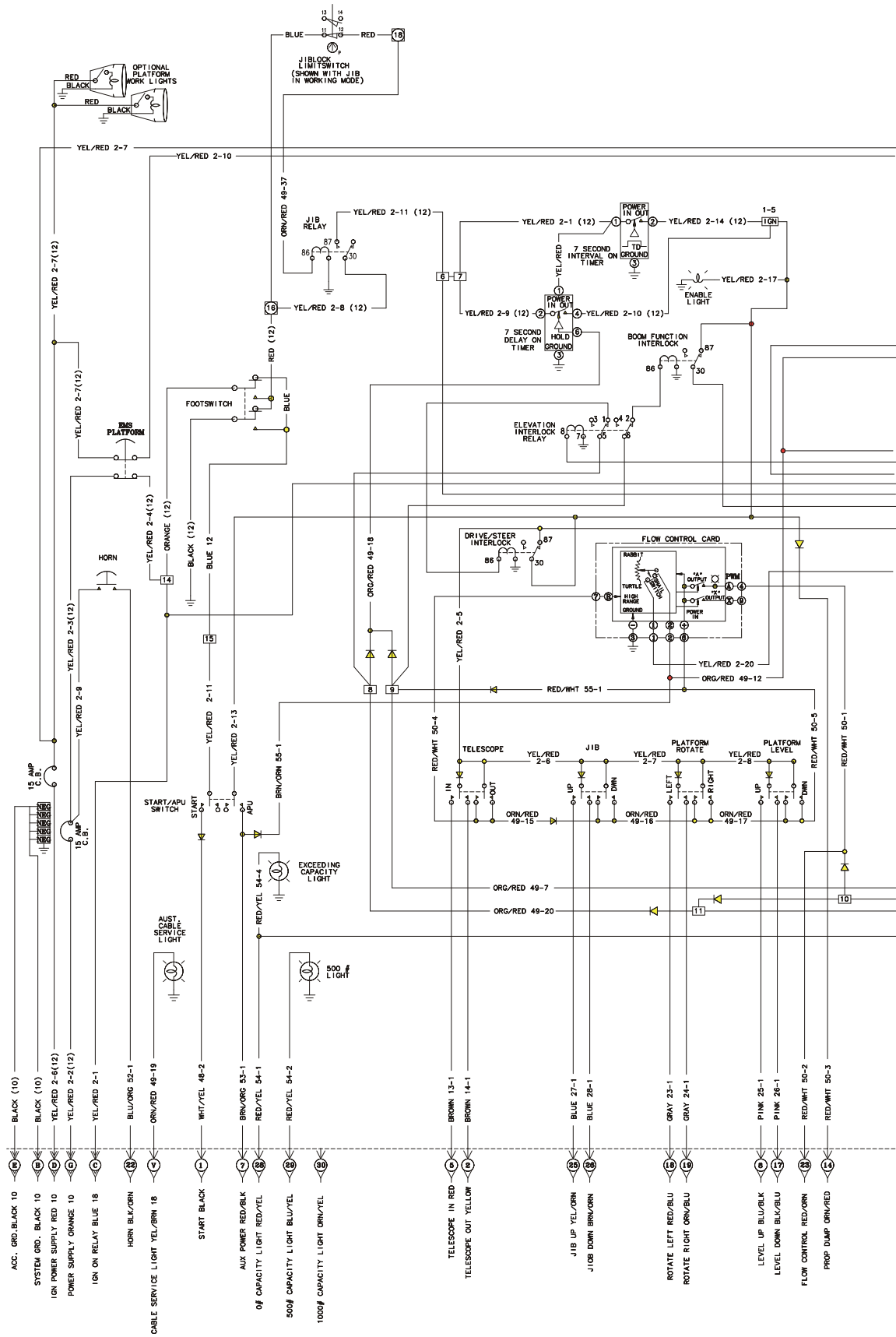

# SECTION 7 ELECTRICAL

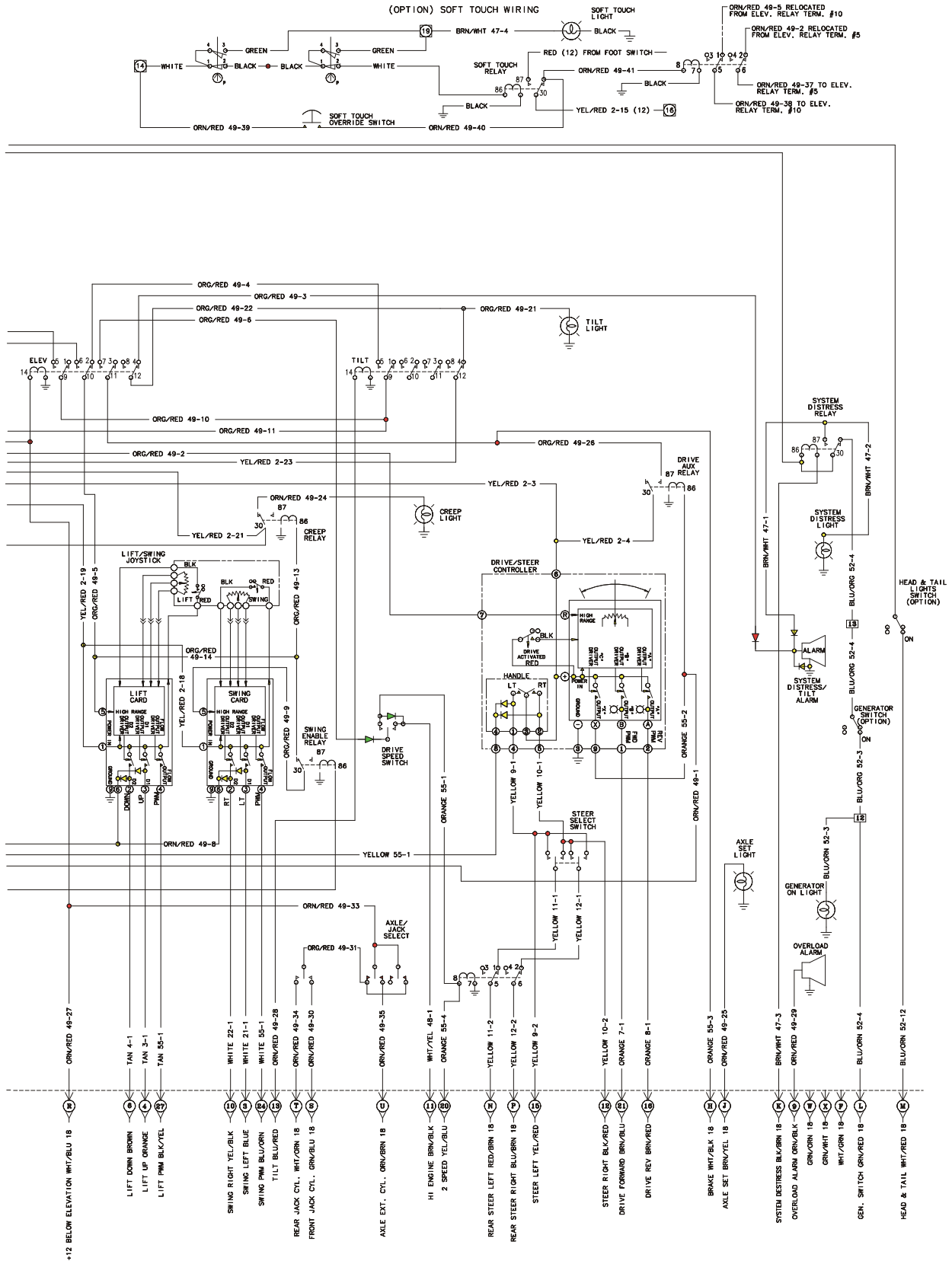

SECTION 7 ELECTRICAL

# SECTION 7 ELECTRICAL

Figure 7-4. ELECTRICAL SCHEMATIC - 120SXJ

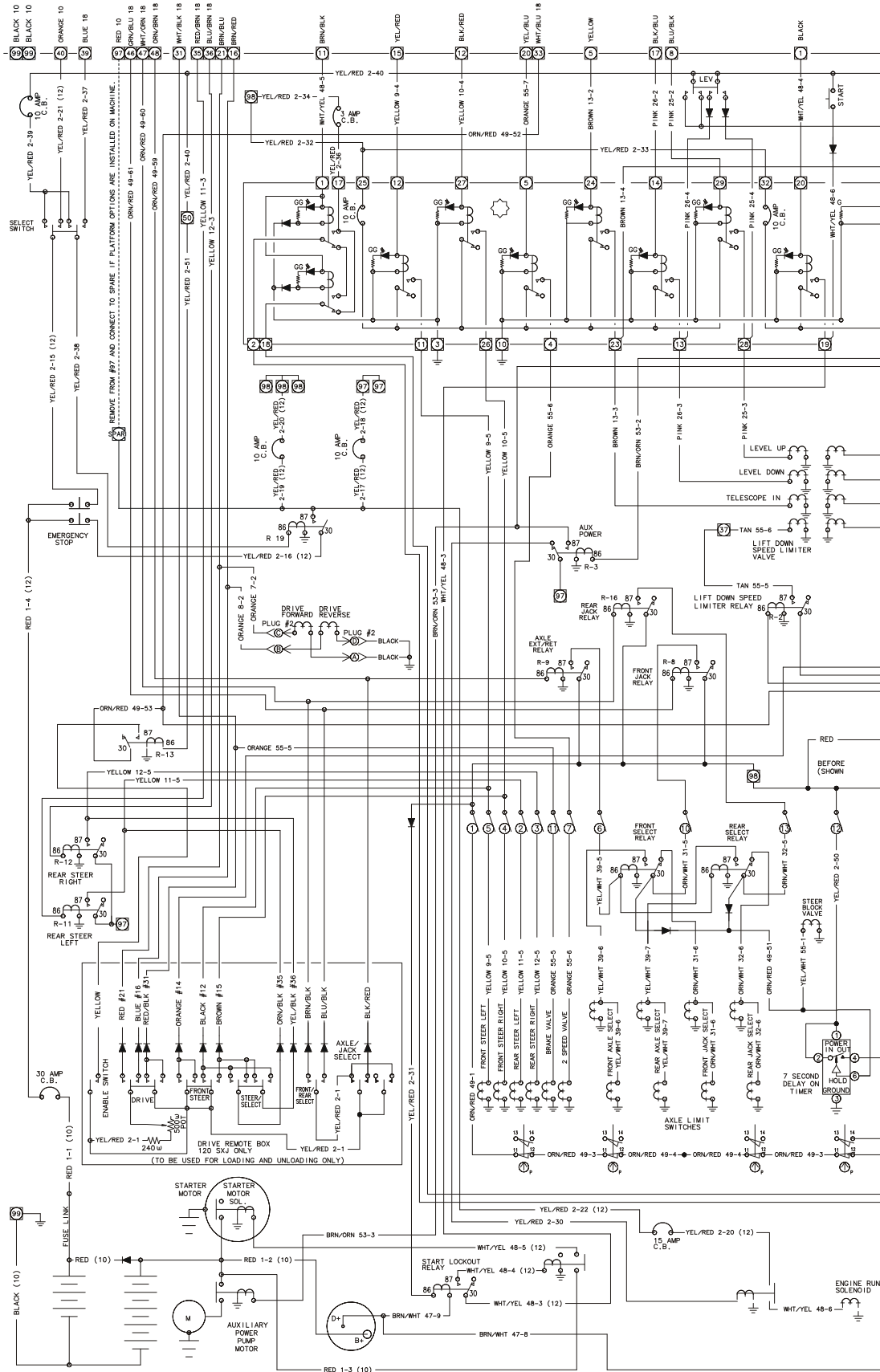

SECTION 7 ELECTRICAL



# SECTION 7 ELECTRICAL

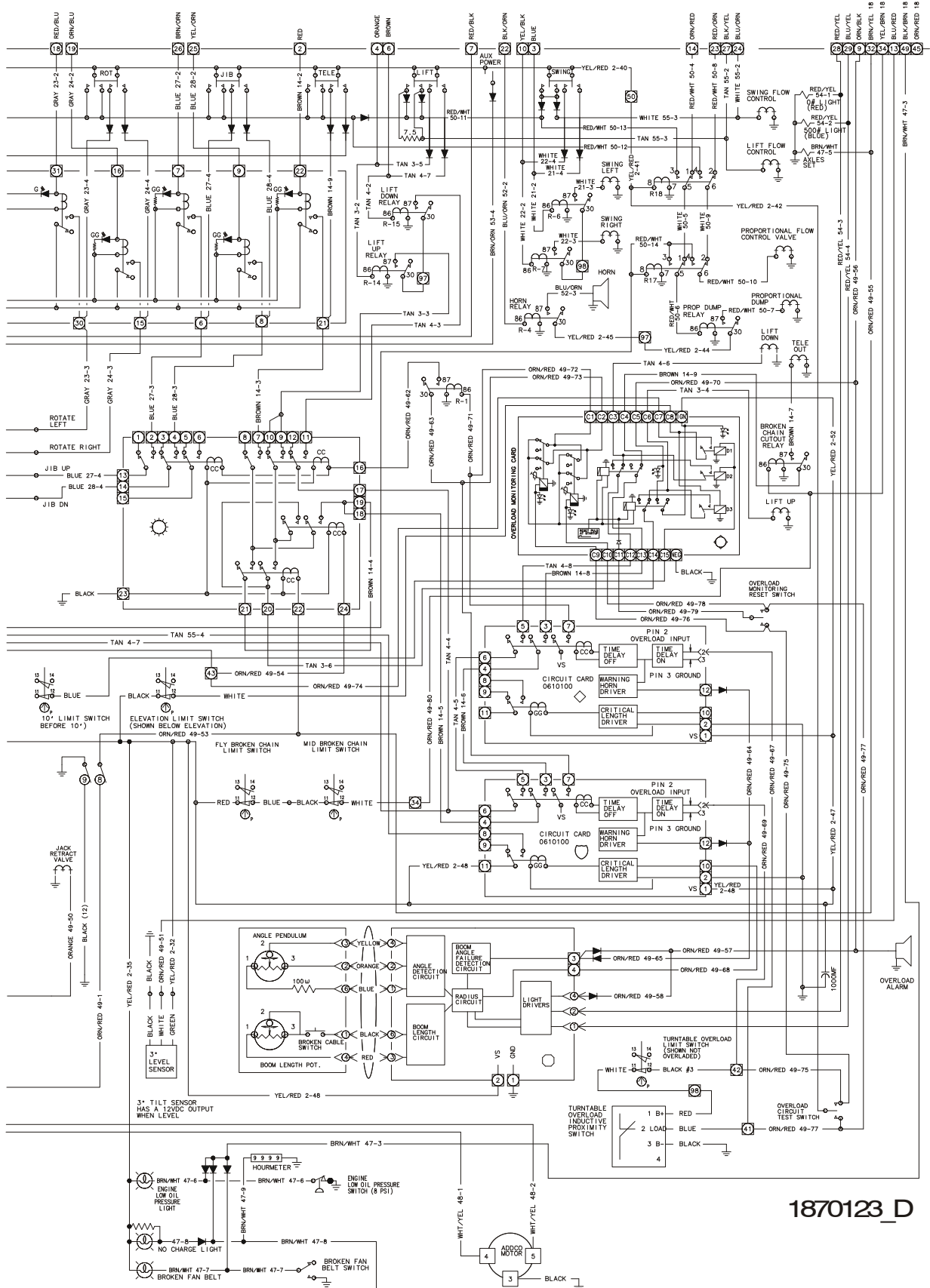

SECTION 7 ELECTRICAL

1870123\_D

# SECTION 7 ELECTRICAL

## FIGURE 7-5. HARNESS COMPONENTS INSTALLATION

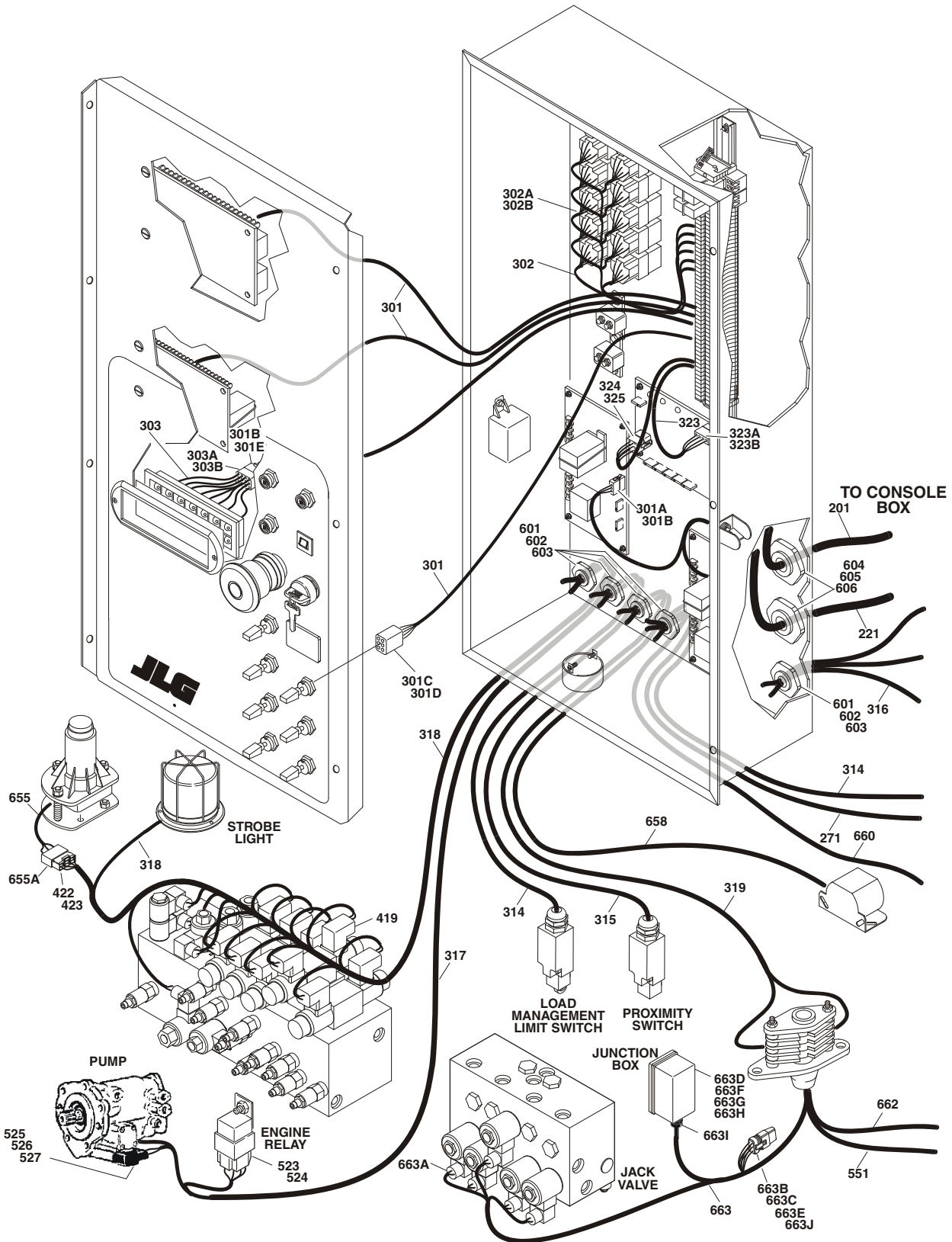

SECTION 7 ELECTRICAL

# SECTION 7 ELECTRICAL

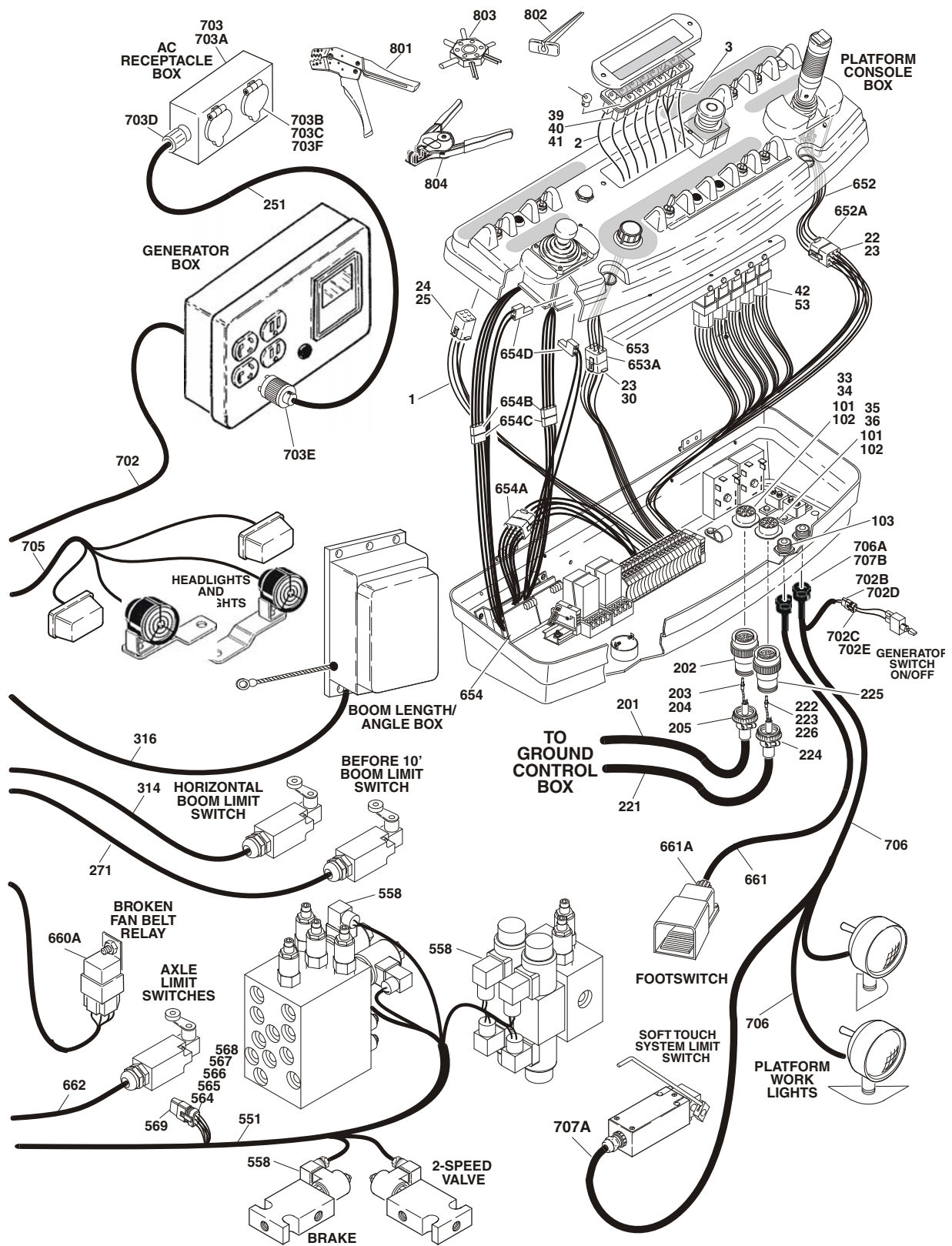

SECTION 7 ELECTRICAL

# SECTION 7 ELECTRICAL

**FIGURE 7-5. HARNESS COMPONENTS INSTALLATION**

FIG & ITEM #	PART NUMBER	DESCRIPTION	QTY.	REV.
		<b>HARNESS COMPONENTS INSTALLATION</b>	Ref.	
	4922418	<b>PLATFORM BOX HARNESS ASSEMBLY</b>	Ref.	4/B
1	Not Available	Switch Harness (Made up of Individual Wires)	A/R	
2	Not Available	Light Display Harness (Made up of Individual Wires)	A/R	
3	Not Available	Fuel Gauge Harness (Made up of Individual Wires)	A/R	
4 to 21	Not Used			
22	4460265	Connector - 9 Position	3	
23	4460268	Socket, Female	29	
24	4460418	Connector - 6 Position	7	
25	4460419	Terminal, Female	33	
26 to 29	Not Used			
30	4460266	Connector, Plug - 9 Position	1	
31 to 32	Not Used			
33	4460464	Pin, Male (16 Gauge)	41	
34	4460503	Connector - 31 Position	1	
35	4460508	Pin, Male (12 Gauge)	4	
36	4460613	Connector - 21 Position	1	
37	3990010	Diode 6 Amp (Not Shown)	18	
38	Not Used			
39	4120035	Socket, Light	A/R	
40	4460634	Insert, Terminal (Single Wire)	12	
41	4460635	Insert, Terminal (Double Wire)	8	
42	4460741	Plug - 5 Position	7	
43 to 52	Not Used			
53	4460420	Terminal	29	
54 to 55	Not Used			
		<b>PLATFORM BOX ASSEMBLY COMPONENTS</b>	Ref.	
101	4460470	Nut, Conduit	2	
102	4460471	Washer	2	
103	4460428	Connector, Strain Relief	2	
		<b>BOOM CABLE INSTALLATION - 16/30</b>		
	4922406	<b>100SXJ</b>	Ref.	2
	4922404	<b>110SX/110SXJ/110SX/110SXJ - With Inverted Track</b>	Ref.	2
	4922405	<b>120SXJ</b>	Ref.	2
201		Cable, Electrical - 16/30	A/R	
	1060516	100SX	135ft/41m	
	1060516	110SX/110SXJ	138ft/42m	
	1060516	120SXJ	149ft/45m	
202	4460502	Connector, Female - 31 Position	1	
203	4460465	Socket, Female	30	
204	4460466	Plug, Seal	1	

**SECTION 7 ELECTRICAL**

# SECTION 7 ELECTRICAL

**FIGURE 7-5. HARNESS COMPONENTS INSTALLATION**

FIG & ITEM #	PART NUMBER	DESCRIPTION	QTY.	REV.
205	4460473	Clamp, Cable	1	
		<b>BOOM HARNESS INSTALLATION - 10/4-18/16</b>		
	4922403	<b>100SXJ</b>	Ref.	2
	4922401	<b>110SX/110SXJ/110SX/110SXJ - With Inverted Track</b>	Ref.	2
	4922402	<b>120SXJ</b>	Ref.	2
221		Cable, Electrical - 10/4-18/16 Options:	A/R	
	1060676	100SX	135ft/41m	
	1060676	110SX/110SXJ	138ft/42m	
	1060676	120SXJ	149ft/45m	
222	4460465	Socket, Female	16	
223	4460466	Plug, Seal	1	
224	4460473	Clamp, Cable	1	
225	4460614	Connector, Female - 21 Position	1	
226	4460509	Socket, Female	4	
		<b>BOOM A/C CABLE INSTALLATION - 10/3 OPTIONS: AUSTRALIAN SPEC</b>		
251	1060545	100SX	131ft/40m	
	1060393	110SX/110SX - With Inverted Track	131ft/40m	
	1060393	110SXJ/110SXJ - With Inverted Track	128ft/39m	
	1060393	120SXJ	149ft/45m	
		<b>CE SPEC</b>		
	1060545	100SX/110SX	131ft/40m	
	1060545	110SXJ	128ft/39m	
	1060545	120SXJ	149ft/45m	
		<b>BOOM LIMIT SWITCH CABLE INSTALLATION - 16/4</b>		
271	1060079	Cable, Electrical - 16/4(110SXJ/120SXJ Only)	50ft/15m	
		<b>BROKEN CHAIN LIMIT SWITCH CABLE INSTALLATION - 16/3 (CE SPEC ONLY)</b>		
281	1060016	Cable, Electrical - 16/3	50ft/15m	
		<b>GROUND CONTROL BOX DIAGRAM</b>		
	4933142	<b>100SX/110SX</b>	Ref.	5/G
	4933141	<b>110SXJ</b>	Ref.	6/H
	4933140	<b>120SXJ</b>	Ref.	6/H
301		Harness - Ground Control Options:	1	
	4922438	Prior to S/N 58462		1/A
	4922461	S/N 58462 to Present		2/B
301A	4460326	Connector, Male - 3 Position	2	
301B	4460267	Pin, Male	9	
301C	4460418	Connector - 6 Position	7	
301D	4460419	Terminal, Female	39	
301E	4460343	Connector, Male - 12 Position	1	

**SECTION 7 ELECTRICAL**

# SECTION 7 ELECTRICAL

**FIGURE 7-5. HARNESS COMPONENTS INSTALLATION**

FIG & ITEM #	PART NUMBER	DESCRIPTION	QTY.	REV.
302	4922451	Harness - Relay	1	1/A
302A	4460741	Plug - 5 Position	16	
302B	4460420	Terminal	50	
303	4922389	Harness, Lights	1	2/B
303A	4460367	Connector 12 Position	1	
303B	4460268	Socket, Female	12	
304	1540003	Capacitor (Not Shown)	2	
305 to 313	Not Used			
314	1060341	Cable, Electrical 16/2	27ft/8.2m	
315	1060016	Cable, Electrical 16/3	15ft/5m	
316	1060302	Cable, Electrical 16/5	15ft/5m	
317	4922408	Harness, Engine	1	3/C
318	4922410	Harness, Valve	1	2/B
319	4922409	Harness, Slip Ring	1	1/A
320	Not Used			
321	3990010	Diode 6 Amp (Not Shown)	A/R	
322	Not Used			
323	4922460	Harness, Load Radius (100SX/110SX)	1	2/A
	4922458	Harness, Load Radius (110SXJ/120SXJ)	1	1/A
323A	4460321	Connector, Male - 4 Position	1	
323B		Pin, Male Options:	A/R	
	4460267	Prior to S/N 65544		
	4460268	S/N 65544 to Present		
324	4460225	Connector, Male - 6 Position	1	
325	4460226	Socket, Female	5	
326	2920129	Lamp, Light Display (110SX/120SXJ) (Not Shown)	7	
	4922410	<b>VALVE HARNESS ASSEMBLY</b>	Ref.	2/B
401 to 418	Not Used			
419	4460499	DIN Connector with Diode	17	
420 to 421	Not Used			
422	4460445	Connector, Female - 3 Position	1	
423	4460267	Pin, Male	3	
	4922408	<b>ENGINE HARNESS ASSEMBLY - DEUTZ ENGINE</b>	Ref.	3/C
501 to 522	Not Used			
523	4460374	Plug, Sealed	1	
524	4460375	Terminal	4	
525	4460460	Connector - 4 Position	1	
526	4460457	Terminal, Female	4	
527	4460458	Seal, Terminal	4	
528 to 529	Not Used			
	4922399	<b>STEER HARNESS ASSEMBLY</b>	Ref.	3/D
551	4922399	Harness, Steer	1	
552 to 557	Not Used			

# SECTION 7 ELECTRICAL

**FIGURE 7-5. HARNESS COMPONENTS INSTALLATION**

FIG & ITEM #	PART NUMBER	DESCRIPTION	QTY.	REV.
558	4460499	Connector, DIN with Diode	11	
559 to 563	Not Used			
564	4460225	Connector - 6 Position	1	
565	4460807	Seal, Terminal	1	
566	4460809	Sealing, Pin	1	
567	4460267	Pin, Male	5	
568	4460808	Seal, Terminal	1	
569	4922448	Harness, Plug	1	
	4460224	Connector 6 Position	1	
	4460807	Seal, Terminal	1	
	3990010	Diode 6 Amp	2	
	4460268	Socket, Female	5	
	4460809	Sealing, Pin	1	
		<b>PLATFORM BOX ASSEMBLY COMPONENTS</b>	Ref.	
601	3300048	Nut, Conduit	5	
602	0960238	Bushing, Reducer	A/R	
603	4460051	Connector, Strain Relief	A/R	
604	4460386	Connector, Strain Relief	2	
605	3300147	Nut, Conduit	2	
606	0960905	Bushing, Reducer	2	
		<b>STANDARD HARNESS COMPONENTS</b>	Ref.	
651	Not Available	Controller Harness Assembly (Lift and Swing)	1	
651A	4460266	Connector, Female - 9 Position	1	
	4460268	Socket, Female	7	
652	7019124	Controller Harness/Circuit Board Assembly (Drive and Steer)	1	
652A	4460266	Connector, Female - 9 Position	1	
	4460268	Socket, Female	7	
653	Not Available	Controller Harness - Speed	1	
653A	4460224	Connector - 6 Position	1	
	4460268	Socket, Female	6	
654	Not Available	Controller Harness Assembly (Lift and Swing)	1	
654A	4460266	Connector, Female - 9 Position	1	
	4460267	Pin, Male	9	
654B	Not Available	Connector, Male - 4 Position	2	
	Not Available	Pin, Male	4	
654C	Not Available	Connector, Female - 4 Position	2	
	Not Available	Socket, Female	8	
654C	Not Available	Connector, Female - 3 Position	2	
	Not Available	Socket, Female	3	
655	Not Available	Tilt Indicator Harness	1	
655A	4460326	Connector, Female - 3 Position	1	
	4460268	Socket, Female	3	
656	4460326	Connector, Female - 3 Position	1	
657	4460268	Socket, Female	3	

**SECTION 7 ELECTRICAL**

# SECTION 7 ELECTRICAL

**FIGURE 7-5. HARNESS COMPONENTS INSTALLATION**

FIG & ITEM #	PART NUMBER	DESCRIPTION	QTY.	REV.
658	Not Available	Alarm Harness (Travel, Descend & Motion)	A/R	
	1060341	Cable, Electrical - 16/2	11ft/3.4m	
659	3990010	Diode 6 Amp (Not Shown)	2	
660	4921886	Broken Fan Belt Harness	1	
660A	3740080	Relay	1	
	4460374	Plug, Relay	1	
	4460375	Terminal	4	
661	4922352	Footswitch Harness	1	
661A	4460071	Connector, Strain Relief	1	
662	4922400	Axle Limit Switch Harness	2	
663	4922398	Jack Harness	1	
663A	4460267	Pin, Male	2	
663B	4460499	Connector, DIN with Diode	8	
663C	4460320	Connector, Female - 2 Position	1	
663D	3990010	Diode 6 Amp (Not Shown)	5	
663E	3740113	Relay, Time Delay (Not Shown - Located inside junction box)	1	
663F	0861358	Box, Junction	1	
663G	4460428	Connector, Strain Relief	1	
		<b>OPTIONAL HARNESS COMPONENTS</b>	Ref.	
701	Not Used			
702	4922423	Generator Electrical Components	Ref.	1/A
702A	4921938	Harness On/Off	1	
702B	4460424	Terminal Housing, Female	1	
702C	4460320	Terminal Housing, Male	1	
702D	4460268	Socket, Female	2	
702E	4460267	Pin, Male	2	
703	0270275	AC to Platform Receptacle Components (110V)	Ref.	1
703A	0860038	Box, Switch	1	
703B	4460346	Receptacle	1	
703C	4060700	Shield, Cover	1	
703D	4460071	Connector, Strain Relief	1	
703E	4460205	Plug, Male	1	
703F	3960422	Gasket	1	
704	Not Available	Strobe Light Harness (Includes Strobe Light)	1	
705	Not Available	Light Harness	1	
	3740049	Relay (Not Shown)	1	
	1060341	Cable, Electrical - 16/2	45ft/13.7m	
706	2920140	Platform Worklights Harness (Includes Light and Wire Only)	2	
	2820035	Loom, Vinyl	9ft/2.8m	
706A	4460598	Connector, Strain Relief	1	
	4460042	Terminal (Not Shown-Located in Platform Console)	2	
707	Not Available	Soft-Touch System Harness	1	
707A	1600330	Cable, Electrical - 16/3	16ft/4.9m	
707B	4460425	Connector, Strain Relief	1	
708	4922502	Length Limiter	1	



# SECTION 7 ELECTRICAL

**FIGURE 7-5. HARNESS COMPONENTS INSTALLATION**

FIG & ITEM #	PART NUMBER	DESCRIPTION	QTY.	REV.
708A	4460741	Plug - 5 Position	1	
708B	4460420	Terminal	3	
708C	1060016	Cable, Electrical - 16/3	52ft/15.8m	
		<b>TOOLS</b>	Ref.	
	4921850	Service Harness (For Setting Deutz Throttle Actuator)	1	
	4922021	Service Harness (For Setting Circuit Cards)	1	
801	7002821	Crimper (For Wire to Pin/Socket Connections)	1	
802	7002823	Extractor (For Removal of Pin/Socket from Connectors)	1	
803	4460467	Extractor, Pin (Blue 16-18 Gauge) (For Removal of Pin/Socket from Connectors)	1	
	4460510	Extractor, Pin (Yellow 12-14 Gauge) (For Removal of Pin/Socket from Connectors)	1	
804	7002828	Stripper, Wire	1	

**SECTION 7 ELECTRICAL**

# SECTION 7 ELECTRICAL

FIGURE 7-5. HARNESS COMPONENTS INSTALLATION

FIG & ITEM #	PART NUMBER	DESCRIPTION	QTY.	REV.

**S  
E  
C  
T  
I  
O  
N  
  
7  
  
E  
L  
E  
C  
T  
R  
I  
C  
A  
L**

# SECTION 8 DECALS

TABLE OF CONTENTS		
FIGURE	DESCRIPTION	PAGE
8-1	DECALS INSTALLATION .....	8-2

**S  
E  
C  
T  
I  
O  
N  
  
8  
  
D  
E  
C  
A  
L  
S**

# SECTION 8 DECALS

## FIGURE 8-1.DECALS INSTALLATION

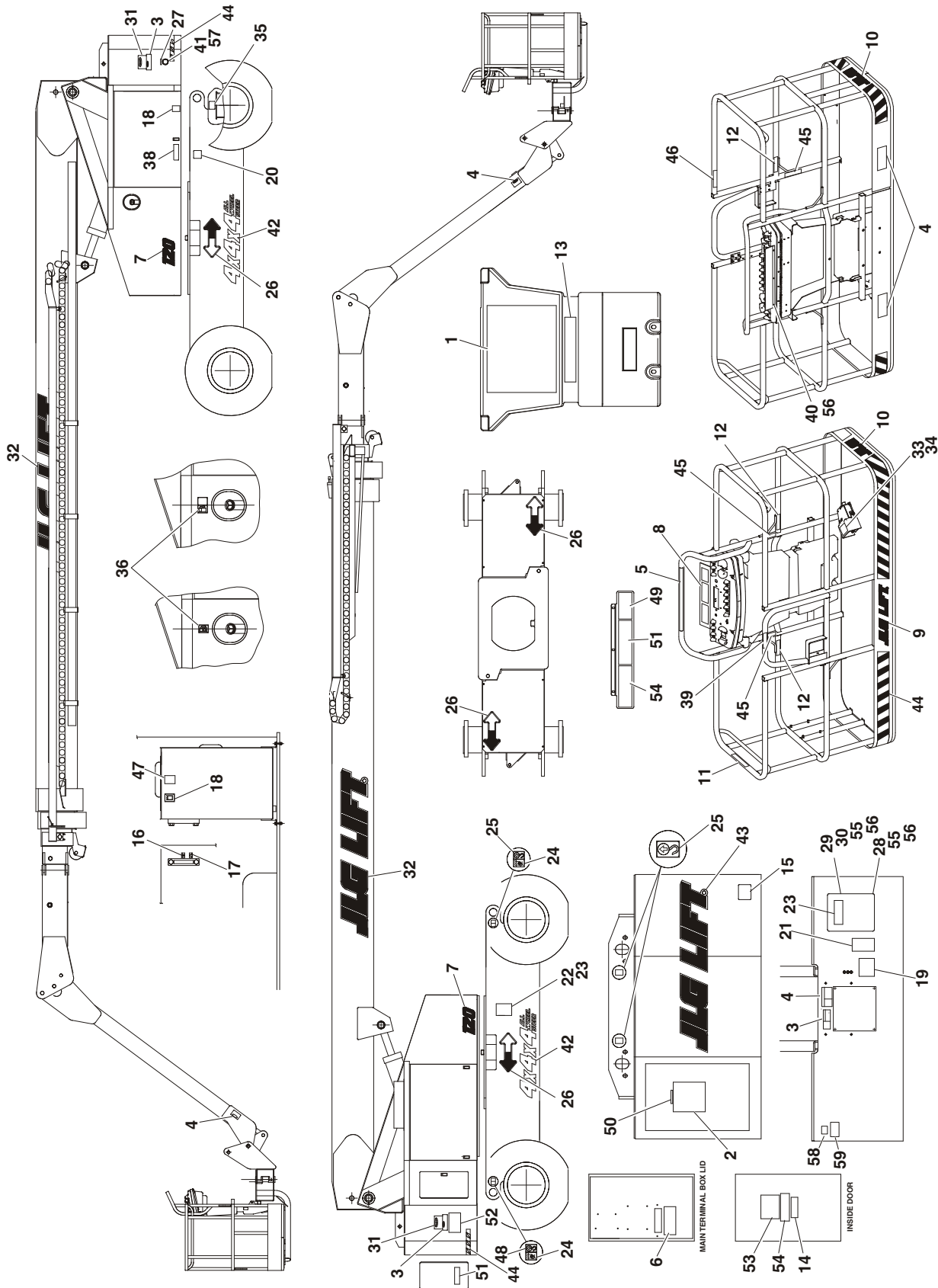

S I G N A L E D 8 8 N O - H O M E S

# SECTION 8      DECALS

**FIGURE 8-1. DECALS INSTALLATION**

FIG & ITEM #	PART NUMBER	DESCRIPTION	QTY.	REV.
		<b>STANDARD DECAL INSTALLATIONS</b>		
	0259933	<b>DECAL - JLG</b>	Ref.	1
	0270249	<b>MODEL 100SX/110SX - AUSTRALIAN SPEC</b>	Ref.	5
	0270307	<b>MODELS 110SXJ/120SXJ - AUSTRALIAN SPEC</b>	Ref.	5
	0270245	<b>MODEL 100SX/110SX - DUTCH SPEC</b>	Ref.	6
	0270304	<b>MODELS 110SXJ/120SXJ - DUTCH SPEC</b>	Ref.	5
	0270242	<b>MODEL 100SX/110SX - FRENCH SPEC</b>	Ref.	6
	0270301	<b>MODELS 110SXJ/120SXJ - FRENCH SPEC</b>	Ref.	5
	0270243	<b>MODEL 100SX/110SX - GERMAN SPEC</b>	Ref.	6
	0270302	<b>MODELS 110SXJ/120SXJ - GERMAN SPEC</b>	Ref.	5
	0270244	<b>MODEL 100SX/110SX - ITALIAN SPEC</b>	Ref.	6
	0270303	<b>MODELS 110SXJ/120SXJ - ITALIAN SPEC</b>	Ref.	5
	0270246	<b>MODEL 100SX/110SX - SPANISH SPEC</b>	Ref.	6
	0270305	<b>MODELS 110SXJ/120SXJ - SPANISH SPEC</b>	Ref.	5
	0270241	<b>MODEL 100SX/110SX - U.K. SPEC</b>	Ref.	7
	0270165	<b>MODELS 110SXJ/120SXJ - U.K. SPEC</b>	Ref.	6
1		Decal - Danger/Warning (Platform) Options:	1	
	1703992	Australian Spec		
	1703913	Dutch Spec		
	1703917	French Spec		
	1703799	German Spec		
	1703915	Italian Spec		
	1703919	Spanish Spec		
	1703806	U.K. Spec		
2		Decal - Danger/Warning (Ground Control) Options:	1	
	1703807	Australian Spec		
	1703914	Dutch Spec		
	1703918	French Spec		
	1703800	German Spec		
	1703916	Italian Spec		
	1703920	Spanish Spec		
	1703807	U.K. Spec		
3	Not Used			
4	1701518	Decal - Warning Crushing	5	
5	Not Used			
6	Not Used			
7		Decal - Model Designation Options:	2	
	1704599	Model 100SX		
	1704591	Model 110SX		
	1704590	Model 110SXJ		
	1704592	Model 120SXJ		
8	3572327	Plate, Decal Mount	1	
9	1702774	Decal - JLG Lift (3.5in)	1	
10	1702773	Decal - JLG (5in)	2	
11	1702868	Decal - No Hands	2	

**SECTION 8 DECALS**

# SECTION 8      DECALS

**FIGURE 8-1. DECALS INSTALLATION (CONTINUED)**

FIG & ITEM #	PART NUMBER	DESCRIPTION	QTY.	REV.
12		Decal - Attach Lanyard Here Options:	4	
	1704277	Australian Spec		
	1704277	Dutch/French/German/Italian/Spanish/U.K. Spec		
13		Decal - Capacity (Platform) Options:	1	
	1701645	Australian Spec		
	Not Required	Dutch/French/German/Italian/Spanish/U.K. Spec		
14		Decal - Capacity (Ground Control) Options:	1	
	1702688	Australian Spec		
	Not Required	Dutch/French/German/Italian/Spanish/U.K. Spec		
15		Decal - Sound Power Level Options:	1	
	Not Required	Australian Spec		
		Dutch/French/German/Italian/Spanish/U.K. Spec		
	1702928	Prior to S/N 65572		
	1705084	S/N 65572 to Present		
16	1701502	Decal - High Oil Level	1	
17	1701503	Decal - Low Oil Level	1	
18	1701504	Decal - Hydraulic Oil	2	
19	Not Used			
20	Not Available	Decal - Bar Code	1	
21	1700584	Decal - Patent	1	
22	Not Available	Nameplate - Serial Number	1	
23	1701509	Decal - Manual	1	
24	1702300	Decal - Tie Down	6	
25	1701500	Decal - Lift	4	
26	1701501	Decal - Arrow	4	
27		Nameplate - 240V-50Hz Options:	1	
	3251242	Australian Spec		
	Not Required	Dutch/French/German/Italian/Spanish/U.K. Spec		
28	0860520	Box, Manual Storage	1	
29	1060279	Cable, Lanyard	1	
30	0641408	Bolt 1/4"-20NC x 1"	1	
31	1701518	Decal - Warning Crushing	2	
32	1702862	Decal - JLG Lift (12in)	2	
33	3820001	Rivet	8	
34		Decal - Footswitch Options:	1	
	Not Required	Australian Spec		
	1703518	Dutch Spec		
	1693292	French Spec		
	1693294	German Spec		
	1701600	Italian Spec		
	1701791	Spanish Spec		
	Not Required	U.K. Spec		
35	1703481	Decal - Maximum Tire Load	4	
36	1701505	Decal - Fuel (See Engine Installation)	1	
37	Not Required			
38	Not Required			
39	Not Required			
40	0641406	Bolt 1/4"-20NC x 3/4"	3	

# SECTION 8      DECALS

**FIGURE 8-1. DECALS INSTALLATION (CONTINUED)**

FIG & ITEM #	PART NUMBER	DESCRIPTION	QTY.	REV.
41	Not Used			
42		Decal Options:	2	
	1704600	Decal - 4 x 4		
	1704581	Decal - 4 x 4 x 4 All Wheel Steer		
43	1702861	Decal - JLG Lift (8in)	1	
44	4420051	Decal - Warning Stripes	18ft/5.49m	
45	Not Used			
46	Not Used			
47	1704412	Decal - Hydraulic Oil Chart	1	
48	1701499	Decal - No Lift	2	
49		Decal - Warning Tip-Over Options:	1	
	1704606	Australian Spec		
	1704642	Dutch Spec		
	1704639	French Spec		
	1704640	German Spec		
	1704641	Italian Spec		
	1704643	Spanish Spec		
	1704606	U.K. Spec		
50		Decal - GC Location Options:	1	
	1701840	Australian Spec		
	1701616	Dutch Spec		
	1701515	French Spec		
	1693285	German Spec		
	1701599	Italian Spec		
	1701789	Spanish Spec		
	1701840	U.K. Spec		
51		Decal Options:	1	
	1704544	Decal - Axle Instructions (Prior to S/N 54101)		
		Decal - Warning Options: (S/N 54101 to Present)		
	1704755	Australian Spec/U.K. Spec		
	1704760	Dutch Spec		
	1704757	French Spec		
	1704758	German Spec		
	1704759	Italian Spec		
	1704761	Spanish Spec		
52		Decal - Lift Diagram Options:	1	
	Use 1705397	100SX/110SX - Australian Spec (Was P/N 3252696) (Prior to S/N 67976)		
	Use 1705396	110SXJ - Australian Spec (Was P/N 3252697) (Prior to S/N 67976)		
	Use 1705395	120SXJ - Australian Spec (Was P/N 3252698) (Prior to S/N 67976)		
	Use 1705397	100SX/110SX - Dutch Spec (Was P/N 3252704) (Prior to S/N 67976)		
	Use 1705396	110SXJ - Dutch Spec (Was P/N 3252715) (Prior to S/N 67976)		
	Use 1705395	120SXJ - Dutch Spec (Was P/N 3252726) (Prior to S/N 67976)		

# SECTION 8      DECALS

**FIGURE 8-1. DECALS INSTALLATION (CONTINUED)**

FIG & ITEM #	PART NUMBER	DESCRIPTION	QTY.	REV.
52 (cont'd)	Use 1705397	100SX/110SX - French Spec (Was P/N 3252701) (Prior to S/N 67976)		
	Use 1705396	110SXJ - French Spec (Was P/N 3252712) (Prior to S/N 67976)		
	Use 1705395	120SXJ - French Spec (Was P/N 3252723) (Prior to S/N 67976)		
	Use 1705397	100SX/110SX - German Spec (Was P/N 3252702)(Prior to S/N 67976)		
	Use 1705396	110SXJ - German Spec (Was P/N 3252713) (Prior to S/N 67976)		
	Use 1705395	120SXJ - German Spec (Was P/N 3252724) (Prior to S/N 67976)		
	Use 1705397	100SX/110SX - Italian Spec (Was P/N 3252703) (Prior to S/N 67976)		
	Use 1705396	110SXJ - Italian Spec (Was P/N 3252714) (Prior to S/N 67976)		
	Use 1705395	120SXJ - Italian Spec (Was P/N 3252725) (Prior to S/N 67976)		
	Use 1705397	100SX/110SX - Spanish Spec (Was P/N 3252705) (Prior to S/N 67976)		
	Use 1705396	110SXJ - Spanish Spec (Was P/N 3252716) (Prior to S/N 67976)		
	Use 1705395	120SXJ - Spanish Spec (Was P/N 3252727) (Prior to S/N 67976)		
	Use 1705397	100SX/110SX - U.K. Spec (Was P/N 3252696) (Prior to S/N 67976)		
	Use 1705396	110SXJ - U.K. Spec (Was P/N 3252697) (Prior to S/N 67976)		
	Use 1705395	120SXJ - U.K. Spec (Was P/N 3252698) (Prior to S/N 67976)		
53		Decal - Load Management Options:	1	
	1704583	Australian Spec (Prior to S/N 56951)		
	1704899	Australian Spec (S/N 56951 to Present)		
	1704654	Dutch Spec		
	1704651	French Spec		
	1704652	German Spec		
	1704653	Italian Spec		
	1704655	Spanish Spec		
	1704583	U.K. Spec (Prior to S/N 56951)		
	1704899	U.K. Spec (S/N 56951 to Present)		
	54			
1704541		Australian Spec		
1704631		Dutch Spec		
1704628		French Spec		
1704629		German Spec		
1704630		Italian Spec		
1704632		Spanish Spec		
1704541		U.K. Spec		
55	3311405	Locknut 1/4"-20NC	6	
56	4751400	Flatwasher 1/4"	9	

**SECTION 8 DECALS**



# SECTION 8      DECALS

**FIGURE 8-1. DECALS INSTALLATION (CONTINUED)**

FIG & ITEM #	PART NUMBER	DESCRIPTION	QTY.	REV.
57	0961127	Bushing, Snap	1	
58	1701543	Decal, LPG (Not Shown)	2	
59	1700818	Decal, Liquid Withdrawal System (Not Shown)	2	
	0100010	----- Loctite #242	A/R	

**SECTION 8 DECALS**

# SECTION 8 DECALS

FIGURE 8-1. DECALS INSTALLATION (CONTINUED)

FIG & ITEM #	PART NUMBER	DESCRIPTION	QTY.	REV.

**S  
E  
C  
T  
I  
O  
N  
  
8  
  
D  
E  
C  
A  
L  
S**

# SECTION 9 RECOMMENDED SERVICE PARTS STOCK

## MODELS 100SX/110SX/110SXJ/120SXJ

The following list will service fleets of machines (built to current production per date on the front cover) with emergency repair parts which can be installed in the field. Parts from the list should be replaced when inventory is depleted to keep service parts stock supplied. For further information, contact your JLG dealer or the JLG Industries Parts Department.

JLG PART NUMBER	DESCRIPTION	QTY PER FLEET		
		1-10	10-20	20 OR MORE
<b>STANDARD PARTS</b>				
7012944	Coil (Figures 1-1 & 2-3)	1	1	1
7021401	Coil (Figures 1-1 & 2-3)	1	1	1
7012943	Coil (Figures 1-2, 1-8 & 2-3)	1	1	1
4360363	Switch, Level Sensor (Figure 2-2)	1	1	1
7017451	Coil (Figure 2-3)	1	1	1
0610084	Board, Circuit - Engine Relay (Figure 2-10)	1	1	1
0610080	Board, Circuit - Select (Figure 2-10)	1	1	1
0610130	Board, Circuit - Load Radius (Figure 2-10)	1	1	1
0610100	Board, Circuit - Overload (Figure 2-10)	1	1	1
3740070	Relay - SPDT (Figure 2-10)	1	1	1
3740016	Relay - 3PDT (Figures 2-10 & 4-5)	1	1	1
3740122	Relay - 2PDT (Figure 2-10)	1	1	1
3740049	Relay - 5PDT (Figures 2-10 & 4-5)	1	1	1
4360216	Breaker, Circuit - 30 Amp (Figure 2-10)	1	1	1
4360232	Breaker, Circuit - 15 Amp (Figure 2-10)	1	1	1
4360470	Switch, Key (Figure 2-10)	1	1	1
2860030	Key, Replacement (Figure 2-10)	1	1	1
4360212	Breaker, Circuit - 3 Amp (Figure 2-10)	1	1	1
4360314	Switch, Toggle (Figures 2-10, 2-11 & 4-5)	1	1	1
4360331	Switch, Toggle (Figure 2-11)	1	1	1
4360475	Switch, Mushroom (Figures 2-10, 2-11 & 4-5)	1	1	1
3740112	Relay (Figure 2-10)	1	1	1
4360476	Contact, Switch Block (Figures 2-10 & 4-5)	1	1	1
4360328	Switch, Toggle (Figures 2-10 & 4-5)	1	1	1
4360069	Breaker, Circuit - 10 Amp (Figure 2-10)	1	1	1
4360340	Switch, Potentiometer (Figure 2-11)	1	1	1
4360345	Switch, Toggle (Figures 2-11 & 4-5)	1	1	1
3990001	Diode - 3 Amp (Figure 2-11)	1	1	1
2120136	Element, Charge Pump Filter (Figure 2-12)	4	8	12
3740059	Relay (Figure 2-12)	1	1	1
3740067	Relay (Figure 2-12)	1	1	1
7008829	Board, Circuit (Figure 2-12)	1	1	1
7008828	Cable, Throttle (Figure 2-12)	1	1	1
7004214	Element, Air Filter (Figure 2-12)	1 Dozen	1 Dozen	1 Dozen
7000649	Filter, Engine Fuel (Deutz) (Figure 2-12)	1	1	1
7014503	Filter, Engine Oil (Deutz) (Figure 2-12)	1 case	1 case	1 case
1660233	Coupling (Deutz) (Figure 2-13)	1	1	1
1340046	Breather, Hydraulic (Figure 2-16)	1	1	1
2120129	Element, Hydraulic Oil Filter (Figure 2-16)	4	8	12
3740080	Relay (Figures 2-12 & 2-19)	1	1	1

# SECTION 9 RECOMMENDED SERVICE PARTS STOCK

## MODELS 100SX/110SX/110SXJ/120SXJ

The following list will service fleets of machines (built to current production per date on the front cover) with emergency repair parts which can be installed in the field. Parts from the list should be replaced when inventory is depleted to keep service parts stock supplied. For further information, contact your JLG dealer or the JLG Industries Parts Department.

JLG PART NUMBER	DESCRIPTION	QTY PER FLEET		
		1-10	10-20	20 OR MORE
4360336	Switch, Toggle (Figure 4-5)	1	1	1
3740113	Relay, Timer (Figure 4-5)	1	1	1
3740115	Relay, Timer (Figure 4-5)	1	1	1
1600306	Controller (Lift & Swing) (Figure 4-5)	1	1	1
1600287	Controller (Drive & Steer) (Figure 4-5)	1	1	1
4360387	Switch, Pushbutton (Figures 4-5 & 4-8)	1	1	1
4360331	Switch, Toggle (Figure 4-5)	1	1	1
3740123	Relay (Figure 4-5)	1	1	1
1600307	Card, Control (Figure 4-5)	1	1	1
7003961	Microswitch (Figures 4-6 & 4-7)	1	1	1
3990010	Diode - 6 Amp (Figure 7-5)	1	1	1
<b>VARIABLE PARTS</b>				
70003143	Powertrack Repair Section Without Chip Covers - Left Side (Figure 3-1)	1	1	1
7006503	Powertrack Repair Section With Chip Covers - Left Side (Figure 3-1)	1	1	1
7006153	Powertrack Repair Section Without Chip Covers - Right Side (Figure 3-1)	1	1	1
70003145	Powertrack Repair Section With Chip Covers - Right Side (Figure 3-1)	1	1	1
4360322	Switch, Limit (Figure 1-3)	1	1	1
4360301	Switch, Limit (Figure 2-1)	1	1	1
4360263	Switch, Limit (Figure 2-9)	1	1	1
4360259	Switch, Proximity (Figure 2-9)	1	1	1
4360277	Switch, Limit (Figures 3-3 & 3-5)	1	1	1
4360057	Switch, Limit (Figure 4-9)	1	1	1

# SECTION 10 SPECIAL OPTIONS

**Note: This list is to accommodate machines ordered with special equipment. Options may not be applicable to all models. For more specific parts information contact JLG Parts Department.**

FIG & ITEM #	PART NUMBER	DESCRIPTION	QTY.	REV.
10—1		<b>MISCELLANEOUS SPECIAL OPTIONS</b>	Ref.	
	0271398	<b>Airline 1/2" &amp; Weld Lead Installation</b>	Ref.	
	0271462	<b>Airline Installation, 1/2" (110SX)</b>	Ref.	
	0271463	<b>Airline Installation, 1/2" (110SXJ)</b>	Ref.	
	0271471	<b>Airline Installation, 1/2" (100SX)</b>	Ref.	
	0271202	<b>Airline Installation, 1/2" (120SXJ)</b>	Ref.	
	0270281	<b>Bellows, Cylinder (100SX/110SX)</b>	Ref.	
	0270282	<b>Bellows, Cylinder (110SXJ/120SXJ)</b>	Ref.	
	0270825	<b>Brake Lights Installation</b>	Ref.	
	0256789	<b>Camera Mounting Installation</b>	Ref.	
	0272191	<b>Console Cover, Rubber</b>	Ref.	
	1580012	<b>Container, Storage Tray (Center)</b>	Ref.	
	1580013	<b>Container, Storage Tray (Rail)</b>	Ref.	
	0254109	<b>Exhaust Purifier Installation</b>	Ref.	
	3220088	Muffler, Exhaust Purifier	1	
	4566219	Tube, Exhaust	1	
		<b>Filter Kits (Deutz Engine):</b>	Ref.	
	1001111010	<b>Combined Filter Kit (Hydraulic/Air &amp; Fuel/Engine Oil)</b>	1	
	1001109714	<b>Hydraulic/Air Filter</b>	1	
	1001110131	<b>Fuel/Engine Oil Filter</b>	1	
	0270319	<b>Head &amp; Tail Lights Installation</b>	Ref.	
	2920110	Light, Head	2	
	2920113	Light, Tail	2	
	0253649	<b>Manual Descent Installation</b>	Ref.	
	0253050	<b>Pinion Installation</b>	Ref.	
	0270723	<b>Platform Beacon Light Installation</b>	Ref.	
	0255398	<b>Platform Console Cover Installation</b>	Ref.	
	0251059	<b>Platform Step Installation</b>	Ref.	

# SECTION 10 SPECIAL OPTIONS

SECTION 10 SPECIAL OPTIONS

FIG & ITEM #	PART NUMBER	DESCRIPTION	QTY.	REV.
	0270511	<b>Rail Extension (36"x 72") (0.9m X 1.83m)</b>	Ref.	
	0271771	<b>Rail Extension (36"x 96") (0.9m X 2.44m)</b>	Ref.	
	4060959	<b>Shield, Footswitch</b>	1	
	0270320	<b>Strobe Light Installation - Amber</b>	Ref.	
	0272507	Strobe Light/Guard/Harness Assembly	1	
		Bulb, Replacement Options:		
	7016380	Bulb for ECCO Model 6640		
	70001941	Bulb for ECCO Model 6650		
		Guard Options:		
	4060907	Bulb for ECCO Model 6640		
	2920215	Bulb for ECCO Model 6650		
		<b>Tools for Service:</b>		
	7002821	<b>Crimper, Wire</b>	Ref.	
	2900838	<b>Fastener Kit - U.S. Standards</b>	Ref.	
	7002823	<b>Pin Extractor - Universal (For Electrical Connectors with Pins and Sockets)</b>	Ref.	
	7016654	<b>Screwdriver, Magnetic</b>	Ref.	
	7002822	<b>Screwdriver, Pontimeter</b>	Ref.	
	7004275	<b>Seal Tool 1" (For Cylinders)</b>	Ref.	
	7004276	<b>Seal Tool 1 1/2" (For Cylinders)</b>	Ref.	
	7002828	<b>Stripper, Wire</b>	Ref.	
	7014676	<b>Tool Kit - U.S. Standards</b>	Ref.	
	0271203	<b>Weld Lead Installation (120SXJ)</b>	Ref.	



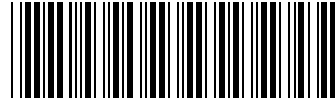

3121811



An Oshkosh Corporation Company

Corporate Office  
JLG Industries, Inc.  
1 JLG Drive  
McConnellsburg PA. 17233-9533  
USA

☎ (717) 485-5161

📠 (717) 485-6417

## JLG Worldwide Locations

JLG Industries (Australia)  
P.O. Box 5119  
11 Bolwarra Road  
Port Macquarie  
N.S.W. 2444  
Australia

☎ +61 2 65 811111

📠 +61 2 65 813058

JLG Latino Americana Ltda.  
Rua Eng. Carlos Stevenson,  
80-Suite 71  
13092-310 Campinas-SP  
Brazil

☎ +55 19 3295 0407

📠 +55 19 3295 1025

JLG Industries (UK) Ltd  
Bentley House  
Bentley Avenue  
Middleton  
Greater Manchester  
M24 2GP - England

☎ +44 (0)161 654 1000

📠 +44 (0)161 654 1001

JLG France SAS  
Z.I. de Baulieu  
47400 Fauillet  
France

☎ +33 (0)5 53 88 31 70

📠 +33 (0)5 53 88 31 79

JLG Deutschland GmbH  
Max-Planck-Str. 21  
D - 27721 Ritterhude - Ihlpohl  
Germany

☎ +49 (0)421 69 350 20

📠 +49 (0)421 69 350 45

JLG Equipment Services Ltd.  
Rm 1107 Landmark North  
39 Lung Sum Avenue  
Sheung Shui N. T.  
Hong Kong

☎ (852) 2639 5783

📠 (852) 2639 5797

JLG Industries (Italia) s.r.l.  
Via Po. 22  
20010 Pregnana Milanese - MI  
Italy

☎ +39 029 359 5210

📠 +39 029 359 5845

Oshkosh-JLG Singapore  
Technology Equipment Pte  
Ltd  
29 Tuas Ave 4,  
Jurong Industrial Estate  
Singapore, 639379

☎ +65-6591 9030

📠 +65-6591 9031

Plataformas Elevadoras  
JLG Iberica, S.L.  
Trapadella, 2  
P.I. Castellbisbal Sur  
08755 Castellbisbal, Barcelona  
Spain

☎ +34 93 772 4700

📠 +34 93 771 1762

JLG Sverige AB  
Enkopingsvagen 150  
Box 704  
SE - 176 27 Jarfalla  
Sweden

☎ +46 (0)850 659 500

📠 +46 (0)850 659 534