



# Illustrated Parts Manual

## *Model* **15VPSP**

**3121822**

*May 29, 2013*



An Oshkosh Corporation Company



# REVISION LOG

September 5, 2000 - Original Issue Of Manual

March 27, 2003 - Revised (Manual edited to 0010566 Revision 22)

December 20, 2006 - Revised Manual

November 15, 2010 - Revised Manual

May 29, 2013 - Revised Manual

# REVISION LOG

# TABLE OF CONTENTS

FIGURE NO.	TITLE	PAGE NO.
<b>SECTION 1 - BASE</b>		<b>1-1</b>
1-1	BASE MOUNTED COMPONENTS INSTALLATION	1-2
1-2	REAR DRIVE ASSEMBLY	1-6
1-3	DRIVE MOTOR ASSEMBLY	1-10
1-4	JLG POTHOLE PROTECTION INSTALLATION	1-12
<b>SECTION 2 - CONTROLS</b>		<b>2-1</b>
2-1	GROUND CONTROL/POWER PACK INSTALLATION	2-2
2-2	PLATFORM CONTROLS AND CABLES INSTALLATIONS	2-6
2-3	BATTERY CHARGER ASSEMBLY	2-8
2-4	PUMP/MOTOR/TANK ASSEMBLY	2-10
2-5	CONTROL BOX ASSEMBLY	2-12
<b>SECTION 3 - MAST</b>		<b>3-1</b>
3-1	MAST ASSEMBLY - 15VPSP	3-2
3-2	MAST MOUNTING COMPONENTS	3-8
<b>SECTION 4 - PLATFORM</b>		<b>4-1</b>
4-1	PLATFORM INSTALLATION (FOLD DOWN SIDE RAILS)	4-2
4-2	PLATFORM INSTALLATION (FIXED SIDE RAILS)	4-6
4-3	PLATFORM INSTALLATION (QUICK CHANGE GULLWING)	4-10
4-4	PLATFORM INSTALLATION (QUICK CHANGE MOLDED)	4-14
<b>SECTION 5 - CYLINDER</b>		<b>5-1</b>
5-1	LIFT CYLINDER ASSEMBLY	5-2
<b>SECTION 6 - HYDRAULIC</b>		<b>6-1</b>
6-1	HYDRAULIC DIAGRAM	6-2
6-2	HYDRAULIC DIAGRAM (S/N 03620 TO PRESENT)	6-4
<b>SECTION 7 - ELECTRICAL</b>		<b>7-1</b>
7-1	ELECTRICAL SCHEMATIC (PRIOR TO S/N 03620)	7-2
7-2	ELECTRICAL SCHEMATIC (S/N 03620 TO PRESENT)	7-3
7-3	ELECTRICAL COMPONENTS INSTALLATION	7-4
<b>SECTION 8 - DECALS</b>		<b>8-1</b>
8-1	DECALS INSTALLATION	8-2
<b>SECTION 9 - RECOMMENDED SERVICE PARTS STOCK</b>		<b>9-1</b>
<b>SECTION 10 - SPECIAL OPTIONS</b>		<b>10-1</b>
<b>SECTION 11 - PART NUMBER INDEX</b>		<b>11-1</b>

# TABLE OF CONTENTS

FIGURE NO.

TITLE

PAGE NO.

# SECTION 1 BASE

TABLE OF CONTENTS		
FIGURE	DESCRIPTION	PAGE
1-1	BASE MOUNTED COMPONENTS INSTALLATION.....	1-2
1-2	REAR DRIVE ASSEMBLY .....	1-6
1-3	DRIVE MOTOR ASSEMBLY.....	1-10
1-4	JLG POTHOLE PROTECTION INSTALLATION.....	1-12

# SECTION 1 BASE

FIGURE 1-1. BASE MOUNTED COMPONENTS INSTALLATION

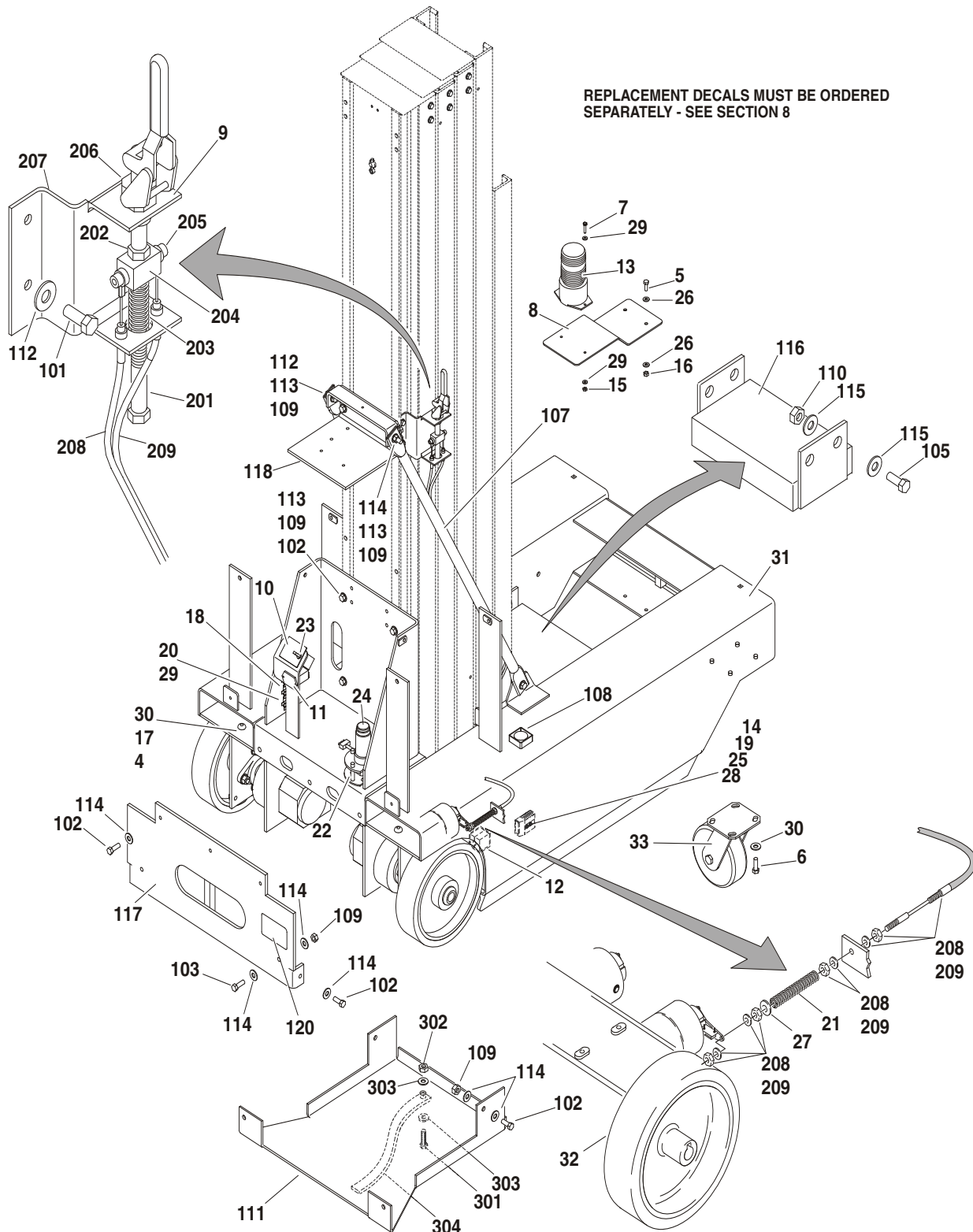



# SECTION 1 BASE

**FIGURE 1-1. BASE MOUNTED COMPONENTS INSTALLATION**

FIG & ITEM #	PART NUMBER	DESCRIPTION	QTY.	REV.
		<b>BASE ASSEMBLY</b>	Ref.	
	0270535	<b>15VPSP</b>	Ref.	A
1	0100011	Loctite #242 (Not Shown)	A/R	
2 to 3	Not Used			
4	0630446	Bolt 3/8"-16NC x 1" (Carriage)	4	
5	0641406	Bolt 1/4"-20NC x 3/4"	2	
6	0641609	Bolt 3/8"-16NC x 1 1/8"	8	
7	0721008	Screw	2	
8	0902583	Bracket, Beacon	1	
9	1060658	Cable, Brake Assembly (See Items for 201-211 Breakdown)	1	
10	1702923	Decal - Manual Descent	1	
11	2420165	Gauge, Hour Meter	1	
12	2820085	Insulate, Ferrite Bead	2	
13	2920146	Lamp, Beacon Assembly	1	
	7016319	Tube, Flash	1	
	7016372	Lens, Amber	1	
14	3310601	Locknut #6-32NC	8	
15	3311005	Locknut #10-24NC	2	
16	3311405	Locknut 1/4"-20NC	2	
17	3311605	Locknut 3/8"-16NC	4	
18	3740069	Relay, Power 24VDC	3	
19	3910620	Screw #6-32NC x 1 1/4"	4	
20	3911010	Screw	3	
21	4160164	Spring, Compression	2	
22	4300106	Stud, Grooved	4	
23	4360314	Switch, Toggle	1	
24	4360465	Switch, Tilt	1	
25	4460648	Receptacle - 2 Position	2	
26	4711400	Flatwasher 1/4" Narrow	4	
27	4740430	Washer, Fender	2	
28	4750600	Flatwasher #6	8	
29	4751000	Flatwasher #10 Wide	7	
30	4751600	Flatwasher 3/8" Wide	12	
31	4846087	Base Weldment	1	
32	4860175	Wheel, Rear Assembly	2	
	7019659	Steel Insert (1 Per Assembly)	2	
33	4860177	Wheel, Caster Assembly	2	
	7019660	Axle 1/2" x 3 1/4" (1 Per Assembly)	2	
	7019661	Wheel, Replacement (1 Per Assembly)	2	
	7019662	Caster without Wheel (1 Per Assembly)	2	
	7019663	Bearing, Wheel (1 Per Assembly)	2	

# SECTION 1 BASE

SECTION 1 BASE

**FIGURE 1-1. BASE MOUNTED COMPONENTS INSTALLATION (CONTINUED)**

FIG & ITEM #	PART NUMBER	DESCRIPTION	QTY.	REV.
		<b>MAST SUPPORT INSTALLATIONS</b>	Ref.	
	0259527	<b>PRIOR TO S/N 03620</b>	Ref.	C
	0271465	<b>S/N 03620 TO PRESENT</b>	Ref.	A
101	0641406	Bolt 1/4"-20NC x 3/4"	2	
102	0641608	Bolt 3/8"-16NC x 1"	20	
103	0641609	Bolt 3/8"-16NC x 1 1/8"	2	
104	0641612	Bolt 3/8"-16NC x 1 1/2"	1	
105	0641810	Bolt 1/2"-13NC x 1 1/4"	4	
106	Not Used			
107	0880139	Brace, Mast	2	
108	2420140	Gauge, Level (Prior to S/N 03620)	1	
109	3311605	Locknut 3/8"-16NC	18	
110	3311805	Locknut 1/2"-13NC	4	
111	3570172	Cover, Drive Motors	1	
112	4711400	Flatwasher 1/4" Narrow	2	
113	4711600	Flatwasher 3/8" Narrow	28	
114	4751600	Flatwasher 3/8" Wide	13	
115	4751800	Flatwasher 1/2" Wide	8	
116	4845291	Weldment, Counterweight	1	
117	4845474	Weldment, Rear Plate	1	
118	4846173	Weldment, Ground Control	1	
119	4240033	Wire, Tie (Not Shown)	2	
120	1704582	Decal - Manual Descent (S/N 03620 to Present)	1	
	1060658	<b>BRAKE CABLE ASSEMBLY</b>	Ref.	3/C
201	0641528	Bolt 5/16"-18NC x 3 1/2"	1	
202	3311501	Nut 5/16"-18NC	1	
203	4160166	Spring, Compression	1	
204	0561284	Bar, Aluminum	1	
205	3900248	Bolt 1/4"-20NC x 1/4"	2	
206	2560150	Handle, Brake Cable	1	
207	3570382	Bracket, Brake Cable	1	
208	1060661	Cable, Brake	1	
209	1060662	Cable, Brake	1	
210	0100019	Loctite #271 (Not Shown)	A/R	
211	0100035	Loctite #222 (Not Shown)	A/R	
	0270352	<b>STATIC STRAP INSTALLATION</b>	Ref.	A
301	0641608	Bolt 3/8"-16NC x 1"	1	
302	3311605	Nut 3/8"-16NC	1	
303	4751600	Flatwasher 3/8"	2	
304	4240084	Strap, Static	1	

# SECTION 1 BASE

FIGURE 1-1. BASE MOUNTED COMPONENTS INSTALLATION (CONTINUED)

FIG & ITEM #	PART NUMBER	DESCRIPTION	QTY.	REV.

**S  
E  
C  
T  
I  
O  
N  
  
1  
  
B  
A  
S  
E**

# SECTION 1 BASE

FIGURE 1-2. REAR DRIVE ASSEMBLY

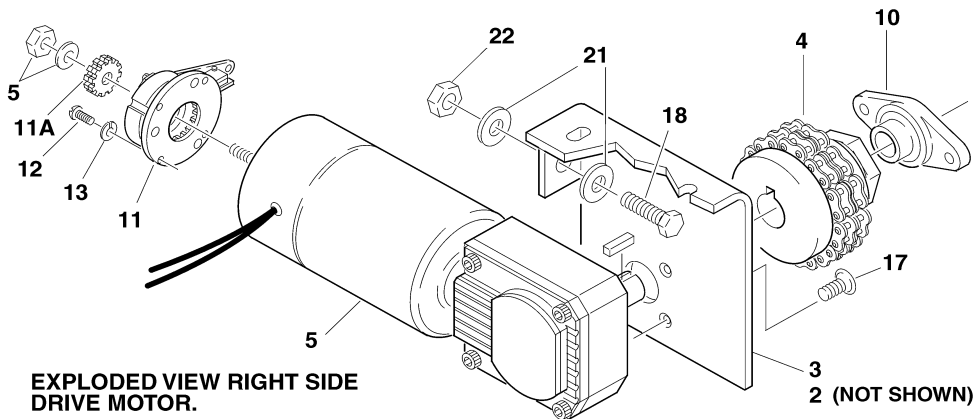
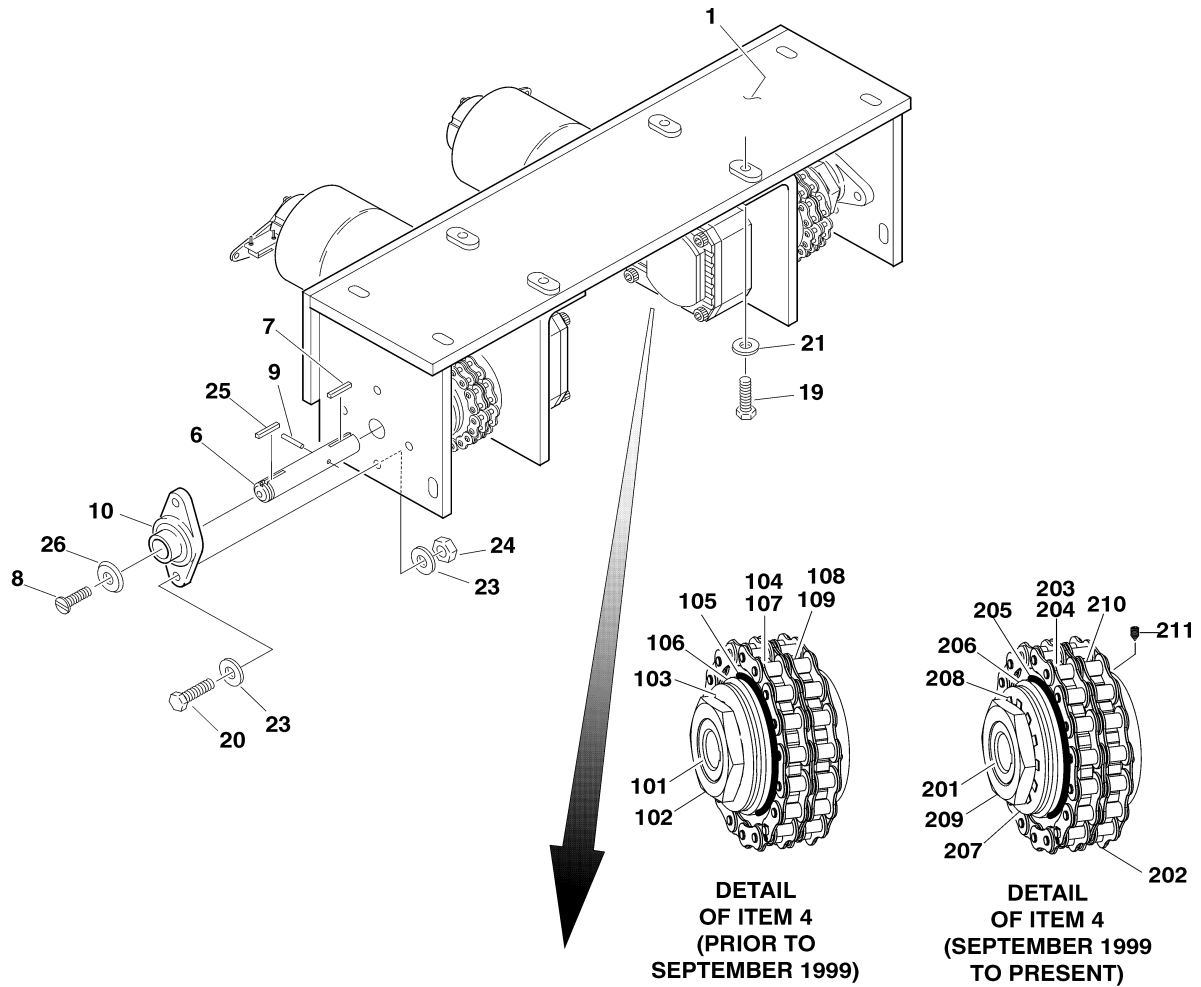

# SECTION 1 BASE

**FIGURE 1-2. REAR DRIVE ASSEMBLY**

FIG & ITEM #	PART NUMBER	DESCRIPTION	QTY.	REV.
	0258718	<b>REAR DRIVE ASSEMBLY</b>	Ref.	1/B
1	4845473	Weldment, Drive	1	
2	3570168	Plate, Motor Mount (Left)	1	
3	3570169	Plate, Motor Mount (Right)	1	
4	1400126	Clutch, Torque Limiting Options: Dalton Brand Clutch, Torque Limiting (See Items 101-109 for Breakdown) (Prior to September 1999) EPT Brand Clutch, Torque Limiting (See Items 201-211 for Breakdown) (September 1999 to Present)	2	
5	3160234	Wheel Drive Motor Assembly (See Figure 1-3 for Breakdown)	2	
6	4040268	Shaft, Drive	2	
7	2860027	Key, Clutch	2	
8	0741609	Bolt 3/8"-16NC x 1 1/8"	2	
9	3440520	Pin, Roll	2	
10	0440221	Bearing, Flange	4	
11	0256851	Brake Assembly	2	
	7014117	Switch, Micro (1 Per Assembly)	2	
	7014118	Disc, Friction (1 Per Assembly)	2	
11A	7014119	Gear (1 Per Assembly)	2	
	7014120	Setscrew (2 Per Assembly)	4	
12	3930808	Bolt #8-32NC x 1/2"	8	
13	4750800	Flatwasher #8	8	
14	0100035	Loctite #222 (Not Shown)	A/R	
15	0100011	Loctite #242 (Not Shown)	A/R	
16	0100019	Loctite #272 (Not Shown)	A/R	
17	3900221	Bolt 5/16"-18NC x 3/4"	6	
18	0641610	Bolt 3/8"-16NC x 1 1/4"	2	
19	0641609	Bolt 3/8"-16NC x 1 1/8"	4	
20	0641711	Bolt 7/16"-14NC x 1 3/8"	8	
21	4751600	Flatwasher 3/8"	8	
22	3311605	Locknut 3/8"-16NC	2	
23	4711700	Flatwasher 7/16"	16	
24	3311705	Locknut 7/16"-14NC	8	
25	2860029	Key, Wheel	2	
26	4740478	Washer, Wheel Retainer	2	
	1400126	<b>TORQUE LIMITER CLUTCH ASSEMBLY (DALTON BRAND) (PRIOR TO SEPTEMBER 1999)</b>	Ref.	A
101	7016689	Hub	1	
102	7016683	Nut, Adjusting	1	
103	7016684	Spring	1	
104	7016685	Bearing	1	
105	7016691	Facing, Friction	2	
106	7016690	Plate, Pressure	1	
107	7016686	Sprocket	1	
108	7016687	Coupling, Chain	1	

# SECTION 1 BASE

**FIGURE 1-2. REAR DRIVE ASSEMBLY (CONTINUED)**

FIG & ITEM #	PART NUMBER	DESCRIPTION	QTY.	REV.
109	7016688	Sprocket	1	
	1400126	<b>TORQUE LIMITER CLUTCH ASSEMBLY (EPT BRAND) (SEPTEMBER 1999 TO PRESENT)</b>	Ref.	C
201	7023351	Hub	1	
202	7023352	Chain	1	
203	7023353	Sprocket	1	
204	7023354	Bushing	1	
205	7023355	Facing, Friction	2	
206	7023356	Plate, Pressure	1	
207	7023357	Disc, Spring	3	
208	7023358	Lockwasher, Tabbed	1	
209	7023359	Nut, Adjusting	1	
210	7023360	Sprocket	1	
211	7023361	Setscrew	1	

**SECTION 1 BASE**

# SECTION 1 BASE

FIGURE 1-2. REAR DRIVE ASSEMBLY (CONTINUED)

FIG & ITEM #	PART NUMBER	DESCRIPTION	QTY.	REV.

**S  
E  
C  
T  
I  
O  
N  
  
1  
  
B  
A  
S  
E**

# SECTION 1 BASE

FIGURE 1-3. DRIVE MOTOR ASSEMBLY

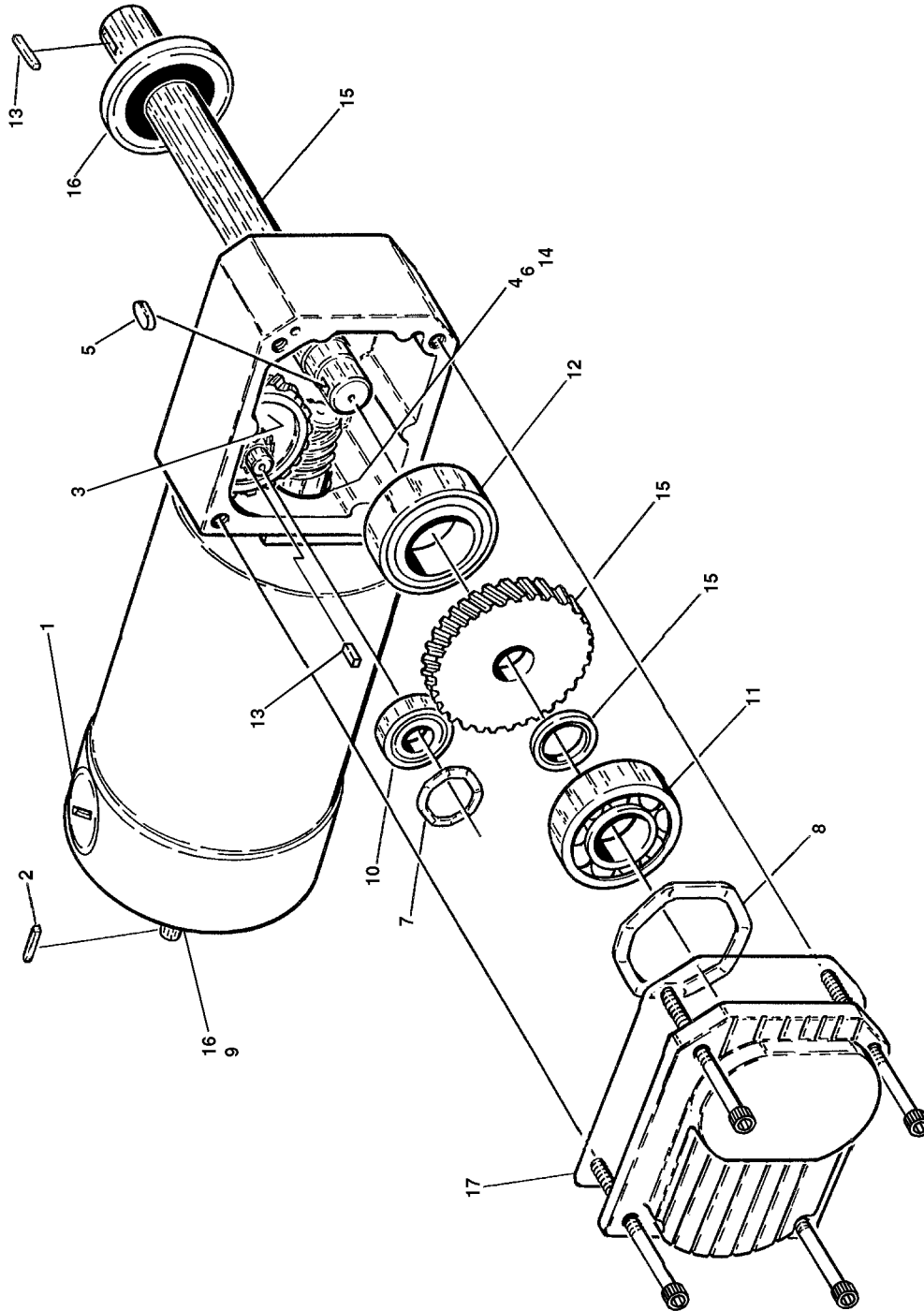



# SECTION 1 BASE

**FIGURE 1-3. DRIVE MOTOR ASSEMBLY**

FIG & ITEM #	PART NUMBER	DESCRIPTION	QTY.	REV.
	3160234	<b>DRIVE MOTOR ASSEMBLY</b>	Ref.	B
1	7018000	Brush Kit	1	
2	7018001	Key, Shaft	1	
3	7018002	Gear and Pinion Assembly	1	
4	7018005	Ring, Retaining	1	
5	7018007	Key, Shaft	1	
6	7018008	Bearing	1	
7	7018009	Washer, Wave	1	
8	7018010	Washer, Wave	1	
9	7018011	Washer, Wave	1	
10	7018012	Bearing 32mm x 12mm x 10mm	2	
11	7018013	Bearing 47mm x 20mm x 14mm	1	
12	7018014	Bearing 47mm x 25mm x 12mm	1	
13	7018015	Shaft, Key	1	
14	7018018	Seal, Lip	2	
15	7018019	Gear and Drive Shaft	1	
16	7018027	Bearing	1	
17	7018028	O-Ring	1	

# SECTION 1 BASE

**FIGURE 1-4. JLG POTHOLE PROTECTION INSTALLATION**

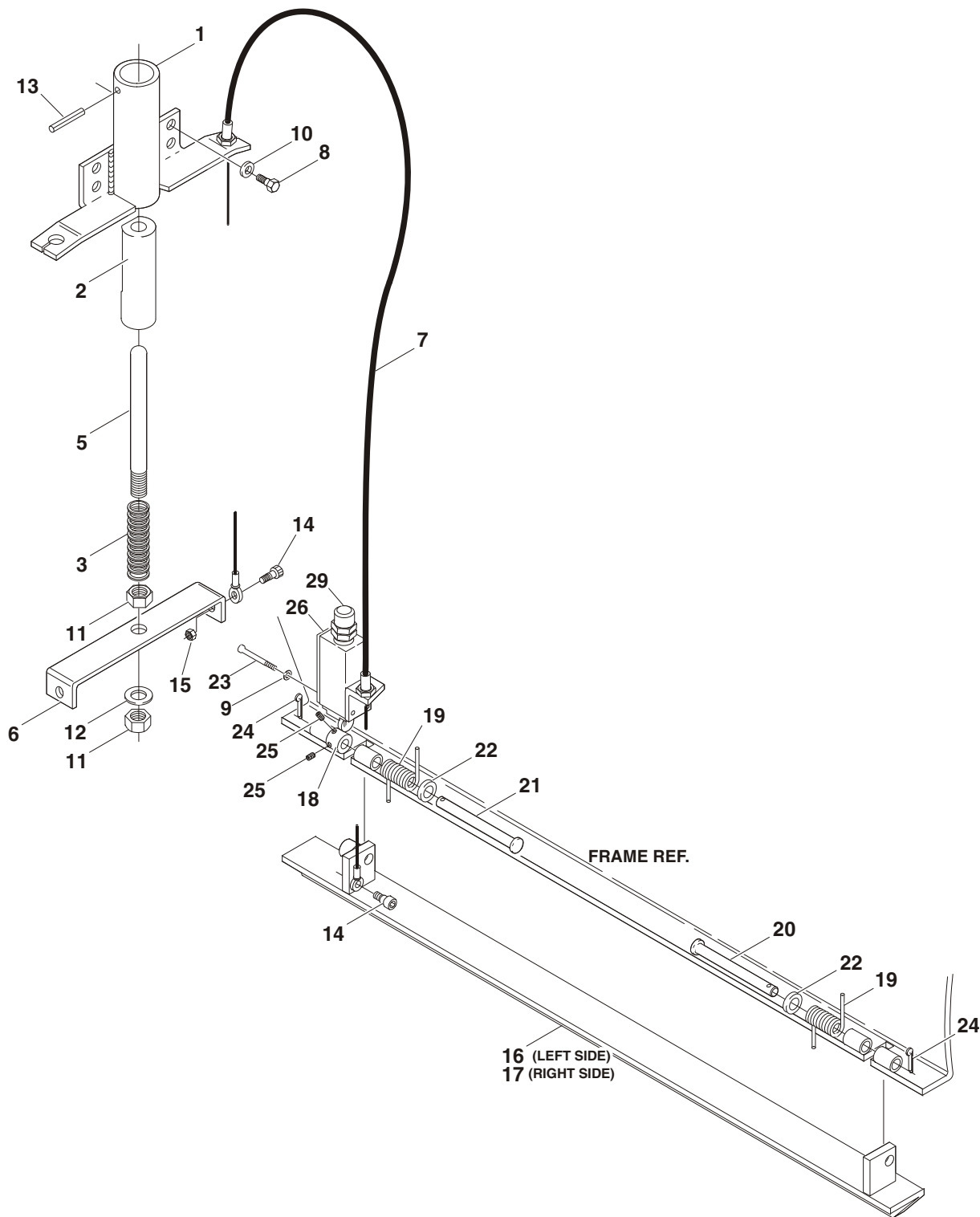

# SECTION 1 BASE

**FIGURE 1-4. JLG POTHOLE PROTECTION INSTALLATION**

FIG & ITEM #	PART NUMBER	DESCRIPTION	QTY.	REV.
	0257490	<b>JLG POTHOLE PROTECTION INSTALLATION</b>	Ref.	2/B
1	4845507	Actuator Weldment	1	
2	4567203	Tube, Sleeve	1	
3	4160160	Spring, Compression	1	
4	3020022	Grease, Lithium (with PTFE) (Not Shown)	A/R	
5	3841343	Rod, Actuator	1	
6	3570230	Plate, Cable Attach	1	
7	1060649	Cable	2	
8	0641405	Bolt 1/4"-20NC x 5/8"	4	
9	4750600	Flatwasher #6	4	
10	4711400	Flatwasher 1/4" Narrow	4	
11	3312002	Nut, Jam 5/8"-11NC	2	
12	4712000	Flatwasher 5/8" Narrow	1	
13	3440418	Rollpin 1/8" 1 1/8"	1	
14	3900202	Screw, Shoulder 1/4"-20NC x 1/4"	4	
15	3311005	Locknut #10-24NC	2	
16	4845508	Bar, Pothole (Left Side)	1	
17	4845509	Bar, Pothole (Right Side)	1	
18	1100103	Cam	2	
19	4160162	Spring, Torsion	4	
20	3430630	Pin, Clevis 3/8" x 3 3/4"	2	
21	3430638	Pin, Clevis 3/8" x 4 3/4"	2	
22	4751600	Flatwasher 3/8"	4	
23	3910620	Screw #6-32NC x 1 1/4"	4	
24	3450403	Pin, Cotter 1/8" x 3/4"	4	
25	3900249	Setscrew #10-32NC x 3/16"	4	
26	4360456	Switch, Limit	2	
27	0100035	Loctite #222 (Not Shown)	A/R	
28	0100011	Loctite #242 (Not Shown)	A/R	
29	4460662	Connector, Strain Relief	2	

# SECTION 1 BASE

FIGURE 1-4. JLG POTHOLE PROTECTION INSTALLATION (CONTINUED)

FIG & ITEM #	PART NUMBER	DESCRIPTION	QTY.	REV.

**S  
E  
C  
T  
I  
O  
N  
  
1  
  
B  
A  
S  
E**

# SECTION 2 CONTROLS

TABLE OF CONTENTS		
FIGURE	DESCRIPTION	PAGE
2-1	GROUND CONTROL/POWER PACK INSTALLATIONS . . . . .	2-2
2-2	PLATFORM CONTROLS AND CABLES INSTALLATIONS . . . . .	2-6
2-3	BATTERY CHARGER ASSEMBLY . . . . .	2-8
2-4	PUMP/MOTOR/TANK ASSEMBLY . . . . .	2-10
2-5	CONTROL BOX ASSEMBLY . . . . .	2-12

# SECTION 2 CONTROLS

FIGURE 2-1. GROUND CONTROL/POWER PACK INSTALLATION

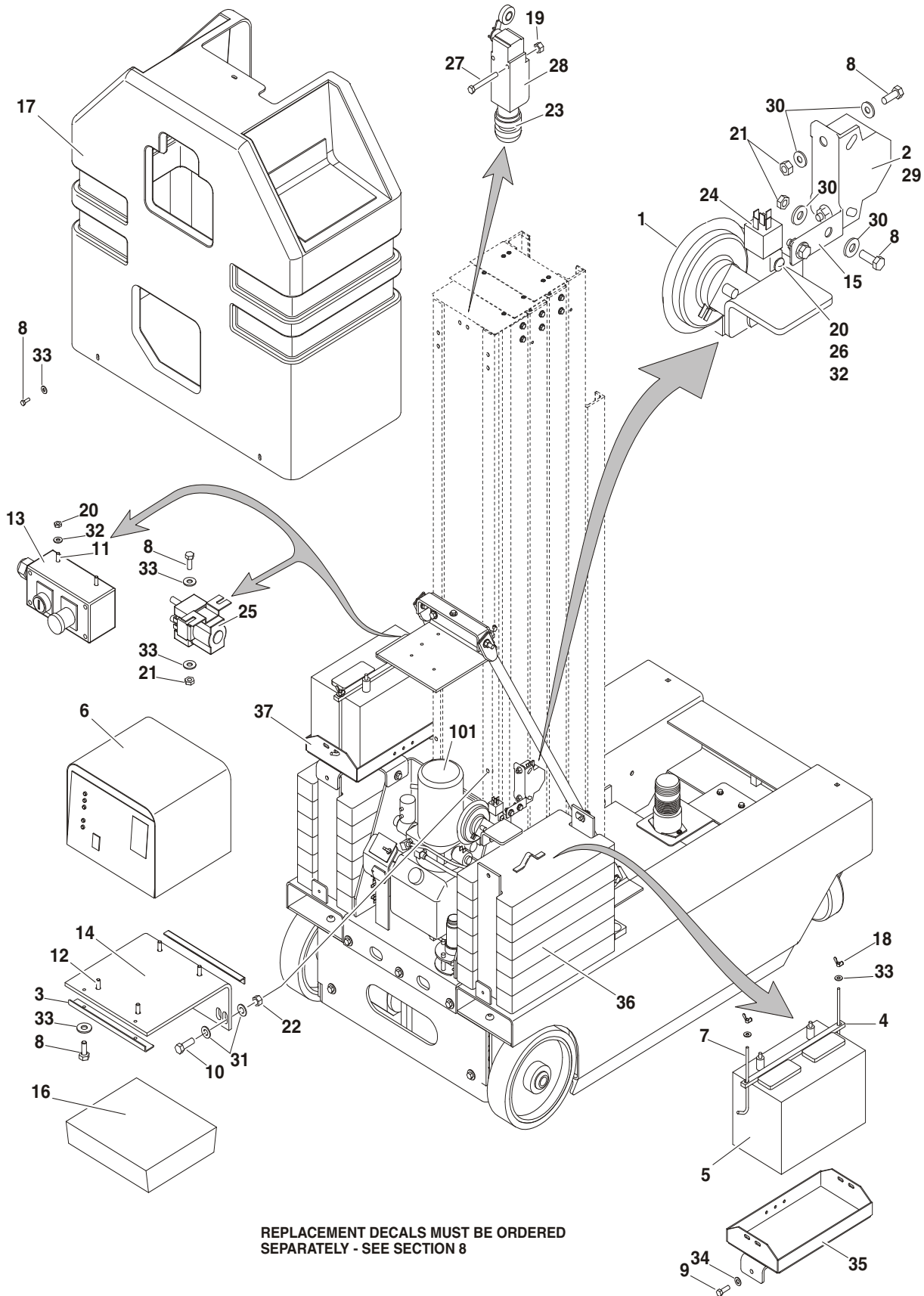

SECTION 2 CONTROLS

# SECTION 2 CONTROLS

**FIGURE 2-1. GROUND CONTROL/POWER PACK INSTALLATION**

FIG & ITEM #	PART NUMBER	DESCRIPTION	QTY.	REV.
	0259528	<b>GROUND CONTROL/POWER PACK INSTALLATION</b>	Ref.	D
1	0140022	Alarm, Horn	1	
2	0140033	Alarm	1	
3	0181857	Angle, Controller Mount	1	
4	0362658	Bar, Battery Hold Down	2	
5	0400122	Battery	2	
6	0400164	Charger, Battery 120VAC (See Figure 2-3 for Breakdown)	1	
7	0630504	Bolt, Battery Hold Down	4	
8	0641406	Bolt 1/4"-20NC x 3/4"	13	
9	0641508	Bolt 5/16"-18NC x 1"	6	
10	0641609	Bolt 3/8"-16NC x 1 1/8"	2	
11	0721006	Screw	2	
12	0741407	Bolt 1/4"-20NC x 7/8"	4	
13	0861330	Ground Control Box	1	
	7020094	Lid	1	
	4360469	Switch, Key	1	
	2860030	Key, Replacement	1	
	7020078	Switch, Push-Pull (Stop)	1	
	7020093	Screw m3 x 25	4	
	7020097	Legend Plate, "Power/Off/On"	1	
	7020096	Legend Plate, "Stop"	1	
	4460633	Connector, Strain Relief	1	
14	0902250	Bracket, Charger/Controller	1	
15	0902356	Bracket, Alarm	1	
16	1600305	Controller	1	
17	2680483	Hood	1	
17A	2700080	Hook	2	
18	3300202	Wingnut	4	
19	3311001	Nut #10-24NC	2	
20	3311005	Locknut #10-24NC	3	
21	3311405	Locknut 1/4"-20NC	6	
22	3311605	Locknut 3/8"-16NC	2	
23	3520166	Plug	1	
24	3740069	Relay, Power 24VDC	1	
25	3740130	Relay, 100Amp	1	
26	3911010	Screw	1	
27	3911024	Screw	2	
28	4360437	Switch, Limit	1	
29	4460685	Terminal, Stud Mount Tab	4	
30	4711400	Flatwasher 1/4" Narrow	8	
31	4711600	Flatwasher 3/8" Narrow	4	
32	4751000	Flatwasher #10 Wide	6	
33	4751400	Flatwasher 1/4" Wide	15	
34	4751500	Flatwasher 5/16" Wide	6	
35	4845875	Weldment, Battery Box (Left)	1	
36	4845876	Weldment, Counterweight	2	
37	4845878	Weldment, Battery Box (Right)	1	

# SECTION 2 CONTROLS

**FIGURE 2-1. GROUND CONTROL/POWER PACK INSTALLATION**

**SECTION 2 CONTROLS**

FIG & ITEM #	PART NUMBER	DESCRIPTION	QTY.	REV.
101	0259774	<b>POWER PACK INSTALLATIONS</b>	Ref.	
	0271466	<b>PRIOR TO S/N 03620</b>	Ref.	A
		<b>S/N 03620 TO PRESENT</b>	Ref.	A
	3600254	Pump/Motor 24VDC (See Figure 2-4 for Breakdown)	1	
	0641606	Bolt 3/8"-16NC x 3/4"	4	
	0741605	Bolt 3/8"-16NC x 5/8"	2	
	4751600	Flatwasher 3/8" Wide	4	



# SECTION 2 CONTROLS

FIGURE 2-1. GROUND CONTROL/POWER PACK INSTALLATION

FIG & ITEM #	PART NUMBER	DESCRIPTION	QTY.	REV.

**S  
E  
C  
T  
I  
O  
N  
  
2  
  
C  
O  
N  
T  
R  
O  
L  
S**

# SECTION 2 CONTROLS

FIGURE 2-2. PLATFORM CONTROLS AND CABLES INSTALLATIONS

SECTION 2 CONTROLS

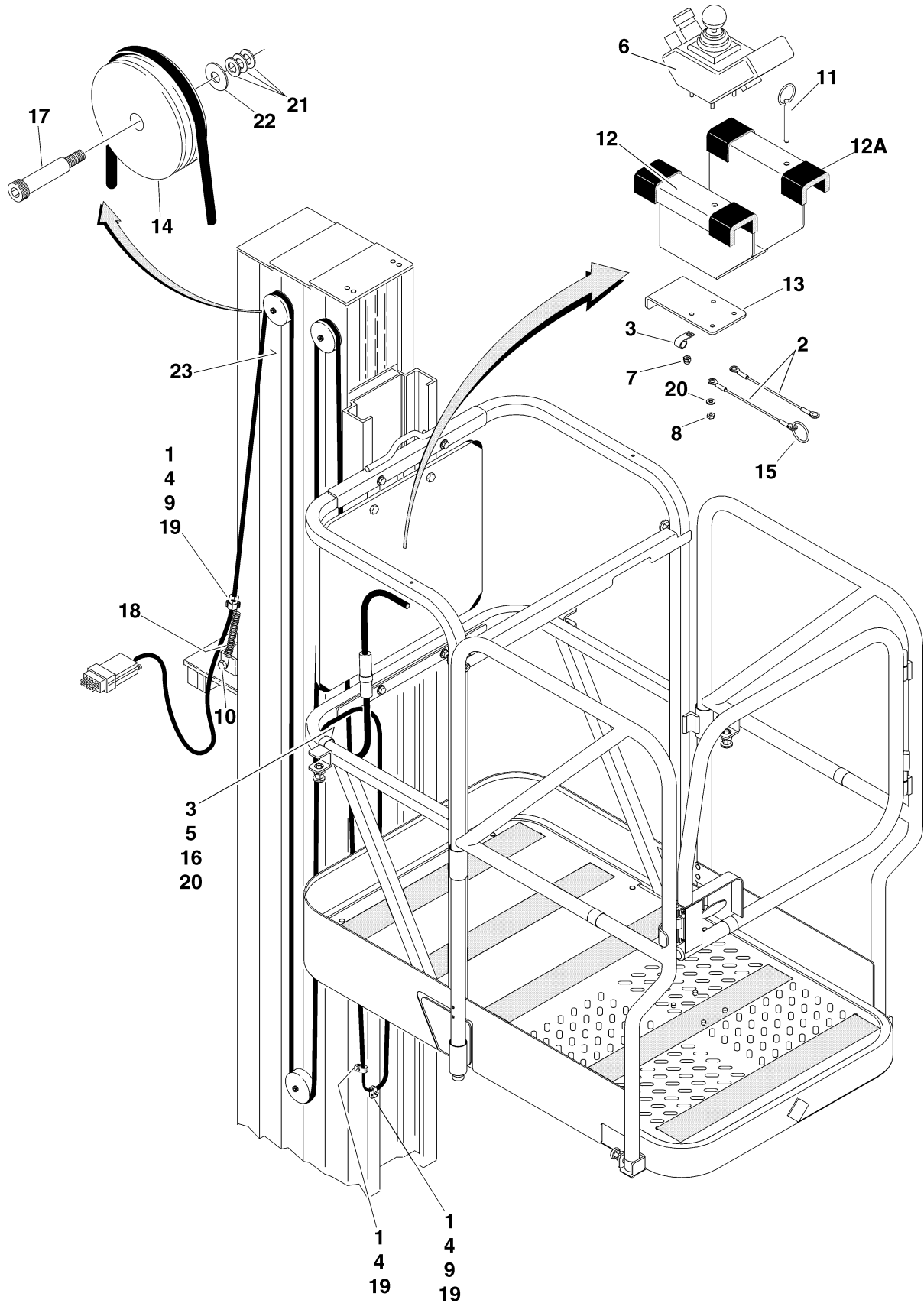

# SECTION 2 CONTROLS

**FIGURE 2-2. PLATFORM CONTROLS AND CABLES INSTALLATIONS**

FIG & ITEM #	PART NUMBER	DESCRIPTION	QTY.	REV.
		<b>PLATFORM CONTROLS AND CABLES INSTALLATIONS</b>	Ref.	
	0259769	<b>15 VPSP</b>	Ref.	B
1	0641410	Bolt 1/4"-20NC x 1 1/4"	3	
2	1060380	Cable, Lanyard	2	
3	1320043	Clamp, Cable	2	
4	1320149	Clamp, Hose	3	
5	1380132	Clip, Gripper	1	
6	1600304	Controller, Joystick	1	
7	3300417	Nut, Acorn #8-32NC	4	
8	3310801	Nut #8-32NC	8	
9	3311405	Locknut 1/4"-20NC	2	
10	3311605	Locknut 3/8"-16NC	1	
11	3422657	Pin, Quick Release	1	
12	3570680	Bracket, Joystick	1	
12A		Pad, Rubber Options:	A/R	
	7020075	RH Side Pad	2	
	7020076	LH Side Pad	2	
13	3570737	Bracket, Joystick	1	
14	3580231	Pulley, Sheave	3	
15	3760170	Ring, Split	1	
16	3820024	Rivet	1	
17	3900200	Screw, Shoulder	3	
18	4160130	Spring, Extension	1	
19	4711400	Flatwasher 1/4" Narrow	5	
20	4750800	Flatwasher #8 Wide	5	
21	4751000	Flatwasher #10 Wide	12	
22	4751500	Flatwasher 5/16" Wide	3	
23	4922203	Harness, Platform Control	1	

**SECTION 2 CONTROLS**

# SECTION 2 CONTROLS

FIGURE 2-3. BATTERY CHARGER ASSEMBLY

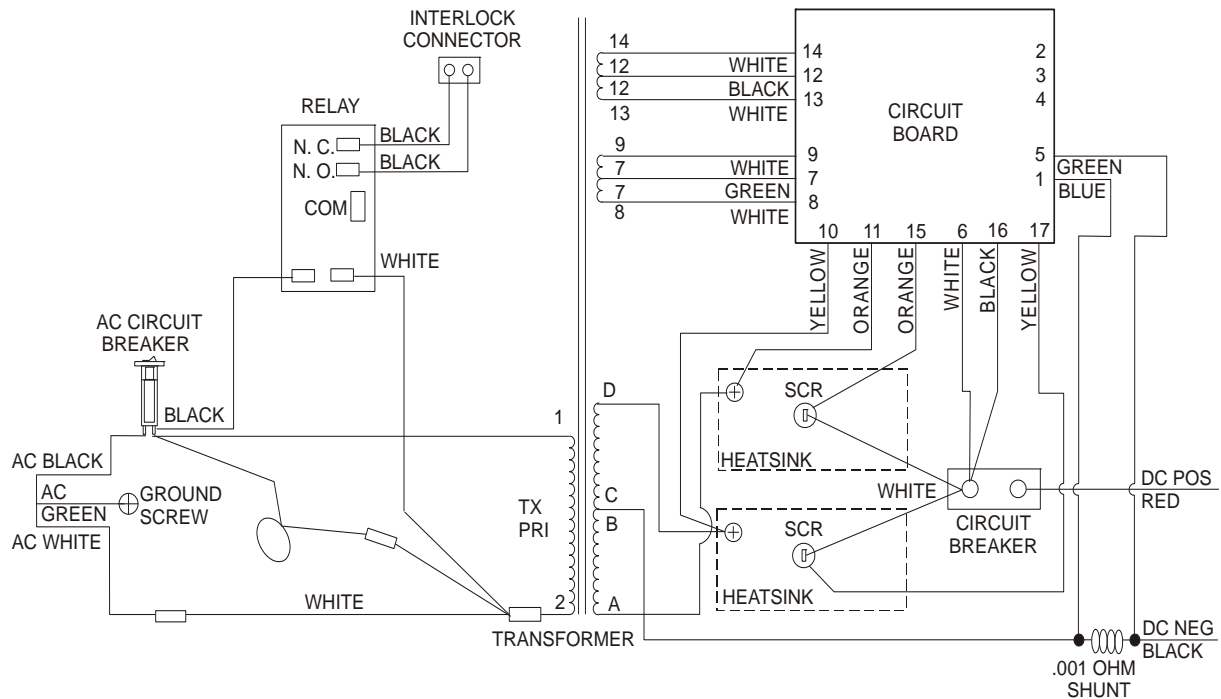
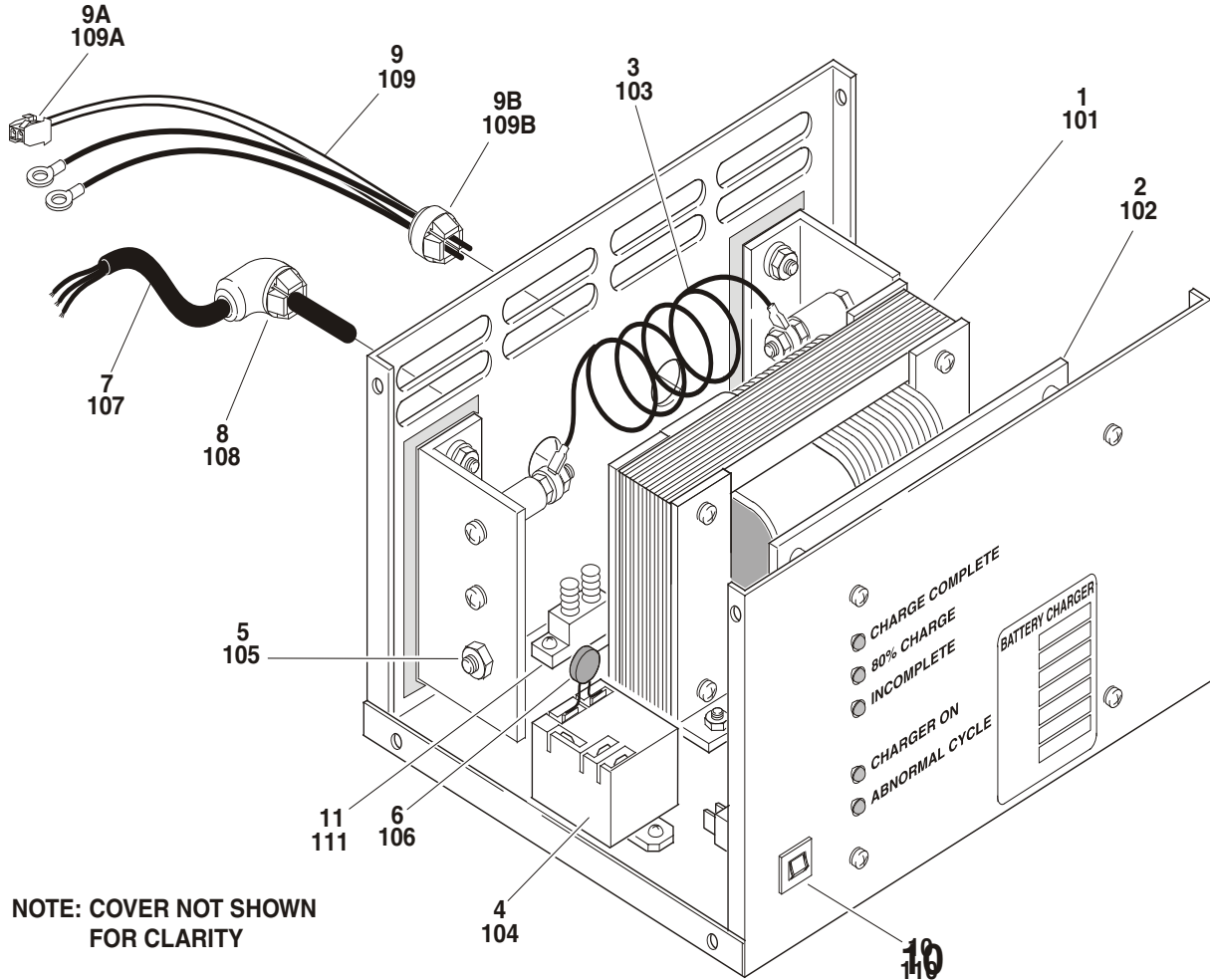

# SECTION 2 CONTROLS

**FIGURE 2-3. BATTERY CHARGER ASSEMBLY**

FIG & ITEM #	PART NUMBER	DESCRIPTION	QTY.	REV.
		<b>BATTERY CHARGER ASSEMBLIES</b>	Ref.	
	0400157	<b>120/240 VOLT/50HZ</b>	Ref.	B
1	7020620	Transformer (was p/n 7018551)	1	
2	7018562	Card, Circuit	1	
3	7018554	Shunt Assembly	1	
4	7018564	Relay, Interlock	1	
5	7018555	SCR Rectifier	2	
6	7018589	Varistor (was p/n 7018537)	1	
7	7018556	AC Cord Assembly	1	
8	7011528	Connector, Strain Relief - 90°	1	
9	7018567	DC Harness Assembly	1	
9A	4460424	Connector, Male - 2 Position	1	
	4460267	Pin, Male	2	
9B	7011528	Connector, Strain Relief	1	
10	7018557	Breaker, Circuit - AC	2	
11	7011509	Breaker, Circuit - DC	1	
12	7018586	Switch, Selector	2	
13	7011649	Relay (Not Shown)	1	
	0400166	<b>240 VOLT/50HZ</b>	Ref.	B
101	7018551	Transformer	1	
102	7018562	Card, Circuit	1	
103	7018554	Shunt Assembly	1	
104	7018563	Relay, Interlock	1	
105	7018555	SCR Rectifier	2	
106	7018537	Varistor	1	
107	7018556	AC Cord Assembly	1	
108	7011528	Connector, Strain Relief - 90°	1	
109	7018567	DC Harness Assembly	1	
109A	4460424	Connector, Male - 2 Position	1	
	4460267	Pin, Male	2	
109B	7011528	Connector, Strain Relief	1	
110	7018557	Breaker, Circuit - AC	1	
111	7011509	Breaker, Circuit - DC	1	

# SECTION 2 CONTROLS

FIGURE 2-4. PUMP/MOTOR/TANK ASSEMBLY

SECTION 2 CONTROLS

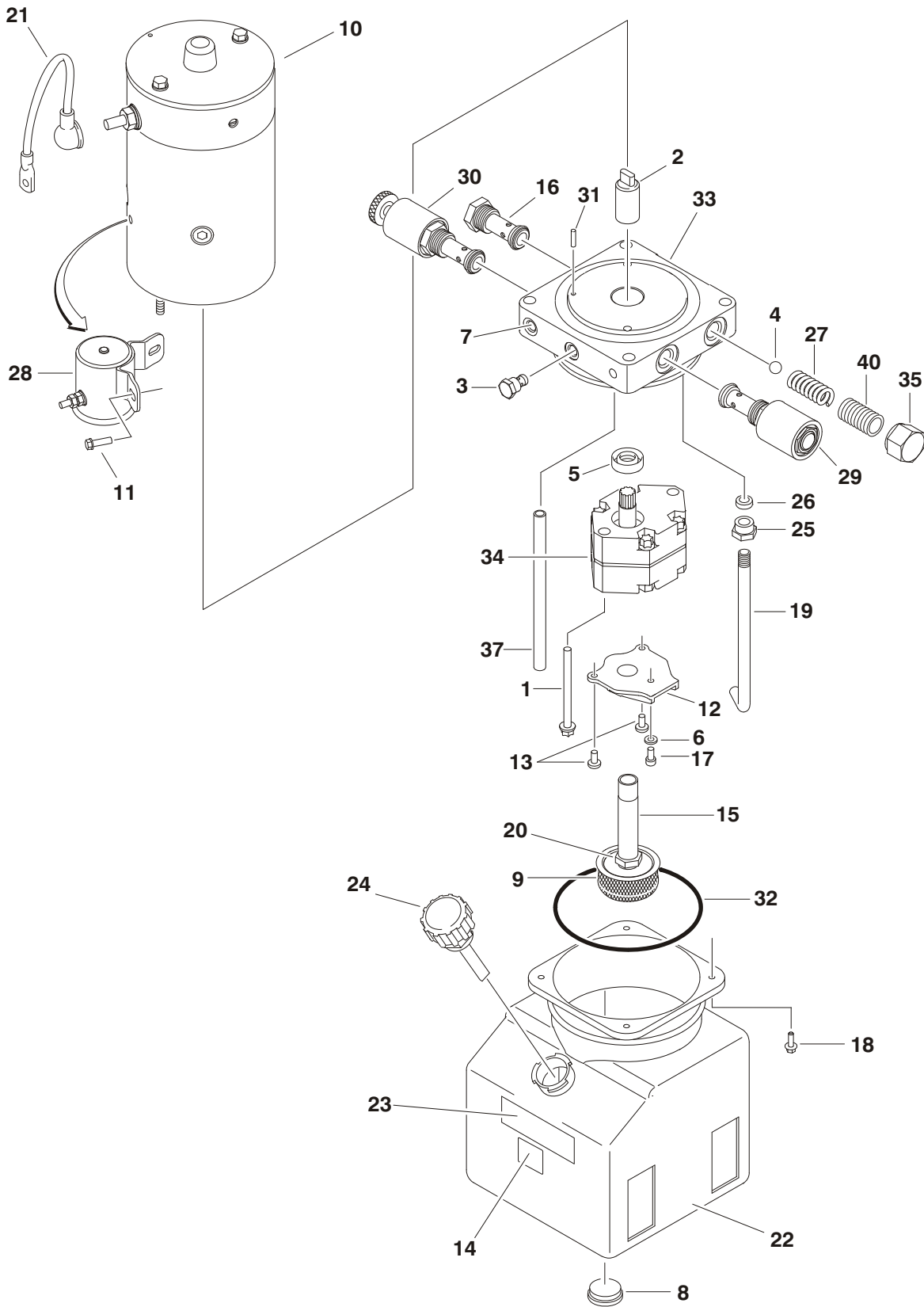

# SECTION 2 CONTROLS

**FIGURE 2-4. PUMP/MOTOR/TANK ASSEMBLY**

FIG & ITEM #	PART NUMBER	DESCRIPTION	QTY.	REV.
	3600254	<b>PUMP/MOTOR/TANK ASSEMBLY</b>	Ref.	C
1	7013713	Bolt 5/16"-24NF x 2 3/4"	2	
2	7016735	Coupling	1	
3	7013714	Plug	1	
4	7013715	Ball	1	
5	7013716	Seal, Shaft	1	
6	7013717	Washer	1	
7	Not Serviced	Plug, Shipping	1	
8	7013722	Magnet	1	
9	7013723	Filter - 149 Micron	1	
10	7016710	Motor	1	
	7016718	Brush Kit	1	
11	7013758	Screw 1/4"-20NC	2	
12	7013727	Cover	1	
13	7013728	Screw M6 x 1	2	
14	Not Serviced	Nameplate - Serial Number	1	
15	7016719	Pipe, PCV	1	
16	7013708	Valve, Check Cartridge	1	
17	7016720	Bolt 5/16"-18NC x 1"	1	
18	7016721	Bolt #12-24NC x 1/2"	4	
19	7013791	Tube, Return	1	
20	7016722	Nut 3/8"	1	
21	7013759	Cable, Electrical	1	
22	7016712	Tank, Plastic	1	
23	7016713	Decal - Tank Fill Line	1	
24	7016714	Breather	1	
25	7013792	Nut, Compression	1	
26	7013793	Sleeve, Compression	1	
27	7013733	Spring	1	
28	7016711	Solenoid, Start	1	
29	7022205	Valve, Solenoid Cartridge	1	
	7022206	Coil	1	
30	7016723	Valve, Manual Override Cartridge	1	
31	7013766	Pin	1	
32	7013743	O-Ring	1	
33	Not Serviced	Endhead	1	
34	7017717	Pump Assembly	1	
	7013701	Seal Kit - Pump	1	
35	7013750	Cap	1	
36	7013720	Plug 1/16"	2	
37	7016724	Tube	1	
38 to 39	Not Used			
40	7013770	Valve, Screw Adjustment	1	

**SECTION 2 CONTROLS**

# SECTION 2 CONTROLS

FIGURE 2-5. CONTROL BOX ASSEMBLY

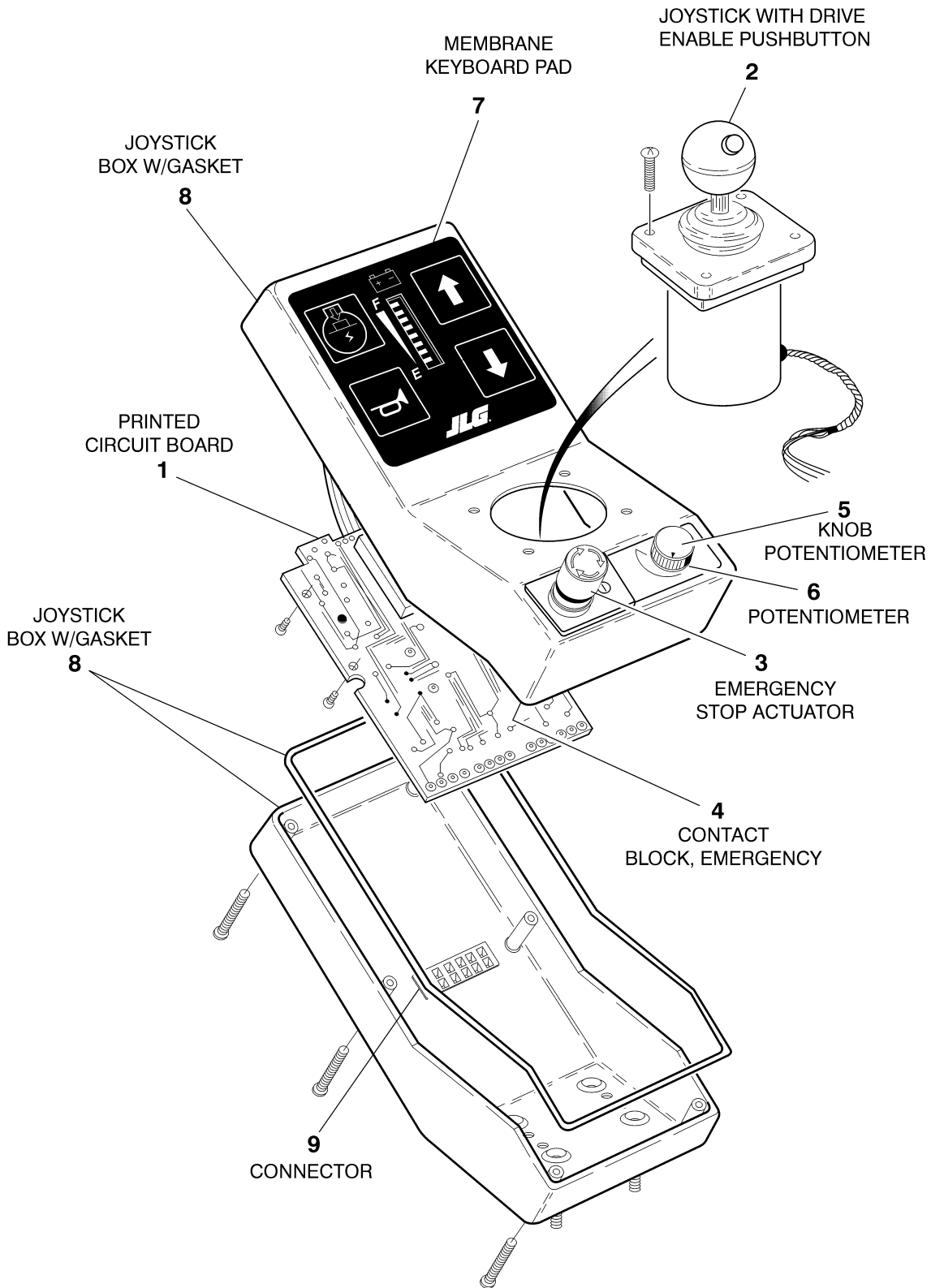

SECTION 2 CONTROLS



# SECTION 2 CONTROLS

**FIGURE 2-5. CONTROL BOX ASSEMBLY**

FIG & ITEM #	PART NUMBER	DESCRIPTION	QTY.	REV.
	1600304	<b>CONTROL BOX ASSEMBLY</b>	Ref.	A
1	7020147	Printed Circuit Board	1	
2	7023201	Joystick	1	
3	7020144	Emergency Stop Actuator	1	
4	7020145	Contact Block, Emergency Stop	1	
5	7020143	Knob Potentiometer	1	
6	7020142	Potentiometer	1	
7	7023202	Membrane Keyboard Pad	1	
8	7020139	Joystick Box W/Gasket	1	
9	7026038	Connector, 12 Position	1	
	7026039	Pin	12	

**SECTION 2 CONTROLS**

# SECTION 2 CONTROLS

FIGURE 2-5. CONTROL BOX ASSEMBLY (CONTINUED)

**SECTION 2 CONTROLS**

FIG & ITEM #	PART NUMBER	DESCRIPTION	QTY.	REV.

# SECTION 3 MAST

TABLE OF CONTENTS		
FIGURE	DESCRIPTION	PAGE
3-1	MAST ASSEMBLY - 15VPSP .....	3-2
3-2	MAST MOUNTING COMPONENTS.....	3-8

**S  
E  
C  
T  
I  
O  
N  
  
3  
  
M  
A  
S  
T**

# SECTION 3 MAST

## FIGURE 3-1. MAST ASSEMBLY - 15VPSP

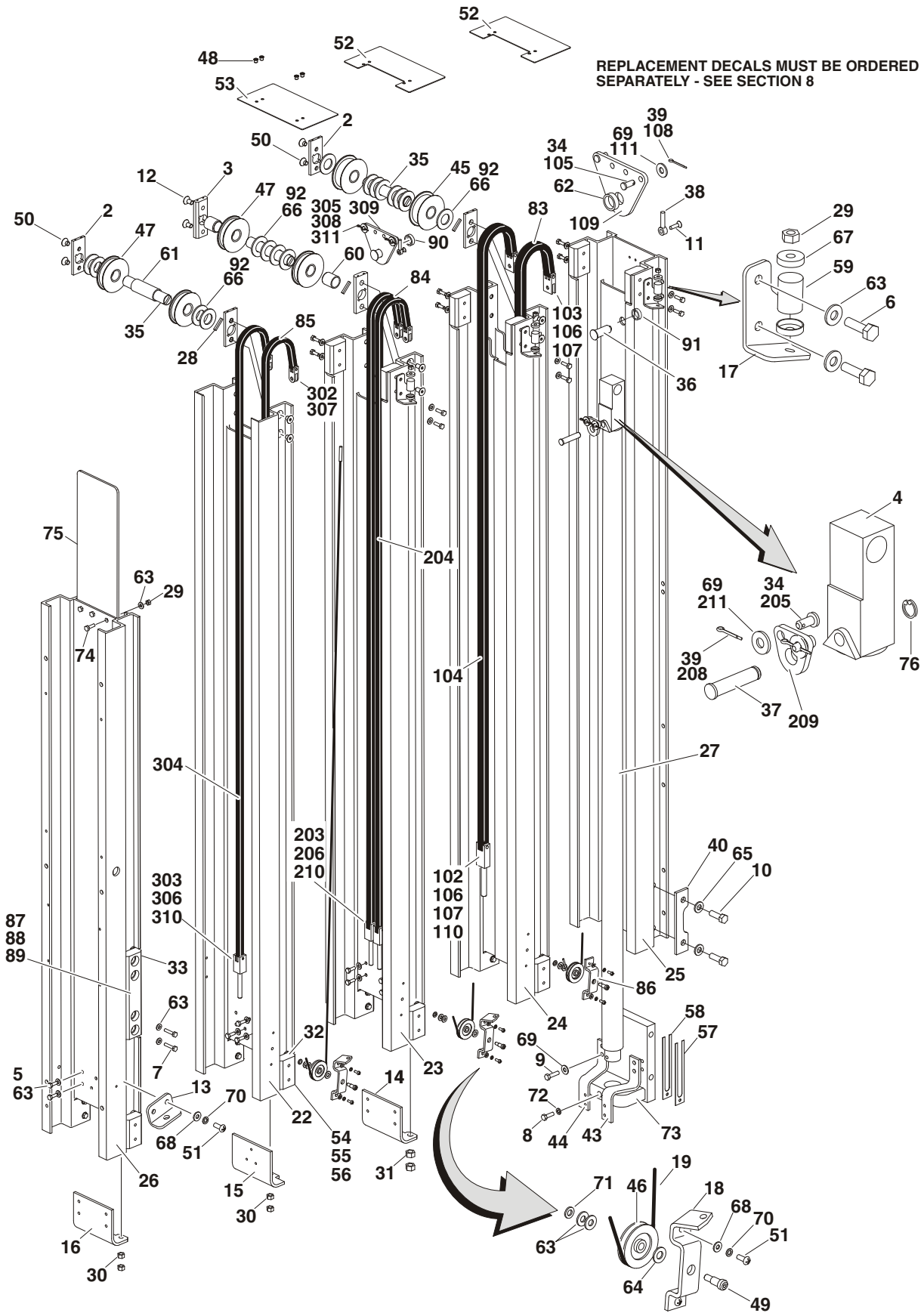

SECTION 3 MAST

# SECTION 3 MAST

**FIGURE 3-1. MAST ASSEMBLY - 15VPSP**

FIG & ITEM #	PART NUMBER	DESCRIPTION	QTY.	REV.
	0801211	<b>MAST ASSEMBLY - 15VPSP (PRIOR TO S/N 03620)</b>	Ref.	I
	0801313	<b>MAST ASSEMBLY - 15VPSP (S/N 03620 TO PRESENT)</b>	Ref.	A
1	0100011	Loctite #242 (Not Shown)	A/R	
2	0362735	Bar, Sheave Pin Support	4	
3	0362736	Bar, Sheave Pin Support	2	
4	0561341	Block, Chain Anchor	1	
5	0641406	Bolt 1/4"-20NC x 3/4"	33	
6	0641407	Bolt 1/4"-20NC x 7/8"	6	
7	0641410	Bolt 1/4"-20NC x 1 1/4"	8	
8	0641508	Bolt 5/16"-18NC x 1"	1	
9	0641510	Bolt 5/16"-18NC x 1 1/4"	4	
10	0641812	Bolt 1/2"-13NC x 1 1/2"	4	
11	0741006	Screw #10-24NC x 3/4"	2	
12	0741606	Screw 3/8"-16NC x 3/4"	4	
13	0902047	Bracket, Sequence Cable	1	
14	0902422	Bracket, Bottom Chain Attach	1	
15	0902423	Bracket, Bottom Chain Attach	1	
16	0902424	Bracket, Bottom Chain Attach	1	
17	0902431	Bracket, Sequence Cable	3	
18	0902445	Bracket, Sequence Cable	2	
19	1060683	Cable, Sequence	3	
20 to 21	Not Used			
22	1271392	Channel, Mast #6	1	
23	1271419	Channel, Mast #3	1	
24	1271421	Channel, Mast #2	1	
25	1271455	Channel, Mast #1	1	
26	1271471	Channel, Mast Header	1	
27		Lift Cylinder Assembly Options (See Section 5 for Break-down):	1	
	1683808	Prior to S/N 03620		
	1684142	S/N 03620 to Present		
28	2880310	Key	3	
29	3311401	Nut 1/4"-20NC	6	
30	3311601	Nut 3/8"-16 NC	8	
31	3311801	Nut 1/2"-13NC	4	
32	3340845	Pad, Slide Guide	14	
33	3340858	Pad, Slide Guide	2	
34	3422338	Pin, Chain Equalizer	6	
35	3422717	Pin, Sheave	3	
36	3422750	Pin, Chain Equalizer	2	
37	3422752	Pin, Chain Equalizer	1	
38	3422757	Pin, Keeper	2	
39	3450304	Pin, Cotter	6	
40	3570893	Plate, Cylinder Mount	2	
41 to 42	Not Used			
43	3571788	Plate, Acuator Support	1	
44	3571790	Plate, Acuator Support	1	

**SECTION 3 MAST**

# SECTION 3 MAST

**FIGURE 3-1. MAST ASSEMBLY - 15VPSP (CONTINUED)**

FIG & ITEM #	PART NUMBER	DESCRIPTION	QTY.	REV.
45	3580268	Sheave Assembly (Prior to S/N 03620)	2	
	0440225	Bearing	1	
	3580267	Sheave, Chain	1	
	3580286	Sheave Assembly (S/N 03620 to Present)	2	
	0440246	Bearing	1	
	3580285	Sheave, Chain	1	
46	3580269	Sheave, Sequence Cable	3	
47	3580274	Sheave Assembly (Prior to S/N 03608)	4	
	0440230	Bearing	1	
	3580275	Sheave, Chain	1	
	3580249	Sheave Assembly (S/N 03608 to Present)	4	
	0440294	Bearing	1	
	3580275	Sheave, Chain	1	
48	3820034	Rivet	12	
49	3900187	Screw, Shoulder	3	
50	3900192	Screw, 3/8"-16NC x 1/2"	8	
51	3900205	Bolt #10-24NC x 5/8"	8	
52	4060960	Shield, Mast Cover	2	
53	4060961	Shield, Mast Cover	1	
54	4070860	Shim, Slide Pad	20	
55	4070861	Shim, Slide Pad	20	
56	4070862	Shim, Slide Pad	16	
57	4070970	Shim, Cylinder Mount	2	
58	4070971	Shim, Cylinder Mount	4	
59	4160124	Spring	3	
60	4567489	Tube, Spacer	2	
61	4567492	Tube, Spacer	1	
62	4567750	Tube, Spacer	1	
63	4711400	Flatwasher 1/4"	59	
64	4711500	Flatwasher 5/16"	3	
65	4711800	Flatwasher 1/2"	4	
66	4712600	Flatwasher 1" (Prior to S/N 03608)	16	
67	4740414	Washer, Cup	6	
68	4750800	Flatwasher #8 Wide	8	
69	4751500	Flatwasher 5/16" Wide	4	
70	4761000	Lockwasher #10	8	
71	4761400	Lockwasher 1/4"	3	
72	4761500	Lockwasher 5/16"	1	
73		Mount, Cylinder Options:	1	
	4845731	Prior to S/N 03620		
	4846381	S/N 03620 to Present		
74	0641408	Bolt 1/4"-20NC x 1"	3	
75	4061006	Shied	1	
76	3760383	Ring, Retainer	1	
77 to 82	Not Used			
83	1260355	Chain Assembly - #544 (See Items 101-107 for Breakdown)	1	
84	1260356	Chain Assembly - #444 (See Items 201-207 for Breakdown)	1	
85	1260357	Chain Assembly - #444 (See Items 301-307 for Breakdown)	1	
86	0902698	Bracket, Sequence Cable	1	

**SECTION 3 MAST**

# SECTION 3 MAST

**FIGURE 3-1. MAST ASSEMBLY - 15VPSP (CONTINUED)**

FIG & ITEM #	PART NUMBER	DESCRIPTION	QTY.	REV.
87	4070988	Shim, Slide Pad (S/N 03617 to Present)	2	
88	4070989	Shim, Slide Pad (S/N 03617 to Present)	2	
89	4070990	Shim, Slide Pad (S/N 03617 to Present)	2	
90	4567749	Tube, Spacer (S/N 03617 to Present)	1	
91	4567751	Tube, Spacer (S/N 03617 to Present)	1	
92	4740007	Washer, Thrust (S/N 03617 to Present)	14	
	Not Available	Mast Kit (Not Available at Time of Printing)	1	
	1260355	<b>CHAIN ASSEMBLY - #544 CHAIN</b>	Rev.	C
101	0100062	Loctite #RC/640 (Not Shown)	A/R	
102	0561308	Block, Chain Anchor	2	
103	0561336	Block, Chain Anchor	2	
104	Use 1260355	Chain	11.8ft/3.6m	
105	3422338	Pin, Groove	2	
106	3422720	Pin, Groove	4	
107	3450202	Pin, Cotter	8	
108	3450304	Pin, Cotter	2	
109	3571101	Plate, Chain Adjustment	1	
110	4300129	Stud	2	
111	4751500	Flatwasher 5/16"	2	
	1260356	<b>CHAIN ASSEMBLY - #444 CHAIN</b>	Rev.	C
201	0100062	Loctite #RC/640 (Not Shown)	A/R	
202	0561149	Block, Chain Anchor	2	
203	0561408	Block, Chain Anchor	2	
204	Use 1260356	Chain	11.8ft/3.6m	
205	3422338	Pin, Groove	2	
206	3422346	Pin, Groove	2	
207	3422355	Pin, Groove	2	
208	3450304	Pin, Cotter	2	
209	3571103	Plate, Chain Adjustment	1	
210	4300111	Stud	2	
211	4751500	Flatwasher 5/16"	2	
	1260357	<b>CHAIN ASSEMBLY - #444 CHAIN</b>	Rev.	C
301	0100062	Loctite #RC/640 (Not Shown)	A/R	
302	0561149	Block, Chain Anchor	2	
303	0561408	Block, Chain Anchor	2	
304	Use 1260357	Chain	11.8ft/3.6m	
305	3422338	Pin, Groove	2	
306	3422346	Pin, Groove	2	
307	3422355	Pin, Groove	2	
308	3450304	Pin, Cotter	2	
309	3571101	Plate, Chain Adjustment	1	
310	4300111	Stud	2	

SECTION 3 MAST

# SECTION 3 MAST

FIGURE 3-1. MAST ASSEMBLY - 15VPSP (CONTINUED)

FIG & ITEM #	PART NUMBER	DESCRIPTION	QTY.	REV.
311	4751500	Flatwasher 5/16"	2	

**S  
E  
C  
T  
I  
O  
N  
  
3  
  
M  
A  
S  
T**



# SECTION 3 MAST

FIGURE 3-1. MAST ASSEMBLY - 15VPSP (CONTINUED)

FIG & ITEM #	PART NUMBER	DESCRIPTION	QTY.	REV.

**S  
E  
C  
T  
I  
O  
N  
  
3  
  
M  
A  
S  
T**

# SECTION 3 MAST

FIGURE 3-2. MAST MOUNTING COMPONENTS

SECTION 3 MAST

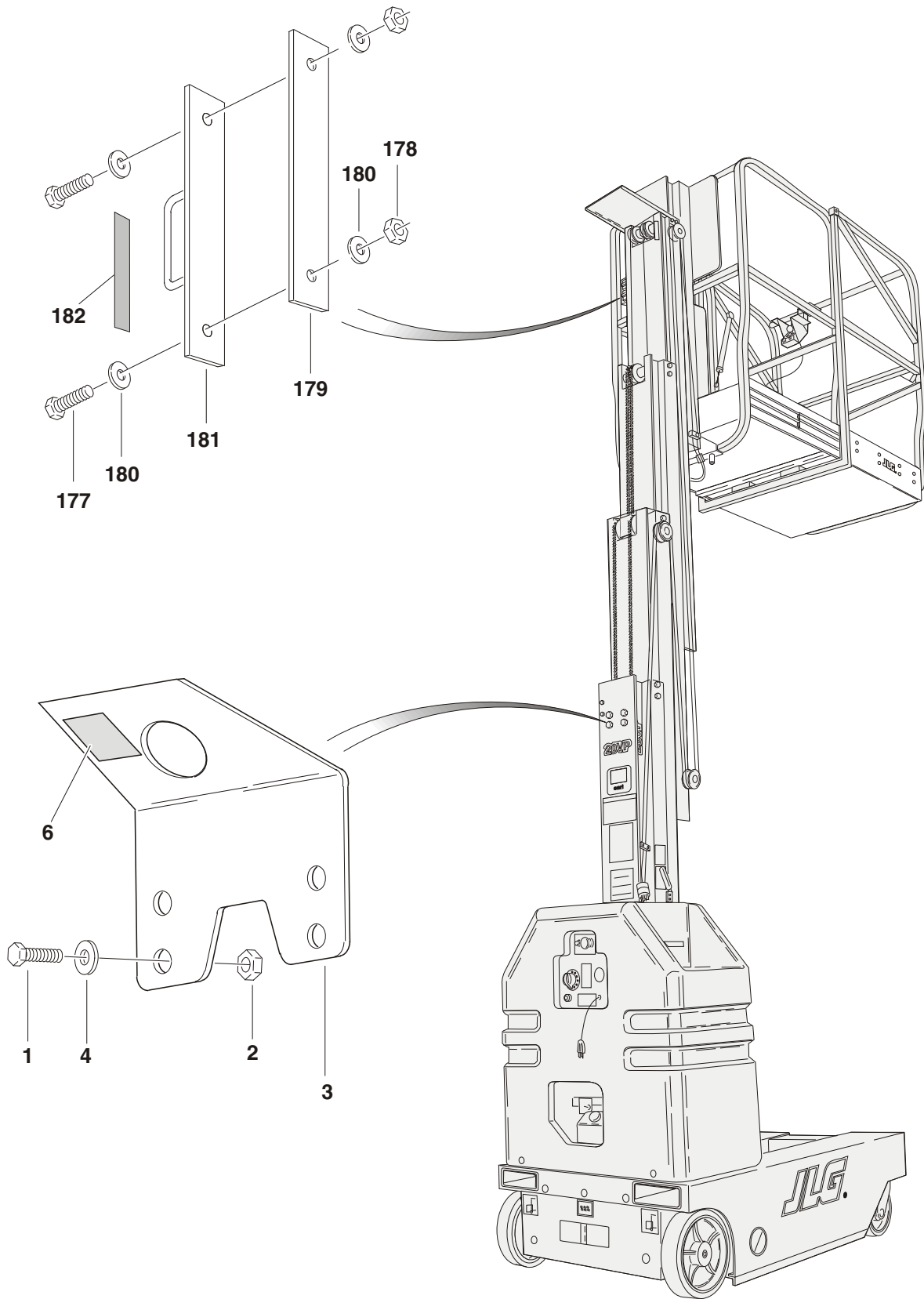

# SECTION 3 MAST

**FIGURE 3-2. MAST MOUNTING COMPONENTS**

FIG & ITEM #	PART NUMBER	DESCRIPTION	QTY.	REV.
	0258448	<b>OPTIONAL CRANE HOOK INSTALLATION</b>	Ref.	C
1	0641612	Bolt 3/8"-16NC x 1 1/2"	4	
2	3311605	Locknut 3/8"-16NC	4	
3	3570976	Plate, Crane Hook	1	
4	4711600	Flatwasher 3/8"	8	
5	Not Used			
6	1703455	Decal - Crane Hook	1	
	0801211	<b>MAST ASSEMBLY - 15VPSP (SAFETY ATTACH)</b>	Ref.	I
101 to 176	Not Used			
177	0641812	Bolt 1/2"-13NC x 1 1/2"	2	
178	3271805	Locknut 1/2"-13NC	2	
179	3539814	Plate, Safety Attach Backing	1	
180	4751800	Flatwasher 1/2" Wide	4	
181	4845345	Weldment, Safety Attach	1	
182	1704277	Decal - Lanyard Attach	1	

SECTION 3 MAST

# SECTION 3 MAST

FIGURE 3-2. MAST MOUNTING COMPONENTS (CONTINUED)

FIG & ITEM #	PART NUMBER	DESCRIPTION	QTY.	REV.

**S  
E  
C  
T  
I  
O  
N  
  
3  
  
M  
A  
S  
T**

# SECTION 4 PLATFORM

## TABLE OF CONTENTS

FIGURE	DESCRIPTION	PAGE
4-1	PLATFORM INSTALLATION (FOLD-DOWN SIDE RAILS) . . . . .	4-2
4-2	PLATFORM INSTALLATION (FIXED SIDE RAILS) . . . . .	4-6
4-3	PLATFORM INSTALLATION (QUICK CHANGE GULLWING) . . . . .	4-10
4-4	PLATFORM INSTALLATION (QUICK CHANGE MOLDED) . . . . .	4-14

# SECTION 4 PLATFORM

# SECTION 4 PLATFORM

FIGURE 4-1.PLATFORM INSTALLATION (FOLD DOWN SIDE RAILS)

SECTION 4 PLATFORM

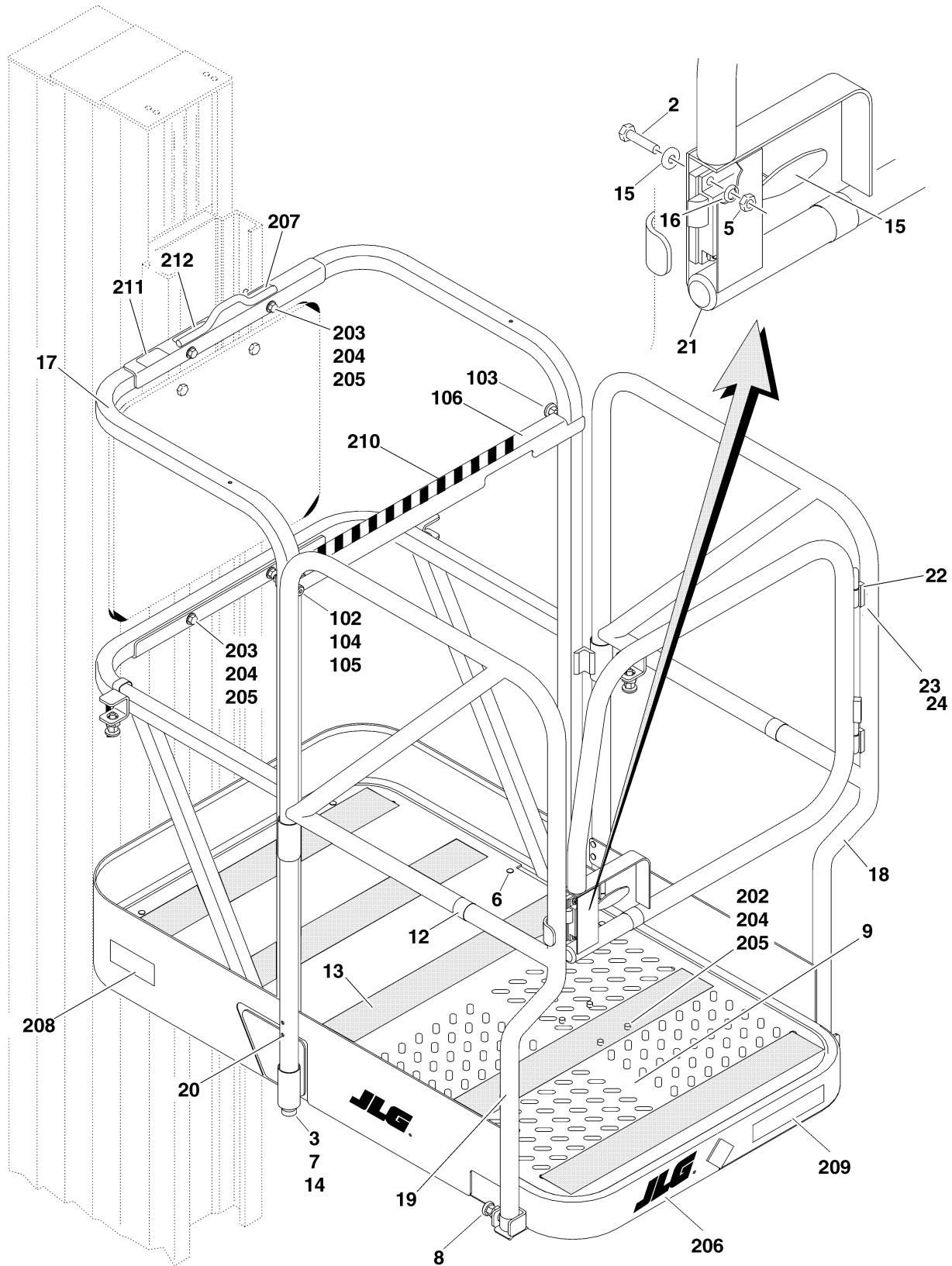

# SECTION 4 PLATFORM

**FIGURE 4-1. PLATFORM INSTALLATION (FOLD DOWN SIDE RAILS)**

FIG & ITEM #	PART NUMBER	DESCRIPTION	QTY.	REV.
	0259350	<b>PLATFORM ASSEMBLY</b>	Ref.	G
1	0100011	Loctite #242 (Not Shown)	A/R	
2	0721008	Screw	4	
3	0940049	Stopper, Hood	2	
4	2940074	Latch	1	
5	3311001	Nut #10-24NC	4	
6	3820032	Rivet	12	
7	3311501	Nut 5/16"-18NC	4	
8	3422744	Pin, Plunger	5	
9	3571552	Plate, Platform Pan	1	
10 to 11	Not Required			
12	4280296	Strip, Wear	2ft/0.6m	
13	4420039	Tape, Non Skid	10ft/3.0m	
14	4751500	Flatwasher 5/16" Wide	4	
15	4751000	Flatwasher #10 Wide	4	
16	4761000	Lockwasher #10	4	
17		Platform Options:	1	
	4846030	Prior to S/N 03571		
	4846323	S/N 03571 to S/N 03620		
	4846521	S/N 03620 to Present		
18		Platform, Gate Options:	1	
	4846034	Prior to S/N 03571		
	4846324	S/N 03571 to Present		
19		Rail, Platform Gate Options:	1	
	4846035	Prior to S/N 03571		
	4846325	S/N 03571 to Present		
20	2080040	Fastener, Huck	4	
21	3520176	Plug	1	
22	0962337	Bushing, Hinge (S/N 03479 to Present)	2	
23	3422866	Pin, Hinge (S/N 03479 to Present)	2	
24	3760448	Ring, Snap (S/N 03479 to Present)	2	
	0270065	<b>PLATFORM SUB ASSEMBLY</b>	Ref.	A
101	Not Required			
102	3311605	Locknut 3/8"-16NC	1	
103	3422744	Pin, Plunger	1	
104	3900270	Bolt, Shoulder 1/2"-16NC x 1/2"	1	
105	4711600	Flatwasher 3/8" Narrow	1	
106	4846129	Rail, Top	1	
	0271407	<b>PLATFORM INSTALLATION</b>	Ref.	A
201	Not Required			
202	0641616	Bolt 3/8"-16NC x 2"	2	
203	0641620	Bolt 3/8"-16NC x 2 1/2"	4	
204	3311605	Locknut 3/8"-16NC	6	

SECTION 4 PLATFORM

# SECTION 4 PLATFORM

FIGURE 4-1. PLATFORM INSTALLATION (FOLD DOWN SIDE RAILS) (CONTINUED)

FIG & ITEM #	PART NUMBER	DESCRIPTION	QTY.	REV.
205	4711600	Flatwasher 3/8"	12	
206	1703681	Decal - JLG	5	
207	1704277	Decal - Lanyard Attach	1	
208	1704458	Decal - JLG Manufacturing	1	
209	1704467	Decal - Model Designation	1	
210	1704469	Decal - Close Gate	1	
211	1704980	Decal - Fall Hazard	1	
212	1704981	Decal - 120V AC	1	

**S  
E  
C  
T  
I  
O  
N  
  
4  
  
P  
L  
A  
T  
F  
O  
R  
M**



# SECTION 4 PLATFORM

FIGURE 4-1. PLATFORM INSTALLATION (FOLD DOWN SIDE RAILS) (CONTINUED)

FIG & ITEM #	PART NUMBER	DESCRIPTION	QTY.	REV.

**S  
E  
C  
T  
I  
O  
N  
  
4  
  
P  
L  
A  
T  
F  
O  
R  
M**

# SECTION 4 PLATFORM

## FIGURE 4-2.PLATFORM INSTALLATION (FIXED SIDE RAILS)

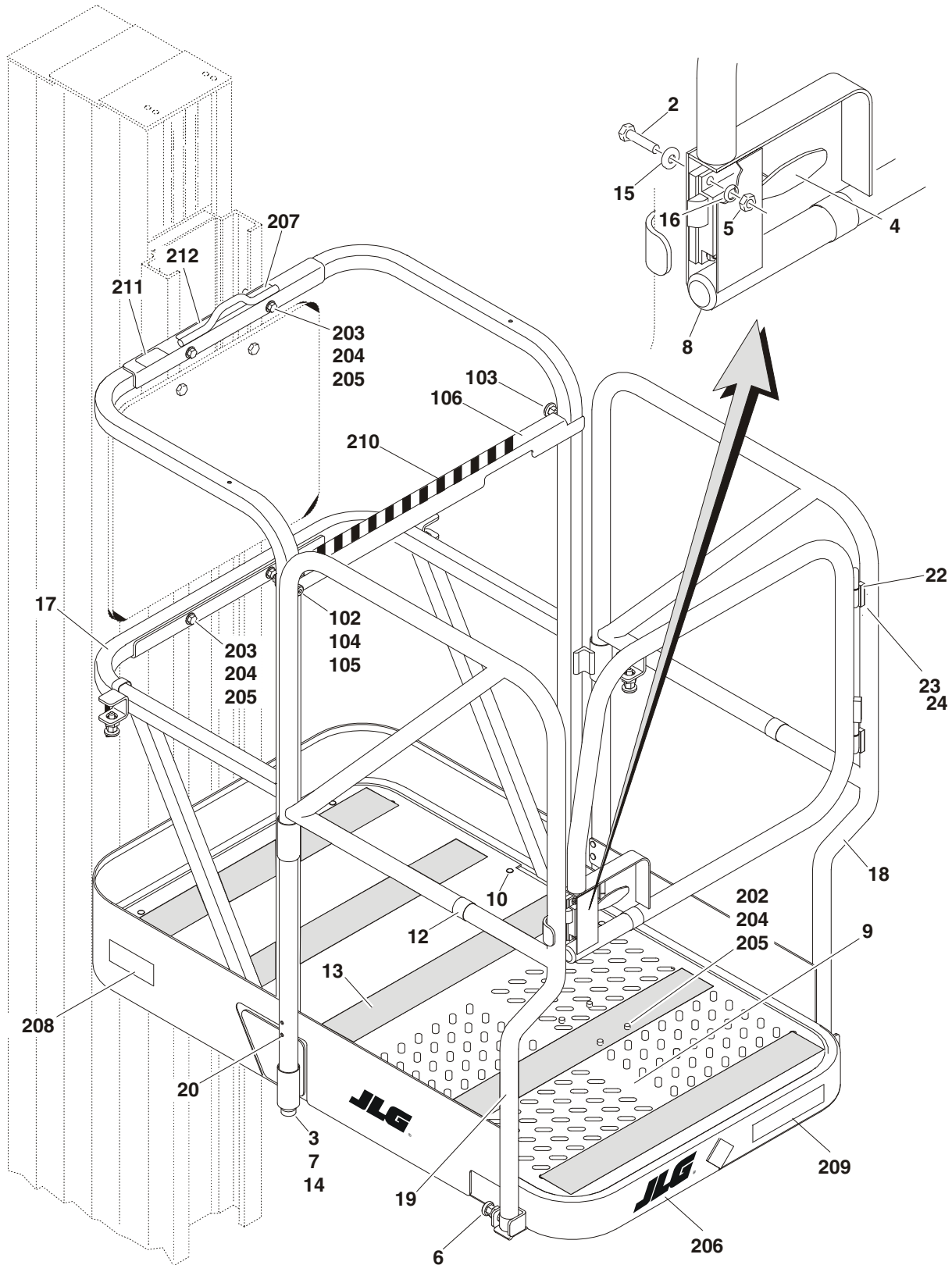

SECTION 4 PLATFORM

# SECTION 4 PLATFORM

**FIGURE 4-2. PLATFORM INSTALLATION (FIXED SIDE RAILS)**

FIG & ITEM #	PART NUMBER	DESCRIPTION	QTY.	REV.
	0270438	<b>PLATFORM ASSEMBLY</b>	Ref.	C
1	0100011	Loctite #242 (Not Shown)	A/R	
2	0721008	Screw	4	
3	0940049	Stopper, Hood	2	
4	2940074	Latch	1	
5	3311001	Nut #10-24NC	4	
6	0630545	Bolt 5/8"-18NC	2	
7	3311501	Nut 5/16"-18NC	4	
8	3520176	Plug	1	
9	3571552	Plate, Platform Pan	1	
10	3820032	Rivet	12	
11	Not Required			
12	4280296	Strip, Wear	20in/51cm	
13	4420039	Tape, Non Skid	10ft/6.1m	
14	4751500	Flatwasher 5/16" Wide	4	
15	4751000	Flatwasher #10 Wide	4	
16	4761000	Lockwasher #10	4	
17	4846323	Platform	1	
18	4846324	Platform, Gate	1	
19	4846325	Rail, Platform Gate	1	
20	2080040	Fastener, Huck	4	
22	0962337	Bushing, Hinge	2	
23	3422866	Pin, Hinge	2	
24	3760448	Ring, Snap	2	
	0270440	<b>PLATFORM SUB ASSEMBLY</b>	Ref.	A
101	Not Required			
102	3311605	Locknut 3/8"-16NC	1	
103	3422744	Pin, Plunger	1	
104	3900270	Bolt, Shoulder 1/2"-16NC x 1/2"	1	
105	4711600	Flatwasher 3/8" Narrow	1	
106	4846129	Rail, Top	1	
	0271408	<b>PLATFORM INSTALLATION</b>	Ref.	A
201	Not Required			
202	0641616	Bolt 3/8"-16NC x 2"	2	
203	0641620	Bolt 3/8"-16NC x 2 1/2"	4	
204	3311605	Locknut 3/8"-16NC	6	
205	4711600	Flatwasher 3/8"	12	
206	1703681	Decal - JLG	5	
207	1704277	Decal - Lanyard Attach	1	
208	1704458	Decal - JLG Manufacturing	2	
209	1704467	Decal - Model Designation	1	
210	1704469	Decal - Close Gate	1	
211	1704980	Decal - Fall Hazard	1	

SECTION 4 PLATFORM

# SECTION 4 PLATFORM

FIGURE 4-2. PLATFORM INSTALLATION (FIXED SIDE RAILS) (CONTINUED)

FIG & ITEM #	PART NUMBER	DESCRIPTION	QTY.	REV.
212	1704981	Decal - 120V AC	1	

**S  
E  
C  
T  
I  
O  
N  
  
4  
  
P  
L  
A  
T  
F  
O  
R  
M**

# SECTION 4 PLATFORM

FIGURE 4-2. PLATFORM INSTALLATION (FIXED SIDE RAILS) (CONTINUED)

FIG & ITEM #	PART NUMBER	DESCRIPTION	QTY.	REV.

**S  
E  
C  
T  
I  
O  
N  
4  
P  
L  
A  
T  
F  
O  
R  
M**

# SECTION 4 PLATFORM

FIGURE 4-3.PLATFORM INSTALLATION (QUICK CHANGE GULLWING)

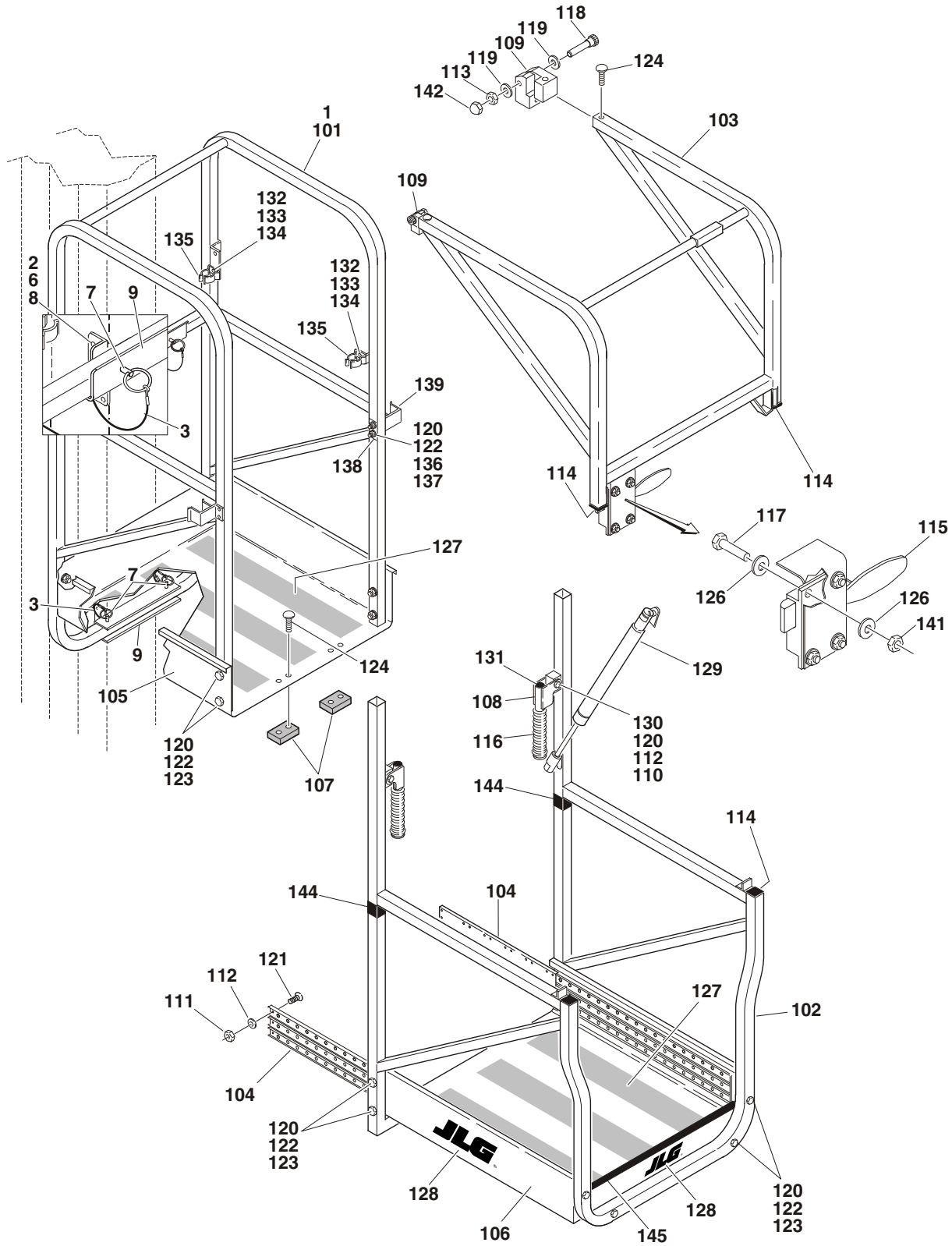

SECTION 4 PLATFORM

# SECTION 4 PLATFORM

**FIGURE 4-3. PLATFORM INSTALLATION (QUICK CHANGE GULLWING)**

FIG & ITEM #	PART NUMBER	DESCRIPTION	QTY.	REV.
	0270513	<b>PLATFORM INSTALLATION</b>	Ref.	A
1	Not Required			
2	0641408	Bolt 1/4"-20NC x 1"	8	
3	1060380	Cable, Lanyard	4	
4 to 5	Not Used			
6	3311405	Locknut 1/4"-20NC	8	
7	3422657	Pin, Quick Release	4	
8	4711400	Flatwasher 1/4" Narrow	16	
9	4846921	Bracket	2	
	0258586	<b>PLATFORM ASSEMBLY</b>	Ref.	5
101	4845810	Weldment, Platform Rail (Stationary)	1	
102	4845811	Weldment, Platform Rail (Extension)	1	
103	4845812	Weldment, Gate	1	
104	2020005	Glides, Extension	1 Pair	
105	3570362	Pan, Floor (Stationary)	1	
106	3570274	Pan, Floor (Extension)	1	
107	3340829	Pad, Slide	2	
108	4845614	Handle	2	
109	2600225	Hinge, Gate	4	
110	3900200	Bolt, Shoulder	2	
111	3311005	Locknut #10-24NC	64	
112	4751000	Flatwasher #10	66	
113	3311505	Locknut 5/16"-18NC	2	
114	3520072	Cap-Plug	4	
115	2940074	Latch	1	
116	2560154	Grip, Handle	2	
117	0721006	Bolt #10-24NC x 3/4"	4	
118	3900032	Bolt, Shoulder	2	
119	4711600	Flatwasher 3/8" (Narrow)	4	
120	3311405	Locknut 1/4"-20NC	22	
121	3900252	Screw, Button Head 1/4"-20NC	64	
122	4711400	Flatwasher 1/4" (Narrow)	40	
123	0641414	Bolt 1/4"-20NC x 1 3/4"	16	
124	3900258	Screw, Button Head 1/4"-20NC x 3/4"	8	
125	0100011	Loctite #242 (Not Shown)	A/R	
126	4751000	Flatwasher #10	8	
127	4420039	Tape, Non Skid	11ft/3.4m	
128	1703681	Decal - JLG	3	
129	4160165	Spring, Gas Shock (Note: Not Include Brackets)	1	
	0902877	Bracket, Mounting	2	
130	4711500	Flatwasher 5/16" (Narrow)	4	
131	3250030	Plug, Hole	2	
132	0720805	Screw #8-32NC x 5/8"	4	
133	4750800	Flatwasher #8	8	
134	3310805	Locknut #8-32NC	4	

# SECTION 4 PLATFORM

**FIGURE 4-3. PLATFORM INSTALLATION (QUICK CHANGE GULLWING) (CONTINUED)**

FIG & ITEM #	PART NUMBER	DESCRIPTION	QTY.	REV.
135	1380132	Clip, Gripper	4	
136	0641416	Bolt 1/4"-20NC x 2"	4	
137	3570653	Plate, Shim	2	
138	3570654	Plate, Backing	2	
139	4845657	Weldment, Stop	2	
140	Not Used			
141	3311005	Locknut #10-24NC	4	
142	3300356	Nut, Acorn 5/16"-18NC	2	
143	Not Used			
144	4280296	Strip, Wear	10in/25cm	
145	4060803	Shield, Flex-Trim	2.2ft/0.67m	

**SECTION 4 PLATFORM**



# SECTION 4 PLATFORM

FIGURE 4-3. PLATFORM INSTALLATION (QUICK CHANGE GULLWING) (CONTINUED)

FIG & ITEM #	PART NUMBER	DESCRIPTION	QTY.	REV.

**S  
E  
C  
T  
I  
O  
N  
  
4  
  
P  
L  
A  
T  
F  
O  
R  
M**

# SECTION 4 PLATFORM

FIGURE 4-4.PLATFORM INSTALLATION (QUICK CHANGE MOLDED)

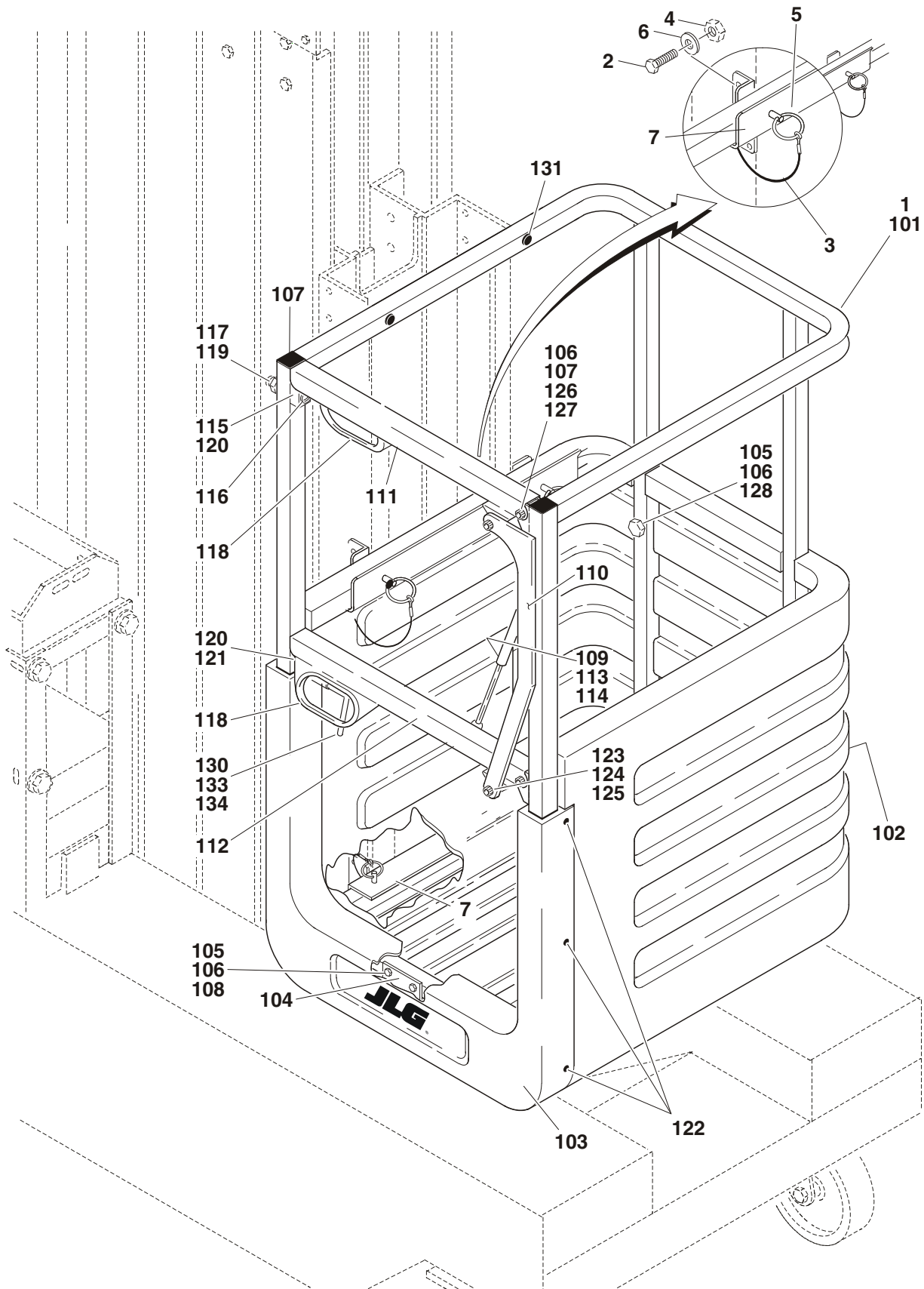

SECTION 4 PLATFORM

# SECTION 4 PLATFORM

**FIGURE 4-4. PLATFORM INSTALLATION (QUICK CHANGE MOLDED)**

FIG & ITEM #	PART NUMBER	DESCRIPTION	QTY.	REV.
	0270512	<b>MOLDED PLATFORM INSTALLATION</b>	Ref.	A
1	Not Used			
2	0641408	Bolt 1/4"-20NC x 1"	8	
3	1060380	Cable, Lanyard	4	
4	3311405	Locknut 1/4"-20NC	8	
5	3422657	Pin, Ball Detent	4	
6	4711400	Flatwasher 1/4"	16	
7	4846021	Weldment, Platform Mount	2	
	0258672	<b>PLATFORM ASSEMBLY</b>	Ref.	1/A
101	4845822	Rail	1	
102	3510676	Basket	1	
103	4060882	Cover	1	
104	4845831	Weldment, Bottom Mount	1	
105	0641416	Bolt 1/4"-20NC x 2"	10	
106	4751400	Flatwasher 1/4"	22	
107	3520072	Cap	4	
108	3311405	Locknut 1/4"-20NC	12	
109	4160125	Spring, Gas	1	
110	0362347	Link, Gate	1	
111	3640924	Rail, Gate (Top)	1	
112	3640990	Rail, Gate (Bottom)	1	
113	4751500	Flatwasher 5/16"	1	
114	3311505	Locknut 5/16"-18NC	1	
115	3340746	Pad, Gate Rest	1	
116	3911032	Screw, Machine #10-24NC x 2"	4	
117	4751000	Flatwasher #10	8	
118	4060803	Flex-Trim	2ft/0.6m	
119	3311001	Nut #10-24NC	4	
120	4070890	Shim, Gate Stop	2	
121	3340754	Pad, Gate Latch	1	
122	3900177	Screw, Plastiite	6	
123	3900202	Bolt, Shoulder	2	
124	4740429	Washer, Nylon	4	
125	3311005	Locknut #10-24NC	2	
126	3900203	Bolt, Shoulder	2	
127	4740428	Washer, Nylon	4	
128	3300151	Nut, Acorn 1/4"-20NC	2	
129	0100011	Loctite #242 (Not Shown)	A/R	
130	2940082	Latch, Gate	1	
131	3520028	Plug	4	
132	Not Used			
133	3820024	Rivet	2	
134	4070894	Shim, Gate Latch	1	

SECTION 4 PLATFORM

# SECTION 4 PLATFORM

FIGURE 4-4. PLATFORM INSTALLATION (QUICK CHANGE MOLDED) (CONTINUED)

FIG & ITEM #	PART NUMBER	DESCRIPTION	QTY.	REV.

**S  
E  
C  
T  
I  
O  
N  
  
4  
  
P  
L  
A  
T  
F  
O  
R  
M**

# SECTION 5 CYLINDER

TABLE OF CONTENTS		
FIGURE	DESCRIPTION	PAGE
5-1	LIFT CYLINDER ASSEMBLY .....	5-2

**S  
E  
C  
T  
I  
O  
N  
  
5  
  
C  
Y  
L  
I  
N  
D  
E  
R**

# SECTION 5 CYLINDER

## FIGURE 5-1. LIFT CYLINDER ASSEMBLY

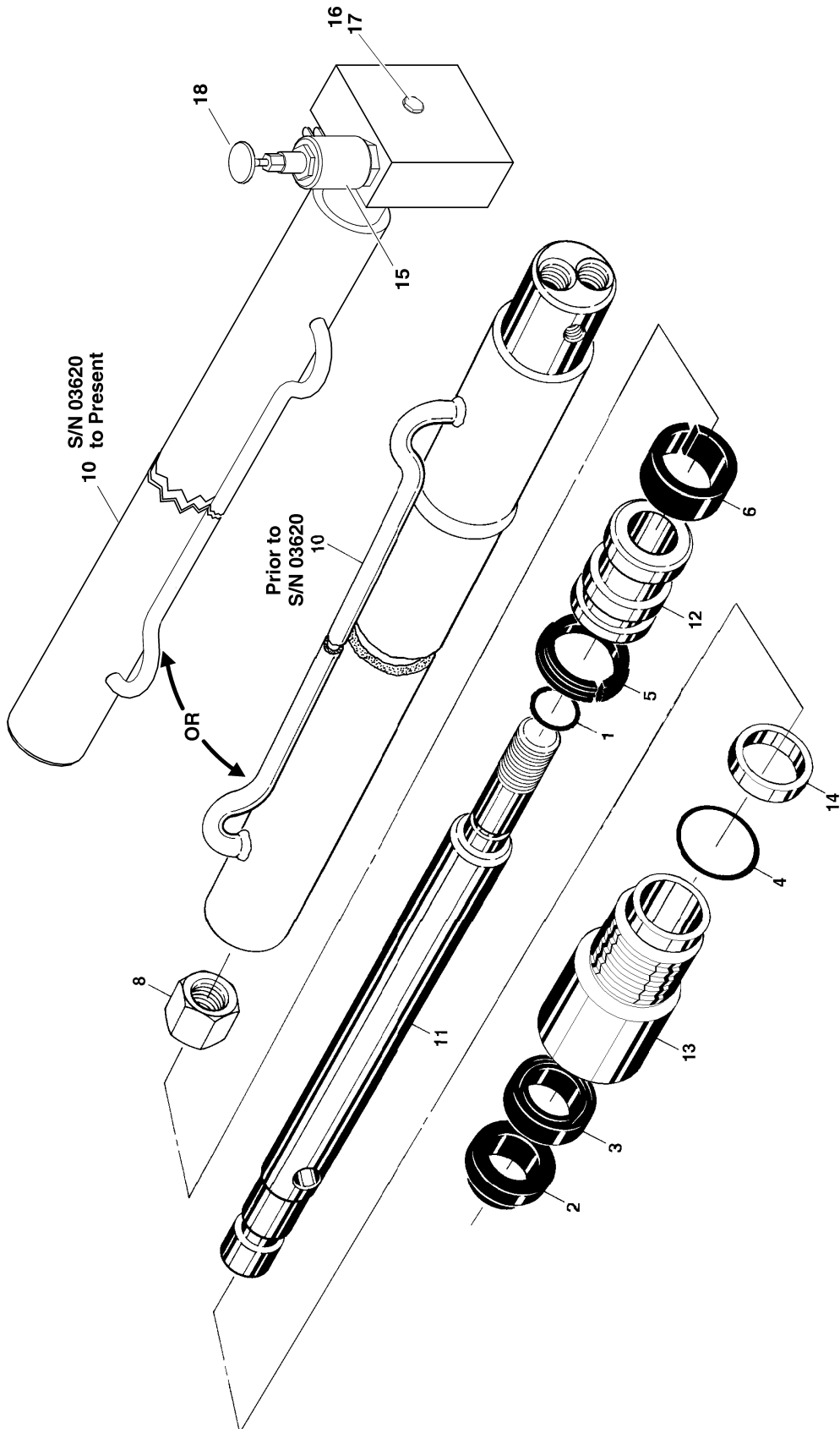

SECTION 5 CYLINDER

# SECTION 5 CYLINDER

**FIGURE 5-1. LIFT CYLINDER ASSEMBLY**

FIG & ITEM #	PART NUMBER	DESCRIPTION	QTY.	REV.
		<b>LIFT CYLINDER ASSEMBLIES</b>	Ref.	
	1683808	<b>PRIOR TO S/N 03620</b>	Ref.	A
	1684142	<b>S/N 03620 TO PRESENT</b>	Ref.	G
1	Kit	O-Ring	1	
2	Kit	Wiper	1	
3	Kit	Seal	1	
4	Kit	O-Ring	1	
5	Kit	Seal	1	
6	Kit	Ring, Wear	1	
7	Not Used			
8		Locknut Options:	1	
	7003246	Prior to S/N 03620		
	7023391	S/N 03620 to Present		
9	Not Used			
10		Barrel Options:	1	
	7019839	Prior to S/N 03620		
	Not Available	S/N 03620 to Present		
11		Rod Options:	1	
	7019838	Prior to S/N 03620		
	7023393	S/N 03620 to Present		
12		Piston Options:	1	
	7019835	Prior to S/N 03620		
	7023392	S/N 03620 to Present		
13		Head Options:	1	
	7019834	Prior to S/N 03620		
	7023394	S/N 03620 to Present		
14		Spacer Options:	1	
	7019872	Prior to S/N 03620		
	Not Required	S/N 03620 to Present		
15		Poppet, Solenoid Valve (S/N 03620 to Present Only)	1	
	7024354	Poppet, Solenoid Valve - 20 Volt Coil		
	7012958	20 Volt Coil Only		
	7012998	Seal Kit		
16	7023397	Spring (S/N 03620 to Present Only)	1	
17	7023398	Control Valve (S/N 03620 to Present Only)	1	
18	7023399	Knob-Red	1	
		-----		
	7019865	Seal Kit - 1683808 (Includes Items 1-6)	1	
	7023395	Seal Kit - 1684142 (Includes Items 1-6)	1	

**SECTION 5 CYLINDER**

# SECTION 5 CYLINDER

FIGURE 5-1. LIFT CYLINDER ASSEMBLY (CONTINUED)

FIG & ITEM #	PART NUMBER	DESCRIPTION	QTY.	REV.

**S  
E  
C  
T  
I  
O  
N  
  
5  
  
C  
Y  
L  
I  
N  
D  
E  
R**



# SECTION 6 HYDRAULIC

TABLE OF CONTENTS		
FIGURE	DESCRIPTION	PAGE
6-1	HYDRAULIC DIAGRAM (PRIOR TO S/N 03620) .....	6-2
6-2	HYDRAULIC DIAGRAM (S/N 03620 TO PRESENT) .....	6-4

**S  
E  
C  
T  
I  
O  
N  
  
6  
  
H  
Y  
D  
R  
A  
U  
L  
I  
C**

# SECTION 6 HYDRAULIC

FIGURE 6-1.HYDRAULIC DIAGRAM

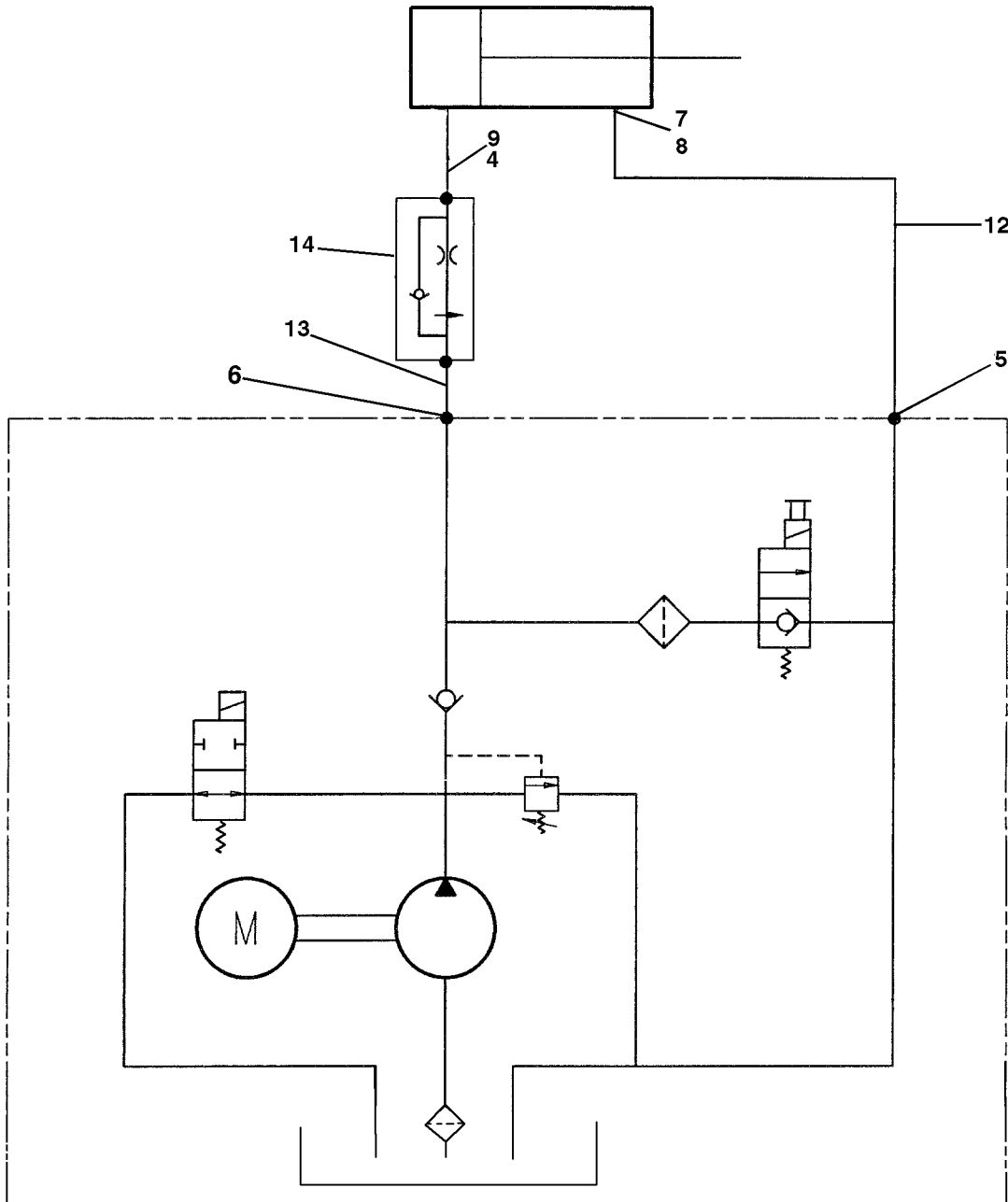

SECTION 6 HYDRAULIC

# SECTION 6 HYDRAULIC

**FIGURE 6-1. HYDRAULIC DIAGRAM**

FIG & ITEM #	PART NUMBER	DESCRIPTION	QTY.	REV.
	0259774 2792403	<b>HYDRAULIC DIAGRAM</b>	Ref.	A
1	0100020	Sealant, Pipe (Not Shown)	A/R	
2 to 3	Not Used			
4	2220416	Fitting	1	
5	2220472	Fitting	1	
6	2220473	Fitting	1	
7	2220507	Fitting, 90°	1	
8	2220603	Fitting	1	
9	2220875	Fitting	1	
10 to 11	Not Used			
12	4568026	Tube, Return	1	
13	4568027	Tube, Extension	1	
14	4640956	Valve, Flow	1	

**SECTION 6 HYDRAULIC**

# SECTION 6 HYDRAULIC

FIGURE 6-2. HYDRAULIC DIAGRAM (S/N 03620 TO PRESENT)

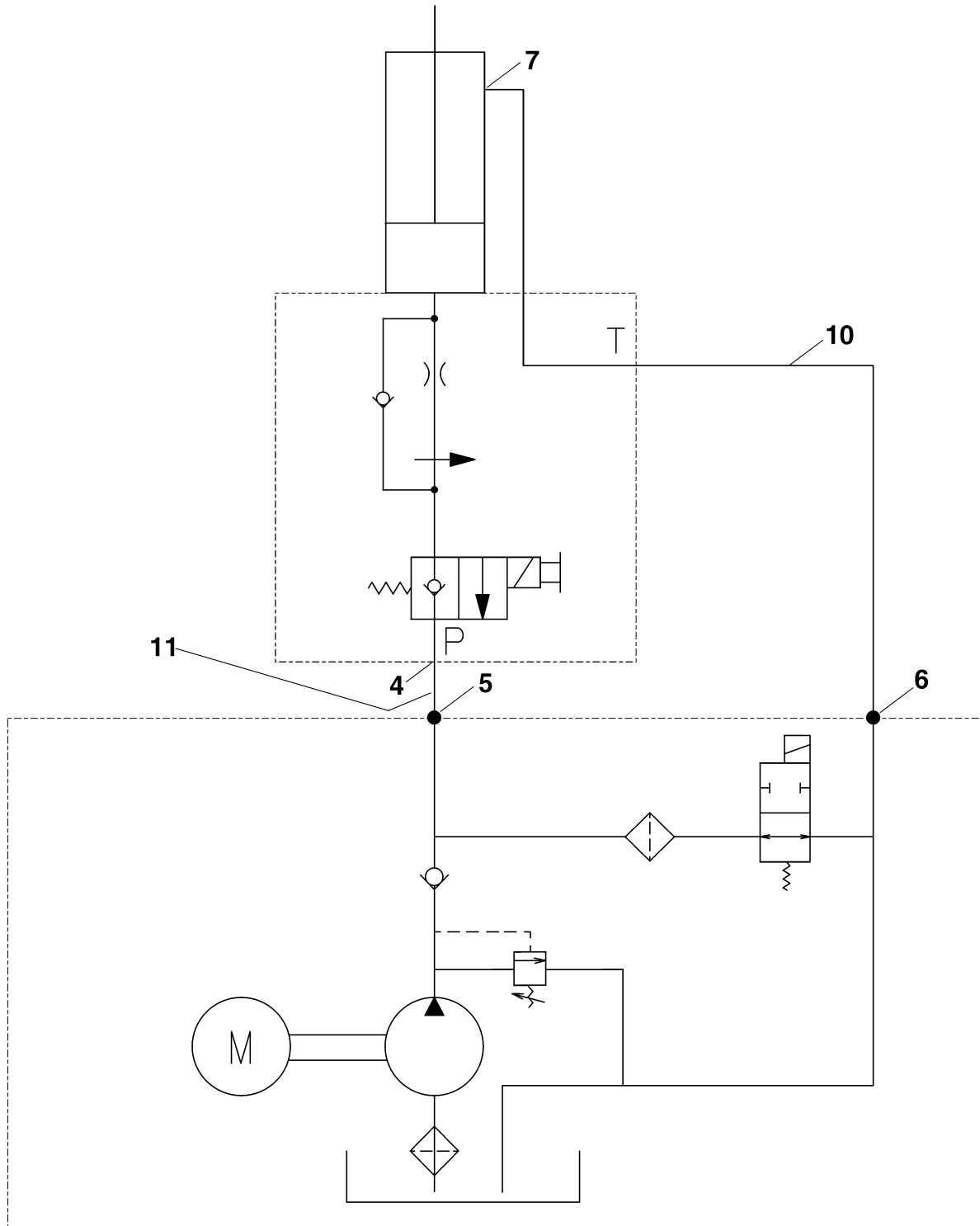

SECTION 6 HYDRAULIC

# SECTION 6 HYDRAULIC

**FIGURE 6-2. HYDRAULIC DIAGRAM (S/N 03620 TO PRESENT)**

FIG & ITEM #	PART NUMBER	DESCRIPTION	QTY.	REV.
	0271466 2792491	<b>HYDRAULIC DIAGRAM</b>	Ref.	A
1	0100020	Sealant, Pipe (Not Shown)	A/R	
2 to 3	Not Used			
4	2220415	Fitting	1	
5	2220472	Fitting	1	
6	2220473	Fitting	1	
7	2220603	Fitting	1	
8 to 9	Not Used			
10	4568285	Tube, Return	1	
11	4568286	Tube, Extension	1	

**SECTION 6 HYDRAULIC**

# SECTION 6 HYDRAULIC

FIGURE 6-2. HYDRAULIC DIAGRAM (S/N 03620 TO PRESENT) (CONTINUED)

FIG & ITEM #	PART NUMBER	DESCRIPTION	QTY.	REV.

**S  
E  
C  
T  
I  
O  
N  
  
6  
  
H  
Y  
D  
R  
A  
U  
L  
I  
C**

# SECTION 7 ELECTRICAL

## TABLE OF CONTENTS

FIGURE	DESCRIPTION	PAGE
7-1	ELECTRICAL SCHEMATIC (PRIOR TO S/N 03620 . . . . .	7-2
7-2	ELECTRICAL SCHEMATIC (S/N 03620 TO PRESENT) . . . . .	7-3
7-3	ELECTRICAL COMPONENTS INSTALLATION . . . . .	7-4

**S  
E  
C  
T  
I  
O  
N  
  
7  
  
E  
L  
E  
C  
T  
R  
I  
C  
A  
L**

# SECTION 7 ELECTRICAL

FIGURE 7-1.ELECTRICAL SCHEMATIC (PRIOR TO S/N 03620)

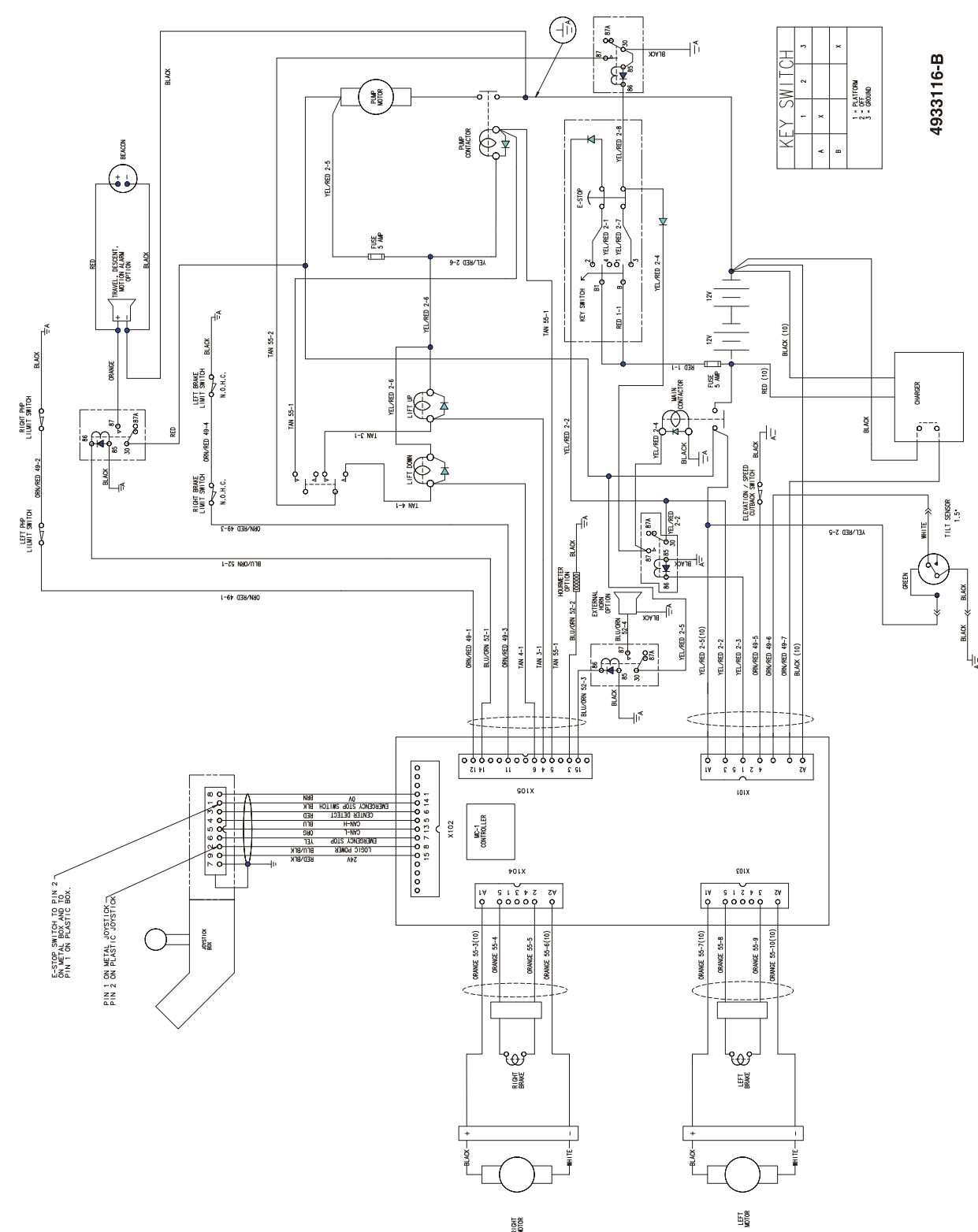

SECTION 7 ELECTRICAL



# SECTION 7 ELECTRICAL

FIGURE 7-2.ELECTRICAL SCHEMATIC (S/N 03620 TO PRESENT)

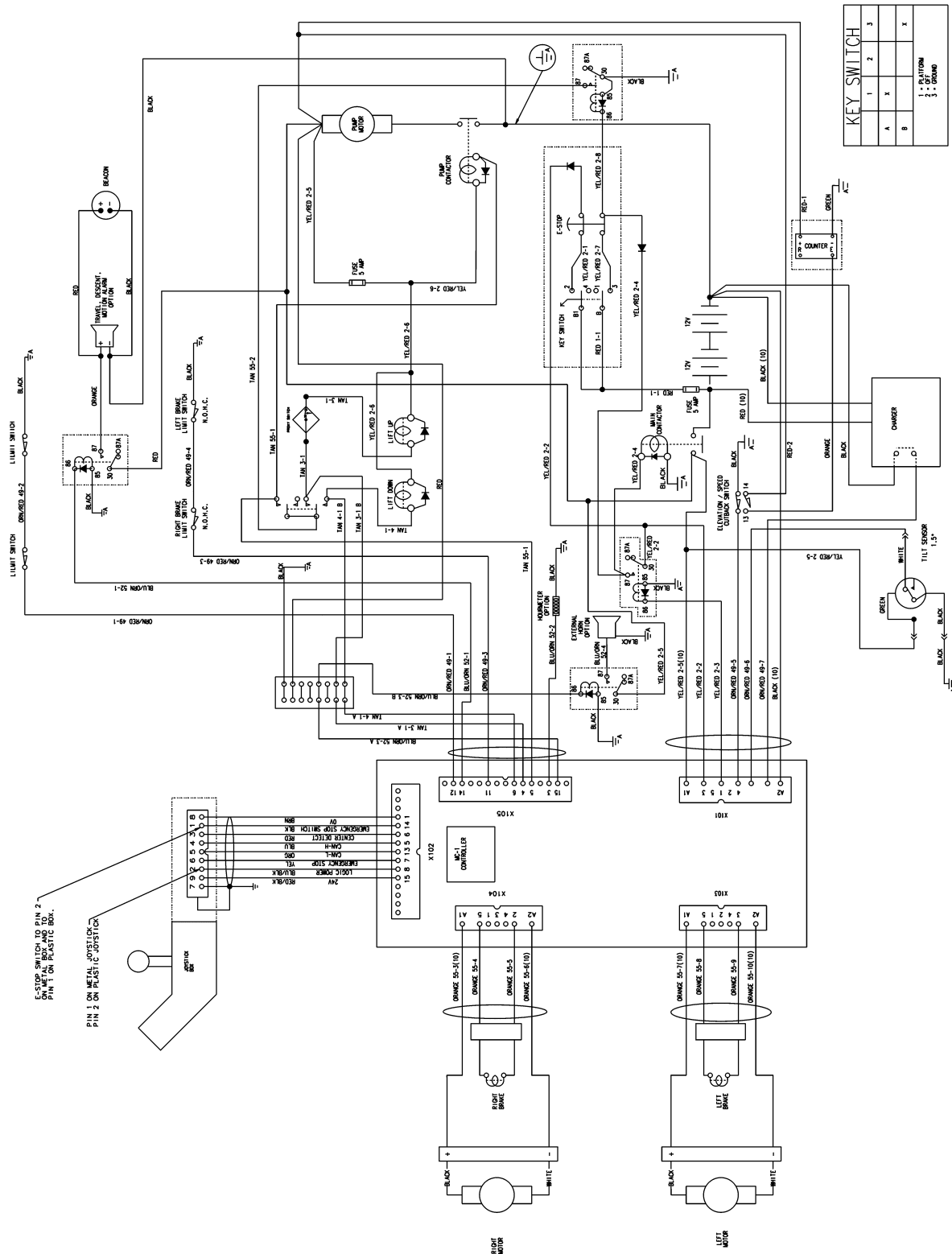

KEY SWITCH		
1	2	3
A	X	
B		X

4933172\_D

# SECTION 7 ELECTRICAL

FIGURE 7-3. ELECTRICAL COMPONENTS INSTALLATION

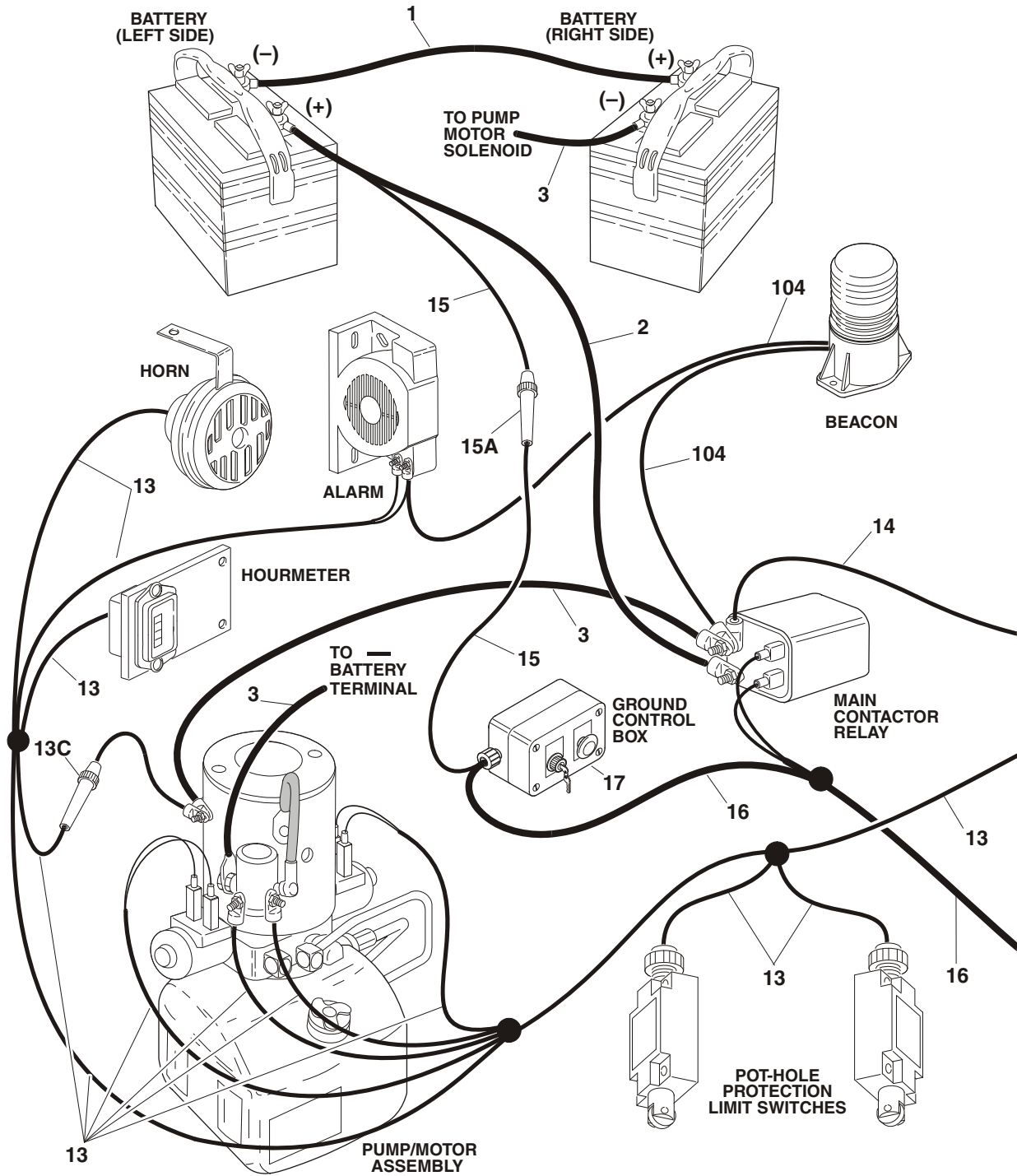

SECTION 7 ELECTRICAL

# SECTION 7 ELECTRICAL

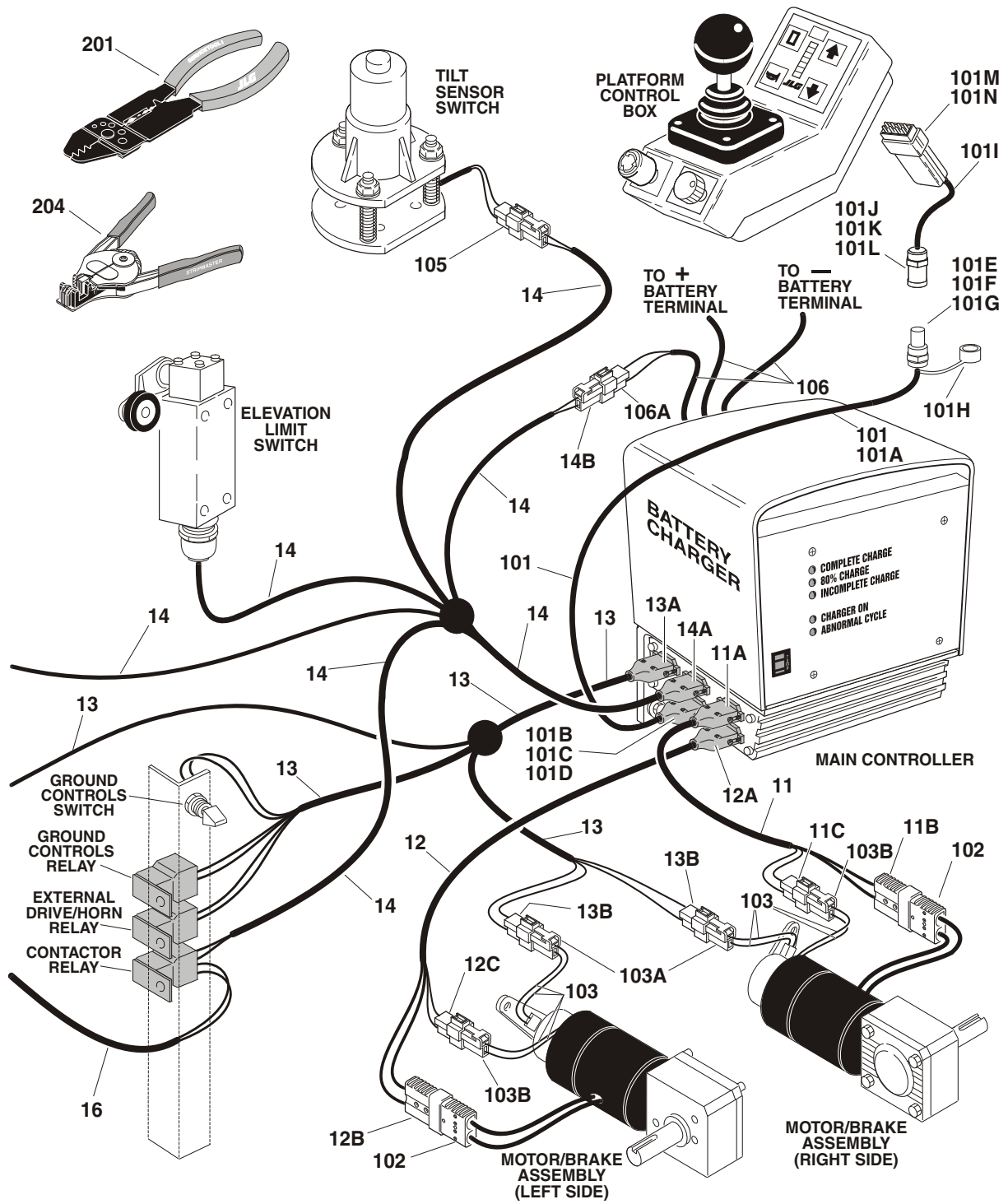

**SECTION 7 ELECTRICAL**

# SECTION 7 ELECTRICAL

**FIGURE 7-3. ELECTRICAL COMPONENTS INSTALLATION**

FIG & ITEM #	PART NUMBER	DESCRIPTION	QTY.	REV.
		<b>ELECTRICAL SYSTEM INSTALLATIONS</b>	Ref.	
	0259776	<b>Prior to S/N 03620</b>	Ref.	E
	0271478	<b>S/N 03620 to Present</b>	Ref.	A
1	1060618	Cable, Battery - 40"	1	
2	1060619	Cable, Battery - 24"	1	
3	1060620	Cable, Battery - 21"	2	
4 to 10	Not Used			
11	4921963	Harness, Right Motor	1	
11A	4460644	Receptacle - 5 Pin	1	
	4460645	Shell, Receptacle	2	
11B	4460648	Receptacle - 2 Position	1	
11C	4460320	Connector, Female - 2 Position	1	
	4460267	Pin	1	
	4460268	Socket	2	
12	4921964	Harness, Left Motor	1	
12A	4460644	Receptacle - 5 Pin	1	
	4460645	Pin	2	
12B	4460648	Receptacle - 2 Position	1	
12C	4460320	Connector, Female - 2 Position	1	
	4460267	Pin	1	
	4460268	Socket	2	
13	4921965	Harness, Valve & Limit Switch (Prior to S/N 03083)	1	
	4922492	Harness, Valve & Limit Switch (S/N 03083 to S/N 03620)	1	
	4922617	Harness, Valve & Limit Switch (S/N 03620 to Present)	1	
	3990010	Diode	A/R	
13A	4460681	Receptacle - 15 Pin	1	
	4460643	Shell, Receptacle	1	
	4460684	Socket	8	
13B	4460424	Connector, Male - 2 Position	2	
	4460267	Pin	2	
	4460268	Socket	2	
13C	2400006	Fuse - 5 Amp	1	
	4460044	Fuseholder	1	
14	4921966	Harness, Controller Power	1	
	3990010	Diode	2	
14A	4460646	Receptacle - 5 Pin	1	
	4460647	Shell, Receptacle	2	
14B	4460320	Connector, Female - 2 Position	1	
	4460268	Socket	2	
15	4921967	Harness, Key Switch Power	1	
15A	2400006	Fuse - 5 Amp	1	
	4460044	Fuseholder	1	
16	4921968	Harness, Main Contactor	1	
	3990010	Diode - 6 Amp	2	
17	4921969	Harness, E-Stop (Located Inside Control Box)	1	
18	4460234	Strap, Tie (Not Shown)	2	

**SECTION 7 ELECTRICAL**

# SECTION 7 ELECTRICAL

**FIGURE 7-3. ELECTRICAL COMPONENTS INSTALLATION**

FIG & ITEM #	PART NUMBER	DESCRIPTION	QTY.	REV.
19	4240032	Strap, Tie (Not Shown)	6	
20	4240033	Strap, Tie (Not Shown)	4	
		<b>STANDARD HARNESS ASSEMBLIES</b>	Ref.	
101	4922203	Harness, Ground to Platform	1	
101A	1060616	Cable, Shielded	A/R	
101B	4460682	Terminal, 15 Pin	1	
101C	4460643	Terminal, 15 Pin	1	
101D	4460683	Terminal, Pin	8	
101E	4460771	Terminal Plug, Male	1	
101F	4460773	Backshell	1	
101G	4460775	Pin, Male	9	
101H	4460774	Cap, Dust	1	
101I	7020216	Harness, Connector (Includes Items 101J, 101K, 101L, 101M & 101N)	1	
101J	4460772	Terminal Plug, Female	1	
101K	4460773	Backshell	1	
101L	4460776	Pin, Female	9	
101M	4460671	Terminal, 12 Pin	1	
101N	4460672	Terminal, Female	9	
102	4460648	Terminal (Harness Supplied with Drive Motor Only)	2	
103	Not Available	Harness Assembly - Brake	2	
103A	4460320	Connector, Female - 2 Position	2	
	4460268	Socket	1	
	4460267	Pin	1	
103B	4460424	Connector, Male - 2 Position	1	
	4460268	Socket	1	
	4460267	Pin	1	
104	Not Available	Beacon Light Harness Assembly	1	
105	4460445	Receptacle - 3 Position (Attach to #14 for Tilt Sensor)	1	
	4460227	Pin	3	
106	7018567	DC Battery Charger Harness Assembly	1	
106A	7011621	Connector, Male - 2 Position	1	
	4460267	Pin, Male	2	
		<b>TOOLS</b>	Ref.	
	0100048	Compound, Silicone (Use on Connectors/ Receptacles)	A/R	
201	7002821	Crimper (For Wire to Pin/Socket Connections)	1	
202	7002830	Extractor (For Removal of Pin/Socket from Connectors) (Not Shown)	1	
203	Not Used			
204	7002828	Stripper, Wire	1	

**SECTION 7 ELECTRICAL**

# SECTION 7 ELECTRICAL

FIGURE 7-3. ELECTRICAL COMPONENTS INSTALLATION

FIG & ITEM #	PART NUMBER	DESCRIPTION	QTY.	REV.

**S  
E  
C  
T  
I  
O  
N  
  
7  
  
E  
L  
E  
C  
T  
R  
I  
C  
A  
L**

# SECTION 8 DECALS

TABLE OF CONTENTS		
FIGURE	DESCRIPTION	PAGE
8-1	DECALS INSTALLATION .....	8-2

**S  
E  
C  
T  
I  
O  
N  
  
8  
  
D  
E  
C  
A  
L  
S**

# SECTION 8 DECALS

FIGURE 8-1.DECALS INSTALLATION

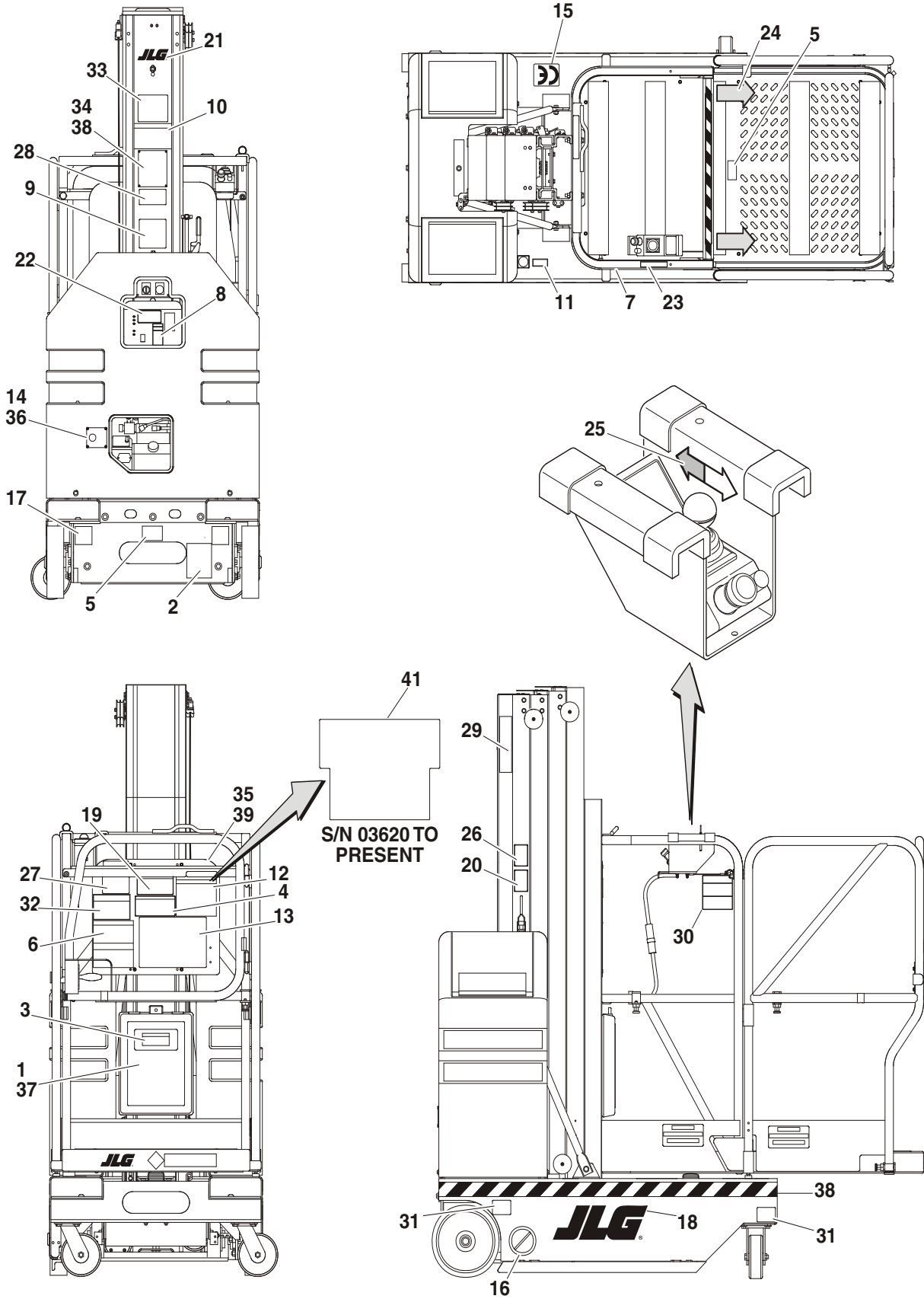

SECTION 8 DECALS



# SECTION 8 DECALS

**FIGURE 8-1. DECALS INSTALLATION**

FIG & ITEM #	PART NUMBER	DESCRIPTION	QTY.	REV.
	0270637	<b>DECAL INSTALLATION</b>	Ref.	C
1	0860520	Box, Manual Storage	1	
2	1700584	Decal - Patent	1	
3	1702110	Decal - Read Instructions	1	
4	1702282	Decal - Warning (Prior to S/N 03620)	1	
5	1702300	Decal - Tie Down	2	
6	1702361	Decal - Electrical Hazard (Prior to S/N 03620)	1	
7	1702364	Decal - Crushing	2	
8	1702437	Decal - Explosion/Fire Hazard	1	
9	Not Available	Decal - Bar Code	1	
10	1702885	Decal - Daily Checklist	1	
11	1702886	Decal - Leveling	1	
12	1702887	Decal - Operation (Prior to S/N 03620)	1	
13	1702905	Decal - Joystick (Prior to S/N 03620)	1	
14	1702922	Decal - Manual Decent (Prior to S/N 03620)	1	
15	1702928	Decal - CE	1	
16	1703072	Decal - No Forklift	2	
17	1703073	Decal - Fork Pockets	2	
18	1703625	Decal - JLG	2	
19	1703635	Decal - Brakes (Prior to S/N 03620)	1	
20	1703636	Decal - Brakes	1	
21	1703681	Decal - JLG	1	
22	1703682	Decal - Charger Cord Location	1	
23	1703684	Decal - Control Box Location	1	
24	1703687	Decal - Arrow	2	
25	1703688	Decal - Arrow	2	
26	1703708	Decal - Towing/Winching	1	
27	1704366	Decal - Fall Hazard (Prior to S/N 03620)	1	
28	1704458	Decal - JLG Manufacturing	1	
29	1704467	Decal - Model Designation	3	
30	1704527	Decal - Operation	1	
31	1704539	Decal - Wheel Load	4	
32	1704785	Decal - Maximum Capacity (Prior to S/N 03620)	1	
33	3251813	Decal - USA	1	
34	Not Available	Nameplate, Serial Number	1	
35	3380441	Panel, Control	1	
36	3820006	Rivet (Prior to S/N 03620)	4	
37	3820024	Rivet	4	
38	3820031	Rivet	4	
39	3820032	Rivet	4	
40	4420051	Tape, Safety	A/R	
41	1704890	Decal - Warning/Instruction (S/N 03620 to Present)	1	

**SECTION 8 DECALS**

# SECTION 8 DECALS

FIGURE 8-1. DECALS INSTALLATION (CONTINUED)

FIG & ITEM #	PART NUMBER	DESCRIPTION	QTY.	REV.

**S  
E  
C  
T  
I  
O  
N  
  
8  
  
D  
E  
C  
A  
L  
S**

# SECTION 9 RECOMMENDED SERVICE PARTS STOCK

## VPSP SERIES

The following list will service fleets of machines (built to current production per date on the front cover) with emergency repair parts which can be installed in the field. Parts from the list should be replaced when inventory is depleted to keep service parts stock supplied. For further information, contact your JLG dealer or the JLG Industries Parts Department.

JLG PART NUMBER	DESCRIPTION	QTY PER FLEET		
		1-10	10-20	20 OR MORE
<b>STANDARD PARTS</b>				
3740069	Relay, Power 24 VDC (Figure 1-1 & 2-1)	1	1	1
4360314	Switch, Toggle (Figure 1-1)	1	1	1
4360465	Switch, Tilt (Figure 1-1)	1	1	1
7014117	Switch, Micro (Figure 1-2)	1	1	1
4360456	Switch, Limit (Figure 1-4)	1	1	1
0861330	Ground Control Box (Figure 2-1)	1	1	1
1600305	Controller (Figure 2-1)	1	1	1
3740130	Relay 100-Amp (Figure 2-1)	1	1	1
4360437	Switch, Limit (Figure 2-1)	1	1	1
1600304	Controller, Joystick (Figure 2-2)	1	1	1
7018551	Transformer (Figure 2-3)	1	1	1
7018564	Relay, Interlock (Figure 2-3)	1	1	1
7018557	Breaker, Circuit - AC (Figure 2-3)	1	1	1
7011509	Breaker, Circuit - DC (Figure 2-3)	1	1	1
7016735	Coupling (Figure 2-4)	1	1	1
7013723	Filter - 149 Micron (Figure 2-4)	1	1	1
7016714	Breather (Figure 2-4)	1	1	1
7016711	Solenoid, Start (Figure 2-4)	1	1	1
3990010	Diode (Figure 7-3)	2	2	2
2400006	Fuse - 5 Amp (Figure 7-3)	2	2	2

# SECTION 9 RECOMMENDED SERVICE PARTS

SECTION 9 RECOMMENDED SERVICE PARTS STOCK

## VPSP SERIES

The following list will service fleets of machines (built to current production per date on the front cover) with emergency repair parts which can be installed in the field. Parts from the list should be replaced when inventory is depleted to keep service parts stock supplied. For further information, contact your JLG dealer or the JLG Industries Parts Department.

JLG PART NUMBER	DESCRIPTION	QTY PER FLEET		
		1-10	10-20	20 OR MORE

# SECTION 10 SPECIAL OPTIONS

Note: This list is to accommodate machines ordered with special equipment. Options may not be applicable to all models. For more specific parts information contact JLG Parts Department.				
FIG & ITEM #	PART NUMBER	DESCRIPTION	QTY.	REV.
	0272004	<b>CYCLE COUNTER</b>	Ref.	
		<b>ELECTRICAL CONNECTOR KITS</b>	Ref.	
	1001148902	Amp/Tyco Electrical Connector Kit	Ref.	
	1001148903	Deutsch DT Electrical Connector Kit	Ref.	
	1001148904	Deutsch HD Electrical Connector Kit	Ref.	
	1001148905	Packard Electrical Connector Kit	Ref.	
	1001148906	Various Electrical Connectors Kit	Ref.	
	0255040	<b>FLUORESCENT TUBE CADDY</b>	Ref.	
	0258799	<b>MATERIAL TRAY</b>	Ref.	
	0271198	<b>RUG CARRIER</b>	Ref.	
		<b>Note: For Breakdown of Obstruction Sensing System Refer to Obstruction Sensing Manual p/n 3124289</b>		
		<b>TOOLS</b>	Ref.	
	0100048	Compound, Silicone (Use on Connectors/ Receptacles)	A/R	
	7002821	Crimper (For Wire to Pin/Socket Connections)	1	
	7002830	Extractor (For Removal of Pin/Socket from Connectors)	1	
	7002828	Stripper, Wire	1	
	1001137005	Cable Kit, Software (Not Shown)	1	

SECTION 10 SPECIAL OPTIONS

# SECTION 10 SPECIAL OPTIONS

## SECTION 10 SPECIAL OPTIONS

Note: This list is to accommodate machines ordered with special equipment. Options may not be applicable to all models. For more specific parts information contact JLG Parts Department.

FIG & ITEM #	PART NUMBER	DESCRIPTION	QTY.	REV.

## SECTION 11 PART NUMBER INDEX

Part Number	Page	Part Number	Page	Part Number	Page	Part Number	Page
0100011	1-3, 1-7, 1-13, 3-3, 4-3, 4-7, 4-11, 4- 15	0630446	1-3	1060620	7-6	1704980	4-4, 4-7
0100019	1-4, 1-7	0630504	2-3	1060649	1-13	1704981	4-4, 4-8
0100020	6-3, 6-5	0630545	4-7	1060658	1-3, 1-4	2020005	4-11
0100035	1-4, 1-7, 1-13	0641405	1-13	1060661	1-4	2080040	4-3, 4-7
0100048	7-7, 10-1	0641406	1-3, 1-4, 2-3, 3-3	1060662	1-4	2220415	6-5
0100062	3-5	0641407	3-3	1060683	3-3	2220416	6-3
0140022	2-3	0641408	3-4, 4-11, 4-15	1100103	1-13	2220472	6-3, 6-5
0140033	2-3	0641410	2-7, 3-3	1260355	3-4, 3-5	2220473	6-3, 6-5
0181857	2-3	0641414	4-11	1260356	3-4, 3-5	2220507	6-3
0255040	10-1	0641416	4-12, 4-15	1260357	3-4, 3-5	2220603	6-3, 6-5
0256851	1-7	0641508	2-3, 3-3	1271392	3-3	2220875	6-3
0257490	1-13	0641510	3-3	1271419	3-3	2400006	7-6, 9-1
0258448	3-9	0641528	1-4	1271421	3-3	2420140	1-4
0258586	4-11	0641606	2-4	1271455	3-3	2420165	1-3
0258672	4-15	0641608	1-4	1271471	3-3	2560150	1-4
0258718	1-7	0641609	1-3, 1-4, 1-7, 2-3	1320043	2-7	2560154	4-11
0258799	10-1	0641610	1-7	1320149	2-7	2600225	4-11
0259350	4-3	0641612	1-4, 3-9	1380132	2-7, 4-12	2680483	2-3
0259527	1-4	0641616	4-3, 4-7	1400126	1-7, 1-8	2700080	2-3
0259528	2-3	0641620	4-3, 4-7	1600304	2-7, 2-13, 9-1	2792403	6-3
0259769	2-7	0641711	1-7	1600305	2-3, 9-1	2792491	6-5
0259774	2-4, 6-3	0641810	1-4	1683808	3-3, 5-3	2820085	1-3
0259776	7-6	0641812	3-3, 3-9	1684142	3-3, 5-3	2860027	1-7
0270065	4-3	0720805	4-11	1700584	8-3	2860029	1-7
0270352	1-4	0721006	2-3, 4-11	1702110	8-3	2860030	2-3
0270438	4-7	0721008	1-3, 4-3, 4-7	1702282	8-3	2880310	3-3
0270440	4-7	0741006	3-3	1702300	8-3	2920146	1-3
0270512	4-15	0741407	2-3	1702361	8-3	2940074	4-3, 4-7, 4-11
0270513	4-11	0741605	2-4	1702364	8-3	2940082	4-15
0270535	1-3	0741606	3-3	1702437	8-3	3020022	1-13
0270637	8-3	0741609	1-7	1702437	8-3	3160234	1-7, 1-11
0271198	10-1	0801211	3-3, 3-9	1702885	8-3	3250030	4-11
0271407	4-3	0801313	3-3	1702886	8-3	3251813	8-3
0271408	4-7	0860520	8-3	1702887	8-3	3271805	3-9
0271465	1-4	0861330	2-3, 9-1	1702905	8-3	3300151	4-15
0271466	2-4, 6-5	0880139	1-4	1702922	8-3	3300202	2-3
0271478	7-6	0902047	3-3	1702923	1-3	3300356	4-12
0272004	10-1	0902250	2-3	1702928	8-3	3300417	2-7
0362347	4-15	0902356	2-3	1703072	8-3	3310601	1-3
0362658	2-3	0902422	3-3	1703073	8-3	3310801	2-7
0362735	3-3	0902423	3-3	1703455	3-9	3310805	4-11
0362736	3-3	0902424	3-3	1703625	8-3	3310805	4-11
0400122	2-3	0902424	3-3	1703635	8-3	3311001	2-3, 4-3, 4-7, 4-15
0400157	2-9	0902431	3-3	1703636	8-3	3311005	1-3, 1-13, 2-3, 4-11, 4-12, 4-15
0400164	2-3	0902445	3-3	1703681	4-4, 4-7, 4-11, 8-3	3311401	3-3
0400166	2-9	0902583	1-3	1703682	8-3	3311405	1-3, 2-3, 2-7, 4-11, 4-15
0440221	1-7	0902698	3-4	1703684	8-3	3311501	1-4, 4-3, 4-7
0440225	3-4	0902877	4-11	1703687	8-3	3311505	4-11, 4-15
0440230	3-4	0940049	4-3, 4-7	1703688	8-3	3311601	3-3
0440246	3-4	0962337	4-3, 4-7	1703708	8-3	3311605	1-3, 1-4, 1-7, 2-3, 2- 7, 3-9, 4-3, 4-7
0440294	3-4	1001137005	10-1	1704277	3-9, 4-4, 4-7	3311705	1-7
0561149	3-5	1001148902	10-1	1704366	8-3	3311801	3-3
0561284	1-4	1001148903	10-1	1704458	4-4, 4-7, 8-3	3311805	1-4
0561308	3-5	1001148904	10-1	1704467	4-4, 4-7, 8-3	3312002	1-13
0561336	3-5	1001148905	10-1	1704469	4-4, 4-7	3340746	4-15
0561341	3-3	1001148906	10-1	1704527	8-3	3340754	4-15
0561408	3-5	1060380	2-7, 4-11, 4-15	1704527	8-3	3340829	4-11
		1060616	7-7	1704539	8-3		
		1060618	7-6	1704582	1-4		
		1060619	7-6	1704785	8-3		
				1704890	8-3		

# SECTION 11 PART NUMBER INDEX

Part Number	Page	Part Number	Page	Part Number	Page	Part Number	Page
3340845	3-3	3760170	2-7	4300129	3-5	4740414	3-4
3340858	3-3	3760383	3-4	4360314	1-3, 9-1	4740428	4-15
3380441	8-3	3760448	4-3, 4-7	4360437	2-3, 9-1	4740429	4-15
3422338	3-3, 3-5	3820006	8-3	4360456	1-13, 9-1	4740430	1-3
3422346	3-5	3820024	2-7, 4-15, 8-3	4360465	1-3, 9-1	4740478	1-7
3422355	3-5	3820031	8-3	4360469	2-3	4750600	1-3, 1-13
3422657	2-7, 4-11, 4-15	3820032	4-3, 4-7, 8-3	4420039	4-3, 4-7, 4-11	4750800	1-7, 2-7, 3-4, 4-11
3422717	3-3	3820034	3-4	4420051	8-3	4751000	1-3, 2-3, 2-7, 4-3, 4-7, 4-11, 4-15
3422720	3-5	3841343	1-13	4460044	7-6	4751400	2-3, 4-15
3422744	4-3, 4-7	3900032	4-11	4460227	7-7	4751500	2-3, 2-7, 3-4, 3-5, 3-6, 4-3, 4-7, 4-15
3422750	3-3	3900177	4-15	4460234	7-6	4751600	1-3, 1-4, 1-7, 1-13, 2-4
3422752	3-3	3900187	3-4	4460267	2-9, 7-6, 7-7	4751800	1-4, 3-9
3422757	3-3	3900192	3-4	4460268	7-6, 7-7	4761000	3-4, 4-3, 4-7
3422866	4-3, 4-7	3900200	2-7, 4-11	4460320	7-6, 7-7	4761400	3-4
3430630	1-13	3900202	1-13, 4-15	4460424	2-9, 7-6, 7-7	4761500	3-4
3430638	1-13	3900203	4-15	4460445	7-7	4845291	1-4
3440418	1-13	3900205	3-4	4460633	2-3	4845345	3-9
3440520	1-7	3900221	1-7	4460643	7-6, 7-7	4845473	1-7
3450202	3-5	3900248	1-4	4460644	7-6	4845474	1-4
3450304	3-3, 3-5	3900249	1-13	4460645	7-6	4845507	1-13
3450403	1-13	3900252	4-11	4460646	7-6	4845508	1-13
3510676	4-15	3900258	4-11	4460647	7-6	4845509	1-13
3520028	4-15	3900270	4-3, 4-7	4460648	1-3, 7-6, 7-7	4845614	4-11
3520072	4-11, 4-15	3910620	1-3, 1-13	4460662	1-13	4845657	4-12
3520166	2-3	3911010	1-3, 2-3	4460671	7-7	4845731	3-4
3520176	4-3, 4-7	3911024	2-3	4460672	7-7	4845810	4-11
3539814	3-9	3911032	4-15	4460681	7-6	4845811	4-11
3570168	1-7	3930808	1-7	4460682	7-7	4845812	4-11
3570169	1-7	3990010	7-6, 9-1	4460683	7-7	4845822	4-15
3570172	1-4	4040268	1-7	4460684	7-6	4845831	4-15
3570230	1-13	4060803	4-12, 4-15	4460685	2-3	4845875	2-3
3570274	4-11	4060882	4-15	4460771	7-7	4845876	2-3
3570362	4-11	4060960	3-4	4460772	7-7	4845878	2-3
3570382	1-4	4060961	3-4	4460773	7-7	4846021	4-15
3570653	4-12	4061006	3-4	4460774	7-7	4846030	4-3
3570654	4-12	4070860	3-4	4460775	7-7	4846034	4-3
3570680	2-7	4070861	3-4	4460776	7-7	4846035	4-3
3570737	2-7	4070862	3-4	4567203	1-13	4846087	1-3
3570893	3-3	4070890	4-15	4567489	3-4	4846129	4-3, 4-7
3570976	3-9	4070894	4-15	4567492	3-4	4846173	1-4
3571101	3-5	4070970	3-4	4567749	3-5	4846323	4-3, 4-7
3571103	3-5	4070971	3-4	4567750	3-4	4846324	4-3, 4-7
3571552	4-3, 4-7	4070988	3-5	4567751	3-5	4846325	4-3, 4-7
3571788	3-3	4070989	3-5	4568026	6-3	4846381	3-4
3571790	3-3	4070990	3-5	4568027	6-3	4846521	4-3
3580231	2-7	4160124	3-4	4568285	6-5	4846921	4-11
3580249	3-4	4160125	4-15	4568286	6-5	4860175	1-3
3580267	3-4	4160130	2-7	4640956	6-3	4860177	1-3
3580268	3-4	4160160	1-13	4711400	1-3, 1-4, 1-13, 2-3, 2-7, 3-4, 4-11, 4-15	4921963	7-6
3580269	3-4	4160162	1-13			4921964	7-6
3580274	3-4	4160164	1-3			4921965	7-6
3580275	3-4	4160165	4-11	4711500	3-4, 4-11	4921966	7-6
3580285	3-4	4160166	1-4	4711600	1-4, 2-3, 3-9, 4-3, 4-4, 4-7, 4-11	4921967	7-6
3580286	3-4	4240032	7-7			4921968	7-6
3600254	2-4, 2-11	4240033	1-4, 7-7	4711700	1-7	4921969	7-6
3640924	4-15	4240084	1-4	4711800	3-4	4922203	2-7, 7-7
3640990	4-15	4280296	4-3, 4-7, 4-12	4712000	1-13		
3740069	1-3, 2-3, 9-1	4300106	1-3	4712600	3-4		
3740130	2-3, 9-1	4300111	3-5	4740007	3-5		



## SECTION 11 PART NUMBER INDEX

Part Number	Page	Part Number	Page	Part Number	Page	Part Number	Page
4922492	7-6	7016723	2-11	7022205	2-11		
4922617	7-6	7016724	2-11	7022206	2-11		
7002821	7-7, 10-1	7016735	2-11, 9-1	7023201	2-13		
7002828	7-7, 10-1	7017717	2-11	7023202	2-13		
7002830	7-7, 10-1	7018000	1-11	7023351	1-8		
7003246	5-3	7018001	1-11	7023352	1-8		
7011509	2-9, 9-1	7018002	1-11	7023353	1-8		
7011528	2-9	7018005	1-11	7023354	1-8		
7011621	7-7	7018007	1-11	7023355	1-8		
7011649	2-9	7018008	1-11	7023356	1-8		
7012958	5-3	7018009	1-11	7023357	1-8		
7012998	5-3	7018010	1-11	7023358	1-8		
7013701	2-11	7018011	1-11	7023359	1-8		
7013708	2-11	7018012	1-11	7023360	1-8		
7013713	2-11	7018013	1-11	7023361	1-8		
7013714	2-11	7018014	1-11	7023391	5-3		
7013715	2-11	7018015	1-11	7023392	5-3		
7013716	2-11	7018018	1-11	7023393	5-3		
7013717	2-11	7018019	1-11	7023394	5-3		
7013720	2-11	7018027	1-11	7023395	5-3		
7013722	2-11	7018028	1-11	7023397	5-3		
7013723	2-11, 9-1	7018537	2-9	7023398	5-3		
7013727	2-11	7018551	2-9, 9-1	7023399	5-3		
7013728	2-11	7018554	2-9	7024354	5-3		
7013733	2-11	7018555	2-9	7026038	2-13		
7013743	2-11	7018556	2-9	7026039	2-13		
7013750	2-11	7018557	2-9, 9-1				
7013758	2-11	7018562	2-9				
7013759	2-11	7018563	2-9				
7013766	2-11	7018564	2-9, 9-1				
7013770	2-11	7018567	2-9, 7-7				
7013791	2-11	7018586	2-9				
7013792	2-11	7018589	2-9				
7013793	2-11	7019659	1-3				
7014117	1-7, 9-1	7019660	1-3				
7014118	1-7	7019661	1-3				
7014119	1-7	7019662	1-3				
7014120	1-7	7019663	1-3				
7016319	1-3	7019834	5-3				
7016372	1-3	7019835	5-3				
7016683	1-7	7019838	5-3				
7016684	1-7	7019839	5-3				
7016685	1-7	7019865	5-3				
7016686	1-7	7019872	5-3				
7016687	1-7	7020075	2-7				
7016688	1-8	7020076	2-7				
7016689	1-7	7020078	2-3				
7016690	1-7	7020093	2-3				
7016691	1-7	7020094	2-3				
7016710	2-11	7020096	2-3				
7016711	2-11, 9-1	7020097	2-3				
7016712	2-11	7020139	2-13				
7016713	2-11	7020142	2-13				
7016714	2-11, 9-1	7020143	2-13				
7016718	2-11	7020144	2-13				
7016719	2-11	7020145	2-13				
7016720	2-11	7020147	2-13				
7016721	2-11	7020216	7-7				
7016722	2-11	7020620	2-9				

# SECTION 11 PART NUMBER INDEX

Part Number	Page	Part Number	Page	Part Number	Page	Part Number	Page
-------------	------	-------------	------	-------------	------	-------------	------



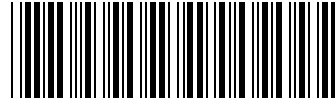

3121822



An Oshkosh Corporation Company

Corporate Office  
JLG Industries, Inc.  
1 JLG Drive  
McConnellsburg PA. 17233-9533  
USA

☎ (717) 485-5161

📠 (717) 485-6417

## JLG Worldwide Locations

JLG Industries (Australia)  
P.O. Box 5119  
11 Bolwarra Road  
Port Macquarie  
N.S.W. 2444  
Australia

☎ +61 2 65 811111

📠 +61 2 65 813058

JLG Latino Americana Ltda.  
Rua Eng. Carlos Stevenson,  
80-Suite 71  
13092-310 Campinas-SP  
Brazil

☎ +55 19 3295 0407

📠 +55 19 3295 1025

JLG Industries (UK) Ltd  
Bentley House  
Bentley Avenue  
Middleton  
Greater Manchester  
M24 2GP - England

☎ +44 (0)161 654 1000

📠 +44 (0)161 654 1001

JLG France SAS  
Z.I. de Baulieu  
47400 Fauillet  
France

☎ +33 (0)5 53 88 31 70

📠 +33 (0)5 53 88 31 79

JLG Deutschland GmbH  
Max-Planck-Str. 21  
D - 27721 Ritterhude - Ihlpohl  
Germany

☎ +49 (0)421 69 350 20

📠 +49 (0)421 69 350 45

JLG Equipment Services Ltd.  
Rm 1107 Landmark North  
39 Lung Sum Avenue  
Sheung Shui N. T.  
Hong Kong

☎ (852) 2639 5783

📠 (852) 2639 5797

JLG Industries (Italia) s.r.l.  
Via Po. 22  
20010 Pregnana Milanese - MI  
Italy

☎ +39 029 359 5210

📠 +39 029 359 5845

Oshkosh-JLG Singapore  
Technology Equipment Pte  
Ltd  
29 Tuas Ave 4,  
Jurong Industrial Estate  
Singapore, 639379

☎ +65-6591 9030

📠 +65-6591 9031

Plataformas Elevadoras  
JLG Iberica, S.L.  
Trapadella, 2  
P.I. Castellbisbal Sur  
08755 Castellbisbal, Barcelona  
Spain

☎ +34 93 772 4700

📠 +34 93 771 1762

JLG Sverige AB  
Enkopingsvagen 150  
Box 704  
SE - 176 27 Jarfalla  
Sweden

☎ +46 (0)850 659 500

📠 +46 (0)850 659 534