



Illustrated Parts Manual

Model 10MSP

Prior to SN 0130032507

P/N
3121229

February 28, 2018

ANSI

CE



AS/NZS



An Oshkosh Corporation Company

REVISION LOG

NOTES: Machines SN 0130032134 - 0130032138 Built to 1001229200 Specs.
Use Parts Manual P/N 3121780 for Replacement Parts.

PARTS MANUAL REVISION LOG:

January 1, 2006 - Original Issue Of Manual (Edited to B/M 0010680 Revision 3)
May 15, 2006 - Revised Manual (Edited to B/M 0010680 Revision 3)
October 31, 2006 - Revised Manual (Edited 0010680 to Revision 6)
March 1, 2007 - Revised Manual (Edited 0010680 to Revision 7)
November 16, 2007 - Revised Manual (Edited 0010680 to Revision 10)
January 15, 2008 - Revised Manual (Edited 0010680 to Revision 10)
August 27, 2008 - Revised Manual (Edited 0010680 to Revision 11)
August 18, 2009 - Revised Manual (Edited 0010680 to Revision 12)
February 24, 2011 - Revised Manual (Edited 0010680 to Revision 13)
May 27, 2011 - Revised Manual (Edited 0010680 to Revision 13)
August 15, 2011 - Revised Manual (Edited 0010680 to Revision 14)
November 15, 2011 - Revised Manual (Edited 0010680 to Revision 14)
February 28, 2012 - Revised Manual (Edited 0010680 to Revision 14)
July 10, 2012 - Revised Manual (Edited 0010680 to Revision C)
September 28, 2012 - Revised Manual (Edited 0010680 to Revision C)
February 6, 2013 - Revised Manual (Edited 0010680 to Revision D)
May 6, 2013 - Revised Manual (Edited 0010680 to Revision D)
August 6, 2013 - Revised Manual (Edited 0010680 to Revision D)
November 1, 2013 - Revised Manual (Edited 0010680 to Revision D)
October 1, 2014 - Revised Manual (Edited to 0010680 Revision D)
March 20, 2015 - Revised Manual (Edited to 0010680 Revision E)
August 10, 2015 - Revised Manual (Edited to 0010680 Revision E)
November 6, 2015 - Revised Manual (Edited to 0010680 Revision E)
February 5, 2016 - Revised Manual (Edited to 0010680 Revision E)
May 6, 2016 - Revised Manual (Edited to 0010680 Revision E)
August 1, 2016 - Revised Manual (Edited to 0010680 Revision E)
November 22, 2016 - Revised Manual (Edited to 0010680 Revision E)
February 15, 2017 - Revised Manual (Edited to 0010680 Revision E)
May 31, 2017 - Revised Manual (Edited to 0010680 Revision F and 1001207555 Revision A)
August 11, 2017 - Revised Manual (Edited to 0010680 Revision F and 1001207555 Revision D)
October 16, 2017 - Revised Manual (Edited to 0010680 Revision F and 1001207555 Revision E)
February 28, 2018 - Revised Manual (Edited to 0010680 Revision F and 1001207555 Revision E)

GENERAL INFORMATION

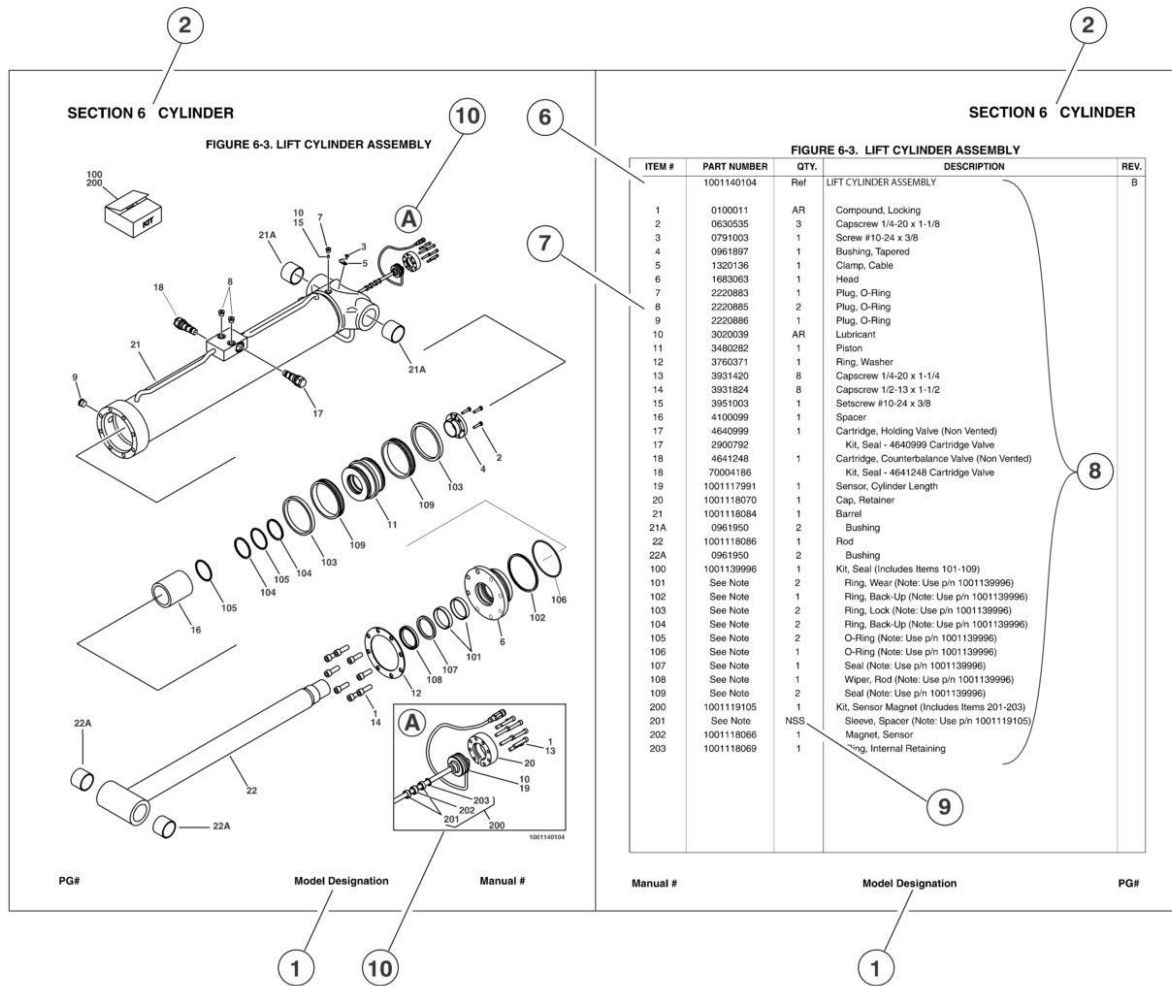

1) MACHINE IDENTIFICATION

Machines are identified by model and in some cases a combination of models, serial number (SN) or regional standard (i.e ANSI, CE, CSA). Components may also be identified by SN or manufacturer. Common components that may be identified by these characteristics are engines and hydraulic components.

2) PARTS MANUAL ORGANIZATION

Product information in this manual is organized under section titles. Frame, Cylinder, Hydraulic and Electrical are a few examples. Each section is organized by figure and page number. The information within the Figure is then organized by item number, part number, description and corresponding illustration (s).

3) TABLE OF CONTENTS

A table of contents is found toward the beginning of the manual. Figure number, description and page number are provided for quick reference to the page containing the related information.

4) RECOMMENDED SPARE PARTS

The Recommended Spare Parts, located near the end of the manual, reference most frequently used maintenance parts.

5) PART NUMBER INDEX

A numerical index listing all part numbers and the corresponding page number(s) appears at the back of the manual.

GENERAL INFORMATION

6) NON-SERVICED PARTS

In some instances, it is necessary to display non-serviced parts, assemblies or installations. In the case of assemblies and installations there will be a Ref in the Qty column. In case of parts that are not available for service within assemblies or components, there will be a NSS (Not Sold Separately) or NLA (No Longer Available) listed in the Qty. column of the manual.

7) PARTS LIST ITEM NUMBERS

Numbers shown in the item# column correspond to numbers used in the associated illustration (s). Item numbers which are missing from the sequence in the parts list are not used on that page

8) INDENTED PARTS DESCRIPTION

An indented part description is included in the item under which it is indented.

9) ABB REVIATION AND SYMBOLS

AC.....	.. Alternating Current	LCD.....	.. Liquid Crystal Display
ADE.....	.. Advanced Design Electronics	LED.....	.. Light Emitting Diodes
ANSI.....	.. American National Standards Institute	LH.....	.. Left Hand
AR.....	.. As Required	LSS.....	.. Load Sensing System
ASSY.....	.. Assembly	M(m).....	.. Metric/Meter
AUX.....	.. A uxiliary	MM (mm).....	.. Milimeter
AWG.....	.. American Wire Gauge	mA.....	.. Milliamps
B/M.....	.. Bill of Material	NLA.....	.. No Longer Available
CE.....	.. European Conformity	NPT.....	.. National Pipe Threads
CCW.....	.. Counter Clockwise	NSS.....	.. Not Sold Separately
cm.....	.. Centimeter	OD.....	.. Outside Diameter
CW.....	.. Clockwise	ORB.....	.. O-Ring Boss
CSA.....	.. Canadian Standards Association	ORFS.....	.. O-Ring Face Seal
CYL.....	.. Cylinder	OZ (oz).....	.. Ounces
DIA.....	.. Diameter	PG.....	.. Page
DC.....	.. Direct Current	P/N.....	.. Part Number
EMS.....	.. Emergency Stop	qt.....	.. Quarts
ENG.....	.. Engine	QTY.....	.. Quantity
FT (ft).....	.. Feet	REF.....	.. Reference
GA (Ga).....	.. Gauge	REV.....	.. Revision Level
HYD.....	.. Hydraulic	RH.....	.. Right Hand
Hz.....	.. Hertz	SAE.....	.. Society of Automotive Engineers
ID.....	.. Inside Diameter	SN.....	.. Serial Number
in.....	.. inches	SPEC(S).....	.. Specifications
ISO.....	.. International Organization for Standards	T/T.....	.. Turntable
JIC.....	.. Joint Industry Council	UGM.....	.. Universal Ground Module
KG.....	.. Kilogram	V.....	.. Volts
L.....	.. Liter	W.....	.. Watts
LB.....	.. Pounds	#.....	.. Number

10) ILLUSTRATION REFERENCE LETTERS

When necessary, illustrations may contain reference letters that are intended to track information (i. e. hoses, harnesses) from one point to another or to track visual enlargement of components to show details that may be located in another area on the illustration.

Note: Due to continuous product improvements, JLG Industries, Inc. reserves the right to make specification changes without prior notification. Contact JLG Industries, Inc. for updated information.

TABLE OF CONTENTS

SECTION 1 - BASE.....	9
FIGURE 1-1. BASE MOUNTED COMPONENTS INSTALLATION	10
FIGURE 1-2. DRIVE ASSEMBLY.....	14
FIGURE 1-3. COVERS AND TIE-DOWNS INSTALLATION (Prior to SN 0130022207).....	16
FIGURE 1-4. COVERS AND TIE-DOWNS INSTALLATION (SN 0130022207 through 0130032506)	18
SECTION 2 - CONTROLS	21
FIGURE 2-1. PUMP MOTOR ASSEMBLY AND INSTALLATION	22
FIGURE 2-2. BATTERY CHARGER AND PLUG INSTALLATION (Prior to SN 0130010886)	26
FIGURE 2-3. BATTERY CHARGER AND PLUG INSTALLATION (SN 0130010886 through 0130032506).....	28
FIGURE 2-4. BATTERIES, SWITCHES, HORN AND BEACON LIGHT INSTALLATION	32
FIGURE 2-5. GROUND COMPONENTS INSTALLATIONS.....	36
FIGURE 2-6. PLATFORM CABLES AND CONTROLS INSTALLATION.....	38
FIGURE 2-7. CONTROL BOX ASSEMBLY.....	40
SECTION 3 - MAST	43
FIGURE 3-1. MAST ASSEMBLY AND INSTALLATION.....	44
SECTION 4 - PLATFORM.....	47
FIGURE 4-1. PLATFORM INSTALLATION	48
FIGURE 4-2. PLATFORM INSTALLATION	50
FIGURE 4-3. PLATFORM INSTALLATION	52
FIGURE 4-4. PLATFORM INSTALLATION	54
FIGURE 4-5. MATERIAL TRAY INSTALLATION	56
FIGURE 4-6. MATERIAL TRAY INSTALLATION	58
FIGURE 4-7. OPTIONAL BICYCLE CARRIERS INSTALLATION.....	60
FIGURE 4-8. OPTIONAL RUG CARRIER INSTALLATION	62
FIGURE 4-9. OPTIONAL FLUORESCENT TUBE CADDY ASSEMBLY	64
SECTION 5 - CYLINDER.....	67
FIGURE 5-1. LIFT CYLINDER ASSEMBLY (Prior to SN 0130011099).....	68
FIGURE 5-2. LIFT CYLINDER ASSEMBLY (SN 0130011099 through 0130032506)	70
SECTION 6 - HYDRAULIC	73
FIGURE 6-1. HYDRAULIC DIAGRAM.....	74
SECTION 7 - ELECTRICAL	77
FIGURE 7-1. ELECTRICAL COMPONENTS INSTALLATION.....	78
SECTION 8 - DECALS.....	85
FIGURE 8-1. DECAL INSTALLATION.....	86
SECTION 9 - RECOMMENDED SERVICE PARTS STOCK	91
FIGURE 9-1. 10MSP SERVICE PARTS.....	92
SECTION 10 - SPECIAL OPTIONS.....	93
FIGURE 10-1. SPECIAL OPTIONS.....	94
PART NUMBER INDEX	95

SECTION 1 - BASE

SECTION 1 - BASE

FIGURE 1-1. BASE MOUNTED COMPONENTS INSTALLATION

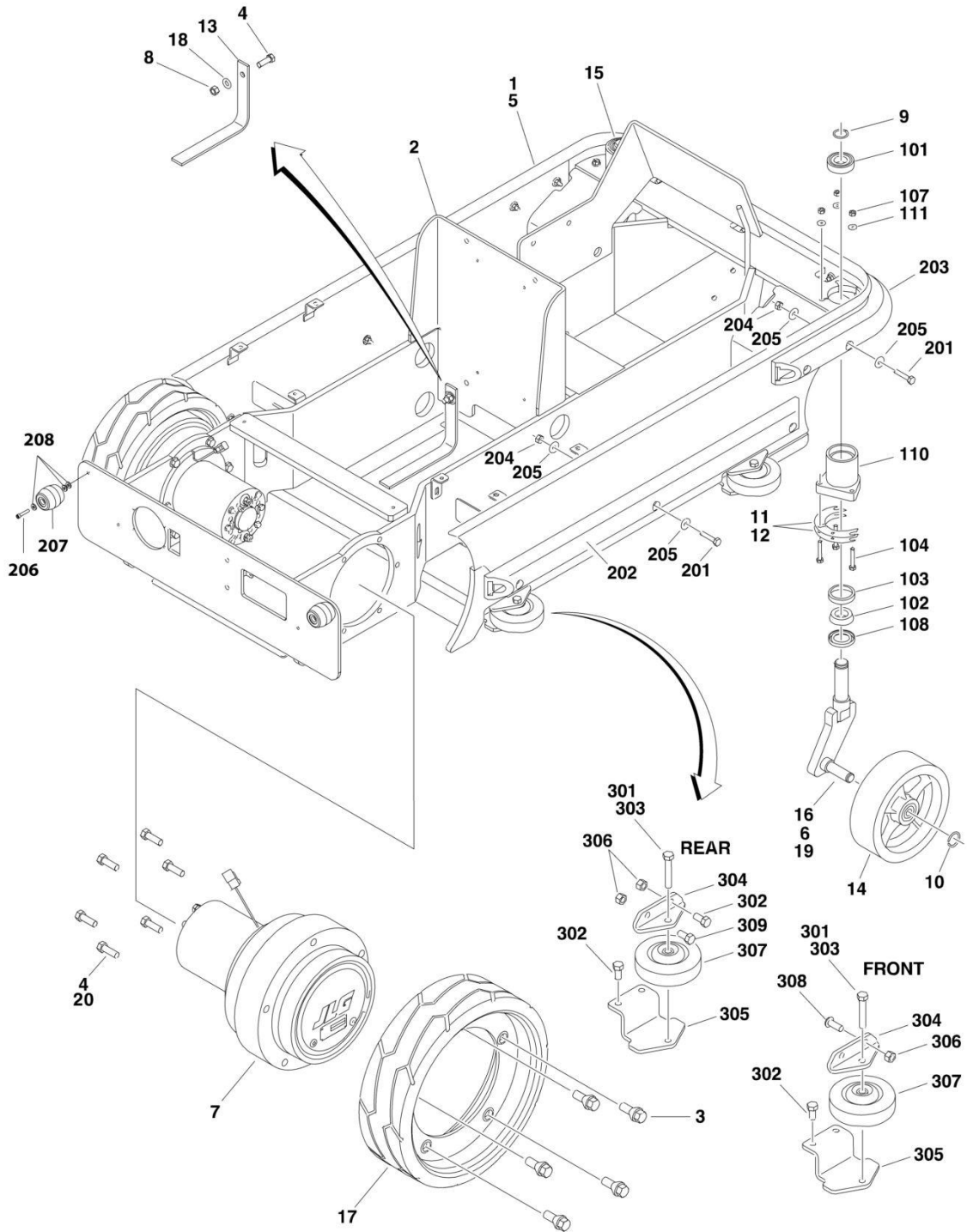

SECTION 1 - BASE

FIGURE 1-1. BASE MOUNTED COMPONENTS INSTALLATION

ITEM	PART NUMBER	QTY	DESCRIPTION	REV
	0274893	Ref	BASE ASSEMBLY	G
1	0100081	AR	Compound, Locking	
2	0274904	1	Frame Assembly (See Items 101-111 for Breakdown)	
3	0630580	10	Bolt, Wheel	
4	0641609	13	Bolt 3/8in-16NC x 1-1/8in	
5	0940132	1	Bumper, Chassis	
6	3020039	AR	Lubricant Loctite #51049	
7	3160323	2	Drive Motor Assembly (See DRIVE ASSEMBLY for Breakdown)	
8	3311605	1	Locknut 3/8in-16NC	
9	3760115	2	Ring, Retaining	
10	3760496	2	Ring, Retaining	
11	4071113	AR	Shim .015in	
12	4071114	AR	Shim .036in	
13	4240147	1	Strap, Static	
14		Ref	Tire and Wheel Assembly Options:	
14	4520281	NLA	Tire and Wheel Assembly (Use p/n 1001098810) (Prior to SN 0130011864)	
14	1001098810	2	Tire and Wheel Assembly (SN 0130011864 through 0130032506)	
15	4520342	1	Spindle (Left Side)	
16	4520343	1	Spindle (Right Side)	
17		Ref	Tire and Wheel Assembly Options:	
17	4520326	NLA	Tire and Wheel Assembly (Use p/n 1001114467) (Prior to SN 0130008686)	
17	See Note	2	Tire and Wheel Assembly (Note: Tire and Wheel Assemblies used in this range of SNs vary between old and new style - Use p/n 1001114467 as replacement.) (SN 0130008685 through 0130009365)	
17	4520565	NLA	Tire and Wheel Assembly (Use p/n 1001114467) (SN 0130009366 through 0130011758)	
17	1001100840	NLA	Tire and Wheel Assembly (Use p/n 1001114467) (SN 0130011759 through 0130013969)	
17	1001114467	2	Tire and Wheel Assembly (SN 0130013970 through 0130032506)	
18	4711600	1	Flatwasher 3/8in Narrow	
19	8882970	AR	Coating, Clear	
20	0100011	AR	Locking Compound	
	0274904	Ref	FRAME ASSEMBLY	N
101	0440306	2	Bearing, Ball	
102	0440307	2	Bearing, Roller	
103	0440308	2	Bearing, Race	
104	0641413	6	Bolt 1/4in-20NC x 1-5/8in	
106	3020029	AR	Grease (Not Shown)	
107	3271405	6	Locknut 1/4in-20NC	
108	3960590	2	Seal	
110	4341155	2	Mount, Caster	
111	4711400	6	Flatwasher 1/4in Narrow	
	0274078	Ref	BUMPERS INSTALLATION (OPTIONAL)	E
201	0641408	13	Bolt 1/4in-20NC x 1in	
202	0940152	2	Bumper, Side	
203	0940153	1	Bumper, Front (Prior to SN 0130027458)	
203	1001204273	2	Bumper, Front (SN 0130027458 through 0130032506)	

SECTION 1 - BASE

ITEM	PART NUMBER	QTY	DESCRIPTION	REV
204	3311405	AR	Locknut 1/4in-20NC	B
205	4751400	AR	Flatwasher 1/4in Wide	
206	3931420	2	Capscrew 1/4 x 1-1/4 (SN 0130027458 through 0130032506)	
207	4160187	2	Spring, Rubber (SN 0130027458 through 0130032506)	
208	4891400	6	Washer 1/4 (SN 0130027458 through 0130032506)	
	0240103	Ref	GUIDE ROLLER ATTACHMENT (OPTIONAL)	
301	0100011	AR	Locking Compound	
302	0641606	10	Bolt 3/8in-16NC x 3/4in	
303	0641617	4	Bolt 3/8in-16NC x 2-1/8in	
304	0903120	4	Bracket, Top Roller	
305	0903121	4	Bracket, Bottom Roller	
306	3311605	8	Locknut 3/8in-16NC	
307	4520352	4	Wheel	
308		Ref	Hardware Options:	
308	0641606	4	Bolt 3/8in-16NC x 3/4in (Prior to SN 0130015906)	
308	3900283	4	Screw Button Head 3/8in-16NC x 3/4in (SN 0130015906 through 0130032506)	
309		Ref	Bolt Options:	
309	0641606	2	Bolt 3/8in-16NC x 3/4in (Prior to SN 0130015906)	
309	0641609	2	Bolt 3/8in-16NC x 1-1/8in (SN 0130015906 through 0130032506)	

SECTION 1 - BASE

FIGURE 1-2. DRIVE ASSEMBLY

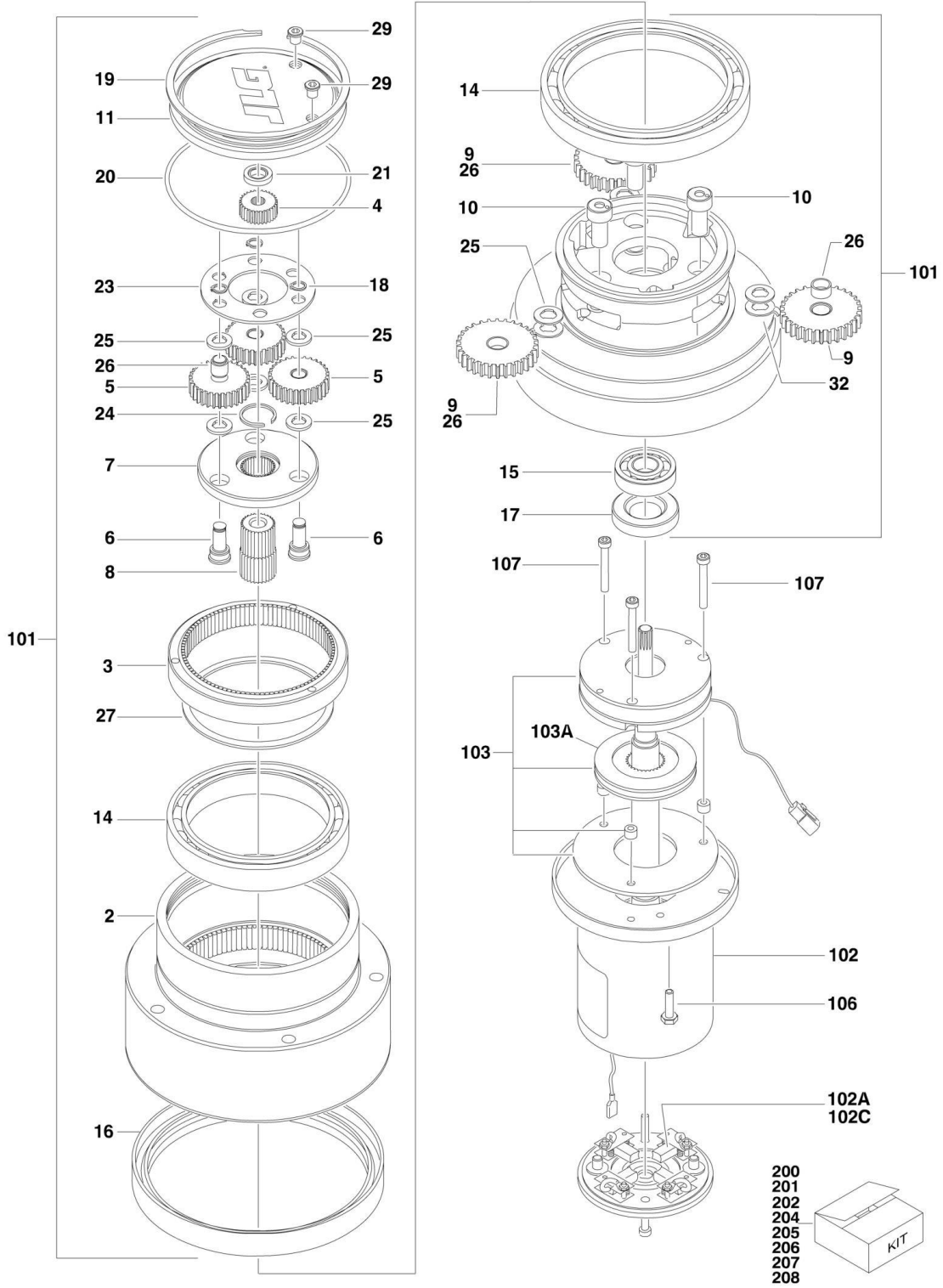
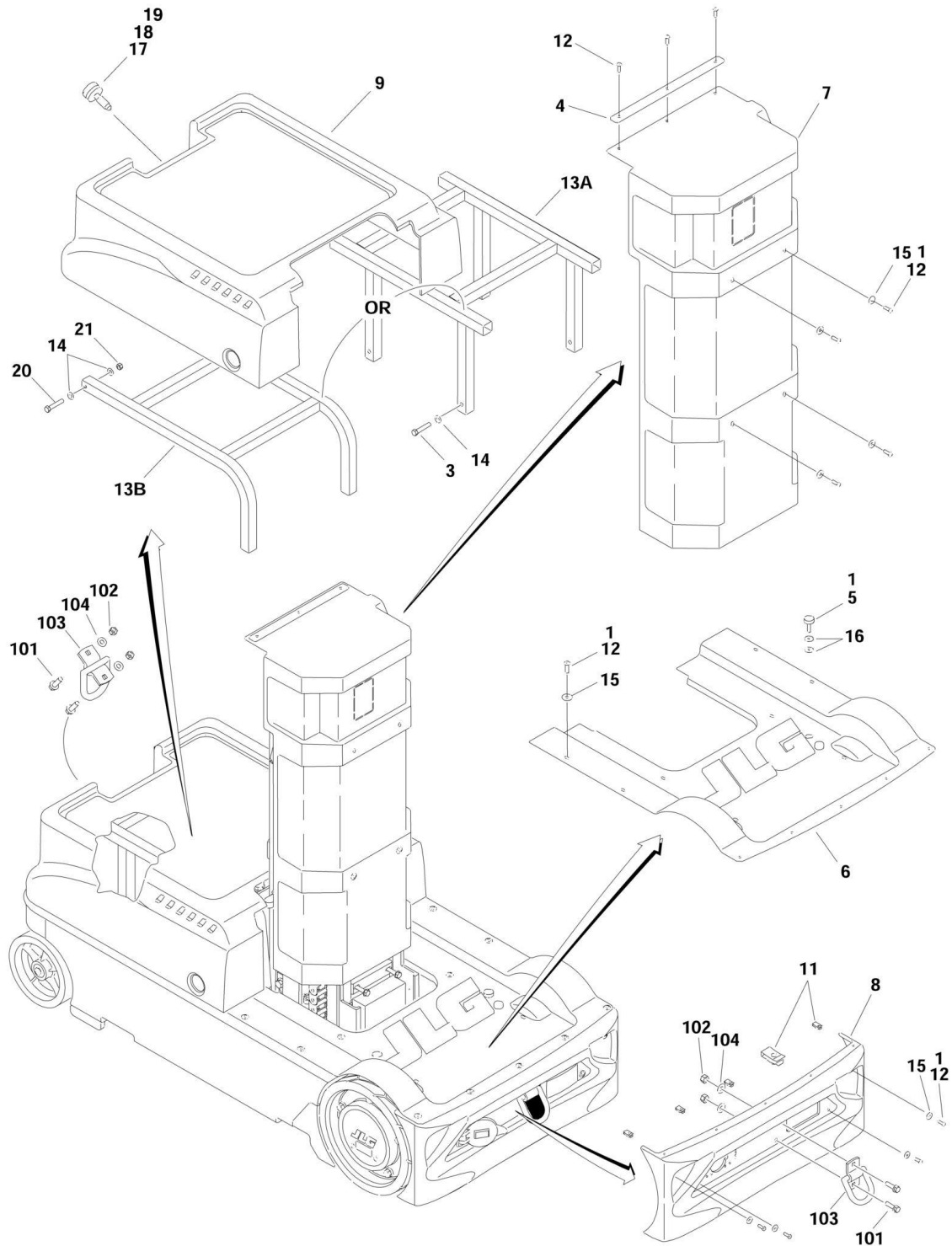

FIGURE 1-2. DRIVE ASSEMBLY

ITEM	PART NUMBER	QTY	DESCRIPTION	REV
	3160323	Ref	DRIVE ASSEMBLY	B
		Ref	Spindle/Hub Assembly	
1	See Note	NSS	Spindle (Note: Use p/n 3160323)	
2	See Note	NSS	Hub (Note: Use Item 205)	
3	See Note	NSS	Ring, Input (Note: Use Item 203)	
4	See Note	NSS	Gear, Input Sun (Note: Use Item 202)	
5	See Note	NSS	Gear, Input Planet (Note: Use Item 202)	
6	See Note	NSS	Pin, Input Planet (Note: Use Item 202)	
7	See Note	NSS	Carrier (Note: Use Item 202)	
8	See Note	NSS	Gear, Output Sun (Note: Use Item 202)	
9	See Note	NSS	Gear, Output Planet (Note: Use Item 206)	
10	See Note	NSS	Pin, Output Planet (Note: Use Item 206)	
11	7024747	1	Cover	
14	See Note	NSS	Bearing (Note: Use Items 201, 203, 205 & 206)	
15	See Note	NSS	Bearing (Note: Use Item 206)	
16	See Note	NSS	Seal, Lip (Note: Use Items 201 & 205)	
17	70000215	1	Seal, Lip	
18	See Note	NSS	Ring, Retaining (Note : Use Item 202)	
19	See Note	NSS	Ring, Retaining (Note: Use Item 200)	
20	70000191	1	O-Ring	
21	See Note	NSS	Thrustwasher (Note: Use Item 200)	
23	See Note	NSS	Plate, Thrust (Note: Use Item 202)	
24	See Note	NSS	Ring, Retaining (Note: Use Item 202)	
25	See Note	6	Thrustwasher (Note: Use Items 202 & 206)	
26	See Note	3	Bushing, Planet (Note: Use Items 202 & 206)	
27	See Note	1	Ring, Retaining (Note: Use Items 203 & 205)	
29	See Note	NSS	Plug (Note: Use Item 200)	
32	See Note	NSS	Thrustwasher, Tanged (Note: Use Item 206)	
		Ref	Drive Assembly	
	See Note	NSS	Hub/Spindle Assembly (Note: Purchase Individual Components) (Includes Items 1-32)	
102	See Note	NSS	Electric Motor Assembly (Note: Use Item 204)	
102A	See Note	NSS	Brush (Note: Use Item 207)	
102B	See Note	NSS	Indicator, Wear (Not Shown) (Note: Use Item 207)	
102C	See Note	NSS	Spring, Brush (Note: Use Item 207)	
102D	See Note	NSS	Bearing (Not Shown) (Note: Use Item 207)	
103	See Note	NSS	Brake Assembly (Note: Use Item 208)	
103A	See Note	NSS	Disc, Brake (Part of Kit) (Note: Use Item 208)	
106	See Note	NSS	Bolt (Note: Use Item 204)	
107	See Note	NSS	Bolt (Note: Use Item 208)	
		Ref	Repair Kit Options:	
200	7024747	1	Cover Kit (Includes Items 11, 19-21 & 29)	
201	7024748	1	Main Seal and Bearing Kit (Includes Items 14, 16 & 20)	
202	70000210	1	Input Carrier Kit (Includes Items 4-8, 18, 20 & 23-26)	
203	7024758	1	Input Ring Kit (Includes Items 3, 14, 20 & 27)	
204	70000211	1	Motor Kit (Includes Items 17, 102 & 106)	
205	7024756	1	Hub Kit (Includes Items 2, 14, 16, 20 & 27)	
206	70000212	1	Output Planet Kit (Includes Items 9, 10, 14, 15, 20, 25, 26 & 32)	
207	70000213	1	Brush and Bearing Kit (Includes Items 102A-102D)	
208	70000214	1	Brake Kit (Includes Items 103, 103A & 107)	

SECTION 1 - BASE

FIGURE 1-3. COVERS AND TIE-DOWNS INSTALLATION (Prior to SN 0130022207)



SECTION 1 - BASE

FIGURE 1-3. COVERS AND TIE-DOWNS INSTALLATION (Prior to SN 0130022207)

ITEM	PART NUMBER	QTY	DESCRIPTION	REV
	0274901	Ref	COVER INSTALLATION (Prior to SN 0130022207)	D
1	0100011	AR	Locking Compound	
3	0641617	4	Bolt 3/8in-16NC x 2in (Prior to SN 0130015319)	
4	0903222	1	Brace	
5	0940049	2	Stopper, Hood	
6		Ref	Cover, Battery and Frame Options:	
6	1671141	NLA	Cover, Battery and Frame (Use p/n 1001120531) (Prior to SN 0130015319)	
6	1001120531	1	Cover, Battery and Frame (SN 0130015319 through 0130022207)	
7	1671143	1	Cover, Mast	
8	1671146	1	Cover, Rear Bumper	
9	1671298	1	Cover, Front Hood	
11	3300454	9	Nut 1/4in-20NC	
12	3900258	22	Screw Button Head 1/4in-20NC x 3/4in	
13		Ref	Support Options:	
13A	4341067	1	Support (Prior to SN 0130015319)	
13B	1001121648	1	Support (SN 0130015319 through 0130022207)	
14	4711600	4	Flatwasher 3/8in Narrow	
15	4751400	19	Flatwasher 1/4in (Wide)	
16	4751500	4	Flatwasher 5/16in (Wide)	
17	1380169	1	Clip	
18	3900174	1	Screw, Thumb	
19	3760308	1	Retainer	
20	0641617	2	Bolt 3/8in-16NC x 2-1/8in (SN 0130015319 through 0130022207)	
21	3311605	2	Locknut 3/8in-16NC (SN 0130015319 through 0130022207)	
	0240114	Ref	TIE-DOWNS INSTALLATION	A
101	0811610	4	Screw 3/8in-16NC x 1-1/4in	
102	3311605	4	Locknut 3/8in-16NC	
103	3760365	2	Tie-Ring	
104	4711600	4	Flatwasher 3/8in Narrow	

SECTION 1 - BASE

FIGURE 1-4. COVERS AND TIE-DOWNS INSTALLATION (SN 0130022207 through 0130032506)

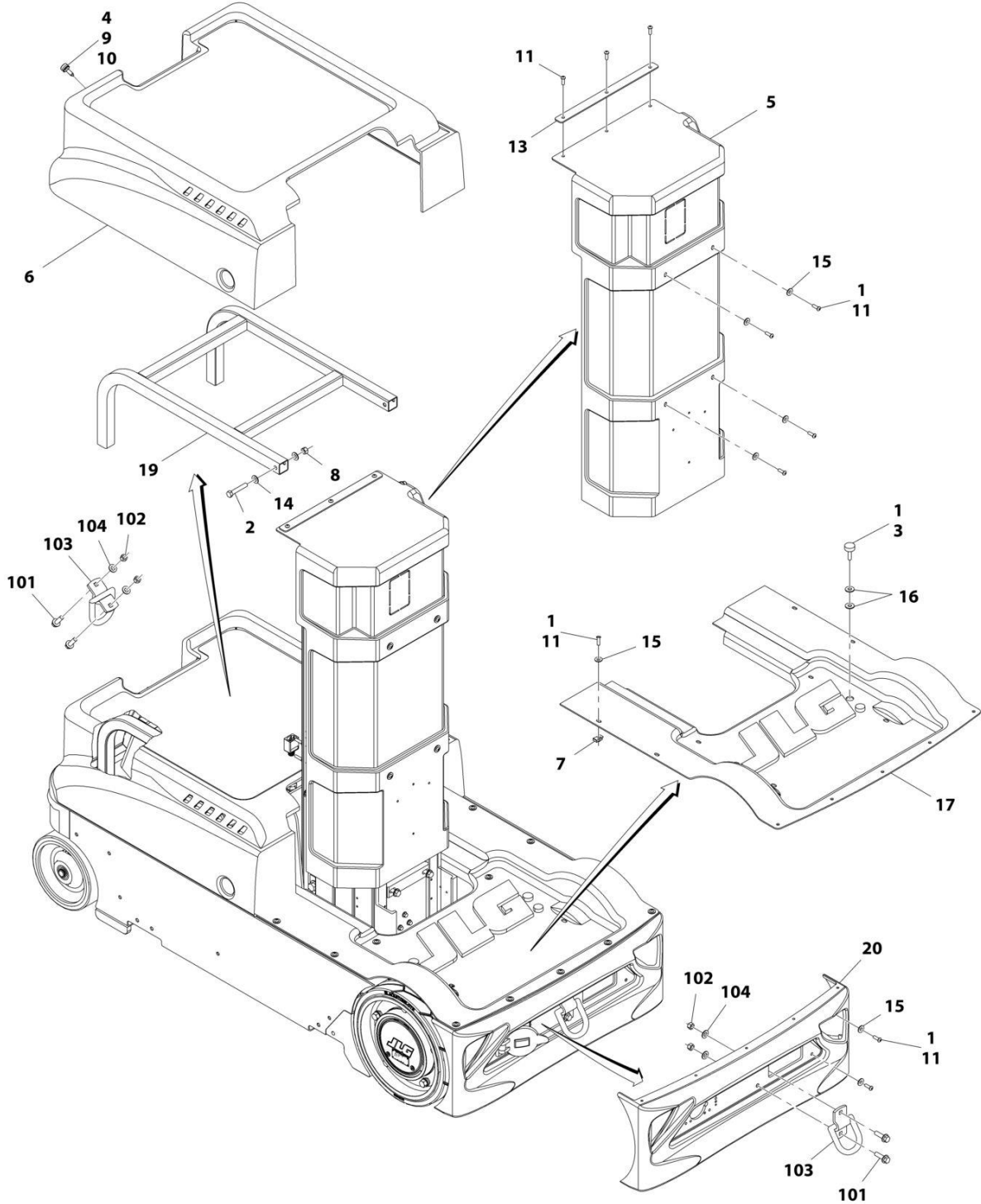

ART_1001171858-D

SECTION 1 - BASE

FIGURE 1-4. COVERS AND TIE-DOWNS INSTALLATION (SN 0130022207 through 0130032506)

ITEM	PART NUMBER	QTY	DESCRIPTION	REV
	1001171858	Ref	COVER INSTALLATION (SN 0130022207 through 0130032506)	E
1	0100011	AR	Locking Compound	
2	0641617	2	Bolt, 3/8 x 2-1/8	
3	0940049	2	Stopper, Hood	
4	1380169	1	Clip	
5	1671143	1	Cover, Mast	
6	1671298	1	Cover, Front Hood	
7	3300454	9	Nut 1/4in-20NC	
8	3311605	2	Locknut 3/8in-16NC	
9	3760308	1	Retainer	
10	3900174	1	Screw, Thumb	
11	3900258	22	Screw, Button Head 1/4in-20NC x 3/4in	
13	0903222	1	Brace	
14	4711600	4	Flatwasher 3/8in Narrow	
15	4751400	19	Flatwasher 1/4in Wide	
16	4751500	4	Flatwasher 5/16in (Wide)	
17	1001120531	1	Cover, Battery and Frame	
19	1001121648	1	Support	
20	1671146	1	Cover, Rear Bumper	
	0240114	Ref	TIE-DOWNS INSTALLATION	A
101	0811610	4	Screw 3/8in-16NC x 1-1/4in	
102	3311605	4	Locknut 3/8in-16NC	
103	3760365	2	Tie-Ring	
104	4711600	4	Flatwasher 3/8in Narrow	

SECTION 2 - CONTROLS

SECTION 2 - CONTROLS

FIGURE 2-1. PUMP MOTOR ASSEMBLY AND INSTALLATION

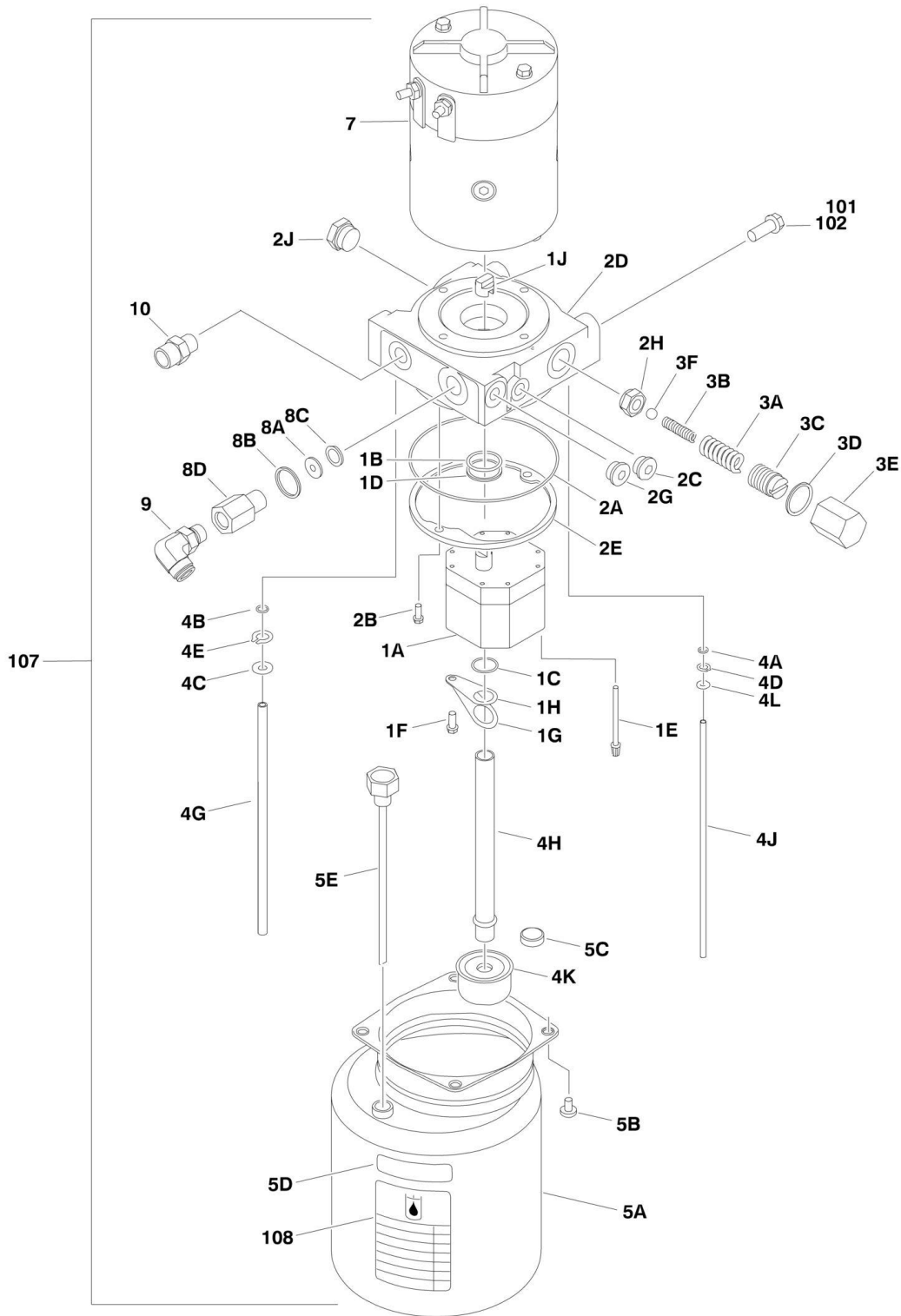

SECTION 2 - CONTROLS

FIGURE 2-1. PUMP MOTOR ASSEMBLY AND INSTALLATION

ITEM	PART NUMBER	QTY	DESCRIPTION	REV
	3600392	1	PUMP/MOTOR ASSEMBLY	D
1	7027943	Ref	Pump Components Kit	
1A	See Note	NSS	Pump (Note: Use Item 1)	
1B	7027943	1	Seal	
1C	7011021	1	Seal	
1D	See Note	NSS	Seal (Note: Use Item 1)	
1E	7010928	4	Screw	
1F	7011033	1	Screw	
1G	See Note	NSS	Lockwasher (Note: Use Item 1)	
1H	See Note	NSS	Retainer (Note: Use Item 1)	
1J	7011016	1	Coupler	
2	7027944	Ref	Adaptor Components Kit	
2A	7011025	1	Seal	
2B	7011011	2	Screw	
2C	See Note	NSS	Plug (Note: Use Item 2)	
2D	See Note	NSS	Adaptor (Note: Use Item 2)	
2E	7011013	1	Retainer	
2F	See Note	NSS	Plug, Plastic (Not Shown) (Note: Use Item 2)	
2G	See Note	NSS	Plug, Steel (Note: Use Item 2)	
2H	See Note	NSS	Seat Assembly (Note: Use item 2)	
2J	See Note	NSS	Plug (Note: Use Item 2)	
3	7027945	Ref	Relief Valve Components Kit	
3A	7011008	1	Spring	
3B	7011017	1	Spring	
3C	7011009	1	Screw, Adjustment	
3D	See Note	NSS	Gasket (Note: Use Item 3)	
3E	7011004	1	Cap	
3F	See Note	NSS	Ball (Note: Use Item 3)	
4	7027946	Ref	Tube Components Kit	
4A	7011024	1	Seal	
4B	See Note	NSS	Seal (Note: Use Item 4)	
4C	See Note	NSS	Washer (Note: Use Item 4)	
4D	7011031	1	Ring, Retaining	
4E	7011032	1	Ring, Retaining	
4G	See Note	NSS	Tube (Note: Use Item 4)	
4H	See Note	NSS	Tube (Note: Use Item 4)	
4J	See Note	NSS	Tube (Note: Use Item 4)	
4K	7011029	1	Strainer	
4L	7011034	1	Spacer	
5	7027947	Ref	Tank Components Kit	
5A	See Note	NSS	Tank (Note: Use Item 5)	
5B	See Note	NSS	Screw (Note: Use Item 5)	
5C	7011027	1	Magnet	
5D	See Note	NSS	Label (Note: Use Item 5)	
5E	7011069	1	Breather/Dipstick	
6	See Note	1	Label (Not Shown) (Note: Not Available for Purchase)	
7	7027948	1	Motor Assembly	
7	See Note	NSS	Brush Kit (Note: Use Item 7)	
8	7027949	Ref	Return Port Components Kit	
8A	See Note	NSS	Seal (Note: Use Item 8)	

SECTION 2 - CONTROLS

ITEM	PART NUMBER	QTY	DESCRIPTION	REV
8B	See Note	NSS	Seal (Note: Use Item 8)	
8C	See Note	NSS	Washer (Note: Use Item 8)	
8D	See Note	NSS	Body, Return Port (Note: Use Item 8)	
9	2221185	1	Fitting, 90	
10	2110606	1	Fitting, Straight	
		Ref	PUMP/MOTOR INSTALLATIONS	
	0273546	Ref	Standard Hydraulic Oil	E
	0274181	Ref	Fire Resistant Hydraulic Oil	A
101	0100011		Locking Compound	
102	0641606		Bolt 3/8in-16NC x 3/4in	
107	3600392	1	Pump/Motor Assembly (See Items 1-10 for Breakdown)	
108	1704412	1	Decal - Hydraulic Oil (Stamp Appropriately)	
109		Ref	Oil, Hydraulic Options (Not Shown):	
109	2300021	1.2 gals	Standard Hydraulic Oil	
109	2300014	1.2 gals	Fire Resistant Hydraulic Oil	

SECTION 2 - CONTROLS

FIGURE 2-2. BATTERY CHARGER AND PLUG INSTALLATION (Prior to SN 0130010886)

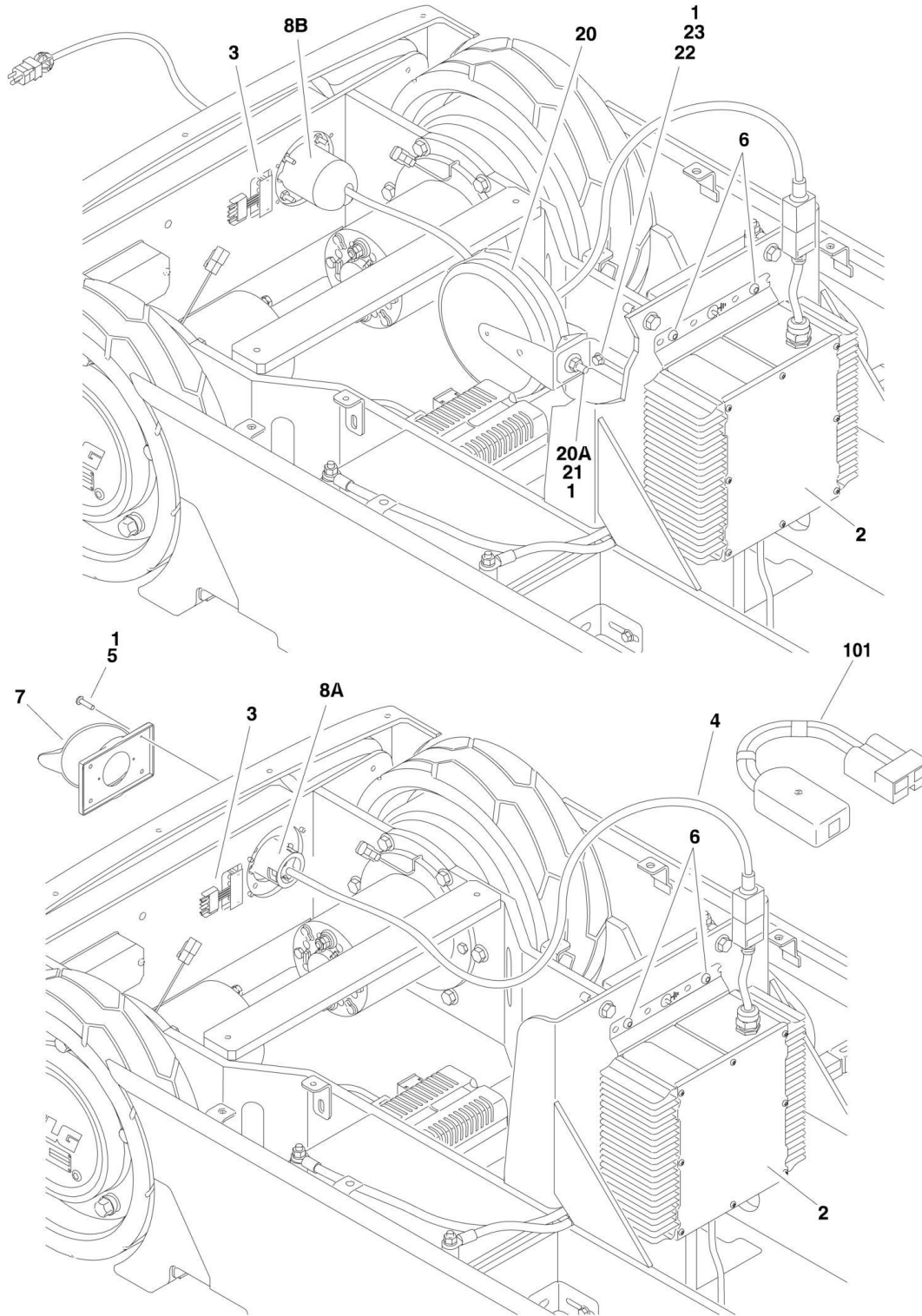

SECTION 2 - CONTROLS

FIGURE 2-2. BATTERY CHARGER AND PLUG INSTALLATION (Prior to SN 0130010886)

ITEM	PART NUMBER	QTY	DESCRIPTION	REV
		Ref	BATTERY CHARGER INSTALLATIONS	
	0274897	Ref	ANSI - Charger with Plug	C
	0274898	Ref	Australian - Charger without Plug	B
	0274899	Ref	ANSI - Charger without Plug	C
	0274900	Ref	ANSI - Charger with Plug/Cord Reel	C
1	0100011	AR	Locking Compound	
2	0400241	1	Battery Charger Assembly (No Serviceable Parts Available)	
3	0610131	1	LED Board	
4	1060689	1	Cord, Electrical	
5	3911016	4	Screw #10-24NC x 1in	
5	3311001	2	Nut #10-24NC (Charger with Australian Plug Only)	
6	4191706	4	Screw 6mm x 12mm	
7		Ref	Cover, Terminal Options:	
7	4460802	1	Charger with Plug	
7	4460802	1	Charger without Plug	
7	Not Required	0	Charger with Plug/Cord Reel	
8		Ref	Terminal, Inlet Options:	
8A	4460803	1	Charger with ANSI Plug	
8A	4460940	1	Charger with Australian Plug	
8A	Not Required	0	Charger without Plug	
8B	4120046	1	Socket, Cord Reel Stop (Charger with ANSI Plug/Cord Reel Only)	
		Ref	Note: Items 20-23 used with Charger with Plug/Cord Reel only.	
20	3680057	1	Reel, Charger Cord	
20A	0791508	1	Screw 5/16in-18NC x 1in	
21	4751500	1	Flatwasher 5/16in Wide	
22	0791406	1	Screw 1/4in-20NC x 3/4in	
23	3575423	1	Angle, Mounting	
101	1600466	1	BATTERY CHARGER REPROGRAM CONTROLLER KIT (Use p/n 2915230)	

SECTION 2 - CONTROLS

FIGURE 2-3. BATTERY CHARGER AND PLUG INSTALLATION (SN 0130010886 through 0130032506)

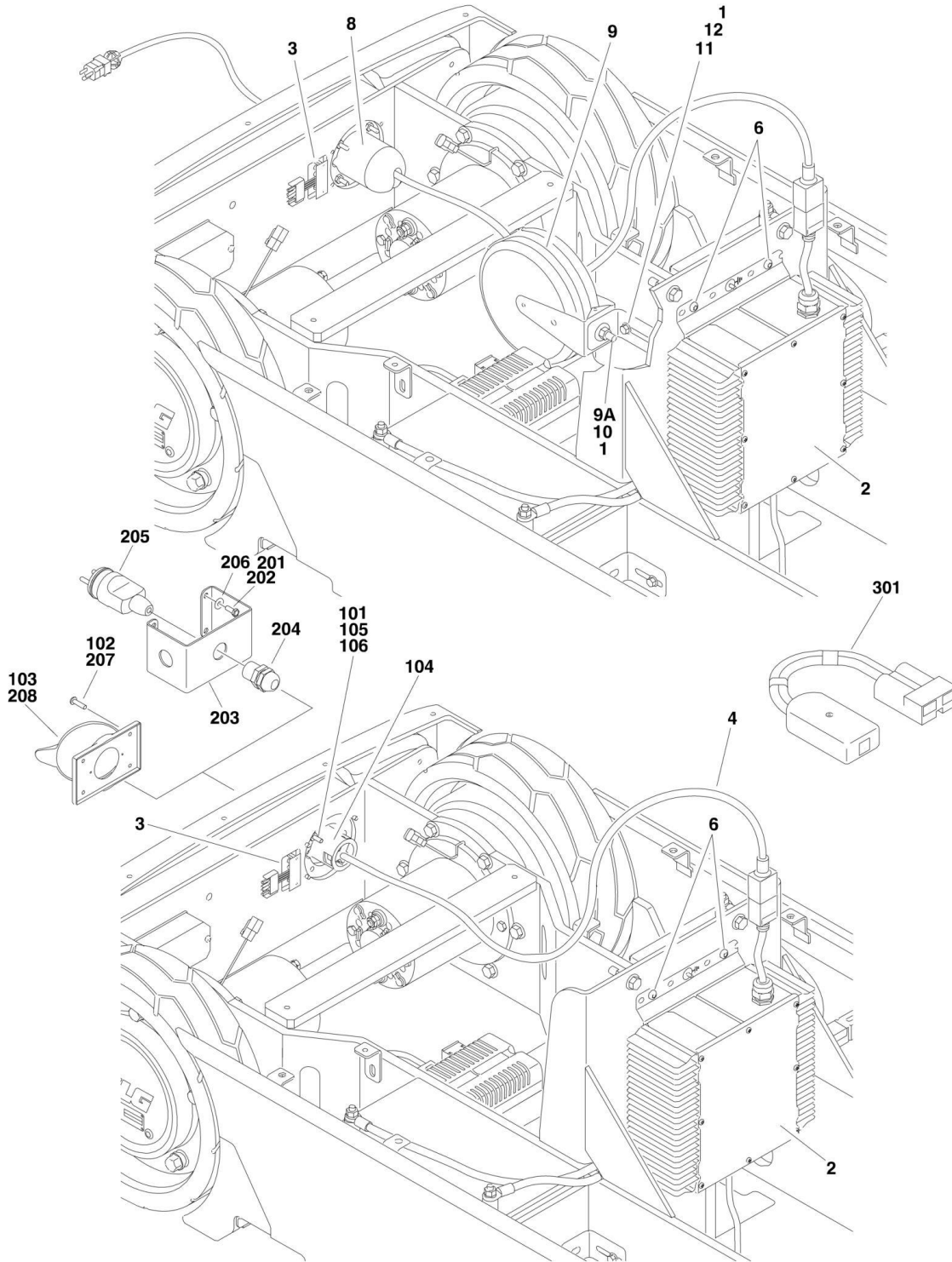

SECTION 2 - CONTROLS

FIGURE 2-3. BATTERY CHARGER AND PLUG INSTALLATION (SN 0130010886 through 0130032506)

ITEM	PART NUMBER	QTY	DESCRIPTION	REV
		Ref	BATTERY CHARGER INSTALLATIONS	
	0274898	Ref	ANSI/ANSI Export - Charger without Plug	F
	0274900	Ref	ANSI - Charger with Plug/Cord Reel	F
1	0100011	AR	Locking Compound	
2		Ref	Battery Charger Assembly Options (No Serviceable Parts Available):	
2	0400241	NLA	Battery Charger Assembly (Use p/n 1001110117) (SN 0130010886 through 0130013544)	
2	1001102932	1	Battery Charger Assembly (SN 0130013545 through 0130016979)	
2	1001136381	1	Battery Charger Assembly (SN 0130016980 through 0130032506)	
3	0610131	1	LED Board	
4	1060689	1	Cord, Electrical	
6	4191706	4	Screw 6mm x 12mm	
8	4120046	1	Terminal, Inlet Socket, Cord Reel Stop (Charger with ANSI Plug/Cord Reel Only)	
		Ref	Note: Items 9-12 used with Charger with Plug/Cord Reel only.	
9	3680057	1	Reel, Charger Cord	
9A	0791508	1	Screw 5/16in-18NC x 1in	
10	4751500	1	Flatwasher 5/16in Wide	
11	0791406	1	Screw 1/4in-20NC x 3/4in	
12	3575423	1	Angle, Mounting	
		Ref	CHARGER PLUG INSTALLATIONS (ANSI/ ANSI EXPORT/ AUSTRALIAN SPECS)	
	1001097449	Ref	Charger Plug 110V (ANSI/ ANSI Export/ CSA/ Japanese Spec)	B
	1001097455	Ref	Charger Plug 220V (Australian Spec)	C
	1001097456	Ref	Charger Plug No Plug (ANSI Export Spec)	A
101	0100011	AR	Locking Compound	
102	3911016	AR	Screw #10-24NC x 1in	
103	4460802	1	Cover, Terminal	
104		Ref	Terminal, Inlet Options:	
104	4460803	1	1001097449 Installation	
104	4460940	1	1001097455 Installation	
104	Not Required	0	1001097456 Installation	
105	3311001	2	Nut #10-24NC (1001097455 Installation Only)	
106	4761000	2	Lockwasher #10 (1001097455 Installation Only)	
		Ref	CHARGER PLUG INSTALLATIONS (CE SPECS ONLY)	
	1001097450	Ref	Charger Plug 220V Post Ground	B
	1001097451	Ref	Charger Plug 220V Side Ground	B
	1001097452	Ref	Charger Plug 220V Keyed Ground	B
	1001097453	Ref	Charger Plug 110V IEC 60309 Yellow	B
	1001097454	Ref	Charger Plug 110V IEC 60309 Blue	B
	1001097456	Ref	Charger Plug No Plug	A
201	0100011	AR	Locking Compound	
202	0721004	4	Screw #10-24NC x 1/2in	
203	3571584	1	Plate, Plug Inlet	
204	4460428	1	Connector, Strain Relief	
205		Ref	Terminal, Male Options:	
205	4461202	1	1001097450 Installation	

SECTION 2 - CONTROLS

ITEM	PART NUMBER	QTY	DESCRIPTION	REV
205	4461205	1	1001097451 Installation	
205	4461249	1	1001097452 Installation	
205	4461196	1	1001097453 Installation	
205	4461199	1	1001097454 Installation	
205	Not Required	0	1001097456 Installation	
206	4711000	4	Flatwasher #10	
207	3911016	AR	Screw #10-24NC x 1in (1001097456 Installation Only)	
208	4460802	1	Cover, Terminal (1001097456 Installation Only)	
301	1600466	1	BATTERY CHARGER REPROGRAM CONTROLLER KIT (Use p/n 2915230)	

SECTION 2 - CONTROLS

FIGURE 2-4. BATTERIES, SWITCHES, HORN AND BEACON LIGHT INSTALLATION

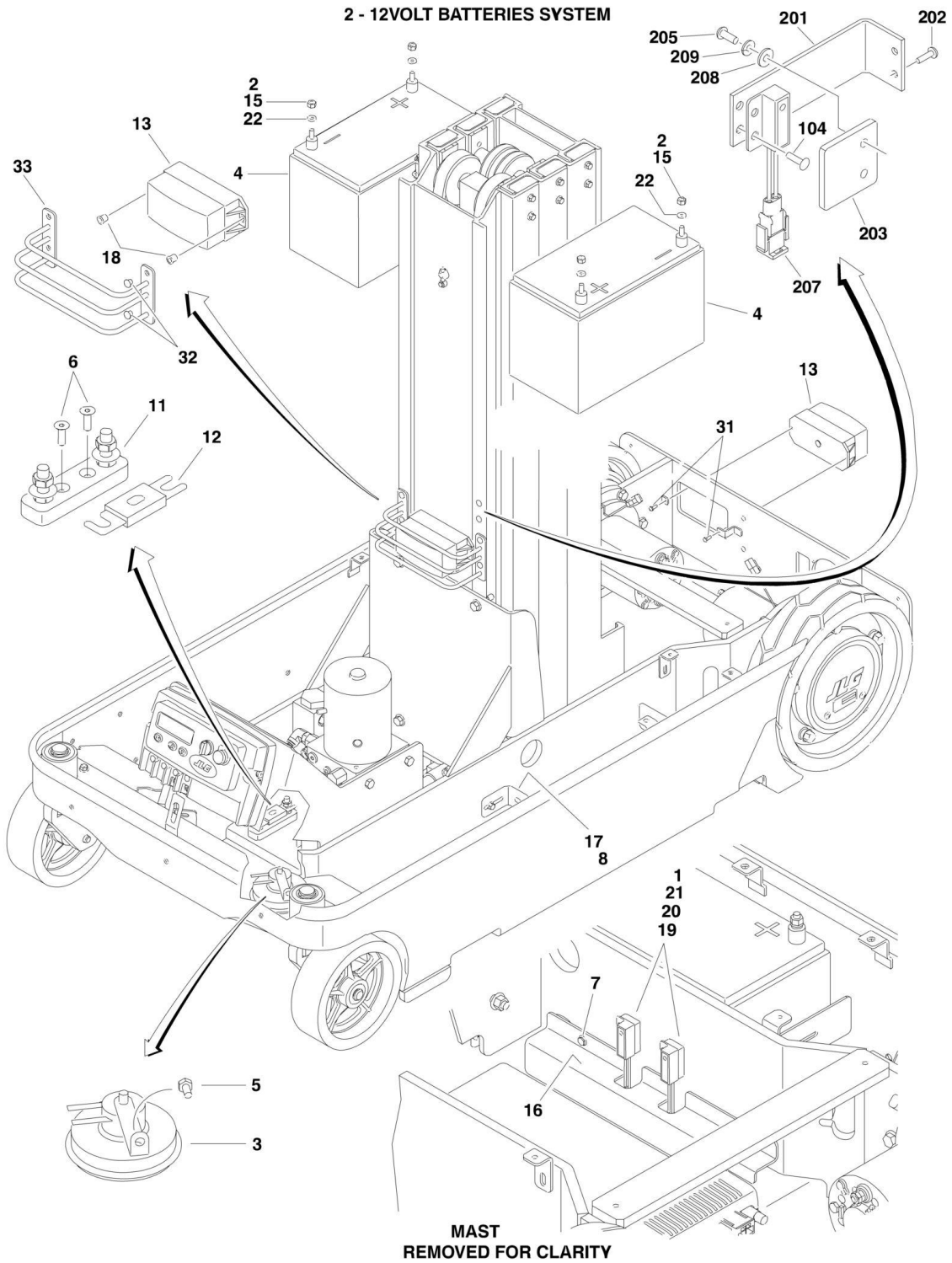

SECTION 2 - CONTROLS

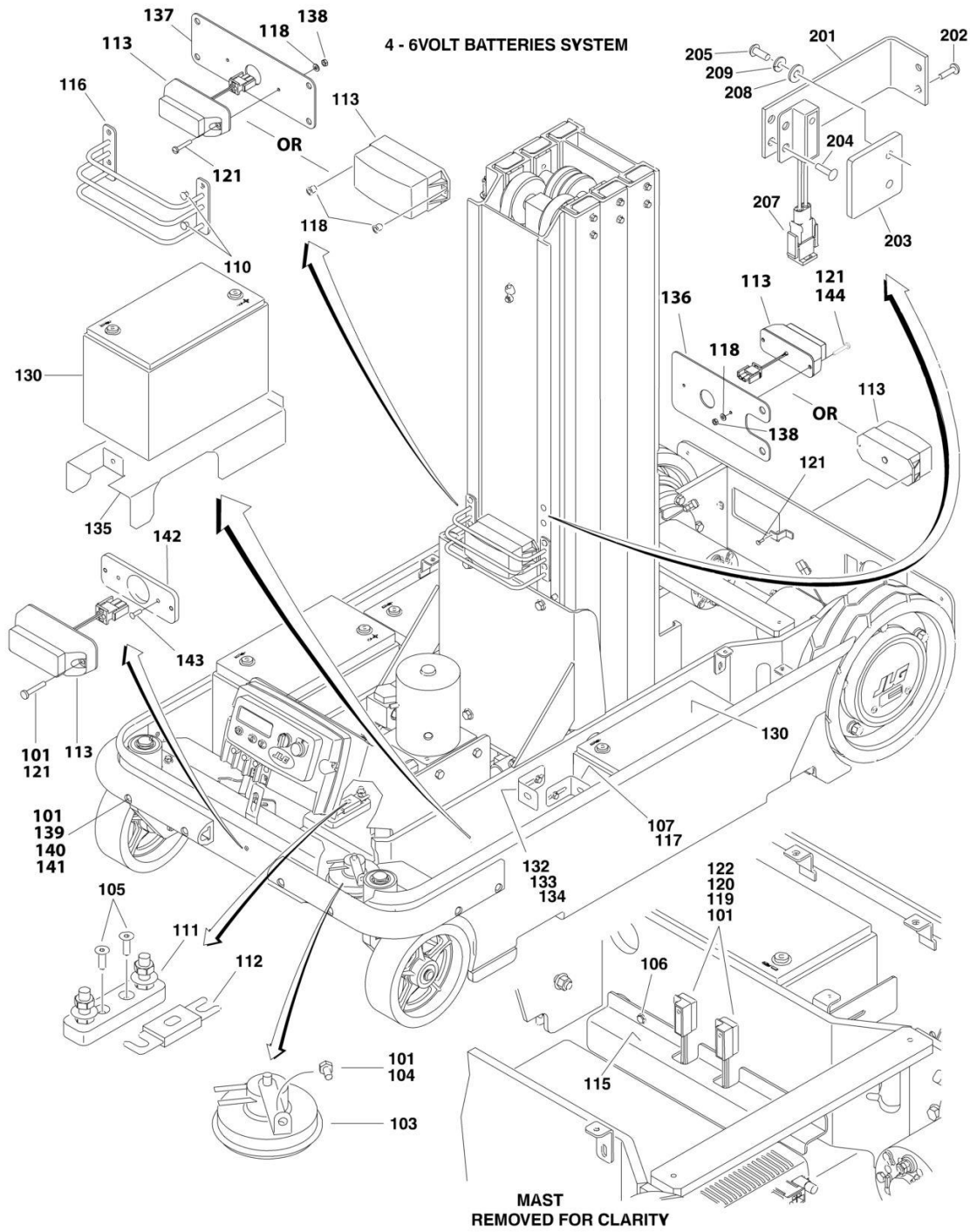

SECTION 2 - CONTROLS

FIGURE 2-4. BATTERIES, SWITCHES, HORN AND BEACON LIGHT INSTALLATION

ITEM	PART NUMBER	QTY	DESCRIPTION	REV
		Ref	Note: To modify machine from (2) 12V batteries to (4) 6V batteries, use kit p/n 1001127560.	
	0274896	Ref	BATTERIES AND ALARM INSTALLATION (2 - 12VOLT BATTERIES SYSTEM)	F
1	0100011	AR	Locking Compound	
2	0100051	AR	Grease, Battery Terminal	
3	0140022	1	Horn	
4		Ref	Battery Options:	
4	0400209	2	12Volt (Prior to SN 0130016980)	
4	1001136380	2	12Volt (SN 0130016980 through 0130032506)	
5	0641404	1	Bolt 1/4in-20NC x 1/2in	
6	0741005	2	Capscrew, Flat Head #10-24NC x 1/2in	
7	0791003	2	Screw #10-24NC x 3/8in	
8	0791406	2	Screw 1/4in-20NC x 3/4in	
11	2400044	1	Block, Fuse Mounting	
12	2400069	1	Fuse 175Amp	
13	2920178	2	Light, Strobe	C
13	7027733	2	Bulb, Replacement (1 Per Assembly)	
15	3311501	4	Nut 5/16in-18NC	
16	3380541	1	Shield, Wire	
17	3575423	2	Plate, Battery Hold-down	
18	3820032	2	Rivet	
19	3911016	4	Screw #10-24NC x 1in	
20	4071084	2	Shim	
21	4360514	2	Switch, Proximity	
22	4761500	4	Lockwasher 5/16in	
31	4191406	2	Screw 4mm x 12mm	
32	2080040	4	Huck Fastener (SN 0130010454 through 0130032506)	
33	3380771	1	Shield, Strobe Light (SN 0130010454 through 0130032506)	
	1001120444	Ref	BATTERIES AND ALARM INSTALLATION (4 - 6VOLT BATTERIES SYSTEM)	I
101	0100011	AR	Locking Compound	
102	0100051	AR	Grease, Battery Terminal	
103	0140022	1	Horn	
104	0641404	1	Bolt 1/4in-20NC x 1/2in	
105	0741005	2	Capscrew, Flat Head #10-24NC x 1/2in	
106	0791003	2	Screw #10-24NC x 3/8in	
107	0791406	2	Screw 1/4in-20NC x 3/4in (Prior to SN 0130016983)	
110	2080040	4	Huck Fastener (SN 0130010454 through 0130027450)	
111	2400044	1	Block, Fuse Mounting	
112	2400069	1	Fuse 175Amp	
113	2920178	2	Light, Strobe (Prior to SN 0130023241)	C
113	7027733	2	Bulb, Replacement (1 Per Assembly) (Prior to SN 0130023241)	
113	1001187862	2	Light, Strobe (SN 0130023241 through 0130032506)	
115	3380541	1	Shield, Wire	
116	3380771	1	Shield, Strobe Light (SN 0130010454 through 0130027450)	
117	3575423	4	Plate, Battery Hold-down (Prior to SN 0130016983)	
118	3820032	2	Rivet (Prior to SN 0130023241)	
118	4811400	AR	Washer, M4 (SN 0130023241 through 0130032506)	
119	3911016	4	Screw #10-24NC x 1in	

SECTION 2 - CONTROLS

ITEM	PART NUMBER	QTY	DESCRIPTION	REV
120	4071084	2	Shim	
121	4191406	2	Screw 4mm x 12mm (Prior to SN 0130023241)	
121	4010412	AR	Screw, M4 x 24 (SN 0130023241 through 0130032506)	
122	4360514	2	Switch, Proximity	
130	1001120445	4	Battery (Prior to SN 0130021959)	
130	1001177558	4	Battery (SN 0130021959 through 0130032506)	
132	0641408	2	Bolt 1/4in-20NC x 1in (SN 0130015906 through 0130016983)	
133	3311405	2	Locknut 1/4in-20NC (SN 0130015906 through 0130016983)	
134	4711400	4	Flatwasher 1/4in Narrow (SN 0130015906 through 0130016983)	
135	1001129506	2	Plate, Battery Support (Use p/n 1001133303)	
136	1001187868	1	Plate, Mount (SN 0130023241 through 0130027450)	
137	1001187869	1	Plate, Mount (SN 0130023241 through 0130027450)	
138	3290401	AR	Nut, M4 (SN 0130023241 through 0130032506)	
139	4751400	10	Flatwasher 1/4in Wide (SN 0130027450 through 0130032506)	
140	0641408	8	Bolt 1/4in-20NC x 1in (SN 0130027450 through 0130032506)	
141	3311405	8	Locknut 1/4in-20NC (SN 0130027450 through 0130032506)	
142	1001207630	1	Plate, Mounting (SN 0130027450 through 0130032506)	
143	3820013	2	Rivet (SN 0130027450 through 0130032506)	
144	4010414	2	Screw M4 x 30 (SN 0130027450 through 0130032506)	
	0275901	Ref	7FT LIMITER SWITCH INSTALLATION (OPTIONAL)	A
201	0903671	1	Bracket	
202	2080040	2	Fastener, Huck	
203	3572511	1	Plate	
204	3820024	2	Rivet	
205	3900205	2	Screw #10-24NC x 5/8in	
206	4240033	AR	Tie-Strap (Not Shown)	
207	4360515	1	Switch, Proximity	
208	4750800	2	Flatwasher #8 Wide	
209	4761000	2	Lockwasher #10	

SECTION 2 - CONTROLS

FIGURE 2-5. GROUND COMPONENTS INSTALLATIONS

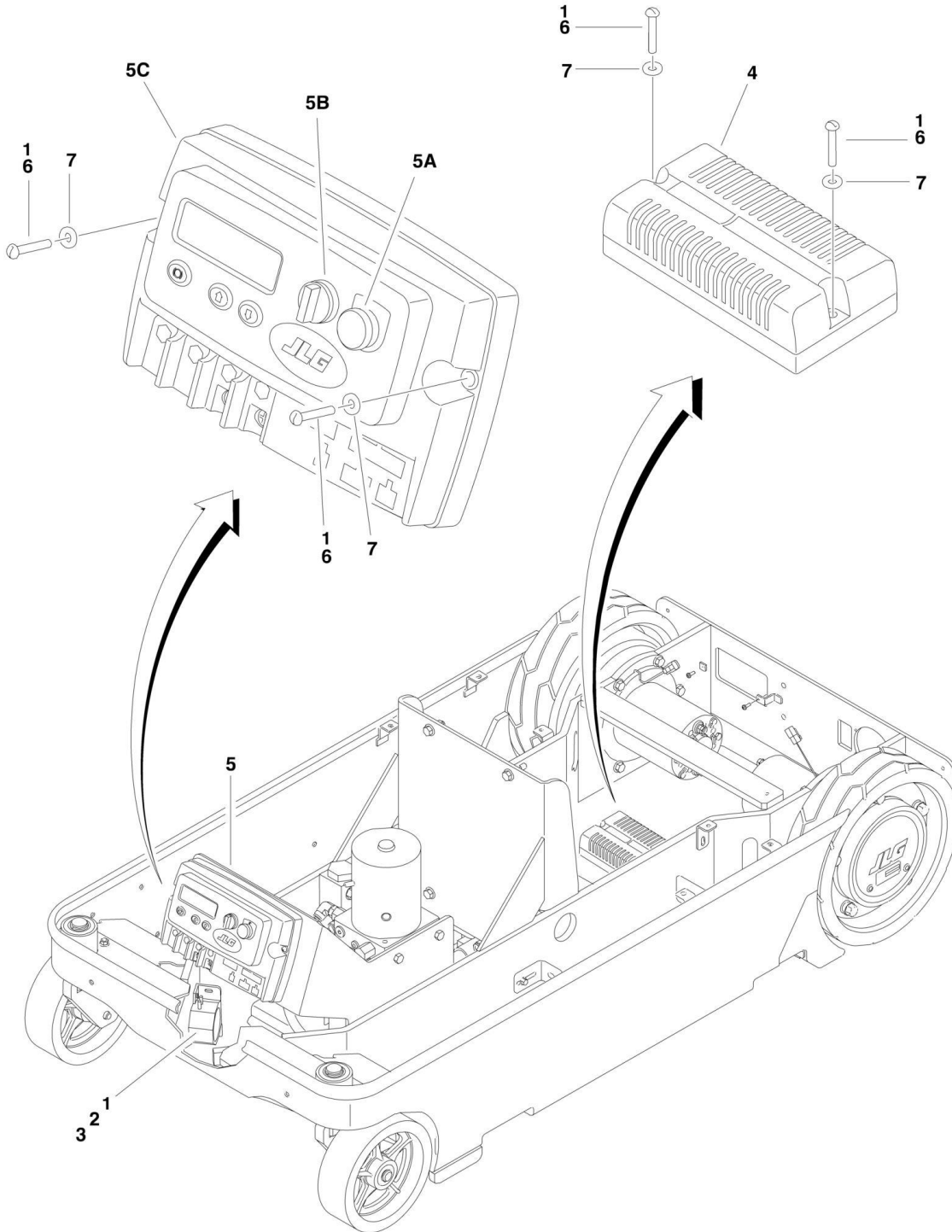

SECTION 2 - CONTROLS

FIGURE 2-5. GROUND COMPONENTS INSTALLATIONS

ITEM	PART NUMBER	QTY	DESCRIPTION	REV
		Ref	GROUND CONTROLS INSTALLATION	
	0274894	Ref	All Specs except Australian/Japanese and Chinese Specs	D
	0274894	Ref	Australian Spec (Prior to SN 0130017845)	D
	1001137013	Ref	Australian Spec (SN 0130017845 through 0130032506)	B
	0274895	Ref	Japanese and Chinese Specs Only	D
1	0100011	AR	Locking Compound	
2	0140033	1	Alarm	
3	0641404	2	Bolt 1/4in-20NC x 1/2in	
4		Ref	Module, Traction Options:	
4	1600397	NLA	Module, Traction (Use p/n 1001102847) (Prior to SN 0130014947)	
4	1600451	NLA	Module, Traction (Use p/n 1001102847) (Prior to SN 0130014947)	
4	1001102847	1	Module, Traction (SN 0130014947 through 0130032506)	
5		Ref	Module, Ground Control Station Options:	
5	1600435	1	All Specs except Australian/Japanese and Chinese Specs	
5	1600435	1	Australian Spec (Prior to SN 0130017845)	
5	1001136954	1	Australian Spec (SN 0130017845 through 0130032506)	
5	1600436	1	Japanese and Chinese Specs Only	
5A	7024428	1	Emergency Stop Switch Assy	
5B		Ref	Selector Switch Assy Options:	
5B	7024430	1	All Specs (Australian Spec) (Prior to SN 0130017845)	
5B	7024591	1	Australian Spec (SN 0130017845 through 0130032506)	
5C		Ref	Cover Assy Options:	
5C	7024460	1	All Specs (Australian Spec) (Prior to SN 0130017845)	
5C	7024592	1	Australian Spec (SN 0130017845 through 0130032506)	
6	3911020	4	Screw #10-24NC x 1-1/4in	
7	4751000	4	Flatwasher #10	

SECTION 2 - CONTROLS

FIGURE 2-6. PLATFORM CABLES AND CONTROLS INSTALLATION

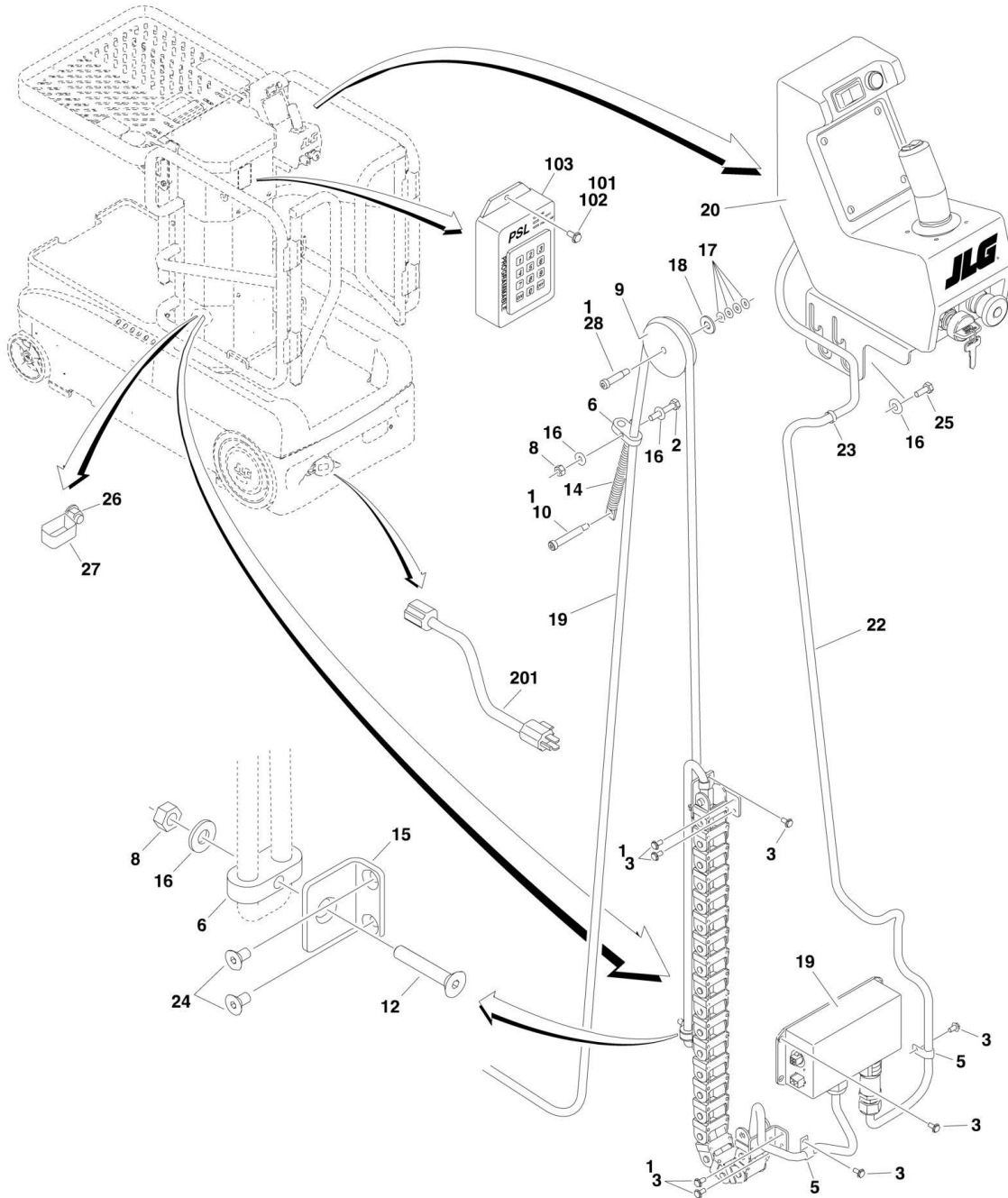

SECTION 2 - CONTROLS

FIGURE 2-6. PLATFORM CABLES AND CONTROLS INSTALLATION

ITEM	PART NUMBER	QTY	DESCRIPTION	REV
		Ref	PLATFORM CABLES AND CONTROLS INSTALLATIONS	
	0273551	Ref	All Specs Except Australian Spec	O
	0273551	Ref	Australian Spec (Prior to SN 0130017845)	O
	1001137012	Ref	Australian Spec (SN 0130017845 through 0130032506)	C
1	0100011	AR	Locking Compound	
2	0641412	1	Bolt 1/4in-20NC x 1-1/2in	
3	0791003	11	Screw #10-24NC x 3/8in	
5	1320043	3	Clamp (Prior to SN 0130031692)	
5	1320041	3	Clamp (SN 013031692 through 0130032506)	
6	1320149	2	Clamp, Hose	
8	3311405	2	Locknut 1/4in-20NC	
9	3580344	1	Pulley, Control Cable	
10	3900264	1	Screw, Shoulder	
12	0741412	1	Screw, Countersunk 1/4in-20NC x 1-1/2in	
14	4160130	1	Spring, Extension	
15	4340838	1	Support, Cable Mount	
16	4711400	5	Flatwasher 1/4in Narrow	
17	4751000	4	Flatwasher #10 Wide	
18	4751500	1	Flatwasher 5/16in Wide	
19	4923035	1	Harness, Base to Platform (See ELECTRICAL SECTION for Breakdown)	
20		Ref	Platform Control Box Assembly Options (See CONTROL BOX ASSEMBLY for Breakdown):	
20	0861768	NLA	Platform Control Box Assembly (All Specs) (Use p/n 1001098194) (Prior to SN 0130010761)	
20	1001098194	1	Platform Control Box Assembly (All Specs) (SN 0130010761 through 0130032506)	
20	0861768	NLA	Platform Control Box Assembly (Australian Spec) (Use p/n 1001098194) (Prior to SN 0130010761)	
20	1001098194	1	Platform Control Box Assembly (Australian Spec) (SN 0130010761 through 0130017844)	
20	1001137011	1	Platform Control Box Assembly (Australian Spec) (SN 0130017845 through 0130032506)	
22	4923316	1	Harness, Platform Controls (See ELECTRICAL SECTION for Breakdown)	
23	4240018	3	Tie-Strap	
24	0741003	2	Screw, Countersunk #10-24NC x 3/8in	
25	0641406	2	Bolt 1/4in-20NC x 3/4in	
26	3311605		Locknut 3/8in-16NC	
27	1321283	1	Clamp (All Specs Except Australian Spec) (Prior to SN 0130028647)	
27	1001116792	1	Clamp (All Specs Except Australian Spec) (SN 0130028647 through 0130032506)	
27	1321283	1	Clamp (Australian Spec)	
28	3900373	1	Screw, Shoulder	
	0273566	Ref	PROGRAMMABLE SECURITY LOCK INSTALLATION (OPTIONAL)	A
101	0100011	AR	Locking Compound	
102	0721003	2	Screw #10-24NC x 3/8in	
103	2940161	1	Lock, Electronic	
201	4923174	Ref	EXTENSION CORD 110VOLT - 6FT (OPTIONAL)	A

SECTION 2 - CONTROLS

FIGURE 2-7. CONTROL BOX ASSEMBLY

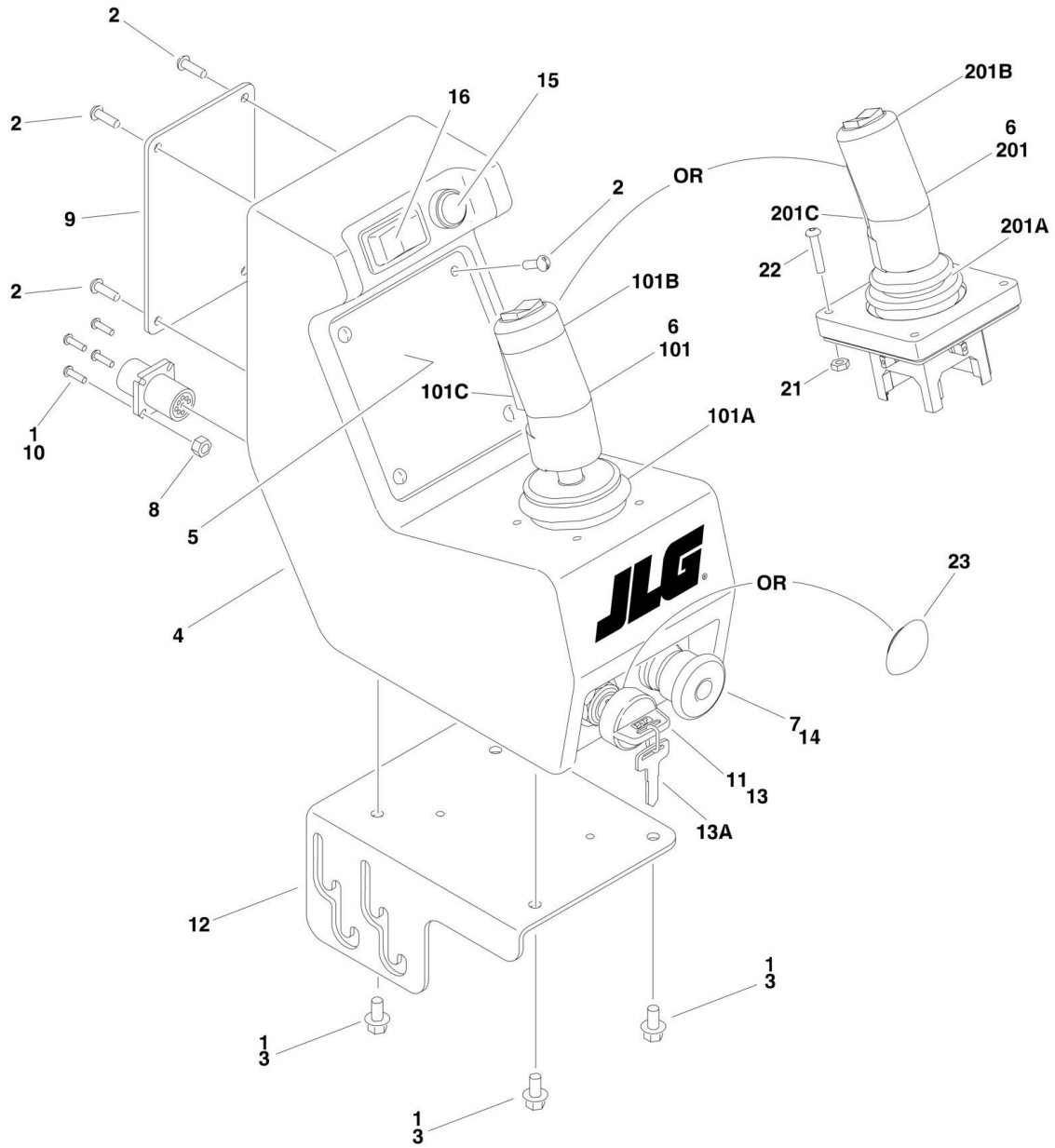

SECTION 2 - CONTROLS

FIGURE 2-7. CONTROL BOX ASSEMBLY

ITEM	PART NUMBER	QTY	DESCRIPTION	REV
		Ref	CONTROL BOX ASSEMBLIES	
	0861768	Ref	Control Box Assemblies (All Specs) (Original Equipment) (Prior to SN 0130010761)	C
	1001098194	Ref	Control Box Assemblies (All Specs) (Service Replacement) (SN 0130010761 through 0130032506)	A
	0861768	Ref	Control Box Assemblies (Australian Spec) (Original Equipment) (Prior to SN 0130010761)	C
	1001098194	Ref	Control Box Assemblies (Australian Spec) (Service Replacement) (SN 0130010761 through 0130017844)	A
	1001137011	Ref	Control Box Assemblies (Australian Spec) (SN 0130017845 through 0130032506)	A
		Ref	Note: Original Equipment Control Box p/n 0861768 may have been replaced with Service Replacement Control Box p/n 1001098194. Identify component before ordering parts.	
1	0100011	AR	Locking Compound	
2	0630464	8	Screw, Button #10-24NC x 1/2in	
3	0791404	4	Screw, Countersunk 1/4in-20NC x 1/2in	
4		Ref	Box, Control Options:	
4	0861767	1	Box, Control (Prior to SN 0130010761)	
4	1001098193	1	Box, Control (SN 0130010761 through 0130032506)	
5	1600378	1	Module, Platform Controller	
5	70003805	1	Decal - Directional Overlay	
6		Ref	Controller Assembly Options:	
6	1600379	NLA	Controller Assembly (Use p/n 1600454) (See Items 101-101C for Breakdown) (Prior to SN 0130010761)	
6	1001098192	1	Controller Assembly (See Items 201-201C for Breakdown) (SN 0130010761 through 0130032506)	
7	1706007	1	Decal - Emergency Stop	
8	3310601	4	Nut #6-32NC	
9	3380540	1	Panel, Control Box	
10	3910608	4	Screw, Machine #6-32NC x 1/2in	
11		Ref	Screw, Machine #8-32NC x 1/4in Options:	
11	3910804	2	All Specs Except Australian Spec	
11	3910804	2	Australian Spec (Prior to SN 0130017845)	
11	Not Required	0	Australian Spec (SN 0130017845 through 0130032506)	
12	4340884	1	Mount, Control Box	
13		Ref	Keypress Assembly Options:	
13	4360467	1	All Specs Except Australian Spec	
13	4360467	1	Australian Spec (Prior to SN 0130017845)	
13	Not Required	0	Australian Spec Only (SN 0130017845 through 0130032506)	
13A	2860030	1 pr	Key, Replacement	
14	4360562	1	Switch, Emergency Stop	
15	4360567	1	Switch, Push Button (Includes Harness)	
16	4360581	1	Switch, Rocker	
21	3311005	4	Locknut #10-24NC (SN 0130010761 through 0130032506)	
22	3900189	4	Screw #10-24NC x 1in (SN 0130010761 through 0130032506)	
23		Ref	Plug, Liquid Tight	
23	Not Required	0	All Specs Except Australian Spec	
23	1001137484	1	Australian Spec Only (SN 0130017845 through 0130032506)	
	1600454	Ref	CONTROLLER ASSEMBLY (Prior to SN 0130010761)	B
101	1600379	1	Controller Assembly (Use p/n 1600454)	
101A	70000682	1	Boot, Rubber (Base of Controller)	

SECTION 2 - CONTROLS

ITEM	PART NUMBER	QTY	DESCRIPTION	REV
101A	7027766	1	Ring, Retaining	
101B	7027764	1	Boot, Rubber (Steer Switch)	
101B	7027365	1	Actuator, Handle	
101B	70000684	2	Screw	
101B	70000686	2	Screw	
101B	70000683	4	Washer, Neoprene	
101B	70000685	2	Spacer	
101C	7027367	1	Switch, Push button	
101C	7027765	1	Lever, Enable	
	1001098192	Ref	CONTROLLER ASSEMBLY (SN 0130010761 through 0130032506)	A
201	1001098192	1	Controller Assembly	
201A	70001250	1	Boot, Rubber (Base of Controller)	
201A	7027766	1	Ring, Retaining	
201A	70001251	1	Bezel, Mounting	
201A	70001252	1	Gasket, Mounting	
201B	70000084	1	Boot, Rubber (Steer Switch)	
201B	70000082	2	Microswitch	
201B	7027365	1	Actuator, Handle	
201B	70000684	2	Screw	
201B	70000686	2	Screw	
201B	70000683	4	Washer, Neoprene	
201B	70000685	2	Spacer	
201B	70001253	1	Gasket, Handle	
201C	7027765	1	Lever, Enable	
201C	7027367	1	Switch, Push button (Note: Not Shown - Located Behind Lever)	

SECTION 3 - MAST

SECTION 3 - MAST

FIGURE 3-1. MAST ASSEMBLY AND INSTALLATION

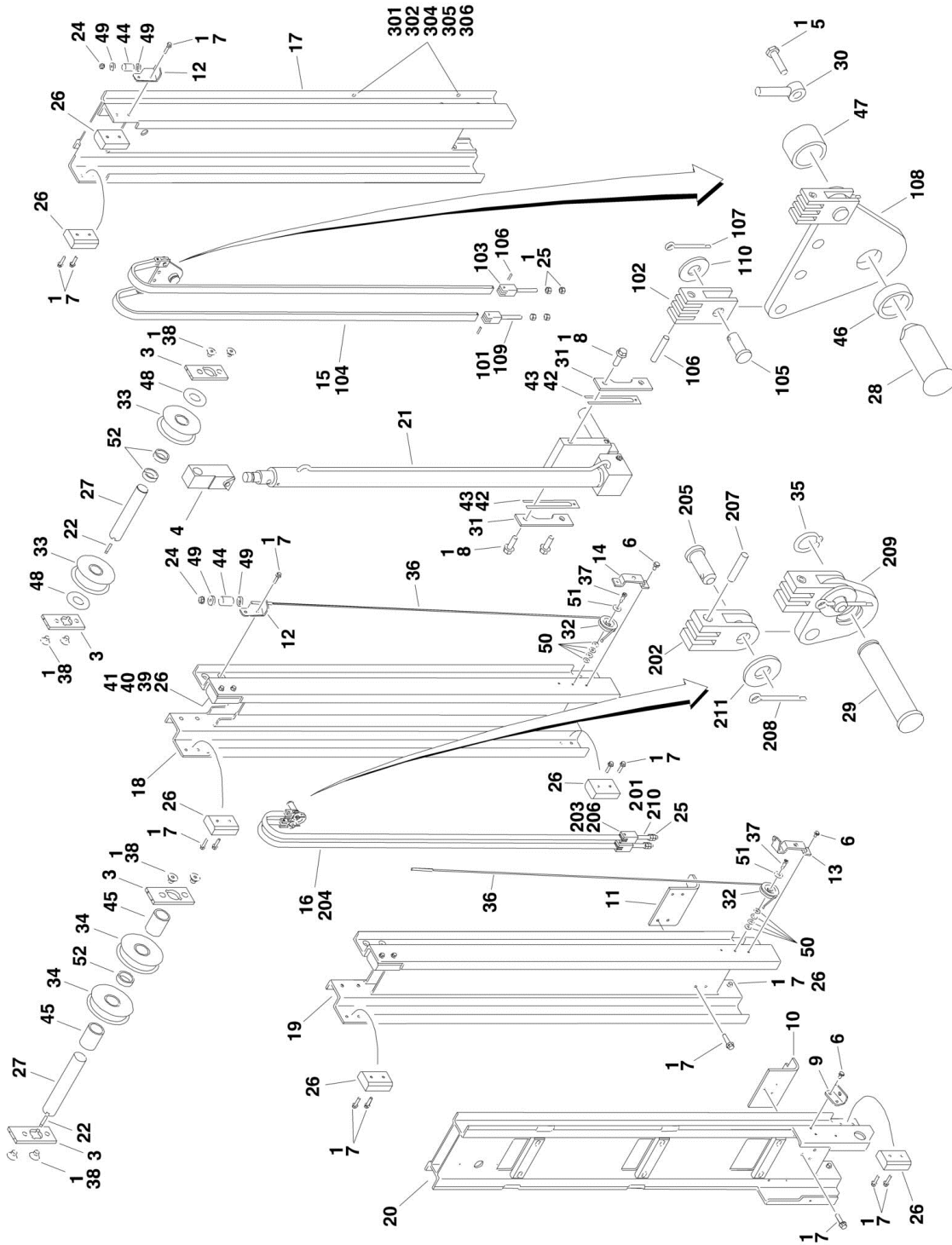

SECTION 3 - MAST

FIGURE 3-1. MAST ASSEMBLY AND INSTALLATION

ITEM	PART NUMBER	QTY	DESCRIPTION	REV
	0801394	Ref	MAST ASSEMBLY	D
1	0100011	AR	Locking Compound	
3	0362735	4	Bar, Sheave Pin Support	
4	0561341	1	Block, Chain Anchor	
5	0721006	1	Screw, Machine #10-24NC x 3/4in	
6	0791003	6	Screw #10-24NC x 3/8in	
7	0811408	31	Screw 1/4in-20NC x 1in	
8	0791812	4	Screw 1/2in-13NC x 1-1/2in	
9	0902047	1	Bracket, Sequence Cable	
10	0902423	1	Bracket, Bottom Chain Attach	
11	0902424	1	Bracket, Bottom Chain Attach	
12	0902431	2	Bracket, Sequence Cable	
13	0902445	1	Bracket, Sequence Cable	
14	0902698	1	Bracket, Sequence Cable	
15	1260375	1	Chain Assy - #446 (See Items 101-110 for Breakdown)	
16	1260376	1	Chain Assy - #444 (See Items 201-211 for Breakdown)	
17	1271567	1	Channel, Mast #1	
18	1271568	1	Channel, Mast #2	
19	1271569	1	Channel, Mast #3	
20	1271577	1	Channel, Header	
21		Ref	Lift Cylinder Assembly Option (See CYLINDER SECTION for Breakdown)	
21	1684348	NLA	Lift Cylinder Assembly (Use p/n 1001225209) (Prior to SN 0130011099)	
21	1684531	NLA	Lift Cylinder Assembly (Use p/n 1001225209) (SN 0130011099 through 0130032506)	
22	2880310	2	Key	
23	3020041	AR	Lubricant (Not Shown - Used on Slides)	
24	3311408	2	Nut, Flanged 1/4in-20NC	
25	3311601	8	Nut 3/8in-16 NC	
26	3340845	12	Pad, Slide Guide	
27	3422717	2	Pin, Sheave	
28	3422750	1	Pin, Chain Equalizer	
29	3422752	1	Pin, Chain Equalizer	
30	3422757	1	Pin, Keeper	
31	3570893	2	Plate, Cylinder Mounting	
32	3580269	2	Sheave, Sequence Cable	
33	3580286	2	Sheave Assembly	
33	0440246	2	Bearing (1 Per Assembly)	
34	3580293	2	Sheave Assembly	
34	0440249	2	Bearing (1 Per Assembly)	
35	3760383	1	Ring, Retaining	
36	3890039	2	Cable, Sequence	
37	3900187	2	Screw, Shoulder	
38	3900192	8	Screw, Countersunk 3/8in-16NC x 1/2in	
39	4070860	AR	Shim, Slide Pad	
40	4070861	AR	Shim, Slide Pad	
41	4070862	AR	Shim, Slide Pad	
42	4070970	AR	Shim, Cylinder Mount	
43	4070971	AR	Shim, Cylinder Mount	

SECTION 3 - MAST

ITEM	PART NUMBER	QTY	DESCRIPTION	REV
44	4160124	2	Spring	
45	4567491	2	Tube, Spacer	
46	4567750	1	Tube, Spacer	
47	4567751	1	Tube, Spacer	
48	4740007	2	Washer, Thrust	
49	4740414	4	Washer, Cup	
50	4751000	8	Flatwasher #10 Wide	
51	4751500	2	Flatwasher 5/16in Wide	
52	4569003	3	Tube, Spacer	
	0273417	1	Mast Kit (Includes Items 17-20)	G
	1260375	Ref	CHAIN ASSEMBLY - #446 CHAIN	B
101	0100062	AR	Loctite #RC/640	
102	0561153	2	Block, Chain Anchor	
103	0561409	2	Block, Chain Anchor	
104	Purchased Assy	AR	Chain	
105	3422338	2	Pin, Equalizer	
106	3422346	4	Pin, Grooved	
107	3450304	2	Pin, Cotter	
108	3571101	1	Plate, Chain Adjustment	
109	4300111	2	Stud	
110	4751500	2	Flatwasher 5/16in	
	1260376	Ref	CHAIN ASSEMBLY - #444 CHAIN	C
201	0100062	AR	Loctite #RC/640 (Use p/n 0100019)	
202	0561149	2	Block, Chain Anchor	
203	0561408	2	Block, Chain Anchor	
204	Purchased Assy	AR	Chain	
205	3422338	2	Pin, Equalizer	
206	3422346	2	Pin, Grooved	
207	3422355	2	Pin	
208	3450304	2	Pin, Cotter	
209	3571103	1	Plate, Chain Adjustment	
210	4300111	2	Stud	
211	4751500	2	Flatwasher 5/16in	
	0273545	Ref	MAST INSTALLATION	B
301	0100019	AR	Locking Compound	
302	0641609	3	Bolt 3/8in-16NC x 1-1/8in	
304	3311601	4	Nut 3/8in-16NC	
305	4711600	8	Flatwasher 3/8in Narrow	
306	0641612	1	Bolt 3/8in-16NC x 1-1/2in	

SECTION 4 - PLATFORM

SECTION 4 - PLATFORM

FIGURE 4-1. PLATFORM INSTALLATION

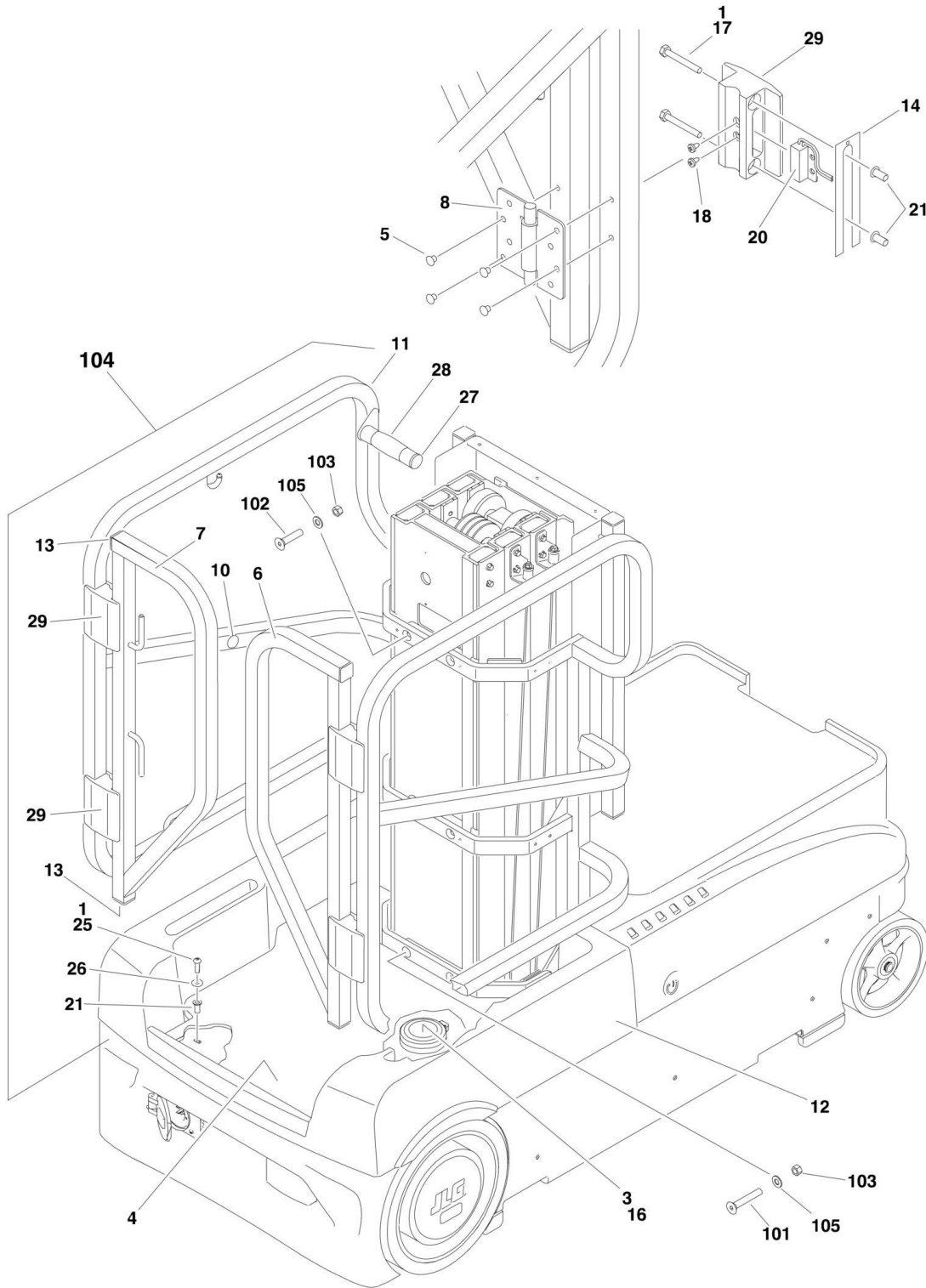

SECTION 4 - PLATFORM

FIGURE 4-1. PLATFORM INSTALLATION

ITEM	PART NUMBER	QTY	DESCRIPTION	REV
	3510865	Ref	PLATFORM ASSEMBLY (ALL SPECS EXCEPT AUSTRALIAN SPECS) (Prior to SN 0130022207)	I
	3510865	Ref	PLATFORM ASSEMBLY (AUSTRALIAN SPECS) (Prior to SN 0130018678)	I
1	0100011	AR	Locking Compound	
3		Ref	Screw Options:	
3	0751006	2	Screw (Prior to SN 0130012278)	
3	0751003	2	Screw (SN 0130012278 through 0130022207)	
4	1671168	1	Floor, Platform	
5	2080040	16	Fastener, Huck	
6	2410012	1	Rail, Door (Right Side)	
7	2410013	1	Rail, Door (Left Side)	
8	2600294	4	Hinge	
10	3340962	2	Pad	
11	3510860	1	Rail, Platform	
12	3510862	1	Pan, Molded Platform	
13	3520072	8	Cap-Plug	
14	4071095	AR	Shim	
16	4360572	1	Footswitch	
17	0641416	8	Bolt 1/4in-20NC x 2in	
18	0751003	4	Screw	
20	4360573	2	Switch, Proximity	
21	2080043	13	Rivnut	
23	8882320	AR	Sealant, Seam (Not Shown)	
25	3900258	5	Screw, Button Head 1/4in-20NC x 3/4in	
26	4711400	5	Flatwasher 1/4in Narrow	
27	1120582	1	Plug	
28	1120583	1	Grip, Foam	
29		Ref	Stop/Hinge, Gate Options:	
29	4220233	NLA	Stop/Hinge -Bottom (Use p/n 4220309) (Prior to SN 0130009782)	
29	4220234	NLA	Stop/Hinge - Top (Use p/n 4220309) (Prior to SN 0130009782)	
29	4220309	4	Stop/Hinge - Top and Bottom (SN 0130009782 through 0130022207)	
	0274055	Ref	PLATFORM INSTALLATION (ALL SPECS EXCEPT AUSTRALIAN SPEC) (Prior to SN 0130022207)	D
	0274055	Ref	PLATFORM INSTALLATION (AUSTRALIAN SPEC) (Prior to SN 0130018678)	D
		Ref	Note: Replacement decals must be ordered separately - See DECALS SECTION.	
101	0641622	2	Bolt 3/8in-16NC x 2-3/4in	
102	0741614	4	Screw, Flat Head 3/8in-16NC x 1-3/4in	
103	3311605	6	Locknut 3/8in-16NC	
104	3510865	1	Platform Assembly (Includes Items 1-29)	
105	4711600	8	Flatwasher 3/8in Narrow	

SECTION 4 - PLATFORM

FIGURE 4-2. PLATFORM INSTALLATION

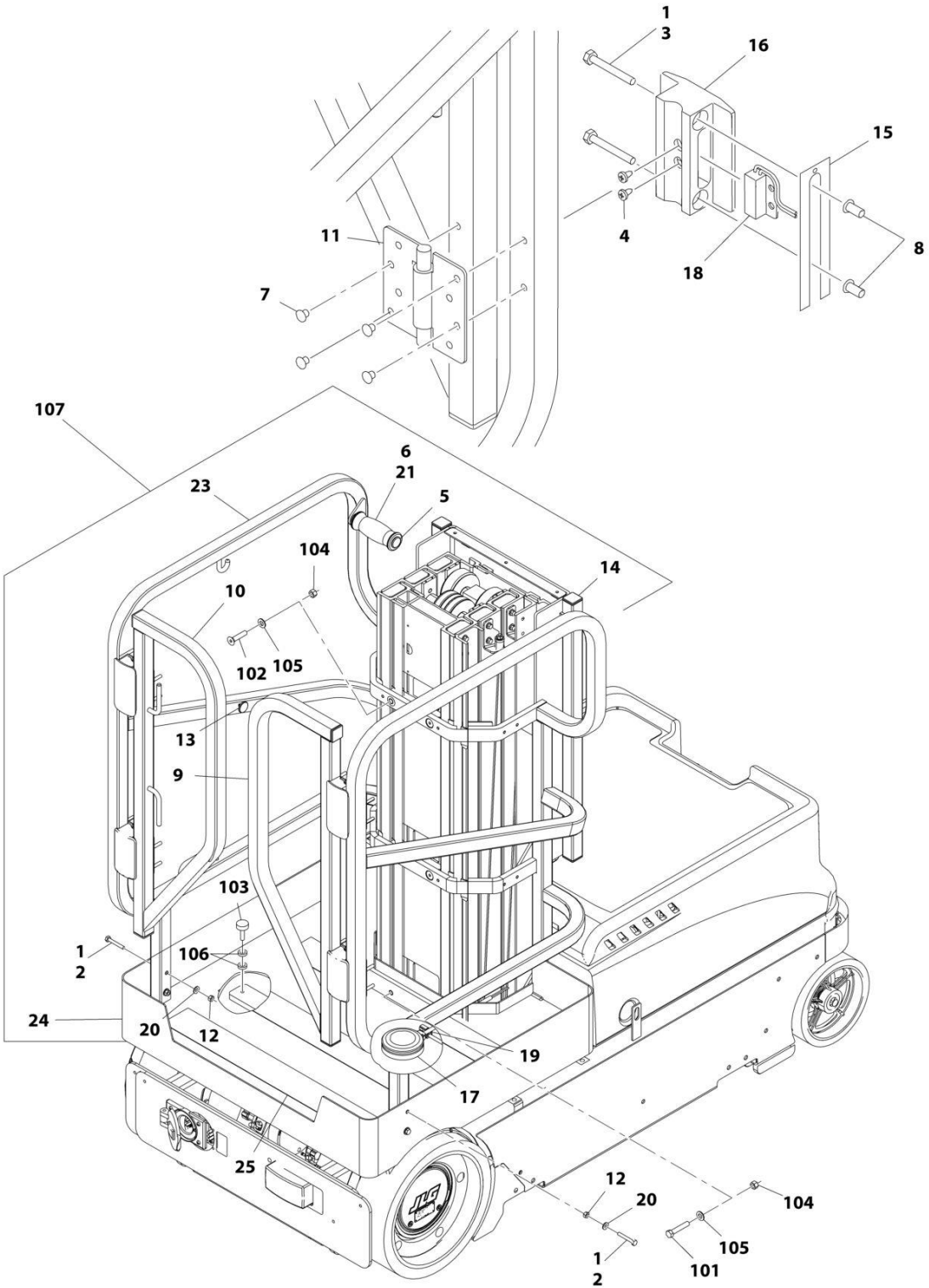

ART_1001171844-E

SECTION 4 - PLATFORM

FIGURE 4-2. PLATFORM INSTALLATION

ITEM	PART NUMBER	QTY	DESCRIPTION	REV
	1001171844	Ref	PLATFORM ASSEMBLY (ALL SPECS EXCEPT AUSTRALIAN SPECS) (SN 0130022207 through 0130032506)	F
1	0100011	AR	Locking Compound	
2	0681414	4	Bolt 1/4 x 1-3/4	
3	0641416	8	Bolt 1/4in-20NC x 2in	
4	0751003	6	Screw	
5	1120582	1	Plug	
6	1120583	1	Grip, Foam	
7	2080040	16	Fastener, Huck	
8	2080043	8	Rivnut	
9	2410012	1	Rail, Door (Right Side)	
10	2410013	1	Rail, Door (Left Side)	
11	2600294	4	Hinge	
12	3311405	4	Locknut 1/4in-20NC	
13	3340962	2	Pad	
14	3520072	8	Cap-Plug	
15	4071095	AR	Shim	
16	4220309	4	Stop, Swing Gate	
17	4360572	1	Footswitch	
18	4360573	2	Switch, Proximity	
19	4460320	2	Connector - 2 Position	
20	4711400	8	Flatwasher 1/4in Narrow	
21	8882320	AR	Sealant, Seam	
23	1001171828	1	Rail	
24	1001171840	1	Base	
25	1001099638	3 in	Tape, Safety	
	1001171916	Ref	PLATFORM INSTALLATION (ALL SPECS EXCEPT AUSTRALIAN SPEC) (SN 0130022207 through 0130032506)	C
		Ref	Note: Replacement decals must be ordered separately - See DECALS SECTION.	
101	0641616	2	Bolt 3/8in-16NC x 2in	
102	0741614	4	Screw, Flat Head 3/8in-16NC x 1-3/4in	
103	0940049	2	Hood, Stopper	
104	3311605	6	Locknut 3/8in-16NC	
105	4711600	8	Flatwasher 3/8in Narrow	
106	4740139	4	Washer	
107	1001171844	1	Platform Assembly (Includes Items 1-25)	

SECTION 4 - PLATFORM

FIGURE 4-3. PLATFORM INSTALLATION

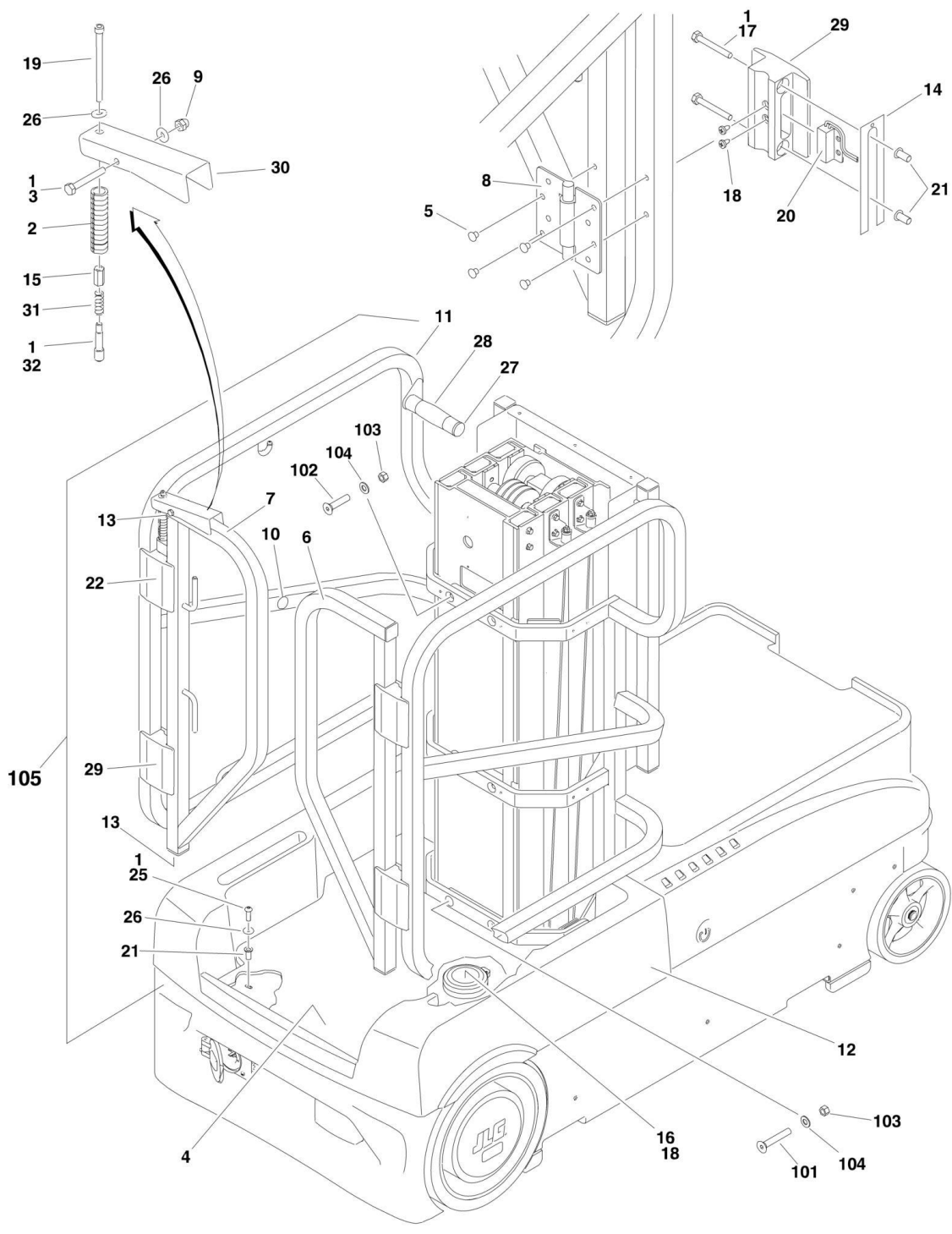

SECTION 4 - PLATFORM

FIGURE 4-3. PLATFORM INSTALLATION

ITEM	PART NUMBER	QTY	DESCRIPTION	REV
	1001148752	Ref	PLATFORM ASSEMBLY (AUSTRALIAN SPEC) (SN 0130018678 through 0130022207)	B
1	0100011	AR	Locking Compound	
2	280013	6 in/15cm	Conduit	
3	0641415	2	Bolt 1/4in-20NC x 1-7/8in	
4	1671168	1	Floor, Platform	
5	2080040	16	Fastener, Huck	
6	1001148753	1	Rail, Door (Right Side)	
7	1001148754	1	Rail, Door (Left Side)	
8	2600294	4	Hinge	
9	3300151	2	Nut, Acorn 1/4in-20NC	
10	3340962	2	Pad	
11	3510860	1	Rail, Platform	
12	3510862	1	Pan, Molded Platform	
13	3520072	8	Cap-Plug	
14	4071095	AR	Shim	
15	3300381	2	Nut, Coupling	
16	4360572	1	Footswitch	
17	0641416	8	Bolt 1/4in-20NC x 2in	
18	0751003	6	Screw	
19	3931456	2	Bolt 1/4in-20NC x 3-1/2in	
20	4360573	2	Switch, Proximity	
21	2080043	13	Rivnut	
22	1001100141	2	Stop, Swing Gate	
23	8882320	AR	Sealant, Seam (Not Shown)	
25	3900258	5	Screw, Button Head 1/4in-20NC x 3/4in	
26	4711400	9	Flatwasher 1/4in Narrow	
27	1120582	1	Plug	
28	1120583	1	Grip, Foam	
29	4220309	2	Stop, Swing Gate	
30	1001100142	2	Handle	
31	1001100634	2	Spring	
32	1001101529	2	Pin, Plunger	
	1001149003	Ref	PLATFORM INSTALLATION (AUSTRALIAN SPEC) (SN 0130018678 through 0130022207)	B
		Ref	Note: Replacement decals must be ordered separately – See DECALS SECTION.	
101	0641622	2	Bolt 3/8in-16NC x 2-3/4in	
102	0741614	4	Screw, Flat Head 3/8in-16NC x 1-3/4in	
103	3311605	6	Locknut 3/8in-16NC	
104	4711600	8	Flatwasher 3/8in Narrow	
105	1001148752	1	Platform Assembly (Includes Items 1-32)	

SECTION 4 - PLATFORM

FIGURE 4-4. PLATFORM INSTALLATION

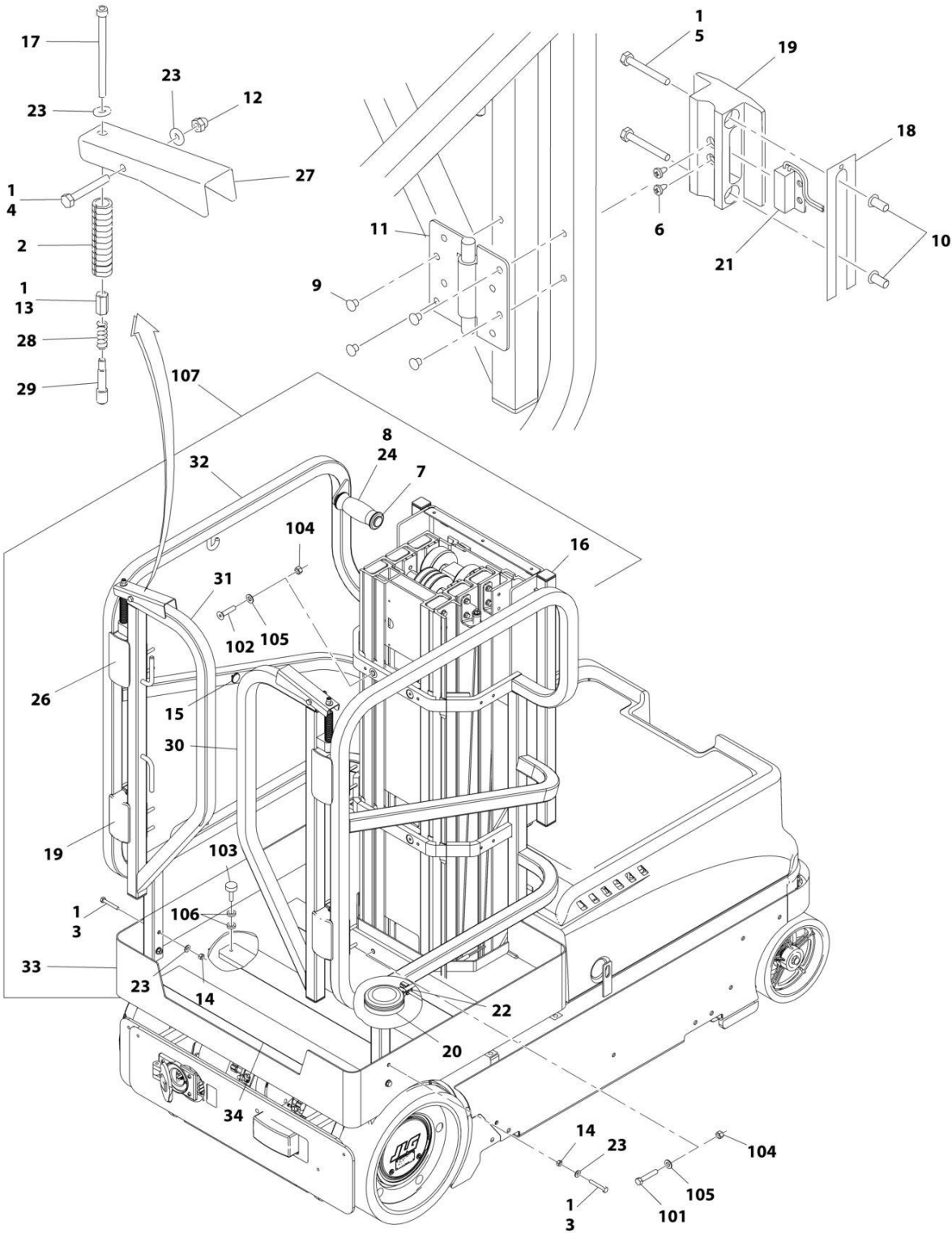

ART_1001174513-E

SECTION 4 - PLATFORM

FIGURE 4-4. PLATFORM INSTALLATION

ITEM	PART NUMBER	QTY	DESCRIPTION	REV
	1001174513	Ref	PLATFORM ASSEMBLY (AUSTRALIAN SPEC) (SN 0130022207 through 0130032506)	F
1	0100011	AR	Locking Compound	
2	280013	5 ft	Conduit	
3	0681414	4	Bolt, 1/4 x 1-3/4	
4	0641415	2	Bolt 1/4in-20NC x 1-7/8in	
5	0641416	8	Bolt 1/4in-20NC x 2in	
6	0751003	6	Screw	
7	1120582	1	Plug	
8	1120583	1	Grip, Foam	
9	2080040	16	Fastener, Huck	
10	2080043	8	Rivnut	
11	2600294	4	Hinge	
12	3300151	2	Nut, Acorn 1/4in-20NC	
13	3300381	2	Nut, Coupling	
14	3311405	4	Locknut 1/4in-20NC	
15	3340962	2	Pad	
16	3520072	8	Cap-Plug	
17	3931456	2	Bolt 1/4in-20NC x 3-1/2in	
18	4071095	AR	Shim	
19	4220309	2	Stop, Swing Gate	
20	4360572	1	Footswitch	
21	4360573	2	Switch, Proximity	
22	4460320	2	Connector - 2 Position	
23	4711400	12	Flatwasher 1/4in Narrow	
24	8882320	AR	Sealant, Seam	
26	1001100141	2	Stop, Swing Gate	
27	1001100142	2	Handle	
28	1001100634	2	Spring	
29	1001101529	2	Pin, Plunger	
30	1001148753	1	Rail, Door (Right Side)	
31	1001148754	1	Rail, Door (Left Side)	
32	1001171828	1	Rail	
33	1001171840	1	Base	
34	1001099638	3 in	Tape, Safety	
	1001174586	Ref	PLATFORM INSTALLATION (AUSTRALIAN SPEC)	D
		Ref	Note: Replacement decals must be ordered separately – See DECALS SECTION.	
101	0641616	1	Bolt 3/8in-16NC x 2in	
102	0741614	1	Screw, Flat Head 3/8in-16NC x 1.75 LG	
103	0940049	1	Stopper, Hood	
104	3311605	1	Locknut 3/8in-16NC	
105	4711600	1	Flatwasher 3/8in Narrow	
106	4740139	1	Washer	
107	1001174513	1	Platform Assembly (Includes Items 1-34)	

SECTION 4 - PLATFORM

FIGURE 4-5. MATERIAL TRAY INSTALLATION

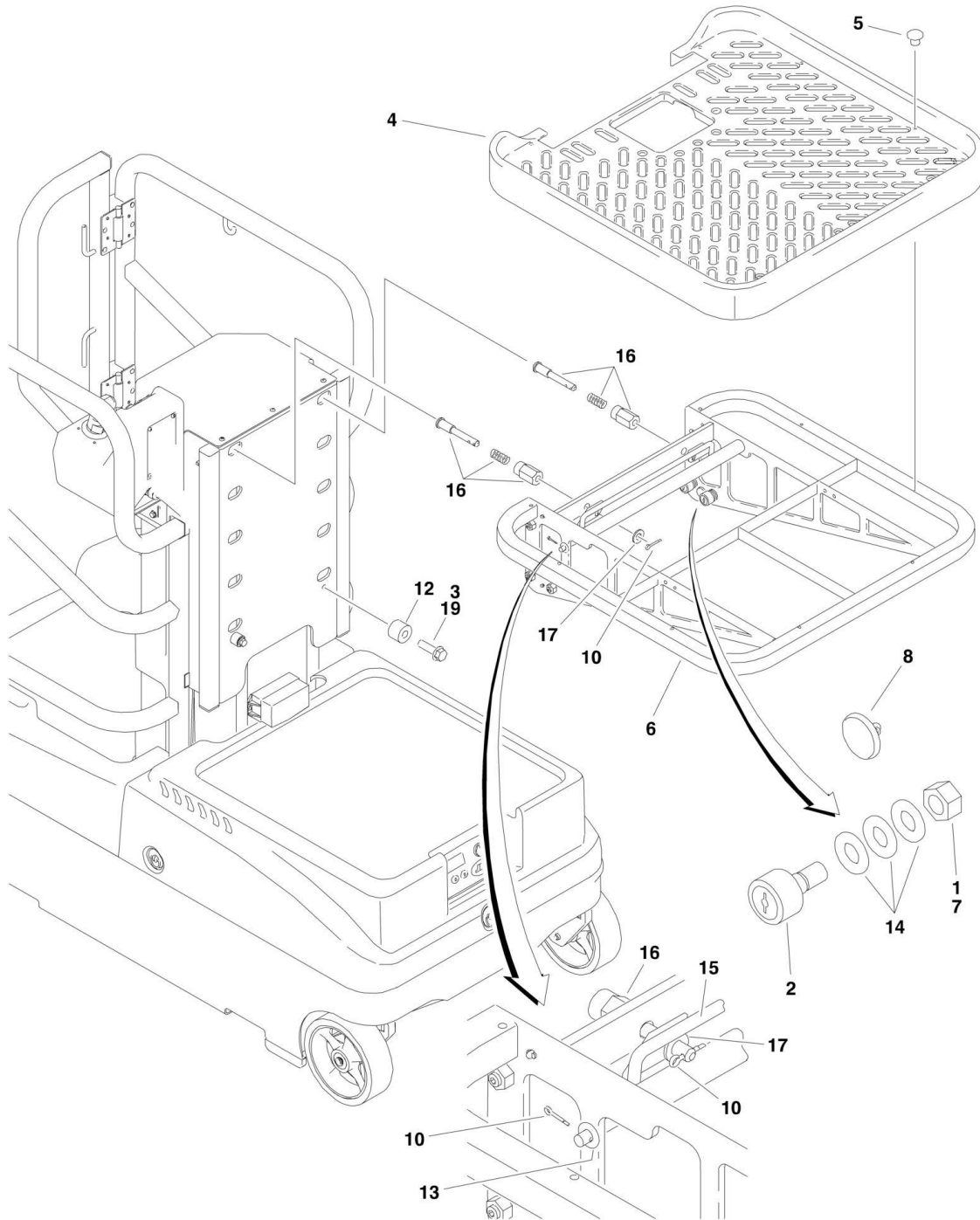

SECTION 4 - PLATFORM

FIGURE 4-5. MATERIAL TRAY INSTALLATION

ITEM	PART NUMBER	QTY	DESCRIPTION	REV
	0274011	Ref	MATERIAL TRAY INSTALLATION (Prior to SN 0130022207)	G
1	0100011	AR	Locking Compound	
2	0440287	6	Bearing	
3	0811610	2	Screw 3/8in-16NC x 1-1/4in	
4	1580027	1	Tray	
5	2080040	8	Fastener, Huck	
6	2360684	1	Frame	
7	3321701	6	Nut 7/16in-20NF	
8	3340962	4	Pad	
10	3450302	4	Pin, Cotter	
12	4220222	2	Stop	
13	4711600	2	Flatwasher 3/8in Narrow	
14	4711700	18	Flatwasher 7/16in Narrow	
15	2940165	1	Latch, Material Tray	
16	3423171	NLA	Pin, Plunger (Use p/n 1001097488)	
17	4740476	2	Thrust Washer	
19	0100019	AR	Locking Compound	

SECTION 4 - PLATFORM

FIGURE 4-6. MATERIAL TRAY INSTALLATION

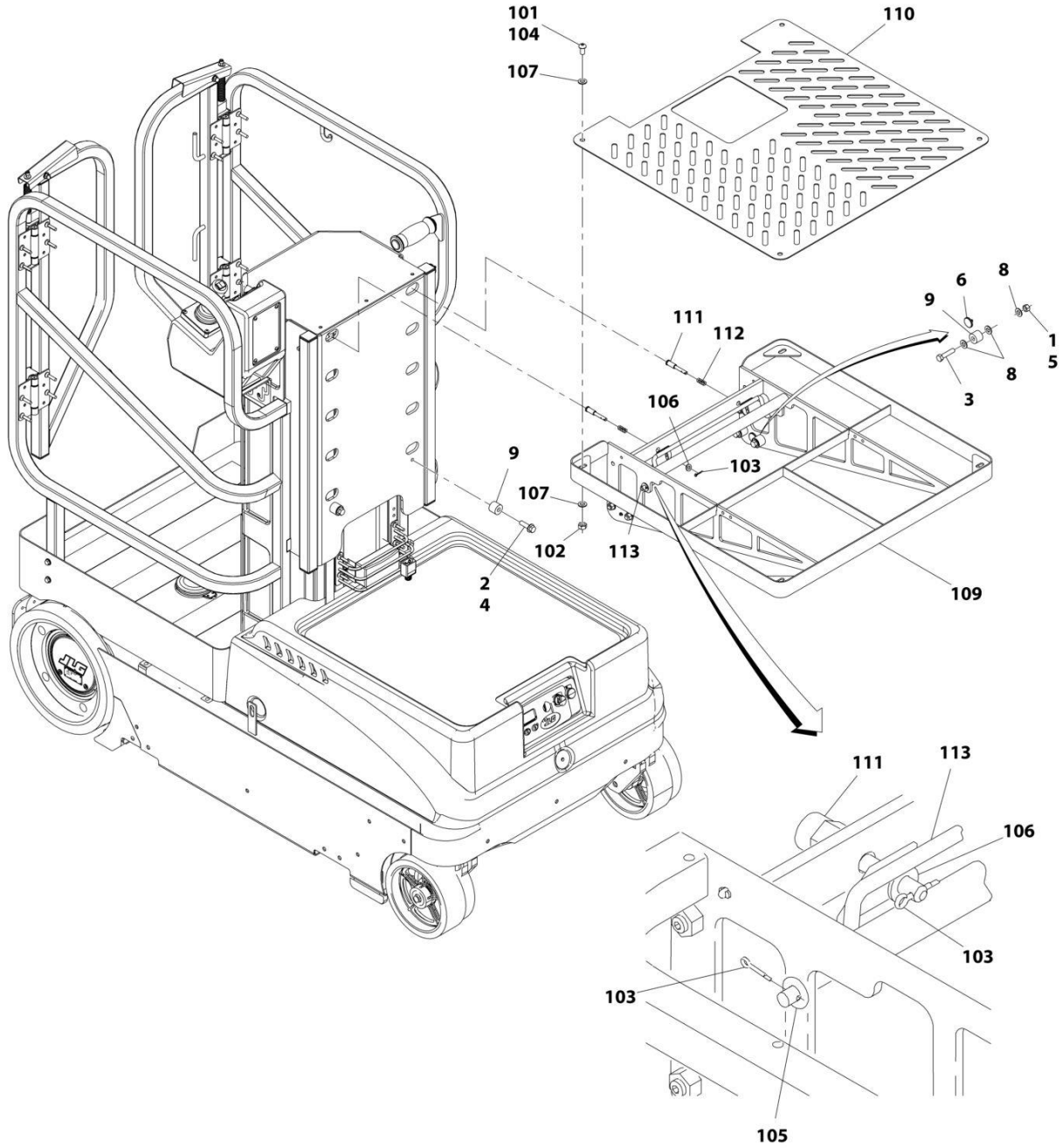

ART_1001171857-E

SECTION 4 - PLATFORM

FIGURE 4-6. MATERIAL TRAY INSTALLATION

ITEM	PART NUMBER	QTY	DESCRIPTION	REV
	1001171857	Ref	MATERIAL TRAY INSTALLATION (SN 0130022207 through 0130032506)	G
1	0100011	AR	Locking Compound	
2	0100019	AR	Locking Compound	
3	0641613	6	Bolt 3/8 x 1-5/8	
4	0811610	2	Screw 3/8in-16NC x 1-1/4in	
5	3271601	6	Nut, 3/8 Grades	
6	3340962	4	Pad	
8	4711600	17	Flatwasher 3/8in Narrow	
9	1001181407	8	Bar, Spacer	
	1001171855	1	Material Tray Assembly (See Item 101-113 For Breakdown) (SN 0130022207 through 0130032506)	D
101	0100011	AR	Locking Compound	
102	3291007	4	Nut, M10	
103	3450302	6	Pin, Cotter	
104	3900393	4	Screw, M10 x 20	
105	4711600	2	Flatwasher 3/8in Narrow	
106	4811900	2	Washer, M8	
107	4812000	8	Washer, M10	
109	1001171846	1	Shelf, Material Tray	
110	1001171847	1	Plate, Base Shelf	
111	1001171856	2	Pin, Plunger	
112	1001171869	2	Spring, Plunger	
113	2940165	1	Latch, Material Tray	

SECTION 4 - PLATFORM

FIGURE 4-7. OPTIONAL BICYCLE CARRIERS INSTALLATION

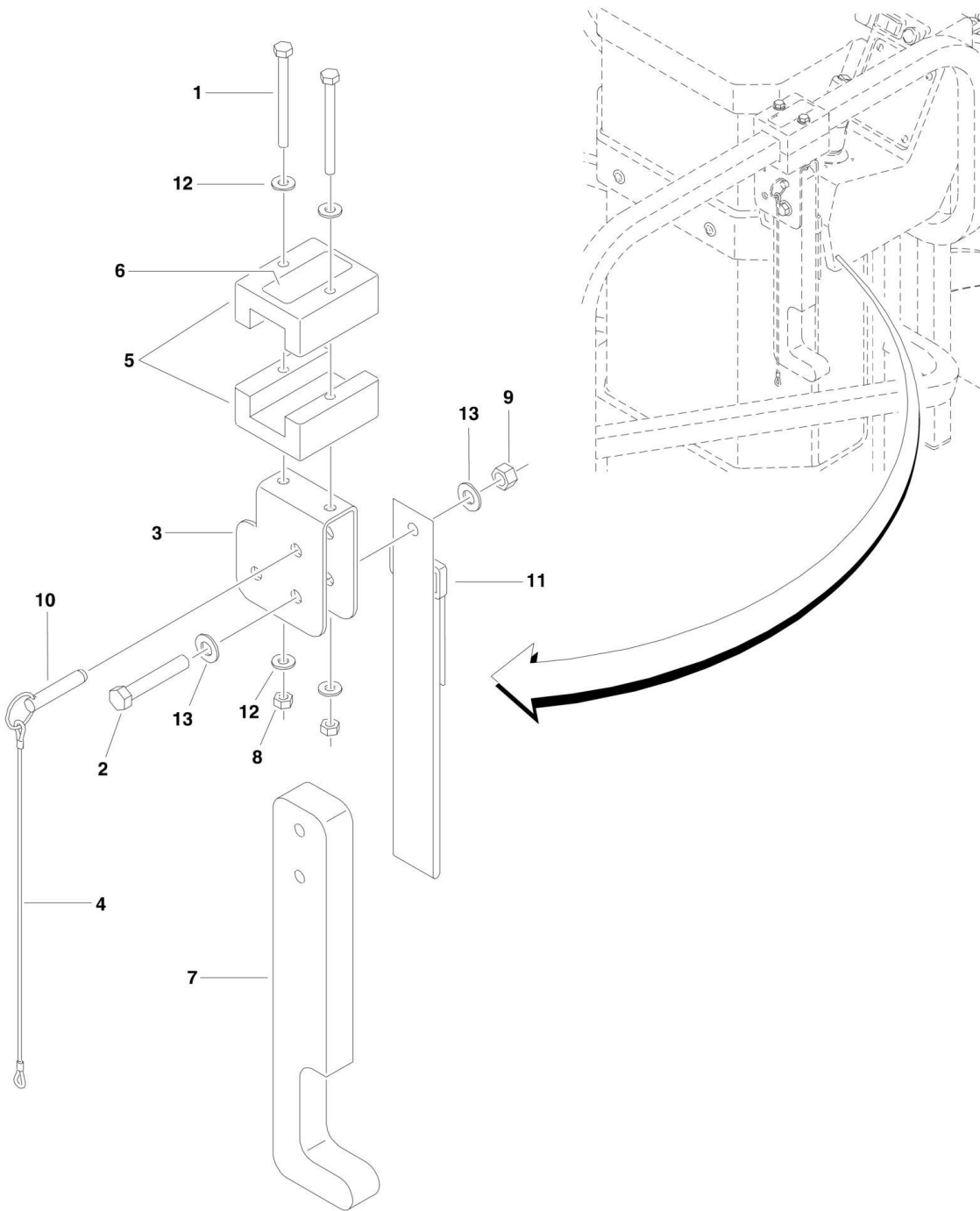

SECTION 4 - PLATFORM

FIGURE 4-7. OPTIONAL BICYCLE CARRIERS INSTALLATION

ITEM	PART NUMBER	QTY	DESCRIPTION	REV
		Ref	BICYCLE CARRIER INSTALLATION	
	0273570	Ref	Carrier on One Side Only	C
	0273571	Ref	Carrier on Both Sides	C
		Ref	Note: Qty Shown is for One Side Only. Double for Both Sides.	
1	0641424	2	Bolt 1/4in-20NC x 3in	
2	0641618	1	Bolt 3/8in-16NC x 2-1/4in	
3	0902895	1	Bracket, Hanger	
4	1060799	1	Lanyard	
5	1320316	1	Clamp, Block	
6	1706134	1	Decal - Maximum Capacity	
7	2660121	1	Arm	
8	3311405	2	Locknut 1/4in-20NC	
9	3311605	1	Locknut 3/8in-16NC	
10	3420198	1	Pin, Quick Release	
11	4240163	1	Strap	
12	4711400	4	Flatwasher 1/4in Narrow	
13	4711600	2	Flatwasher 3/8in	

SECTION 4 - PLATFORM

FIGURE 4-8. OPTIONAL RUG CARRIER INSTALLATION

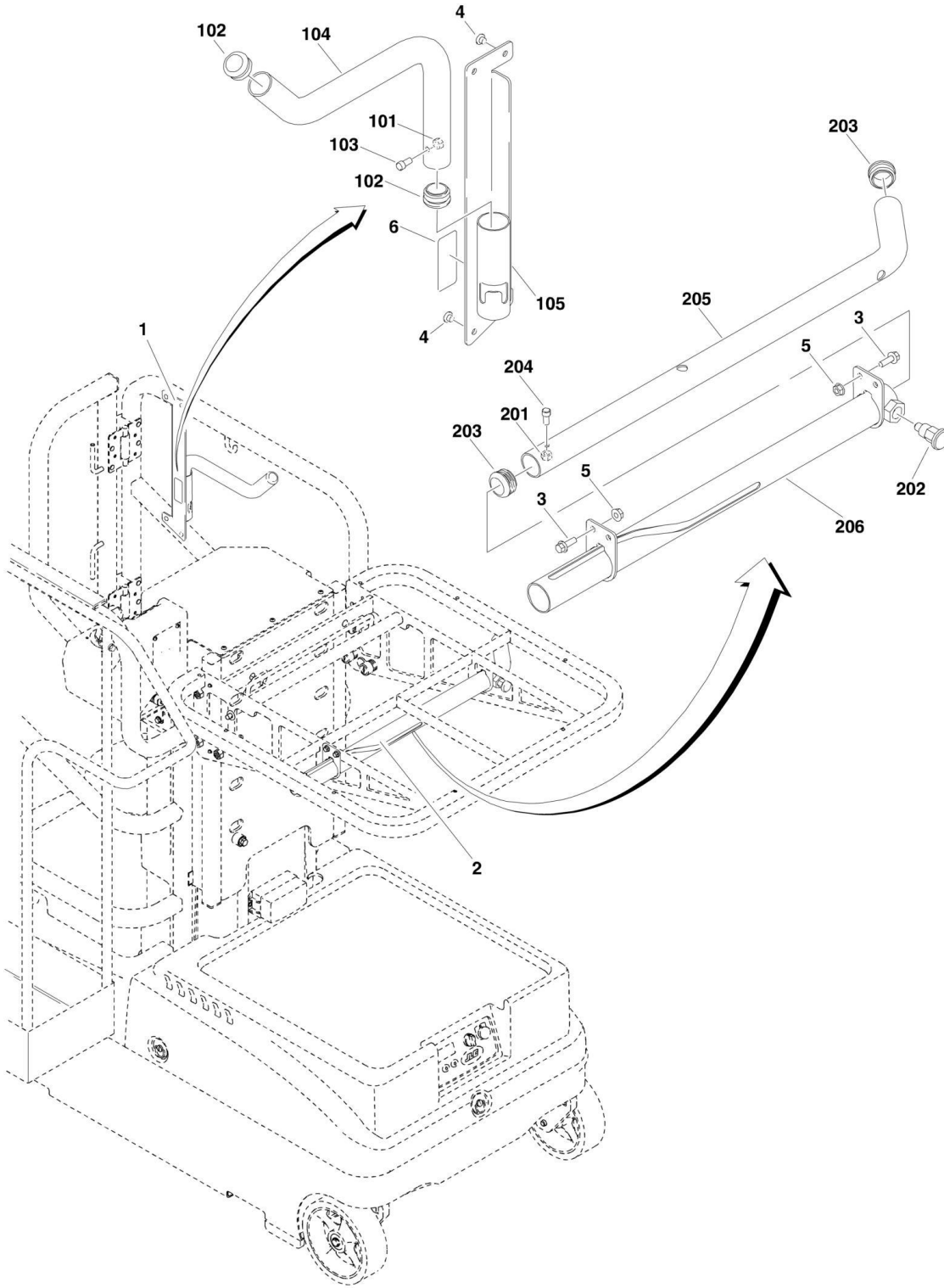

SECTION 4 - PLATFORM

FIGURE 4-8. OPTIONAL RUG CARRIER INSTALLATION

ITEM	PART NUMBER	QTY	DESCRIPTION	REV
	0240107	Ref	RUG CARRIER INSTALLATION	C
1	0240108	1	Accessory, Rug Carrier (Rear) (See Items 101 - 105 for Breakdown)	
2	0240109	1	Accessory, Rug Carrier (Front) (See Items 201 - 206 for Breakdown)	
3	0791406	4	Bolt 1/4 x 3/4	
4	2080040	4	Fastener, Huck	
5	3311408	4	Nut 1/4	
6	1706134	1	Decal - Capacity	
	0240108	Ref	ACCESSORY RUG CARRIER (REAR)	A
101	3311405	1	Nut 1/4	
102	3520176	2	Plug	
103	3931408	1	Screw 1/4 x 1/2	
104	4568208	1	Tube	
105	4630009	1	Carrier Pivot	
	0240109	Ref	ACCESSORY RUG CARRIER (FRONT)	A
201	3311405	1	Nut 1/4	
202	3422744	1	Pin, Plunger	
203	3520176	2	Plug	
204	3931408	1	Screw 1/4 x 1/2	
205	4569158	1	Tube	
206	4630010	1	Carrier Pivot	

SECTION 4 - PLATFORM

FIGURE 4-9. OPTIONAL FLUORESCENT TUBE CADDY ASSEMBLY

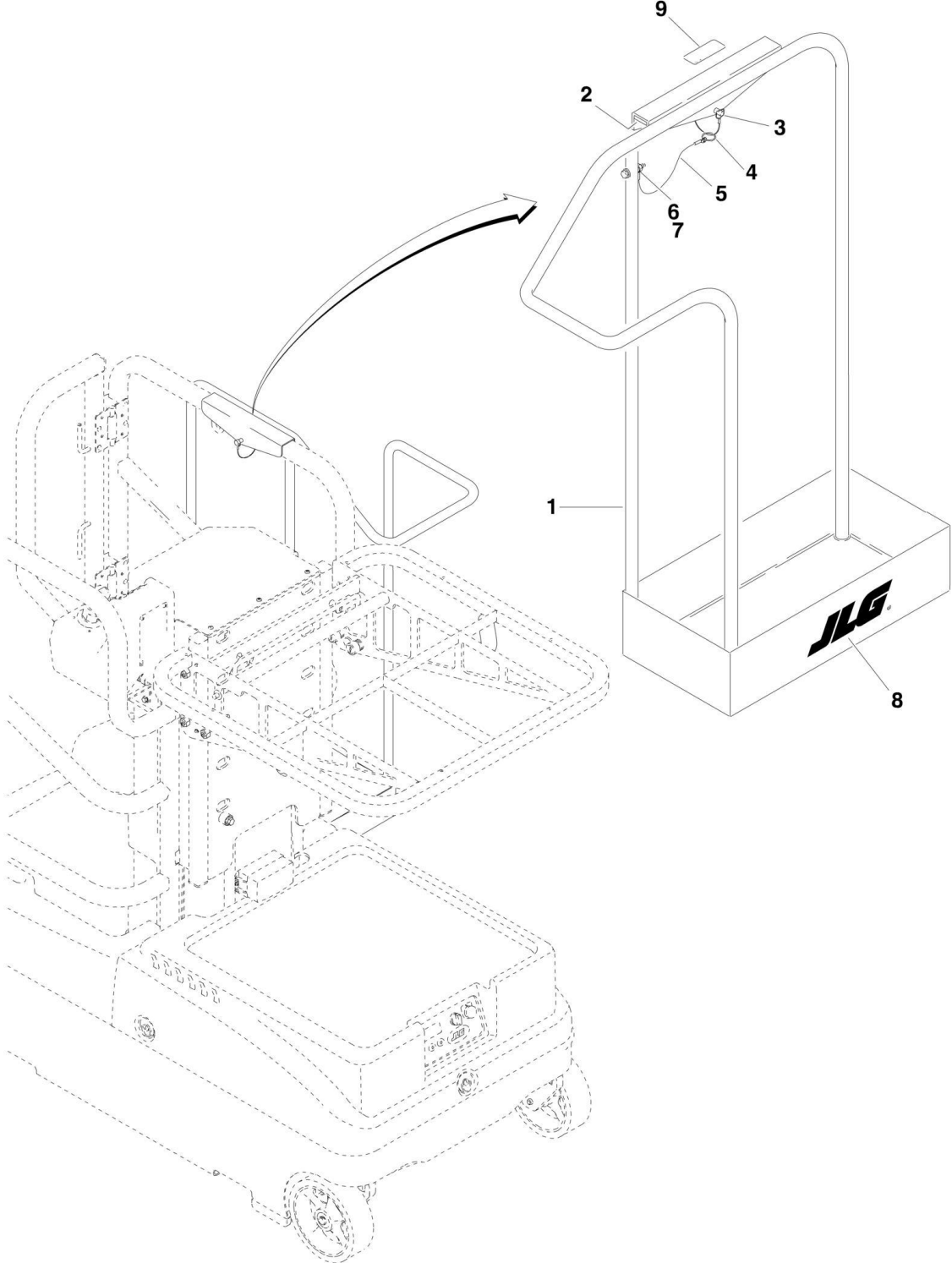

SECTION 4 - PLATFORM

FIGURE 4-9. OPTIONAL FLUORESCENT TUBE CADDY ASSEMBLY

ITEM	PART NUMBER	QTY	DESCRIPTION	REV
	0255040	Ref	FLUORESCENT TUBE CADDY ASSEMBLY	B
1	4844840	1	Caddy, Fluorescent Tube	
2	4280296	2 ft/0.7m	Strip, Wear	
3	3421453	1	Pin, Snapper	
4	3760170	1	Ring, Split	
5	1060380	1	Cable, Lanyard	
6	0641410	1	Bolt 1/4 x 1-1/4	
7	3311405	1	Nut 1/4	
8	1702365	1	Decal - JLG	
9	1706326	1	Decal - Max Capacity (15lb./7kg)	

SECTION 5 - CYLINDER

SECTION 5 - CYLINDER

FIGURE 5-1. LIFT CYLINDER ASSEMBLY (Prior to SN 0130011099)

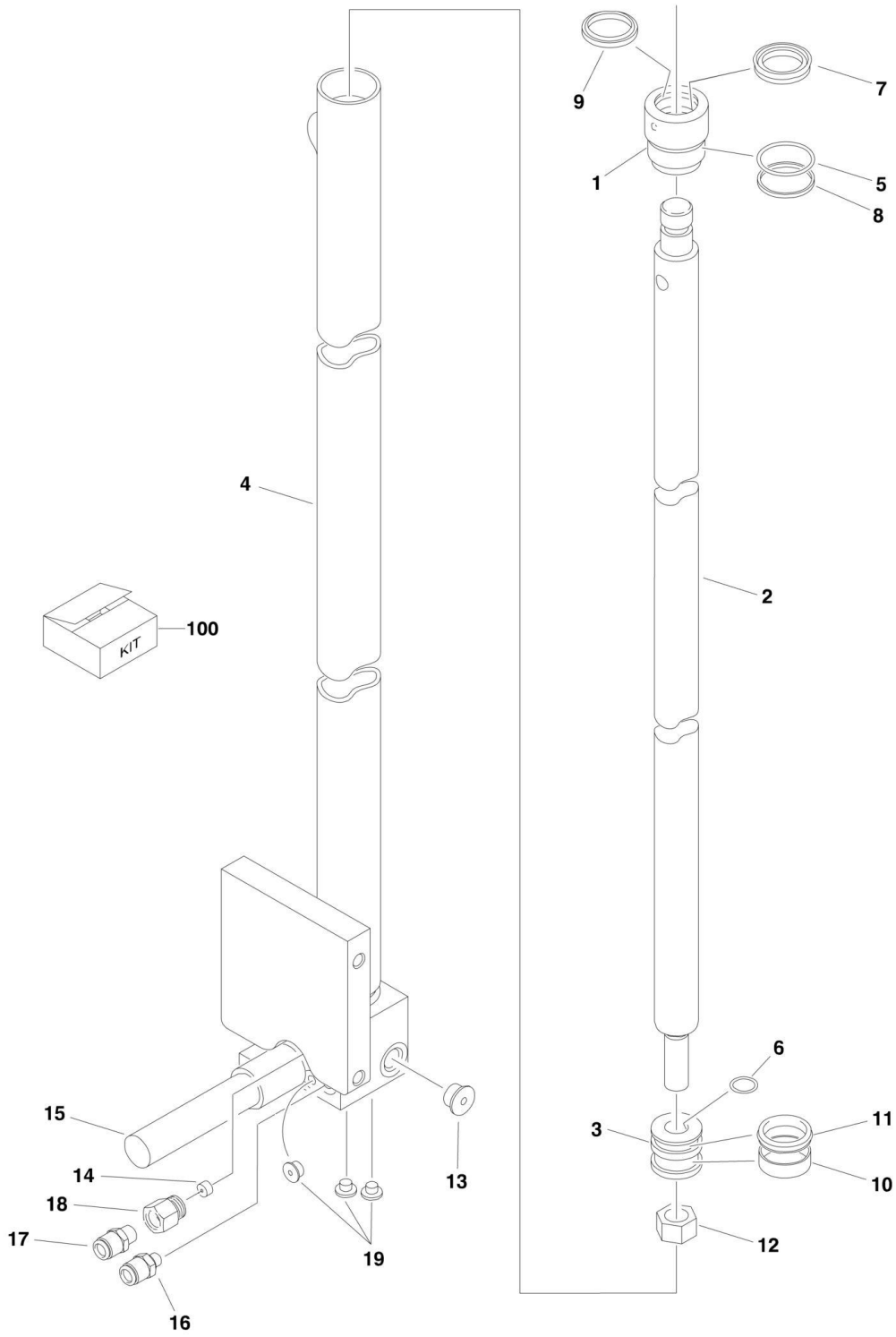

SECTION 5 - CYLINDER

FIGURE 5-1. LIFT CYLINDER ASSEMBLY (Prior to SN 0130011099)

ITEM	PART NUMBER	QTY	DESCRIPTION	REV
		Ref	Note: Original Equipment Cylinder may have been replaced with with a Service Replacement Cylinder. Identify p/n stamped on cylinder before ordering parts. Refer to next figure for Service Replacement Cylinders	
	1684348	Ref	LIFT CYLINDER ASSEMBLY (Prior to SN 0130011099)	H
1	7027847	1	Head	
2	7027848	1	Rod	
3	7027849	1	Piston	
4	7027850	1	Barrel	
5	See Note	NSS	O-Ring (Note: Use Item 100)	
6	See Note	NSS	O-Ring (Note: Use Item 100)	
7	See Note	NSS	Seal, Rod (Note: Use Item 100)	
8	See Note	NSS	Ring, Back-up (Note: Use Item 100)	
9	See Note	NSS	Wiper, Rod (Note: Use Item 100)	
10	See Note	NSS	Ring, Wear (Note: Use Item 100)	
11	See Note	NSS	Seal, Piston (Note: Use Item 100)	
12	7027340	1	Nut	
13	2220886	1	Plug	
13	7027851	1	Valve, Flow Control	
14	7027852	1	Valve, Check	
15	7027853	1	Valve, Manual Descent	
15	See Note	1	Coil (Note: Not Available - Use p/n 7027853)	
16	2221172	1	Fitting	
17	2221173	1	Fitting	
18	2220591	1	Fitting, Reducer	
19	2220883	3	Plug	
		Ref	KIT OPTIONS:	
100	7027855	1	Seal Kit (includes items 5-11)	

SECTION 5 - CYLINDER

FIGURE 5-2. LIFT CYLINDER ASSEMBLY (SN 0130011099 through 0130032506)

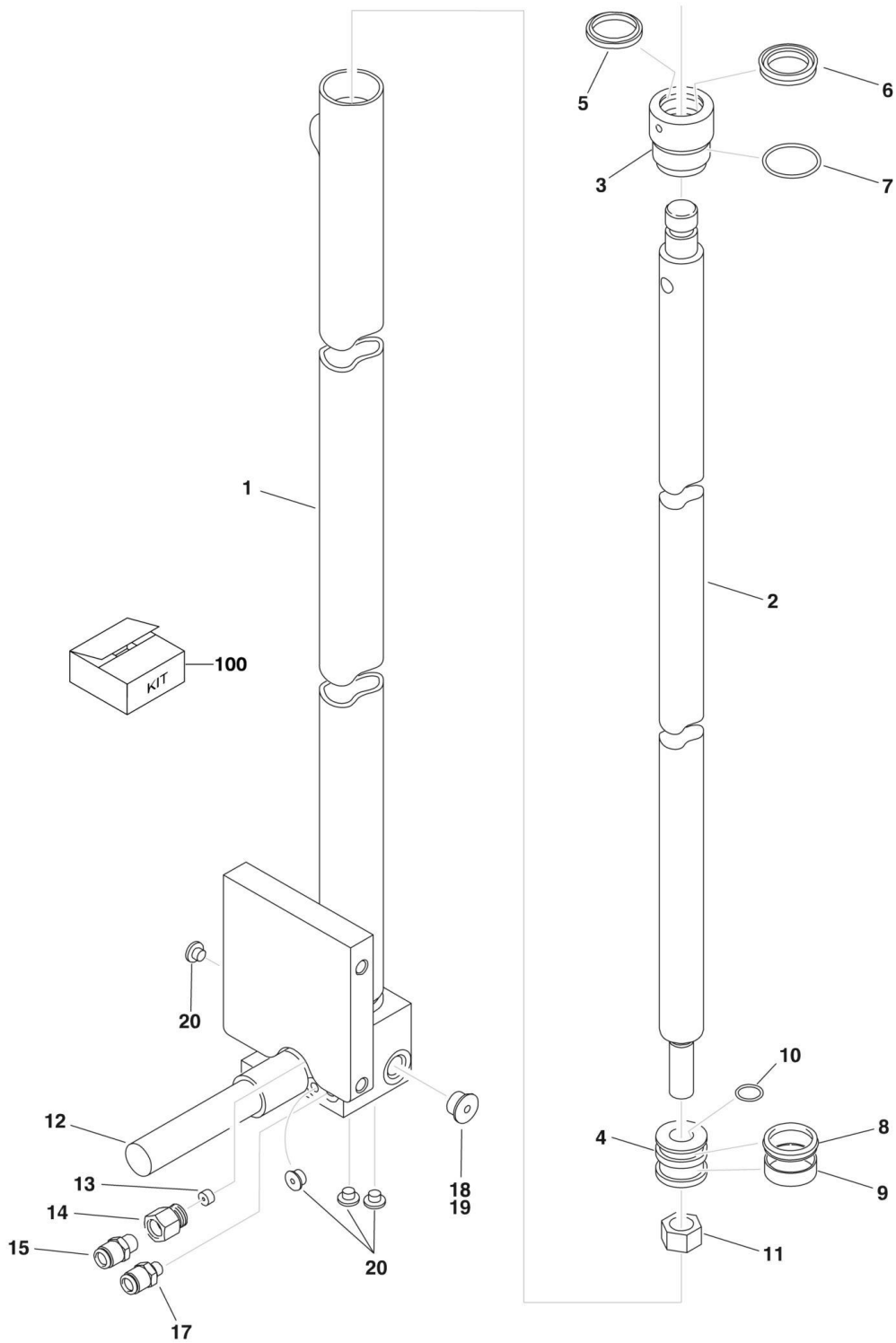

SECTION 5 - CYLINDER

FIGURE 5-2. LIFT CYLINDER ASSEMBLY (SN 0130011099 through 0130032506)

ITEM	PART NUMBER	QTY	DESCRIPTION	REV
	1684531	Ref	LIFT CYLINDER ASSEMBLY (ORIGINAL EQUIPMENT) (SN 0130011099 through 0130032506)	D
	1001225209	Ref	LIFT CYLINDER ASSEMBLY (SERVICE REPLACEMENT)	A
		Ref	Note: Original Equipment Cylinder p/n 1684531 may have been replaced with Service Replacement Cylinder p/n 1001225209. Refer to Number stamped on cylinder before Ordering Parts.	
1	70000991	1	Barrel	
2	70000992	1	Rod	
3	70000993	1	Head	
4	7023392	1	Piston	
5	See Note	NSS	Wiper, Rod (Note: Use Item 100)	
6	See Note	NSS	Seal, Rod (Note: Use Item 100)	
7	See Note	NSS	O-Ring (Note: Use Item 100)	
8	See Note	NSS	Seal, Piston (Note: Use Item 100)	
9	See Note	NSS	Ring, Wear (Note: Use Item 100)	
10	See Note	NSS	O-Ring (Note: Use Item 100)	
11	7023391	1	Nut	
12	70000994	1	Valve, Manual Descent (1684531 Cylinder)	
12	70001113	1	Coil (1684531 Cylinder)	
12	7026625	1	Cartridge (1684531 Cylinder)	
12	7026624	1	Manual Override (1684531 Cylinder)	
12	7026623	1	Seal Kit (1684531 Cylinder)	
12	70006454	1	Valve, Manual Descent (1001225209 Cylinder)	
12	70006455	1	Coil (1001225209 Cylinder)	
12	70006453	1	Cartridge (1001225209 Cylinder)	
12	70006451	1	Manual Override (1001225209 Cylinder)	
13	70000218	1	Valve, Check	
14	2220591	1	Fitting, Reducer	
15	2221173	1	Fitting	
17	2221172	1	Fitting	
18	70000995	1	Valve, Flow Control	
19	See Note	1	Plug (Note: Not Available - Purchase Locally)	
20	See Note	4	Plug (Note: Not Available - Purchase Locally)	
		Ref	KIT OPTIONS:	
100	7023395	1	Seal Kit (Includes Items 5-10)	

SECTION 6 - HYDRAULIC

SECTION 6 - HYDRAULIC

FIGURE 6-1. HYDRAULIC DIAGRAM

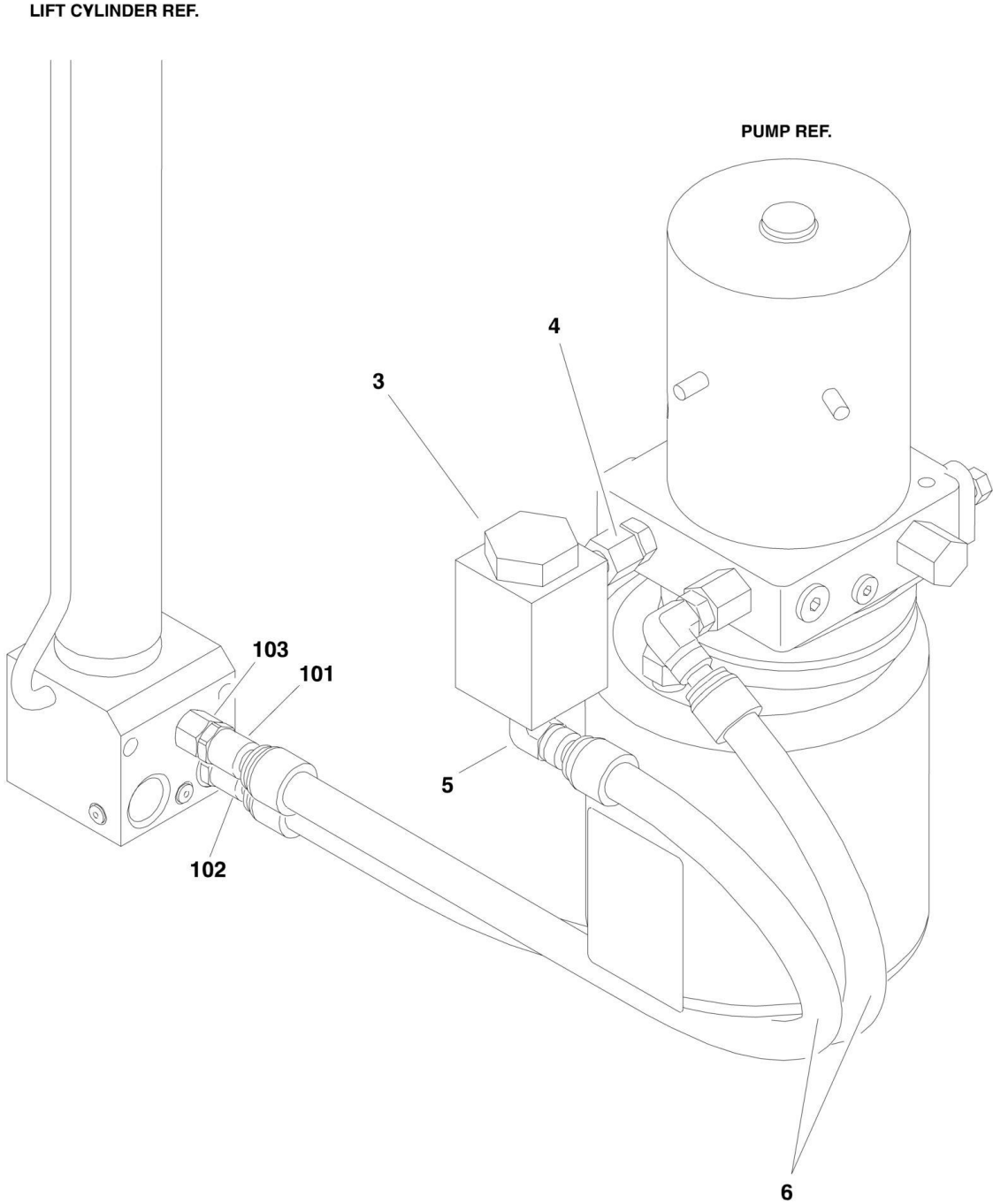

SECTION 6 - HYDRAULIC

FIGURE 6-1. HYDRAULIC DIAGRAM

ITEM	PART NUMBER	QTY	DESCRIPTION	REV
		Ref	HYDRAULIC SYSTEM INSTALLATION	
	0273546	Ref	Standard Hydraulic Oil	E
	0274181	Ref	Fire Resistant Hydraulic Oil	A
3	2120183	1	Filter, In-Line	
4	2221123	1	Fitting, Straight	
5	2221185	1	Fitting, Elbow	
6	2754025	2	Hose	
		Ref	CYLINDER FITTINGS OPTIONS:	
	1684348	Ref	Cylinder Fittings Options (Use p/n 1684531) (Prior to SN 0130011099)	H
	1684531	Ref	Cylinder Fittings Options (SN 0130011099 through 0130032506)	A
101	2221173	1	Fitting, Straight Push Coupling	
102	2221172	1	Fitting, Straight Push Coupling	
103	2220591	1	Fitting, Reducer	
		Ref	TOOLS	
	7027247	1	Tool, Perma-Push Insert Disconnect (Not Shown)	

SECTION 7 - ELECTRICAL

SECTION 7 - ELECTRICAL

FIGURE 7-1. ELECTRICAL COMPONENTS INSTALLATION

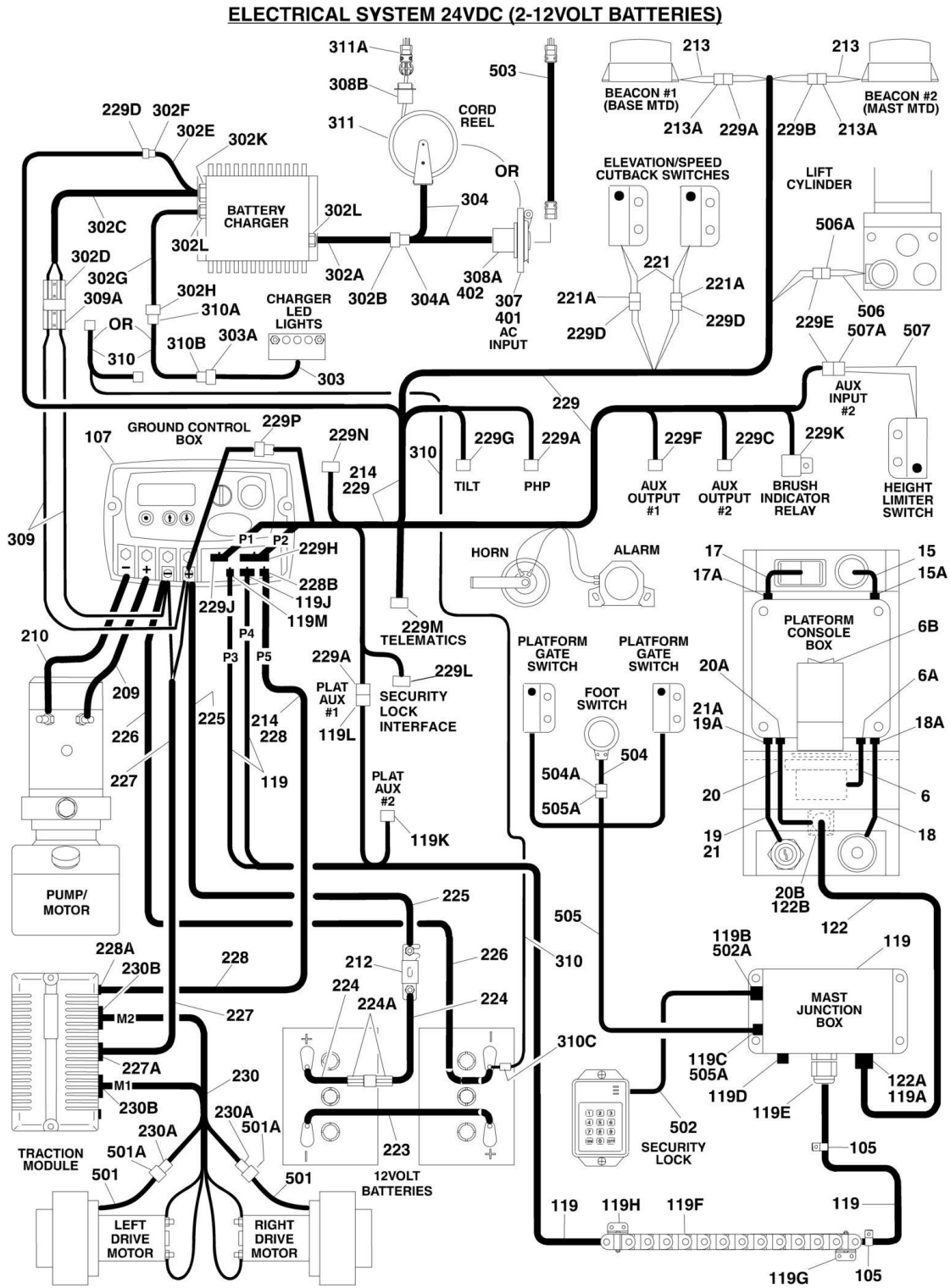

ELECTRICAL SYSTEM 24VDC (4-6VOLT BATTERIES)

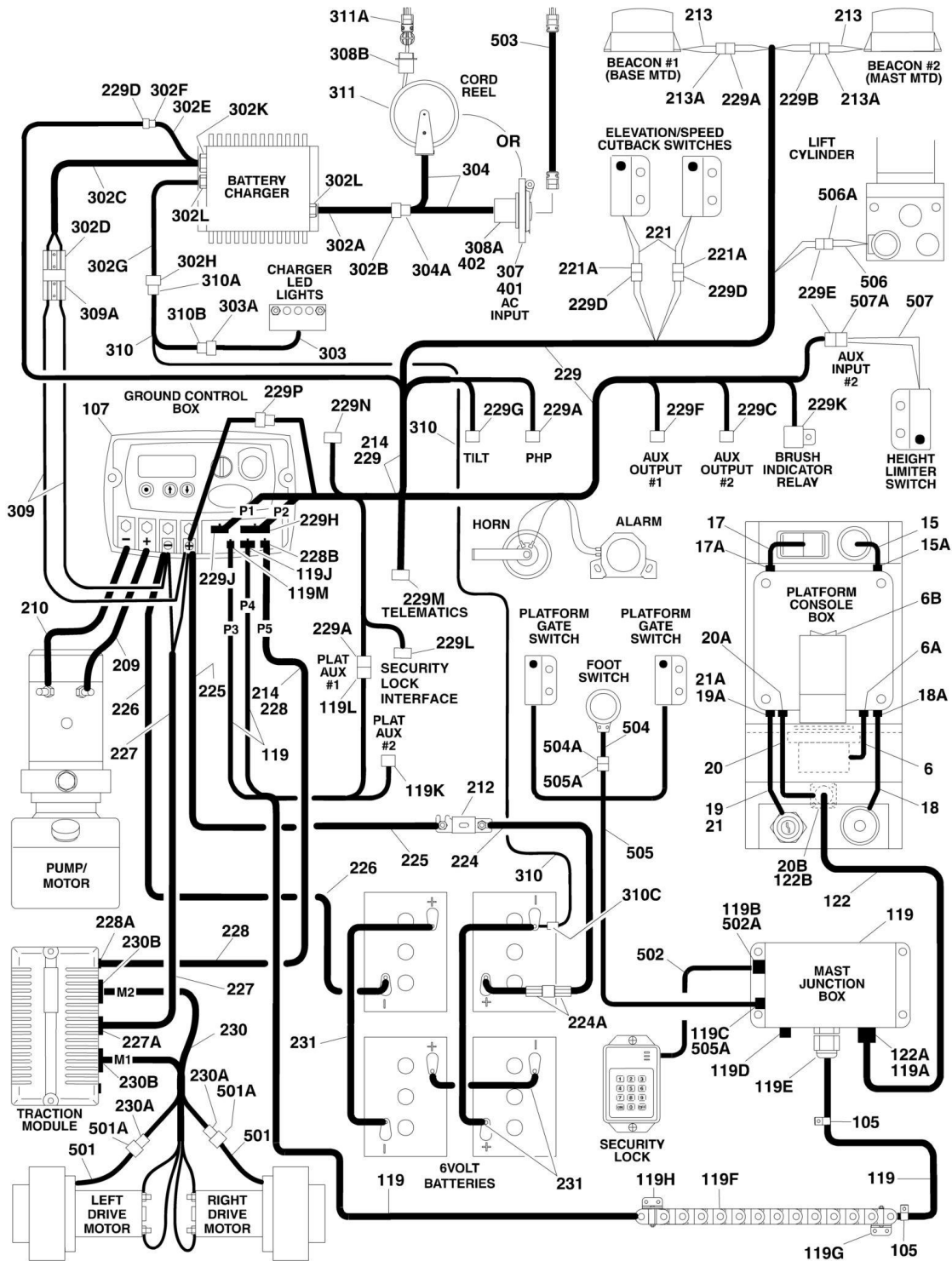

SECTION 7 - ELECTRICAL

FIGURE 7-1. ELECTRICAL COMPONENTS INSTALLATION

ITEM	PART NUMBER	QTY	DESCRIPTION	REV
		Ref	PLATFORM CONTROL BOX COMPONENTS	
	0861768	Ref	Platform Control Box Assembly (All Specs) (Prior to SN 0130010761)	C
	1001098194	Ref	Platform Control Box Assembly (All Specs) (SN 0130010761 through 0130032506)	A
	0861768	Ref	Platform Control Box Assembly (Australian Specs) (Prior to SN 0130010761)	C
	1001098194	Ref	Platform Control Box Assembly (Australian Specs) (SN 0130010761 through 0130017844)	A
	1001137011	Ref	Australian Spec (SN 0130017845 through 0130032506)	A
6	See Note	1	Controller Harness (Note: Not Available for Purchase)	B
6A	250201	1	Connector - 10 Position	
6A	4461023	9	Socket, Female	
6B	7027366	1	Microswitch Harness	
15	4360567	1	Horn Harness (Includes Horn)	B
15A	250206	1	Connector - 2 Position	
15A	4461023	2	Socket, Female	
17	4923106	1	Drive/Lift Select Harness	B
17A	250200	1	Connector - 6 Position	
17A	4461023	3	Socket, Female	
18	4923107	1	Emergency Stop Harness	A
18A	250206	1	Connector - 2 Position	
18A	4461023	2	Socket, Female	
19	4923108	1	Keypad Harness (All Specs) (Prior to SN 0130032506)	A
19	4923108	1	Keypad Harness (Australian Specs) (Prior to SN 0130017845)	A
19A	250206	1	Connector - 2 Position	
19A	4461023	2	Socket, Female	
20	4923315	1	Power Harness	A
20A	4461041	1	Connector - 8 Position	
20A	4461023	6	Socket, Female	
20B	70001798	1	Connector, Female - 9 Position	
20B	70001799	6	Pin, Male	
21	1001137026	1	Keypad Bypass Harness (Australian Spec Only) (SN 0130017845 through 0130032506)	A
21A	See Note	1	Connector - 2 Position (Note: Not Available for Purchase)	
21A	4461023	2	Socket, Female	
		Ref	CABLES AND CONTROLS INSTALLATIONS	
	0273551	Ref	All Specs Except Australian Spec	P
	0273551	Ref	Australian Spec (Prior to SN 0130017845)	P
	1001137012	Ref	Australian Spec (SN 0130017845 through 0130032506)	B
105	1320043	3	Clamp (Prior to SN 0130031692)	
105	1320041	3	Clamp (SN 0130031692 through 0130032506)	
107	3020038	AR	Grease, Contact	
119	4923035	1	Mast Harness	H
119	1060927	15.5 ft/4.7m	Cable, Electrical - 18/12	
119A	7023498	1	Connector, Female - 9 Position	
119A	70001705	6	Pin, Male	
119B	70000344	1	Connector, Female - 4 Position	
119B	4461025	4	Pin, Male	
119C	4460424	1	Connector, Female - 2 Position	

SECTION 7 - ELECTRICAL

ITEM	PART NUMBER	QTY	DESCRIPTION	REV
119C	4460226	2	Socket, Female	
119D	4460424	1	Connector, Female - 2 Position	
119D	4460267	2	Pin, Male	
119E	4460663	1	Connector, Strain Relief	
119F	1180392	1	Carrier, Power Track	
119F	7027734	AR	Link, Repair	
119G	7027736	1	Foot, Mounting (End #1 - Closest to Junction Box)	
119H	7027735	1	Foot, Mounting (End #2 - Furthest From Junction Box)	
119J	250201	1	Connector - 10 Position	
119J	4461023	7	Socket, Female	
119K	4460320	1	Connector - 2 Position	
119K	4460226	2	Socket, Female	
119L	4460320	1	Connector - 2 Position	
119L	4460267	2	Pin, Male	
119M	250199	1	Connector - 4 Position	
119M	4461023	2	Socket, Female	
122	4923316	1	Platform Harness	B
122A	70001703	1	Connector - 9 Position	
122A	70001704	1	Backshell	
122A	70001705	6	Socket, Female	
122B	70001706	1	Connector - 9 Position	
122B	70001707	1	Backshell	
122B	70001708	6	Socket, Female	
		Ref	ELECTRICAL SYSTEM INSTALLATIONS	
	0274896	Ref	2 - 12Volt Batteries System	F
	1001120444	Ref	4 - 6Volt Batteries System	G
209	1060943	1	Cable, Electrical (Ground Control + to Pump +)	
210	1060944	1	Cable, Electrical (Ground Control - to Pump -)	
212	2400069	1	Fuse 175 Amp	
213	2920178	2	Strobe Light Harness (Includes Strobe Light) (Prior to SN 0130021936)	
213	1001187862	1	Strobe Light Harness (Includes Strobe Light) (SN 0130021936 through 0130032506)	
213A	4460320	2	Connector - 2 Position	
213A	4460226	4	Socket, Female	
214	3020038	AR	Grease, Contact	
221	4360514	2	Proximity Harness (Includes Switch)	A
221A	4460424	1	Connector - 2 Position	
221A	4460227	2	Pin, Male	
223	4923021	1	Cable, Battery (B+ to B-) (2 - 12Volt Batteries System Only)	B
223	See Note	1	Boot, Red (Note: Not Available for Purchase)	
223	See Note	1	Boot, Red (Note: Not Available for Purchase)	
224	4923022	1	Cable, Battery (B+ to Fuse)	B
224	See Note	2	Boot, Red (Note: Not Available for Purchase)	
224A	4460216	2	Connector, Anderson (Blue)	
225	4923023	1	Cable, Battery (Fuse to Ground Control +)	A
225	See Note	2	Boot, Red (Note: Not Available for Purchase)	
226	4923024	1	Cable, Battery (B- to Ground Control -)	A
226	See Note	2	Boot, Black (Note: Not Available for Purchase)	
227	4923028	1	Traction Module Power Harness	C
227A	4923028	1	Connector - 2 Position	
228	4923029	1	Ground Control to Traction Module Harness	A

SECTION 7 - ELECTRICAL

ITEM	PART NUMBER	QTY	DESCRIPTION	REV
228A	4923029	1	Connector - 6 Position	
228B	4923029	1	Connector - 6 Position	
229	4923446	1	Main Harness	E
229A	4460424	3	Connector - 2 Position	
229A	4460227	6	Pin, Male	
229B	4460424	1	Connector - 2 Position	
229B	4460267	2	Pin, Male	
229C	4460424	1	Connector - 2 Position	
229C	4460227	1	Pin, Male	
229C	4460226	1	Socket, Female	
229D	4460320	3	Connector - 2 Position	
229D	4460226	6	Socket, Female	
229E	4460320	2	Connector - 2 Position	
229E	4460227	4	Pin, Male	
229F	4460320	1	Connector - 2 Position	
229F	4460227	1	Pin, Male	
229F	4460226	1	Socket, Female	
229G	4460445	1	Connector - 3 Position	
229G	4460227	3	Pin, Male	
229H	4460919	1	Connector - 20 Position	
229H	4460672	19	Socket, Female	
229J	4460920	1	Connector - 14 Position	
229J	4460672	14	Socket, Female	
229K	3740069	1	Relay	
229K	3990010	2	Diode 6A/600V	
229L	1001197889	1	Connector - 4 Position	
229L	1001118156	3	Terminal	
229M	4460884	1	Plug, Male - 4 Position	
229M	4460465	4	Socket, Female	
229M	1001192401	1	Cap, Dust	
229N	250199	1	Connector - 4 Position	
229N	4460672	3	Terminal, Female	
229P	2400060	1	Fusholder with Cover	
229P	8229242	1	Fuse 5 Amp	
230	4933346	1	Drive Motor/Brake Electrical Diagram	D
230	4923383	1	Drive Motor/Brake Harness	E
230A	4460897	2	Connector - 2 Position	
230A	4460464	4	Pin, Male	
230B	4461108	2	Connector - 4 Position	
231	1001121700	3	Cable, Battery (B+ to B -) (4 - 6Volt Batteries System Only)	A
231	See Note	2	Boot, Black (Note: Not Available for Purchase)	
		Ref	BATTERY CHARGER INSTALLATIONS	
	0274897	Ref	Charger with ANSI Plug (Prior to SN 0130010886)	C
	0274900	Ref	Charger with ANSI Plug/Cord Reel	D
	0274899	Ref	Charger without Plug (Prior to SN 0130010886)	C
	0274898	Ref	Charger without Plug	D
302		Ref	Battery Charger Components	
302A	See Note	1	AC Cord (Note: Not Available for Purchase)	
302B	See Note	1	Receptacle, Female (Note: Not Available for Purchase)	
302C	See Note	1	DC Harness (Note: Not Available for Purchase)	
302D	4460648	1	Connector, Anderson	

SECTION 7 - ELECTRICAL

ITEM	PART NUMBER	QTY	DESCRIPTION	REV
302E	See Note	1	Enable Harness (Note: Not Available for Purchase)	
302F	4460424	1	Connector, Male - 2 Position	
302F	4460267	2	Pin, Male	
302G	7022920	1	LED Board Connector Harness	
302H	4460899	1	Connector - 6 Position	
302H	4460464	4	Pin, Male	
302H	4460466	2	Seal	
302K	See Note	1	Connector, Strain Relief (Note: Not Available for Purchase)	
302L	See Note	1	Connector, Strain Relief (Note: Not Available for Purchase)	
303	0610131	1	Charger LED Harness (Includes PC Board)	E
303A	4460321	1	Connector - 4 Position	
303A	4460226	4	Socket, Female	
304	1060689	1	AC Extension Cord	A
304A	1060689	1	Plug, Male	
307		Ref	Cover, Terminal Options: (Prior to SN 0130010886)	
307	4460802	1	Charger with Plug (Prior to SN 0130010886)	
307	4460802	1	Charger without Plug (Prior to SN 0130010886)	
307	Not Required	0	Charger with Plug/Cord Reel (Prior to SN 0130010886)	
308		Ref	Terminal, Inlet Options:	
308A	4460803	1	Charger with ANSI Plug (Prior to SN 0130010886)	
308A	4460940	1	Charger with Australian Plug (Prior to SN 0130010886)	
308A	Not Required	0	Charger without Plug (Prior to SN 0130010886)	
308B	4120046	1	Socket, Cord Reel Stop (Charger with ANSI Plug/Cord Reel Only)	
309	4923438	1	Battery Charger Harness	A
309A	4460648	1	Connector, Anderson	
310		Ref	Charger LED Extension Harness Options:	
310	4923378	1	Charger LED Extension Harness (Prior to SN 0130013545)	B
310	1001109821	1	Charger LED Extension Harness (SN 0130013545 through 0130032506)	A
310A	4460894	1	Connector - 6 Position	
310A	4460465	4	Socket, Female	
310B	4460761	1	Connector - 4 Position	
310B	4460226	4	Socket, Female	
310C	1001102771	1	Sensor (SN 0130013545 through 0130032506)	
311	3680057	1	Cord Reel (Charger with ANSI Plug/Cord Reel Only)	
311A	3680057	1	Plug, Male	
		Ref	AC CHARGER PLUG INSTALLATIONS	
	1001097449	Ref	Charger Plug 110V (ANSI/ANSI Export/CSA/Japanese Spec)	B
	1001097450	Ref	Charger Plug 220V Post Ground (CE Spec)	C
	1001097451	Ref	Charger Plug 220V Side Ground (CE Spec)	B
	1001097452	Ref	Charger Plug 220V Keyed Ground (CE Spec)	B
	1001097453	Ref	Charger Plug 110V IEC 60309 Yellow (CE Spec)	B
	1001097454	Ref	Charger Plug 110V IEC 60309 Blue (CE Spec)	B
	1001097455	Ref	Charger Plug 220V (Australian Spec)	B
	1001097456	Ref	Charger Plug No Plug (ANSI Export /CE Spec)	B
401		Ref	Cover, Terminal Options:	
401	4460802	1	1001097449 / 1001097455 / 1001097456 Installations	
401	Not Required	0	1001097450 / 1001097451 / 1001097452 / 1001097453 / 1001097454 Installations	
402		Ref	Terminal, Inlet Options:	
402	4460803	1	1001097449 Installation	

SECTION 7 - ELECTRICAL

ITEM	PART NUMBER	QTY	DESCRIPTION	REV
402	4461202	1	1001097450 Installation (Prior to SN 0130027713)	
402	4461205	1	1001097450 Installation (SN 0130027713 through 0130032506)	
402	4461205	1	1001097451 Installation	
402	4461249	1	1001097452 Installation	
402	4461196	1	1001097453 Installation	
402	4461199	1	1001097454 Installation	
402	4460940	1	1001097455 Installation	
402	Not Required	0	1001097456 Installation	
		Ref	MISCELLANEOUS HARNESS COMPONENTS	
501	See Note	2	Motor/Brake Harness (Note: Not Available for Purchase)	
501A	4460891	2	Connector - 2 Position	
501A	4460465	4	Socket, Female	
502	2940161	1	Security Lock Harness (Optional)	
502A	250199	1	Connector - 4 Position	
502A	4461023	4	Socket, Female	
503	4923174	1	Extension Cord (Optional)	
504	4360572	1	Footswitch Harness (Includes Switch)	
504A	4460424	1	Connector - 2 Position	
504A	4460226	2	Socket, Female	
505	4360573	1	Platform Gate Switch and Footswitch Harness	
505A	4460320	2	Connector - 2 Position	
505A	4460267	4	Pin, Male	
506	See Note	1	Manual Descent (Lift Cylinder) Harness (Note: Not Available - Purchase Replacement Coil - See CYLINDER SECTION for Breakdown)	
506A	4460424	1	Connector - 2 Position	
506A	4460226	2	Socket, Female	
507	4360515	1	Height Limiter Harness (Includes Switch)	
507A	4460424	1	Connector - 2 Position	
507A	4460226	2	Socket, Female	
		Ref	TOOLS (NOT SHOWN)	
601	7002821	Ref	Crimper (For Wire to Pin/Socket Connections)	
602	7002828	1	Stripper, Wire	
606	7002842	1	Brake Crimp Removal Tool (Not Shown)	
607	7002841	1	Motor Crimp Removal Tool (Not Shown)	
608	7016618	1	Molex Tool (For Ground Control Station Electrical Connectors)	
609	7002841	1	Intech Tool (For Drive Motor Electrical Connectors)	
610	7002842	1	Intech Tool (For Drive Motor Brake Electrical Connectors)	
611	7002847	1	Tyco/AMP Electronics Tool (For other General Electrical Connectors)	
612	7002848	1	Tyco/AMP Electronics Tool (For other General Electrical Connectors)	

SECTION 8 - DECALS

SECTION 8 - DECALS

FIGURE 8-1. DECAL INSTALLATION

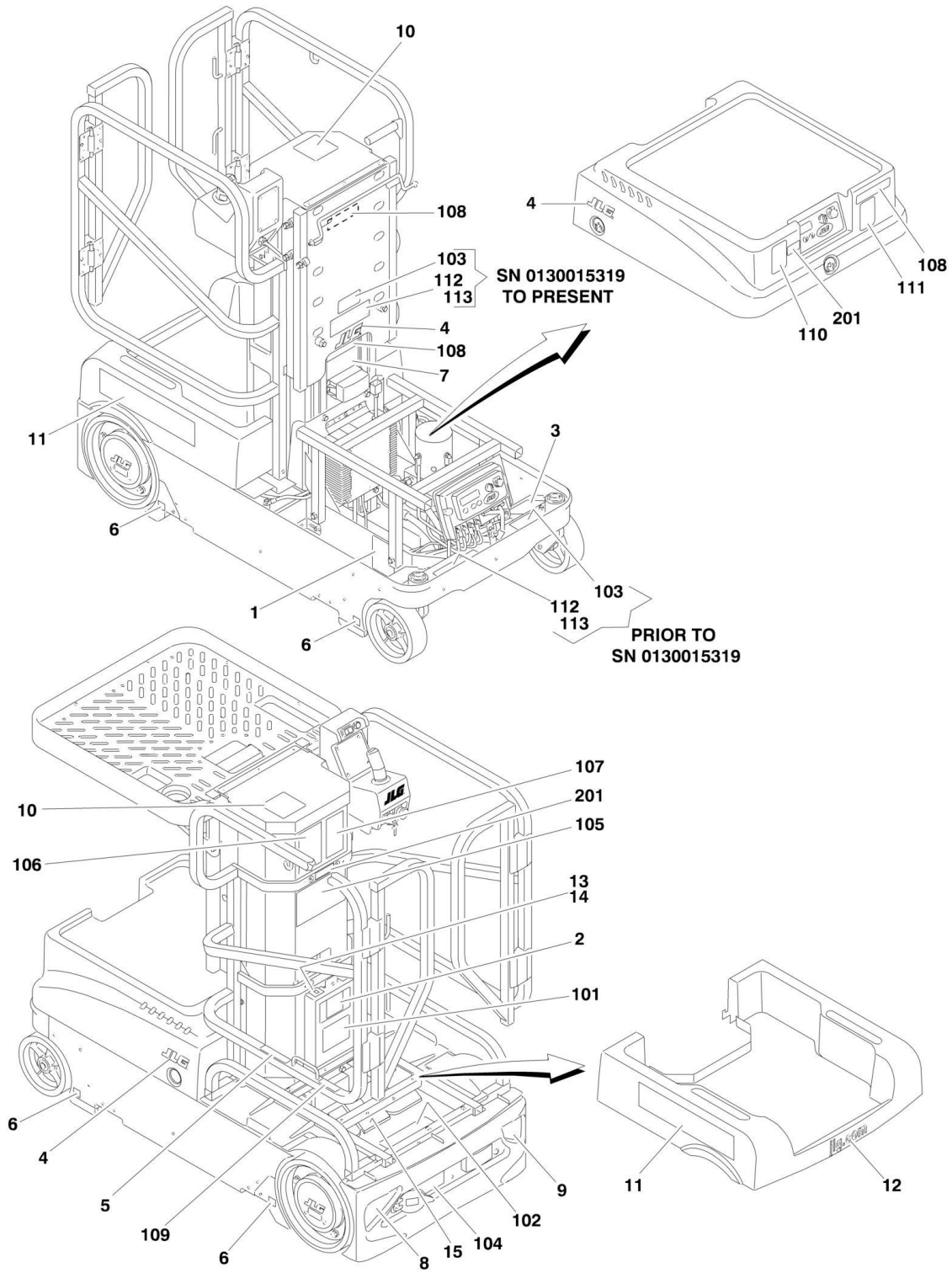

SECTION 8 - DECALS

FIGURE 8-1. DECAL INSTALLATION

ITEM	PART NUMBER	QTY	DESCRIPTION	REV
	0274935	Ref	COMMON DECALS INSTALLATION	G
1	1700584	1	Decal - Patent (Prior to SN 0130016814)	
2	1701640	1	Decal - Manual	
3	See Note	1	Decal - Barcode (Note: Not Available for Purchase)	
4		Ref	Decal - JLG Options:	
4	1703177	3	Decal - JLG (Prior to SN 0130019804)	
4	1703681	3	Decal - JLG (SN 0130019804 through 0130032506)	
5	1705624	1	Decal - Lanyard Attach	
6		Ref	Decal - Wheel Load Options:	
6	1705930	4	Decal - Wheel Load (Prior to SN 0130017845)	
6	1001143557	4	Decal - Wheel Load (SN 0130017845 through 0130032506)	
7	1705992	1	Decal - Manual Descent	
8	1705994	1	Decal - Taillight Reflector (Right) (Prior to SN 0130008828)	
9	1705996	1	Decal - Taillight Reflector (Left) (Prior to SN 0130008828)	
10	1706131	1	Decal - Danger	
11	1706743	2	Decal - Sumo Supermotor 10MSP	
12	1706764	1	Decal - jlg.com Website	
13	3820032	4	Rivet	
14	8990147	1	Holder, Manual	
14	70003486	2	Clip, Manual Holder	
15	1702773	1	Decal - JLG (SN 0130022109 through 0130022207)	
		Ref	COUNTRY SPEC DECALS INSTALLATION	
	0275130	Ref	ANSI Spec (English Language)	E
	0275135	Ref	ANSI Export Spec (Chinese Language)	D
	0275130	Ref	ANSI Export Spec (English Language)	E
	0275134	Ref	ANSI Export Spec (Portuguese Language)	D
	0275133	Ref	ANSI Export Spec (Spanish Language)	D
	0275136	Ref	Australian Spec	D
	0275132	Ref	CE Spec (All Languages)	D
	0275130	Ref	CSA Spec (English Language)	E
	0275131	Ref	CSA Spec (French Language)	E
	0275137	Ref	Japanese Spec	C
101	1703779	1	Decal - USA (ANSI, ANSI Export and CSA English Language Spec Only)	
102		Ref	Decal - Crushing Hazard Options:	
102	1703786	1	ANSI Spec (English Language)	
102	1706090	1	ANSI Spec (Chinese Language)	
102	1703786	1	ANSI Export Spec (English Language)	
102	1706086	1	ANSI Spec (Portuguese Language)	
102	1706082	1	ANSI Spec (Spanish Language)	
102	1705099	1	Australian Spec	
102	1705099	1	CE Spec (All Languages)	
102	1703786	1	CSA Spec (English Language)	
102	1706094	1	CSA Spec (French Language)	
102	1705099	1	Japanese Spec	
103		Ref	Decal - CSA Options:	
103	1705303	1	CSA Spec Only	
103	Not Required	0	All Specs Except CE Spec	
104		Ref	Decal - Battery Charging Instructions Options:	
104	1705929	1	ANSI Spec (English Language)	

SECTION 8 - DECALS

ITEM	PART NUMBER	QTY	DESCRIPTION	REV
104	1706093	1	ANSI Spec (Chinese Language)	
104	1705929	1	ANSI Export Spec (English Language)	
104	1706089	1	ANSI Spec (Portuguese Language)	
104	1706085	1	ANSI Spec (Spanish Language)	
104	1706077	1	Australian Spec	
104	1706077	1	CE Spec (All Languages)	
104	1705929	1	CSA Spec (English Language)	
104	1706097	1	CSA Spec (French Language)	
104	1706077	1	Japanese Spec	
105		Ref	Decal - Warning Options:	
105	1705937	1	ANSI Spec (English Language)	
105	1706092	1	ANSI Spec (Chinese Language)	
105	1705937	1	ANSI Export Spec (English Language)	
105	1706088	1	ANSI Spec (Portuguese Language)	
105	1706084	1	ANSI Spec (Spanish Language)	
105	Not Required	0	Australian Spec	
105	Not Required	0	CE Spec (All Languages)	
105	1705937	1	CSA Spec (English Language)	
105	1706096	1	CSA Spec (French Language)	
105	Not Required	0	Japanese Spec	
106		Ref	Decal - Danger Options:	
106	1705938	1	ANSI Spec (English Language)	
106	1706091	1	ANSI Spec (Chinese Language)	
106	1705938	1	ANSI Export Spec (English Language)	
106	1706087	1	ANSI Spec (Portuguese Language)	
106	1706083	1	ANSI Spec (Spanish Language)	
106	1706078	1	Australian Spec	
106	1706078	1	CE Spec (All Languages)	
106	1705938	1	CSA Spec (English Language)	
106	1706095	1	CSA Spec (French Language)	
106	1706078	1	Japanese Spec	
107		Ref	Decal - Capacity Options:	
107	1705939	1	ANSI, ANSI Export and CSA Specs	
107	1706079	1	Australian, CE and Japanese CE Specs	
108		Ref	Decal - Crushing Hazard Options:	
108	1705995	3	ANSI Spec (English Language)	
108	1706090	3	ANSI Spec (Chinese Language)	
108	1705995	3	ANSI Export Spec (English Language)	
108	1706086	3	ANSI Spec (Portuguese Language)	
108	1706082	3	ANSI Spec (Spanish Language)	
108	1705099	3	Australian Spec	
108	1705099	3	CE Spec (All Languages)	
108	1705995	3	CSA Spec (English Language)	
108	1706094	3	CSA Spec (French Language)	
108	1705099	3	Japanese Spec	
109		Ref	Decal - Fall Restraint Options:	
109	1706115	1	ANSI Spec (English Language)	
109	1706117	1	ANSI Spec (Chinese Language)	
109	1706115	1	ANSI Export Spec (English Language)	
109	1706118	1	ANSI Spec (Portuguese Language)	
109	1706116	1	ANSI Spec (Spanish Language)	

SECTION 8 - DECALS

ITEM	PART NUMBER	QTY	DESCRIPTION	REV
109	Not Required	0	Australian Spec	
109	Not Required	0	CE Spec (All Languages)	
109	1706115	1	CSA Spec (English Language)	
109	1706119	1	CSA Spec (French Language)	
109	Not Required	0	Japanese Spec	
110	1706616	1	Decal - Capacity	
111	1706617	1	Decal - No Riders	
112	2080057	4	Fastener	
113	See Note	1	Nameplate - Serial Number (Note: Not Available for Purchase)	
114		Ref	Decal - Patent Options: (SN 0130016814 through 0130032506)	
114	1001131273	1	ANSI, ANSI Export (English Language) and CSA Spec Only	
114	Not Required	0	All Specs Except ANSI, ANSI Export (English Language) and CSA Spec	
		Ref	SERVICE DECAL INSTALLATION (OPTIONAL)	
	0274568	Ref	Decal - Alternative Service (Target Specs)	C
	0275923	Ref	Decal - Alternative Service (Sears Specs) (Use p/n 0274568)	C
201		Ref	Decal - Alternative Service	
201	See Note	1	Decal - Service Support: 1-877-523-3374 (Use p/n 1001110242)	
201	See Note	1	Decal - Service Support: 1-877-554-2112 (Sears Specs) (Use p/n 1001110242)	
		Ref	Note: Illustration shows (2) #201 call-outs because location may vary.	

SECTION 9 - RECOMMENDED SERVICE PARTS STOCK

SECTION 9 - RECOMMENDED SERVICE PARTS STOCK

SECTION 9 - RECOMMENDED SERVICE PARTS STOCK

FIGURE 9-1. 10MSP SERVICE PARTS

ITEM	PART NUMBER	QTY	DESCRIPTION	REV
	Note	Ref	Note: The following list will service one machine (built to current production per date on the front cover) with emergency repair parts which can be installed in the field. Parts from the list should be replaced when inventory is depleted to keep service parts stock supplied. For further information, contact your JLG dealer or the JLG Industries Parts Department.	
		Ref	STANDARD PARTS	
	7011069	1	Breather	
	2400069	2	Fuse 175 Amp	
	4360514	1	Proximity Switch	
	7024428	1	Emergency Stop Switch	
	7024430	1	Selector Switch	
	1001098192	1	Controller Assembly	
	4360467	1	Keyswitch	
	2860030	1	Key, Replacement	
	4360562	1	Switch, Emergency	
	4360567	1	Switch, Push Button	
	4360581	1	Switch, Rocker	
	4360572	1	Footswitch	
	4360573	1	Proximity Switch	
	2120183	4	Filter, In-Line	
	7027734	1	Carrier Power Track Repair Link	
	3740069	1	Relay	
	3990010	2	Diode	
		Ref	VARIABLE PARTS	
	4360515	1	Switch, Proximity (Machines with Height Limiter)	
	1600451	1	Traction Module	
	1600435	1	Ground Control Module (All Specs except Australian, Japanese & Chinese Specs)	
	1001136954	1	Ground Control Module (Australian Spec)	
	1600436	1	Ground Control Module (Japanese & Chinese Specs)	
	1600378	1	Platform Module	

SECTION 10 - SPECIAL OPTIONS

SECTION 10 - SPECIAL OPTIONS

FIGURE 10-1. SPECIAL OPTIONS

ITEM	PART NUMBER	QTY	DESCRIPTION	REV
	Note	Ref	Note: This list is to accomodate machines ordered with special equipment. Options may not be applicable to all models. For more specific parts information contact JLG Parts Department.	
		Ref	MISCELLANEOUS SPECIAL OPTIONS	
	1001127560	Ref	Battery Conversion Kit (Converts (2) 12Volt battery system to (4) 6Volt battery system)	
	1001091680	Ref	Cargo Strap Installation	
	1001229107	Ref	ClearSky Telematics 3 Wire Installation (Factory Installed)	
		Ref	Decals Installations	
	1001229710	Ref	Decal - Clear Sky	
	1001214031	Ref	Decal - EAC (Russian/CIS Specs)	
	0274053	Ref	Decal - Target	
		Ref	Electrical Connector Kits	
	1001148902	Ref	Amp Connector Kit	
	1001148903	Ref	Deutsch DT Connector Kit	
	1001148904	Ref	Deutsch HD Connector Kit	
	1001148905	Ref	Packard Connector Kit	
	1001148906	Ref	Various Connector Kit	
	1001222318	Ref	Floor Mat Installation	
	1001112957	Ref	Gate Alarm Installation	
	0240112	Ref	Scanner Pocket	
	1580031	1	Pocket, Scanner	
	4341005	1	Mount, Pocket	
		Ref	Tools For Service:	
	7002821	1	Crimper (For Wire to Pin/Socket Connections)	
	7002823	1	Extractor (For Removal of Pin/Sockets Connectors)	
	4460467	1	Extractor 16-18 Gauge (For Wire to Pin/Socket from Deutsch Connectors)	
	4460510	1	Extractor 12-14 Gauge (For Wire to Pin/Socket from Deutsch Connectors)	
	7016654	1	Screwdriver, Magnetic	
	7004275	1	Seal Tool - 1in	
	7004276	1	Seal Tool - 1 1/2in	
	7002826	1	Seal Tool 2in	
	8896941	1	Stripper, Wire	
	2915027	1	Rear Wheel Puller	
	7002842	1	Brake Crimp Removal Tool (Not Shown)	
	7002841	1	Motor Crimp Removal Tool (Not Shown)	
	7016618	1	Molex Tool (For Ground Control Station Electrical Connectors)	
	7002841	1	Intech Tool (For Drive Motor Electrical Connectors)	
	7002842	1	Intech Tool (For Drive Motor Brake Electrical Connectors)	
	7002847	1	Tyco / AMP Electronics Tool (For other General Electrical Connectors)	
	7002848	1	Tyco / AMP Electronics Tool (For other General Electrical Connectors)	
	7027247	1	Perma-Push insert Disconnect Tool (For Hydraulic Fittings)	
	3125081	NLA	Video, Operators (Use p/n 31201384)	

PART NUMBER INDEX

PART NUMBER INDEX

0100011.....11, 12, 17, 19, 24, 27, 29, 34, 37, 39, 41, 45, 49, 51, 53, 55, 57, 59	0630464 41	1001098810 11	1001229107.....94
0100019.....46, 57, 59	0630580 11	1001099638 51, 55	1001229710.....94
0100051.....34	0641404 34, 37	1001100141 53, 55	1060380.....65
0100062.....46	0641406 39	1001100142 53, 55	1060689.....27, 29, 83
0100081.....11	0641408 11, 35	1001100634 53, 55	1060799.....61
0140022.....34	0641410 65	1001100840 11	1060927.....80
0140033.....37	0641412 39	1001101529 53, 55	1060943.....81
0240103.....12	0641413 11	1001102771 83	1060944.....81
0240107.....63	0641415 53, 55	1001102847 37	1120582.....49, 51, 53, 55
0240108.....63	0641416 49, 51, 53, 55	1001102932 29	1120583.....49, 51, 53, 55
0240109.....63	0641424 61	1001109821 83	1180392.....81
0240112.....94	0641606 12, 24	1001112957 94	1260375.....45, 46
0240114.....17, 19	0641609 11, 12, 46	1001114467 11	1260376.....45, 46
0255040.....65	0641612 46	1001116792 39	1271567.....45
0273417.....46	0641613 59	1001118156 82	1271568.....45
0273545.....46	0641616 51, 55	1001120444 34, 81	1271569.....45
0273546.....24, 75	0641617 12, 17, 19	1001120445 35	1271577.....45
0273551.....39, 80	0641618 61	1001120531 17, 19	1320041.....39, 80
0273566.....39	0641622 49, 53	1001121648 17, 19	1320043.....39, 80
0273570.....61	0681414 51, 55	1001121700 82	1320149.....39
0273571.....61	0721003 39	1001127560 94	1320316.....61
0274011.....57	0721004 29	1001129506 35	1321283.....39
0274053.....94	0721006 45	1001131273 89	1380169.....17, 19
0274055.....49	0741003 39	1001136380 34	1580027.....57
0274078.....11	0741005 34	1001136381 29	1580031.....94
0274181.....24, 75	0741412 39	1001136954 37, 92	1600378.....41, 92
0274568.....89	0741614 49, 51, 53, 55	1001137011 39, 41, 80	1600379.....41
0274893.....11	0751003 49, 51, 53, 55	1001137012 39, 80	1600397.....37
0274894.....37	0751006 49	1001137013 37	1600435.....37, 92
0274895.....37	0791003 34, 39, 45	1001137026 80	1600436.....37, 92
0274896.....34, 81	0791404 41	1001137484 41	1600451.....37, 92
0274897.....27, 82	0791406 27, 29, 34, 63	1001143557 87	1600454.....41
0274898.....27, 29, 82	0791508 27, 29	1001148752 53	1600466.....27, 30
0274899.....27, 82	0791812 45	1001148753 53, 55	1671141.....17
0274900.....27, 29, 82	0801394 45	1001148754 53, 55	1671143.....17, 19
0274901.....17	0811408 45	1001148902 94	1671146.....17, 19
0274904.....11	0811610 17, 19, 57, 59	1001148903 94	1671168.....49, 53
0274935.....87	0861767 41	1001148904 94	1671298.....17, 19
0275130.....87	0861768 39, 41, 80	1001148905 94	1684348.....45, 69, 75
0275131.....87	0902047 45	1001148906 94	1684531.....45, 71, 75
0275132.....87	0902423 45	1001149003 53	1700584.....87
0275133.....87	0902424 45	1001171828 51, 55	1701640.....87
0275134.....87	0902431 45	1001171840 51, 55	1702365.....65
0275135.....87	0902445 45	1001171844 51	1702773.....87
0275136.....87	0902698 45	1001171846 59	1703177.....87
0275137.....87	0902895 61	1001171847 59	1703681.....87
0275901.....35	0903120 12	1001171855 59	1703779.....87
0275923.....89	0903121 12	1001171856 59	1703786.....87
0362735.....45	0903222 17, 19	1001171857 59	1704412.....24
0400209.....34	0903671 35	1001171858 19	1705099.....87, 88
0400241.....27, 29	0940049 17, 19, 51, 55	1001171869 59	1705303.....87
0440246.....45	0940132 11	1001171916 51	1705624.....87
0440249.....45	0940152 11	1001174513 55	1705929.....87, 88
0440287.....57	0940153 11	1001174586 55	1705930.....87
0440306.....11	1001091680 94	1001177558 35	1705937.....88
0440307.....11	1001097449 29, 83	1001181407 59	1705938.....88
0440308.....11	1001097450 29, 83	1001187862 34, 81	1705939.....88
0561149.....46	1001097451 29, 83	1001187868 35	1705992.....87
0561153.....46	1001097452 29, 83	1001187869 35	1705994.....87
0561341.....45	1001097453 29, 83	1001192401 82	1705995.....88
0561408.....46	1001097454 29, 83	1001197889 82	1705996.....87
0561409.....46	1001097455 29, 83	1001204273 11	1706007.....41
0610131.....27, 29, 83	1001097456 29, 83	1001207630 35	1706077.....88
	1001098192 41, 42, 92	1001214031 94	1706078.....88
	1001098193 41	1001222318 94	1706079.....88
	1001098194 39, 41, 80	1001225209 71	1706082.....87, 88

PART NUMBER INDEX

1706083 88	3160323 11, 15	3900187 45	4460424 ... 80, 81, 82, 83,
1706084 88	3271405 11	3900189 41	84
1706085 88	3271601 59	3900192 45	4460428 29
1706086 87, 88	3290401 35	3900205 35	4460445 82
1706087 88	3291007 59	3900258 17, 19, 49, 53	4460464 82, 83
1706088 88	3300151 53, 55	3900264 39	4460465 82, 83, 84
1706089 88	3300381 53, 55	3900283 12	4460466 83
1706090 87, 88	3300454 17, 19	3900373 39	4460467 94
1706091 88	3310601 41	3900393 59	4460510 94
1706092 88	3311001 27, 29	3910608 41	4460648 82, 83
1706093 88	3311005 41	3910804 41	4460663 81
1706094 87, 88	3311405 ... 12, 35, 39, 51,	3911016 27, 29, 30, 34	4460672 82
1706095 88	55, 61, 63, 65	3911020 37	4460761 83
1706096 88	3311408 45, 63	3931408 63	4460802 ... 27, 29, 30, 83
1706097 88	3311501 34	3931420 12	4460803 27, 29, 83
1706115 88, 89	3311601 45, 46	3931456 53, 55	4460884 82
1706116 88	3311605 ... 11, 12, 17, 19,	3960590 11	4460891 84
1706117 88	39, 49, 51, 53, 55, 61	3990010 82, 92	4460894 83
1706118 88	3321701 57	4010412 35	4460897 82
1706119 89	3340845 45	4010414 35	4460899 83
1706131 87	3340962 ... 49, 51, 53, 55,	4070860 45	4460919 82
1706134 61, 63	57, 59	4070861 45	4460920 82
1706326 65	3380540 41	4070862 45	4460940 ... 27, 29, 83, 84
1706616 89	3380541 34	4070970 45	4461023 80, 81, 84
1706617 89	3380771 34	4070971 45	4461025 80
1706743 87	3420198 61	4071084 34, 35	4461041 80
1706764 87	3421453 65	4071095 49, 51, 53, 55	4461108 82
2080040 ... 34, 35, 49, 51,	3422338 46	4071113 11	4461196 30, 84
53, 55, 57, 63	3422346 46	4071114 11	4461199 30, 84
2080043 ... 49, 51, 53, 55	3422355 46	4120046 27, 29, 83	4461202 29, 84
2080057 89	3422717 45	4160124 46	4461205 30, 84
2110606 24	3422744 63	4160130 39	4461249 30, 84
2120183 75, 92	3422750 45	4160187 12	4520281 11
2220591 69, 71, 75	3422752 45	4191406 34, 35	4520326 11
2220883 69	3422757 45	4191706 27, 29	4520342 11
2220886 69	3423171 57	4220222 57	4520343 11
2221123 75	3450302 57, 59	4220233 49	4520352 12
2221172 69, 71, 75	3450304 46	4220234 49	4520565 11
2221173 69, 71, 75	3510860 49, 53	4220309 49, 51, 53, 55	4567491 46
2221185 24, 75	3510862 49, 53	4240018 39	4567750 46
2300014 24	3510865 49	4240033 35	4567751 46
2300021 24	3520072 ... 49, 51, 53, 55	4240147 11	4568208 63
2360684 57	3520176 63	4240163 61	4569003 46
2400044 34	3570893 45	4280296 65	4569158 63
2400060 82	3571101 46	4300111 46	4630009 63
2400069 34, 81, 92	3571103 46	4340838 39	4630010 63
2410012 49, 51	3571584 29	4340884 41	4711000 30
2410013 49, 51	3572511 35	4341005 94	4711400 ... 11, 35, 39, 49,
250199 81, 82, 84	3575423 27, 29, 34	4341067 17	51, 53, 55, 61
250200 80	3580269 45	4341155 11	4711600 ... 11, 17, 19, 46,
250201 80, 81	3580286 45	4360467 41, 92	49, 51, 53, 55, 57, 59,
250206 80	3580293 45	4360514 ... 34, 35, 81, 92	61
2600294 ... 49, 51, 53, 55	3580344 39	4360515 35, 84, 92	4711700 57
2660121 61	3600392 23, 24	4360562 41, 92	4740007 46
2754025 75	3680057 27, 29, 83	4360567 41, 80, 92	4740139 51, 55
280013 53, 55	3740069 82, 92	4360572 ... 49, 51, 53, 55,	4740414 46
2860030 41, 92	3760115 11	84, 92	4740476 57
2880310 45	3760170 65	4360573 ... 49, 51, 53, 55,	4750800 35
2915027 94	3760308 17, 19	84, 92	4751000 37, 39, 46
2920178 34, 81	3760365 17, 19	4360581 41, 92	4751400 ... 12, 17, 19, 35
2940161 39, 84	3760383 45	4460216 81	4751500 ... 17, 19, 27, 29,
2940165 57, 59	3760496 11	4460226 ... 81, 82, 83, 84	39, 46
3020029 11	3820013 35	4460227 81, 82	4761000 29, 35
3020038 80, 81	3820024 35	4460267 ... 81, 82, 83, 84	4761500 34
3020039 11	3820032 34, 87	4460320 ... 51, 55, 81, 82,	4811400 34
3020041 45	3890039 45	84	4811900 59
3125081 94	3900174 17, 19	4460321 83	4812000 59

PART NUMBER INDEX

4844840.....	65	70000686.....	42	7010928.....	23	7026624.....	71
4891400.....	12	70000991.....	71	7011004.....	23	7026625.....	71
4923021.....	81	70000992.....	71	7011008.....	23	7027247.....	75, 94
4923022.....	81	70000993.....	71	7011009.....	23	7027340.....	69
4923023.....	81	70000994.....	71	7011011.....	23	7027365.....	42
4923024.....	81	70000995.....	71	7011013.....	23	7027366.....	80
4923028.....	81	70001113.....	71	7011016.....	23	7027367.....	42
4923029.....	81, 82	70001250.....	42	7011017.....	23	7027733.....	34
4923035.....	39, 80	70001251.....	42	7011021.....	23	7027734.....	81, 92
4923106.....	80	70001252.....	42	7011024.....	23	7027735.....	81
4923107.....	80	70001253.....	42	7011025.....	23	7027736.....	81
4923108.....	80	70001703.....	81	7011027.....	23	7027764.....	42
4923174.....	39, 84	70001704.....	81	7011029.....	23	7027765.....	42
4923315.....	80	70001705.....	80, 81	7011031.....	23	7027766.....	42
4923316.....	39, 81	70001706.....	81	7011032.....	23	7027847.....	69
4923378.....	83	70001707.....	81	7011033.....	23	7027848.....	69
4923383.....	82	70001708.....	81	7011034.....	23	7027849.....	69
4923438.....	83	70001798.....	80	7011069.....	23, 92	7027850.....	69
4923446.....	82	70001799.....	80	7016618.....	84, 94	7027851.....	69
4933346.....	82	70003486.....	87	7016654.....	94	7027852.....	69
70000082.....	42	70003805.....	41	7022920.....	83	7027853.....	69
70000084.....	42	70006451.....	71	7023391.....	71	7027855.....	69
70000191.....	15	70006453.....	71	7023392.....	71	7027943.....	23
70000210.....	15	70006454.....	71	7023395.....	71	7027944.....	23
70000211.....	15	70006455.....	71	7023498.....	80	7027945.....	23
70000212.....	15	7002821.....	84, 94	7024428.....	37, 92	7027946.....	23
70000213.....	15	7002823.....	94	7024430.....	37, 92	7027947.....	23
70000214.....	15	7002826.....	94	7024460.....	37	7027948.....	23
70000215.....	15	7002828.....	84	7024591.....	37	7027949.....	23
70000218.....	71	7002841.....	84, 94	7024592.....	37	8229242.....	82
70000344.....	80	7002842.....	84, 94	7024747.....	15	8882320.....	49, 51, 53, 55
70000682.....	41	7002847.....	84, 94	7024748.....	15	8882970.....	11
70000683.....	42	7002848.....	84, 94	7024756.....	15	8896941.....	94
70000684.....	42	7004275.....	94	7024758.....	15	8990147.....	87
70000685.....	42	7004276.....	94	7026623.....	71		



3121229



An Oshkosh Corporation Company

Corporate Office
JLG Industries, Inc.
1 JLG Drive
McConnellsburg, PA 17233-9533
USA

+1-717-485-5161 (Corporate)
+1-877-554-5438 (Customer Support Toll Free)
+1-717-485-6417

JLG Worldwide Locations

JLG Industries
358 Park Road
Regents Park
NSW 2143
Sydney 2143
Australia
+6 (12) 87186300
+6 (12) 65813058
Email: techservicesaus@jlg.com

JLG Ground Support Oude
Bunders 1034
Breitwaterstraat 12A
3630 Maasmechelen
Belgium
+32 (0)89 84 82 26
Email: emeaservice@jlg.com

JLG Latino Americana LTDA
Rua Antonia Martins Luiz, 580
Distrito Industrial Joao Narezzi
Indaiatuba-SP 13347-404
Brasil
+55 (19) 3936 7664 (Parts)
+55 (19) 3936 9049 (Service)
Email: comercialpecas@jlg.com
Email: servicos@jlg.com

Oshkosh-JLG (Tianjin)
Equipment Technology LTD
Shanghai Branch
No 465 Xiao Nan Road
Feng Xian District
Shanghai 201204
China
+86 (21) 800 819 0050

JLG Industries Dubai
Jafza View
PO Box 262728, LB 19
20th Floor, Office 05
Jebel Ali, Dubai
+971 (0) 4 884 1131
+971 (0) 4 884 7683
Email: emeaservice@jlg.com

JLG France SAS
Z.I. Guillaume Mon Amy
30204 Fauillet
47400 Tonniens
France
+33 (0) 553 84 85 86
+33 (0) 553 84 85 74
Email: pieces@jlg.com

JLG Deutschland GmbH
Max Planck Str. 21
27721 Ritterhude-Ihlpohl
Germany
+49 (0) 421 69350-0
+49 (0) 421 69350-45
Email: german-parts@jlg.com

JLG Equipment Services Ltd.
Rm 1107 Landmark North
39 Lung Sum Avenue
Sheung Shui N. T.
Hong Kong
+(852) 2639 5783
+(852) 2639 5797

JLG Industries (Italia) S. R. L.
Via Po, 22
IT-20010 Pregnana Milanese (MI)
Italy
+39 (0) 2 9359 5210
+39 (0) 2 9359 5211
Email: ricambi@jlg.com

JLG EMEA B.V.
Polaris Avenue 63
2132 JH Hoofdorf
The Netherlands
+31 (0) 23 565 5665
Email: emeaservice@jlg.com

JLG NZ Access Equipment & Services
2B Fisher Crescent
Mt Wellington 1060
Auckland, New Zealand
+6 (12) 87186300
+6 (12) 65813058
Email: techservicesaus@jlg.com

JLG Industries
Vahutinskoe shosse 24b
Khimki,
Moscow Region 141400
Russia Federation
+7 (499) 922 06 99
+7 (499) 922 06 99

Oshkosh-JLG Singapore
Technology Equipment P te Ltd.
35 Tuas Avenue 2
Jurong Industrial Estate
Singapore 639454
+65 6591 9030
+65 6591 9045
Email: SEA@jlg.com

JLG Iberica S. L.
Trapadella, 2
Pol. Ind. Castellbisbal Sur
08755 Castellbisbal
Barcelona
Spain
+34 (0) 93 772 47 00
+34 (0) 93 77 117 62
Email: parts_iberica@jlg.com

JLG Sverige AB
Enkopingsvagen 150
17627 Jarfalla
Sweden
+46 (0) 8 506 595 00
+46 (0) 8 506 595 27
Email: nordicsupport@jlg.com

JLG Industries (UK) Ltd.
Bentley House
Bentley Avenue
Middleton, Greater Manchester
M24 2GP
United Kingdom
+44 (0) 161 654 1000
+44 (0) 161 654 1003
Email: ukparts@jlg.com

www.jlg.com