



***Illustrated Parts Manual
Manuel de pièces détachées***

MODEL / MODELE

TOUCAN 10E

TOUCAN 26E

**PVC
2101**

ANSI

CE



AS/NZS

31210401

July 5, 2021
REV B



An Oshkosh Corporation Company

REVISION LOG

REVISION LOG

January 11, 2021 ----- Original issue of Manual - PVC2101 (Edited to B/M 1001220001 Revision J)
July 5, 2021 ----- Revision B-Add LSS cover (Edited to B/M 1001220001 Revision M)

TABLE OF CONTENTS

SECTION 1 - HOODS INSTALL / INSTALLATION CAPOTS	7
FIGURE 1-1. HOODS INSTALL / INSTALLATION CAPOTS	8
SECTION 2 - FRAME INSTALL / INSTALLATION CHASSIS	13
FIGURE 2-1. FRAME INSTALL / INSTALLATION CHASSIS	14
FIGURE 2-2. STEERING WHEEL HUB / MOYEU ROUE DIRECTRICE	18
FIGURE 2-3. DRIVE GEAR MOTOR / MOTOREDUCTEUR DE ROUE	20
SECTION 3 - MAST 1 INSTALL / INSTALLATION MAT 1	23
FIGURE 3-1. MAST 1 INSTALL / INSTALLATION MAT 1	24
FIGURE 3-2. MTB INSTALL / INSTALLATION COMMANDES BASSES	28
FIGURE 3-3. GROUND CONTROL PANEL WITH ENABLE / BOITIER BAS AVEC VALIDATION	30
FIGURE 3-4. GROUND CONTROL PANEL W/O ENABLE / BOITIER BAS SANS VALIDATION	32
SECTION 4 - MAST AND BOOM INSTALL / INSTALLATION MATS ET BRAS	35
FIGURE 4-1. MAST AND BOOM INSTALL / INSTALLATION MAT ET BRAS	36
FIGURE 4-2. PULLEY SUPPORT LL10-44 / SUPPORT POULIE LL10-44	40
FIGURE 4-3. PULLEY SUPPORT LL12-66 / SUPPORT POULIE LL12-66	42
SECTION 5 - PLATFORM INSTALL / INSTALLATION PLATE-FORME	45
FIGURE 5-1. PLATFORM SUPPORT INSTALL / INSTALLATION SUPPORT PLATE-FORME	46
FIGURE 5-2. PLATFORM,DROP BAR INSTALL / INSTALLATION PLATE-FORME - LISSE COULISSANTE	48
FIGURE 5-3. PLATFORM,SALOON GATES / INSTALLATION PLATE-FORME - PORTE SALOON	50
FIGURE 5-4. SKYLINE INSTALL / INSTALLATION SKYLINE	52
FIGURE 5-5. CONSOLE AND CONTAINER INSTALL / INSTALLATION BOITIER DE COMMANDE ET BOITE A OUTILS	54
FIGURE 5-6. PLATFORM CONSOLE ASSEMBLY / BOITIER HAUT	56
SECTION 6 - POWER TRACKS AND CLAMPS INSTALL / INSTALLATION CHAINES PORTE CABLES	59
FIGURE 6-1. POWER TRACKS AND CLAMPS INSTALL / INSTALLATION CHAINES PORTE CABLES	60
SECTION 7 - HYDRAULIC INSTALL / INSTALLATION HYDRAULIQUE	65
FIGURE 7-1. HOSES KIT DIAGRAM / SCHEMA KIT FLEXIBLES	66
FIGURE 7-2. CONTROL VALVES INSTALL / INSTALLATION DISTRIBUTEURS	68
FIGURE 7-3. TANK AND PUMP INSTALL / INSTALLATION GROUPE HYDRAULIQUE	72
FIGURE 7-4. PUMP-MOTOR-TANK ASSEMBLY / GROUPE HYDRAULIQUE	74
FIGURE 7-5. VALVE ASSY,MAST CYLINDER / ASSEMBLAGE DISTRIBUTEUR VERIN MAT	76
FIGURE 7-6. VALVE ASSY,JIB CYLINDER / ASSEMBLAGE DISTRIBUTEUR VERIN BRAS	78
SECTION 8 - ELECTRICAL SYSTEM INSTALL / INSTALLATION ELECTRIQUE	81
FIGURE 8-1. CABLES AND SWITCHES INSTALL DIAGRAM / DIAGRAMME D'INSTALLATION CABLES ET CAPTEURS	82
FIGURE 8-2. KIT,POWER CABLES / KIT CABLES DE PUISSANCE	88
FIGURE 8-3. BATTERY AND CHARGER INSTALL / INSTALLATION BATTERIES ET CHARGEUR	90
FIGURE 8-4. SWITCHES AND COVERS INSTALL / INSTALLATION CAPTEURS	92
SECTION 9 - DECALS INSTALL / INSTALLATION AUTOCOLLANTS	95
FIGURE 9-1. DECALS ALL PRODUCTS / INSTALLATION TOUT PRODUIT	96
SECTION 10 - OPTIONS / OPTIONS	105
FIGURE 10-1. SKYLINE BEACON INSTALL / INSTALLATION FEU SKYLINE	106
FIGURE 10-2. INSTALL,PEDAL FOR JAPAN / INSTALLATION PEDALE POUR JAPON	108
FIGURE 10-3. MOTION ALARM INSTALL / INSTALLATION ALARME DE MOUVEMENT	110
FIGURE 10-4. 230V PLATFORM SOCKET INSTALL / INSTALLATION PRISE PLATE-FORME 230V	112
FIGURE 10-5. PLATFORM 115V GFI-US SOCKET INSTALL / INSTALLATION PRISE PLATE-FORME 115V GFI-US	114
FIGURE 10-6. 115V IEC PLATFORM SOCKET INSTALL / INSTALLATION PRISE PLATE-FORME 115V IEC	116
FIGURE 10-7. INSTALL,PLATFORM OBSTACLE DETECTION / INSTALLATION DETECTION OBSTACLE	118
FIGURE 10-8. AIRLINE 5/16" INSTALL / INSTALLATION AIR COMPRISE 5/16"	120
FIGURE 10-9. WORKING LIGHT INSTALL / INSTALLATION PHARE DE TRAVAIL	122

TABLE OF CONTENTS

FIGURE 10-10. UCB PROTECTION INSTALL / INSTALLATION PROTECTION BOITIER HAUT	124
SECTION 11 - RECOMMENDED PARTS LIST / LISTE DE PIECES RECOMMANDEES.....	127
FIGURE 11-1. RECOMMENDED PARTS LIST / LISTE DE PIECES RECOMMANDEES	128
SECTION 12 - SPECIAL OPTIONS / OPTIONS SPECIALES.....	131
FIGURE 12-1. SPECIAL OPTIONS / OPTIONS SPECIALES	132
PART NUMBER INDEX.....	135

SECTION 1 - HOODS INSTALL / INSTALLATION CAPOTS

SECTION 1 - HOODS INSTALL / INSTALLATION CAPOTS

FIGURE 1-1. HOODS INSTALL / INSTALLATION CAPOTS

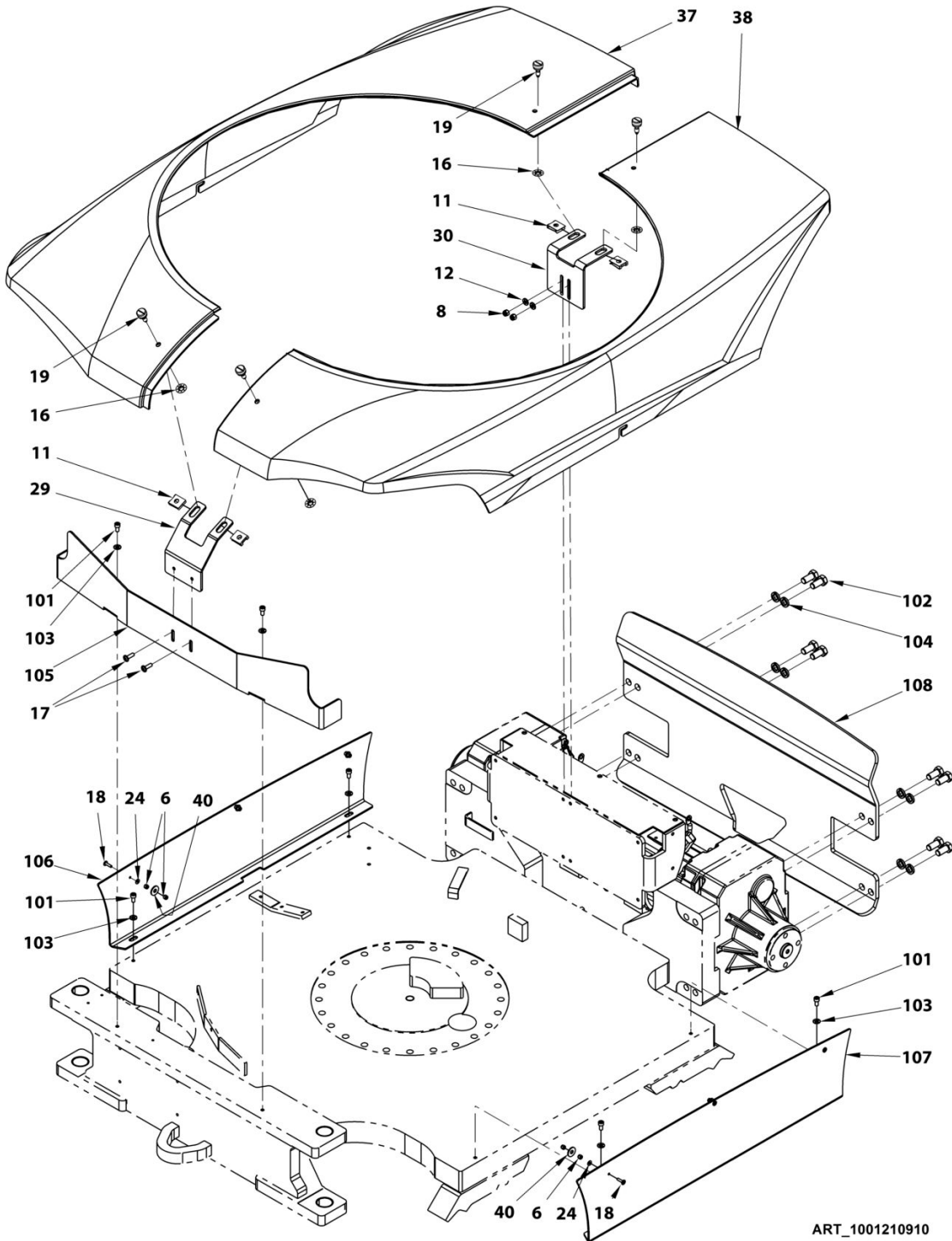

Oshkosh Corporation Classification - Restricted
SECTION 1 - HOODS INSTALL / INSTALLATION CAPOTS

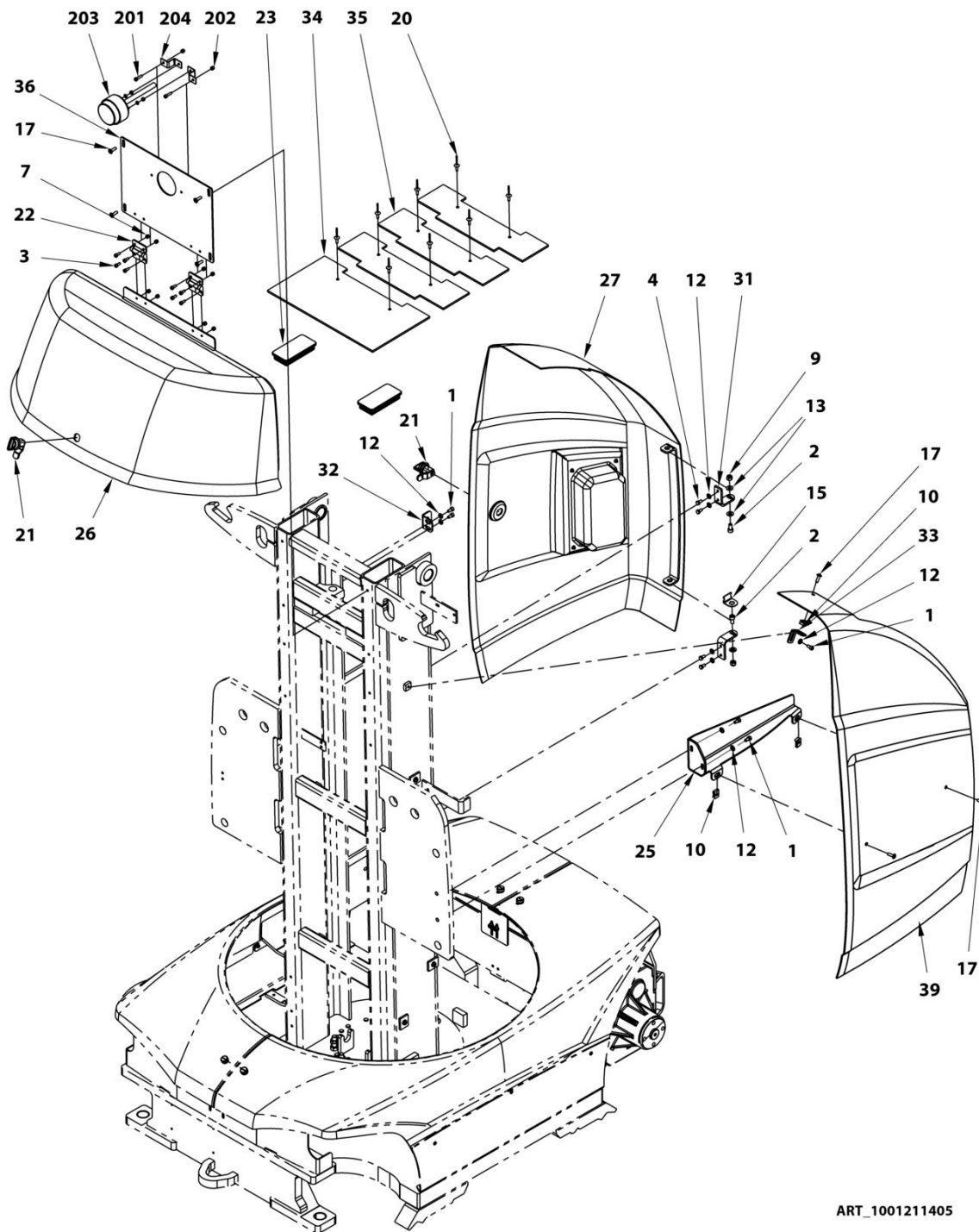

ART_1001211405

SECTION 1 - HOODS INSTALL / INSTALLATION CAPOTS

FIGURE 1-1. HOODS INSTALL / INSTALLATION CAPOTS

ITEM	PART NUMBER	QTY	DESCRIPTION	REV
	1001211405	Ref	HOODS INSTALL / INSTALLATION CAPOTS	D
1	000014	5	M06x12 8.8 SOCKET HEAD MACH SCREW / VIS CHC M06x12 8.8 BI FT	
2	000018	2	M08x16 8.8 SOCKET HEAD MACH SCREW / VIS CHC M08x16 8.8 BI FT	
3	000067	8	M05x12 8.8 SOCKET HEAD MACH SCREW / VIS CHC M05x12 8.8 BI FT	
4	100027	4	M06x12 8.8 HEX HEAD MACHINE SCREW / VIS H M06x12 8.8 BI FT	
6	110001	12	M04 GR. 8.8 LOCK NUT / ECROU FREIN M4 CL08 BI	
7	110002	8	M05 GR. 8.8 LOCK NUT / ECROU FREIN M5 CL08 BI	
8	110003	2	M06 GR. 8.8 LOCK NUT / ECROU FREIN M6 CL08 BI	
9	110004	2	M08 GR. 8.8 LOCK NUT / ECROU FREIN M8 CL08 BI	
10	110026	3	M06 CAGE HEX NUT / ECROU CAGE M06	
11	110040	4	D8 CAGE HEX NUT / ECROU CAGE D8	
12	120009	11	LOCK WASHER D06x14 / RONDELLE CONTACT dD 06x14 BI	
13	120010	3	LOCK WASHER D08x18 / RONDELLE CONTACT dD 08x18 BI	
15	ST3790	1	PLATE,CLIP / SUPPORT CABLE	
16	120057	4	D8 RETAINING WASHER / RONDELLE DE RETENUE D8	
17	130021	9	M06x20 8.8 ROUND HEAD MACH SCREW / VIS BOMBEE ULF M06x20 8.8 BI FT	
18	130062	6	M04x16 8.8 ROUND HEAD MACH SCREW / VIS BOMBEE ULF M04x16 8.8 BI FT	
19	130064	4	D8 FAST-LEAD THREAD SCREW / VIS D8 PAS RAPIDE TETE LARGE	
20	180009	8	Ø5x16 LARGE HEAD POP RIVET / RIVET POP TETE LARGE D5x16	
21	190072	2	COMPRESSION LATCH / LOQUET A COMPRESSION	
22	190074	2	FRICTION HINGE / CHARNIERE A FRICTION	
23	400057	2	CAP / EMBOUT NOIR	
24	120056	6	dD 04x08 LOCK WASHER / RONDELLE CONTACT dD 04x08 BI	
25	DL0937	1	SUPPORT,LEFT HOOD / SUPPORT CAPOT GAUCHE	
26	ST3114	1	HOOD, BATTERY / CAPOT BATTERIE	
27	ST3115	1	HOOD, MAST RIGHT / CAPOT MAT DROIT	
29	ST3170	1	SUPPORT,FRONT HOODS / SUPPORT AVANT CAPOT	
30	ST3171	1	SUPPORT,REAR HOODS / SUPPORT ARRIERE CAPOT	
31	ST3172	2	BRACKET,HOOD SUPPORT / EQUERRE SUPPORT CAPOT DROIT	
32	ST3173	1	PLATE,LATCH BRACKET / EQUERRE VERROU	
33	ST3174	1	BRACKET,HOOD SUPPORT / EQUERRE SUPPORT CAPOT GAUCHE	
34	ST3175	1	CAP,MAST TOP / COUVRE MAT	
35	ST3176	3	CAP,MAST TOP / COUVRE MAT	
36	ST3177	1	PLATE,MAST 1 TOP PANEL / OBTURATEUR MAT 1	
37	1001248814	1	HOOD,FRAME RIGHT / CAPOT CHASSIS DROIT	
38	1001248815	1	HOODS, FRAME LEFT / CAPOT CHASSIS GAUCHE	
39	ST3856	1	HOOD,MAST LEFT / CAPOT MAT GAUCHE	
40	120004	6	dD 06x25x1.2 WASHER / RONDELLE dD 06x25x1.2 BI	
	1001210910	Ref	FRAME SHIELDS INSTALL / INSTALLATION TOLES DE CHASSIS	A
101	000014	6	M06x12 8.8 SOCKET HEAD MACH SCREW / VIS CHC M06x12 8.8	

SECTION 1 - HOODS INSTALL / INSTALLATION CAPOTS

ITEM	PART NUMBER	QTY	DESCRIPTION	REV
102	100021	8	BI FT M12x25 8.8 HEX HEAD MACHINE SCREW / VIS H M12x25 8.8 BI FT	
103	120009	6	LOCK WASHER D06x14 / RONDELLE CONTACT dD 06x14 BI	
104	120054	8	HELICAL SPRING LOCK WASHER Ø12 / RONDELLE GROWER D12 BI	
105	ST3235	1	SHIELD,FRONT FRAME / CARTER AVANT CHASSIS	
106	ST3696	1	PLATE,FRAME RIGHT SHIELD / CARTER DROIT CHASSIS	
107	ST3697	1	PLATE,FRAME LEFT SHIELD / CARTER GAUCHE CHASSIS	
108	ST3841	1	PLATE,REAR FRAME SHIELD / TOLE ARRIERE CHASSIS	
	SA0021	Ref	BEACON INSTALL / INSTALLATION FEU A ECLATS	B
201	000010	2	M05x20 8.8 SOCKET HEAD MACH SCREW / VIS CHC M05x20 8.8 BI FT	
202	110002	2	M05 GR. 8.8 LOCK NUT / ECROU FREIN M5 CL08 BI	
203	PC0534	1	HARNESS,BEACON / FAISCEAU FEU A ECLATS	
204	ST3598	2	BRACKET,BEACON SUPPORT / CRAPAUD	

SECTION 2 - FRAME INSTALL / INSTALLATION CHASSIS

SECTION 2 - FRAME INSTALL / INSTALLATION CHASSIS

FIGURE 2-1. FRAME INSTALL / INSTALLATION CHASSIS

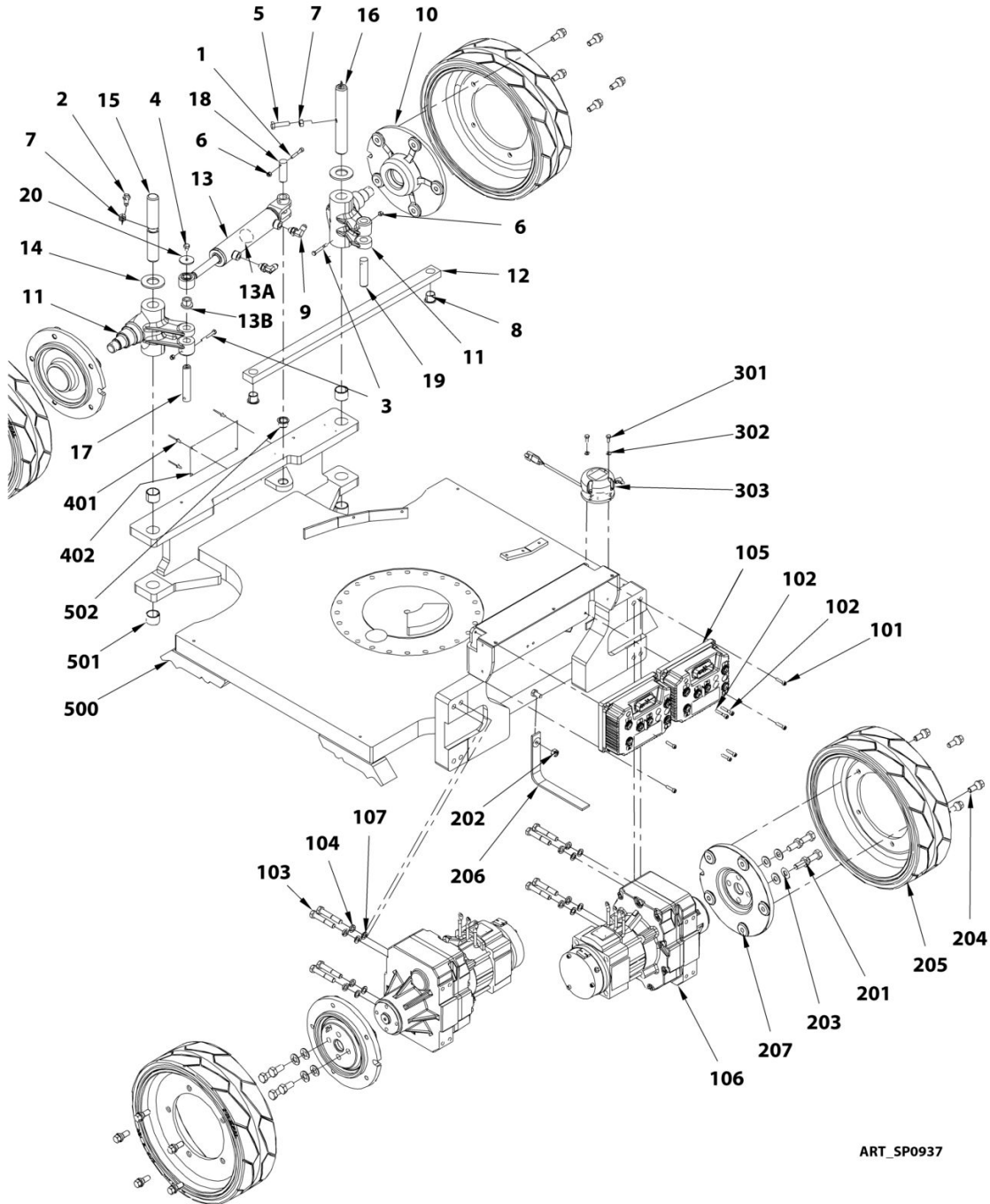

ART_SP0937

SECTION 2 - FRAME INSTALL / INSTALLATION CHASSIS**FIGURE 2-1. FRAME INSTALL / INSTALLATION CHASSIS**

ITEM	PART NUMBER	QTY	DESCRIPTION	REV
	SA0002	Ref	STEER INSTALL / INSTALLATION DIRECTION	D
1	000017	1	M06x40 8.8 SOCKET HEAD MACH SCREW / VIS CHC M06x40 8.8 BI FT	
2	100009	1	M10x30 8.8 HEX HEAD MACHINE SCREW / VIS H M10x30 8.8 BI FT	
3	100013	2	M06x50 8.8 HEX HEAD CAPSCREW / VIS H M06x50 8.8 BI FP	
4	100053	1	M08x12 8.8 HEX HEAD MACHINE SCREW / VIS H M08x12 8.8 BI FT	
5	100102	1	M10x40 8.8 HEX HEAD MACHINE SCREW / VIS H M10x40 8.8 BI FT	
6	110003	3	M06 GR08 LOCK NUT / ECROU FREIN M6 CL08 BI	
7	110008	2	M10 GR08 HEX NUT / ECROU H M10 CL08 BI	
8	150059	2	FLANGE BUSHING Ø20 H21.5 DU / BAGUE EPAULEE Ø20 H21.5 DU	
9	300001	2	90° ELBOW MALE BSPP 1/4-MALE JIC 9/16 / COUDE 90° Mâle BSPP 1/4 -Mâle JIC 9/16	
10	2780266	2	STEERING WHEEL HUB / MOYEU ROUE DIRECTRICE	
11	DL0819	2	SPINDLE / PIVOT DE DIRECTION	
12	ST3158	1	LINK, STEERING / BIELLETTE DE DIRECTION	
13	ST3332	1	STEERING CYLINDER SERTA / VERIN DE DIRECTION SERTA (Prior to SN A300060538)	
13A	960099	1	SEAL KIT CYLINDER ST3332 / KIT DE JOINTS VERIN ST3332 (Prior to SN A300060538)	
13B	150004	2	FLANGE BUSHING Ø20 H11.5 DU / BAGUE EPAULEE Ø20 H11.5 DU	
13	1001267689	1	STEERING CYLINDER BURNSIDE / VERIN DE DIRECTION BURNSIDE (SN A300060538 to Present)	
13A	1001272231	1	SEAL KIT CYLINDER 1001267689 / KIT DE JOINTS VERIN 1001267689 (SN A300060538 to Present)	
14	US0134	2	THRUST WASHER / RONDELLE D'APPUI	
15	US0216	1	SPINDLE PIN / AXE DE FUSEE	
16	US0523	1	PIN, ROTARY ANGLE SENSOR / AXE DIRECTION POUR CAPTEUR D'ANGLE	
17	US0528	1	PIN, ARTICULATION D20-104 / AXE D20-104	
18	US0529	1	PIN, ARTICULATION D20-60 / AXE D20-60	
19	US0530	1	PIN, ARTICULATION D20-80 / AXE D20-80	
20	US0531	1	WASHER, ID8xOD37xTH3 / RONDELLE Di 8xDe 37xEP 3	
	SA0001	Ref	WHEEL DRIVE INSTALL / INSTALLATION TRANSLATION	B
101	000008	6	M06x25 8.8 SOCKET HEAD MACH SCREW / VIS CHC M06x25 8.8 BI FT	
102	000077	2	M06x35 8.8 SOCKET HEAD CAPSCREW / VIS CHC M06x35 8.8 BI FP	
103	100103	8	M12x70 10.9 HEX HEAD CAPSCREW / VIS H M12x70 10.9 BR FP	
104	120054	8	HELICAL SPRING LOCK WASHER Ø12 / RONDELLE GROWER Ø12 BI	
105	1001241322	1	CONTROLLER, COMBI-ACO / VARIATEUR COMBI-ACO	
106	1001245202	1	DRIVE GEAR MOTOR / MOTOREDUCTEUR DE ROUE	
107	US0190	8	dDH 13x20x02 HARDENED WASHER / RONDELLE TRAITEE dDH 13x20x02	

SECTION 2 - FRAME INSTALL / INSTALLATION CHASSIS

ITEM	PART NUMBER	QTY	DESCRIPTION	REV
	SA0009	Ref	TIRES AND WHEEL INSTALL / INSTALLATION ROUES	C
201	100104	8	M14x1.5x30 10.9 HEX HEAD Mach SCREW / VIS H M14X1.5x30 10.9 BI FT	
202	110005	1	M10 GR08 LOCK NUT / ECROU FREIN M10 CL08 BI	
203	120055	8	dD 14x30 LOCK WASHER BI / RONDELLE CONTACT dD 14x30 BI	
204	0630580	20	BOLT, WHEEL M12x1.5 / GOUJON DE ROUE M12x1.5	
205	1001114466	4	WHEEL/TIRE 125x406 NON-MARKING / ROUE NON MARQUANTE 125x406	
206	4240147	1	STRAP, ANTI-STATIC 13" / TRESSE ANTI-STATIQUE 13"	
207	US0532	2	HUB, DRIVE / MOYEU ARRIERE	
	1001211358	Ref	2.5° TILT SWITCH INSTALL / INSTALLATION DEVERS 2.5°	A
301	100098	2	M06x16 8.8 HEX HEAD MACHINE SCREW / VIS H M06x16 8.8 BI FT	
302	120009	2	dD 06x14 LOCK WASHER / RONDELLE CONTACT dD 06x14 BI	
303	1001213835	1	SENSOR,TILT 2.5° / DETECTEUR DE DEVERS 2.5°	
	SA0144	Ref	SERIAL NUMBER TAG INSTALL EU / INSTALLATION PLAQUE CONSTRUCTEUR CE	B
	1001213632	Ref	SERIAL NUMBER TAG INSTALL AS-NZS / INSTALLATION PLAQUE CONSTRUCTEUR AS/NZS	C
	1001223689	Ref	SERIAL NUMBER TAG INSTALL ANSI-CSA / INSTALLATION PLAQUE CONSTRUCTEUR ANSI-CSA	A
401	180003	4	Ø5x10 POP RIVET / RIVET POP Ø5x10	
402		Ref	MANUFACTURER'S NAME PLATE / PLAQUE CONSTRUCTEUR	
500	DL0921	1	FRAME WELDMENT / CHASSIS	
501	150019	4	BUSHING Ø30 H25 DU / BAGUE Ø30 H25 DU	
502	150058	1	FLANGE BUSHING Ø20 H16.5 / BAGUE EPAULEE Ø20 H16.5	

SECTION 2 - FRAME INSTALL / INSTALLATION CHASSIS

FIGURE 2-2. STEERING WHEEL HUB / MOYEU ROUE DIRECTRICE

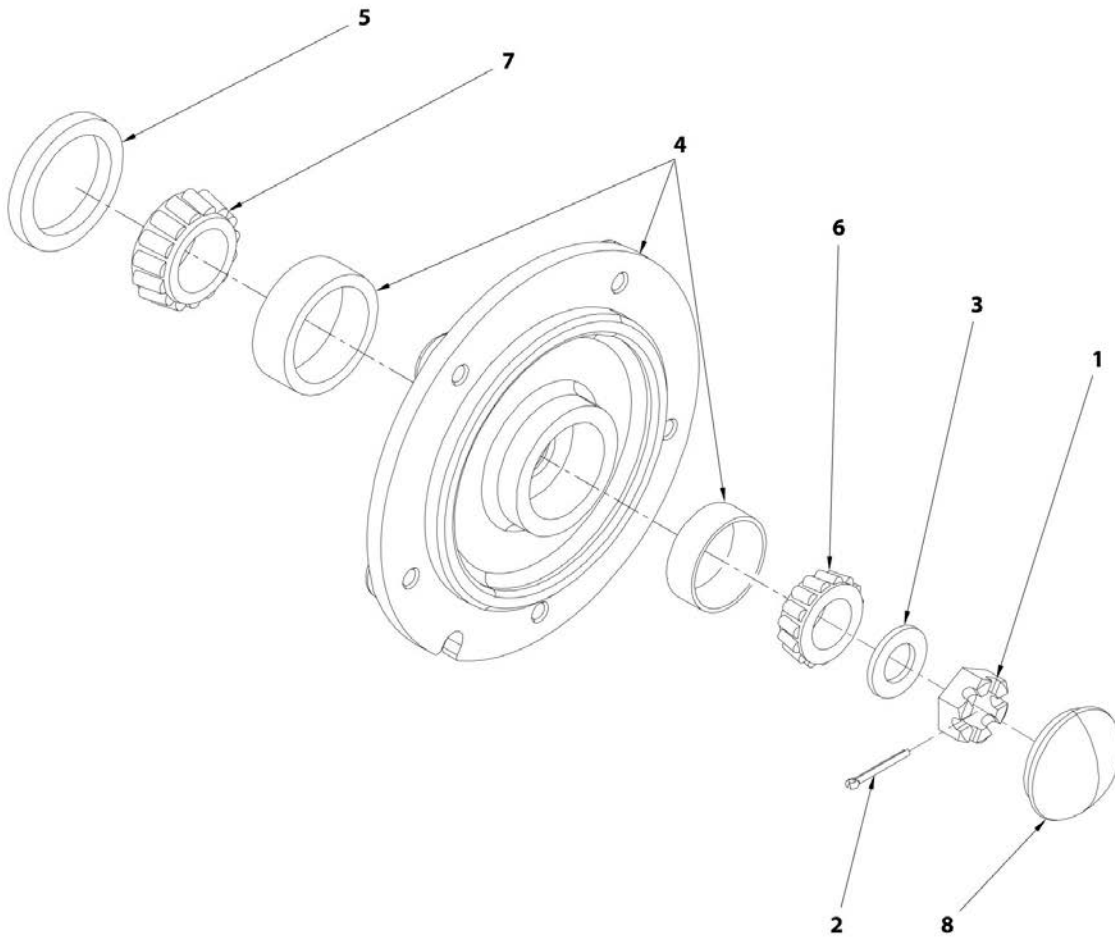

ART_2780266

SECTION 2 - FRAME INSTALL / INSTALLATION CHASSIS**FIGURE 2-2. STEERING WHEEL HUB / MOYEU ROUE DIRECTRICE**

ITEM	PART NUMBER	QTY	DESCRIPTION	REV
	2780266		HUB, STEERING WHEEL / MOYEU ROUE DIRECTRICE	E
1	3300423	1	NUT,SLOTTED / ECROU A ENCOCHE	
2	3450406	1	PIN, COTTER 2" x 3/16" / GOUPILLE FENDUE 2" x 3/16"	
3	4740468	1	WASHER / RONDELLE	
4	1001102189	1	HUB,REAR (ASSY) / KIT MOYEU	
5	1001102349	1	SEAL,GREASE / JOINT GRAISSE	
6	1001102351	1	BEARING CONE INNER / ROULEMENT CONIQUE INTERIEUR	
7	1001102353	1	BEARING CONE OUTER / ROULEMENT CONIQUE EXTERIEUR	
8	1001102354	1	CAP,GREASE / BOUCHON GRAISSE	

SECTION 2 - FRAME INSTALL / INSTALLATION CHASSIS

FIGURE 2-3. DRIVE GEAR MOTOR / MOTOREDUCTEUR DE ROUE

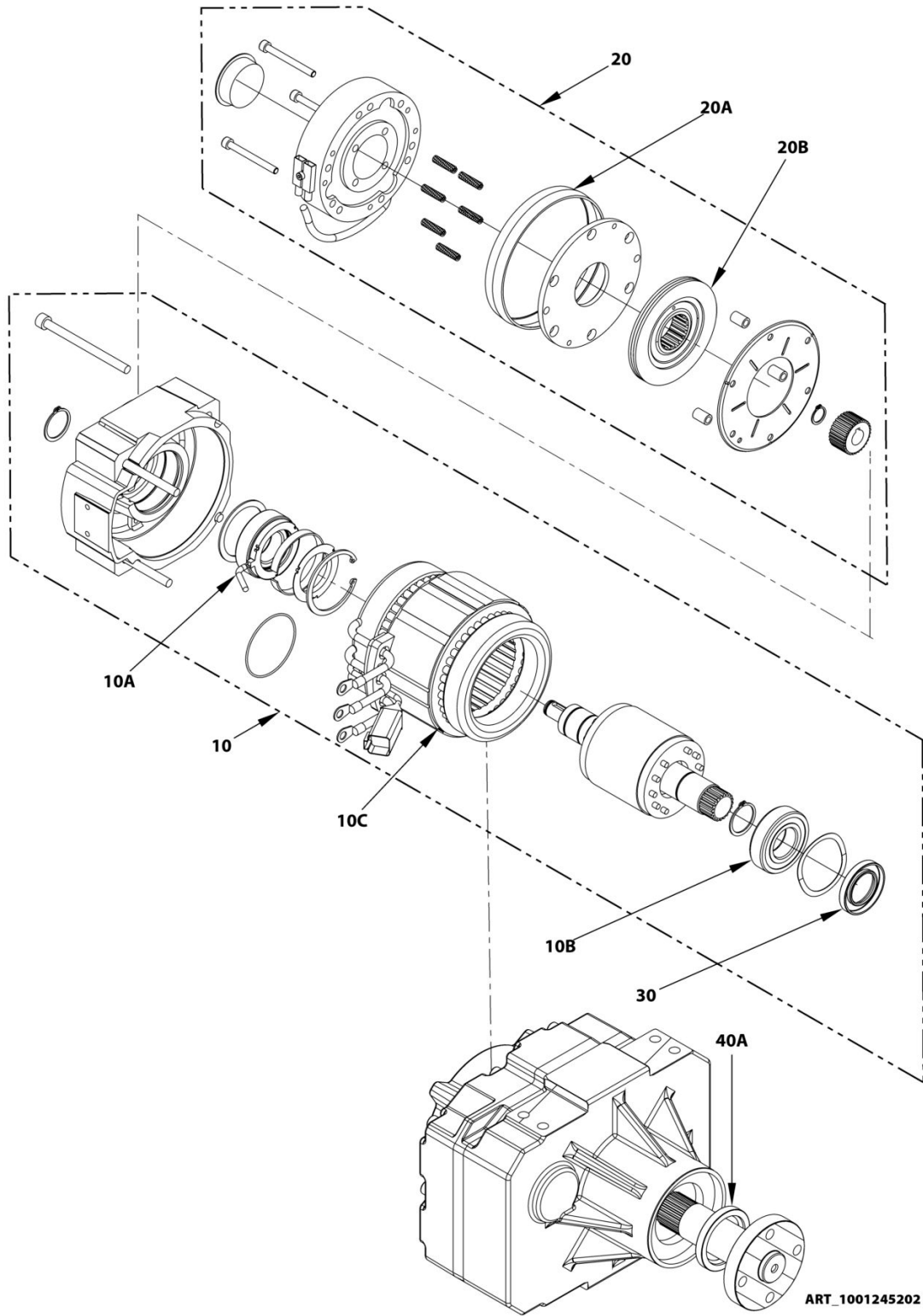

SECTION 2 - FRAME INSTALL / INSTALLATION CHASSIS**FIGURE 2-3. DRIVE GEAR MOTOR / MOTOREDUCTEUR DE ROUE**

ITEM	PART NUMBER	QTY	DESCRIPTION	REV
	1001245202	1	DRIVE GEAR MOTOR / MOTOREDUCTEUR DE ROUE	B
10	1001246577	1	ELECTRIC MOTOR / MOTEUR ELECTRIQUE	
10A	951039	1	ENCODER BEARING KIT / KIT ROULEMENT CODEUR	
10B	951041	1	BEARING 6206ZC3/HTF / ROULEMENT 6206ZC3/HTF	
10C	1001246578	1	PT1000-STATOR / PT1000-STATOR	
20	951036	1	COMPLETE BRAKE KIT / FREIN COMPLET	
20A	951037	1	RING, DUST PROTECTION / JOINT ANTI-POUSSIERE	
20B	951038	1	DISC, FRICTION / DISQUE DE FREIN	
30	951040	1	GASKET WDR 30x52x7 / JOINT A LEVRE WDR 30x52x7	
40A	1001233406	1	SEAL,RADIAL 45X62X8 / JOINT A LEVRE 45X62X8	

SECTION 3 - MAST 1 INSTALL / INSTALLATION MAT 1

SECTION 3 - MAST 1 INSTALL / INSTALLATION MAT 1

SECTION 3 - MAST 1 INSTALL / INSTALLATION MAT 1

FIGURE 3-1. MAST 1 INSTALL / INSTALLATION MAT 1

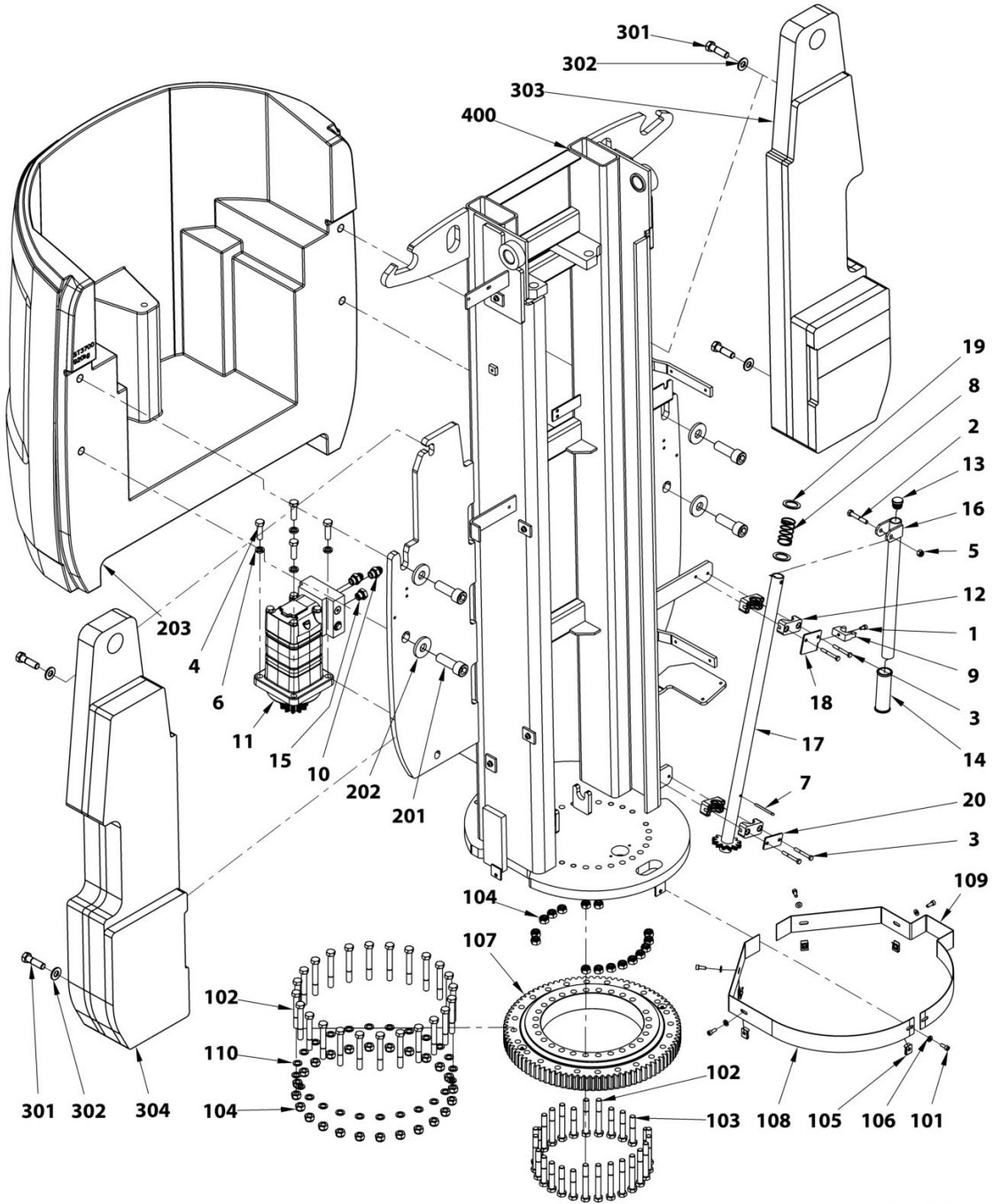

ART_SP0938_C

SECTION 3 - MAST 1 INSTALL / INSTALLATION MAT 1**FIGURE 3-1. MAST 1 INSTALL / INSTALLATION MAT 1**

ITEM	PART NUMBER	QTY	DESCRIPTION	REV
	SA0004	Ref	SWING DRIVE INSTALL / INSTALLATION ORIENTATION	C
1	000014	1	M06x12 8.8 SOCKET HEAD MACH SCREW / VIS CHC M06x12 8.8 BI FT	
2	100007	1	M08x50 8.8 HEX HEAD CAPSCREW / VIS H M08x50 8.8 BI FP	
3	100013	4	M06x50 8.8 HEX HEAD CAPSCREW / VIS H M06x50 8.8 BI FP	
4	100016	4	M12x40 8.8 HEX HEAD MACHINE SCREW / VIS H M12x40 8.8 BI FT	
5	110004	1	M08 GR08 LOCK NUT / ECROU FREIN M8 CL08 BI	
6	120054	4	HELICAL SPRING LOCK WASHER Ø12 / RONDELLE GROWER Ø12 BI	
7	140009	1	Ø4.5x50 COTTER PIN / GOUPILLE FENDUE Ø4.5x50	
8	160031	1	C 320 180 1350 I SPRING / RESSORT C 320 180 1350 I	
9	190027	1	Ø22 CLIP / CLIP Ø22	
10	300172	2	ADAPTATOR 3/8 BSPP - O-RING / RACCORD 3/8 BSPP - JOINT TORIQUE	
11	320067	1	HYD. MOTOR, SWING DRIVE / MOTEUR D'ORIENTATION	
12	400077	2	CLAMP, SINGLE D30 / COLLIER D30	
13	400097	1	CAP, D25 / BOUCHON D25	
14	930109	1	PUMP HANDLE RUBBER / CAOUTCHOUC POIGNEE POMPE	
15	100111752	1	CAP 3/8 BSPP - O-RING / BOUCHON 3/8 BSPP - JOINT TORIQUE	
16	DL0837	1	LEVER, MANUAL SLEWING / LEVIER D'ORIENTATION MANUELLE	
17	DL0838	1	PINION / PIGNON ARBRE	
18	ST3246	1	PLATE, LEVER LOCK / PLATINE BLOCAGE LEVIER	
19	US0524	2	WASHER, ID28xOD40xTH2 / RONDELLE Di 28xDe 40xEP 2	
20	US0527	1	PLATE, CLAMP COVER / BRIDE DE COLLIER	
	SA0003	Ref	TURNTABLE BEARING INSTALL / INSTALLATION COURONNE D'ORIENTATION	A
101	000015	5	M06x16 8.8 SOCKET HEAD MACH SCREW / VIS CHC M06x16 8.8 BI FT	
102	100038	40	M12x90 10.9 HEX HEAD CAPSCREW / VIS H M12x90 10.9 BR FP	
103	100103	11	M12x70 10.9 HEX HEAD CAPSCREW / VIS H M12x70 10.9 BR FP	
104	110017	40	M12 GR10 LOCK NUT / ECROU FREIN H M12 CL10 BI	
105	110026	5	M06 CAGE HEX NUT / ECROU CAGE M06	
106	120009	5	dD 06x14 LOCK WASHER / RONDELLE CONTACT dD 06x14 BI	
107	500021	1	SLEWING RING / COURONNE D'ORIENTATION	
108	ST3164	1	COVER, SLEWING RING, LEFT / CARTER COURONNE GAUCHE	
109	ST3169	1	COVER, SLEWING RING, RIGHT / CARTER COURONNE DROIT	
110	US0190	24	dDH 13x20x02 HARDENED WASHER / RONDELLE TRAITEE dDH 13x20x02	
	1001211410	Ref	10E-COUNTERWEIGHT 920KG INSTALL / 10E-INSTALLATION CONTREPOIDS 920KG	C
	1001223609	Ref	26E-COUNTERWEIGHT 1060KG INSTALL / 26E-INSTALLATION CONTREPOIDS 1060KG	B
201	1001227894	4	M20x60 8.8 HEX HEAD MACH. SCREW / VIS H 20x60 8.8 BI FT	
202	ST2475	4	COUNTERWEIGHT WASHER / RONDELLE DE CONTREPOIDS	
203	ST3700	1	10E-COUNTERWEIGHT / 10E-CONTREPOIDS	
203	1001223892	1	26E-COUNTERWEIGHT / 26E-CONTREPOIDS	

SECTION 3 - MAST 1 INSTALL / INSTALLATION MAT 1

ITEM	PART NUMBER	QTY	DESCRIPTION	REV
	1001211417	Ref	ADDITIONAL COUNTERWEIGHTS INSTALL / INSTALLATION CONTREPOIDS ADDITIONNELS	B
301	100033	4	M14x50 8.8 HEX HEAD CAPSCREW / VIS H M14x50 8.8 BR FP	
302	120055	4	dD 14x30 LOCK WASHER BI / RONDELLE CONTACT dD 14x30 BI	
303	1001213144	1	WEIGHT,ADDITIONAL CW,RIGHT / CONTREPOIDS ADDITIONNEL DROIT	
304	1001213145	1	WEIGHT,ADDITIONAL CW,LEFT / CONTREPOIDS ADDITIONNEL GAUCHE	
400	DL0934	1	MAST,TURNTABLE / MAT 1	

SECTION 3 - MAST 1 INSTALL / INSTALLATION MAT 1

FIGURE 3-2. MTB INSTALL / INSTALLATION COMMANDES BASSES

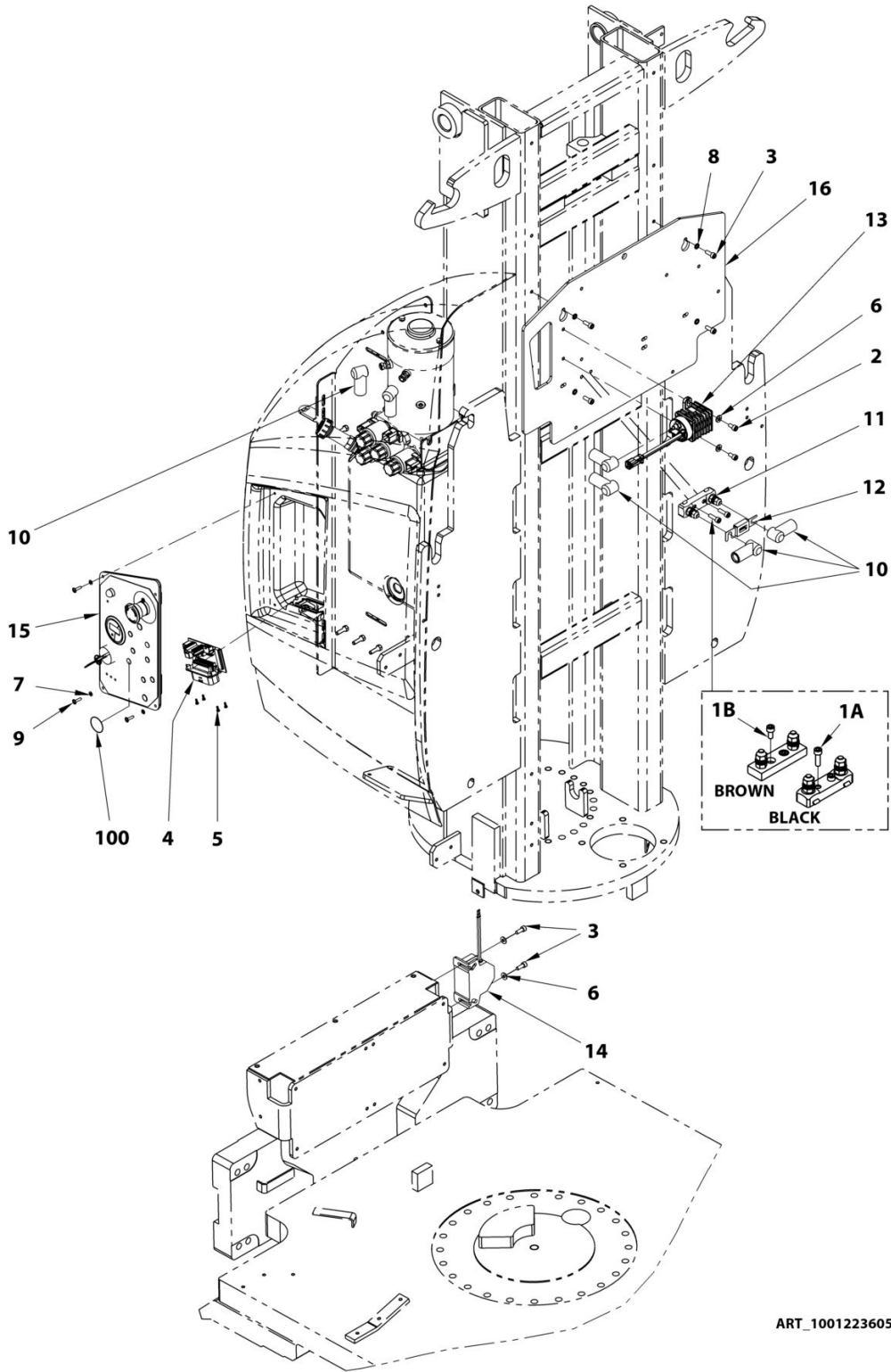

ART_1001223605

SECTION 3 - MAST 1 INSTALL / INSTALLATION MAT 1**FIGURE 3-2. MTB INSTALL / INSTALLATION COMMANDES BASSES**

ITEM	PART NUMBER	QTY	DESCRIPTION	REV
	1001211406	Ref	MTB (W/O ENABLE & WITH MSSO) / COMMANDES BASSES (SANS VALIDATION AVEC MSSO)	B
	1001223605	Ref	MTB (W/O ENABLE & W/O MSSO) / COMMANDES BASSES (SANS VALIDATION SANS MSSO)	B
	1001267296	Ref	MTB (WITH ENABLE & WITH MSSO) / COMMANDES BASSES (AVEC VALIDATION AVEC MSSO)	A
	1001267297	Ref	MTB (WITH ENABLE & W/O MSSO) / COMMANDES BASSES (AVEC VALIDATION SANS MSSO)	A
1A	000005	2	M06x20 8.8 SOCKET HEAD MACH SCREW / VIS CHC M06x20 8.8 BI FT	
1B	000014	2	M06x12 8.8 SOCKET HEAD MACH SCREW / VIS CHC M06x12 8.8 BI FT	
2	000014	2	M06x12 8.8 SOCKET HEAD MACH SCREW / VIS CHC M06x12 8.8 BI FT	
3	000015	6	M06x16 8.8 SOCKET HEAD MACH SCREW / VIS CHC M06x16 8.8 BI FT	
4	1001187631	1	PC BRD,INTERFACE,10E / CARTE ELECTRONIQUE INTERFACE	
5	1001210948	4	SCREW-SPEC,TORX D3 L8 METRIC / VIS TORX D3xL8 POUR THERMOPLASTIQUE	
6	120009	4	LOCK WASHER D06x14 / RONDELLE CONTACT dD 06x14 BI	
7	120033	4	M04 PLASTIC WASHER / RONDELLE PLASTIQUE M4	
8	120060	4	WASHER D6 SERRATED LOCK / RONDELLE EVENTAIL D6	
9	130062	4	M04x16 8.8 ROUND HEAD MACH SCREW / VIS BOMBEE ULF M04x16 8.8 BI FT	
10	250031	6	BOOT,BATTERY TERMINAL / CAPUCHON D'ETANCHEITE	
11	260077	1	POWER FUSE HOLDER / PORTE FUSIBLE DE PUISSANCE	
12	260079	1	325A FUSE / FUSIBLE 325A	
13	3740150	1	RELAY,24VDC/100A / RELAIS, 24VDC/100A	
14	PC0491	1	HARNESS, HORN / FAISCEAU AVERTISSEUR SONORE	
15	SE1200	1	GROUND CONTROL PANEL WITH ENABLE / BOITIER BAS AVEC VALIDATION	
15	1001223810	1	GROUND CONTROL PANEL WITHOUT ENABLE / BOITIER BAS SANS VALIDATION	
16	ST3774	1	MOUNT,ELEC COMPONENTS / PLATINE COMPOSANTS ELECTRIQUES	
100	AU2228	1	DECAL,INDICATOR COVER D42 / AUTOCOLLANT MASQUE D42	

SECTION 3 - MAST 1 INSTALL / INSTALLATION MAT 1

FIGURE 3-3. GROUND CONTROL PANEL WITH ENABLE / BOITIER BAS AVEC VALIDATION

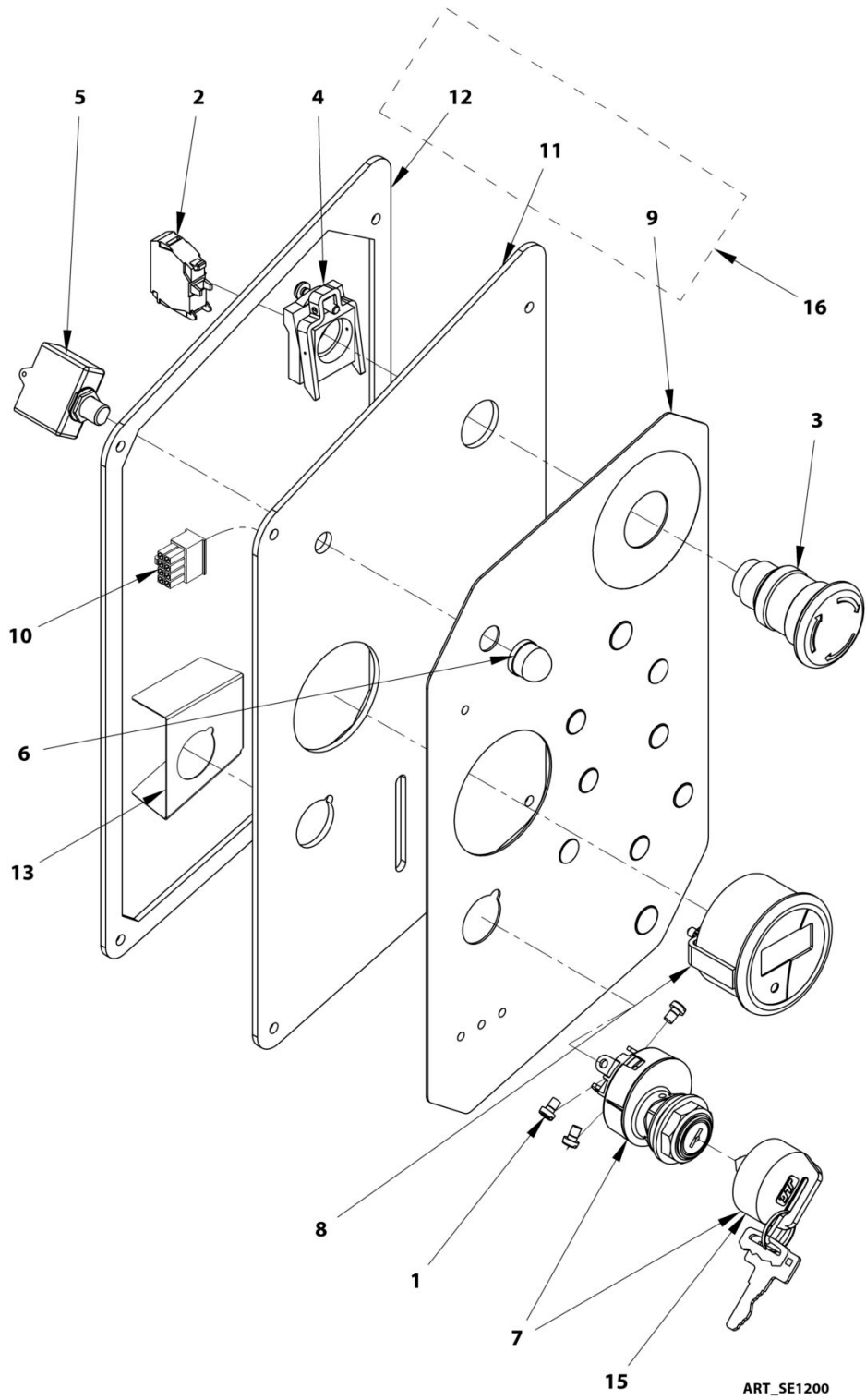

SECTION 3 - MAST 1 INSTALL / INSTALLATION MAT 1**FIGURE 3-3. GROUND CONTROL PANEL WITH ENABLE / BOITIER BAS AVEC VALIDATION**

ITEM	PART NUMBER	QTY	DESCRIPTION	REV
	SE1200		GROUND CONTROL PANEL WITH ENABLE / FACADE BOITIER BAS AVEC VALIDATION	B
1	130059	3	M04x06 GR. 4.8 CYLINDRIC HEAD / VIS TC M04x06 4.8 ZI	
2	240057	1	NC CONTACT BLOCK / CONTACT NF	
3	240060	1	TURN TO RELEASE KNOB / BOUTON D'ARRET D'URGENCE	
4	240076	1	CONTACT BLOCK HOLDER / EMBASE CONTACT	
5	260240	1	CIRCUIT BREAKER 5A / DISJONCTEUR 5A	
6	260243	1	CIRCUIT BREAKER BOOT / CAPUCHON DISJONCTEUR	
7	4360469	1	SWITCH,KEY ON/OFF/ON / SELECTEUR A CLE 3 POSITIONS	
8	1001109503	1	MULTI DISPLAY INDICATOR / AFFICHEUR MULTIFONCTIONS	
9	AU2207	1	MEMBRANE SWITCHES,GROUND PANEL / INTERRUPTEURS A MEMBRANE BOITIER BAS	
10	PC0465	1	HARNESS, LCB / FAISCEAU BOITIER BAS	
11	ST3775	1	GROUND PANEL / PLATINE BOITIER BAS	
12	ST3155	1	GASKET,GROUND PANEL / JOINT BOITER BAS	
13	1001239552	1	PLATE,KEY SWITCH CAP / CAPOT SELECTEUR A CLE	
15	2860030	1	KEY (INCLUDED IN ITEM 4360469) / CLE (COMPRISE DANS REF 4360469)	
16	SE1202	1	KIT(SERVICE),DECAL PLATE AND SEAL / KIT AUTOCOLLANT, PLATINE ET JOINT BOITIER BAS	

SECTION 3 - MAST 1 INSTALL / INSTALLATION MAT 1

FIGURE 3-4. GROUND CONTROL PANEL W/O ENABLE / BOITIER BAS SANS VALIDATION

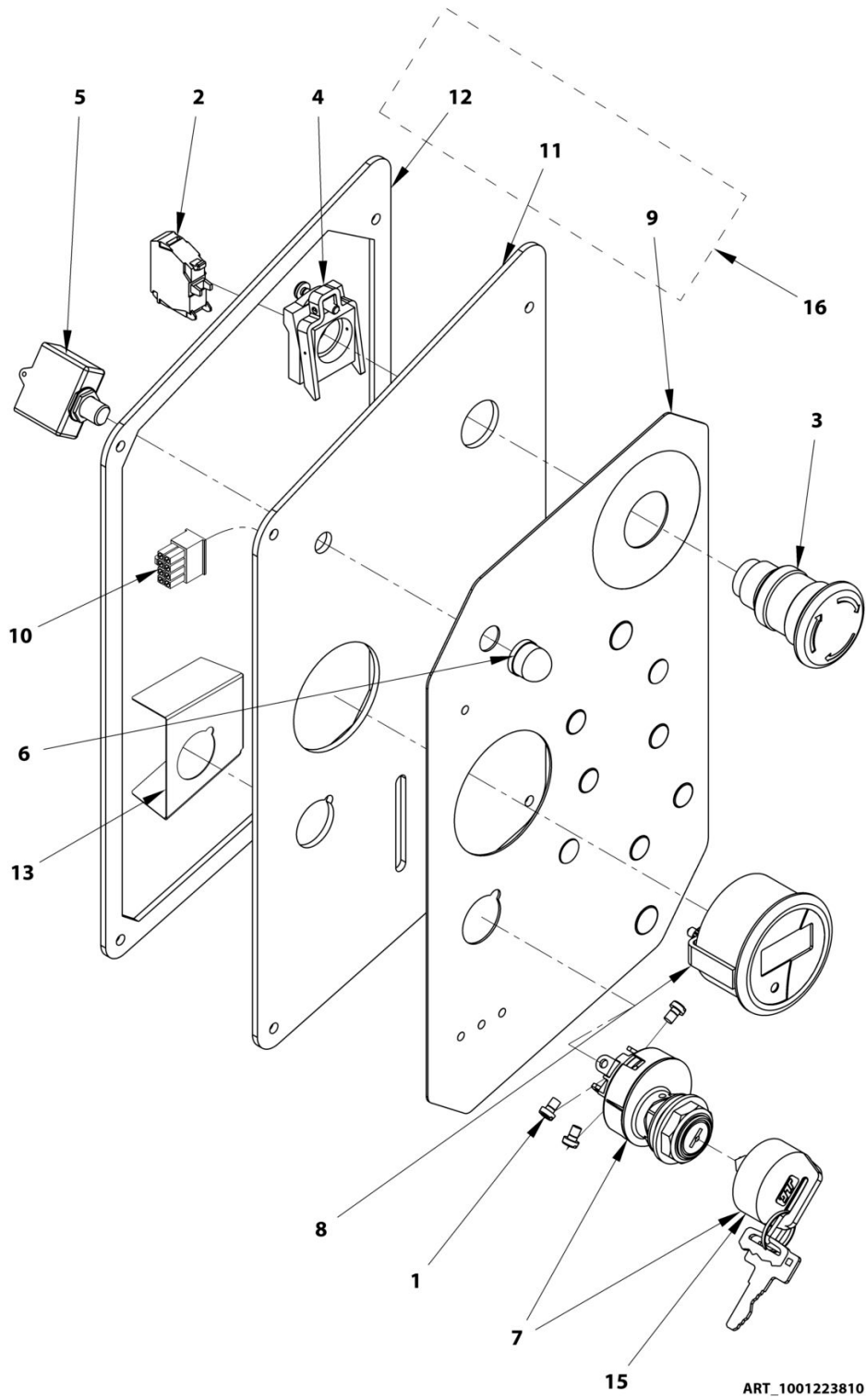

SECTION 3 - MAST 1 INSTALL / INSTALLATION MAT 1

FIGURE 3-4. GROUND CONTROL PANEL W/O ENABLE / BOITIER BAS SANS VALIDATION

ITEM	PART NUMBER	QTY	DESCRIPTION	REV
	1001223810		GROUND CONTROL PANEL WITHOUT ENABLE / BOITIER BAS SANS VALIDATION	B
1	130059	3	M04x06 GR. 4.8 CYLINDRIC HEAD / VIS TC M04x06 4.8 ZI	
2	240057	1	NC CONTACT BLOCK / CONTACT NF	
3	240060	1	TURN TO RELEASE KNOB / BOUTON D'ARRET D'URGENCE	
4	240076	1	CONTACT BLOCK HOLDER / EMBASE CONTACT	
5	260240	1	CIRCUIT BREAKER 5A / DISJONCTEUR 5A	
6	260243	1	CIRCUIT BREAKER BOOT / CAPUCHON DISJONCTEUR	
7	4360469	1	SWITCH,KEY ON/OFF/ON / SELECTEUR A CLE 3 POSITIONS	
8	1001109503	1	MULTI DISPLAY INDICATOR / AFFICHEUR MULTIFONCTIONS	
9	1001223811	1	MEMBRANE SWITCHES,GROUND PANEL / INTERRUPTEURS A MEMBRANE BOITIER BAS	
10	PC0465	1	HARNESS, LCB / FAISCEAU BOITIER BAS	
11	ST3775	1	GROUND PANEL / PLATINE BOITIER BAS	
12	ST3155	1	GASKET,GROUND PANEL / JOINT BOITER BAS	
13	1001239552	1	PLATE,KEY SWITCH CAP / CAPOT SELECTEUR A CLE	
15	2860030	1	KEY (INCLUDED IN ITEM 4360469) / CLE (COMPRISE DANS REF 4360469)	
16	1001223812	1	KIT(SERVICE),DECAL PLATE AND SEAL / KIT AUTOCOLLANT, PLATINE ET JOINT BOITIER BAS	

SECTION 4 - MAST AND BOOM INSTALL / INSTALLATION MATS ET BRAS

**SECTION 4 - MAST AND BOOM INSTALL / INSTALLATION MATS ET
BRAS**

SECTION 4 - MAST AND BOOM INSTALL / INSTALLATION MATS ET BRAS

FIGURE 4-1. MAST AND BOOM INSTALL / INSTALLATION MAT ET BRAS

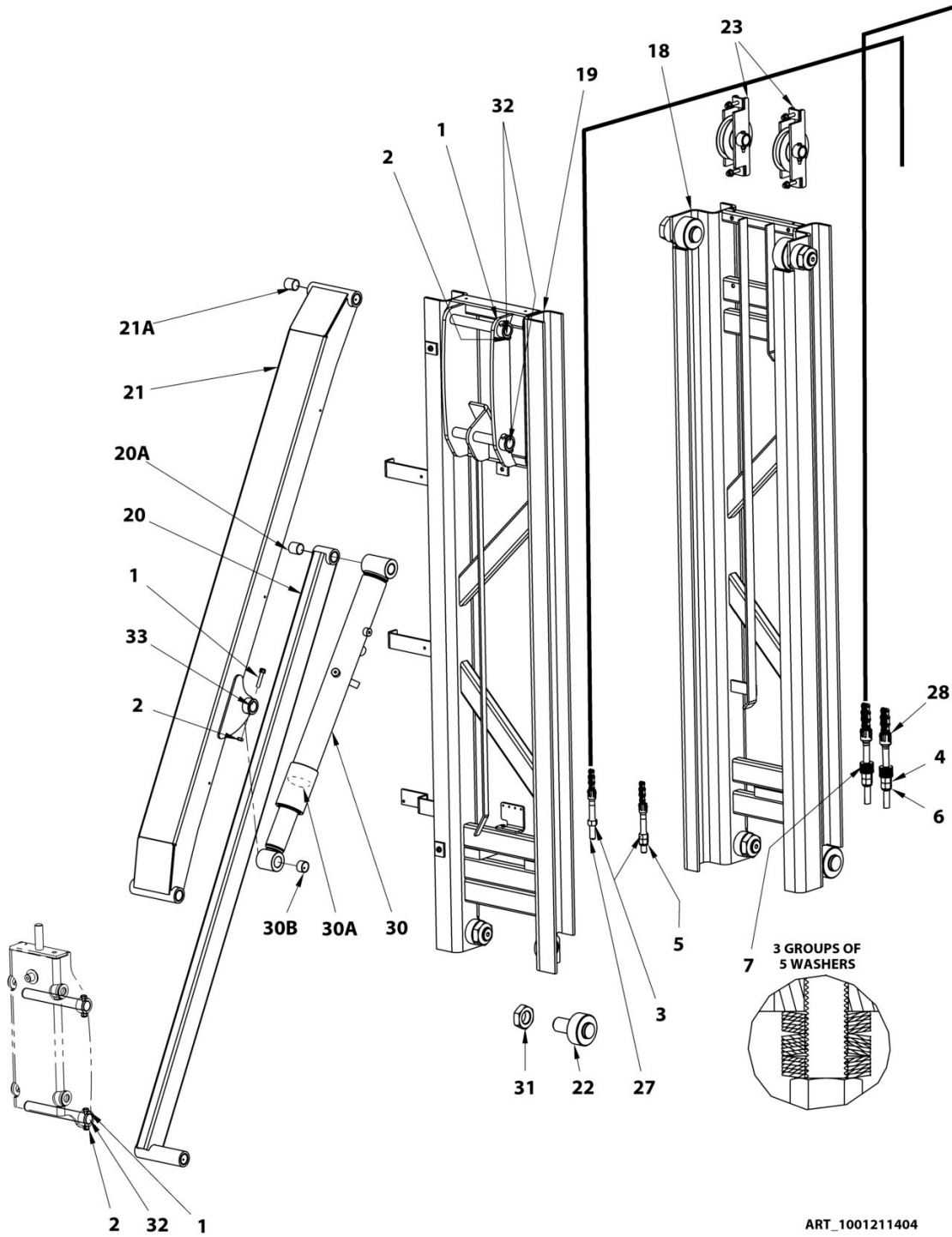

ART_1001211404

SECTION 4 - MAST AND BOOM INSTALL / INSTALLATION MATS ET BRAS

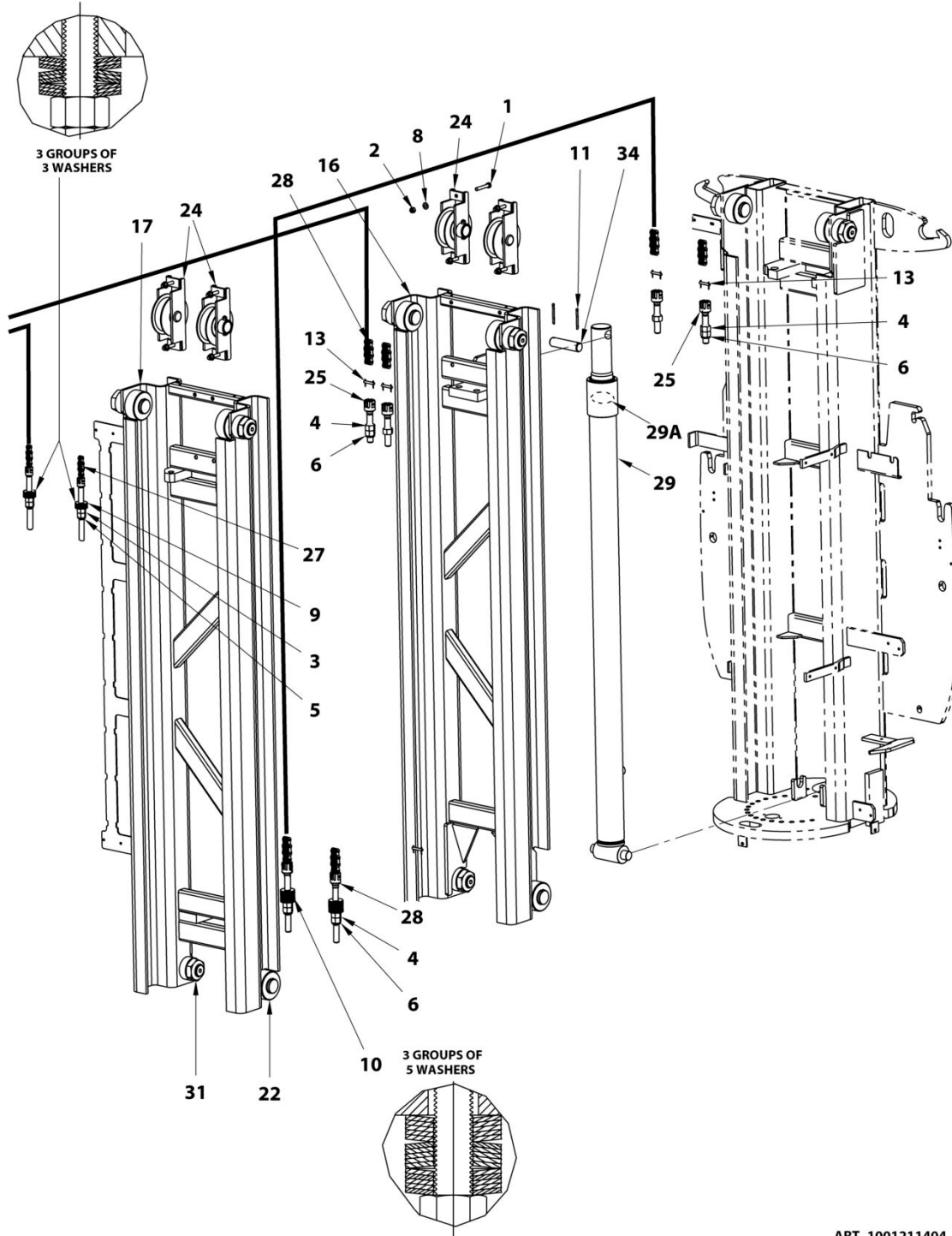

ART_1001211404

SECTION 4 - MAST AND BOOM INSTALL / INSTALLATION MATS ET BRAS

FIGURE 4-1. MAST AND BOOM INSTALL / INSTALLATION MAT ET BRAS

ITEM	PART NUMBER	QTY	DESCRIPTION	REV
	1001211404	Ref	MAST AND BOOM INSTALL / INSTALLATION MAT ET BRAS	F
1	100063	17	M08x50 8.8 HEX HEAD MACHINE SCREW / VIS H M08x50 8.8 BI FT	
2	110004	17	M08 GR08 LOCK NUT / ECROU FREIN M8 CL08 BI	
3	110009	4	M14 GR08 HEX NUT / ECROU H M14 CL08 BI	
4	110010	8	M16 GR08 HEX NUT / ECROU H M16 CL08 BI	
5	110019	3	M14 GR08 LOCK NUT / ECROU FREIN H M14 CL08 BI	
6	110020	6	M16 GR08 LOCK NUT / ECROU FREIN H M16 CL08 BI	
7	120006	30	BEVEL WASHER D34x16.3x1.5 / RONDELLE RESSORT D34x16.3x1.5 BR	
8	120010	12	dD 08x18 LOCK WASHER / RONDELLE CONTACT dD 08x18 BI	
9	120017	18	BEVEL WASHER D34x14.3x1.5 / RONDELLE RESSORT D34x14.3x1.5 BR	
10	120036	30	BEVEL WASHER Ø40x16.3x2 / RONDELLE RESSORT Ø40x16.3x2 BR	
11	140009	2	D4.5x50 COTTER PIN / GOUPILLE FENDUE D4.5x50	
13	170008	4	M16 CLEVIS PIN / AXE DE CHAPE M16	
16	DL0818	1	MAST 2 / MAT 2	
17	DL0935	1	MAST 3 / MAT 3	
18	DL0824	1	MAST 4 / MAT 4	
19	DL0936	1	MAST 5 / MAT 5	
20	DL0924	1	BOOM,LOWER / BRAS INFERIEUR	
20A	150002	4	BUSHING Ø25 H25 DX / BAGUE D25 H25 DX	
21	DL0923	1	BOOM,UPPER / BRAS SUPERIEUR	
21A	150002	4	BUSHING Ø25 H25 DX / BAGUE D25 H25 DX	
22	SE1214	16	ROLLER,ASSEMBLY M36 / ENSEMBLE GALET DE GUIDAGE M36	
23	SE0730	2	PULLEY ASSEMBLY LL10-44 / ASSEMBLAGE SUPPORT POULIE LL10-44	
24	SE0731	4	PULLEY ASSEMBLY LL12-66 / ASSEMBLAGE SUPPORT POULIE LL12-66	
25	ST0099	4	CHAIN ANCHOR M16 L80 / CHAPE DE CHAINE M16 L80	
27	1001220619	2	CHAIN,LL10-44 EQUIPPED / CHAINE LL10-44 EQUIPEE	
28	1001220620	4	CHAIN,LL12-66 1 SIDE EQUIPPED / CHAINE LL10-66 EQUIPEE 1 COTE	
29	ST3333	1	MAST CYLINDER SERTA / VERIN MAT SERTA (Prior to SN A300060538)	
29A	960098	1	SEAL KIT CYLINDER ST3333 / KIT DE JOINTS VERIN ST3333 (Prior to SN A300060538)	
29	1001267690	1	MAST CYLINDER BURNSIDE / VERIN MAT BURNSIDE (SN A300060538 to Present)	
29A	1001272232	1	SEAL KIT CYLINDER 1001267690 / KIT DE JOINTS VERIN 1001267690 (SN A300060538 to Present)	
30	1001225702	1	BOOM CYLINDER SERTA / VERIN BRAS SERTA (Prior to SN A300060538)	
30A	960097	1	SEAL KIT CYLINDER 1001225702 / KIT DE JOINTS VERIN 1001225702 (Prior to SN A300060538)	
30B	150002	4	BUSHING D25 H25 DX / BAGUE D25 H25 DX	
30	1001267688	1	BOOM CYLINDER BURNSIDE / VERIN BRAS BURNSIDE (SN A300060538 to Present)	
30A	1001272230	1	SEAL KIT CYLINDER 1001267688 / KIT DE JOINTS VERIN 1001267688 (SN A300060538 to Present)	
31	US0026	16	M36 GR04 HEX NUT / ECROU M36 CL04 BI	

SECTION 4 - MAST AND BOOM INSTALL / INSTALLATION MATS ET BRAS

ITEM	PART NUMBER	QTY	DESCRIPTION	REV
32	US0481	4	PIN D25 L210 / AXE D25 L210	
33	US0537	1	PIN, D25 - L100 / AXE D25 - L100	
34	US0538	1	PIN, D25-L100-2d5 / AXE D25 - L100 - 2d5	

SECTION 4 - MAST AND BOOM INSTALL / INSTALLATION MATS ET BRAS

FIGURE 4-2. PULLEY SUPPORT LL10-44 / SUPPORT POULIE LL10-44

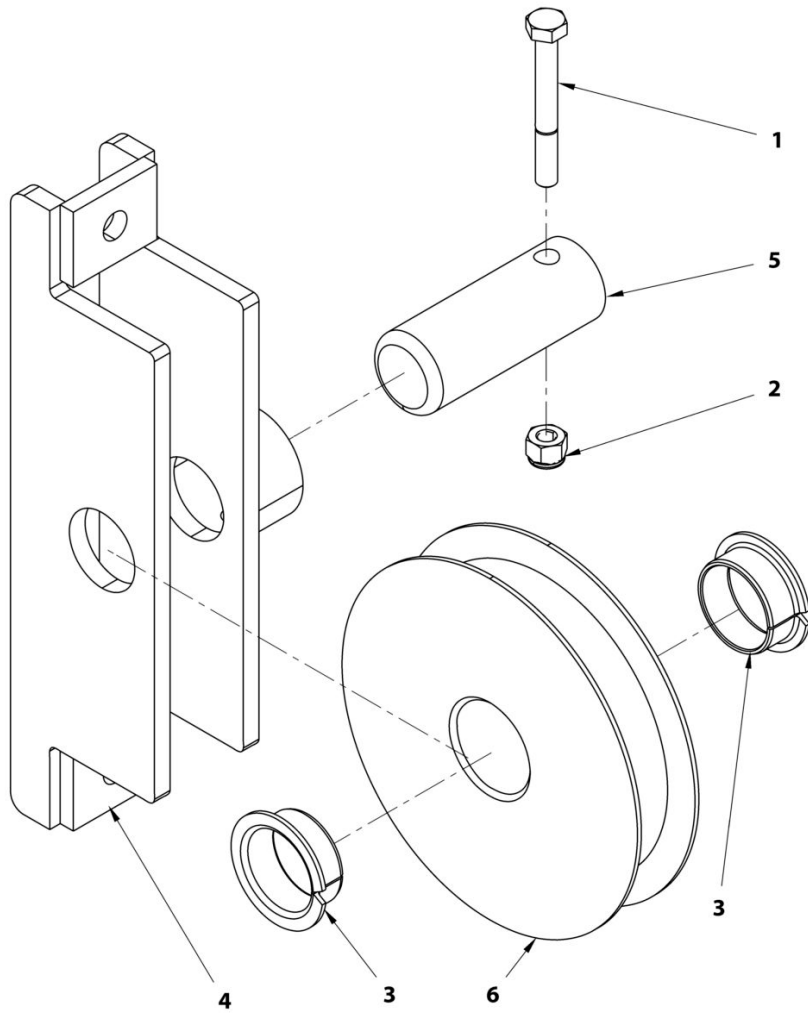

ART. 560730

SECTION 4 - MAST AND BOOM INSTALL / INSTALLATION MATS ET BRAS

FIGURE 4-2. PULLEY SUPPORT LL10-44 / SUPPORT POULIE LL10-44

ITEM	PART NUMBER	QTY	DESCRIPTION	REV
	SE0730		PULLEY SUPPORT LL10-44 / SUPPORT POULIE LL10-44	A
1	100013	1	M06x50 8.8 HEX HEAD CAPSCREW / VIS H M06x50 8.8 BI FP	
2	110003	1	M06 GR.08 LOCK NUT / ECROU FREIN M6 CL08 BI	
3	150011	2	FLANGE BUSHING D25 H11.5 DU / BAGUE EPAULEE D25 H11.5 DU	
4	SD0453	1	PULLEY MOUNT / SUPPORT POULIE	
5	US0377	1	PULLEY PIN / AXE DE SUPPORT POULIE	
6	US0475	1	LL10-44 PULLEY / POULIE LL10-44	

SECTION 4 - MAST AND BOOM INSTALL / INSTALLATION MATS ET BRAS

FIGURE 4-3. PULLEY SUPPORT LL12-66 / SUPPORT POULIE LL12-66

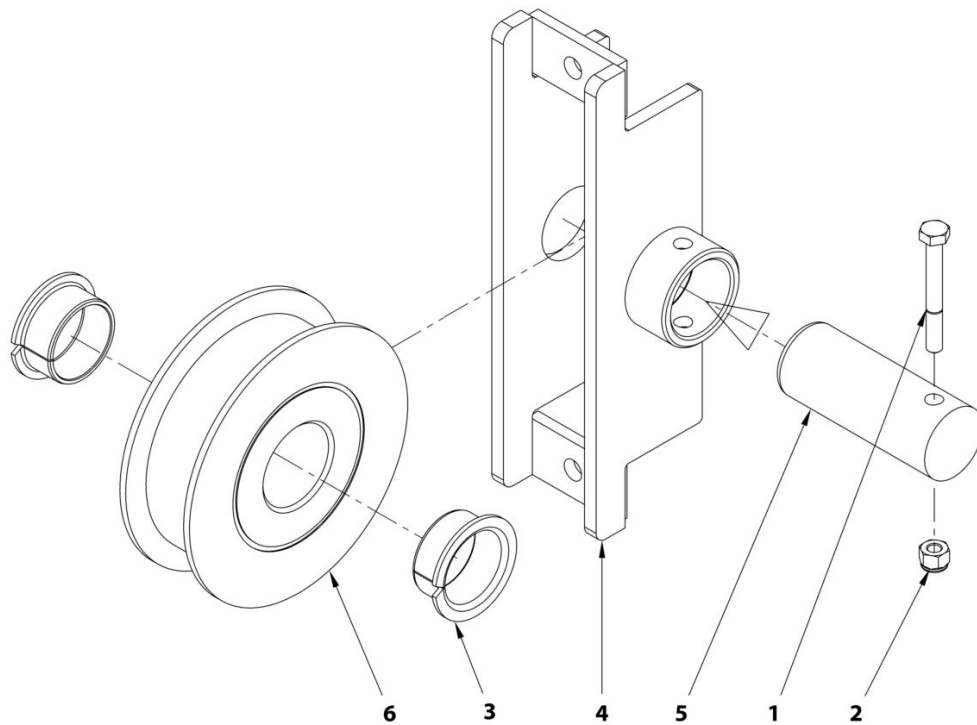

ART_SE0731

SECTION 4 - MAST AND BOOM INSTALL / INSTALLATION MATS ET BRAS

FIGURE 4-3. PULLEY SUPPORT LL12-66 / SUPPORT POULIE LL12-66

ITEM	PART NUMBER	QTY	DESCRIPTION	REV
	SE0731		PULLEY SUPPORT LL12-66 / SUPPORT POULIE LL12-66	A
1	100013	1	M06x50 8.8 HEX HEAD CAPSCREW / VIS H M06x50 8.8 BI FP	
2	110003	1	M06 GR08 LOCK NUT / ECROU FREIN M6 CL08 BI	
3	150007	2	FLANGE BUSHING Ø30 H16 DU / BAGUE EPAULEE Ø30 H16 DU	
4	SD0452	1	PULLEY MOUNT / SUPPORT POULIE	
5	US0375	1	PULLEY PIN / AXE DE SUPPORT POULIE	
6	US0479	1	LL12-66 PULLEY / POULIE LL12-66	

SECTION 5 - PLATFORM INSTALL / INSTALLATION PLATE-FORME

SECTION 5 - PLATFORM INSTALL / INSTALLATION PLATE-FORME

SECTION 5 - PLATFORM INSTALL / INSTALLATION PLATE-FORME

FIGURE 5-1. PLATFORM SUPPORT INSTALL / INSTALLATION SUPPORT PLATE-FORME

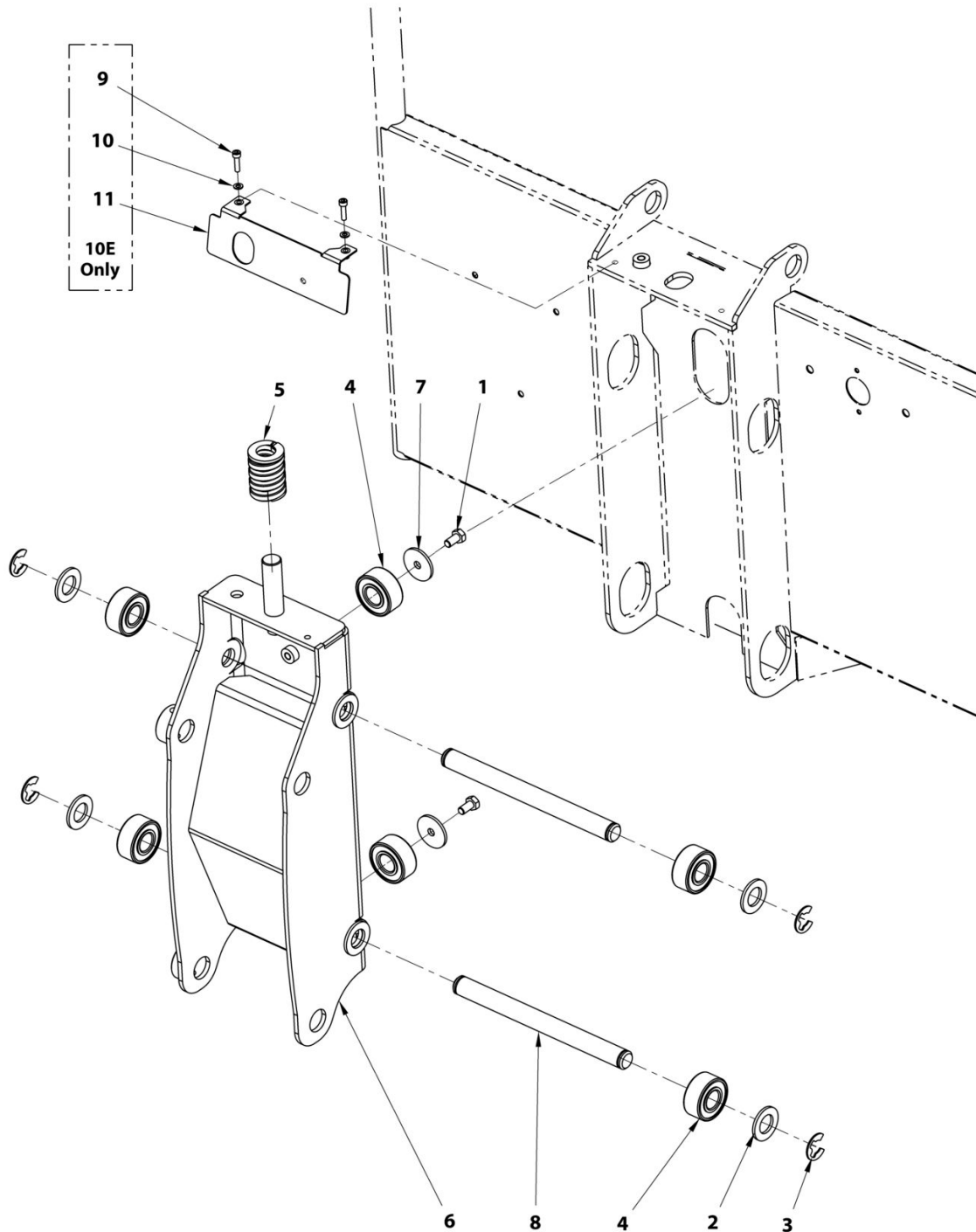

ART_1001277965

SECTION 5 - PLATFORM INSTALL / INSTALLATION PLATE-FORME

FIGURE 5-1. PLATFORM SUPPORT INSTALL / INSTALLATION SUPPORT PLATE-FORME

ITEM	PART NUMBER	QTY	DESCRIPTION	REV
	1001211420	Ref	26E-PLATFORM SUPPORT INSTALL / 26E-INSTALLATION SUPPORT PLATE-FORME	A
	1001277965	Ref	10E-PLATFORM SUPPORT INSTALL / 10E-INSTALLATION SUPPORT PLATE-FORME	A
1	100054	2	M08x16 8.8 HEX HEAD MACHINE SCREW / VIS H M08x16 8.8 BI FT	
2	120003	4	D20x37x3 WASHER / RONDELLE D20x37x3 BI	
3	130029	4	RETAINING RING D15 / CIRCLIPS EXTERIEUR D15	
4	150061	6	3204-2RS BEARING / ROULEMENT 3204-2RS	
5	160033	1	SPRING,OVERLOAD G 40-51 / RESSORT SURCHARGE G40-51	
6	DL0918	1	SUPPORT,PLATFORM / SUPPORT PLATE-FORME	
7	US0531	2	WASHER-SPEC,D8XD37XTH.3 / RONDELLE Di 8xDe 37xEP 3	
8	US0603	2	PIN,BEARING MOUNT / AXE ROULEMENTS	
9	000010	2	M05x20 8.8 SOCKET HEAD MACH SCREW / VIS CHC M05x20 BI FT (SN A300060685 to Present)	
10	120002	2	M05 WASHER / RONDELLE M05 (SN A300060685 to Present)	
11	1001276683	1	PLATE,LSS PROTECTION / CAPOT PROTECTION SURCHARGE (SN A300060685 to Present)	

SECTION 5 - PLATFORM INSTALL / INSTALLATION PLATE-FORME

FIGURE 5-2. PLATFORM, DROP BAR INSTALL / INSTALLATION PLATE-FORME - LISSE COULISSANTE

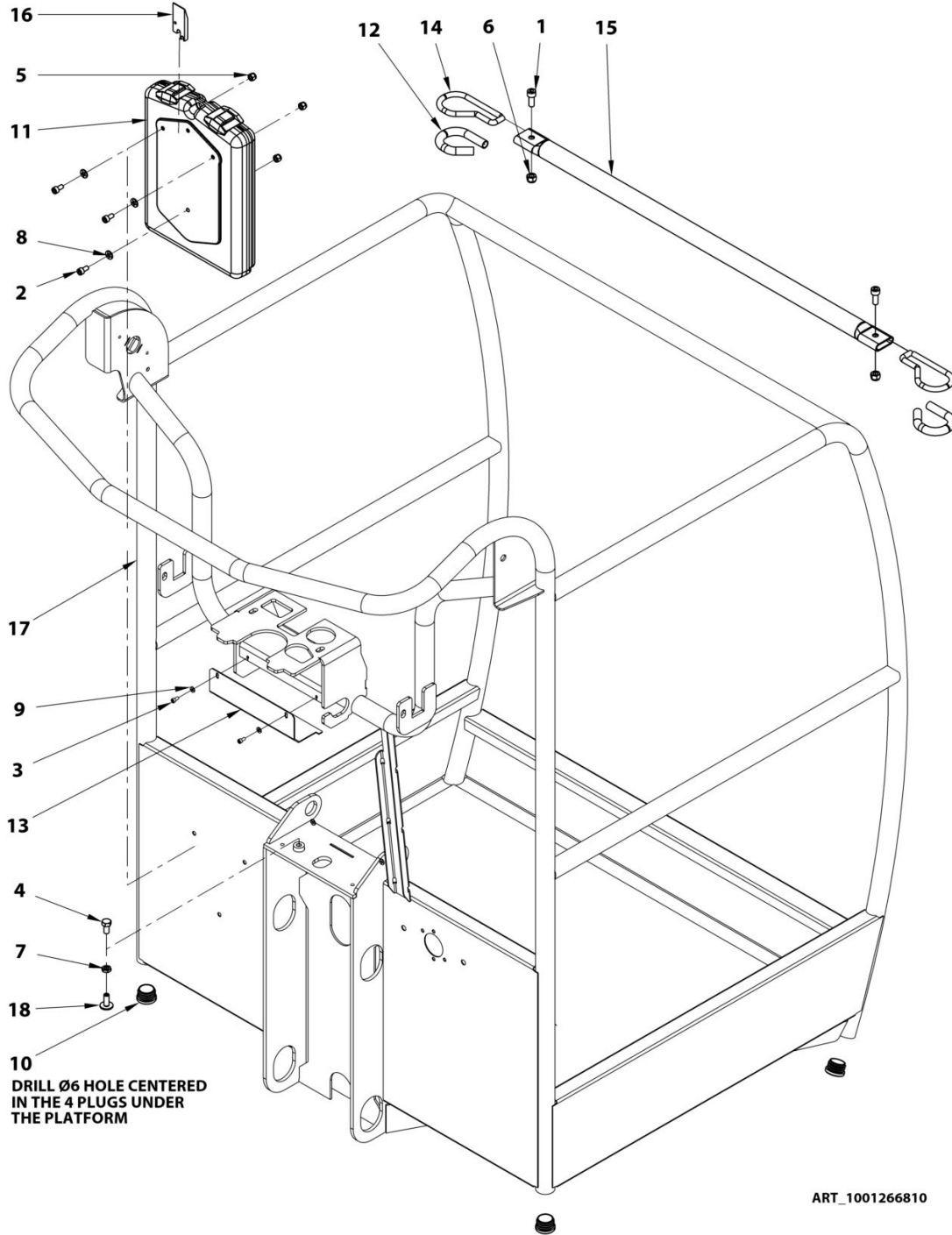

SECTION 5 - PLATFORM INSTALL / INSTALLATION PLATE-FORME

FIGURE 5-2. PLATFORM,DROP BAR INSTALL / INSTALLATION PLATE-FORME - LISSE COULISSANTE

ITEM	PART NUMBER	QTY	DESCRIPTION	REV
	1001266810	Ref	PLATFORM WITH DROP BAR INSTALL / INSTALLATION PLATE-FORME - LISSE COULISSANTE	A
1	000006	2	M08x20 8.8 SOCKET HEAD MACH SCREW / VIS CHC M08x20 8.8 BI FT	
2	000014	3	M06x12 8.8 SOCKET HEAD MACH SCREW / VIS CHC M06x12 8.8 BI FT	
3	000090	2	M04x08 8.8 SOCKET HEAD MACH SCREW / VIS CHC M04x08 8.8 BI FT	
4	100054	1	M08x16 8.8 HEX HEAD MACHINE SCREW / VIS H M08x16 8.8 BI FT	
5	110003	3	M06 GR. 8.8 LOCK NUT / ECROU FREIN M6 CL08 BI	
6	110004	2	M08 GR. 8.8 LOCK NUT / ECROU FREIN M8 CL08 BI	
7	110022	1	M08 GR. 8.8 FLAT HEX NUT / ECROU Hm M08 CL04 ZI	
8	120009	3	LOCK WASHER D06x14 / RONDELLE CONTACT dD 06x14 BI	
9	120024	2	LOCK WASHER D04x10 / RONDELLE CONTACT M4 BI	
10	400048	4	CAP D30 / BOUCHON D30	
11	8990147	1	HOLDER, MANUAL / BOITE PORTE-DOCUMENTS	
12	280023	0.36m	PROTECTION SLEEVE / GAINÉ DE PROTECTION	
13	1001266724	1	PLATE,CONNECTOR BOX COVER / CARTER DE PROTECTION CONNECTEURS	
14	ST0736	2	BAR, FLAP HOOP / ANNEAU PORTILLON	
15	ST0763	1	RAIL, FLAP / PORTILLON	
16	ST2741	1	SENSOR CONTROL TOOL / CALE DE VERIFICATION	
17	1001266736	1	PLATFORM,DROP BAR / PLATE-FORME A LISSE COULISSANTE	
18	US0236	1	SETTING SCREW / VIS DE REGLAGE	

SECTION 5 - PLATFORM INSTALL / INSTALLATION PLATE-FORME

FIGURE 5-3. PLATFORM, SALOON GATES / INSTALLATION PLATE-FORME - PORTE SALOON

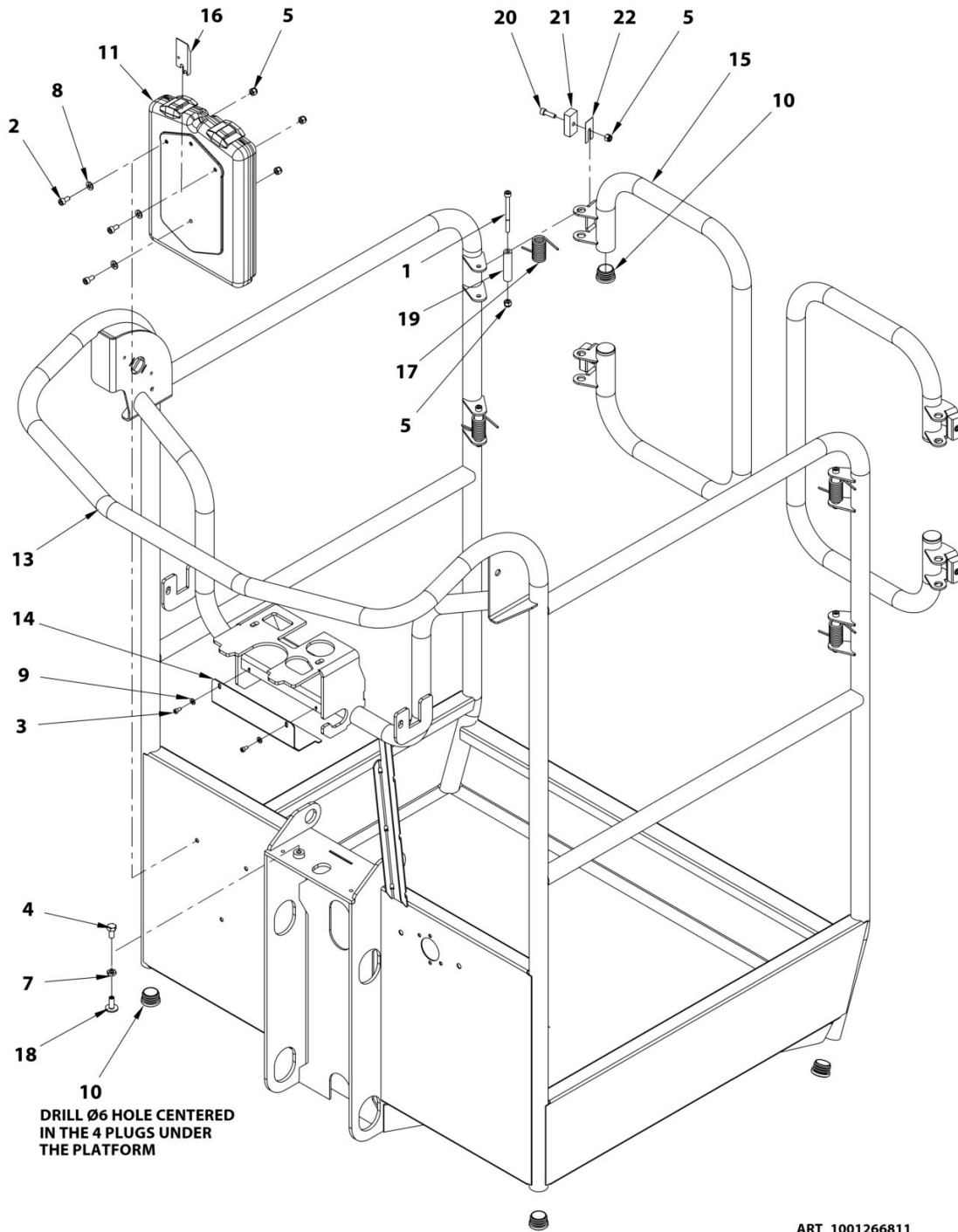

SECTION 5 - PLATFORM INSTALL / INSTALLATION PLATE-FORME

FIGURE 5-3. PLATFORM,SALOON GATES / INSTALLATION PLATE-FORME - PORTE SALOON

ITEM	PART NUMBER	QTY	DESCRIPTION	REV
	1001266811	Ref	INSTALL,PLATFORM,SALOON GATES / INSTALLATION PLATE-FORME - PORTE SALOON	B
1	000088	4	M06x70 8.8 SOCKET HEAD CAPSCREW / VIS CHC M06x70 8.8 BI FP	
2	000014	3	M06x12 8.8 SOCKET HEAD MACH SCREW / VIS CHC M06x12 8.8 BI FT	
3	000090	2	M04x08 8.8 SOCKET HEAD MACH SCREW / VIS CHC M4x08 8.8 BI FT	
4	100054	1	M08x16 8.8 HEX HEAD MACHINE SCREW / VIS H M08x16 8.8 BI FT	
5	110003	11	M06 GR. 8.8 LOCK NUT / ECROU FREIN M6 CL08 BI	
7	110022	1	M08 GR. 8.8 FLAT HEX NUT / ECROU Hm M08 CL04 ZI	
8	120009	3	LOCK WASHER D06x14 / RONDELLE CONTACT dD 06x14 BI	
9	120024	2	LOCK WASHER D04x10 / RONDELLE CONTACT M4 BI	
10	400048	8	CAP D30 / BOUCHON D30	
11	8990147	1	HOLDER, MANUAL / BOITE PORTE-DOCUMENTS	
13	1001266631	1	PLATFORM,SALOON GATES / PLATE-FORME A PORTE SALOON	
14	1001266724	1	PLATE,CONNECTOR BOX COVER / CARTER DE PROTECTION CONNECTEURS	
15	1001266813	2	GATE,SALOON / PORTE SALOON	
16	ST2741	1	SHIM, CHECKING / CALE DE VERIFICATION	
17	1001267022	4	SPRING,ANGULAR / RESSORT ANGULAIRE	
18	US0236	1	SCREW, ADJUSTMENT / VIS DE REGLAGE	
19	1001267401	4	PIN,SALOON GATE / AXE PORTE SALOON	
20	000005	4	M06x20 8.8 SOCKET HEAD MACH SCREW / VIS CHC M06x20 8.8 BI FT	
21	1001271848	4	PAD,SALOON GATE / PATIN BUTEE PORTE SALOON	
22	1001271849	AR	SHIM,PAD / CALE DE PATIN	

SECTION 5 - PLATFORM INSTALL / INSTALLATION PLATE-FORME

FIGURE 5-4. SKYLINE INSTALL / INSTALLATION SKYLINE

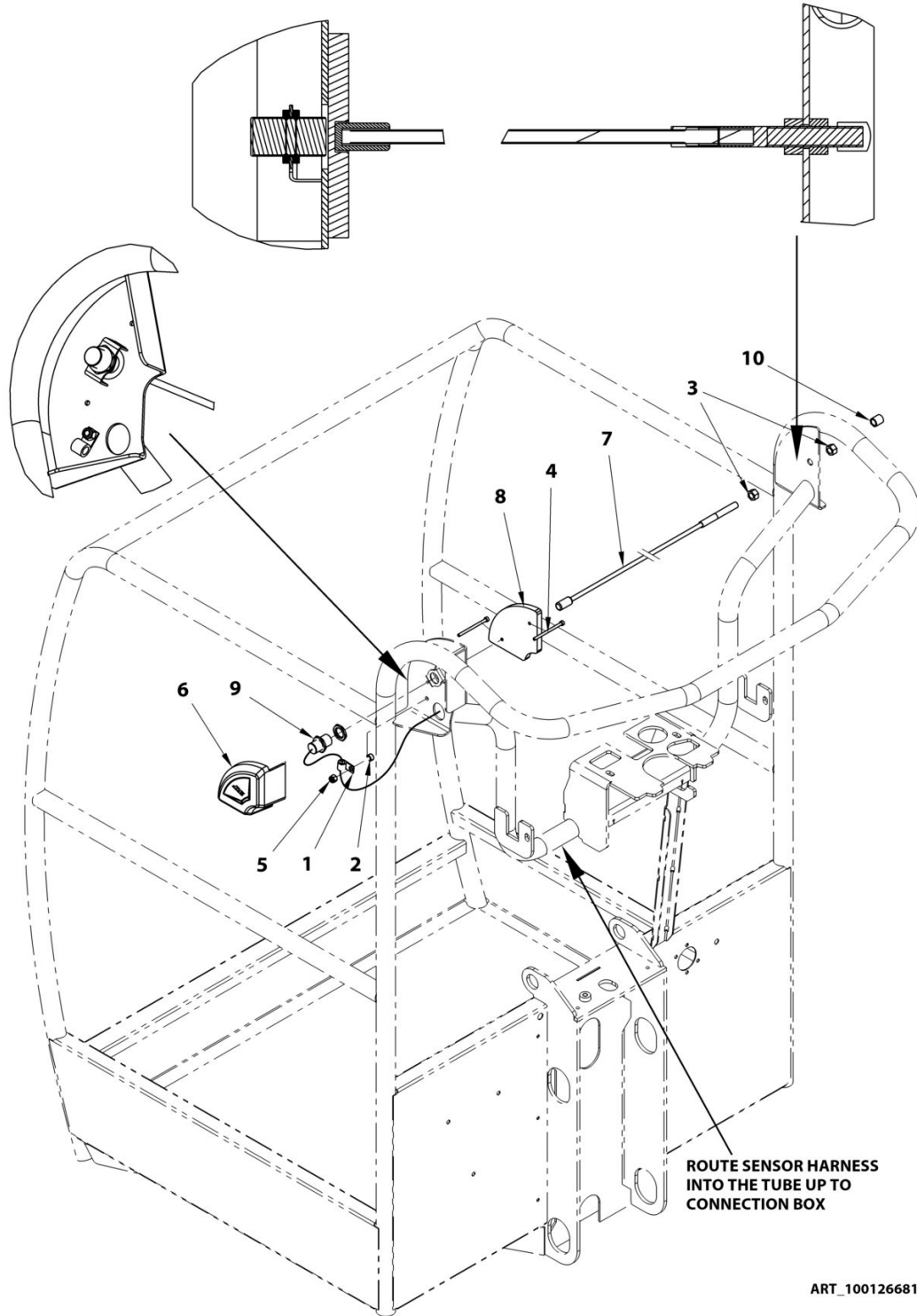

ART_1001266812

SECTION 5 - PLATFORM INSTALL / INSTALLATION PLATE-FORME

FIGURE 5-4. SKYLINE INSTALL / INSTALLATION SKYLINE

ITEM	PART NUMBER	QTY	DESCRIPTION	REV
	1001266812	Ref	INSTALL,SKYLINE / INSTALLATION SKYLINE	B
1	1321293	1	CLAMP,CABLE / COLLIER ISOLE	
2	000014	1	M06x12 8.8 SOCKET HEAD MACH SCREW / VIS CHC M06x12 8.8 BI FT	
3	3311601	2	NUT,3/8-16 HEX NUT / ECROU 3/8-16	
4	4031516	2	SOCKET HD CAP METRIC,4 X 60 / VIS CHC M04x60 8.8 BI FP	
5	110003	1	M06 GR. 8.8 LOCK NUT / ECROU FREIN M6 CL08 BI	
6	1001241965	1	HOUSING,SKYLINE RIGHT ASM / CAISSON DROIT SKYLINE	
7	1001254472	1	ROD,SKYGUARD ASSEMBLY / BARE SKYLINE	
8	1001254473	1	HOUSING,SKYLINE LEFT / CAISSON GAUCHE SKYLINE	
9	1001232667	1	SENSOR SKYLINE / DETECTEUR SKYLINE	
10	1001275523	1	CAP D9 / PROTECTION D9	

SECTION 5 - PLATFORM INSTALL / INSTALLATION PLATE-FORME

FIGURE 5-5. CONSOLE AND CONTAINER INSTALL / INSTALLATION BOITIER DE COMMANDE ET BOITE A OUTILS

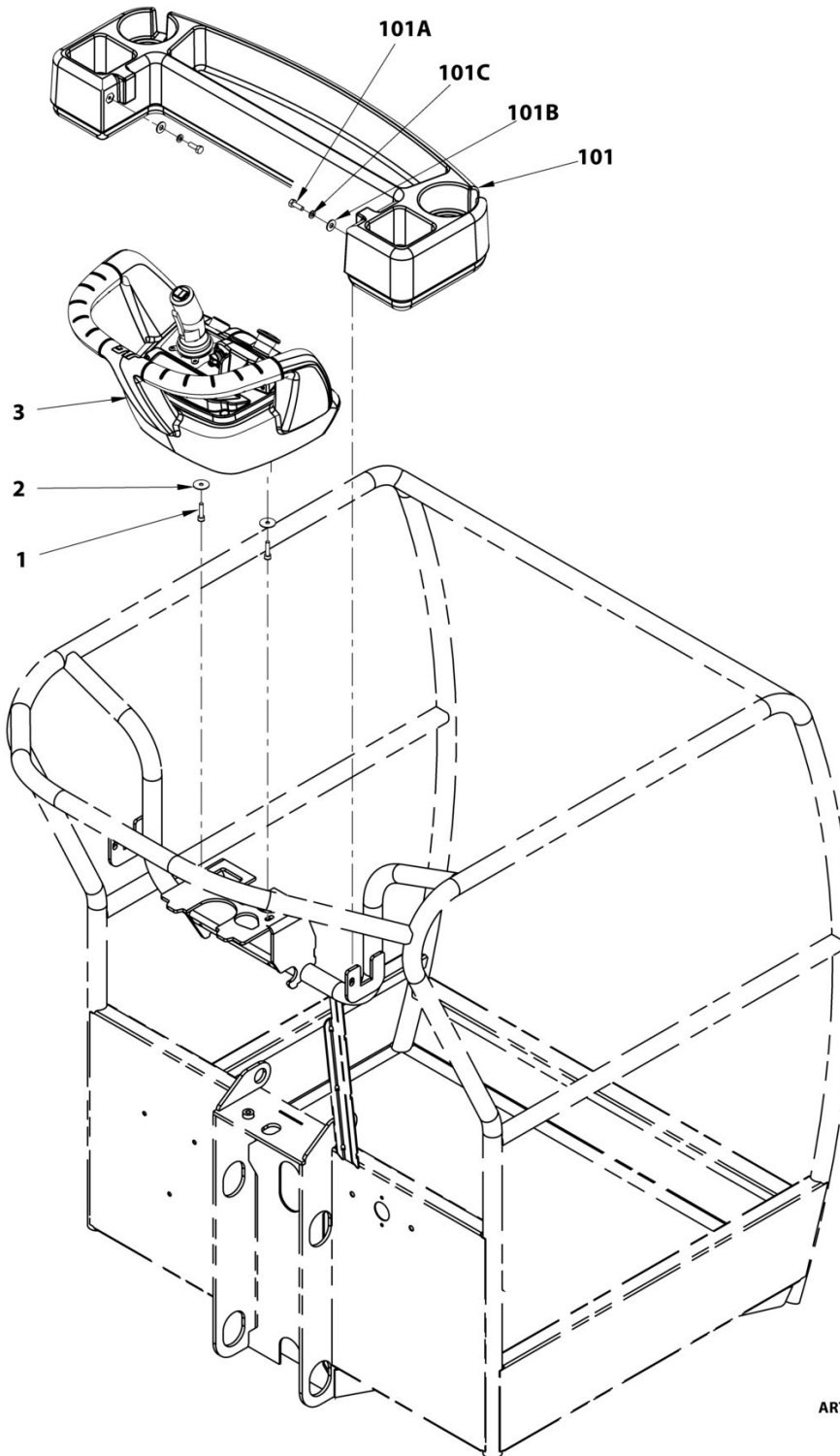

ART_1001209934

SECTION 5 - PLATFORM INSTALL / INSTALLATION PLATE-FORME

FIGURE 5-5. CONSOLE AND CONTAINER INSTALL / INSTALLATION BOITIER DE COMMANDE ET BOITE A OUTILS

ITEM	PART NUMBER	QTY	DESCRIPTION	REV
	1001209934	Ref	INSTALL,UPPER CONTROL BOX / ASSEMBLAGE BOITIER DE COMMANDE	B
1	000008	2	M06x25 8.8 SOCKET HEAD MACH SCREW / VIS CHC M06x25 8.8 BI FT	
2	120004	2	D06X25 LARGE WASHER / RONDELLE dD 06x25x1.2 BI	
3	1001266921	1	ELEC ASSY,PLATFORM CONTROL BOX / ASSEMBLAGE ELECTRIQUE, BOITIER DE COMMANDE	
	SA0020	Ref	INSTALL, CONTAINER STORAGE TRAY / INSTALLATION BOITE A OUTILS	B
101	1580012	1	CONTAINER, STORAGE TRAY / BOITE A OUTILS	
101A	0641406	2	HEX HD CAPSCREW, 1/4-20 x 3/4 LG / VIS H 1/4-20 x 3/4 LG	
101B	4751400	2	WASHER, 1/4" DIA PLAIN STL., WIDE / RONDELLE LARGE D, 1/4"	
101C	4761400	2	WASHER, 1/4" DIA ZINC PLT LOCK / RONDELLE FREIN D, 1/4" BI	

SECTION 5 - PLATFORM INSTALL / INSTALLATION PLATE-FORME

FIGURE 5-6. PLATFORM CONSOLE ASSEMBLY / BOITIER HAUT

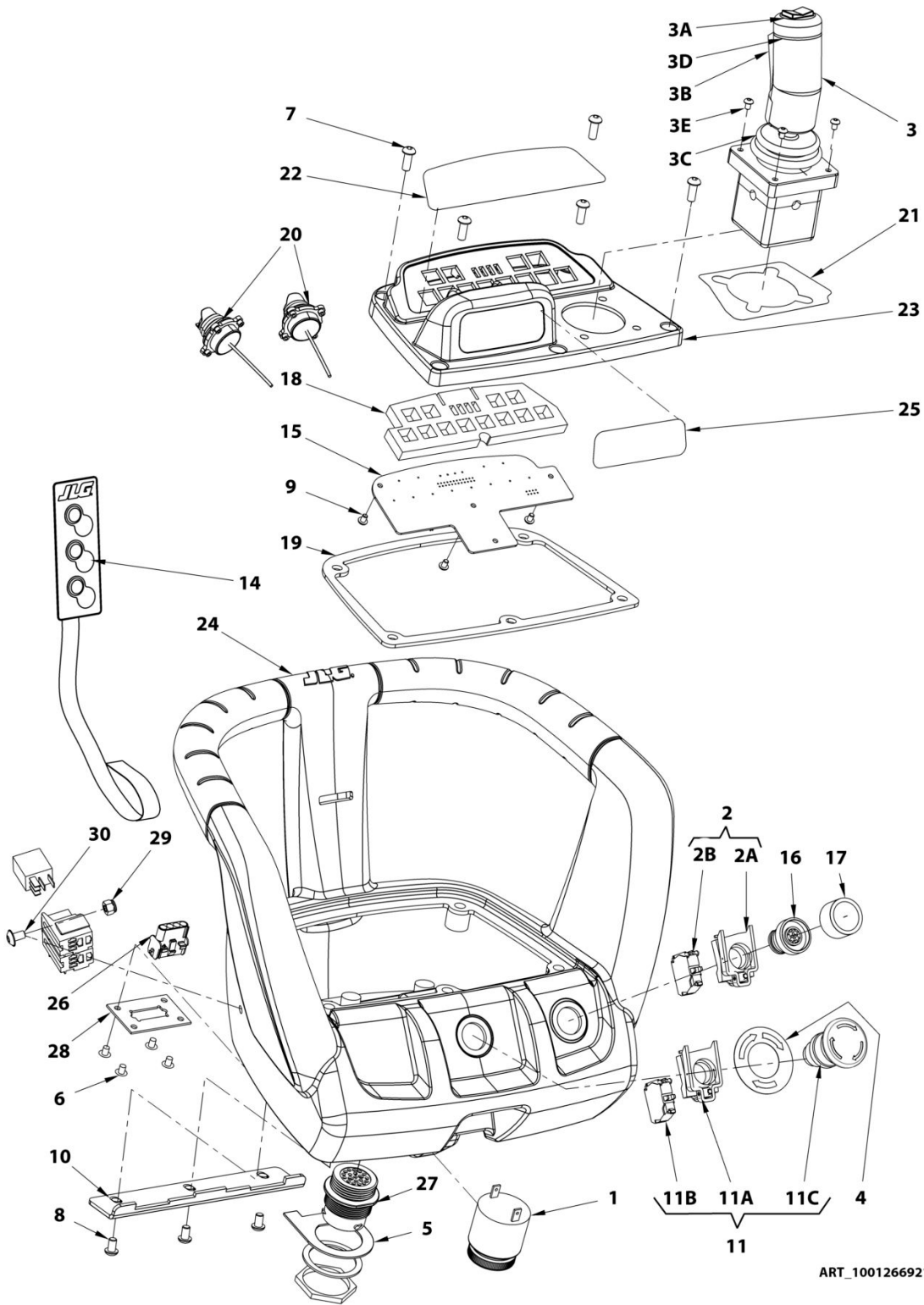

ART_1001266921

SECTION 5 - PLATFORM INSTALL / INSTALLATION PLATE-FORME

FIGURE 5-6. PLATFORM CONSOLE ASSEMBLY / BOITIER HAUT

ITEM	PART NUMBER	QTY	DESCRIPTION	REV
	1001266921		PLATFORM CONSOLE ASSEMBLY / BOITIER HAUT	B
1	0140011	1	AUDIBLE SIGNAL DEVICE / AVERTISSEUR SONORE	
2	240056	1	NO CONTACT BLOCK WITH HOLDER / EMBASE CONTACT NO	
2A	240076	1	CONTACT BLOCK HOLDER / EMBASE CONTACT	
2B	240058	1	NO CONTACT BLOCK / CONTACT NO	
3	1600458	1	JOYSTICK / JOYSTICK	
3A	70000084	1	CAP, RUBBER BOOT / PROTECTION CAOUTCHOUC	
3A	7027365	1	ACTUATOR HANDLE / ACTIONNEUR A BASCULE	
3B	7027367	1	SWITCH ENABLER / CONTACT VALIDATION	
3B	7027765	1	LEVER ENABLER / GACHETTE VALIDATION	
3C	70000682	1	RUBBER BELLOWS / SOUFFLET CAOUTCHOUC	
3D	7027766	1	BOOT RETAINING RING / ANNEAU DE BLOCAGE	
3E	130062	4	M04x16 8.8 ROUND HEAD MACH SCREW / VIS BOMBEE ULF M04x16 8.8 BI FT	
4	1706898	1	DECAL, EMERGENCY / AUTOCOLLANT ARRET D'URGENCE	
5	3575796	1	PLATE,D SLOT / PLAQUE ANTI-ROTATION	
6	3820019	4	RIVET, POP D4.75 L11.4 / RIVET POP D4.75 L11.4	
7	3900357	5	M06x16 10.9 BUTTON HEAD MACH SCREW / VIS BOMBEE ULF M06x16 10.9 BI FT	
8	3900358	3	M06x10 10.9 BUTTON HEAD MACH SCREW / VIS BOMBEE ULF M06x10 10.9 BI FT	
9	3900359	3	M04x06 10.9 BUTTON HEAD MACH SCREW / VIS BOMBEE ULF M04x06 10.9 BI FT	
10	4340871	1	MOUNT / BRIDE RENFORT	
11	4360562	1	COMPLETE KNOB / ARRET D'URGENCE COMPLET	
11A	240076	1	SWITCH BASE / EMBASE CONTACT	
11B	240057	1	NC CONTACT BLOCK / CONTACT NF	
11C	240060	1	TURN TO RELEASE KNOB / BOUTON D'ARRET D'URGENCE 1/4 TOUR	
14	1001266902	1	MEMBRANE 3 SWITCHES / MEMBRANE A 3 BOUTONS	
15	1001152692	1	CONTROLLER, PLATFORM MODULE / CARTE BOITIER HAUT PROGRAMMEE	
16	1001115919	1	SWITCH, PUSH BUTTON-ENABLE / BP DE VALIDATION	
17	1001117177	1	SWITCH,NEOPRENE BOOT / CAPUCHON D'ETANCHEITE NEOPRENE	
18	1001154560	1	SEAL,FORM SPACER GASKET / JOINT MOUSSE	
19	1001155328	1	SEAL,CONSOLE BOX LID / JOINT FACADE BOITIER HAUT	
20	1001155354	2	THUMB JOYSTICK / MINI JOYSTICK	
21	1001155460	1	DECAL,DRIVE SWING JOYSTICK / AUTOCOLLANT JOYSTICK TRANSLATION	
22	1001155462	1	DECAL,LIGHT PANEL ICON DISPLAY / AUTOCOLLANT INDICATEURS BOITIER HAUT	
23	1001157657	1	PANEL,CONSOLE COVER / PLATINE BOITIER HAUT	
24	1001266925	1	BOX,PLATFORM CONSOLE / BOITIER HAUT	
25	1001208856	1	DECAL,JIB,MAST JOYSTICK / AUTOCOLLANT JOYSTICK MAT ET BRAS	
26	1001208857	1	HARNESS,JOYSTICS / FAISCEAU JOYSTICKS	
27	1001266923	1	HARNESS UCB / FAISCEAU BOITIER HAUT	
28	ST3312	1	PLATE,PLUG MOUNT / PLATINE MONTAGE CONNECTEUR	
29	110003	1	M06 GR. 8.8 LOCK NUT / ECROU FREIN M6 CL08 BI	
30	1001256013	1	SCREW RD HD MACH,M6X10 / VIS TETE RONDE M06x10	

**SECTION 6 - POWER TRACKS AND CLAMPS INSTALL / INSTALLATION
CHAINES PORTE CABLES**

**SECTION 6 - POWER TRACKS AND CLAMPS INSTALL /
INSTALLATION CHAINES PORTE CABLES**

SECTION 6 - POWER TRACKS AND CLAMPS INSTALL / INSTALLATION CHAINES PORTE CABLES

FIGURE 6-1. POWER TRACKS AND CLAMPS INSTALL / INSTALLATION CHAINES PORTE CABLES

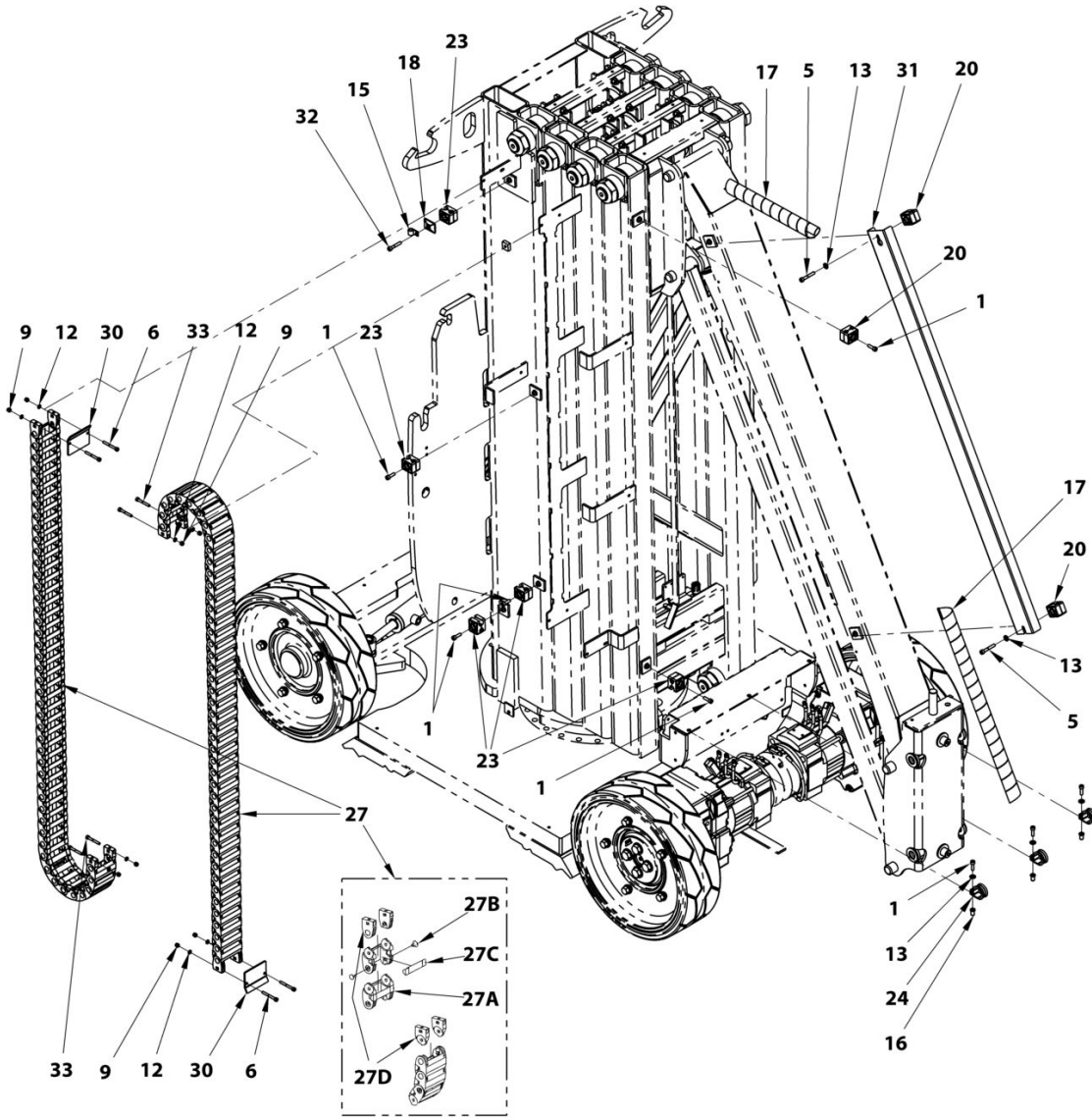

ART_1001211408

SECTION 6 - POWER TRACKS AND CLAMPS INSTALL / INSTALLATION CHAINES PORTE CABLES

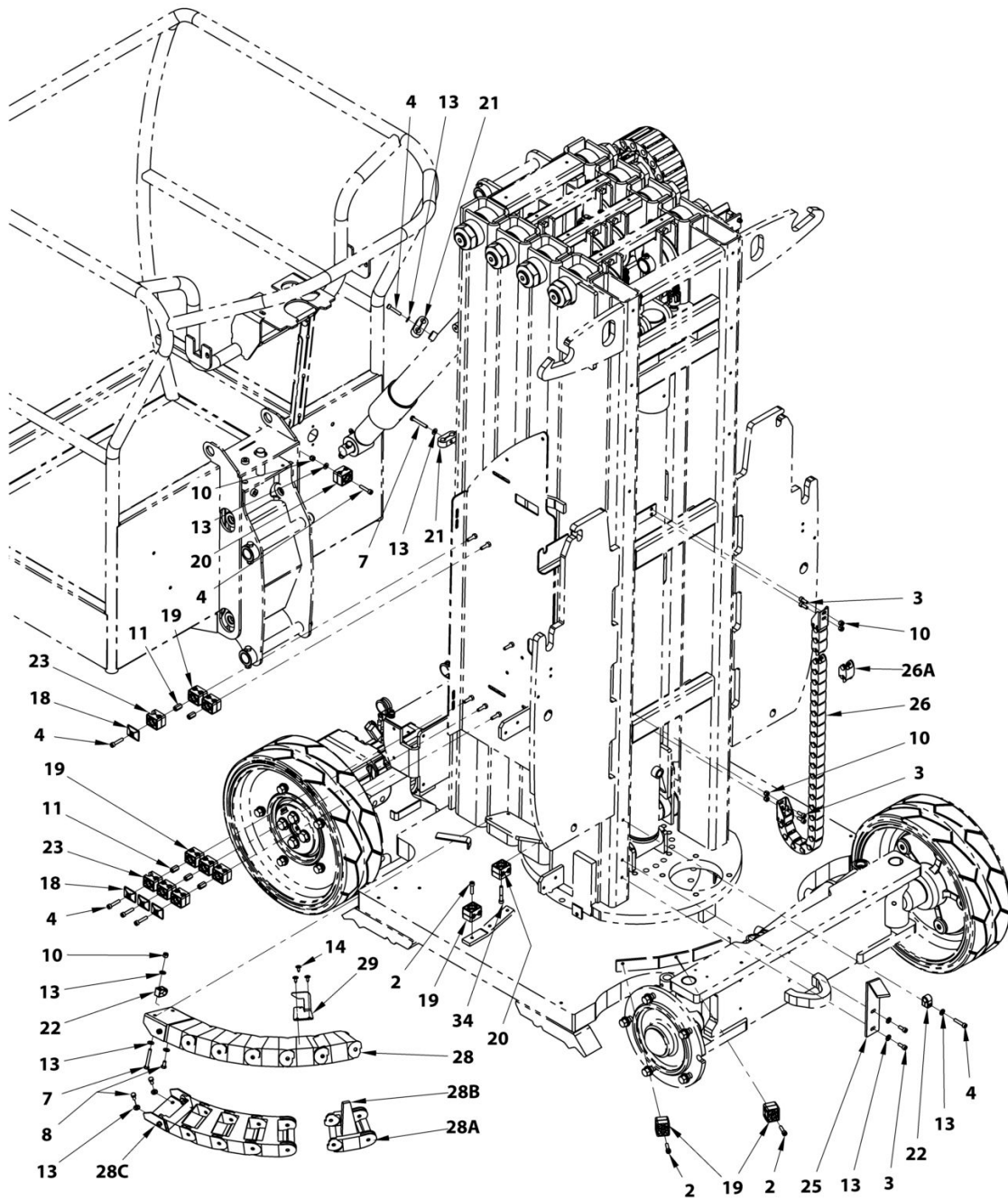

ART_1001211408-2

SECTION 6 - POWER TRACKS AND CLAMPS INSTALL / INSTALLATION CHAINES PORTE CABLES

FIGURE 6-1. POWER TRACKS AND CLAMPS INSTALL / INSTALLATION CHAINES PORTE CABLES

ITEM	PART NUMBER	QTY	DESCRIPTION	REV
	1001211408	Ref	POWER TRACK & CLAMPS INSTALL / INSTALLATION CHAINES PORTE CABLES	E
1	000005	8	M06x20 8.8 SOCKET HEAD MACH SCREW / VIS CHC M06x20 8.8 BI FT	
2	000008	3	M06x25 8.8 SOCKET HEAD MACH SCREW / VIS CHC M06x25 8.8 BI FT	
3	000015	6	M06x16 8.8 SOCKET HEAD MACH SCREW / VIS CHC M06x16 8.8 BI FT	
4	000016	7	M06x30 8.8 SOCKET HEAD MACH SCREW / VIS CHC M06x30 8.8 BI FT	
5	000017	2	M06x40 8.8 SOCKET HEAD MACH SCREW / VIS CHC M06x40 8.8 BI FT	
6	000051	4	M05x45 8.8 SOCKET HEAD CAPSCREW / VIS CHC M05x45 8.8 BI FP	
7	100004	2	M06x45 8.8 HEX HEAD MACHINE SCREW / VIS H M06x45 8.8 BI FT	
8	100027	3	M06x12 8.8 HEX HEAD MACHINE SCREW / H M06x12 8.8 BI FT	
9	110002	8	M05 GR. 8.8 LOCK NUT / ECROU FREIN M5 CL08 BI	
10	110003	6	M06 GR. 8.8 LOCK NUT / ECROU FREIN M6 CL08 BI	
11	110041	5	NUT,M6 EXTENSION / ECROU RALLONGE M6	
12	120002	8	M05 WASHER / RONDELLE M05 BI	
13	120009	16	LOCK WASHER D06x14 / RONDELLE CONTACT dD 06x14 BI	
14	130007	3	Ø4.8x13 SHEET METAL SCREW / VIS AUTOTARAUDEUSE D4.8-13 BI	
15	1321293	1	CLAMP,CABLE / COLLIER ISOLE	
16	1001258232	3	RIVET,NUT M6 / ECROU RIVET M6	
17	400010	0.8 m	HOSE GUARD / GAINE	
18	400012	5	PAIR 1/2 SHELL PLATE T1 / PLAQUE DE SERRAGE T1	
19	400018	10	CLAMP,TWIN 12-12 PP,BLK / COLLIER DOUBLE D12	
20	400037	5	CLAMP,TWIN 10-10 PP,BLK / COLLIER DOUBLE D10	
21	400046	2	CLAMP,TWIN 12-12 PP,BLK / COLLIER DOUBLE D12	
22	400047	2	CLAMP,SINGLE D12,BLK / COLLIER SIMPLE D12	
23	400092	7	CLAMP,TWIN 15-12 PP,BLK / COLLIER DOUBLE D12.7 / D15	
24	400096	3	CLAMP,DIA. 28mm / COLLIER D28 mm	
25	DL0828	1	BRACKET,POWER TRACK SUPPORT / SOUTIEN DE CHAINE PORTE-CABLES	
26	ST0838	1	POWER TRACK 27LINKS / CHAINE PORTE-CABLES 27 MAILLONS	
26A	920052	x	POWER TRACKS LINK / MAILLON CHAINE PORTE-CABLES	
27	ST1326	2	POWER TRACK 44 LINKS / CHAINE PORTE-CABLES 44 MAILLONS	
27A	920042	x	POWER TRACKS LINK / MAILLON CHAINE PORTE-CABLES	
27B	920045	x	POWER TRACKS PIN PG305 / AXE CHAINE PORTE-CABLES PG305	
27C	920046	x	POWER TRACKS COVER / CAPOT CHAINE PORTE-CABLES	
27D	920073	x	POWER TRACKS ATTACHMENT KIT SR305 / KIT ATTACHES CHAINE PORTE-CABLES SR305	
28	1001239742	1	POWER TRACK,CIRCULAR POWER BRIDGE / CHAINE PORTE-CABLES CIRCULAIRE	
28A	1001248510	x	POWER TRACK,LINK / MAILLON DE CHAINE CIRCULAIRE	
28B	1001248511	x	POWER TRACK,COVER / CLIP CHAINE CIRCULAIRE	
28C	1001248513	x	POWER TRACK,ATTACHMENT / ATTACHE CHAINE	

SECTION 6 - POWER TRACKS AND CLAMPS INSTALL / INSTALLATION CHAINES PORTE CABLES

ITEM	PART NUMBER	QTY	DESCRIPTION	REV
29	1001239741	1	CIRCULAIRE PLATE,POWER TRACK HOOK / SOUTIEN DE CHAINE PORTE- CABLES	
30	ST3219	2	PLATE,CABLES KEEPER / BRIDE DE CABLES	
31	ST3781	1	SHIELD,CABLE PROTECT,JIB / TOLE DE PROTECTION	
32	000077	1	M06x35 8.8 SOCKET HEAD CAPSCREW / VIS CHC M06x35 8.8 BI FP	
33	000030	4	M05x35 8.8 SOCKET HEAD CAPSCREW / VIS CHC M05x35 8.8 BI FP	
34	000026	1	M06x50 8.8 SOCKET HEAD CAPSCREW / VIS CHC M06x50 8.8 BI FP	

SECTION 7 - HYDRAULIC INSTALL / INSTALLATION HYDRAULIQUE

SECTION 7 - HYDRAULIC INSTALL / INSTALLATION HYDRAULIQUE

SECTION 7 - HYDRAULIC INSTALL / INSTALLATION HYDRAULIQUE

FIGURE 7-1. HOSES KIT DIAGRAM / SCHEMA KIT FLEXIBLES

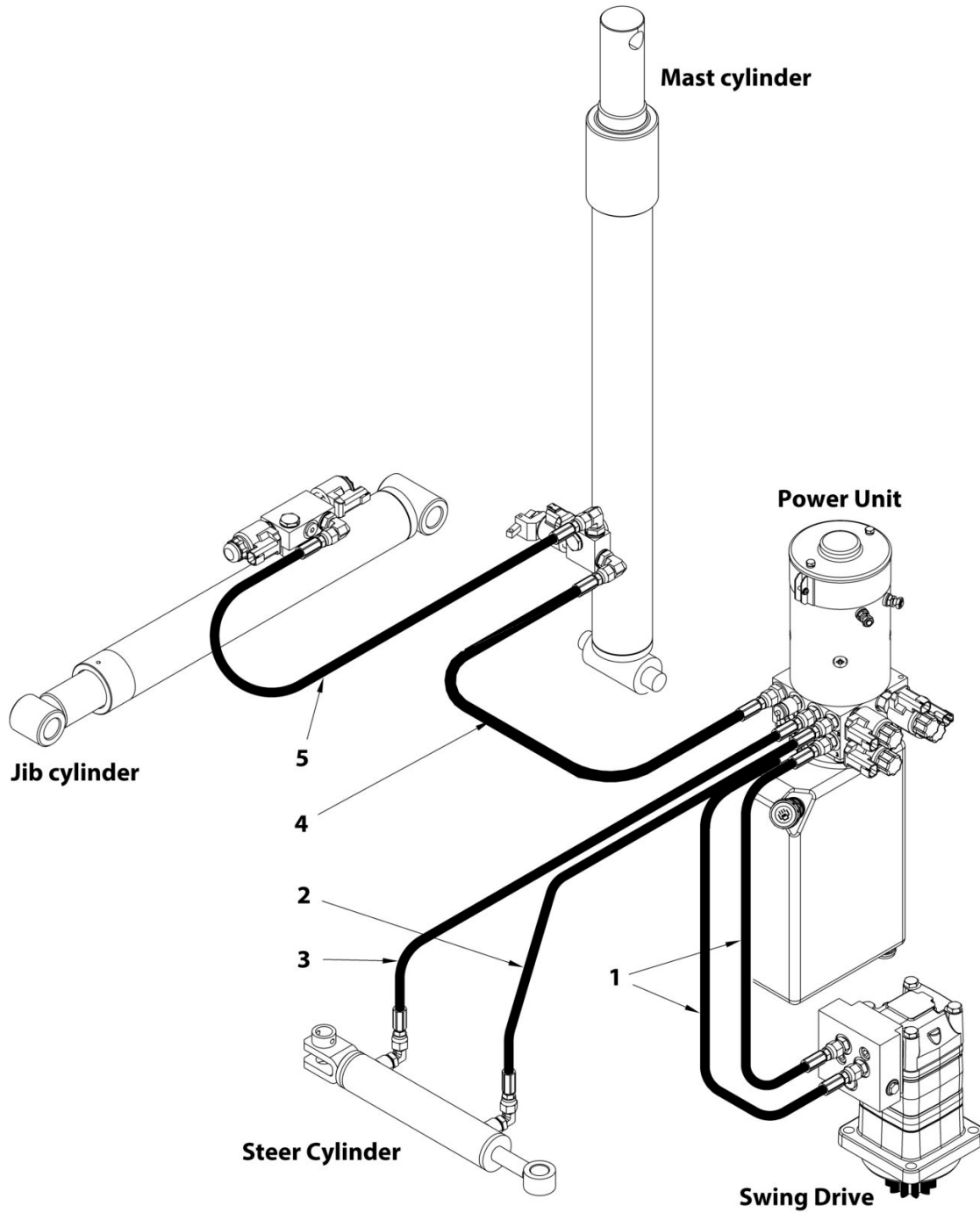

ART_KT0143

SECTION 7 - HYDRAULIC INSTALL / INSTALLATION HYDRAULIQUE

FIGURE 7-1. HOSES KIT DIAGRAM / SCHEMA KIT FLEXIBLES

ITEM	PART NUMBER	QTY	DESCRIPTION	REV
	KT0143	1	HOSES KIT / KIT FLEXIBLES	A
1	DF0269	2	HOSE 1/4-0150cm-JIC Fem 9/16-JIC Fem 9/16 / FLEXIBLE 1/4-0150cm-JIC Fem 9/16-JIC Fem 9/16	
2	DF0710	1	HOSE 1/4-0410cm-JIC Fem 9/16-JIC Fem 9/16-Yel-Blu / FLEXIBLE 1/4-0410cm-JIC Fem 9/16-JIC Fem 9/16-Jau-Ble	
3	DF0975	1	HOSE 1/4-0380cm-JIC Fem 9/16-JIC Fem 9/16 / FLEXIBLE 1/4-0380cm-JIC Fem 9/16-JIC Fem 9/16	
4	DF0976	1	HOSE 5/16-0200cm-JIC Fem 9/16-JIC Fem 9/16 / FLEXIBLE 5/16-0200cm-JIC Fem 9/16-JIC Fem 9/16	
5	DF0977	1	HOSE 5/16-0880cm-JIC Fem 9/16-JIC Fem 9/16 / FLEXIBLE 5/16-0880cm-JIC Fem 9/16-JIC Fem 9/16	

SECTION 7 - HYDRAULIC INSTALL / INSTALLATION HYDRAULIQUE

FIGURE 7-2. CONTROL VALVES INSTALL / INSTALLATION DISTRIBUTEURS

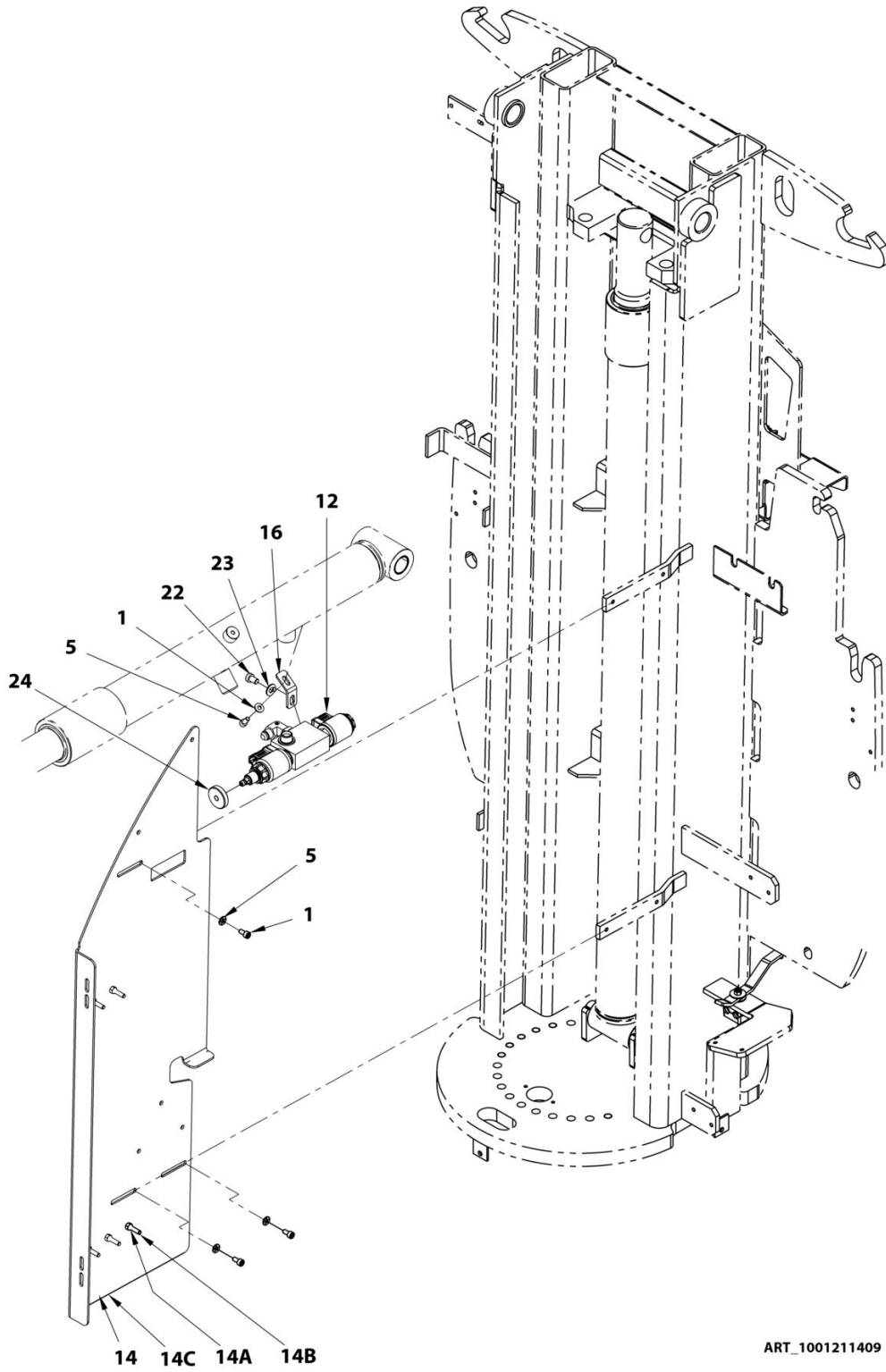

SECTION 7 - HYDRAULIC INSTALL / INSTALLATION HYDRAULIQUE

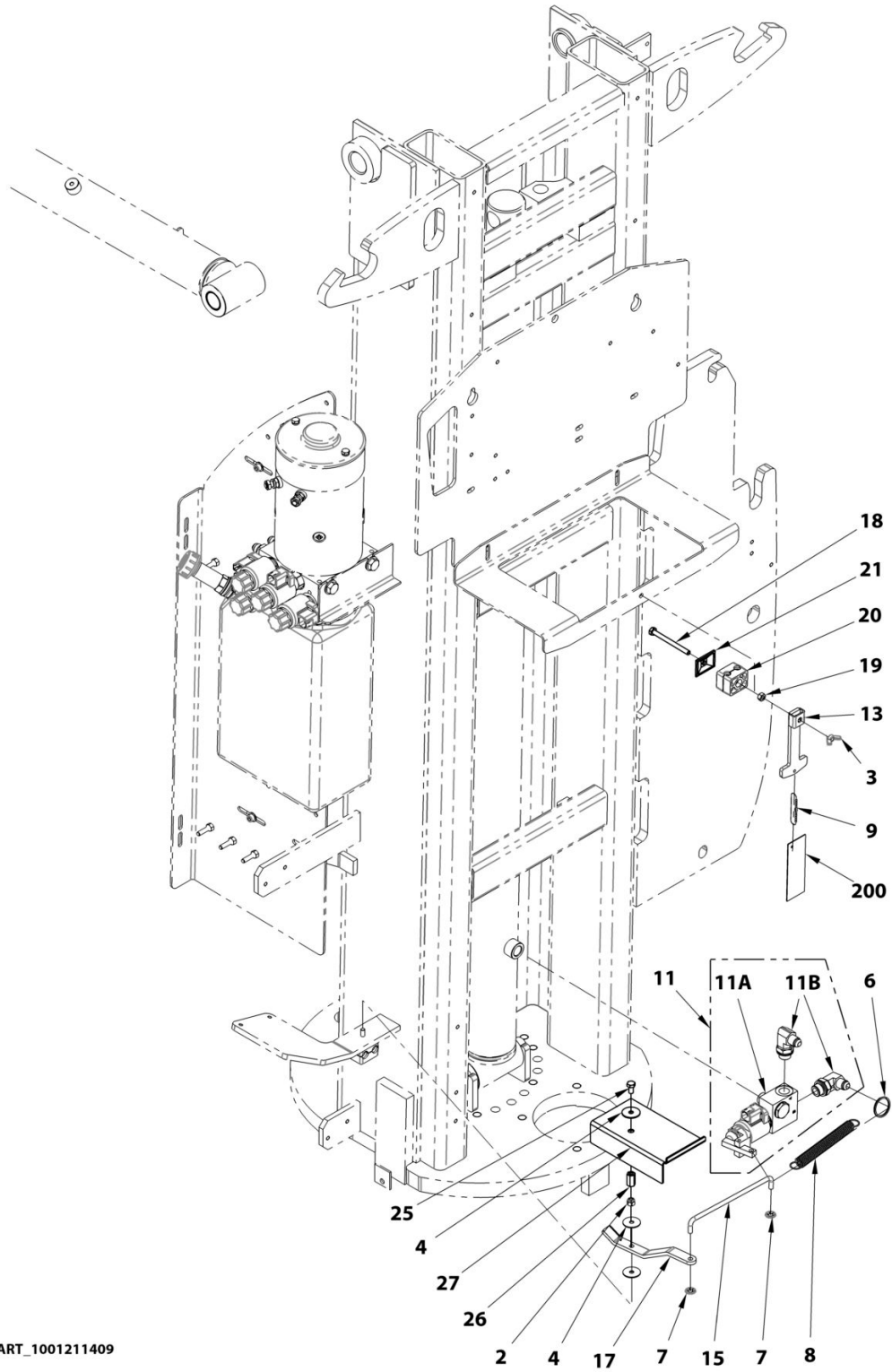

ART_1001211409

SECTION 7 - HYDRAULIC INSTALL / INSTALLATION HYDRAULIQUE

FIGURE 7-2. CONTROL VALVES INSTALL / INSTALLATION DISTRIBUTEURS

ITEM	PART NUMBER	QTY	DESCRIPTION	REV
	1001211409	Ref	CONTROL VALVES INSTALL / INSTALLATION DISTRIBUTEURS	D
1	000014	4	M06x12 8.8 SOCKET HEAD MACH SCREW / VIS CHC M06x12 8.8 BI FT	
2	110003	1	M06 GR. 8.8 LOCK NUT / ECROU FREIN M6 CL08 BI	
3	110042	1	WING NUT, M6 / ECROU A OREILLE M6	
4	120004	3	dD 06x25x1.2 WASHER / RONDELLE dD 06x25x1.2 BI	
5	120009	4	LOCK WASHER D06x14 / RONDELLE CONTACT dD 06x14 BI	
6	140014	1	LOCKING PIN RING / ANNEAU INDEX	
7	140024	2	WASHER-SPEC,PUSH-ON RETAINING / RONDELLE AUTO-BLOQUANTE D6	
8	160018	1	SPRING,TRACTION 160 140 1000 I / RESSORT DE TRACTION 160 140 1000 I	
9	190077	1	CHAIN,METAL BALL / CHAINE A BILLES METAL	
11	1001216725	1	VALVE ASSY,MAST CYL / ASSEMBLAGE DISTRIBUTEUR VERIN MAT	
11A	520115	1	VALVE,MAST CYL. HOLDING W/ FLOW REG,HYDAC / DIST. VERIN MAT AVEC REGULATEUR DE DEBIT	
11B	300061	2	90° ELBOW MALE BSPP 3/8-MALE JIC 9/16 / COUDE 90° MALE BSPP3/8-MALE JIC9/16	
12	1001222936	1	VALVE ASSY,JIB CYL / ASSEMBLAGE DISTRIBUTEUR VERIN BRAS	
13	DL0911	1	LEVER,BREAKDOWN CONTROLS / LEVIER DE CONTROLE SECOURS	
14	SE1204	1	HINGE MOUNT PLATE WITH STUDS / SUPPORT CHARNIERES AVEC GOUJONS	
14A	110015	6	M06 GR. 8.8 HEX NUT / ECROU H M06 CL08 BI	
14B	130066	6	STUD,SELF-CRIMPING,M6x30 / GOUJON A SERTIR M06x30	
14C	ST3780	1	MOUNT,HINGE / TOLE CHARNIERE	
15	ST3231	1	LINK,MANUAL DESCENT / TRINGLE, DESCENTE MANUELLE	
16	1001225530	1	VALVE GUARD / PROTECTION VALVE VERIN	
17	ST3703	1	LEVER,MANUAL DESCENT / LEVIER, DESCENTE MANUELLE	
18	100049	1	M06x70 8.8 HEX HEAD MACHINE SCREW / VIS H M06x70 8.8 BI FP	
19	110015	1	M06 GR. 8.8 HEX NUT / ECROU H M06 CL08 BI	
20	400037	1	CLAMP,TWIN 10-10 PP,BLK / COLLIER DOUBLE D10	
21	400012	1	COVER PLATE CLAMP / BRIDE COLLIER	
22	000059	1	M08x12 8.8 SOCKET HEAD MACH SCREW / VIS CHC M08x12 8.8 BI FT	
23	120010	1	LOCK WASHER D08x18 / RONDELLE CONTACT dD 08x18 BI	
24	US0277	1	CYLINDER EMERGENCY BUTTON / BOUTON DE SECOUR VERIN	
25	100027	1	M06x12 8.8 HEX HEAD MACHINE SCREW / VIS H M06x12 8.8 BI FT	
26	110041	1	NUT,M6 h=18mm / ECROU M6 h=18mm	
27	1001237382	1	COVER,MAST MANUAL DESCENT / PROTECTION DESCENTE MAT	
200	AU2215	1	DECAL,SLACK CHAIN DETECTION / AUTOCOLLANT MOU DE CHAINE	

SECTION 7 - HYDRAULIC INSTALL / INSTALLATION HYDRAULIQUE

FIGURE 7-3. TANK AND PUMP INSTALL / INSTALLATION GROUPE HYDRAULIQUE

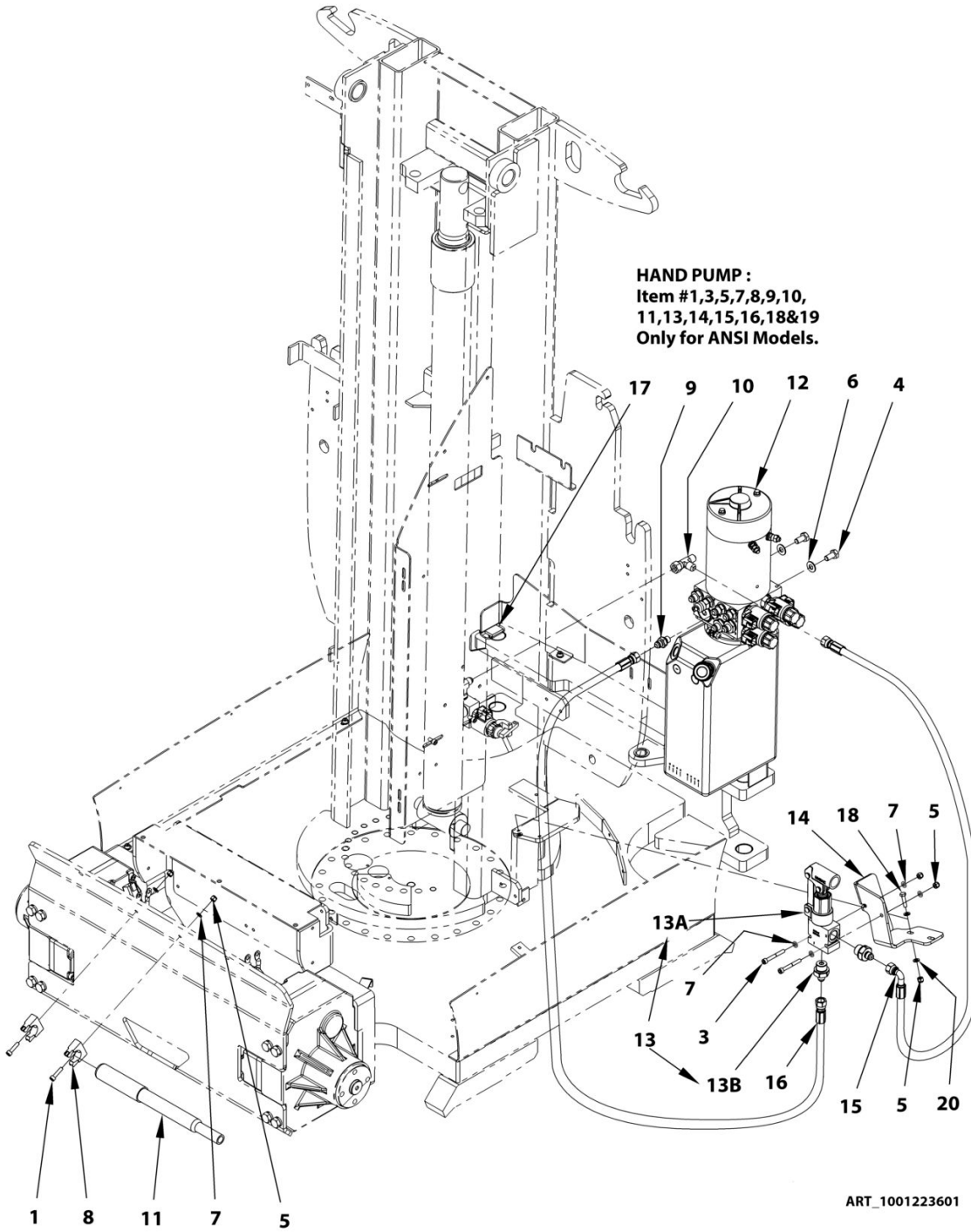

ART_1001223601

SECTION 7 - HYDRAULIC INSTALL / INSTALLATION HYDRAULIQUE

FIGURE 7-3. TANK AND PUMP INSTALL / INSTALLATION GROUPE HYDRAULIQUE

ITEM	PART NUMBER	QTY	DESCRIPTION	REV
	1001223601	Ref	26E-INSTALL,TANK & PUMP (HAND PUMP) / 26E-INSTALLATION GROUPE (POMPE A MAIN)	C
1	000008	2	M06x25 8.8 SOCKET HEAD MACH SCREW / VIS CHC M06x25 8.8 BI FT	
3	000026	2	M06x50 8.8 SOCKET HEAD CAPSCREW / VIS CHC M06x50 8.8 BI FP	
4	100156	2	M10x20 8.8 HEX HEAD MACHINE SCREW / VIS H M10x20 8.8 BI FT	
5	110003	5	M06 GR. 8.8 LOCK NUT / ECROU FREIN M6 CL08 BI	
6	120011	2	LOCK WASHER D10x22 / RONDELLE CONTACT dD 10x22 BI	
7	120030	6	LOCK WASHER D06x12 / RONDELLE CONTACT dD 06x12 BI	
8	190027	2	Ø22 CLIP / CLIP Ø22	
9	300025	1	FITTING MALE BSPP1/4-MALE JIC9/16 / RACCORD MALE BSPP1/4-MALE JIC9/16	
10	300037	1	RUN TEE JIC 9/16 SWIVEL NUT / TE ECROU TOURNANT JIC 9/16	
11	310109	1	LEVER,HAND PUMP / MANCHE POMPE A MAIN	
12	1001222935	1	PUMP,MOTOR/TANK / GROUPE HYDRAULIQUE	
13	1001222937	1	PUMP,HAND PUMP ASSEMBLY / ASSEMBLAGE POMPE A MAIN	
13A	1001225624	1	PUMP,HAND PUMP / POMPE A MAIN	
13B	300044	2	FITTING MALE BSPP 1/2-MALE JIC 9/16 / RACCORD MALE BSPP 1/2-MALE JIC 9/16	
14	1001223713	1	PLATE,HAND PUMP SUPPORT / SUPPORT POMPE A MAIN	
15	1001223897	1	HOSE,5/16" 105cm-FEM JIC 9/16-90° FEM JIC 9/16 / FLEXIBLE 5/16" 105cm-FEM JIC 9/16-90° FEM JIC 9/16	
16	1001223898	1	HOSE,5/16" 117cm-FEM JIC 9/16 / FLEXIBLE 5/16" 117cm-FEM JIC 9/16	
17	ST3318	1	STOP,RUBBER STICK / BUTEE ELASTIQUE ADHESIVE	
18	100012	1	M06x25 8.8 HEX HEAD MACH SCREW / VIS H M06x25 8.8 BI FT	
20	120016	2	WASHER D06x12 / RONDELLE D06x12	
	1001211321	Ref	10E-INSTALL,TANK & PUMP (W/O HAND PUMP) / 10E-INSTALLATION GROUPE (SANS POMPE A MAIN)	B
4	100156	2	M10x20 8.8 HEX HEAD MACHINE SCREW / VIS H M10x20 8.8 BI FT	
6	120011	2	LOCK WASHER D10x22 / RONDELLE CONTACT dD 10x22 BI	
12	1001222935	1	PUMP,MOTOR/TANK / GROUPE HYDRAULIQUE	
17	ST3318	1	STOP,RUBBER STICK / BUTEE ELASTIQUE ADHESIVE	

SECTION 7 - HYDRAULIC INSTALL / INSTALLATION HYDRAULIQUE

FIGURE 7-4. PUMP-MOTOR-TANK ASSEMBLY / GROUPE HYDRAULIQUE

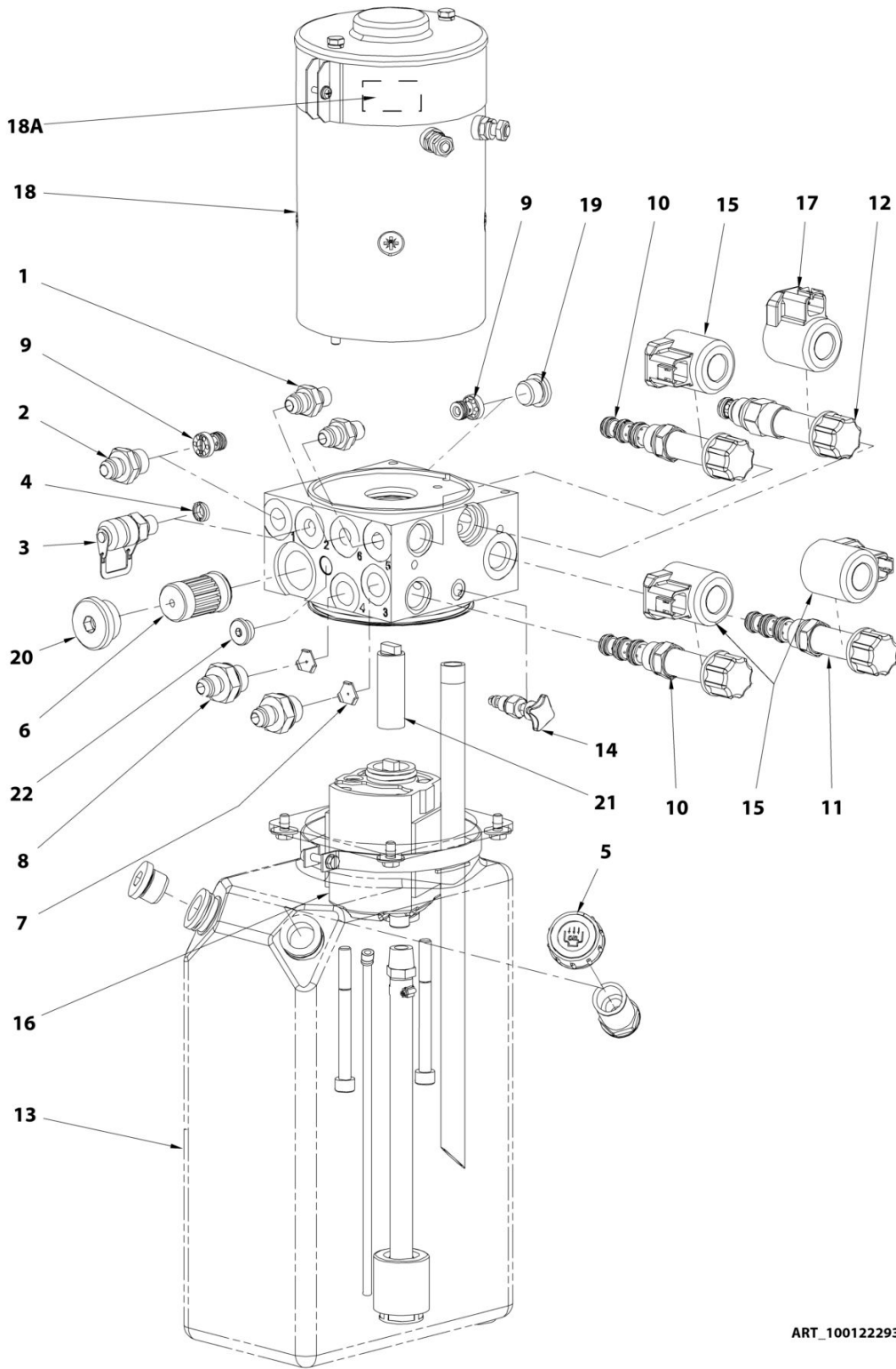

ART_1001222935

SECTION 7 - HYDRAULIC INSTALL / INSTALLATION HYDRAULIQUE

FIGURE 7-4. PUMP-MOTOR-TANK ASSEMBLY / GROUPE HYDRAULIQUE

ITEM	PART NUMBER	QTY	DESCRIPTION	REV
	1001222935		PUMP, -MOTOR-TANK ASSEMBLY / GROUPE HYDRAULIQUE	C
1	300025	2	FITTING MALE BSPP1/4-MALE JIC9/16 / RACCORD MALE BSPP1/4-MALE JIC9/16	
2	300040	1	FITTING MALE BSPP3/8 MALE JIC9/16 / RACCORD MALE BSPP3/8 MALE JIC9/16	
3	300101	1	PRESSURE TEST PLUG BSPP1/4 / PRISE DE PRESSION BSPP1/4	
4	310091	1	SEEVE 1/4 BSPP MESH 0.1mm / TAMIS 1/4 BSPP MAILLE 0.1mm	
5	310103	1	BREATHER CAP / BOUCHON-RENIFLARD	
6	930134	1	FILTER, CARTRIDGE,10µm / ELEMENT FILTRANT 10µm	
7	930135	2	VALVE, JET / LIMITEUR DE DEBIT	
8	930136	2	ADPT, ST S JIC/MPP 6-M18 FG / RACCORD M18x150 JIC 9/16	
9	930138	2	CHECK VALVE / CLAPET A BILLE	
10	952094	2	4/2 SOLENOÏD DIRECTIONAL VALVEWK08Z / DISTRIBUTEUR 4/2 WK08Z	
11	952095	1	4/2 SOLENOÏD DIRECTIONAL VALVEWK08Y / DISTRIBUTEUR 4/2 WK08Y	
12	952096	1	PROPORTIONAL RELIEF VALVE-PDB08P / LIMITEUR DE PRESSION PROPORTIONNEL PDB08P	
13	952097	1	TANK, PLASTIC_6 LITERS / RESERVOIR PLASTIQUE 6 Litres	
14	952098	1	VALVE, NEEDLE,BUILD_IN / ROBINET	
15	952099	3	COIL, 24VDC_3012599 / BOBINE 24VDC_3012599	
16	952100	1	PUMP, GEAR PUMP 3, 1CC/REV / POMPE 3.1CC/Tr	
17	952101	1	COIL, 24VADC_3110057 / BOBINE 24VADC_3110057	
18	970065	1	MOTOR, 24VDC 3KW, AMK5542 / MOTEUR, 24VDC 3KW,AMK5542	
18A	951034	1	BRUSH KIT FOR AMK 5542 / KIT BALAIS DE CHARBON AMK 5542	
19	300047	1	CAP BSPP 3/8 / BOUCHON BSPP 3/8	
20	952108	1	FITTING,CAP M27x0.75 / BOUCHON M27x0.75	
21	1001215691	1	COUPLING,PUMP / MOTOR / ACCOUPLEMENT POMPE / MOTEUR	
22	300034	1	CAP MALE BSPP 1/4" / BOUCHON MALE BSPP 1/4"	

SECTION 7 - HYDRAULIC INSTALL / INSTALLATION HYDRAULIQUE

FIGURE 7-5. VALVE ASSY,MAST CYLINDER / ASSEMBLAGE DISTRIBUTEUR VERIN MAT

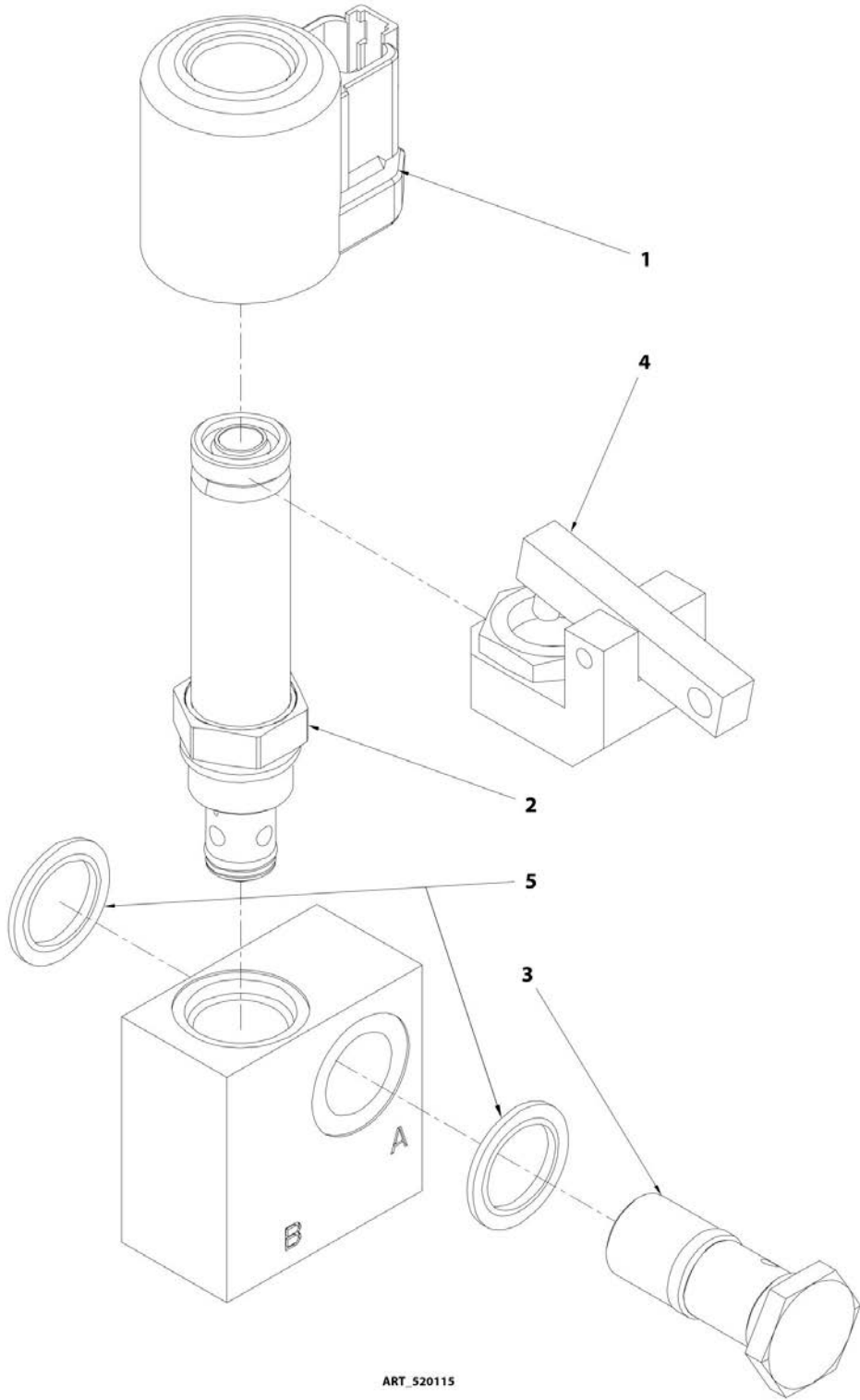

SECTION 7 - HYDRAULIC INSTALL / INSTALLATION HYDRAULIQUE

FIGURE 7-5. VALVE ASSY,MAST CYLINDER / ASSEMBLAGE DISTRIBUTEUR VERIN MAT

ITEM	PART NUMBER	QTY	DESCRIPTION	REV
	520115		VALVE, CYL. HOLDING WITH FLOW REGULATOR / DIST. VERIN AVEC REGULATEUR DE DEBIT	C
1	952099	1	COIL, 24VDC_3012599 / BOBINE 24VDC_3012599	
2	952102	1	2/2 SOLENOÏD DIRECTIONAL VALVE / DISTRIBUTEUR 2/2 WS08W	
3	952104	1	VALVE, FLOW REGULATOR-9L/MN / REGULATEUR DE DEBIT 9L/MN	
4	952106	1	MANUAL OVERRIDE SUPPORT, / COMMANDE MANUELLE	
5	952107	2	BS RING_HN48-10-U 16x24.7x1.5 St/NBR / BAGUE BS HN48-10- U 16x24.7x1.5 St/NBR	

SECTION 7 - HYDRAULIC INSTALL / INSTALLATION HYDRAULIQUE

FIGURE 7-6. VALVE ASSY, JIB CYLINDER / ASSEMBLAGE DISTRIBUTEUR VERIN BRAS

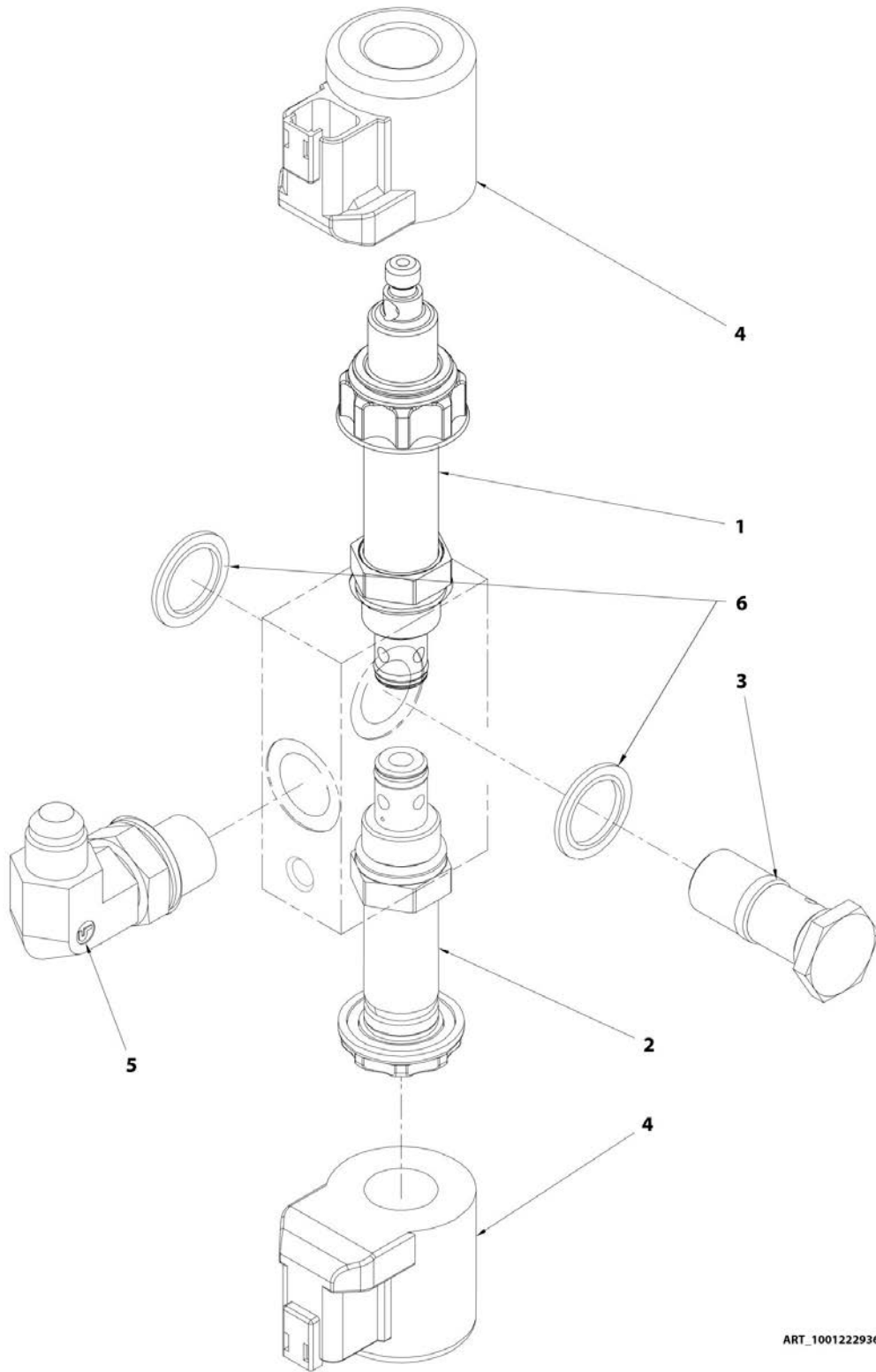

ART_1001222936

SECTION 7 - HYDRAULIC INSTALL / INSTALLATION HYDRAULIQUE

FIGURE 7-6. VALVE ASSY,JIB CYLINDER / ASSEMBLAGE DISTRIBUTEUR VERIN BRAS

ITEM	PART NUMBER	QTY	DESCRIPTION	REV
	1001222936	1	VALVE ASSY,JIB CYLINDER / ASSEMBLAGE DISTRIBUTEUR VERIN BRAS	A
1	1001225133	1	DIRECTIONAL VALVE 2/2 NC / VALVE DIRECTIONNELLE 2/2 NC	
2	1001225159	1	DIRECTIONAL VALVE 2/2 NC / VALVE DIRECTIONNELLE 2/2 NC	
3	1001225157	1	SCREW SRH G3/8 / VIS SRH G3/8	
4	952099	2	COIL, 24VDC_3012599 / BOBINE 24VDC_3012599	
5	300061	1	90° ELBOW MALE BSPP 3/8-MALE JIC 9/16 / COUDE 90° MALE BSPP3/8-MALE JIC9/16	
6	952107	2	BS RING_HN48-10-U 16x24.7x1.5 St/NBR / BAGUE BS HN48-10-U 16x24.7x1.5 St/NBR	

SECTION 8 - ELECTRICAL SYSTEM INSTALL / INSTALLATION ELECTRIQUE

**SECTION 8 - ELECTRICAL SYSTEM INSTALL / INSTALLATION
ELECTRIQUE**

SECTION 8 - ELECTRICAL SYSTEM INSTALL / INSTALLATION ELECTRIQUE

FIGURE 8-1. CABLES AND SWITCHES INSTALL DIAGRAM / DIAGRAMME D'INSTALLATION CABLES ET CAPTEURS

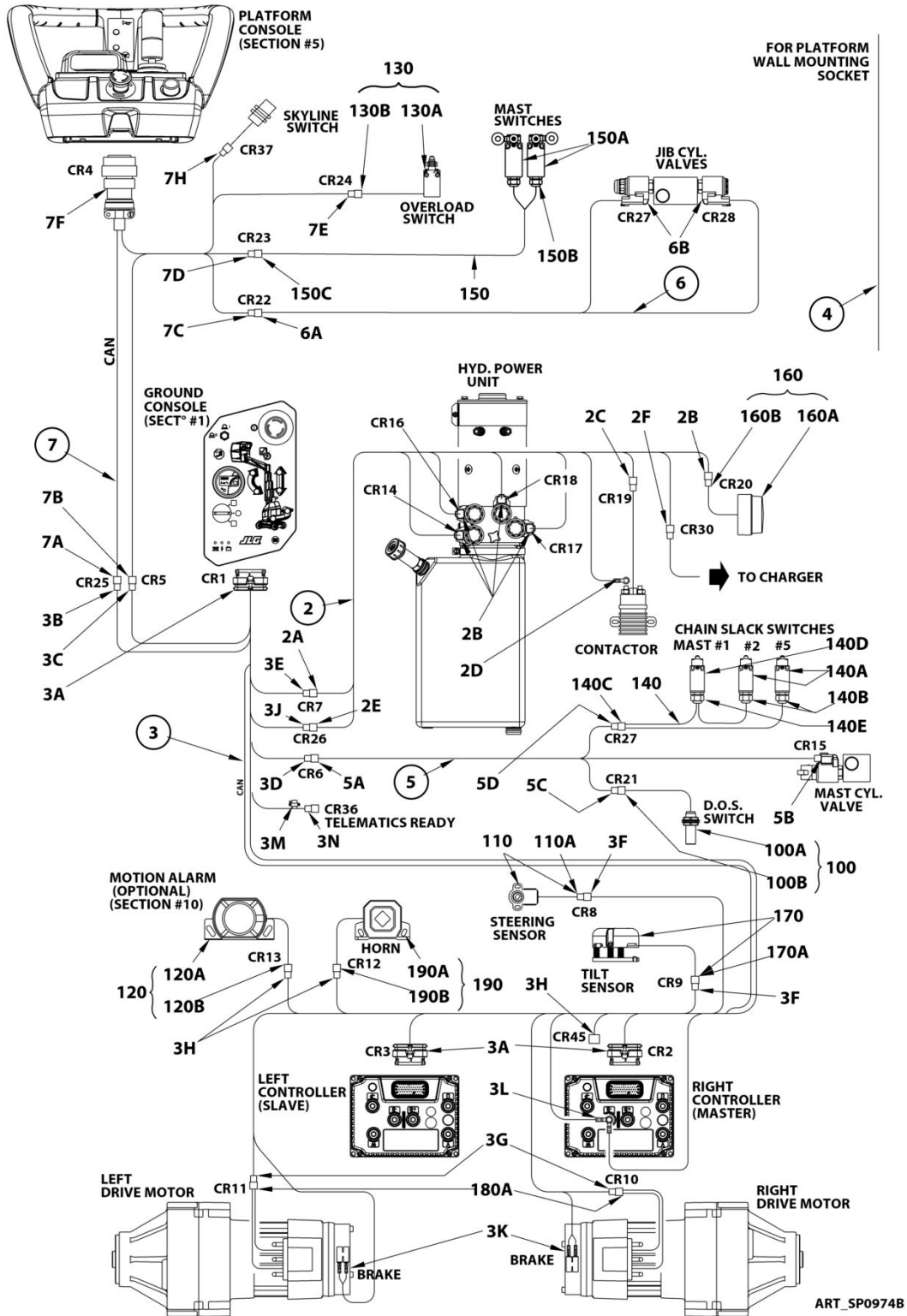

SECTION 8 - ELECTRICAL SYSTEM INSTALL / INSTALLATION ELECTRIQUE

**FIGURE 8-1. CABLES AND SWITCHES INSTALL DIAGRAM / DIAGRAMME D'INSTALLATION
CABLES ET CAPTEURS**

ITEM	PART NUMBER	QTY	DESCRIPTION	REV
	1001211413	Ref	INSTALL,CABLES / INSTALLATION CABLES	B
1	1001213899	1	KIT,POWER CABLES (SEE NEXT FIGURE) / KIT CABLES PUISSANCE (VOIR FIGURE SUIVANTE)	A
2	1001213970	1	HARNESS,HYDRAULIC UNIT / FAISCEAU CENTRALE HYDRAULIQUE	A
2A	4460931	1	CONNECTOR, DEUTSCH DT 8P RECEPTACLE / CONNECTEUR DEUTSCH DT 8P FEMELLE	
2A	4460464	8	CONTACT DEUTSCH DT PIN / CONTACT DEUTSCH DT MALE	
2B	4460891	5 x1	CONNECTOR, DEUTSCH DT 2P PLUG / CONNECTEUR DEUTSCH DT 2P MALE	
2B	4460465	5 x2	CONTACT DEUTSCH DT SOCKET / CONTACT DEUTSCH DT FEMELLE	
2C	4460897	1	CONNECTOR, DEUTSCH DT 2P RECEPTACLE / CONNECTEUR DEUTSCH DT 2P FEMELLE	
2C	4460464	2	CONTACT DEUTSCH DT PIN / CONTACT DEUTSCH DT MALE	
2D	250084	1	M8 EYELET TERMINAL 0.25-1mm ² / COSSE A OEIL ISOLEE M8 - 0.25-1mm ²	
2E	250026	1	RED RECEPTACLE TERM. 6.3 - 0.5-1.2mm ² / COSSE FEMELLE 6.3 ROUGE - 0.5-1.2mm ²	
2F	NOT SERVICEABLE	1	TERMINAL,INSULATE FASTON TAB 1/4- 0.5-1.2mm ² / COSSE MALE 1/4 ROUGE - 0.5-1.2mm ²	
3	1001213729	1	HARNESS,CHASSIS / FAISCEAU CHASSIS	D
3A	4460873	3 x1	CONNECTOR, HOUSING AMP 35P / CONNECTEUR AMP 35P	
3A	4460871	3 x35	CONTACT AMPSEAL, SOCKET / CONTACT AMPSEAL, FEMELLE	
3B	4460539	1	CONNECTOR, DEUTSCH DT 3P PLUG / CONNECTEUR DEUTSCH DT 3P MALE	
3B	4460944	3	TERMINAL,16-18 GA SOCKET (GOLD) / CONTACT DUTSCH DT FEMMELLE (OR)	
3C	4460933	1	CONNECTOR, DEUTSCH DT 12P PLUG / CONNECTEUR DEUTSCH DT 12P MALE	
3C	4460465	12	CONTACT DEUTSCH DT SOCKET / CONTACT DEUTSCH DT FEMELLE	
3D	4460894	1	CONNECTOR, DEUTSCH DT 6P PLUG / CONNECTEUR DEUTSCH DT 6P MALE	
3D	4460465	6	CONTACT DEUTSCH DT SOCKET / CONTACT DEUTSCH DT FEMELLE	
3E	4460930	1	CONNECTOR, DEUTSCH DT 8P PLUG / CONNECTEUR DEUTSCH DT 8P MALE	
3E	4460465	8	CONTACT DEUTSCH DT SOCKET / CONTACT DEUTSCH DT FEMELLE	
3F	4460539	2 x1	CONNECTOR, DEUTSCH DT 3P PLUG / CONNECTEUR DEUTSCH DT 3P MALE	
3F	4460465	2 x3	CONTACT DEUTSCH DT SOCKET / CONTACT DEUTSCH DT FEMELLE	
3G	250227	2 x1	CONNECTOR, DEUTSCH DTM 6P PLUG / CONNECTEUR DEUTSCH DTM 6P MALE	
3G	4460928	2 x6	CONTACT DEUTSCH DTM, SOCKET / CONTACT DEUTSCH DTM FEMELLE	
3H	4460891	3 x1	CONNECTOR, DEUTSCH DT 2P PLUG / CONNECTEUR	

SECTION 8 - ELECTRICAL SYSTEM INSTALL / INSTALLATION ELECTRIQUE

ITEM	PART NUMBER	QTY	DESCRIPTION	REV
3H	4460465	3 x2	DEUTSCH DT 2P MALE CONTACT DEUTSCH DT SOCKET / CONTACT DEUTSCH DT FEMELLE	
3J	NOT SERVICEABLE	1	TERMINAL,INSULATE FASTON TAB 1/4- 0.5-1.2mm ² / COSSE MALE 1/4 ROUGE - 0.5-1.2mm ²	
3K	250060	4	RECEPTACLE TERMINAL 4.8 - 0.25-1mm ² / COSSE ISOLEE 4.8 mm 0.25-1 mm ²	
3L	250091	2	M6 EYELET TERMINAL 1-2.5mm ² / COSSE A OEIL ISOLEE M6 - 1-2.5mm ²	
3M	2400060	1	FUSE,HOLDER W/COVER / PORTE FUSIBLE	
3M	8229242	1	FUSE,5 A MINI / FUSIBLE 5A	
3N	4460884	1	PLUG,4-PIN CONNECTOR / CONNECTEUR 4 BROCHES	
3N	4460465	4	CONTACT DEUTSCH DT SOCKET / CONTACT DEUTSCH DT FEMELLE	
3N	1001192401	1	CONNECTOR,DUST CAP / PROTECTION CONNECTEUR	
4	270059	12 m	CABLE 3G2.5mm² Color leads (qty in meters) / CABLE 3G2.5mm² coloré (qté en mètre)	
5	PC0488	1	HARNESS, TURNTABLE / FAISCEAU MAT 1	A
5A	4460899	1	CONNECTOR, DEUTSCH DT 6P RECEPTACLE / CONNECTEUR DEUTSCH DT 6P FEMELLE	
5A	4460464	5	CONTACT DEUTSCH DT PIN / CONTACT DEUTSCH DT MALE	
5B	4460891	1	CONNECTOR, DEUTSCH DT 2P PLUG / CONNECTEUR DEUTSCH DT 2P MALE	
5B	4460465	2	CONTACT DEUTSCH DT SOCKET / CONTACT DEUTSCH DT FEMELLE	
5C	4461077	1	CONNECTOR, DEUTSCH DTM 4P PLUG / CONNECTEUR DEUTSCH DTM 4P MALE	
5C	4460928	3	CONTACT DEUTSCH DTM, SOCKET / CONTACT DEUTSCH DTM FEMELLE	
5D	4460932	1	CONNECTOR, DEUTSCH DT 4P RECEPTACLE / CONNECTEUR DEUTSCH DT 4P FEMELLE	
5D	4460464	4	CONTACT DEUTSCH DT PIN / CONTACT DEUTSCH DT MALE	
6	PC0489	1	HARNESS, JIB VALVES / FAISCEAU ELECTROVANNE BRAS	C
6A	4460536	1	CONNECTOR, DEUTSCH DT 3P RECEPTACLE / CONNECTEUR DEUTSCH DT 3P FEMELLE	
6A	4460464	3	CONTACT DEUTSCH DT PIN / CONTACT DEUTSCH DT MALE	
6B	4460891	2 x1	CONNECTOR, DEUTSCH DT 2P PLUG / CONNECTEUR DEUTSCH DT 2P MALE	
6B	4460465	2 x2	CONTACT DEUTSCH DT SOCKET / CONTACT DEUTSCH DT FEMELLE	
7	1001267235	1	HARNESS,UCB / FAISCEAU BOITIER HAUT	B
7A	4460536	1	CONNECTOR, DEUTSCH DT 3P RECEPTACLE / CONNECTEUR DEUTSCH DT 3P FEMELLE	
7A	4460943	3	TERMINAL,16-18 GA PIN (GOLD) / CONTACT DEUTSCH DT MALE (OR)	
7B	4460970	1	CONNECTOR, DEUTSCH DT 12P RECEPTACLE / CONNECTEUR DEUTSCH DT 12P FEMELLE	
7B	4460464	12	CONTACT DEUTSCH DT PIN / CONTACT DEUTSCH DT MALE	
7C	4460539	1	CONNECTOR, DEUTSCH DT 3P PLUG / CONNECTEUR DEUTSCH DT 3P MALE	
7C	4460465	3	CONTACT DEUTSCH DT SOCKET / CONTACT DEUTSCH DT FEMELLE	

SECTION 8 - ELECTRICAL SYSTEM INSTALL / INSTALLATION ELECTRIQUE

ITEM	PART NUMBER	QTY	DESCRIPTION	REV
7D	4460899	1	CONNECTOR, DEUTSCH DT 6P RECEPTACLE / CONNECTEUR DEUTSCH DT 6P FEMELLE	
7D	4460464	6	CONTACT DEUTSCH DT PIN / CONTACT DEUTSCH DT MALE	
7E	4460932	1	CONNECTOR, DEUTSCH DT 4P RECEPTACLE / CONNECTEUR DEUTSCH DT 4P FEMELLE	
7E	4460464	4	CONTACT DEUTSCH DT PIN / CONTACT DEUTSCH DT MALE	
7F	1001267665	1	CONNECTOR, DEUTCH HDP 20P / CONNECTEUR DEUTSCH HDP 20P MALE	
7F	1001116694	13	CONTACT DEUTSCH DTM SOCKET / CONTACT DEUTSCH DTM FEMELLE	
7F	1001116692	2	CONTACT DEUTSCH DT SOCKET / CONTACT DEUTSCH DT FEMELLE	
7F	1001119619	2	CONTACT DEUTSCH DTM SOCKET (GOLD) / CONTACT DEUTSCH DTM FEMELLE (OR)	
7H	4461077	1	CONNECTOR, DEUTSCH DTM 4P PLUG / CONNECTEUR DEUTSCH DTM 4P MALE	
7H	1001126009	4	CONTACT DEUTSCH DTM, SOCKET (GOLD) / CONTACT DEUTSCH DTM FEMELLE (OR)	
100	4000008	1	PROXIMITY SENSOR ASSEMBLY / FAISCEAU DETECTEUR DE PROXIMITE	B
100A	4000007	1	SENSOR, PROXIMITY / DETECTEUR DE PROXIMITE	
100B	4461076	1	CONNECTOR, DEUTSCH DTM 4P RECEPTACLE / CONNECTEUR DEUTSCH DTM 4P FEMELLE	
100B	4460917	4	CONTACT DEUTSCH DTM, GOLD PIN / CONTACT DEUTSCH DTM MALE DORE	
110	4360505	1	ROTARY ANGLE SENSOR / CAPTEUR D'ANGLE	C
110A	4460536	1	CONNECTOR, DEUTSCH DT 3P RECEPTACLE / CONNECTEUR DEUTSCH DT 3P FEMELLE	
110A	4460464	3	CONTACT DEUTSCH DT PIN / CONTACT DEUTSCH DT MALE	
120	PC0466	1	HARNESS, MOTION ALARM / FAISCEAU ALARME DE MOUVEMENT	A
120A	260275	1	ACCOUSTIC MOTION ALARM / ALARME DE MOUVEMENT SONORE	
120B	4460897	1	CONNECTOR, DEUTSCH DT 2P RECEPTACLE / CONNECTEUR DEUTSCH DT 2P FEMELLE	
120B	4460464	2	CONTACT DEUTSCH DT PIN / CONTACT DEUTSCH DT MALE	
130	PC0468	1	HARNESS, LOAD SENSING SWITCH / FAISCEAU CAPTEUR DE SURCHARGE	B
130A	260321	1	LIMIT SWITCH, SNAP ACTION / DETECTEUR DE POSITION A POUSSOIR	
130B	4460884	1	CONNECTOR, DEUTSCH DT 4P PLUG / CONNECTEUR DEUTSCH DT 4P MALE	
130B	4460465	4	CONTACT DEUTSCH DT SOCKET / CONTACT DEUTSCH DT FEMELLE	
140	PC0469	1	HARNESS, CHAIN SLACK SWITCHES / FAISCEAU CAPTEURS MOU DE CHAINE	C
140A	260327	2	SWITCH NO NC PG11 / CAPTEUR NO NF PG11	
140B	210018	2	GLAND N°11 / PRESSE ETOUPE N°11	
140C	4460884	1	CONNECTOR, DEUTSCH DT 4P PLUG / CONNECTEUR DEUTSCH DT 4P MALE	
140C	4460465	4	CONTACT DEUTSCH DT SOCKET / CONTACT DEUTSCH DT	

SECTION 8 - ELECTRICAL SYSTEM INSTALL / INSTALLATION ELECTRIQUE

ITEM	PART NUMBER	QTY	DESCRIPTION	REV
140D	260326	1	FEMELLE NO/NC SWITCH PG13 / CAPTEUR NO NF PG13	
140E	210059	1	GLAND N°13 2xØ5 IP65 / PRESSE ETOUPE N°13 2xØ5 IP65	
150	PC0470	1	HARNESS, MAST LIMIT SWITCHES / FAISCEAU CAPTEUR DE MAT	B
150A	260323	2	NO/NC SWITCH / CAPTEUR NO/NF	
150B	210018	2	GLAND N°11 / PRESSE ETOUPE N°11	
150C	4460894	1	CONNECTOR, DEUTSCH DT 6P PLUG / CONNECTEUR DEUTSCH DT 6P MALE	
150C	4460465	6	CONTACT DEUTSCH DT SOCKET / CONTACT DEUTSCH DT FEMELLE	
160	PC0534	1	HARNESS, BEACON / FAISCEAU FEU A ECLATS	A
160A	260329	1	FLASHING LIGHT / FEU A ECLATS	
160B	4460897	1	CONNECTOR, DEUTSCH DT 2P RECEPTACLE / CONNECTEUR DEUTSCH DT 2P FEMELLE	
160B	4460464	2	CONTACT DEUTSCH DT PIN / CONTACT DEUTSCH DT MALE	
170	1001213835	1	SENSOR,TILT 2.4° / DETECTEUR DE DEVERS 2.4°	A
170A	4460536	1	CONNECTOR, DEUTSCH DT 3P RECEPTACLE / CONNECTEUR DEUTSCH DT 3P FEMELLE	
170A	4460464	3	CONTACT DEUTSCH DT PIN / CONTACT DEUTSCH DT MALE	
180	1001245202	1	DRIVE GEAR MOTOR / MOTOREDUCTEUR DE ROUE	B
180A	250230	2 x1	CONNECTOR, DEUTSCH DTM 6P HOUSING / CONNECTEUR DEUTSCH DTM 6P FEMELLE	
180A	4460917	2 x6	CONTACT DEUTSCH DTM, GOLD PIN / CONTACT DEUTSCH DTM MALE DORE	
190	PC0491	1	HARNESS, HORN / FAISCEAU AVERTISSEUR SONORE	A
190A	260274	1	HORN / KLAXON	
190B	4460897	1	CONNECTOR, DEUTSCH DT 2P RECEPTACLE / CONNECTEUR DEUTSCH DT 2P FEMELLE	
190B	4460464	2	CONTACT DEUTSCH DT PIN / CONTACT DEUTSCH DT MALE	

SECTION 8 - ELECTRICAL SYSTEM INSTALL / INSTALLATION ELECTRIQUE

FIGURE 8-2. KIT, POWER CABLES / KIT CABLES DE PUISSANCE

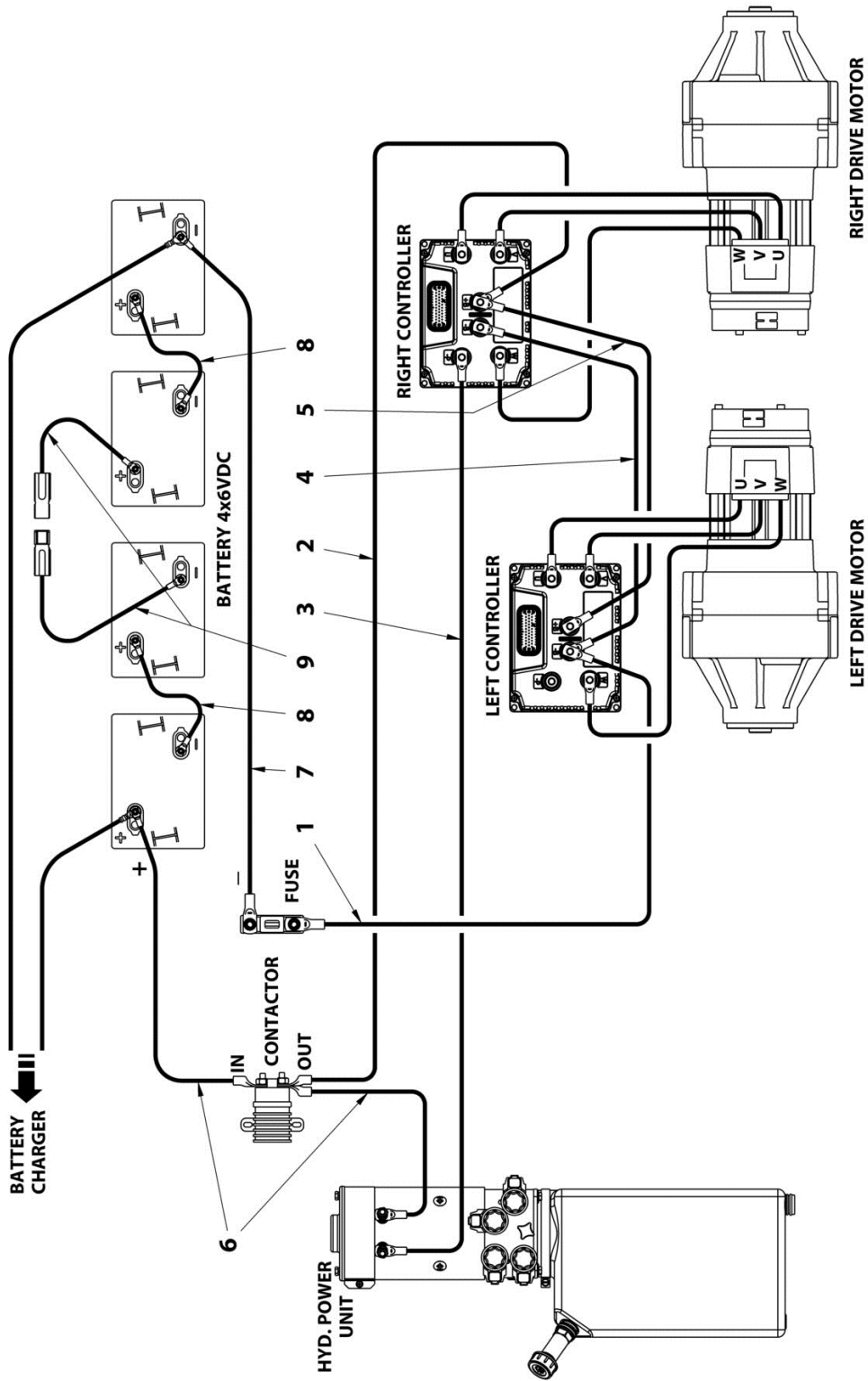

ART_1001211413

SECTION 8 - ELECTRICAL SYSTEM INSTALL / INSTALLATION ELECTRIQUE

FIGURE 8-2. KIT,POWER CABLES / KIT CABLES DE PUISSANCE

ITEM	PART NUMBER	QTY	DESCRIPTION	REV
	1001213899	Ref	KIT,POWER CABLES / DIAGRAMME D'INSTALLATION CABLES	A
1	PC0479	1	CABLE 35mm ² LENGHT 3950mm BLUE / CABLE 35mm ² L=3950mm BLEU	
2	PC0480	1	CABLE 35mm ² LENGHT 3950mm RED / CABLE 35mm ² L=3950mm ROUGE	
3	PC0482	1	CABLE 35mm ² LENGHT 3950mm BLACK / CABLE 35mm ² L=3950mm NOIR	
4	PC0483	1	CABLE 35mm ² LENGHT 550mm BLUE / CABLE 35mm ² L=550mm BLEU	
5	PC0484	1	CABLE 35mm ² LENGHT 550mm RED / CABLE 35mm ² L=550mm ROUGE	
6	1001213902	2	CABLE 35mm ² L=280mm RED / CABLE 35mm ² L=280mm ROUGE	
7	1001213903	1	CABLE 35mm ² L=410mm BLUE / CABLE 35mm ² L=410mm BLEU	
8	1001213904	2	CABLE 35mm ² L=560mm BLACK / CABLE 35mm ² L=560mm NOIR	
9	1001213905	2	CABLE 35mm ² LENGTH 630mm BLACK - QUICK CONNECTOR / CABLE 35mm ² LONG 630mm NOIR - CONNECTEUR RAPIDE	

SECTION 8 - ELECTRICAL SYSTEM INSTALL / INSTALLATION ELECTRIQUE

FIGURE 8-3. BATTERY AND CHARGER INSTALL / INSTALLATION BATTERIES ET CHARGEUR

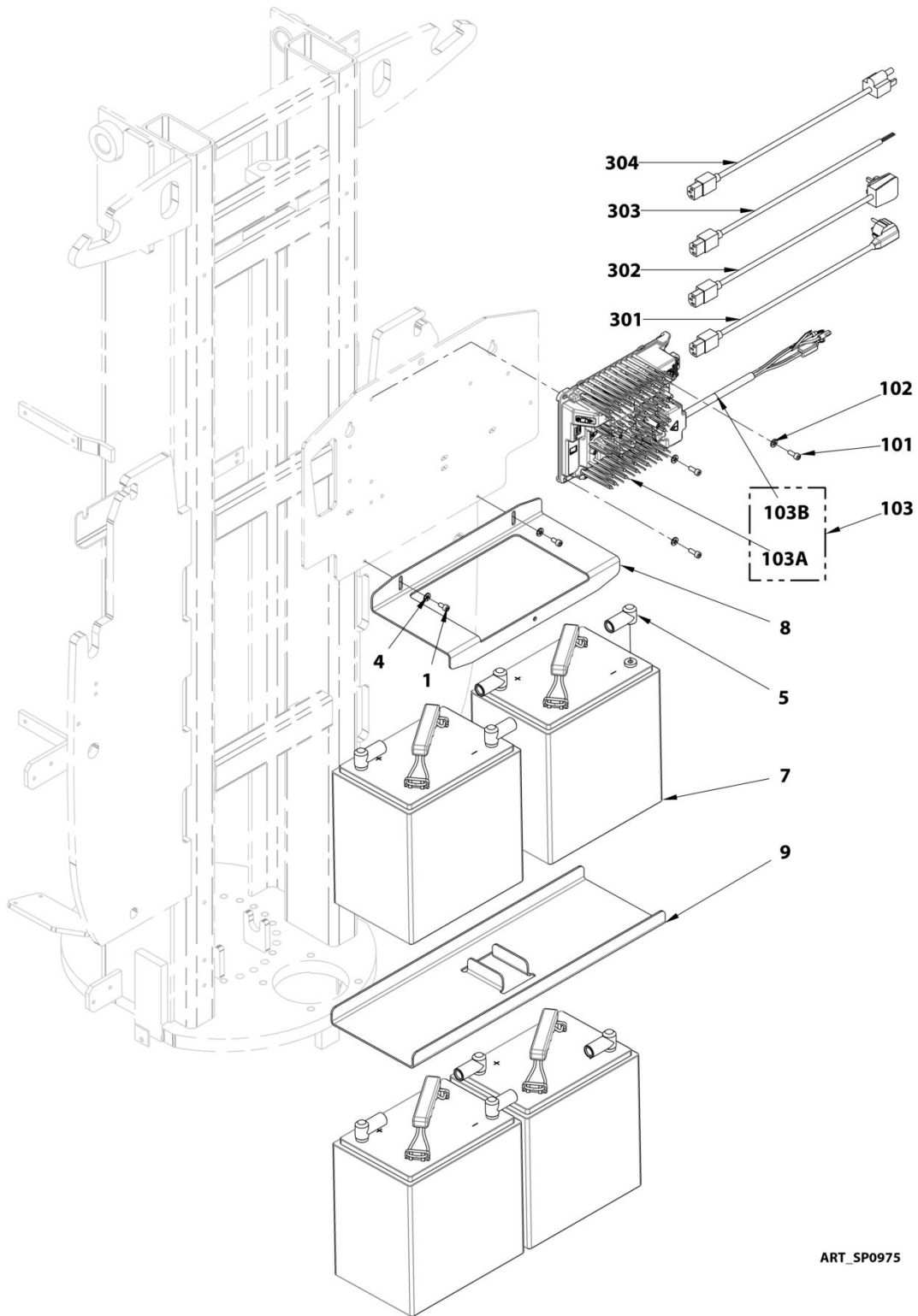

ART_SP0975

SECTION 8 - ELECTRICAL SYSTEM INSTALL / INSTALLATION ELECTRIQUE

FIGURE 8-3. BATTERY AND CHARGER INSTALL / INSTALLATION BATTERIES ET CHARGEUR

ITEM	PART NUMBER	QTY	DESCRIPTION	REV
	1001211415	Ref	INSTALL,BATTERIES / INSTALLATION BATTERIES	B
1	000014	2	M06x12 8.8 SOCKET HEAD MACH SCREW / VIS CHC M06x12 8.8 BI FT	
4	120009	2	LOCK WASHER D06x14 / RONDELLE CONTACT dD 06x14 BI	
5	250031	8	BOOT,BATTERY TERMINAL / CAPUCHON D'ETANCHEITE	
7	510094	4	BATTERY,AGM EVGT 6A-A / BATTERIE AGM EVGT 6A-A	
8	ST3776	1	PLATE,BATTERY STOP / BRIDE DE BATTERIES	
9	ST3778	1	CONTAINER,BATTERY / BAC DE RETENTION BATTERIE	
	1001211414	Ref	INSTALL,CHARGER / INSTALLATION CHARGEUR	B
101	000015	3	M06x16 8.8 SOCKET HEAD MACH SCREW / VIS CHC M06x16 8.8 BI FT	
102	120009	3	LOCK WASHER D06x14 / RONDELLE CONTACT dD 06x14 BI	
103	1001213986	1	CHARGER,WITH HARNESS / CHARGEUR AVEC FAISCEAU	
103A	1001213033	1	CHARGER W/O HARNESS / CHARGEUR SANS FAISCEAU	
103B	1001213985	1	HARNESS,CHARGER / FAISCEAU CHARGEUR	
		Ref	CHARGEUR EXTENSION / PRISE CHARGEUR	
301	250211	1	CABLE IEC22 / PLUG CEE7 2m 10A / CORDON IEC22 / FICHE CEE7 2m 10A	
302	250213	1	CABLE IEC22 / PLUG BS1362 2m 10A / CORDON IEC22 / FICHE BS1362 2m 10A	
303	1060689	1	CABLE AC CORD, W/O PLUG, L=2m / CABLE CA CHARGEUR, SANS PRISE, L=2m	
304	1060688	1	CABLE AC CORD, US PLUG, L=2m / CABLE AC CHARGEUR, US, L=2m	

SECTION 8 - ELECTRICAL SYSTEM INSTALL / INSTALLATION ELECTRIQUE

FIGURE 8-4. SWITCHES AND COVERS INSTALL / INSTALLATION CAPTEURS

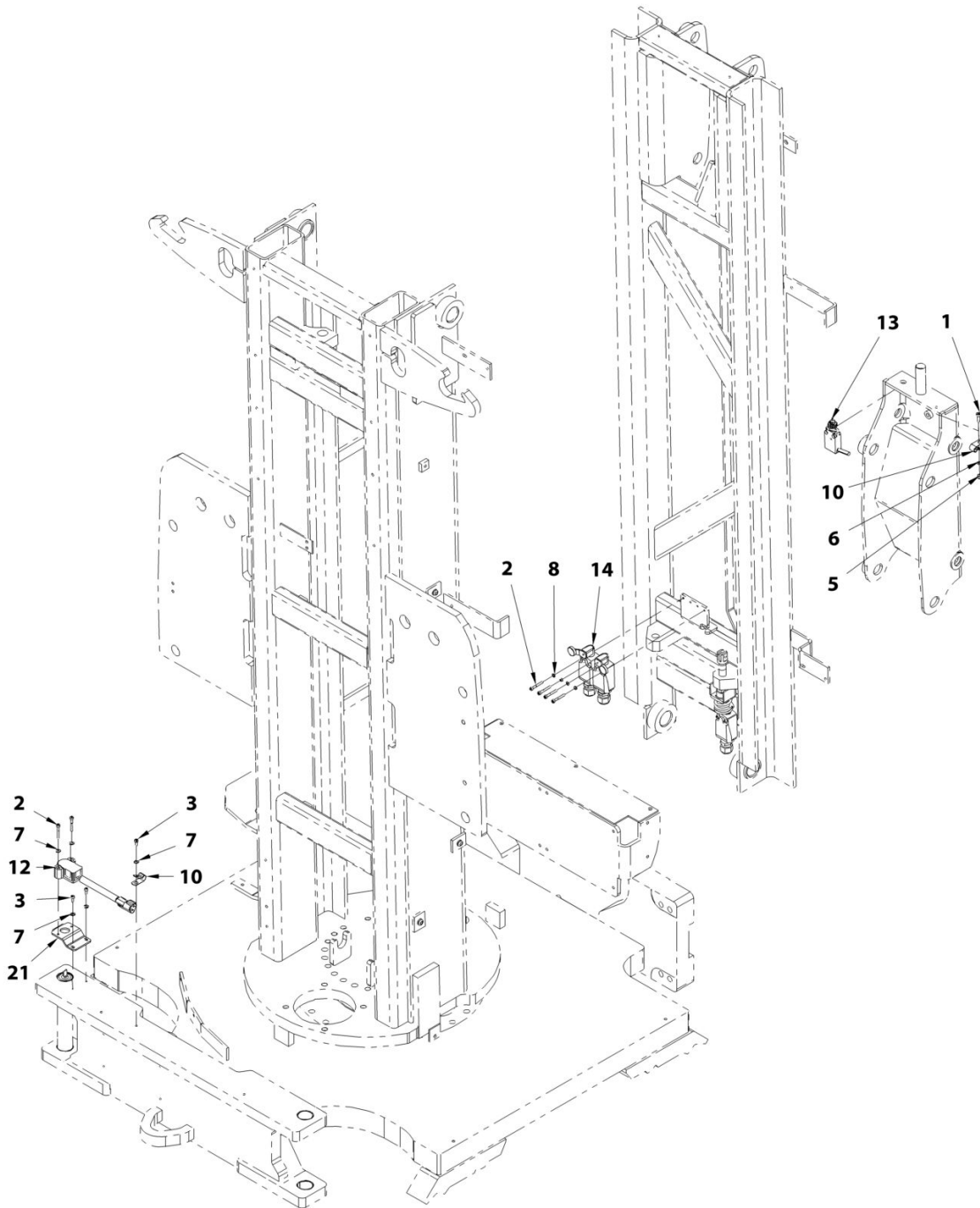

ART_SA0012

SECTION 8 - ELECTRICAL SYSTEM INSTALL / INSTALLATION ELECTRIQUE

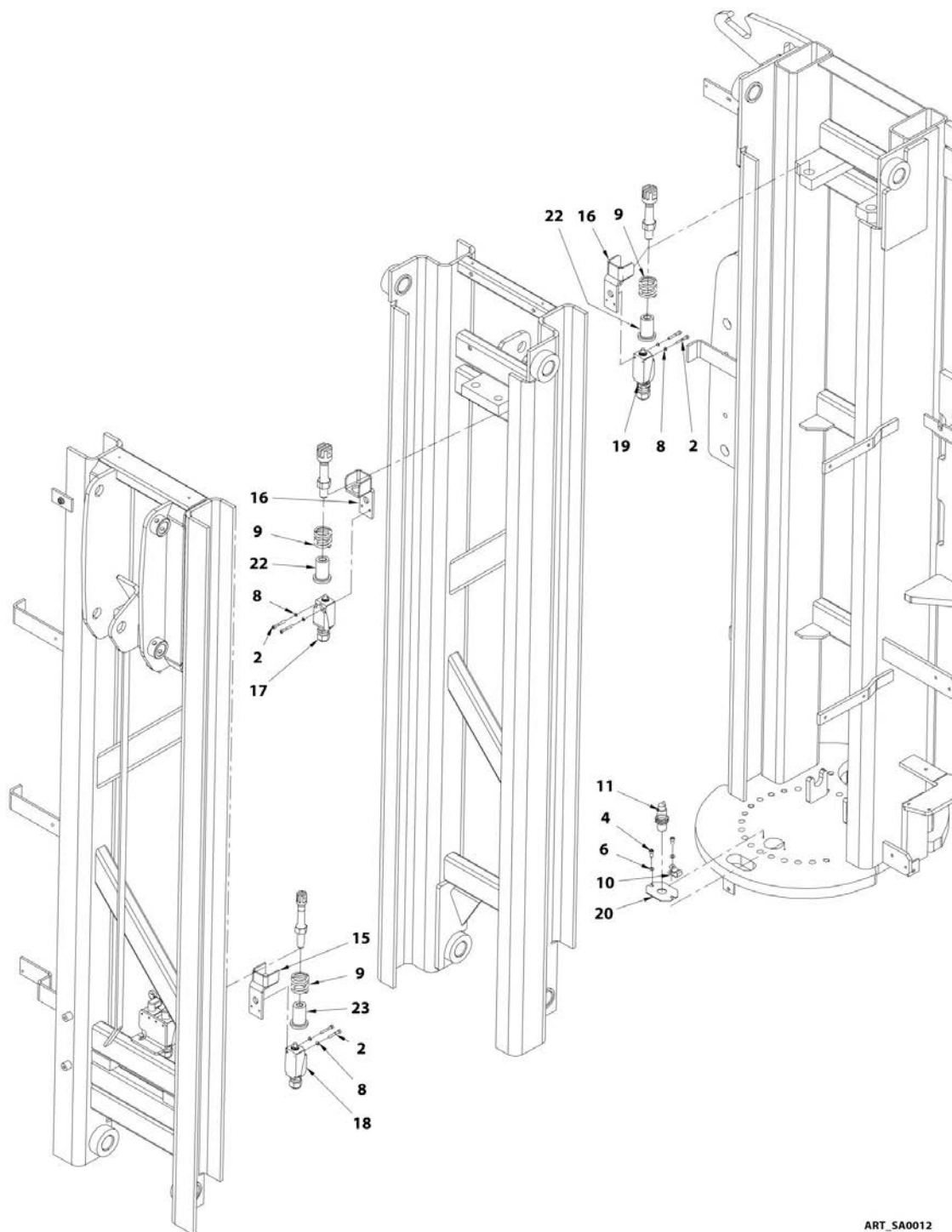

ART_SA0012

SECTION 8 - ELECTRICAL SYSTEM INSTALL / INSTALLATION ELECTRIQUE

FIGURE 8-4. SWITCHES AND COVERS INSTALL / INSTALLATION CAPTEURS

ITEM	PART NUMBER	QTY	DESCRIPTION	REV
	SA0012		SWITCHES AND COVERS INSTALL / INSTALLATION CAPTEURS	A
1	000003	1	M05x16 8.8 SOCKET HEAD MACH SCREW / VIS CHC M05x16 8.8 BI FT	
2	000007	12	M04x30 8.8 SOCKET HEAD CAPSCREW / VIS CHC M04x30 8.8 BI FP	
3	000050	3	M04x10 8.8 SOCKET HEAD MACH SCREW / VIS CHC M04x10 8.8 BI FT	
4	000067	2	M05x12 8.8 SOCKET HEAD MACH SCREW / VIS CHC M05x12 8.8 BI FT	
5	110002	1	M05 GR08 LOCK NUT / ECROU FREIN M5 CL08 BI	
6	120002	3	M05 WASHER / RONDELLE M05 BI	
7	120024	5	M04 LOCK WASHER / RONDELLE CONTACT M04 BI	
8	120056	10	dD 04x08 LOCK WASHER / RONDELLE CONTACT dD 04x08 BI	
9	160010	3	C 360 450 320 SPRING / RESSORT C 360 450 320	
10	1321293	3	INSULATED BAND / COLLIER ISOLE	
11	4000008	1	PROXIMITY SENSOR ASSEMBLY / FAISCEAU DETECTEUR DE PROXIMITE	
12	4360505	1	SWITCH,ROTARY ANGLE SENSOR / CAPTEUR D'ANGLE	
13	PC0468	1	HARNESS,LOAD SENSING SWITCH / FAISCEAU CAPTEUR DE SURCHARGE	
14	PC0470	1	HARNESS,T10E MAST LIMIT SWITCHES / T10E - FAISCEAU CAPTEURS DE MAT	
15	SD0345	1	SWITCH HOLDER / SUPPORT CAPTEUR	
16	SD0464	2	SWITCH HOLDER / SUPPORT CAPTEUR	
17	SE1139	1	HARNESS,CHAIN SLACK MAST 2; INFO - PC0469 / FAISCEAU CAPTEUR MOU DE CHAINE MAT 2; INFO - PC0469	
18	SE1140	1	HARNESS,CHAIN SLACK MAST 5; INFO - PC0469 / FAISCEAU CAPTEUR MOU DE CHAINE MAT 5; INFO - PC0469	
19	SE1141	1	HARNESS,CHAIN SLACK MAST 1; INFO - PC0469 / FAISCEAU CAPTEUR MOU DE CHAINE MAT 1; INFO - PC0469	
20	ST3226	1	D.O.S. SWITCH MOUNT / PLATINE CAPTEUR D'ORIENTATION	
21	ST3227	1	ROTARY SWITCH MOUNT / PLATINE CAPTEUR ROTATIF	
22	US0204	2	ACTUATOR M16 / ACTIONNEUR M16	
23	US0208	1	ACTUATOR M14 / ACTIONNEUR M14	

SECTION 9 - DECALS INSTALL / INSTALLATION AUTOCOLLANTS

SECTION 9 - DECALS INSTALL / INSTALLATION AUTOCOLLANTS

SECTION 9 - DECALS INSTALL / INSTALLATION AUTOCOLLANTS

FIGURE 9-1. DECALS ALL PRODUCTS / INSTALLATION TOUT PRODUIT

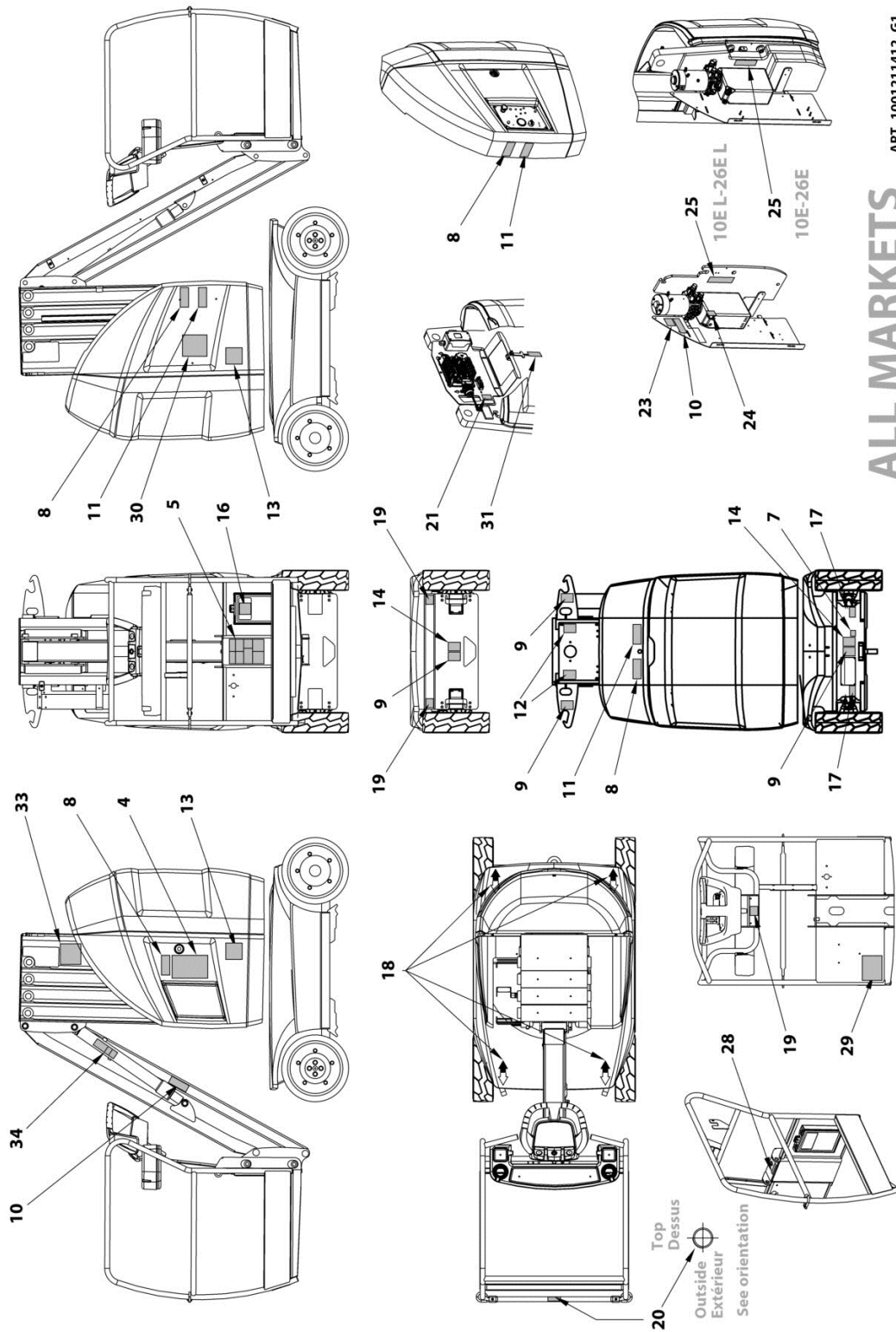

ALL MARKETS

ART_1001211412_G1

SECTION 9 - DECALS INSTALL / INSTALLATION AUTOCOLLANTS

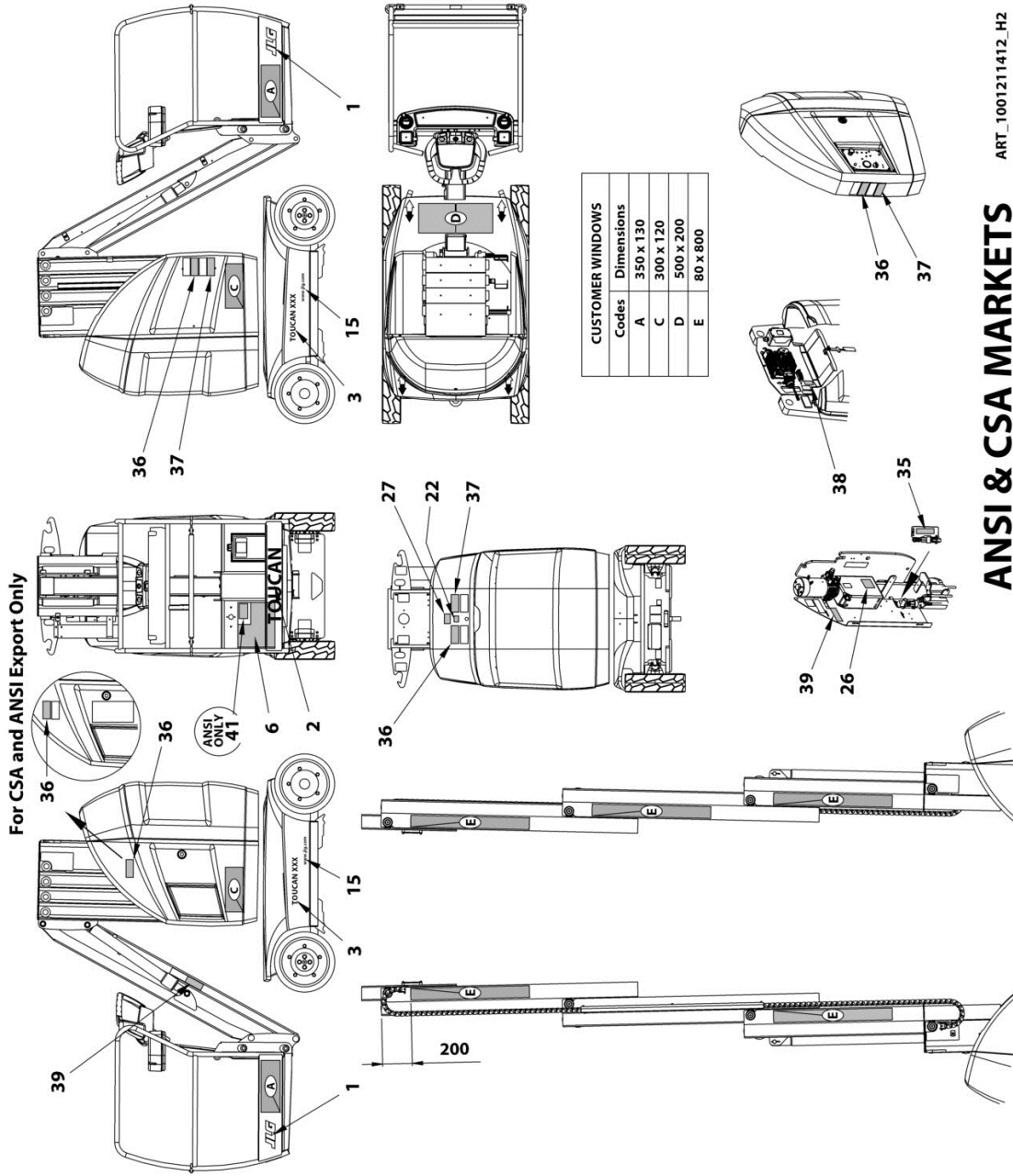

ANSI & CSA MARKETS

ART_1001211412_H2

SECTION 9 - DECALS INSTALL / INSTALLATION AUTOCOLLANTS

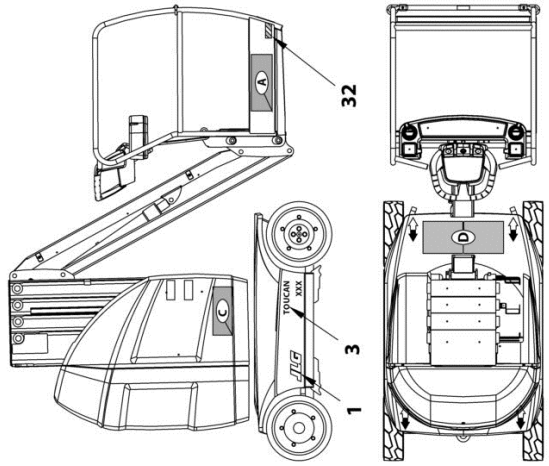

CUSTOMER WINDOWS	
Codes	Dimensions
A	350 x 130
B	400 x 80
C	300 x 120
D	500 x 200
E	80 x 800

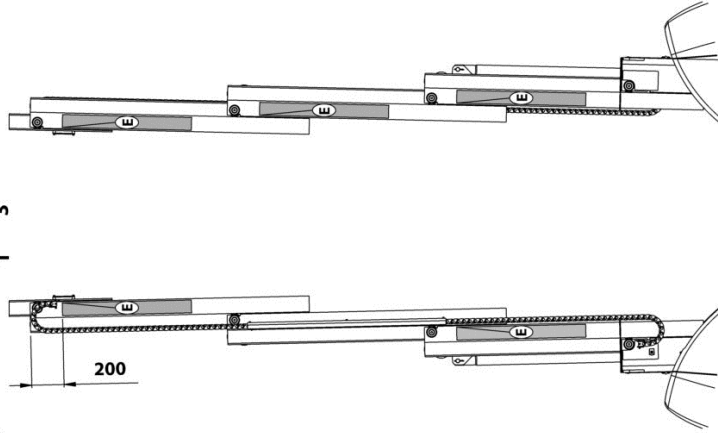
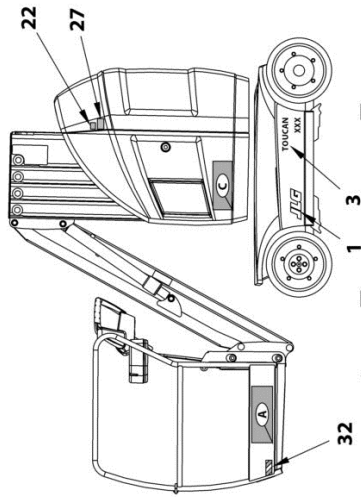
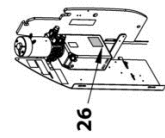
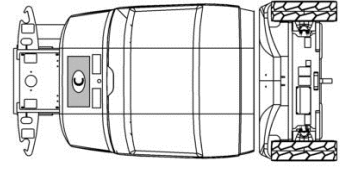
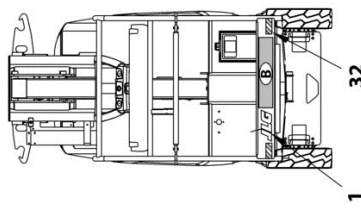

ART_1001211412_H3

CE MARKET

SECTION 9 - DECALS INSTALL / INSTALLATION AUTOCOLLANTS

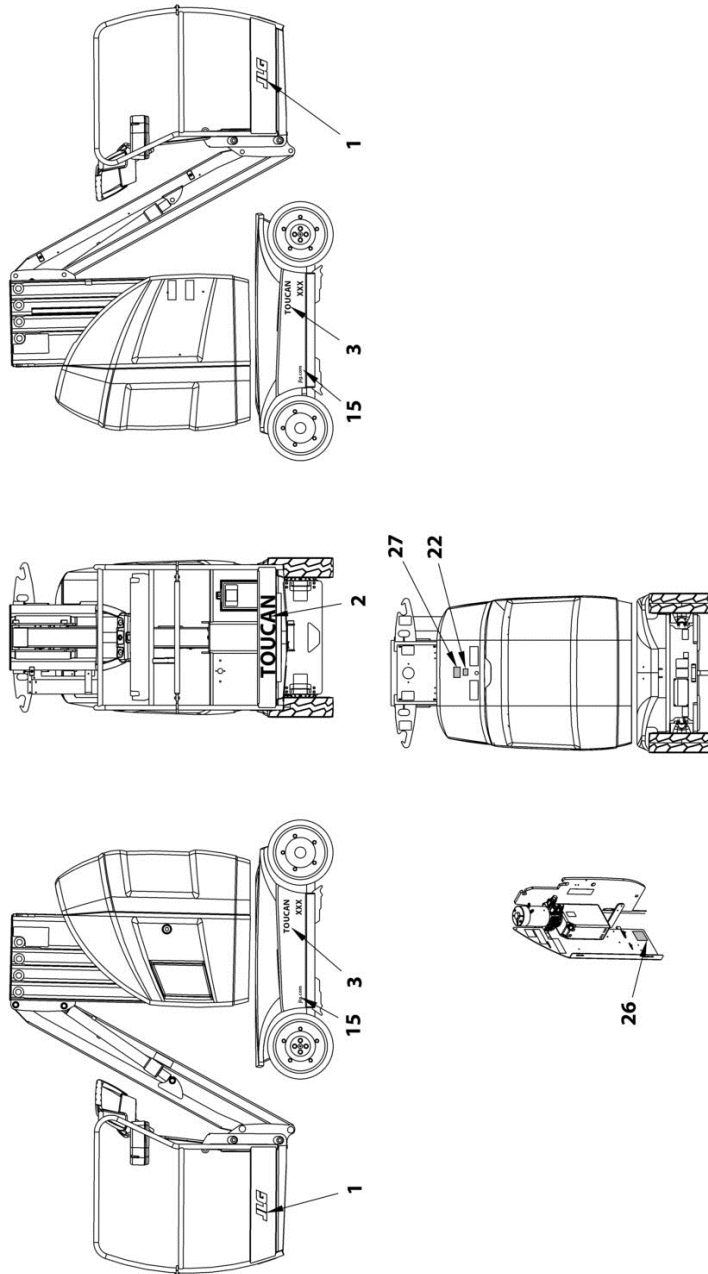

AS & NZL MARKETS

ART_1001211412_H4

SECTION 9 - DECALS INSTALL / INSTALLATION AUTOCOLLANTS

FIGURE 9-1. DECALS INSTALL / INSTALLATION AUTOCOLLANTS

ITEM	PART NUMBER	QTY	DESCRIPTION	REV
	1001211412		DECALS INSTALL / INSTALLATION AUTOCOLLANTS	I
	PA1138	Ref	INSTALL,DECAL JLG LOGOS / INSTALLATION LOGOS JLG	A
1	1705781	3	DECAL, JLG 2.75" / AUTOCOLLANT, JLG	
2	AU1825	1	DECAL, FRONT BASKET TOUCAN / AUTOCOLLANT, LOGO TOUCAN AVANT PANIER	
3	1001267748	1	DECAL,MODEL DESIGNATION 10E / AUTOCOLLANT, LOGO TOUCAN 10E	
3	1001267749	1	DECAL,MODEL DESIGNATION 10E-L / AUTOCOLLANT, LOGO TOUCAN 10E-L	
3	1001267750	1	DECAL,MODEL DESIGNATION 26E / AUTOCOLLANT, LOGO TOUCAN 26E	
3	1001267751	1	DECAL,MODEL DESIGNATION 26E-L / AUTOCOLLANT, LOGO TOUCAN 26E-L	
	1001211418	Ref	10E - DECALS LOADS / 10E - AUTOCOLLANTS CHARGES	B
4	AU2109	1	10E - DECAL,INSTRUCTIONS AND LOADS / 10E - AUTOCOLLANT, CHARGES ET CONSIGNES	
5	AU2102	1	10E - DECAL,LOADS AND INSTRUCTION / 10E - AUTOCOLLANT, CHARGES ET CONSIGNES	
7	1001214286	1	10E - DECAL,WHEEL LOAD / 10E - AUTOCOLLANT, CHARGE SUR ROUE	
	1001211419	Ref	10E-L - DECALS LOADS / 10E-L - AUTOCOLLANTS CHARGES	B
4	1001214285	1	10E-L - DECAL,INSTRUCTIONS AND LOADS / 10E-L - AUTOCOLLANT, CHARGES ET CONSIGNES	
5	1001214284	1	10E-L - DECAL,LOADS AND INSTRUCTION / 10E-L - AUTOCOLLANT, CHARGES ET CONSIGNES	
7	1001214287	1	10E-L - DECAL,WHEEL LOAD / 10E-L - AUTOCOLLANT, CHARGE SUR ROUE	
	1001228973	Ref	10E (L) - DECALS LOADS RUSSIA (EAC) / 10E (L) - AUTOCOLLANTS CHARGES RUSSE (EAC)	A
4	1001228601	1	10E (L) - DECAL,LOADS AND INSTRUCTION / 10E (L) - AUTOCOLLANT, CHARGES ET CONSIGNES	
5	1001228600	1	10E (L) - DECAL,LOADS AND INSTRUCTION / 10E (L) - AUTOCOLLANT, CHARGES ET CONSIGNES	
7	1001214286	1	10E (L) - DECAL,WHEEL LOAD / 10E (L) - AUTOCOLLANT, CHARGE SUR ROUE	
	1001223681	Ref	26E - (ENG) DECALS LOADS / 26E - (ENG) AUTOCOLLANTS CHARGES	A
4	1001223845	1	26E - (ENG) DECAL,LOADS AND INSTRUCTION / 26E - (ENG) AUTOCOLLANT, CHARGES ET CONSIGNES	
5	1001223853	1	26E - (ENG) DECAL,LOADS AND INSTRUCTION / 26E - (ENG) AUTOCOLLANT, CHARGES ET CONSIGNES	
7	1001223863	1	26E - DECAL,WHEEL LOAD / 26E - AUTOCOLLANT, CHARGE SUR ROUE	
	1001223682	Ref	26E-L - (ENG) DECALS LOADS / 26E-L - (ENG) AUTOCOLLANTS CHARGES	A
4	1001223846	1	26E-L - (ENG) DECAL,LOADS AND INSTRUCTION / 26E-L - (ENG) AUTOCOLLANT, CHARGES ET CONSIGNES	
5	1001223854	1	26E-L - (ENG) DECAL,LOADS AND INSTRUCTION / 26E-L -	

SECTION 9 - DECALS INSTALL / INSTALLATION AUTOCOLLANTS

ITEM	PART NUMBER	QTY	DESCRIPTION	REV
7	1001223864	1	(ENG) AUTOCOLLANT, CHARGES ET CONSIGNES 26E-L - DECAL,WHEEL LOAD / 26E-L - AUTOCOLLANT, CHARGE SUR ROUE	
	1001223683	Ref	26E - (SPA-POR) DECALS LOADS / 26E - (SPA-POR) AUTOCOLLANTS CHARGES	A
4	1001223847	1	26E - (SPA-POR) DECAL,LOADS AND INSTRUCTION / 26E - (SPA-POR) AUTOCOLLANT, CHARGES ET CONSIGNES	
5	1001223855	1	26E - (SPA) DECAL,LOADS AND INSTRUCTION / 26E - (SPA) AUTOCOLLANT, CHARGES ET CONSIGNES	
6	1001223933	1	26E - (POR) DECAL,LOADS AND INSTRUCTION / 26E - (POR) AUTOCOLLANT, CHARGES ET CONSIGNES	
7	1001223863	1	26E - DECAL,WHEEL LOAD / 26E - AUTOCOLLANT, CHARGE SUR ROUE	
	1001223684	Ref	26E-L - (SPA-POR) DECALS LOADS / 26E-L - (SPA-POR) AUTOCOLLANTS CHARGES	A
4	1001223848	1	26E-L - (SPA-POR) DECAL,LOADS AND INSTRUCTION / 26E-L - (SPA-POR) AUTOCOLLANT, CHARGES ET CONSIGNES	
5	1001223856	1	26E-L - (SPA) DECAL,LOADS AND INSTRUCTION / 26E-L - (SPA) AUTOCOLLANT, CHARGES ET CONSIGNES	
6	1001223934	1	26E-L - (POR) DECAL,LOADS AND INSTRUCTION26E-L - (ENG) DECAL,LOADS AND INSTRUCTION26E-L - (ENG) DECAL,LOADS AND INSTRUCTION / 26E-L - (POR) AUTOCOLLANT, CHARGES ET CONSIGNES	
7	1001223864	1	26E-L - DECAL,WHEEL LOAD / 26E-L - AUTOCOLLANT, CHARGE SUR ROUE	
	1001223685	Ref	26E - (ENG-SPA) DECALS LOADS / 26E - (ENG-SPA) AUTOCOLLANTS CHARGES	A
4	1001223849	1	26E - (ENG-SPA) DECAL,LOADS AND INSTRUCTION / 26E - (ENG-SPA) AUTOCOLLANT, CHARGES ET CONSIGNES	
5	1001223853	1	26E - (ENG) DECAL,LOADS AND INSTRUCTION / 26E - (ENG) AUTOCOLLANT, CHARGES ET CONSIGNES	
6	1001223935	1	26E - (SPA) DECAL,LOADS AND INSTRUCTION / 26E - (SPA) AUTOCOLLANT, CHARGES ET CONSIGNES	
7	1001223863	1	26E - DECAL,WHEEL LOAD / 26E - AUTOCOLLANT, CHARGE SUR ROUE	
	1001223686	Ref	26E-L - (ENG-SPA) DECALS LOADS / 26E-L - (ENG-SPA) AUTOCOLLANTS CHARGES	A
4	1001223850	1	26E-L - (ENG-SPA) DECAL,LOADS AND INSTRUCTION / 26E-L - (ENG-SPA) AUTOCOLLANT, CHARGES ET CONSIGNES	
5	1001223854	1	26E-L - (ENG) DECAL,LOADS AND INSTRUCTION / 26E-L - (ENG) AUTOCOLLANT, CHARGES ET CONSIGNES	
6	1001223936	1	26E-L - (SPA) DECAL,LOADS AND INSTRUCTION / 26E-L - (SPA) AUTOCOLLANT, CHARGES ET CONSIGNES	
7	1001223864	1	26E-L - DECAL,WHEEL LOAD / 26E-L - AUTOCOLLANT, CHARGE SUR ROUE	
	1001223687	Ref	26E - (ENG-FRE) DECALS LOADS / 26E - (ENG-FRE) AUTOCOLLANTS CHARGES	A
4	1001223851	1	26E - (ENG-FRE) DECAL,LOADS AND INSTRUCTION / 26E - (ENG-FRE) AUTOCOLLANT, CHARGES ET CONSIGNES	
5	1001223853	1	26E - (ENG) DECAL,LOADS AND INSTRUCTION / 26E - (ENG) AUTOCOLLANT, CHARGES ET CONSIGNES	
6	1001223937	1	26E - (FRE) DECAL,LOADS AND INSTRUCTION / 26E - (FRE)	

SECTION 9 - DECALS INSTALL / INSTALLATION AUTOCOLLANTS

ITEM	PART NUMBER	QTY	DESCRIPTION	REV
7	1001223863	1	AUTOCOLLANT, CHARGES ET CONSIGNES 26E - DECAL,WHEEL LOAD / 26E - AUTOCOLLANT, CHARGE SUR ROUE	
	1001223688	Ref	26E-L - (ENG-FRE) DECALS LOADS / 26E-L - (ENG-FRE) AUTOCOLLANTS CHARGES	A
4	1001223852	1	26E-L - (ENG-FRE) DECAL,LOADS AND INSTRUCTION / 26E-L - (ENG-FRE) AUTOCOLLANT, CHARGES ET CONSIGNES	
5	1001223854	1	26E-L - (ENG) DECAL,LOADS AND INSTRUCTION / 26E-L - (ENG) AUTOCOLLANT, CHARGES ET CONSIGNES	
6	1001223938	1	26E-L - (FRE) DECAL,LOADS AND INSTRUCTION / 26E-L - (FRE) AUTOCOLLANT, CHARGES ET CONSIGNES	
7	1001223864	1	26E-L - DECAL,WHEEL LOAD / 26E-L - AUTOCOLLANT, CHARGE SUR ROUE	
	1001211411	Ref	DECALS AUSTRALIA / AUTOCOLLANTS AUSTRALIE	G
	1001219323	Ref	DECALS EUROPA / AUTOCOLLANTS EUROPE	E
8	AU2108	4	DECAL, CRUSHING / AUTOCOLLANT, ECRASEMENT	
9	1703814	4	DECAL, TIE DOWN / AUTOCOLLANT, ARRIMAGE	
10	AU2107	2	DECAL, HAND CRUSHING HAZARD / AUTOCOLLANT, COINCEMENT MAIN	
11	AU2103	3	DECAL, ELECTROCUTION / AUTOCOLLANT, ELECTROCUTION	
12	1703811	2	DECAL, LIFTING LUG / AUTOCOLLANT, ANNEAU DE LEVAGE	
13	AU2098	2	DECAL, INSERT FORKS / AUTOCOLLANT, PRISES DE FOURCHE	
14	1701499	2	TIE DOWN DECAL / AUTOCOLLANT, ARRIMAGE	
15	1706764	2	DECAL, JLG.COM / AUTOCOLLANT, JLG.COM	
16	1001227848	1	DECAL,MANUAL / AUTOCOLLANT, MANUEL	
17	1704016	2	DECAL, FORKLIFT LOCATION / AUTOCOLLANT, PRISE FOURCHE	
18	AU0149	4	DECAL REP DRIVE DIRECTION / AUTOCOLLANT, REP SENS MARCHE	
19	AU2105	3	DECAL, NO KARCHER / AUTOCOLLANT, KARCHER	
20	1706493	1	DECAL, DROP BAR / AUTOCOLLANT, RISQUE DE CHUTE SOUS-LISSE	
21	1705803	1	DECAL, ELEC HAZARD / AUTOCOLLANT, RISQUES ELECTRIQUES	
22	AU2229	1	DECAL,BATTERY CHARGER PLUG / AUTOCOLLANT, PRISE CHARGEUR	
23	AU1423	1	DECAL, FILTER CHANGE DECAL / AUTOCOLLANT, CHANGEMENT DE FILTRE	
24	AU2097	1	DECAL, OIL LEVEL / AUTOCOLLANT, NIVEAU D'HUILE	
25	AU2099	1	DECAL, MANUAL SWING / AUTOCOLLANT, ORIENTATION MANUELLE	
26	1001245244	1	DECAL,MAST MANUAL DESCENT / AUTOCOLLANT, DESCENTE MANUELLE MAT	
27	1706740	1	DECAL, BATTERY DISCONNECT / AUTOCOLLANT, DECONNEXION BATTERIE	
28	1704277	1	DECAL, LANYARD ATTACH / AUTOCOLLANT, ATTACHE HARNAIS	
29	1001214288	1	DECAL,TIE DOWN & LIFTING / AUTOCOLLANT, ARRIMAGE-ELINGAGE	
30	1001217094	1	DECAL,EMERGENCY CONTROLS / AUTOCOLLANT, SECOURS	
31	AU2215	1	DECAL,SLACK CHAIN DETECTION / AUTOCOLLANT, MOU DE CHAINE	
32	4420051	1 m 0.4	DECAL,WARNING STRIPES / AUTOCOLLANT, BANDE	

SECTION 9 - DECALS INSTALL / INSTALLATION AUTOCOLLANTS

ITEM	PART NUMBER	QTY	DESCRIPTION	REV
			JAUNE/NOIRE	
33	1001278484	1	DECAL,BAR CODE ASSY / KIT AUTOCOLLANTS CODE BARRE	
33	1001278485	1	DECAL,BAR-CODE / AUTOCOLLANT CODE BARRE	
33	1703632	1	DECAL,OVERLAY / PROTECTION ADHESIVE	
34	1001226413	1	DECAL, JIB MANUAL DESCENT / AUTOCOLLANT, DESCENTE BRAS	
0	1001223677	1	DECALS ANSI ENGLISH / AUTOCOLLANTS ANSI ANGLAIS	E
0	1001223678	1	DECALS ANSI SPANISH-PORTUGUESE / AUTOCOLLANTS ANSI ESPAGNOL-PORTUGAIS	D
0	1001223679	1	DECALS ANSI ENGLISH-SPANISH / AUTOCOLLANTS ANSI ANGLAIS-ESPAGNOL	D
0	1001223680	1	DECALS CSA ENGLISH-FRENCH / AUTOCOLLANTS CSA ANGLAIS-FRANCAIS	E
8	AU2117	4	ENG-DECAL, CRUSHING HAZARD / ENG-AUTOCOLLANT, ECRASEMENT	
8	AU2149	4	SPA-DECAL, CRUSHING HAZARD / SPA-AUTOCOLLANT, ECRASEMENT	
9	1703814	4	DECAL,TIE DOWN / AUTOCOLLANT, ARRIMAGE	
10	AU2119	2	ENG-DECAL,HAND CRUSHING HAZARD / ENG-AUTOCOLLANT, COINCEMENT MAIN	
10	AU2147	2	SPA-DECAL,HAND CRUSHING HAZARD / SPA-AUTOCOLLANT, COINCEMENT MAIN	
11	AU2118	3	ENG-DECAL,ELECTROCUTION HAZARD / ENG-AUTOCOLLANT, ELECTROCUTION	
11	AU2150	3	SPA-DECAL,ELECTROCUTION HAZARD / SPA-AUTOCOLLANT, ELECTROCUTION	
12	1703811	2	DECAL,LIFTING LUG / AUTOCOLLANT, ANNEAU DE LEVAGE	
13	AU2098	2	DECAL, INSERT FORKS / AUTOCOLLANT, PRISE FOURCHE	
14	1701499	2	TIE DOWN DECAL / AUTOCOLLANT, ARRIMAGE	
15	1704885	2	DECAL,WEBSITE / AUTOCOLLANT, SITE WEB	
16	1001227848	1	DECAL,MANUAL / AUTOCOLLANT, MANUEL	
17	1704016	2	DECAL,FORK LIFT / AUTOCOLLANT, PRISE FOURCHE	
18	AU0149	4	DECAL REP DRIVE DIRECTION / AUTOCOLLANT, REP SENS MARCHE	
19	AU2105	3	DECAL, NO KARCHER / AUTOCOLLANT, KARCHER	
20	1706493	1	DECAL,DROP BAR / AUTOCOLLANT, RISQUE DE CHUTE SOUS-LISSE	
21	1703785	1	ENG-DECAL,WARNING FIRE HAZARD / ENG-AUTOCOLLANT, RISQUES EXPLOSION	
21	1704031	1	FRE-DECAL,WARNING FIRE HAZARD / FRE-AUTOCOLLANT, RISQUES EXPLOSION	
22	AU2229	1	DECAL,BATTERY CHARGER PLUG / AUTOCOLLANT, PRISE CHARGEUR	
23	AU1423	1	FILTER CHANGE DECAL / AUTOCOLLANT, CHANGEMENT DE FILTRE	
24	AU2097	1	DECAL, OIL LEVEL / AUTOCOLLANT, NIVEAU D'HUILE	
25	AU2099	1	DECAL, MANUAL SWING / AUTOCOLLANT, ORIENTATION MANUELLE	
26	1001245244	1	DECAL,MAST MANUAL DESCENT / AUTOCOLLANT, DESCENTE MANUELLE MAT	
27	1706740	1	DECAL,BATTERY DISCONNECT / AUTOCOLLANT, DECONNEXION BATTERIE	
28	1704277	1	DECAL,LANYARD ATTACH / AUTOCOLLANT, ATTACHE HARNAIS	
29	1001214288	1	DECAL,TIE-DOWN & LIFTING / AUTOCOLLANT, ARRIMAGE-	

SECTION 9 - DECALS INSTALL / INSTALLATION AUTOCOLLANTS

ITEM	PART NUMBER	QTY	DESCRIPTION	REV
			ELINGAGE	
30	1001226415	1	DECAL,EMERGENCY CONTROLS / AUTOCOLLANT, SECOURS	
31	AU2215	1	DECAL,SLACK CHAIN DETECTION / AUTOCOLLANT, MOU DE CHAINE	
33	1001278484	1	DECAL,BAR CODE ASSY / KIT AUTOCOLLANTS CODE BARRE	
33	1001278485	1	DECAL,BAR CODE / AUTOCOLLANT CODE BARRE	
33	1703632	1	DECAL,OVERLAY / PROTECTION ADHESIVE	
34	1001226413	1	DECAL,JIB MANUAL DESCENT / AUTOCOLLANT, DESCENTE BRAS	
35	1001224025	1	DECAL, JIB MANUAL RAISING / AUTOCOLLANT MONTEE BRAS	
36	AU2154	4	POR-DECAL, CRUSHING HAZARD / POR-AUTOCOLLANT, ECRASEMENT	
36	AU2149	4	SPA-DECAL, CRUSHING HAZARD / SPA-AUTOCOLLANT, ECRASEMENT	
36	AU2143	4	FRE-DECAL, CRUSHING HAZARD / FRE-AUTOCOLLANT, ECRASEMENT	
37	AU2155	3	POR-DECAL, ELECTROCUTION HAZARD / POR-AUTOCOLLANT, ELECTROCUTION	
37	AU2150	3	SPA-DECAL, ELECTROCUTION HAZARD / SPA-AUTOCOLLANT, ELECTROCUTION	
37	AU2144	3	FRE-DECAL, ELECTROCUTION HAZARD / FRE-AUTOCOLLANT, ELECTROCUTION	
38	1704023	1	POR-DECAL,WARNING FIRE HAZARD / POR-AUTOCOLLANT, RISQUES EXPLOSION	
38	1704031	1	SPA-DECAL,WARNING FIRE HAZARD / SPA-AUTOCOLLANT, RISQUES EXPLOSION	
38	AU2145	1	FRE-DECAL,WARNING FIRE HAZARD / FRE-AUTOCOLLANT, RISQUES EXPLOSION	
39	AU2152	2	POR-DECAL,HAND CRUSHING HAZARD / POR-AUTOCOLLANT, COINCEMENT MAIN	
39	AU2147	2	SPA-DECAL,HAND CRUSHING HAZARD / SPA-AUTOCOLLANT, COINCEMENT MAIN	
39	AU2140	2	FRE-DECAL,HAND CRUSHING HAZARD / FRE-AUTOCOLLANT, COINCEMENT MAIN	
41	1001231801	1	DECAL,WARNING PROP 65 / AUTOCOLLANT ATTENTION PROP 65	

SECTION 10 - OPTIONS / OPTIONS

SECTION 10 - OPTIONS / OPTIONS

FIGURE 10-1. SKYLINE BEACON INSTALL / INSTALLATION FEU SKYLINE

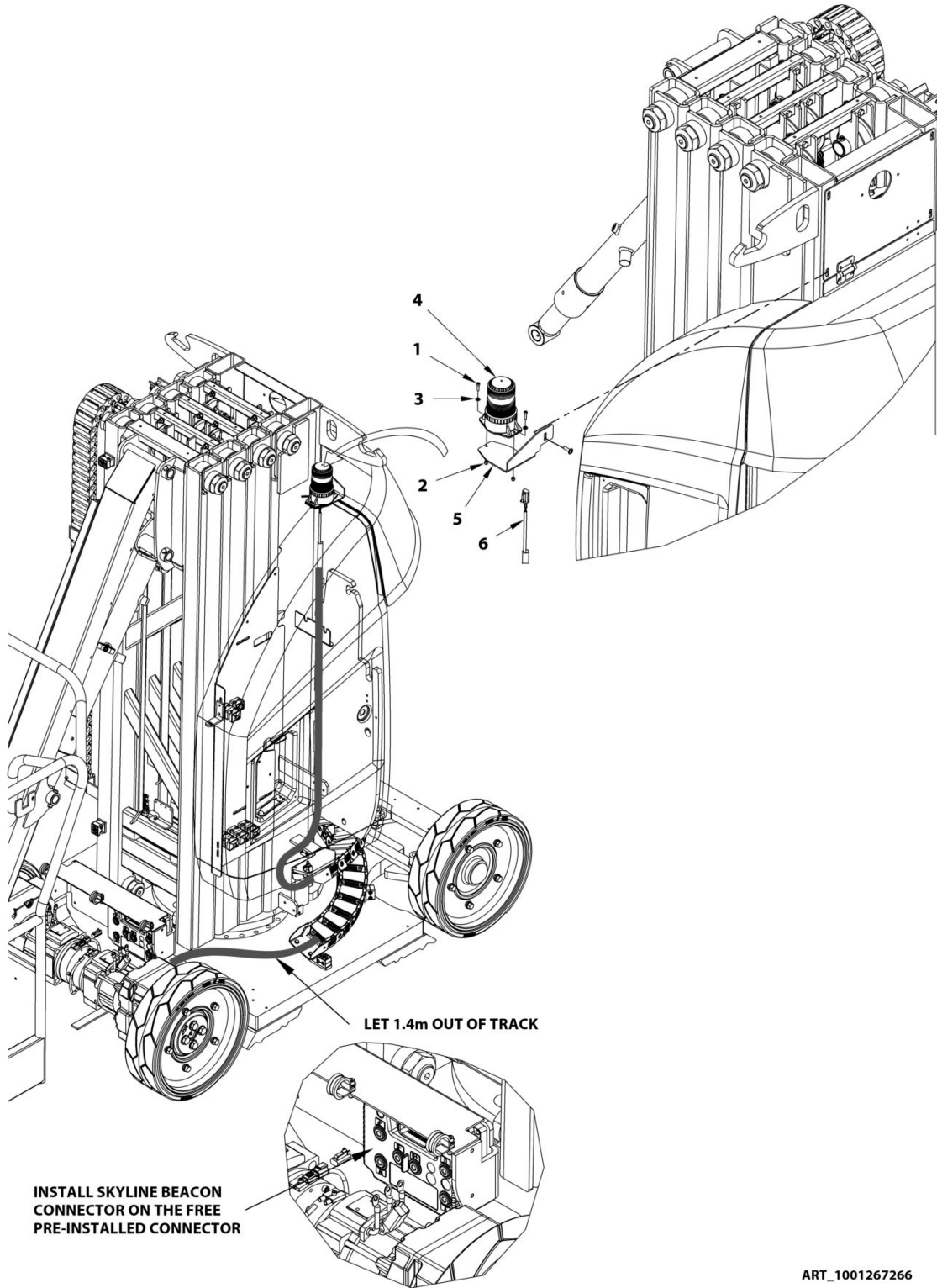

ART_1001267266

SECTION 10 - OPTIONS / OPTIONS

FIGURE 10-1. SKYLINE BEACON INSTALL / INSTALLATION FEU SKYLINE

ITEM	PART NUMBER	QTY	DESCRIPTION	REV
	1001267266	Ref	SKYLINE BEACON INSTALL / INSTALLATION FEU SKYLINE	A
1	000085	2	M04x16 8.8 SOCKET HEAD MACH SCREW / VIS CHC M04x16 8.8 BI FT	
2	110001	2	M04 GR. 8.8 LOCK NUT / ECROU FREIN M4 CL08 BI	
3	120024	2	LOCK WASHER D04x10 / RONDELLE CONTACT M4 BI	
4	1001200910	1	LAMP,BLUE BEACON / FEU BLEU	
5	1001257866	1	BRACKET,ALERT BEACON / SUPPORT FEU BLEU	
6	1001267261	1	HARNES,ALERT BEACON BLUE / FAISCEAU FEU BLEU	

SECTION 10 - OPTIONS / OPTIONS

FIGURE 10-2. INSTALL, PEDAL FOR JAPAN / INSTALLATION PEDALE POUR JAPON

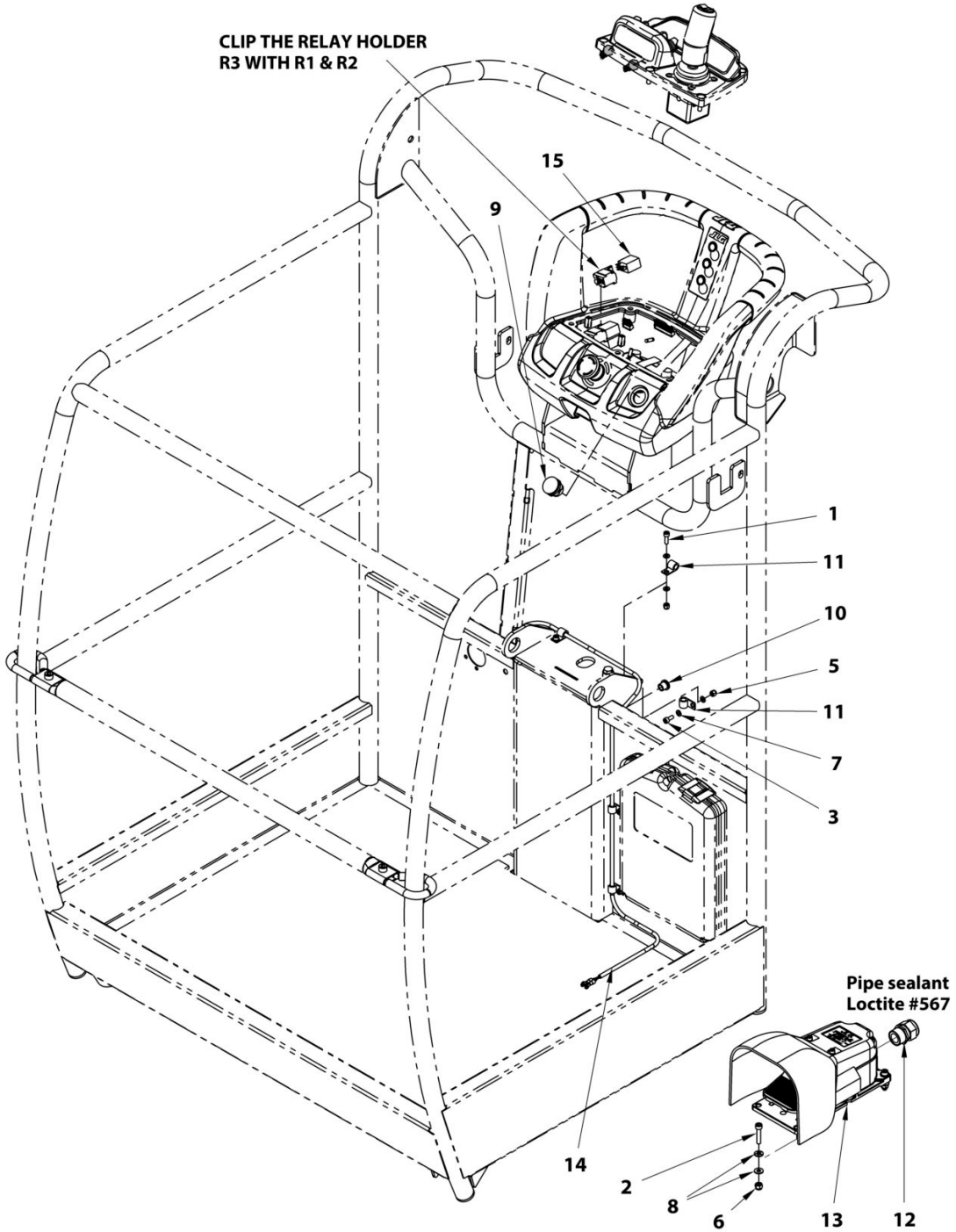

ART_1001267669

SECTION 10 - OPTIONS / OPTIONS

FIGURE 10-2. INSTALL,PEDAL FOR JAPAN / INSTALLATION PEDALE POUR JAPON

ITEM	PART NUMBER	QTY	DESCRIPTION	REV
	1001267669	Ref	INSTALL PEDAL FOR JAPAN / INSTALLATION PEDALE POUR JAPON	A
1	000003	2	M05x16 8.8 SOCKET HEAD MACH SCREW / VIS CHC M05x16 8.8 BI FT	
2	000016	3	M06x30 8.8 SOCKET HEAD MACH SCREW / VIS CHC M06x30 8.8 BI FT	
3	000067	3	M05x12 8.8 SOCKET HEAD MACH SCREW / VIS CHC M05x12 8.8 BI FT	
5	110002	5	M05 GR. 8.8 LOCK NUT / ECROU FREIN M5 CL08 BI	
6	110003	3	M06 GR. 8.8 LOCK NUT / ECROU FREIN M6 CL08 BI	
7	120002	10	M05 WASHER / RONDELLE M05 BI	
8	120009	6	LOCK WASHER D06x14 / RONDELLE CONTACT dD 06x14 BI	
9	210052	1	SWITCH,SHUTTER / BOUCHON D22.5	
10	250051	1	CHANNEL D11.5 / PASSE FIL D11.5	
11	1321293	5	CLAMP,INSULATED BAND / COLLIER ISOLE	
12	4460071	1	CONNECTOR,WATER TIGHT / PRESSE ETOUPE	
13	1001117172	1	PEDAL / PEDALE	
14	1001267644	1	HARNESS,PEDAL / FAISCEAU PEDALE	
15	1001230297	1	RELAY,TYCO 24V / RELAIS TYCO 24V	

SECTION 10 - OPTIONS / OPTIONS

FIGURE 10-3. MOTION ALARM INSTALL / INSTALLATION ALARME DE MOUVEMENT

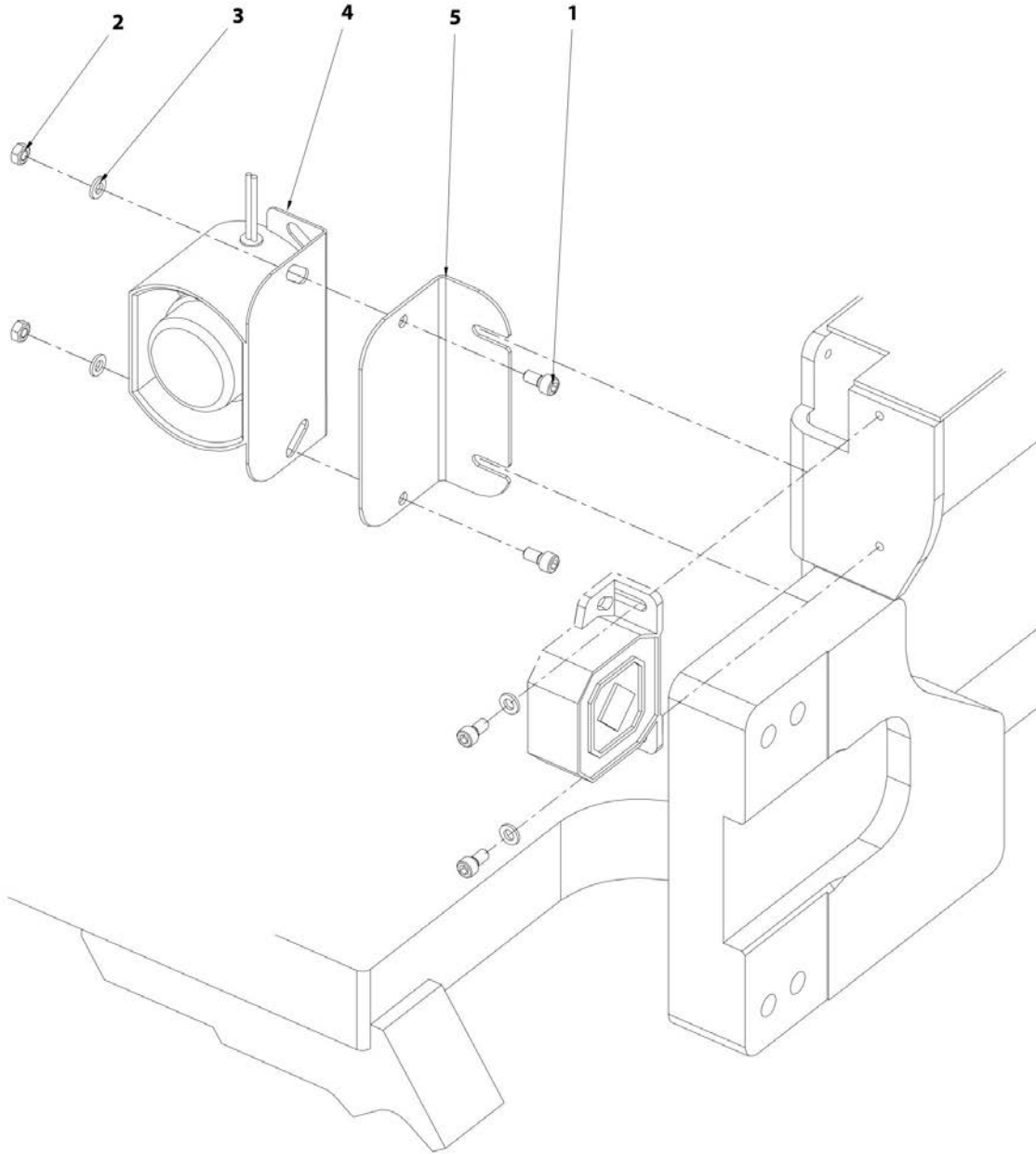

ART_OP509

SECTION 10 - OPTIONS / OPTIONS

FIGURE 10-3. MOTION ALARM INSTALL / INSTALLATION ALARME DE MOUVEMENT

ITEM	PART NUMBER	QTY	DESCRIPTION	REV
	OP509		MOTION ALARM INSTALL / INSTALLATION ALARME DE MOUVEMENT	A
1	000014	2	M06x12 8.8 SOCKET HEAD MACH SCREW / VIS CHC M06x12 8.8 BI FT	
2	110003	2	M06 GR08 LOCK NUT / ECROU FREIN M6 CL08 BI	
3	120009	2	dD 06x14 LOCK WASHER / RONDELLE CONTACT dD 06x14 BI	
4	PC0466	1	HARNESS,MOTION ALARM / FAISCEAU ALARME DE MOUVEMENT	
5	ST3022	1	MOTION ALARM BRACKET / EQUERRE ALARME DE MOUVEMENTS	

SECTION 10 - OPTIONS / OPTIONS

FIGURE 10-4. 230V PLATFORM SOCKET INSTALL / INSTALLATION PRISE PLATE-FORME 230V

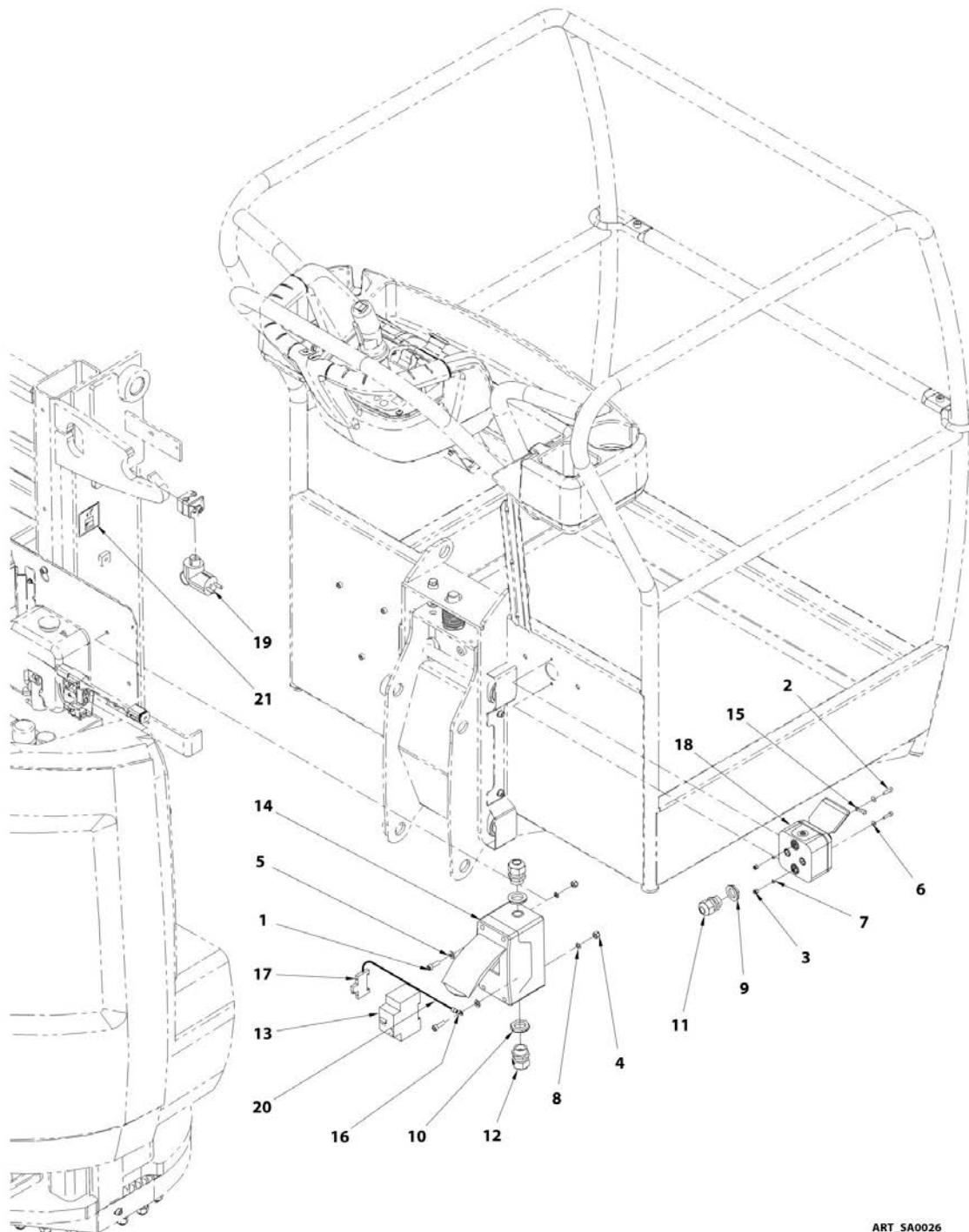

ART_SA0026

SECTION 10 - OPTIONS / OPTIONS

FIGURE 10-4. 230V PLATFORM SOCKET INSTALL / INSTALLATION PRISE PLATE-FORME 230V

ITEM	PART NUMBER	QTY	DESCRIPTION	REV
	SA0026	Ref	PLATFORM 230V FRENCH SOCKET INSTALL / INSTALLATION PRISE PANIER FRANCE 230V	D
	SA0027	Ref	PLATFORM 230V GERMAN SOCKET INSTALL / INSTALLATION PRISE PANIER ALLEMAGNE 230V	D
1	000005	2	M06x20 8.8 SOCKET HEAD MACH SCREW / VIS CHC M06x20 8.8 BI FT	
2	000085	2	M04x16 8.8 SOCKET HEAD MACH SCREW / VIS CHC M04x16 8.8 BI FT	
3	110001	2	M04 GR08 LOCK NUT / ECROU FREIN M4 CL08 BI	
4	110003	2	M06 GR08 LOCK NUT / ECROU FREIN M6 CL08 BI	
5	120009	2	dD 06x14 LOCK WASHER / RONDELLE CONTACT dD 06x14 BI	
6	120024	2	M4 LOCK WASHER / RONDELLE CONTACT M4 BI	
7	120058	2	WASHER, D4 SERRATED LOCK / RONDELLE EVENTAIL D4	
8	120060	2	WASHER, D6 SERRATED LOCK / RONDELLE EVENTAIL D6	
9	210011	1	GLAND N°13 NUT / ECROU DE PRESSE ETOUPE N°13	
10	210012	2	GLAND N°16 NUT / ECROU DE PRESSE ETOUPE N°16	
11	210019	1	GLAND N°13 / PRESSE ETOUPE N°13	
12	210021	2	GLAND N°16 / PRESSE ETOUPE N°16	
13	1001181045	1	CUTOUT 30 mA / DISJONCTEUR DIFFERENTIEL 30 mA	
14	240093	1	CUTOUT BOX / BOITIER DISJONCTEUR	
15	250089	1	M4 EYELET TERMINAL 1-2.5mm ² / COSSE A OEIL ISOLEE M4 - 1-2.5mm ²	
16	250091	1	M6 EYELET TERMINAL 1-2.5mm ² / COSSE A OEIL ISOLEE M6 - 1-2.5mm ²	
17	250135	1	TERMINAL BLOCK VICKING / BLOC DE JONCTION VICKING	
18	260029	1	FRENCH 230 VAC SOCKET 2P+T / PRISE FEM. FRANCAISE 230VAC 2P+T	
18	260187	1	GERMAN 230 VAC SOCKET 2P+T / PRISE FEM. ALLEMANDE 230VAC 2P+T	
19	260214	1	FRENCH AND GERMAN 230V CONNECTOR / PRISE 230V FRANCAISE ET ALLEMANDE	
20	270002	0.4	WIRE 2 mm ² Y/G (qty indicated in meter) / FIL 2 mm ² V/J (qté indiquée en mètre)	
21	AU1716	1	PLATFORM SOCKET DECAL / AUTOCOLLANT PRISE PANIER	

SECTION 10 - OPTIONS / OPTIONS

FIGURE 10-5. PLATFORM 115V GFI-US SOCKET INSTALL / INSTALLATION PRISE PLATE-FORME 115V GFI-US

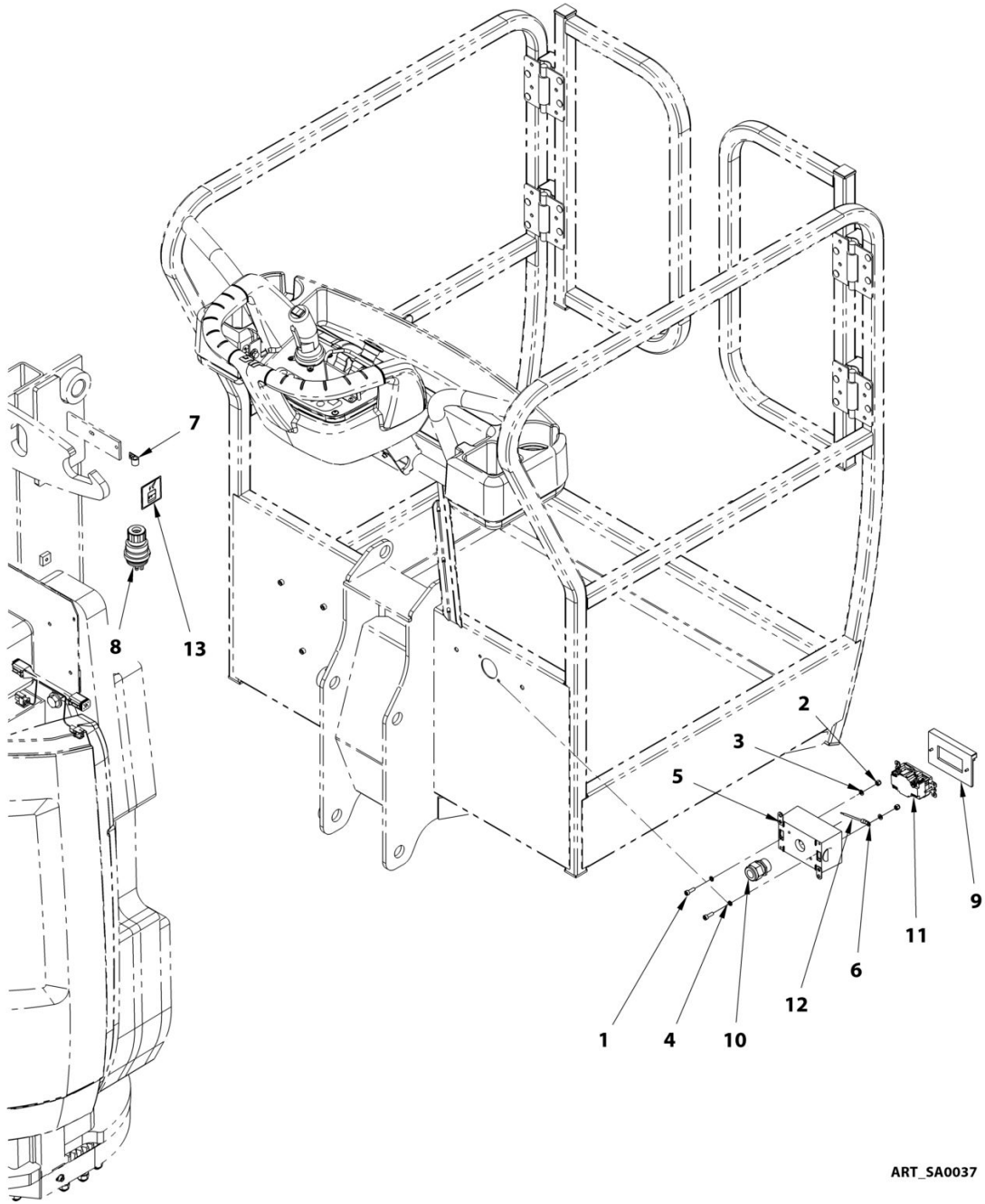

ART_SA0037

SECTION 10 - OPTIONS / OPTIONS

FIGURE 10-5. PLATFORM 115V GFI-US SOCKET INSTALL / INSTALLATION PRISE PLATE-FORME 115V GFI-US

ITEM	PART NUMBER	QTY	DESCRIPTION	REV
	SA0037		PLATFORM 115V GFI-US SOCKET INSTALL / INSTALLATION PRISE PLATE-FORME 115V GFI-US	B
1	000003	2	M05x16 8.8 SOCKET HEAD MACH SCREW / VIS CHC M05x16 8.8 BI FT	
2	110002	2	M05 GR08 LOCK NUT / ECROU FREIN M5 CL08 BI	
3	120002	2	M05 WASHER / RONDELLE M05 BI	
4	120059	2	WASHER, D5 SERRATED LOCK / RONDELLE EVENTAIL D5	
5	230016	1	ELECTRICAL BOX / BOITIER ELECTRIQUE	
6	250090	1	M5 EYELET TERMINAL 1-2.5mm ² / COSSE A OEIL ISOLEE M5 - 1-2.5mm ²	
7	1321293	1	CLAMP, INSULATED BAND / COLLIER ISOLE	
8	260276	1	US 125 VAC MALE CONNec. (=7364002824) / PRISE US 125VAC (=7364002824)	
9	4060700	1	CIRCUIT BREAKER COVER / COUVERCLE COUPE CIRCUIT	
10	4460071	1	CONNECTOR, WATER TIGHT / PRESSE ETOUPE	
11	4460346	1	CIRCUIT BREAKER KIT / KIT COUPE CIRCUIT	
12	270002	0.2	WIRE 2 mm ² Y/G (qty indicated in meter) / FIL 2 mm ² V/J (qté indiquée en mètre)	
13	AU1716	1	PLATFORM SOCKET DECAL / AUTOCOLLANT PRISE PANIER	

SECTION 10 - OPTIONS / OPTIONS

FIGURE 10-6. 115V IEC PLATFORM SOCKET INSTALL / INSTALLATION PRISE PLATE-FORME 115V EIC

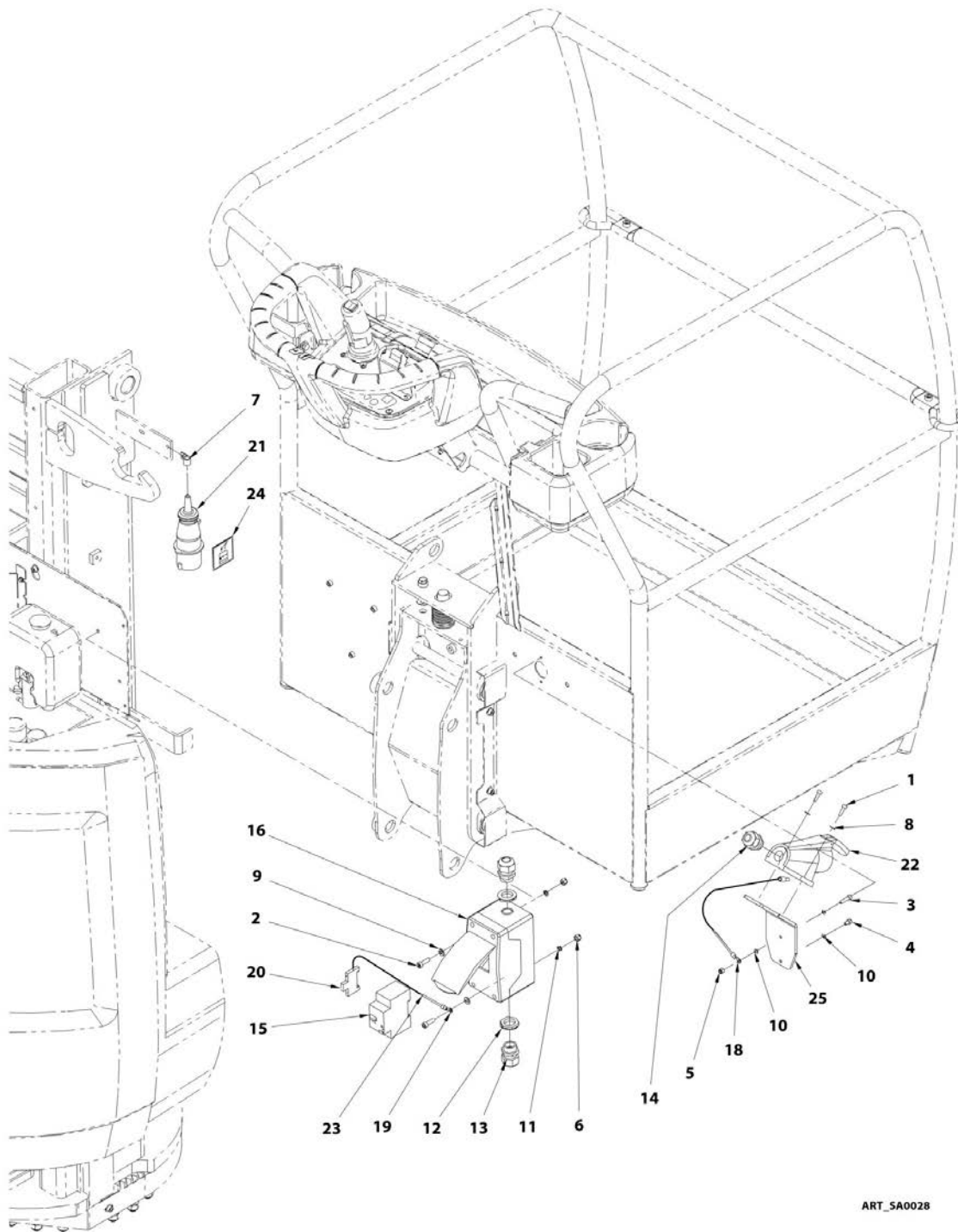

ART_SA0028

SECTION 10 - OPTIONS / OPTIONS

**FIGURE 10-6. 115V IEC PLATFORM SOCKET INSTALL / INSTALLATION PRISE PLATE-FORME115V
EIC**

ITEM	PART NUMBER	QTY	DESCRIPTION	REV
	SA0028		115V IEC PLATFORM SOCKET INSTALL / INSTALLATION PRISE PANIER IEC 115V	D
1	000003	2	M05x16 8.8 SOCKET HEAD MACH SCREW / VIS CHC M05x16 8.8 BI FT	
2	000005	2	M06x20 8.8 SOCKET HEAD MACH SCREW / VIS CHC M06x20 8.8 BI FT	
3	000010	1	M05x20 8.8 SOCKET HEAD MACH SCREW / VIS CHC M05x20 8.8 BI FT	
4	000089	1	M05x08 8.8 SOCKET HEAD MACH SCREW / VIS CHC M05x08 8.8 BI FT	
5	110002	1	M05 GR08 LOCK NUT / ECROU FREIN M5 CL08 BI	
6	110003	2	M06 GR08 LOCK NUT / ECROU FREIN M6 CL08 BI	
7	1321293	1	CLAMP, INSULATED BAND / COLLIER ISOLE	
8	120002	2	M05 WASHER / RONDELLE M05 BI	
9	120009	2	dD 06x14 LOCK WASHER / RONDELLE CONTACT dD 06x14 BI	
10	120059	3	WASHER, D5 SERRATED LOCK / RONDELLE EVENTAIL D5	
11	120060	2	WASHER, D6 SERRATED LOCK / RONDELLE EVENTAIL D6	
12	210012	2	GLAND N°16 NUT / ECROU DE PRESSE ETOUPE N°16	
13	210021	2	GLAND N°16 / PRESSE ETOUPE N°16	
14	210066	1	M20 CABLE GLAND / PRESSE ETOUPE M20	
15	1001181045	1	CUTOUT 30 mA / DISJONCTEUR DIFFERENTIEL 30 mA	
16	240093	1	CUTOUT BOX / BOITIER DISJONCTEUR	
17	250071	1	INSULATED SOCKET TERMINAL Ø5 / COSSE CYLINDRIQUE FEM. ISOLEE Ø5	
18	250090	1	M5 EYELET TERMINAL 1-2.5mm ² / COSSE A OEIL ISOLEE M5 - 1-2.5mm ²	
19	250091	1	M6 EYELET TERMINAL 1-2.5mm ² / COSSE A OEIL ISOLEE M6 - 1-2.5mm ²	
20	250135	1	TERMINAL BLOCK VICKING / BLOC DE JONCTION VICKING	
21	260213	1	CONNECTOR 115VAC/16A IEC60309 / PRISE MALE 115VAC/16A CEI60309	
22	260258	1	115 VAC IEC60309 SURFACE SOCKET / PRISE FEMELLE FIXE 115VAC CEI60309	
23	270002	0.5	WIRE 2 mm ² Y/G (qty indicated in meter) / FIL 2 mm ² V/J (qté indiquée en mètre)	
24	AU1716	1	PLATFORM SOCKET DECAL / AUTOCOLLANT PRISE PANIER	
25	ST3212	1	PLATE, 115VAC SOCKET / PLATINE PRISE 115VAC	

SECTION 10 - OPTIONS / OPTIONS

FIGURE 10-7. INSTALL,PLATFORM OBSTACLE DETECTION / INSTALLATION DETECTION OBSTACLE

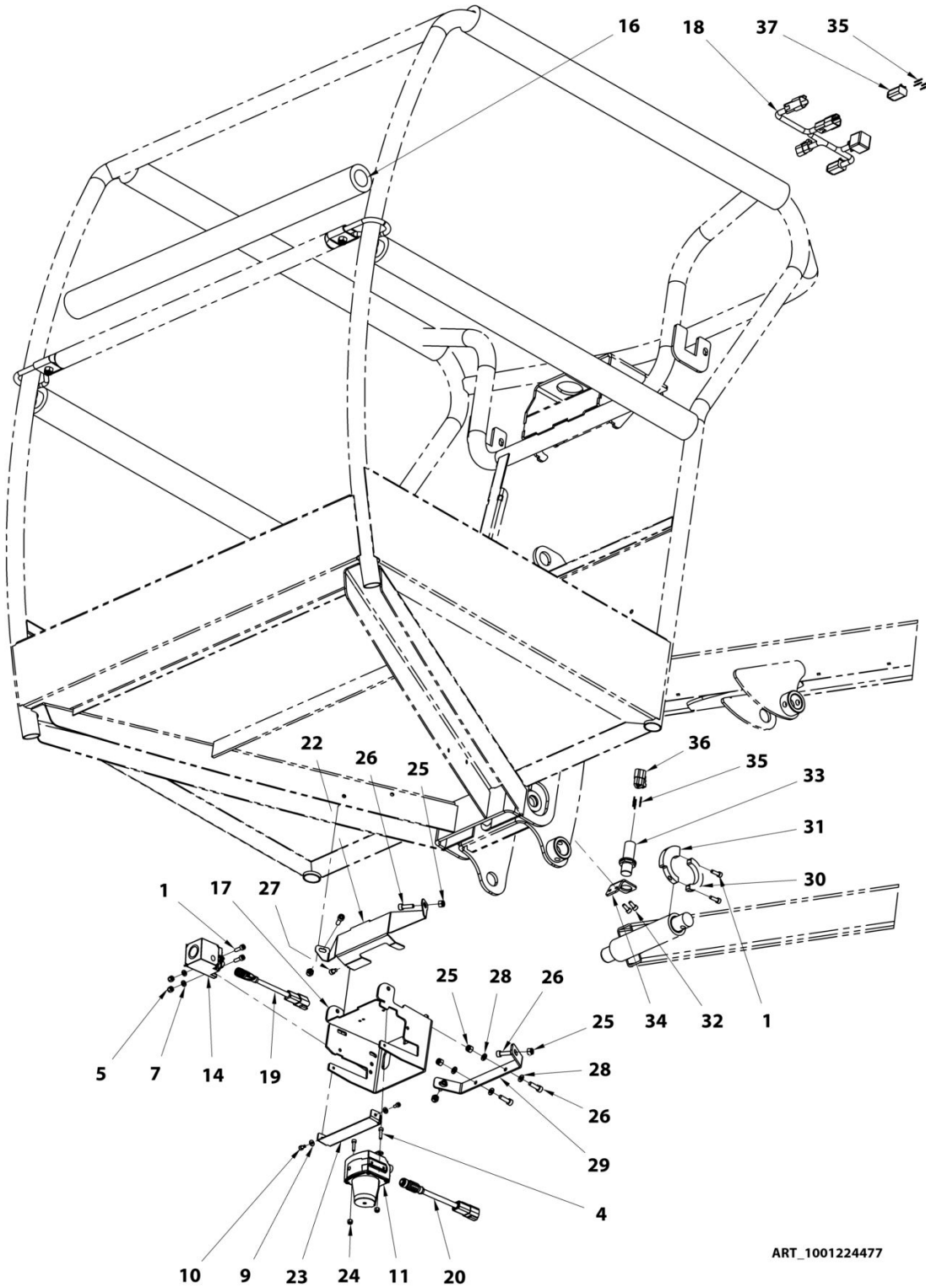

ART_1001224477

SECTION 10 - OPTIONS / OPTIONS

FIGURE 10-7. INSTALL,PLATFORM OBSTACLE DETECTION / INSTALLATION DETECTION OBSTACLE

ITEM	PART NUMBER	QTY	DESCRIPTION	REV
	1001224477		INSTALL,PLATFORM OBSTACLE DETECTION / INSTALLATION DECTECTION OBSTACLE	C
1	000003	4	M05x16 8.8 SOCKET HEAD MACH SCREW / VIS CHC M5x16 8.8 BI FT	
4	000085	2	M04x16 8.8 SOCKET HEAD MACH SCREW / VIS CHC M4x16 8.8 BI FT	
5	110002	2	M05 GR. 8.8 LOCK NUT / ECROU FREIN M5	
7	120002	2	M05 WASHER / RONDELLE M5	
9	120024	2	LOCK WASHER D04x10 / RONDELLE FREIN D4x10	
10	000090	2	M04x08 8.8 SOCKET HEAD MACH SCREW / VIS CHC M4x08 8.8 BI FT	
11	260339	1	SENSOR,2D LASER SCANNER / SCANNER LASER 2D	
14	260341	1	SENSOR,ULTRASONIC / DETECTEUR ULTRASON	
16	400087	5	INSULATION PIPE D30 INT. LENGTHH 1m / TUBE ISOLATION D30, LONGUEUR 1m	
17	1001229970	1	SUPPORT,OBSTACLE DETECTION / SUPPORT DECTECTION OBSTACLE	
18	1001227893	1	HARNESS,OBSTACLE DETECTION / FAISCEAU DECTECTION OBSTACLE	
19	PC0619	1	HARNESS,ULTRASONIC SENSOR / FAISCEAU DETECTEUR ULTRASON	
20	PC0618	1	HARNESS,LASER SENSOR / FAISCEAU DETECTEUR LASER	
22	1001229972	1	SUPPORT,OBSTACLE DETECTION / SUPPORT DECTECTION OBSTACLE	
23	1001229971	1	PLATE,LASER SENSOR PROTECTION / TOLE PROTECTION LASER	
24	110001	2	M04 GR. 8.8 LOCK NUT / ECROU FREIN M4	
25	110003	6	M06 GR. 8.8 LOCK NUT / ECROU FREIN M6	
26	000005	6	M06x20 8.8 SOCKET HEAD MACH SCREW / VIS CHC M6x20 8.8 BI FT	
27	000089	1	M05x08 8.8 SOCKET HEAD MACH SCREW / VIS CHC M5x08 8.8 BI FT	
28	120030	4	LOCK WASHER D06x12 / RONDELLE FREIN D6x12	
29	1001229973	1	SUPPORT,OBSTACLE DETECTION / SUPPORT DECTECTION OBSTACLE	
30	1001233658	1	PLATE,CLAMPING RING PART / DEMI COQUILLE SERRAGE	
31	1001233659	1	PLATE,JIB SENSOR CAM / CAME CAPTEUR BRAS	
32	000067	2	M05x12 8.8 SOCKET HEAD MACH SCREW / VIS CHC M5x12 8.8 BI FT	
33	4000007	1	SENSOR,PROXIMITY / DETECTEUR DE PROXIMITE	
34	1001233657	1	PLATE,SUPPORT SENSOR / TOLE SUPPORT DETECTEUR	
35	4460465	7	TERMINAL,DEUTSCH #16/#18 SOCKET / CONTACT DEUTSCH DT FEMELLE	
36	4460539	1	TERMINAL,3 PIN MALE / CONNECTEUR DEUTSCH DT 3P MALE	
37	4460884	1	PLUG,4-PIN CONNECTOR / CONNECTEUR DEUTSCH DT 4P MALE	

SECTION 10 - OPTIONS / OPTIONS

FIGURE 10-8. AIRLINE 5/16" INSTALL / INSTALLATION AIR COMPRIE 5/16"

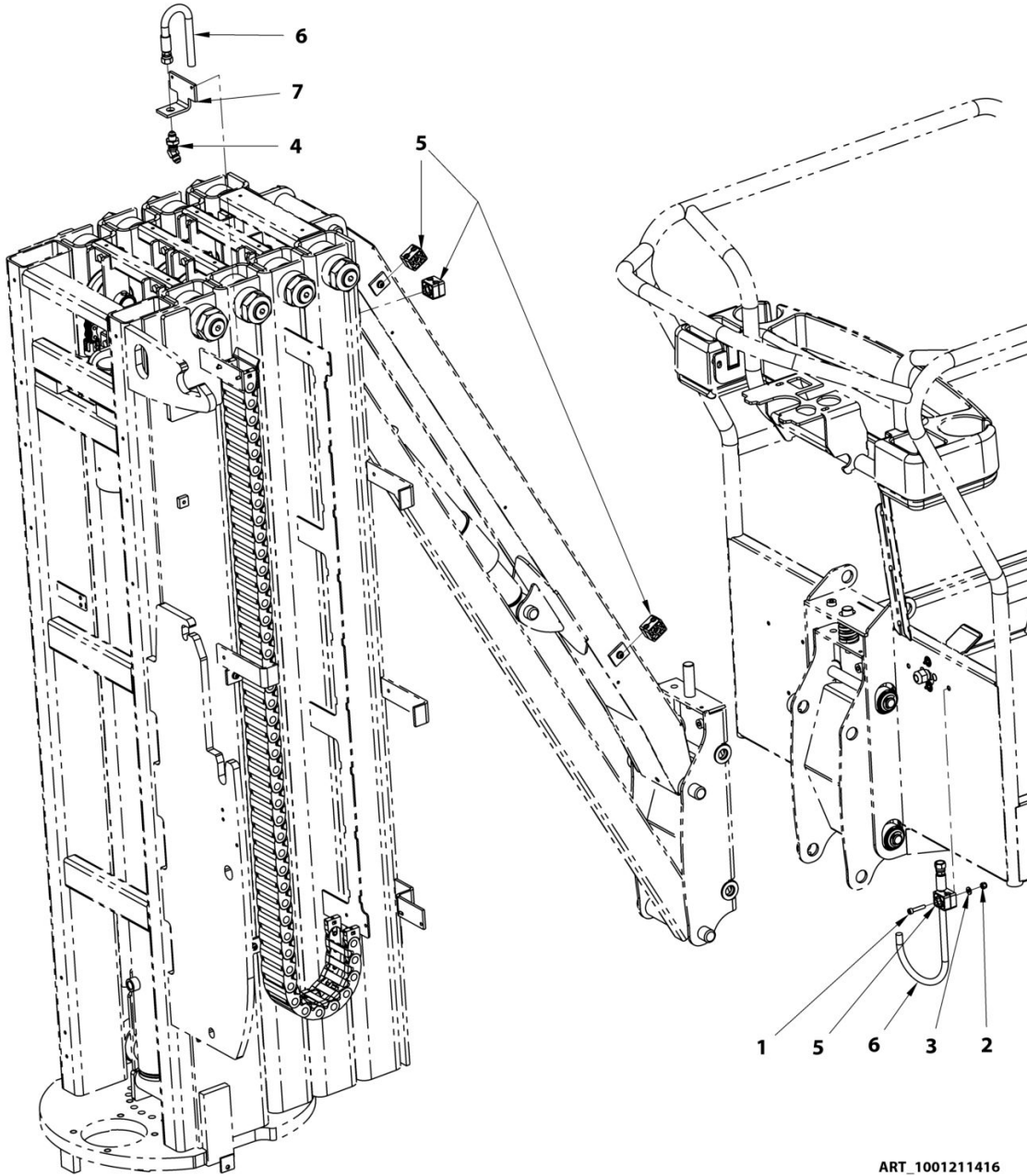

ART_1001211416

SECTION 10 - OPTIONS / OPTIONS

FIGURE 10-8. AIRLINE 5/16" INSTALL / INSTALLATION AIR COMPRIME 5/16"

ITEM	PART NUMBER	QTY	DESCRIPTION	REV
	1001211416		INSTALL,AIR LINE 5/16" / INSTALLATION AIR COMPRIME 5/16"	A
1	000016	1	M06x30 8.8 SOCKET HEAD MACH SCREW / VIS CHC M06x30 8.8 BI FT	
2	110003	1	M06 GR. 8.8 LOCK NUT / ECROU FREIN M6 CL08 BI	
3	120009	1	LOCK WASHER D06x14 / RONDELLE CONTACT dD 06x14 BI	
4	300161	1	45° BULKHEAD JIC 9/16 / TRAVERSEE DE CLOISON 45° JIC	
5	400018	4	CLAMP, TWIN D12 / COLLIER DOUBLE D12	
6	DF0978	1	HOSE 5/16-0830cm-JIC Fem 9/16-JIC Fem 9/16 / flexible 5/16-0830cm-JIC Fem 9/16-JIC Fem 9/16	
7	ST1969	1	SUPPORT, AIR LINE HOSE / SUPPORT FLEXIBLE AIR COMPRIME	

SECTION 10 - OPTIONS / OPTIONS

FIGURE 10-9. WORKING LIGHT INSTALL / INSTALLATION PHARE DE TRAVAIL

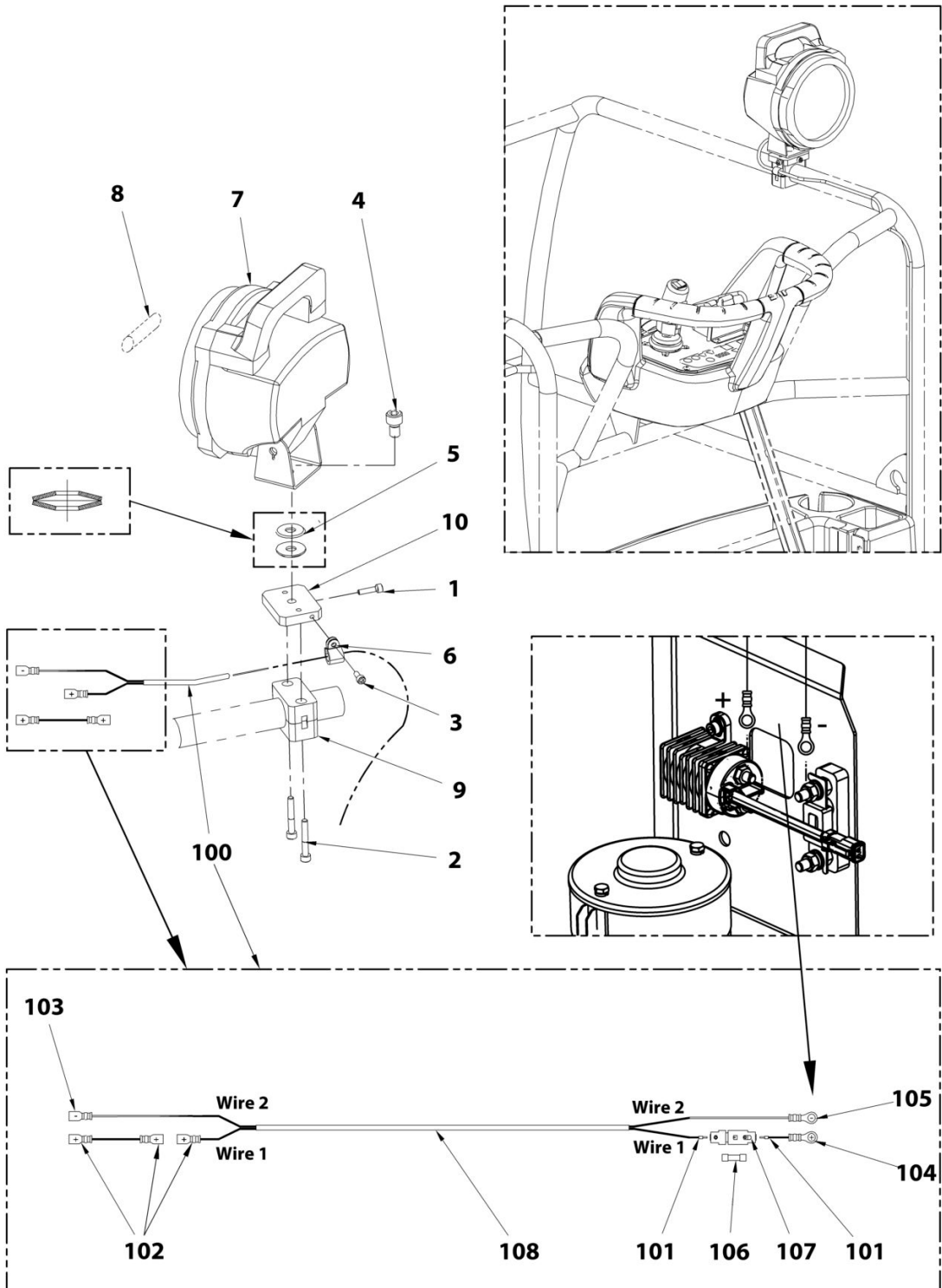

ART_OP521

SECTION 10 - OPTIONS / OPTIONS

FIGURE 10-9. WORKING LIGHT INSTALL / INSTALLATION PHARE DE TRAVAIL

ITEM	PART NUMBER	QTY	DESCRIPTION	REV
	OP521		WORKING LIGHT INSTALL / INSTALLATION PHARE DE TRAVAIL	B
1	000010	1	M05x20 8.8 SOCKET HEAD MACH SCREW / VIS CHC M05x20 8.8 BI FT	
2	000017	2	M06x40 8.8 SOCKET HEAD MACH SCREW / VIS CHC M06x40 8.8 BI FT	
3	000067	1	M05x12 8.8 SOCKET HEAD MACH SCREW / VIS CHC M05x12 8.8 BI FT	
4	000069	1	M10x16 8.8 SOCKET HEAD MACH SCREW / VIS CHC M10x16 8.8 BI FT	
5	120043	2	BEVEL WASHER Ø28x10.2x1 / RONDELLE RESSORT Ø28x10.2x1 BR	
6	1321293	1	CLAMP,INSULATED BAND / COLLIER ISOLE	
7	260144	1	24V 70W LIGHT / PHARE 24V 70W	
8	260146	1	BULB H3 / 70W / AMPOULE H3 / 70W	
9	400077	1	CLAMP, SINGLE D30 / COLLIER D30	
10	FX158-014	1	PLATFORM LIGHT PLATE / PLATINE PHARE DE TRAVAIL	
100	PC0528	1	HARNES,WORK LIGHT / FAISEAU PHARE DE TRAVAIL	
101	250001	2	FERRULE TERMINAL 1mm ² / EMBOUT 1mm ²	
102	250026	3	RED RECEPTACLE TERM. 6.3 - 0.5-1.2mm ² / COSSE FEMELLE 6.3 ROUGE - 0.5-1.2mm ²	
103	250027	1	BLUE RECEPTACLE TER. 6.3 - 1.5-2.5mm ² / COSSE FEM. 6.3 BLEUE 6.3 - 1.5-2.5mm ²	
104	250084	1	M8 EYELET TERMINAL 0.25-1mm ² / COSSE A OEIL ISOLEE M8 - 0.25-1mm ²	
105	250172	1	M08 EYELET TERMINAL 1-2.5mm ² / COSSE A OEIL ISOLEE M08 - 1-2.5mm ²	
106	260006	1	5x20 3.15A FUSE / FUSIBLE 5x20 3.15A	
107	260007	1	FUSE HOLDER / PORTE FUSIBLE	
108	270031	12.2m	CABLE 2x1mm ² / CABLE 2x1mm ²	

SECTION 10 - OPTIONS / OPTIONS

FIGURE 10-10. UCB PROTECTION INSTALL / INSTALLATION PROTECTION BOITIER HAUT

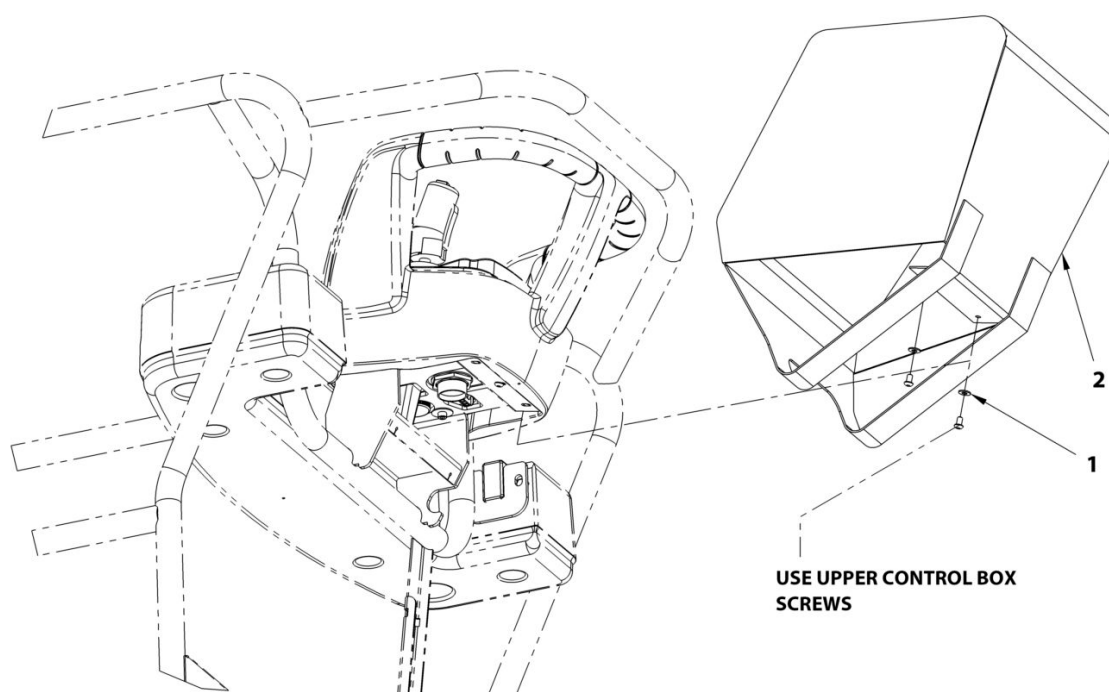

ART_1001214774

SECTION 10 - OPTIONS / OPTIONS

FIGURE 10-10. UCB PROTECTION INSTALL / INSTALLATION PROTECTION BOITIER HAUT

ITEM	PART NUMBER	QTY	DESCRIPTION	REV
	1001214774	Ref	UCB PROTECTION INSTALL / INSTALLATION PROTECTION BOITIER HAUT	A
1	120009	1	LOCK WASHER D06x14 / RONDELLE FREIN D06x14	
2	1001214777	2	UCB PROTECTION / PROTECTION BOITIER HAUT	

**SECTION 11 - RECOMMENDED PARTS LIST / LISTE DE PIÈCES
RECOMMANDÉES**

**SECTION 11 - RECOMMENDED PARTS LIST / LISTE DE PIÈCES
RECOMMANDÉES**

SECTION 11 - RECOMMENDED PARTS LIST / LISTE DE PIECES RECOMMANDEES

FIGURE 11-1. RECOMMENDED PARTS LIST / LISTE DE PIECES RECOMMANDEES

ITEM	PART NUMBER	QTY	DESCRIPTION	REV
	Note		The following list will service one Machine with emergency repair parts which can be installed in the field. Parts from the list should be replaced when inventory is depleted to keep service parts stock supplied. For further information, contact your JLG Industries Parts Department. / La liste suivante indique (pour une Machine) les pièces de réparation d'urgence qui peuvent être installées sur le terrain. La quantité de pièces de cette liste doit être tenue en stock minimum. Pour de plus amples informations, contactez votre SAV JLG Industries.	~Ref
		Ref	STANDARD PARTS / PIECES STANDARD	
	310103	1	BREATHER CAP / BOUCHON-RENIFLARD	
	3740150	1	RELAY, 24VDC/100A / RELAIS, 24VDC/100A	
	1001230297	2	RELAY,TYCO 24V / RELAIS TYCO 24V	
	2860030	1	KEY (INCLUDED IN ITEM 4360469) / CLE (COMPRISE DANS REF 4360469)	
	1001266902	1	SWITCH, MEMBRANE PAD 3 BUTTONS / INTERRUPTEURS A MEMBRANE 3 BOUTONS	
	260079	1	325A FUSE / FUSIBLE 325A	
	930134	1	FILTER, CARTRIDGE, 10µm / ELEMENT FILTRANT 10µm	
	7027367	1	SWITCH ENABLER / CONTACT VALIDATION	
	4360562	1	COMPLETE KNOB / ARRET D'URGENCE COMPLET	
	1001115919	1	SWITCH,PUSH BUTTON-ENABLE / B P DE VALIDATION	
	240056	1	NO CONTACT BASE / EMBASE CONTACT NO	
		Ref	VARIABLE PARTS / AUTRES PIECES	
	1001223812	1	KIT-SERVICE, GROUND PANEL W/O ENABLE / KIT SAV PLATINE BOITIER BAS SANS ENABLE	
	SE1202	1	KIT-SERVICE, GROUND PANEL WITH ENABLE / KIT SAV PLATINE BOITIER BAS AVEC ENABLE	
	260323	1	NO/NC SWITCH PG11 / CAPTEUR NO/NF PE11	
	1001213835	1	SENSOR, TILT 2.4° / DETECTEUR DE DEVERS 2.4°	
	4000008	1	SENSOR, PROXIMITY ASSEMBLY / FAISCEAU DETECTEUR DE PROXIMITE	
	1001232667	1	SENSOR SKYLINE ASSEMBLY / FAISCEAU CAPTEUR SKYLINE	
	260327	2	NO/NC SWITCH TELEMECANIQUE / CAPTEUR NO/NF TELEMECANIQUE	
	PC0468	1	HARNESS, LOAD SENSING SWITCH / FAISCEAU CAPTEUR DE SURCHARGE	
	4360505	1	SWITCH, ROTARY ANGLE SENSOR / CAPTEUR D'ANGLE	
	130064	4	D8 FAST-LEAD THREAD SCREW / VIS D8 PAS RAPIDE TETE LARGE	
	1001109503	1	MULTIDISPLAY INDICATOR / AFFICHEUR MULTIFONCTION	
	4360469	1	3 POSITIONS KEY SELECTOR / SELECTEUR A CLE 3 POSITIONS	
	1600458	1	JOYSTICK / JOYSTICK	
	1001155354	1	THUMB JOYSTICK / MINI JOYSTICK	
	1001109239	1	PC BOARD PLATFORM MODULE / CARTE BOITIER HAUT PROGRAMMEE	
	1001241322	2	CONTROLLER, ZAPI COMBI AC0 / VARIATEUR COMBI-ACO	
	952099	6	COIL 24VDC_3012599 / BOBINE 24VDC_3012599	

**SECTION 11 - RECOMMENDED PARTS LIST / LISTE DE PIÈCES
RECOMMANDÉES**

ITEM	PART NUMBER	QTY	DESCRIPTION	REV
	952101	1	COIL 24VADC_3110057 / BOBINE 24VADC_3110057	

SECTION 12 - SPECIAL OPTIONS / OPTIONS SPECIALES

SECTION 12 - SPECIAL OPTIONS / OPTIONS SPECIALES

FIGURE 12-1. SPECIAL OPTIONS / OPTIONS SPECIALES

ITEM	PART NUMBER	QTY	DESCRIPTION	REV
		Ref	Note: This list is to accommodate machines ordered with special equipment. Options may not be applicable to all models. For more specific parts information contact JLG Parts Department. / Remarque: Cette liste fourni les info complémentaires pour les Machines commandées avec des équipements spéciaux. Ces Options ne sont pas applicables à tous les modèles. Pour des informations plus spécifiques sur les pièces, contacter le service pièces JLG.	
		Ref	MISCELLANEOUS SPECIAL OPTIONS / OPTIONS SPECIALES DIVERSES	
		Ref	ClearSky Telematic Installation (Factory Installed) / Installation ClearSky (Telematic)-(installé en usine)	
	1001252510	Ref	ClearSky Installation - Canbus Connection (ANSI, CSA and JPN Specs) / Installation ClearSky, Connection Canbus (ANSI, CSA et JPN Specs)	
	1001252515	Ref	ClearSky Installation - Canbus Connection (ANSI Export and CE Specs) / Installation ClearSky, Connection Canbus (ANSI Export et CE Specs)	
	1001254156	Ref	ClearSky Installation - Canbus Connection (Australian Specs) / Installation ClearSky, Connection Canbus (Australian Specs)	
	1001229695	Ref	ClearSky decal Installation (Factory Installed) / Installation Autocollant Skyline (Installé en usine)	
	1001276610	Ref	CLEARSKY GT1030 Installation / Installation CLEARSKY GT1030	
	1001227877	Ref	Trackunit (Telematics) Installation (Factory Installed) - (CE Specs) / Installation Trackunit (Telematic)-(installé en usine)	
	1001214032	Ref	Install,decal,EAC (Russia,CIS) / Installation autocollant EAC (Russie, CIS)	
	1001223690	Ref	Possible positions for Custommer decals / Positions possibles des autocollants Client	
		Ref	CLEARSKY TELEMATIC KITS / KITS CLEARSKY TELEMATIC	
	1001265362	Ref	KIT, CLEARSKY CAN (N.A.) / KIT, CLEARSKY CAN (N.A.)	
	1001253875	Ref	KIT, CLEARSKY CAN (C.E.) / KIT CLEARSKY CAN (C.E.)	
	1001254190	Ref	KIT, CLEARSKY CAN (AUS) / KIT CLEARSKY CAN (AUS)	
	1001276923	Ref	KIT,CLEARSKY GT1030 / KIT CLEARSKY GT1030	
	1001251483	Ref	KIT,ACCESS CONTROL / KIT DE CONTROLE D'ACCES	
		Ref	SKYLINE KITS SKYLINE / KITS SKYLINE	
	1001270926	Ref	KIT SKYLINE / KIT SKYLINE	
	1001278130	Ref	KIT SKYLINE BEACON / KIT FEU SKYLINE	
		Ref	Tools for Service / Outils pour entretien et dépannage	
	2901443	Ref	Analyzer Kit / Kit Analyseur	
	1001249695	Ref	Analyzer and Cable Kit / Analyseur et kit cables	
	8896941	Ref	Wire Stripper / Pince à dénuder	
	7002821	Ref	Wire Crimper (To install wire ends to wires) / Pince à sertir (pour installer des cosses sur des fils)	
	7002823	Ref	Pin/Socket Extractor - Universal (For Removal of Pins/Sockets from Connectors) / Extracteur de contacts Universel (pour retrait broches de connecteurs)	

SECTION 12 - SPECIAL OPTIONS / OPTIONS SPECIALES

ITEM	PART NUMBER	QTY	DESCRIPTION	REV
	4460467	Ref	Extractor - 16-18 Gauge (For Removal of Pin/Sockets from Deutsch Connectors) / Extracteur AWG16-18 (pour retrait broches de connecteurs Deutch)	
	4460510	Ref	Extractor - 12-14 Gauge (For Removal of Pin/Sockets from Deutsch Connectors) / Extracteur AWG12-14 (pour retrait broches de connecteurs Deutch)	
	7016654	Ref	Screwdriver, Magnetic / Tournevis Magnétique	

PART NUMBER INDEX

SECTION 12 - SPECIAL OPTIONS / OPTIONS SPECIALES

00000394, 109, 115, 117, 119	1001155328 57	1001223677 103	1001231801 104
000005.....29, 51, 62, 113, 117, 119	1001155354 57, 128	1001223678 103	1001232667 53, 128
000006.....49	1001155460 57	1001223679 103	1001233406 21
000007.....94	1001155462 57	1001223680 103	1001233657 119
000008..... 15, 55, 62, 73	1001157657 57	1001223681 100	1001233658 119
000010... 11, 47, 117, 123	1001181045 113, 117	1001223682 100	1001233659 119
000014 10, 25, 29, 49, 51, 53, 70, 91, 111	1001187631 29	1001223683 101	1001237382 70
000015.....25, 29, 62, 91	1001192401 84	1001223684 101	1001239552 31, 33
000016..... 62, 109, 121	1001200910 107	1001223685 101	1001239741 63
000017..... 15, 62, 123	1001208856 57	1001223686 101	1001239742 62
000018..... 10	1001208857 57	1001223687 101	1001241322 15, 128
000026..... 63, 73	1001209934 55	1001223688 102	1001241965 53
000030..... 63	1001210910 10	1001223689 16	1001245202 15, 21, 86
000050..... 94	1001210948 29	1001223690 132	1001245244 102, 103
000051..... 62	1001211321 73	1001223713 73	1001246577 21
000059..... 70	1001211358 16	1001223810 29, 33	1001246578 21
000067.. 10, 94, 109, 119, 123	1001211404 38	1001223811 33	1001248510 62
000069..... 123	1001211405 10	1001223812 33, 128	1001248511 62
000077..... 15, 63	1001211406 29	1001223845 100	1001248513 62
000085..... 107, 113, 119	1001211408 62	1001223846 100	1001248814 10
000088..... 51	1001211409 70	1001223847 101	1001248815 10
000089..... 117, 119	1001211410 25	1001223848 101	1001249695 132
000090..... 49, 51, 119	1001211411 102	1001223849 101	1001251483 132
0140011 57	1001211412 100	1001223850 101	1001252510 132
0630580 16	1001211413 83	1001223851 101	1001252515 132
0641406 55	1001211414 91	1001223852 102	1001253875 132
100004 62	1001211415 91	1001223853 100, 101	1001254156 132
100007 25	1001211416 121	1001223854 100, 101, 102	1001254190 132
100009 15	1001211417 26	1001223855 101	1001254472 53
100012 73	1001211418 100	1001223856 101	1001254473 53
100013..... 15, 25, 41, 43	1001211419 100	1001223857 101	1001256013 57
100016 25	1001211420 47	1001223863 100, 101, 102	1001257866 107
100021 11	1001213033 91	1001223864 101, 102	1001258232 62
100027 10, 62, 70	1001213144 26	1001223864 101, 102	1001265362 132
100033 26	1001213145 26	1001223892 25	1001266631 51
100038 25	1001213632 16	1001223897 73	1001266724 49, 51
100049 70	1001213729 83	1001223898 73	1001266736 49
100053 15	1001213835 .. 16, 86, 128	1001223933 101	1001266810 49
100054..... 47, 49, 51	1001213899 83, 89	1001223934 101	1001266811 51
100063 38	1001213902 89	1001223935 101	1001266812 53
100098 16	1001213903 89	1001223936 101	1001266813 51
100102 15	1001213904 89	1001223937 101	1001266902 57, 128
100103..... 15, 25	1001213905 89	1001223938 102	1001266921 55, 57
100104 16	1001213970 83	1001224025 104	1001266923 57
1001102189 19	1001213985 91	1001224477 119	1001266925 57
1001102349 19	1001213986 91	1001225133 79	1001267022 51
1001102351 19	1001214032 132	1001225157 79	1001267235 84
1001102353 19	1001214284 100	1001225159 79	1001267261 107
1001102354 19	1001214285 100	1001225530 70	1001267266 107
1001109239 128	1001214286 100	1001225624 73	1001267296 29
1001109503... 31, 33, 128	1001214287 100	1001225702 38	1001267297 29
1001111752 25	1001214288 102, 103	1001226413 103, 104	1001267401 51
1001114466 16	1001214774 125	1001226415 104	1001267644 109
1001115919 57, 128	1001214777 125	1001227848 102, 103	1001267665 85
1001116692 85	1001215691 75	1001227877 132	1001267669 109
1001116694 85	1001216725 70	1001227893 119	1001267688 38
1001117172 109	1001217094 102	1001227894 25	1001267689 15
1001117177 57	1001219323 102	1001228600 100	1001267690 38
1001119619 85	1001220619 38	1001228601 100	1001267748 100
1001126009 85	1001220620 38	1001228973 100	1001267749 100
1001152692 57	1001222935 73, 75	1001229695 132	1001267750 100
1001154560 57	1001222936 70, 79	1001229970 119	1001267751 100
	1001222937 73	1001229971 119	1001270926 132
	1001223601 73	1001229972 119	1001271848 51
	1001223605 29	1001229973 119	1001271849 51
	1001223609 25	1001230297 109, 128	1001272230 38

SECTION 12 - SPECIAL OPTIONS / OPTIONS SPECIALES

1001272231	15	1321293 .53, 62, 94, 109,	250090.....	115, 117	400037	62, 70
1001272232	38	115, 117, 123	250091.....	84, 113, 117	400046	62
1001275523	53	140009	250135.....	113, 117	400047	62
1001276610	132	25, 38	250172.....	123	400048	49, 51
1001276683	47	140014	250211.....	91	400057	10
1001276923	132	140024	250213.....	91	400077	25, 123
1001277965	47	150002	250227.....	83	400087	119
1001278130	132	150004	250230.....	86	400092	62
1001278484	103, 104	150007	260006.....	123	400096	62
1001278485	103, 104	150011	260007.....	123	400097	25
100156	73	150019	260029.....	113	4031516	53
1060688	91	150058	260077.....	29	4060700	115
1060689	91	150059	260079.....	29, 128	4240147	16
110001 10, 107, 113, 119		150061	260144.....	123	4340871	57
110002 10, 11, 62, 94,		1580012	260146.....	123	4360469	31, 33, 128
109, 115, 117, 119		160010	260187.....	113	4360505	85, 94, 128
110003 10, 15, 41, 43, 49,		160018	260213.....	117	4360562	57, 128
51, 53, 57, 62, 70, 73,		160031	260214.....	113	4420051	102
109, 111, 113, 117,		160033	260240.....	31, 33	4460071	109, 115
119, 121		1600458	260243.....	31, 33	4460346	115
110004 10, 25, 38, 49		170008	260258.....	117	4460464 ...	83, 84, 85, 86
110005	16	1701499	260274.....	86	4460465 ..	83, 84, 85, 86,
110008	15	1703632	260275.....	85	119	
110009	38	1703785	260276.....	115	4460467	133
110010	38	1703811	260321.....	85	4460510	133
110015	70	1703814	260323.....	86, 128	4460536	84, 85, 86
110017	25	1704016	260326.....	86	4460539	83, 84, 119
110019	38	1704023	260327.....	85, 128	4460871	83
110020	38	1704031	260329.....	86	4460873	83
110022	49, 51	1704277	260339.....	119	4460884	84, 85, 119
110026	10, 25	1704885	260341.....	119	4460891	83, 84
110040	10	1705781	270002.....	113, 115, 117	4460894	83, 86
110041	62, 70	1705803	270031.....	123	4460897	83, 85, 86
110042	70	1706493	270059.....	84	4460899	84, 85
120002 ... 47, 62, 94, 109,		1706740	2780266.....	15, 19	4460917	85, 86
115, 117, 119		1706764	280023.....	49	4460928	83, 84
120003	47	1706898	2860030.....	31, 33, 128	4460930	83
120004	10, 55, 70	180003	2901443.....	132	4460931	83
120006	38	180009	300001.....	15	4460932	84, 85
120009 10, 11, 16, 25, 29,		190027	300025.....	73, 75	4460933	83
49, 51, 62, 70, 91, 109,		190072	300034.....	75	4460943	84
111, 113, 117, 121, 125		190074	300037.....	73	4460944	83
120010	10, 38, 70	190077	300040.....	75	4460970	84
120011	73	210011	300044.....	73	4461076	85
120016	73	210012	300047.....	75	4461077	84, 85
120017	38	210018	300061.....	70, 79	4740468	19
120024 ... 49, 51, 94, 107,		210019	300101.....	75	4751400	55
113, 119		210021	300161.....	121	4761400	55
120030	73, 119	210052	300172.....	25	500021	25
120033	29	210059	310091.....	75	510094	91
120036	38	210066	310103.....	75, 128	520115	70, 77
120043	123	230016	310109.....	73	7000084	57
120054	11, 15, 25	2400060	320067.....	25	7000682	57
120055	16, 26	240056	3300423.....	19	7002821	132
120056	10, 94	240057	3311601.....	53	7002823	132
120057	10	240058	3450406.....	19	7016654	133
120058	113	240060	3575796.....	57	7027365	57
120059	115, 117	240076	3740150.....	29, 128	7027367	57, 128
120060	29, 113, 117	240093	3820019.....	57	7027765	57
130007	62	250001	3900357.....	57	7027766	57
130021	10	250026	3900358.....	57	8229242	84
130029	47	250027	3900359.....	57	8896941	132
130059	31, 33	250031	4000007.....	85, 119	8990147	49, 51
130062	10, 29, 57	250051	4000008.....	85, 94, 128	920042	62
130064	10, 128	250060	400010.....	62	920045	62
130066	70	250071	400012.....	62, 70	920046	62
		250084	400018.....	62, 121	920052	62
		250089				

SECTION 12 - SPECIAL OPTIONS / OPTIONS SPECIALES

920073.....62	AU2149..... 103, 104	PC0619..... 119	ST3219.....63
930109.....25	AU2150..... 103, 104	SA0001..... 15	ST3226.....94
930134..... 75, 128	AU2152..... 104	SA0002..... 15	ST3227.....94
930135..... 75	AU2154..... 104	SA0003..... 25	ST3231..... 70
930136..... 75	AU2155..... 104	SA0004..... 25	ST3235..... 11
930138..... 75	AU2207..... 31	SA0009..... 16	ST3246..... 25
951034..... 75	AU2215..... 70, 102, 104	SA0012..... 94	ST3312..... 57
951036..... 21	AU2228..... 29	SA0020..... 55	ST3318..... 73
951037..... 21	AU2229..... 102, 103	SA0021..... 11	ST3332..... 15
951038..... 21	DF0269..... 67	SA0026..... 113	ST3333..... 38
951039..... 21	DF0710..... 67	SA0027..... 113	ST3598..... 11
951040..... 21	DF0975..... 67	SA0028..... 117	ST3696..... 11
951041..... 21	DF0976..... 67	SA0037..... 115	ST3697..... 11
952094..... 75	DF0977..... 67	SA0144..... 16	ST3700..... 25
952095..... 75	DF0978..... 121	SD0345..... 94	ST3703..... 70
952096..... 75	DL0818..... 38	SD0452..... 43	ST3774..... 29
952097..... 75	DL0819..... 15	SD0453..... 41	ST3775..... 31, 33
952098..... 75	DL0824..... 38	SD0464..... 94	ST3776..... 91
952099..... 75, 77, 79, 128	DL0828..... 62	SE0730..... 38, 41	ST3778..... 91
952100..... 75	DL0837..... 25	SE0731..... 38, 43	ST3780..... 70
952101..... 75, 129	DL0838..... 25	SE1139..... 94	ST3781..... 63
952102..... 77	DL0911..... 70	SE1140..... 94	ST3790..... 10
952104..... 77	DL0918..... 47	SE1141..... 94	ST3841..... 11
952106..... 77	DL0921..... 16	SE1200..... 29, 31	ST3856..... 10
952107..... 77, 79	DL0923..... 38	SE1202..... 31, 128	US0026..... 38
952108..... 75	DL0924..... 38	SE1204..... 70	US0134..... 15
960097..... 38	DL0934..... 26	SE1214..... 38	US0190..... 15, 25
960098..... 38	DL0935..... 38	ST0099..... 38	US0204..... 94
960099..... 15	DL0936..... 38	ST0736..... 49	US0208..... 94
970065..... 75	DL0937..... 10	ST0763..... 49	US0216..... 15
AU0149..... 102, 103	FX158-014..... 123	ST0838..... 62	US0236..... 49, 51
AU1423..... 102, 103	KT0143..... 67	ST1326..... 62	US0277..... 70
AU1716..... 113, 115, 117	OP509..... 111	ST1969..... 121	US0375..... 43
AU1825..... 100	OP521..... 123	ST2475..... 25	US0377..... 41
AU2097..... 102, 103	PA1138..... 100	ST2741..... 49, 51	US0475..... 41
AU2098..... 102, 103	PC0465..... 31, 33	ST3022..... 111	US0479..... 43
AU2099..... 102, 103	PC0466..... 85, 111	ST3114..... 10	US0481..... 39
AU2102..... 100	PC0468..... 85, 94, 128	ST3115..... 10	US0523..... 15
AU2103..... 102	PC0469..... 85	ST3155..... 31, 33	US0524..... 25
AU2105..... 102, 103	PC0470..... 86, 94	ST3158..... 15	US0527..... 25
AU2107..... 102	PC0479..... 89	ST3164..... 25	US0528..... 15
AU2108..... 102	PC0480..... 89	ST3169..... 25	US0529..... 15
AU2109..... 100	PC0482..... 89	ST3170..... 10	US0530..... 15
AU2117..... 103	PC0483..... 89	ST3171..... 10	US0531..... 15, 47
AU2118..... 103	PC0484..... 89	ST3172..... 10	US0532..... 16
AU2119..... 103	PC0488..... 84	ST3173..... 10	US0537..... 39
AU2140..... 104	PC0489..... 84	ST3174..... 10	US0538..... 39
AU2143..... 104	PC0491..... 29, 86	ST3175..... 10	US0603..... 47
AU2144..... 104	PC0528..... 123	ST3176..... 10	
AU2145..... 104	PC0534..... 11, 86	ST3177..... 10	
AU2147..... 103, 104	PC0618..... 119	ST3212..... 117	



31210401



An Oshkosh Corporation Company

Corporate Office
JLG Industries, Inc.
1 JLG Drive
McConnellsburg, PA 17233-9533 USA
☎ **(717) 485-5161 (Corporate)**
☎ **(877) 554-5438 (Customer Support)**
☎ **(717) 485-6417**

Visit our website for JLG Worldwide Locations.
www.jlg.com