



MODELS TOUCAN 1100



SPARE PARTS MANUAL MANUEL DE PIÈCES DÉTACHÉES

U.S.A.
JLG INDUSTRIES, INC
1 JLG Drive
McConnellsburg
PA 17233-9533
Tél : (717) 485-5161
Fax : (717) 485-6417

C.E.
JLG Industries,
Kilmartin Place,
Tannochside Park
Uddingston, Scotland G71 5PH
Tel : +44(0)1698 811005
Fax : +44(0)1698 811055

AUSTRALIA
JLG INDUSTRIE
P.O Box 972
11 Bolwarra Road
Port MacQuarie N.S.W. 44
Tel : 1 (065) 811111
Fax : 1 (065) 810122

FRANCE
Delta Manlift SAS
Z.I. «Guillaume mon amy»
BP 20 - 47400 TONNEINS
France
Tel : +33 553 84 85 11
Fax : +33 553 79 06 87

Updated : 01-2005

MA0132-05
English/French



DISTRIBUTOR STAMP / CACHET DISTRIBUTEUR

MACHINE SERIAL NUMBER :
NUMERO DE SERIE MACHINE :

TOUCAN 1100A N° _____

TOUCAN 1100C N° _____



Edition 01-2005
MA0132-05

SPARE PARTS

TO ORDER PARTS

IT IS ESSENTIAL TO SUPPLY THE FOLLOWING INFORMATION ON PARTS ORDERS SO THAT YOUR ORDER CAN BE PROPERLY EXPEDITED.

1. Give model and serial number of your machine. This information is found on the serial number plate mounted on the platform.
2. Give complete information on the parts requested including the part number, description, and quantity.
3. Give the specific major unit for which the item is required, such as : frame, mast, cylinder, platform, control box, etc.
4. Give complete "ship-to" address and specify the exact method of shipment wanted.
5. Specify the urgency of the parts order by designating the priority (emergency or stock).

NOTE

When placing telephone order, please record with whom you spoke and date, so that follow-up telephone conversations are processed without confusion.

PIECES DETACHEES

POUR PASSER COMMANDE

AFIN QUE VOTRE COMMANDE SOIT CORRECTEMENT TRAITEE, IL EST NECESSAIRE DE FOURNIR LES INFORMATIONS SUIVANTES SUR LE BON DE COMMANDE.

1. Noter le modèle et le numéro de série de votre machine. Ces informations se trouvent sur la plaque constructeur qui est fixée sur le panier.
2. Noter entièrement les renseignements sur les articles en commande : référence de la pièce, description et quantité.
3. Indiquer l'unité principale pour laquelle la pièce est commandée : châssis, mât, vérin, plate-forme, boîtier de commande, etc...
4. Noter l'adresse complète du destinataire et indiquer le mode d'expédition souhaité.
5. Spécifier l'urgence des pièces commandées en indiquant leur priorité (urgence ou stock).

NOTE

Si vous passez une commande téléphonique, noter le nom de votre interlocuteur et la date afin que le suivi de votre entretien se fasse sans confusion.

TOUCAN 1100



CHARGER
CHARGEUR
SECTION 4

MAST 1
MAT 1
SECTION 10

MAST CYLINDER
VERIN DE MAT
SECTION 6

MAST 2-3-4-5
MATS 2-3-4-5
SECTION 7

POWER BRIDGE
CHAINES PORTE CABLES
SECTION 5

BATTERY PACK
BATTERIE
ANNEXE F

LOWER CONTROL BOX
BOITIER ELECTRIQUE BAS
SECTION 3

COUNTERWEIGHT
CONTREPOIDS
SECTION 2

CENTRALE/PUMP-MOTOR
RESERVOIR/OIL TANK
DRIVE MANIFOLD BLOC
BLOC DE TRANSLATION
SECTION 9

BRAKE CYLINDER
VERINS FREIN
SECTION 9

ALARM
ALARME
SECTION 3

SWING MOTOR
MOTEUR D'ORIENTATION
SECTION 10

UPPER CONTROL VALVE
DISTRIBUTEUR HAUT
SECTION 6

UPPER CONTROL BOX
BOITIER ELECTRIQUE HAUT
SECTION 3

JIB
BRAS
SECTION 11

FLAP
PORTILLON
ANNEXE H

FOOT SWITCH
PEDALE
SECTION 3

PLATFORM
PANIER
ANNEXE H

JIB CYLINDER
VERIN DE BRAS
SECTION 6

COVERS
CAPOTS
SECTION 1

FRAME
CHASSIS
SECTION 9

TILT SENSOR
DETECTEUR DE DEVERS
SECTION 3

STEERING
DIRECTION
SECTION 9

WHEELS
ROUES
SECTION 9

HAND PUMP
POMPE A MAIN
SECTION 6

LOWER VALVE
DISTRIBUTEUR BAS
SECTION 6

TABLE OF CONTENTS		TABLE DES MATIERES	
COVERS INSTALL	1	INSTALLATION CAPOTS	1
COUNTERWEIGHT INSTALL	2	INSTALLATION CONTREPOIDS	2
ELECTRICAL INSTALL	3	INSTALLATION ELECTRIQUE	3
UPPER CONTROL BOX ASSEMBLY	3-1	ASSEMBLAGE BOITIER HAUT	3-1
LOWER CONTROL BOX ASSEMBLY	3-2	ASSEMBLAGE BOITIER BAS	3-2
CHARGER INSTALL	4	INSTALLATION CHARGEUR	4
CHANNEL AND POWER BRIDGE INSTALL	5	INSTALLATION CHAINES PORTE CABLES	5
HYDRAULIC INSTALL	6	INSTALLATION HYDRAULIQUE	6
MAST CYLINDER ASSEMBLY	6-1	ASSEMBLAGE VERIN DE MAT	6-1
LOWER VALVE ASSEMBLY	6-2	ASSEMBLAGE DISTRIBUTEUR BAS	6-2
BULKHEAD ASSEMBLY	6-3	ASSEMBLAGE TRAVERSEE DE CLOISON	6-3
JIB CYLINDER ASSEMBLY	6-4	ASSEMBLAGE VERIN DE BRAS	6-4
JIB FLOW CONTROL ASSEMBLY	6-5	ASSEMBLAGE ETRANGLEUR BRAS	6-5
HAND PUMP ASSEMBLY	6-6	ASSEMBLAGE POMPE A MAIN	6-6
HYDRAULIC SCHEMATIC	6-7	SCHEMA HYDRAULIQUE	6-7
MAST INSTALL	7	INSTALLATION DU MAT	7
MAST 2 ASSEMBLY	7-1	ASSEMBLAGE MAT 2	7-1
MAST 3 ASSEMBLY	7-2	ASSEMBLAGE MAT 3	7-2
MAST 4 ASSEMBLY	7-3	ASSEMBLAGE MAT 4	7-3
MAST 5 ASSEMBLY	7-4	ASSEMBLAGE MAT 5	7-4
ROLLER ASSEMBLY	7-4-1	ASSEMBLAGE GALET DE GUIDAGE	7-4-1
PULLEY ASSEMBLY	7-4-2	ASSEMBLAGE SUPPORT POULIES	7-4-2
PULLEY ASSEMBLY	7-4-3	ASSEMBLAGE SUPPORT POULIES	7-4-3
PULLEY ASSEMBLY	7-4-4	ASSEMBLAGE SUPPORT POULIES	7-4-4
TURNTABLE INSTALL	8	INSTALLATION TOURELLE	8
FRAME INSTALL	9	INSTALLATION CHASSIS	9
STEERING INSTALL	9-1	INSTALLATION DE LA DIRECTION	9-1
HYDRAULIC RESERVOIR INSTALL	9-2	INSTALLATION DU RESERVOIR	9-2
DRIVE MANIFOLD ASSEMBLY	9-2-1	ASSEMBLAGE BLOC TRANSLATION	9-2-1
DRIVE MANIFOLD	9-2-1-1	BLOC FORE DE TRANSLATION	9-2-1-1
2 SPEED MANIFOLD	9-2-1-1-1	BLOC 2 VITESSES	9-2-1-1-1
3rd SPEED MANIFOLD	9-2-1-1-2	BLOC 3° VITESSE	9-2-1-1-2
HYDRAULIC RESERVOIR ASSEMBLY	9-2-2	ASSEMBLAGE DU RESERVOIR	9-2-2
HYDRAULIC DRIVE MOTORS INSTALL	9-3	INSTALLATION DES MOTEURS DE ROUE	9-3
BRAKE CYLINDER INSTALL	9-4	INSTALLATION DES VERIN FREINS	9-4
PUMP/MOTOR INSTALL	9-5	INSTALLATION DE LA CENTRALE	9-5
5.5cc/rev POWER UNIT	9-5-1	CENTRALE 5.5cm ³ /t	9-5-1
5.5 cc/rev PUMP	9-5-1-1	POMPE 5.5 cm ³ /t	9-5-1-1
MAST 1 ASSEMBLY	10	ASSEMBLAGE MAT 1	10
SWING DRIVE ASSEMBLY	10-1	ASSEMBLAGE REDUCT. D'ORIENTATION	10-1
DOUBLE RELIEF VALVE MANIFOLD	10-2	BLOC LIMITEUR DOUBLE	10-2
JIB INSTALL	11	INSTALLATION BRAS	11
APPENDIX	16	ANNEXES	16
OPTIONS	17	OPTIONS	17
CROSS REFERENCE CHART	LAST PAGE	TABLEAU DE CORRESPONDANCE	DERNIERE PAGE

SPARE PARTS
PIECES DETACHEES

SECTION 1.

COVERS INSTALL.
INSTALLATION CAPOTS.



COVERS INSTALL INSTALLATION CAPOTS

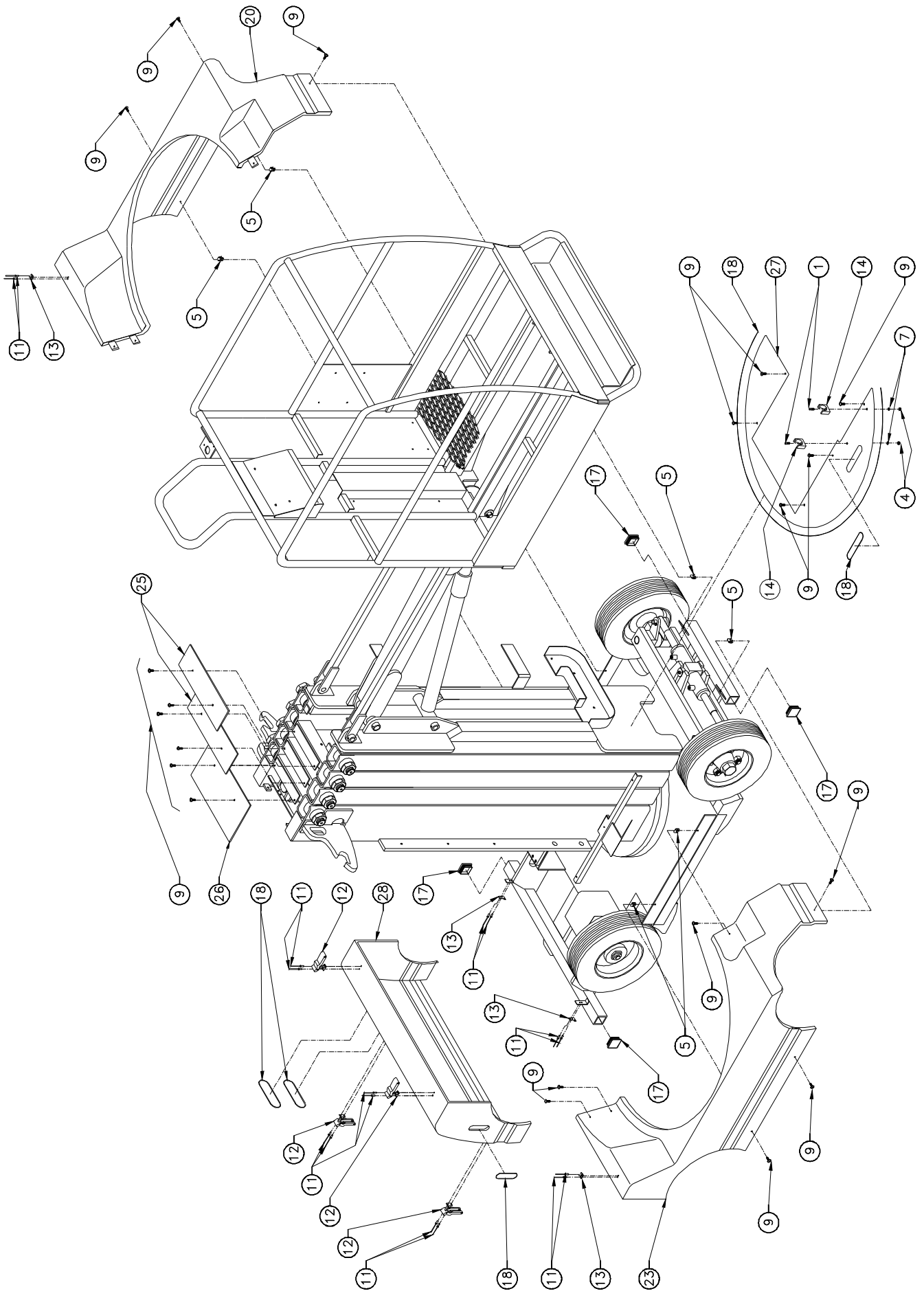

COVERS INSTALL INSTALLATION CAPOTS

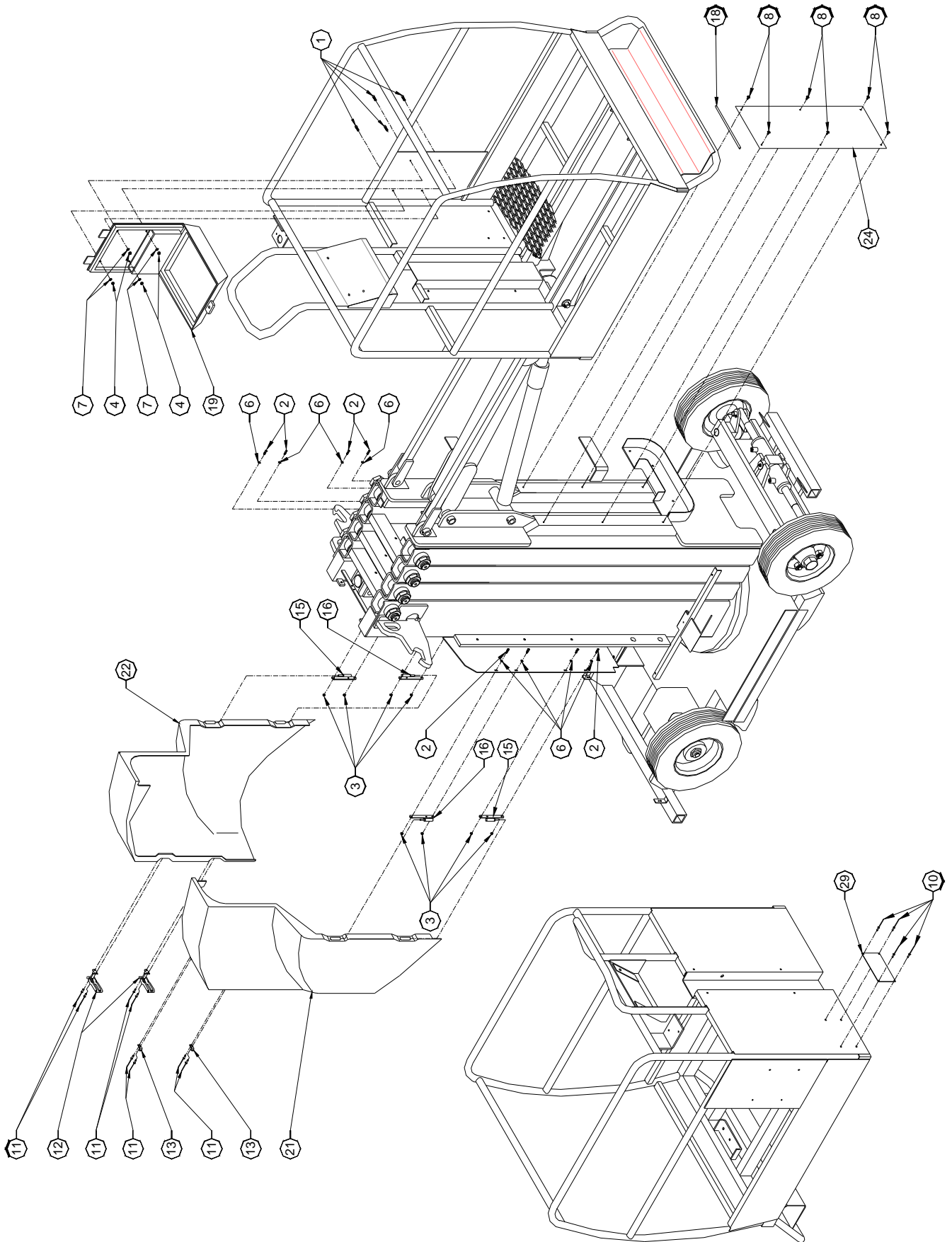

DATE : 25/08/99

COVERS INSTAL

MONTAGE N°/

ASSY NO : SP0241 REV : A

INSTALLATION CAPOTS

1/1

DET NO.	REF./PART NUMBER	VOIR/ SEE VIEW	DESCRIPTION		R E V	Qté/ Qty Req.
1	000005		M06x20 8.8 SOCKET HEAD MACH SCREW	VIS CHC M06x20 8.8 BI FT		6
2	000067		M05x12 8.8 SOCKET HEAD MACH SCREW	VIS CHC M05x12 8.8 BI FT		8
3	110002		M05 GR. 8.8 LOCK NUT	ECROU FREIN M5 8.8 BI		8
4	110003		M06 GR. 8.8 LOCK NUT	ECROU FREIN M6 8.8 BI		6
5	110027		M06 CAGE HEX NUT	ECROU CAGE M06		6
6	120002		M05 WASHER	RONDELLE M05 BI		8
7	120009		dD 06x14 LOCK WASHER	RONDELLE CONTACT dD 06x14 BI		6
8	130007		Ø4.8x13 LG SHEET METAL SCREW	VIS AUTOTARAUDEUSE Ø4,8-13		6
9	130021		M06x20 8.8 ROUND HEAD MACH SCREW	VIS BOMBEE ULF M06x20 8.8 BI FT		20
10	180002		Ø4x10 POP RIVET	RIVET POP Ø4x10		4
11	180005		Ø4x16 POP RIVET	RIVET POP Ø4x16		24
12	190018		C 7-10 RUBBER LATCH	GRENOUILLERE C 7-10		6
13	190019		C 7-10 LATCH LOCKING TAB	RECEPTACLE C 7-10		6
14	190027		Ø22 CLIP	CLIP Ø22		2
15	190033		MALE HINGE	PAUMELLE MALE		2
16	190035		MALE HINGE	PAUMELLE MALE		2
17	400004		SHOCK ABSORBER CAP	BOUCHON PARE CHOC		4
18	400032		EDGE GUARD (quantity indicated in meter)	PROFIL A ARMATURE (quantité en mètre)		5
19	7348000653		MANUAL BOX	BOITE PORTE DOCUMENTS		1
20	SD0053		RIGHT SIDE COVER	COQUE DROITE		1
21	SD0313		LEFT DOOR	PORTE GAUCHE		1
22	SD0314		RIGHT DOOR	PORTE DROITE		1
23	ST0129		LEFT SIDE COVER	COQUE GAUCHE		1
24	ST0462		HOSE GUARD COVER / MAST 5	TOLE GOULOTTE MAT 5	A	1
25	ST1004		MAST TOP COVER	COUVRE MAT		2
26	ST1005		MAST TOP COVER	COUVRE MAT		1
27	ST1287		TOP COVER	TOLE COUVRE JOINT		1
28	ST1391		FRONT COVER	COQUE AVANT		1
29		APPENDIX G	PLAQUE CONSTRUCTEUR	MANUFACTURER'S NAME PLATE		1

SPARE PARTS
PIECES DETACHEES

SECTION 2.

COUNTERWEIGHT INSTALL.
INSTALLATION CONTREPOIDS.



COUNTERWEIGHT INSTALL INSTALLATION CONTREPOIDS

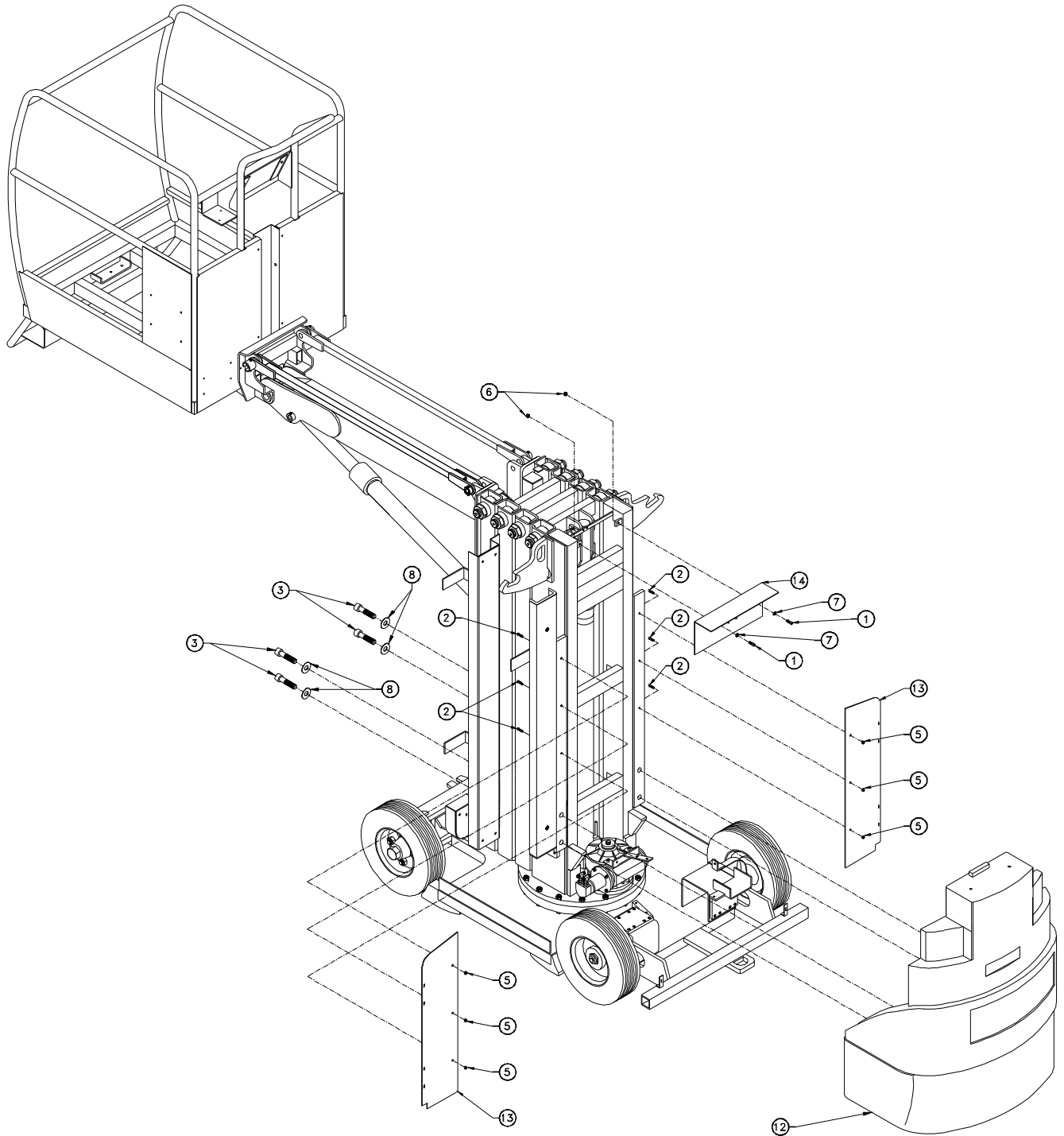

SPARE PARTS
PIECES DETACHEES

SECTION 3.

ELECTRICAL INSTALL.
INSTALLATION ELECTRIQUE.



ELECTRICAL INSTALL INSTALLATION ELECTRIQUE

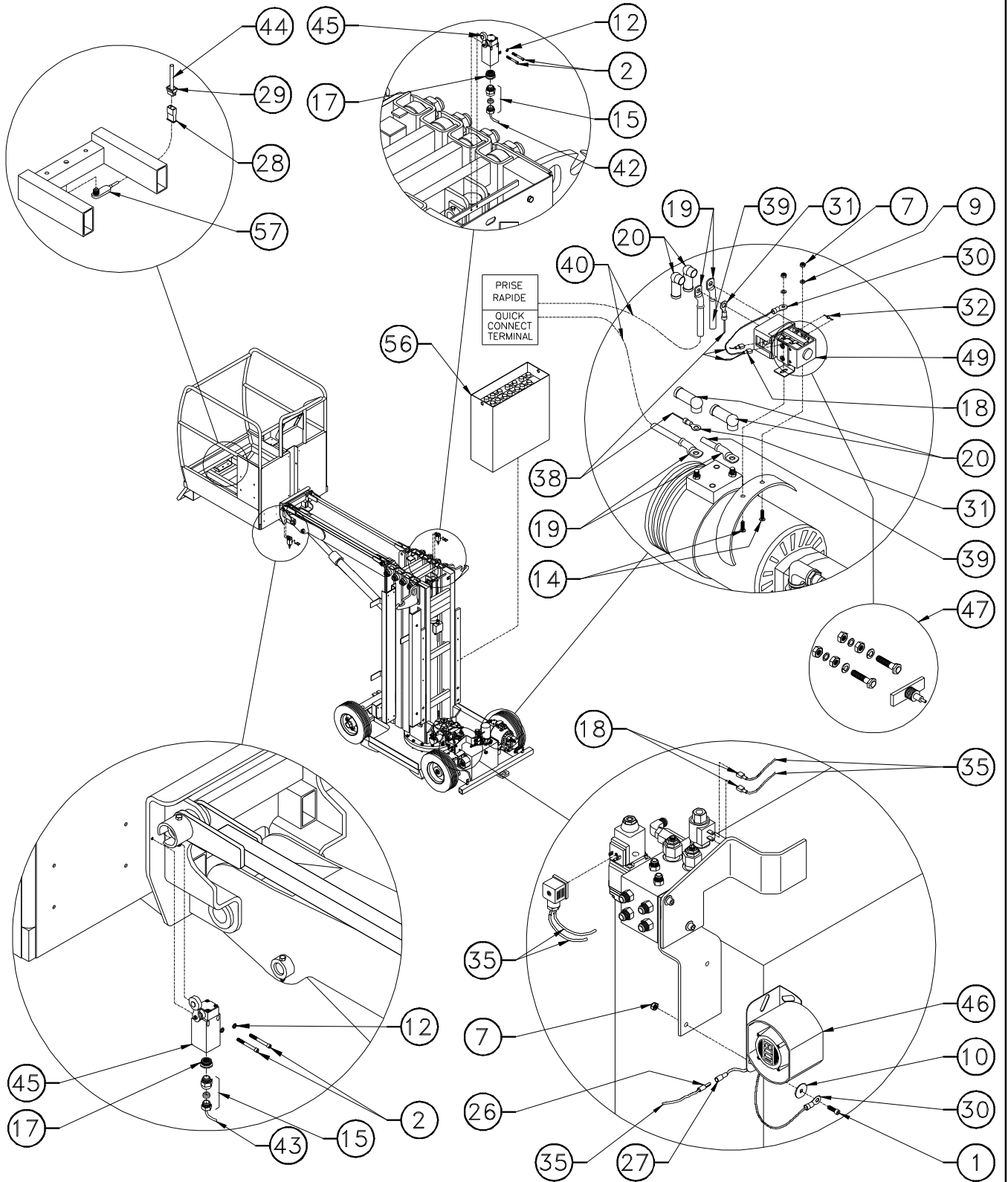

ELECTRICAL INSTALL INSTALLATION ELECTRIQUE

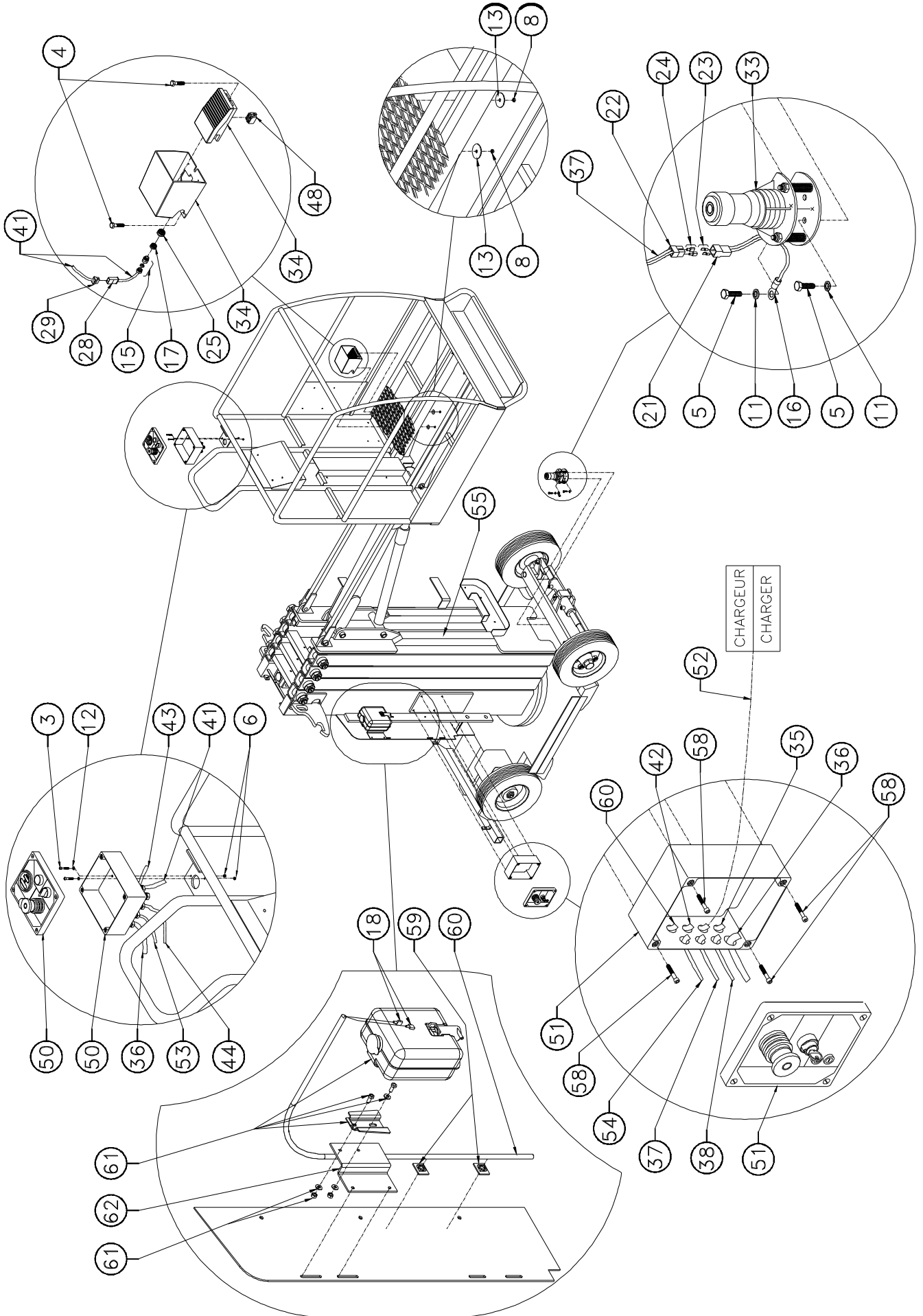

DATE : 22/03/04

ELECTRICAL INSTALL

MONTAGE N°/

ASSY NO : SP0228 REV : B

INSTALLATION ELECTRIQUE

1/2

DET NO.	REF./PART NUMBER	VOIR/ SEE VIEW	DESCRIPTION		RE V	Qté/ Qty Req.
1	000003		M05x16 8.8 SOCKET HEAD MACH SCREW	VIS CHC M05x16 8.8 BI FT		1
2	000004		M04x35 8.8 SOCK. HEAD MACH. SCREW	VIS CHC M04x35 8.8 BI FT		4
3	000020		M04x20 8.8 SOCKET HEAD MACH SCREW	VIS CHC M04x20 8.8 BI FT		2
4	100008		M08x30 8.8 HEX HEAD MACHINE SCREW	VIS H M08x30 8.8 BI FT		2
5	100027		M06x12 8.8 HEX HEAD MACHINE SCREW	VIS H M06x12 8.8 BI FT		2
6	110001		M04 GR. 8.8 LOCK NUT	ECROU FREIN M4 8.8 BI		2
7	110002		M05 GR. 8.8 LOCK NUT	ECROU FREIN M5 8.8 BI		3
8	110004		M08 GR. 8.8 LOCK NUT	ECROU FREIN M8 8.8 BI		2
9	120002		M05 WASHER	RONDELLE M05 BI		2
10	120004		dD 06x25 WASHER	RONDELLE dD 06x25x1.2 BI		1
11	120009		dD 06x14 LOCK WASHER	RONDELLE CONTACT dD 06x14 BI		2
12	120024		M04 LOCK WASHER	RONDELLE CONTACT M04 BI		6
13	120026		dD 08x40 WASHER	RONDELLE dD 08x40 BI		2
14	130010		M05x16 8.8 CROSS RECESSED PAN HEA	VIS POELIER M05x16 8.8 BI FT		2
15	210017		GLAND N°9	PRESSE ETOUPE N°9		3
16	250010		M08 EYELET TERMINAL 4-6mm ²	COSSE A ŒIL ISOLEE M8 - 4-6mm ²		1
17	250015		REDUCTION 13/9	REDUCTION 13/9		3
18	250027		BLUE RECEPTACLE TER. 6.3 - 1.5-2.5mm ²	COSSE FEM. 6.3 BLEUE 6.3 - 1.5-2.5mm ²	A	6
19	250030		Ø8 EYELET CRIMP TERMINAL 35 mm ²	COSSE A ŒIL Ø 8 - 35 mm ²		4
20	250031		TERMINAL CAP	CAPUCHON D'ETANCHEITE		4
21	250032		2 POSITIONS CAP HOUSING	CONNECTEUR FEMELLE 2 BROCHES		1
22	250033		2 POSITIONS PLUG HOUSING	CONNECTEUR MALE 2 BROCHES		1
23	250034		BLADE TERMINAL 6.3mm	COSSE PLATE MALE 6.3mm		2
24	250035		RECEPTACLE TERMINAL 6.3mm	COSSE PLATE FEMELLE 6.3mm		2
25	250047		16/13 REDUCTION	REDUCTION 16/13		1
26	250065		PIN TERMINAL Ø4	COSSE MALE Ø4		1
27	250070		INSULATED SOCKET TERMINAL Ø4	COSSE CYLINDRIQUE FEM. ISOLEE Ø4		1
28	250078		3 POSITIONS PLUG HOUSING	CONNECTEUR MALE 3 BROCHES		2
29	250079		3 POSITIONS CAP HOUSING	CONNECTEUR FEMELLE 3 BROCHES		2
30	250082		M05 EYELET TERMINAL 0.25-1mm ²	COSSE A ŒIL ISOLEE M5 - 0.25-1mm ²		2
31	250084		M08 EYELET TERMINAL 0.25-1mm ²	COSSE A ŒIL ISOLEE M8 - 0.25-1mm ²		2
32	260010		DIODE	DIODE		1
33	260270		2° TILT SENSOR	DETECTEUR DE DEVERS 2°	A	1
34	260103		FOOT SWITCH	PEDALE		1
35	270005		CABLE 7x1mm ² (quantity indicated in meter)	CABLE 7x1mm ² (qté indiquée en mètre)		4
36	270008		CABLE 12x1mm ² (quantity indicated in meter)	CABLE 12x1mm ² (qté indiquée en mètre)		12
37	270010		CABLE 2x1mm ² (quantity indicated in meter)	CABLE 2x1mm ² (qté indiquée en mètre)		5.5

DATE : 22/03/04

ELECTRICAL INSTALL

MONTAGE N°/

ASSY NO : SP0228 REV : B

INSTALLATION ELECTRIQUE

2/2

DET NO.	REF./PART NUMBER	VOIR/ SEE VIEW	DESCRIPTION		REVIEW	Qté/ Qty Req.
38	270011		CABLE 5x1mm ² (quantity indicated in meter)	CABLE 5x1mm ² (qté indiquée en mètre)		4
39	270021		WIRE 35mm ² (quantity indicated in meter)	CABLE 35mm ² (qté indiquée en mètre)		0.25
40	270021		WIRE 35mm ² (quantity indicated in meter)	CABLE 35mm ² (qté indiquée en mètre)		2x5.5
41	270022		CABLE 3x1mm ² (quantity indicated in meter)	CABLE 3x1mm ² (qté indiquée en mètre)		2
42	270011		CABLE 5x1mm ² (quantity indicated in meter)	CABLE 5x1mm ² (qté indiquée en mètre)		3
43	270011		CABLE 5x1mm ² (quantity indicated in meter)	CABLE 5x1mm ² (qté indiquée en mètre)		2.5
44	270022		CABLE 3x1mm ² (quantity indicated in meter)	CABLE 3x1mm ² (qté indiquée en mètre)		0.5
45	260030		2NC SWITCH	CAPTEUR 2NF		2
46	7025000801		MOTION ALARM (=260275)	ALARME DE MOUVEMENT (=260275)		1
47	910002		CONTACT KIT (included in SE1003)	KIT DE CONTACT (inclus dans SE1003)		1
48	910038		FOOT SW. CONTACT (included in 260103)	CONTACT PEDALE (inclus dans 260103)		1
49	SE1003		POWER RELAY	RELAIS DE PUISSANCE		1
50		SP0223	UPPER CONTROL BOX ASSEMBLY	ASSEMBLAGE BOITIER ELEC. HAUT		1
51		SP0224	LOWER CONTROL BOX ASSEMBLY	ASSEMBLAGE BOITIER ELEC. BAS		1
52		SECTION 4	CABLE 2x1 mm ²	CABLE 2x1 mm ²		x
53		APPENDIX B	CABLE 2x1mm ²	CABLE 2x1 mm ²		x
54		APPENDIX B	CABLE 2x1mm ²	CABLE 2x1 mm ²		x
55		APPENDIX B	CHAIN SWITCH ASSEMBLY	MONTAGE CAPTEURS DE CHAINES		1
56		APPENDIX F	BATTERY	BATTERIE		1
57		APPENDIX H	OVERLOAD SENSOR	DETECTEUR DE POSITION SENSIBLE		1
58	000067		M05x12 8.8 SOCKET HEAD MACH SCREW	VIS CHC M05x12 8.8 BI FT	B	4
59	220008		ADHESIVE BASE	EMBASE ADHESIVE	A	2
60	270010		CABLE 2x1mm ² (quantity indicated in meter)	CABLE 2x1mm ² (qté indiquée en mètre)	A	0.8
61	400058		DISTILLED WATER CAN KIT	KIT BIDON D'EAU DISTILLEE	A	1
62	ST1978		CAN SUPPORT	SUPPORT BIDON	A	1

UPPER CONTROL BOX ASSEMBLY ASSEMBLAGE BOITIER ELECTRIQUE HAUT

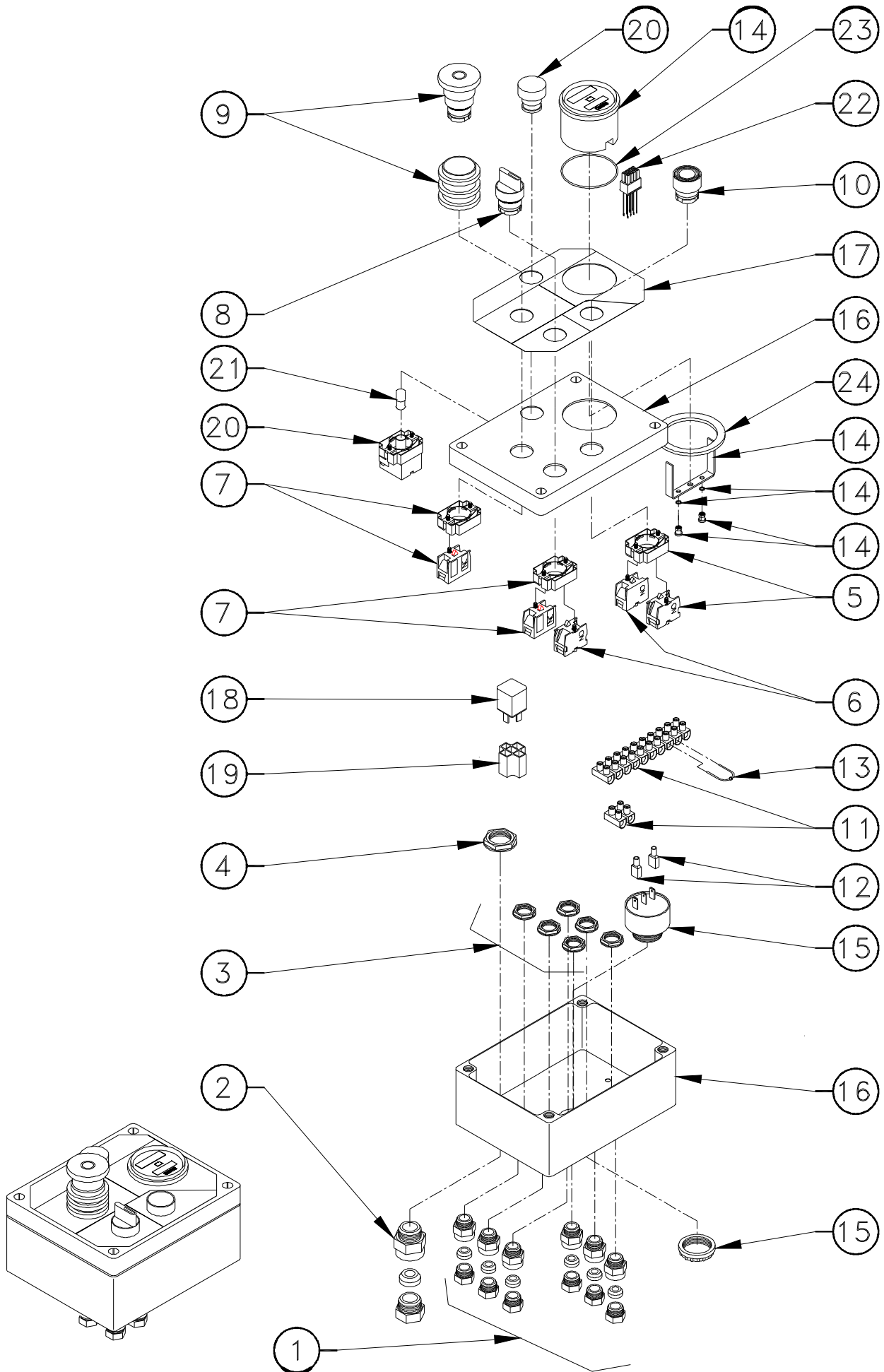

DATE : 22/03/04

UPPER CONTROL BOX ASSEMBLY

MONTAGE N°/

ASSY NO : SP0223 REV : B

ASSEMBLAGE BOITIER ELEC. HAUT

1/1

DET NO.	REF./PART NUMBER	VOIR/ SEE VIEW	DESCRIPTION		R E V	Qté/ Qty Req.
1	210017		GLAND N°9	PRESSE ETOUPE N°9		6
2	210019		GLAND N°13	PRESSE ETOUPE N°13		1
3	210009		GLAND N°9 NUT	ECROU DE PRESSE ETOUPE N°9		6
4	210011		GLAND N°13 NUT	ECROU DE PRESSE ETOUPE N°13		1
5	240004		CONTACT BLOCK HOLDER NO	EMBASE CONTACT NO		1
6	240006		NO CONTACT BLOCK	CONTACT NO		2
7	240013		NC CONTACT BLOCK HOLDER	EMBASE CONTACT NC		2
8	240014		3 POSITIONS SELECTOR	SELECTEUR 3 POSITIONS		1
9	240025		KNOB (EMERGENCY STOP SWITCH)	ARRET D'URGENCE		1
10	240026		PUSH BUTTON	BOUTON POUSSOIR		1
11	250020		TERMINAL BLOCK	BARRETTE DE CONNEXION		1
12	250027		BLUE RECEPTACLE TER. 6.3 - 1.5-2.5mm	COSSE FEM. 6.3 BLEUE 6.3 - 1.5-2.5mm ²		2
13	260010		DIODE	DIODE		1
14	260142		24V HOURMETRE BATTERY INDICATOR	INDICATEUR DE DECHARGE HORAMETRE		1
15	260045		BUZZER 24 V	BUZZER 24 V		1
16	SD0640		DRILLED ELECTRICAL BOX	BOITIER ELECTRIQUE PERCE	B	1
17	AU1869		UPPER CONTROL BOX DECAL	AUTOCOLLANT BOITIER HAUT	B	1
18	260019		1RT 24V RELAY	RELAIS 24 V 1RT		1
19	250036		24V RELAY CONNECTOR	CONNECTEUR DE RELAIS 24V		1
20	240022		LED	VOYANT		1
21	240024		BULBE 24 V	AMPOULE 24 V		1
22	260143		HOURMETRE INDICATOR CONNECTOR	CONNECTEUR HORAMETRE		1
23	ST2063		BUZZER SEAL	JOINT BUZZER		1
24	ST2064		BATTERY INDICATOR REINFORCEMENT	RENFORT INDICATEUR BATTERIE		1

LOWER CONTROL BOX ASSEMBLY ASSEMBLAGE BOITIER ELECTRIQUE BAS

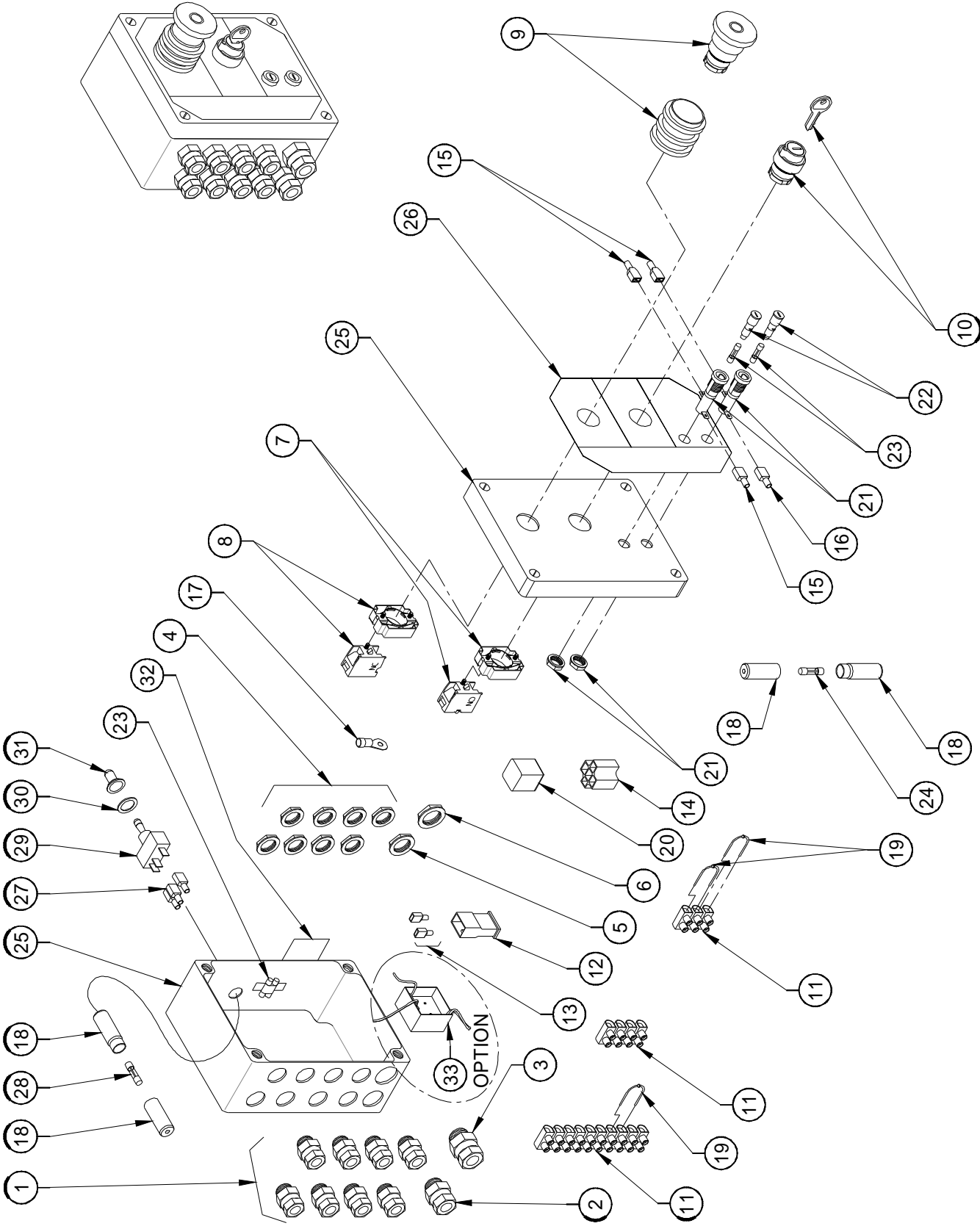

DATE : 22/03/04

LOWER CONTROL BOX ASSEMBLY

MONTAGE N°/

ASSY NO : SP0224 REV : C

ASSEMBLAGE BOITIER ELEC. BAS

1/1

DET NO.	REF./PART NUMBER	VOIR/ SEE VIEW	DESCRIPTION		R E V	Qté/ Qty Req.
1	210017		GLAND N°9	PRESSE ETOUPE N°9		8
2	210018		GLAND N°11	PRESSE ETOUPE N°11		1
3	210019		GLAND N°13	PRESSE ETOUPE N°13		1
4	210009		GLAND N°9 NUT	ECROU DE PRESSE ETOUPE N°9		8
5	210010		GLAND N°11 NUT	ECROU DE PRESSE ETOUPE N°11		1
6	210011		GLAND N°13 NUT	ECROU DE PRESSE ETOUPE N°13		1
7	240004		CONTACT BLOCK HOLDER NO	EMBASE CONTACT NO		1
8	240013		NC CONTACT BLOCK HOLDER	EMBASE CONTACT NC		1
9	240025		KNOB (EMERGENCY STOP SWITCH)	ARRET D'URGENCE		1
10	240032		2 POSITIONS SELECTOR	SELECTEUR 2 POSITION		1
11	250020		TERMINAL BLOCK	BARRETTE DE CONNEXION		17
12	250033		2 POSITIONS PLUG HOUSING	CONNECTEUR MALE 2 BROCHES		1
13	250035		RECEPTACLE TERMINAL 6.3mm	COSSE PLATE FEMELLE 6.3mm		2
14	250036		24V RELAY CONNECTOR	CONNECTEUR DE RELAIS 24V		1
15	250060		RECEPTACLE TERMINAL 4.8 - 0.25-1 mm ²	COSSE ISOLEE 4.8 mm 0.25-1 mm ²		3
16	250061		RECEPTACLE TERMINAL 4.8 - 1.5-2.5 mm ²	COSSE ISOLEE 4.8 mm 1.5-2.5 mm ²		1
17	250083		M06 EYELET TERMINAL 0.25-1mm ²	COSSE A ŒIL ISOLEE M6 - 0.25-1mm ²		1
18	260007		FUSE HOLDER	PORTE FUSIBLE	B	2
19	260010		DIODE	DIODE		3
20	260019		1RT 24V RELAY	RELAIS 24 V 1RT		1
21	260083		FUSE HOLDER	CORPS PORTE FUSIBLE	A	2
22	260084		FUSE HEAD	TETE PORTE FUSIBLE	A	2
23	260074		5A QUICK ACTING FUSE	FUSIBLE RAPIDE 5A		4
24	260104		500mA QUICK ACTING FUSE	FUSIBLE RAPIDE 500mA		1
25	SD0638		DRILLED ELECTRICAL BOX	BOITIER ELECTRIQUE PERCE	C	1
26	AU1879		LOWER CONTROL BOX DECAL	AUTOCOLLANT BOITIER BAS	C	1
27	250027		BLUE RECEPTACLE TER. 6.3 - 1.5-2.5mm ²	COSSE FEM. 6.3 BLEUE 6.3 - 1.5-2.5mm ²	B	3
28	260006		5x20 3.15A FUSE	FUSIBLE 5x20 3.15A	B	1
29	260133		SINGLE POLE TOGGLE SWITCH	INVERSEUR UNIPOLAIRE	B	1
30	260134		TOGGLE SWITCH GASKET	JOINT D'INVERSEUR	B	1
31	260135		TOGGLE SWITCH COVER	PROTECTION D'INTERRUPTEUR	B	1
32	AU1124		WATER CAN DECAL	AUTOCOLLANT BIDON D'EAU	B	1
33	290058		POWER TIMER	TEMPORISATION MACHINE	C	1

SPARE PARTS
PIECES DETACHEES

SECTION 4.

CHARGER INSTALL.
INSTALLATION CHARGEUR.



CHARGER INSTALL INSTALLATION CHARGEUR

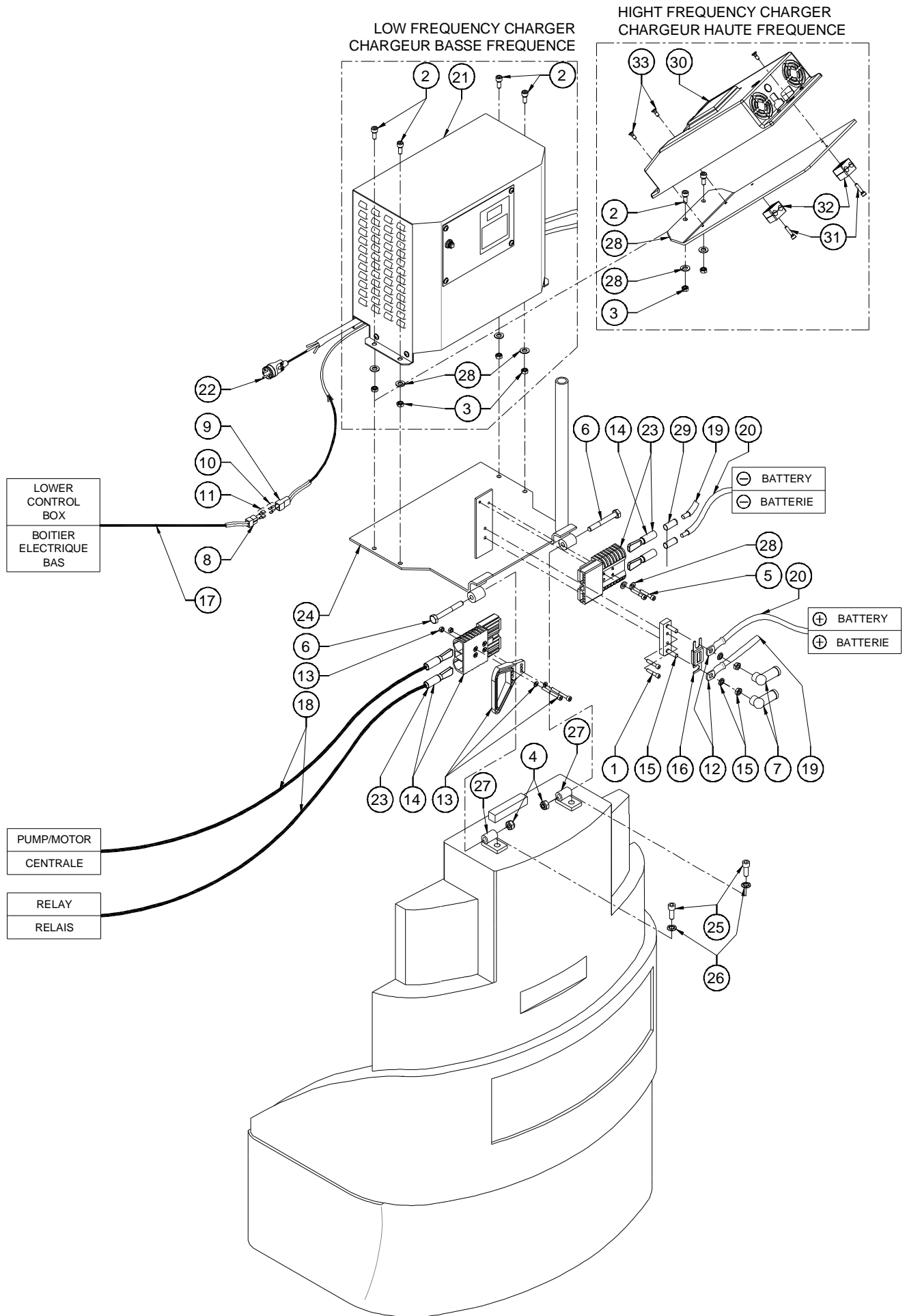

DATE : 22/03/04

CHARGER INSTALLMONTAGE N°/
ASSY NO : SP0211 REV : D**INSTALLATION CHARGEUR**

1/1

DET NO.	REF./PART NUMBER	VOIR/ SEE VIEW	DESCRIPTION		R E V	Qté/ Qty Req.
1	000005		M06x20 8.8 SOCKET HEAD MACH SCREW	VIS CHC M06x20 8.8 BI FT		2
2	000018		M08x16 8.8 SOCKET HEAD MACH SCREW	VIS CHC M08x16 8.8 BI FT		4
3	110004		M08 GR. 8.8 LOCK NUT	ECROU FREIN M8 8.8 BI		4
4	110005		M10 GR. 8.8 LOCK NUT	ECROU FREIN M10 8.8 BI		2
5	000077		M06x35 8.8 SOCKET HEAD CAPSCREW	VIS CHC M06x35 8.8 BI FP	C	2
6	100091		M10x80 8.8 HEX HEAD CAPSCREW	VIS H M10x80 8.8 BI FP		2
7	250031		TERMINAL CAP	CAPUCHON D'ETANCHEITE		2
8	250033		2 POSITIONS PLUG HOUSING	CONNECTEUR MALE 2 BROCHES	C	1
9	250032		2 POSITIONS CAP HOUSING	CONNECTEUR FEMELLE 2 BROCHES	C	1
10	250034		BLADE TERMINAL 6.3mm	COSSE PLATE MALE 6.3mm		2
11	250035		RECEPTACLE TERMINAL 6.3mm	COSSE PLATE FEMELLE 6.3mm		2
12	250030		Ø8 EYELET CRIMP TERMINAL 35 mm²	COSSE A ŒIL Ø 8 - 35 mm²		2
13	250101		QUICK CONNECTOR HANDLE KIT	POIGNEE POUR PRISE RAPIDE		1
14	250102		QUICK CONNECTOR	CONNECTEUR RAPIDE		2
15	260077		POWER FUSE HOLDER	PORTE FUSIBLE DE PUISSANCE		1
16	260079		325A FUSE	FUSIBLE 325A		1
17	270010		CABLE 2x1mm² (quantity indicated in meter)	CABLE 2x1mm² (qté indiquée en mètre)		1
18		SECTION 3	WIRE 35 mm²	CABLE 35 mm²		x
19	270021		WIRE 35mm² (quantity indicated in meter)	CABLE 35mm² (qté indiquée en mètre)		0.35
20		APPENDIX F	BATTERY WIRE	CABLE BATTERIE		2
21		APPENDIX F	LOW FREQUENCY CHARGER	CHARGEUR BASSE FREQUENCE		1
22		APPENDIX F	CHARGER CONNECTOR	PRISE CHARGEUR	C	1
23	910031		2 BLADE CONTACTS (included in 250102)	2 COSSES PRISE (inclus dans 250102)		2
24	DL0590		CHARGER SUPPORT	SUPPORT CHARGEUR	C	1
25	100021		M12x25 8.8 HEX HEAD MACHINE SCREW	VIS H M12x25 8.8 BI FT	B	2
26	120015		dD 12x27 LOCK WASHER	RONDELLE CONTACT dD 12x27 BI	B	2
27	DL0421		CHARGER SUPPORT ATTACHMENT	FIXATION SUPPORT CHARGEUR	A	2
28	120009		dD 06x14 LOCK WASHER	RONDELLE CONTACT dD 06x14 BI	D	6
29	250192		REDUCEUR CAP 50 mm²	EMBOUT REDUCTEUR 50 mm²	C	2
30		APPENDIX F	HIGHT FREQUENCY CHARGER	CHARGEUR HAUTE FREQUENCE	D	1
31	000008		M06x25 8.8 SOCKET HEAD MACH SCREW	VIS CHC M06x25 8.8 BI FT	D	2
32	400018		PAIR 1/2 SHELL D12.7	PAIRE DEMI COQUILLE D12.7	D	2
33	130003		M06x16 10.9 COUNTERSUNK HEAD M. S.	VIS FHC M06x16 10.9 BI FT	D	3

SPARE PARTS
PIECES DETACHEES

SECTION 5.

**CHANNEL AND POWER BRIDGE INSTALL.
INSTALLATION GOULOTTES ET CHAINES PORTE
CABLES.**



CHANNEL AND POWERBRIDGE INSTALL INSTALLATION GOULOTTES ET CHAINES PORTE CABLES

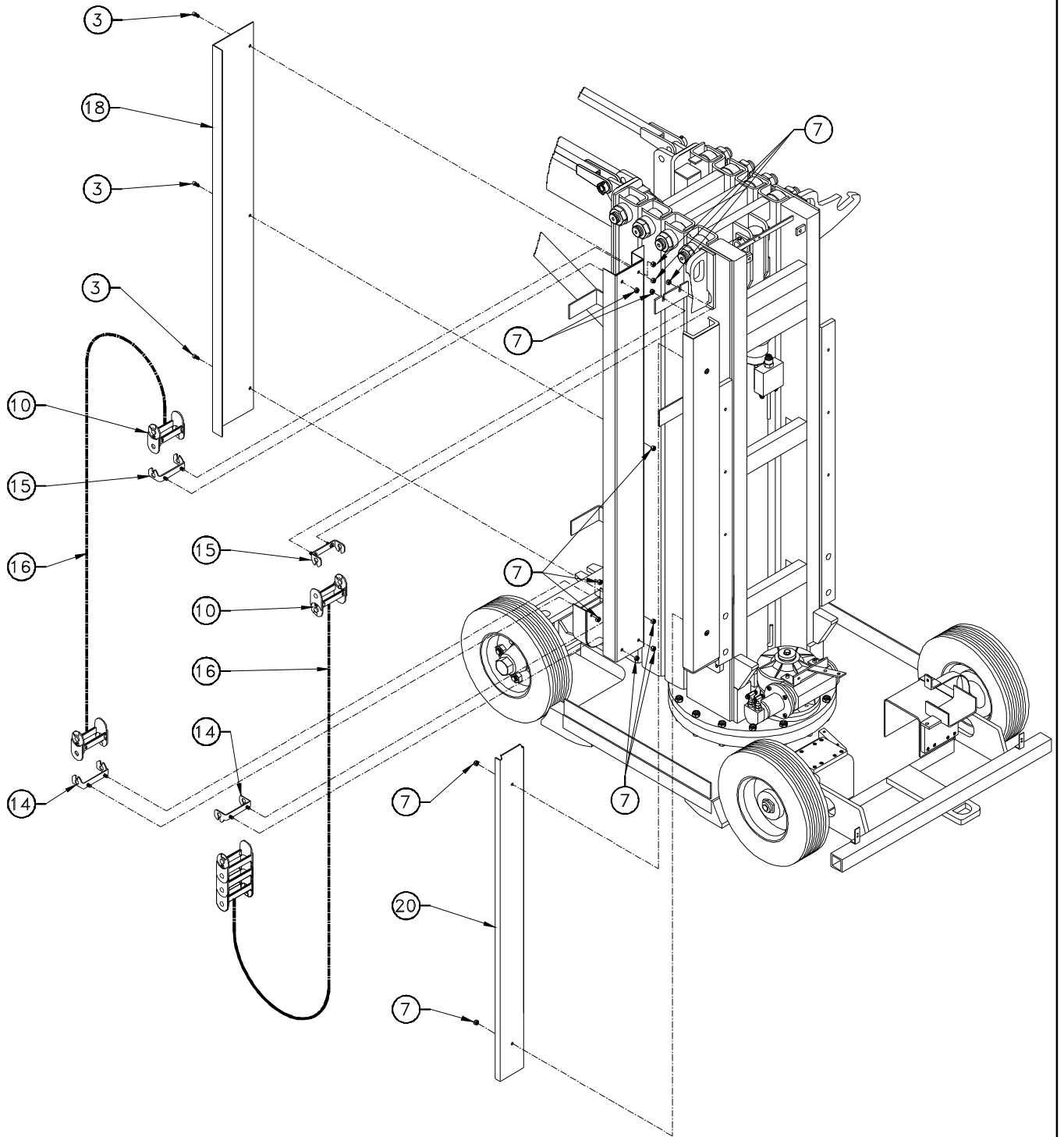

CHANNEL AND POWERBRIDGE INSTALL INSTALLATION GOULOTTES ET CHAINES PORTE CABLES

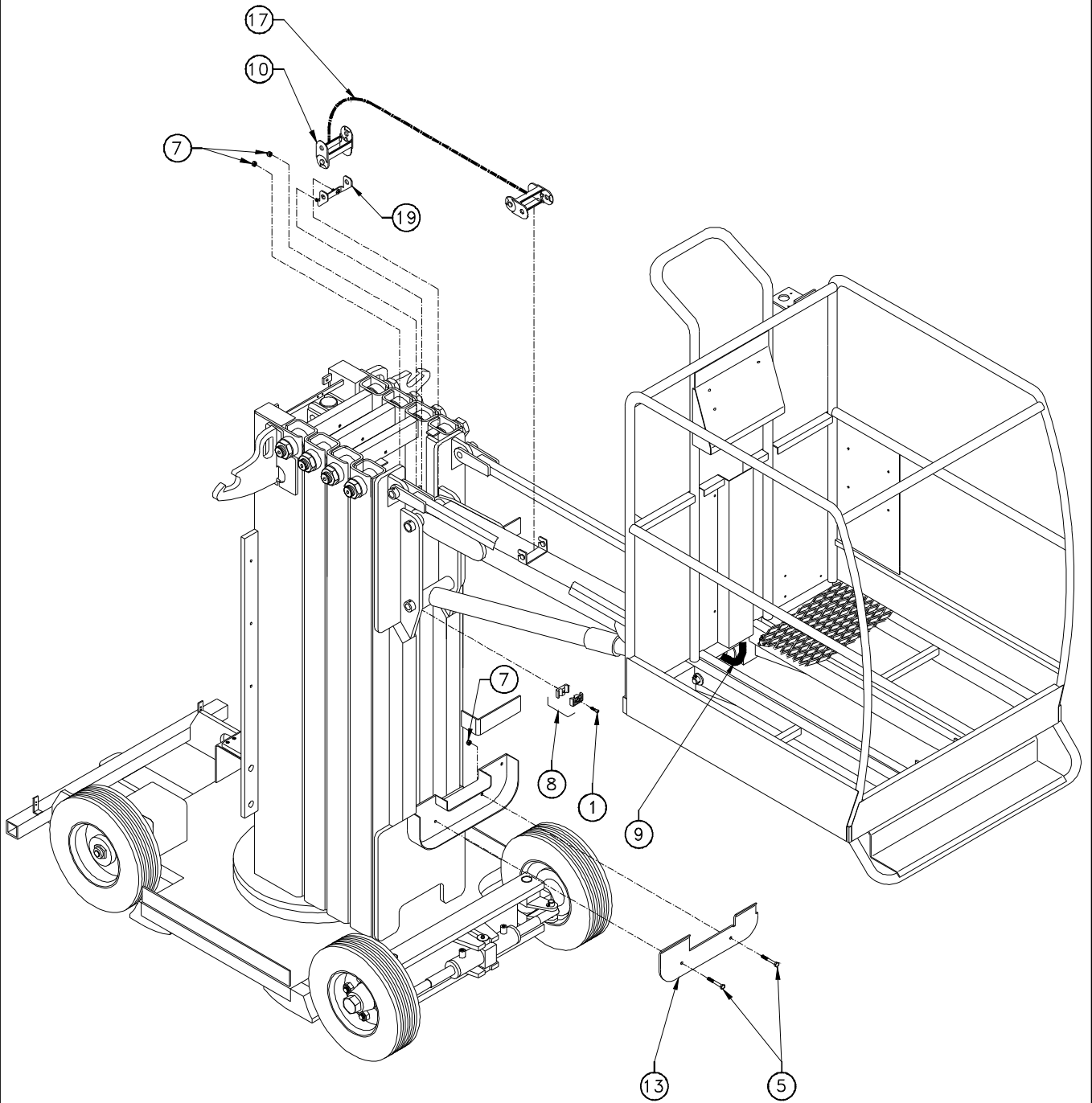

CHANNEL AND POWERBRIDGE INSTALL INSTALLATION GOULOTTES ET CHAINES PORTE CABLES

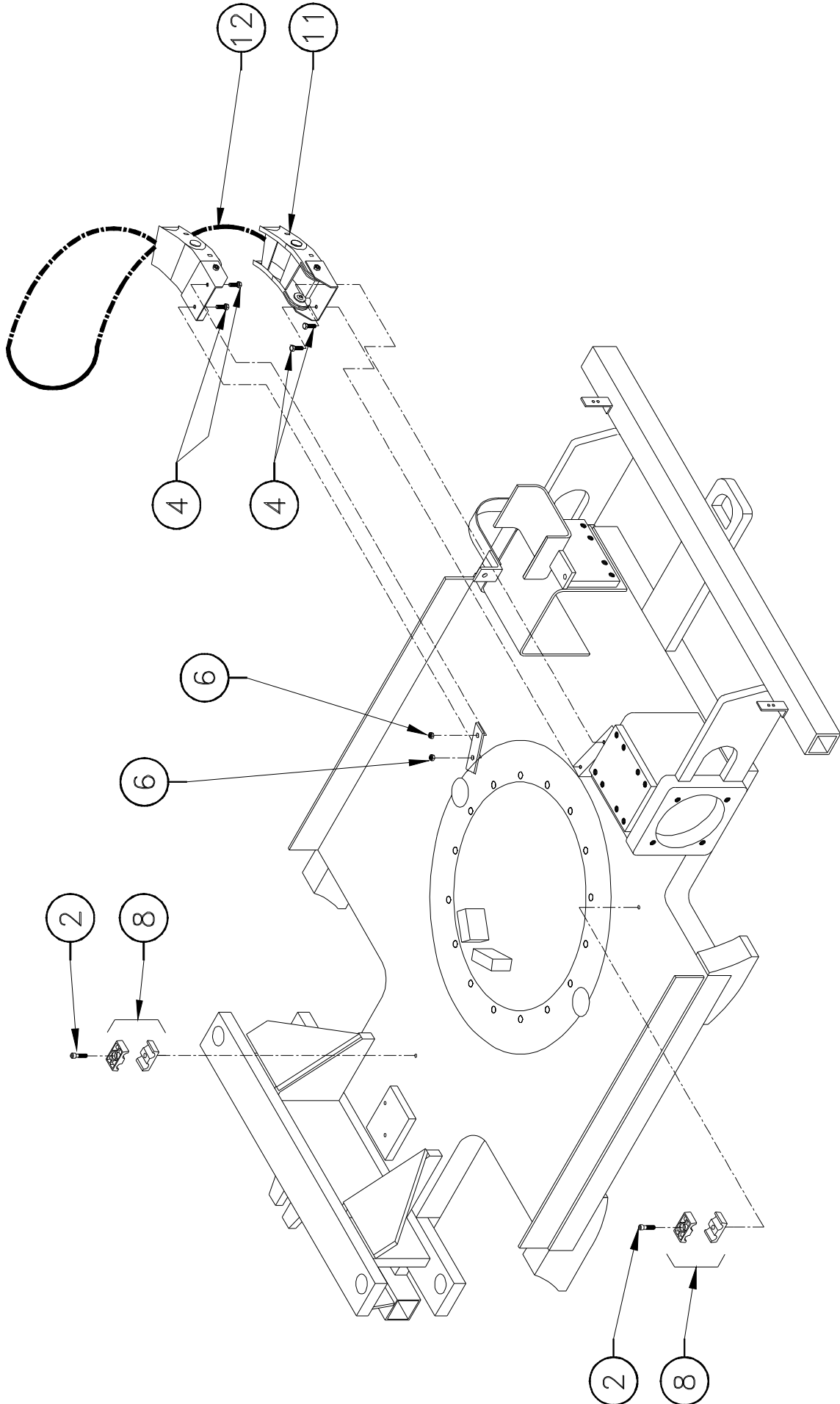

DATE : 12/01/98

**CHANNEL AND POWER BRIDGE
INSTALL**

MONTAGE N°/

ASSY NO : SP0225 REV :

**INSTALLATION CHAINES PORTE
CABLES**

1/1

DET NO.	REF./PART NUMBER	VOIR/ SEE VIEW	DESCRIPTION		R E V	Qté/ Qty Req.
1	000005		M06x20 8.8 SOCKET HEAD MACH SCREW	VIS CHC M06x20 8.8 BI FT		1
2	000008		M06x25 8.8 SOCKET HEAD MACH SCREW	VIS CHC M06x25 8.8 BI FT		2
3	000018		M08x16 8.8 SOCKET HEAD MACH SCREW	VIS CHC M08x16 8.8 BI FT		3
4	100098		M06x16 8.8 HEX HEAD MACHINE SCREW	VIS H M06x16 8.8 BI FT		4
5	100140		M08x60 8.8 HEX HEAD CAPSCREW	VIS H M08x60 8.8 BI FP		2
6	110003		M06 GR. 8.8 LOCK NUT	ECROU FREIN M6 8.8 BI		2
7	110004		M08 GR. 8.8 LOCK NUT	ECROU FREIN M8 8.8 BI		16
8	400018		PAIR 1/2 SHELL D12.7	PAIRE DEMI COQUILLE D12.7		3
9	400021		SHEAT HOSES (quantity indicated in meter)	GAINE FLEXIBLES (quantité en mètres)		1
10	920001		POWER BRIDGE LINK	MAILLON DE CHAINE		x
11	920002		SWING POWER BRIDGE LINK	MAILLON DE CHAINE CIRCULAIRE		x
12	ST0175		SWING POWER BRIDGE	CHAINE PORTE CABLE CIRCULAIRE		1
13	ST0333		HOSE GUARD COVER / MAST 5	TOLE GOULOTTE MAT 5		1
14	ST0339		MOUNTING BRACKET WITH PIN	EQUERRE AVEC AXE		2
15	ST0340		MOUNTING BRACKET WITHOUT PIN	EQUERRE AVEC PERCAGE		2
16	ST0341		POWER BRIDGE	CHAINE PORTE CABLE		2
17	ST0342		JIB POWER BRIDGE	CHAINE PORTE CABLE DU BRAS		1
18	ST0402		HOSE GUARD COVER / MAST 3	TOLE GOULOTTE MAT 3		1
19	ST0439		JIB MOUNTING BRACKET	EQUERRE CHAINE BRAS		1
20	ST1336		HOSE GUARD COVER / MAST 1	TOLE GOULOTTE MAT 1		1

SPARE PARTS
PIECES DETACHEES

SECTION 6.

HYDRAULIC INSTALL.
INSTALLATION HYDRAULIQUE.



HYDRAULIC INSTALL INSTALLATION HYDRAULIQUE

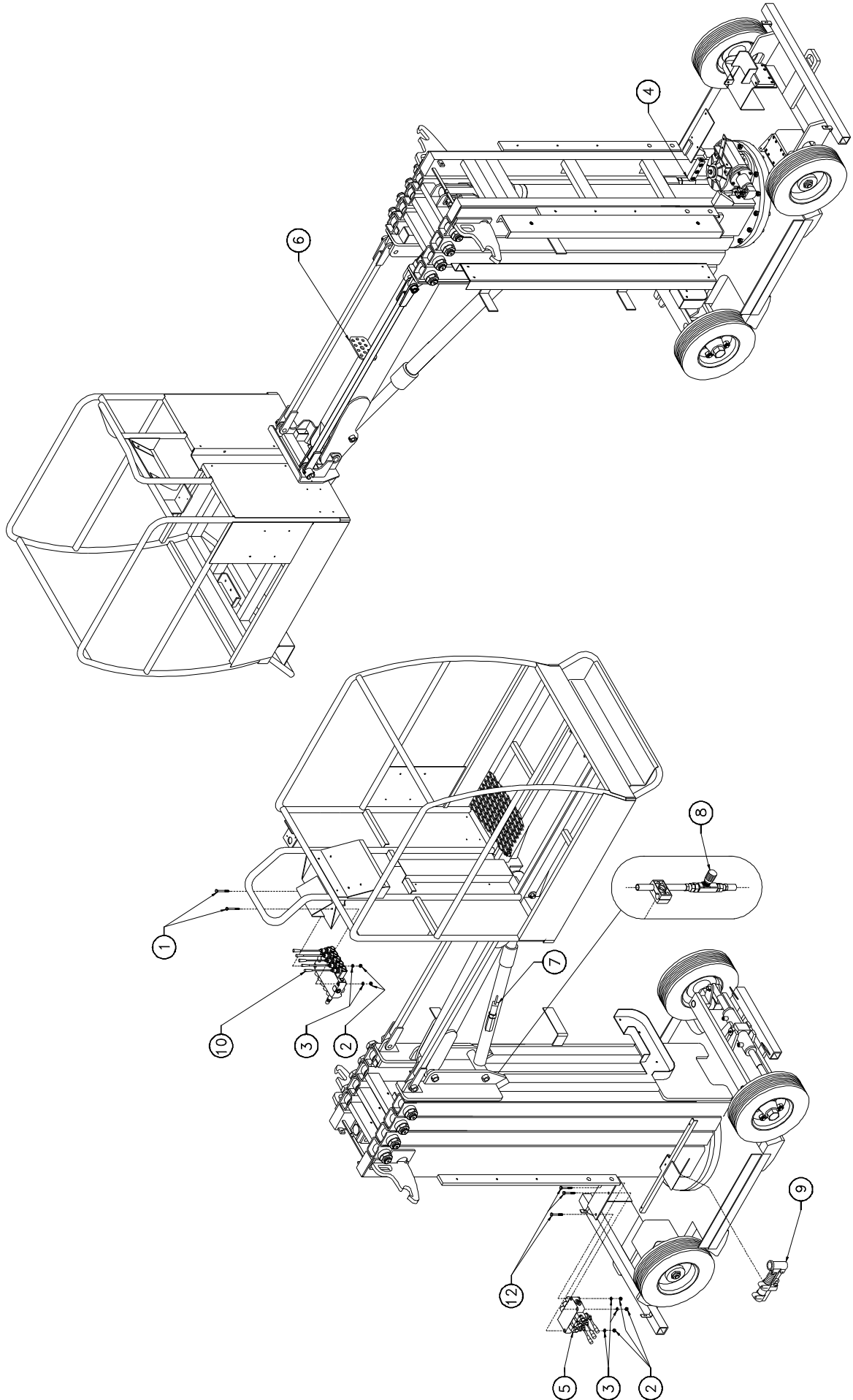

MAST CYLINDER ASSEMBLY ASSEMBLAGE VERIN DE MAT

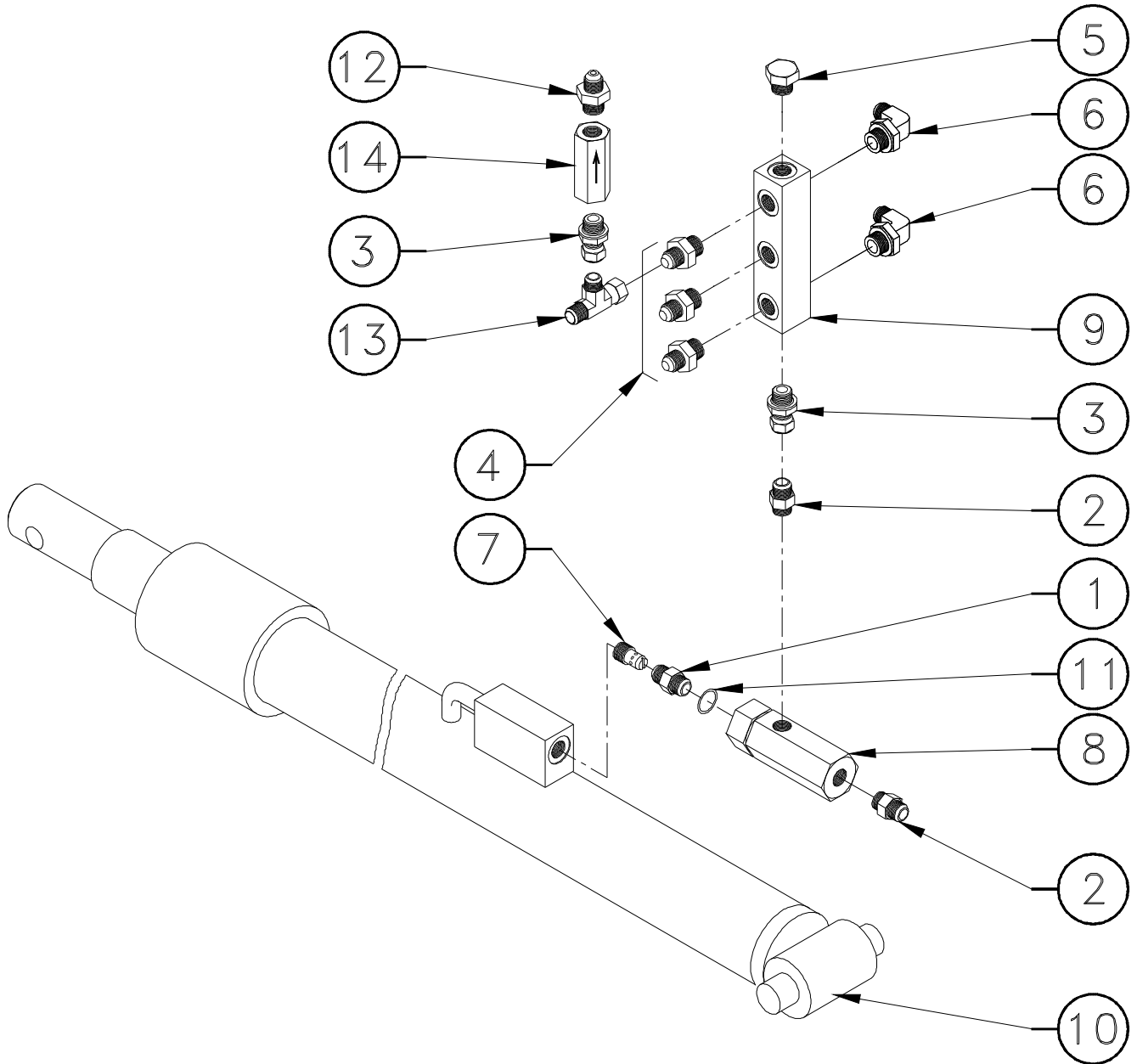

DATE : 12/05/99

MAST CYLINDER ASSEMBLY

MONTAGE N°/

ASSY NO : SP0221 REV : A

ASSEMBLAGE VERIN DE MAT

1/1

DET NO.	REF./PART NUMBER	VOIR/ SEE VIEW	DESCRIPTION		REVIEW	Qté/ Qty Req.
1	300107		FITTING MALE BSPP 1/4- MALE BSPT 3/8	RAC. MALE BSPP 1/4-MALE BSPT 3/8	A	1
2	300025		FITTING MALE BSPP1/4-MALE JIC9/16	RACCORD MALE BSPP1/4-MALE JIC9/16		2
3	300027		FITTI. MALE BSPP3/8-FEM.JIC9/16 SWIVEL	UNION MALE BSPP 3/8 -TOUR. JIC 9/16	A	2
4	300040		FITTING MALE BSPP3/8 MALE JIC9/16	RACCORD MALE BSPP3/8 MALE JIC9/16		3
5	300047		CAP BSPP 3/8	BOUCHON BSPP 3/8		1
6	300061		90° ELBOW MALE BSPP 3/8-MALE JIC 9/16	COUDE 90° MALE BSPP3/8-MALE JIC9/16		2
7	310037		FLOW REGULATOR VALVE 9L/mn	REGULATEUR DE DEBIT 9L/mn		1
8	320001		PILOT CHECK VALVE	CLAPET ANTI RETOUR PILOTE		1
9	520036		MANIFOLD	BLOC FORE		1
10		APPENDIX A	MAST CYLINDER	VERIN DE MAT		1
11	300108		BUSHING BS	BAGUE BS	A	1
12	300022		FITTING MALE BSPP 3/8- MALE JIC 7/16	RAC. MALE BSPP 3/8-MALE JIC 7/16	A	1
13	300037		RUN TEE JIC 9/16 SWIVEL NUT	TE MALE JIC9/16-FEMELLE JIC9/16 TOUR.	A	1
14	310023		CHECK VALVE 4.5 BAR BSPP 3/8	CLAPET ANTI RETOUR 4.5 BAR BSPP 3/8	A	1

LOWER VALVE ASSEMBLY ASSEMBLAGE DISTRIBUTEUR BAS

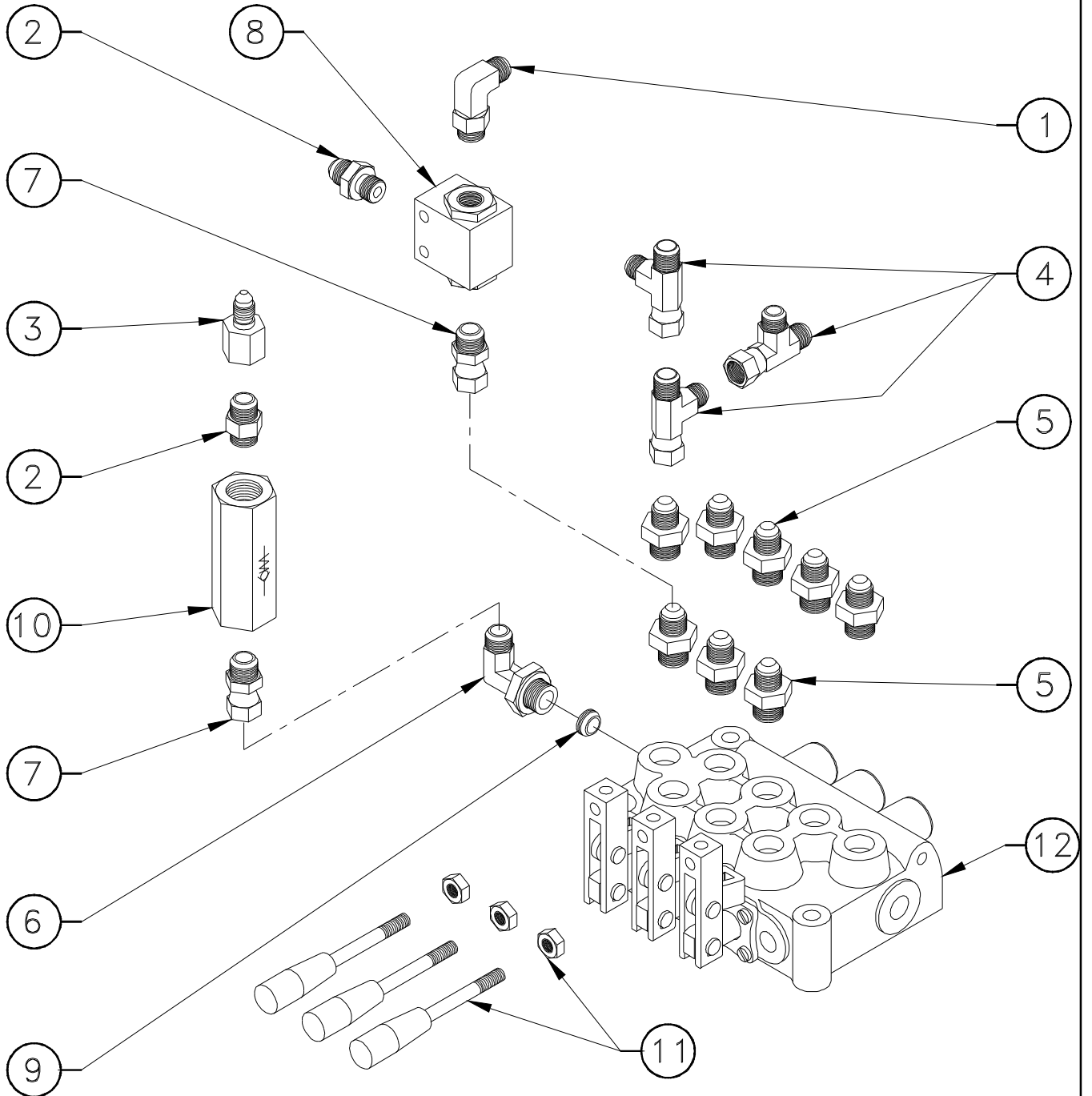

DATE : 19/01/98

LOWER VALVE ASSEMBLY

MONTAGE N°/

ASSY NO : SP0236 REV :

ASSEMBLAGE DISTRIBUTEUR BAS

1/1

DET NO.	REF./PART NUMBER	VOIR/ SEE VIEW	DESCRIPTION		REVISION	Qté/ Qty Req.
1	300001		90° ELBOW MALE BSPP 1/4-MALE JIC 9/16	COUDE 90° Male BSPP 1/4 -Male JIC 9/16		1
2	300025		FITTING MALE BSPP1/4-MALE JIC9/16	RACCORD MALE BSPP1/4-MALE JIC9/16		2
3	300030		ADAPTER FEMALE JIC9/16-MALE JIC7/16	REDUC. FEMELLE JIC9/16-MALEJIC7/16		1
4	300037		RUN TEE JIC 9/16 SWIVEL NUT	TE MALE JIC9/16-FEMELLE JIC9/16 TOUR.		3
5	300040		FITTING MALE BSPP3/8 MALE JIC9/16	RACCORD MALE BSPP3/8 MALE JIC9/16		8
6	300061		90° ELBOW MALE BSPP 3/8-MALE JIC 9/16	COUDE 90° MALE BSPP3/8-MALE JIC9/16		1
7	300073		FITTING MALE BSPP 1/4-FEMALE JIC 9/16	RACC. MALE BSPP 1/4 -FEM. JIC 9/16		2
8	310019		SHUTTLE VALVE HOUSING BSPP 1/4	SELECTEUR DE CIRCUIT BSPP 1/4		1
9	310056		CAP	BOUCHON		1
10	310060		CHECK VALVE	CLAPET ANTI RETOUR		1
11	900025		VALVE HANDLE WITH NUT	LEVIER AVEC ECROU		3
12	320021	320021	VALVE	DISTRIBUTEUR		1

BULKHEAD ASSEMBLY ASSEMBLAGE TRAVERSEE DE CLOISON

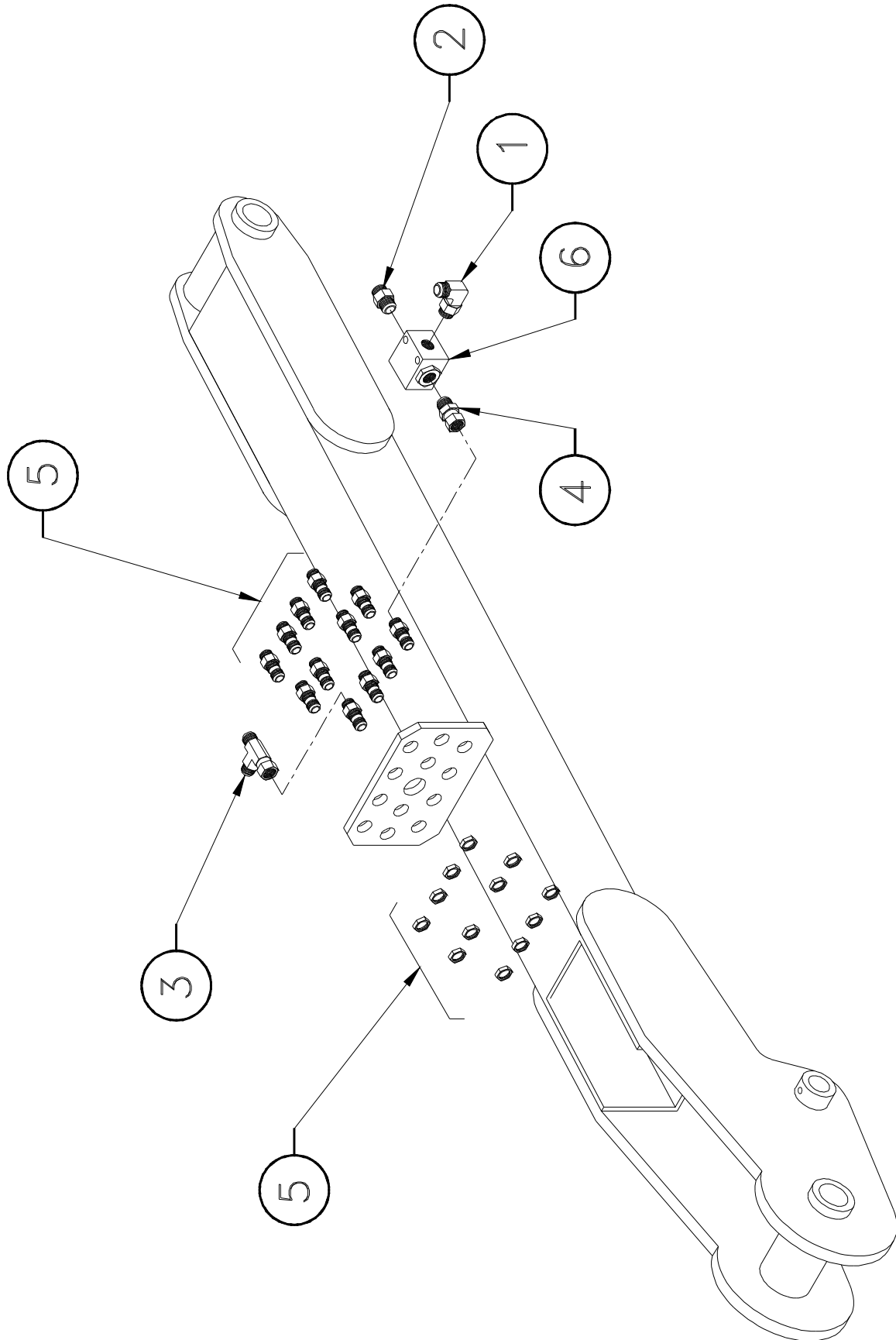

JIB CYLINDER ASSEMBLY ASSEMBLAGE VERIN DE BRAS

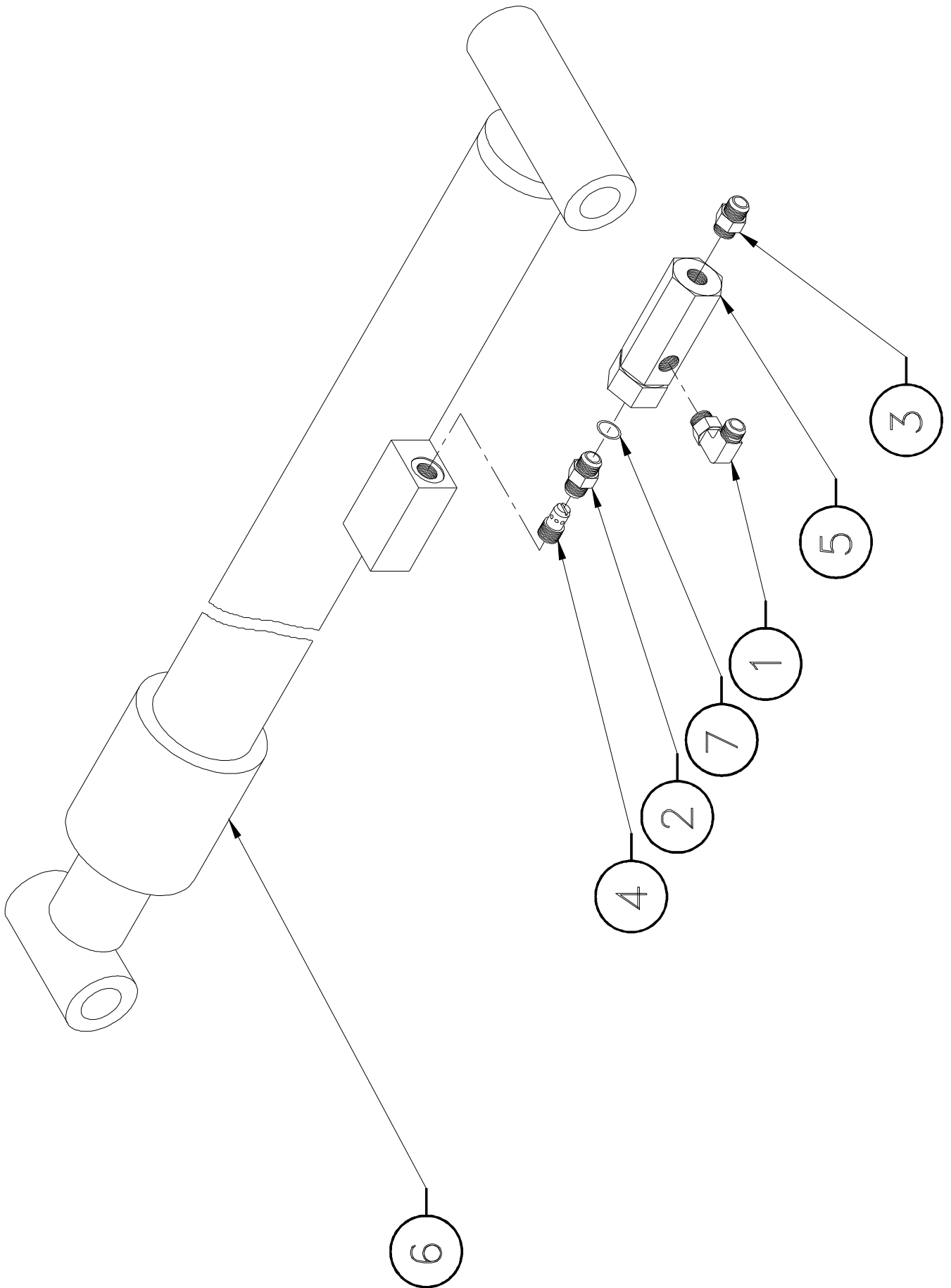

JIB FLOW CONTROL ASSEMBLY ASSEMBLAGE ETRANGLEUR BRAS

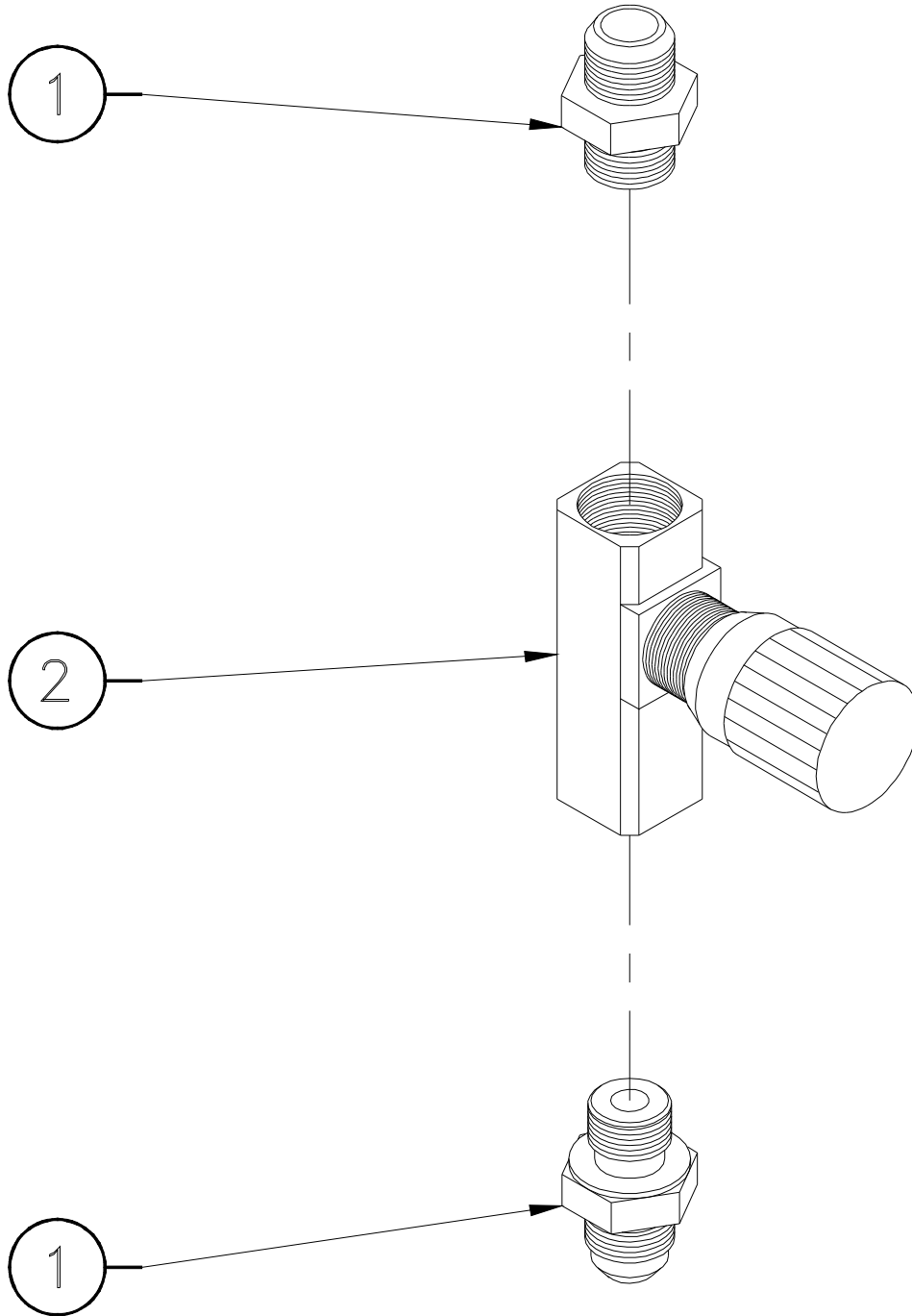

HAND PUMP ASSEMBLY ASSEMBLAGE POMPE A MAIN

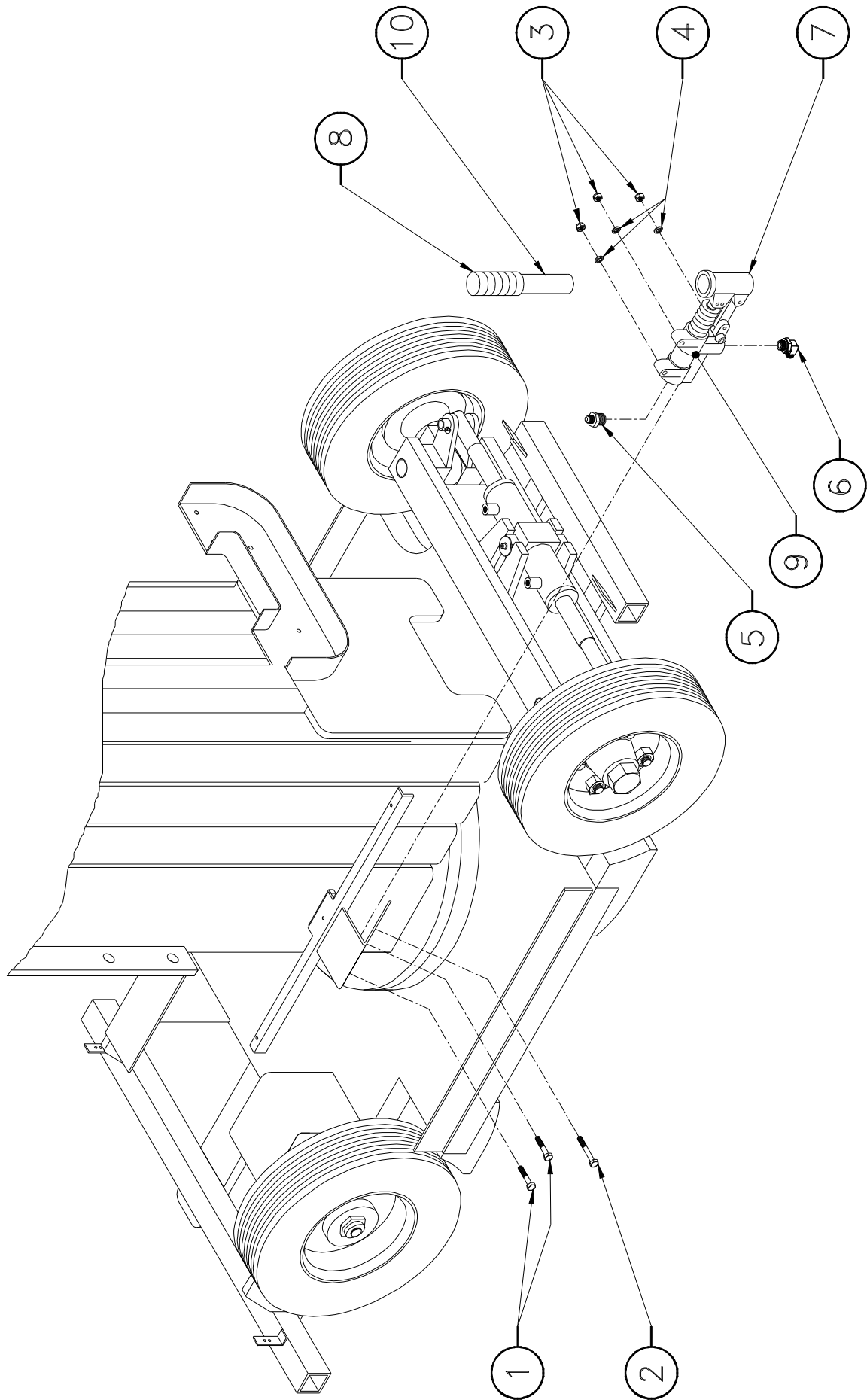

DATE : 15/01/98

HAND PUMP ASSEMBLY

MONTAGE N°/

ASSY NO : SP0240 REV :

ASSEMBLAGE POMPE A MAIN

1/1

DET NO.	REF./PART NUMBER	VOIR/SEE VIEW	DESCRIPTION		RE V	Qté/Qty Req.
1	100093		M08x45 8.8 HEX HEAD MACHINE SCREW	VIS H M08x45 8.8 BI FT		2
2	100140		M08x60 8.8 HEX HEAD CAPSCREW	VIS H M08x60 8.8 BI FP		1
3	110004		M08 GR. 8.8 LOCK NUT	ECROU FREIN M8 8.8 BI		3
4	120010		dD 08x18 LOCK WASHER	RONDELLE CONTACT dD 08x18 BI		3
5	300044		FITTING MALE BSPP1/2-MALE JIC9/16	RACCORD MALE BSPP1/2-MALE JIC9/16		1
6	300061		90° ELBOW MALE BSPP 3/8-MALE JIC 9/16	COUDE 90° MALE BSPP3/8-MALE JIC9/16		1
7	320007		HAND PUMP	POMPE A MAIN		1
8	930109		PUMP HANDLE RUBBER	CAOUTCHOU C POIGNEE POMPE		1
9	930110		SEAL KIT	KIT DE JOINTS		1
10	DL0113		HAND PUMP HANDLE	MANCHE DE POMPE A MAIN		1

HYDRAULIC SCHEMATIC SCHEMA HYDRAULIQUE

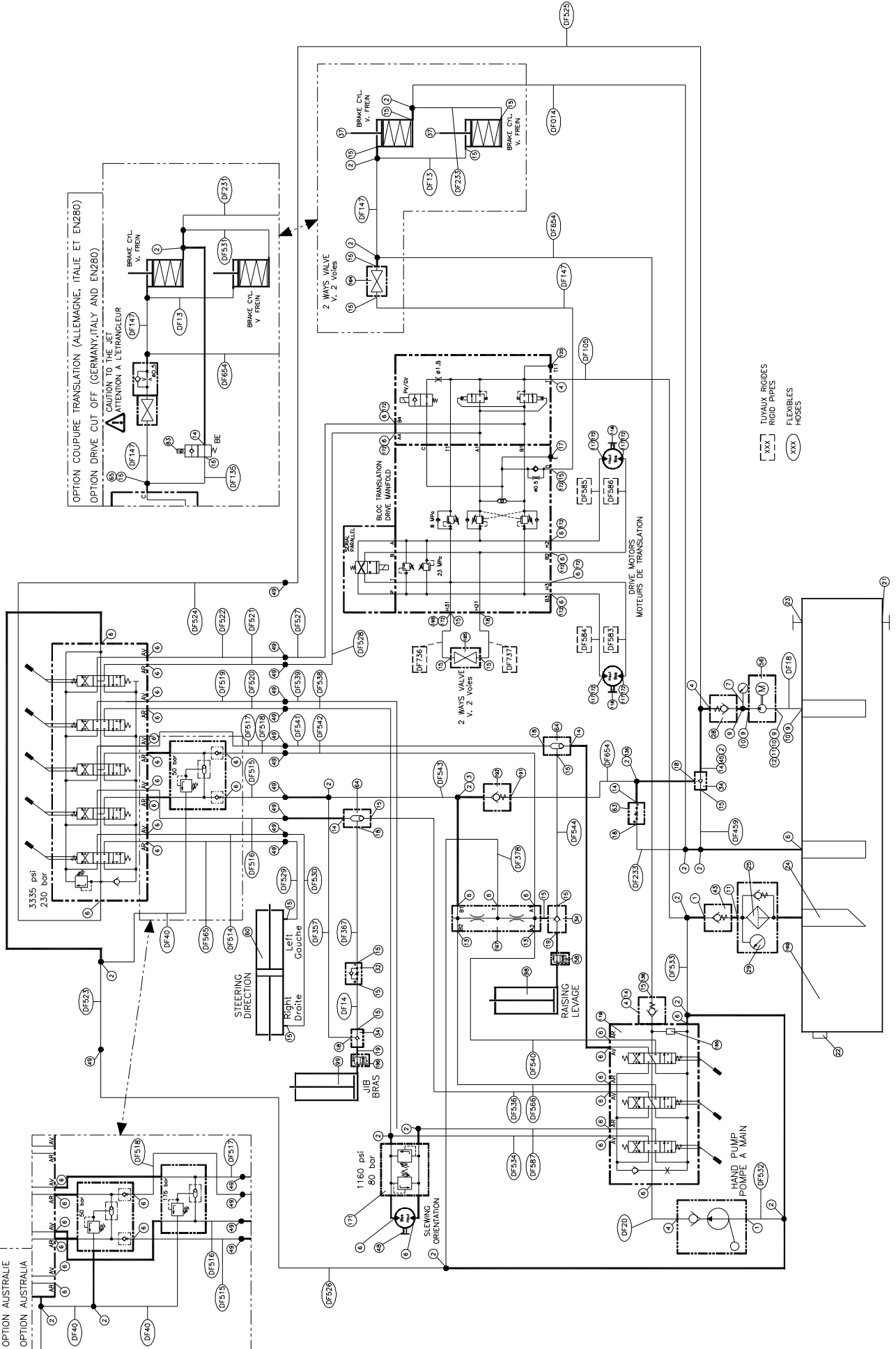

SPARE PARTS
PIECES DETACHEES

SECTION 7.

MAST INSTALL.
INSTALLATION DES MATS.



MAST INSTALL INSTALLATION DES MATS

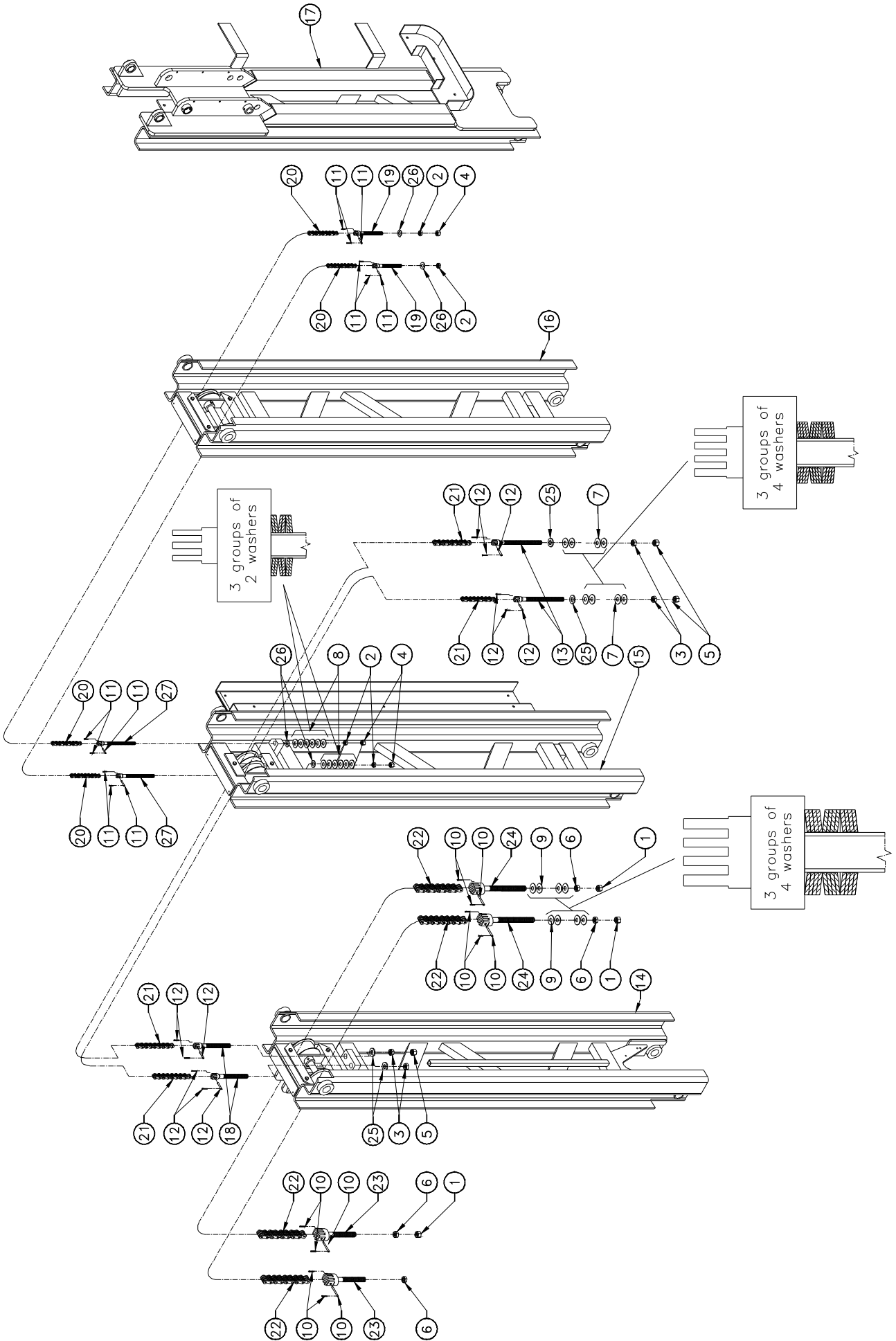

DATE : 05/12/97

MAST INSTALL

MONTAGE N°/

ASSY NO : SP0202 REV :

INSTALLATION MATS

1/1

DET NO.	REF./PART NUMBER	VOIR/ SEE VIEW	DESCRIPTION		RE V	Qté/ Qty Req.
1	110006		M20 GR. 8.8 LOCK NUT	ECROU FREIN M20 8.8 BI		3
2	110009		M14 GR. 8.8 HEX NUT	ECROU H M14 8.8 BI		4
3	110010		M16 GR. 8.8 HEX NUT	ECROU H M16 8.8 BI		4
4	110019		M14 GR. 8.8 LOCK NUT	ECROU FREIN H M14 8.8 BI		3
5	110020		M16 GR. 8.8 LOCK NUT	ECROU FREIN M16		3
6	110025		M20 GR. 8.8 HEX NUT	ECROU H M20 8.8 BI		4
7	120006		Ø34x16.3x1.5 SPRING WASHER	RONDELLE RESSORT Ø34x16.3x1.5 BI		24
8	120017		SPRING WASHER Ø34x14.3x1.5	RONDELLE RESSORT Ø34x14.3x1.5 BI		12
9	120018		SPRING WASHER Ø40x20.4x2	RONDELLE RESSORT 40x20.4x2 BI		24
10	170002		M20 CLEVIS PIN	AXE DE CHAPE M20		4
11	170007		M14 CLEVIS PIN	AXE DE CHAPE M14		4
12	170008		M16 CLEVIS PIN	AXE DE CHAPE M16		4
13	170010		CHAIN ANCHOR M16x160 LG	CHAPE DE CHAINE M16x160		2
14	SP0203		MAST 2 ASSEMBLY	ASSEMBLAGE MAT 2		1
15	SP0204		MAST 3 ASSEMBLY	ASSEMBLAGE MAT 3		1
16	SP0205		MAST 4 ASSEMBLY	ASSEMBLAGE MAT 4		1
17	SP0206		MAST 5 ASSEMBLY	ASSEMBLAGE MAT 5		1
18	ST0099		CHAIN ANCHOR M16x80 LG	CHAPE DE CHAINE M16x80		2
19	ST0120		CHAIN ANCHOR M14x90 LG	CHAPE DE CHAINE M14x90		2
20	ST1366		CHAIN LL 10-40	CHAINE DE LEVAGE LL 10-40		2
21	ST1365		CHAIN LL 12-66	CHAINE DE LEVAGE LL 12-66		2
22	ST1288		CHAIN LH 12-66	CHAINE DE LEVAGE LH 12-66		2
23	ST0752		CHAIN ANCHOR M20x80 LG	CHAPE M20x80		2
24	ST0828		CHAIN ANCHOR M20x135 LG	CHAPE M20x135		2
25	US0198		dDH 33x17x4 WASHER	RONDELLE dDH 33x17x4		4
26	120025		Ddh 28x14x2.5 WASHER	RONDELLE Ddh 28x14x2.5 BI		4
27	170009		M14x150 LG. CHAIN ANCHOR	CHAPE DE CHAINE M14x150		2

MAST 2 ASSEMBLY ASSEMBLAGE MAT 2

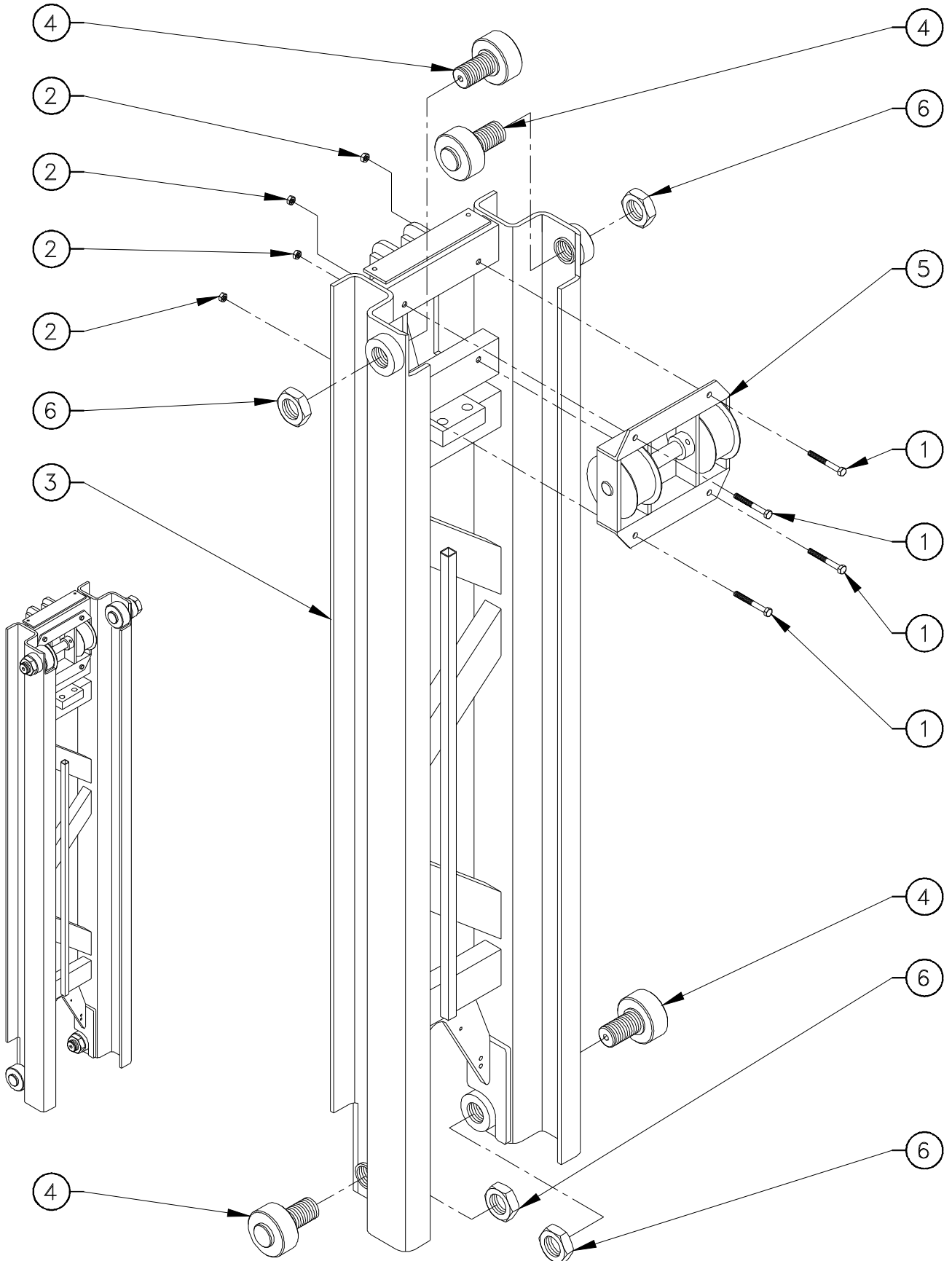

MAST 3 ASSEMBLY ASSEMBLAGE MAT 3

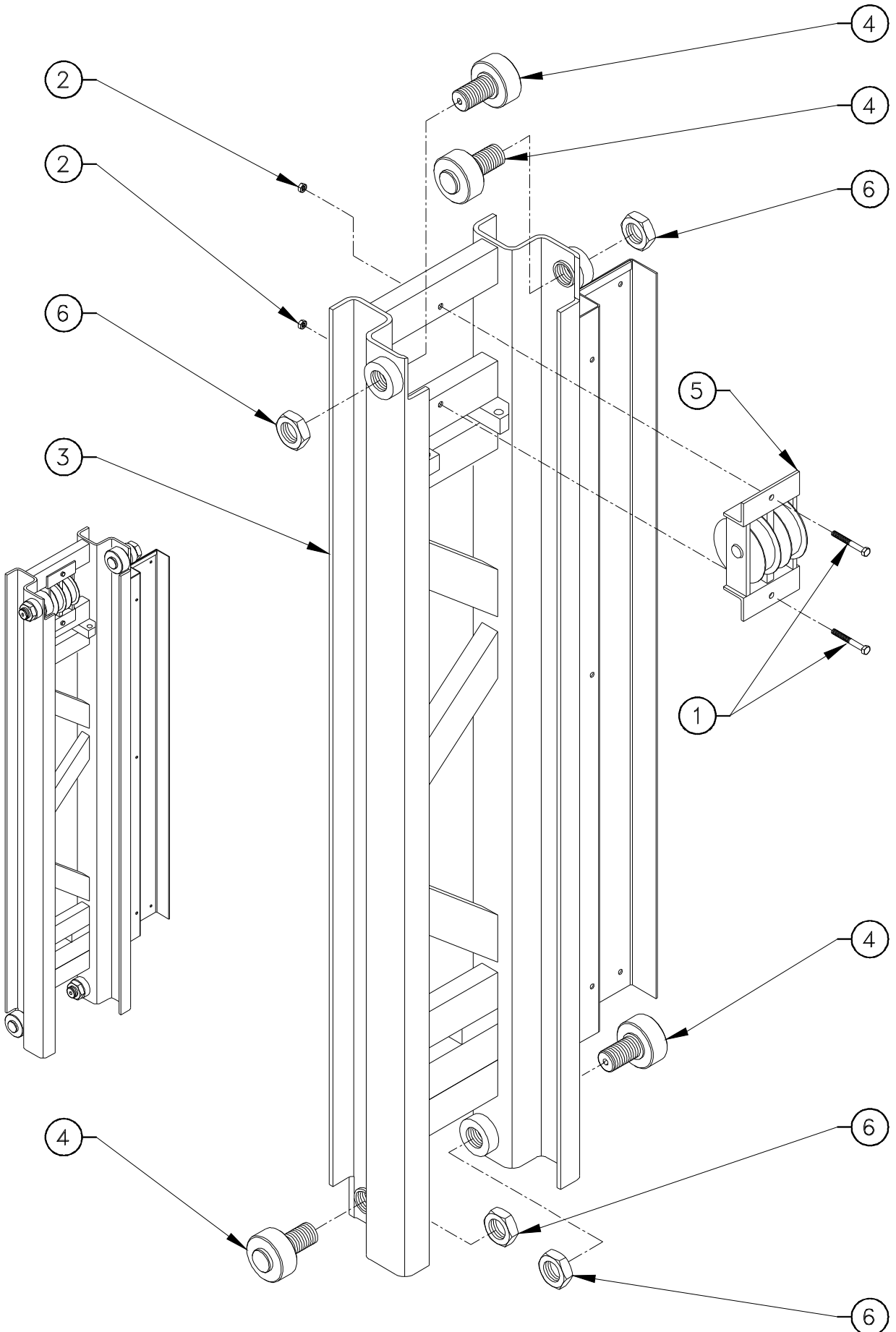

MAST 4 ASSEMBLY ASSEMBLAGE MAT 4

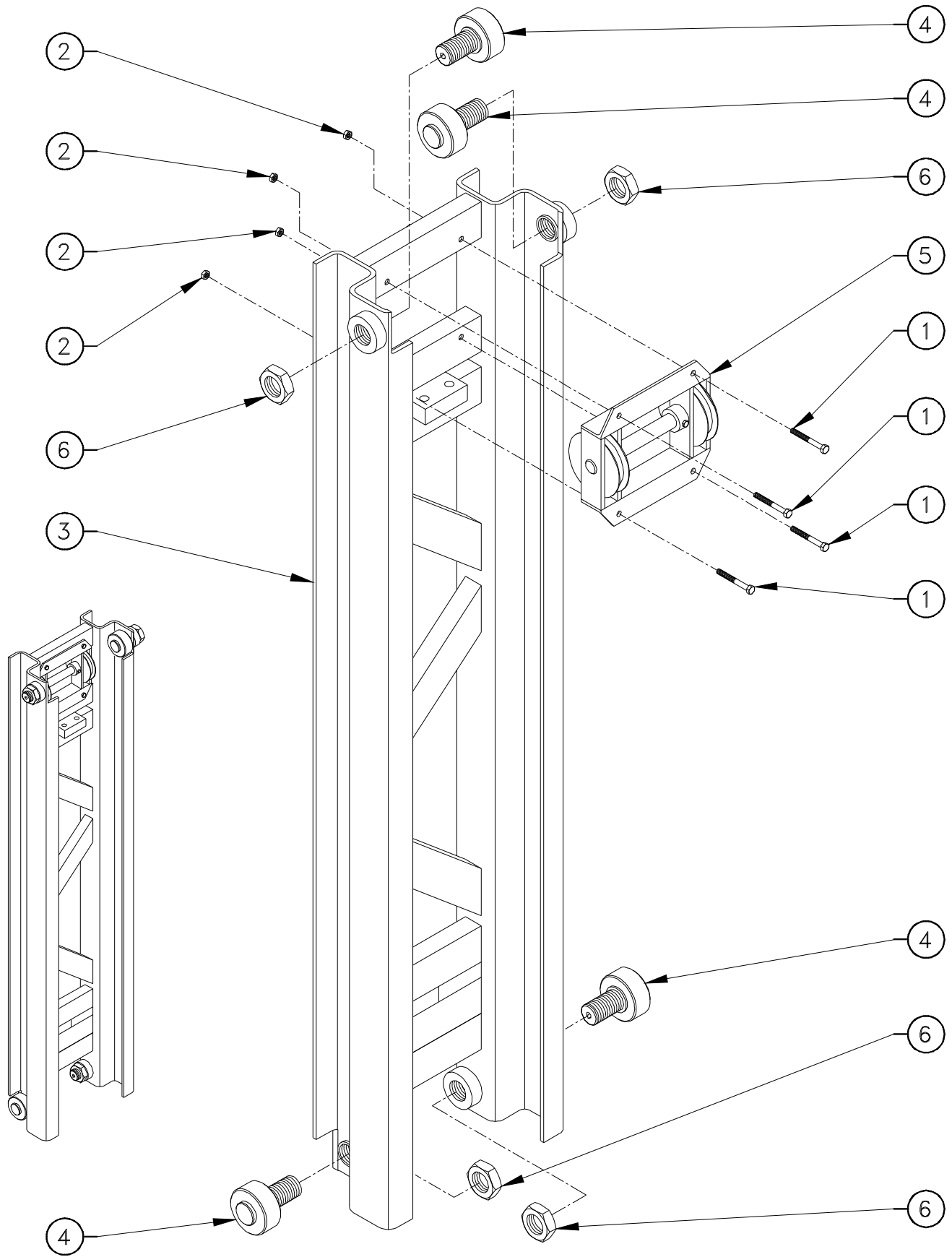

MAST 5 ASSEMBLY ASSEMBLAGE MAT 5

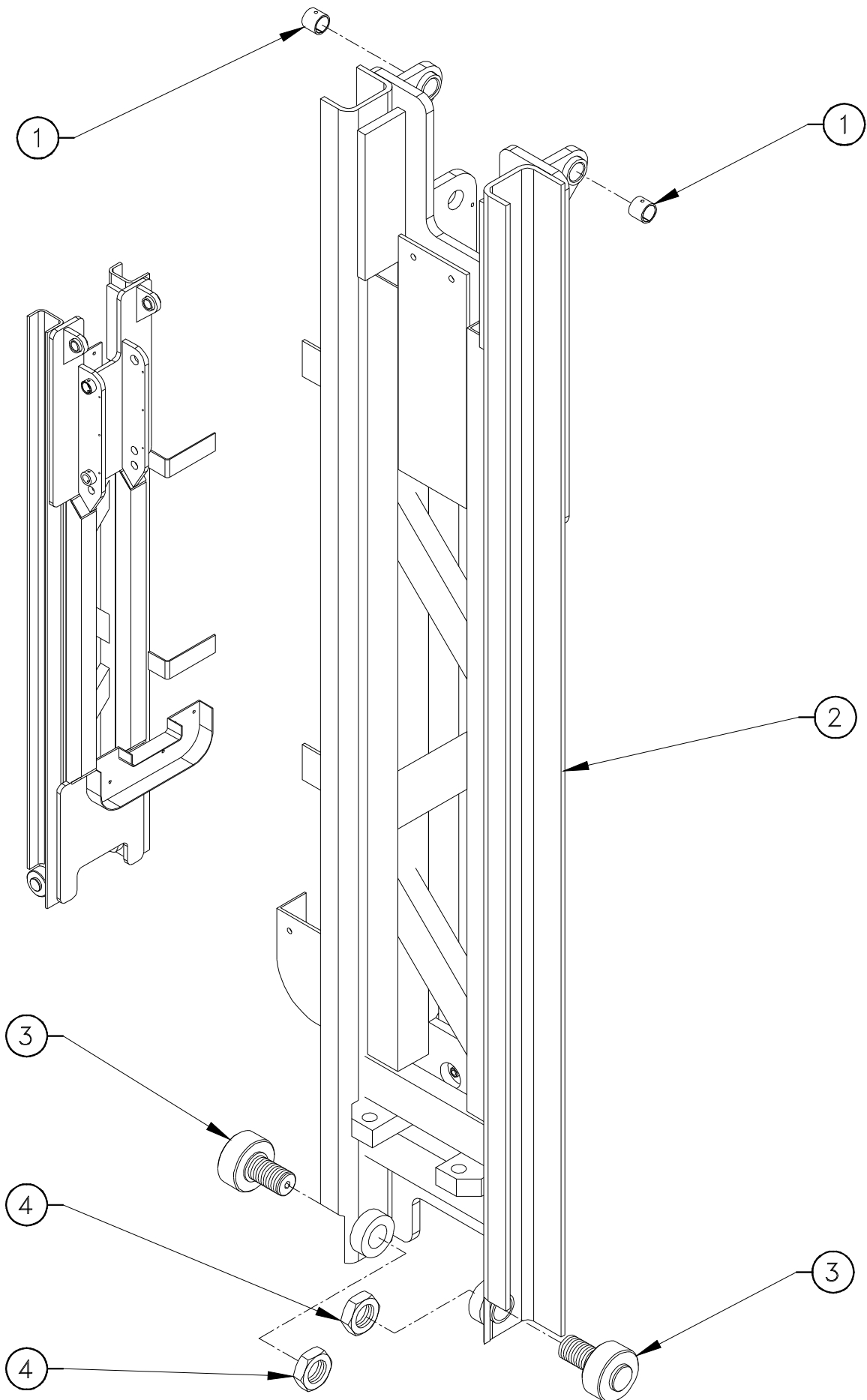

ROLLER ASSEMBLY GALET DE GUIDAGE ASSEMBLE

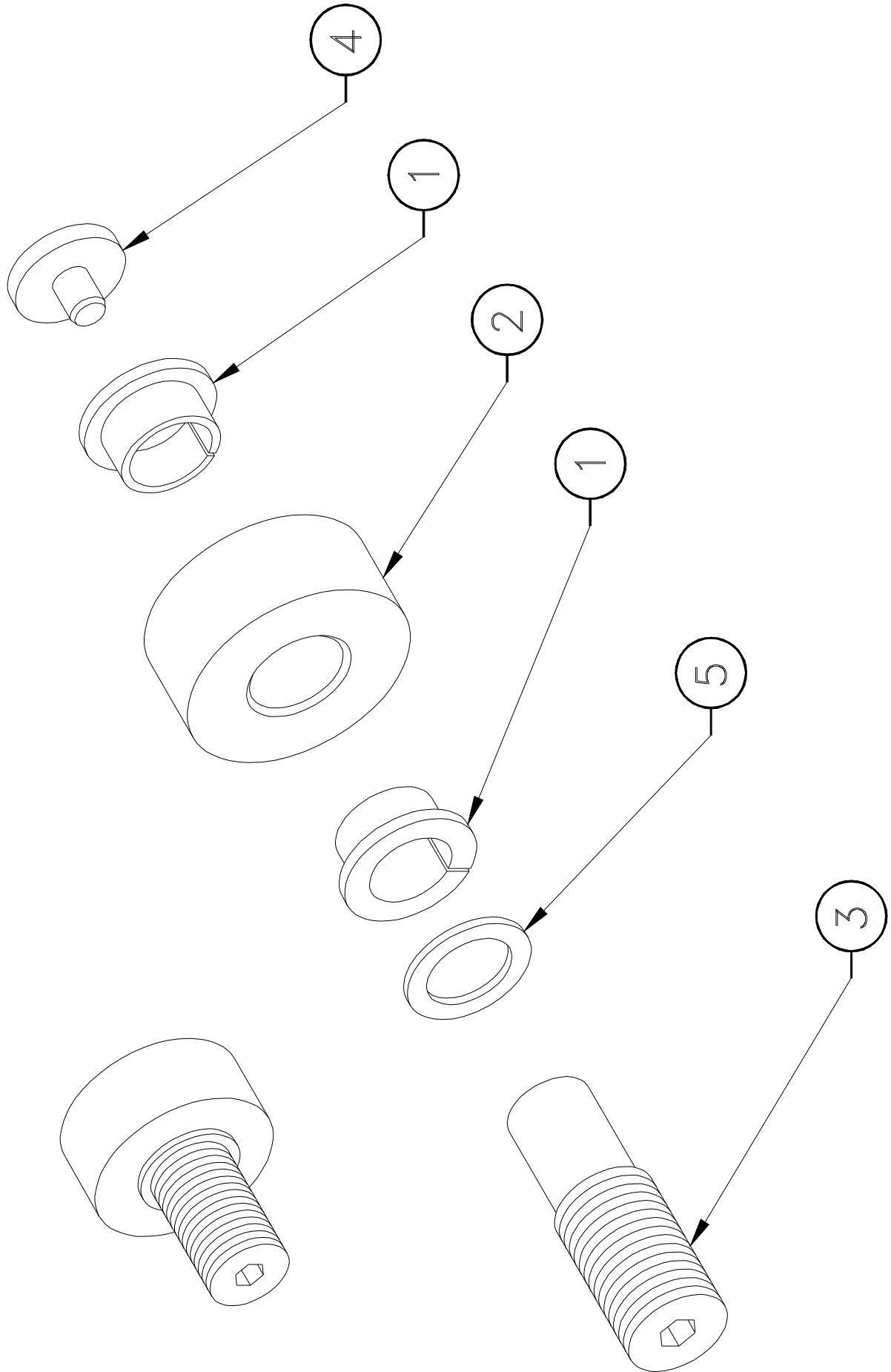

PULLEY ASSEMBLY ASSEMBLAGE SUPPORT POULIES

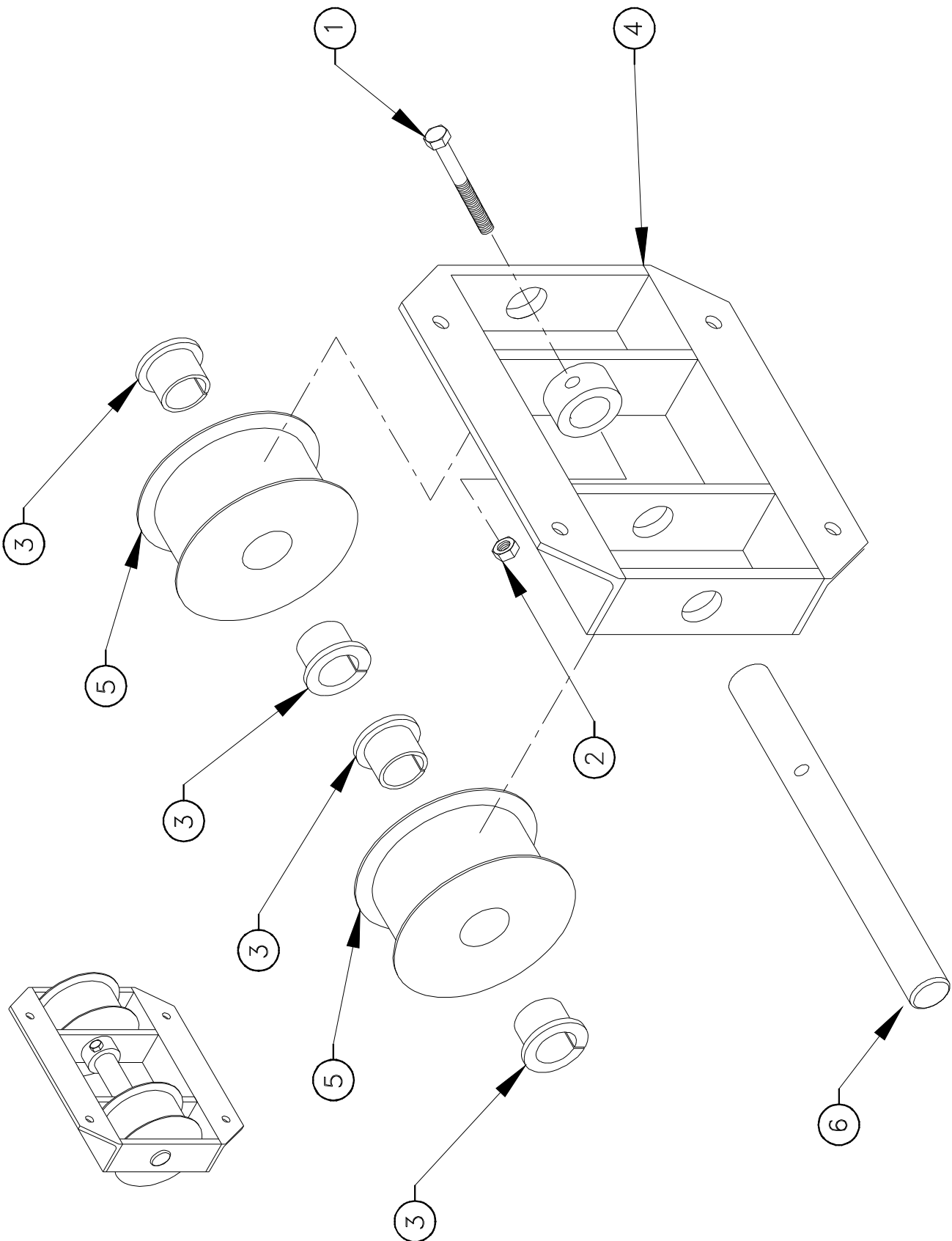

DATE : 10/12/97

PULLEY ASSEMBLY

MONTAGE N°/

ASSY NO : SP1048 REV :

ASSEMBLAGE SUPPORT POULIES

1/1

DET NO.	REF./PART NUMBER	VOIR/ SEE VIEW	DESCRIPTION		R E V	Qté/ Qty Req.
1	100013		M06x50 8.8 HEX HEAD CAPSCREW	VIS H M06x50 8.8 BI FP		1
2	110003		M06 GR. 8.8 LOCK NUT	ECROU FREIN M6 8.8 BI		1
3	150005		FLANGE BUSHING Ø25 H21.5 DU	BAGUE EPAULEE Ø25 H21.5 DU		4
4	ST0769		PULLEY MOUNT	SUPPORT POULIES		1
5	US0477		PULLEY	POULIE		2
6	US0200		PULLEY PIN	AXE DE SUPPORT POULIES		1

PULLEY ASSEMBLY

ASSEMBLAGE SUPPORT POULIES

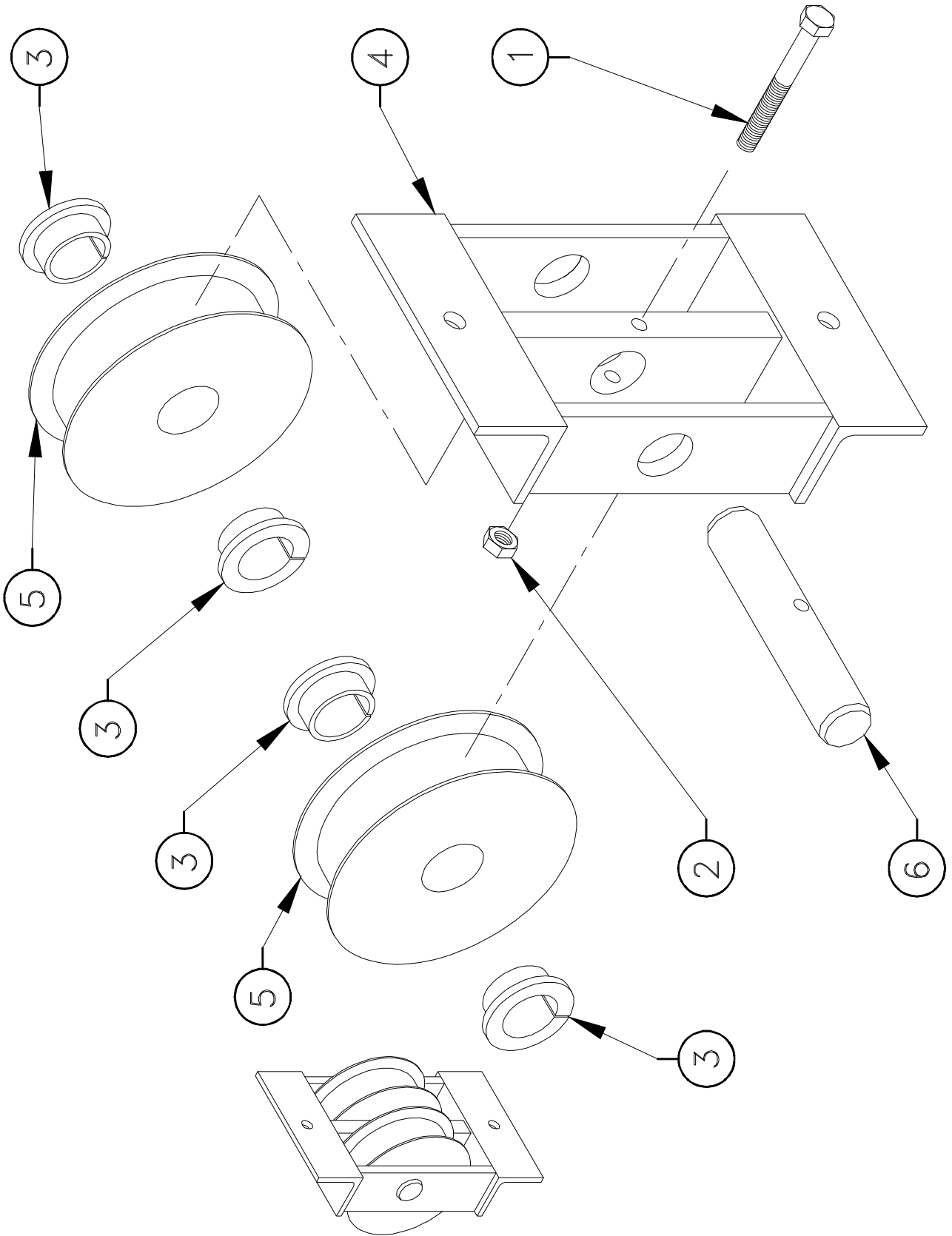

PULLEY ASSEMBLY ASSEMBLAGE SUPPORT POULIES

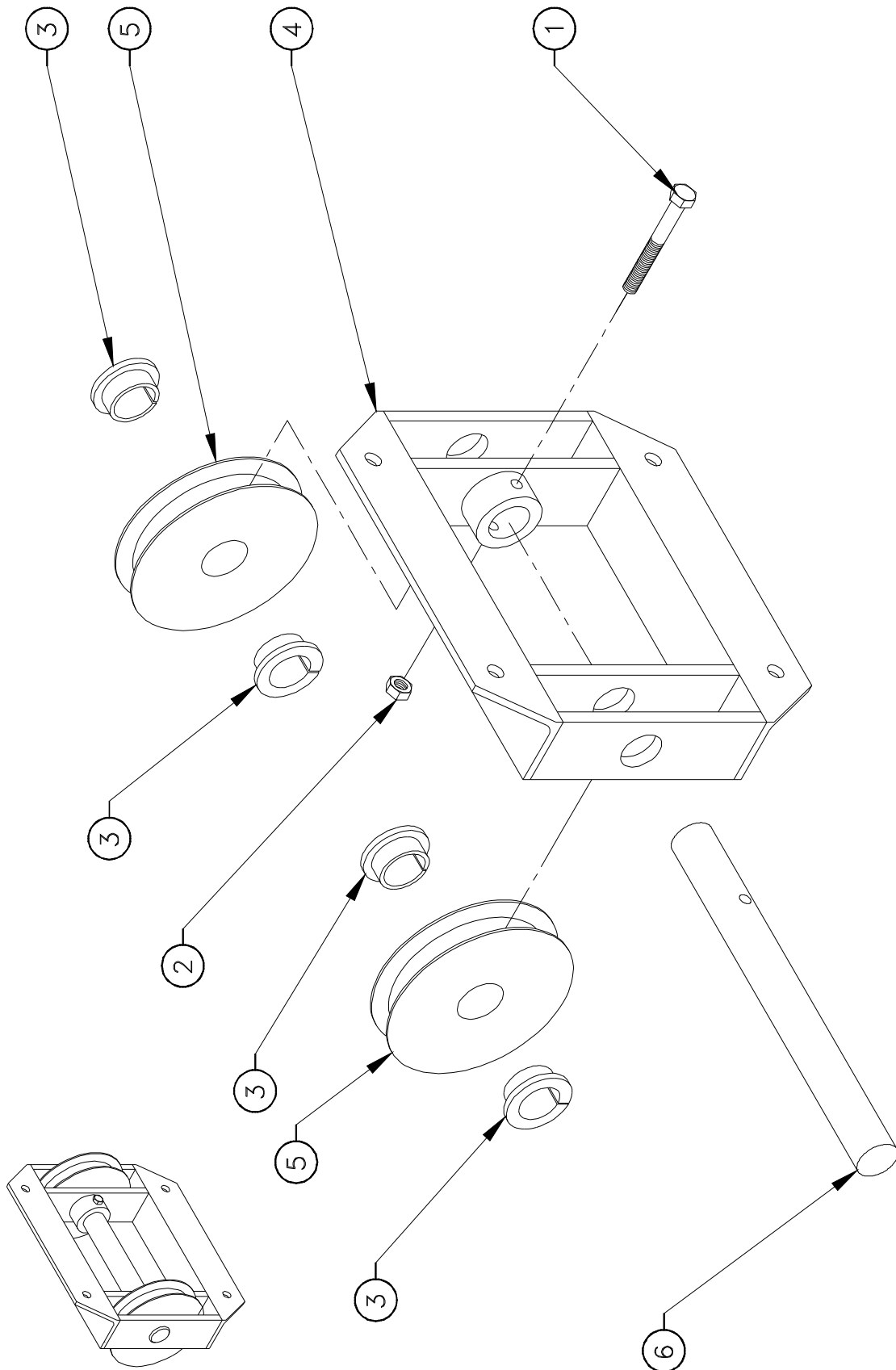

SPARE PARTS
PIECES DETACHEES

SECTION 8.

TURNTABLE INSTALL.
INSTALLATION TOURELLE.



TURNTABLE INSTALL INSTALLATION TOURELLE

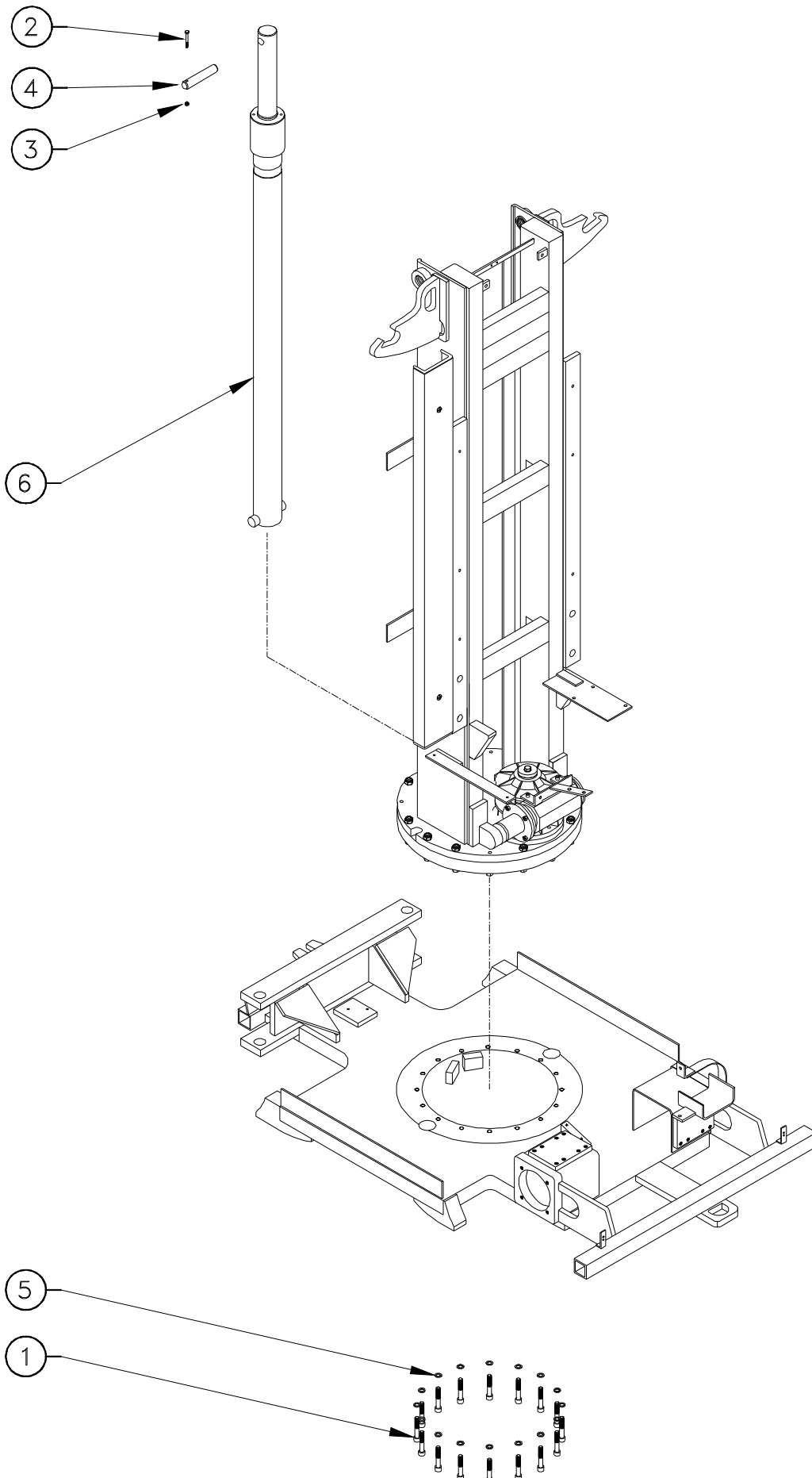

DATE : 11/12/97

TURNTABLE INSTALL

MONTAGE N°/

ASSY NO : SP1133 REV :

INSTALLATION TOURELLE

DET NO.	REF./PART NUMBER	VOIR/ SEE VIEW	DESCRIPTION		R E V	Qté/ Qty Req.
1	000041		M12x65 10.9 SOCKET HEAD C.SCR black	VIS CHC M12x65 10.9 BR FP		16
2	100137		M06x50 8.8 HEX HEAD MACHINE SCREW	VIS H M06x50 8.8 BI FT		1
3	110003		M06 GR. 8.8 LOCK NUT	ECROU FREIN M6 8.8 BI		1
4	US0128		MAST CYLINDER PIN	AXE VERIN		1
5	US0190		dDH 13x20x02 HEAT TREATED WASHER	RONDELLE TRAITEE dDH 13x20x02		16
6		APPENDIX A	MAST CYLINDER	VERIN DE MAT		1

SPARE PARTS
PIECES DETACHEES

SECTION 9.

FRAME INSTALL.
INSTALLATION CHASSIS.



FRAME INSTALL INSTALLATION CHASSIS

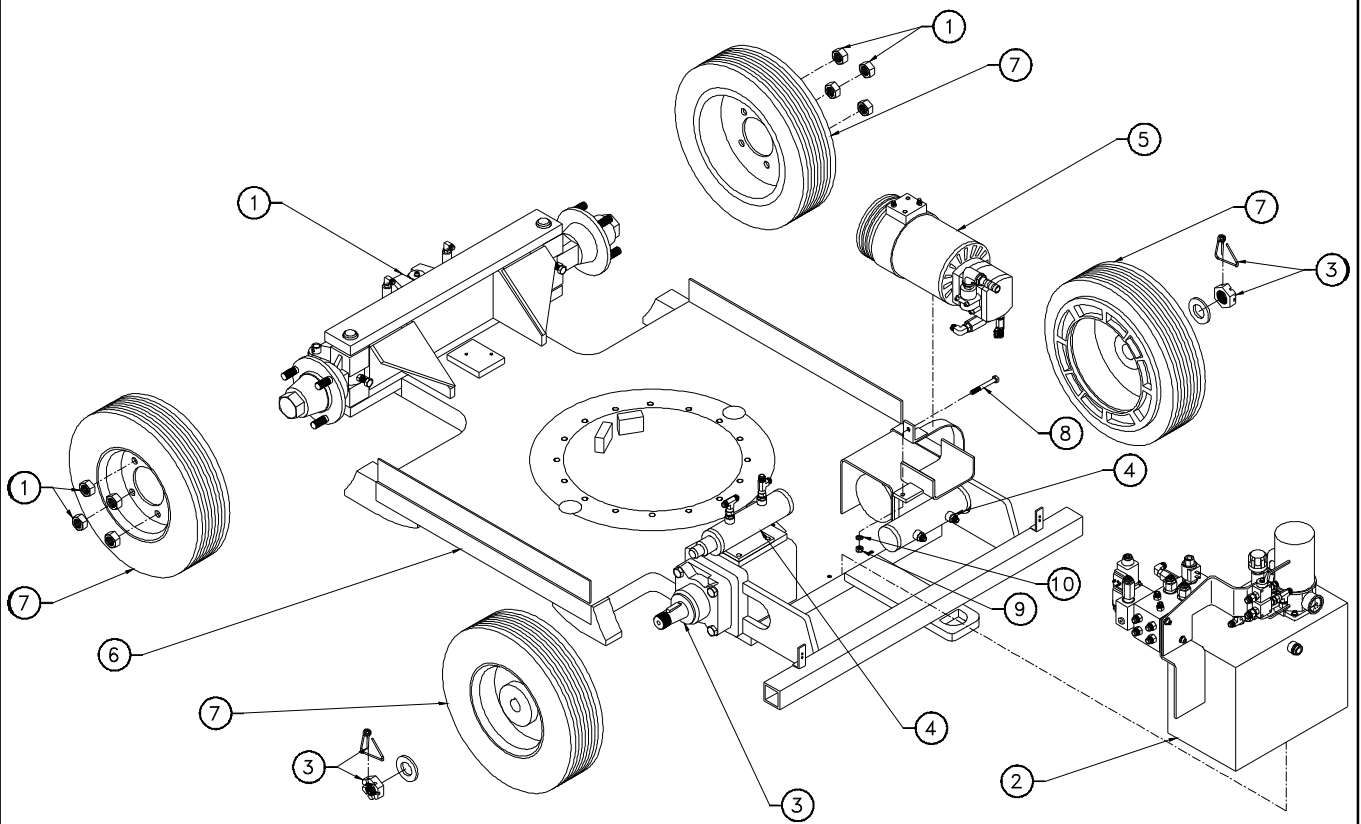

STEERING INSTALL INSTALLATION DE LA DIRECTION

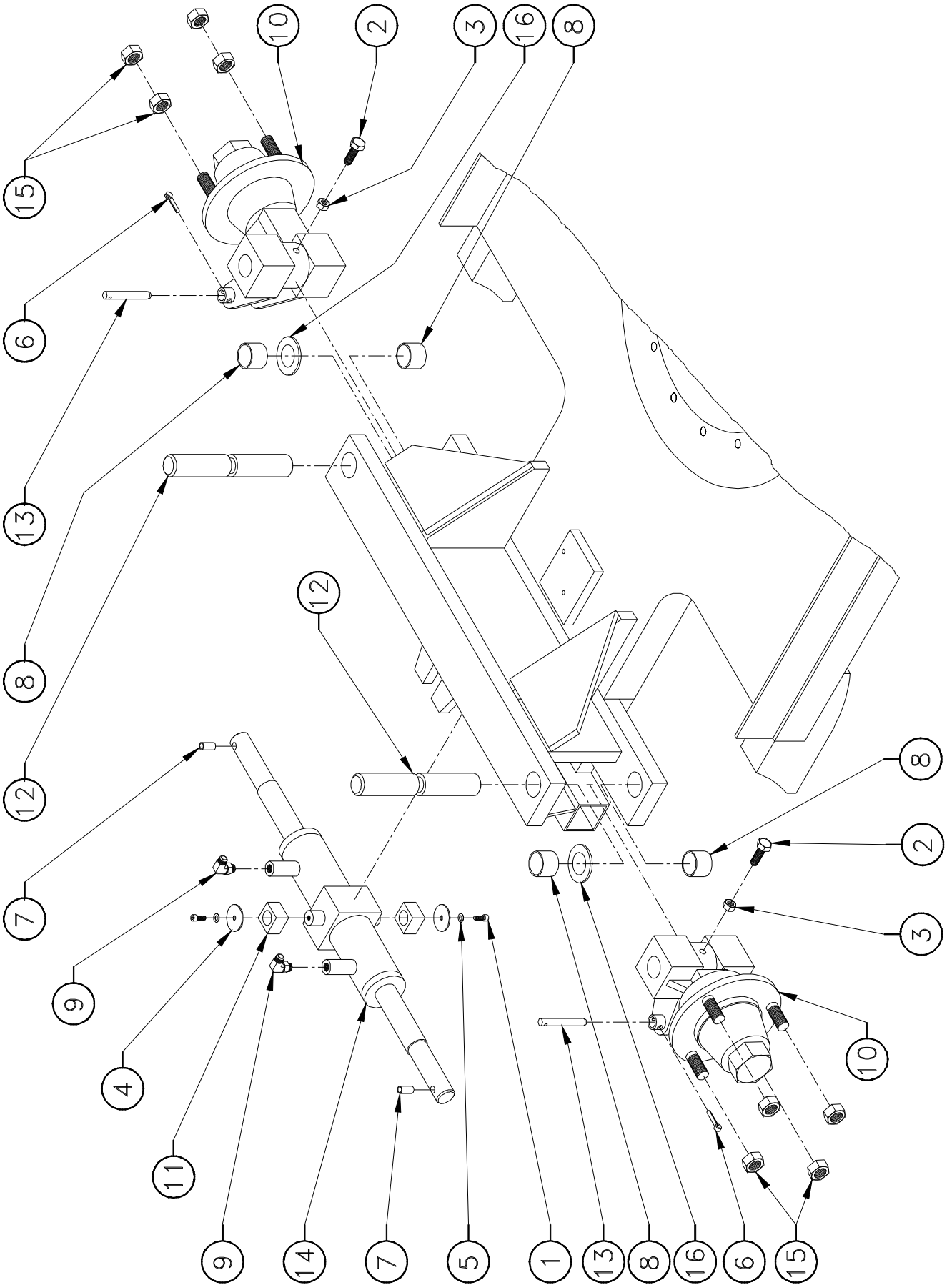

HYDRAULIC RESERVOIR INSTALL INSTALLATION DU RESERVOIR

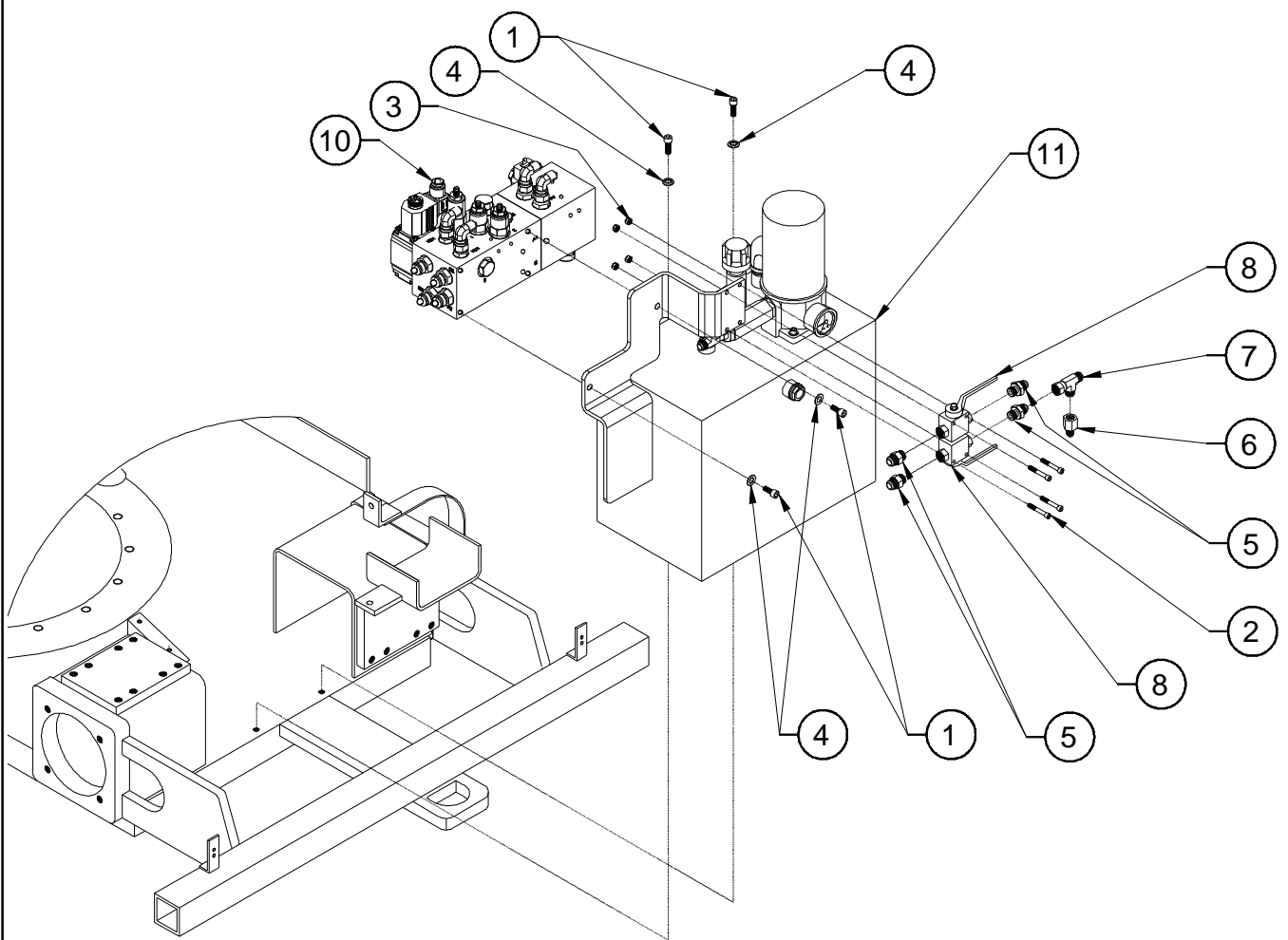

DATE : 18/06/02

HYDRAULIC RESERVOIR INSTALL

MONTAGE N°/

ASSY NO : SP0208 REV : A

INSTALLATION DU RESERVOIR

1/1

DET NO.	REF./PART NUMBER	VOIR/ SEE VIEW	DESCRIPTION		REVISION	Qté/ Qty Req.
1	000006		M08x20 8.8 SOCKET HEAD MACH SCREW	VIS CHC M08x20 8.8 BI FT		4
2	000004		M04x35 8.8 SOCK. HEAD MACH. SCREW	VIS CHC M04x35 8.8 BI FT	A	4
3	110001		M04 GR. 8.8 LOCK NUT	ECROU FREIN M4 8.8 BI	A	4
4	120010		dD 08x18 LOCK WASHER	RONDELLE CONTACT dD 08x18 BI		4
5	300025		FITTING MALE BSPP1/4-MALE JIC9/16	RACCORD MALE BSPP1/4-MALE JIC9/16		4
6	300030		ADAPTER FEMALE JIC9/16-MALE JIC7/16	REDUC. FEMELLE JIC9/16-MALE JIC7/16		1
7	300037		RUN TEE JIC 9/16 SWIVEL NUT	TE MALE JIC9/16-FEMELLE JIC9/16 TOUR.		1
8	310040		2-WAY GATE VALVE	VANNE 2 VOIES		2
9	ST1369		GATE VALVE SUPPORT	SUPPORT VANNE		1
10	SP0729	SP0729	DRIVE MANIFOLD ASSEMBLY	ASSEMBLAGE BLOC TRANSLATION	A	1
11		SP0244	HYDRAULIC RESERVOIR ASSEMBLY	ASSEMBLAGE DU RESERVOIR		1

DRIVE VALVE ASSEMBLY ASSEMBLAGE BLOC FORE

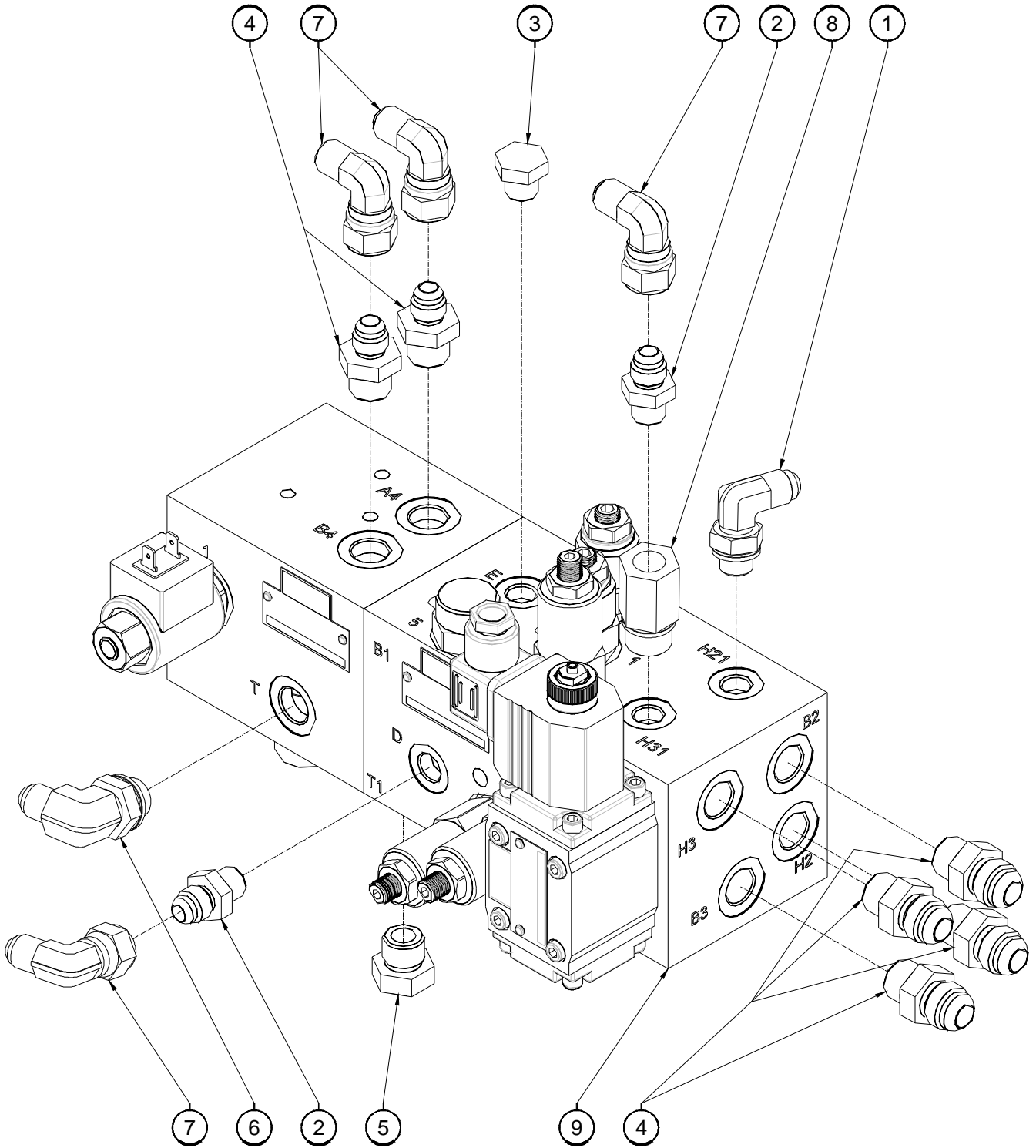

ISSUE DATE : 17/06/02

DRIVE MANIFOLD ASSEMBLY

ISSUE REL :

ASSEMBLY N° :
 N° ENSEMBLE :

SP0729 REV :

ASSEMBLAGE BLOC TRANSLATION

1/1

DET REP	PART NUMBER REF.	SEE VIEW VOIR VUE	DESCRIPTION		R E V	QTY QTE
1	300001		90° ELBOW MALE BSPP 1/4-MALE JIC 9/16	COUDE 90° Male BSPP 1/4 -Male JIC 9/16		1
2	300025		FITTING MALE BSPP1/4-MALE JIC9/16	RACCORD MALE BSPP1/4-MALE JIC9/16		2
3	300034		PLUG MALE BSPP 1/4	BOUCHON MALE BSPP 1/4		1
4	300040		FITTING MALE BSPP3/8 MALE JIC9/16	RACCORD MALE BSPP3/8 MALE JIC9/16		6
5	300047		PLUG BSPP 3/8	BOUCHON BSPP 3/8		1
6	300061		90° ELBOW MALE BSPP 3/8-MALE JIC 9/16	COUDE 90° MALE BSPP3/8-MALE JIC9/16		1
7	300067		90° ELBOW M JIC9/16 F JIC9/16 SWIVEL	COUDE Male JIC9/16 Fem JIC9/16 Tournant		4
8	300150		1/4 BSPP SPACER	ENTRETOISE 1/4 BSPP		1
9	952074	952074	DRIVE MANIFOLD	BLOC FORE DE TRANSLATION		1

DATE : 15/05/01

DRIVE MANIFOLD

MONTAGE N°/

ASSY NO : 952074 REV :

BLOC FORE DE TRANSLATION

1/1

DET NO.	REF./PART NUMBER	VOIR/SEE VIEW	DESCRIPTION		REV	Qté/Qty Req.
1		952073	2 SPEED MANIFOLD	BLOC 2 VITESSES		1
2		952040	3rd SPEED MANIFOLD	BLOC 3° VITESSE		1

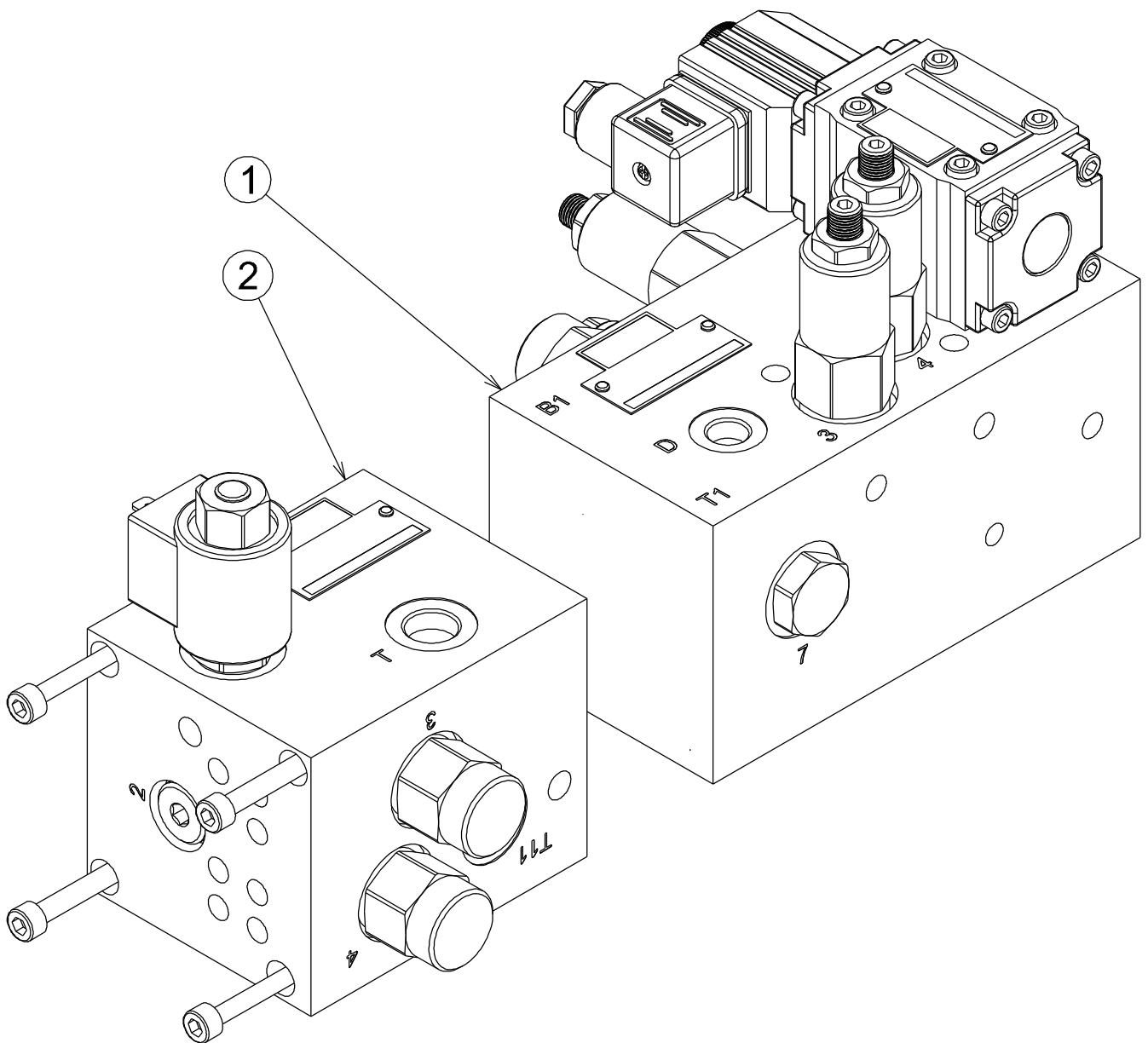

DATE : 03/07/02

2 SPEED MANIFOLD

MONTAGE N°/
 ASSY NO : 952073 REV :

BLOC 2 VITESSES

1/1

DET NO.	REF./PART NUMBER	VOIR/ SEE VIEW	DESCRIPTION		R E V	Qté/ Qty Req.
1	900050		PRESSURE REDUCER SEAL KIT	KIT DE JOINT REDUCTEUR DE PRESSION		1
2	900068		SHUTTLE VALVE	SELECTEUR DE CIRCUIT		1
3	900070		SEAL KIT	KIT DE JOINTS		1
4	900115		COUNTER BALANCE VALVE	VALVE D'EQUILIBRAGE		2
5	952045		PRESSURE RELIEF VALVE	LIMITEUR DE PRESSION		2
6	900066		CHECK VALVE	CLAPET ANTI-RETOUR		1
7	952047		CHECK VALVE JET	CLAPET GICLE		1
8	952048		HIGH SPEED ENABLE VALVE	DISTRIBUTEUR GRANDE VITESSE		1
9	952049		VALVE COIL	BOBINE DISTRIBUTEUR		1
10	960006		COUNTER BALANCE VALVE SEAL KIT	JEU DE JOINTS VALVE D'EQUILIBRAGE		2
11	952075		PRESSURE RELIEF VALVE	LIMITEUR DE PRESSION		1
12	300138		PLUG UNF 3/4x16	BOUCHON UNF 3/4x16		1

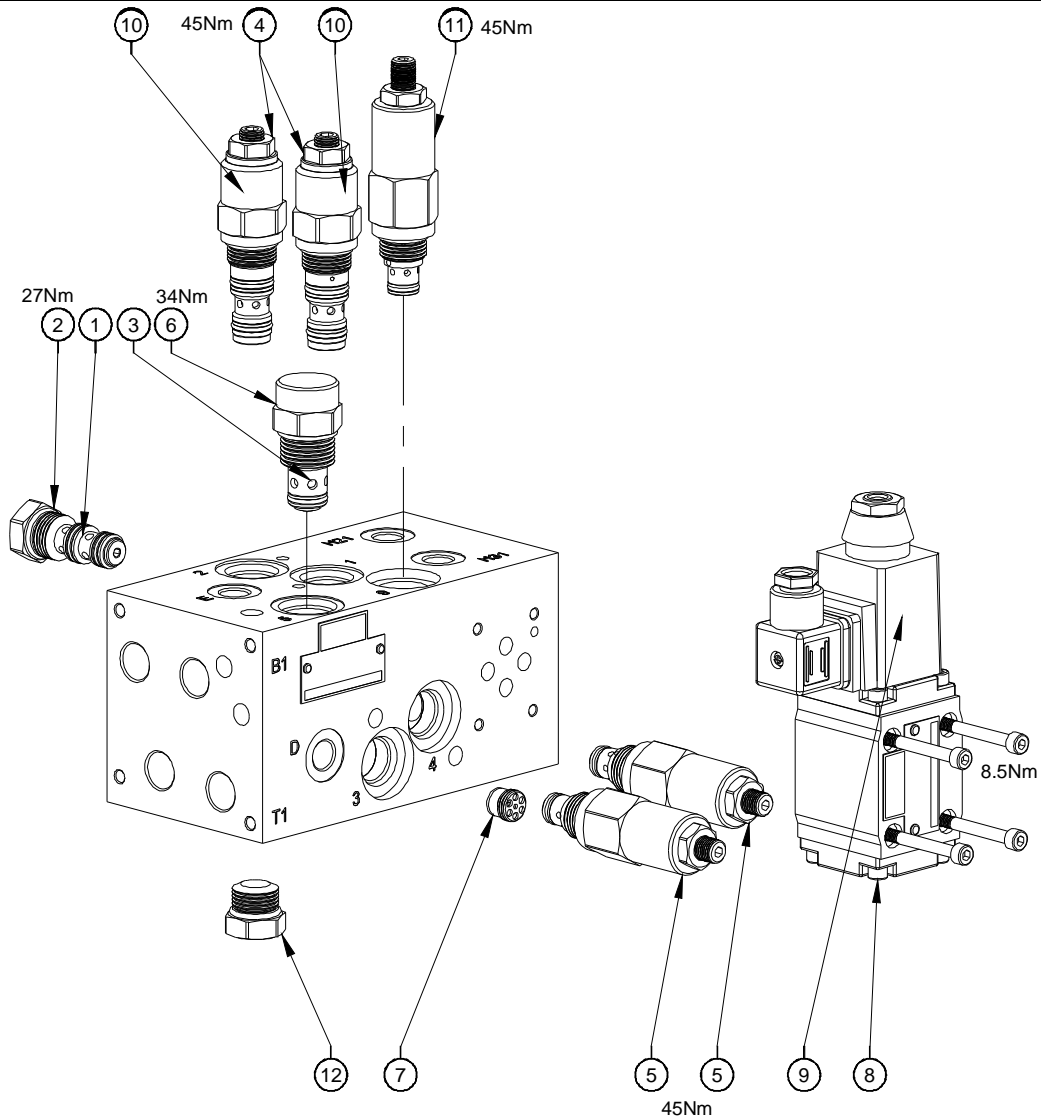

DATE : 15/05/01

3rd SPEED MANIFOLD

MONTAGE N°/

ASSY NO : 952040 REV :

BLOC 3° VITESSE

1/1

DET NO.	REF./PART NUMBER	VOIR/ SEE VIEW	DESCRIPTION		R E V	Qté/ Qty Req.
1	900077		SEAL KIT	KIT DE JOINTS		1
2	900108		CARTRIDGE SEALS PV7033	JOINTS CARTOUCHE PV7033		2
3	900109		LOW SPEED DISABLE VALVE	ELECTRO. COUPURE PETITE VITESSE		1
4	952037		HI-LO VALVE COIL	BOBINE ELECTRO CLAPET		1
5	952052	<11/2002	Ø 1.8 JET	GICLEUR Ø 1.8		1
5	920024	>11/2002	Ø 1.6 JET	GICLEUR Ø 1.6		1
6	952053		COMMUTATION VALVE	VALVE DE COMMUTATION		2
7			M06x100 12.9 SOCKET HEAD CAPSCREW	VIS CHC M06x100 12.9 BI FP		4
8			O RING 1.78x18.77	JOINT TORIQUE 1.78x18.77		4

SEE SERVICE MANUAL WHEN CHANGING ITEM 5.
VOIR MANUEL DE SERVICE QUAND ON CHANGE LE REPERE 5.

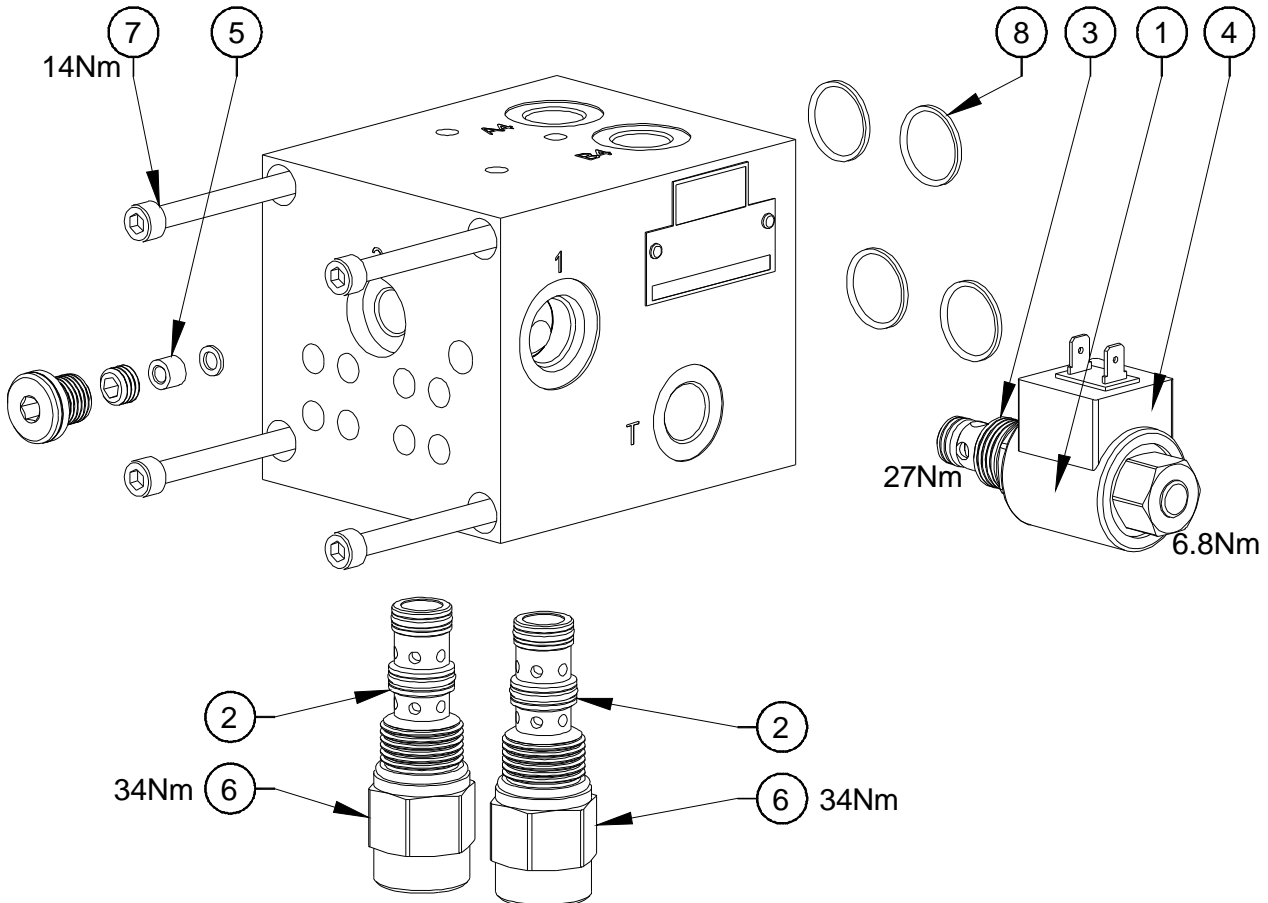

HYDRAULIC RESERVOIR ASSEMBLY ASSEMBLAGE DU RESERVOIR

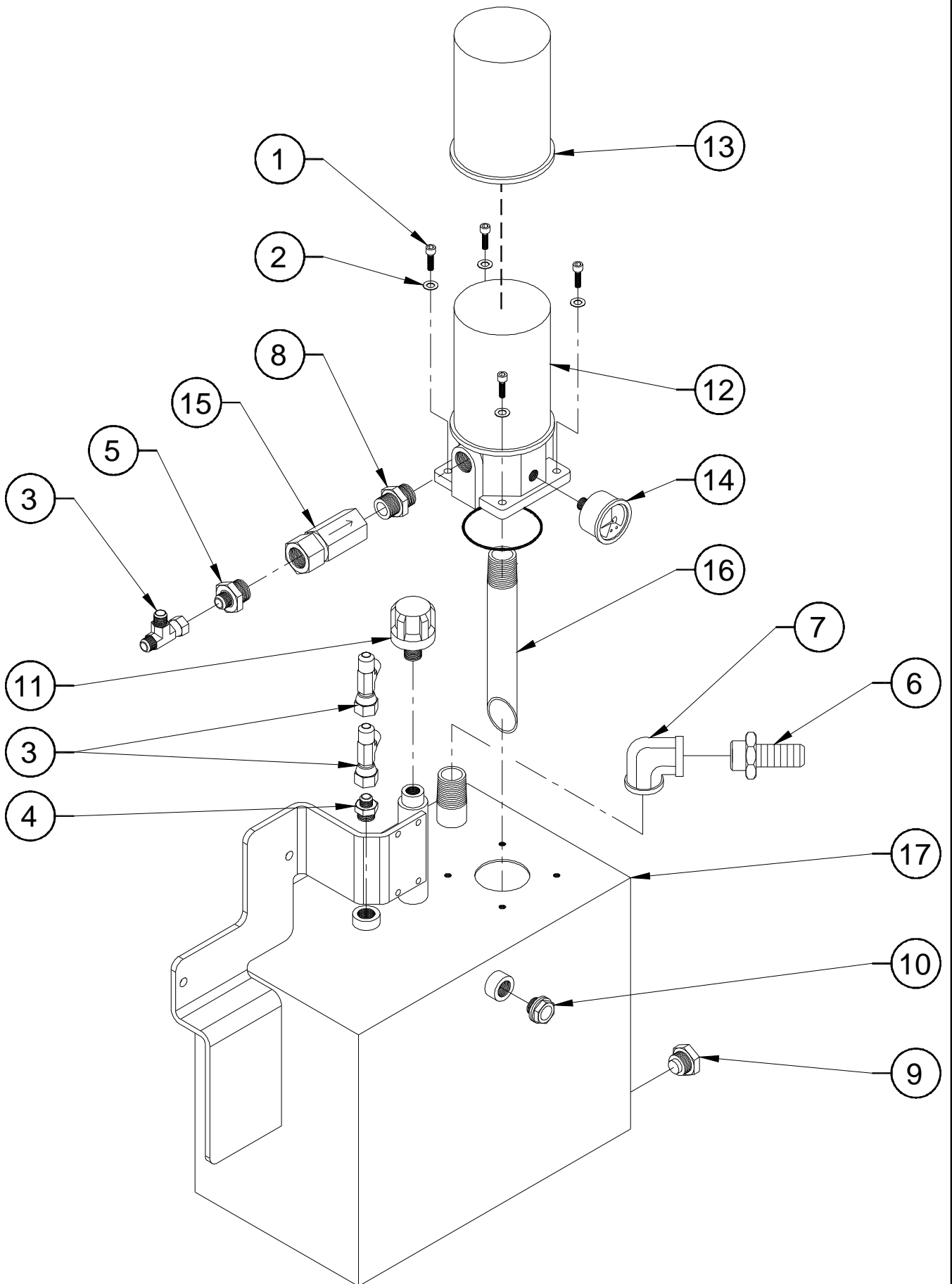

HYDRAULIC DRIVE MOTORS INSTALL INSTALLATION DES MOTEURS DE ROUES

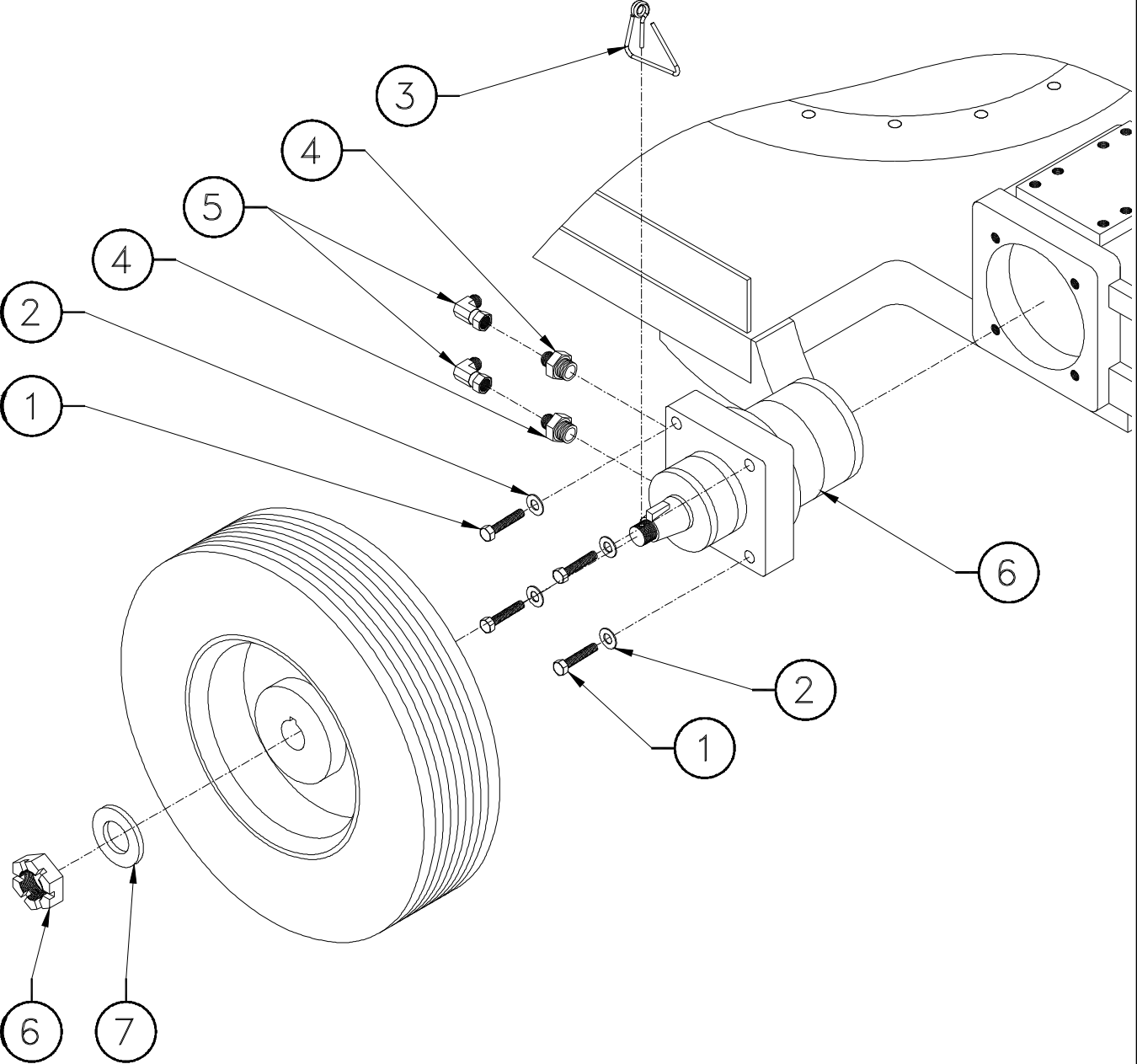

BRAKE CYLINDERS INSTALL INSTALLATION DES VERINS FREINS

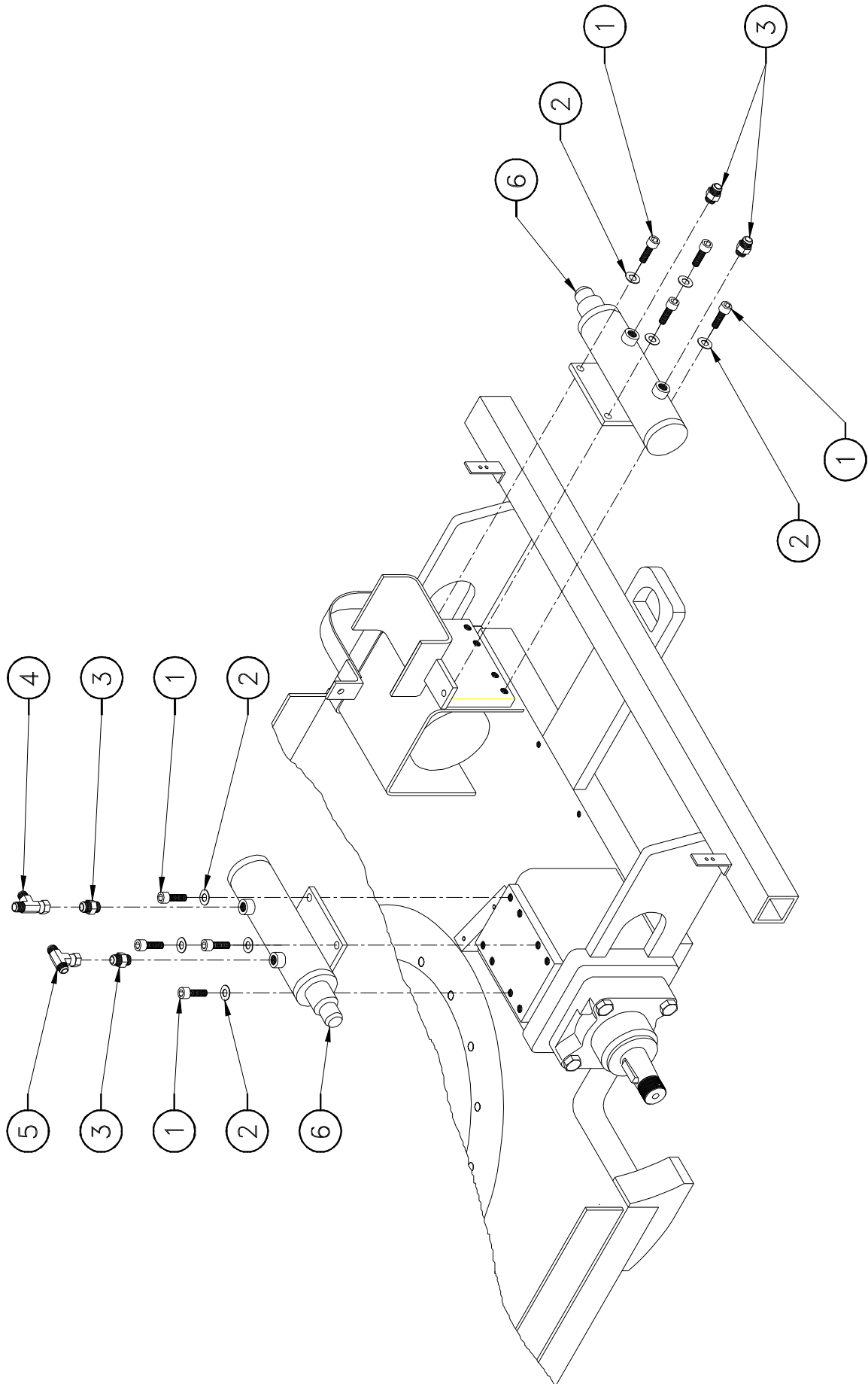

DATE : 23/12/97

BRAKE CYLINDER INSTALL

MONTAGE N°/
ASSY NO : SP0215 REV :

INSTALLATION DES VERIN FREINS

1/1

DET NO.	REF./PART NUMBER	VOIR/ SEE VIEW	DESCRIPTION		R E V	Qté/ Qty Req.
1	000028		M10x20 8.8 SOCKET HEAD MACH SCREW	VIS CHC M10x20 8.8 BI FT		8
2	120011		dD 10x22 LOCK WASHER	RONDELLE CONTACT dD 10x22 BI		8
3	300025		FITTING MALE BSPP1/4-MALE JIC9/16	RACCORD MALE BSPP1/4-MALE JIC9/16		4
4	300037		RUN TEE JIC 9/16 SWIVEL NUT	TE MALE JIC9/16-FEMELLE JIC9/16 TOUR.		1
5	300055		BRANCH TEE JIC 9/16 SWIVEL NUT	TE Male JIC9/16-Fem JIC9/16 TOUR.CEN.		1
6		APPENDIX A	VERIN FREIN	BRAKE CYLINDER		2

POWER UNIT INSTALL INSTALLATION DE LA CENTRALE

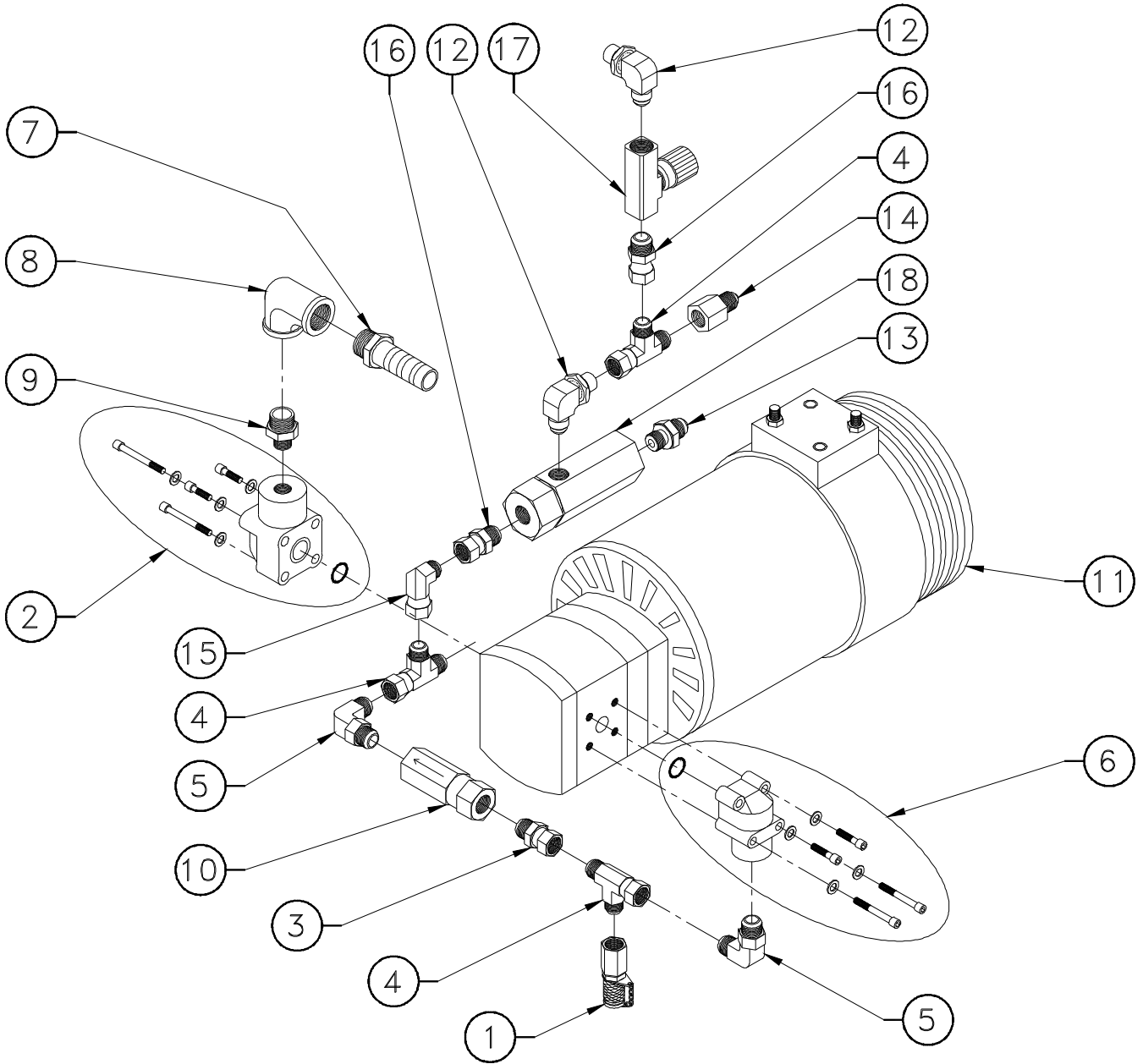

DATE : 18/05/99

PUMP/MOTOR INSTALL

MONTAGE N°/

ASSY NO : SP0218 REV : A

INSTALLATION DE LA CENTRALE

1/1

DET NO.	REF./PART NUMBER	VOIR/SEE VIEW	DESCRIPTION		R E V	Qté/ Qty Req.
1	300004		PRESSURE TEST PLUG JIC9/16 SMK	PRISE DE PRESSION JIC 9/16 SMK		1
2	300015		90° PUMP FLANGE ELBOW Ø40 BSPP 1/2	BRIDE POMPE Ø40 COUDE 90° BSPP 1/2		1
3	300027		FITTI. MALE BSPP3/8-FEM.JIC9/16 SWIVE	UNION MALE BSPP 3/8 -TOUR. JIC 9/16		1
4	300037		RUN TEE JIC 9/16 SWIVEL NUT	TE MALE JIC9/16-FEMELLE JIC9/16 TOUR.	A	3
5	300061		90° ELBOW MALE BSPP 3/8-MALE JIC 9/1	COUDE 90° MALE BSPP3/8-MALE JIC9/16		2
6	300068		90° PUMP FLANGE ELBOW Ø35 BSPP 3/8	BRIDE POMPE Ø35 COUDE 90° BSPP 3/8		1
7	300078		FITTING Male BSPP3/4-Male Ø19 GROOVE	RACCORD Male BSPP3/4-Ø19 CANNELE		1
8	300079		90° ELBOW FEM. BSPP 3/4	COUDE FEMELLE BSPP 3/4		1
9	300080		REDUCTION Male BSPT1/2-Male BSPT3/4	REDUCTION Male BSPT1/2-Male BSPT3/4		1
10	310020		CHECK VALVE 0.5 BAR BSPP 3/8	CLAPET ANTI RETOUR 0.5 BAR BSPP 3/8		1
11	520014	520014	5.5cc/rev POWER UNIT	CENTRALE 5.5cm³/tr		1
12	300001		90° ELBOW MALE BSPP 1/4-MALE JIC 9/1	COUDE 90° Male BSPP 1/4 -Male JIC 9/16	A	2
13	300025		FITTING MALE BSPP1/4-MALE JIC9/16	RACCORD MALE BSPP1/4-MALE JIC9/16	A	1
14	300030		ADAPTER FEMALE JIC9/16-MALE JIC7/16	REDUC. FEMELLE JIC9/16-MALEJIC7/16	A	1
15	300067		90° ELBOW M JIC9/16 F JIC9/16 SWIVEL	COUDE Male JIC9/16 Fem JIC9/16 Tournant	A	1
16	300073		FITTING MALE BSPP 1/4-FEMALE JIC 9/16	RACC. MALE BSPP 1/4 -FEM. JIC 9/16	A	2
17	310017		FLOW CONTROL VALVE	REGULATEUR DE DEBIT	A	1
18	320001		PILOT CHECK VALVE	CLAPET ANTI RETOUR PILOTE	A	1

DATE : 23/12/97

5.5cc/rev POWER UNIT

MONTAGE N°/
ASSY NO : 520014 REV : A

CENTRALE 5.5cm³/t

1/1

DET NO.	REF./PART NUMBER	VOIR/SEE VIEW	DESCRIPTION		REV	Qté/Qty Req.
1	940013		DC MOTOR	MOTEUR A COURANT CONTINU		1
2	900058	900058	5.5 cc/rev PUMP	POMPE 5.5 cm ³ /t		1
3	900005		BRUSH KIT (QUANTITY : 4)	JEU DE 4 BALAIS		1
4	940032		SPRING KIT (QUANTITY : 4)	JEU DE 4 RESSORTS	A	1

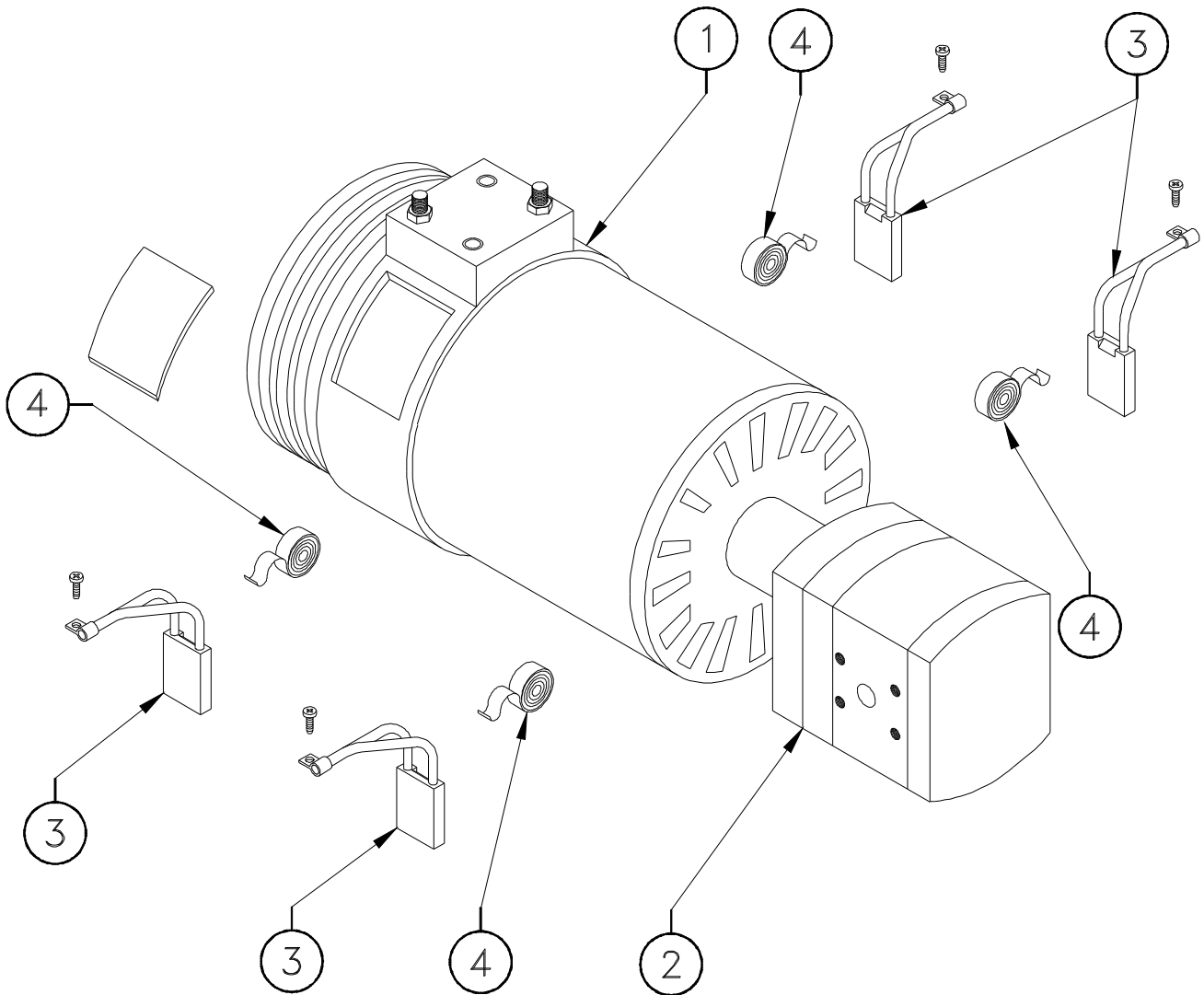

5.5 cc/rev PUMP
POMPE 5.5 cm³/t

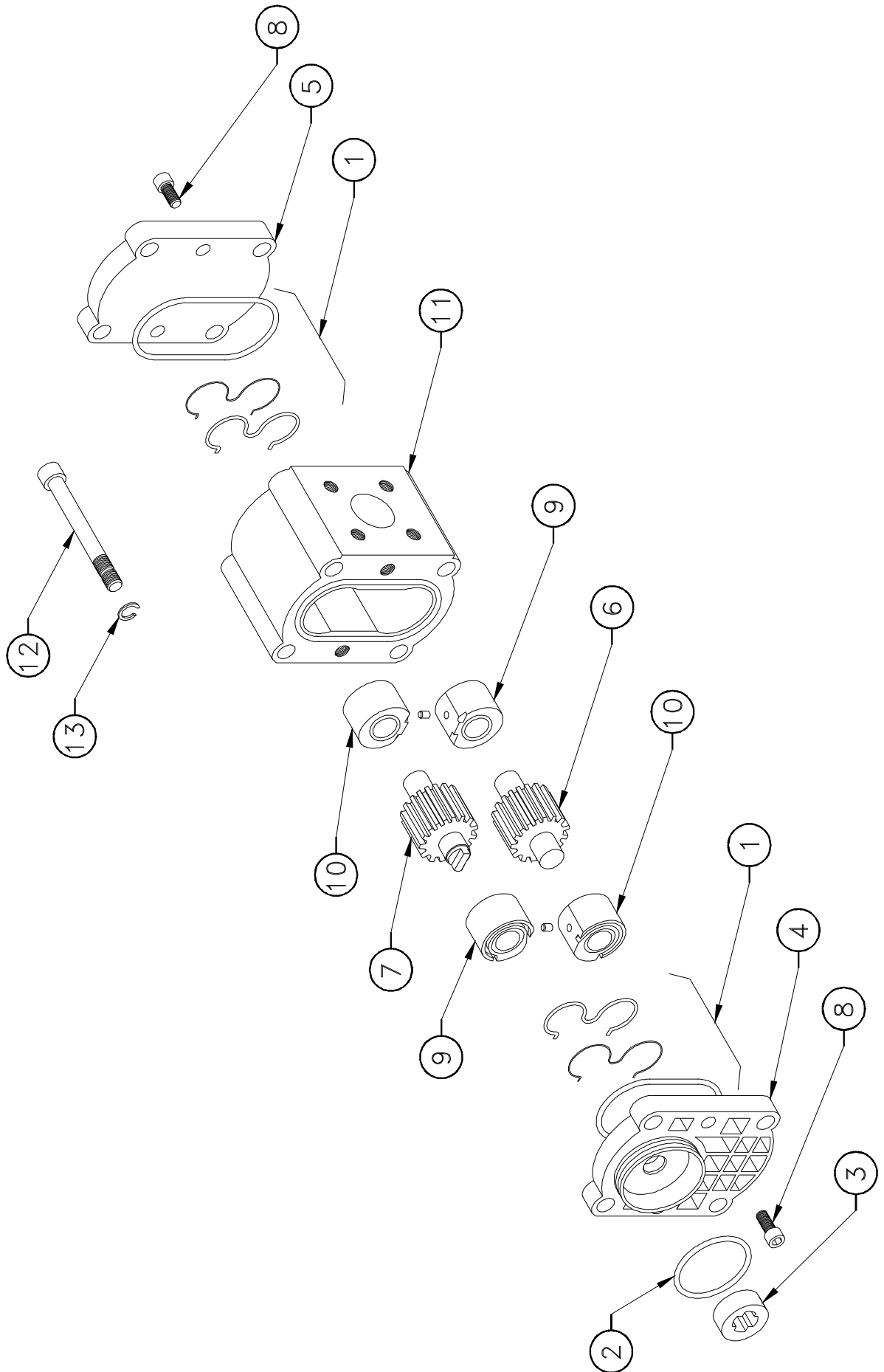

DATE : 17/03/97

5.5 cc/rev PUMP

MONTAGE N°/ ASSY NO : 900058 REV :

POMPE 5.5 cm³/t

1/1

DET NO.	REF./PART NUMBER	VOIR/ SEE VIEW	DESCRIPTION		RE V	Qté/ Qty Req.
1	900021		SEAL KIT	KIT DE JOINTS		1
2	900045		O-RING	JOINT TORIQUE CENTRAL POMPE		1
3	940010		COUPLING	ACCOUPLLEMENT DE POMPE		1
4			PUMP END COVER	FLASQUE DE POMPE		1
5			PUMP END COVER	COUVERCLE DE POMPE		1
6			GEAR	PIGNON		1
7			DRIVE GEAR	PIGNON		1
8			M08x16 8.8 SPLIT CYLIND. HEAD CAPSC.	VIS CS M08x16 8.8 FP		8
9			BUSHING	PALIER		2
10			BUSHING	PALIER		2
11			5.5 cm ³ /rev GEAR HOUSING	CORPS DE POMPE		1
12			M10x80 8.8 SOCKET HEAD CAPSCREW	VIS CHC M10x80 8.8 BI FP		4
13			M08 WASHER	RONDELLE M08		4

SPARE PARTS
PIECES DETACHEES

SECTION 10.

MAST 1 ASSEMBLY.
ASSEMBLAGE MAT 1.



MAST 1 ASSEMBLY ASSEMBLAGE MAT 1

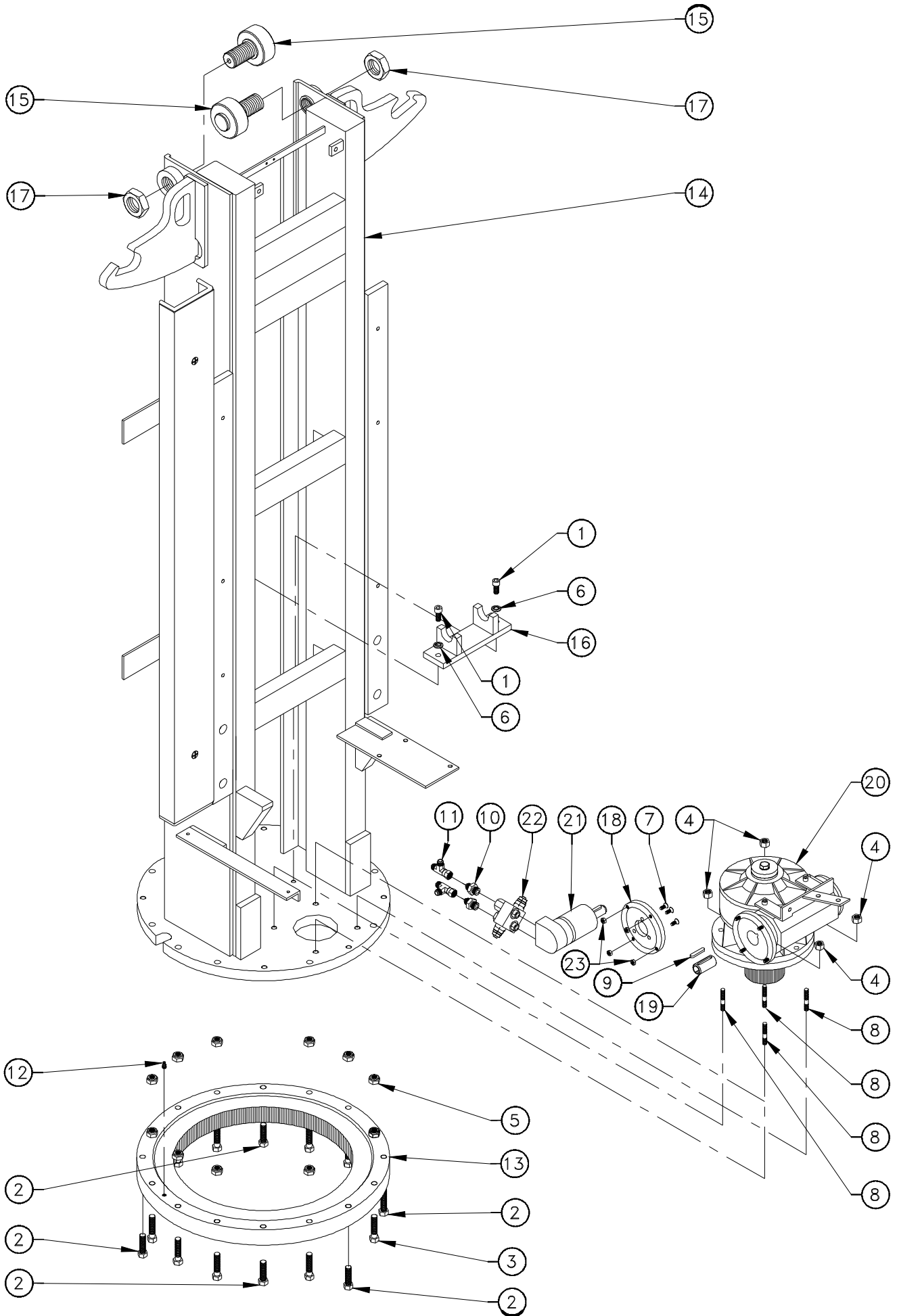

DATE : 11/10/02

MAST 1 ASSEMBLY

MONTAGE N°/

ASSY NO : SP0212 REV : B

ASSEMBLAGE MAT 1

1/1

DET NO.	REF./PART NUMBER	VOIR/ SEE VIEW	DESCRIPTION		REVISION	Qté/ Qty Req.
1	000019		M10x35 8.8 SOCKET HEAD MACH SCREW	VIS CHC M10x35 8.8 BI FT		2
2	100037		M12x60 10.9 HEX HEAD CAPSCREW Black	VIS H M12x60 10.9 BR FP		5
3	100038		M12x90 10.9 HEX HEAD CAPSCREW Black	VIS H M12x90 10.9 BR FP		11
4	110014		M12 GR. 8.8 LOCK NUT	ECROU FREIN M12 8.8 BI		4
5	110017		M12 GR. 10.9 LOCK NUT	ECROU FREIN H M12 10.9 BI		11
6	120011		dD 10x22 LOCK WASHER	RONDELLE CONTACT dD 10x22 BI		2
7	130003		M06x16 10.9 COUNTERSUNK HEAD M. S.	VIS FHC M06x16 10.9 BI FT		3
8	130005		M12x35 8.8 STUD. BLACK	GOUGEON M12x35 BR 8.8		4
9	140002		A KEY 8x6x40	CLAVETTE FORME A 8x6x40		1
10	300040		FITTING MALE BSPP3/8 MALE JIC9/16	RACCORD MALE BSPP3/8 MALE JIC9/16		2
11	300037		RUN TEE JIC 9/16 SWIVEL NUT	TE MALE JIC9/16-FEMELLE JIC9/16 TOUR.		2
12	310057		GREASE FITTING 1/8 BSPT	GRAISSEUR BSPT 1/8		1
13	500002		SWING RING	COURONNE D'ORIENTATION		1
14	SD0332		MAST 1	MAT 1		1
15	SE0495	SE0495	ROLLER ASSEMBLY	ASSEMBLAGE GALET DE GUIDAGE	A	2
16	ST0772		MAST CYLINDER SUPPORT	SUPPORT VERIN DE LEVAGE		1
17	US0026		M36 GR. 8.8 HEX NUT	ECROU M36 8.8		2
18	US0044		MOTOR ADAPTOR FLANGE	FLASQUE MOTEUR		1
19	US0045		COUPLING	ACCOUPEMENT		1
20	SP1105		SWING DRIVE ASSEMBLY	ASSEMBLAGE REDUCT. D'ORIENTATION		1
21		APPENDIX E	SWING MOTOR	MOTEUR D'ORIENTATION		1
22	310084		DOUBLE RELIEF VALVE MANIFOLD	BLOC LIMITEUR DOUBLE	B	1
23	110015		M06 GR. 8.8 HEX NUT	ECROU H M06 8.8 BI	A	4

SWING DRIVE ASSEMBLY ASSEMBLAGE MOTO-REDUCTEUR D'ORIENTATION

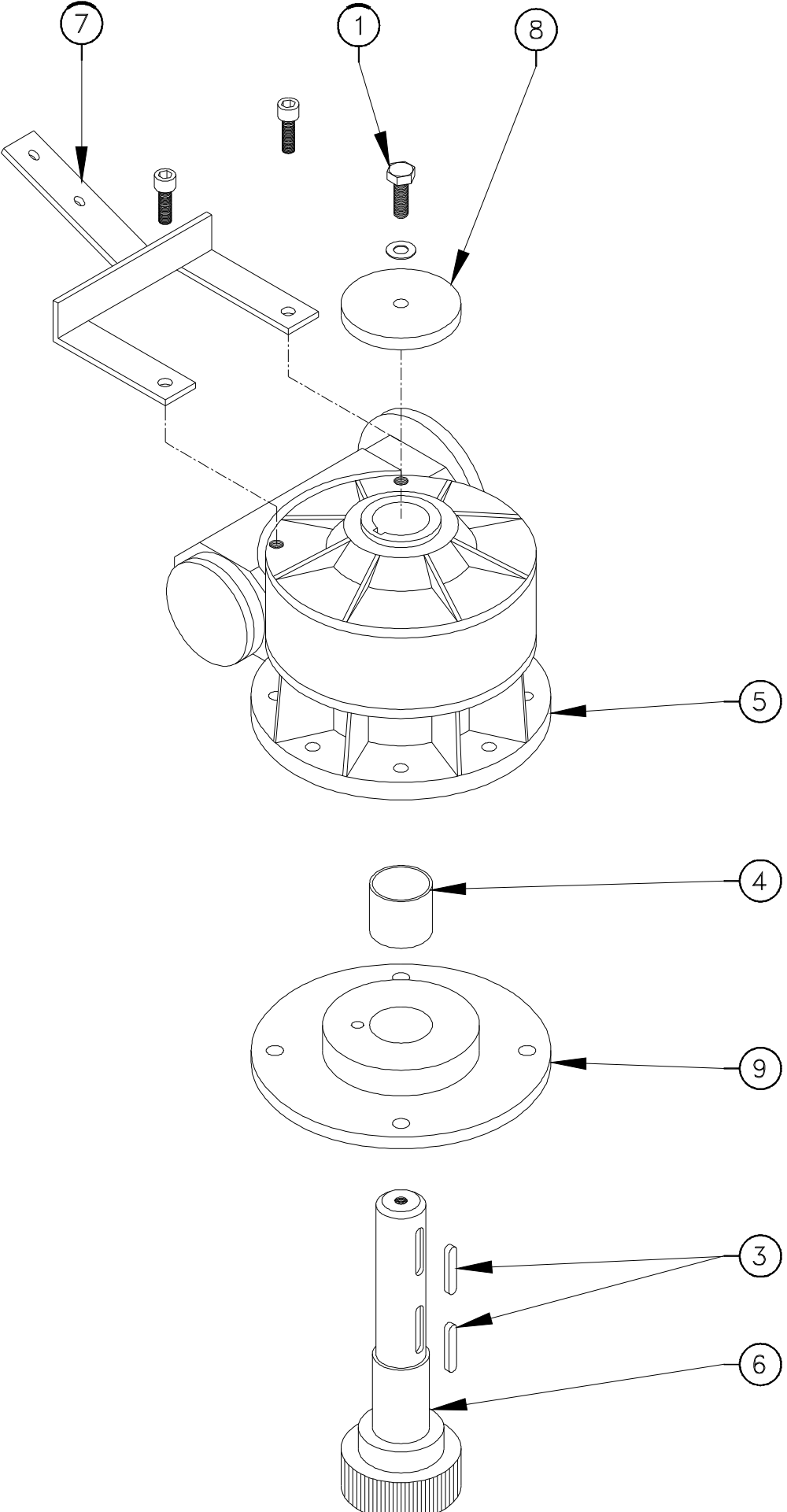

SPARE PARTS
PIECES DETACHEES

SECTION 11

JIB INSTALL
INSTALLATION BRAS



JIB INSTALL INSTALLATION BRAS

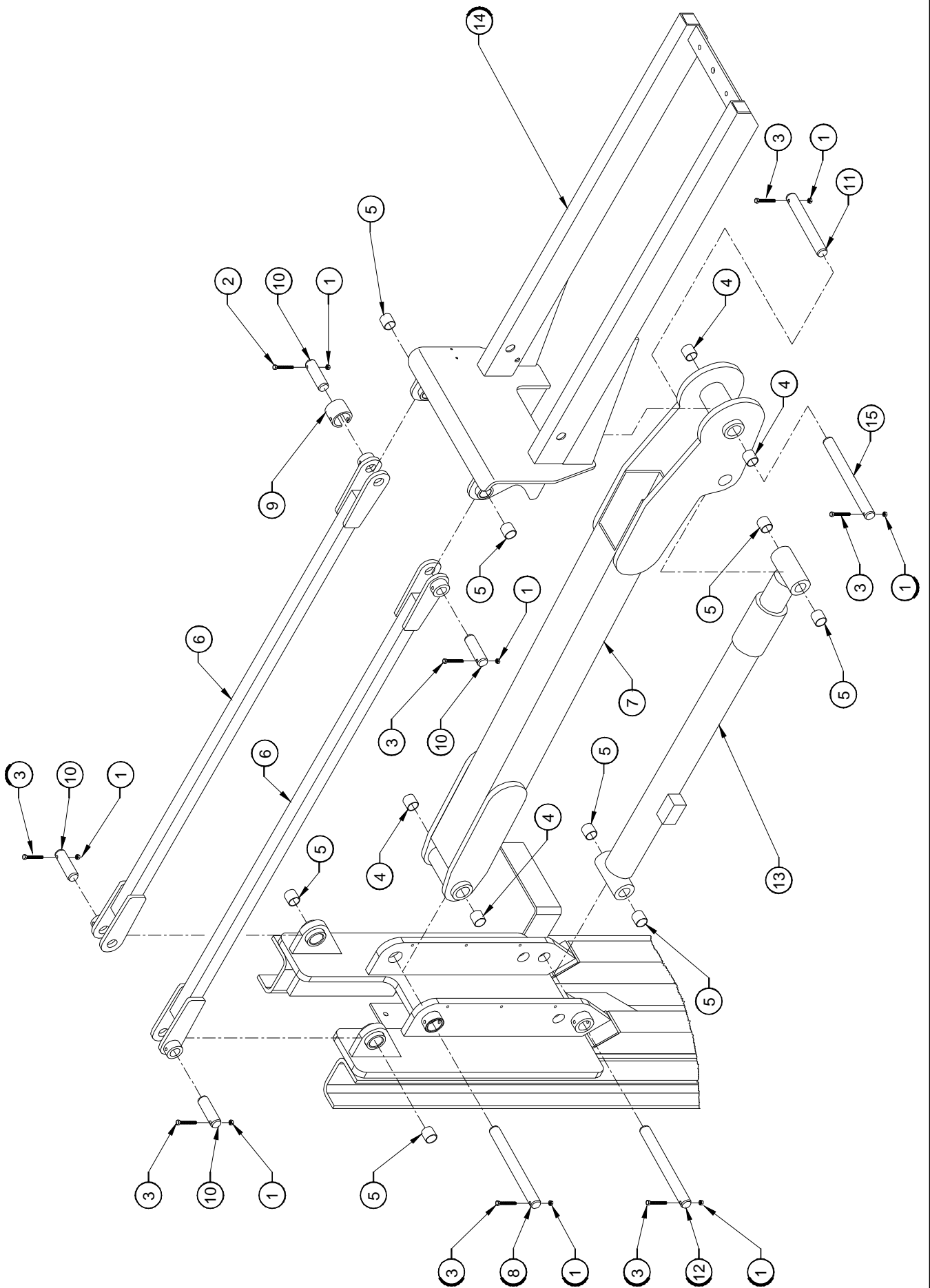

DATE : 11/12/97

JIB INSTALL

MONTAGE N°/

ASSY NO : SP0219 REV :

INSTALLATION BRAS

1/1

DET NO.	REF./PART NUMBER	VOIR/ SEE VIEW	DESCRIPTION		R E V	Qté/ Qty Req.
1	110003		M06 GR. 8.8 LOCK NUT	ECROU FREIN M6 8.8 BI		8
2	100020		M06x60 8.8 HEX HEAD CAPSCREW	VIS H M06x60 8.8 BI FP		1
3	100137		M06x50 8.8 HEX HEAD MACHINE SCREW	VIS H M06x50 8.8 BI FT		7
4	150001		BUSHING Ø30 H30 DX	BAGUE Ø30 H30 DX		4
5	150002		BUSHING Ø25 H25 DX	BAGUE Ø25 H25 DX		8
6	DL0388		CONTROL ARM	TIRANT		2
7	DL0390		UPPER JIB	BRAS		1
8	US0007		JIB ARM PIN	AXE DE BRAS		1
9	US0094		HIGH SPEED DRIVE CUTOUT CAM	CAME CAPTEUR		1
10	US0145		PULLEY PIN	AXE DE SUPPORT POULIE		4
11	US0210		CYLINDER PIN/JIB ARM	AXE VERIN/BRAS		1
12	US0212		CYLINDER PIN/MAST	AXE VERIN/MAT		1
13		APPENDIX A	JIB CYLINDER	VERIN DE BRAS		1
14		APPENDIX H	PLATFORM INSTALL	INSTALLATION PANIER		1
15	US0209		JIB ARM PIN	AXE DE BRAS		1

SPARE PARTS PIECES DETACHEES

APPENDIX-ANNEXES

- A-** CYLINDERS
VERINS
- B-** CHAIN SLACK SWITCHES INSTALL
INSTALLATION CAPTEURS DE CHAINE
- C-** UPPER CONTROL VALVE INSTALL
INSTALLATION DISTRIBUTEUR HAUT
- D-** TIRE AND WHEEL INSTALL
INSTALLATION DES ROUES
- E-** HYDRAULIC MOTORS INSTALL
INSTALLATION DES MOTEURS
- F-** BATTERY AND CHARGER INSTALL
INSTALLATION BATTERIE ET CHARGEUR
- G-** DECALS INSTALL
INSTALLATION DES AUTOCOLLANTS
- H-** PLATFORM INSTALL
INSTALLATION DU PANIER



SPARE PARTS
PIECES DETACHEES

SECTION A.

CYLINDERS.
VERINS.

DATE : 19/06/02

MAST CYLINDER

MONTAGE N°/
ASSY NO : RM0084 REV :

VERIN DE MAT

1/1

To order check mark on marking zone and indicate machine serial number.
Pour commander vérifier la marque sur la zone de marquage et indiquer le numéro de série de la machine.

MARK MARQUE	DET. NO. 1	CYLINDERS PART NUMBER REFERENCE VERINS	DET. NO. 2	SEAL KIT ITEM REFERENCE KIT DE JOINT	REV
V 99/32 (Year/Week - An/Sem)		ST0323		900123	
EUROMAT 15/99 ST1394		ST1394		900085	
SAHL 15/99 ST1754		ST1754		960072	

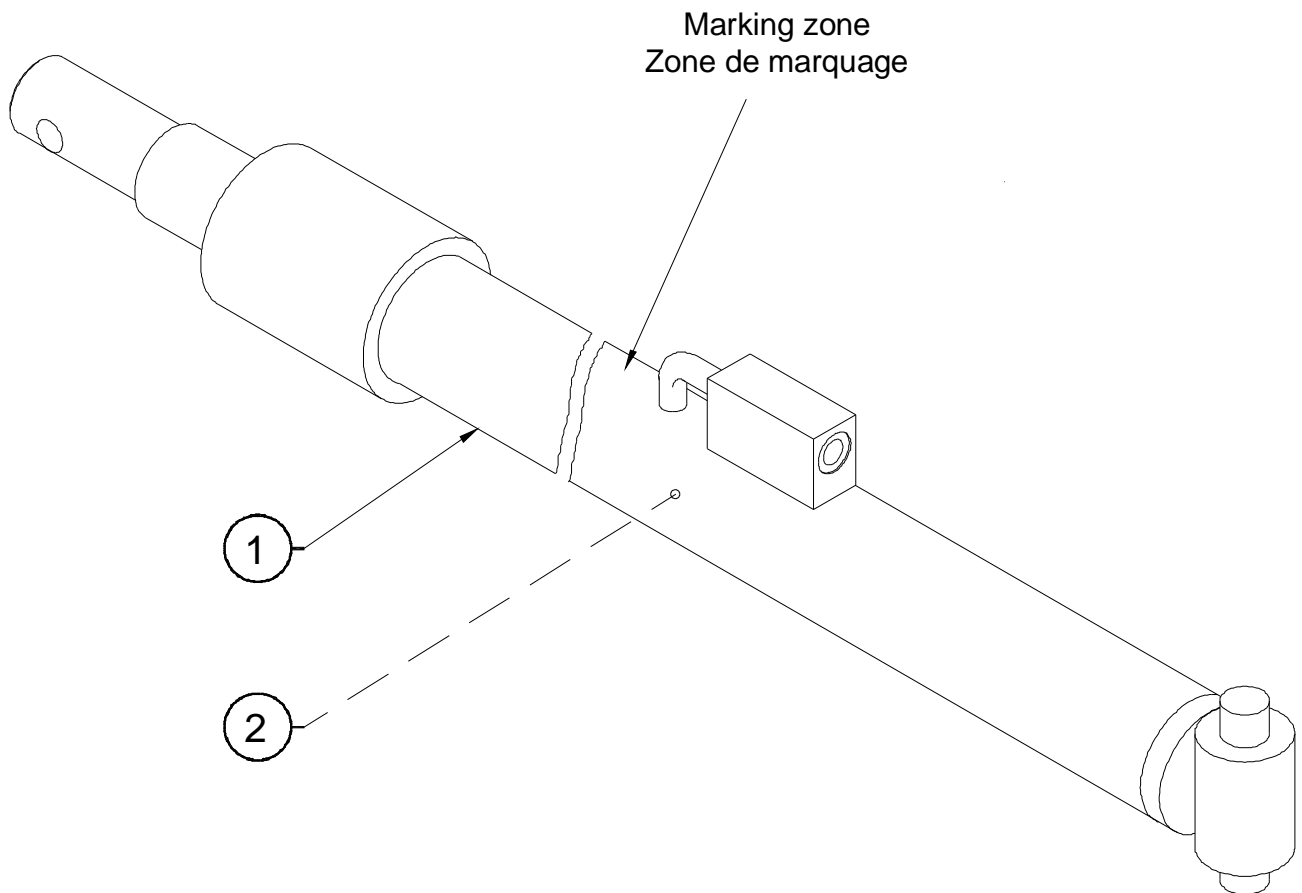

DATE : 19/06/02

JIB CYLINDER

MONTAGE N°/
ASSY NO : RM0085 REV :

VERIN DE BRAS

1/1

To order check mark on marking zone and indicate machine serial number.

Pour commander vérifier la marque sur la zone de marquage et indiquer le numéro de série de la machine.

MARK MARQUE	DET. NO. 1	CYLINDERS PART NUMBER REFERENCE VERINS	DET. NO. 2	SEAL KIT ITEM REFERENCE KIT DE JOINT	REV
V 99/32 (Year/Week - An/Sem)		ST0324		900123	
EUROMAT 15/99 ST1393		ST1393		900085	
SAHL 15/99 ST1753		ST1753		960072	

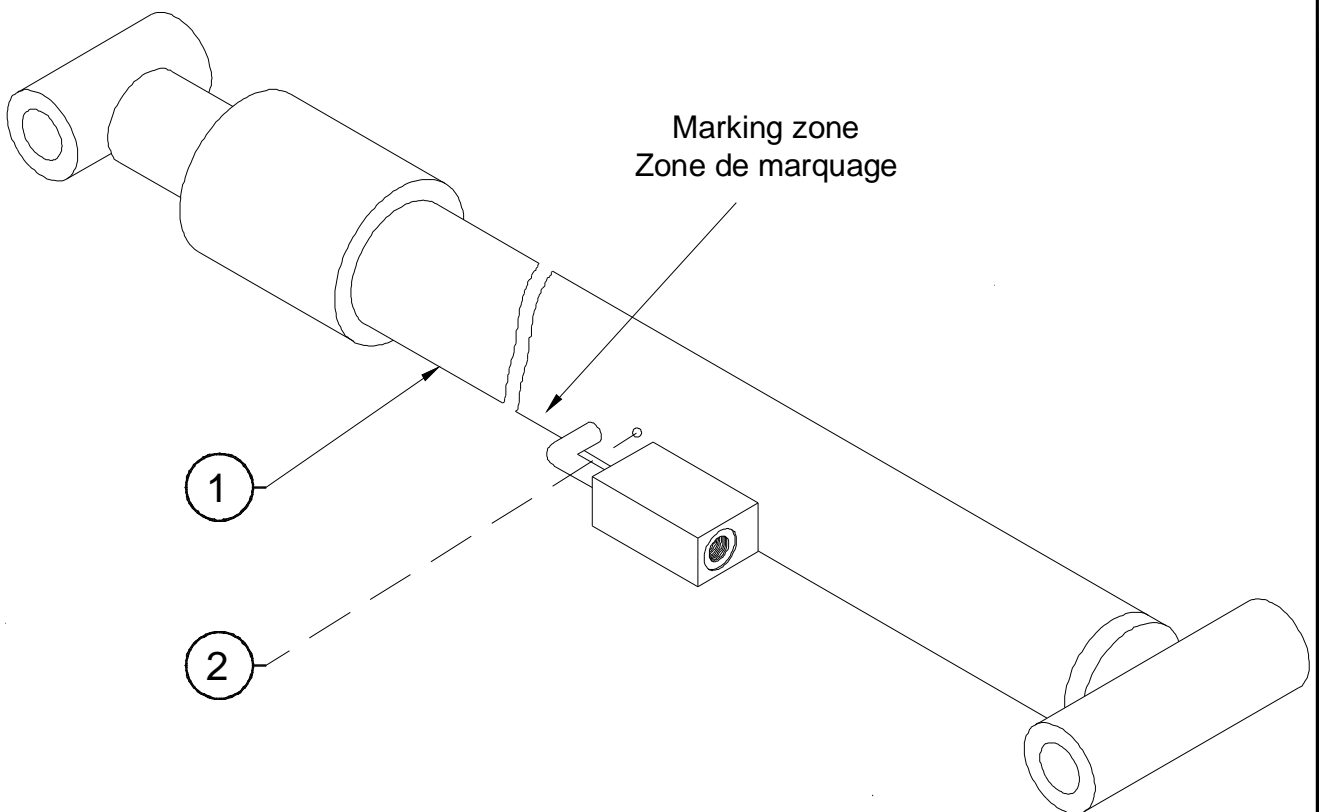

DATE : 03/02/98

STEER CYLINDER

MONTAGE N°/
ASSY NO : ST0177 REV :

VERIN DE DIRECTION

1/1

DET NO.	REF./PART NUMBER	VOIR/ SEE VIEW	DESCRIPTION		REV	Qté/ Qty Req.
1	ST0177		STEER CYLINDER	VERIN DE DIRECTION		1
2	900124		SEAL KIT	KIT DE JOINTS		1

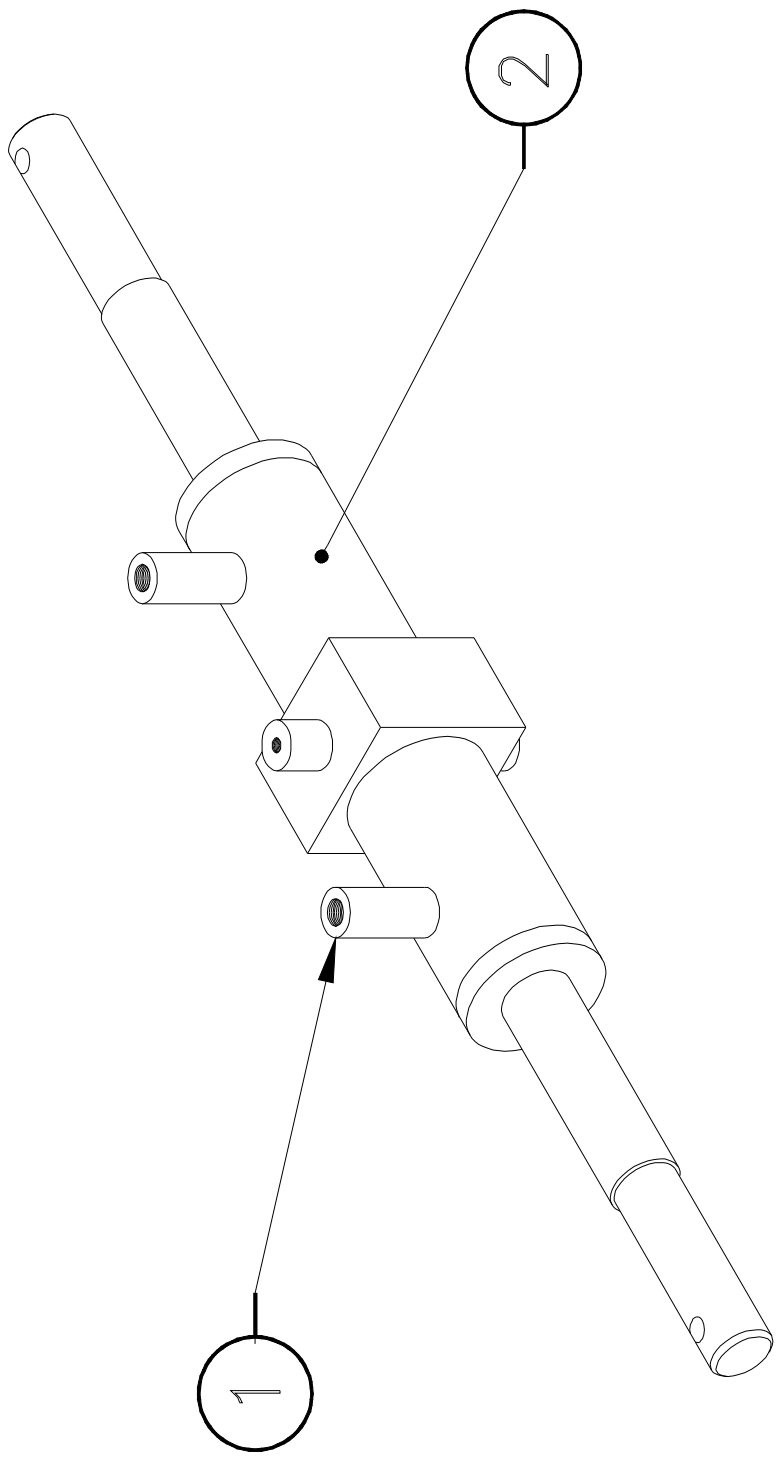

A

ST0177

A

DATE : 22/01/98

BRAKE CYLINDER

MONTAGE N°/

ASSY NO : SD0048 REV :

VERIN FREIN

1/1

DET NO.	REF./PART NUMBER	VOIR/ SEE VIEW	DESCRIPTION		R E V	Qté/ Qty Req.
1	160005		BRAKE CYLINDER SPRING	RESSORT VERIN FREIN		1
2	900010		BRAKE CYLINDER SEAL KIT	KIT DE JOINTS VERIN FREIN		1
3	930057		CYLINDER BARREL	CORPS VERIN FREIN		1
4	930058		CYLINDER ROD	TIGE DE VERIN		1
5	930070		CYLINDER PISTON	PISTON		1
6	930071		CYLINDER HEAD	TETE DE VERIN		1
7	SD0048		BRAKE CYLINDER	VERIN FREIN		2

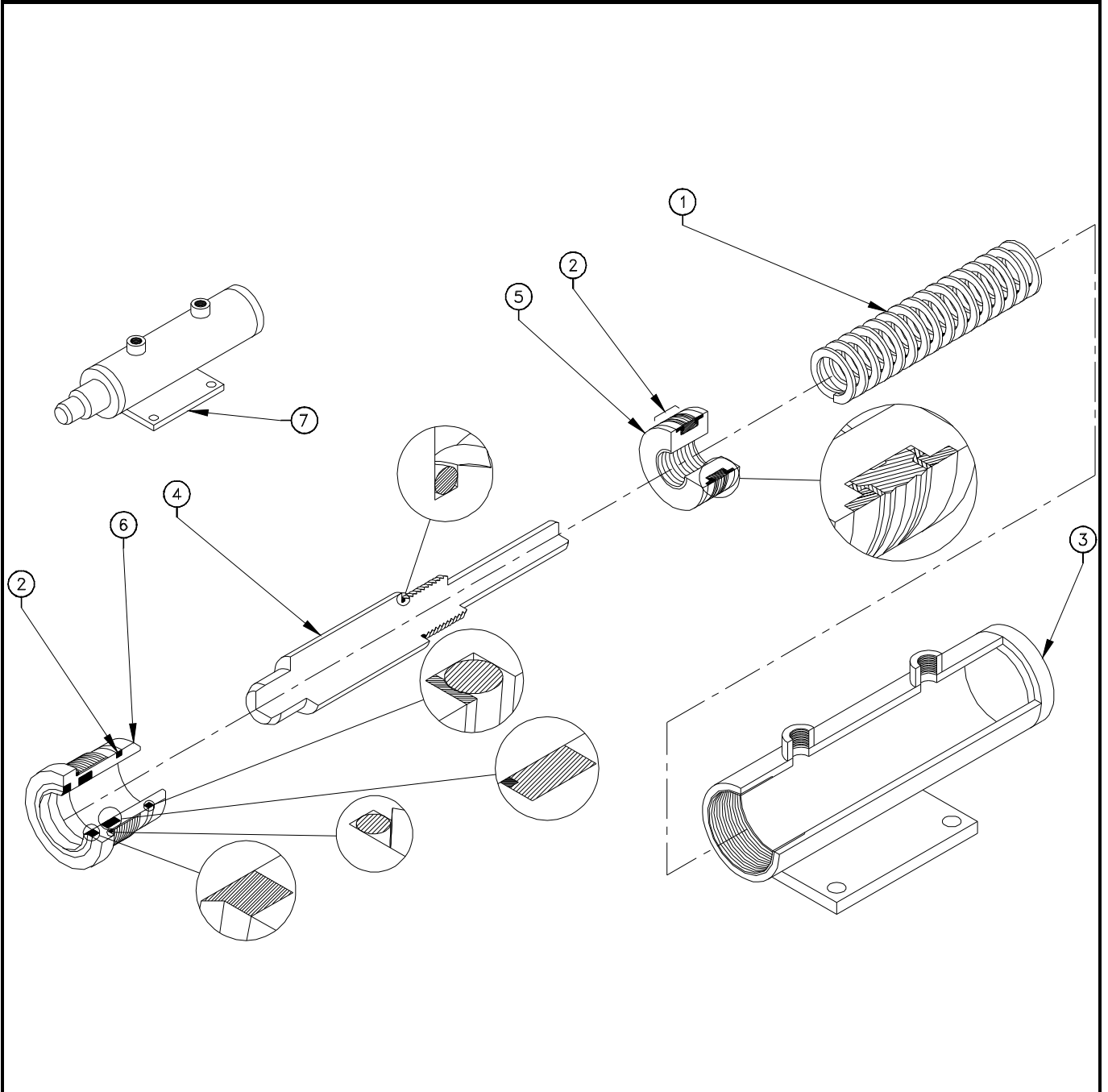

A

SD0048

A

SPARE PARTS
PIECES DETACHEES

SECTION B.

DOUBLE SWITCHES BY CHAIN STAGE.
2 CAPTEURS PAR ETAGE DE CHAINE.

DOUBLE SWITCHES BY CHAIN STAGE

2 CAPTEURS PAR ETAGE DE CHAINE

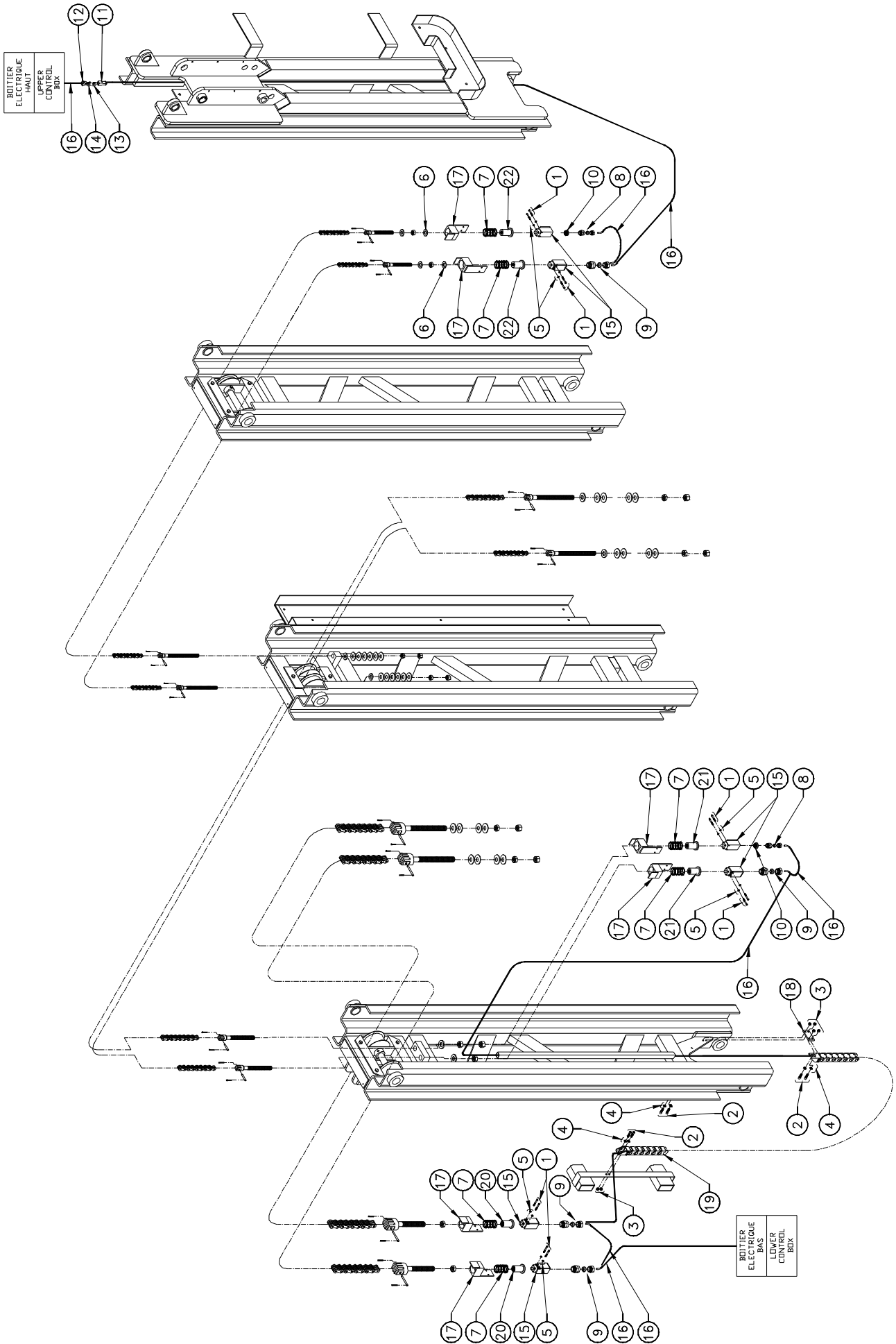

DATE : 18/02/98

DOUBLE SWITCHES BY CHAIN STAGE

MONTAGE N°/

ASSY NO : SP0243 REV :

2 CAPTEURS PAR ETAGE DE CHAINE

1/1

DET NO.	REF./PART NUMBER	VOIR/ SEE VIEW	DESCRIPTION		RE V	Qté/ Qty Req.
1	000007		M04x30 8.8 SOCKET HEAD CAPSCREW	VIS CHC M04x30 8.8 BI FP		12
2	000005		M06x20 8.8 SOCKET HEAD MACH SCREW	VIS CHC M06x20 8.8 BI FT		6
3	110003		M06 GR. 8.8 LOCK NUT	ECROU FREIN M6 8.8 BI		6
4	120009		dD 06x14 LOCK WASHER	RONDELLE CONTACT dD 06x14 BI		6
5	120024		M04 LOCK WASHER	RONDELLE CONTACT M04 BI		12
6	120025		Ddh 28x14x2.5 WASHER	RONDELLE Ddh 28x14x2.5 BI		2
7	160010		C 360 450 320 SPRING	RESSORT C 360 450 320		6
8	210017		GLAND N°9	PRESSE ETOUPE N°9		2
9	210019		GLAND N°13	PRESSE ETOUPE N°13		4
10	250015		REDUCTION 13/9	REDUCTION 13/9		2
11	250032		2 POSITIONS CAP HOUSING	CONNECTEUR FEMELLE 2 BROCHES		1
12	250033		2 POSITIONS PLUG HOUSING	CONNECTEUR MALE 2 BROCHES		1
13	250034		BLADE TERMINAL 6.3mm	COSSE PLATE MALE 6.3mm		2
14	250035		RECEPTACLE TERMINAL 6.3mm	COSSE PLATE FEMELLE 6.3mm		2
15	260016		SWITCH	CAPTEUR		6
16	270010		CABLE 2x1mm² (quantity indicated in meter)	CABLE 2x1mm² (qté indiquée en mètre)		18
17	SD0464		SWITCH HOLDER	SUPPORT CAPTEUR		6
18	ST0840		POWER BRIDGE SUPPORT	SUPPORT CHAINE		1
19	ST1389		POWER BRIDGE	CHAINE PORTE CABLES		1
20	US0203		ACTUATOR M20	ACTIONNEUR M20		2
21	US0204		ACTUATOR M16	ACTIONNEUR M16		2
22	US0208		ACTUATOR M14	ACTIONNEUR M14		2

B

SP0243

B

SPARE PARTS
PIECES DETACHEES

SECTION B.

SINGLE SWITCH BY CHAIN STAGE.
1 CAPTEUR PAR ETAGE DE CHAINE.

SINGLE SWITCH BY CHAIN STAGE 1 CAPTEUR PAR ETAGE DE CHAINE

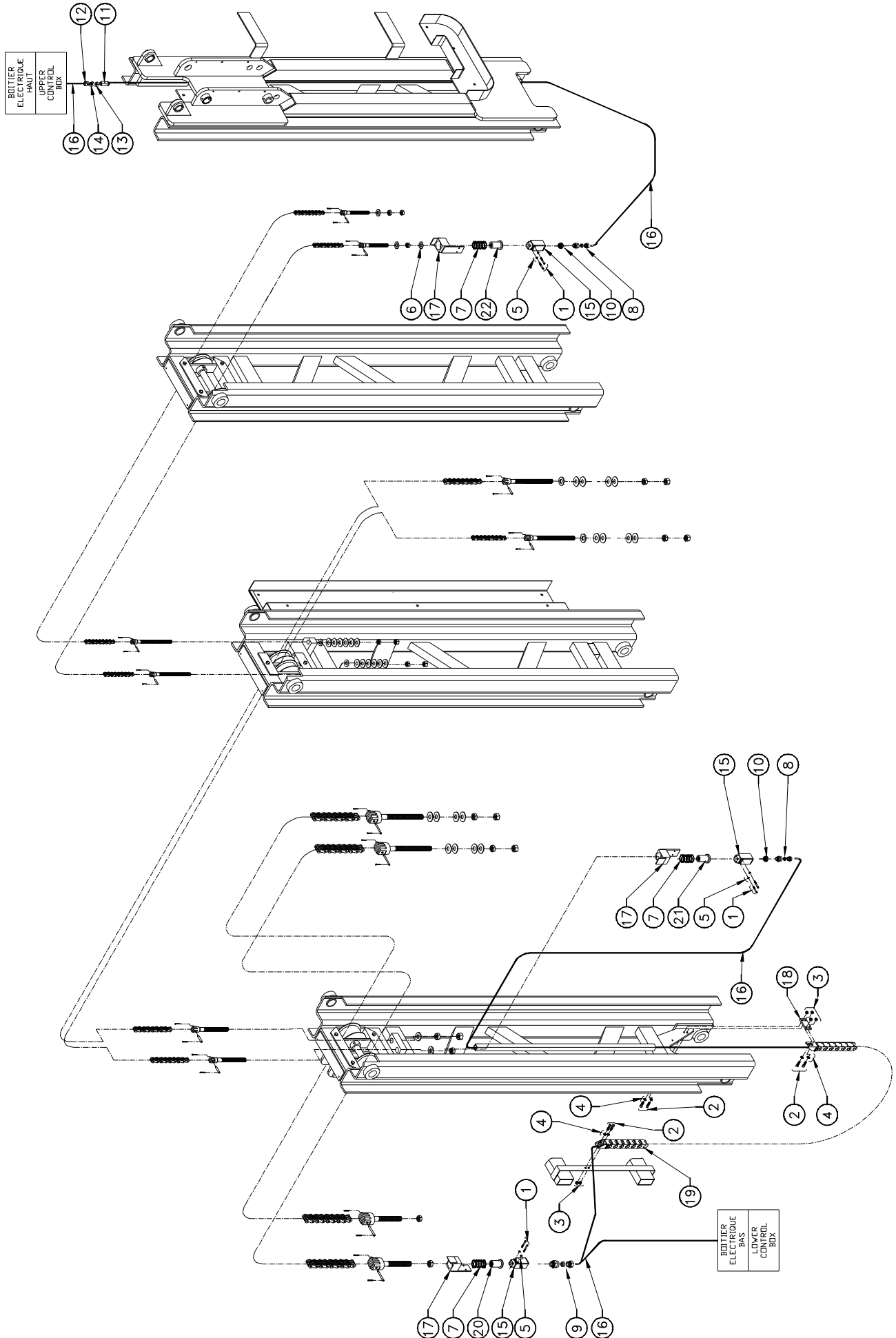

DATE : 08/01/98

SINGLE SWITCH BY CHAIN STAGE

MONTAGE N°/

ASSY NO : SP0233 REV :

1 CAPTEUR PAR ETAGE DE CHAINE

1/1

DET NO.	REF./PART NUMBER	VOIR/ SEE VIEW	DESCRIPTION		RE V	Qté/ Qty Req.
1	000007		M04x30 8.8 SOCKET HEAD CAPSCREW	VIS CHC M04x30 8.8 BI FP		6
2	000005		M06x20 8.8 SOCKET HEAD MACH SCREW	VIS CHC M06x20 8.8 BI FT		6
3	110003		M06 GR. 8.8 LOCK NUT	ECROU FREIN M6 8.8 BI		6
4	120009		dD 06x14 LOCK WASHER	RONDELLE CONTACT dD 06x14 BI		6
5	120024		M04 LOCK WASHER	RONDELLE CONTACT M04 BI		6
6	120025		Ddh 28x14x2.5 WASHER	RONDELLE Ddh 28x14x2.5 BI		1
7	160010		C 360 450 320 SPRING	RESSORT C 360 450 320		3
8	210017		GLAND N°9	PRESSE ETOUPE N°9		2
9	210019		GLAND N°13	PRESSE ETOUPE N°13		1
10	250015		REDUCTION 13/9	REDUCTION 13/9		2
11	250032		2 POSITIONS CAP HOUSING	CONNECTEUR FEMELLE 2 BROCHES		1
12	250033		2 POSITIONS PLUG HOUSING	CONNECTEUR MALE 2 BROCHES		1
13	250034		BLADE TERMINAL 6.3mm	COSSE PLATE MALE 6.3mm		2
14	250035		RECEPTACLE TERMINAL 6.3mm	COSSE PLATE FEMELLE 6.3mm		2
15	260016		SWITCH	CAPTEUR		3
16	270010		CABLE 2x1mm ² (quantity indicated in meter)	CABLE 2x1mm ² (qté indiquée en mètre)		15.5
17	SD0464		SWITCH HOLDER	SUPPORT CAPTEUR		3
18	ST0840		POWER BRIDGE SUPPORT	SUPPORT CHAINE		1
19	ST1389		POWER BRIDGE	CHAINE PORTE CABLES		1
20	US0203		ACTUATOR M20	ACTIONNEUR M20		1
21	US0204		ACTUATOR M16	ACTIONNEUR M16		1
22	US0208		ACTUATOR M14	ACTIONNEUR M14		1

SPARE PARTS
PIECES DETACHEES

SECTION C.

AUSTRALIA UPPER VALVE ASSEMBLY.
ASSEMBLAGE DISTRIBUTEUR HAUT AUSTRALIE.

AUSTRALIA UPPER VALVE ASSEMBLY ASSEMBLAGE DISTRIBUTEUR HAUT AUSTRALIE

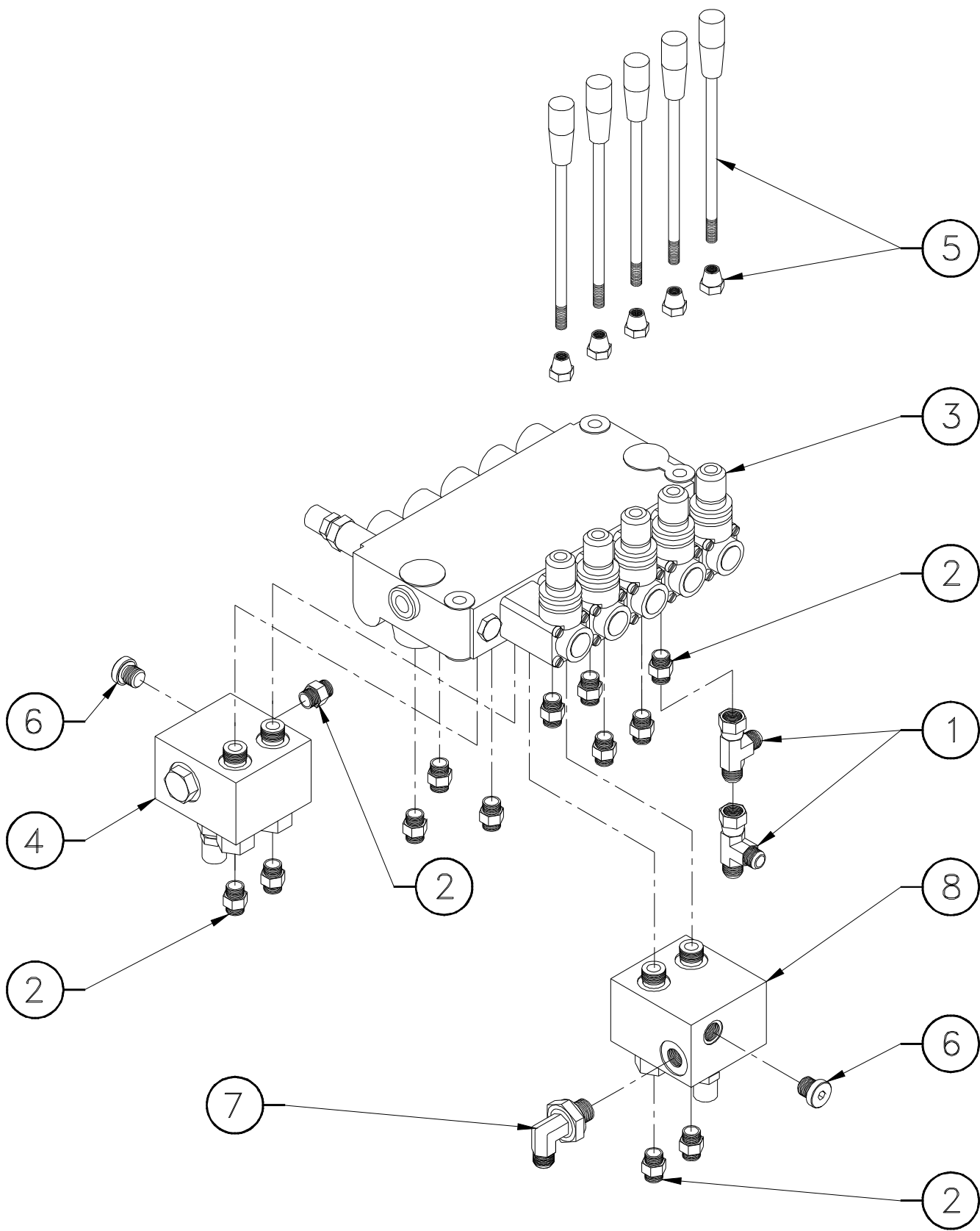

PILOT BLOCK BLOC PILOTAGE

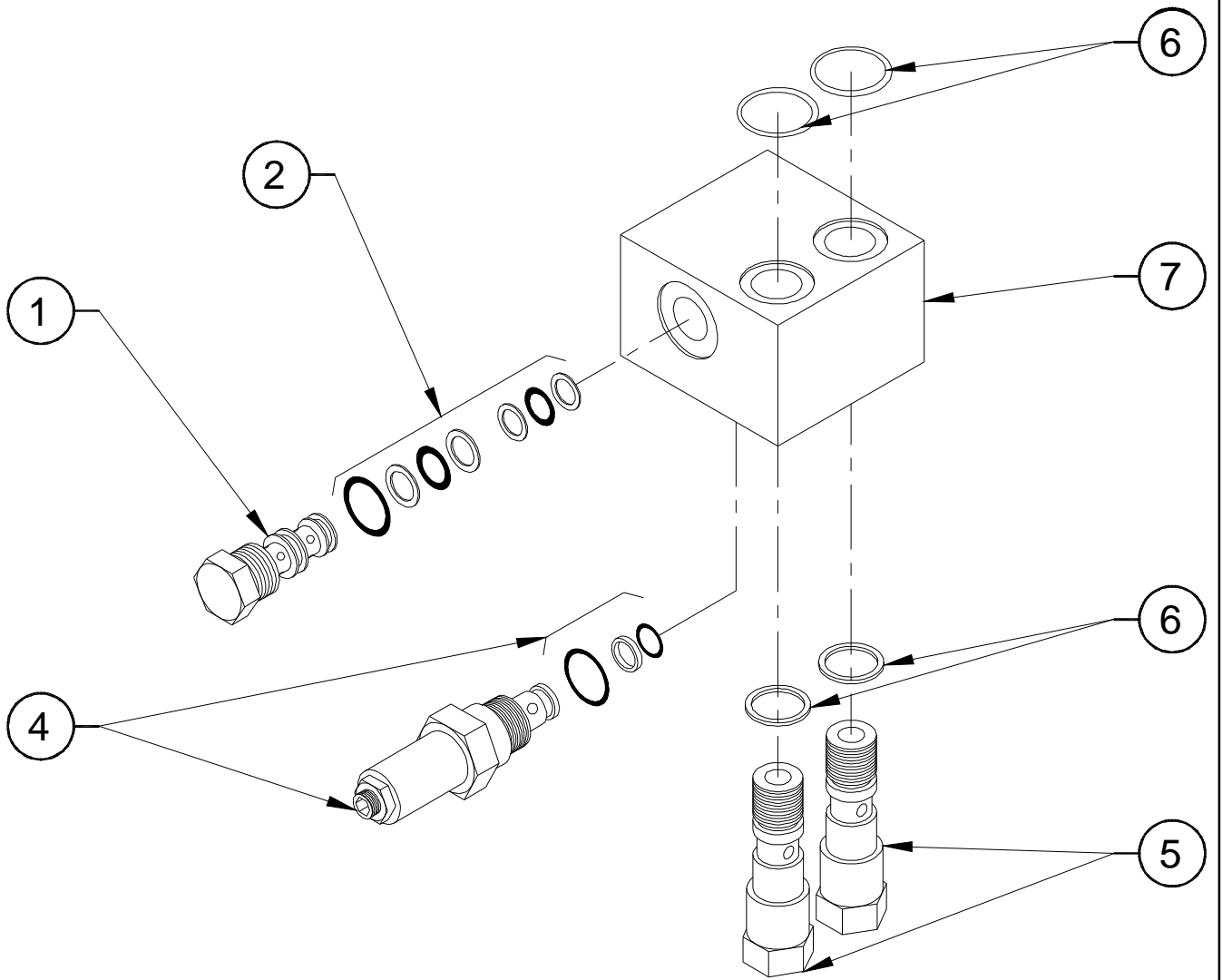

PILOT BLOCK BLOC PILOTAGE

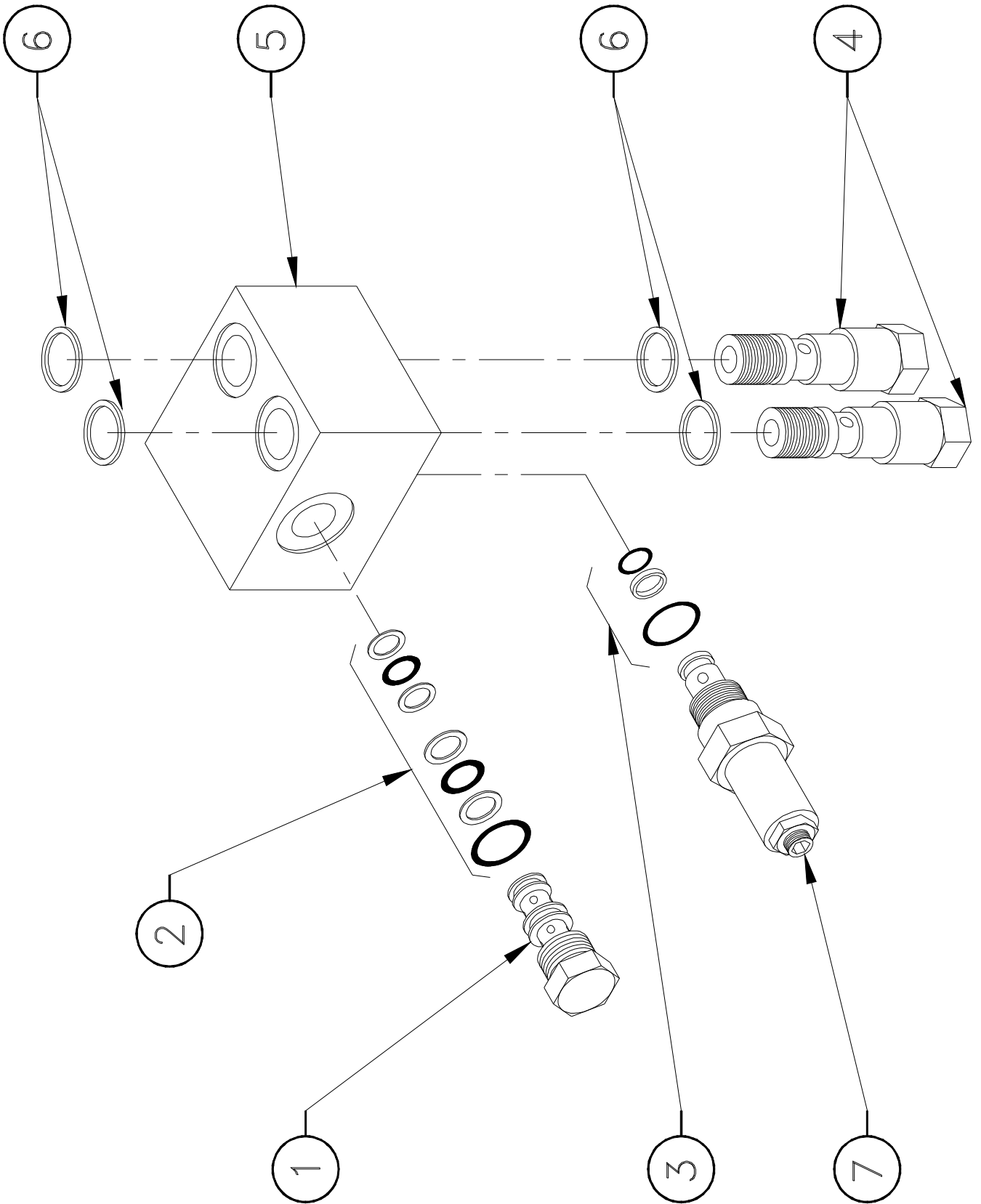

SPARE PARTS
PIECES DETACHEES

SECTION C.

UPPER VALVE ASSEMBLY FOR CE.
ASSEMBLAGE DISTRIBUTEUR HAUT CE.

UPPER VALVE ASSEMBLY FOR CE ASSEMBLAGE DISTRIBUTEUR HAUT CE

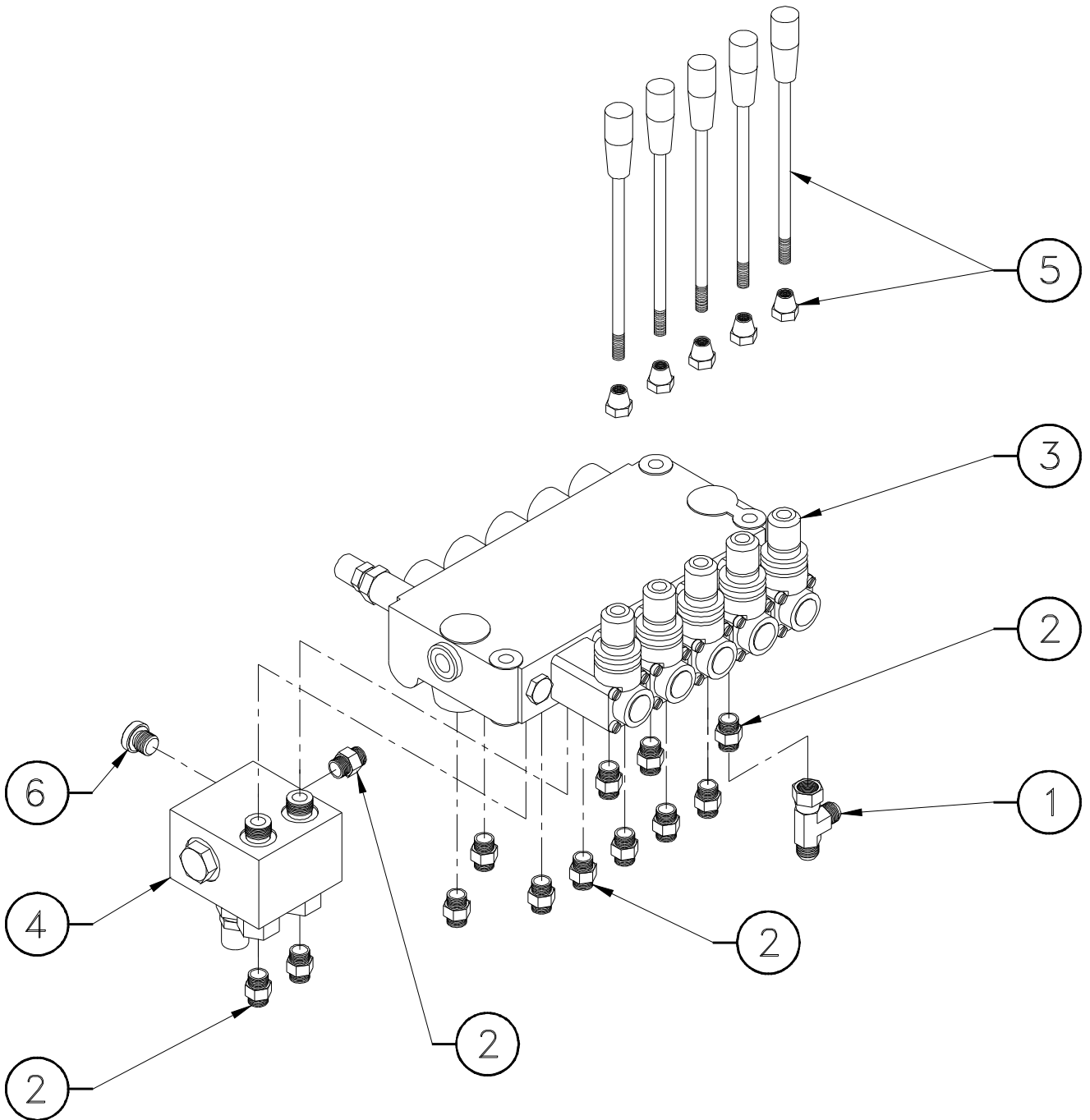

PILOT BLOCK BLOC PILOTAGE

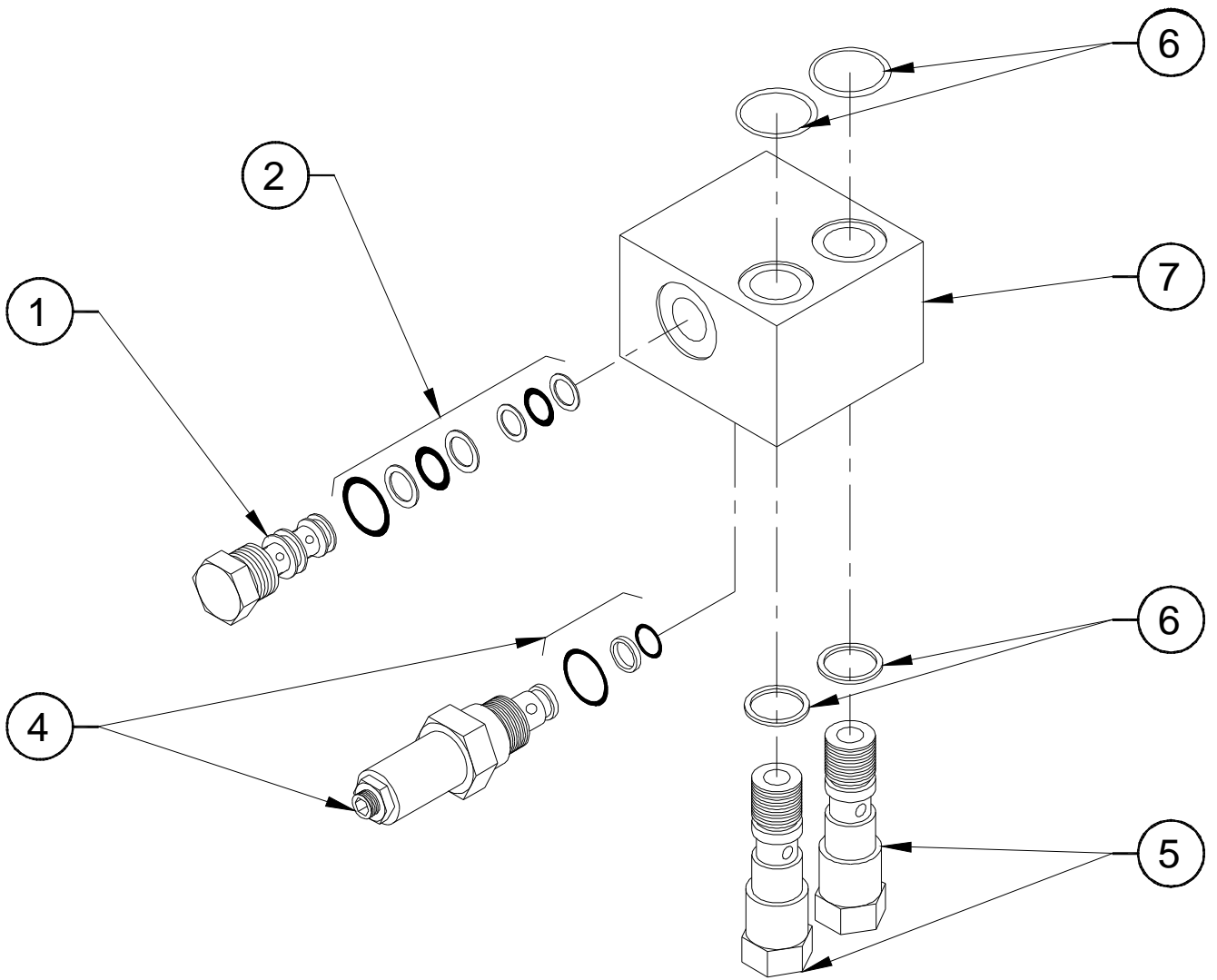

DATE : 24/01/05

PILOT BLOCK

MONTAGE N°/
 ASSY NO : 520035 REV : A

BLOC PILOTAGE

DET NO.	REF./PART NUMBER	VOIR/ SEE VIEW	DESCRIPTION		R	E	Qté/ Qty
							Req.
1	900068		SHUTTLE VALVE	SELECTEUR DE CIRCUIT			1
2	900072		SEAL KIT	KIT DE JOINTS			1
3			NOT REQUIRED	NON REQUIS	A		1
4	952075		PRESSURE RELIEF VALVE	LIMITEUR DE PRESSION	A		1
5	920013		BANJO VALVE	CLAPET BANJO			2
6	920014		SEAL KIT	KIT DE JOINTS			2
7	920015		MANIFOLD	BLOC FORE			1

SPARE PARTS
PIECES DETACHEES

SECTION D.

TIRE AND WHEEL INSTALL.
INSTALLATION DES ROUES.

DATE : 22/01/98

TYRE & WHEEL STANDARD

MONTAGE N°/

ASSY NO : SP0201 REV :

ROUES STANDARD

1/1

DET NO.	REF./PART NUMBER	VOIR/ SEE VIEW	DESCRIPTION		REV	Qté/ Qty Req.
1	DL0270		DRIVE & BRAKE WHEELS	ROUES MOYEU FREIN		2
2	ST0650		STEERING WHEELS	ROUES DIRECTRICES		2

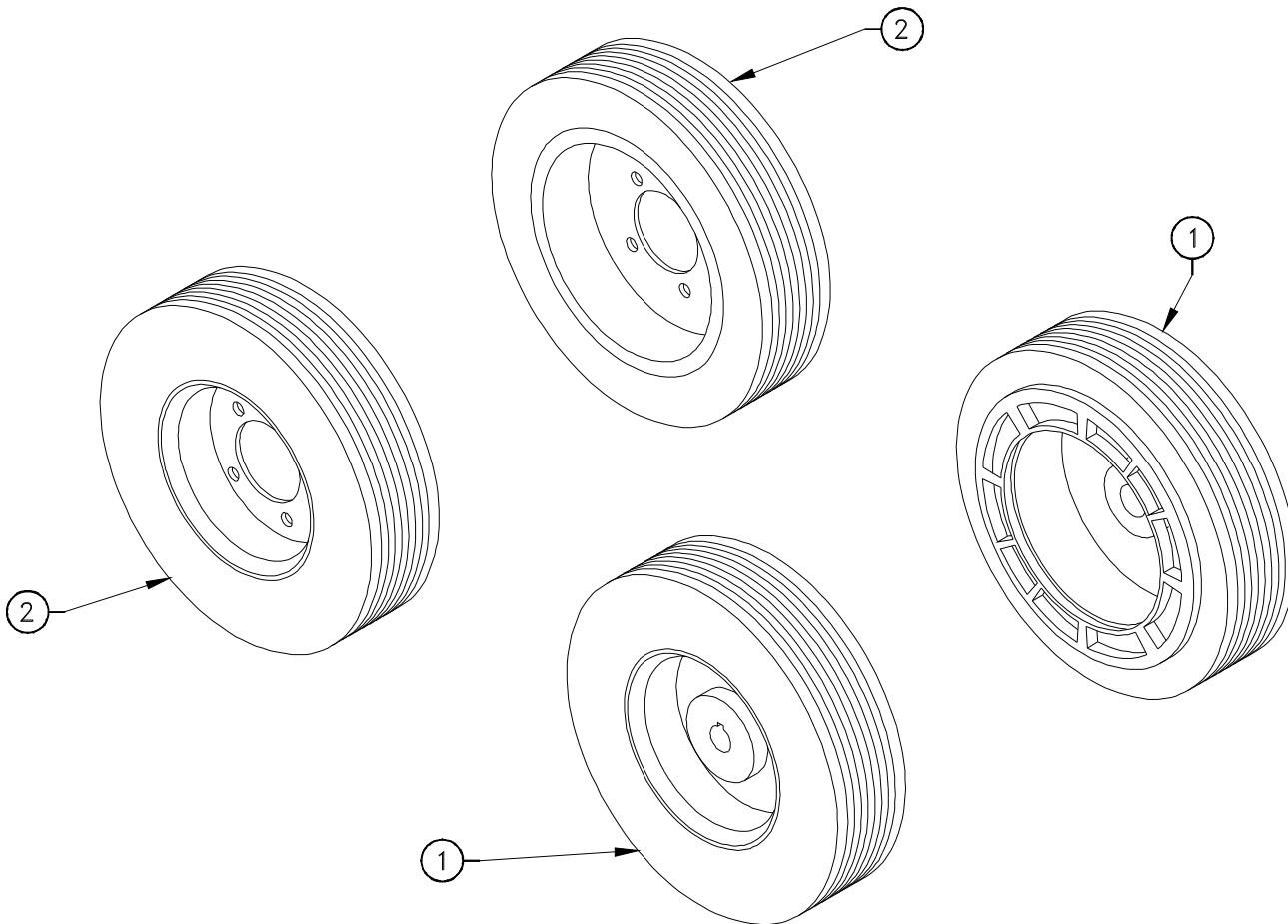

DATE : 22/01/98

TYRE & WHEEL NON MARKING

MONTAGE N°/

ASSY NO : SP0200 REV :

ROUES NON MARQUANTES

1/1

DET NO.	REF./PART NUMBER	VOIR/ SEE VIEW	DESCRIPTION		REV	Qté/ Qty Req.
1	DL0277		DRIVE & BRAKE WHEELS	ROUES MOYEU FREIN		2
2	ST0701		STEERING WHEELS	ROUES DIRECTRICES		2
3	130022		STATIC STRAP	TRESSE DE MASSE		1

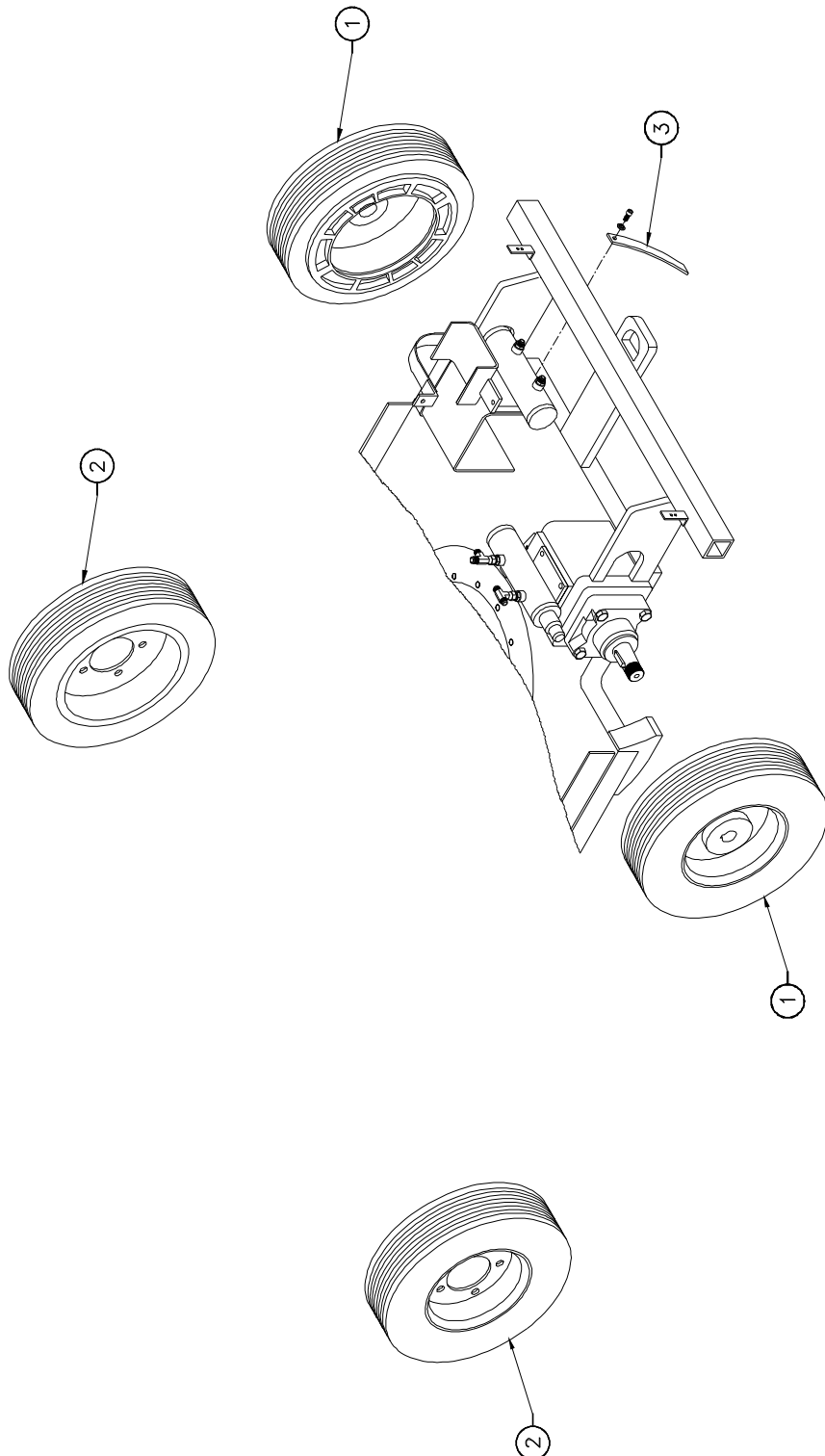

SPARE PARTS
PIECES DETACHEES

SECTION E.

**SWING MOTOR AND HYDRAULIC MOTORS
INSTALL.**

**INSTALLATION DU MOTEUR D'ORIENTATION
ET DES MOTEURS DE ROUES.**

SWING MOTOR 32cc/rev
MOTEUR D'ORIENTATION 32cm³/t

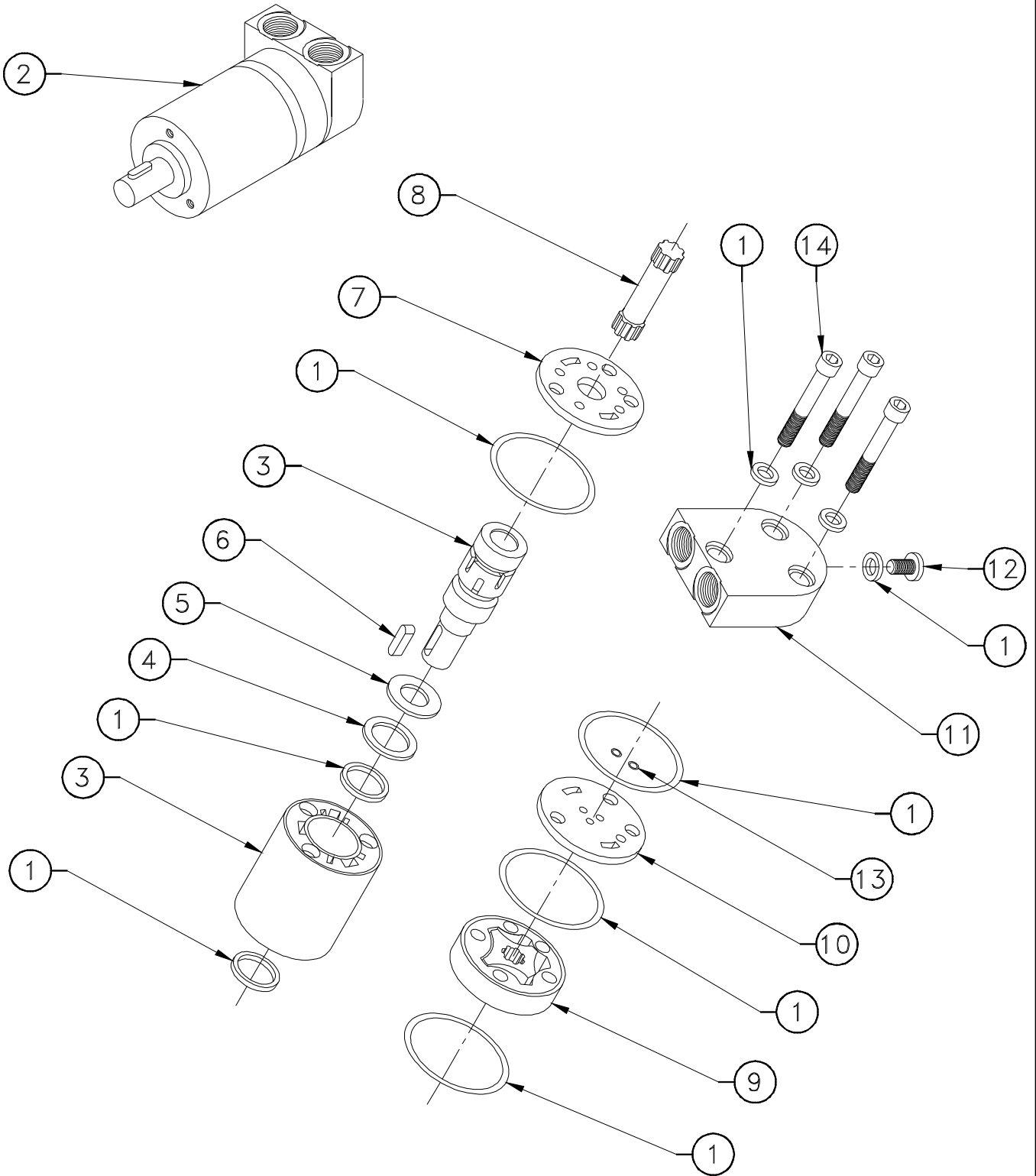

DATE : 22/01/98

SWING MOTOR 32cc/rev

MONTAGE N°/

ASSY NO : 320006 REV :

MOTEUR D'ORIENTATION 32cm³/t

1/1

DET NO.	REF./PART NUMBER	VOIR/ SEE VIEW	DESCRIPTION		R E V	Qté/ Qty Req.
1	900043		SEAL KIT	KIT DE JOINTS		1
2	320006		SWING MOTOR 32cc/rev	MOTEUR D'ORIENTATION 32cm³/t		1
3			HOUSING + OUTPUT SHAFT	CORPS DE MOTEUR		1
4			BEARING RACE	CHEMIN DE ROULEMENT		1
5			AXIAL NEEDLE BEARING	BUTEE A AIGUILLE		1
6	950006		KEY SWING MOTOR	CLAVETTE MOTEUR		1
7			DISTRIBUTOR PLATE	GLACE DE DISTRIBUTION		1
8			CARDAN SHAFT	AXE CARDAN		1
9			GEARWHEEL SET	ENGRENAGES		1
10			INTERMEDIAIRE PLATE	GLACE INTERMEDIAIRE		1
11			END COVER	COUVERCLE		1
12			DRAIN PLUG	BOUCHON		1
13			CHECK VALVE BALL	JOINTS		1
14			M08-55 8.8 SOCK. HEAD CAPSCREW	VIS CHC M08-55 8.8		1

HYDRAULIC MOTOR MB240

MOTEUR HYDRAULIQUE MB240

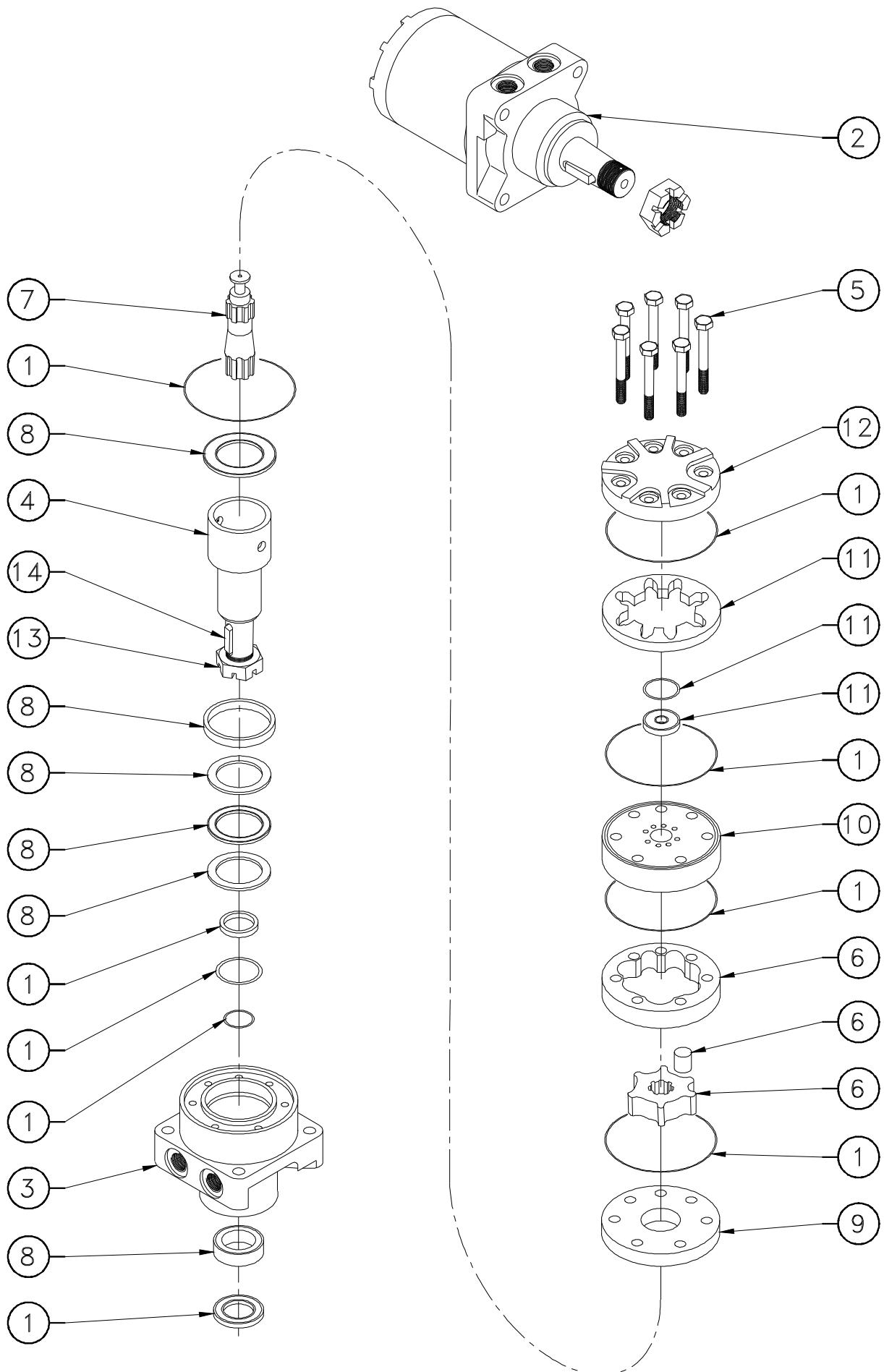

HYDRAULIC MOTOR ME330

MOTEUR HYDRAULIQUE ME330

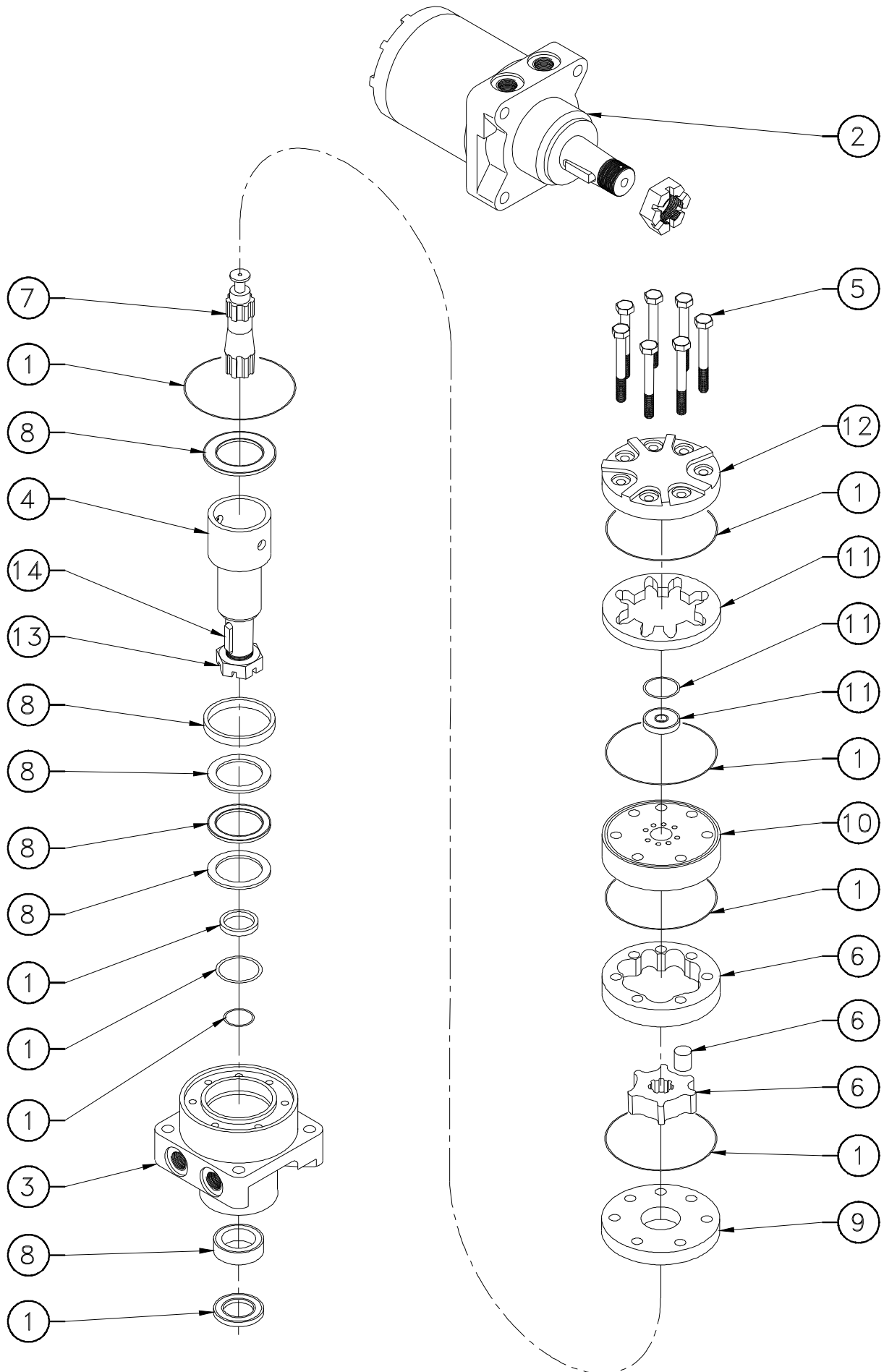

DATE : 17/04/98

HYDRAULIC MOTOR ME330

MONTAGE N°/

ASSY NO : 320025 REV :

MOTEUR HYDRAULIQUE ME330

1/1

DET NO.	REF./PART NUMBER	VOIR/ SEE VIEW	DESCRIPTION		RE V	Qté/ Qty Req.
1	900022		SEAL KIT	KIT DE JOINTS		1
2	320025		HYDRAULIC MOTOR ME330	MOTEUR HYDRAULIQUE ME330		1
3			HOUSING	FLASQUE MOTEUR		1
4			COUPLING SHAFT	ARBRE DE ROUE		1
5			SPECIAL SCREW	VIS		1
6			ROTOR SET	KIT ROTOR		1
7			DRIVE LINK	ARBRE DE LIAISON		1
8			BEARING KIT	JEU DE BAGUES		1
9			WEAR PLATE	PLAQUE DE DISTRIBUTION		1
10			MANIFOLD	BLOC DE DISTRIBUTION		1
11			COMMUTATOR ASSEMBLY	SYSTEME DE DISTRIBUTION		1
12			END COVER	COUVERCLE		1
13	920040		CASTLE NUT	ECROU		1
14	920039		KEY	CLAVETTE		1

SPARE PARTS
MANUEL DE PIECES DETACHEES

SECTION F.

**CHARGER AND BATTERY INSTALL.
INSTALLATION CHARGEUR ET BATTERIE.**

FULMEN CHARGER 110/220V 65A CHARGEUR 110/220V 65A FULMEN

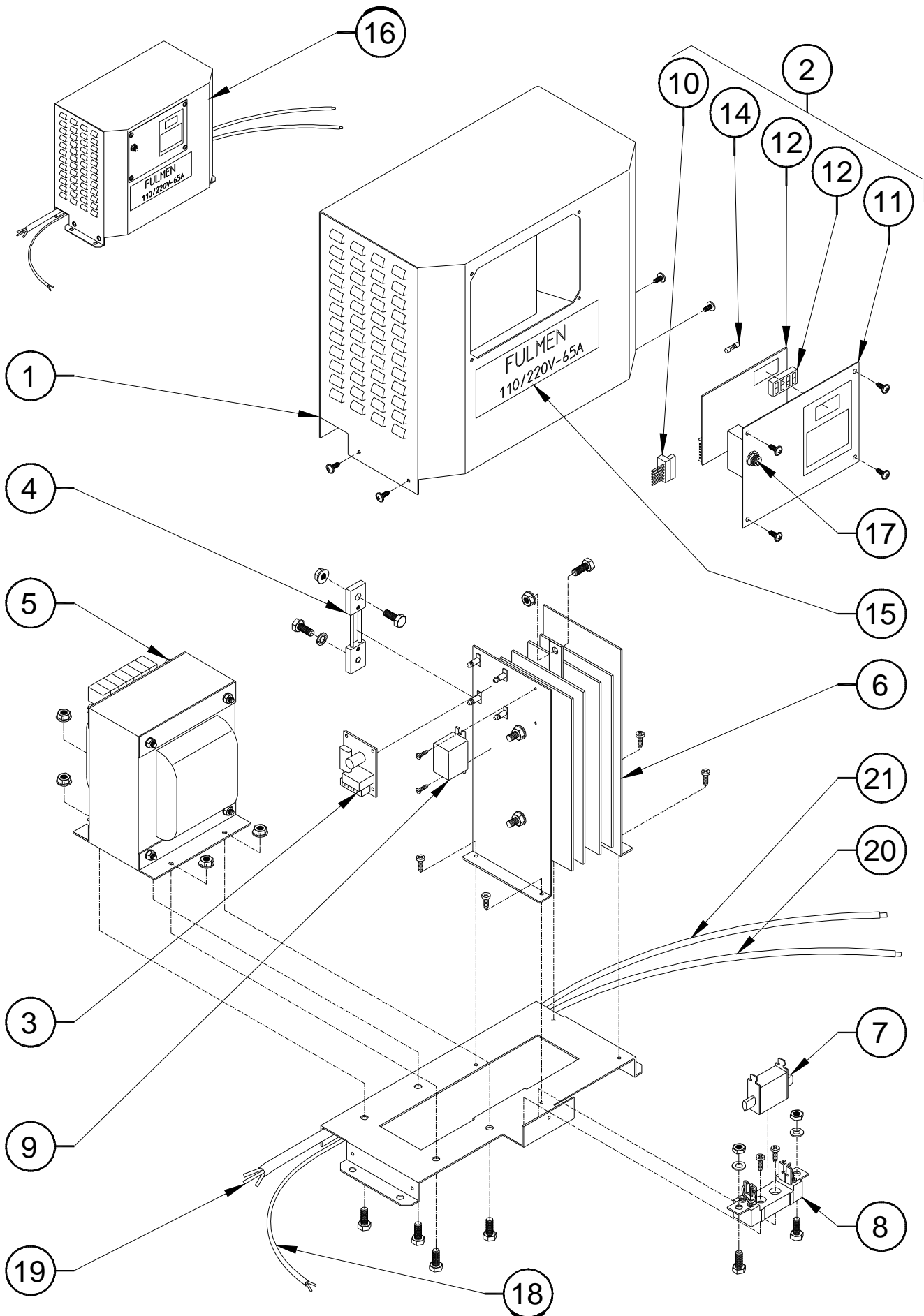

DATE : 18/10/97

FULMEN CHARGER 110/220V 65A

MONTAGE N°/

ASSY NO : 510010 REV : B

CHARGEUR 110/220V 65A FULMEN

1/1

DET NO.	REF./PART NUMBER	VOIR/ SEE VIEW	DESCRIPTION		RE V	Qté/ Qty Req.
1	950016		CHARGER COVER	CAPOT CHARGEUR		1
2	950017		CONTROL PANEL	PANNEAU DE CONTROLE		1
3	950162		"F30" SECURITY CARD	CARTE DE SECURITE "F30"	B	1
4	950019		THERMAL PROTECTOR	PROTECTION THERMIQUE		1
5	950020		TRANSFORMER	TRANSFORMATEUR		1
6	950021		DIODE BRIDGE	PONT DE DIODE		1
7	950022		FUSE	FUSIBLE		1
8	950023		FUSE HOLDER	PORTE FUSIBLE		1
9	950024		RELAY	RELAIS		1
10	950025		CARD CONNECTOR	CONNEXION CARTE		1
11	950048		CONTROL PANEL PLATE	PANNEAU DE CONTROLE NU		1
12	950026		ELECTRONIC CARD WITH DISPLAY	CARTE ELEC. AVEC AFFICHEUR		1
13			NOT REQUIRED	NON REQUIS	A	
14	950050		ELECTRONIC CARD FUSE	FUSIBLE DE PROTECTION CARTE		1
15	950053		24V 40A DECAL	AUTOCOLLANT 24V 40A		1
16	510010		FULMEN CHARGER 110/220V 65A	CHARGEUR 110/220V 65A FULMEN		1
17	950064		CIRCUIT BREAKER	COUPE CIRCUIT		1
18	270010		CABLE 2x1mm ² (quantity indicated in meter)	CABLE 2x1mm ² (qté indiquée en mètre)	B	1
19	270024		CABLE 3x2.5mm ² (qty indicated in meters)	CABLE 3x2.5mm ² (qté indiquée en mètre)	B	1.70
20	270020		WIRE 25mm ² (quantity indicated in meter)	CABLE 25mm ² (qté indiquée en mètre)	B	0.8
21	270020		WIRE 25mm ² (quantity indicated in meter)	CABLE 25mm ² (qté indiquée en mètre)	B	1.1

DATE : 18/03/04

OLDHAM CHARGER 110/220V 70A

MONTAGE N°/

ASSY NO : 510078 REV :

CHARGEUR 110/220V 70A OLDHAM

1/1

DET NO.	REF./PART NUMBER	VOIR/ SEE VIEW	DESCRIPTION		RE V	Qté/ Qty Req.
1	951019		NH00/80A gl FUSE	FUSIBLE NH00/80A gl		1
2	951021		32A CIRCUIT BREAKER	COUPE CIRCUIT 32A		1
3	951023		24/70V - 110/230V TRANSFORMER	TRANSFORMATEUR 24/70V - 110/230V		1
4	951025		DIODE BRIDGE PMS-70C 140x250	PONT DE DIODE PMS-70C 140x250		1
5	951026		30VA AUXILIARY TRANSFORMER	TRANSFORMATEUR AUXILIAIRE 30VA		1
6	951027		240VAC CONTACTOR	CONTACTEUR 24VAC		1
7	951028		AP 062 ELECTRONIC BOARD	CARTE ELECTRONIQUE AP 062		1
7	951032		AP 063 ELECTRONIC BOARD	CARTE ELECTRONIQUE AP 063		1
8	951029		REAR COVER	CHASSIS ARRIERE		1
9	951030		FRONT COVER	CHASSIS AVANT		1
10	951031		DECAL	AUTOCOLLANT		1

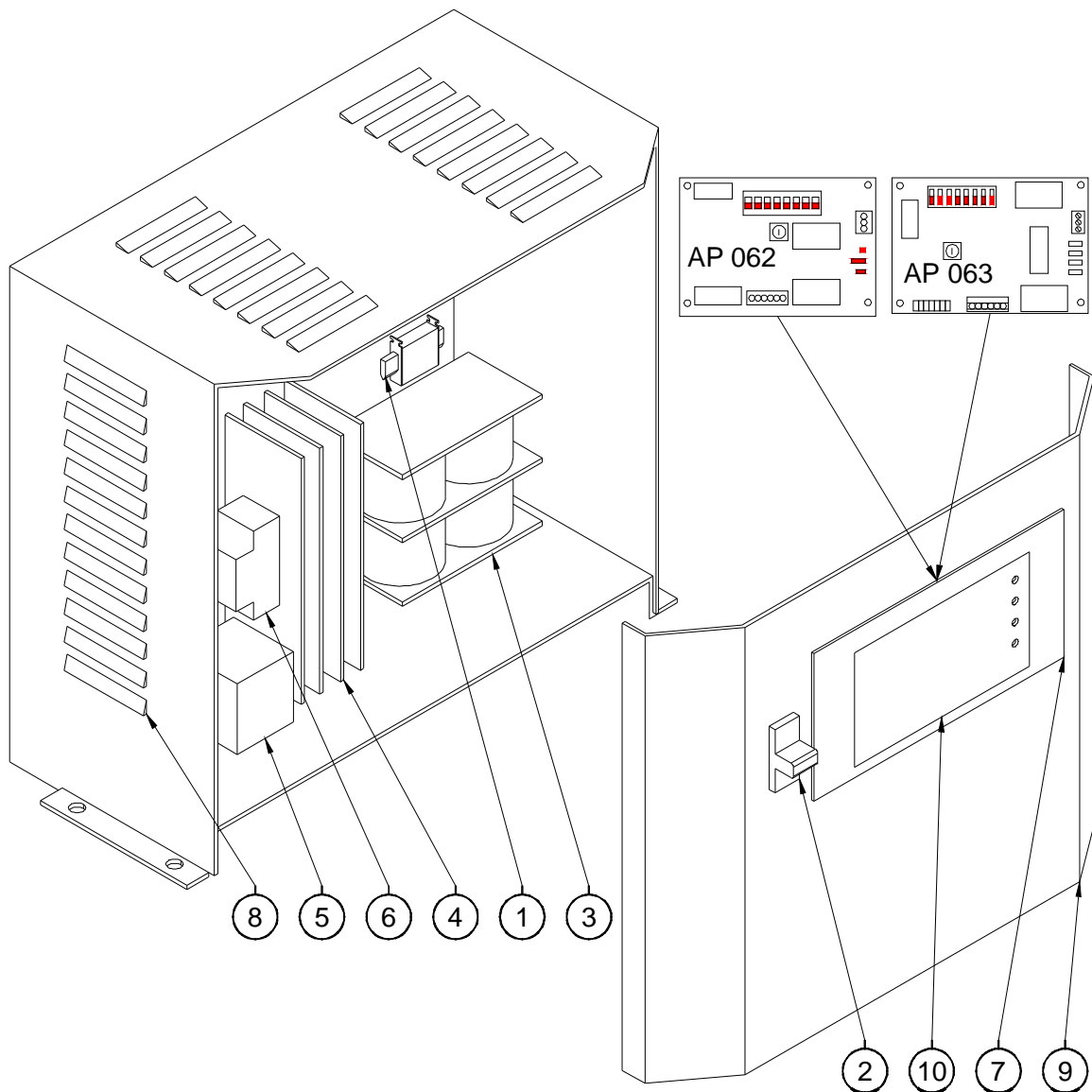

510078

DATE : 15/11/05

OLDHAM CHARGER SELECT 110/220V 70A

MONTAGE N°/

ASSY NO : 510082 REV :

CHARGEUR 70A OLDHAM SELECT 110/220V

1/1

DET NO.	REF./PART NUMBER	VOIR/SEE VIEW	DESCRIPTION		REVISION	Qté/Qty Req.
1	951019		NH00/80A gl FUSE	FUSIBLE NH00/80A gl		1
2	951021		32A CIRCUIT BREAKER	COUPE CIRCUIT 32A		1
3	951023		24/70V - 110/230V TRANSFORMER	TRANSFORMATEUR 24/70V - 110/230V		1
4	951025		DIODE BRIDGE PMS-70C 140x250	PONT DE DIODE PMS-70C 140x250		1
5	951026		30VA AUXILIARY TRANSFORMER	TRANSFORMATEUR AUXILIAIRE 30VA		1
6	951027		240VAC CONTACTOR	CONTACTEUR 24VAC		1
7	951032		AP 063 ELECTRONIC BOARD	CARTE ELECTRONIQUE AP 063		1
8	951029		REAR COVER	CHASSIS ARRIERE		1
9	951030		FRONT COVER	CHASSIS AVANT		1
10	951031		DECAL	AUTOCOLLANT		1

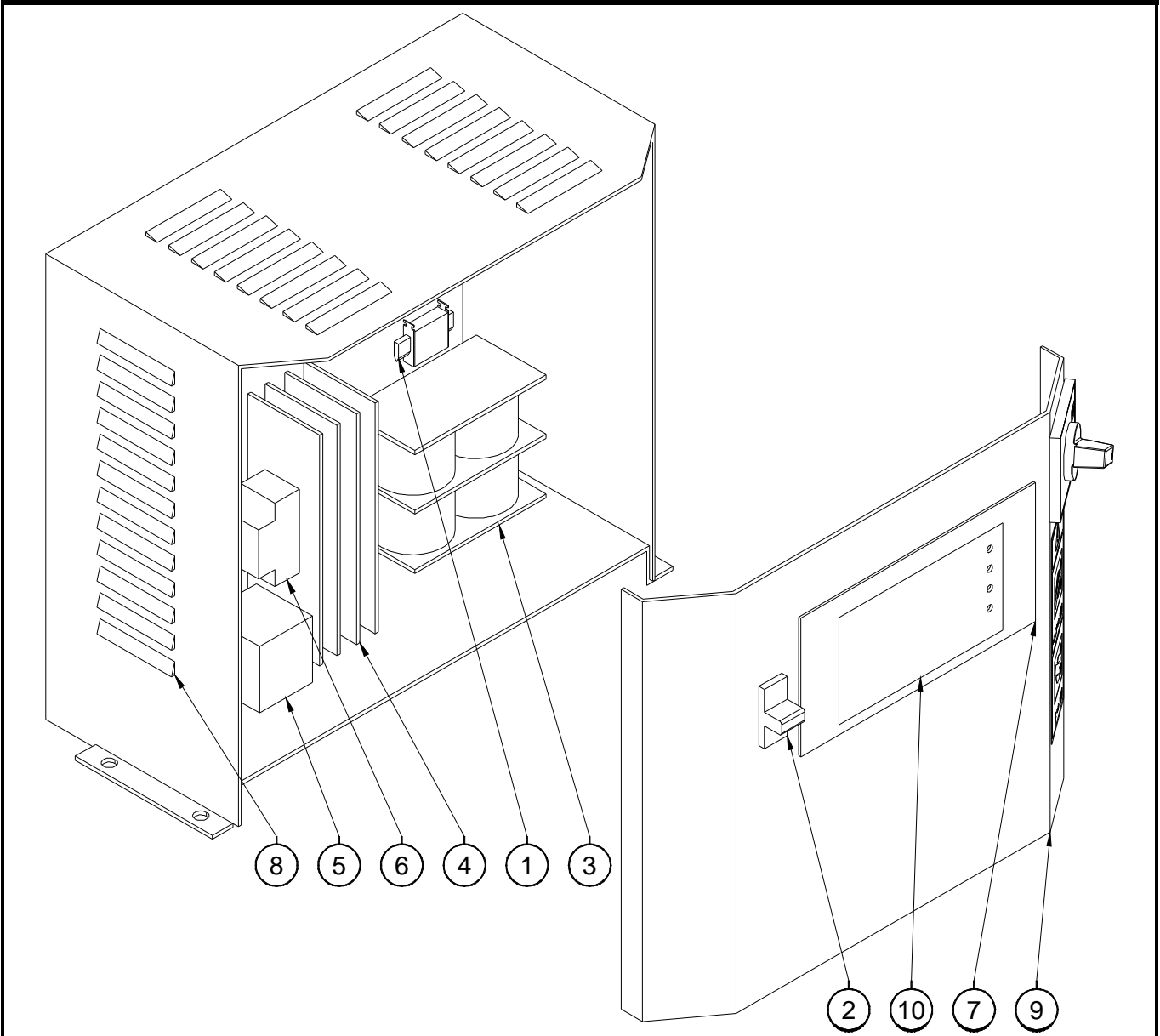

F

510082

F

ISSUE DATE : 27/05/02

80A "F7BTGR" ZIVAN CHARGER (GEL)

ISSUE REL :

ASSEMBLY N° : 510065 REV :
N° ENSEMBLE :

CHARGEUR ZIVAN 80A "F7BTGR" (GEL)

1/1

DET REP	PART NUMBER REF.	SEE VIEW VOIR VUE	DESCRIPTION		R E V	QTY QTE
1	510065		80A "F7BTGR" ZIVAN CHARGER (GEL)	CHARGEUR ZIVAN 80A "F7BTGR" (GEL)		1
2	510060		EXTERNAL INDICATOR	INDICATEUR EXTERNE		x

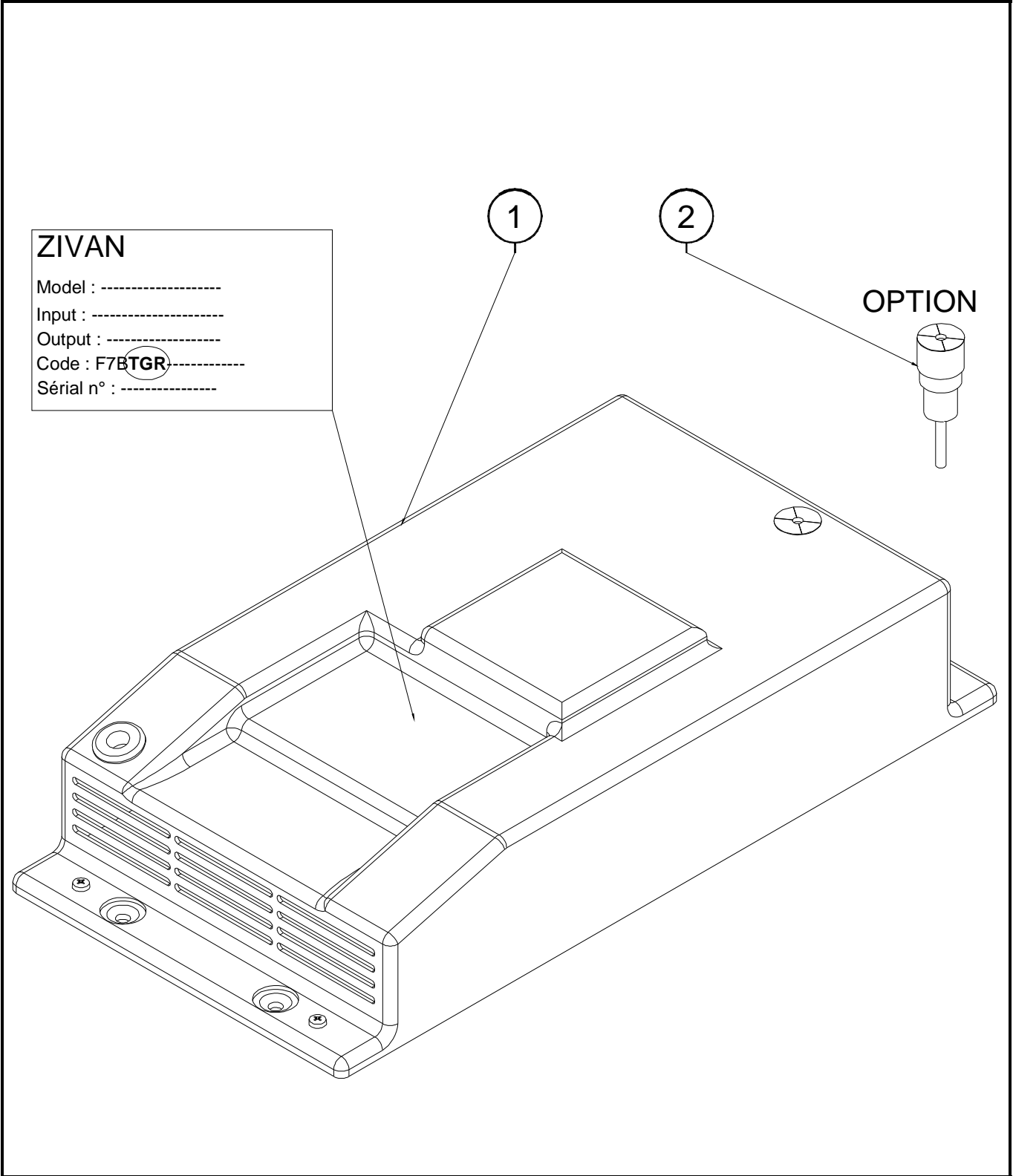

ISSUE DATE : 27/05/02

80A "F7BSTR" ZIVAN CHARGER

ISSUE REL :

ASSEMBLY N° : 510067 REV :
N° ENSEMBLE :

CHARGEUR ZIVAN 80A "F7BSTR"

1/1

DET REP	PART NUMBER REF.	SEE VIEW VOIR VUE	DESCRIPTION		R E V	QTY QTE
1	510067		80A "F7BSTR" ZIVAN CHARGER	CHARGEUR ZIVAN 80A "F7BSTR"		1
2	510060		EXTERNAL INDICATOR	INDICATEUR EXTERNE		x

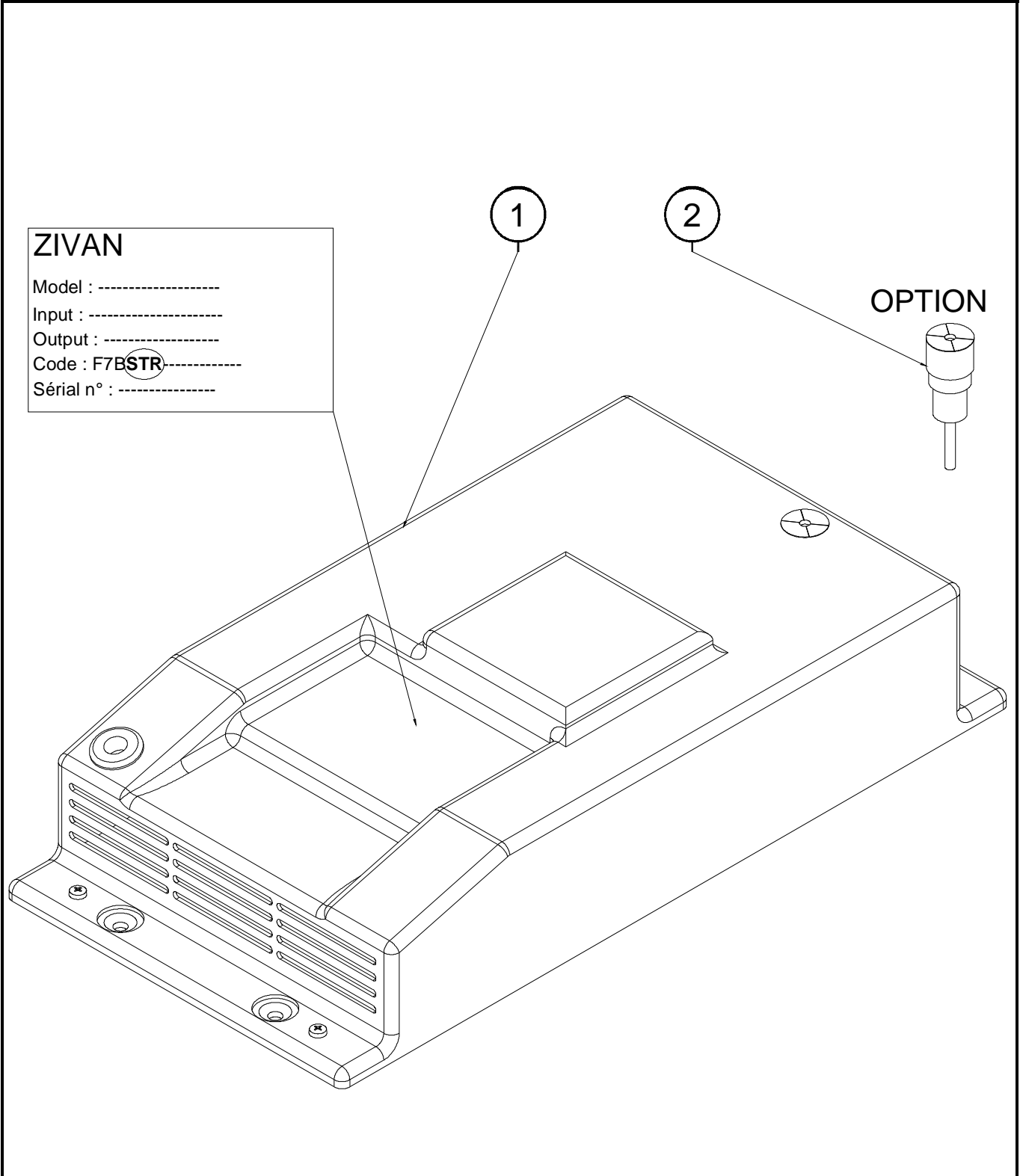

BATTERY COMPONENTS COMPOSANTS BATTERIE

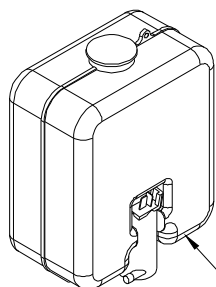

OLDHAM	FULMEN SGTE	
25	13	
24	12	

SGTE	FULMEN OLDHAM	
22	4	
23	5	

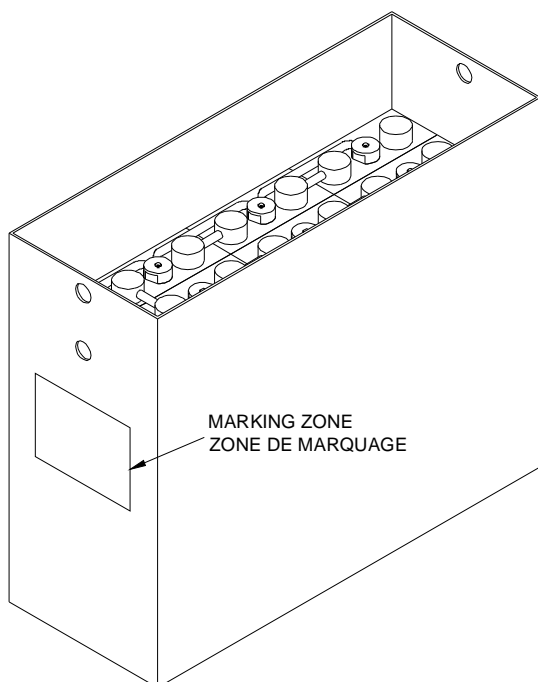
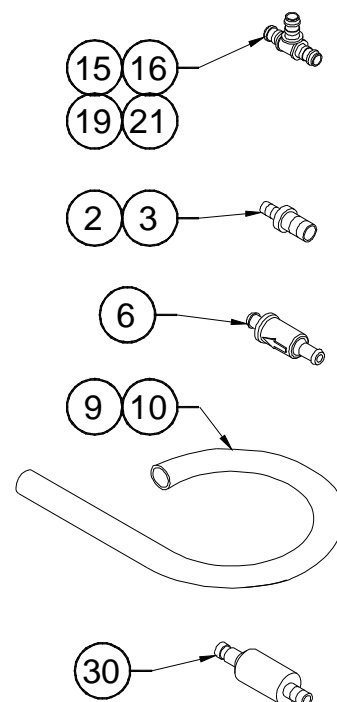
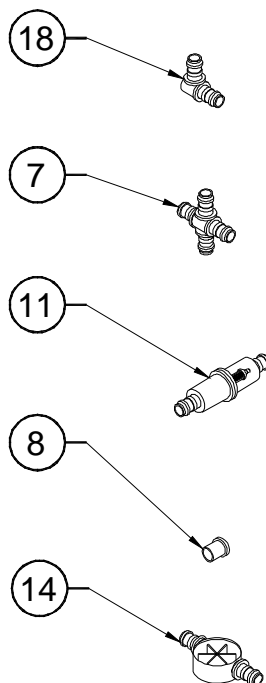
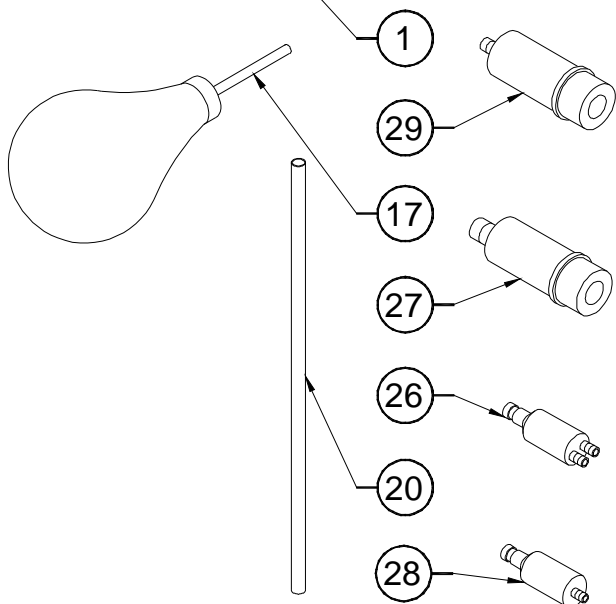

To order a battery cell (dry cell), indicate the P/N inscribed on the marking zone.

Pour commander un élément de batterie (élément sec), spécifier la référence relevée sur la zone de marquage.

ISSUE DATE : 28/05/03

BATTERY COMPONENTS

ISSUE REL :

ASSEMBLY N° : RM0092 REV :
N° ENSEMBLE :**COMPOSANTS BATTERIE**

1/1

DET REP	PART NUMBER REF.	SEE VIEW VOIR VUE	DESCRIPTION		R E V	QTY QTE
1	400058		DISTILLED WATER CAN KIT	KIT BIDON D'EAU DISTILLEE		
2	400059		4/6 REDUCTION	REDUCTION 4/6		
3	400065		6/10 REDUCTION	REDUCTION 6/10		
4	950033		BATTERY CELL LEVEL CAP	BOUCHON NIVEAU D'ELEMNT BATTERIE		
5	950035		FLOAT	FLOTTEUR		
6	400086		SCREEN WASHER CHECK VALVE	CLAPET ANTI-RETOUR LAVE-GLACE		
7	950214		CROSS 06	CROIX 06		
8	950038		TERMINAL CAP	OBTURATEUR TERMINAL		
9	950039		Ø6 PIPE (quantity indicated in meter)	TUYAU Ø 6 (quantité indiquée en mètre)		
10	950040		Ø10 PIPE (quantity indicated in meter)	TUYAU Ø10 (quantité indiquée en mètre)		
11	950041		FILTER	FILTRE		
12	950042		MALE CONNECTOR	CONNECTEUR MALE		
13	950043		FEMALE CONNECTOR	CONNECTEUR FEMELLE		
14	950044		FLOW INDICATOR Ø10	INDICATEUR DE DEBIT Ø10		
15	950045		RUN TEE 10/10/10	TE 10/10/10		
16	950046		RUN TEE 10/06/10	TE 10/06/10		
17	950047		BATTERY BULB	POIRE BATTERIE		
18	950051		90° ELBOW 06/06	COUDE 06/06		
19	950052		RUN TEE 06/06/06	TE 06/06/06		
20	950058		PIPE	TUBE		
21	950059		RUN TEE 06/10/06	TE 06/10/06		
22	950071		CELL LEVEL CAP	BOUCHON DE FLOTTEUR		
23	950072		FLOAT	FLOTTEUR		
24	950079		MALE CONNECTOR	CONNECTEUR MALE		
25	950080		FEMALE CONNECTOR	CONNECTEUR FEMELLE		
26	950148		FILTER/FLOW INDICATOR 2xØ6	FILTRE INDICATEUR DE DEBIT 2xØ6		
27	950163		FILTER FEMALE CONNECTOR Ø10	CONNECTEUR FEMELLE FILTRE Ø10		
28	950164		FILTER/FLOW INDICATOR Ø6	FILTRE INDICATEUR DE DEBIT Ø6		
29	950165		FILTER FEMALE CONNECTOR Ø6	CONNECTEUR FEMELLE FILTRE Ø6		
30	950213		FILTER / FLOW INDICATOR Ø10	FILTRE / INDICATEUR DE DEBIT Ø10		

F

RM0092

F

ISSUE DATE : 21/05/02

CHARGER CONNECTOR

ISSUE REL :

PRISE CHARGEUR

ASSEMBLY N° : RM0059 REV :
 N° ENSEMBLE :

1/1

DET REP	PART NUMBER REF.	SEE VIEW VOIR VUE	DESCRIPTION		R E V	QTY QTE
1	7364002824		US 125 VAC MALE CONNECTOR (=260276)	PRISE US 125VAC (=260276)		1
2	260213		Yellow CONNECTOR 110VAC/16A CEI, IP44	PRISE MALE Jaune 110VAC/16A CEI, IP44		1
3	250117		UK 220 VAC MALE CONNECTOR	PRISE MALE 220VAC ROYAUME UNI		1
4	260231		BLUE CONNECTOR 220VAC/16A CEI, IP44	PRISE MALE BLEUE 220VAC/16A CEI, IP44		1
5	260214		FRENCH AND GERMAN 220V CONNECTOR	PRISE 220V FRANCAISE ET ALLEMANDE		1
6	260263		BLUE CONNECTOR 220VAC/32A CEI, IP44	PRISE MALE BLEUE 220VAC/32A CEI, IP44		1
7	260266		Yellow CONNECTOR 110VAC/32A CEI, IP44	PRISE MALE Jaune 110VAC/32A CEI, IP44		1

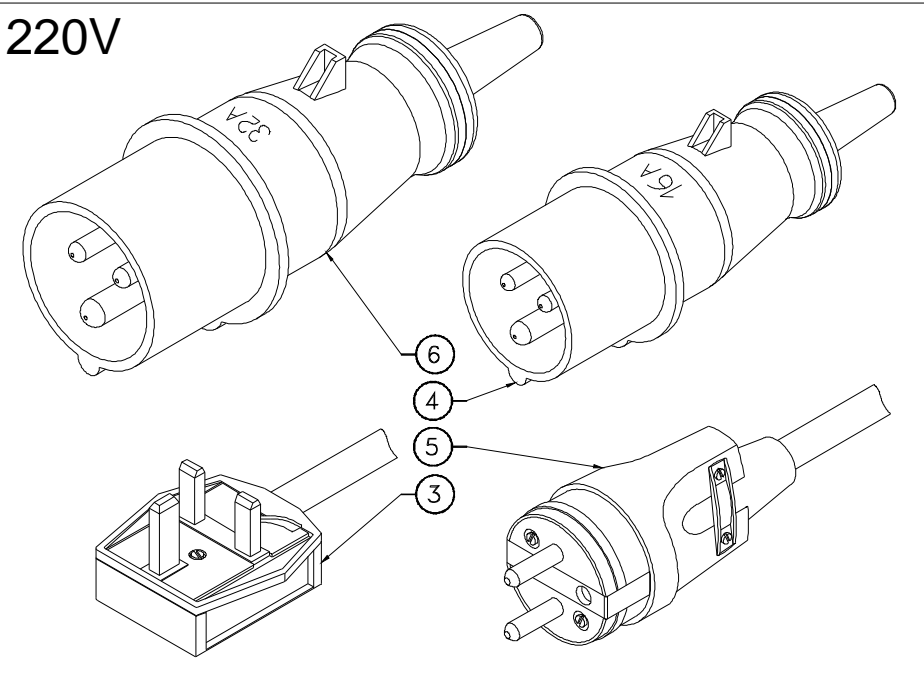
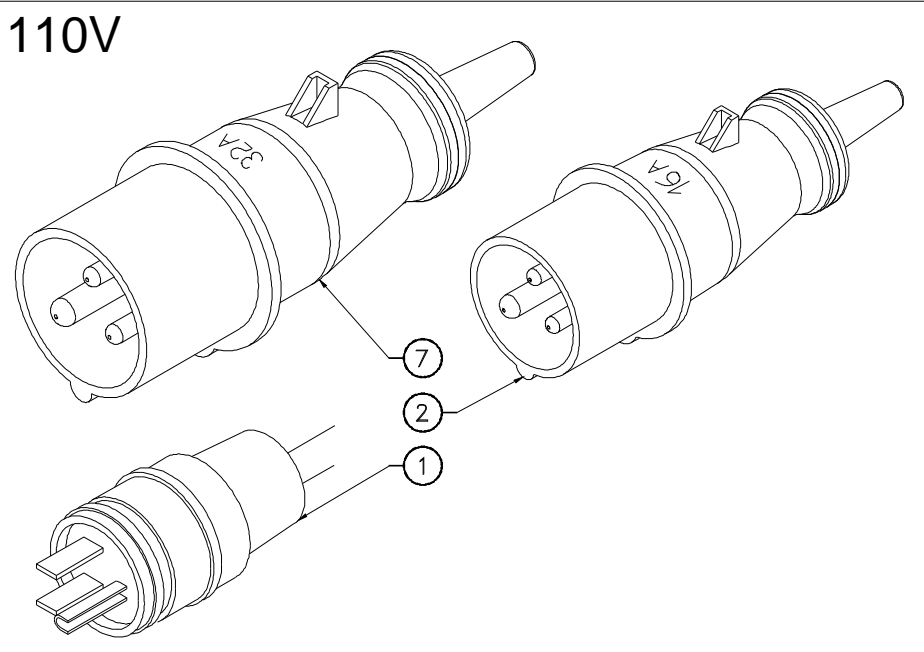

SPARE PARTS
PIECES DETACHEES

SECTION G.

DECALS INSTALL FOR AUSTRALIA.
INSTALLATION DES AUTOCOLLANTS AUSTRALIE.

Manufacturer's name plate / Plaque constructeur	AU1937
Upper control valve decal / Autocollant distributeur haut	AU0015

LARGE ALUMINIUM PLATFORM DECALS INSTALL FOR THE AUSTRALIA INSTALLATION AUTOCOLLANTS AUSTRALIE POUR GRAND PANIER ALU.

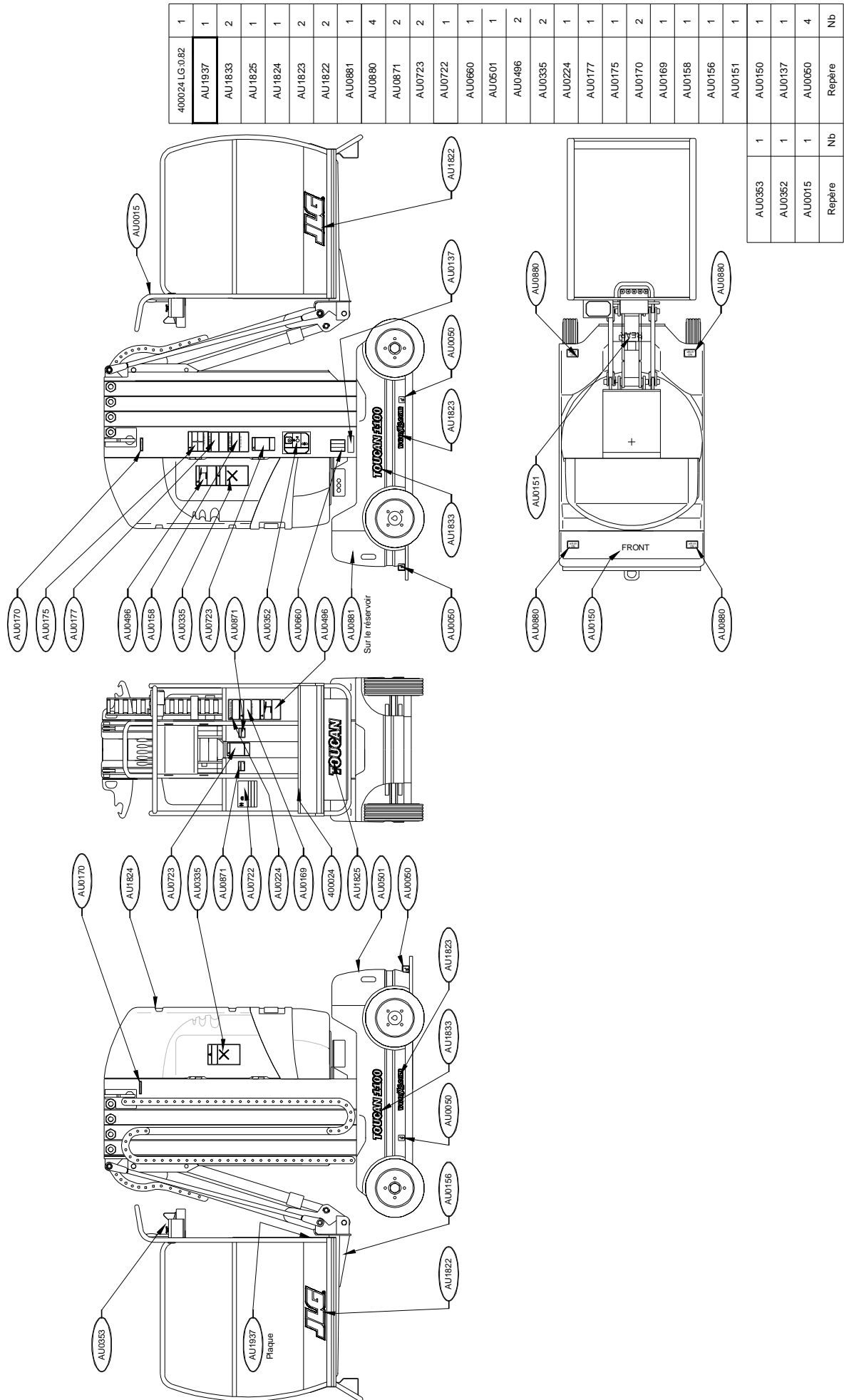

400024 LG-0.82	1
AU1937	1
AU1833	2
AU1825	1
AU1824	1
AU1823	2
AU1822	2
AU0881	1
AU0880	4
AU0871	2
AU0723	2
AU0722	1
AU0660	1
AU0501	1
AU0496	2
AU0335	2
AU0224	1
AU0177	1
AU0175	1
AU0170	2
AU0169	1
AU0158	1
AU0156	1
AU0151	1
AU0150	1
AU0137	1
AU0050	4
Repère	Nb

AU0353	1	Nb
AU0352	1	Repère
AU0015	1	Repère
Repère	Nb	

SPARE PARTS
PIECES DETACHEES

SECTION G.

CE DECALS INSTALL.
INSTALLATION DES AUTOCOLLANTS CE.

CE DECALS INSTALL INSTALLATION AUTOCOLLANTS CE

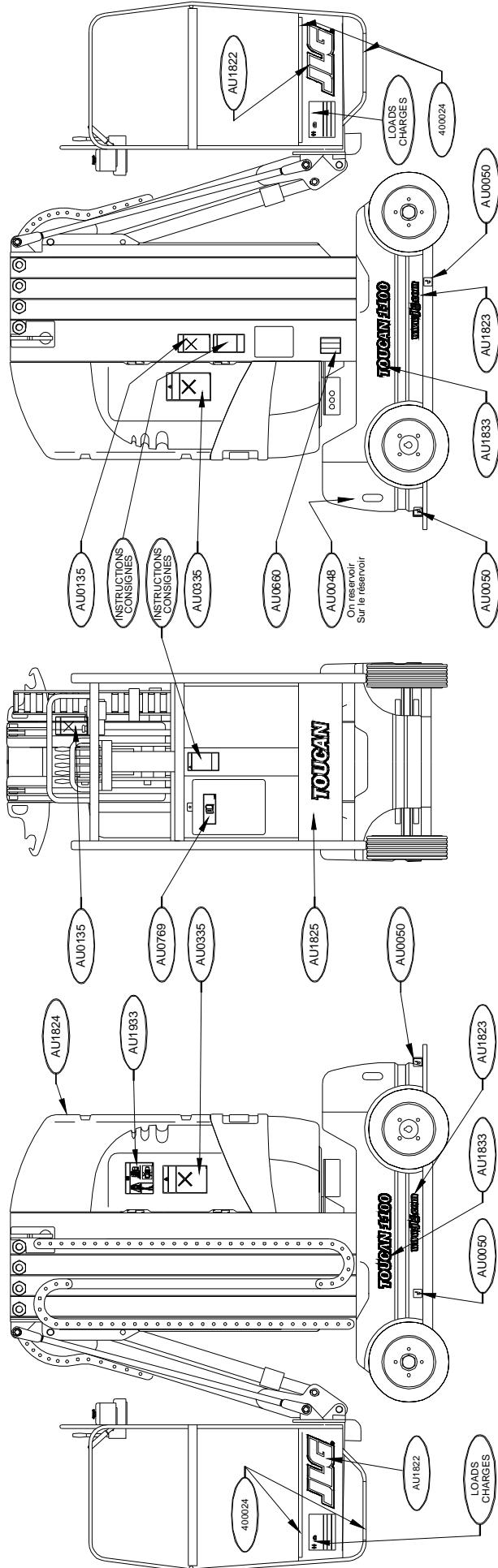

Représentation	Nb	Représentation	Nb
400024 (lg.2750)	1	AU1822	2
1706493B	1	AU1423	1
AU1933	1	AU0769	1
AU1833	2	AU0660	1
AU1825	1	AU0335	2
AU1824	1	AU0135	2
AU1823	2	AU0050	4
Repère	Nb	AU0048	1
		Repère	Nb

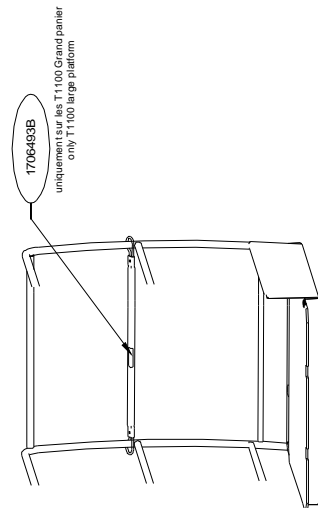
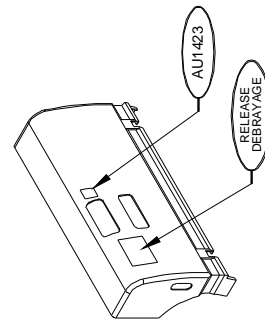

ALL CE MODELS DECALS INSTALL INSTALLATION AUTOCOLLANTS POUR TOUS MODELES CE

		STANDARD PLATFORM / PANIER STANDARD			LARGE ALUMINIUM PLATFORM / GRAND PANIER ALU.		
		LOAD / CHARGE x2	INSTRUCTIONS / CONSIGNES x2	RELEASE / DEBRAYAGE x1	LOAD / CHARGE x1	INSTRUCTIONS / CONSIGNES x2	RELEASE / DEBRAYAGE x1
Danemark/Denmark	DK	AU0990	AU1576	AU0739	AU0990	AU1576	AU0739
		PA0816			PA0827		
Dutch/Hollande	NL	AU0684	AU1580	AU0653	AU0684	AU1580	AU0653
		PA0820			PA0912		
Finland/Finlande	FIN	AU1033	AU1578	AU1035			
		PA0818					
France	F	AU0663	AU1569	AU0475	AU0663	AU1569	AU0475
		PA0811			PA0812		
Germany/Allemagne Austria/Autriche	D A	AU0677	AU1575	AU0620	AU0677	AU1575	AU0620
		PA0815			PA0826		
Greece/Grèce	GR	AU1539	AU1579	AU1540	AU1539	AU1579	AU1540
		PA0819			PA0819		
Italy/Italie	I	AU0692	AU1581	AU0688	AU0692	AU1581	AU0688
		PA0821			PA0832		
Norway/Norvège	N	AU0750	AU1582	AU0748	AU0750	AU1582	AU0748
		PA0822			PA0833		
Poland/Pologne	PL	AU1114	AU1583	AU0626			
		PA0823					
Portuguese/Portugal	P	AU1805	AU1804	AU1036	AU1805	AU1804	AU1036
		PA0931			PA0932		
Spain/Espagne	E	AU0824	AU1577	AU0659	AU0824	AU1577	AU0659
		PA0817			PA0828		
Sweden/Suède	S	AU1001	AU1584	AU0925	AU1001	AU1584	AU0925
		PA0824			PA0835		
Switzerland/Suisse	F D	AU0663	AU1569	AU0475	AU0663	AU1569	AU0475
		AU0677	AU1575	AU0620	AU0677	AU1575	AU0620
United Kingdoms/ Royaume uni	GB	AU0674	AU1574	AU0501	AU0674	AU1574	AU0501
		PA0814			PA0825		

PAxxxx = COMPLETE KIT / JEU COMPLET

Manufacturer's name plate / Plaque constructeur	Toucan 1100A	AU1849
	Toucan 1100C	AU1850
Upper control valve decal / Autocollant distributeur haut		AU0015

SPARE PARTS
PIECES DETACHEES

SECTION H.

STANDARD PLATFORM INSTALL.
INSTALLATION DU PANIER STANDARD.

STANDARD PLATFORM INSTALL INSTALLATION DU PANIER STANDARD

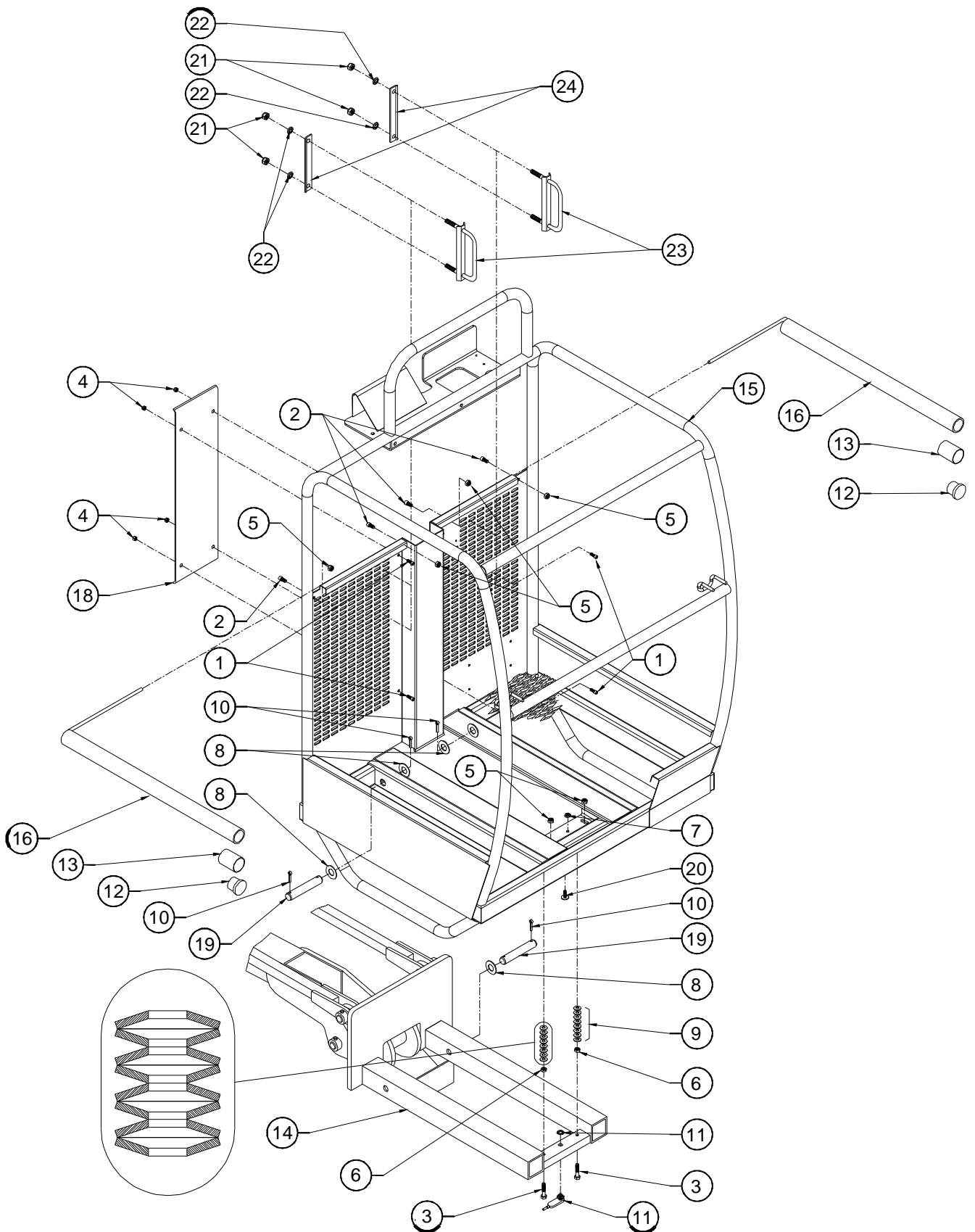

DATE : 16/06/01

STANDARD PLATFORM INSTALL

MONTAGE N°/

ASSY NO : SP0220 REV : B

INSTALLATION PANIER STANDARD

1/1

DET NO.	REF./PART NUMBER	VOIR/ SEE VIEW	DESCRIPTION		R E V	Qté/ Qty Req.
1	000015		M06x16 8.8 SOCKET HEAD MACH SCREW	VIS CHC M06x16 8.8 BI FT		4
2	000018		M08x16 8.8 SOCKET HEAD MACH SCREW	VIS CHC M08x16 8.8 BI FT		4
3	100029		M08x40 8.8 HEX HEAD MACHINE SCREW	VIS H M08x40 8.8 BI FT		2
4	110003		M06 GR. 8.8 LOCK NUT	ECROU FREIN M6 8.8 BI		4
5	110004		M08 GR. 8.8 LOCK NUT	ECROU FREIN M8 8.8 BI		6
6	110016		M08 GR. 8.8 HEX NUT	ECROU H M08 8.8 BI		2
7	110022		M08 GR. 8.8 FLAT HEX NUT	ECROU Hm M08 8.8 ZI		1
8	120003		M20 WASHER	RONDELLE M20 BI		4
9	120005		Ø20x8.2x0.8 SPRING WASHER	RONDELLE RESSORT Ø20x8.2x0.8 BR		16
10	140001		COTTER PIN Ø4.5x40	GOUPILLE FENDUE Ø4.5x40		4
11	260015		OVERLOAD SENSOR	DETECTEUR DE SURCHARGE		1
12	400048		CAP	BOUCHON	B	2
13	280003		Black Heat Shrink Sleeve 38/12 (qty in meter)	GAINE THERMO NOIRE 38/12 (qté en mètre)	B	2x0.05
14	DL0125		PLATFORM SUPPORT	SUPPORT PANIER		1
15	DL0563		STANDARD PLATFORM	PANIER STANDARD	B	1
16	DL0564		FLAP	PORTILLON	B	2
17			NOT REQUIRED	NON REQUIS	B	
18	ST0304		HOSES PLATE	TOLE FLEXIBLES		1
19	US0211		PLATFORM MOUNTING PIN	AXE DE PANIER	A	1
20	US0236		SETTING SCREW	VIS DE REGLAGE		1
21	110005	OPTION	M10 GR. 8.8 LOCK NUT	ECROU FREIN M10 8.8 BI		4
22	120011	OPTION	dD 10x22 LOCK WASHER	RONDELLE CONTACT dD 10x22 BI		4
23	ST0567	OPTION	LANYARD ATTACHMENT	CROCHET DE SECURITE		2
24	108FP023	OPTION	LANYARD ATTACHMENT PLATE	PLAT DE CROCHET		2

H

SP0220

H

SPARE PARTS
PIECES DETACHEES

SECTION H.

LARGE ALUMINIUM PLATFORM INSTALL.
INSTALLATION DU GRAND PANIER ALUMINIUM.

LARGE ALUMINIUM PLATFORM INSTALL INSTALLATION DU GRAND PANIER ALUMINIUM

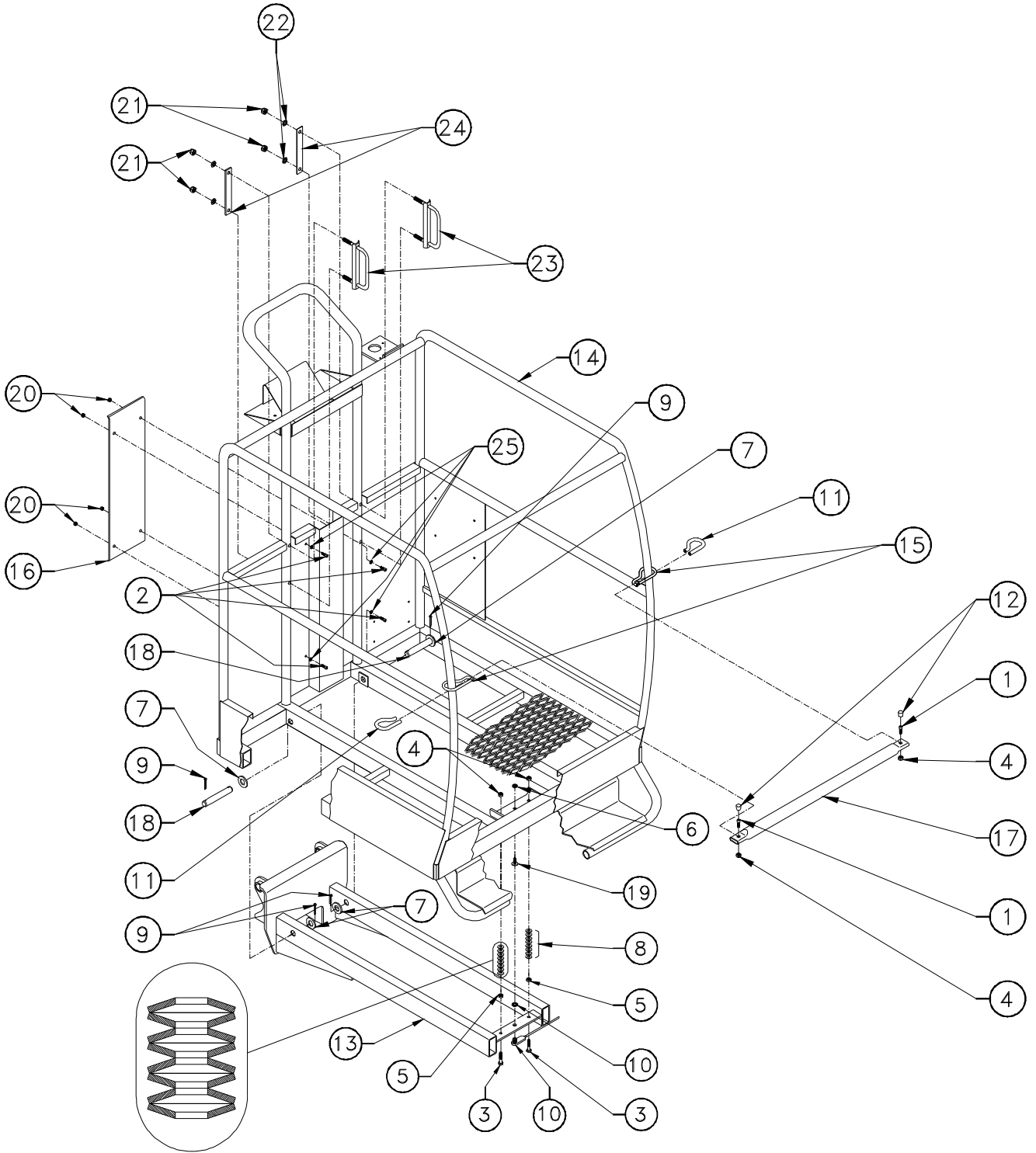

DATE : 12/05/99

LARGE ALUMINIUM PLATFORM INSTALL

MONTAGE N°/

ASSY NO : SP0216 REV : A **INSTALLATION GRAND PANIER ALU**

1/1

DET NO	REF./PART NUMBER	VOIR/SEE VIEW	DESCRIPTION		REVIEW	Qté/Qty Req.
1	000006		M08x20 8.8 SOCKET HEAD MACH SCREW	VIS CHC M08x20 8.8 BI FT		2
2	000015		M06x16 8.8 SOCKET HEAD MACH SCREW	VIS CHC M06x16 8.8 BI FT		4
3	100029		M08x40 8.8 HEX HEAD MACHINE SCREW	VIS H M08x40 8.8 BI FT		2
4	110004		M08 GR. 8.8 LOCK NUT	ECROU FREIN M8 8.8 BI		4
5	110016		M08 GR. 8.8 HEX NUT	ECROU H M08 8.8 BI		2
6	110022		M08 GR. 8.8 FLAT HEX NUT	ECROU Hm M08 8.8 BI		1
7	120003		M20 WASHER	RONDELLE M20 BI		4
8	120005		Ø20x8.2x0.8 SPRING WASHER	RONDELLE RESSORT Ø20x8.2x0.8 BI		16
9	140001		COTTER PIN Ø4.5x40	GOUPILLE FENDUE Ø4.5x40		4
10	260015		OVERLOAD SENSOR	DETECTEUR DE SURCHARGE		1
11	280023		PROTECTION SLEEVE (quantity in meter)	GAINE DE PROTECTION (qté en mètre)		2
12	400026		RUBBER CAP	CHAPEAU DE VIS		2
13	DL0383		PLATFORM SUPPORT	SUPPORT PANIER		1
14	DL0453		LARGE ALUMINIUM PLATFORM INSTALL	INSTALLATION DU GRAND PANIER ALU.	A	1
15	ST0736		SLIDING GATE LOOP	ANNEAU PORTILLON		2
16	ST0757		HOSES PLATE	TOLE FLEXIBLES		1
17	ST0763		PLATFORM SLIDING GATE	PORTILLON		1
18	US0188		PLATFORM MOUNTING PIN	AXE DE PANIER		2
19	US0236		SETTING SCREW	VIS DE REGLAGE		1
20	110003		M06 GR. 8.8 LOCK NUT	ECROU FREIN M6 8.8 BI		4
21	110005		M10 GR. 8.8 LOCK NUT	ECROU FREIN M10 8.8 BI		4
22	120011		dD 10x22 LOCK WASHER	RONDELLE CONTACT dD 10x22 BI		4
23	ST0567		LANYARD ATTACHMENT	CROCHET DE SECURITE		2
24	ST0568		LANYARD ATTACHMENT PLATE	PLAT DE CROCHET		2
25	120009		dD 06x14 LOCK WASHER	RONDELLE CONTACT dD 06x14 BI		4
			THE PARTS NO.21 TO 24 ARE OPTIONS			
			LES PIECES NO.21 A 24 SONT EN OPTION			

H

SP0216

H

SPARE PARTS
PIECES DETACHEES

OPTIONS



**SPARE PARTS
PIECES DETACHEES**

OPTION.

**8 m DRIVE CUTTING INSTALL.
INSTALLATION DE LA COUPURE TRANSLATION
8 m.**

8 m DRIVE CUTTING INSTALL INSTALLATION DE LA COUPURE TRANSLATION 8 m

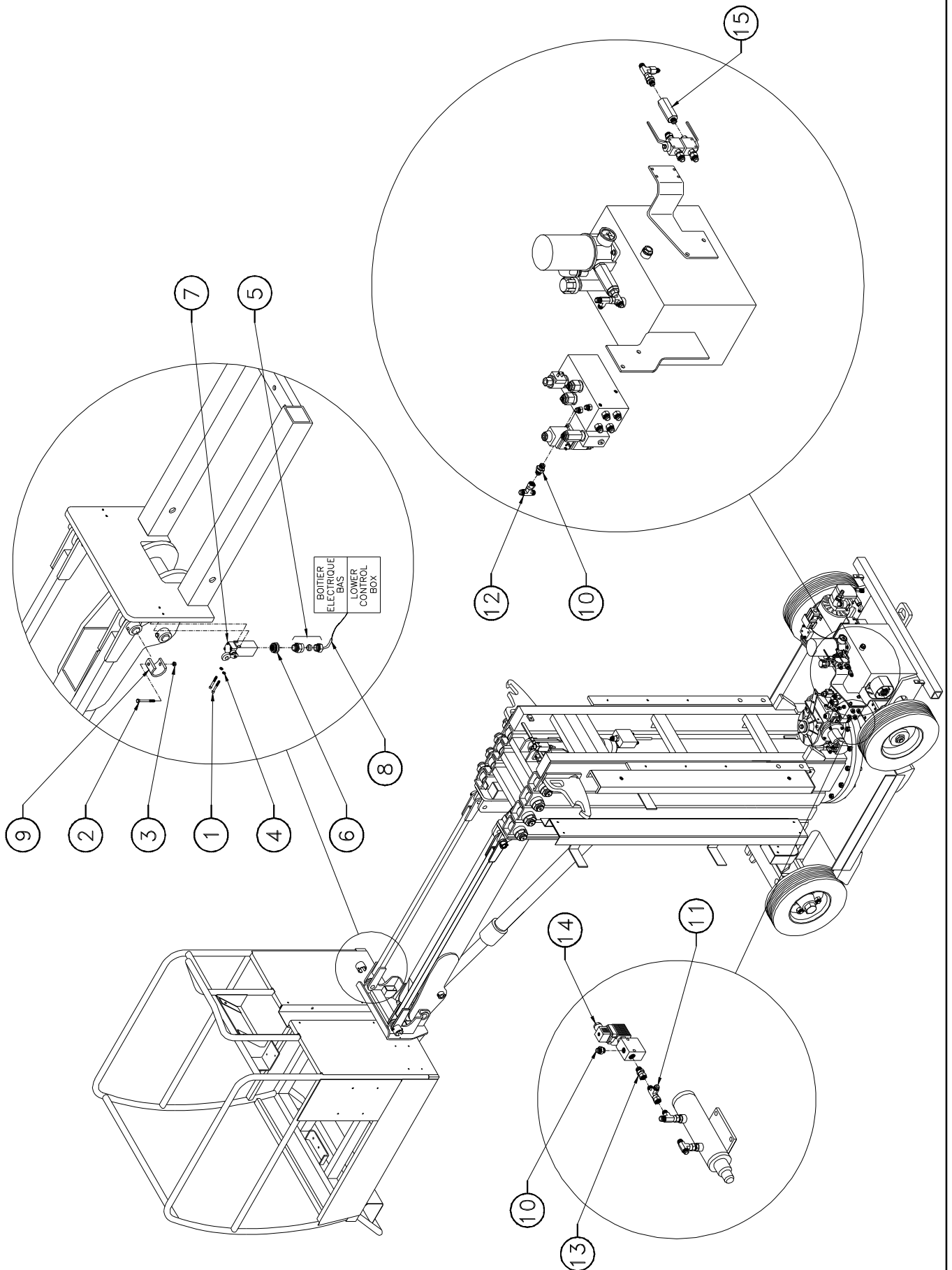

DATE : 28/01/98

SOLENOID

MONTAGE N°/

ASSY NO : 310033 REV :

ELECTROVANNE

1/1

DET NO.	REF./PART NUMBER	VOIR/ SEE VIEW	DESCRIPTION		R E V	Qté/ Qty Req.
1	960032		SOLENOID BLOCK	BLOC ELECTROVANNE		1
2	910005		24 VDC COIL	BOBINE ELECTROCLAPET 24 VDC		1
3	900080		CARTRIDGE VALVE	ELECTROCLAPET		1
4	900075		SEAL KIT	KIT DE JOINTS		1
5	900087		HIRSHMAN CONNECTOR	CONNECTEUR HIRSHMAN		1

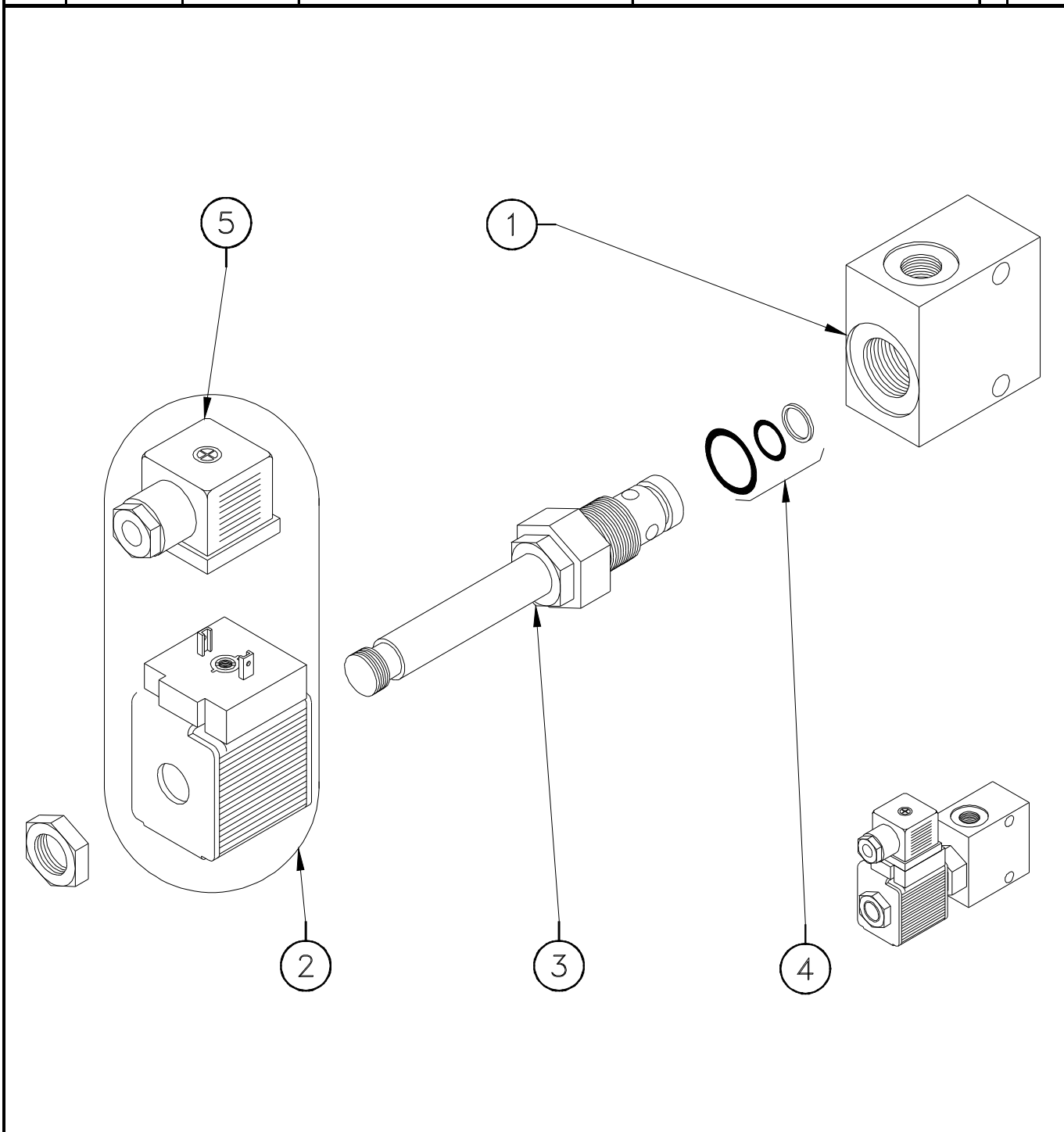

**SPARE PARTS
PIECES DETACHEES**

OPTION.

**9 m DRIVE CUTTING INSTALL.
INSTALLATION DE LA COUPURE TRANSLATION
9 m.**

9 m DRIVE CUTTING INSTALL INSTALLATION DE LA COUPURE TRANSLATION 9 m

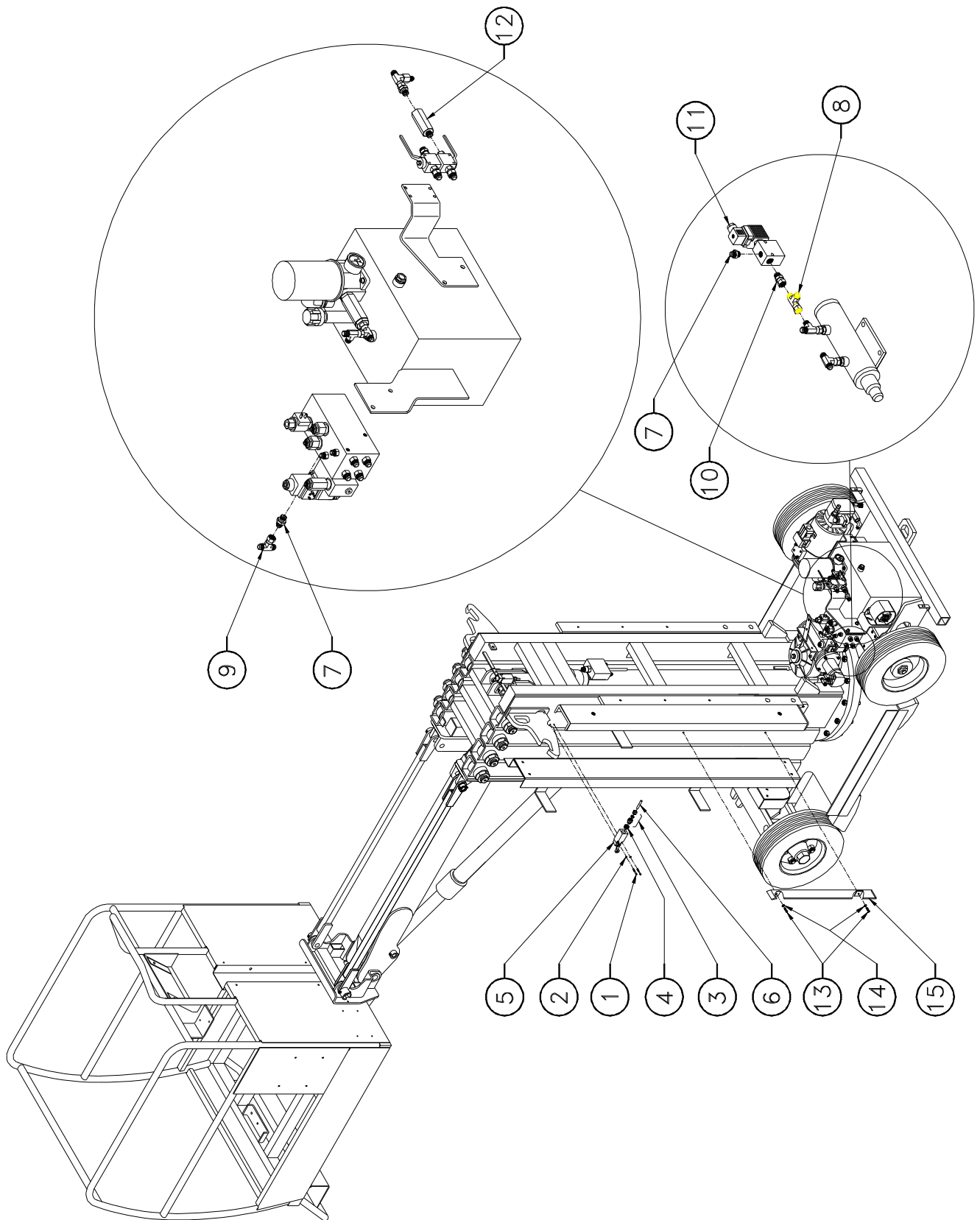

DATE : 28/01/98

SOLENOID

MONTAGE N°/

ASSY NO : 310033 REV :

ELECTROVANNE

1/1

DET NO.	REF./PART NUMBER	VOIR/SEE VIEW	DESCRIPTION		REVISION	Qté/Qty Req.
1	960032		SOLENOID BLOCK	BLOC ELECTROVANNE		1
2	910005		24 VDC COIL	BOBINE ELECTROCLAPET 24 VDC		1
3	900080		CARTRIDGE VALVE	ELECTROCLAPET		1
4	900075		SEAL KIT	KIT DE JOINTS		1
5	900087		HIRSHMAN CONNECTOR	CONNECTEUR HIRSHMAN		1

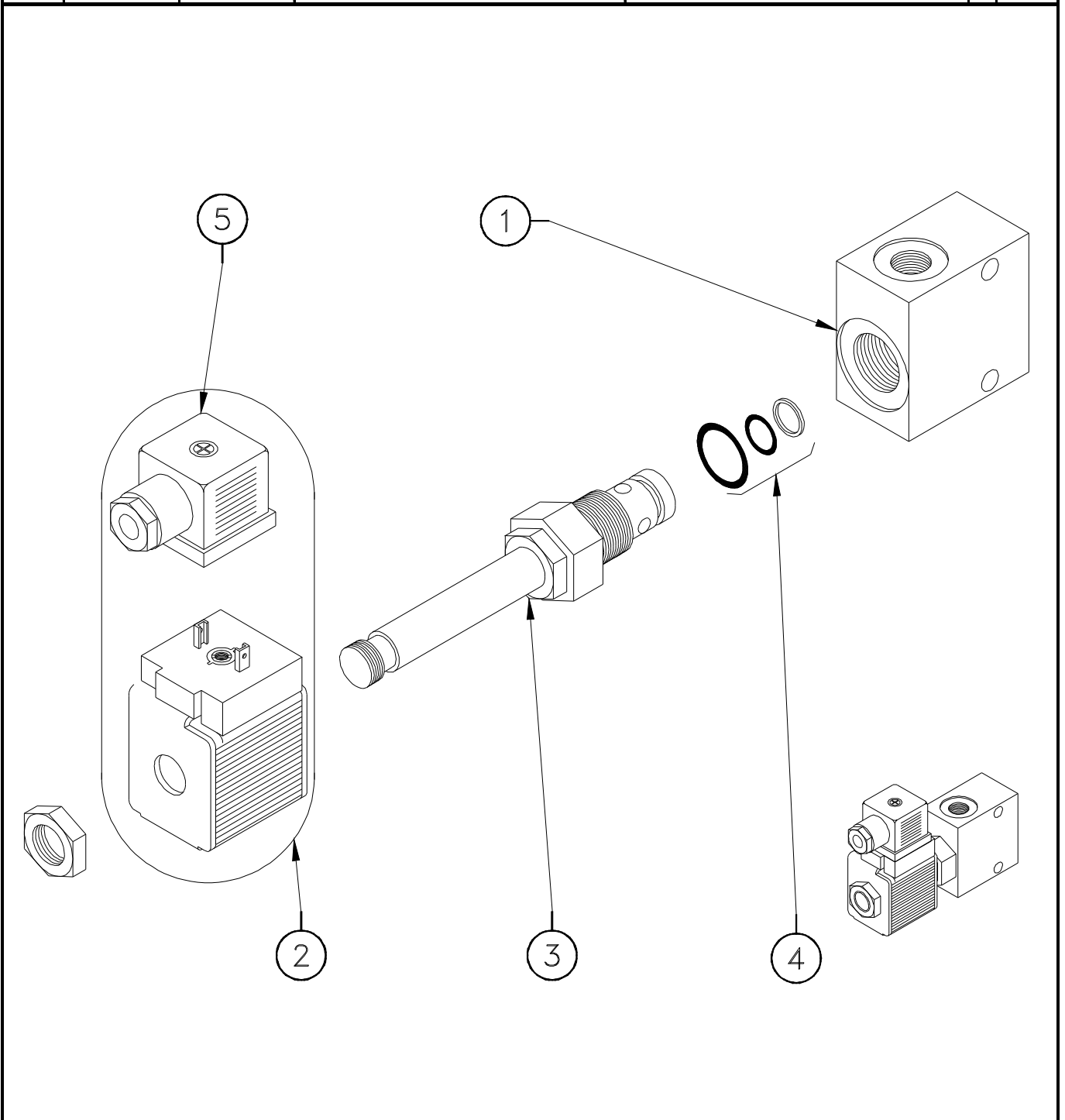

UPPER CONTROL VALVE GRID INSTALL INSTALLATION GRILLE SUR DISTRIBUTEUR HAUT

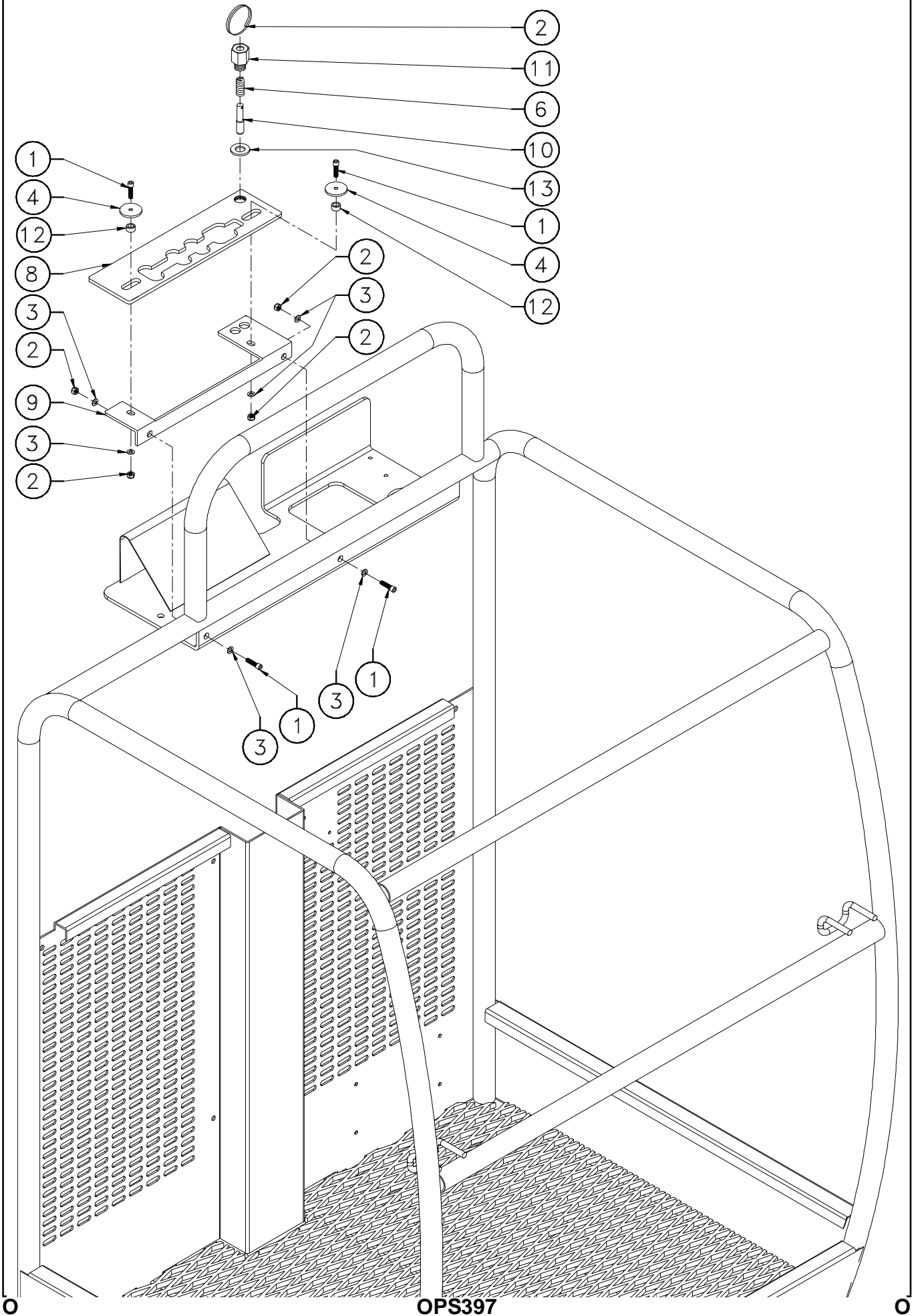

SPARE PARTS
PIECES DETACHEES

OPTION.

FLASHING LIGHT INSTALL.
INSTALLATION LAMPES CLIGNOTANTES.

FLASHING LIGHT INSTALL INSTALLATION LAMPES CLIGNOTANTES

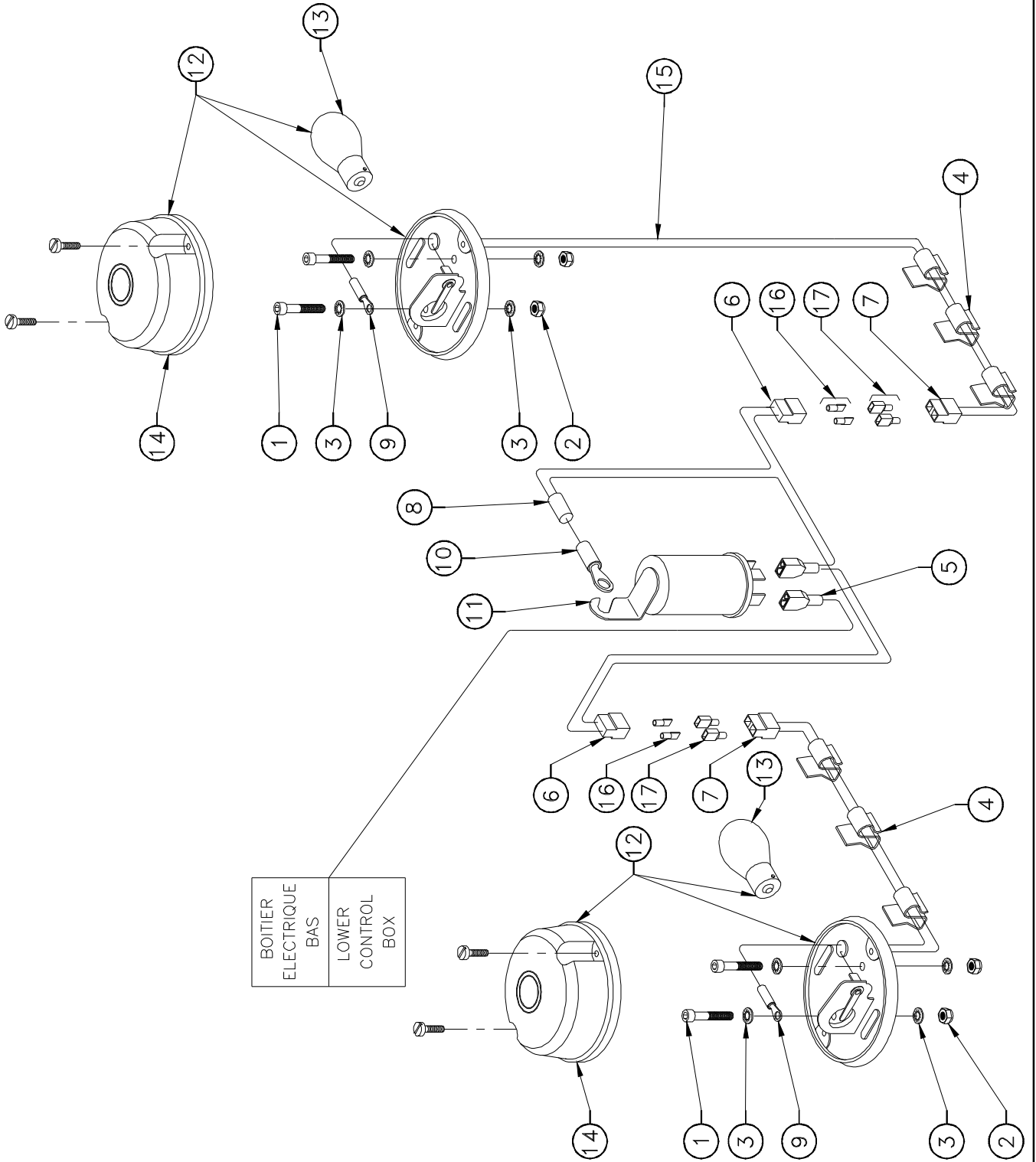

DATE : 22/01/98

FLASHING LIGHT INSTALL

MONTAGE N°/

ASSY NO : SP2007 REV :

**INSTALLATION LAMPES
CLIGNOTANTES**

1/1

DET NO.	REF./PART NUMBER	VOIR/ SEE VIEW	DESCRIPTION	R E V	Qté/ Qty Req.
1	000020		M04x20 8.8 SOCKET HEAD MACH SCREW		4
2	110001		M04 GR. 8.8 LOCK NUT		4
3	120024		M04 LOCK WASHER		8
4	190022		FIXATION CLIP		6
5	250027		BLUE RECEPTACLE TER. 6.3 - 1.5-2.5mm		2
6	250032		2 POSITIONS CAP HOUSING		2
7	250033		2 POSITIONS PLUG HOUSING		2
8	250037		SPLICE TERMINAL 1-2.5mm ²		2
9	250081		M04 EYELET TERMINAL 0.25-1mm ²		2
10	250084		M08 EYELET TERMINAL 0.25-1mm ²		1
11	260021		FLASHER UNIT		1
12	260022		FLASHING LIGHT KIT		2
13	260023		24V 21W BUBLE		2
14	260026		ORANGE CAP		2
15	270009		CABLE 2x1.5mm ² (quantity indicated in met		1
16	250034		BLADE TERMINAL 6.3mm		4
17	250035		RECEPTACLE TERMINAL 6.3mm		4

SPARE PARTS
PIECES DETACHEES

OPTION.

DISPLAY PANEL INSTALL.
INSTALLATION PORTE AFFICHE.

SMALL PLATFORM DISPLAY PANEL ASSEMBLY ASSEMBLAGE PORTE AFFICHE PETITE PLATE-FORME

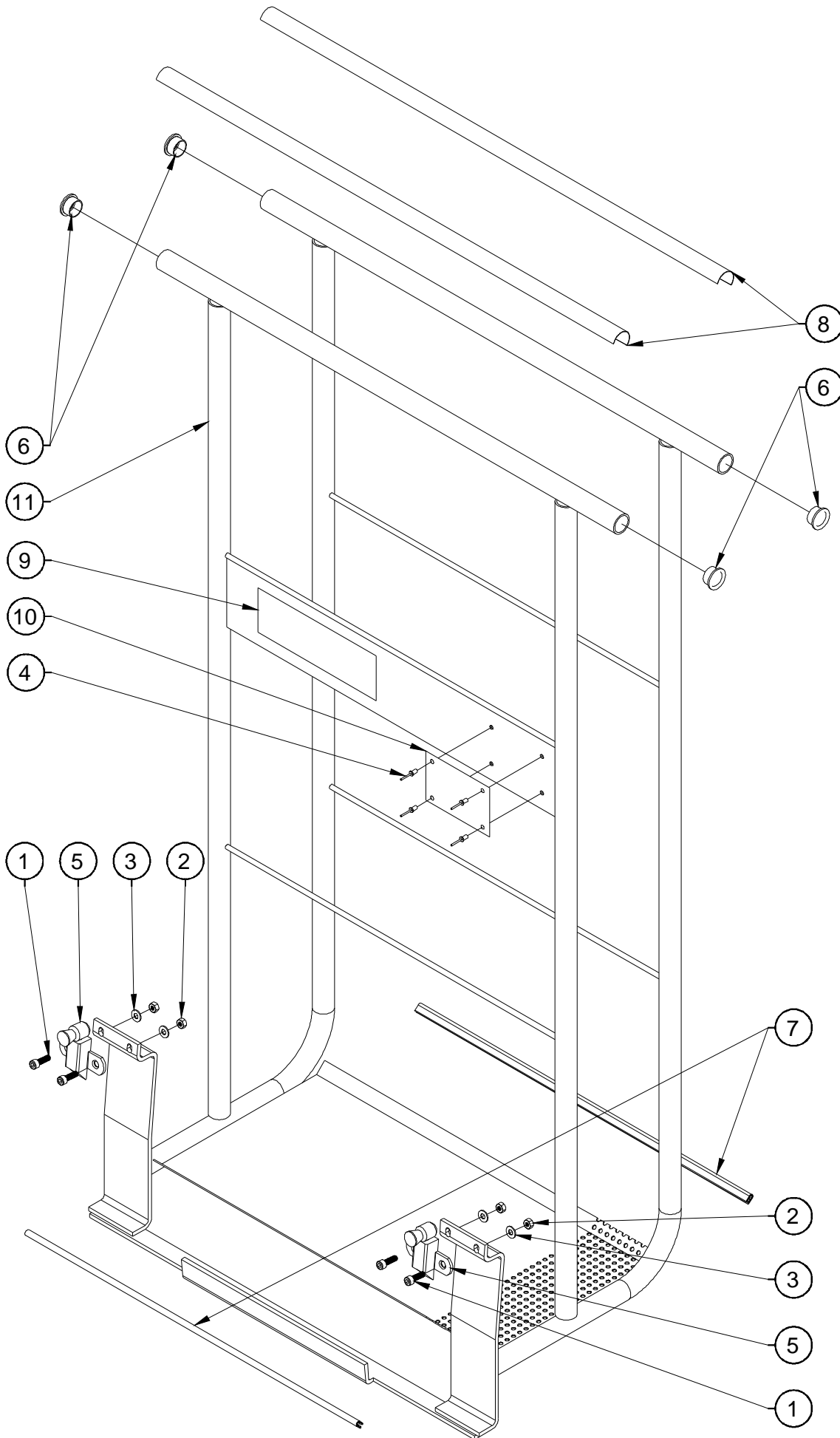

LARGE PLATFORM DISPLAY PANEL ASSEMBLY

ASSEMBLAGE PORTE AFFICHE GRANDE PLATE-FORME

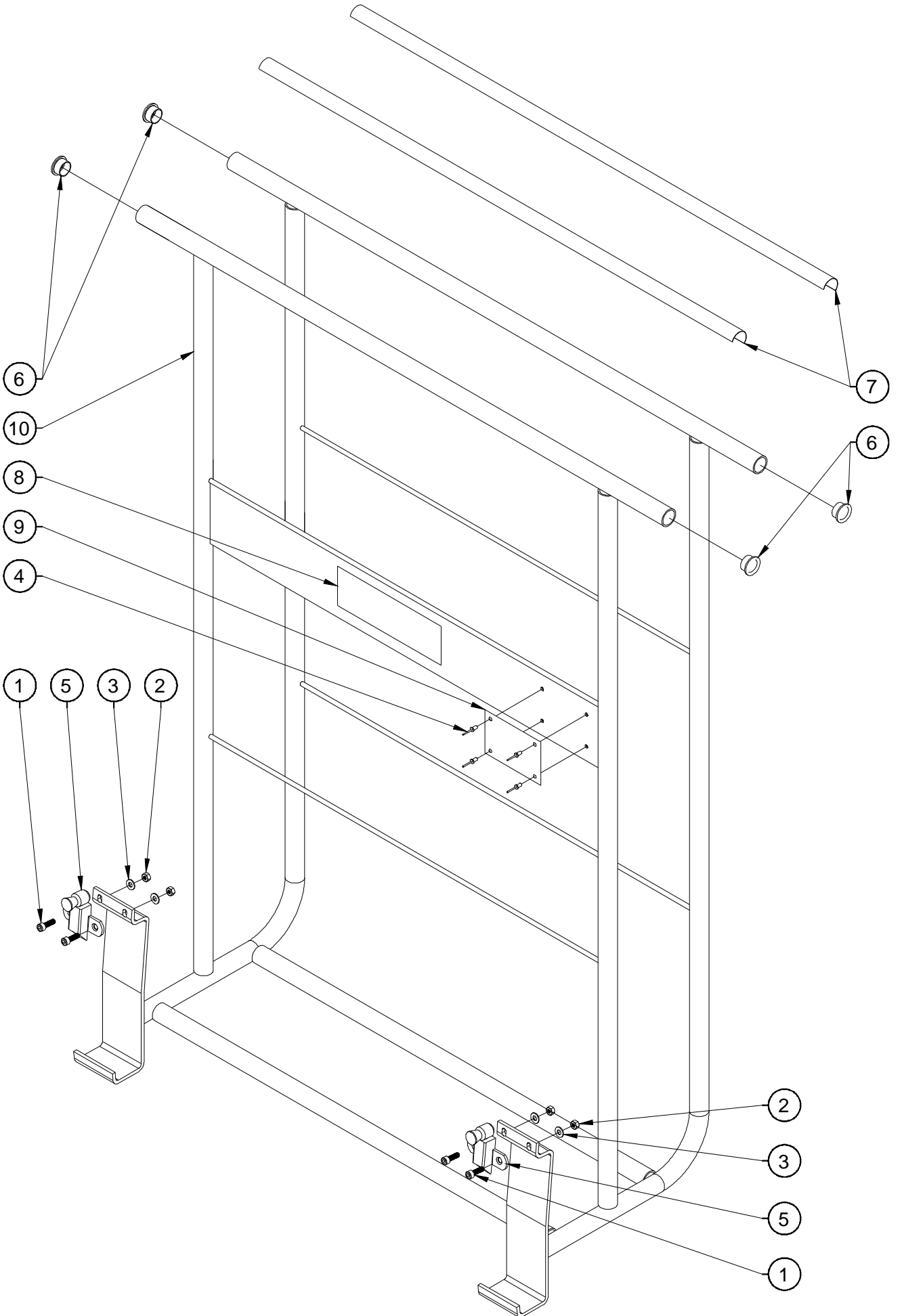

SPARE PARTS
PIECES DETACHEES

OPTION.

220VAC SOCKET INSTALL.
INSTALLATION PRISE 220V.



220VAC SOCKET INSTALL INSTALLATION PRISE 220V

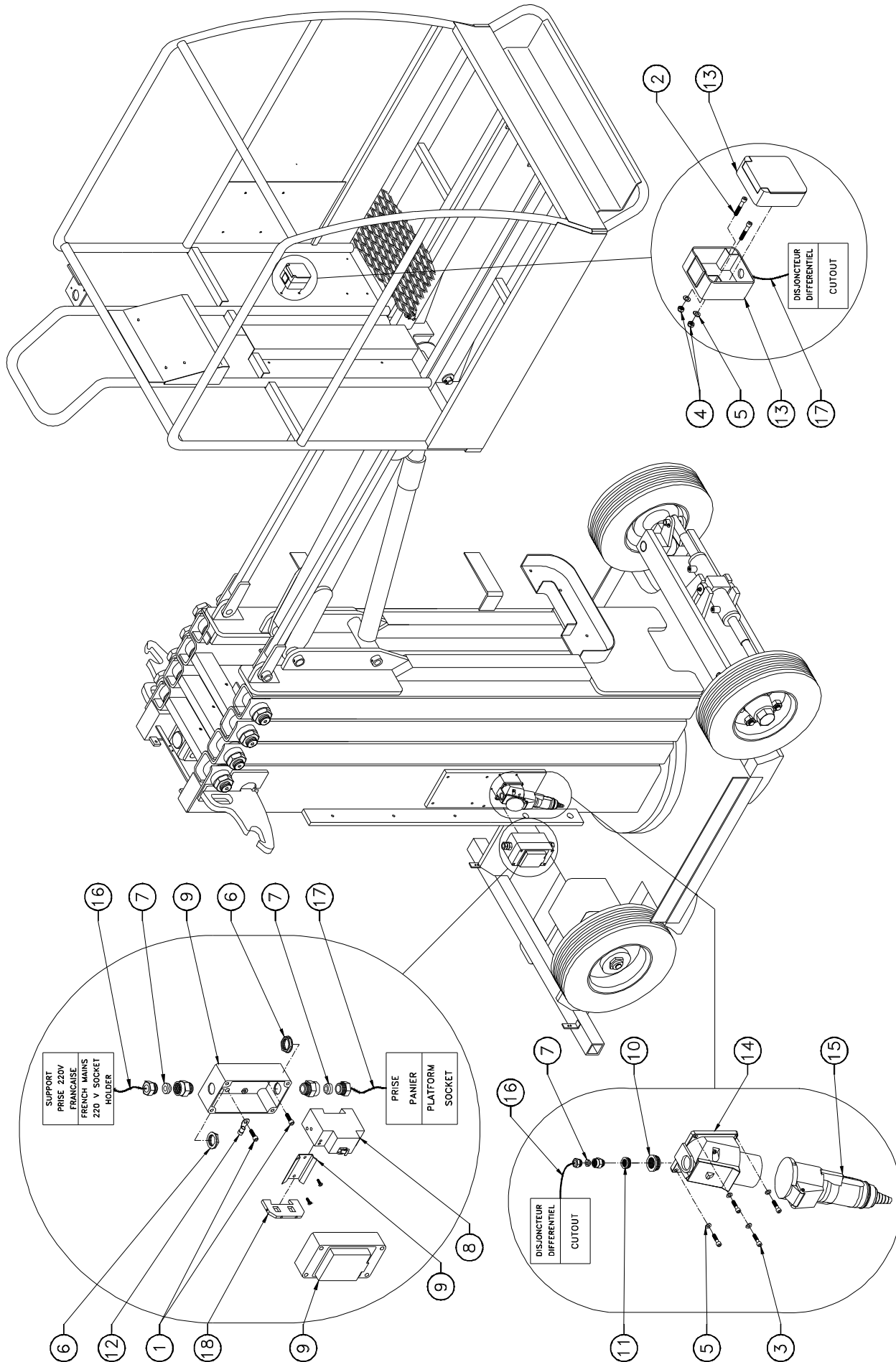

CROSS REFERENCE CHART

	Pages	Main assembly Assemblage supérieur
310066	10-2	SP0212
520014	9-5-1	SP0218
900058	9-5-1-1	520014
952040	9-2-1-1-2	952074
952073	9-2-1-1-1	952074
952074	9-2-1-1	SP0729
FL0142	6-7	SP0222
SE0495	7-4-1	SP0203-204-205-206-212
SP0202	7	
SP0203	7-1	SP0202
SP0204	7-2	SP0202
SP0205	7-3	SP0202
SP0206	7-4	SP0202
SP0207	9-1	SP0214
SP0208	9-2	SP0214
SP0210	2	SP0241
SP0211	4	SP0228
SP0212	10	SP0214
SP0213	9-3	SP0214
SP0214	9	SP1133
SP0215	9-4	SP0214
SP0218	9-5	SP0214
SP0219	11	SP0212
SP0221	6-1	SP0222
SP0222	6	SP0225
SP0223	3-1	SP0228
SP0224	3-2	SP0228
SP0225	5	SP0211
SP0228	3	SP0210
SP0236	6-2	SP0222
SP0237	6-3	SP0222
SP0238	6-4	SP0222
SP0239	6-5	SP0222
SP0240	6-6	SP0222
SP0241	1	
SP0244	9-2-2	SP0208
SP0729	9-2-1	SP0208
SP1031	7-4-4	SP0205
SP1047	7-4-3	SP0204
SP1048	7-4-2	SP0203
SP1105	10-1	SP0212
SP1133	8	SP0202