



MODELS TOUCAN 1100



SPARE PARTS MANUAL MANUEL DE PIÈCES DÉTACHÉES

U.S.A.
JLG INDUSTRIES, INC
1 JLG Drive
McConnellsburg
PA 17233-9533
Tél : (717) 485-5161
Fax : (717) 485-6417

C.E.
JLG Industries,
Kilmartin Place,
Tannochside Park
Uddingston, Scotland G71 5PH
Tel : +44(0)1698 811005
Fax : +44(0)1698 811055

FRANCE
JLG France SAS
Z.I. de Failliet
BP 20 - 47400 TONNEINS
France
Tel : +33 553 84 85 11
Fax : +33 553 79 06 87

Updated : 03-2008

**MA0132-07
English/French**



DISTRIBUTOR STAMP / CACHET DISTRIBUTEUR

MACHINE SERIAL NUMBER :
NUMERO DE SERIE MACHINE :

TOUCAN 1100A N° _____

TOUCAN 1100C N° _____



Cert. N° FM 40826

Edition 03-2008
MA0132-07

SPARE PARTS

TO ORDER PARTS

IT IS ESSENTIAL TO SUPPLY THE FOLLOWING INFORMATION ON PARTS ORDERS SO THAT YOUR ORDER CAN BE PROPERLY EXPEDITED.

1. Give model and serial number of your machine. This information is found on the serial number plate mounted on the platform.
2. Give complete information on the parts requested including the part number, description, and quantity.
3. Give the specific major unit for which the item is required, such as : frame, mast, cylinder, platform, control box, etc.
4. Give complete "ship-to" address and specify the exact method of shipment wanted.
5. Specify the urgency of the parts order by designating the priority (emergency or stock).

NOTE

When placing telephone order, please record with whom you spoke and date, so that follow-up telephone conversations are processed without confusion.

PIECES DETACHEES

POUR PASSER COMMANDE

AFIN QUE VOTRE COMMANDE SOIT CORRECTEMENT TRAITEE, IL EST NECESSAIRE DE FOURNIR LES INFORMATIONS SUIVANTES SUR LE BON DE COMMANDE.

1. Noter le modèle et le numéro de série de votre machine. Ces informations se trouvent sur la plaque constructeur qui est fixée sur le panier.
2. Noter entièrement les renseignements sur les articles en commande : référence de la pièce, description et quantité.
3. Indiquer l'unité principale pour laquelle la pièce est commandée : châssis, mât, vérin, plate-forme, boîtier de commande, etc...
4. Noter l'adresse complète du destinataire et indiquer le mode d'expédition souhaité.
5. Spécifier l'urgence des pièces commandées en indiquant leur priorité (urgence ou stock).

NOTE

Si vous passez une commande téléphonique, noter le nom de votre interlocuteur et la date afin que le suivi de votre entretien se fasse sans confusion.

TOUCAN 1100



CHARGER
CHARGEUR
SECTION 4

MAST 1
MAT 1
SECTION 10

MAST CYLINDER
VERIN DE MAT
SECTION 6

MAST 2-3-4-5
MATS 2-3-4-5
SECTION 7

POWER BRIDGE
CHAINES PORTE CABLES
SECTION 5

BATTERY PACK
BATTERIE
ANNEXE F

UPPER CONTROL VALVE
DISTRIBUTEUR HAUT
SECTION 6

UPPER CONTROL BOX
BOITIER ELECTRIQUE HAUT
SECTION 3

LOWER CONTROL BOX
BOITIER ELECTRIQUE BAS
SECTION 3

JIB
BRAS
SECTION 11

FLAP
PORTILLON
ANNEXE H

COUNTERWEIGHT
CONTREPOIDS
SECTION 2

FOOT SWITCH
PEDALE
SECTION 3

CENTRALE/PUMP-MOTOR
RESERVOIR/OIL TANK
DRIVE MANIFOLD BLOC
BLOC DE TRANSLATION
SECTION 9

PLATFORM
PANIER
ANNEXE H

BRAKE CYLINDER
VERINS FREIN
SECTION 9

JIB CYLINDER
VERIN DE BRAS
SECTION 6

ALARM
ALARME
SECTION 3

COVERS
CAPOTS
SECTION 1

SWING MOTOR
MOTEUR D'ORIENTATION
SECTION 10

LOWER VALVE
DISTRIBUTEUR BAS
SECTION 6

HAND PUMP
POMPE A MAIN
SECTION 6

WHEELS
ROUES
SECTION 9

STEERING
DIRECTION
SECTION 9

TILT SENSOR
DETECTEUR DE DEVERS
SECTION 3

FRAME
CHASSIS
SECTION 9

TABLE OF CONTENTS		TABLE DES MATIERES	
COVERS INSTALL	1	INSTALLATION CAPOTS	1
COUNTERWEIGHT INSTALL	2	INSTALLATION CONTREPOIDS	2
ELECTRICAL INSTALL	3	INSTALLATION ELECTRIQUE	3
POWER CIRCUIT	3-1	CIRCUIT DE PUISSANCE	3-1
CONTROL CIRCUIT	3-2	CIRCUIT DE COMMANDE	3-2
MATE-N-LOK CONNECTORS	3-2-1	CONNECTEURS MATE-N-LOK	3-2-1
CONNECTORS ON HARNESS ASSY	3-2-2	CONNECTEURS SUR FAISCEAUX	3-2-2
LOWER CONTROL BOX ASSEMBLY	3-2-3	ASSEMBLAGE BOITIER BAS	3-2-3
UPPER CONTROL BOX ASSEMBLY	3-2-4	ASSEMBLAGE BOITIER HAUT	3-2-4
CHARGER INSTALL	4	INSTALLATION CHARGEUR	4
CHANNEL AND POWER BRIDGE INSTALL	5	INSTALLATION CHAINES PORTE CABLES	5
HYDRAULIC INSTALL	6	INSTALLATION HYDRAULIQUE	6
MAST CYLINDER ASSEMBLY	6-1	ASSEMBLAGE VERIN DE MAT	6-1
LOWER VALVE ASSEMBLY	6-2	ASSEMBLAGE DISTRIBUTEUR BAS	6-2
BULKHEAD ASSEMBLY	6-3	ASSEMBLAGE TRAVERSEE DE CLOISON	6-3
JIB CYLINDER ASSEMBLY	6-4	ASSEMBLAGE VERIN DE BRAS	6-4
JIB FLOW CONTROL ASSEMBLY	6-5	ASSEMBLAGE ETRANGLEUR BRAS	6-5
HAND PUMP ASSEMBLY	6-6	ASSEMBLAGE POMPE A MAIN	6-6
HYDRAULIC SCHEMATIC	6-7	SCHEMA HYDRAULIQUE	6-7
MAST INSTALL	7	INSTALLATION DU MAT	7
MAST 2 ASSEMBLY	7-1	ASSEMBLAGE MAT 2	7-1
PULLEY ASSEMBLY LH12-66	7-1-1	ASSEMBLAGE SUPPORT POULIE LH12-66	7-1-1
MAST 3 ASSEMBLY	7-2	ASSEMBLAGE MAT 3	7-2
PULLEY ASSEMBLY LL12-66	7-2-1	ASSEMBLAGE SUPPORT POULIE LL12-66	7-2-1
MAST 4 ASSEMBLY	7-3	ASSEMBLAGE MAT 4	7-3
PULLEY ASSEMBLY LL10-40	7-3-1	ASSEMBLAGE SUPPORT POULIE LL10-40	7-3-1
MAST 5 ASSEMBLY	7-4	ASSEMBLAGE MAT 5	7-4
TURNTABLE INSTALL	8	INSTALLATION TOURELLE	8
FRAME INSTALL	9	INSTALLATION CHASSIS	9
HYDRAULIC RESERVOIR INSTALL	9-1	INSTALLATION DU RESERVOIR	9-1
3 SPEEDS MANIFOLD ASSEMBLY	9-1-1	ASSEMBLAGE BLOC 3 VITESSES	9-1-1
3 SPEEDS MANIFOLD	9-1-1-1	BLOC 3 VITESSES	9-1-1-1
PUMP/MOTOR INSTALL	9-2	INSTALLATION DE LA CENTRALE	9-2
5.5cc/rev POWER UNIT	9-2-1	CENTRALE 5.5cm ³ /tr	9-2-1
5.5 cc/rev PUMP	9-2-1-1	POMPE 5.5 cm ³ /tr	9-2-1-1
MAST 1 ASSEMBLY	10	ASSEMBLAGE MAT 1	10
SWING DRIVE ASSEMBLY	10-1	ASSEMBLAGE REDUCT. D'ORIENTATION	10-1
JIB INSTALL	11	INSTALLATION BRAS	11
APPENDIX	16	ANNEXES	16
OPTIONS	17	OPTIONS	17
CROSS REFERENCE CHART	LAST PAGE	TABLEAU DE CORRESPONDANCE	DERNIERE PAGE

SPARE PARTS
PIECES DETACHEES

SECTION 1.

COVERS INSTALL.
INSTALLATION CAPOTS.



COVERS INSTALL INSTALLATION CAPOTS

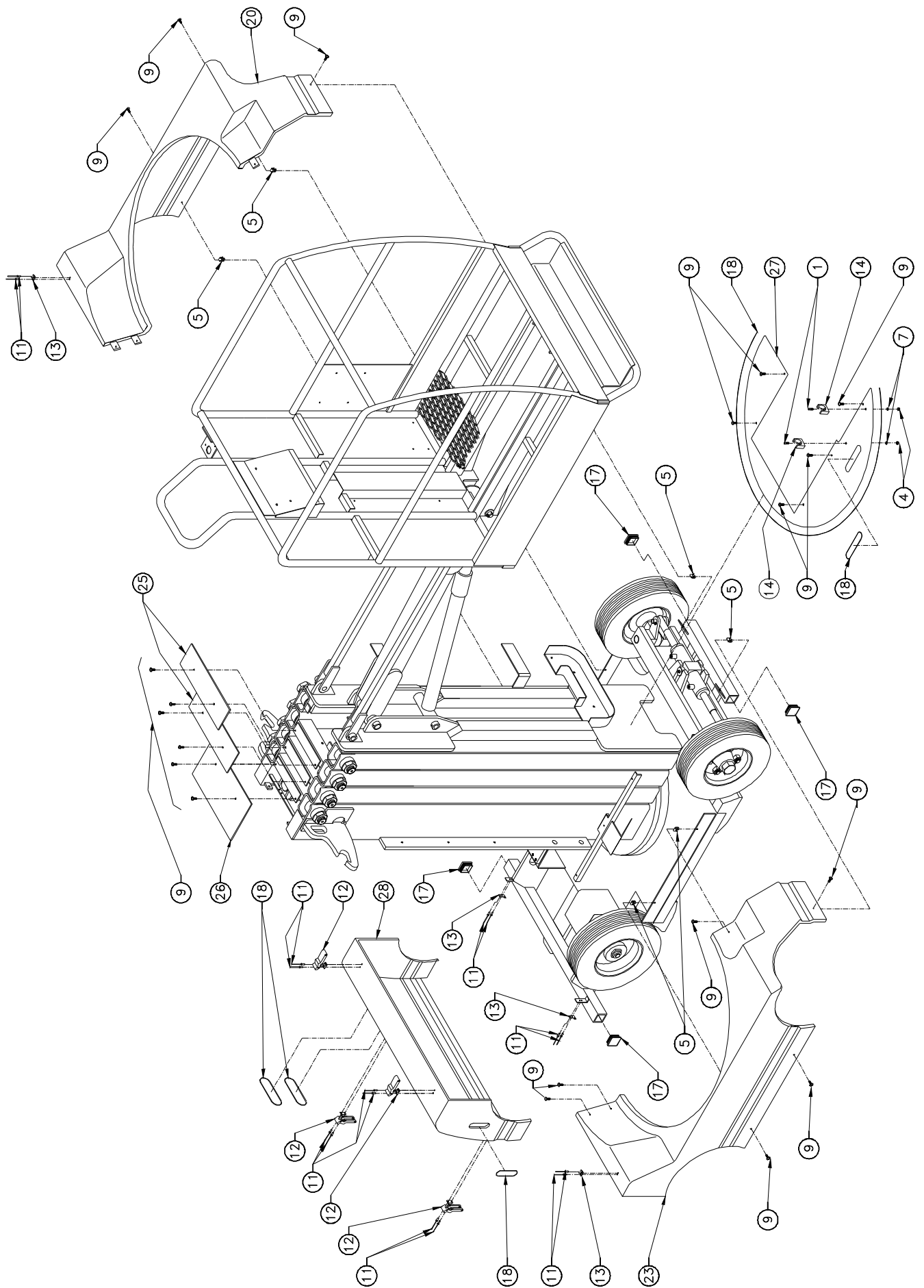

COVERS INSTALL INSTALLATION CAPOTS

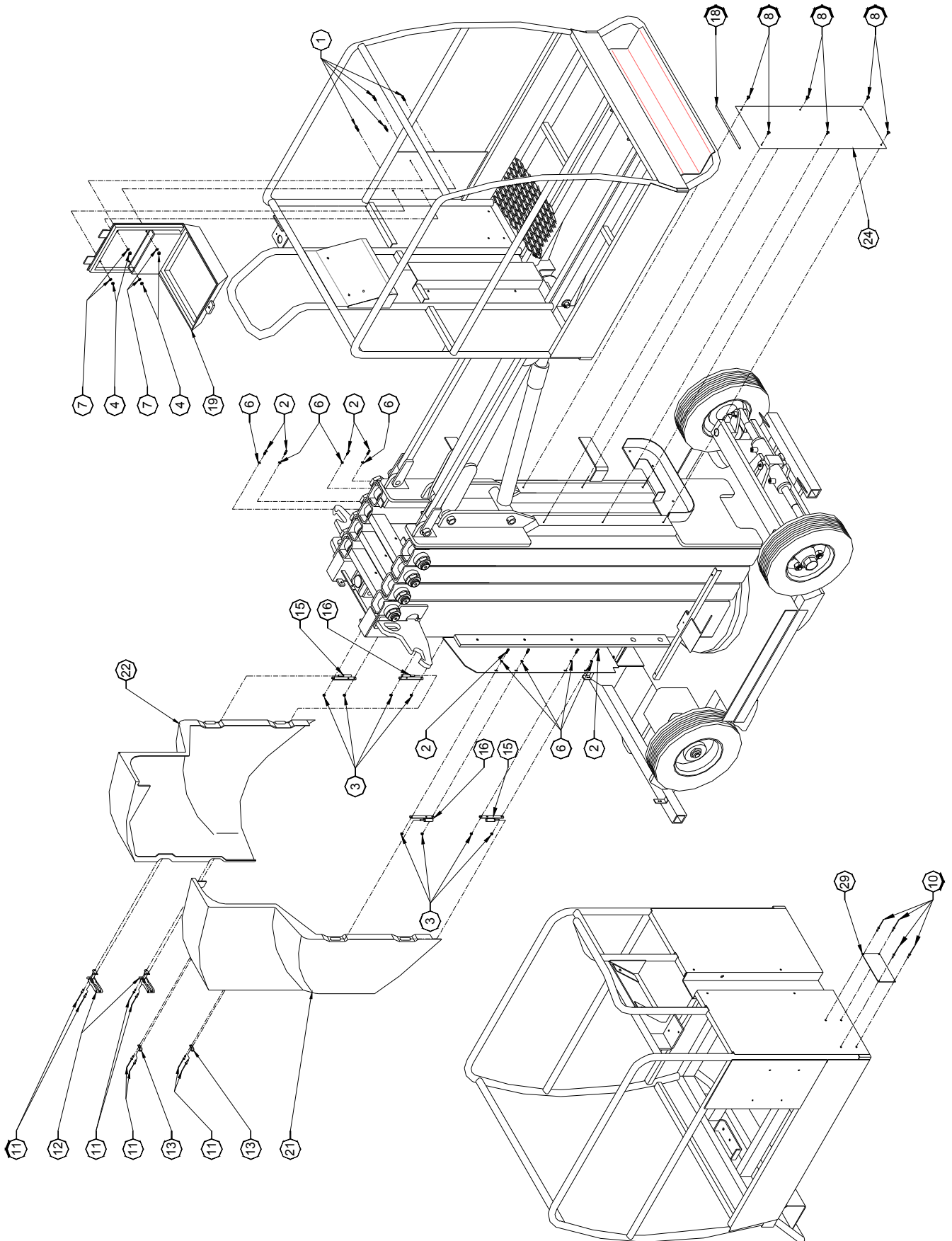

DATE : 25/08/99

COVERS INSTAL

MONTAGE N°/

ASSY NO : SP0241 REV : A

INSTALLATION CAPOTS

1/1

DET NO.	REF./PART NUMBER	VOIR/ SEE VIEW	DESCRIPTION		R E V	Qté/ Qty Req.
1	000005		M06x20 8.8 SOCKET HEAD MACH SCREW	VIS CHC M06x20 8.8 BI FT		6
2	000067		M05x12 8.8 SOCKET HEAD MACH SCREW	VIS CHC M05x12 8.8 BI FT		8
3	110002		M05 GR. 8.8 LOCK NUT	ECROU FREIN M5 8.8 BI		8
4	110003		M06 GR. 8.8 LOCK NUT	ECROU FREIN M6 8.8 BI		6
5	110027		M06 CAGE HEX NUT	ECROU CAGE M06		6
6	120002		M05 WASHER	RONDELLE M05 BI		8
7	120009		dD 06x14 LOCK WASHER	RONDELLE CONTACT dD 06x14 BI		6
8	130007		Ø4.8x13 LG SHEET METAL SCREW	VIS AUTOTARAUDEUSE Ø4,8-13		6
9	130021		M06x20 8.8 ROUND HEAD MACH SCREW	VIS BOMBEE ULF M06x20 8.8 BI FT		20
10	180002		Ø4x10 POP RIVET	RIVET POP Ø4x10		4
11	180005		Ø4x16 POP RIVET	RIVET POP Ø4x16		24
12	190018		C 7-10 RUBBER LATCH	GRENOUILLE C 7-10		6
13	190019		C 7-10 LATCH LOCKING TAB	RECEPTACLE C 7-10		6
14	190027		Ø22 CLIP	CLIP Ø22		2
15	190033		MALE HINGE	PAUMELLE MALE		2
16	190035		MALE HINGE	PAUMELLE MALE		2
17	400004		SHOCK ABSORBER CAP	BOUCHON PARE CHOC		4
18	400032		EDGE GUARD (quantity indicated in meter)	PROFIL A ARMATURE (quantité en mètre)		5
19	7348000653		MANUAL BOX	BOITE PORTE DOCUMENTS		1
20	SD0053		RIGHT SIDE COVER	COQUE DROITE		1
21	SD0313		LEFT DOOR	PORTE GAUCHE		1
22	SD0314		RIGHT DOOR	PORTE DROITE		1
23	ST0129		LEFT SIDE COVER	COQUE GAUCHE		1
24	ST0462		HOSE GUARD COVER / MAST 5	TOLE GOULOTTE MAT 5	A	1
25	ST1004		MAST TOP COVER	COUVRE MAT		2
26	ST1005		MAST TOP COVER	COUVRE MAT		1
27	ST1287		TOP COVER	TOLE COUVRE JOINT		1
28	ST1391		FRONT COVER	COQUE AVANT		1
29		APPENDIX G	PLAQUE CONSTRUCTEUR	MANUFACTURER'S NAME PLATE		1

**SPARE PARTS
PIECES DETACHEES**

SECTION 2.

**COUNTERWEIGHT INSTALL.
INSTALLATION CONTREPOIDS.**



COUNTERWEIGHT INSTALL INSTALLATION CONTREPOIDS

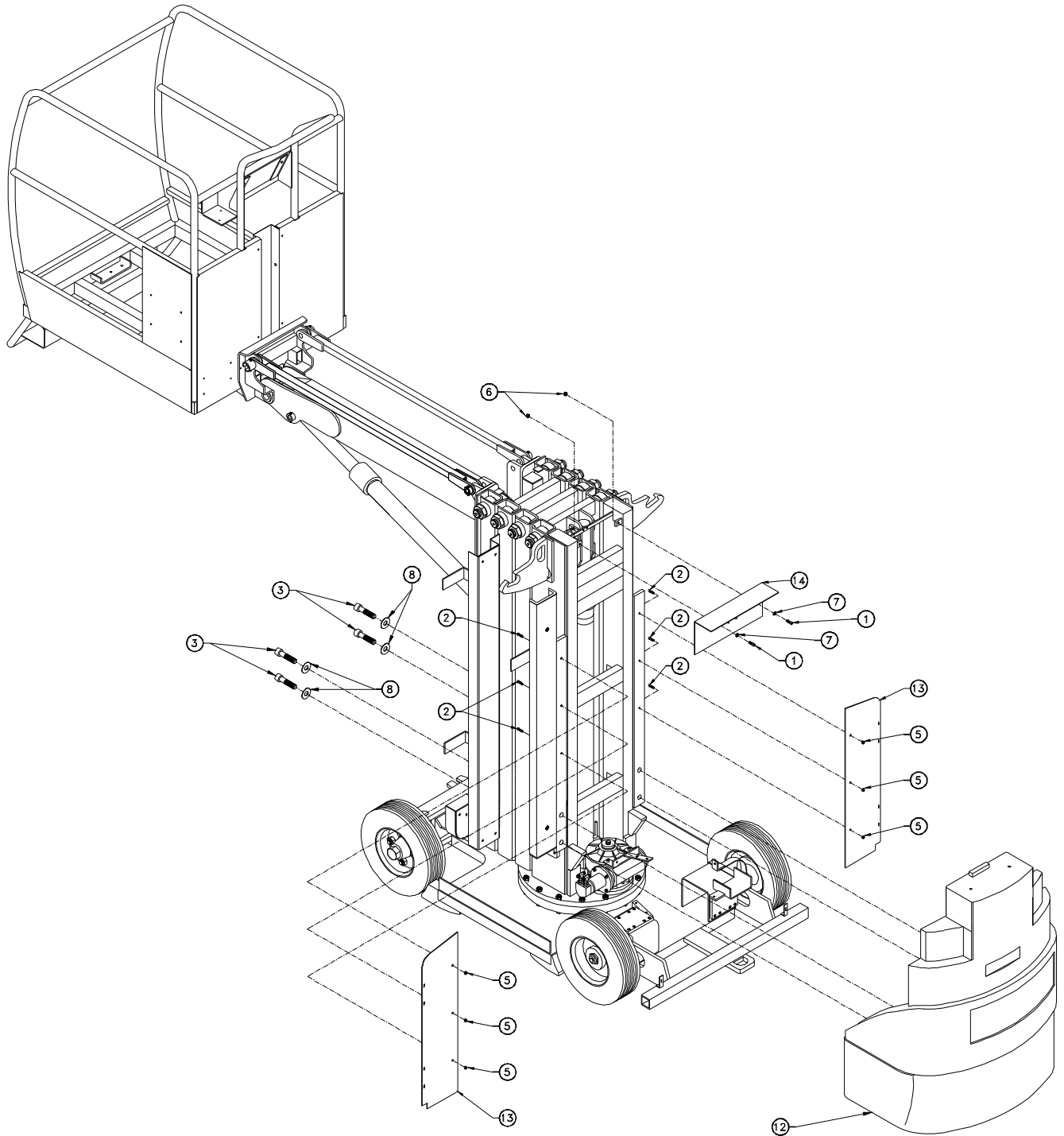

SPARE PARTS
PIECES DETACHEES

SECTION 3.

ELECTRICAL INSTALL.
INSTALLATION ELECTRIQUE.



ELECTRICAL INSTALL INSTALLATION ELECTRIQUE

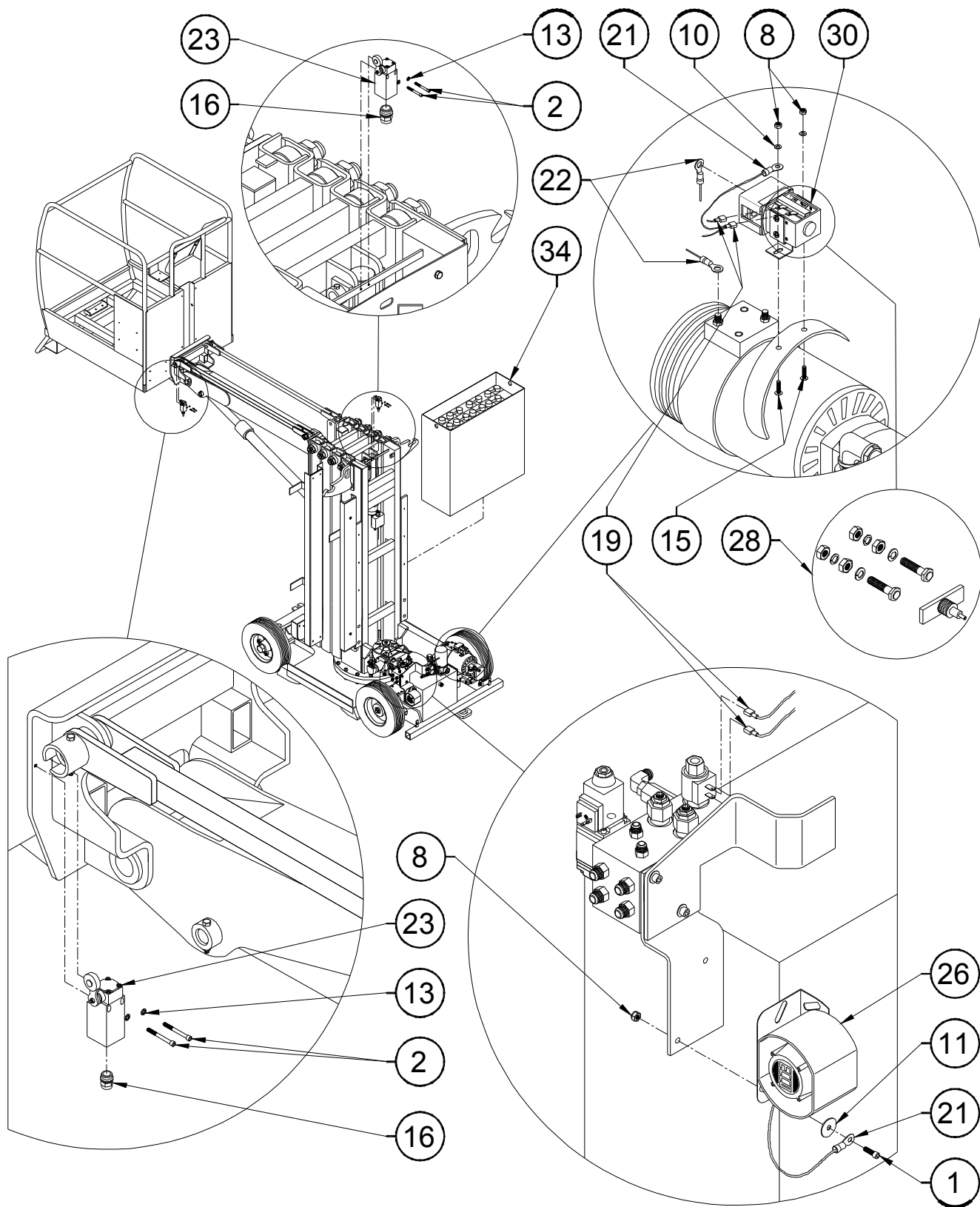

ELECTRICAL INSTALL INSTALLATION ELECTRIQUE

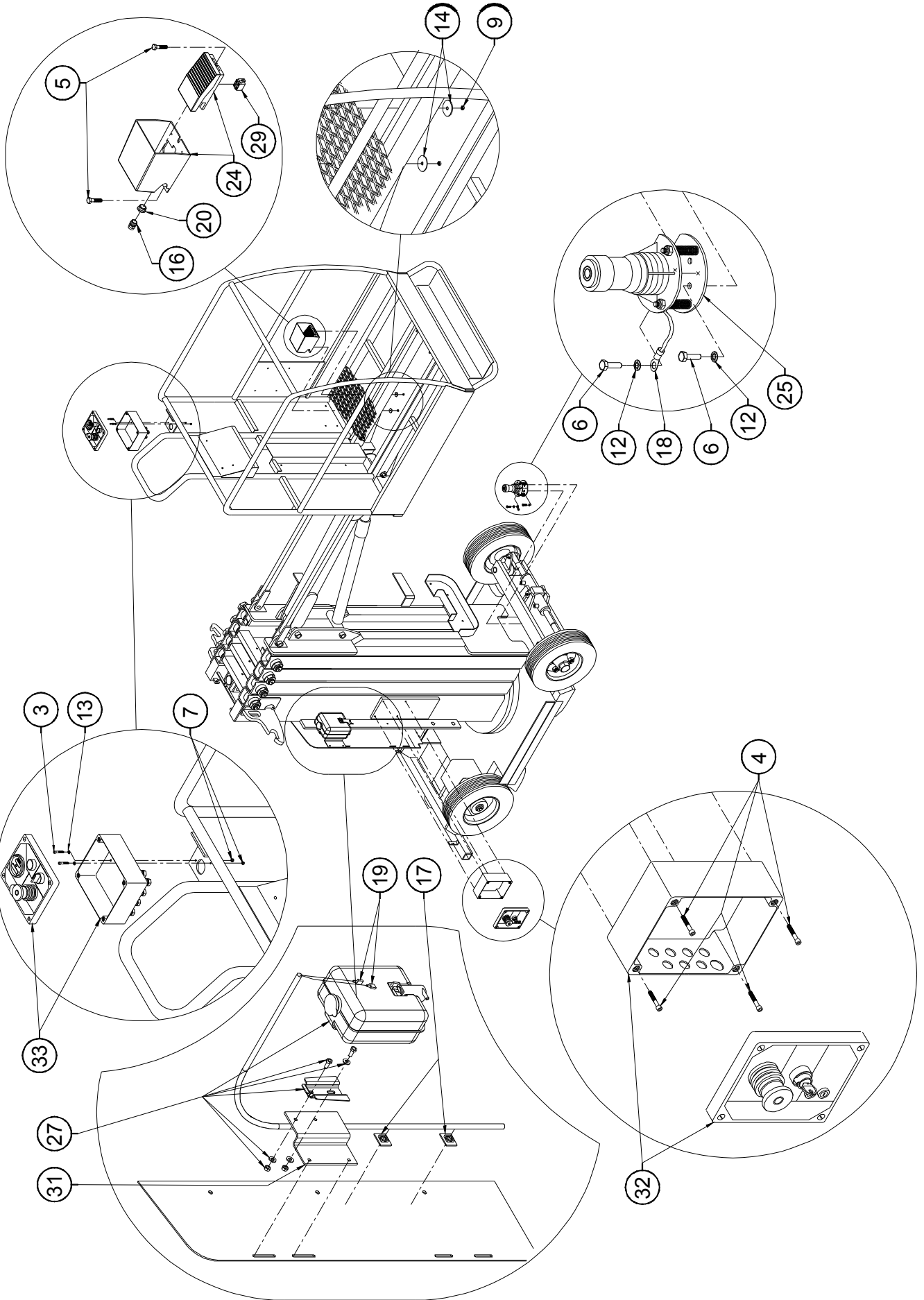

DATE : 07/03/08

ELECTRICAL INSTALL

MONTAGE N°/

ASSY NO : SP0228 REV : D

INSTALLATION ELECTRIQUE

1/1

DET NO.	REF./PART NUMBER	VOIR/ SEE VIEW	DESCRIPTION		RE V	Qté/ Qty Req.
1	000003		M05x16 8.8 SOCKET HEAD MACH SCREW	VIS CHC M05x16 8.8 BI FT		1
2	000004		M04x35 8.8 SOCK. HEAD MACH. SCREW	VIS CHC M04x35 8.8 BI FT		4
3	000020		M04x20 8.8 SOCKET HEAD MACH SCREW	VIS CHC M04x20 8.8 BI FT		2
4	000050		M04x10 8.8 SOCKET HEAD MACH SCREW	VIS CHC M04x10 8.8 BI FT		4
5	100008		M08x30 8.8 HEX HEAD MACHINE SCREW	VIS H M08x30 8.8 BI FT		2
6	100027		M06x12 8.8 HEX HEAD MACHINE SCREW	VIS H M06x12 8.8 BI FT		2
7	110001		M04 GR. 8.8 LOCK NUT	ECROU FREIN M4 8.8 BI		2
8	110002		M05 GR. 8.8 LOCK NUT	ECROU FREIN M5 8.8 BI		3
9	110004		M08 GR. 8.8 LOCK NUT	ECROU FREIN M8 8.8 BI		2
10	120002		M05 WASHER	RONDELLE M05 BI		2
11	120004		dD 06x25 WASHER	RONDELLE dD 06x25x1.2 BI		1
12	120009		dD 06x14 LOCK WASHER	RONDELLE CONTACT dD 06x14 BI		2
13	120024		M04 LOCK WASHER	RONDELLE CONTACT M04 BI		6
14	120026		dD 08x40 WASHER	RONDELLE dD 08x40 BI		2
15	130010		M05x16 8.8 CROSS RECESSED PAN HEAD	VIS POELIER M05x16 8.8 BI FT		2
16	210019		GLAND N°13	PRESSE ETOUPE N°13		3
17	220008		ADHESIVE BASE	EMBASE ADHESIVE		2
18	250010		M08 EYELET TERMINAL 4-6mm ²	COSSE A ŒIL ISOLEE M8 - 4-6mm ²		1
19	250027		BLUE RECEPTACLE TER. 6.3 - 1.5-2.5mm ²	COSSE FEM. 6.3 BLEUE 6.3 - 1.5-2.5mm ²		6
20	250047		16/13 REDUCTION	REDUCTION 16/13		1
21	250082		M05 EYELET TERMINAL 0.25-1mm ²	COSSE A ŒIL ISOLEE M5 - 0.25-1mm ²		2
22	250084		M08 EYELET TERMINAL 0.25-1mm ²	COSSE A ŒIL ISOLEE M8 - 0.25-1mm ²		2
23	260030		2NC SWITCH	CAPTEUR 2NF		2
24	260103		FOOT SWITCH	PEDALE		1
25	260270		2° TILT SENSOR	DETECTEUR DE DEVERS 2°		1
26	260275		ACCOUSTIC MOTION ALARM	ALARME DE MOUVEMENT SONORE		1
27	400058		DISTILLED WATER CAN KIT	KIT BIDON D'EAU DISTILLEE		1
28	910002		CONTACT KIT (included in SE1003)	KIT DE CONTACT (inclus dans SE1003)		1
29	910038		FOOT SW. CONTACT (included in 260103)	CONTACT PEDALE (inclus dans 260103)		1
30	SE1003		POWER RELAY	RELAIS DE PUISSANCE		1
31	ST1978		CAN SUPPORT	SUPPORT BIDON		1
32		SE0803	LOWER CONTROL BOX ASSEMBLY	ASSEMBLAGE BOITIER BAS		1
33		SE0804	UPPER CONTROL BOX ASSEMBLY	ASSEMBLAGE BOITIER HAUT		1
34		APPENDIX F	BATTERY	BATTERIE		1

POWER CIRCUIT CIRCUIT DE PUISSANCE

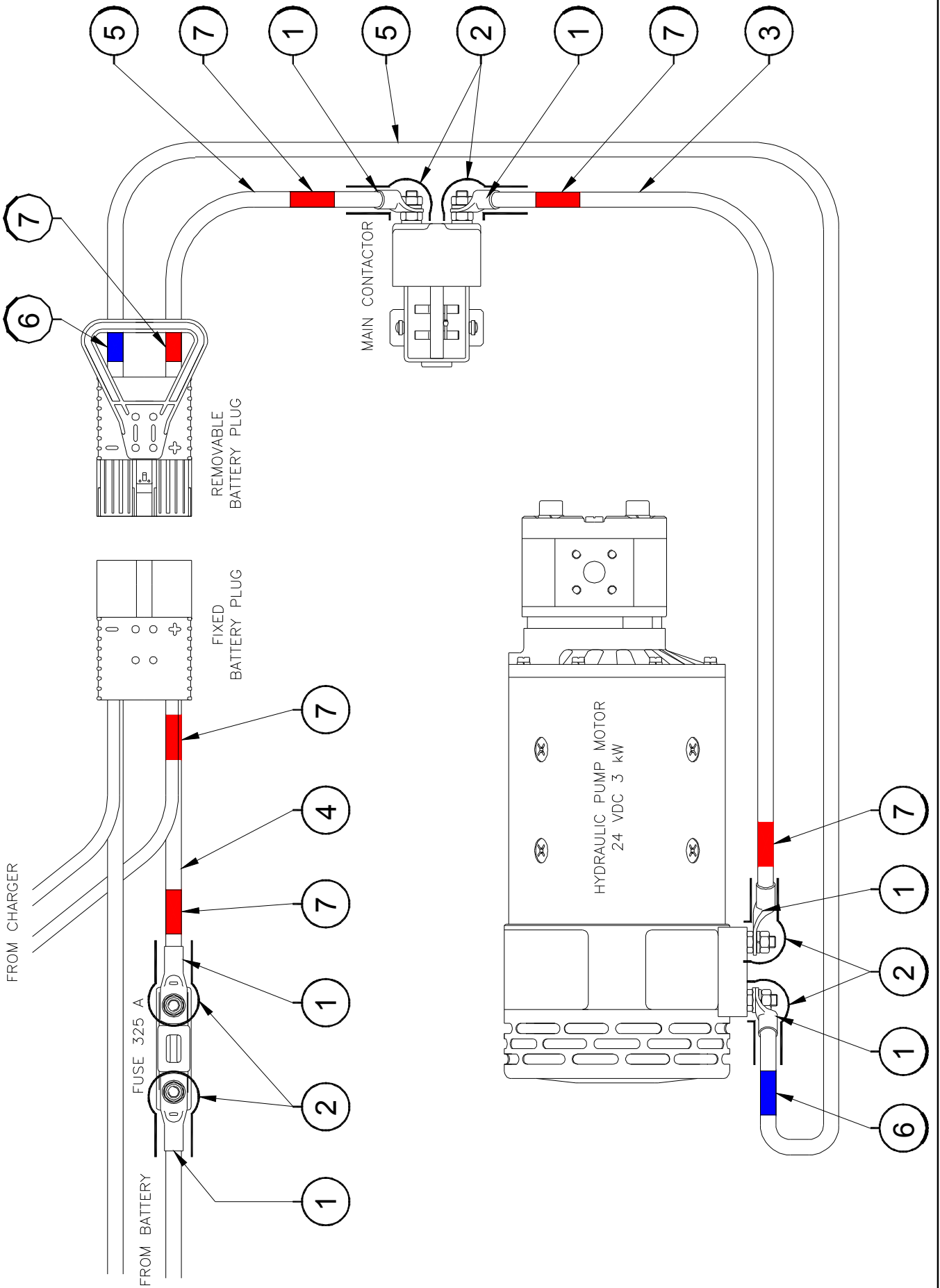

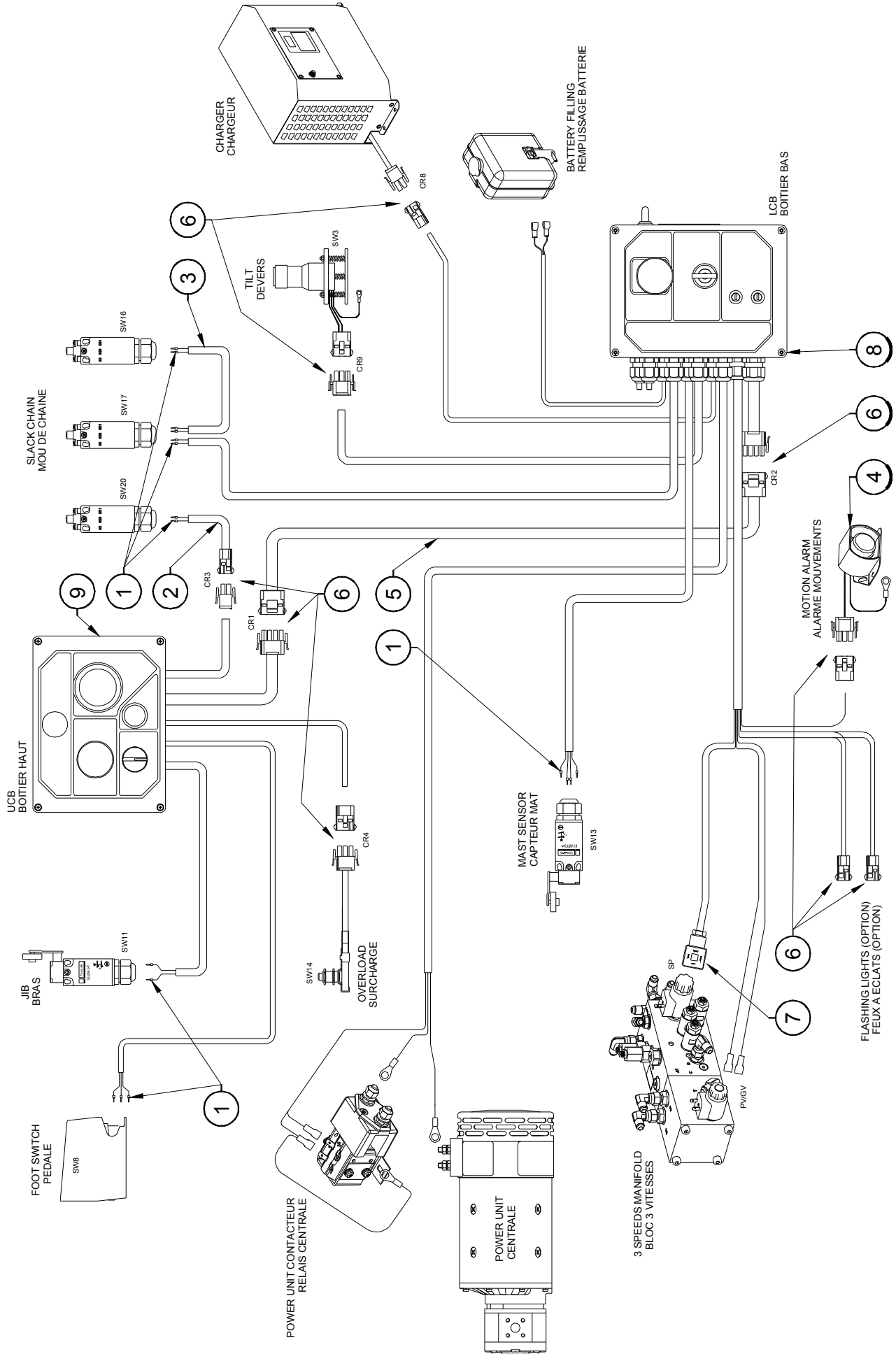

CONTROL CIRCUIT CIRCUIT DE COMMANDE

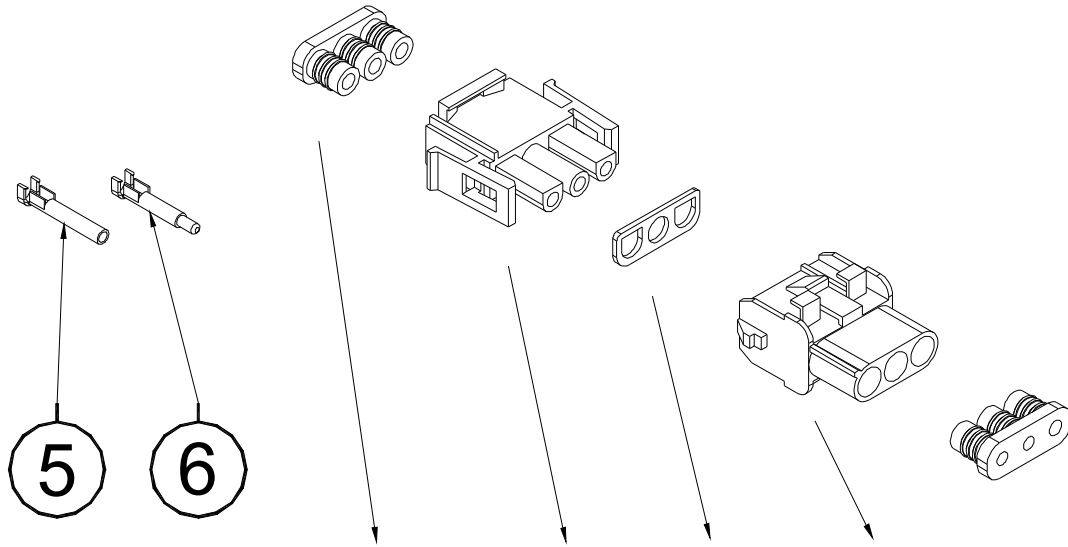

MATE-N-LOK CONNECTORS CONNECTEURS MATE-N-LOK

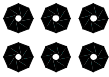
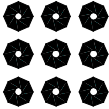
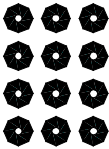

	(26)	(23)	(25)	(24)
	(10)	(7)	(9)	(8)
	(14)	(11)	(13)	(12)
	(18)	(15)	(17)	(16)
	(4)	(1)	(3)	(2)
	(22)	(19)	(21)	(20)

ISSUE DATE : 28/04/03

MATE-N-LOK CONNECTORS

ISSUE REL :

ASSEMBLY N° : RM0090 REV :
 N° ENSEMBLE :

CONNECTEURS MATE-N-LOK

1/1

DET REP	PART NUMBER REF.	SEE VIEW VOIR VUE	DESCRIPTION		R E V	QTY QTE
1	210029		9 POSITIONS PLUG HOUSING "MNL"	CONNECTEUR MALE 9 COSSES "MNL"		
2	210030		9 POSITIONS CAP HOUSING "MNL"	CONNECTEUR FEMELLE 9 COSSES "MNL"		
3	210031		9 POSITIONS INTERFACE SEAL	JOINT INTERFACE CONNECTEUR 9 CTS		
4	210032		9 POSITIONS WIRE SEAL	JOINT ARRIERE CONNECTEUR 9 CTS		
5	210033		SOCKET CONTACT "MATE-N-LOK"	CONTACT FEMELLE "MATE-N-LOK"		
6	210034		PIN CONTACT "MATE-N-LOK"	CONTACT MALE "MATE-N-LOK"		
7	250140		3 POSITIONS "MNL" PLUG HOUSING	CONNECTEUR MALE 3 CONTACTS "MNL"		
8	250141		3 POSITIONS "MNL" CAP HOUSING	CONNECTEUR FEMELLE 3 CTS "MNL"		
9	250143		3 POSITIONS INTERFACE SEAL	JOINT INTERFACE CONNECTEUR 3 CTS		
10	250144		3 POSITIONS WIRE SEAL	JOINT ARRIERE CONNECTEUR 3 CTS		
11	250145		4 POSITIONS "MNL" PLUG HOUSING	CONNECTEUR MALE 4 CONTACTS "MNL"		
12	250146		4 POSITIONS "MNL" CAP HOUSING	CONNECTEUR FEMELLE 4 CTS "MNL"		
13	250148		4 POSITIONS INTERFACE SEAL	JOINT INTERFACE CONNECTEUR 4 CTS		
14	250149		4 POSITIONS WIRE SEAL	JOINT ARRIERE CONNECTEUR 4 CTS		
15	250150		6 POSITIONS "MNL" PLUG HOUSING	CONNECTEUR MALE 6 CONTACTS "MNL"		
16	250151		6 POSITIONS "MNL" CAP HOUSING	CONNECTEUR FEMELLE 6 CTS "MNL"		
17	250153		6 POSITIONS INTERFACE SEAL	JOINT INTERFACE CONNECTEUR 6 CTS		
18	250154		6 POSITIONS WIRE SEAL	JOINT ARRIERE CONNECTEUR 6 CTS		
19	250155		12 POSITIONS "MNL" PLUG HOUSING	CONNECTEUR MALE 12 CONTACTS "MNL"		
20	250156		12 POSITIONS "MNL" CAP HOUSING	CONNECTEUR FEMELLE 12 CTS "MNL"		
21	250158		12 POSITIONS INTERFACE SEAL	JOINT INTERFACE CONNECTEUR 12 CTS		
22	250159		12 POSITIONS WIRE SEAL	JOINT ARRIERE CONNECTEUR 12 CTS		
23	250193		2 POSITIONS "MNL" PLUG HOUSING	CONNECTEUR MALE 2 CONTACTS "MNL"		
24	250194		2 POSITIONS "MNL" CAP HOUSING	CONNECTEUR FEMELLE 2 CTS "MNL"		
25	250195		2 POSITIONS INTERFACE SEAL	JOINT INTERFACE CONNECTEUR 2 CTS		
26	250196		2 POSITIONS WIRE SEAL	JOINT ARRIERE CONNECTEUR 2 CTS		

CONNECTORS ON HARNESS ASSEMBLY CONNECTEURS SUR FAISCEAUX

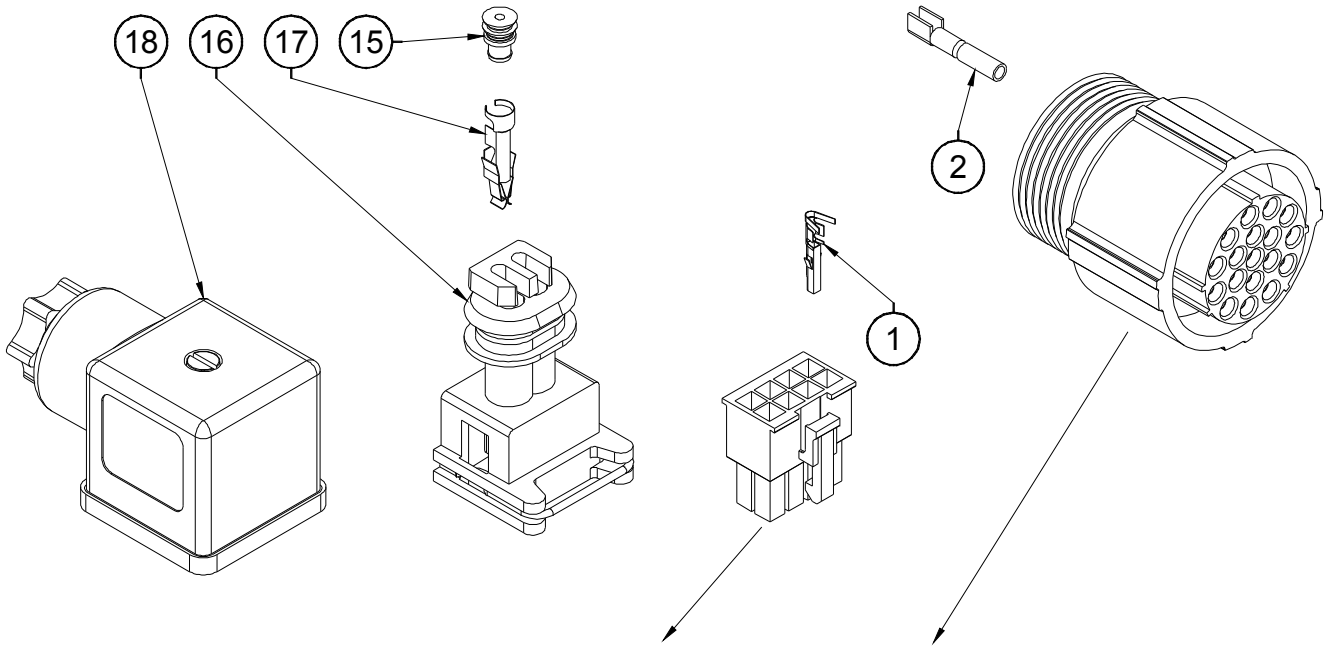

Number of pins Nombre de contacts	PART NUMBER / REP		GLAND / PE	
	MOLEX	FCI		
2	(3)			
4	(4)			
6	(5)			
8	(6)		180°	90°
9		(12)	(22)	
10	(7)			
12	(8)			
14	(9)			
16	(10)			
18		(13)	(21)	(23)
24	(11)			
26		(14)	(20)	(19)

ISSUE DATE : 12/05/03

**CONNECTORS ON HARNESS
ASSEMBLY**

ISSUE REL :

ASSEMBLY N° : RM0091 REV :
N° ENSEMBLE :

CONNECTEURS SUR FAISCEAUX

1/1

DET REP	PART NUMBER REF.	SEE VIEW VOIR VUE	DESCRIPTION		R E V	QTY QTE
1	250190		SOCKET CONTACT "MOLEX MINI-FIT"	CONTACT FEMELLE "MOLEX MINI-FIT"		
2	260130		SOCKET CONTACT	CONTACT A SERTIR FEMELLE		
3	250206		2 POS. "MOLEX MINI-FIT" PLUG HOUSING	CONNECTEUR "MOLEX MINI-FIT" 2 CTS		
4	250199		4 POS. "MOLEX MINI-FIT" PLUG HOUSING	CONNECTEUR "MOLEX MINI-FIT" 4 CTS		
5	250200		6 POS. "MOLEX MINI-FIT" PLUG HOUSING	CONNECTEUR "MOLEX MINI-FIT" 6 CTS		
6	250189		8 POS. "MOLEX MINI-FIT" PLUG HOUSING	CONNECTEUR "MOLEX MINI-FIT" 8 CTS		
7	250201		10 POS. "MOLEX MINI-FIT" PLUG HOUSING	CONNECTEUR "MOLEX MINI-FIT" 10 CTS		
8	250202		12 POS. "MOLEX MINI-FIT" PLUG HOUSING	CONNECTEUR "MOLEX MINI-FIT" 12 CTS		
9	250203		14 POS. "MOLEX MINI-FIT" PLUG HOUSING	CONNECTEUR "MOLEX MINI-FIT" 14 CTS		
10	250204		16 POS. "MOLEX MINI-FIT" PLUG HOUSING	CONNECTEUR "MOLEX MINI-FIT" 16 CTS		
11	250205		24 POS. "MOLEX MINI-FIT" PLUG HOUSING	CONNECTEUR "MOLEX MINI-FIT" 24 CTS		
12	260177		9 POSITIONS SOCKET HOUSING	CONNECTEUR 9 CONTACTS		
13	260168		18 POSITIONS SOCKET HOUSING	CONNECTEUR 18 CONTACTS		
14	260128		26 POSITIONS SOCKET HOUSING	CONNECTEUR 26 CONTACTS		
15	260132		WIRE SEAL	JOINT DE CONNECTEUR		
16	260136		AMP TIMER CAP HOUSING	CONNECTEUR AMP TIMER		
17	260137		RECEPTACLE CONTACT	CONTACT		
18	900087		CONNECTOR DIN43650-A	CONNECTEUR DIN43650-A		
19	210020		90° CABLE GLAND N°29	PRESSE ETOUPE COUDE N°29		
20	260129		CABLE GLAND N°29	PRESSE ETOUPE N°29		
21	260169		CABLE GLAND N°21	PRESSE ETOUPE N°21		
22	260170		CABLE GLAND N°16	PRESSE ETOUPE N°16		
23	260221		90° CABLE GLAND N°21	PRESSE ETOUPE COUDE N°21		

LOWER CONTROL BOX ASSEMBLY ASSEMBLAGE BOITIER ELECTRIQUE BAS

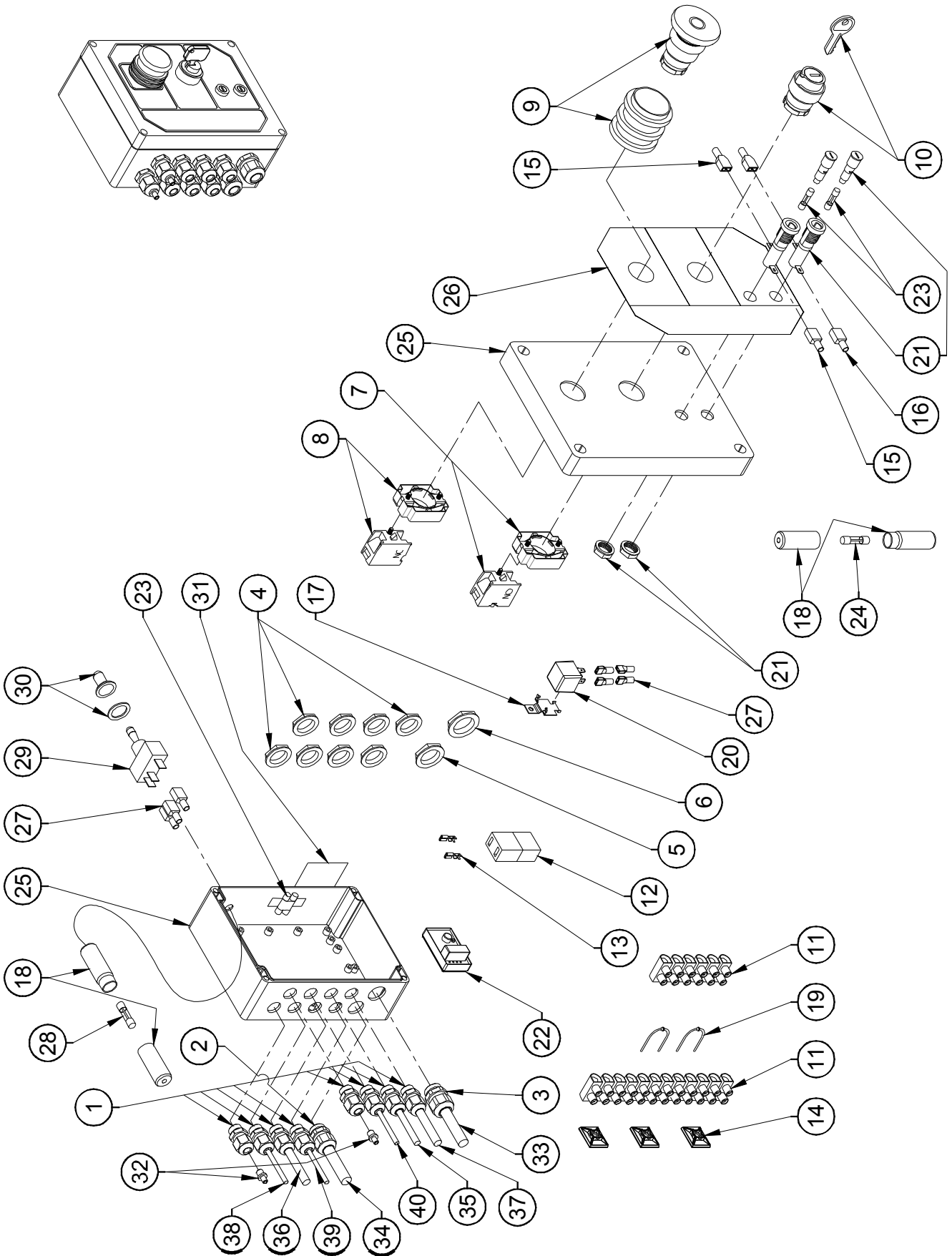

ISSUE DATE : 11/03/08

LOWER CONTROL BOX ASSEMBLY

ISSUE REL :

ASSEMBLY N° : SE0803 REV :
N° ENSEMBLE :**ASSEMBLAGE BOITIER BAS**

1/1

DET REP	PART NUMBER REF.	SEE VIEW VOIR VUE	DESCRIPTION		R E V	QTY QTE
1	210017		GLAND N°9	PRESSE ETOUPE N°9		8
2	210018		GLAND N°11	PRESSE ETOUPE N°11		1
3	210019		GLAND N°13	PRESSE ETOUPE N°13		1
4	210009		GLAND N°9 NUT	ECROU DE PRESSE ETOUPE N°9		8
5	210010		GLAND N°11 NUT	ECROU DE PRESSE ETOUPE N°11		1
6	210011		GLAND N°13 NUT	ECROU DE PRESSE ETOUPE N°13		1
7	240004		CONTACT BLOCK HOLDER NO	EMBASE CONTACT NO		1
8	240013		NC CONTACT BLOCK HOLDER	EMBASE CONTACT NC		1
9	240025		KNOB (EMERGENCY STOP SWITCH)	ARRET D'URGENCE		1
10	240032		2 POSITIONS KEY SELECTOR	SELECTEUR A CLE 2 POSITIONS		1
11	250020		TERMINAL BLOCK	BARRETTE DE CONNEXION		18
12	250174		2 POSITIONS "AMP" PLUG HOUSING	CONNECTEUR "AMP" FEMELLE 2 BROCHES		1
13	250035		RECEPTACLE TERMINAL 6.3mm	COSSE PLATE FEMELLE 6.3mm		2
14	220008		ADHESIVE BASE	EMBASE ADHESIVE		3
15	250060		RECEPTACLE TERMINAL 4.8 - 0.25-1 mm ²	COSSE ISOLEE 4.8 mm 0.25-1 mm ²		3
16	250061		RECEPTACLE TERMINAL 4.8 - 1.5-2.5 mm ²	COSSE ISOLEE 4.8 mm 1.5-2.5 mm ²		1
17	260049		RELAY HOLDER	SUPPORT RELAIS		1
18	260007		FUSE HOLDER	PORTE FUSIBLE		2
19	260010		DIODE	DIODE		2
20	260019		1RT 24V RELAY	RELAIS 24 V 1RT		1
21	260224		FUSE HOLDER	PORTE FUSIBLE		2
22	290058		POWER TIMER	TEMPORISATION MACHINE		1
23	260074		5A QUICK ACTING FUSE	FUSIBLE RAPIDE 5A		4
24	260104		500mA QUICK ACTING FUSE	FUSIBLE RAPIDE 500mA		2
25	SD0638		DRILLED ELECTRICAL BOX	BOITIER ELECTRIQUE PERCE		1
26	AU1879		LOWER CONTROL BOX DECAL	AUTOCOLLANT BOITIER BAS		1
27	250027		BLUE RECEPTACLE TER. 6.3 - 1.5-2.5mm ²	COSSE FEM. 6.3 BLEUE 6.3 - 1.5-2.5mm ²		7
28	260006		5x20 3.15A FUSE	FUSIBLE 5x20 3.15A		2
29	260133		SINGLE POLE TOGGLE SWITCH	INVERSEUR UNIPOLAIRE		1
30	260135		TOGGLE SWITCH COVER	PROTECTION D'INTERRUPTEUR		1
31	AU1124		WATER CAN DECAL	AUTOCOLLANT BIDON D'EAU		1
32	210060		N°9 GLAND CAP	BOUCHON DE PRESSE ETOUPE N°9		2
33	270008		CABLE 12x1mm ² (quantity indicated in meter)	CABLE 12x1mm ² (qté indiquée en mètre)		1.5
34	270008		CABLE 12x1mm ² (quantity indicated in meter)	CABLE 12x1mm ² (qté indiquée en mètre)		4.32
35	270022		CABLE 3x1mm ² (quantity indicated in meter)	CABLE 3x1mm ² (qté indiquée en mètre)		4.3
36	270029		CABLE 5x1mm ² (quantity indicated in meter)	CABLE 5x1mm ² (qté indiquée en mètre)		3.05
37	270029		CABLE 5x1mm ² (quantity indicated in meter)	CABLE 5x1mm ² (qté indiquée en mètre)		4.12
38	270031		CABLE 2x1mm ² (quantity indicated in meter)	CABLE 2x1mm ² (qté indiquée en mètre)		0.85
39	270031		CABLE 2x1mm ² (quantity indicated in meter)	CABLE 2x1mm ² (qté indiquée en mètre)		2.45
40	270031		CABLE 2x1mm ² (quantity indicated in meter)	CABLE 2x1mm ² (qté indiquée en mètre)		2.85

UPPER CONTROL BOX ASSEMBLY ASSEMBLAGE BOITIER ELECTRIQUE HAUT

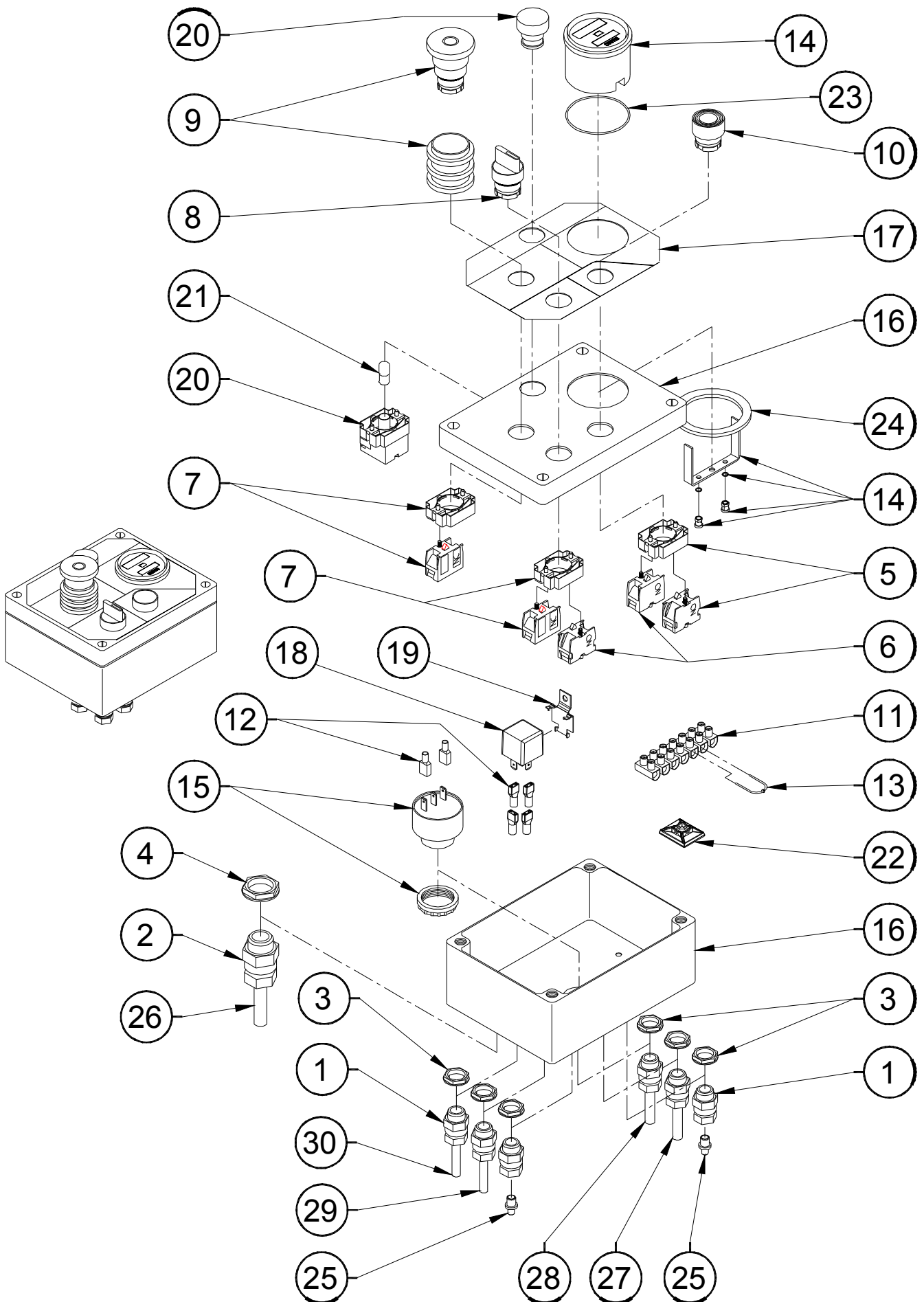

DATE : 10/03/08

UPPER CONTROL BOX ASSEMBLY

MONTAGE N°/

ASSY NO : SE0804 REV :

ASSEMBLAGE BOITIER HAUT

1/1

DET NO.	REF./PART NUMBER	VOIR/SEE VIEW	DESCRIPTION		REVIEW	Qté/Qty Req.
1	210017		GLAND N°9	PRESSE ETOUPE N°9		6
2	210019		GLAND N°13	PRESSE ETOUPE N°13		1
3	210009		GLAND N°9 NUT	ECROU DE PRESSE ETOUPE N°9		6
4	210011		GLAND N°13 NUT	ECROU DE PRESSE ETOUPE N°13		1
5	240004		CONTACT BLOCK HOLDER NO	EMBASE CONTACT NO		1
6	240006		NO CONTACT BLOCK	CONTACT NO		2
7	240013		NC CONTACT BLOCK HOLDER	EMBASE CONTACT NC		2
8	240014		3 POSITIONS SELECTOR	SELECTEUR 3 POSITIONS		1
9	240025		KNOB (EMERGENCY STOP SWITCH)	ARRET D'URGENCE		1
10	240026		PUSH BUTTON	BOUTON POUSSOIR		1
11	250020		TERMINAL BLOCK	BARRETTE DE CONNEXION		7
12	250027		BLUE RECEPTACLE TER. 6.3 - 1.5-2.5mm	COSSE FEM. 6.3 BLEUE 6.3 - 1.5-2.5mm ²		6
13	260010		DIODE	DIODE		1
14	260142		24V HOURMETRE BATTERY INDICATOR	INDICATEUR DE DECHARGE HORAMETRE		1
15	260045		BUZZER 24 V	BUZZER 24 V		1
16	SD0640		DRILLED ELECTRICAL BOX	BOITIER ELECTRIQUE PERCE		1
17	AU1869		UPPER CONTROL BOX DECAL	AUTOCOLLANT BOITIER HAUT		1
18	260019		1RT 24V RELAY	RELAIS 24 V 1RT		1
19	260049		RELAY HOLDER	SUPPORT RELAIS		1
20	240022		LED	VOYANT		1
21	240024		BULBE 24 V	AMPOULE 24 V		1
22	220008		ADHESIVE BASE	EMBASE ADHESIVE		1
23	260209		CHARGE INDICATOR RING	JOINT INDICATEUR DE DECHARGE		1
24	ST2064		BATTERY INDICATOR REINFORCEMENT	RENFORT INDICATEUR BATTERIE		1
25	210060		N°9 GLAND CAP	BOUCHON DE PRESSE ETOUPE N°9		2
26	270008		CABLE 12x1mm ² (quantity indicated in meter)	CABLE 12x1mm ² (qté indiquée en mètre)		0.5
27	270022		CABLE 3x1mm ² (quantity indicated in meter)	CABLE 3x1mm ² (qté indiquée en mètre)		0.5
28	270022		CABLE 3x1mm ² (quantity indicated in meter)	CABLE 3x1mm ² (qté indiquée en mètre)		2
29	270031		CABLE 2x1mm ² (quantity indicated in meter)	CABLE 2x1mm ² (qté indiquée en mètre)		0.3
30	270031		CABLE 2x1mm ² (quantity indicated in meter)	CABLE 2x1mm ² (qté indiquée en mètre)		1.75

SPARE PARTS
PIECES DETACHEES

SECTION 4.

CHARGER INSTALL.
INSTALLATION CHARGEUR.



CHARGER INSTALL INSTALLATION CHARGEUR

LOW FREQUENCY CHARGER
CHARGEUR BASSE FREQUENCE

HIGHT FREQUENCY CHARGER
CHARGEUR HAUTE FREQUENCE

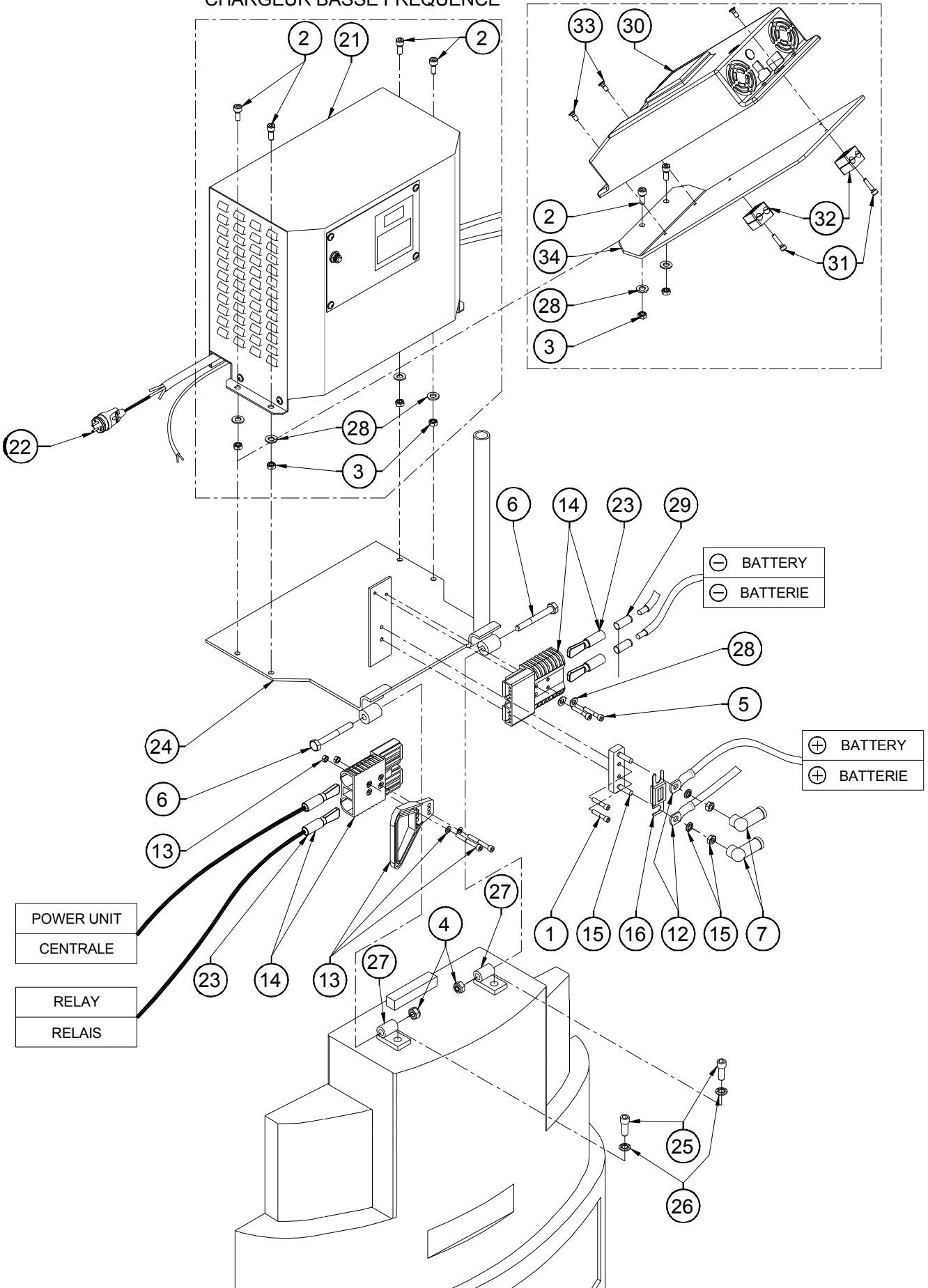

DATE : 10/03/08

CHARGER INSTALL

MONTAGE N°/

ASSY NO : SP0211 REV : E

INSTALLATION CHARGEUR

1/1

DET NO.	REF P/N	VOIR/ SEE VIEW	DESCRIPTION		R E V	Qté/ Qty Req.
1	000005		M06x20 8.8 SOCKET HEAD MACH SCREW	VIS CHC M06x20 8.8 BI FT		2
2	000018		M08x16 8.8 SOCKET HEAD MACH SCREW	VIS CHC M08x16 8.8 BI FT		4
3	110004		M08 GR. 8.8 LOCK NUT	ECROU FREIN M8 8.8 BI		4
4	110005		M10 GR. 8.8 LOCK NUT	ECROU FREIN M10 8.8 BI		2
5	000077		M06x35 8.8 SOCKET HEAD CAPSCREW	VIS CHC M06x35 8.8 BI FP	C	2
6	100091		M10x80 8.8 HEX HEAD CAPSCREW	VIS H M10x80 8.8 BI FP		2
7	250031		TERMINAL CAP	CAPUCHON D'ETANCHEITE		2
8			NOT REQUIRED	NON REQUIS	E	
9			NOT REQUIRED	NON REQUIS	E	
10			NOT REQUIRED	NON REQUIS	E	
11			NOT REQUIRED	NON REQUIS	E	
12	250030		Ø8 EYELET CRIMP TERMINAL 35 mm ²	COSSE A ŒIL Ø 8 - 35 mm ²		2
13	250101		QUICK CONNECTOR HANDLE KIT	POIGNEE POUR PRISE RAPIDE		1
14	250102		QUICK CONNECTOR	CONNECTEUR RAPIDE		2
15	260077		POWER FUSE HOLDER	PORTE FUSIBLE DE PUISSANCE		1
16	260079		325A FUSE	FUSIBLE 325A		1
17			NOT REQUIRED	NON REQUIS	E	
18			NOT REQUIRED	NON REQUIS	E	
19			NOT REQUIRED	NON REQUIS	E	
20			NOT REQUIRED	NON REQUIS	E	
21		APPENDIX F	LOW FREQUENCY CHARGER	CHARGEUR BASSE FREQUENCE		1
22		APPENDIX F	CHARGER CONNECTOR	PRISE CHARGEUR	C	1
23	910031		2 BLADE CONTACTS (included in 250102)	2 COSSES PRISE (inclus dans 250102)		2
24	DL0590		CHARGER SUPPORT	SUPPORT CHARGEUR	C	1
25	100021		M12x25 8.8 HEX HEAD MACHINE SCREW	VIS H M12x25 8.8 BI FT	B	2
26	120015		dD 12x27 LOCK WASHER	RONDELLE CONTACT dD 12x27 BI	B	2
27	DL0421		CHARGER SUPPORT ATTACHMENT	FIXATION SUPPORT CHARGEUR	A	2
28	120009		dD 06x14 LOCK WASHER	RONDELLE CONTACT dD 06x14 BI	D	6
29	250192		REDUCEUR CAP 50 mm ²	EMBOUT REDUCTEUR 50 mm ²	C	2
30		APPENDIX F	HIGHT FREQUENCY CHARGER	CHARGEUR HAUTE FREQUENCE	D	1
31	000008		M06x25 8.8 SOCKET HEAD MACH SCREW	VIS CHC M06x25 8.8 BI FT	D	2
32	400018		PAIR 1/2 SHELL Ø12-12	PAIRE DEMI COQUILLE Ø12-12	D	2
33	130003		M06x16 10.9 COUNTERSUNK HEAD M. S.	VIS FHC M06x16 10.9 BI FT	D	3
34	ST2489		HF CHARGER PLATE	PLATINE CHARGEUR HF	D	1

SPARE PARTS
PIECES DETACHEES

SECTION 5.

**CHANNEL AND POWER BRIDGE INSTALL.
INSTALLATION GOULOTTES ET CHAINES PORTE
CABLES.**



CHANNEL AND POWERBRIDGE INSTALL INSTALLATION GOULOTTES ET CHAINES PORTE CABLES

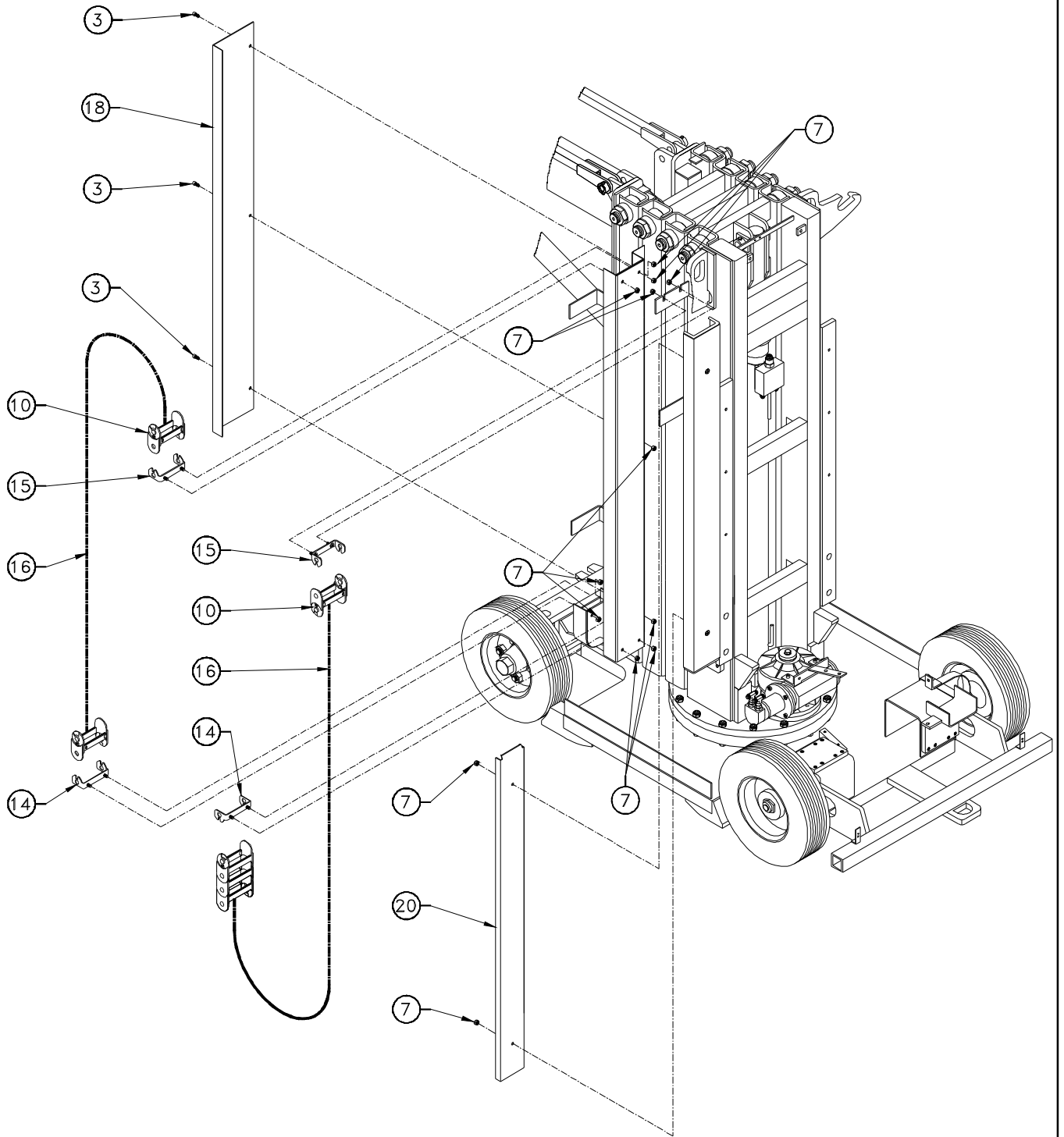

CHANNEL AND POWERBRIDGE INSTALL INSTALLATION GOULOTTES ET CHAINES PORTE CABLES

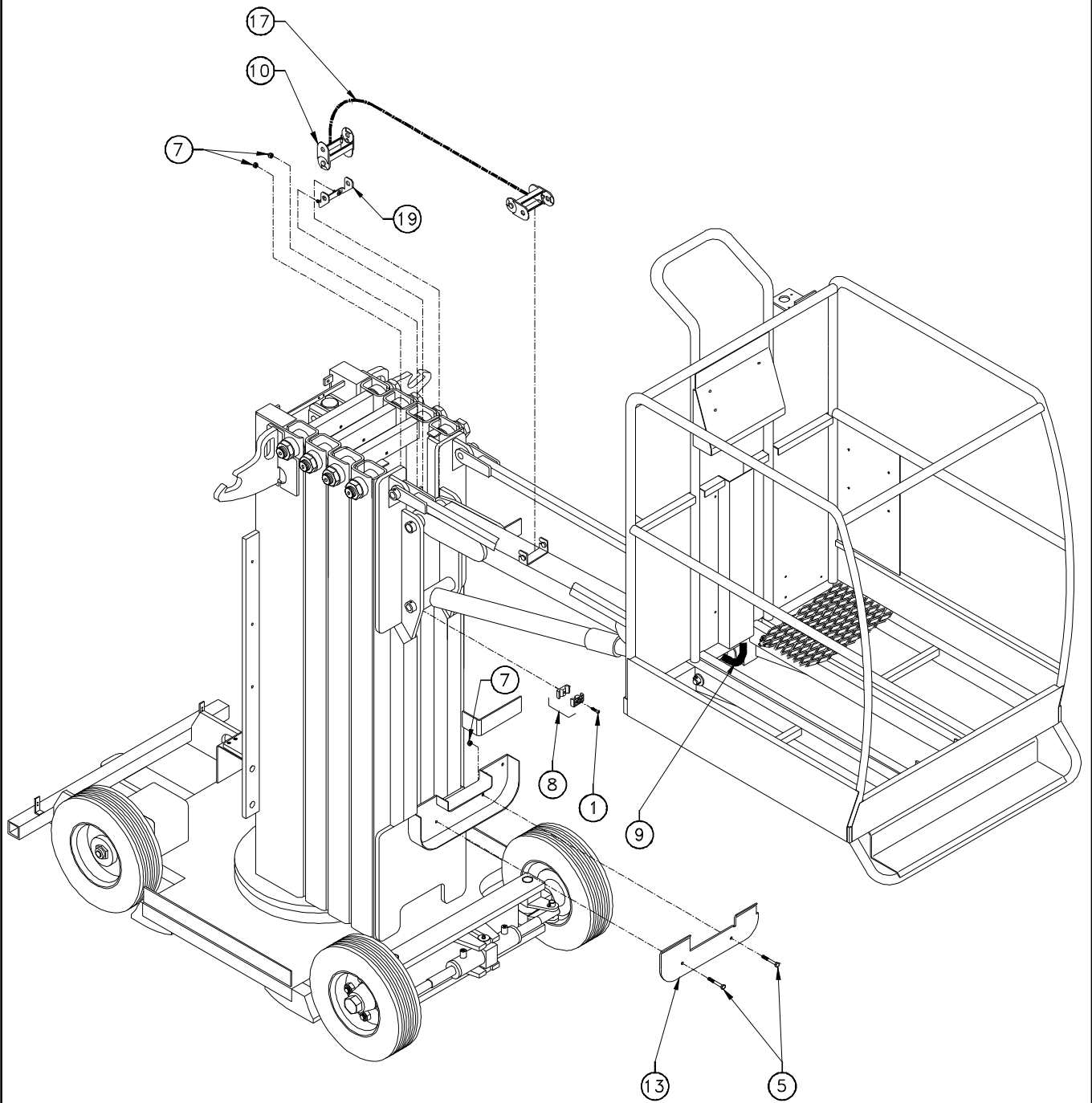

CHANNEL AND POWERBRIDGE INSTALL INSTALLATION GOULOTTES ET CHAINES PORTE CABLES

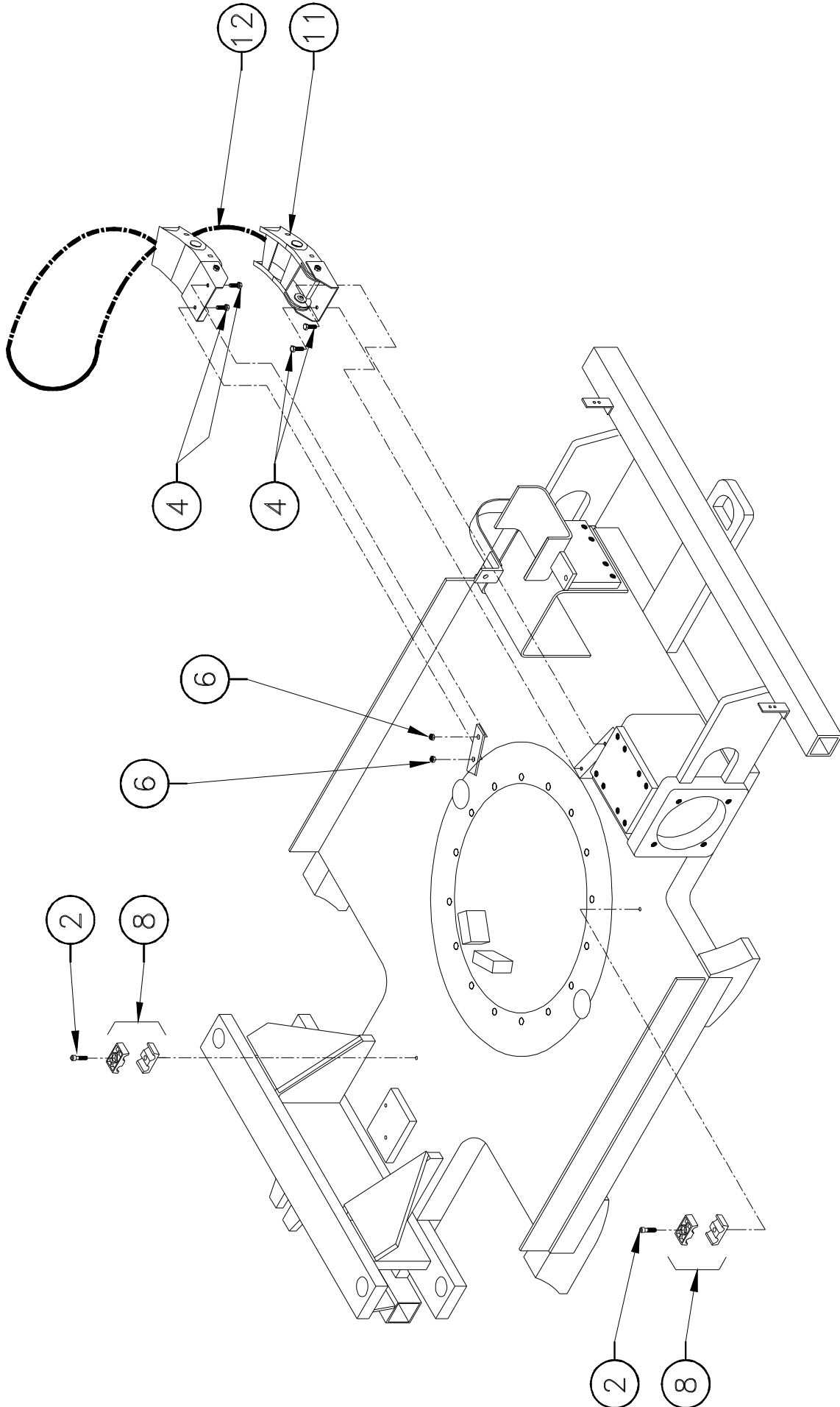

DATE : 12/01/98

**CHANNEL AND POWER BRIDGE
INSTALL**

MONTAGE N°/

ASSY NO : SP0225 REV :

**INSTALLATION CHAINES PORTE
CABLES**

1/1

DET NO.	REF./PART NUMBER	VOIR/ SEE VIEW	DESCRIPTION		R E V	Qté/ Qty Req.
1	000005		M06x20 8.8 SOCKET HEAD MACH SCREW	VIS CHC M06x20 8.8 BI FT		1
2	000008		M06x25 8.8 SOCKET HEAD MACH SCREW	VIS CHC M06x25 8.8 BI FT		2
3	000018		M08x16 8.8 SOCKET HEAD MACH SCREW	VIS CHC M08x16 8.8 BI FT		3
4	100098		M06x16 8.8 HEX HEAD MACHINE SCREW	VIS H M06x16 8.8 BI FT		4
5	100140		M08x60 8.8 HEX HEAD CAPSCREW	VIS H M08x60 8.8 BI FP		2
6	110003		M06 GR. 8.8 LOCK NUT	ECROU FREIN M6 8.8 BI		2
7	110004		M08 GR. 8.8 LOCK NUT	ECROU FREIN M8 8.8 BI		16
8	400018		PAIR 1/2 SHELL D12.7	PAIRE DEMI COQUILLE D12.7		3
9	400021		SHEAT HOSES (quantity indicated in meter)	GAINE FLEXIBLES (quantité en mètres)		1
10	920001		POWER BRIDGE LINK	MAILLON DE CHAINE		x
11	920002		SWING POWER BRIDGE LINK	MAILLON DE CHAINE CIRCULAIRE		x
12	ST0175		SWING POWER BRIDGE	CHAINE PORTE CABLE CIRCULAIRE		1
13	ST0333		HOSE GUARD COVER / MAST 5	TOLE GOULOTTE MAT 5		1
14	ST0339		MOUNTING BRACKET WITH PIN	EQUERRE AVEC AXE		2
15	ST0340		MOUNTING BRACKET WITHOUT PIN	EQUERRE AVEC PERCAGE		2
16	ST0341		POWER BRIDGE	CHAINE PORTE CABLE		2
17	ST0342		JIB POWER BRIDGE	CHAINE PORTE CABLE DU BRAS		1
18	ST0402		HOSE GUARD COVER / MAST 3	TOLE GOULOTTE MAT 3		1
19	ST0439		JIB MOUNTING BRACKET	EQUERRE CHAINE BRAS		1
20	ST1336		HOSE GUARD COVER / MAST 1	TOLE GOULOTTE MAT 1		1

SPARE PARTS
PIECES DETACHEES

SECTION 6.

HYDRAULIC INSTALL.
INSTALLATION HYDRAULIQUE.



HYDRAULIC INSTALL INSTALLATION HYDRAULIQUE

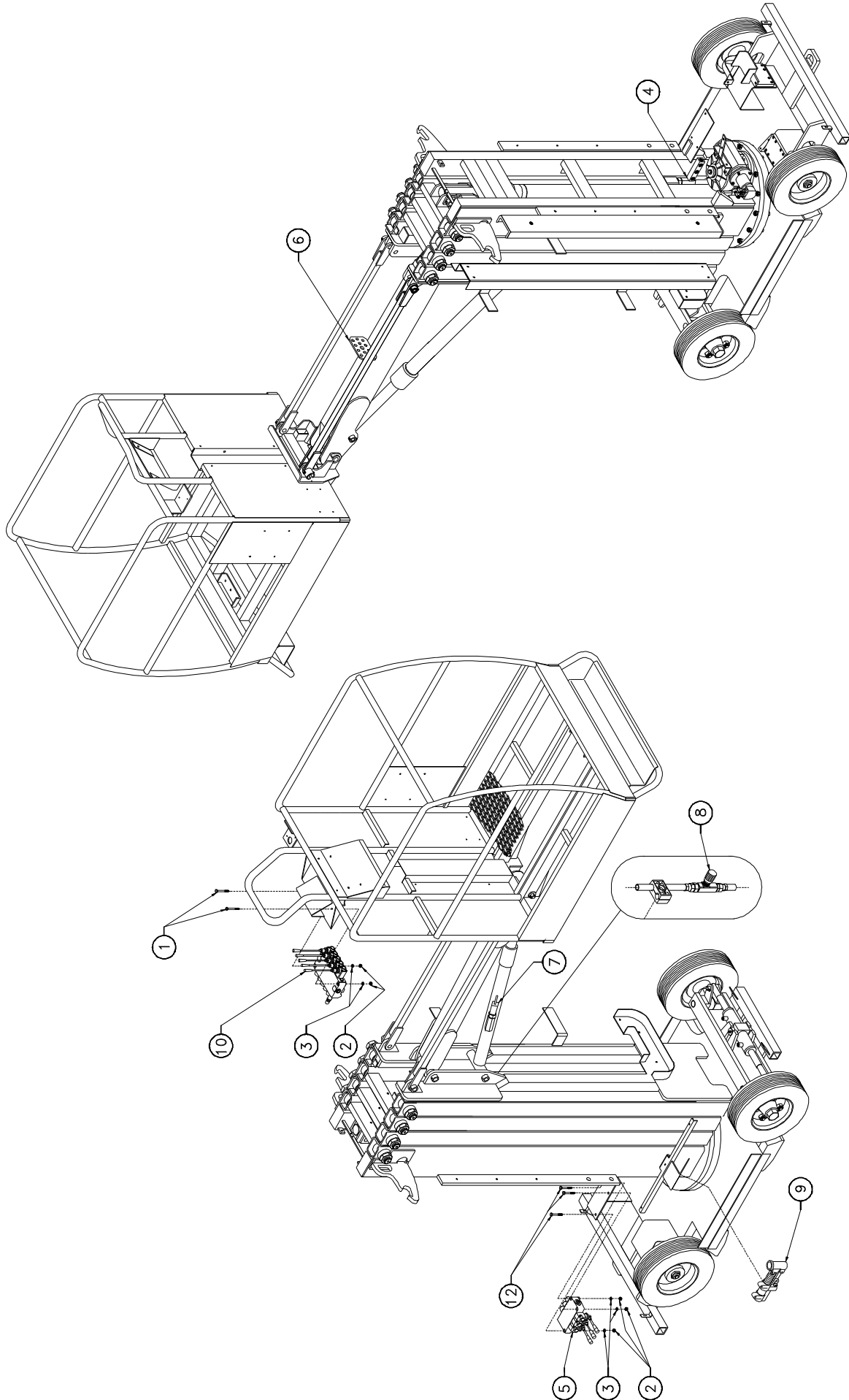

DATE : 15/01/98

HYDRAULIC INSTALL

MONTAGE N°/
ASSY NO : SP0222 REV :

INSTALLATION HYDRAULIQUE

1/1

DET NO.	REF./PART NUMBER	VOIR/ SEE VIEW	DESCRIPTION		R E V	Qté/ Qty Req.
1	100017		M08x70 8.8 HEX HEAD MACHINE SCREW	VIS H M08x70 8.8 BI FT		2
2	110004		M08 GR. 8.8 LOCK NUT	ECROU FREIN M8 8.8 BI		4
3	120010		dD 08x18 LOCK WASHER	RONDELLE CONTACT dD 08x18 BI		4
4		SP0221	MAST CYLINDER ASSEMBLY	ASSEMBLAGE VERIN DE MAT		1
5		SP0236	LOWER VALVE ASSEMBLY	ASSEMBLAGE DISTRIBUTEUR BAS		1
6		SP0237	BULKHEAD ASSEMBLY	ASSEMBLAGE TRAVERSEE DE CLOISON		1
7		SP0238	JIB CYLINDER ASSEMBLY	ASSEMBLAGE VERIN DE BRAS		1
8		SP0239	JIB FLOW CONTROL ASSEMBLY	ASSEMBLAGE ETRANGLEUR BRAS		1
9		SP0240	HAND PUMP ASSEMBLY	ASSEMBLAGE POMPE A MAIN		1
10		APPENDIX C	UPPER VALVE ASSEMBLY	ASSEMBLAGE DISTRIBUTEUR HAUT		1
11			NOT REQUIRED	NON REQUIS		
12	100140		M08x60 8.8 HEX HEAD CAPSCREW	VIS H M08x60 8.8 BI FP		2

MAST CYLINDER ASSEMBLY ASSEMBLAGE VERIN DE MAT

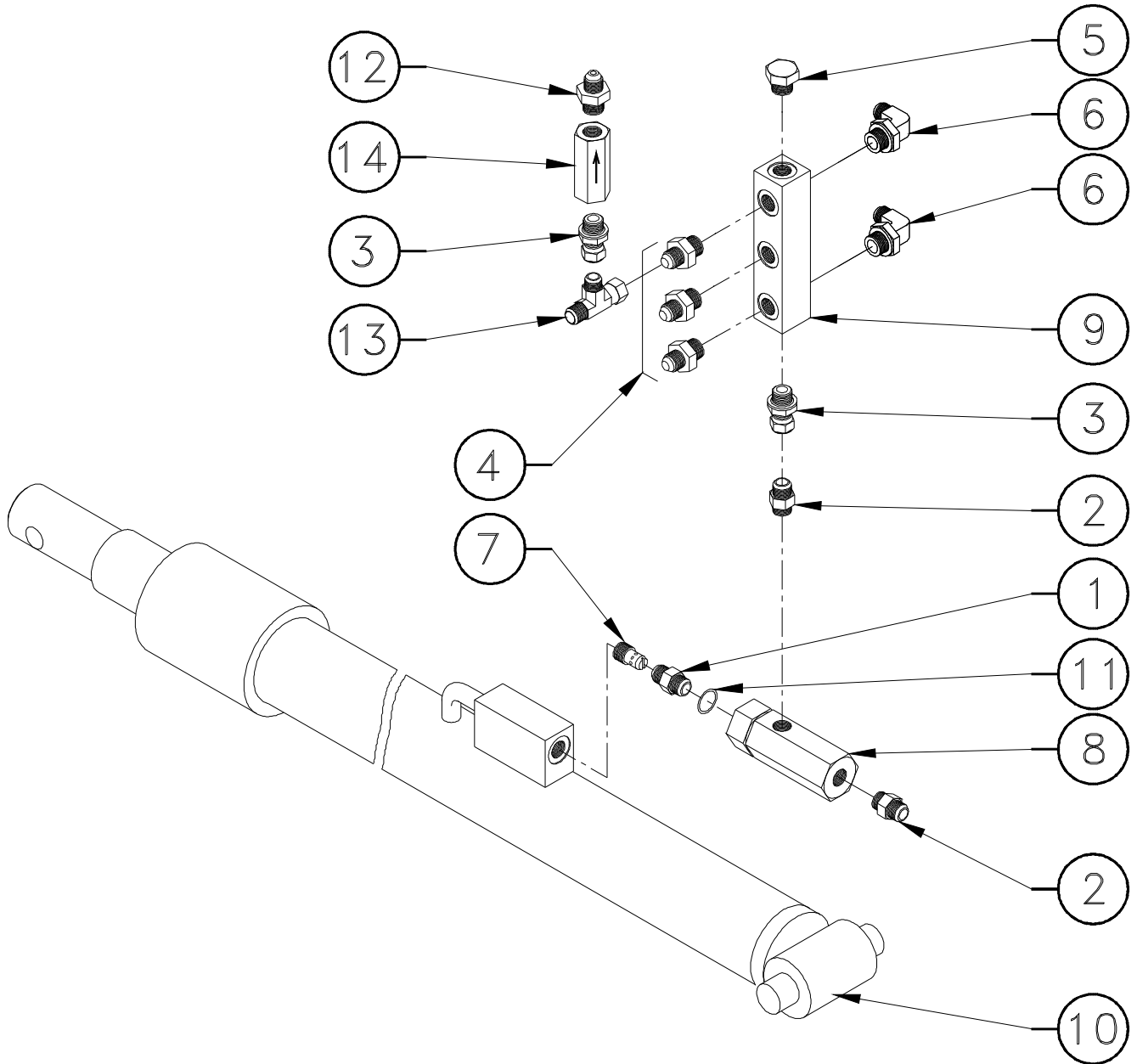

DATE : 12/05/99

MAST CYLINDER ASSEMBLY

MONTAGE N°/
ASSY NO : SP0221 REV : A

ASSEMBLAGE VERIN DE MAT

1/1

DET NO.	REF./PART NUMBER	VOIR/SEE VIEW	DESCRIPTION		REV	Qté/Qty Req.
1	300107		FITTING MALE BSPP 1/4- MALE BSPT 3/8	RAC. MALE BSPP 1/4-MALE BSPT 3/8	A	1
2	300025		FITTING MALE BSPP1/4-MALE JIC9/16	RACCORD MALE BSPP1/4-MALE JIC9/16		2
3	300027		FITTI. MALE BSPP3/8-FEM.JIC9/16 SWIVE	UNION MALE BSPP 3/8 -TOUR. JIC 9/16	A	2
4	300040		FITTING MALE BSPP3/8 MALE JIC9/16	RACCORD MALE BSPP3/8 MALE JIC9/16		3
5	300047		CAP BSPP 3/8	BOUCHON BSPP 3/8		1
6	300061		90° ELBOW MALE BSPP 3/8-MALE JIC 9/16	COUDE 90° MALE BSPP3/8-MALE JIC9/16		2
7	310037		FLOW REGULATOR VALVE 9L/mn	REGULATEUR DE DEBIT 9L/mn		1
8	320001		PILOT CHECK VALVE	CLAPET ANTI RETOUR PILOTE		1
9	520036		MANIFOLD	BLOC FORE		1
10		APPENDIX A	MAST CYLINDER	VERIN DE MAT		1
11	300108		BUSHING BS	BAGUE BS	A	1
12	300022		FITTING MALE BSPP 3/8- MALE JIC 7/16	RAC. MALE BSPP 3/8-MALE JIC 7/16	A	1
13	300037		RUN TEE JIC 9/16 SWIVEL NUT	TE MALE JIC9/16-FEMELLE JIC9/16 TOUR.	A	1
14	310023		CHECK VALVE 4.5 BAR BSPP 3/8	CLAPET ANTI RETOUR 4.5 BAR BSPP 3/8	A	1

LOWER VALVE ASSEMBLY ASSEMBLAGE DISTRIBUTEUR BAS

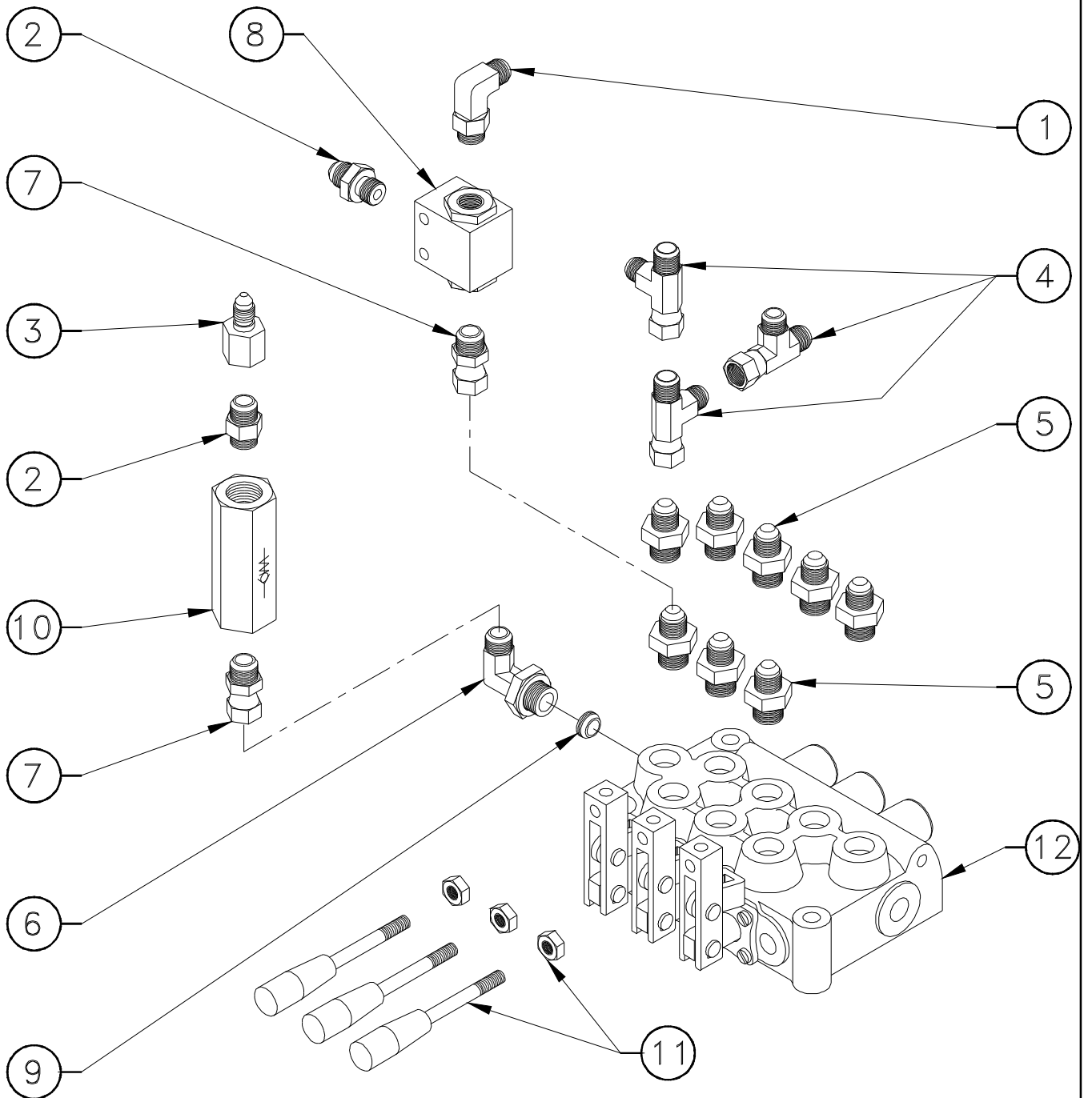

BULKHEAD ASSEMBLY ASSEMBLAGE TRAVERSEE DE CLOISON

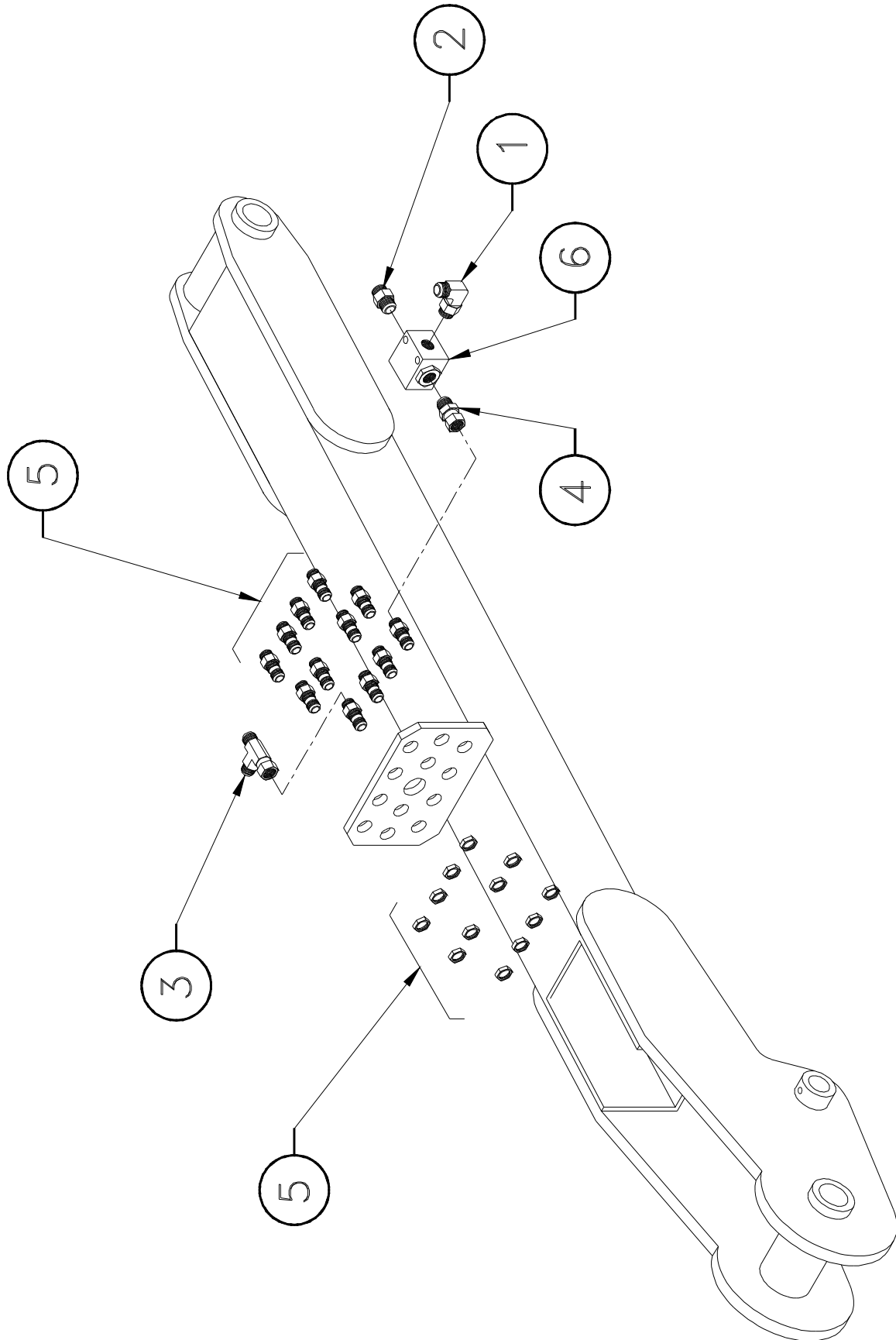

JIB CYLINDER ASSEMBLY ASSEMBLAGE VERIN DE BRAS

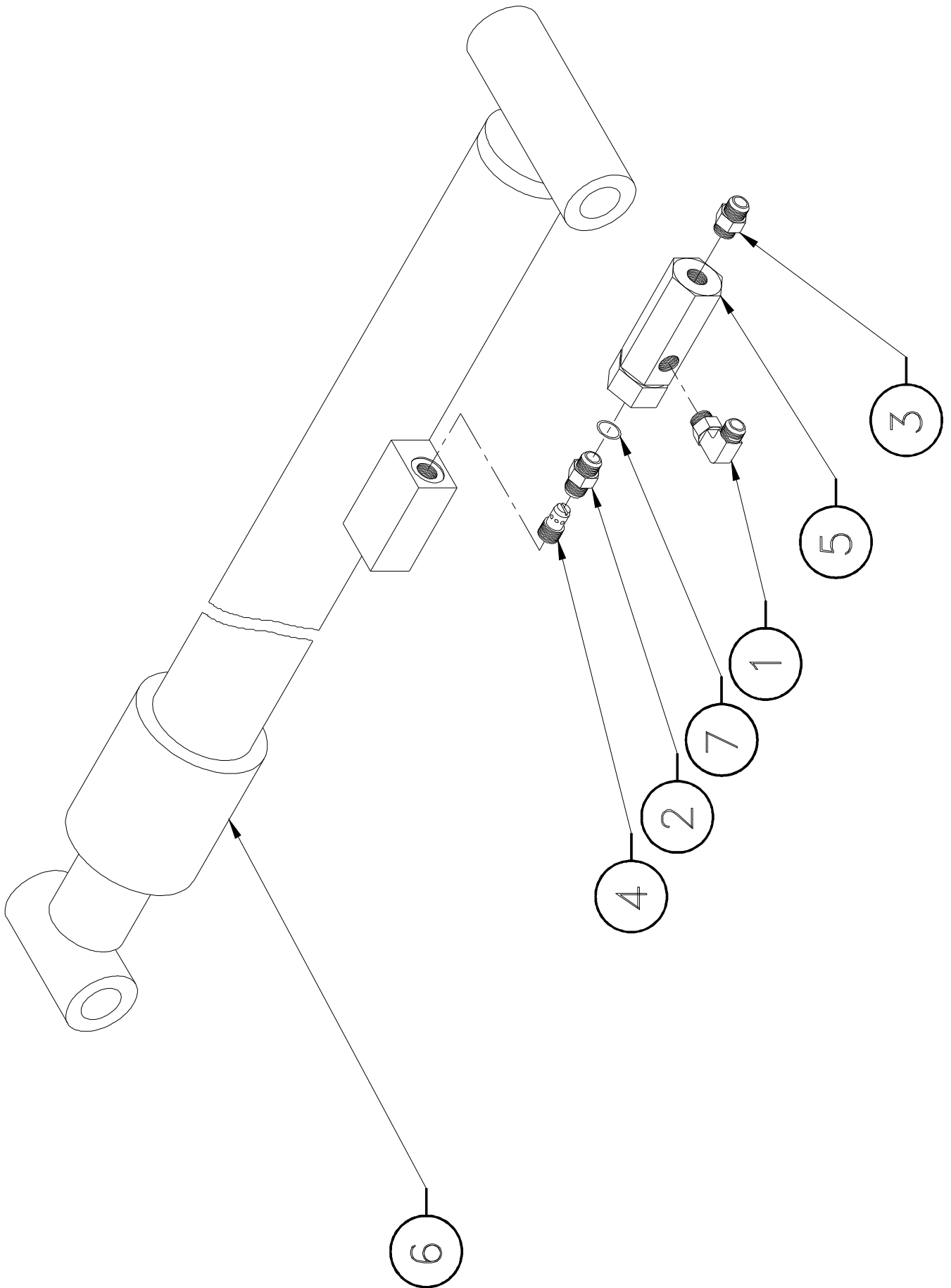

DATE : 25/08/99

JIB CYLINDER ASSEMBLY

MONTAGE N°/

ASSY NO : SP0238 REV : B

ASSEMBLAGE VERIN DE BRAS

1/1

DET NO.	REF./PART NUMBER	VOIR/ SEE VIEW	DESCRIPTION		R E V	Qté/ Qty Req.
1	300001		90° ELBOW MALE BSPP 1/4-MALE JIC 9/16	COUDE 90° Male BSPP 1/4 -Male JIC 9/16		1
2	300107		FITTING MALE BSPP 1/4- MALE BSPT 3/8	RAC. MALE BSPP 1/4-MALE BSPT 3/8	A	1
3	300025		FITTING MALE BSPP1/4-MALE JIC9/16	RACCORD MALE BSPP1/4-MALE JIC9/16		1
4	310058		PRESSURE FLOW REGULATOR VALVE	REGULATEUR DE DEBIT	B	1
5	320001		PILOT CHECK VALVE	CLAPET ANTI RETOUR PILOTE		1
6		APPENDIX A	JIB CYLINDER	VERIN DE BRAS		1
7	300108		BUSHING BS	BAGUE BS	A	1

JIB FLOW CONTROL ASSEMBLY ASSEMBLAGE ETRANGLEUR BRAS

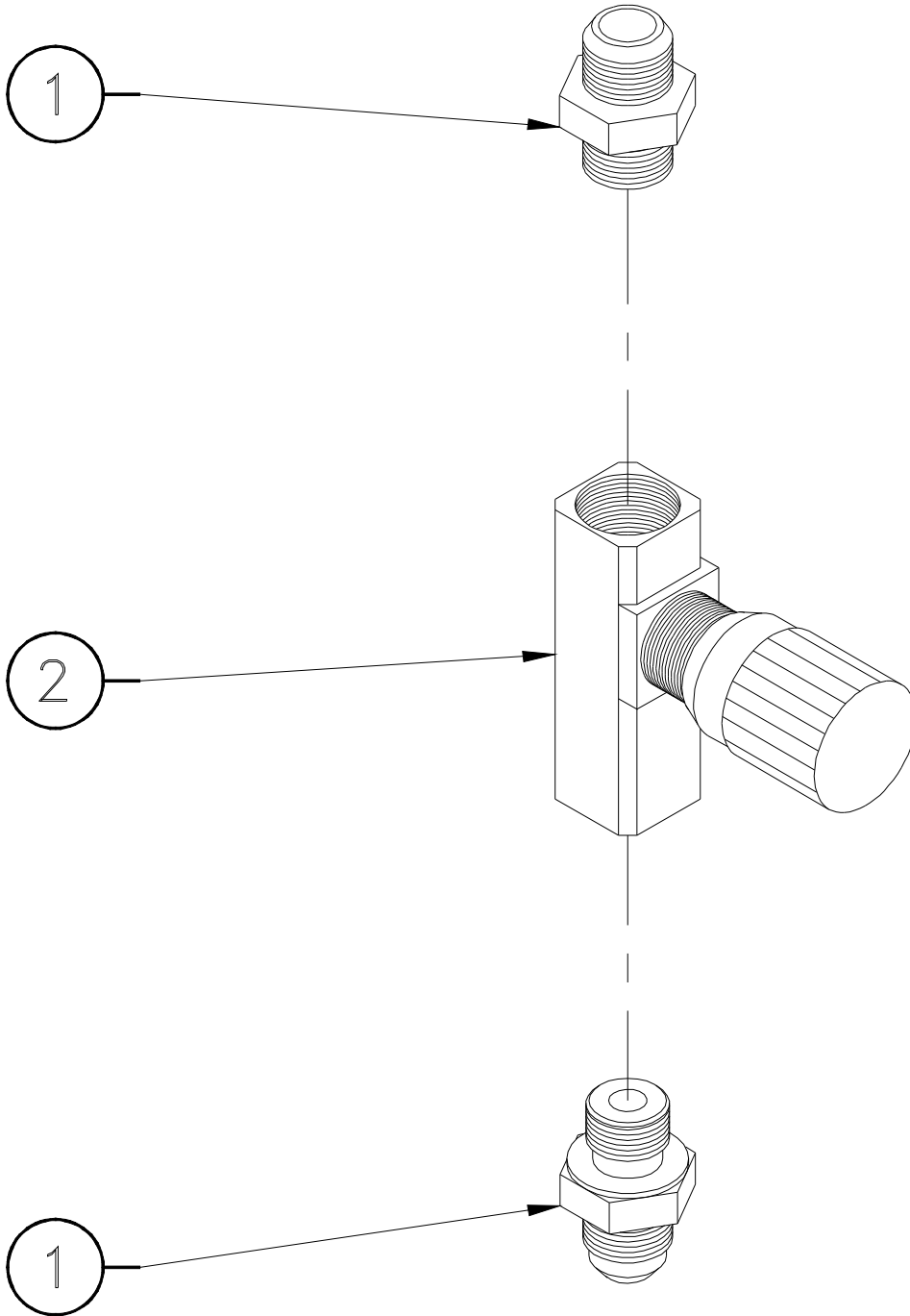

DATE : 15/01/98

JIB FLOW CONTROL ASSEMBLY

MONTAGE N°/
 ASSY NO : SP0239 REV :

ASSEMBLAGE ETRANGLEUR BRAS

1/1

DET NO.	REF./PART NUMBER	VOIR/ SEE VIEW	DESCRIPTION		R E V	Qté/ Qty Req.
1	300025		FITTING MALE BSPP1/4-MALE JIC9/16	RACCORD MALE BSPP1/4-MALE JIC9/16		2
2	310003		FLOW CONTROL VALVE	REGULATEUR DE DEBIT		1

HAND PUMP ASSEMBLY ASSEMBLAGE POMPE A MAIN

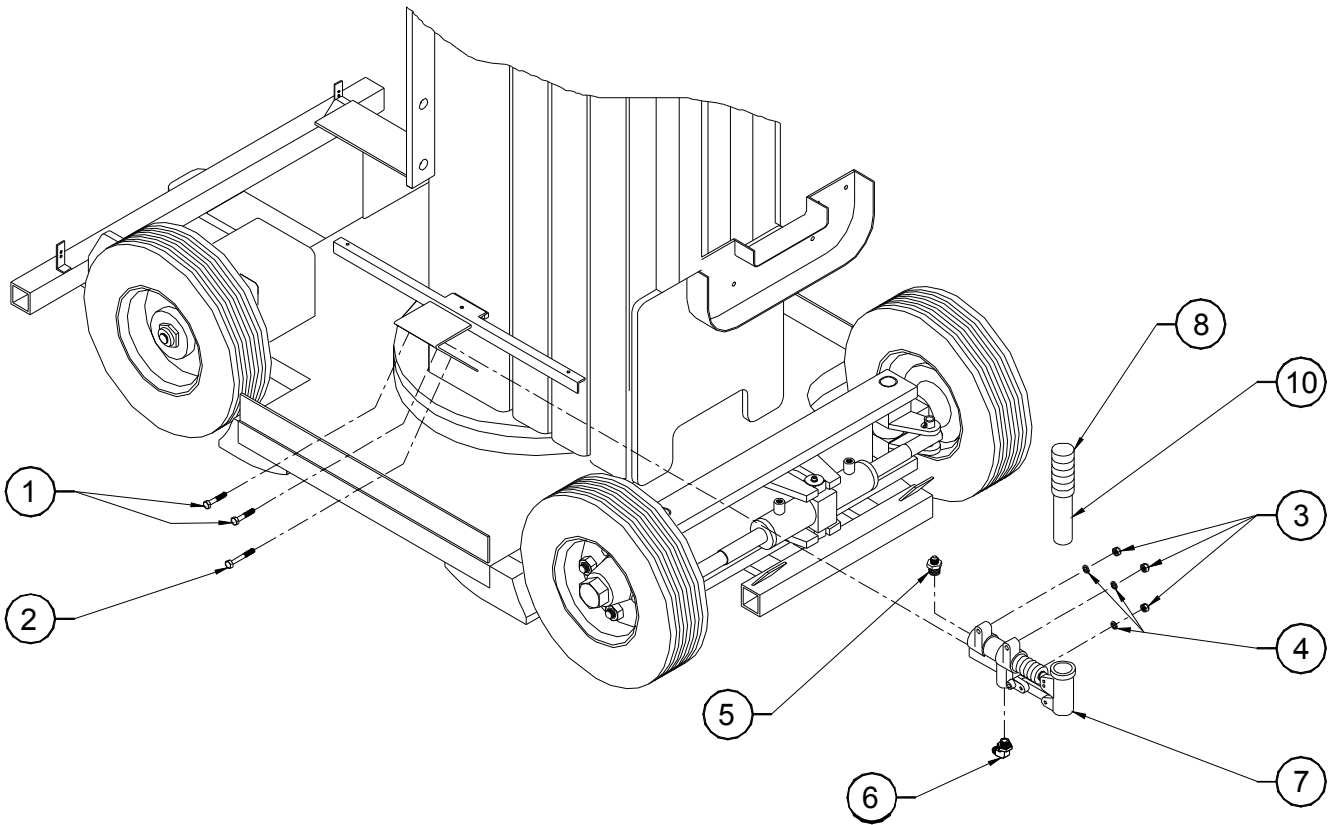

DATE : 11/12/06

HAND PUMP ASSEMBLY

MONTAGE N°/
ASSY NO : SP0240 REV : A

ASSEMBLAGE POMPE A MAIN

1/1

DET NO.	REF./PART NUMBER	VOIR/ SEE VIEW	DESCRIPTION		R E V	Qté/ Qty Req.
1	100093		M08x45 8.8 HEX HEAD MACHINE SCREW	VIS H M08x45 8.8 BI FT		2
2	100140		M08x60 8.8 HEX HEAD CAPSCREW	VIS H M08x60 8.8 BI FP		1
3	110004		M08 GR. 8.8 LOCK NUT	ECROU FREIN M8 8.8 BI		3
4	120010		dD 08x18 LOCK WASHER	RONDELLE CONTACT dD 08x18 BI		3
5	300044		FITTING MALE BSPP1/2-MALE JIC9/16	RACCORD MALE BSPP1/2-MALE JIC9/16		1
6	300061		90° ELBOW MALE BSPP 3/8-MALE JIC 9/16	COUDE 90° MALE BSPP3/8-MALE JIC9/16		1
7	320066		HAND PUMP	POMPE A MAIN	A	1
8	930109		PUMP HANDLE RUBBER	CAOUTCHOUC POIGNEE POMPE		1
9			NOT REQUIRED	NON REQUIS	A	1
10	DL0113		HAND PUMP HANDLE	MANCHE DE POMPE A MAIN		1

HYDRAULIC SCHEMATIC / SCHEMA HYDRAULIQUE

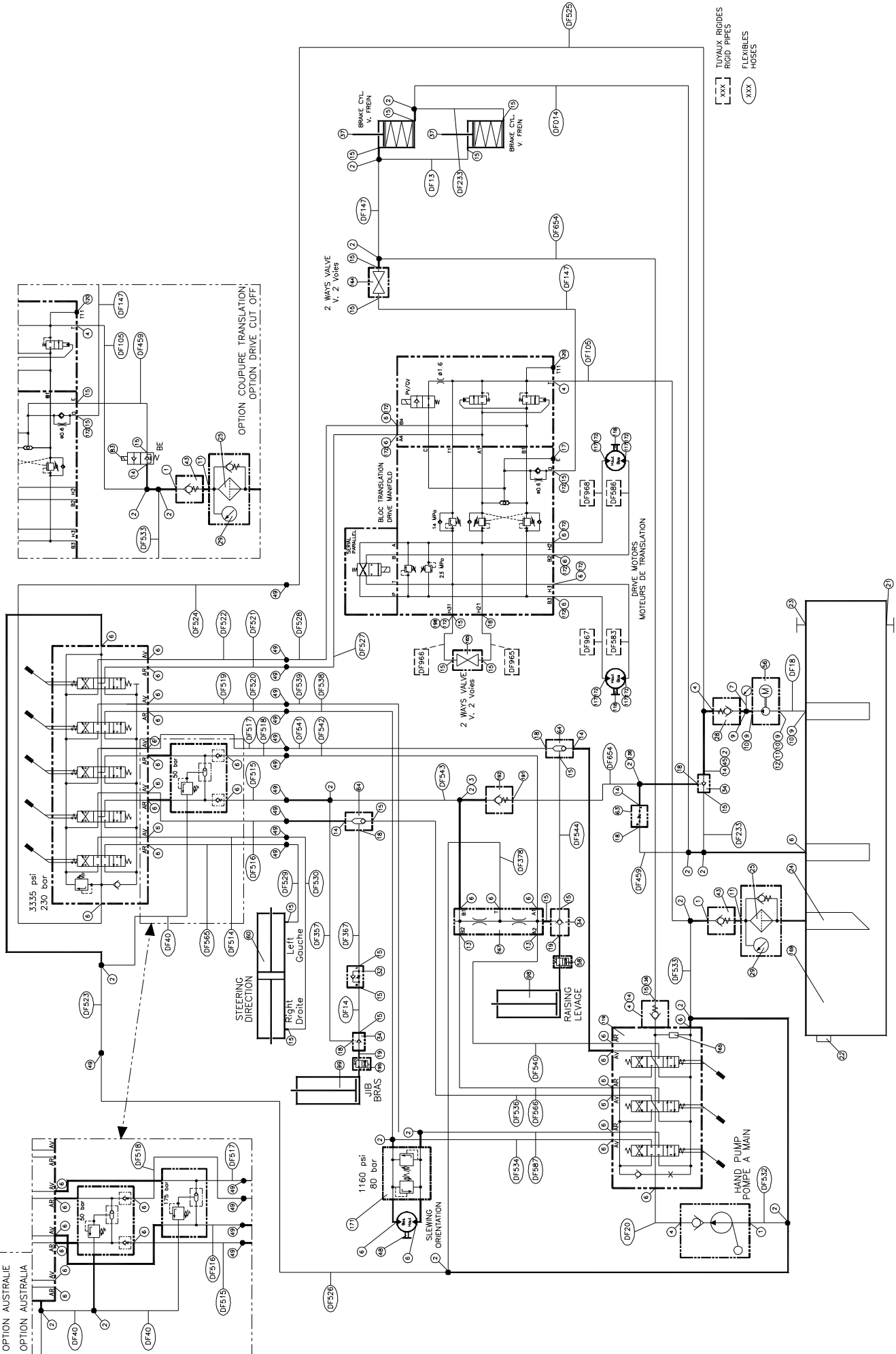

SPARE PARTS
PIECES DETACHEES

SECTION 7.

MAST INSTALL.
INSTALLATION DES MATS.



MAST INSTALL INSTALLATION DES MATS

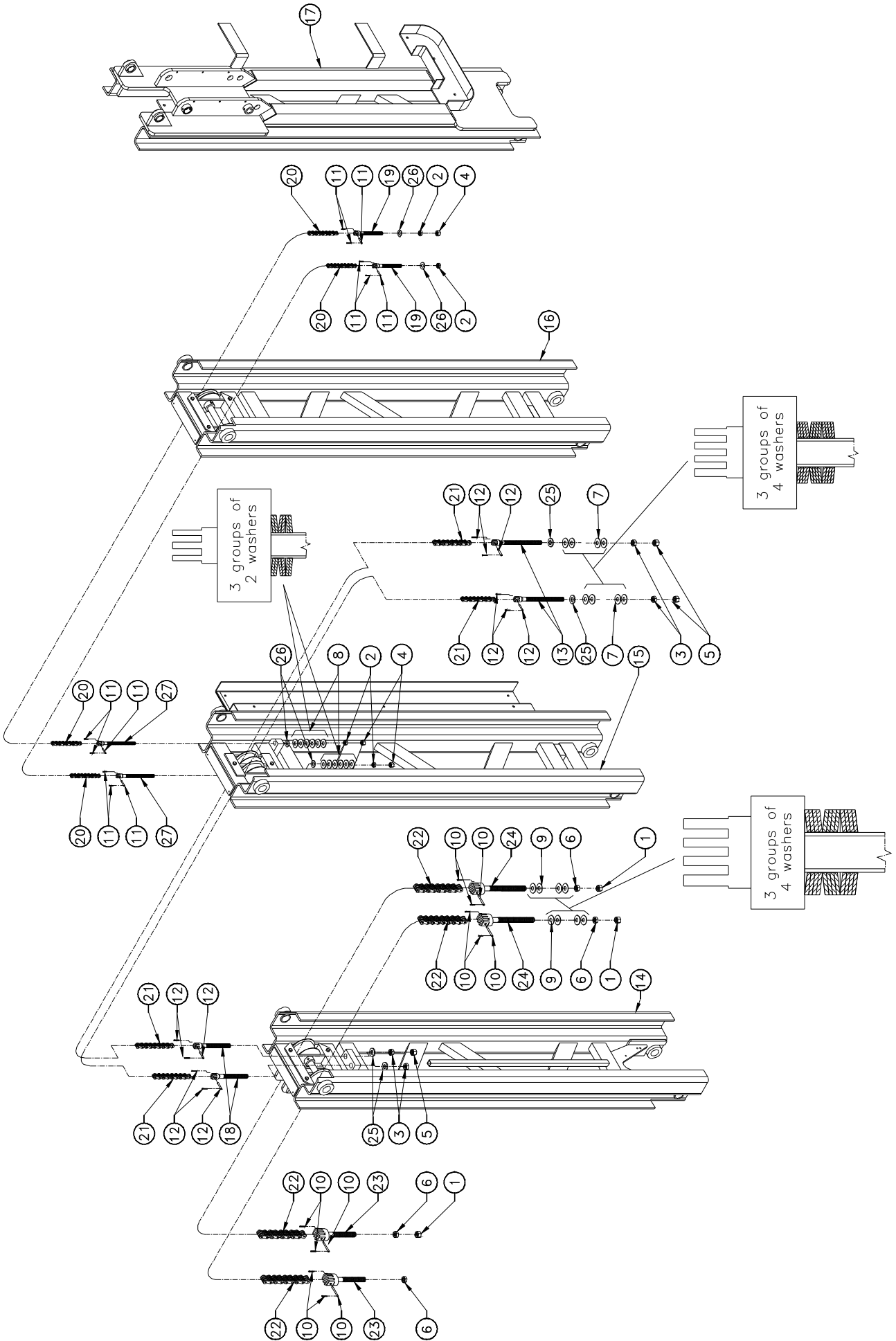

DATE : 05/12/97

MAST INSTALL

MONTAGE N°/
ASSY NO : SP0202 REV :

INSTALLATION MATS

1/1

DET NO.	REF P/N	VOIR/ SEE VIEW	DESCRIPTION		R E V	Qté/ Qty Req.
1	110006		M20 GR. 8.8 LOCK NUT	ECROU FREIN M20 8.8 BI		3
2	110009		M14 GR. 8.8 HEX NUT	ECROU H M14 8.8 BI		4
3	110010		M16 GR. 8.8 HEX NUT	ECROU H M16 8.8 BI		4
4	110019		M14 GR. 8.8 LOCK NUT	ECROU FREIN H M14 8.8 BI		3
5	110020		M16 GR. 8.8 LOCK NUT	ECROU FREIN M16		3
6	110025		M20 GR. 8.8 HEX NUT	ECROU H M20 8.8 BI		4
7	120006		Ø34x16.3x1.5 SPRING WASHER	RONDELLE RESSORT Ø34x16.3x1.5 BR		24
8	120017		SPRING WASHER Ø34x14.3x1.5	RONDELLE RESSORT Ø34x14.3x1.5 BR		12
9	120018		SPRING WASHER Ø40x20.4x2	RONDELLE RESSORT 40x20.4x2 BR		24
10	170002		M20 CLEVIS PIN	AXE DE CHAPE M20		4
11	170007		M14 CLEVIS PIN	AXE DE CHAPE M14		4
12	170008		M16 CLEVIS PIN	AXE DE CHAPE M16		4
13	170010		CHAIN ANCHOR M16x160	CHAPE DE CHAINE M16x160		2
14		SP0203	MAST 2 ASSEMBLY	ASSEMBLAGE MAT 2		1
15		SP0204	MAST 3 ASSEMBLY	ASSEMBLAGE MAT 3		1
16		SP0205	MAST 4 ASSEMBLY	ASSEMBLAGE MAT 4		1
17		SP0206	MAST 5 ASSEMBLY	ASSEMBLAGE MAT 5		1
18	ST0099		CHAIN ANCHOR M16x80	CHAPE DE CHAINE M16x80		2
19	ST0120		CHAIN ANCHOR M14x90	CHAPE DE CHAINE M14x90		2
20	ST1366		CHAIN LL 10-40	CHAINE DE LEVAGE LL 10-40		2
21	ST1365		CHAIN LL 12-66	CHAINE DE LEVAGE LL 12-66		2
22	ST1288		CHAIN LH 12-66	CHAINE DE LEVAGE LH 12-66		2
23	ST0752		CHAIN ANCHOR M20x80	CHAPE M20x80		2
24	ST0828		CHAIN ANCHOR M20x135	CHAPE M20x135		2
25	US0198		dDH 33x17x4 WASHER	RONDELLE dDH 33x17x4		4
26	120025		Ddh 28x14x2.5 WASHER	RONDELLE Ddh 28x14x2.5 BI		4
27	170009		M14x150 CHAIN ANCHOR	CHAPE DE CHAINE M14x150		2

DATE : 22/03/07

MAST 2 ASSEMBLY

MONTAGE N°/
 ASSY NO : SP0203 REV : B

ASSEMBLAGE MAT 2

1/1

DET NO.	REF./PART NUMBER	VOIR/ SEE VIEW	DESCRIPTION		RE V	Qté/ Qty Req.
1	100007		M08x50 8.8 HEX HEAD CAPSCREW	VIS H M08x50 8.8 BI FP		4
2	110004		M08 GR. 8.8 LOCK NUT	ECROU FREIN M8 8.8 BI		4
3	DL0374		MAST 2 WELDMENT	MAT 2		1
4	SE0495		ROLLER ASSEMBLY	ASSEMBLAGE GALET DE GUIDAGE	B	4
5	SE0765	SE0765	PULLEY ASSEMBLY LH12-66	ASSEMBLAGE SUPPORT POULIE LH12-66	B	1
6	US0026		M36 GR. 8.8 HEX NUT	ECROU M36 8.8		4

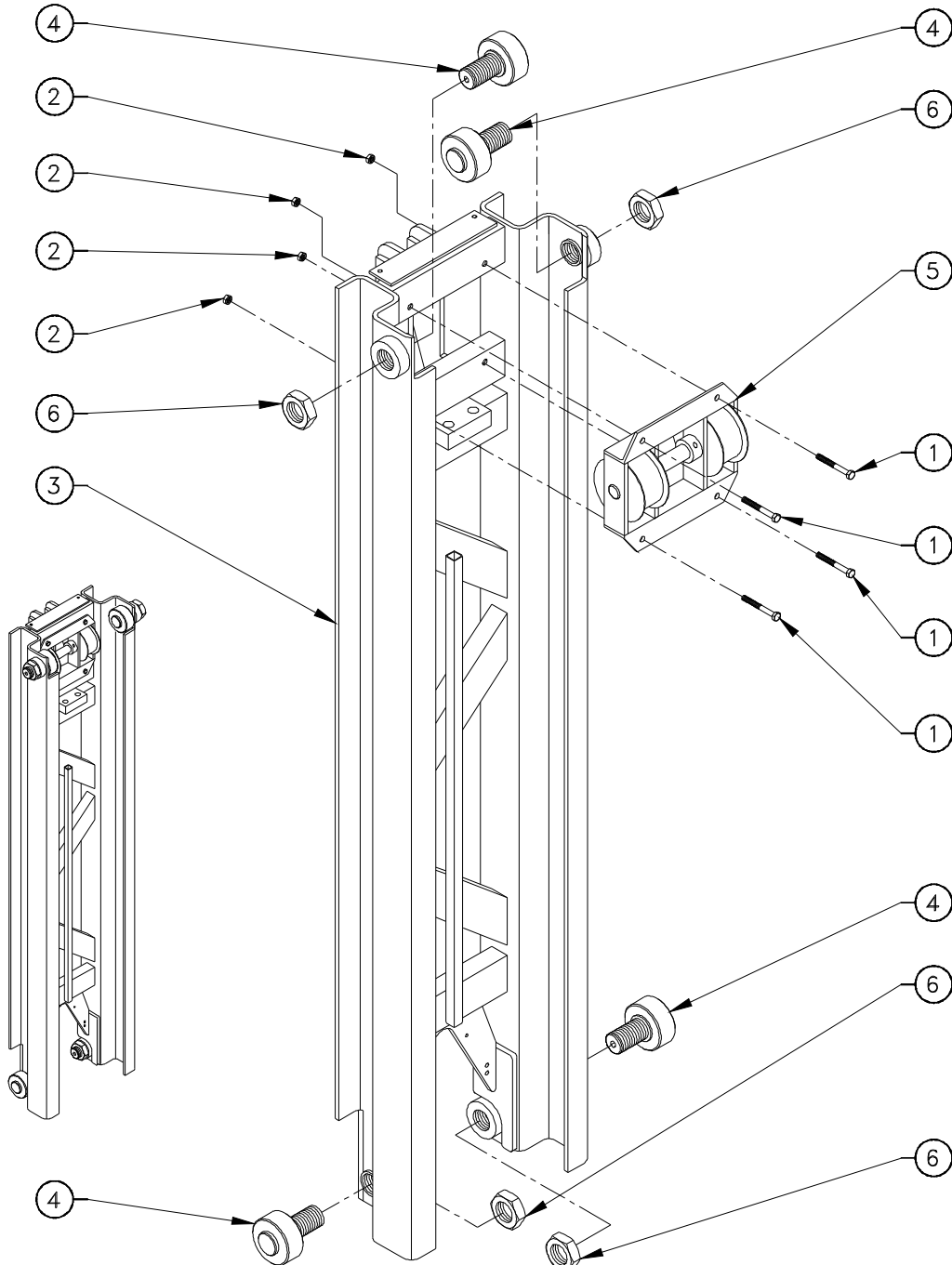

ISSUE DATE : 22/03/07

PULLEY ASSEMBLY LH12-66

ISSUE REL :

ASSEMBLY N° : SE0765 REV :
 N° ENSEMBLE :

ASSEMBLAGE SUPPORT POULIE LH12-66

1/1

DET REP	PART NUMBER REF.	SEE VIEW VOIR VUE	DESCRIPTION		R E V	QTY QTE
1	100013		M06x50 8.8 HEX HEAD CAPSCREW	VIS H M06x50 8.8 BI FP		1
2	110003		M06 GR. 8.8 LOCK NUT	ECROU FREIN M6 8.8 BI		1
3	150005		FLANGE BUSHING Ø25 H21.5 DU	BAGUE EPAULEE Ø25 H21.5 DU		4
4	ST0769		PULLEY MOUNT	SUPPORT POULIES		1
5	US0477		PULLEY	POULIE		2
6	US0200		PULLEY PIN	AXE DE SUPPORT POULIES		1

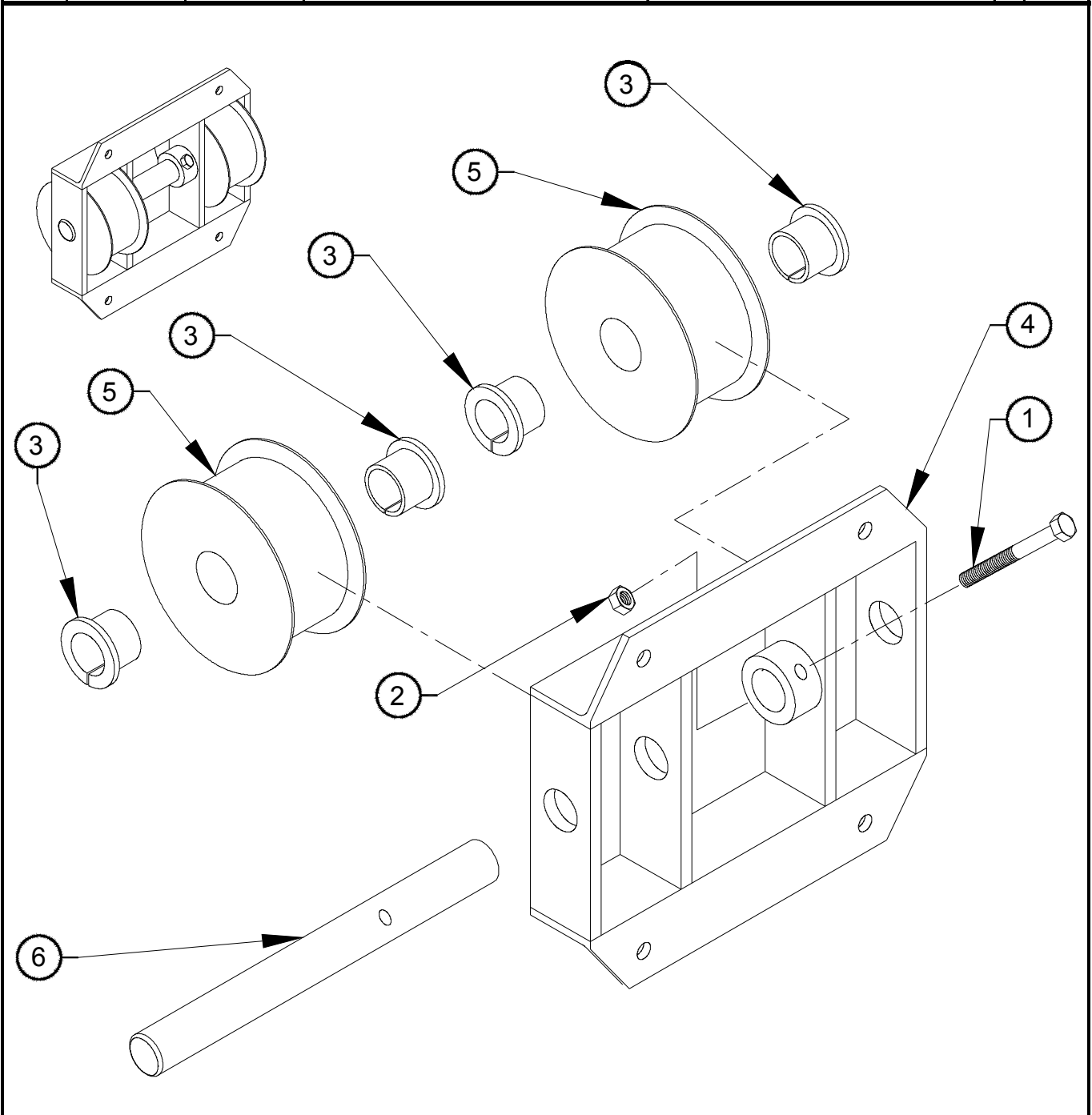

DATE : 22/03/07

MAST 3 ASSEMBLY

MONTAGE N°/
 ASSY NO : SP0204 REV : B

ASSEMBLAGE MAT 3

1/1

DET NO.	REF./PART NUMBER	VOIR/ SEE VIEW	DESCRIPTION		RE V	Qté/ Qty Req.
1	100007		M08x50 8.8 HEX HEAD CAPSCREW	VIS H M08x50 8.8 BI FP		2
2	110004		M08 GR. 8.8 LOCK NUT	ECROU FREIN M8 8.8 BI		2
3	DL0375		MAST 3 WELDMENT	MAT 3		1
4	SE0495		ROLLER ASSEMBLY	ASSEMBLAGE GALET DE GUIDAGE	B	4
5	SE0766	SE0766	PULLEY ASSEMBLY LL12-66	ASSEMBLAGE SUPPORT POULIE LL12-66	B	1
6	US0026		M36 GR. 8.8 HEX NUT	ECROU M36 8.8		4

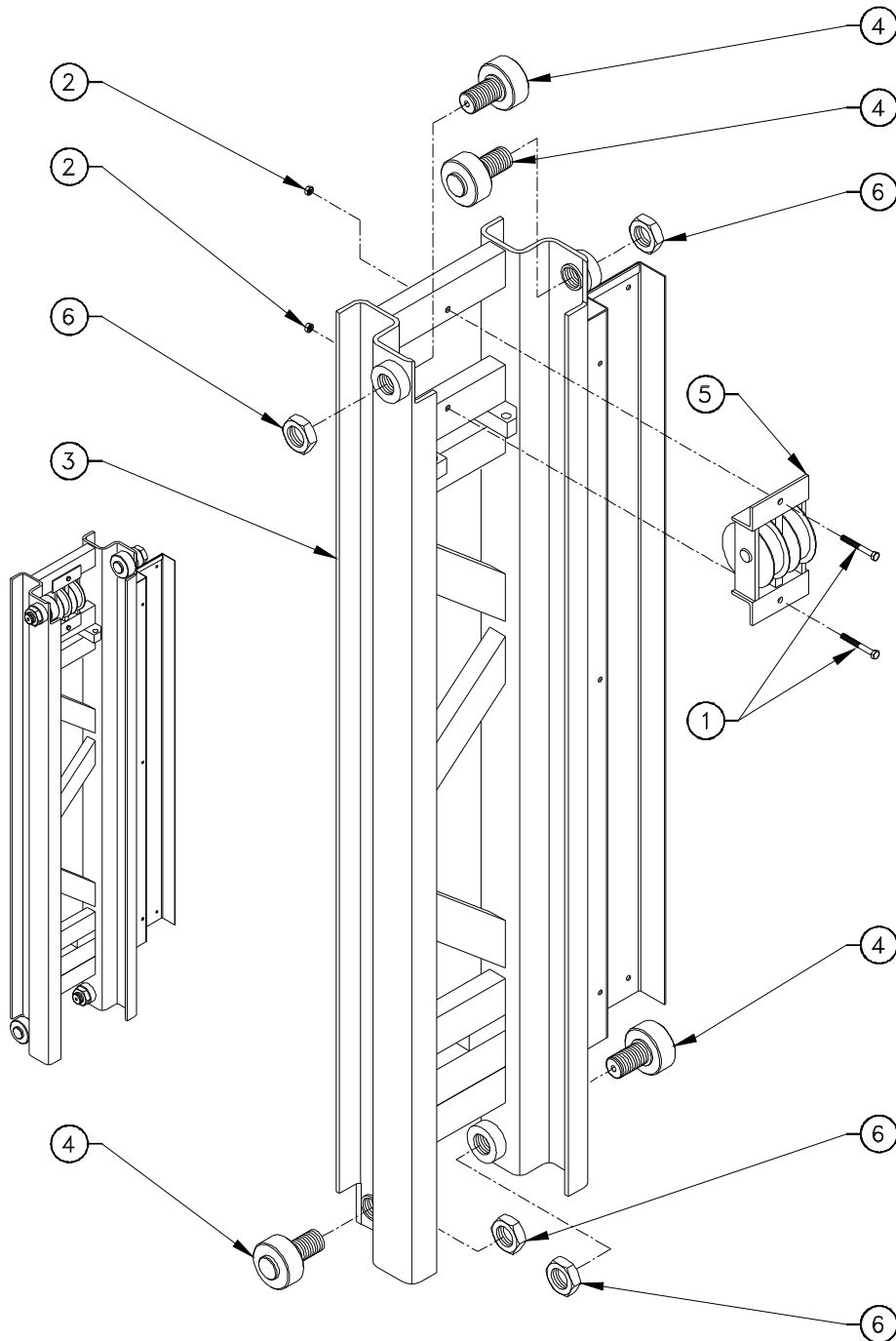

ISSUE DATE : 22/03/07

PULLEY ASSEMBLY LL12-66

ISSUE REL :

ASSEMBLY N° : SE0766 REV :
 N° ENSEMBLE :

ASSEMBLAGE SUPPORT POULIE LL12-66

1/1

DET REP	PART NUMBER REF.	SEE VIEW VOIR VUE	DESCRIPTION		R E V	QTY QTE
1	100013		M06x50 8.8 HEX HEAD CAPSCREW	VIS H M06x50 8.8 BI FP		1
2	110003		M06 GR. 8.8 LOCK NUT	ECROU FREIN M6 8.8 BI		1
3	150011		FLANGE BUSHING Ø25 H11.5 DU	BAGUE EPAULEE Ø25 H11.5 DU		4
4	ST0767		PULLEY MOUNT	SUPPORT POULIES		1
5	US0476		BIG PULLEY	GROSSE POULIE		2
6	US0195		PULLEY PIN	AXE DE SUPPORT POULIES		1

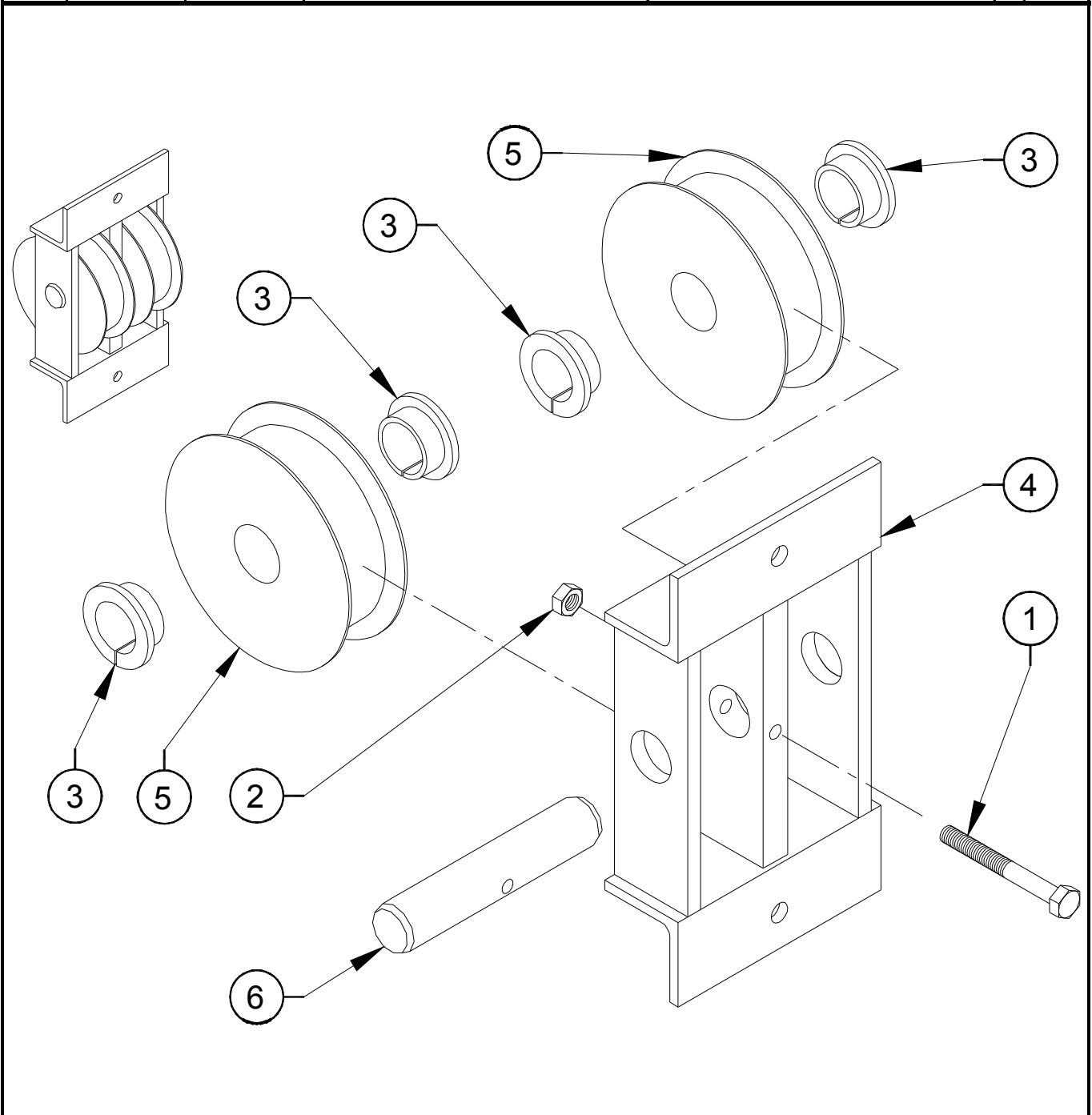

DATE : 22/03/07

MAST 4 ASSEMBLY

MONTAGE N°/
 ASSY NO : SP0205 REV : B

ASSEMBLAGE MAT 4

1/1

DET NO.	REF./PART NUMBER	VOIR/ SEE VIEW	DESCRIPTION		RE V	Qté/ Qty Req.
1	100007		M08x50 8.8 HEX HEAD CAPSCREW	VIS H M08x50 8.8 BI FP		4
2	110004		M08 GR. 8.8 LOCK NUT	ECROU FREIN M8 8.8 BI		4
3	DL0376		MAST 4 WELDMENT	MAT 4		1
4	SE0495		ROLLER ASSEMBLY	ASSEMBLAGE GALET DE GUIDAGE	B	4
5	SE0767	SE0767	PULLEY ASSEMBLY LL10-40	ASSEMBLAGE SUPPORT POULIE LL10-40	B	1
6	US0026		M36 GR. 8.8 HEX NUT	ECROU M36 8.8		4

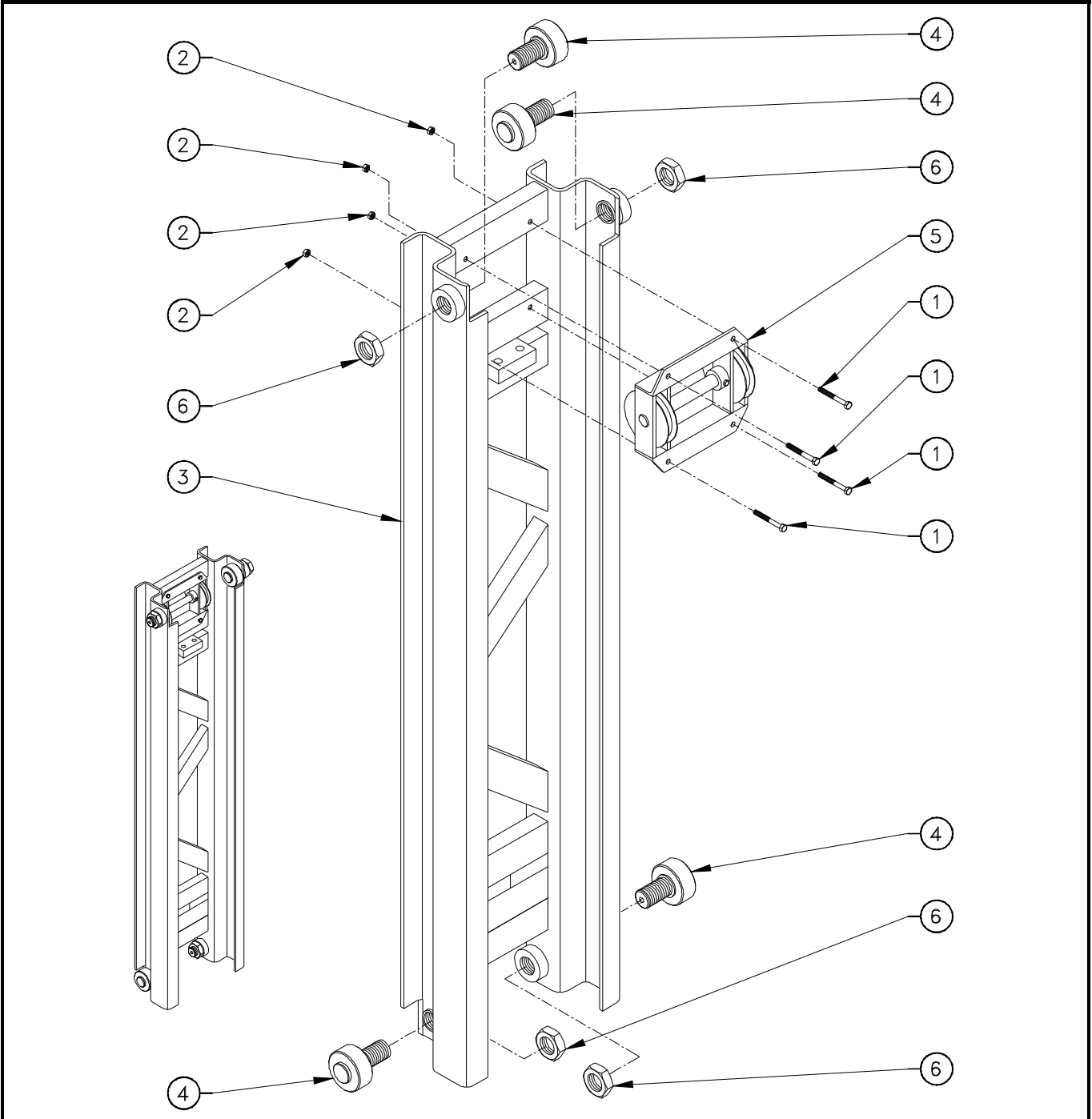

ISSUE DATE : 22/03/07

PULLEY ASSEMBLY LL10-40

ISSUE REL :

ASSEMBLY N° : SE0767 REV :
 N° ENSEMBLE :

ASSEMBLAGE SUPPORT POULIE LL10-40

1/1

DET REP	PART NUMBER REF.	SEE VIEW VOIR VUE	DESCRIPTION		R E V	QTY QTE
1	100013		M06x50 8.8 HEX HEAD CAPSCREW	VIS H M06x50 8.8 BI FP		1
2	110003		M06 GR. 8.8 LOCK NUT	ECROU FREIN M6 8.8 BI		1
3	150011		FLANGE BUSHING Ø25 H11.5 DU	BAGUE EPAULEE Ø25 H11.5 DU		4
4	SD0171		PULLEY MOUNT	SUPPORT POULIES		1
5	US0475		LL10-44 PULLEY	POULIE LL10-44		2
6	US0142		PULLEY PIN	AXE DE SUPPORT POULIES		1

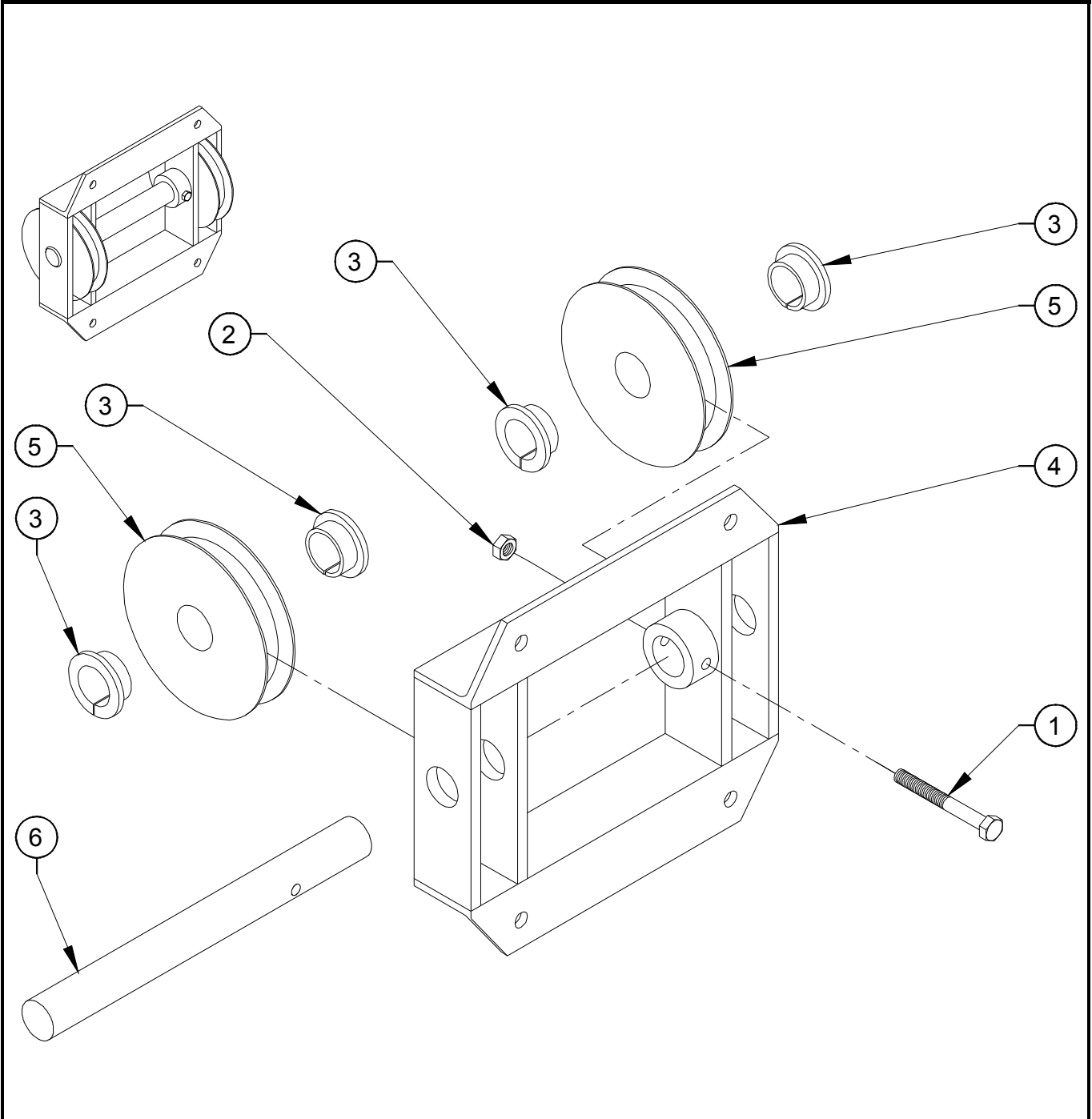

DATE : 12/03/08

MAST 5 ASSEMBLY

MONTAGE N°/
 ASSY NO : SP0206 REV : B

ASSEMBLAGE MAT 5

1/1

DET NO.	REF./PART NUMBER	VOIR/SEE VIEW	DESCRIPTION		REVIEW	Qté/Qty Req.
1	150023		BUSHING Ø25 H30 DX	BAGUE Ø25 H30 DX		2
2	DL0377		MAST 5 WELDMENT	MAT 5		1
3	SE0495		ROLLER ASSEMBLY	ASSEMBLAGE GALET DE GUIDAGE	B	2
4	US0026		M36 GR. 8.8 HEX NUT	ECROU M36 8.8		2

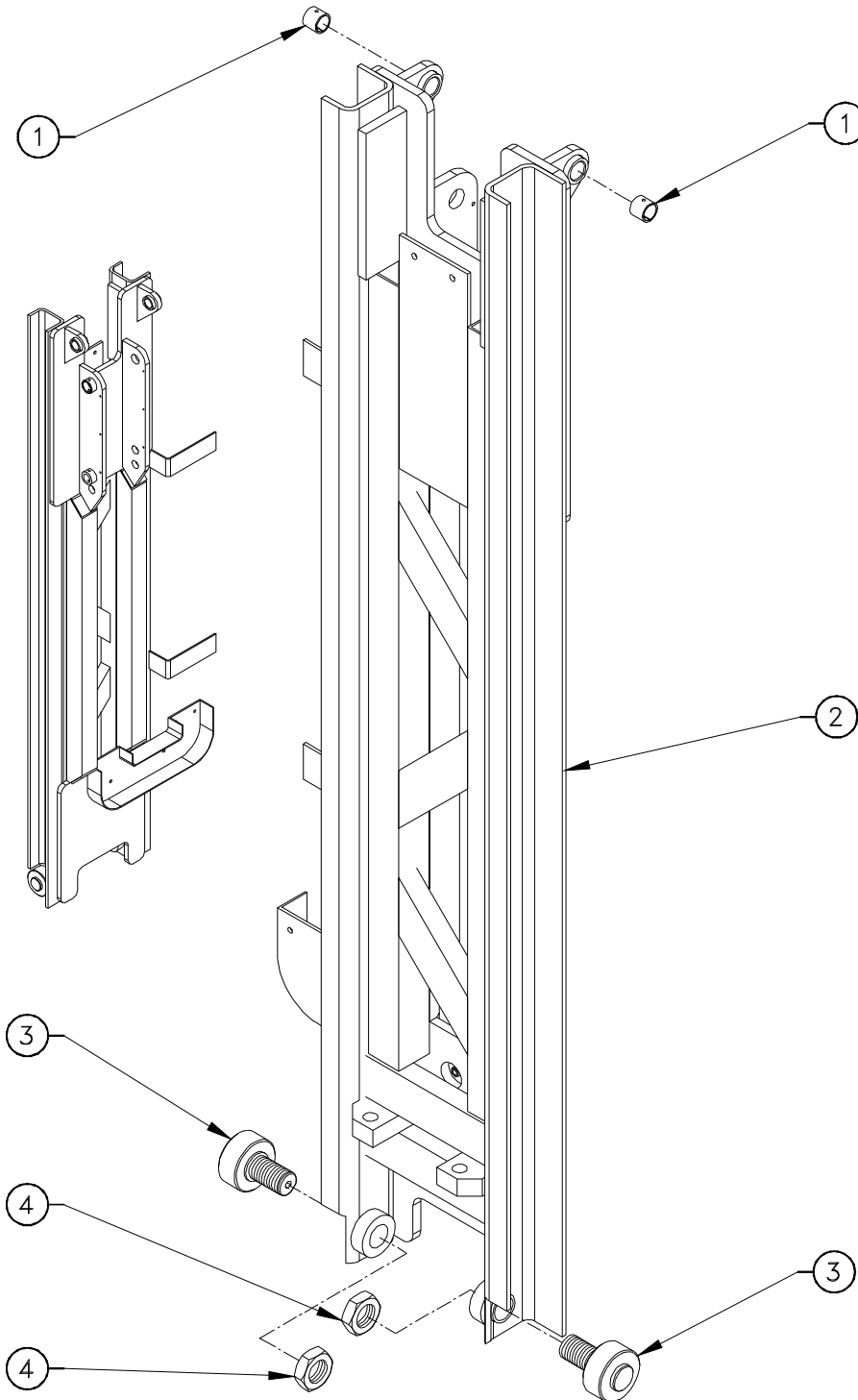

**SPARE PARTS
PIECES DETACHEES**

SECTION 8.

**TURNTABLE INSTALL.
INSTALLATION TOURELLE.**



TURNTABLE INSTALL INSTALLATION TOURELLE

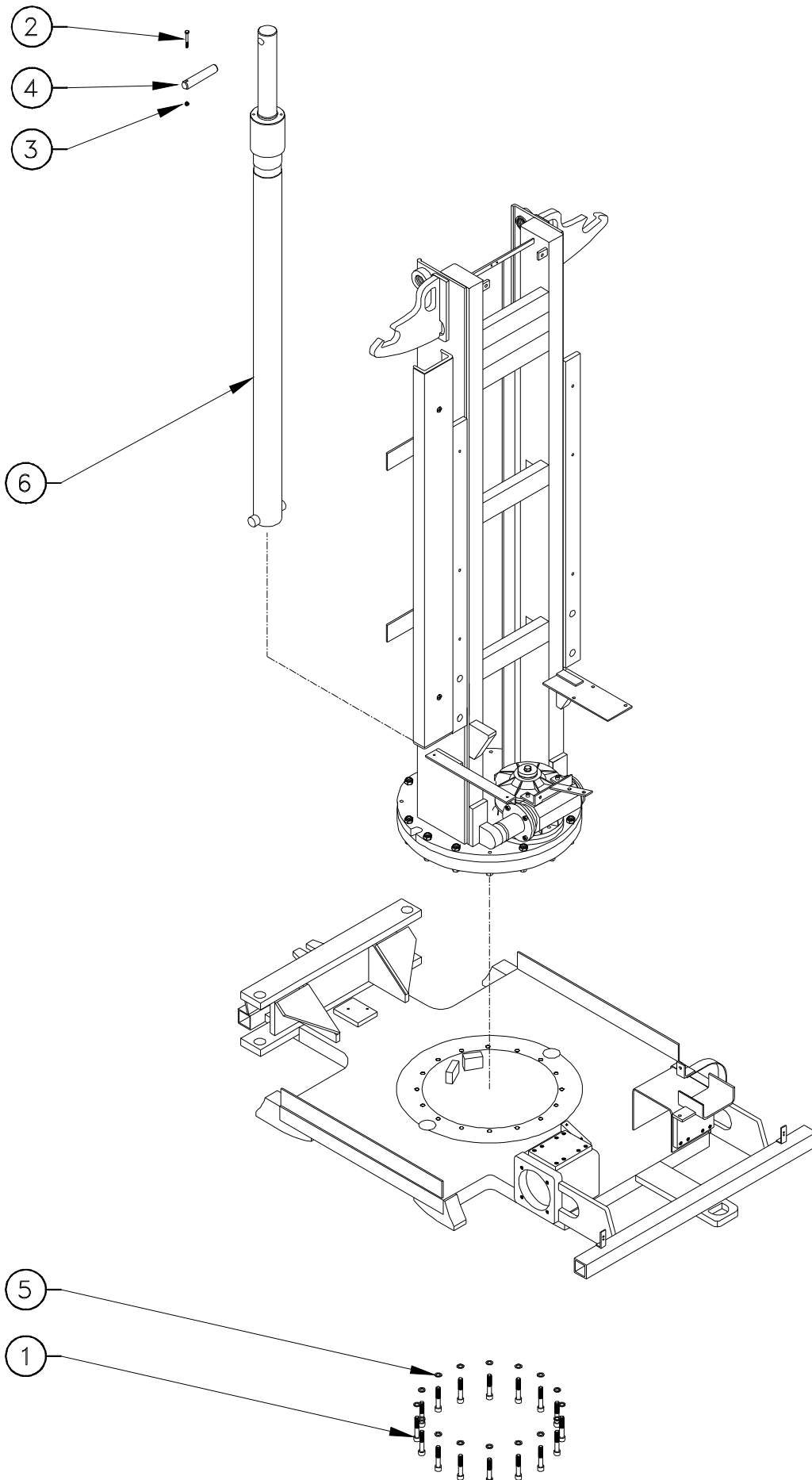

SPARE PARTS
PIECES DETACHEES

SECTION 9.

FRAME INSTALL.
INSTALLATION CHASSIS.



FRAME INSTALL INSTALLATION CHASSIS

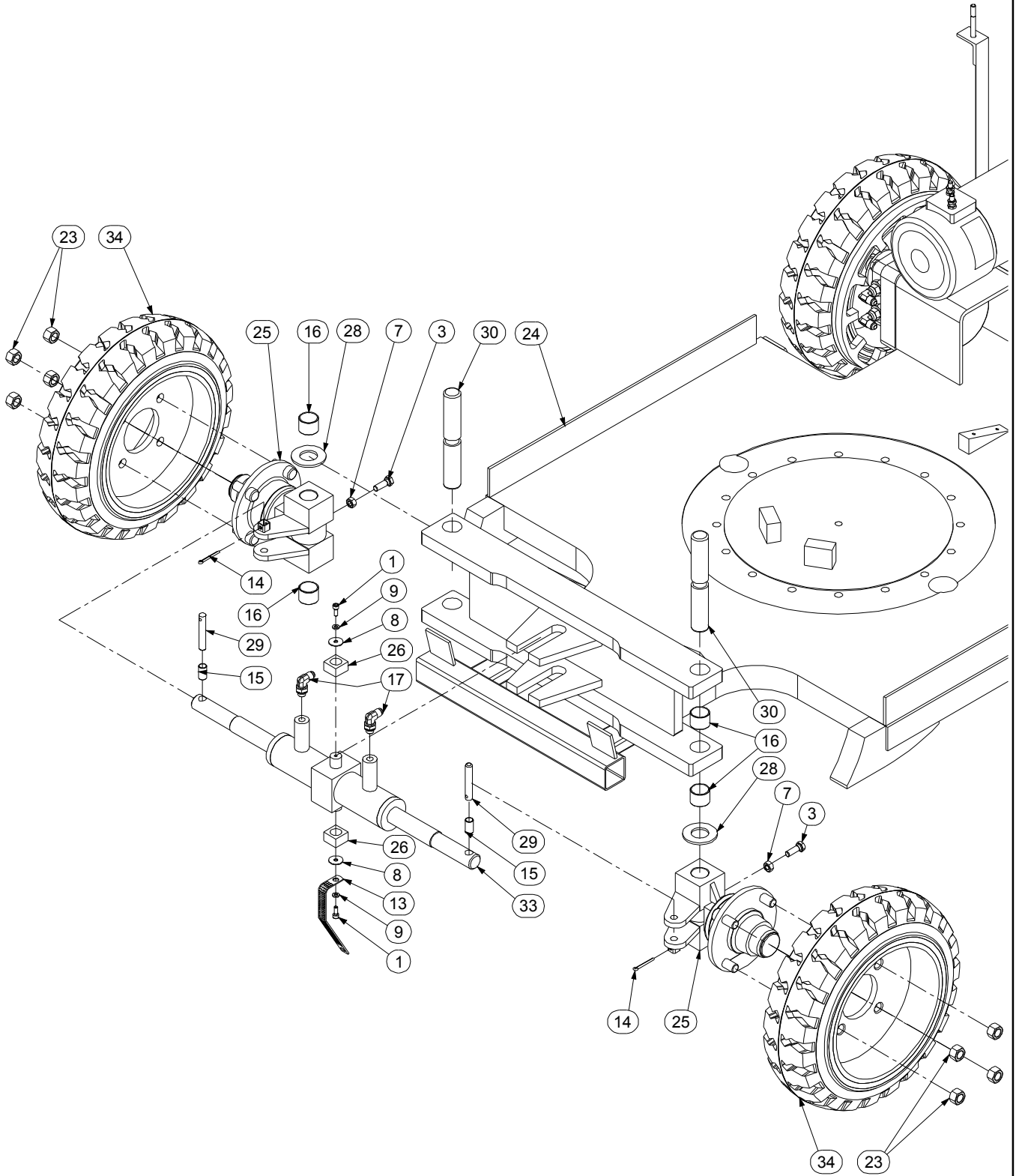

FRAME INSTALL INSTALLATION CHASSIS

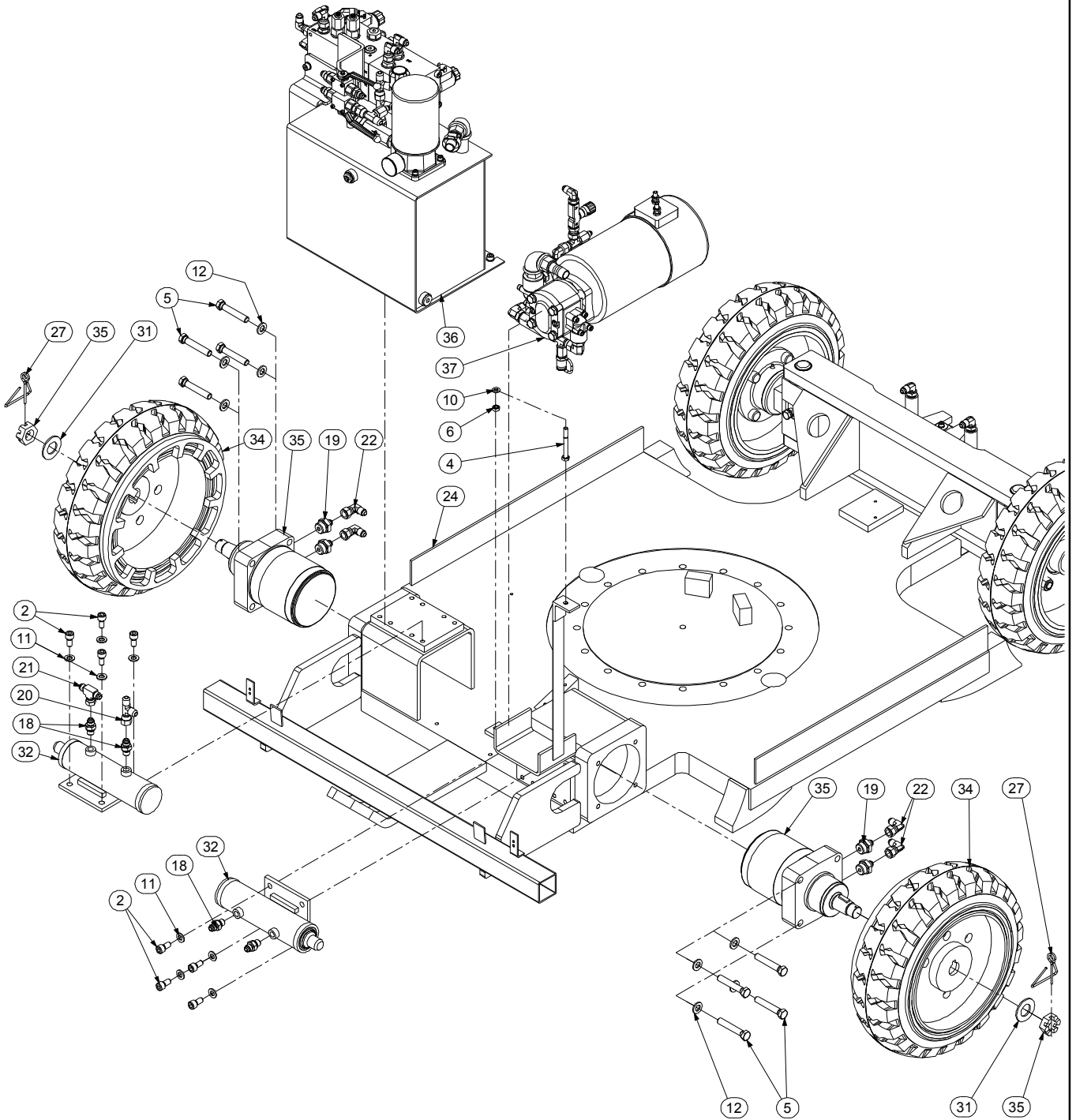

ISSUE DATE : 12/03/08

FRAME INSTALL

ISSUE REL :

ASSEMBLY N° : SP0214 REV : A
N° ENSEMBLE :**INSTALLATION CHASSIS**

1/1

DET REP	PART NUMBER REF.	SEE VIEW VOIR VUE	DESCRIPTION		R E V	QTY QTE
1	000015		M06x16 8.8 SOCKET HEAD MACH SCREW	VIS CHC M06x16 8.8 BI FT		2
2	000028		M10x20 8.8 SOCKET HEAD MACH SCREW	VIS CHC M10x20 8.8 BI FT		8
3	100009		M10x30 8.8 HEX HEAD MACHINE SCREW	VIS H M10x30 8.8 BI FT		2
4	100025		M08x70 8.8 HEX HEAD CAPSCREW	VIS H M08x70 8.8 BI FP		1
5	100075		M12x70 8.8 HEX HEAD MACHINE SCREW	VIS H M12x70 8.8 BI FT		8
6	110004		M08 GR. 8.8 LOCK NUT	ECROU FREIN M8 8.8 BI		1
7	110008		M10 GR. 8.8 HEX NUT	ECROU H M10 8.8 BI		2
8	120004		dD 06x25 WASHER	RONDELLE dD 06x25x1.2 BI		2
9	120009		dD 06x14 LOCK WASHER	RONDELLE CONTACT dD 06x14 BI		2
10	120010		dD 08x18 LOCK WASHER	RONDELLE CONTACT dD 08x18 BI		1
11	120011		dD 10x22 LOCK WASHER	RONDELLE CONTACT dD 10x22 BI		8
12	120015		dD 12x27 LOCK WASHER	RONDELLE CONTACT dD 12x27 BI		8
13	130022		STATIC STRAP	TRESSE DE MASSE		1
14	140019		Ø4x40 COTTER PIN	GOUPILLE FENDUE Ø4x40		2
15	150015		BUSHING Ø12 H25 DU	BAGUE Ø12 H25 DU		2
16	150019		BUSHING Ø30 H25 DU	BAGUE Ø30 H25 DU		4
17	300001		90° ELBOW MALE BSPP 1/4-MALE JIC 9/16	COUDE 90° Male BSPP 1/4 -Male JIC 9/16		2
18	300025		FITTING MALE BSPP1/4-MALE JIC9/16	RACCORD MALE BSPP1/4-MALE JIC9/16		4
19	300036		FITTING MALE UNF 7/8-MALE JIC 9/16	RACCORD MALE UNF 7/8-MALE JIC 9/16		4
20	300037		RUN TEE JIC 9/16 SWIVEL NUT	TE MALE JIC9/16-FEMELLE JIC9/16 TOUR.		1
21	300055		BRANCH TEE MALE JIC 9/16 SWIVEL NUT	TE Male JIC9/16 TOURNANT CENTRAL		1
22	300067		90° ELBOW M JIC9/16 F JIC9/16 SWIVEL	COUDE Male JIC9/16 Fem JIC9/16 Tournant		4
23	920026		M16x150 HEX NUT	ECROU H M16x150		8
24	DL0350		FRAME	CHASSIS		1
25	DL0414		STEERING SPINDLE	FUSEE DE DIRECTION		2
26	ST0258		CYLINDER BUSHING	BAGUE VERIN		2
27	ST2110		PIN	GOUPILLE		2
28	US0134		THRUST WASHER	RONDELLE D'APPUI		2
29	US0215		STEERING CYLINDER PIN	AXE DE VERIN DE DIRECTION		2
30	US0216		SPINDLE PIN	AXE DE FUSEE		2
31	US0392		WASHER	RONDELLE		2
32		APPENDIX A	BRAKE CYLINDER	VERIN FREIN		1
33		APPENDIX A	STEERING CYLINDER	VERIN DE DIRECTION		1
34		APPENDIX D	TIRE AND WHEEL INSTALL	INSTALLATION DES ROUES		1
35		APPENDIX E	HYDRAULIC MOTORS INSTALL	INSTALLATION DES MOTEURS		1
36		SP0208	HYDRAULIC RESERVOIR INSTALL	INSTALLATION DU RESERVOIR		1
37		SP0218	PUMP/MOTOR INSTALL	INSTALLATION DE LA CENTRALE		1

HYDRAULIC RESERVOIR INSTALL INSTALLATION DU RESERVOIR

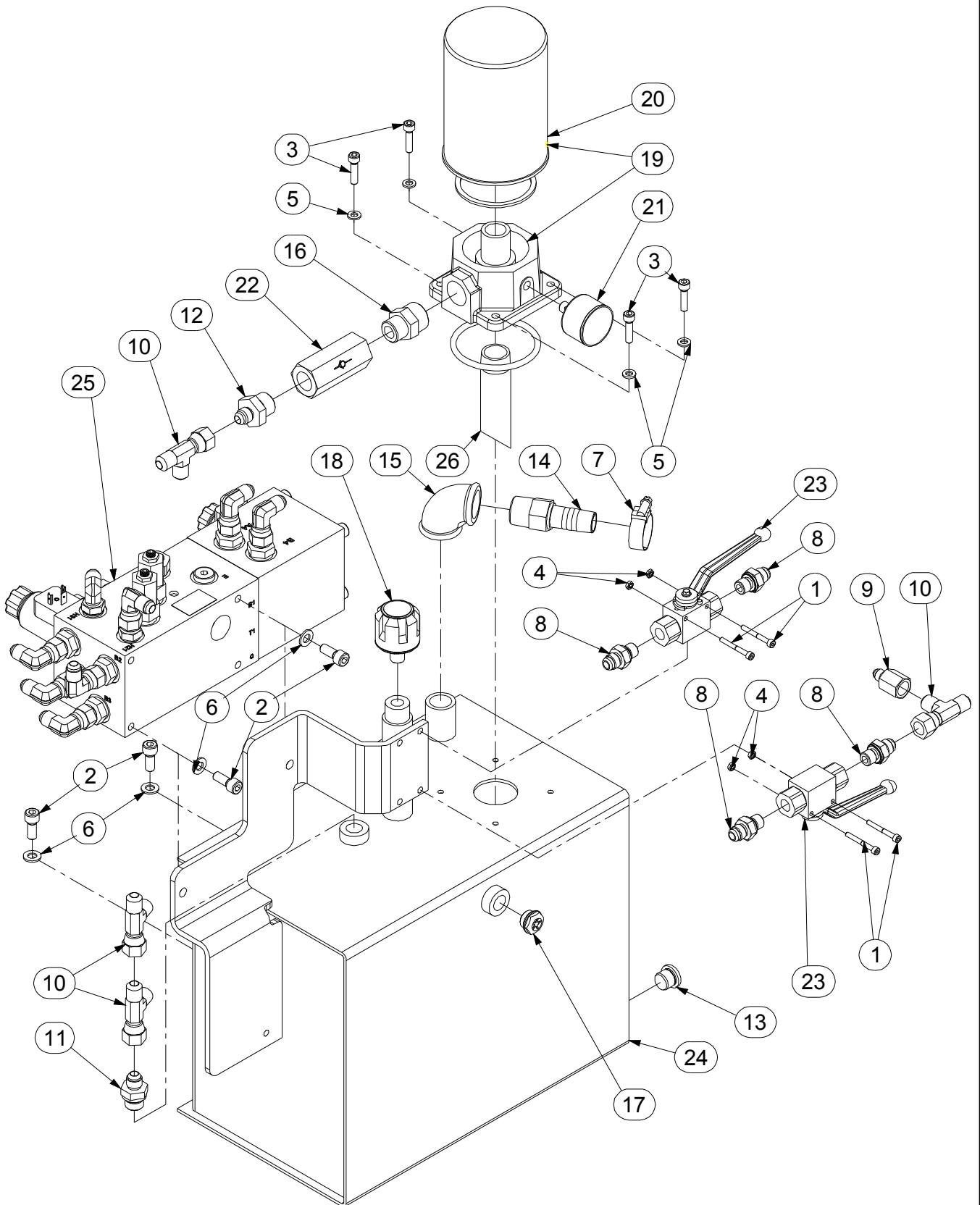

ISSUE DATE : 13/03/08

HYDRAULIC RESERVOIR INSTALL

ISSUE REL :

ASSEMBLY N° :
N° ENSEMBLE : SP0208 REV : C**INSTALLATION DU RESERVOIR**

1/1

DET REP	PART NUMBER REF.	SEE VIEW VOIR VUE	DESCRIPTION		R E V	QTY QTE
1	000004		M04x35 8.8 SOCK. HEAD MACH. SCREW	VIS CHC M04x35 8.8 BI FT		4
2	000006		M08x20 8.8 SOCKET HEAD MACH SCREW	VIS CHC M08x20 8.8 BI FT		4
3	000008		M06x25 8.8 SOCKET HEAD MACH SCREW	VIS CHC M06x25 8.8 BI FT		4
4	110001		M04 GR. 8.8 LOCK NUT	ECROU FREIN M4 8.8 BI		4
5	120009		dD 06x14 LOCK WASHER	RONDELLE CONTACT dD 06x14 BI		4
6	120010		dD 08x18 LOCK WASHER	RONDELLE CONTACT dD 08x18 BI		4
7	190003		CLAMP	COLLIER		1
8	300025		FITTING MALE BSPP1/4-MALE JIC9/16	RACCORD MALE BSPP1/4-MALE JIC9/16		4
9	300030		ADAPTER FEMALE JIC9/16-MALE JIC7/16	REDUC. FEMELLE JIC9/16-MALE JIC7/16		1
10	300037		RUN TEE JIC 9/16 SWIVEL NUT	TE MALE JIC9/16-FEMELLE JIC9/16 TOUR.		4
11	300040		FITTING MALE BSPP3/8 MALE JIC9/16	RACCORD MALE BSPP3/8 MALE JIC9/16		1
12	300044		FITTING MALE BSPP1/2-MALE JIC9/16	RACCORD MALE BSPP1/2-MALE JIC9/16		1
13	300047		CAP BSPP 3/8	BOUCHON BSPP 3/8		1
14	300078		FITTING Male BSPP3/4-Male Ø19 GROOVE	RACCORD Male BSPP3/4-Ø19 CANNELE		1
15	300079		90° ELBOW FEM. BSPP 3/4	COUDE FEMELLE BSPP 3/4		1
16	300080		REDUCTION Male BSPT1/2-Male BSPT3/4	REDUCTION Male BSPT1/2-Male BSPT3/4		1
17	310004		OIL LEVEL INDICATOR BSPP 3/8	VOYANT DE NIVEAU BSPP 3/8		1
18	310005		BREATHER CAP BSPP 1/4	RENIFLAR BSPP 1/4		1
19	310007		OIL FILTER	FILTRE A HUILE		1
20	310013		OIL FILTER CARTRIDGE	CARTOUCHE DE FILTRE		1
21	310016		CLOGGING INDICATOR	INDICATEUR DE COLMATAGE VISUEL		1
22	310029		CHECK VALVE 4.5 BAR	CLAPET ANTI-RETOUR 4.5 BAR		1
23	310040		2-WAY GATE VALVE	VANNE 2 VOIES		2
24	DL0633		HYDRAULIC RESERVOIR	RESERVOIR HYDRAULIQUE		1
25	SE0771	SE0771	3 SPEEDS MANIFOLD ASSEMBLY	ASSEMBLAGE BLOC 3 VITESSES		1
26	ST0133		RETURN TUBE	TUYAU DE FILTRE		1

ISSUE DATE : 26/01/06

3 SPEEDS MANIFOLD ASSEMBLY

ISSUE REL :

ASSEMBLY N° : SE0771 REV :
 N° ENSEMBLE :

ASSEMBLAGE BLOC 3 VITESSES

1/1

DET REP	PART NUMBER REF.	SEE VIEW VOIR VUE	DESCRIPTION	R E V	QTY QTE
1	300001		90° ELBOW MALE BSPP 1/4-MALE JIC 9/16		1
2	300025		FITTING MALE BSPP1/4-MALE JIC9/16		2
3	300034		CAP MALE BSPP 1/4"		1
4	300040		FITTING MALE BSPP3/8 MALE JIC9/16		6
5	300047		CAP BSPP 3/8		1
6	300061		90° ELBOW MALE BSPP 3/8-MALE JIC 9/16		1
7	300067		90° ELBOW M JIC9/16 F JIC9/16 SWIVEL		8
8	520107	520107	3 SPEEDS MANIFOLD		1

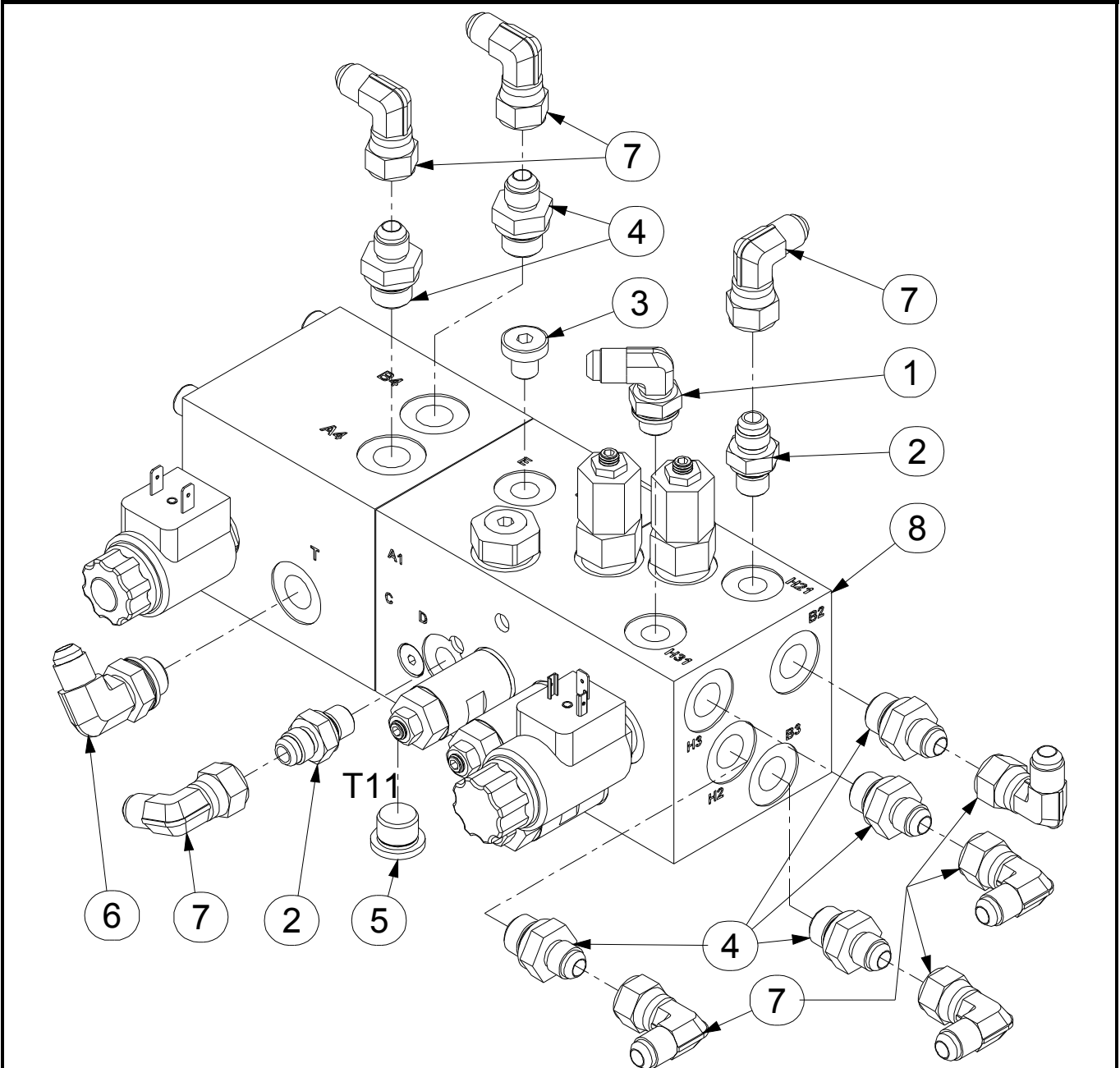

ISSUE DATE : 25/01/06

3 SPEEDS MANIFOLD

ISSUE REL :

ASSEMBLY N° : 520107 REV :
 N° ENSEMBLE :

BLOC 3 VITESSES

1/1

DET REP	PART NUMBER REF.	SEE VIEW VOIR VUE	DESCRIPTION		REV	QTY QTE
1	300034		CAP MALE BSPP 1/4"	BOUCHON MALE BSPP 1/4"		2
2	950089		PRESSURE RELIEF VALVE DB04E 250V	LIMITEUR DE PRESSION DB4E 250V		1
3	952017		2/2 CONTROL VALVE WITH CHECK VALVE	DISTRIBUTEUR A CLAPET 2/2		1
4	952067		SHUTTLE VALVE WVE-R1/4-010	SELECTEUR DE CIRCUIT WVE-R1/4-010		1
5	952082		4/2 SOLENOID VALVE	DISTRIBUTEUR A TIROIR 4/2		1
6	952083		PRESSURE RELIEF VALVE DB04E 350V	LIMITEUR DE PRESSION DB4E 350V		2
7	952084		PILOT CHECK VALVE "ERVE-R1/2-10X"	CLAPET PILOTE "ERVE-R1/2-10X"		2
8	952085		SBVE-R1/2 COUNTER BALANCE VALVE	VALVE D'EQUILIBRAGE SBVE-R1/2		2
9	952086		COIL 24DG	BOBINE 24DG		1
10	952087		COIL 24DS	BOBINE 24DS		1
11	952088		CHECK VALVE RV10A-01-C-N-05	CLAPET RV10A-01-C-N-05		1

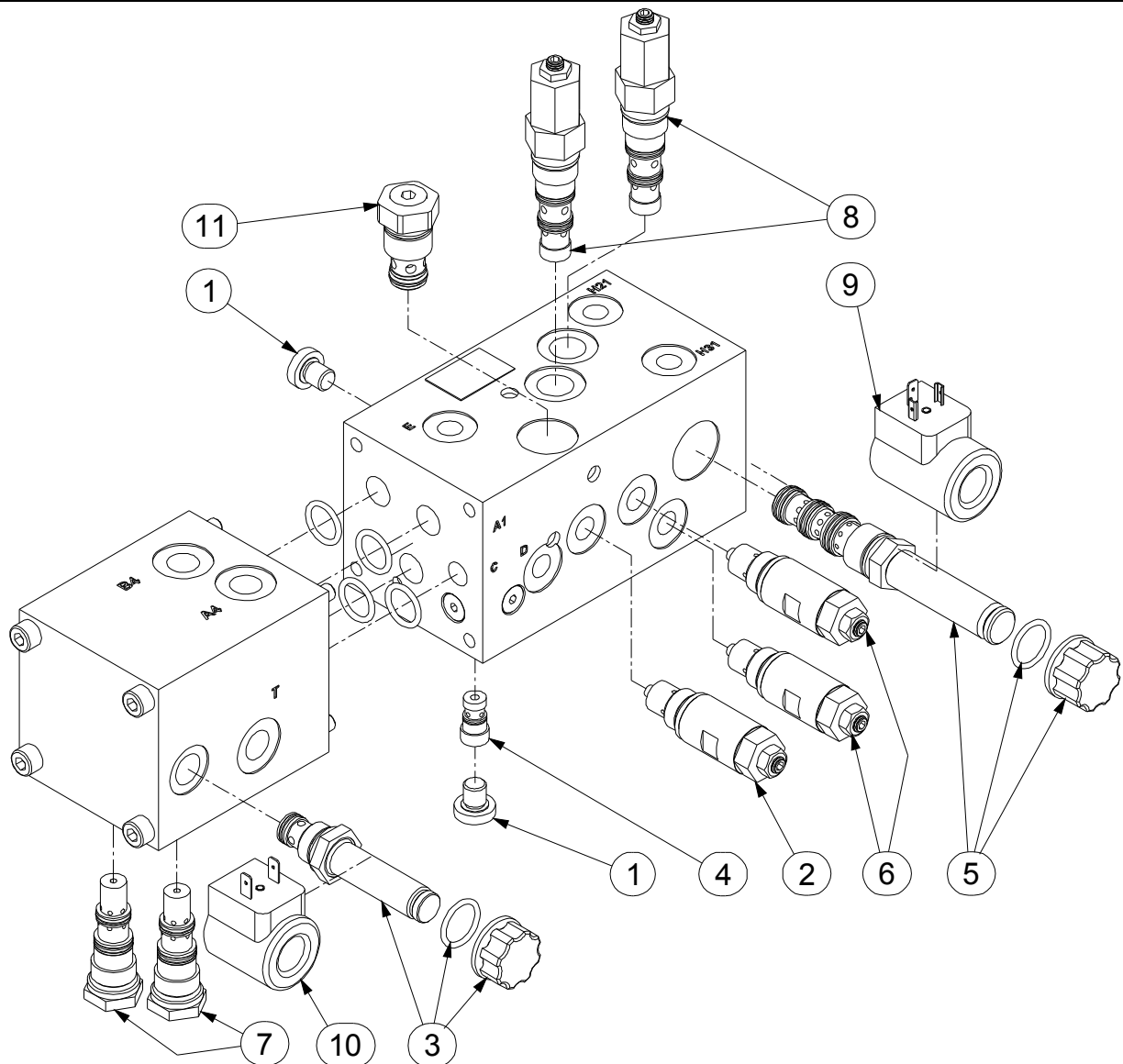

POWER UNIT INSTALL INSTALLATION DE LA CENTRALE

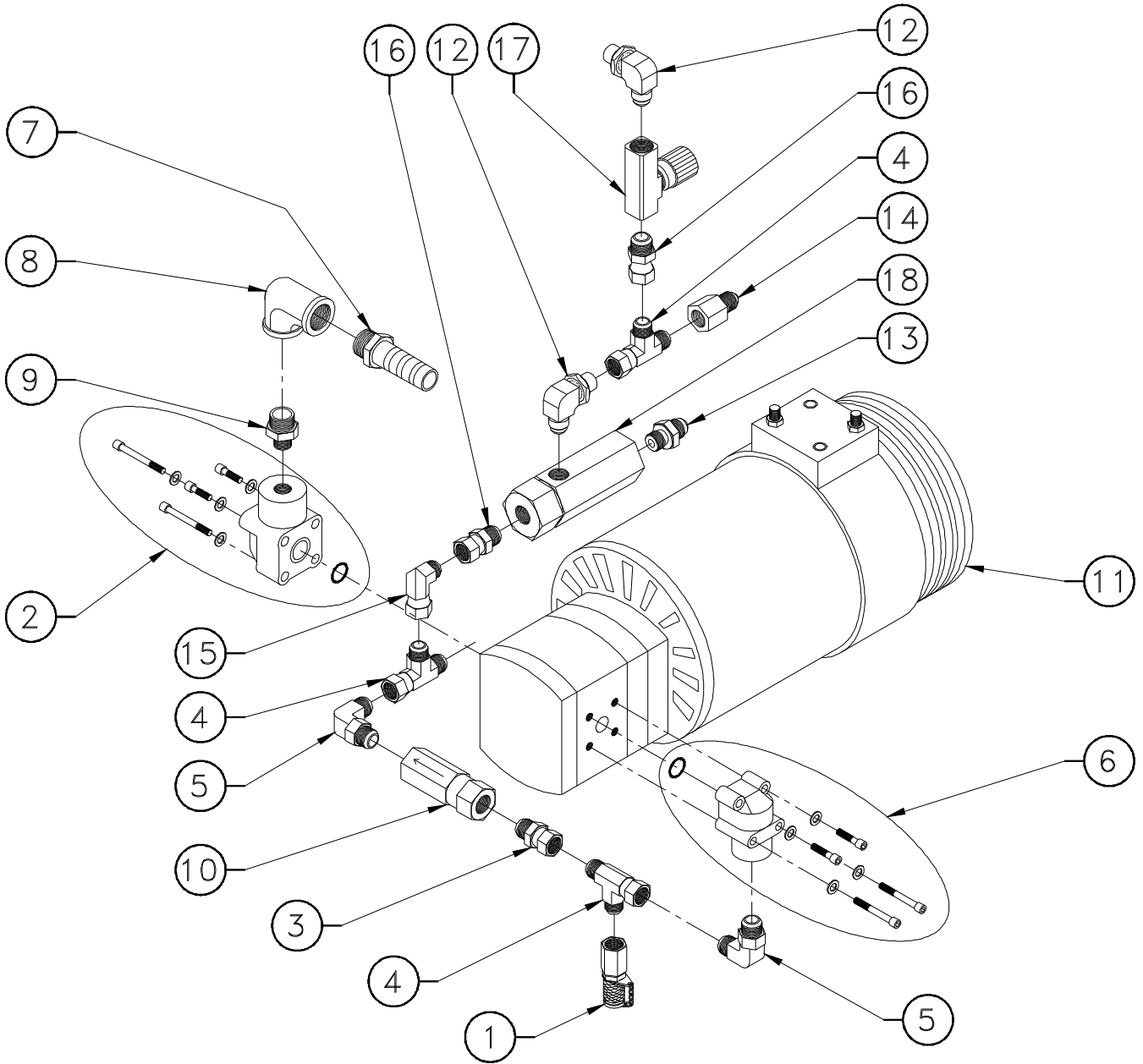

DATE : 23/12/97

5.5cc/rev POWER UNIT

MONTAGE N°/

ASSY NO : 520014 REV : A

CENTRALE 5.5cm³/t

1/1

DET NO.	REF./PART NUMBER	VOIR/ SEE VIEW	DESCRIPTION		REVISION	Qté/ Qty Req.
1	940013		DC MOTOR	MOTEUR A COURANT CONTINU		1
2	900058	900058	5.5 cc/rev PUMP	POMPE 5.5 cm ³ /t		1
3	900005		BRUSH KIT (QUANTITY : 4)	JEU DE 4 BALAIS		1
4	940032		SPRING KIT (QUANTITY : 4)	JEU DE 4 RESSORTS	A	1

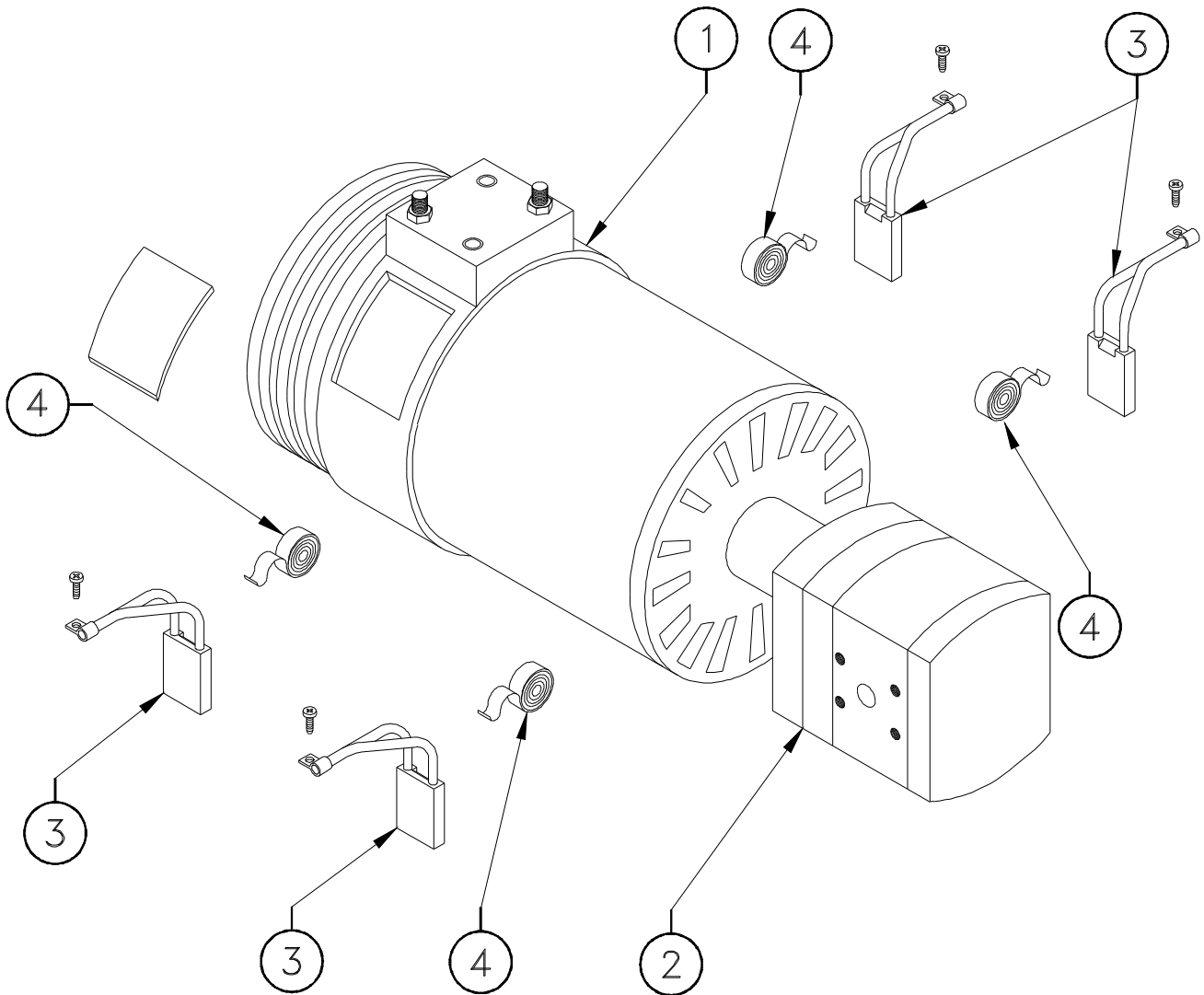

DATE : 17/03/97

5.5 cc/rev PUMP

MONTAGE N°/

ASSY NO : 900058 REV :

POMPE 5.5 cm³/tr

1/1

DET NO.	REF./PART NUMBER	VOIR/ SEE VIEW	DESCRIPTION		RE V	Qté/ Qty Req.
1	900021		SEAL KIT	KIT DE JOINTS		1
2	900045		O-RING	JOINT TORIQUE CENTRAL POMPE		1
3	940010		COUPLING	ACCOUPEMENT DE POMPE		1
4			PUMP END COVER	FLASQUE DE POMPE		1
5			PUMP END COVER	COUVERCLE DE POMPE		1
6			GEAR	PIGNON		1
7			DRIVE GEAR	PIGNON		1
8			M08x16 8.8 SPLIT CYLIND. HEAD CAPSC.	VIS CS M08x16 8.8 FP		8
9			BUSHING	PALIER		2
10			BUSHING	PALIER		2
11			5.5 cc/rev GEAR HOUSING	CORPS DE POMPE 5.5 cm ³ /rev		1
12			M10x80 8.8 SOCKET HEAD CAPSCREW	VIS CHC M10x80 8.8 BI FP		4
13			M08 WASHER	RONDELLE M08		4

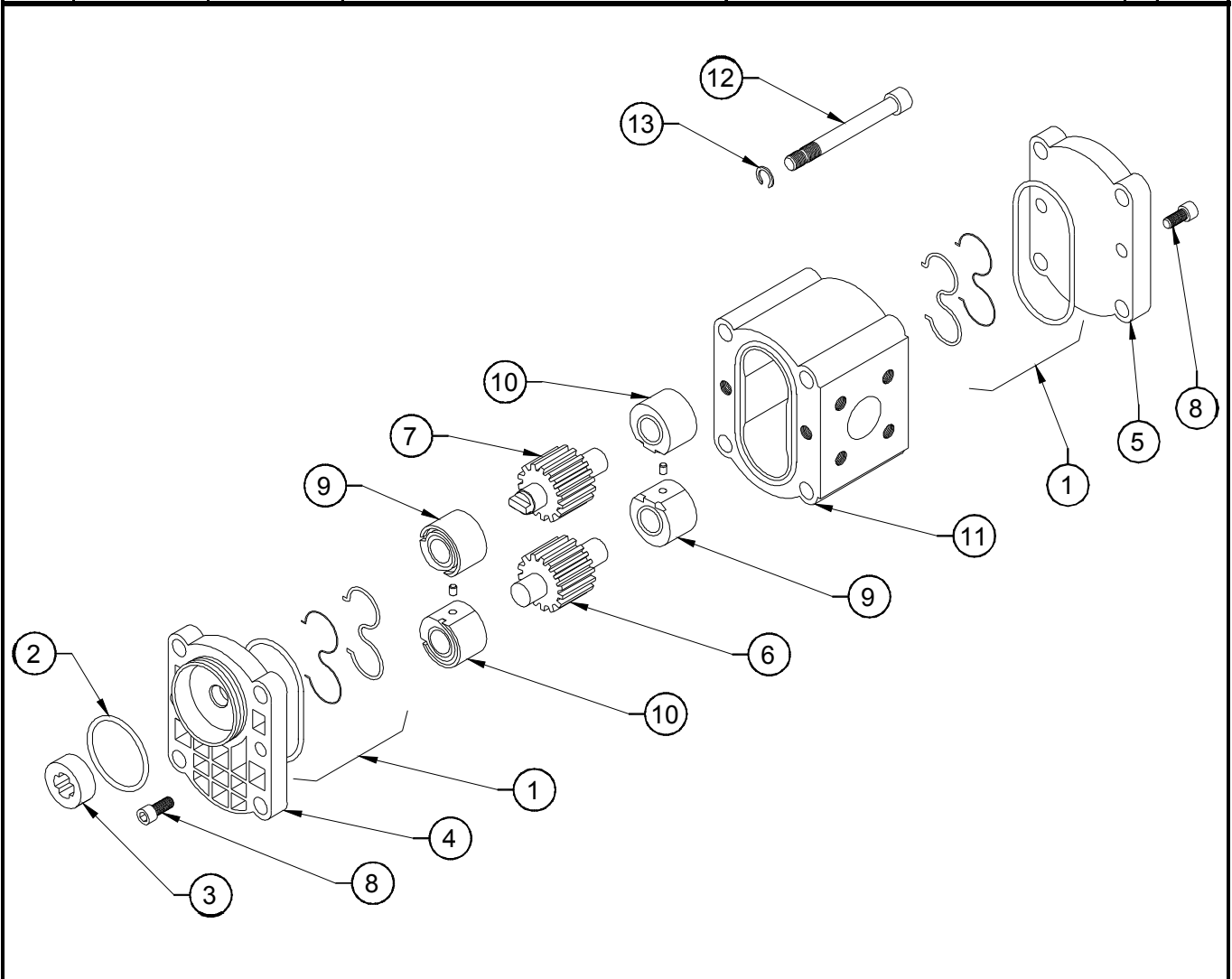

SPARE PARTS
PIECES DETACHEES

SECTION 10.

MAST 1 ASSEMBLY.
ASSEMBLAGE MAT 1.



MAST 1 ASSEMBLY ASSEMBLAGE MAT 1

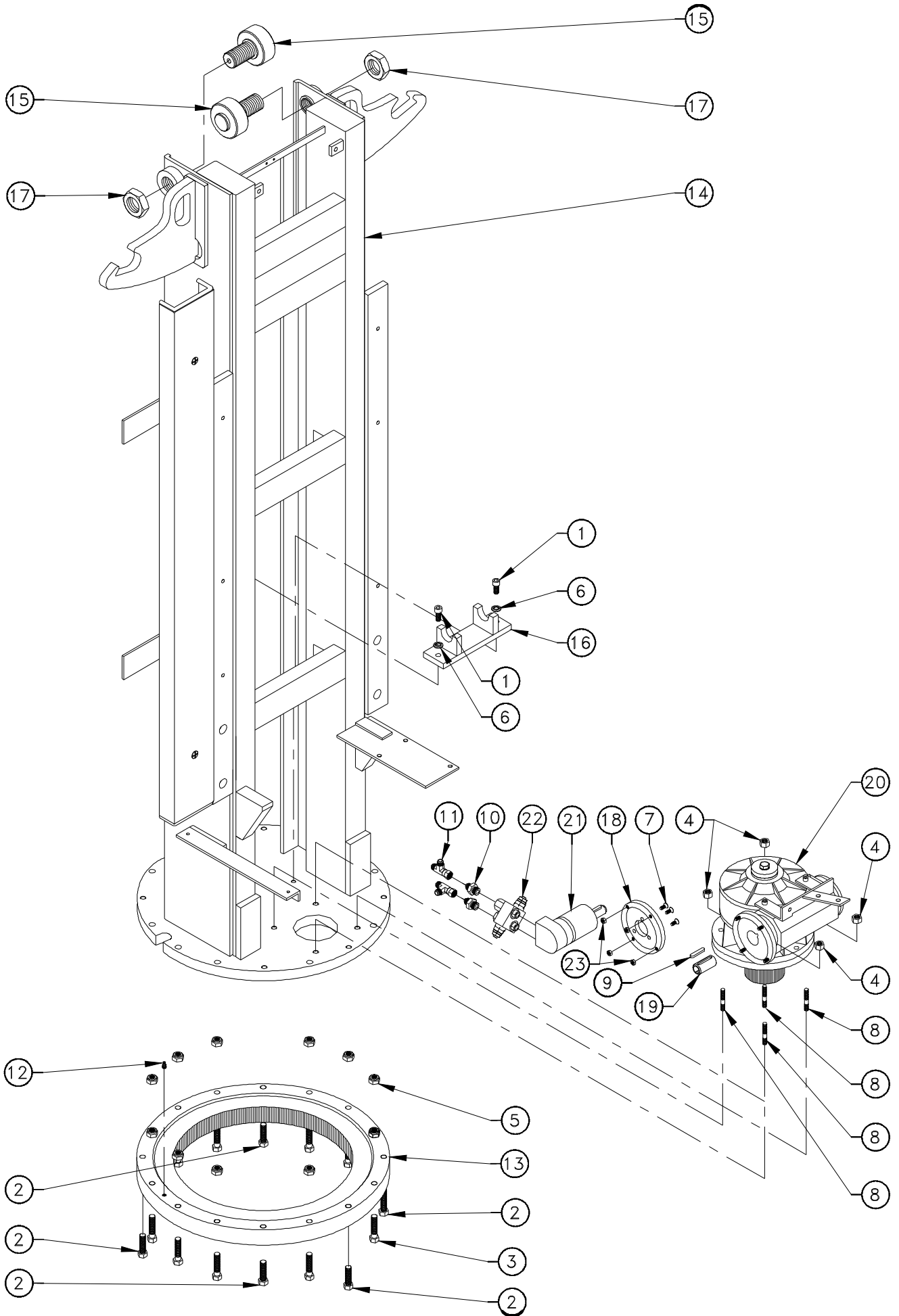

DATE : 13/03/08

MAST 1 ASSEMBLY

MONTAGE N°/
ASSY NO : SP0212 REV : C

ASSEMBLAGE MAT 1

1/1

DET NO.	REF. P/N	VOIR/ SEE VIEW	DESCRIPTION		R E V	Qté/ Qty Req.
1	000019		M10x35 8.8 SOCKET HEAD MACH SCREW	VIS CHC M10x35 8.8 BI FT		2
2	100037		M12x60 10.9 HEX HEAD CAPSCREW Black	VIS H M12x60 10.9 BR FP		5
3	100038		M12x90 10.9 HEX HEAD CAPSCREW Black	VIS H M12x90 10.9 BR FP		11
4	110014		M12 GR. 8.8 LOCK NUT	ECROU FREIN M12 8.8 BI		4
5	110017		M12 GR. 10.9 LOCK NUT	ECROU FREIN H M12 10.9 BI		11
6	120011		dD 10x22 LOCK WASHER	RONDELLE CONTACT dD 10x22 BI		2
7	130003		M06x16 10.9 COUNTERSUNK HEAD M. S.	VIS FHC M06x16 10.9 BI FT		3
8	130005		M12x35 8.8 STUD. BLACK	GOUGEON M12x35 BR 8.8		4
9	140002		A KEY 8x6x40	CLAVETTE FORME A 8x6x40		1
10	300040		FITTING MALE BSPP3/8 MALE JIC9/16	RACCORD MALE BSPP3/8 MALE JIC9/16		2
11	300037		RUN TEE JIC 9/16 SWIVEL NUT	TE MALE JIC9/16-FEMELLE JIC9/16 TOUR.		2
12	310057		GREASE FITTING 1/8 BSPT	GRAISSEUR BSPT 1/8		1
13	500002		SLEWING RING	COURONNE D'ORIENTATION		1
14	DL0389		MAST 1	MAT 1		1
15	SE0495		ROLLER ASSEMBLY	ASSEMBLAGE GALET DE GUIDAGE	C	2
16	ST0772		MAST CYLINDER SUPPORT	SUPPORT VERIN DE LEVAGE		1
17	US0026		M36 GR. 8.8 HEX NUT	ECROU M36 8.8		2
18	US0044		MOTOR ADAPTOR FLANGE	FLASQUE MOTEUR		1
19	US0045		COUPLING	ACCOUPLLEMENT		1
20		SP1105	SLEWING DRIVE ASSEMBLY	ASSEMBLAGE REDUCT. D'ORIENTATION		1
21		APPENDIX E	SWING MOTOR	MOTEUR D'ORIENTATION		1
22	310084		DOUBLE RELIEF VALVE MANIFOLD	BLOC LIMITEUR DOUBLE	B	1
23	110015		M06 GR. 8.8 HEX NUT	ECROU H M06 8.8 BI	A	4

SWING DRIVE ASSEMBLY ASSEMBLAGE MOTO-REDUCTEUR D'ORIENTATION

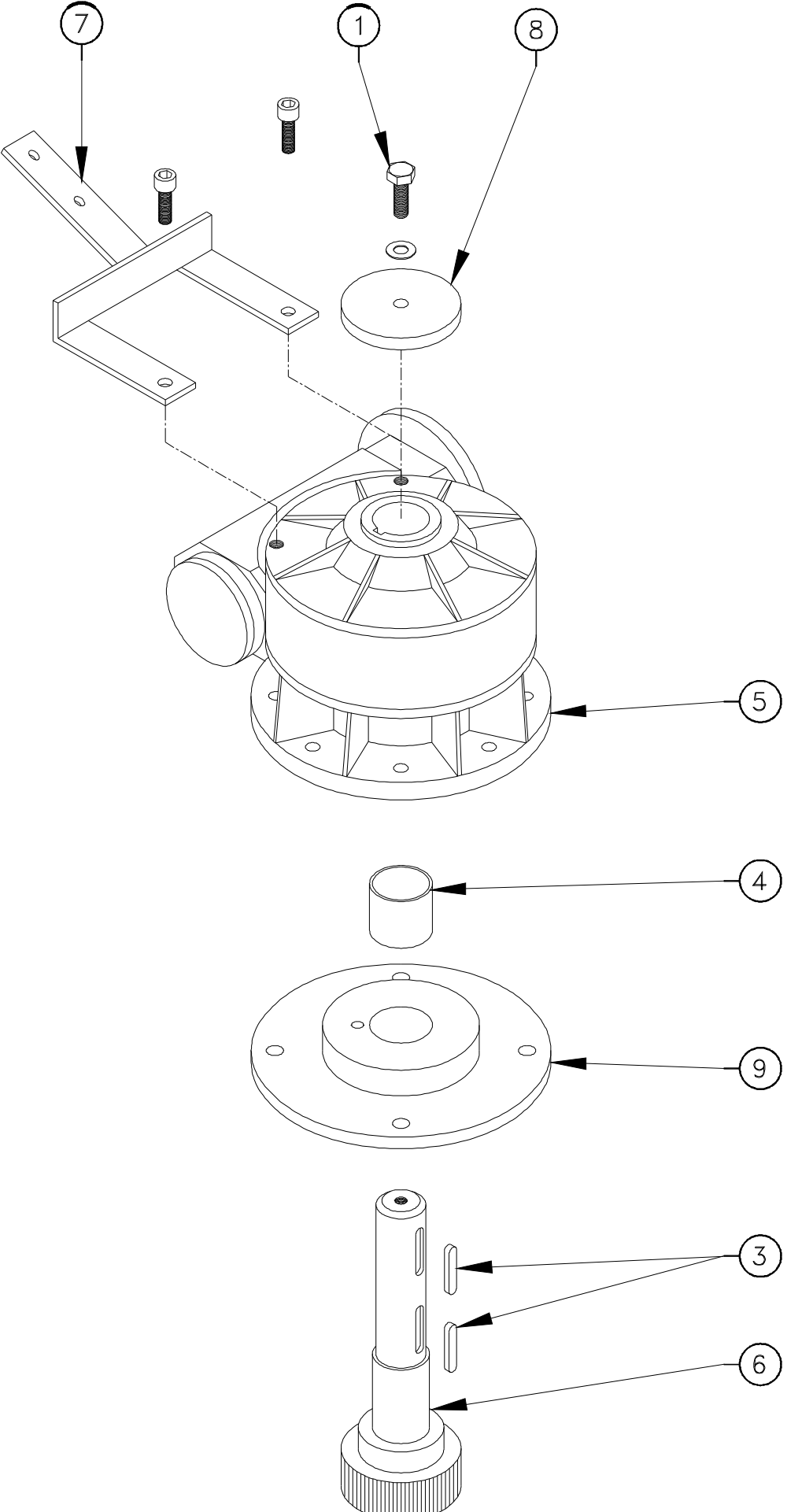

SPARE PARTS
PIECES DETACHEES

SECTION 11

JIB INSTALL
INSTALLATION BRAS



JIB INSTALL INSTALLATION BRAS

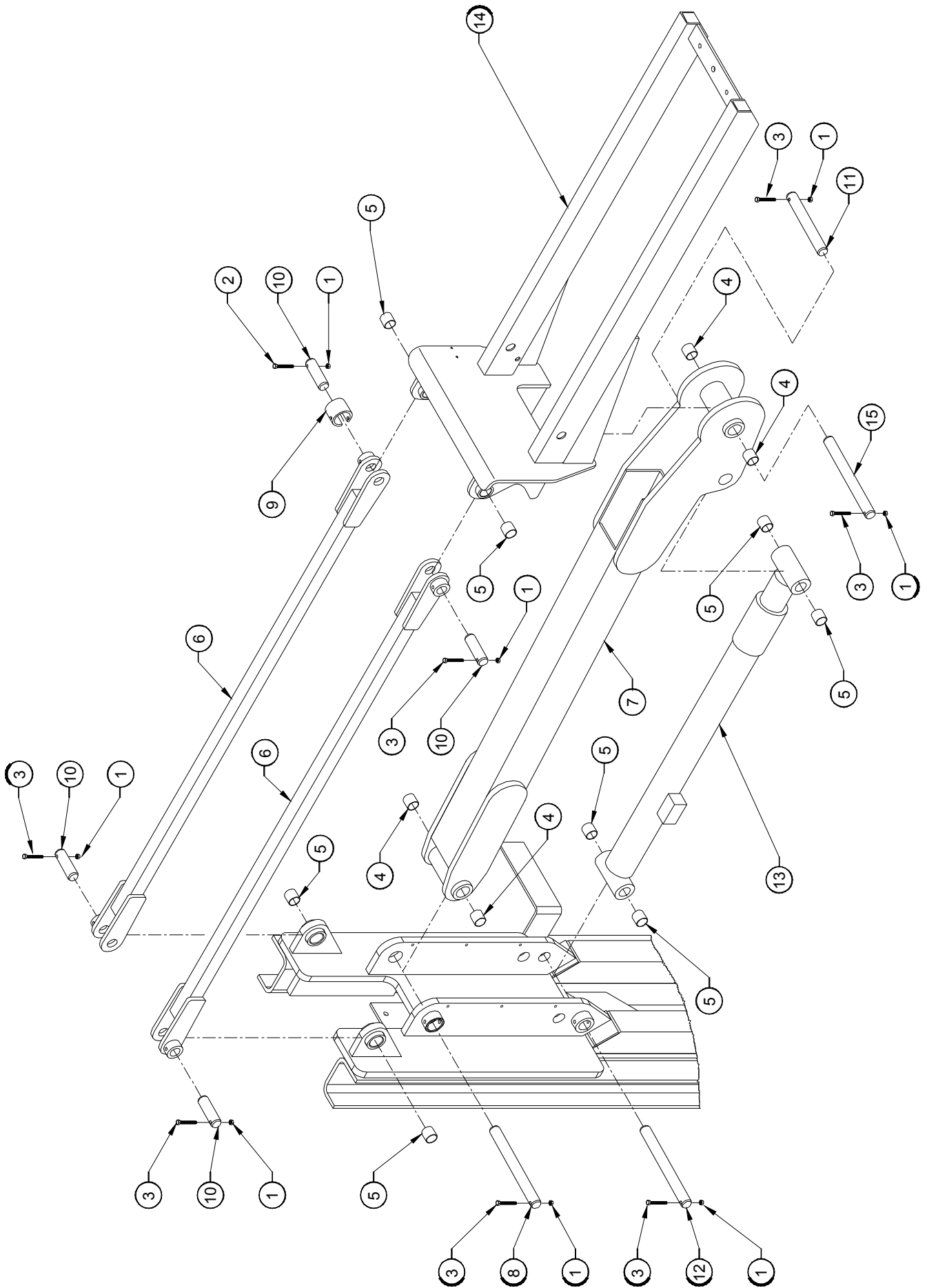

SPARE PARTS ***PIECES DETACHEES***

APPENDIX-ANNEXES

- A-** CYLINDERS
VERINS

- B-** CHAIN SLACK SWITCHES INSTALL
INSTALLATION CAPTEURS DE CHAINE

- C-** UPPER CONTROL VALVE INSTALL
INSTALLATION DISTRIBUTEUR HAUT

- D-** TIRE AND WHEEL INSTALL
INSTALLATION DES ROUES

- E-** HYDRAULIC MOTORS INSTALL
INSTALLATION DES MOTEURS

- F-** BATTERY AND CHARGER INSTALL
INSTALLATION BATTERIE ET CHARGEUR

- G-** DECALS INSTALL
INSTALLATION DES AUTOCOLLANTS

- H-** PLATFORM INSTALL
INSTALLATION DU PANIER



SPARE PARTS
PIECES DETACHEES

SECTION A.

CYLINDERS.
VERINS.

DATE : 19/06/02

MAST CYLINDER

MONTAGE N°/

ASSY NO : RM0084 REV :

VERIN DE MAT

1/1

To order check mark on marking zone and indicate machine serial number.

Pour commander vérifier la marque sur la zone de marquage et indiquer le numéro de série de la machine.

MARK MARQUE	DET. NO. 1	CYLINDERS PART NUMBER REFERENCE VERINS	DET. NO. 2	SEAL KIT ITEM REFERENCE KIT DE JOINT	REV
V 99/32 (Year/Week - An/Sem)		ST0323		900123	
EUROMAT 15/99 ST1394		ST1394		900085	
SAHL 15/99 ST1754		ST1754		960072	

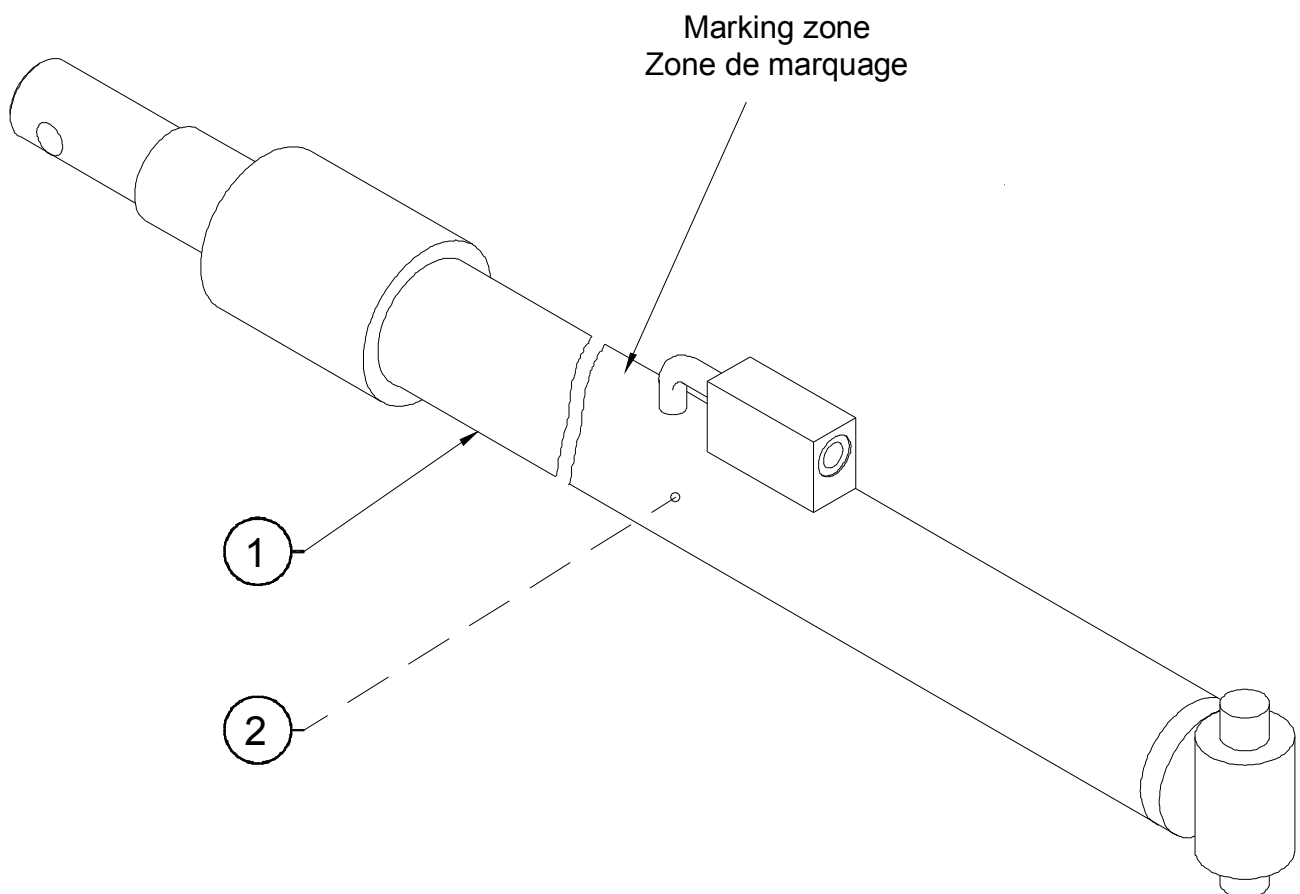

DATE : 19/06/02

JIB CYLINDER

MONTAGE N°/
ASSY NO : RM0085 REV :

VERIN DE BRAS

1/1

To order check mark on marking zone and indicate machine serial number.
Pour commander vérifier la marque sur la zone de marquage et indiquer le numéro de série de la machine.

MARK MARQUE	DET. NO. 1	CYLINDERS PART NUMBER REFERENCE VERINS	DET. NO. 2	SEAL KIT ITEM REFERENCE KIT DE JOINT	REV
V 99/32 (Year/Week - An/Sem)		ST0324		900123	
EUROMAT 15/99 ST1393		ST1393		900085	
SAHL 15/99 ST1753		ST1753		960072	

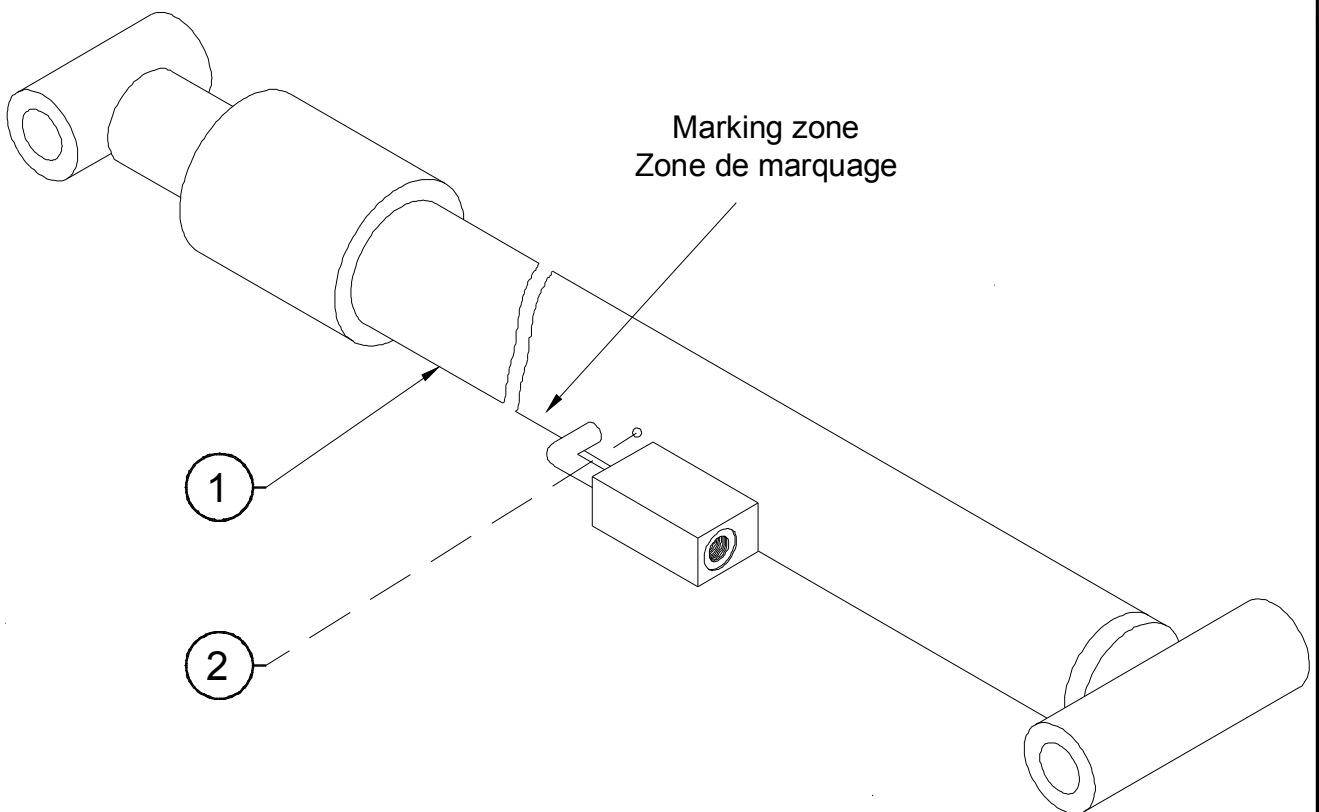

DATE : 03/02/98

STEER CYLINDER

MONTAGE N°/
ASSY NO : ST0177 REV :

VERIN DE DIRECTION

1/1

DET NO.	REF./PART NUMBER	VOIR/ SEE VIEW	DESCRIPTION		REV	Qté/ Qty Req.
1	ST0177		STEER CYLINDER	VERIN DE DIRECTION		1
2	900124		SEAL KIT	KIT DE JOINTS		1

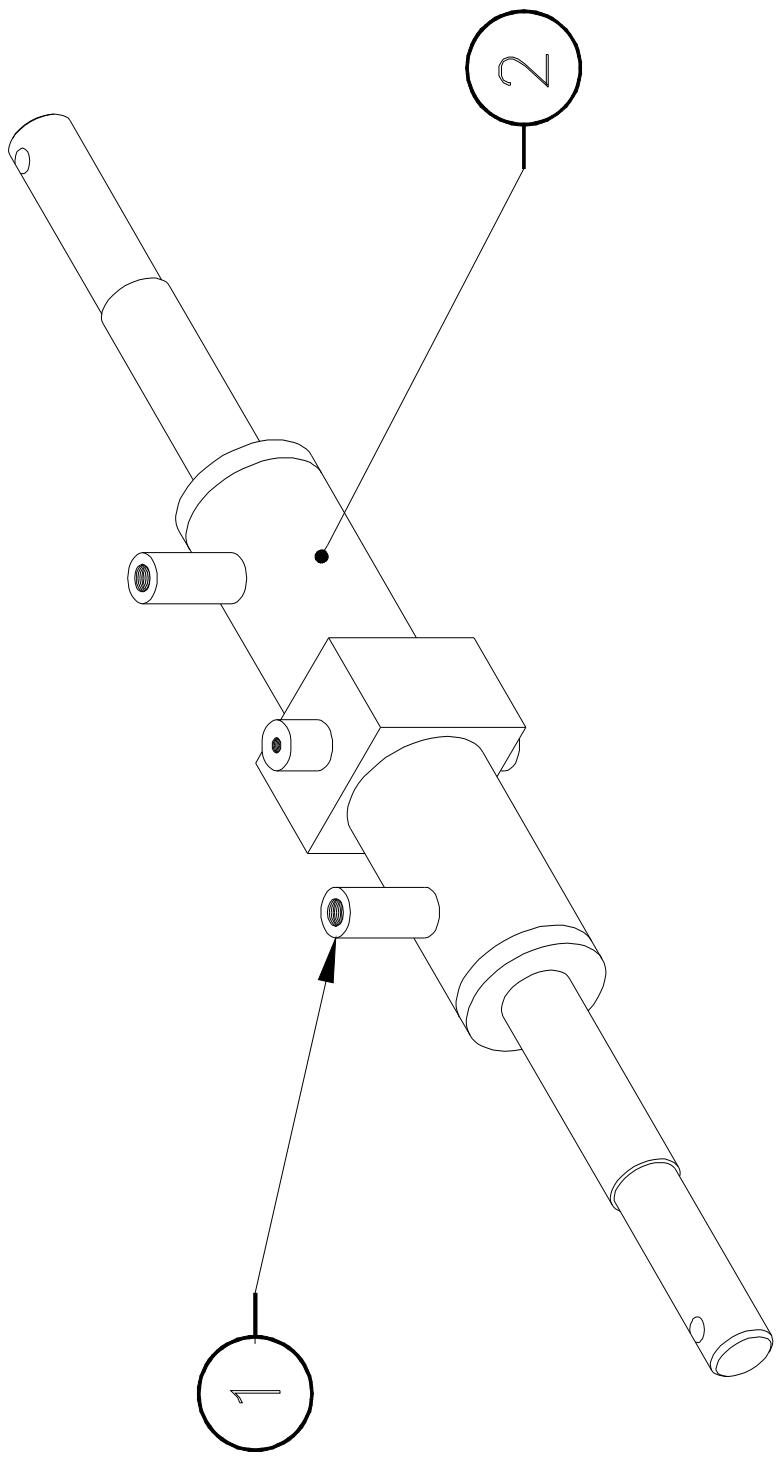

A

ST0177

A

DATE : 22/01/98

BRAKE CYLINDER

MONTAGE N°/

ASSY NO : SD0048 REV :

VERIN FREIN

1/1

DET NO.	REF./PART NUMBER	VOIR/ SEE VIEW	DESCRIPTION		R E V	Qté/ Qty Req.
1	160005		BRAKE CYLINDER SPRING	RESSORT VERIN FREIN		1
2	900010		BRAKE CYLINDER SEAL KIT	KIT DE JOINTS VERIN FREIN		1
3	930057		CYLINDER BARREL	CORPS VERIN FREIN		1
4	930058		CYLINDER ROD	TIGE DE VERIN		1
5	930070		CYLINDER PISTON	PISTON		1
6	930071		CYLINDER HEAD	TETE DE VERIN		1
7	SD0048		BRAKE CYLINDER	VERIN FREIN		2

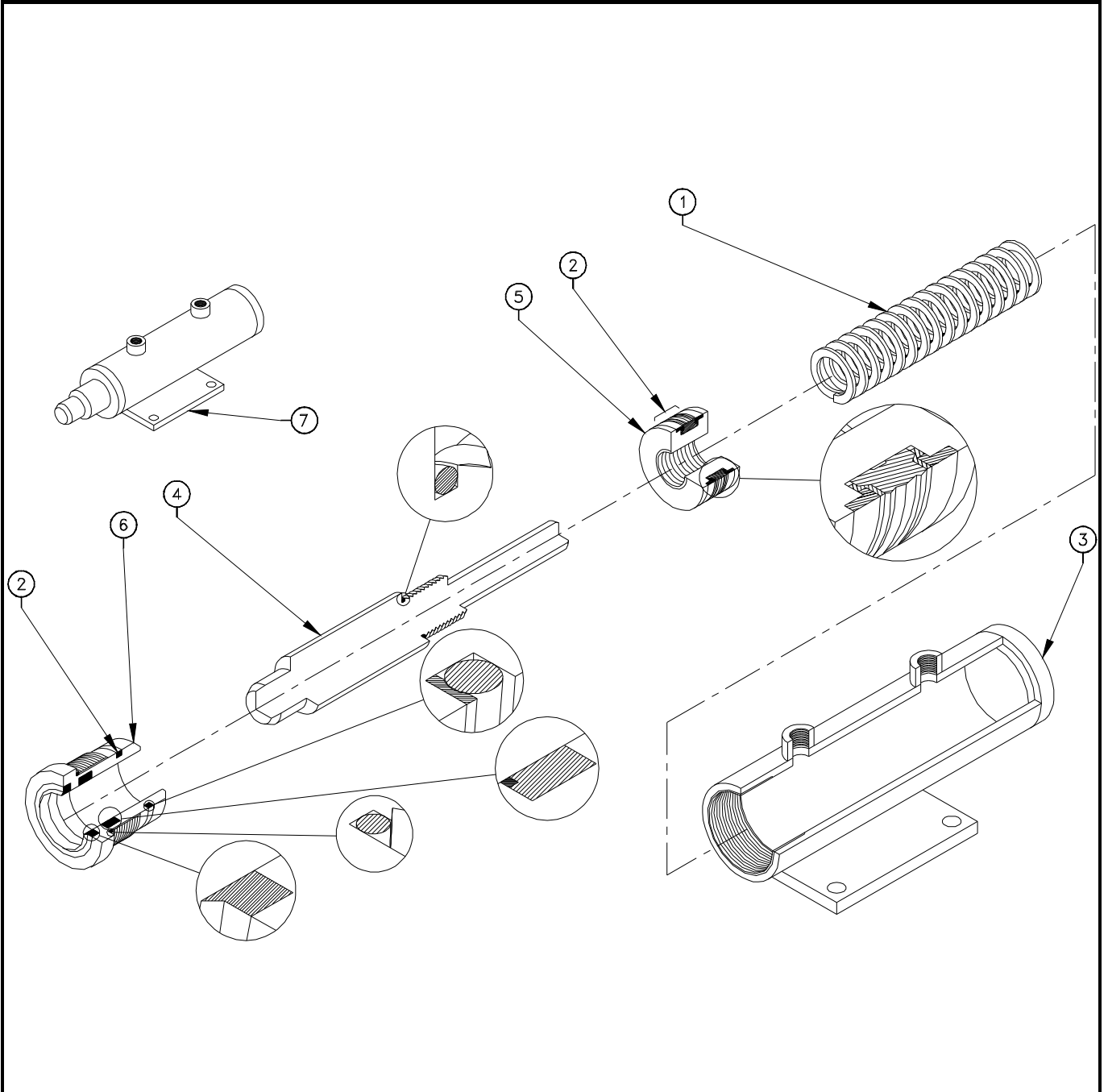

A

SD0048

A

SPARE PARTS
PIECES DETACHEES

SECTION B.

SINGLE SWITCH BY CHAIN STAGE.
1 CAPTEUR PAR ETAGE DE CHAINE.

SINGLE SWITCH BY CHAIN STAGE 1 CAPTEUR PAR ETAGE DE CHAINE

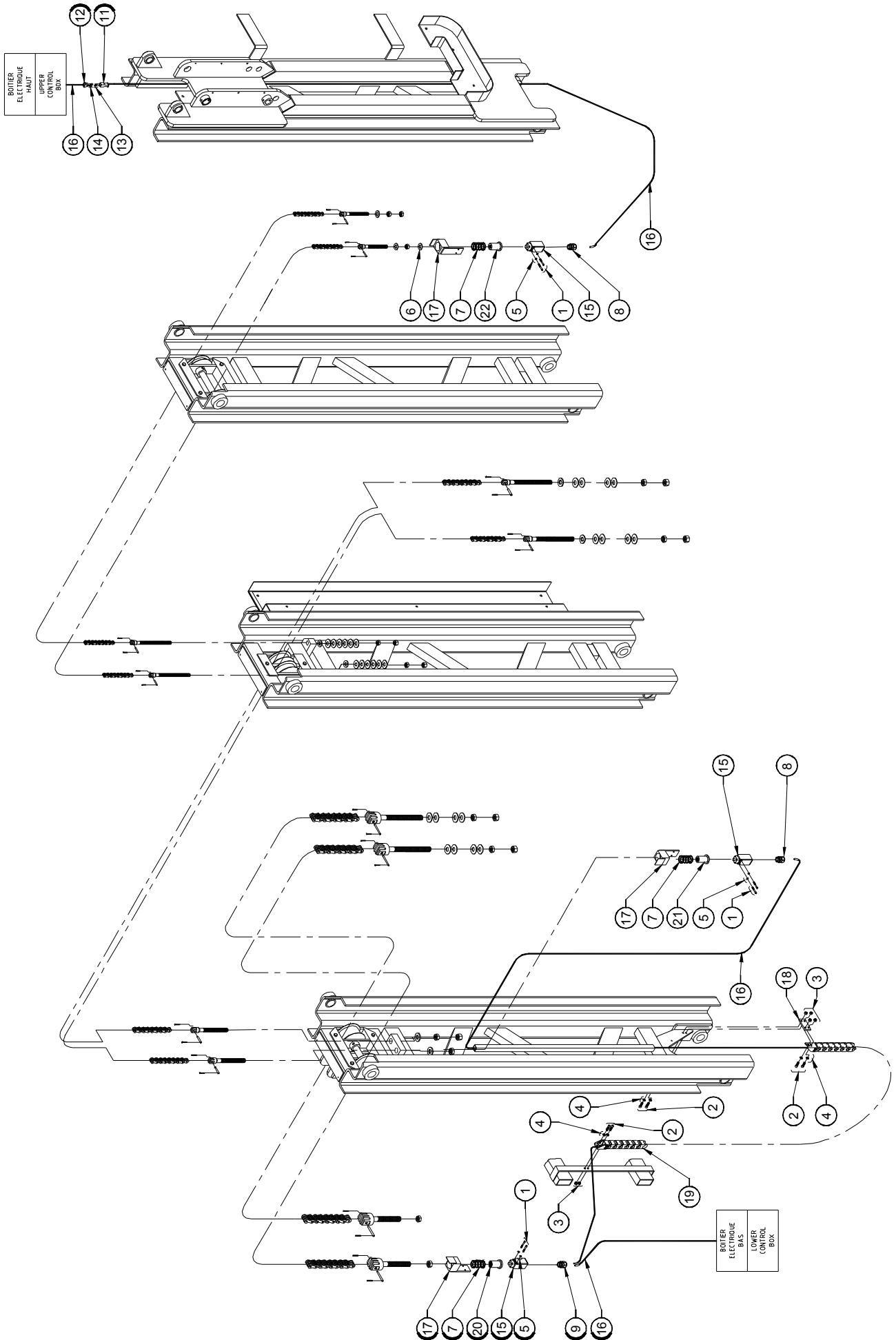

SPARE PARTS
PIECES DETACHEES

SECTION C.

UPPER VALVE ASSEMBLY FOR CE.
ASSEMBLAGE DISTRIBUTEUR HAUT CE.

DATE : 19/01/98

UPPER VALVE ASSEMBLY FOR CE

MONTAGE N°/

ASSY NO : SP0235 REV :

ASSEMBLAGE DISTRIBUTEUR HAUT CE

1/1

DET NO.	REF./PART NUMBER	VOIR/ SEE VIEW	DESCRIPTION		R E V	Qté/ Qty Req.
1	300037		RUN TEE JIC 9/16 SWIVEL NUT	TE MALE JIC9/16-FEMELLE JIC9/16 TOUR.		1
2	300040		FITTING MALE BSPP3/8 MALE JIC9/16	RACCORD MALE BSPP3/8 MALE JIC9/16		13
3	320018		VALVE	DISTRIBUTEUR		1
4	520035	520035	PILOT BLOCK	BLOC PILOTAGE		1
5	900081		VALVE HANDLE WITH NUT	LEVIER AVEC ECROU		5
6	300034		CAP MALE BSPP 1/4"	BOUCHON MALE BSPP 1/4"		1

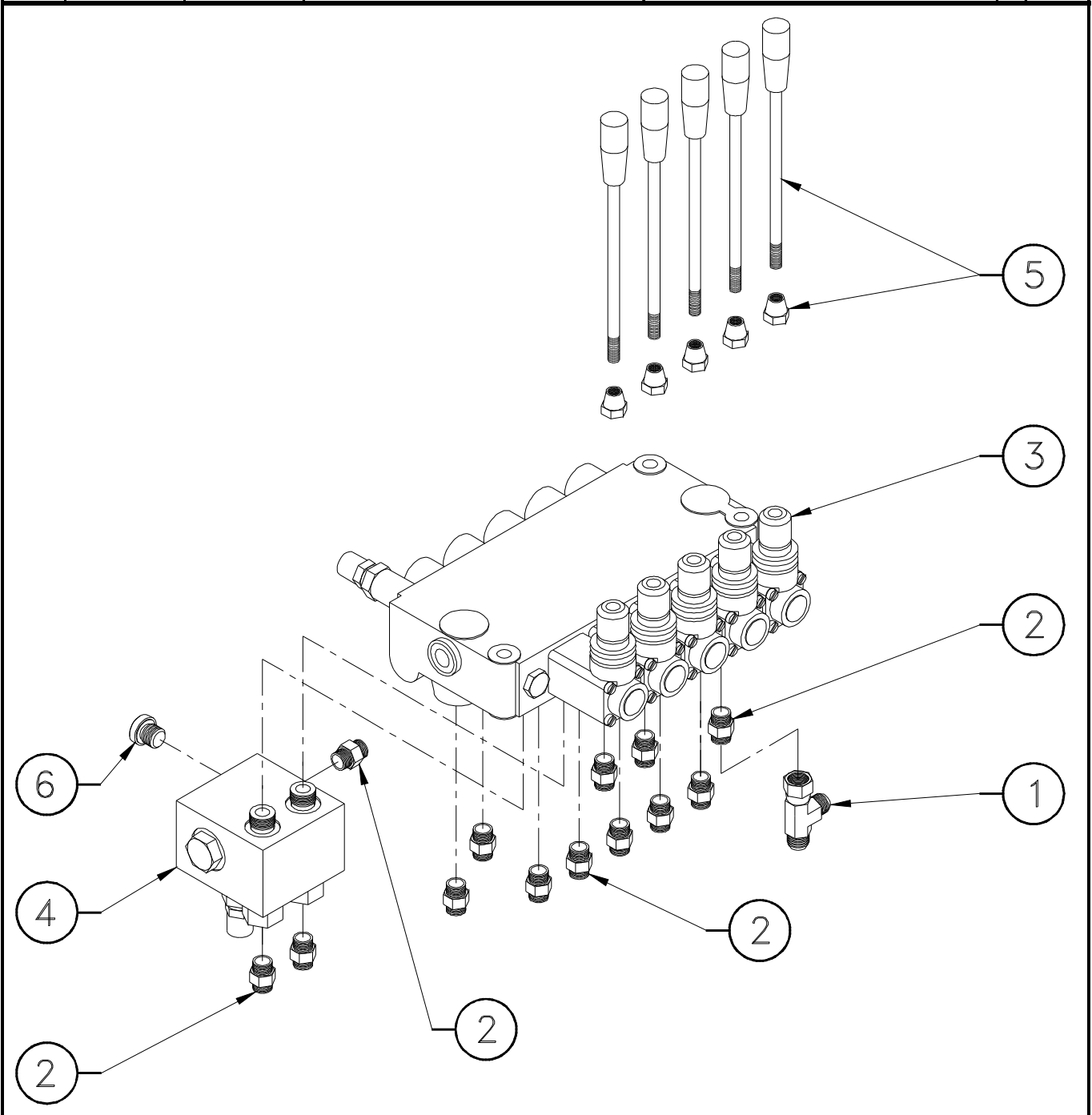

C

SP0235

C

DATE : 24/01/05

PILOT BLOCK

MONTAGE N°/
 ASSY NO : 520035 REV : A

BLOC PILOTAGE

1/1

DET NO.	REF./PART NUMBER	VOIR/ SEE VIEW	DESCRIPTION		R E V	Qté/ Qty Req.
1	900068		SHUTTLE VALVE	SELECTEUR DE CIRCUIT		1
2	900072		SEAL KIT	KIT DE JOINTS		1
3			NOT REQUIRED	NON REQUIS	A	1
4	952075		PRESSURE RELIEF VALVE	LIMITEUR DE PRESSION	A	1
5	920013		BANJO VALVE	CLAPET BANJO		2
6	920014		SEAL KIT	KIT DE JOINTS		2
7	920015		MANIFOLD	BLOC FORE		1

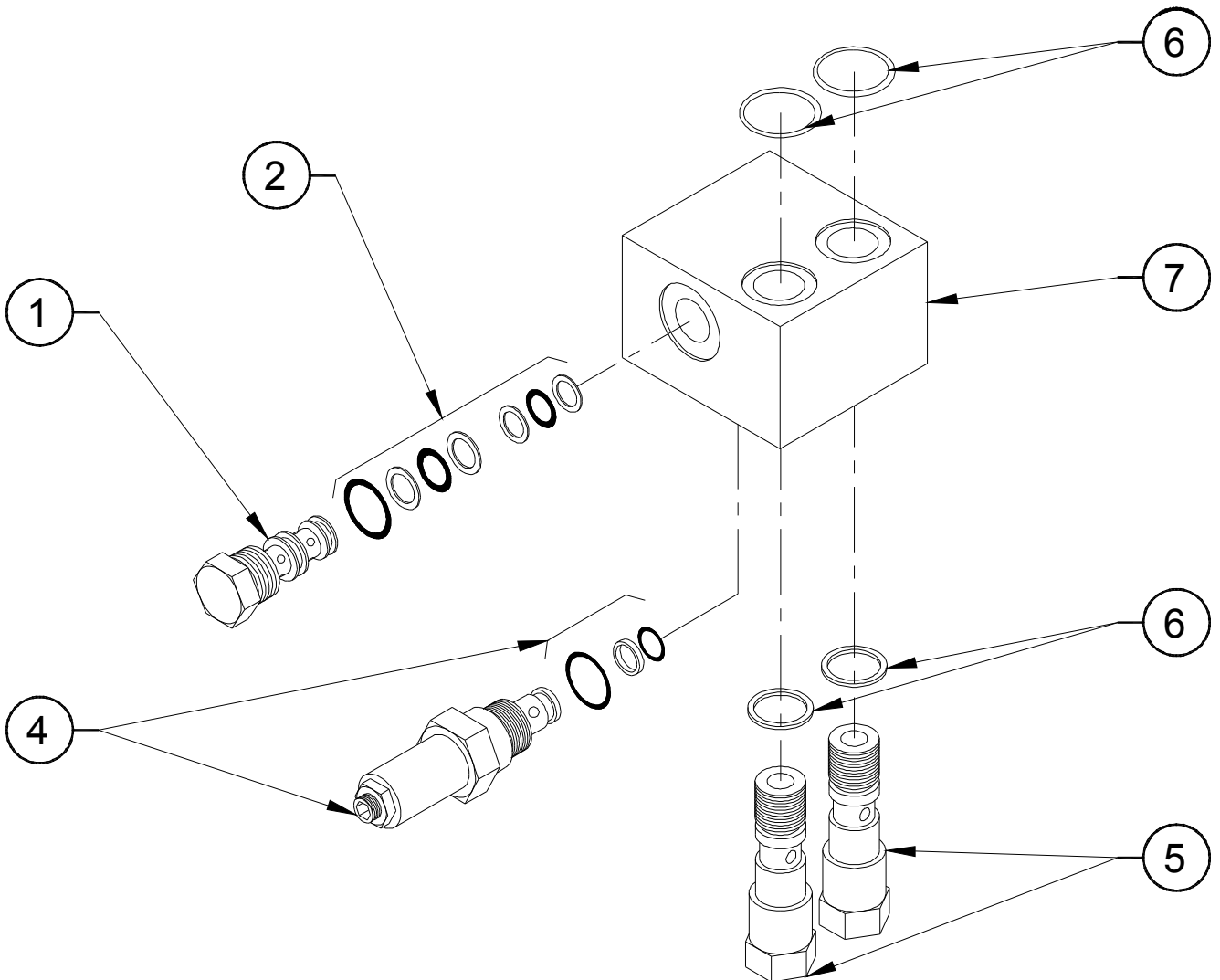

SPARE PARTS
PIECES DETACHEES

SECTION D.

TIRE AND WHEEL INSTALL.
INSTALLATION DES ROUES.

DATE : 22/01/98

TYRE & WHEEL STANDARD

MONTAGE N°/

ASSY NO : SP0201 REV :

ROUES STANDARD

1/1

DET NO.	REF./PART NUMBER	VOIR/ SEE VIEW	DESCRIPTION		REV	Qté/ Qty Req.
1	DL0270		DRIVE & BRAKE WHEELS	ROUES MOYEU FREIN		2
2	ST0650		STEERING WHEELS	ROUES DIRECTRICES		2

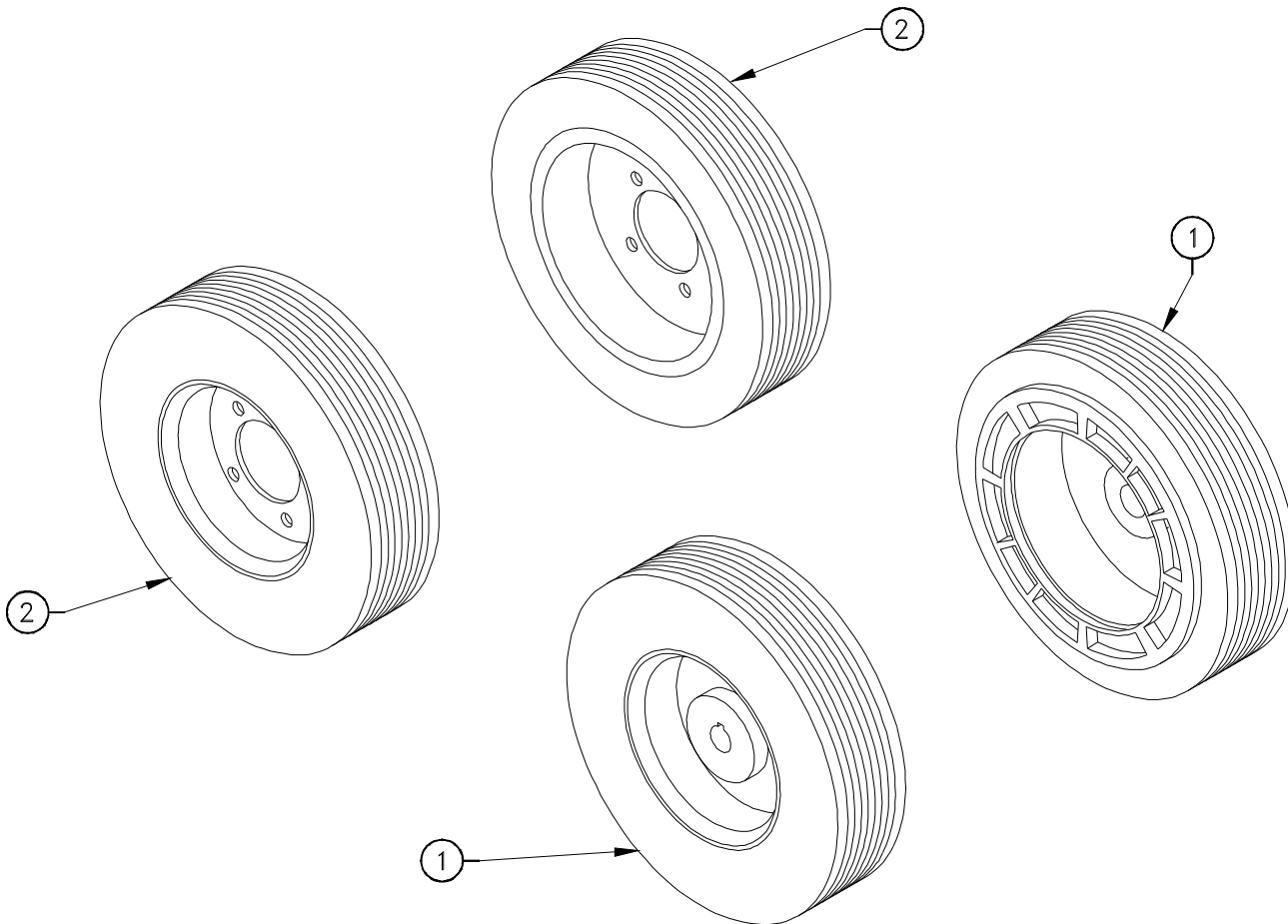

DATE : 11/12/06

TYRE & WHEEL NON MARKING

MONTAGE N°/

ASSY NO : SP0200 REV :

ROUES NON MARQUANTES

1/1

DET NO.	REF./PART NUMBER	VOIR/ SEE VIEW	DESCRIPTION		REV	Qté/ Qty Req.
1	DL0277		WHITE DRIVE & BRAKE WHEEL	ROUE MOYEU FREIN BLANCHE		2
1	DL0800		GREY DRIVE & BRAKE WHEEL	ROUE MOYEU FREIN GRISE		2
2	ST0701		WHITE NON MARKING STEERING WHEEL	ROUE DIR. NON MARQUANTE BLANCHE		2
2	ST3078		GREY NON MARKING STEERING WHEEL	ROUE DIR. NON MARQUANTE GRISE		2
3	130022		STATIC STRAP	TRESSE DE MASSE		1

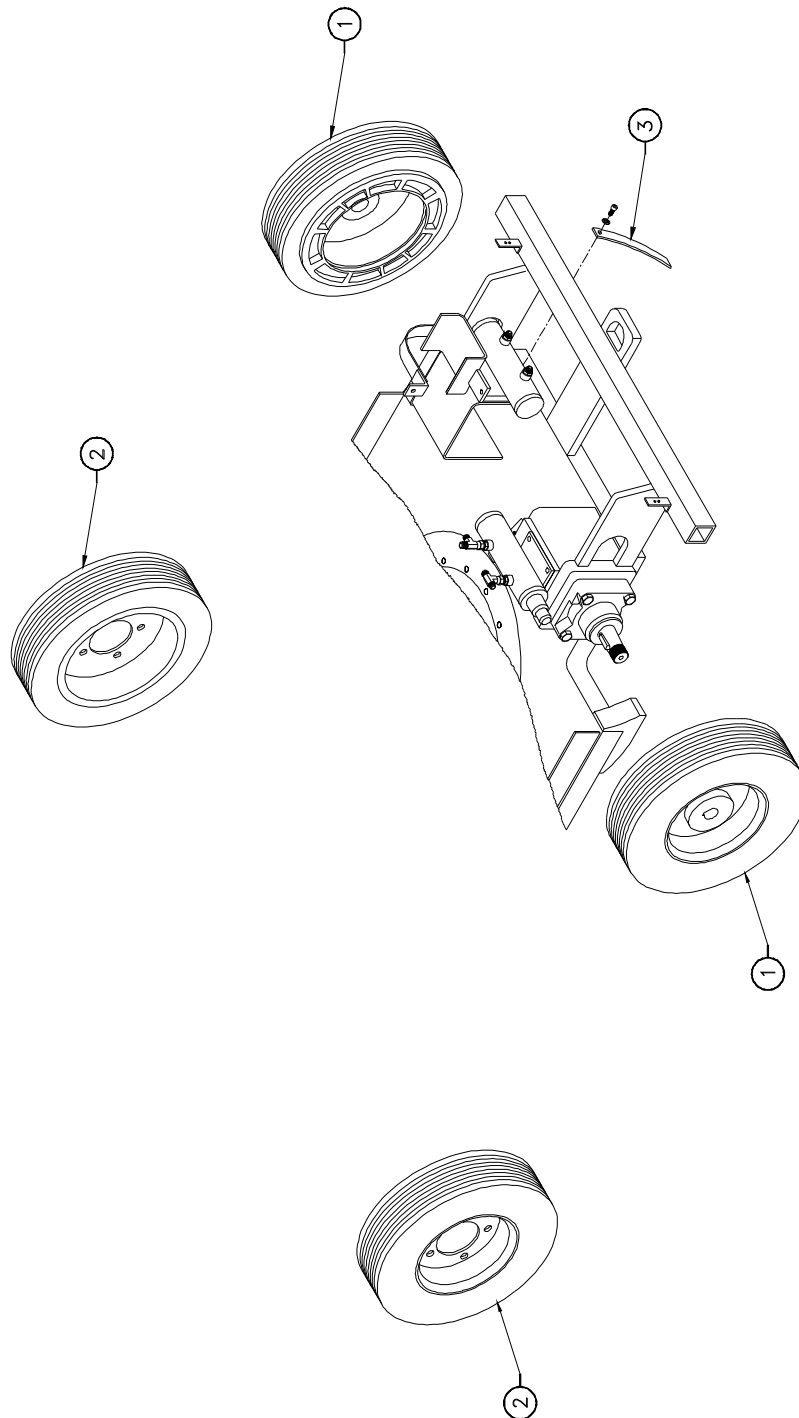

SPARE PARTS
PIECES DETACHEES

SECTION E.

**SWING MOTOR AND HYDRAULIC MOTORS
INSTALL.**

**INSTALLATION DU MOTEUR D'ORIENTATION
ET DES MOTEURS DE ROUES.**

SWING MOTOR 32cc/rev MOTEUR D'ORIENTATION 32cm³/t

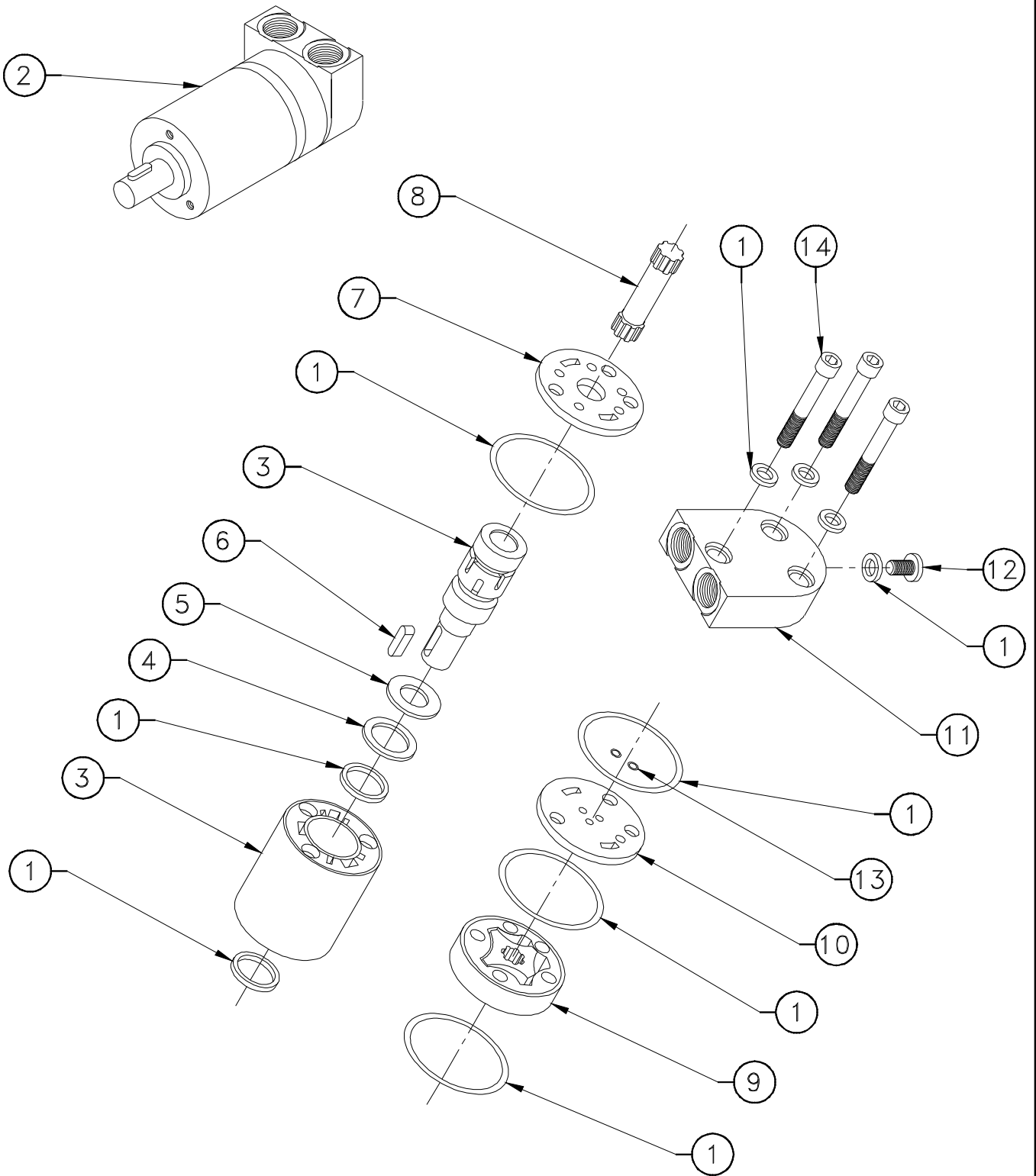

DATE : 22/01/98

SWING MOTOR 32cc/rev

MONTAGE N°/

ASSY NO : 320006 REV :

MOTEUR D'ORIENTATION 32cm³/t

1/1

DET NO.	REF./PART NUMBER	VOIR/ SEE VIEW	DESCRIPTION		RE V	Qté/ Qty Req.
1	900043		SEAL KIT	KIT DE JOINTS		1
2	320006		SWING MOTOR 32cc/rev	MOTEUR D'ORIENTATION 32cm³/t		1
3			HOUSING + OUTPUT SHAFT	CORPS DE MOTEUR		1
4			BEARING RACE	CHEMIN DE ROULEMENT		1
5			AXIAL NEEDLE BEARING	BUTEE A AIGUILLE		1
6	950006		KEY SWING MOTOR	CLAVETTE MOTEUR		1
7			DISTRIBUTOR PLATE	GLACE DE DISTRIBUTION		1
8			CARDAN SHAFT	AXE CARDAN		1
9			GEARWHEEL SET	ENGRENAGES		1
10			INTERMEDIAIRE PLATE	GLACE INTERMEDIAIRE		1
11			END COVER	COUVERCLE		1
12			DRAIN PLUG	BOUCHON		1
13			CHECK VALVE BALL	JOINTS		1
14			M08-55 8.8 SOCK. HEAD CAPSCREW	VIS CHC M08-55 8.8		1

HYDRAULIC MOTOR MB240

MOTEUR HYDRAULIQUE MB240

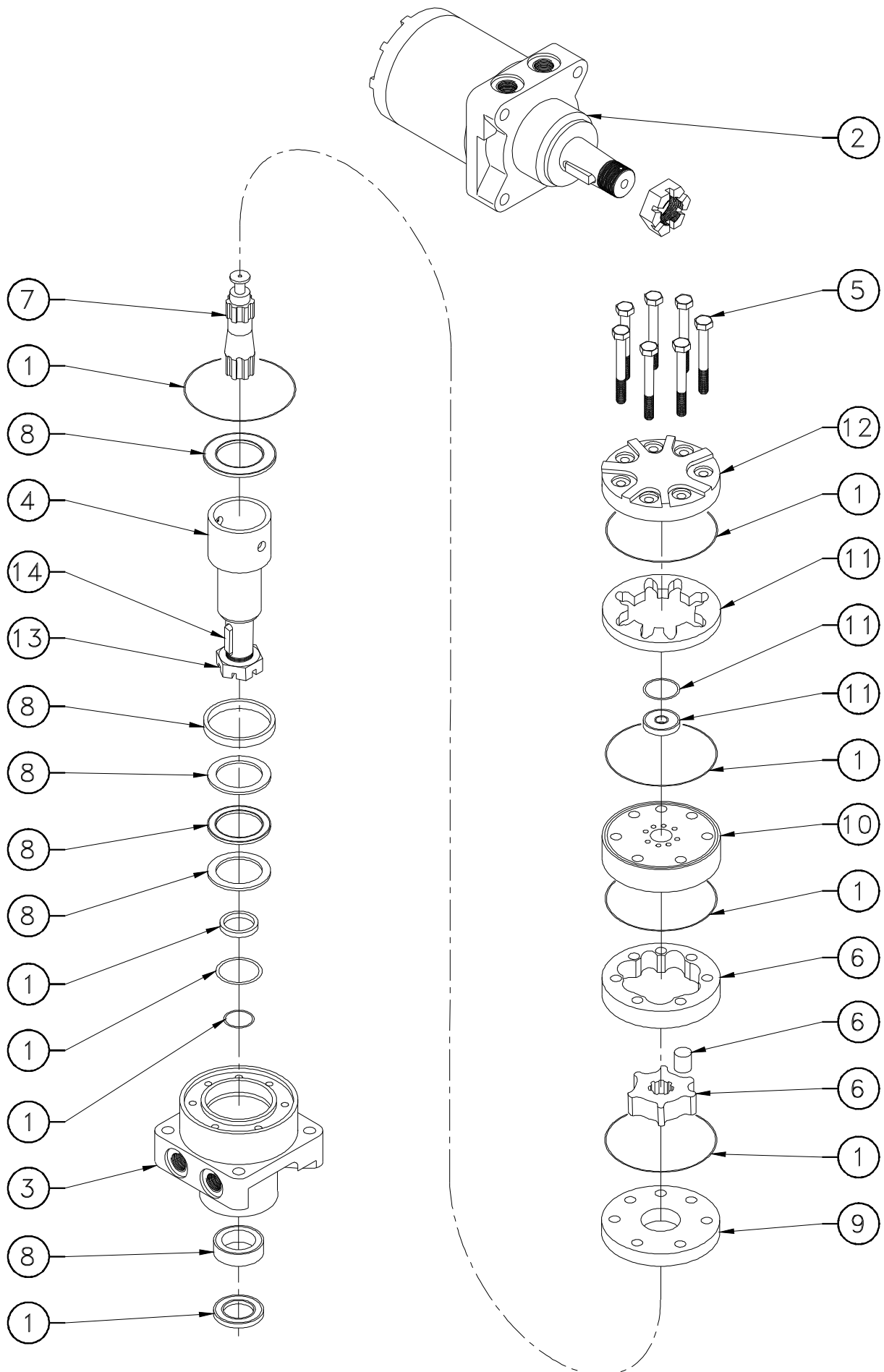

DATE : 22/01/98

HYDRAULIC MOTOR MB240

MONTAGE N°/

ASSY NO : 320024 REV :

MOTEUR HYDRAULIQUE MB240

1/1

DET NO.	REF./PART NUMBER	VOIR/ SEE VIEW	DESCRIPTION		REV	Qté/
						Qty Req.
1	900022		SEAL KIT	KIT DE JOINTS		1
2	320024		HYDRAULIC MOTOR MB240	MOTEUR HYDRAULIQUE MB240		1
3	932006		HOUSING	FLASQUE MOTEUR		1
4	932007		COUPLING SHAFT	ARBRE DE ROUE		1
5	932008		SPECIAL SCREW	VIS		1
6	932009		ROTOR SET	KIT ROTOR		1
7	932010		DRIVE LINK	ARBRE DE LIAISON		1
8	932011		BEARING KIT	JEU DE BAGUES		1
9	932012		WEAR PLATE	PLAQUE DE DISTRIBUTION		1
10	932013		MANIFOLD	BLOC DE DISTRIBUTION		1
11	932014		COMMUTATOR ASSEMBLY	SYSTEME DE DISTRIBUTION		1
12	932015		END COVER	COUVERCLE		1
13	920040		CASTLE NUT	ECROU		1
14	920039		KEY	CLAVETTE		1

E

320024

E

HYDRAULIC MOTOR ME330 MOTEUR HYDRAULIQUE ME330

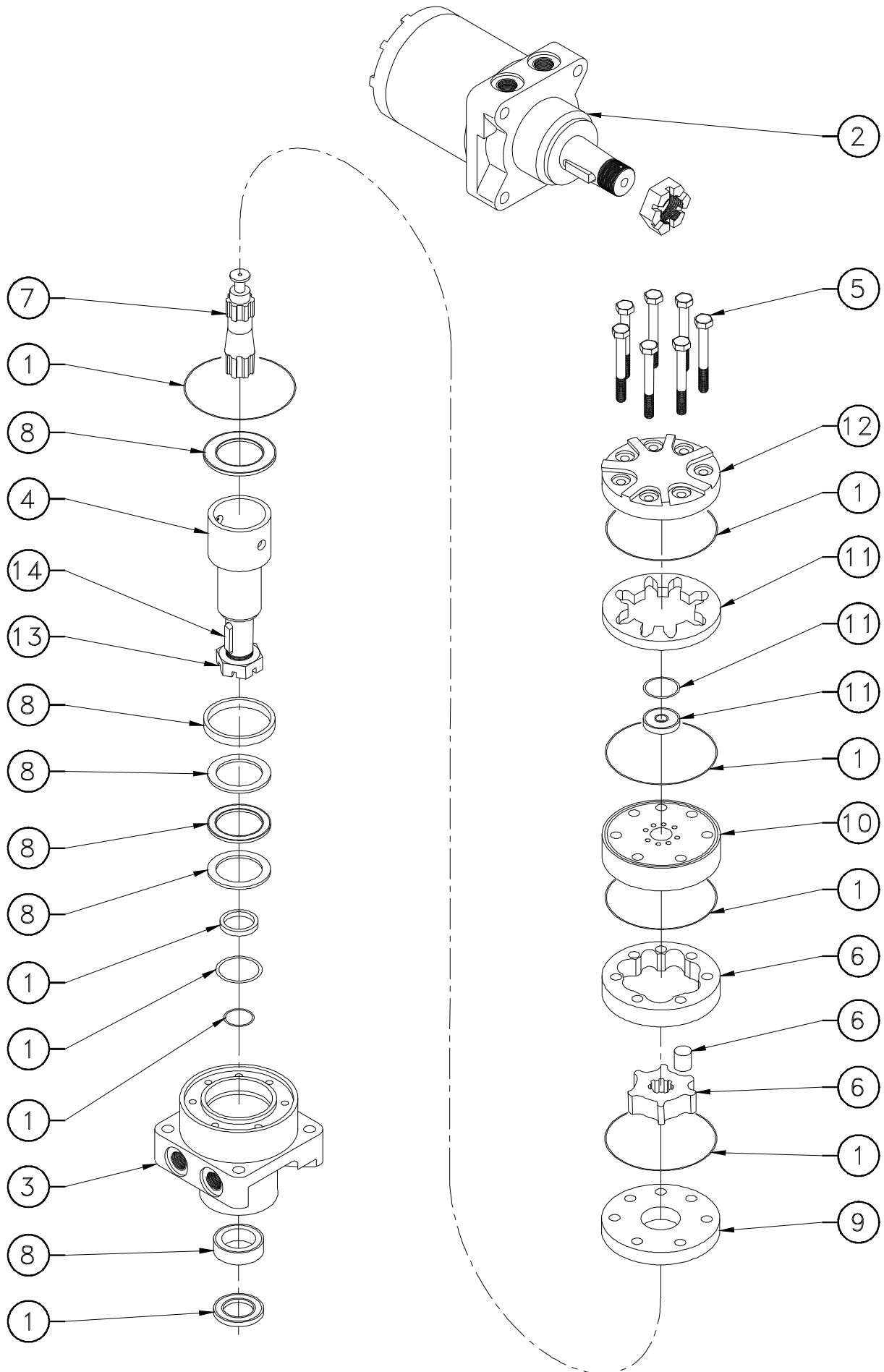

SPARE PARTS
MANUEL DE PIECES DETACHEES

SECTION F.

**CHARGER AND BATTERY INSTALL.
INSTALLATION CHARGEUR ET BATTERIE.**

FULMEN CHARGER 110/220V 65A CHARGEUR 110/220V 65A FULMEN

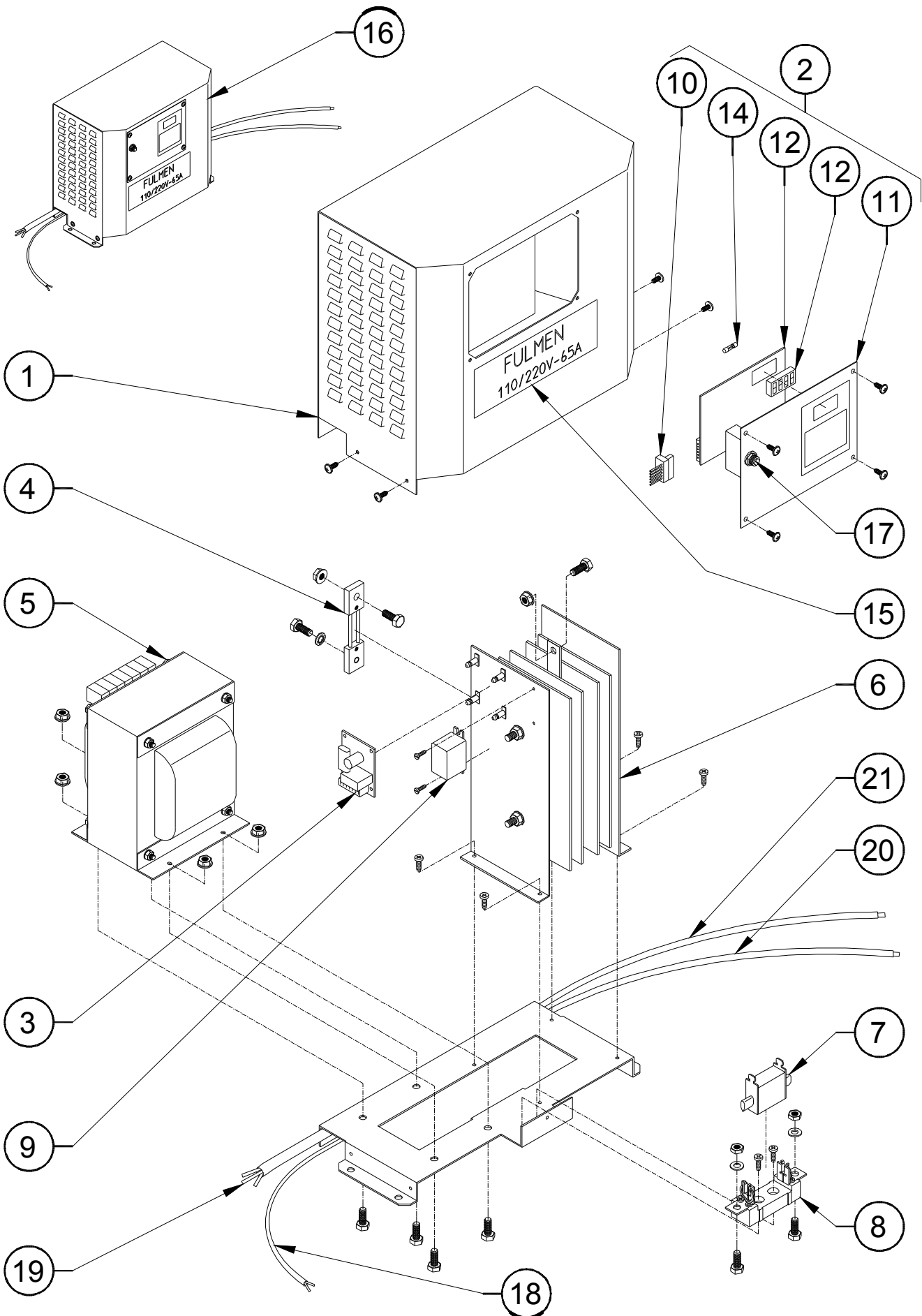

DATE : 18/03/04

OLDHAM CHARGER 110/220V 70A

MONTAGE N°/

ASSY NO : 510078 REV :

CHARGEUR 110/220V 70A OLDHAM

1/1

DET NO.	REF./PART NUMBER	VOIR/ SEE VIEW	DESCRIPTION		RE V	Qté/ Qty Req.
1	951019		NH00/80A gl FUSE	FUSIBLE NH00/80A gl		1
2	951021		32A CIRCUIT BREAKER	COUPE CIRCUIT 32A		1
3	951023		24/70V - 110/230V TRANSFORMER	TRANSFORMATEUR 24/70V - 110/230V		1
4	951025		DIODE BRIDGE PMS-70C 140x250	PONT DE DIODE PMS-70C 140x250		1
5	951026		30VA AUXILIARY TRANSFORMER	TRANSFORMATEUR AUXILIAIRE 30VA		1
6	951027		240VAC CONTACTOR	CONTACTEUR 24VAC		1
7	951028		AP 062 ELECTRONIC BOARD	CARTE ELECTRONIQUE AP 062		1
7	951032		AP 063 ELECTRONIC BOARD	CARTE ELECTRONIQUE AP 063		1
8	951029		REAR COVER	CHASSIS ARRIERE		1
9	951030		FRONT COVER	CHASSIS AVANT		1
10	951031		DECAL	AUTOCOLLANT		1

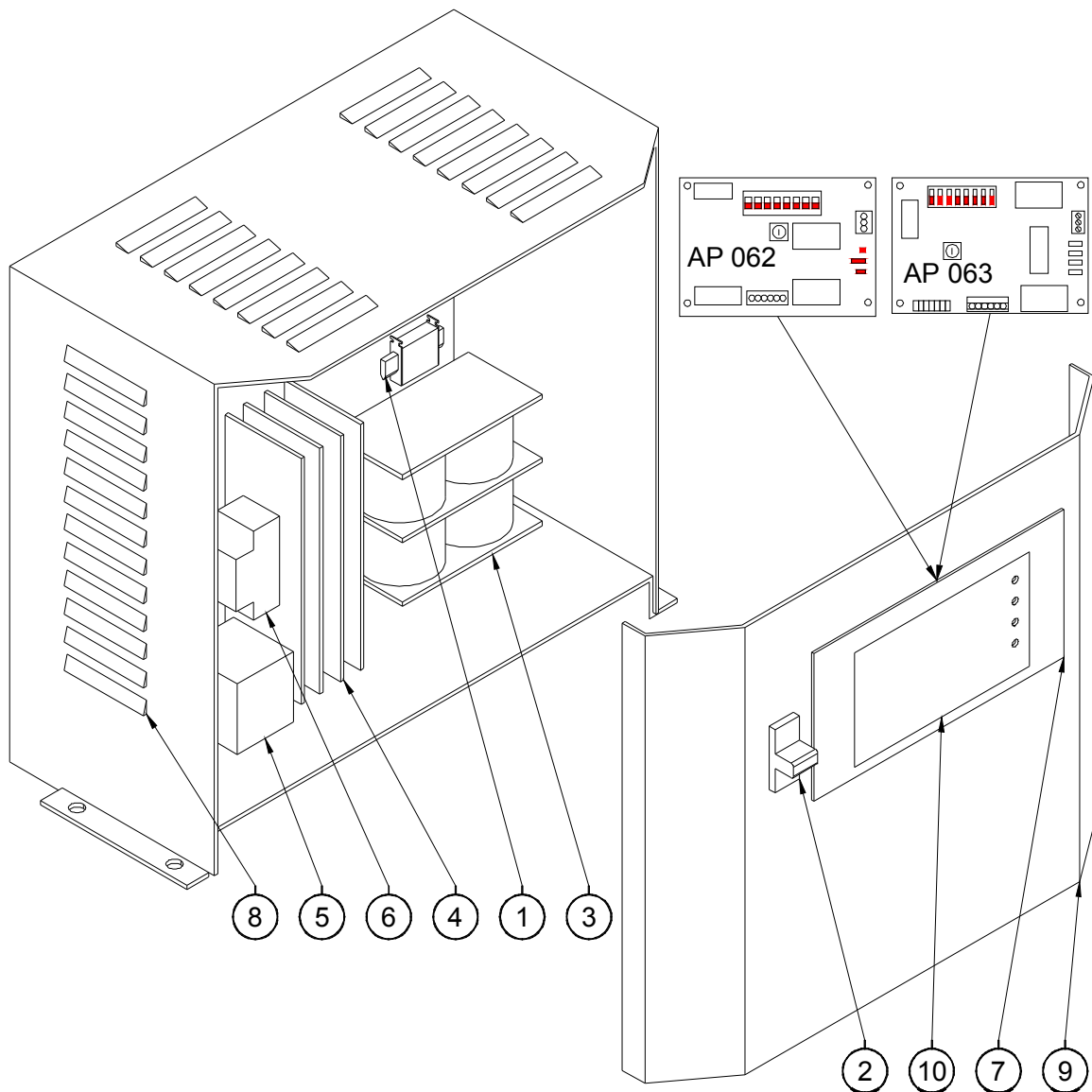

510078

DATE : 15/11/05

**OLDHAM CHARGER SELECT 110/220V
70A**

MONTAGE N°/
ASSY NO : 510082 REV :

**CHARGEUR 70A OLDHAM SELECT
110/220V**

1/1

DET NO.	REF./PART NUMBER	VOIR/ SEE VIEW	DESCRIPTION		R E V	Qté/ Qty Req.
1	951019		NH00/80A gl FUSE	FUSIBLE NH00/80A gl		1
2	951021		32A CIRCUIT BREAKER	COUPE CIRCUIT 32A		1
3	951023		24/70V - 110/230V TRANSFORMER	TRANSFORMATEUR 24/70V - 110/230V		1
4	951025		DIODE BRIDGE PMS-70C 140x250	PONT DE DIODE PMS-70C 140x250		1
5	951026		30VA AUXILIARY TRANSFORMER	TRANSFORMATEUR AUXILIAIRE 30VA		1
6	951027		240VAC CONTACTOR	CONTACTEUR 24VAC		1
7	951032		AP 063 ELECTRONIC BOARD	CARTE ELECTRONIQUE AP 063		1
8	951029		REAR COVER	CHASSIS ARRIERE		1
9	951030		FRONT COVER	CHASSIS AVANT		1
10	951031		DECAL	AUTOCOLLANT		1

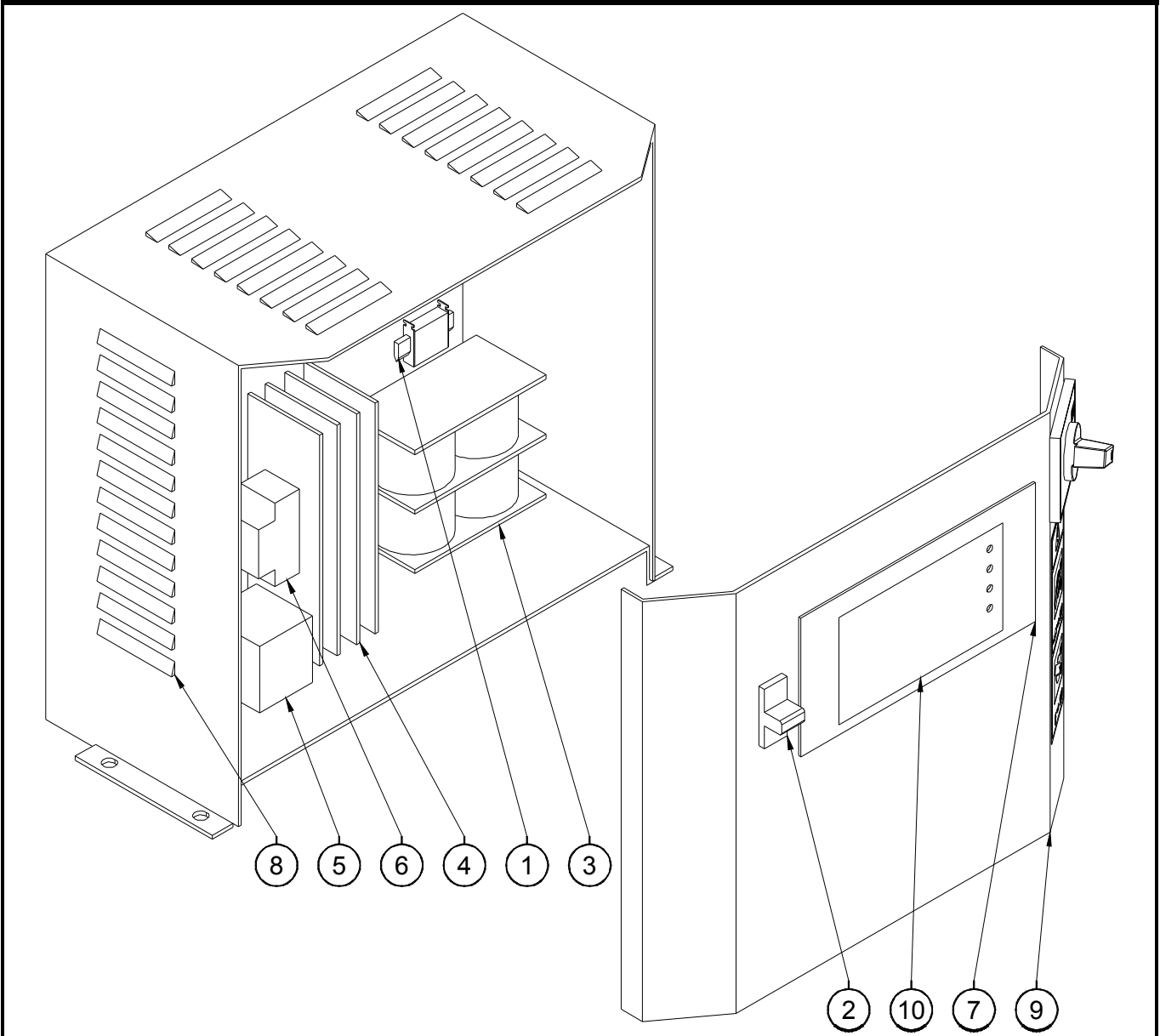

F

510082

F

ISSUE DATE : 27/05/02

80A "F7BTGR" ZIVAN CHARGER (GEL)

ISSUE REL :

ASSEMBLY N° : 510065 REV :
 N° ENSEMBLE :

CHARGEUR ZIVAN 80A "F7BTGR" (GEL)

1/1

DET REP	PART NUMBER REF.	SEE VIEW VOIR VUE	DESCRIPTION		R E V	QTY QTE
1	510065		80A "F7BTGR" ZIVAN CHARGER (GEL)	CHARGEUR ZIVAN 80A "F7BTGR" (GEL)		1
2	510060		EXTERNAL INDICATOR	INDICATEUR EXTERNE		x

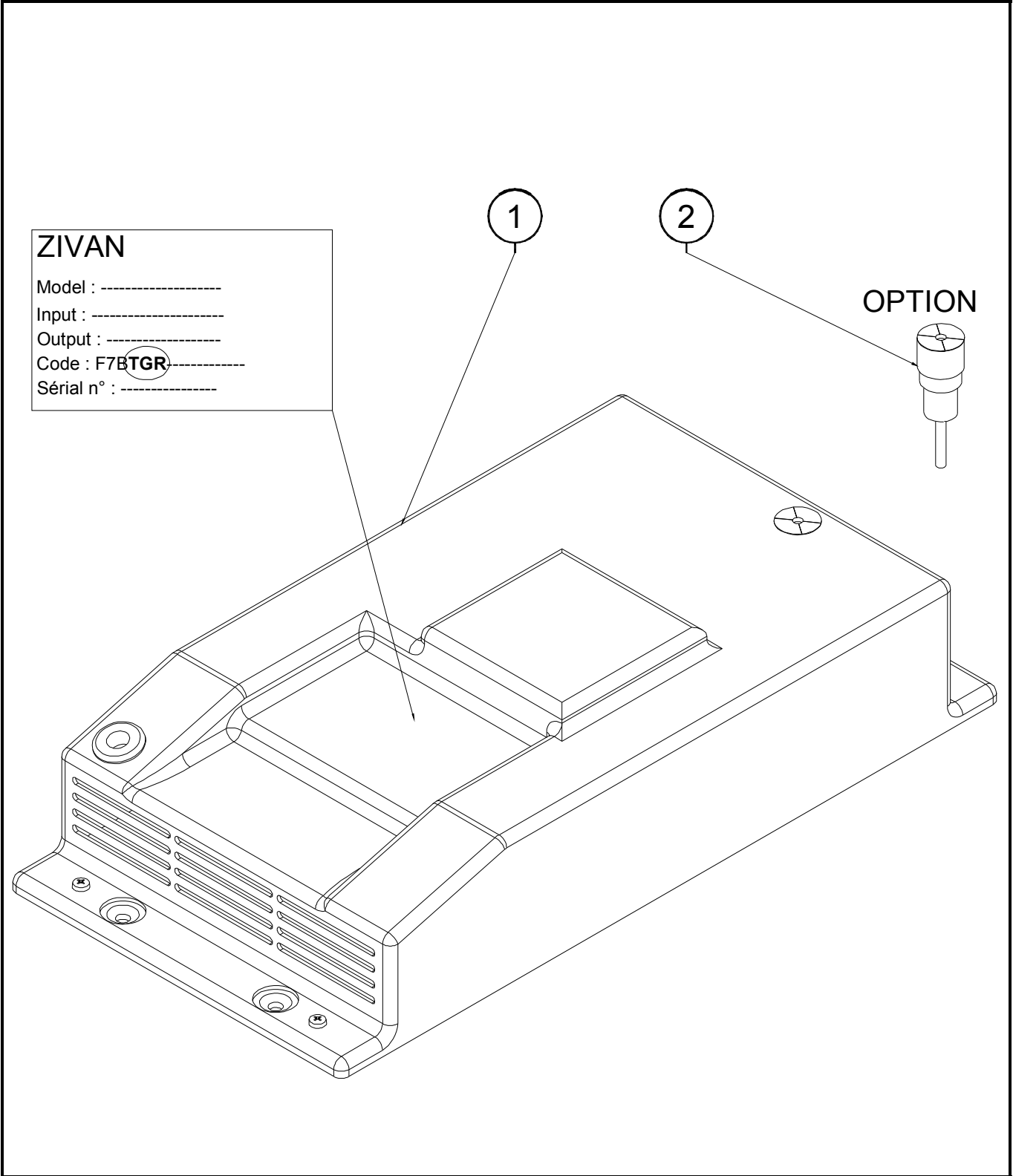

ISSUE DATE : 27/05/02

80A "F7BSTR" ZIVAN CHARGER

ISSUE REL :

ASSEMBLY N° : 510067 REV :
 N° ENSEMBLE :

CHARGEUR ZIVAN 80A "F7BSTR"

1/1

DET REP	PART NUMBER REF.	SEE VIEW VOIR VUE	DESCRIPTION		R E V	QTY QTE
1	510067		80A "F7BSTR" ZIVAN CHARGER	CHARGEUR ZIVAN 80A "F7BSTR"		1
2	510060		EXTERNAL INDICATOR	INDICATEUR EXTERNE		x

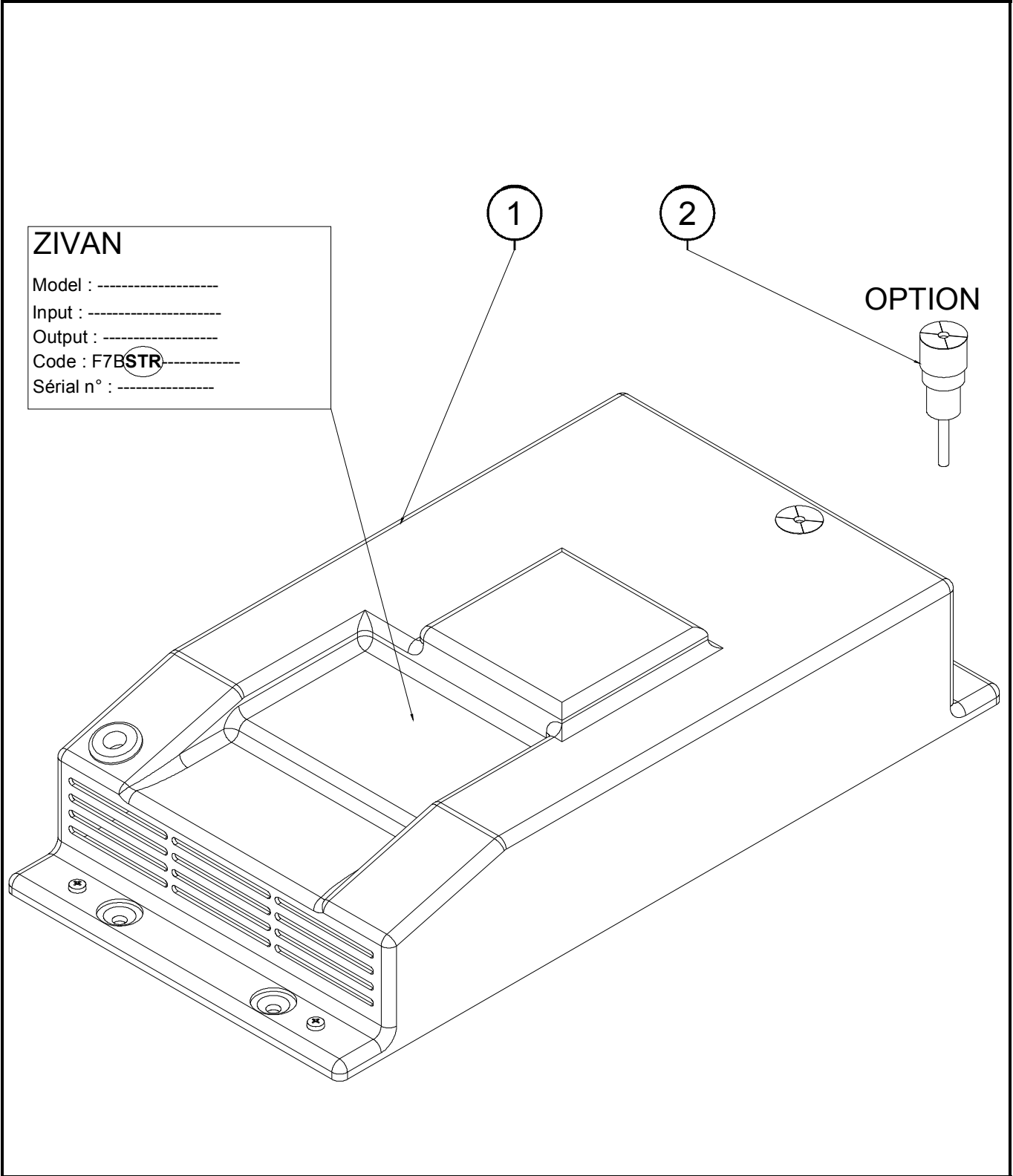

BATTERY COMPONENTS COMPOSANTS BATTERIE

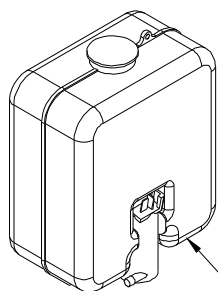

OLDHAM HAWKER	FULMEN EXIDE		SGTE FIAMM	FULMEN EXIDE	
	SGTE FIAMM			OLDHAM HAWKER	
25	13		22	4	
24	12		23	5	

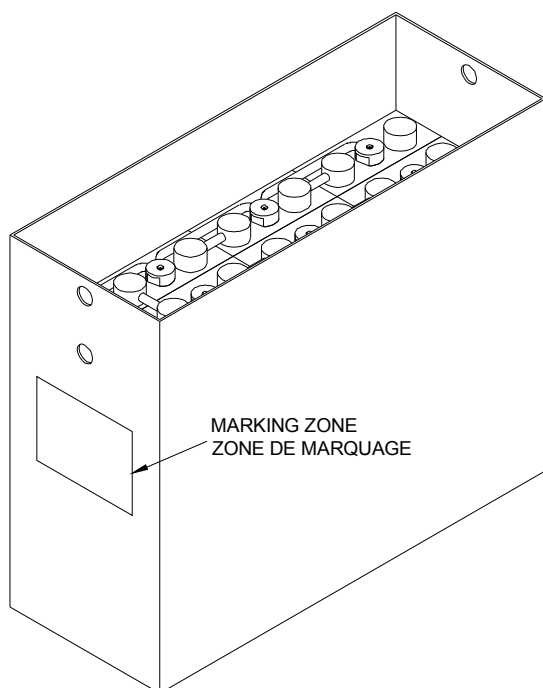
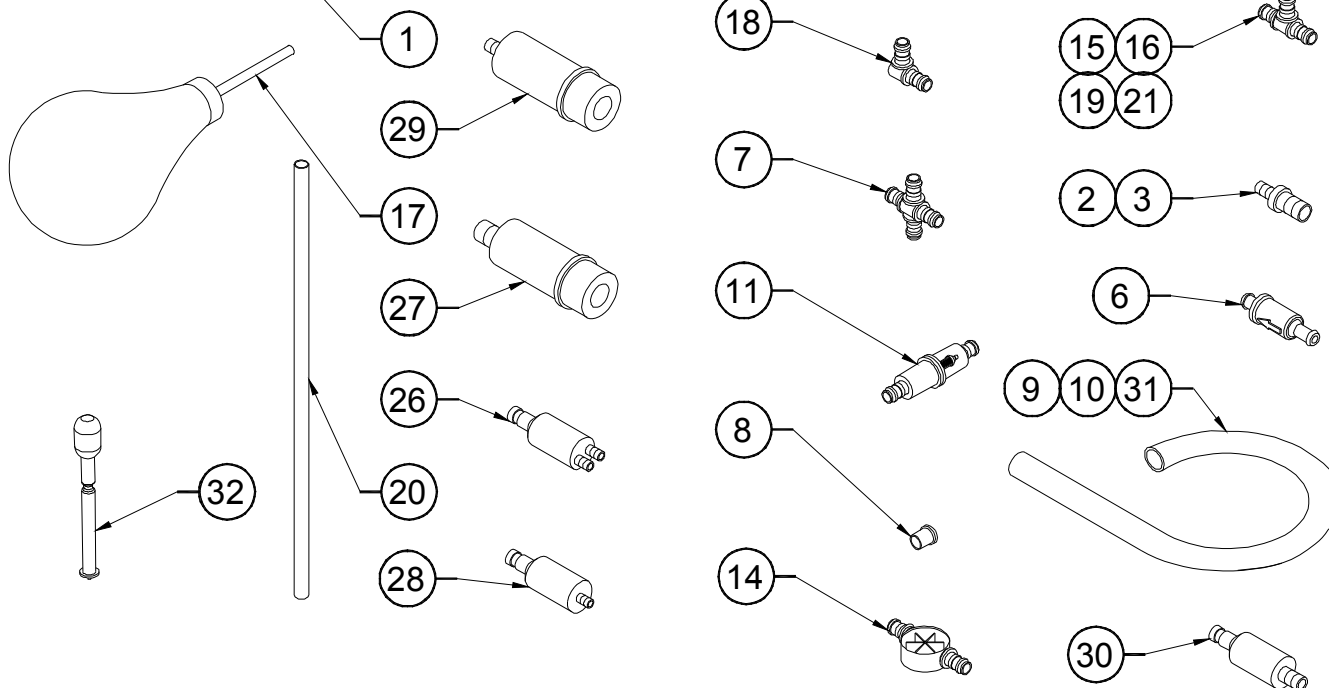

To order a battery cell (dry cell), indicate the P/N inscribed on the marking zone.

Pour commander un élément de batterie (élément sec), spécifier la référence relevée sur la zone de marquage.

ISSUE DATE : 28/05/03

BATTERY COMPONENTS

ISSUE REL :

COMPOSANTS BATTERIEASSEMBLY N° : RM0092 REV :
N° ENSEMBLE :

1/1

DET REP	PART NUMBER REF.	SEE VIEW VOIR VUE	DESCRIPTION		R E V	QTY QTE
1	400058		DISTILLED WATER CAN KIT	KIT BIDON D'EAU DISTILLEE		
2	400059		4/6 REDUCTION	REDUCTION 4/6		
3	400065		6/10 REDUCTION	REDUCTION 6/10		
4	950033		BATTERY CELL LEVEL CAP	BOUCHON NIVEAU D'ELEMNT BATTERIE		
5	950035		FLOAT	FLOTTEUR		
6	400086		SCREEN WASHER CHECK VALVE	CLAPET ANTI-RETOUR LAVE-GLACE		
7	950214		CROSS 06	CROIX 06		
8	950038		TERMINAL CAP	OBTURATEUR TERMINAL		
9	950039		Ø6 PIPE (quantity indicated in meter)	TUYAU Ø 6 (quantité indiquée en mètre)		
10	950040		Ø10 PIPE (quantity indicated in meter)	TUYAU Ø10 (quantité indiquée en mètre)		
11	950041		FILTER	FILTRE		
12	950042		MALE CONNECTOR	CONNECTEUR MALE		
13	950043		FEMALE CONNECTOR	CONNECTEUR FEMELLE		
14	950044		FLOW INDICATOR Ø10	INDICATEUR DE DEBIT Ø10		
15	950045		RUN TEE 10/10/10	TE 10/10/10		
16	950046		RUN TEE 10/06/10	TE 10/06/10		
17	950047		BATTERY BULB	POIRE BATTERIE		
18	950051		90° ELBOW 06/06	COUDE 06/06		
19	950052		RUN TEE 06/06/06	TE 06/06/06		
20	950058		PIPE	TUBE		
21	950059		RUN TEE 06/10/06	TE 06/10/06		
22	950071		CELL LEVEL CAP	BOUCHON DE FLOTTEUR		
23	950072		FLOAT	FLOTTEUR		
24	950079		MALE CONNECTOR	CONNECTEUR MALE		
25	950080		FEMALE CONNECTOR	CONNECTEUR FEMELLE		
26	950148		FILTER/FLOW INDICATOR 2xØ6	FILTRE INDICATEUR DE DEBIT 2xØ6		
27	950163		FILTER FEMALE CONNECTOR Ø10	CONNECTEUR FEMELLE FILTRE Ø10		
28	950164		FILTER/FLOW INDICATOR Ø6	FILTRE INDICATEUR DE DEBIT Ø6		
29	950165		FILTER FEMALE CONNECTOR Ø6	CONNECTEUR FEMELLE FILTRE Ø6		
30	950213		FILTER / FLOW INDICATOR Ø10	FILTRE / INDICATEUR DE DEBIT Ø10		
31	950215		Ø4 PIPE (quantity indicated in meter)	TUYAU Ø 4 (quantité indiquée en mètre)		
32	950216		HYDROMETER	PESE ACIDE		

F

RM0092

F

ISSUE DATE : 21/05/02

CHARGER CONNECTOR

ISSUE REL :

PRISE CHARGEUR

ASSEMBLY N° : RM0059 REV :
 N° ENSEMBLE :

1/1

DET REP	PART NUMBER REF.	SEE VIEW VOIR VUE	DESCRIPTION	RE V	QTY QTE
1	7364002824		US 125 VAC MALE CONNECTOR (=260276)		1
2	260213		Yellow CONNECTOR 110VAC/16A CEI, IP44		1
3	250117		UK 220 VAC MALE CONNECTOR		1
4	260231		BLUE CONNECTOR 220VAC/16A CEI, IP44		1
5	260214		FRENCH AND GERMAN 220V CONNECTOR		1
6	260263		BLUE CONNECTOR 220VAC/32A CEI, IP44		1
7	260266		Yellow CONNECTOR 110VAC/32A CEI, IP44		1

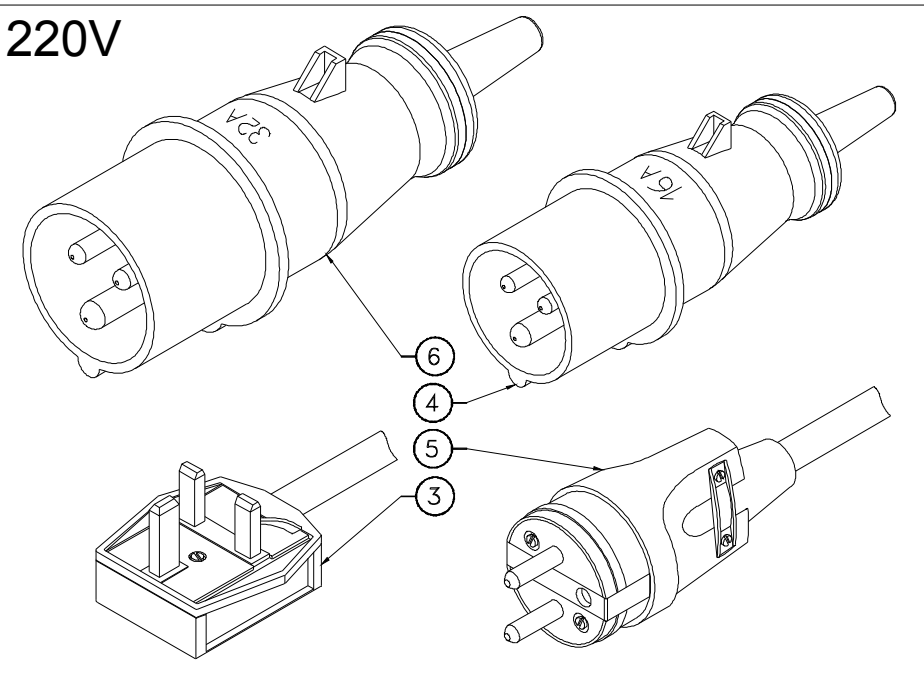
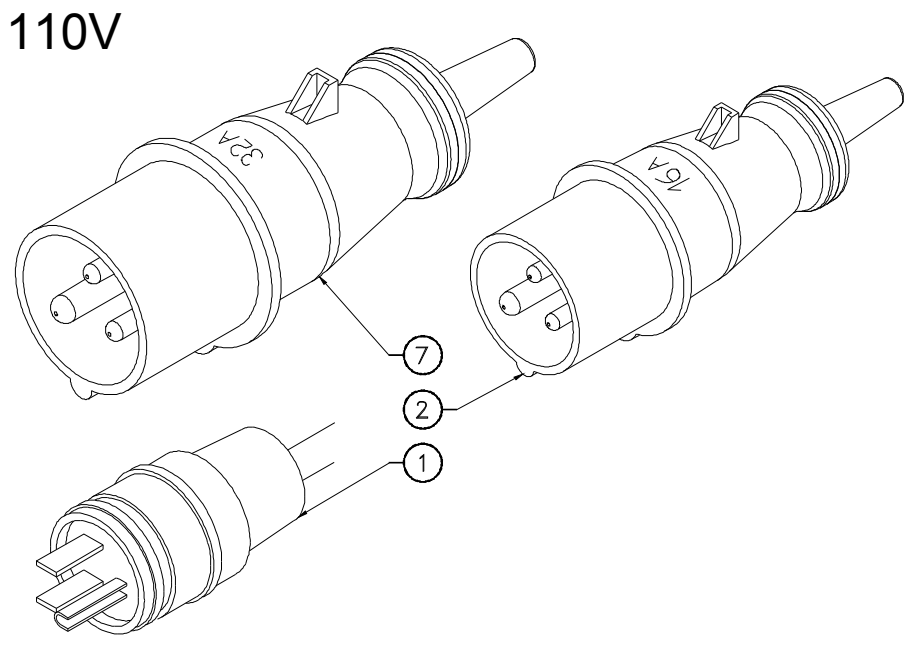

SPARE PARTS
PIECES DETACHEES

SECTION G.

CE DECALS INSTALL.
INSTALLATION DES AUTOCOLLANTS CE.

CE DECALS INSTALL INSTALLATION AUTOCOLLANTS CE

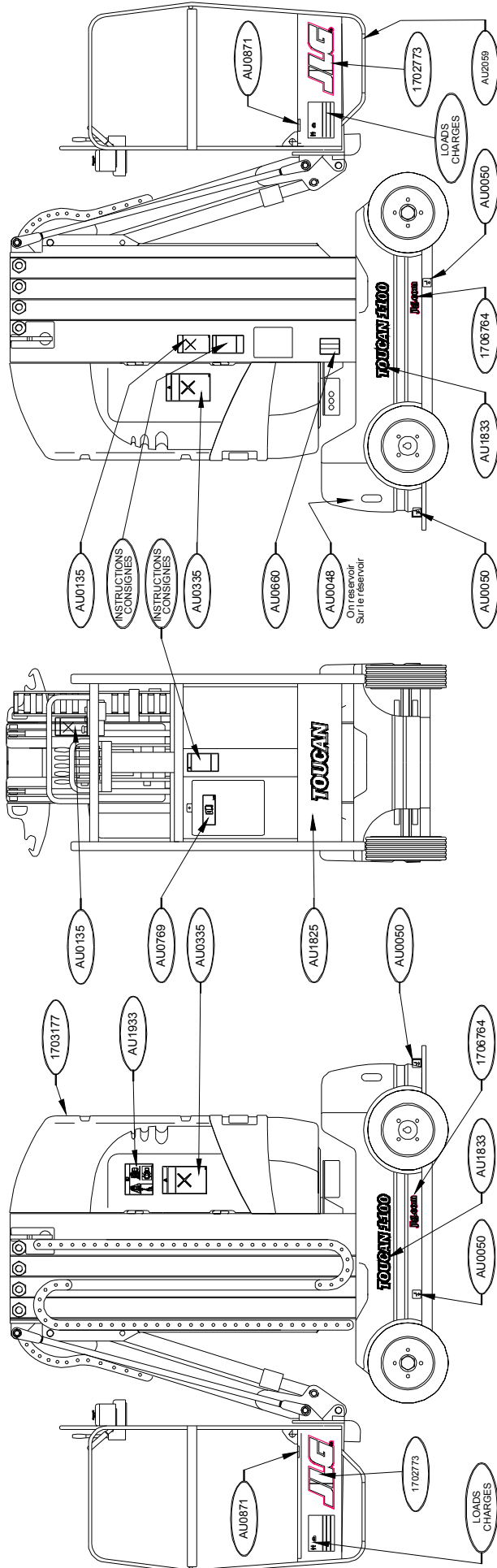

Repère	Nb	Repère	Nb
AU2062	1	AU1825	1
AU2059	2	AU1423	1
1706764	2	AU0871	2
1706483	2	AU0769	1
1703177	1	AU0660	1
1702773	2	AU0335	2
AU1933	1	AU0135	2
AU1833	2	AU0050	4
		AU0048	1

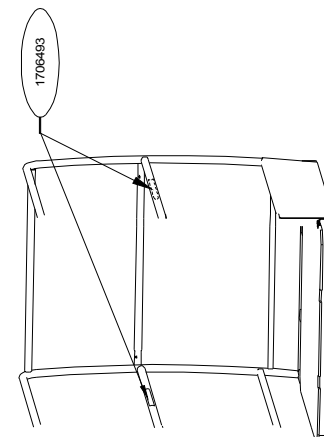
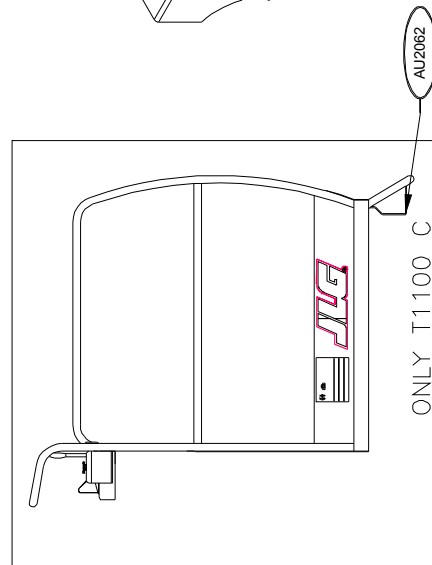
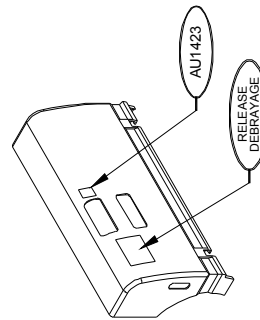

ALL CE MODELS DECALS INSTALL INSTALLATION AUTOCOLLANTS POUR TOUS MODELES CE

		STANDARD PLATFORM / PANIER STANDARD			LARGE ALUMINIUM PLATFORM / GRAND PANIER ALU.		
		LOAD / CHARGE x2	INSTRUCTIONS / CONSIGNES x2	RELEASE / DEBRAYAGE x1	LOAD / CHARGE x1	INSTRUCTIONS / CONSIGNES x2	RELEASE / DEBRAYAGE x1
Danemark/Denmark	DK	AU0990	AU1576	AU0739	AU0990	AU1576	AU0739
		PA0816			PA0827		
Dutch/Hollande	NL	AU0684	AU1580	AU0653	AU0684	AU1580	AU0653
		PA0820			PA0912		
Finland/Finlande	FIN	AU1033	AU1578	AU1035			
		PA0818					
France	F	AU0663	AU1569	AU0475	AU0663	AU1569	AU0475
		PA0811			PA0812		
Germany/Allemagne Austria/Autriche	D A	AU0677	AU1575	AU0620	AU0677	AU1575	AU0620
		PA0815			PA0826		
Greece/Grèce	GR	AU1539	AU1579	AU1540	AU1539	AU1579	AU1540
		PA0819			PA0819		
Italy/Italie	I	AU0692	AU1581	AU0688	AU0692	AU1581	AU0688
		PA0821			PA0832		
Norway/Norvège	N	AU0750	AU1582	AU0748	AU0750	AU1582	AU0748
		PA0822			PA0833		
Poland/Pologne	PL	AU1114	AU1583	AU0626			
		PA0823					
Portuguese/Portugal	P	AU1805	AU1804	AU1036	AU1805	AU1804	AU1036
		PA0931			PA0932		
Spain/Espagne	E	AU0824	AU1577	AU0659	AU0824	AU1577	AU0659
		PA0817			PA0828		
Sweden/Suède	S	AU1001	AU1584	AU0925	AU1001	AU1584	AU0925
		PA0824			PA0835		
Switzerland/Suisse	F D	AU0663	AU1569	AU0475	AU0663	AU1569	AU0475
		AU0677	AU1575	AU0620	AU0677	AU1575	AU0620
United Kingdoms/ Royaume uni	GB	AU0674	AU1574	AU0501	AU0674	AU1574	AU0501
		PA0814			PA0825		

PAxxxx = COMPLETE KIT / JEU COMPLET

Upper control valve decal / Autocollant distributeur haut	AU0015
---	--------

SPARE PARTS
PIECES DETACHEES

SECTION H.

STANDARD PLATFORM INSTALL.
INSTALLATION DU PANIER STANDARD.

STANDARD PLATFORM INSTALL INSTALLATION DU PANIER STANDARD

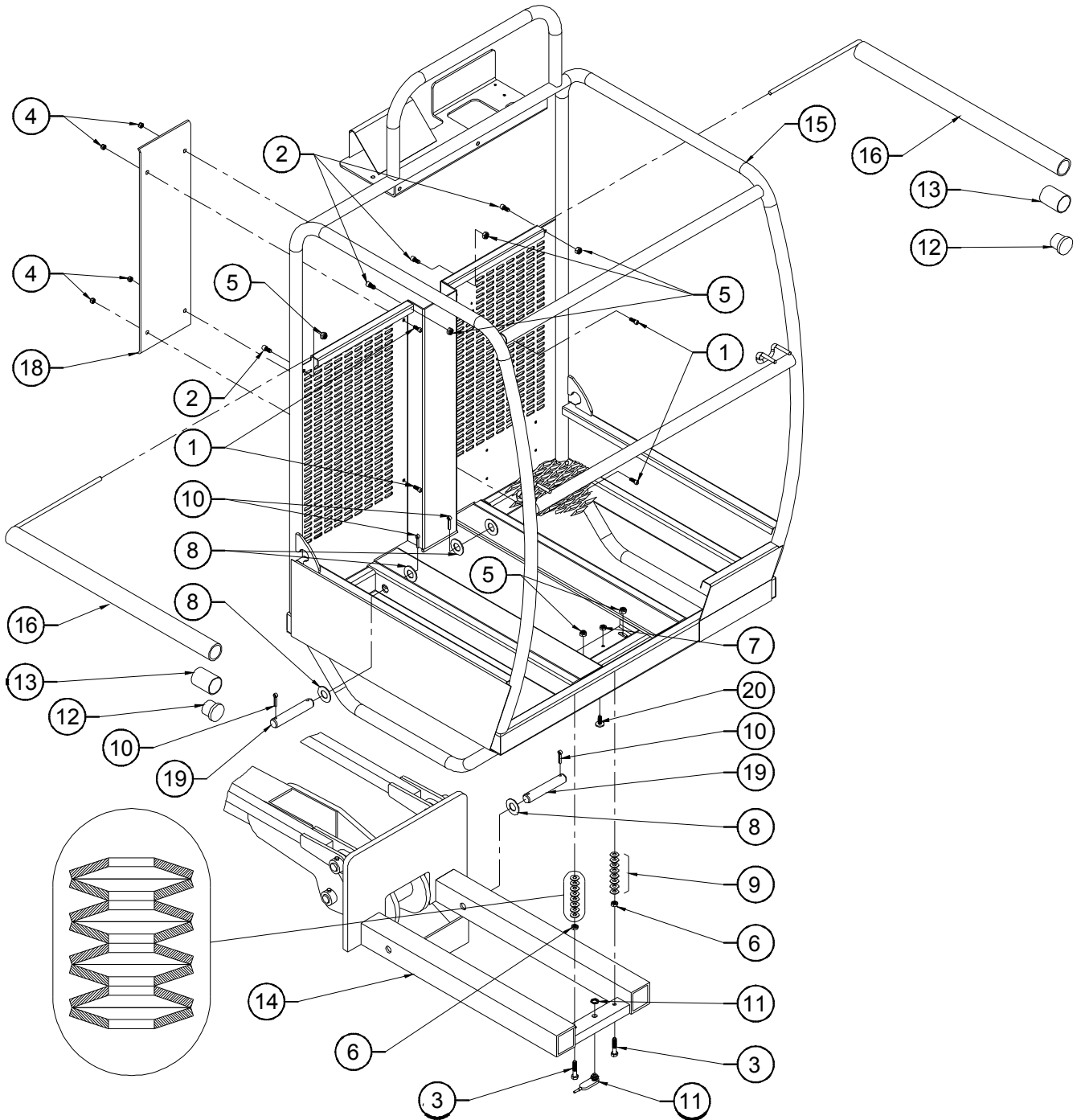

DATE : 25/01/06

STANDARD PLATFORM INSTALL

MONTAGE N°/

ASSY NO : SP0220 REV : C

INSTALLATION PANIER STANDARD

1/1

DET NO.	REF./PART NUMBER	VOIR/SEE VIEW	DESCRIPTION		RE V	Qté/Qty Req.
1	000015		M06x16 8.8 SOCKET HEAD MACH SCREW	VIS CHC M06x16 8.8 BI FT		4
2	000018		M08x16 8.8 SOCKET HEAD MACH SCREW	VIS CHC M08x16 8.8 BI FT		4
3	100029		M08x40 8.8 HEX HEAD MACHINE SCREW	VIS H M08x40 8.8 BI FT		2
4	110003		M06 GR. 8.8 LOCK NUT	ECROU FREIN M6 8.8 BI		4
5	110004		M08 GR. 8.8 LOCK NUT	ECROU FREIN M8 8.8 BI		6
6	110016		M08 GR. 8.8 HEX NUT	ECROU H M08 8.8 BI		2
7	110022		M08 GR. 8.8 FLAT HEX NUT	ECROU Hm M08 8.8 ZI		1
8	120003		Ø20x37x3 WASHER	RONDELLE Ø20x37x3 BI		4
9	120005		Ø20x8.2x0.8 SPRING WASHER	RONDELLE RESSORT Ø20x8.2x0.8 BR		16
10	140001		COTTER PIN Ø4.5x40	GOUPILLE FENDUE Ø4.5x40		4
11	260015		OVERLOAD SENSOR	DETECTEUR DE SURCHARGE		1
12	400048		CAP	BOUCHON	B	2
13	280033		Black Heat Shrink Sleeve 34/7 (qty in meter)	GAINES THERMO NOIRE 34/7 (qté en mètre)	B	2x0.05
14	DL0125		PLATFORM SUPPORT	SUPPORT PANIER		1
15	DL0774		STANDARD PLATFORM	PANIER STANDARD	C	1
16	DL0564		FLAP	PORTILLON	B	2
17			NOT REQUIRED	NON REQUIS	B	
18	ST0304		HOSES PLATE	TOLE FLEXIBLES		1
19	US0211		PLATFORM MOUNTING PIN	AXE DE PANIER	A	1
20	US0236		SETTING SCREW	VIS DE REGLAGE		1

H

H

SPARE PARTS
PIECES DETACHEES

SECTION H.

LARGE ALUMINIUM PLATFORM INSTALL.
INSTALLATION DU GRAND PANIER ALUMINIUM.

LARGE ALUMINIUM PLATFORM INSTALL INSTALLATION DU GRAND PANIER ALUMINIUM

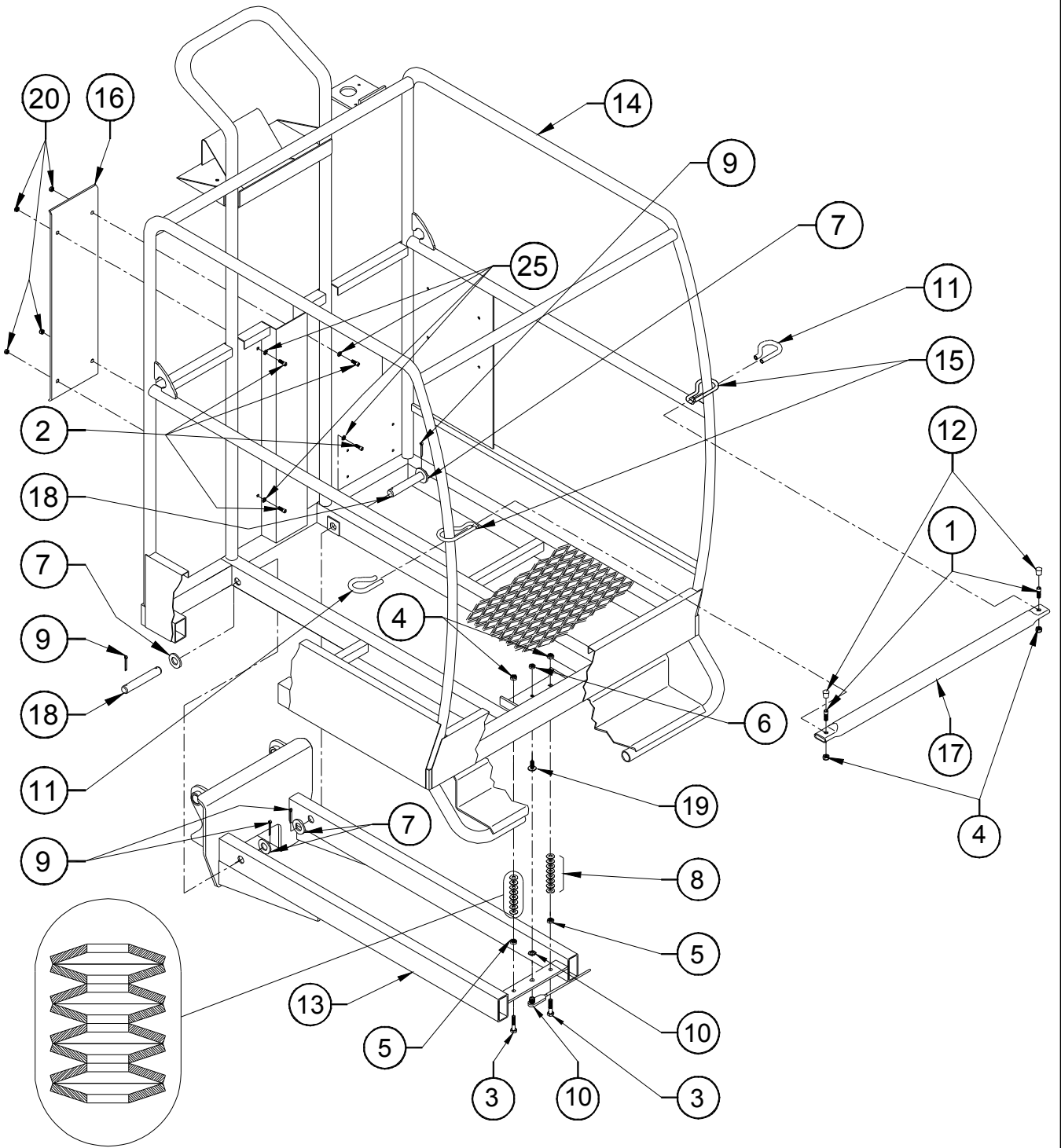

DATE : 12/05/99

**LARGE ALUMINIUM PLATFORM
INSTALL**

MONTAGE N°/

ASSY NO : SP0216 REV : B

INSTALLATION GRAND PANIER ALU

1/1

DET NO	REF./PART NUMBER	VOIR/ SEE VIEW	DESCRIPTION		R E V	Qté/ Qty Req.
1	000006		M08x20 8.8 SOCKET HEAD MACH SCREW	VIS CHC M08x20 8.8 BI FT		2
2	000015		M06x16 8.8 SOCKET HEAD MACH SCREW	VIS CHC M06x16 8.8 BI FT		4
3	100029		M08x40 8.8 HEX HEAD MACHINE SCREW	VIS H M08x40 8.8 BI FT		2
4	110004		M08 GR. 8.8 LOCK NUT	ECROU FREIN M8 8.8 BI		4
5	110016		M08 GR. 8.8 HEX NUT	ECROU H M08 8.8 BI		2
6	110022		M08 GR. 8.8 FLAT HEX NUT	ECROU Hm M08 8.8 ZI		1
7	120003		M20 WASHER	RONDELLE M20 BI		4
8	120005		Ø20x8.2x0.8 SPRING WASHER	RONDELLE RESSORT Ø20x8.2x0.8 BR		16
9	140001		COTTER PIN Ø4.5x40	GOUPILLE FENDUE Ø4.5x40		4
10	260015		OVERLOAD SENSOR	DETECTEUR DE SURCHARGE		1
11	280023		PROTECTION SLEEVE (quantity in meter)	GAINE DE PROTECTION (qté en mètre)		2
12	400026		RUBBER CAP	CHAPEAU DE VIS		2
13	DL0383		PLATFORM SUPPORT	SUPPORT PANIER		1
14	DL0773		LARGE ALUMINIUM PLATFORM	GRAND PANIER ALUMINIUM	B	1
15	ST0736		SLIDING GATE LOOP	ANNEAU PORTILLON		2
16	ST0757		HOSES PLATE	TOLE FLEXIBLES		1
17	ST0763		PLATFORM SLIDING GATE	PORTILLON		1
18	US0188		PLATFORM MOUNTING PIN	AXE DE PANIER		2
19	US0236		SETTING SCREW	VIS DE REGLAGE		1
20	110003		M06 GR. 8.8 LOCK NUT	ECROU FREIN M6 8.8 BI		4
21			NOT REQUIRED	NON REQUIS	B	
22			NOT REQUIRED	NON REQUIS	B	
23			NOT REQUIRED	NON REQUIS	B	
24			NOT REQUIRED	NON REQUIS	B	
25	120009		dD 06x14 LOCK WASHER	RONDELLE CONTACT dD 06x14 BI		4

H

SP0216

H

SPARE PARTS
PIECES DETACHEES

OPTIONS



SPARE PARTS
PIECES DETACHEES

OPTION.

EN280 INSTALL.
INSTALLATION EN280.



9 m DRIVE CUTTING INSTALL INSTALLATION DE LA COUPURE TRANSLATION 9 m

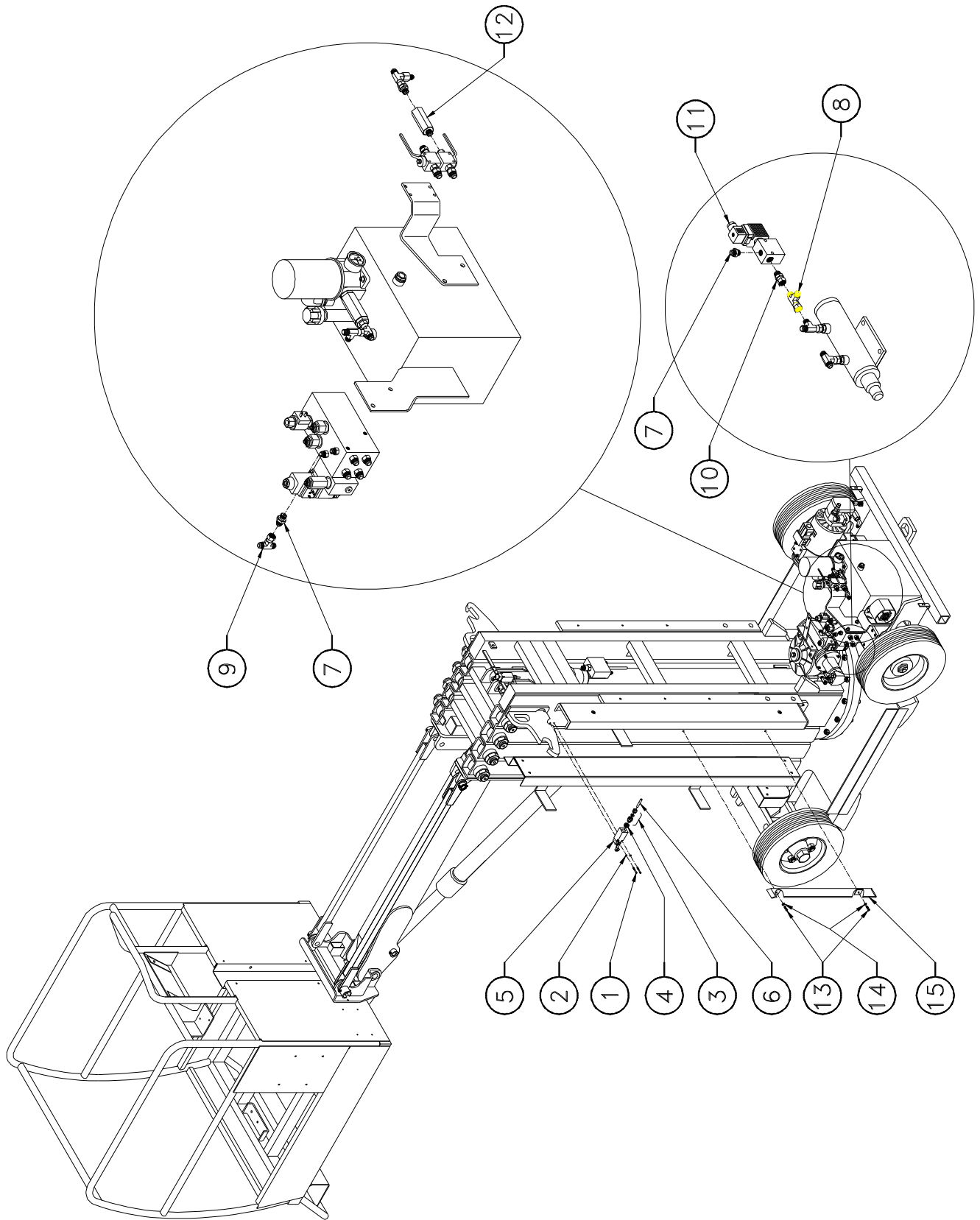

DATE : 28/01/98

SOLENOID

MONTAGE N°/

ASSY NO : 310033 REV :

ELECTROVANNE

1/1

DET NO.	REF./PART NUMBER	VOIR/ SEE VIEW	DESCRIPTION		REVISION	Qté/ Qty Req.
1	960032		SOLENOID BLOCK	BLOC ELECTROVANNE		1
2	910005		24 VDC COIL	BOBINE ELECTROCLAPET 24 VDC		1
3	900080		CARTRIDGE VALVE	ELECTROCLAPET		1
4	900075		SEAL KIT	KIT DE JOINTS		1
5	900087		HIRSHMAN CONNECTOR	CONNECTEUR HIRSHMAN		1

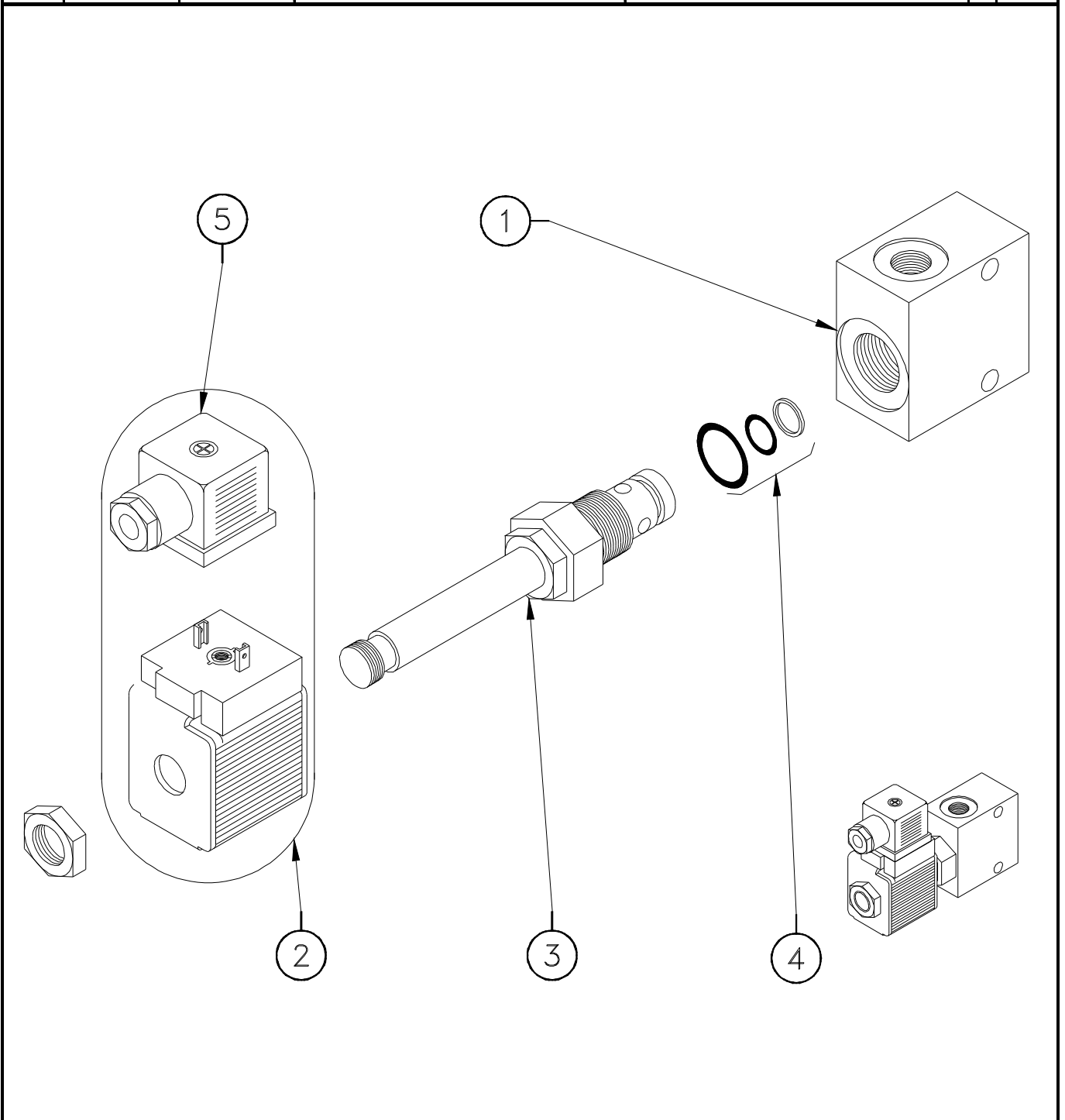

ISSUE DATE : 13/03/08

UPPER CONTROL VALVE GRID INSTALL

ISSUE REL :

ASSEMBLY N° : OP397 REV :

INSTALLATION GRILLE SUR DIST. HAUT

1/1

DET REP	PART NUMBER REF.	SEE VIEW VOIR VUE	DESCRIPTION		R E V	QTY QTE
1	000053		M08x25 8.8 SOCKET HEAD MACH SCREW	VIS CHC M08x25 8.8 BI FT		4
2	110004		M08 GR. 8.8 LOCK NUT	ECROU FREIN M8 8.8 BI		4
3	120010		dD 08x18 LOCK WASHER	RONDELLE CONTACT dD 08x18 BI		6
4	120026		dD 08x40 WASHER	RONDELLE dD 08x40 BI		2
5	140014		LOCKING PIN RING	ANNEAU INDEX		1
6	160016		LOCKING PIN SPRING	RESSORT INDEX		1
7	AU0532		CONTROL VALVE DECAL	AUTOCOLLANT DISTRIBUTEUR		1
8	ST2181		CONTROL VALVE GRILL	GRILLE DISTRIBUTEUR		1
9	ST2183		CONTROL VALVE GRILL SUPPORT	SUPPORT GRILLE DISTRIBUTEUR		1
10	US0290		LOCKING PIN	INDEX		1
11	US0291		LOCKING PIN BARREL	FOURREAU D'INDEX		1
12	US0299		SPACER	ENTRETOISE		2
13	US0317		LOCKING PIN WASHER	RONDELLE INDEX		1

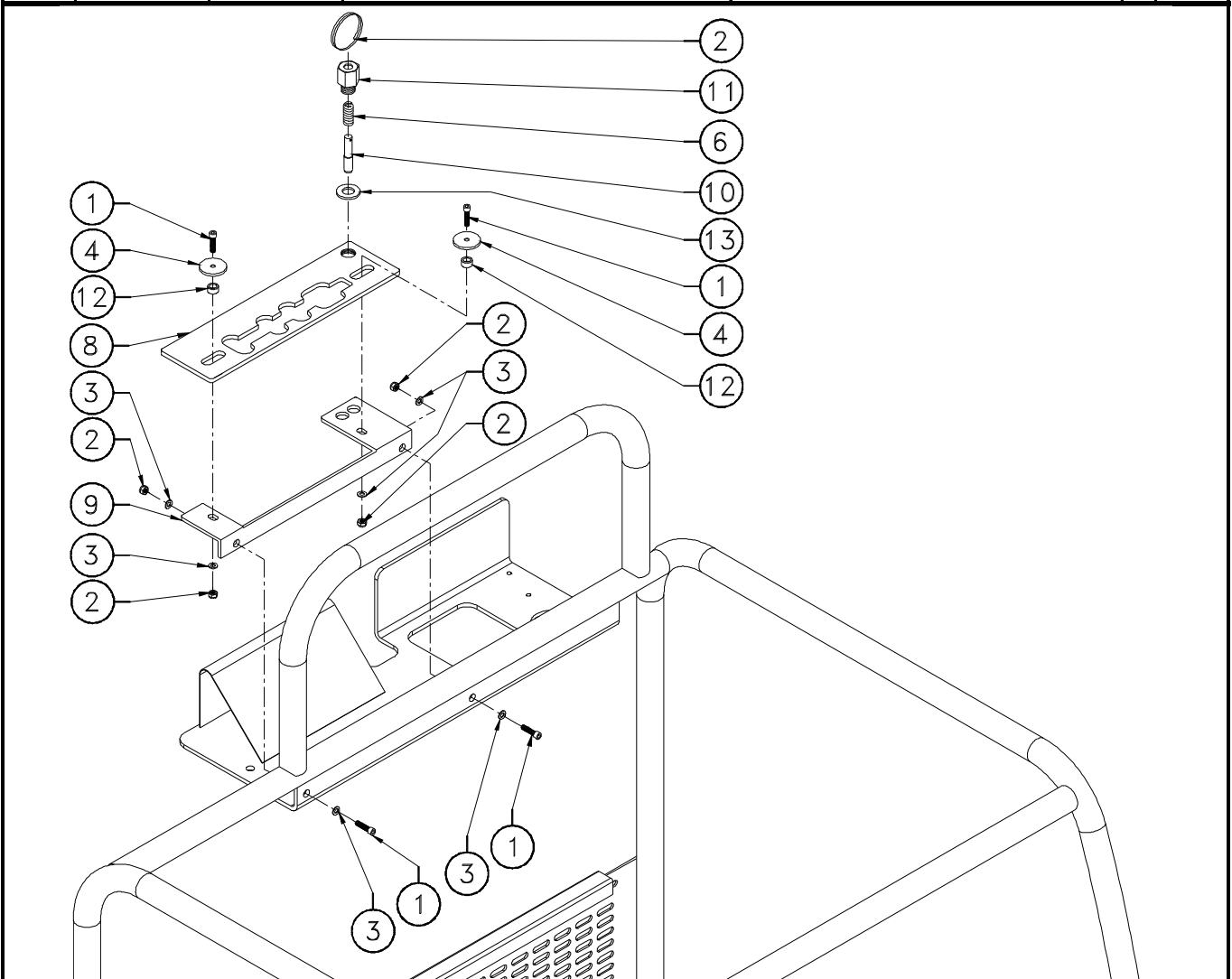

SPARE PARTS
PIECES DETACHEES

OPTION.

DISPLAY PANEL INSTALL.
INSTALLATION PORTE AFFICHE.

SMALL PLATFORM DISPLAY PANEL ASSEMBLY ASSEMBLAGE PORTE AFFICHE PETITE PLATE-FORME

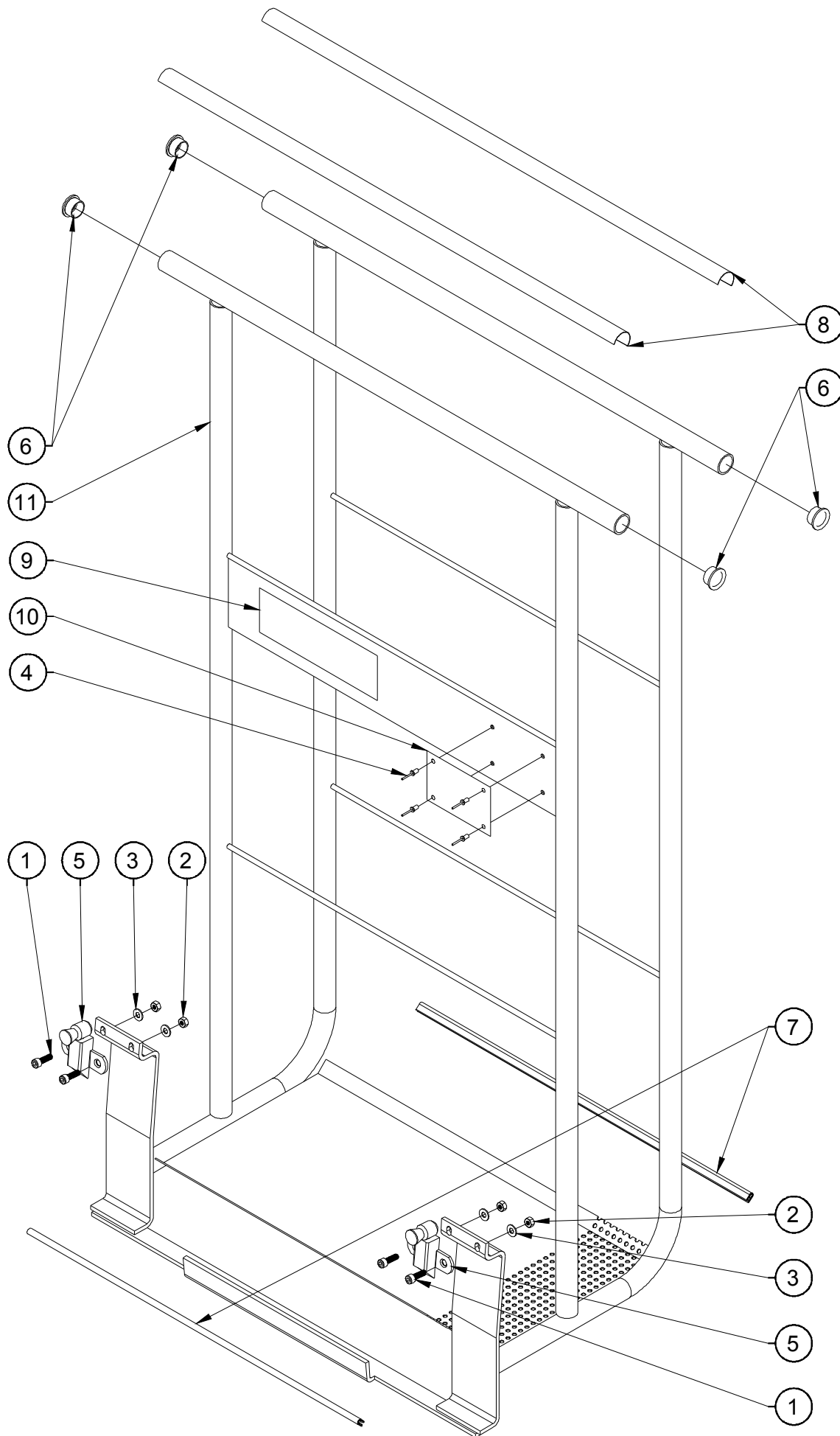

LARGE PLATFORM DISPLAY PANEL ASSEMBLY

ASSEMBLAGE PORTE AFFICHE GRANDE PLATE-FORME

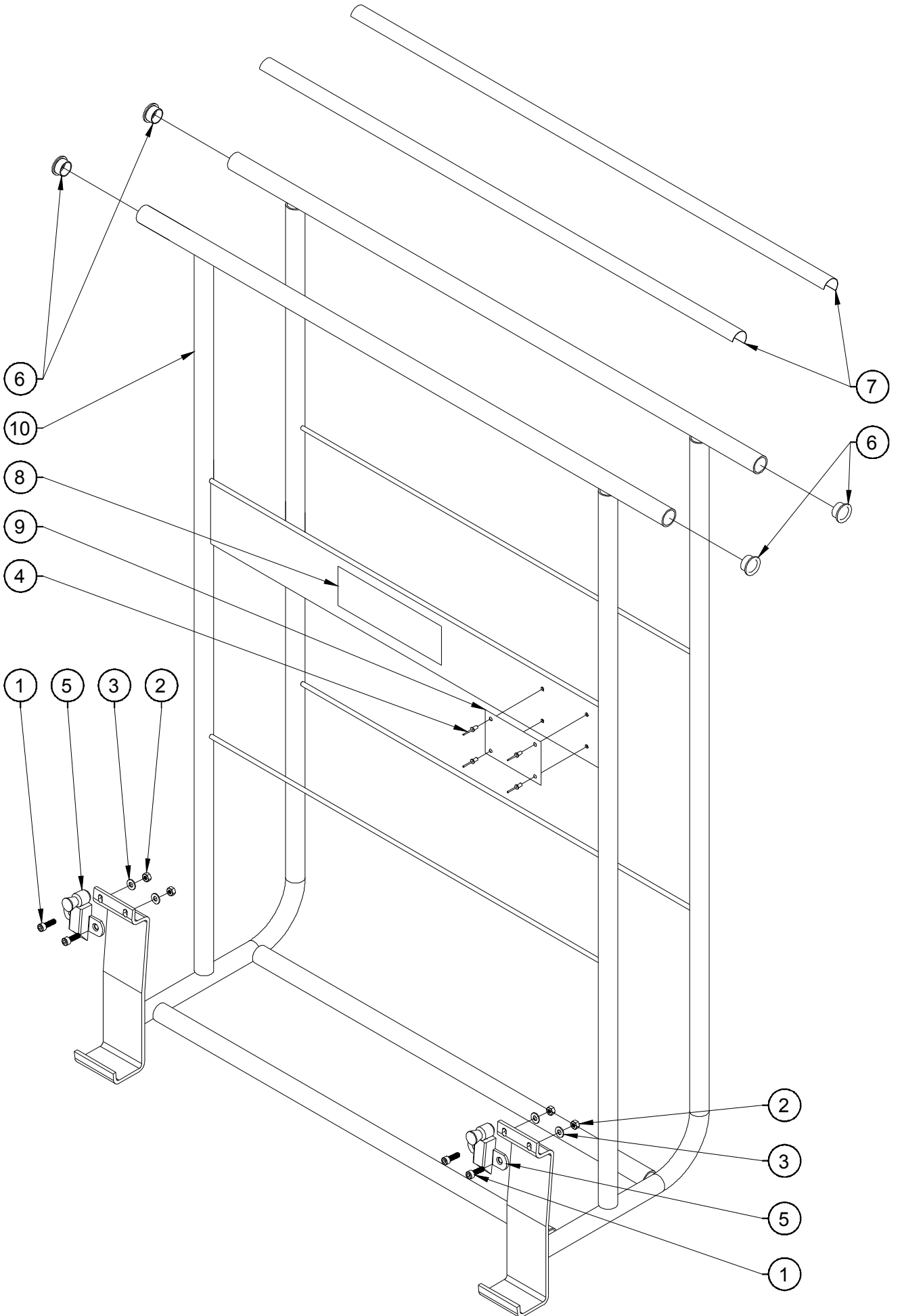

SPARE PARTS
PIECES DETACHEES

OPTION.

230VAC SOCKET INSTALL.
INSTALLATION PRISE 230V.

230VAC FRENCH SOCKET INSTALL INSTALLATION PRISE FRANCAISE 230V

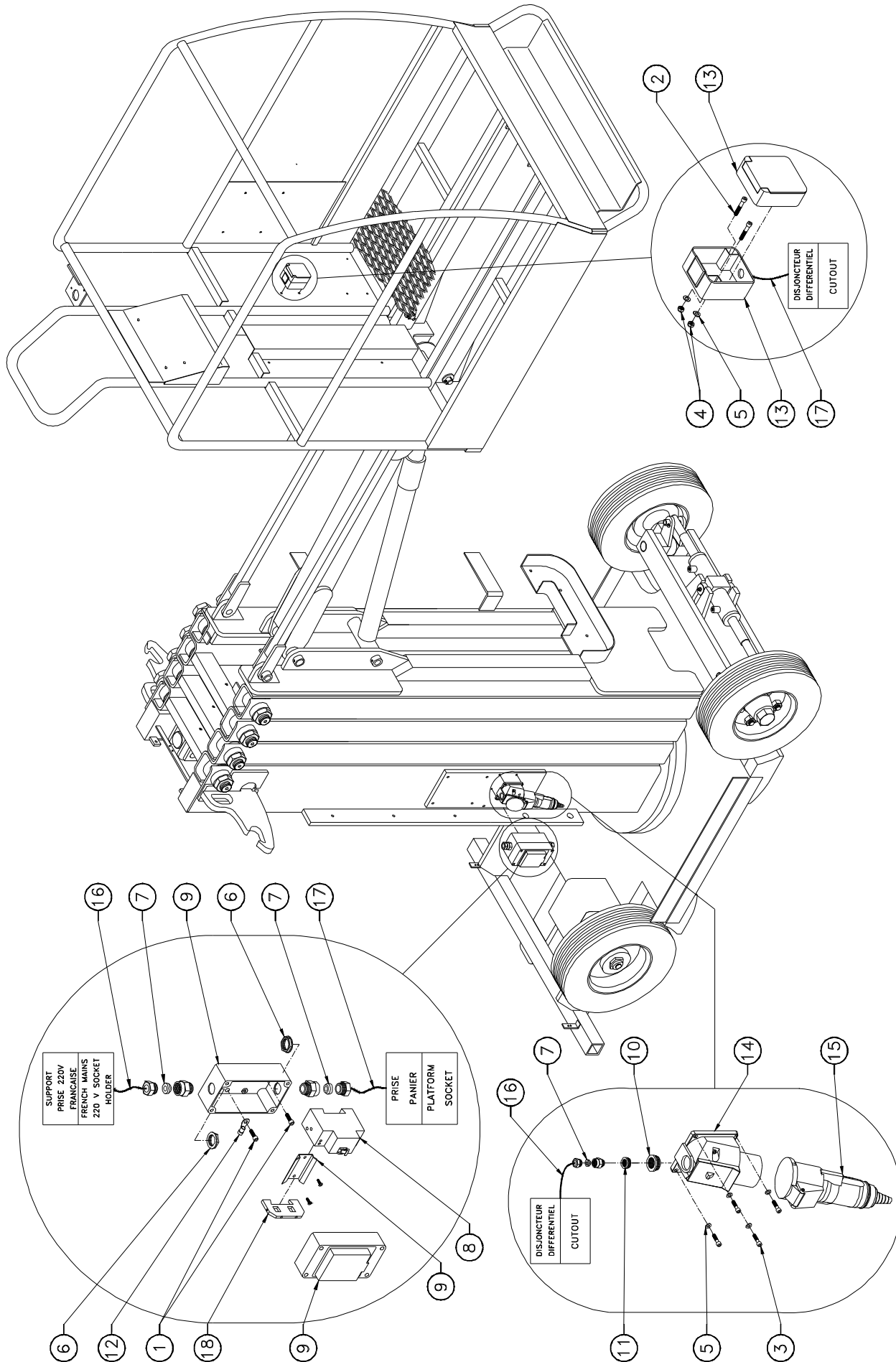

ISSUE DATE : 13/03/08

230V FRENCH PLATFORM SOCKET INSTALL

ISSUE REL :

ASSEMBLY N° : OP049 REV :
N° ENSEMBLE :

INSTALLATION PRISE PANIER 230V FRANCAISE

1/1

DET REP	PART NUMBER REF.	SEE VIEW VOIR VUE	DESCRIPTION		R E V	QTY QTE
1	000015		M06x16 8.8 SOCKET HEAD MACH SCREW	VIS CHC M06x16 8.8 BI FT		2
2	000085		M04x16 8.8 SOCKET HEAD MACH SCREW	VIS CHC M04x16 8.8 BI FT		2
3	000050		M04x10 8.8 SOCKET HEAD MACH SCREW	VIS CHC M04x10 8.8 BI FT		4
4	110001		M04 GR. 8.8 LOCK NUT	ECROU FREIN M4 8.8 BI		2
5	120024		M04 LOCK WASHER	RONDELLE CONTACT M04 BI		8
6	210009		GLAND N°9 NUT	ECROU DE PRESSE ETOUPE N°9		2
7	210017		GLAND N°9	PRESSE ETOUPE N°9		3
8	240015		CUTOUT 30 mA	DISJONCTEUR DIFFERENTIEL 30 mA		1
9	240093		CUTOUT BOX	BOITIER DISJONCTEUR		1
10	250047		16/13 REDUCTION	REDUCTION 16/13		1
11	250015		REDUCTION 13/9	REDUCTION 13/9		1
12	250096		M06 EYELET TERMINAL 4-6mm²	COSSE A ŒIL ISOLEE M6 - 4-6mm²		1
13	260029		FRENCH 230 VAC SOCKET 2P+T	PRISE FEM. FRANCAISE 230VAC 2P+T		1
14	260032		230 VAC SURFACE PLUG	PRISE MALE FIXE 230VAC		1
15			NOT REQUIRED	NON REQUIS		
16	270051		CABLE 3G2.5mm² Color leads (qty in meters)	CABLE 3G2.5mm² coloré (qté en mètre)		0.3
17	270051		CABLE 3G2.5mm² Color leads (qty in meters)	CABLE 3G2.5mm² coloré (qté en mètre)		12
18	250135		TERMINAL BLOCK VICKING	BLOC DE JONCTION VICKING		1
19	AU1163		230 VAC DECAL	AUTOCOLLANT 230VAC		2
20	AU1716		PLATFORM SOCKET DECAL	AUTOCOLLANT PRISE PANIER		1

230VAC GERMAN SOCKET INSTALL INSTALLATION PRISE ALLEMANDE 230V

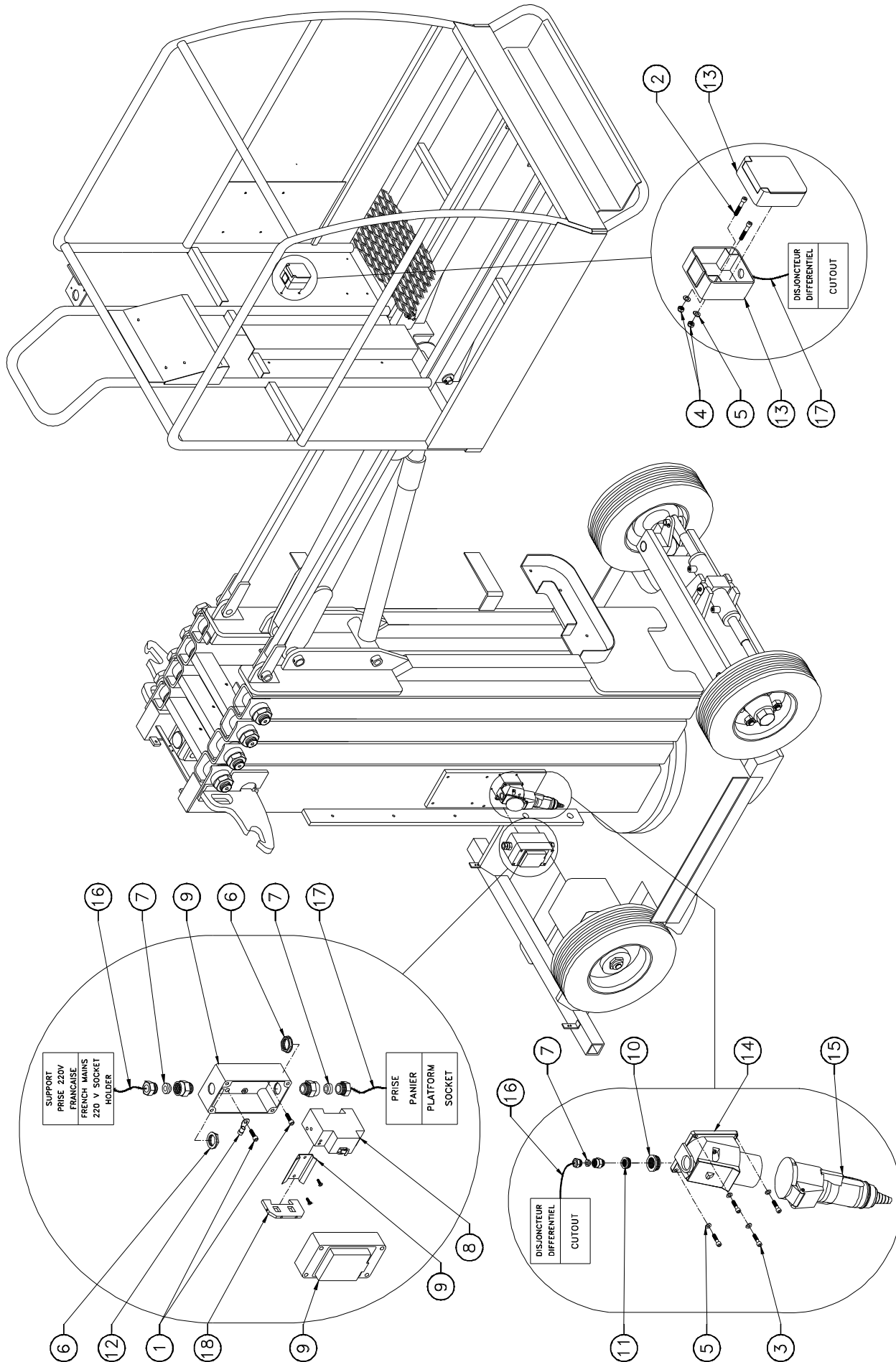

CROSS REFERENCE CHART

	Pages	Main assembly Assemblage supérieur
520014	9-2-1	SP0218
520107	9-1-1-1	SE0771
900058	9-2-1-1	520014
FL0151	6-7	
PC0452	3-2	SP0228
PC0456	3-1	SP0228
RM0090	3-2-1	PC0452
RM0091	3-2-2	PC0452
SE0765	7-1-1	SP0203
SE0766	7-2-1	SP0204
SE0767	7-3-1	SP0205
SE0771	9-1-1	SP0208
SE0803	3-2-3	PC0452
SE0804	3-2-4	PC0452
SP0202	7	
SP0203	7-1	SP0202
SP0204	7-2	SP0202
SP0205	7-3	SP0202
SP0206	7-4	SP0202
SP0208	9-1	SP0214
SP0210	2	
SP0211	4	
SP0212	10	
SP0214	9	
SP0218	9-2	SP0214
SP0219	11	
SP0221	6-1	SP0222
SP0222	6	
SP0225	5	
SP0228	3	
SP0236	6-2	SP0222
SP0237	6-3	SP0222
SP0238	6-4	SP0222
SP0239	6-5	SP0222
SP0240	6-6	SP0222
SP0241	1	
SP1105	10-1	SP0212
SP1133	8	