



MODELS TOUCAN DUO

CE



**SPARE PARTS MANUAL
MANUEL DE PIÈCES DÉTACHÉES**

U.S.A.
JLG INDUSTRIES, INC
1 JLG Drive
McConnellsburg
PA 17233-9533
Tél : (717) 485-5161
Fax : (717) 485-6417

C.E.
JLG Industries,
Kilmartin Place,
Tannochside Park
Uddingston, Scotland G71 5PH
Tel : +44(0)1698 811005
Fax : +44(0)1698 811055

AUSTRALIA
JLG INDUSTRIE
P.O Box 972
11 Bolwarra Road
Port MacQuarie N.S.W. 44
Tel : 1 (065) 811111
Fax : 1 (065) 810122

FRANCE
Delta Manlift SAS
Z.I. «Guillaume mon amy»
BP 20- 47400 TONNEINS
France
Tel : +33 553 84 85 11
Fax : +33 553 79 06 87

Updated : 06-2004

**MA0321-02
English/French**



DISTRIBUTOR STAMP / CACHET DISTRIBUTEUR

MACHINE SERIAL NUMBER :
NUMERO DE SERIE MACHINE :

Toucan Duo N° _____



Cert. N° FM 40826
Edition 06-2004
MA0321-03

SPARE PARTS

TO ORDER PARTS

IT IS ESSENTIAL TO SUPPLY THE FOLLOWING INFORMATION ON PARTS ORDERS SO THAT YOUR ORDER CAN BE PROPERLY EXPEDITED.

1. Give model and serial number of your machine. This information is found on the serial number plate mounted on the mast n°1 on the front of the platform.
2. Give complete information on the parts requested including the part number, description, and quantity.
3. Give the specific major unit for which the item is required, such as : frame, mast, cylinder, platform, control box, etc.
4. Give complete "ship-to" address and specify the exact method of shipment wanted.
5. Specify the urgency of the parts order by designating the priority (emergency or stock).

NOTE

When placing telephone order, please record with whom you spoke and date, so that follow-up telephone conversations are processed without confusion.

PIECES DETACHEES

POUR PASSER COMMANDE

AFIN QUE VOTRE COMMANDE SOIT CORRECTEMENT TRAITEE, IL EST NECESSAIRE DE FOURNIR LES INFORMATIONS SUIVANTES SUR LE BON DE COMMANDE.

1. Noter le modèle et le numéro de série de votre machine. Ces informations se trouvent sur la plaque constructeur qui est fixée sur l'avant de la machine, sur l'élément de mât n°1.
2. Noter entièrement les renseignements sur les articles en commande : référence de la pièce, description et quantité.
3. Indiquer l'unité principale pour laquelle la pièce est commandée : châssis, mât, vérin, plate-forme, boîtier de commande, etc...
4. Noter l'adresse complète du destinataire et indiquer le mode d'expédition souhaité.
5. Spécifier l'urgence des pièces commandées en indiquant leur priorité (urgence ou stock).

NOTE

Si vous passez une commande téléphonique, noter le nom de votre interlocuteur et la date afin que le suivi de votre entretien se fasse sans confusion.

TOUCAN DUO

UPPER CONTROL BOX
BOITIER HAUT
SECTION 2-2-3

PLATFORM
PANIER
SECTION 6-1-1

TABLE BOX
BOITIER TABLETTE
SECTION 2-2-5

TABLE
TABLETTE
SECTION 6-1

MAST
MAT
SECTION 5

LOWER CONTROL BOX
BOITIER BAS
SECTION 2-2-6

BOARD BOX
BOITIER CARTE
SECTION 2-2-4

DECALS
AUTOCOLLANTS
SECTION 7

COVERS
CAPOTS
SECTION 1

STEERING WHEEL
ROUE DIRECTRICE
SECTION 2-2-6

FRAME
CHASSIS
SECTION 4

CHARGER
CHARGEUR
SECTION 4

BATTERY
BATTERIE
SECTION 4

DRIVING WHEEL
ROUE MOTRICE
SECTION 4



TABLE OF CONTENTS		TABLE DES MATIERES	
COVERS INSTALL	1	INSTALLATION CAPOTS	1
ELECTRICAL INSTALL	2	INSTALLATION ELECTRIQUE	2
POWER CIRCUIT	2-1	CIRCUIT DE PUISSANCE	2-1
CONTROL CIRCUIT	2-2	CIRCUIT DE COMMANDE	2-2
MATE-N-LOK CONNECTORS	2-2-1	CONNECTEURS MATE-N-LOK	2-2-1
CONNECTORS ON HARNESS ASSEMBLY	2-2-2	CONNECTEURS SUR FAISCEAUX	2-2-2
UPPER CONTROL BOX ASSEMBLY	2-2-3	ASSEMBLAGE BOITIER HAUT	2-2-3
BOARD BOX ASSEMBLY	2-2-4	ASSEMBLAGE BOITIER CARTE	2-2-4
TABLE BOX ASSEMBLY	2-2-5	ASSEMBLAGE BOITIER TABLETTE	2-2-5
LOWER CONTROL BOX ASSEMBLY	2-2-6	ASSEMBLAGE BOITIER BAS	2-2-6
LOWER CONTROL BOX WITH HOURMETER	2-2-7	BOITIER BAS AVEC HORAMETRE	2-2-7
MASTS ON FRAME INSTALL	3	INSTALLATION MATS SUR CHASSIS	3
FRAME INSTALL	4	INSTALLATION CHASSIS	4
CHARGER CONNECTOR	4-1	PRISE CHARGEUR	4-1
COMPLETE POWER UNIT 1.25cc	4-2	CENTRALE COMPLETE 1.25cm ³	4-2
MASTS INSTALL	5	INSTALLATION MATS	5
MAST 1 ASSEMBLY	5-1	ASSEMBLAGE MAT 1	5-1
MAST CYLINDER	5-1-1	VERIN DE MAT	5-1-1
MAST 2 ASSEMBLY	5-2	ASSEMBLAGE MAT 2	5-2
MAST 3 ASSEMBLY	5-3	ASSEMBLAGE MAT 3	5-3
MAST 4 ASSEMBLY	5-4	ASSEMBLAGE MAT 4	5-4
PLATFORM AND TABLE INSTALL	6	INSTALLATION PANIER ET TABLETTE	6
PLATFORM AND TABLE ASSEMBLY	6-1	ASSEMBLAGE PANIER ET TABLETTE	6-1
PLATFORM ASSEMBLY	6-1-1	ASSEMBLAGE PANIER	6-1-1
DECALS INSTALL	7	INSTALLATION AUTOCOLLANTS	7
CROSS REFERENCE CHART	LAST PAGE	TABLEAU DE CORRESPONDANCE	DERNIERE PAGE

SPARE PARTS
PIECES DETACHEES

SECTION 1

COVERS INSTALL
INSTALLATION CAPOTS



COVERS INSTALL INSTALLATION CAPOTS

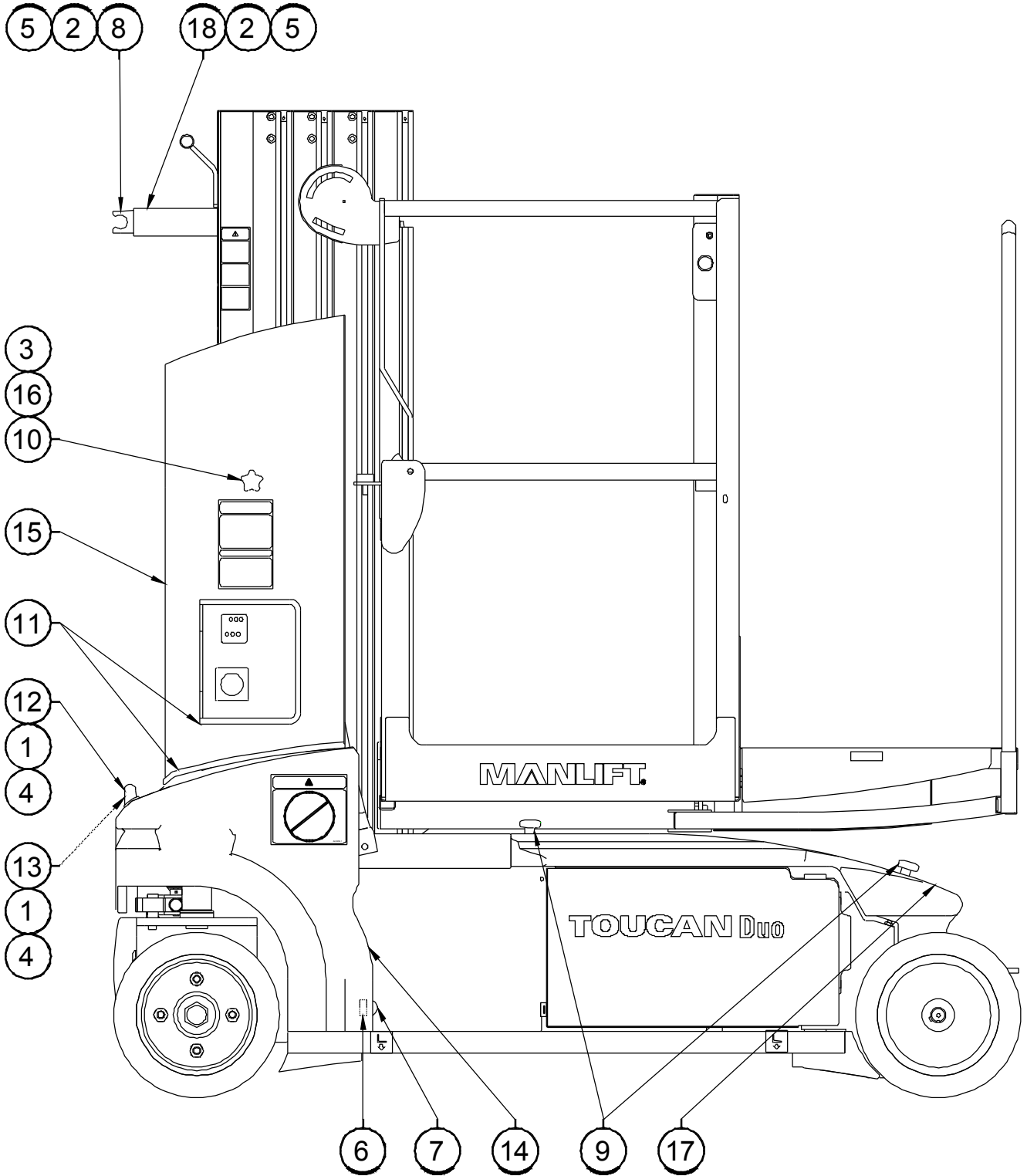

SPARE PARTS
PIECES DETACHEES

SECTION 2

ELECTRICAL INSTALL
INSTALLATION ELECTRIQUE



POWER CIRCUIT CIRCUIT DE PUISSANCE

**GRAISSER LES DEUX COSSES DE CHAQUE BATTERIE APRES LES AVOIR SERREES
GREASE BOTH TERMINALS ON EACH BATTERY AFTER THEY ARE TIGHTENED**

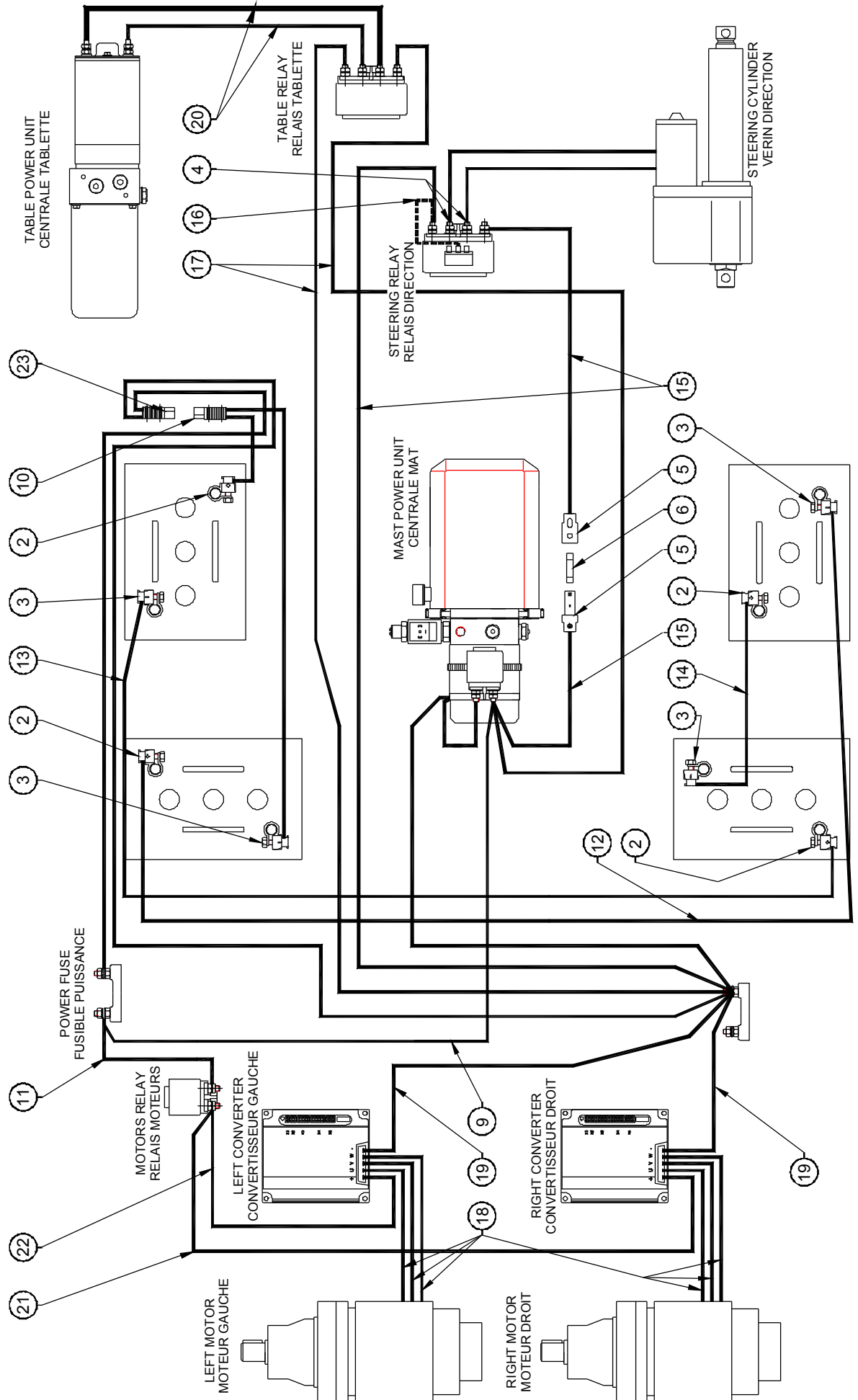

ISSUE DATE : 21/06/04

POWER ELECTRICAL INSTALL

ISSUE REL :

ASSEMBLY N° : PC0378 REV :
 N° ENSEMBLE :

**INSTALLATION ELECTRIQUE DE
 PUISSANCE**

1/1

DET REP	PART NUMBER REF.	SEE VIEW VOIR VUE	DESCRIPTION		R E V	QTY QTE
1			NOT REQUIRED	NON REQUIS		
2	250028		BATTERIE TERMINAL +	COSSE + BATTERIE		4
3	250029		BATTERIE TERMINAL -	COSSE - BATTERIE		4
4	250096		M06 EYELET TERMINAL 4-6mm²	COSSE A ŒIL ISOLEE M6 - 4-6mm²		2
5	260007		FUSE HOLDER	PORTE FUSIBLE		1
6	260175		FUSE 16A	FUSIBLE 16A		1
7			NOT REQUIRED	NON REQUIS		
8			NOT REQUIRED	NON REQUIS		
9	PC0088		CABLE ASSEMBLY	CABLE ELECTRIQUE		1
10	PC0092		CABLE ASSEMBLY	CABLE ELECTRIQUE		1
11	PC0093		CABLE ASSEMBLY	CABLE ELECTRIQUE		1
12	PC0094		CABLE ASSEMBLY	CABLE ELECTRIQUE		1
13	PC0095		CABLE ASSEMBLY	CABLE ELECTRIQUE		1
14	PC0096		CABLE ASSEMBLY	CABLE ELECTRIQUE		1
15	PC0365		HARNESS ASSY-FRONT OF FRAME	FAISCEAU AVANT CHASSIS		1
16	PC0368		NEGATIVE BATTERY JUMPER	PONT NEGATIF BATTERIE		1
17	PC0369		CABLE ASSEMBLY	CABLE ELECTRIQUE		1
18	PC0370		CABLE ASSEMBLY	CABLE ELECTRIQUE		6
19	PC0371		CABLE ASSEMBLY	CABLE ELECTRIQUE		2
20	PC0372		CABLE ASSEMBLY	CABLE ELECTRIQUE		2
21	PC0373		CABLE ASSEMBLY	CABLE ELECTRIQUE		1
22	PC0374		CABLE ASSEMBLY	CABLE ELECTRIQUE		1
23	PC0375		CABLE ASSEMBLY	CABLE ELECTRIQUE		1

CONTROL CIRCUIT CIRCUIT DE COMMANDE

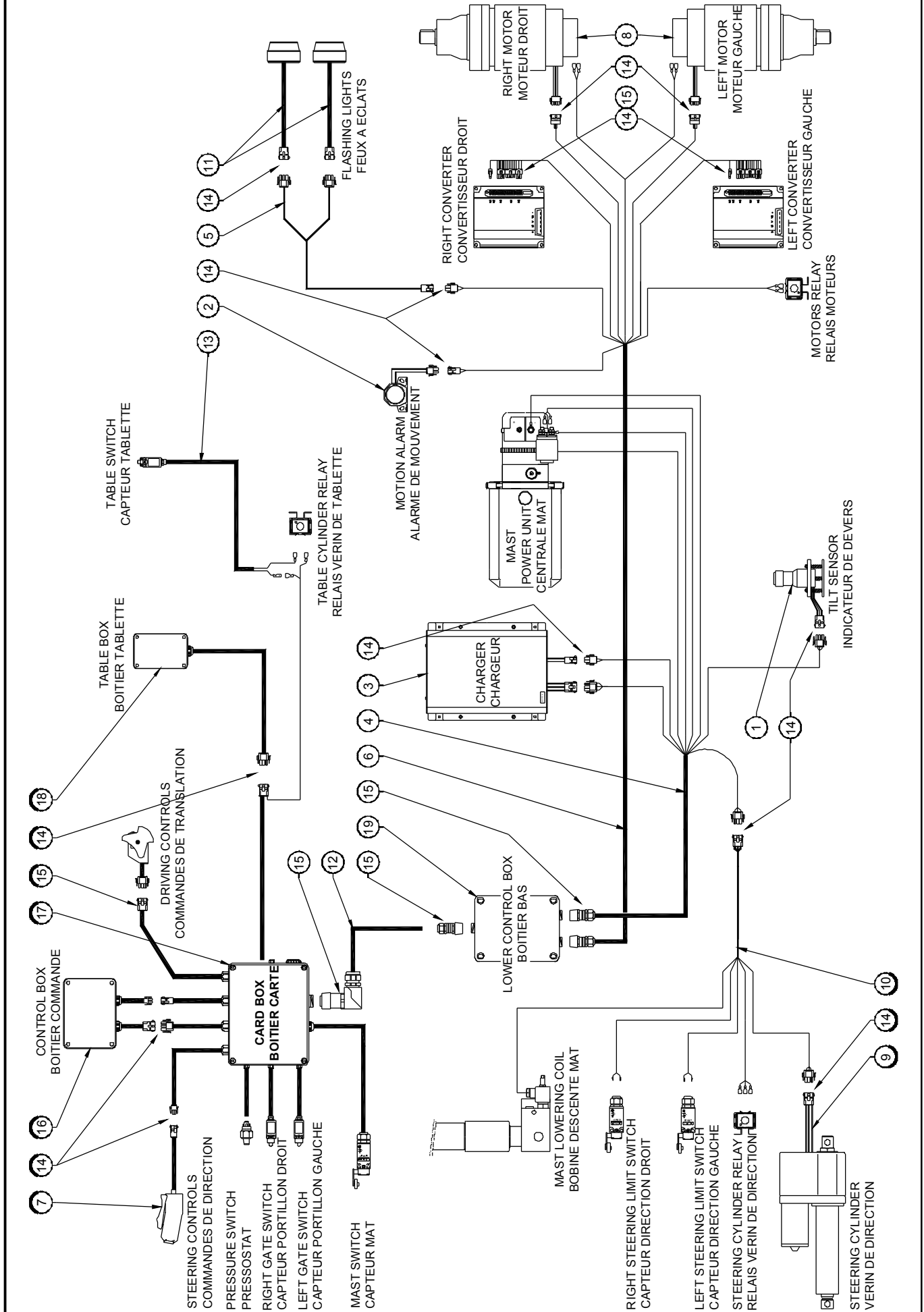

ISSUE DATE : 16/03/04

CONTROL CIRCUIT

ISSUE REL :

CIRCUIT DE COMMANDE

ASSEMBLY N° : PC0382 REV :
 N° ENSEMBLE :

1/1

DET REP	PART NUMBER REF.	SEE VIEW VOIR VUE	DESCRIPTION		R E V	QTY QTE
1	PC0203		HARNES ASSEMBLY-TILT SENSOR	CABLAGE DETECTEUR DE DEVERS		1
2	PC0204		HARNES ASSEMBLY-MOTION ALARM	CABLAGE ALARME DE MOUVEMENT		1
3	PC0205		HARNES ASSEMBLY-CHARGER	FAISCEAU CHARGEUR		1
4	PC0211		HARNES ASSEMBLY-POWER UNIT	CABLAGE CENTRALE		1
5	PC0355		HARNES ASSEMBLY-FLASHING LIGHTS	FAISCEAU FEUX A ECLATS		1
6	PC0356		HARNES ASSEMBLY-DRIVE DEVICE	CABLAGE MOTORISATION		1
7	PC0362		HARNES ASSY-STEERING CONTROLS	FAISCEAU COMMANDES DE DIRECTION		1
8	PC0363		HARNES ASSEMBLY-DRIVE MOTOR	FAISCEAU MOTEUR DE ROUE		2
9	PC0364		HARNES ASSY-STEERING CYLINDER	FAISCEAU VERIN DE DIRECTION		1
10	PC0365		HARNES ASSY-FRONT OF FRAME	FAISCEAU AVANT CHASSIS		1
11	PC0366		HARNES ASSEMBLY-FLASHING LIGHT	FAISCEAU FEU A ECLATS		2
12	PC0367		LOWER CONTROL BOX / CARD BOX LINK	LIAISON BOITIER BAS / BOITIER CARTE		1
13	PC0376		HARNES ASSEMBLY-TABLE SWITCH	FAISCEAU CAPTEUR TABLETTE		1
14		RM0090	MATE-N-LOK CONNECTORS	CONNECTEURS MATE-N-LOK		x
15		RM0091	CONNECTORS ON HARNES ASSEMBLY	CONNECTEURS SUR FAISCEAUX		x
16		SP0802	UPPER CONTROL BOX ASSEMBLY	ASSEMBLAGE BOITIER HAUT		1
17		SP0803	BOARD BOX ASSEMBLY	ASSEMBLAGE BOITIER CARTE		1
18		SP0804	TABLE BOX ASSEMBLY	ASSEMBLAGE BOITIER TABLETTE		1
19		SP0805	LOWER CONTROL BOX ASSEMBLY	ASSEMBLAGE BOITIER BAS		1
19		SP0883	LOWER CONTROL BOX WITH HOURMETE	BOITIER BAS AVEC HORAMETRE		1

MATE-N-LOK CONNECTORS CONNECTEURS MATE-N-LOK

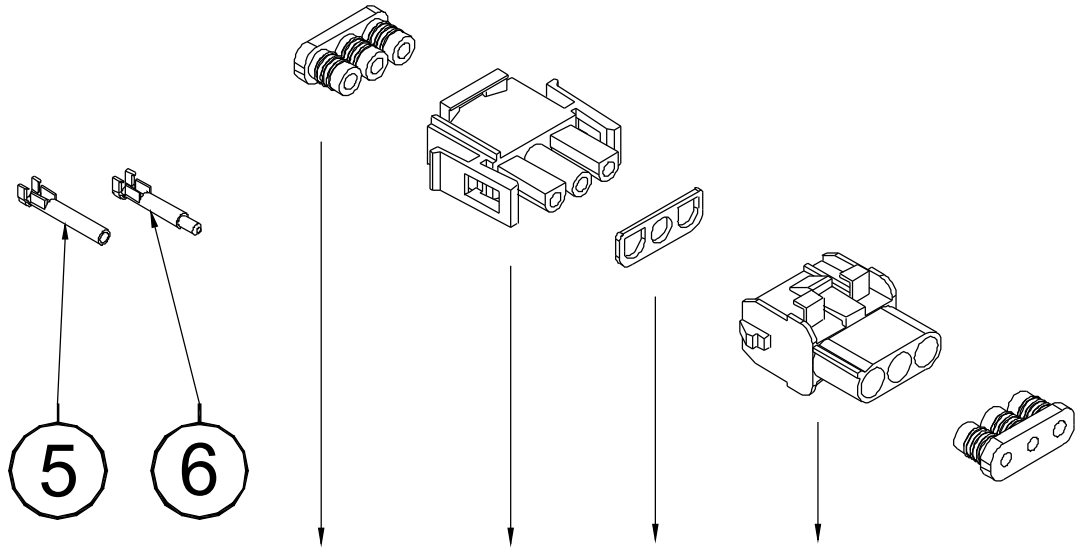

	26	23	25	24
	10	7	9	8
	14	11	13	12
	18	15	17	16
	4	1	3	2
	22	19	21	20

ISSUE DATE : 28/04/03

MATE-N-LOK CONNECTORS

ISSUE REL :

ASSEMBLY N° :
N° ENSEMBLE :

RM0090 REV :

CONNECTEURS MATE-N-LOK

1/1

DET REP	PART NUMBER REF.	SEE VIEW VOIR VUE	DESCRIPTION		R E V	QTY QTE
1	210029		9 POSITIONS PLUG HOUSING "MNL"	CONNECTEUR MALE 9 COSSES "MNL"		
2	210030		9 POSITIONS CAP HOUSING "MNL"	CONNECTEUR FEMELLE 9 COSSES "MNL"		
3	210031		9 POSITIONS INTERFACE SEAL	JOINT INTERFACE CONNECTEUR 9 CTS		
4	210032		9 POSITIONS WIRE SEAL	JOINT ARRIERE CONNECTEUR 9 CTS		
5	210033		SOCKET CONTACT "MATE-N-LOK"	CONTACT FEMELLE "MATE-N-LOK"		
6	210034		PIN CONTACT "MATE-N-LOK"	CONTACT MALE "MATE-N-LOK"		
7	250140		3 POSITIONS "MNL" PLUG HOUSING	CONNECTEUR MALE 3 CONTACTS "MNL"		
8	250141		3 POSITIONS "MNL" CAP HOUSING	CONNECTEUR FEMELLE 3 CTS "MNL"		
9	250143		3 POSITIONS INTERFACE SEAL	JOINT INTERFACE CONNECTEUR 3 CTS		
10	250144		3 POSITIONS WIRE SEAL	JOINT ARRIERE CONNECTEUR 3 CTS		
11	250145		4 POSITIONS "MNL" PLUG HOUSING	CONNECTEUR MALE 4 CONTACTS "MNL"		
12	250146		4 POSITIONS "MNL" CAP HOUSING	CONNECTEUR FEMELLE 4 CTS "MNL"		
13	250148		4 POSITIONS INTERFACE SEAL	JOINT INTERFACE CONNECTEUR 4 CTS		
14	250149		4 POSITIONS WIRE SEAL	JOINT ARRIERE CONNECTEUR 4 CTS		
15	250150		6 POSITIONS "MNL" PLUG HOUSING	CONNECTEUR MALE 6 CONTACTS "MNL"		
16	250151		6 POSITIONS "MNL" CAP HOUSING	CONNECTEUR FEMELLE 6 CTS "MNL"		
17	250153		6 POSITIONS INTERFACE SEAL	JOINT INTERFACE CONNECTEUR 6 CTS		
18	250154		6 POSITIONS WIRE SEAL	JOINT ARRIERE CONNECTEUR 6 CTS		
19	250155		12 POSITIONS "MNL" PLUG HOUSING	CONNECTEUR MALE 12 CONTACTS "MNL"		
20	250156		12 POSITIONS "MNL" CAP HOUSING	CONNECTEUR FEMELLE 12 CTS "MNL"		
21	250158		12 POSITIONS INTERFACE SEAL	JOINT INTERFACE CONNECTEUR 12 CTS		
22	250159		12 POSITIONS WIRE SEAL	JOINT ARRIERE CONNECTEUR 12 CTS		
23	250193		2 POSITIONS "MNL" PLUG HOUSING	CONNECTEUR MALE 2 CONTACTS "MNL"		
24	250194		2 POSITIONS "MNL" CAP HOUSING	CONNECTEUR FEMELLE 2 CTS "MNL"		
25	250195		2 POSITIONS INTERFACE SEAL	JOINT INTERFACE CONNECTEUR 2 CTS		
26	250196		2 POSITIONS WIRE SEAL	JOINT ARRIERE CONNECTEUR 2 CTS		

CONNECTORS ON HARNESS ASSEMBLY CONNECTEURS SUR FAISCEAUX

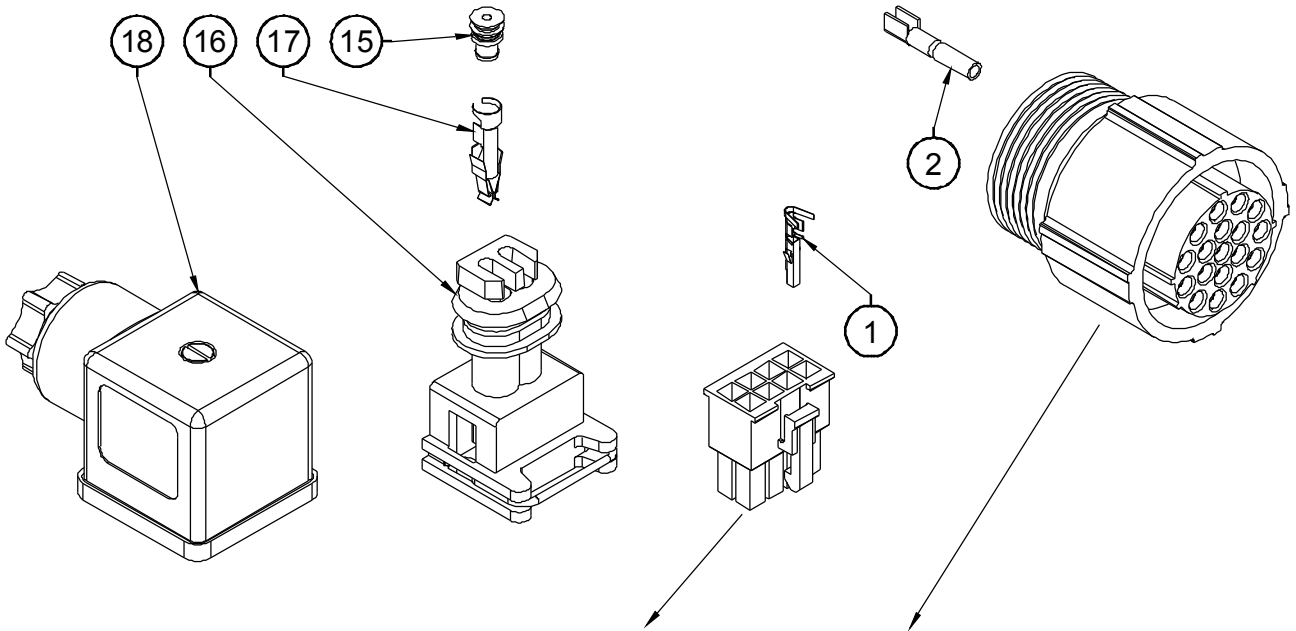

Number of pins Nombre de contacts	PART NUMBER / REP		GLAND / PE	
	MOLEX	FCI		
2	(3)			
4	(4)			
6	(5)			
8	(6)		180°	90°
9		(12)	(22)	
10	(7)			
12	(8)			
14	(9)			
16	(10)			
18	(24)	(13)	(21)	(23)
22	(25)			
24	(11)			
26		(14)	(20)	(19)

CONNECTORS ON HARNESS ASSEMBLY

ISSUE DATE : 12/05/03

ISSUE REL :

CONNECTEURS SUR FAISCEAUX

ASSEMBLY N° : RM0091 REV :
N° ENSEMBLE :

1/1

DET REP	PART NUMBER REF.	SEE VIEW VOIR VUE	DESCRIPTION		R E V	QTY QTE
1	250190		SOCKET CONTACT "MOLEX MINI-FIT"	CONTACT FEMELLE "MOLEX MINI-FIT"		
2	260130		SOCKET CONTACT	CONTACT A SERTIR FEMELLE		
3	250206		2 POS. "MOLEX MINI-FIT" PLUG HOUSING	CONNECTEUR "MOLEX MINI-FIT" 2 CTS		
4	250199		4 POS. "MOLEX MINI-FIT" PLUG HOUSING	CONNECTEUR "MOLEX MINI-FIT" 4 CTS		
5	250200		6 POS. "MOLEX MINI-FIT" PLUG HOUSING	CONNECTEUR "MOLEX MINI-FIT" 6 CTS		
6	250189		8 POS. "MOLEX MINI-FIT" PLUG HOUSING	CONNECTEUR "MOLEX MINI-FIT" 8 CTS		
7	250201		10 POS. "MOLEX MINI-FIT" PLUG HOUSING	CONNECTEUR "MOLEX MINI-FIT" 10 CTS		
8	250202		12 POS. "MOLEX MINI-FIT" PLUG HOUSING	CONNECTEUR "MOLEX MINI-FIT" 12 CTS		
9	250203		14 POS. "MOLEX MINI-FIT" PLUG HOUSING	CONNECTEUR "MOLEX MINI-FIT" 14 CTS		
10	250204		16 POS. "MOLEX MINI-FIT" PLUG HOUSING	CONNECTEUR "MOLEX MINI-FIT" 16 CTS		
11	250205		24 POS. "MOLEX MINI-FIT" PLUG HOUSING	CONNECTEUR "MOLEX MINI-FIT" 24 CTS		
12	260177		9 POSITIONS SOCKET HOUSING	CONNECTEUR 9 CONTACTS		
13	260168		18 POSITIONS SOCKET HOUSING	CONNECTEUR 18 CONTACTS		
14	260128		26 POSITIONS SOCKET HOUSING	CONNECTEUR 26 CONTACTS		
15	260132		WIRE SEAL	JOINT DE CONNECTEUR		
16	260136		AMP TIMER CAP HOUSING	CONNECTEUR AMP TIMER		
17	260137		RECEPTACLE CONTACT	CONTACT		
18	900087		CONNECTOR DIN43650-A	CONNECTEUR DIN43650-A		
19	210020		90° CABLE GLAND N°29	PRESSE ETOUPE COUDE N°29		
20	260129		CABLE GLAND N°29	PRESSE ETOUPE N°29		
21	260169		CABLE GLAND N°21	PRESSE ETOUPE N°21		
22	260170		CABLE GLAND N°16	PRESSE ETOUPE N°16		
23	260221		90° CABLE GLAND N°21	PRESSE ETOUPE COUDE N°21		
24	250216		18 POS. "MOLEX MINI-FIT" PLUG HOUSING	CONNECTEUR "MOLEX MINI-FIT" 18 CTS		
25	250217		22 POS. "MOLEX MINI-FIT" PLUG HOUSING	CONNECTEUR "MOLEX MINI-FIT" 22 CTS		

UPPER CONTROL BOX ASSEMBLY ASSEMBLAGE BOITIER HAUT

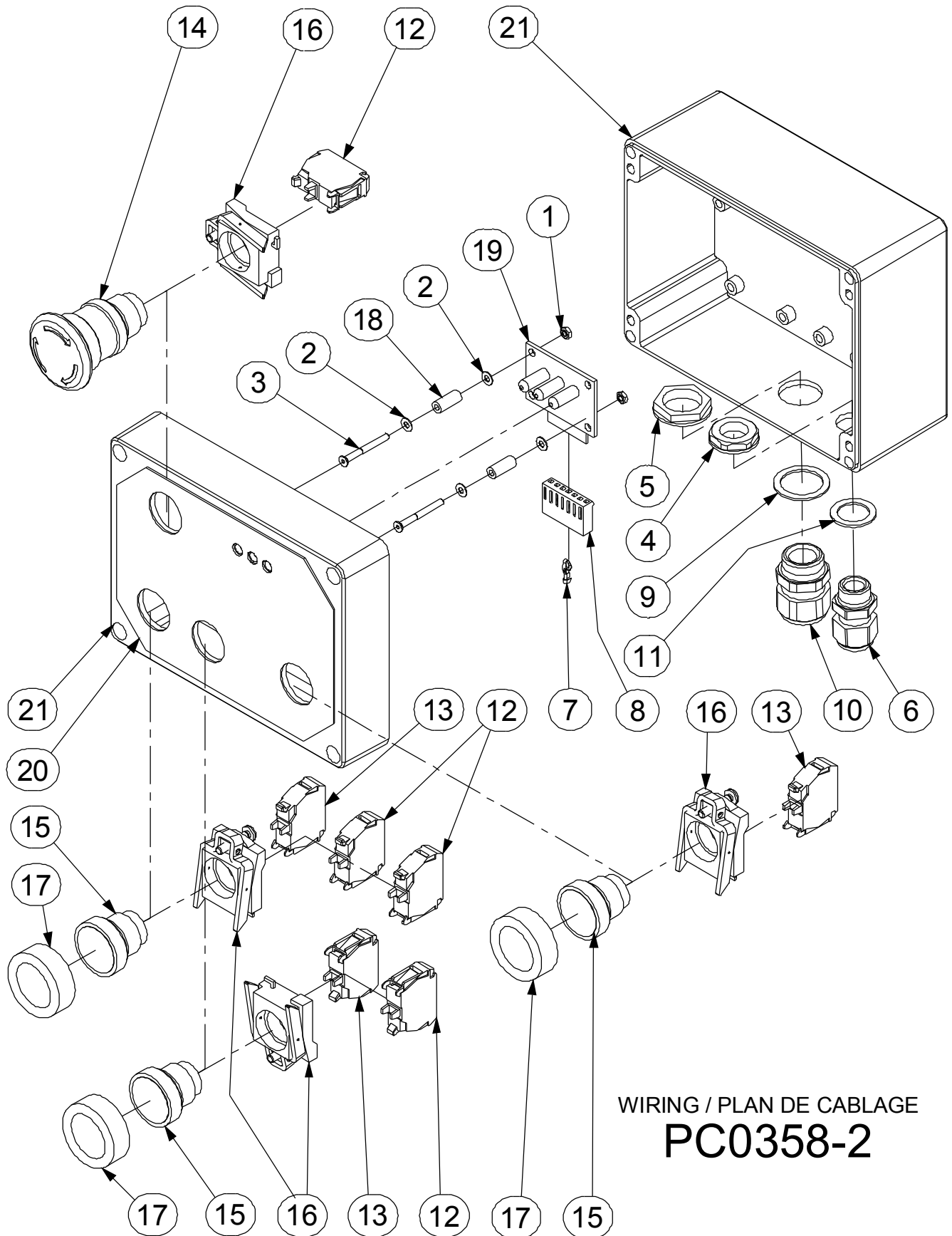

WIRING / PLAN DE CABLAGE
PC0358-2

ISSUE DATE : 22/09/03

UPPER CONTROL BOX ASSEMBLY

ISSUE REL :

ASSEMBLAGE BOITIER HAUT

ASSEMBLY N° :
 N° ENSEMBLE : SP0802 REV :

1/1

DET REP	PART NUMBER REF.	SEE VIEW VOIR VUE	DESCRIPTION		R E V	QTY
						QTE
1	110024		M03 GR. 8.8 LOCK NUT	ECROU FREIN M03 8.8 BI		2
2	120023		M03 LOCK WASHER	RONDELLE CONTACT M03 BI		4
3	130052		M03x30 8.8 COUNTERSUNK HEAD M. S.	VIS FHC M03x30 8.8 BI FT		2
4	210009		GLAND N°9 NUT	ECROU DE PRESSE ETOUPE N°9		1
5	210011		GLAND N°13 NUT	ECROU DE PRESSE ETOUPE N°13		1
6	210017		GLAND N°9	PRESSE ETOUPE N°9		1
7	210038		SOCKET CONTACT MOLEX	COSSE FEMELLE MOLEX		5
8	210047		7 POS. MOLEX KK 3.96 CAP HOUSING	CONNECTEUR 7 COSSES MOLEX KK 3.96		1
9	210057		N°13 GLAND SEAL	JOINT DE PRESSE ETOUPE N°13		1
10	210062		GLAND N°13 Ø5 IP65	PRESSE ETOUPE N°13 Ø5 IP65		1
11	210063		N°9 GLAND SEAL	JOINT DE PRESSE ETOUPE N°9		1
12	240057		NC CONTACT BLOCK	CONTACT NF		4
13	240058		NO CONTACT BLOCK	CONTACT NO		3
14	240060		TURN TO RELEASE KNOB	BOUTON D'ARRET D'URGENCE 1/4 TOUR		1
15	240061		PUSH BUTTON	BOUTON POUSSOIR		3
16	240076		CONTACT BLOCK HOLDER	EMBASE CONTACT		4
17	240082		PUSH BUTTON CAP	CAPUCHON D'ETANCHEITE		3
18	250184		Ø 3 lg 14 PLASTIC SPACER	ENTRETOISE PVC Ø 3 lg 14		2
19	290042		DISPLAY ELECTRONIC BOARD	CARTE ELECTRONIQUE D'AFFICHAGE		1
20	AU1723		UPPER CONTROL BOX DECAL	AUTOCOLLANT BOITIER HAUT		1
21	SD0662		DRILLED ELECTRICAL BOX	BOITIER ELECTRIQUE PERCE		1

BOARD BOX ASSEMBLY ASSEMBLAGE BOITIER CARTE

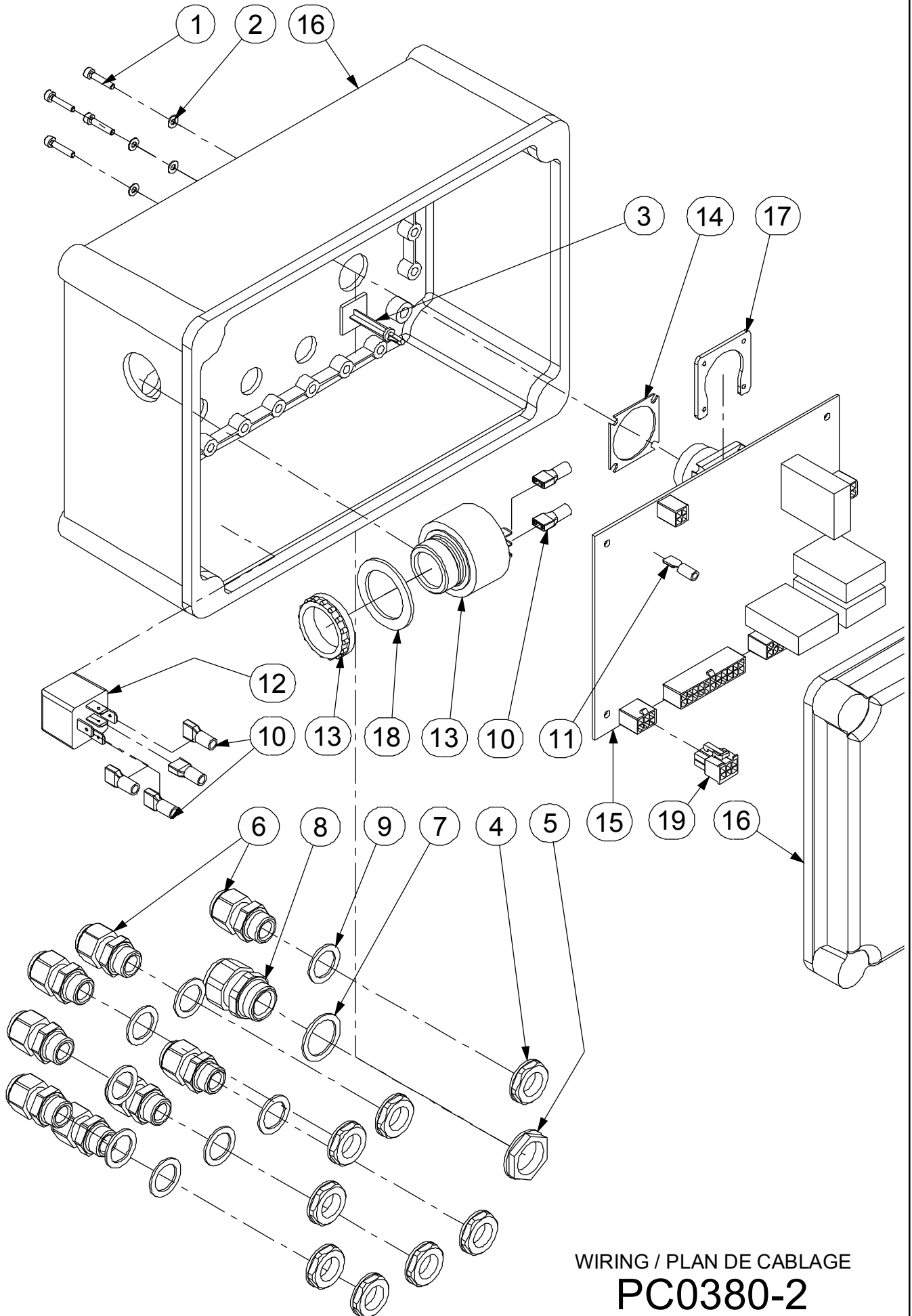

WIRING / PLAN DE CABLAGE
PC0380-2

ISSUE DATE : 22/09/03

BOARD BOX ASSEMBLY

ISSUE REL :

ASSEMBLY N° : SP0803 REV :
 N° ENSEMBLE :

ASSEMBLAGE BOITIER CARTE

1/1

DET REP	PART NUMBER REF.	SEE VIEW VOIR VUE	DESCRIPTION		R E V	QTY QTE
1	000091		M03x16 8.8 SOCKET HEAD MACH SCREW	VIS CHC M03x16 8.8 BI FT		4
2	120023		M03 LOCK WASHER	RONDELLE CONTACT M03 BI		4
3	190055		ADHESIVE BRACKET SUPPORT	ENTRETOISE SUPPORT CARTE		4
4	210009		GLAND N°9 NUT	ECROU DE PRESSE ETOUPE N°9		8
5	210011		GLAND N°13 NUT	ECROU DE PRESSE ETOUPE N°13		1
6	210017		GLAND N°9	PRESSE ETOUPE N°9		8
7	210057		N°13 GLAND SEAL	JOINT DE PRESSE ETOUPE N°13		1
8	210062		GLAND N°13 Ø5 IP65	PRESSE ETOUPE N°13 Ø5 IP65		1
9	210063		N°9 GLAND SEAL	JOINT DE PRESSE ETOUPE N°9		8
10	250027		BLUE RECEPTACLE TER. 6.3 - 1.5-2.5mm ²	COSSE FEM. 6.3 BLEUE 6.3 - 1.5-2.5mm ²		10
11	250060		RECEPTACLE TERMINAL 4.8 - 0.25-1 mm ²	COSSE ISOLEE 4.8 mm 0.25-1 mm ²		7
12	260019		1RT 24V RELAY	RELAIS 24 V 1RT		1
13	260045		BUZZER 24 V	BUZZER 24 V		1
14	260167		18 POSITIONS CHASSIS PLUG GASKET	JOINT CONNECTEUR 18 CONTACTS		1
15	290044		UPPER CONTROL BOX BOARD	CARTE BOITIER HAUT		1
16	SD0661		DRILLED ELECTRICAL BOX	BOITIER ELECTRIQUE PERCE		1
17	ST1935		CONNECTOR PLATE	CONTRE PLAQUE CONNECTEUR		1
18	ST2063		BUZZER SEAL	JOINT BUZZER		1
19		RM0091	CONNECTORS ON HARNESS ASSEMBLY	CONNECTEURS SUR FAISCEAUX		1

TABLE BOX ASSEMBLY ASSEMBLAGE BOITIER TABLETTE

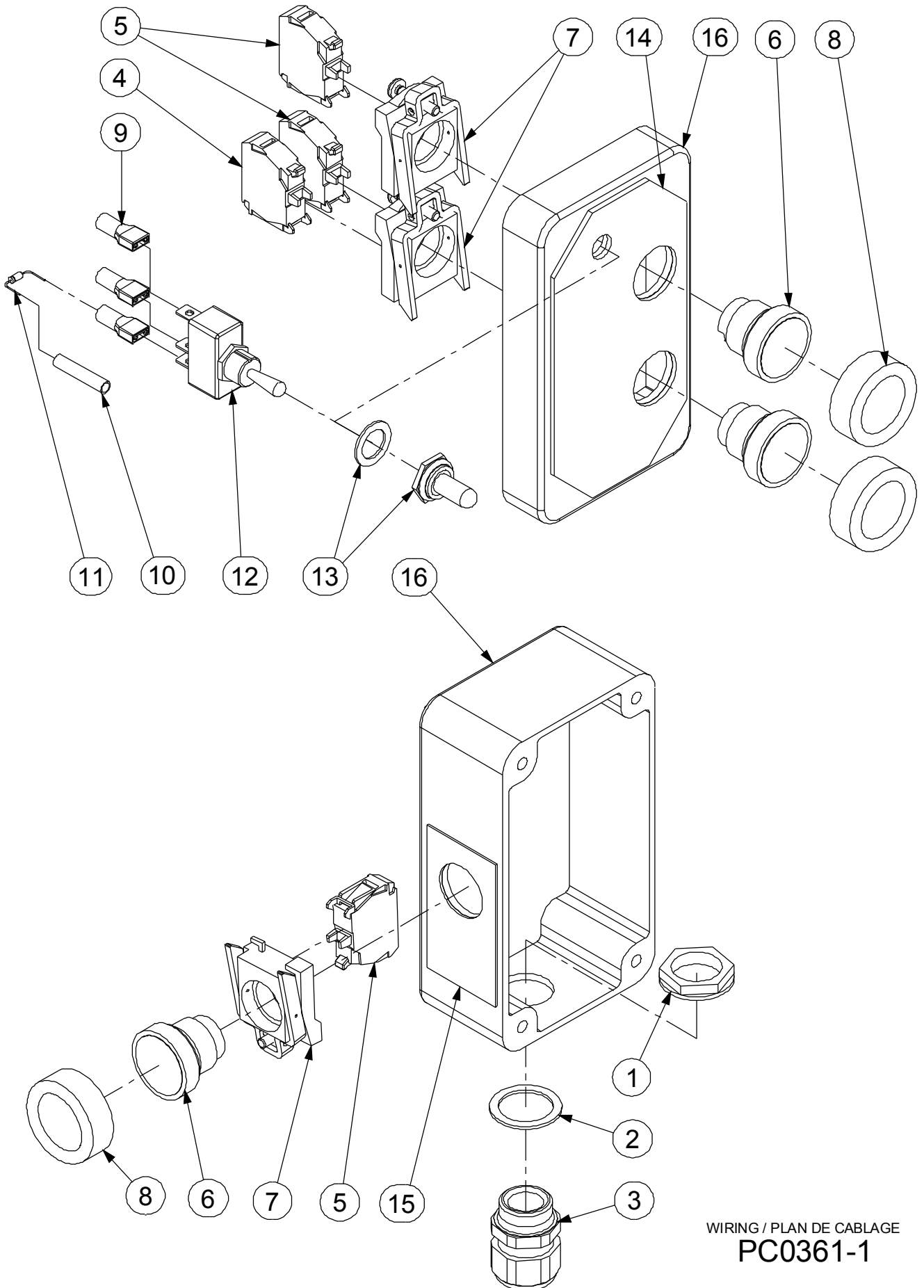

WIRING / PLAN DE CABLAGE
PC0361-1

LOWER CONTROL BOX ASSEMBLY ASSEMBLAGE BOITIER BAS

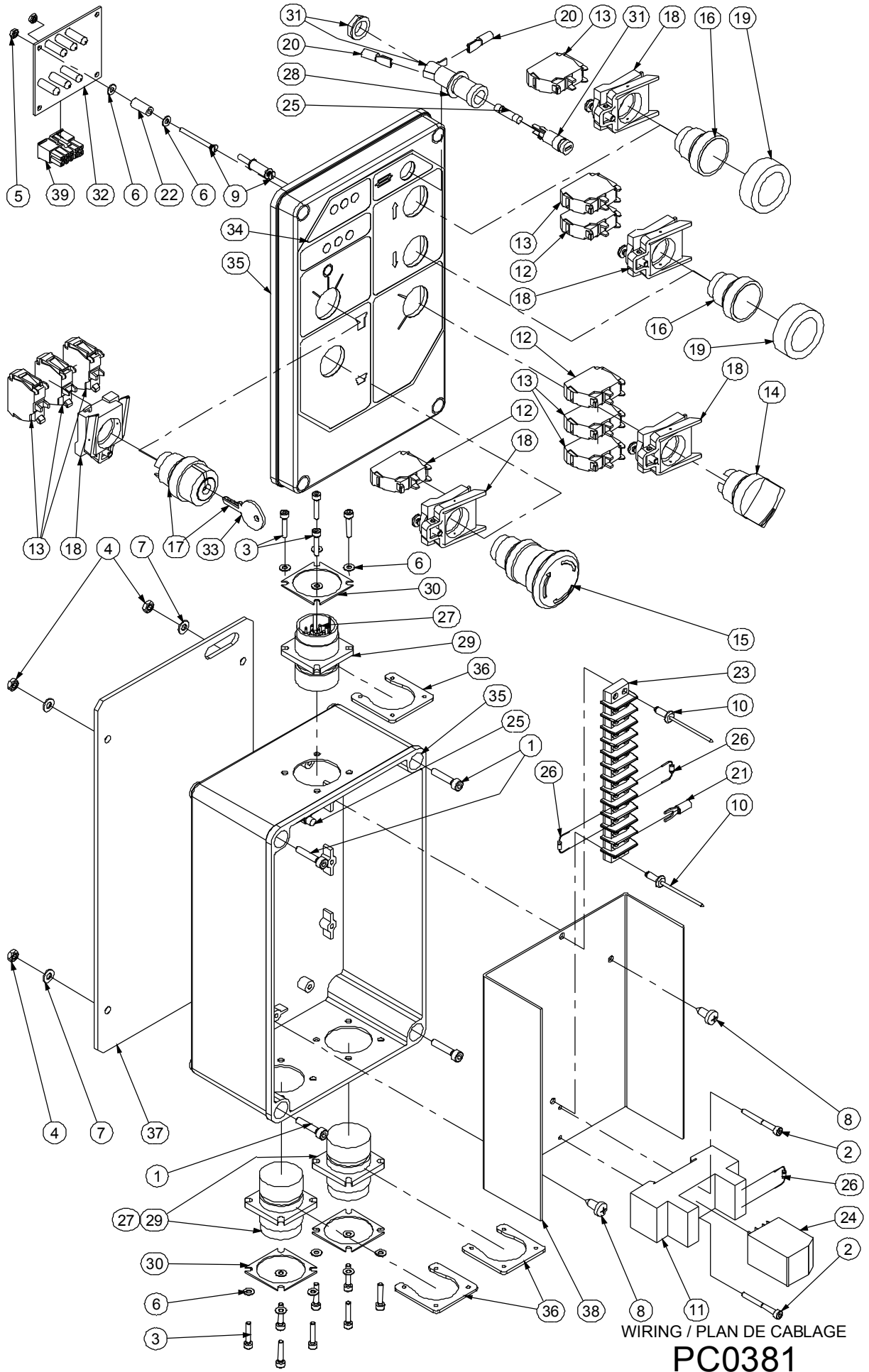

WIRING / PLAN DE CABLAGE
PC0381

ISSUE DATE : 22/09/03

LOWER CONTROL BOX ASSEMBLY

ISSUE REL :

ASSEMBLAGE BOITIER BASASSEMBLY N° : SP0805 REV :
N° ENSEMBLE :

1/2

DET REP	PART NUMBER REF.	SEE VIEW VOIR VUE	DESCRIPTION		R E V	QTY QTE
1	000020		M04x20 8.8 SOCKET HEAD MACH SCREW	VIS CHC M04x20 8.8 BI FT		4
2	000052		M03x30 8.8 SOCKET HEAD MACH SCREW	VIS CHC M03x30 8.8 BR FT		2
3	000091		M03x16 8.8 SOCKET HEAD MACH SCREW	VIS CHC M03x16 8.8 BI FT		12
4	110001		M04 GR. 8.8 LOCK NUT	ECROU FREIN M4 8.8 BI		4
5	110024		M03 GR. 8.8 LOCK NUT	ECROU FREIN M03 8.8 BI		2
6	120023		M03 LOCK WASHER	RONDELLE CONTACT M03 BI		16
7	120024		M04 LOCK WASHER	RONDELLE CONTACT M04 BI		4
8	130007		Ø4.8x13 LG SHEET METAL SCREW	VIS AUTOTARAUDEUSE Ø4.8-13 BI		2
9	130052		M03x30 8.8 COUNTERSUNK HEAD M. S.	VIS FHC M03x30 8.8 BI FT		2
10	180002		Ø4x10 POP RIVET	RIVET POP Ø4x10		2
11	240019		4RT RELAY BASE	EMBASE DE RELAIS 4RT		1
12	240057		NC CONTACT BLOCK	CONTACT NF		3
13	240058		NO CONTACT BLOCK	CONTACT NO		7
14	240059		2 POSITIONS SELECTOR	SELECTEUR 2 POSITIONS		1
15	240060		TURN TO RELEASE KNOB	BOUTON D'ARRET D'URGENCE 1/4 TOUR		1
16	240061		PUSH BUTTON	BOUTON POUSSOIR		2
17	240066		3 POSITIONS KEY SELECTOR	SELECTEUR A CLE 3 POSITIONS		1
18	240076		CONTACT BLOCK HOLDER	EMBASE CONTACT		5
19	240082		PUSH BUTTON CAP	CAPUCHON D'ETANCHEITE		2
20	250060		RECEPTACLE TERMINAL 4.8 - 0.25-1 mm ²	COSSE ISOLEE 4.8 mm 0.25-1 mm ²		2
21	250085		M04 FORK TERMINAL 0.5-1mm ²	COSSE FOURCHE M04 - 0.5-1mm ²		18
22	250184		Ø 3 lg 14 PLASTIC SPACER	ENTRETOISE PVC Ø 3 lg 14		2
23	250191		12 PTS TERMINAL BLOCK	BARETTE DE CONNEXION 12 PTS		1
24	260042		4RT RELAY	RELAIS 4RT		1
25	260074		5A QUICK ACTING FUSE	FUSIBLE RAPIDE 5A		2
26	260093		1A DIODE	DIODE 1A		3
27	260131		PIN CONTACT	CONTACT MALE		54
28	260134		TOGGLE SWITCH GASKET	JOINT D'INVERSEUR		1
29	260166		18 POSITIONS CHASSIS PLUG HOUSING	EMBASE CONNECTEUR 18 CONTACTS		3
30	260167		18 POSITIONS CHASSIS PLUG GASCKET	JOINT CONNECTEUR 18 CONTACTS		3
31	260224		FUSE HOLDER	PORTE FUSIBLE		1
32	290051		6 LEDS BATTERY BOARD	CARTE BATTERIE 6 LEDS		1
33	910003		KEY N°421	CLE N°421		1
34	AU1722		LOWER CONTROL BOX DECAL	AUTOCOLLANT BOITIER BAS		1
35	SD0663		DRILLED ELECTRICAL BOX	BOITIER ELECTRIQUE PERCE		1
36	ST1935		CONNECTOR PLATE	CONTRE PLAQUE CONNECTEUR		3
37	ST2743		LOWER CONTROL BOX SUPPORT SHIELD	TOLE SUPPORT BOITIER BAS		1

LOWER CONTROL BOX ASSEMBLY

ASSEMBLAGE BOITIER BAS

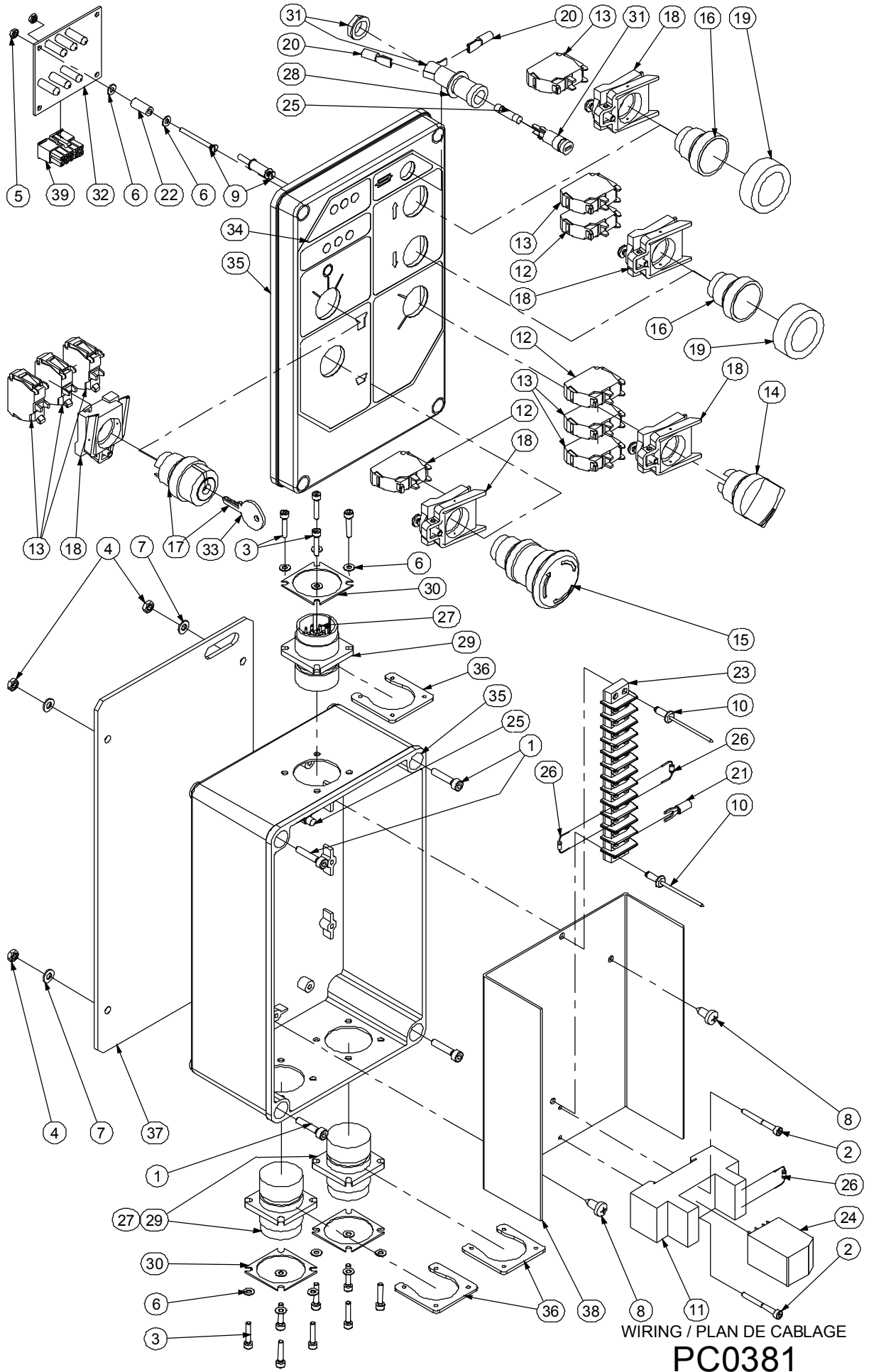

WIRING / PLAN DE CABLAGE
PC0381

LOWER CONTROL BOX WITH HOURMETER BOITIER BAS AVEC HORAMETRE

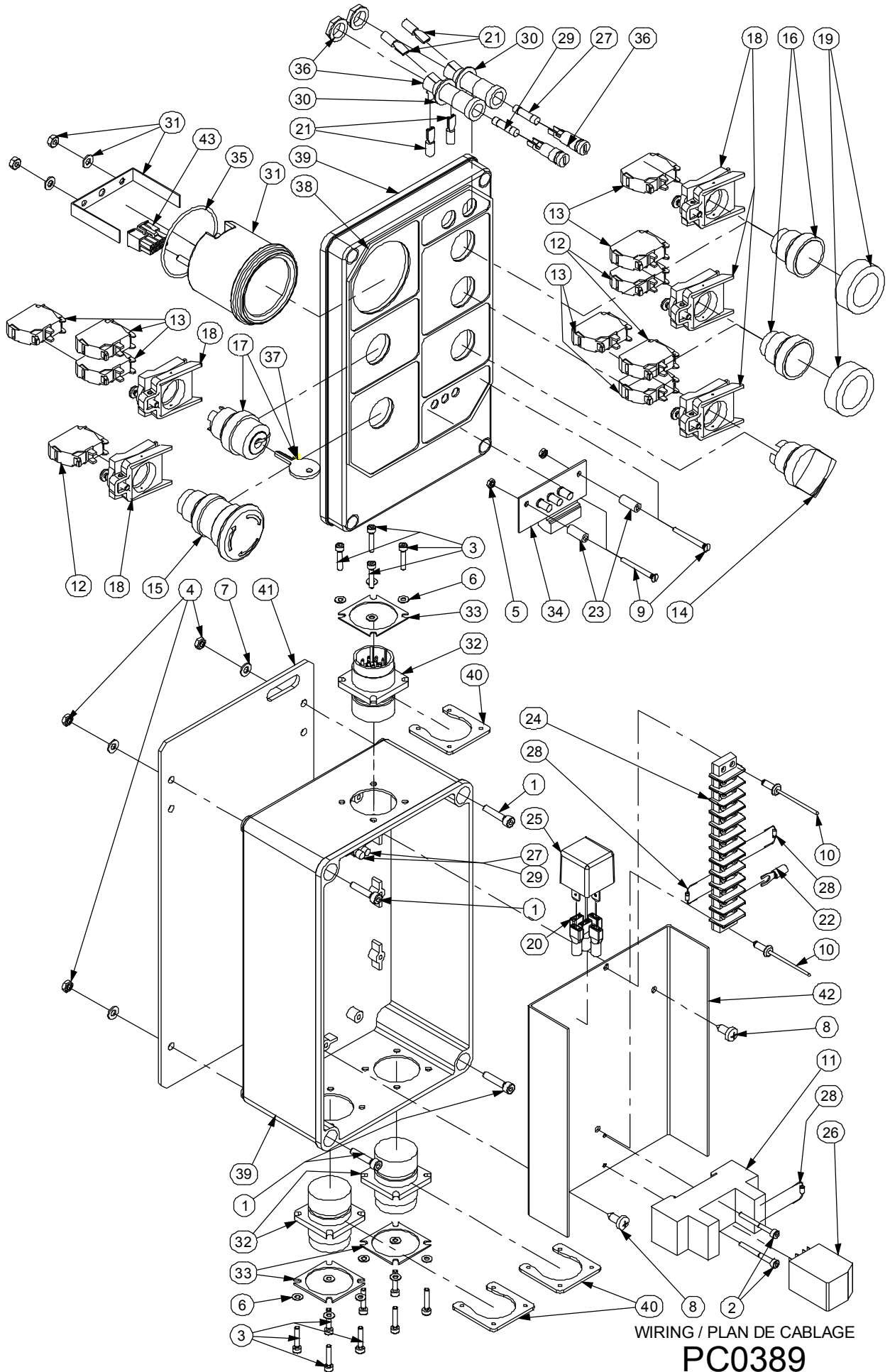

WIRING / PLAN DE CABLAGE
PC0389

ISSUE DATE : 02/05/04

LOWER CONTROL BOX WITH HOURMETER

ISSUE REL :

ASSEMBLY N° :
N° ENSEMBLE : SP0883 REV :

BOITIER BAS AVEC HORAMETRE

1/2

DET REP	PART NUMBER REF.	SEE VIEW VOIR VUE	DESCRIPTION		R E V	QTY QTE
1	000020		M04x20 8.8 SOCKET HEAD MACH SCREW	VIS CHC M04x20 8.8 BI FT		4
2	000052		M03x30 8.8 SOCKET HEAD MACH SCREW	VIS CHC M03x30 8.8 BR FT		2
3	000091		M03x16 8.8 SOCKET HEAD MACH SCREW	VIS CHC M03x16 8.8 BI FT		12
4	110001		M04 GR. 8.8 LOCK NUT	ECROU FREIN M4 8.8 BI		4
5	110024		M03 GR. 8.8 LOCK NUT	ECROU FREIN M03 8.8 BI		2
6	120023		M03 LOCK WASHER	RONDELLE CONTACT M03 BI		12
7	120024		M04 LOCK WASHER	RONDELLE CONTACT M04 BI		4
8	130007		Ø4.8x13 LG SHEET METAL SCREW	VIS AUTOTARAUDEUSE Ø4.8-13 BI		2
9	130052		M03x30 8.8 COUNTERSUNK HEAD M. S.	VIS FHC M03x30 8.8 BI FT		2
10	180002		Ø4x10 POP RIVET	RIVET POP Ø4x10		2
11	240019		4RT RELAY BASE	EMBASE DE RELAIS 4RT		1
12	240057		NC CONTACT BLOCK	CONTACT NF		3
13	240058		NO CONTACT BLOCK	CONTACT NO		7
14	240059		2 POSITIONS SELECTOR	SELECTEUR 2 POSITIONS		1
15	240060		TURN TO RELEASE KNOB	BOUTON D'ARRET D'URGENCE 1/4 TOUR		1
16	240061		PUSH BUTTON	BOUTON POUSSOIR		2
17	240066		3 POSITIONS KEY SELECTOR	SELECTEUR A CLE 3 POSITIONS		1
18	240076		CONTACT BLOCK HOLDER	EMBASE CONTACT		5
19	240082		PUSH BUTTON CAP	CAPUCHON D'ETANCHEITE		2
20	250027		BLUE RECEPTACLE TER. 6.3 - 1.5-2.5mm ²	COSSE FEM. 6.3 BLEUE 6.3 - 1.5-2.5mm ²		5
21	250060		RECEPTACLE TERMINAL 4.8 - 0.25-1 mm ²	COSSE ISOLEE 4.8 mm 0.25-1 mm ²		4
22	250085		M04 FORK TERMINAL 0.5-1mm ²	COSSE FOURCHE M04 - 0.5-1mm ²		21
23	250184		Ø 3 lg 14 PLASTIC SPACER	ENTRETOISE PVC Ø 3 lg 14		2
24	250191		12 PTS TERMINAL BLOCK	BARETTE DE CONNEXION 12 PTS		1
25	260019		1RT 24V RELAY	RELAIS 24 V 1RT		1
26	260042		4RT RELAY	RELAIS 4RT		1
27	260074		5A QUICK ACTING FUSE	FUSIBLE RAPIDE 5A		2
28	260093		1A DIODE	DIODE 1A		3
29	260104		500mA QUICK ACTING FUSE	FUSIBLE RAPIDE 500mA		2
30	260134		TOGGLE SWITCH GASKET	JOINT D'INVERSEUR		2
31	260142		24V HOURMETRE BATTERY INDICATOR	INDICATEUR DE DECHARGE HORAMETRE		1
32	260166		18 POSITIONS CHASSIS PLUG HOUSING	EMBASE CONNECTEUR 18 CONTACTS		3
33	260167		18 POSITIONS CHASSIS PLUG GASCKET	JOINT CONNECTEUR 18 CONTACTS		3
34	260174		CHARGER LEDS DISPLAY	CARTE DE VISUALISATION CHARGEUR		1
35	260209		CHARGE INDICATOR RING	JOINT INDICATEUR DE DECHARGE		1
36	260224		FUSE HOLDER	PORTE FUSIBLE		2
37	910003		KEY N°421	CLE N°421		1

***SPARE PARTS
PIECES DETACHEES***

SECTION 3

**MASTS ON FRAME INSTALL
INSTALLATION MATS SUR CHASSIS**



MASTS ON FRAME INSTALL INSTALLATION MATS SUR CHASSIS

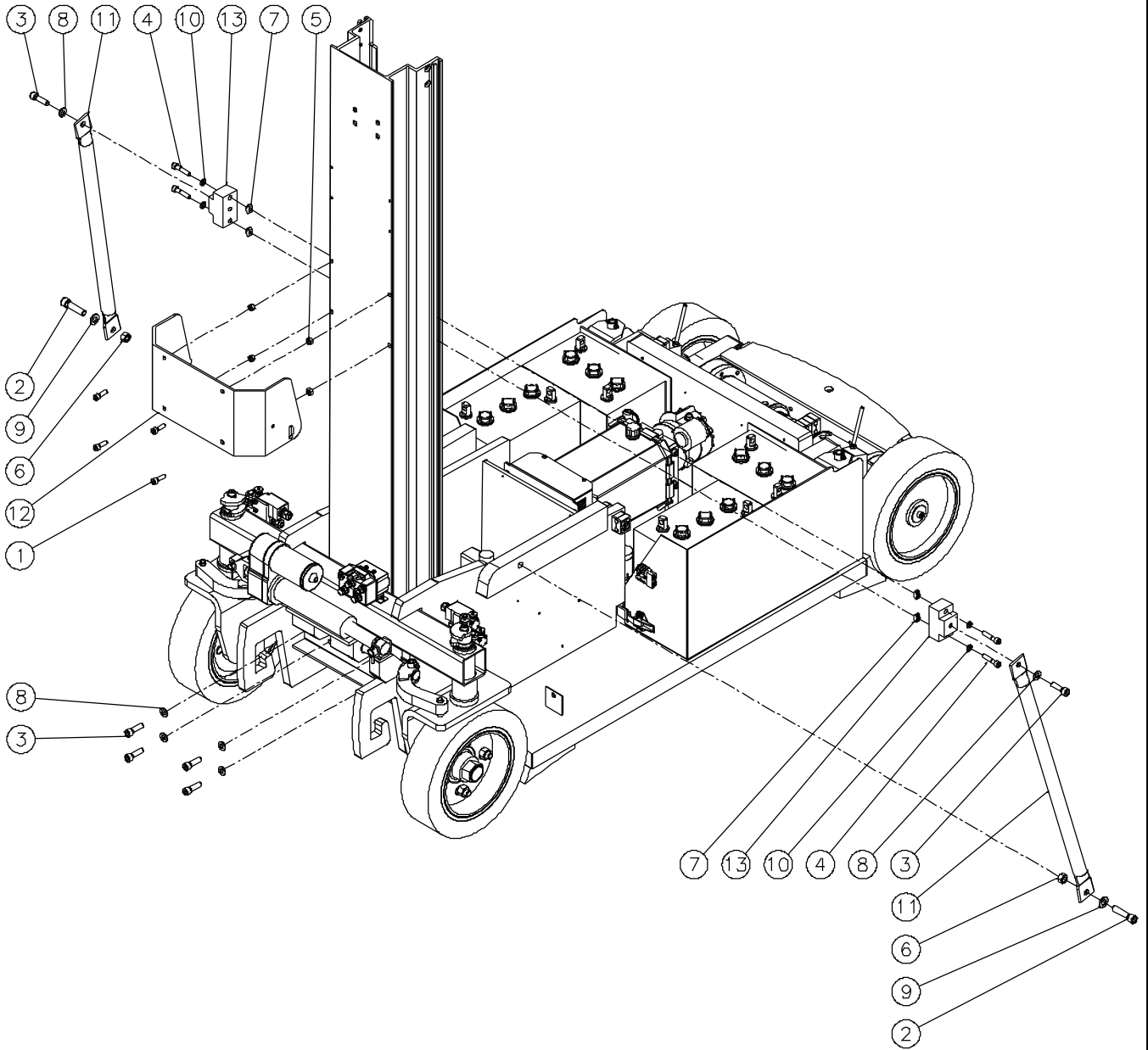

SPARE PARTS
PIECES DETACHEES

SECTION 4

FRAME INSTALL
INSTALLATION CHASSIS



FRAME INSTALL INSTALLATION CHASSIS

- Settings for standard batteries :
 -Toggle the switch 1 to "on"
 -Toggle the switch 2 to "off"
- Settings for gel batteries :
 -Toggle the switch 1 to "off"
 -Toggle the switch 2 to "on"

- Les réglages pour les batteries standard sont :
 -Basculer l'interrupteur 1 sur "on"
 -Basculer l'interrupteur 2 sur "off"
- Les réglages pour les batteries gel sont :
 -Basculer l'interrupteur 1 sur "off"
 -Basculer l'interrupteur 2 sur "on"

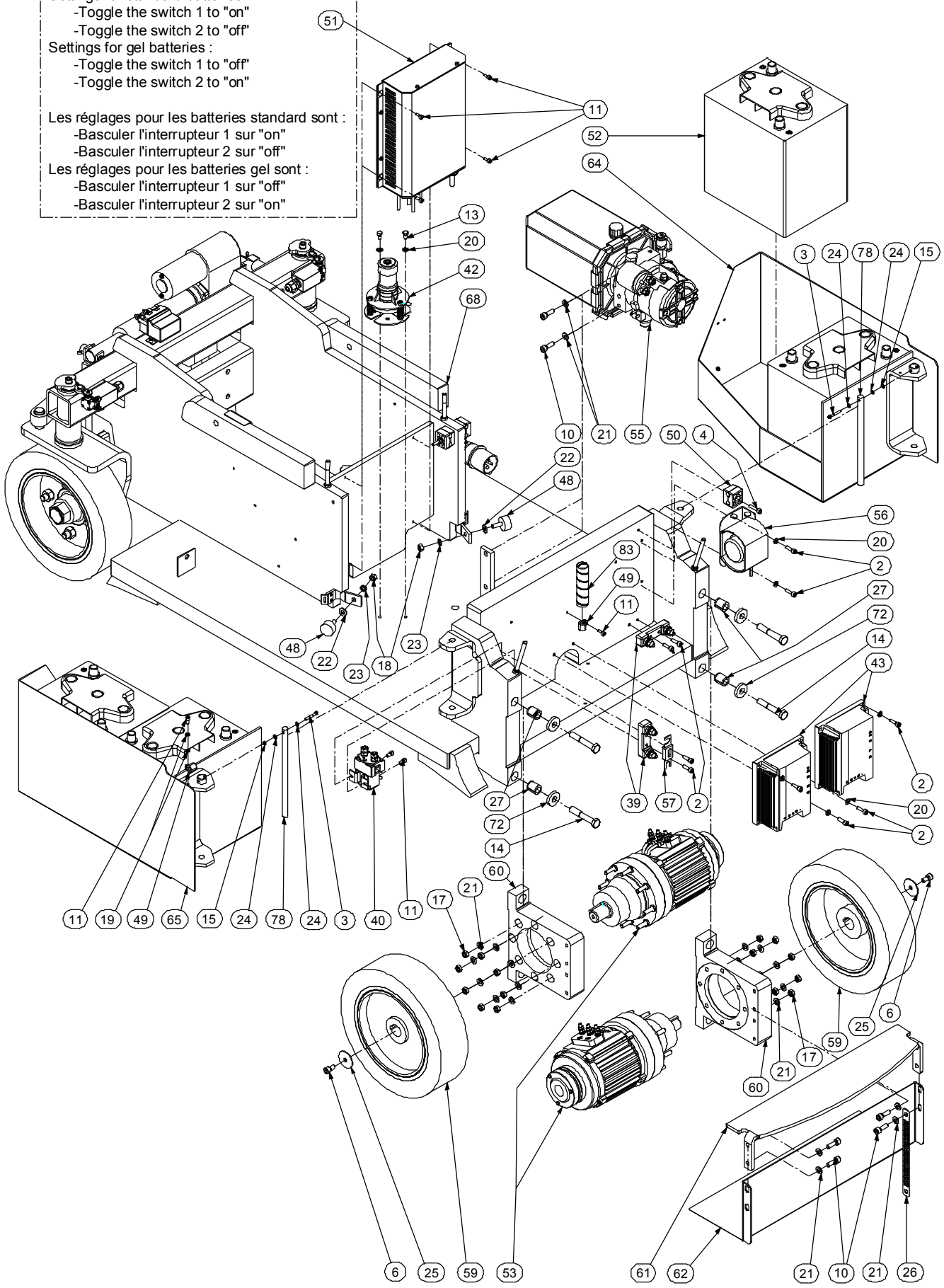

FRAME INSTALL INSTALLATION CHASSIS

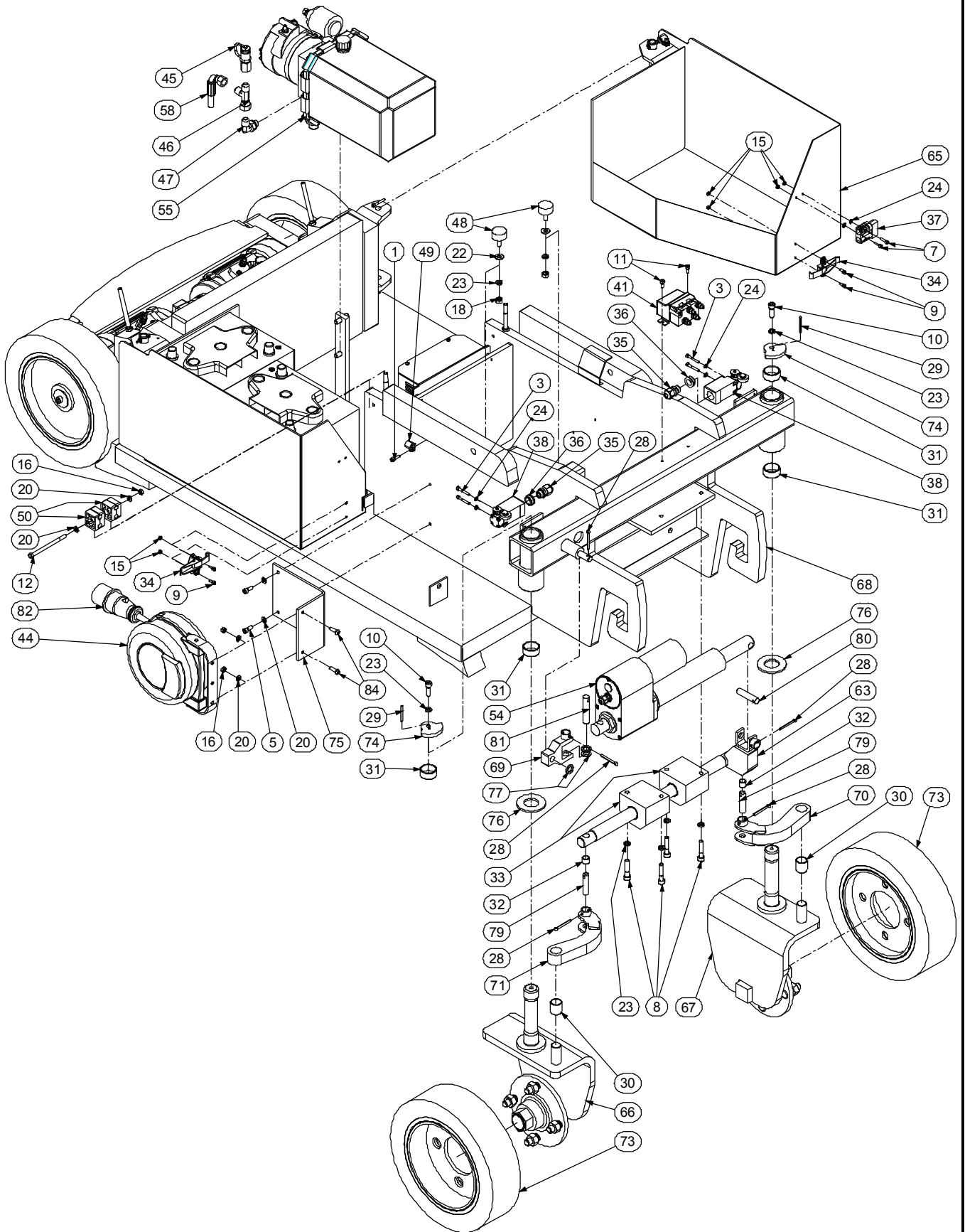

ISSUE DATE : 02/06/04

FRAME INSTALL

ISSUE REL :

ASSEMBLY N° :
N° ENSEMBLE : SP0811 REV : A**INSTALLATION CHASSIS**

1/3

DET REP	PART NUMBER REF.	SEE VIEW VOIR VUE	DESCRIPTION		R E V	QTY QTE
1	000003		M05x16 8.8 SOCKET HEAD MACH SCREW	VIS CHC M05x16 8.8 BI FT		1
2	000005		M06x20 8.8 SOCKET HEAD MACH SCREW	VIS CHC M06x20 8.8 BI FT	A	10
3	000007		M04x30 8.8 SOCKET HEAD CAPSCREW	VIS CHC M04x30 8.8 BI FP		6
4	000008		M06x25 8.8 SOCKET HEAD MACH SCREW	VIS CHC M06x25 8.8 BI FT		1
5	000015		M06x16 8.8 SOCKET HEAD MACH SCREW	VIS CHC M06x16 8.8 BI FT		2
6	000018		M08x16 8.8 SOCKET HEAD MACH SCREW	VIS CHC M08x16 8.8 BI FT		2
7	000020		M04x20 8.8 SOCKET HEAD MACH SCREW	VIS CHC M04x20 8.8 BI FT		2
8	000043		M08x40 8.8 SOCKET HEAD MACH SCREW	VIS CHC M08x40 8.8 BI FT		4
9	000050		M04x10 8.8 SOCKET HEAD MACH SCREW	VIS CHC M04x10 8.8 BI FT		4
10	000053		M08x25 8.8 SOCKET HEAD MACH SCREW	VIS CHC M08x25 8.8 BI FT		8
11	000067		M05x12 8.8 SOCKET HEAD MACH SCREW	VIS CHC M05x12 8.8 BI FT		10
12	100014		M06x80 8.8 HEX HEAD CAPSCREW	VIS H M06x80 8.8 BI FP		1
13	100027		M06x12 8.8 HEX HEAD MACHINE SCREW	VIS H M06x12 8.8 BI FT		2
14	100035		M12x70 8.8 HEX HEAD CAPSCREW	VIS H M12x70 BI FP		4
15	110001		M04 GR. 8.8 LOCK NUT	ECROU FREIN M4 8.8 BI		8
16	110003		M06 GR. 8.8 LOCK NUT	ECROU FREIN M6 8.8 BI		3
17	110004		M08 GR. 8.8 LOCK NUT	ECROU FREIN M8 8.8 BI		16
18	110016		M08 GR. 8.8 HEX NUT	ECROU H M08 8.8 BI		4
19	120002		M05 WASHER	RONDELLE M05 BI		2
20	120009		dD 06x14 LOCK WASHER	RONDELLE CONTACT dD 06x14 BI		14
21	120010		dD 08x18 LOCK WASHER	RONDELLE CONTACT dD 08x18 BI		22
22	120014		M08 WASHER	RONDELLE M08 BI		4
23	120021		HELICAL SPRING LOCK WASHER Ø8	RONDELLE GROWER Ø8 BI		10
24	120024		M04 LOCK WASHER	RONDELLE CONTACT M04 BI		10
25	120026		dD 08x40 WASHER	RONDELLE dD 08x40 BI		2
26	130022		STATIC STRAP	TRESSE DE MASSE		1
27	140018		SAFETY PIN	GOUPILLE ELASTIQUE		4
28	140019		Ø4x40 COTTER PIN	GOUPILLE FENDUE Ø4x40		5
29	140022		Ø4x40x0.8 LOCK PIN	GOUPILLE ELASTIQUE Ø4x40x0.8		2
30	150022		BUSHING Ø20 H25 DX	BAGUE Ø20 H25 DX		2
31	150025		BUSHING Ø30 H15 DU	BAGUE Ø30 H15 DU		4
32	150029		Ø12 H12 BUSHING	BAGUE Ø12 H12		2
33	150044		PILLOW BLOCK	PALIER A SEMELLE		2
34	190043		IRON LACK	GRENOUILLE A BRAS RESSORT		2
35	210017		GLAND N°9	PRESSE ETOUPE N°9		2
36	250015		REDUCTION 13/9	REDUCTION 13/9		2
37	250038		QUICK CONNECTOR	PRISE RAPIDE		1

ISSUE DATE : 02/06/04

FRAME INSTALL

ISSUE REL :

ASSEMBLY N° :
N° ENSEMBLE : SP0811 REV : A**INSTALLATION CHASSIS**

2/3

DET REP	PART NUMBER REF.	SEE VIEW VOIR VUE	DESCRIPTION		R E V	QTY QTE
38	260030		2NC SWITCH	CAPTEUR 2NF		2
39	260077		POWER FUSE HOLDER	PORTE FUSIBLE DE PUISSANCE	A	2
40	260208		RELAY	RELAIS		1
41	260269		INVERTER RELAY	RELAIS INVERSEUR		1
42	260270		2° TILT SENSOR	DETECTEUR DE DEVERS 2°		1
43	260286		FREQUENCY CONVERTER	CONVERTISSEUR DE FREQUENCE		2
44	260287		CABLE REAL	ENROULEUR		1
45	300004		PRESSURE TEST PLUG JIC9/16 SMK	PRISE DE PRESSION JIC 9/16 SMK		1
46	300037		RUN TEE JIC 9/16 SWIVEL NUT	TE MALE JIC9/16-FEMELLE JIC9/16 TOUR.		1
47	300075		90° ELBOW MALE M14x150-MALE JIC 9/16	COUDE 90° MALE M14x150-MALE JIC 9/16		1
48	400015		ELASTIC STOP	BUTEE ELASTIQUE		4
49	400034		COLLAR	COLLIER		3
50	400037		PAIR 1/2 SHELL DOUBLE	PAIRE DE DEMI COQUILLE		3
51	510047		STANDARD CHARGER	CHARGEUR STANDARD		1
52	951011		6V 180Ah DRY BATTERIE	BATTERIE SECHE 6V 180Ah		4
52	510062		GEL BATTERY 6V 180Ah	BATTERIE GEL 6V 180Ah		4
53	510073		INDUCTION GEAR MOTOR	MOTOREDUCTEUR + FREIN ASYNCHRONE		2
54	510074		STEERING ELECTRICAL CYLINDER	VERIN ELECTRIQUE DE DIRECTION		1
55	520099	520099	COMPLETE POWER UNIT 1.25cc	CENTRALE COMPLETE 1.25cm³	A	1
56	7025000801		MOTION ALARM (=260275)	ALARME DE MOUVEMENT (=260275)		1
57	950110		63A FUSE	FUSIBLE 63A		1
58	DF0656		HOSE (flexible) 1/4" 125cm JIC Fem 9/16 90°-JIC Fem 9/16 90°-90°			1
59	DL0441		NON MARKING DRIVING WHEEL	ROUE MOTRICE NON MARQUANTE		2
60	DL0443		MOTOR FLANGE	BRIDE MOTEUR		2
61	DL0445		STEP	MARCHE PIED		1
62	DL0456		MOTORS GUARD	TOLE DE PROTECTION MOTEURS		1
63	DL0555		TRANSMISSION LUG	PATTE DE TRANSMISSION		1
64	DL0557		RIGHT BATTERY HOUSING	CAISSON DE BATTERIE DROIT		1
65	DL0558		LEFT BATTERY HOUSING	CAISSON DE BATTERIE GAUCHE		1
66	DL0576		RIGHT STEERING BRACKET	EQUERRE DE DIRECTION DROITE		1
67	DL0577		LEFT STEERING BRACKET	EQUERRE DE DIRECTION GAUCHE		1
68	DL0722		FRAME WELDMENT	CHASSIS MECANOSOUE		1
69	SD0530		STEERING CYLINDER YOKE	CHAPE VERIN DE DIRECTION		1
70	SD0549		LEFT STEERING ARM	BIELETTE DE DIRECTION GAUCHE		1
71	SD0550		RIGHT STEERING ARM	BIELETTE DE DIRECTION DROITE		1
72	ST1648		MOTOR WASHER	RONDELLE MOTEUR		4
73	ST2056		NON MARKING STEERING WHEEL	ROUE DIRECTRICE NON MARQUANTE		2

ISSUE DATE : 21/05/02

CHARGER CONNECTOR

ISSUE REL :

ASSEMBLY N° : RM0059 REV :
 N° ENSEMBLE :

PRISE CHARGEUR

1/1

DET REP	PART NUMBER REF.	SEE VIEW VOIR VUE	DESCRIPTION		R E V	QTY QTE
1	7364002824		US 125 VAC MALE CONNECTOR (=260276)	PRISE US 125VAC (=260276)		1
2	260213		Yellow CONNECTOR 110VAC/16A CEI, IP44	PRISE MALE Jaune 110VAC/16A CEI, IP44		1
3	250117		UK 220 VAC MALE CONNECTOR	PRISE MALE 220VAC ROYAUME UNI		1
4	260231		BLUE CONNECTOR 220VAC/16A CEI, IP44	PRISE MALE BLEUE 220VAC/16A CEI, IP44		1
5	260214		FRENCH AND GERMAN 220V CONNECTOR	PRISE 220V FRANCAISE ET ALLEMANDE		1
6	260263		BLUE CONNECTOR 220VAC/32A CEI, IP44	PRISE MALE BLEUE 220VAC/32A CEI, IP44		1
7	260266		Yellow CONNECTOR 110VAC/32A CEI, IP44	PRISE MALE Jaune 110VAC/32A CEI, IP44		1

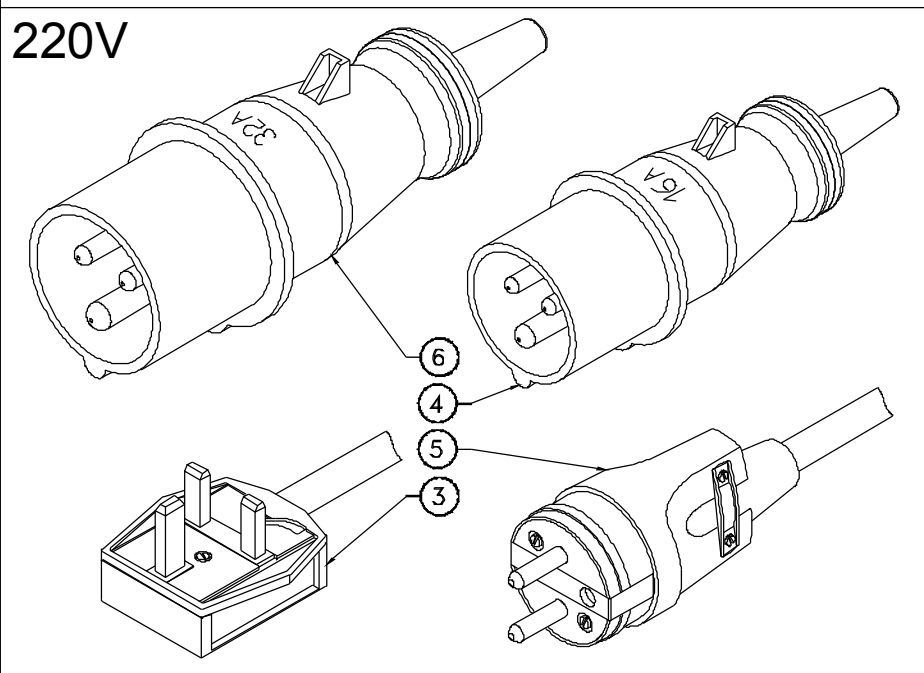
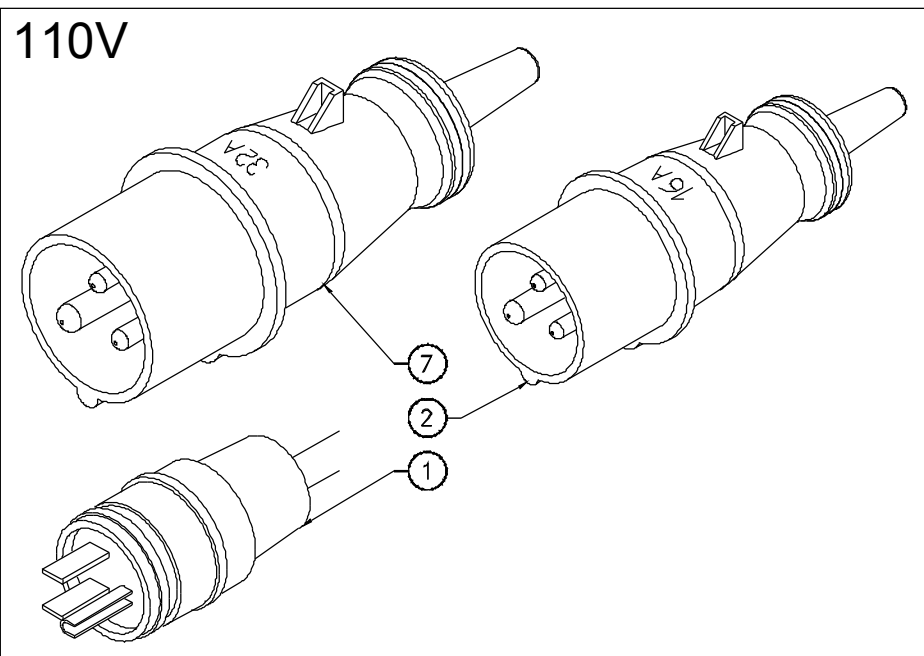

COMPLETE POWER UNIT CENTRALE COMPLETE

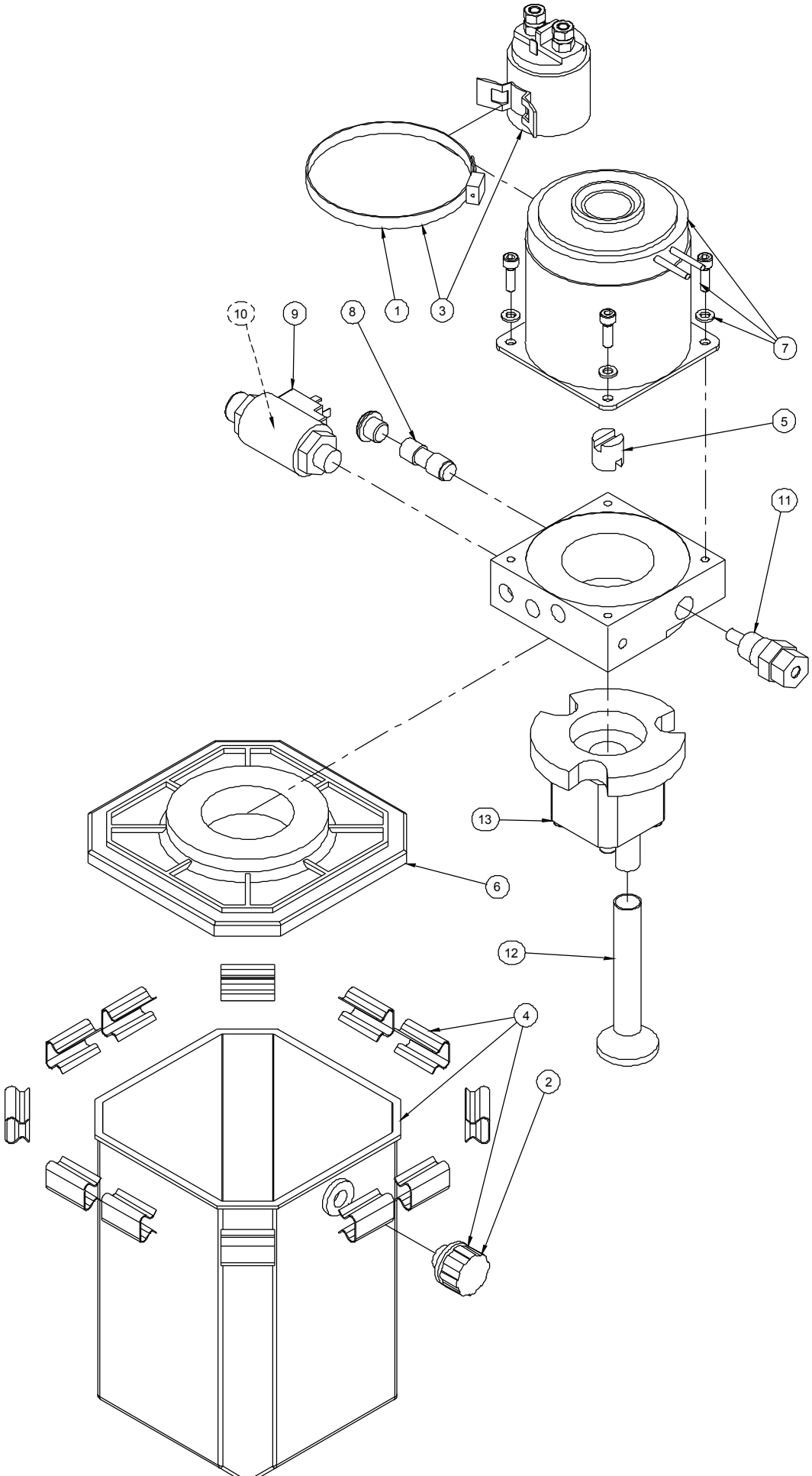

SPARE PARTS
PIECES DETACHEES

SECTION 5

MASTS INSTALL
INSTALLATION MATS



MASTS INSTALL INSTALLATION MATS

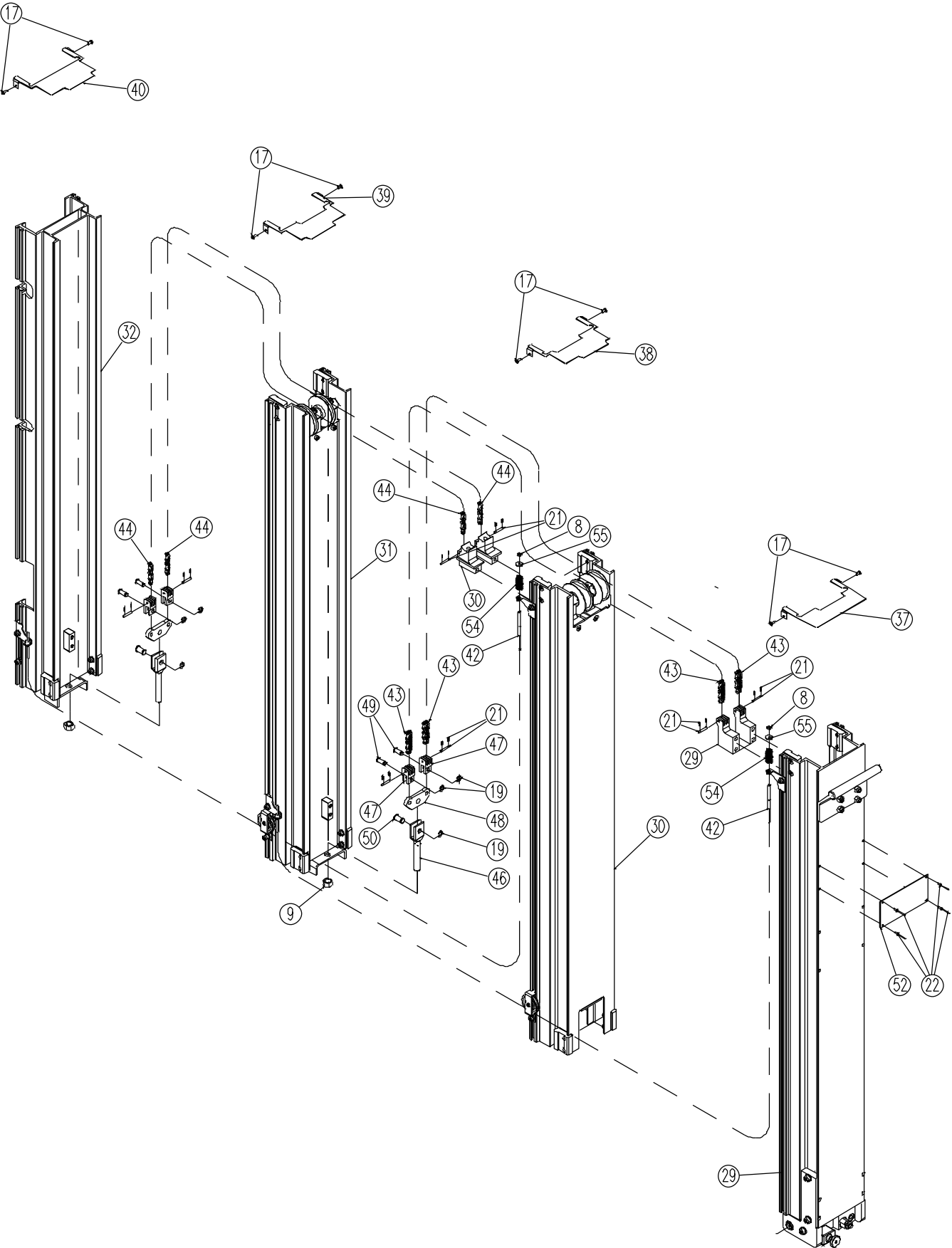

MASTS INSTALL INSTALLATION MATS

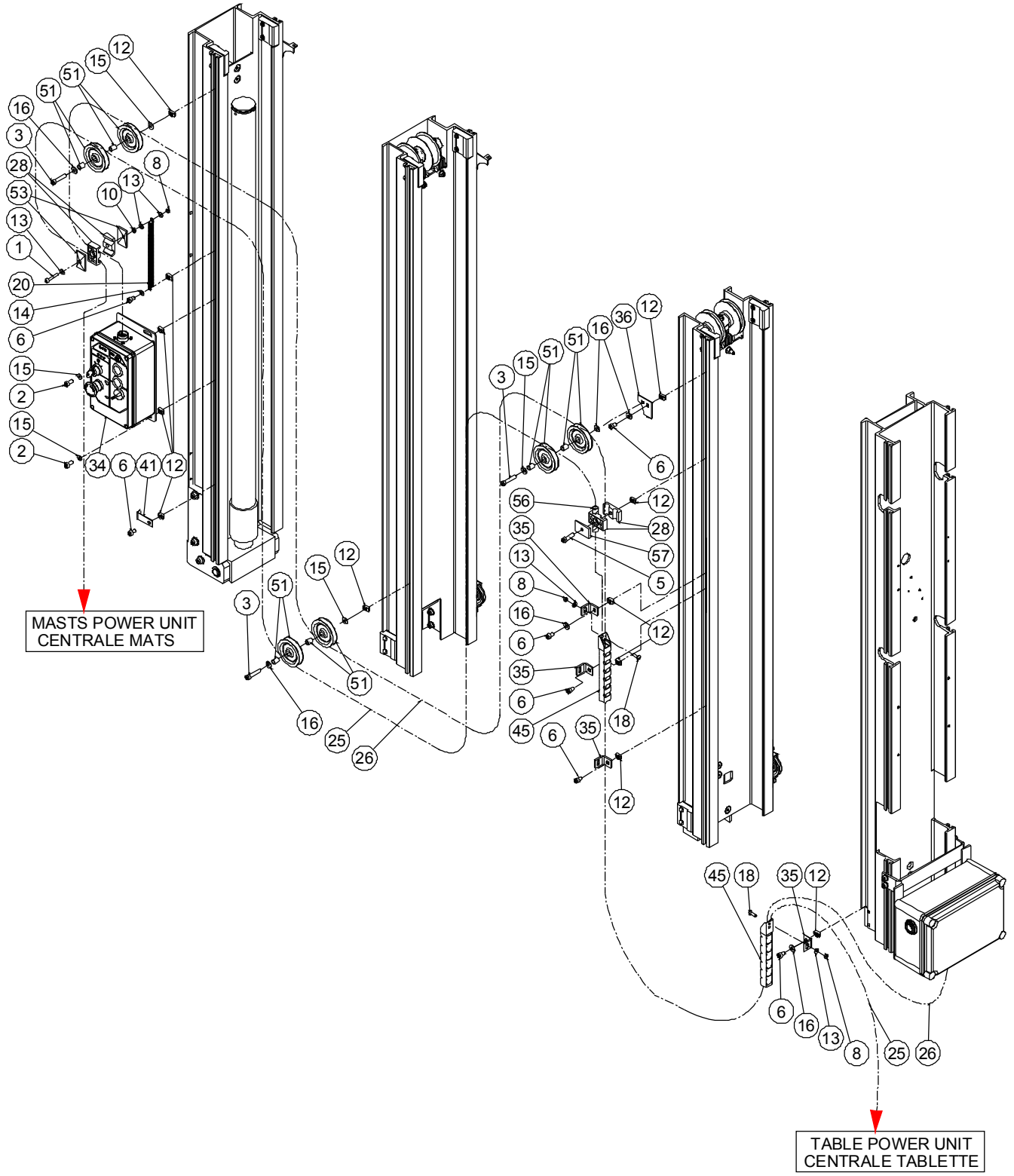

ISSUE DATE : 02/05/04

MASTS INSTALL

ISSUE REL :

INSTALLATION MATS

ASSY NO : SP0806 REV : A

1/2

DET NO.	PART NUMBER	SEE VIEW	DESCRIPTION		REV	QTY REQ.
1	000076		M06x60 8.8 SOCKET HEAD CAPSCREW	VIS CHC M06x60 8.8 BI FP		1
2	000042		M08x12 8.8 SOCKET HEAD MACH SCREW	VIS CHC M08x12 8.8 BI FT		2
3	000078		M08x55 8.8 SOCKET HEAD CAPSCREW	VIS CHC M08x55 8.8 BI FP		3
4			NOT REQUIRED	NON REQUIS		
5	000043		M08x40 8.8 SOCKET HEAD MACH SCREW	VIS CHC M08x40 8.8 BI FT		1
6	000059		M08x12 8.8 S SOCK HEAD MACH SCREW	VIS CHC M08x12 8.8 BI FT TETE BASSE		7
7			NOT REQUIRED	NON REQUIS		
8	110003		M06 GR. 8.8 LOCK NUT	ECROU FREIN M6 8.8 BI		5
9	110011		M16 GR. 10.9 LOCK NUT	ECROU FREIN M16 10.9 BI		2
10	110015		M06 GR. 8.8 HEX NUT	ECROU H M06 8.8 BI		1
11			NOT REQUIRED	NON REQUIS		
12	110030		M08 RECTANGULAR BASE NUT	ECROU A EMBASE RECTANGULAIRE M08		12
13	120009		dD 06x14 LOCK WASHER	RONDELLE CONTACT dD 06x14 BI		5
14	120010		dD 08x18 LOCK WASHER	RONDELLE CONTACT dD 08x18 BI		1
15	120014		M08 WASHER	RONDELLE M08 BI		5
16	120021		HELICAL SPRING LOCK WASHER Ø8	RONDELLE GROWER Ø8 BI		6
17	130007		Ø4.8x13 LG SHEET METAL SCREW	VIS AUTOTARAUDEUSE Ø4.8-13 BI		8
18	130021		M06x20 8.8 ROUND HEAD MACH SCREW	VIS BOMBEE ULF M06x20 8.8 BI FT		2
19	130028		RETAINING RING Ø9	CIRCLIPS EXTERIEUR Ø9		6
20	160024		SPRING	RESSORT		1
21	170004		CLEVIS PIN	AXE DE CHAPE		8
22	180002		Ø4x10 POP RIVET	RIVET POP Ø4x10		4
23			NOT REQUIRED	NON REQUIS		
24			NOT REQUIRED	NON REQUIS		
25	270060		CABLE 3G1.5mm ² Color leads (qty in meters)	CABLE 3G1.5mm ² coloré (qté en mètre)		6.1
26	270057		CABLE 18x0.75mm ² (qty indicated in meter)	CABLE 18x0.75mm ² (qté indiquée en mètre)		5.3
27			NOT REQUIRED	NON REQUIS		
28	400037		PAIR 1/2 SHELL DOUBLE	PAIRE DE DEMI COQUILLE		2
29		SP0813	MAST 1 ASSEMBLY	ASSEMBLAGE MAT 1		1
30		SP0386	MAST 2 ASSEMBLY	ASSEMBLAGE MAT 2		1
31		SP0387	MAST (3/TJ6/Tduo or 5/TJ8) ASSEMBLY	ASSEMBLAGE MAT (3/TJ6/Tduo ou 5/TJ8)		1
32		SP0807	MAST 4 ASSEMBLY	ASSEMBLAGE MAT 4		1
33			NOT REQUIRED	NON REQUIS		
34		SP0805	LOWER CONTROL BOX ASSEMBLY	ASSEMBLAGE BOITIER BAS		1
34		SP0883	LOWER CONTROL BOX WITH HOURMETE	BOITIER BAS AVEC HORAMETRE		1
35	ST1110		PLATFORM T-BRACKET	EQUERRE PANIER		4
36	ST1120		PULLEY BRACKET	SUPPORT POULIE		1

ISSUE DATE : 02/05/04

MASTS INSTALL

ISSUE REL :

INSTALLATION MATS

ASSY NO : SP0806 REV : A

2/2

DET NO.	PART NUMBER	SEE VIEW	DESCRIPTION		REV	QTY REQ.
37	ST1146		MAST TOP COVER 1	CAPOT MAT 1		1
38	ST1147		MAST TOP COVER 2 & 4	CAPOT MAT 2 & 4		1
39	ST1148		MAST TOP COVER 3 & 5	CAPOT MAT 3 & 5		1
40	ST1149		MAST TOP COVER 6	CAPOT MAT 6		1
41	ST1193		WIRE FIXATION	FIXATION CABLE		1
42	ST1627		MAST BACKUP CABLE	CABLE DE RAPPEL DE MATS		2
43	ST1630		LL 10-44 CHAIN	CHAINE LL10-44		2
44	ST1632		LL 10-22 CHAIN	CHAINE LL10-22		2
45	ST1634		POWER BRIDGE	CHEMIN DE CABLE		1
46	US0281		CHAIN ANCHOR	CHAPE DE REGLAGE		2
47	US0282		YOKE	CHAPE DE CHAINE		4
48	US0283		SPREADER	PALONNIER DE REGLAGE		2
49	US0284		CHAIN ANCHOR PIN	AXE DE CHAPE DE CHAINE		4
50	US0285		SPREADER PIN	AXE PALONNIER		2
51	US0360		PULLEY	POULIE		6
52		SECTION 7	MANUFACTURER'S NAME PLATE	PLAQUE CONSTRUCTEUR		1
53	400012		PAIR 1/2 SHELL PLATE	BRIDE PAIRE DEMI COQUILLE		2
54	160022		SPRING	RESSORT		2
55	US0346		FLANGE BUSHING	RONDELLE EPAULEE		2
56	400080		SPIRAL HOUSING PLIOSPIRE D12	GAINES SPIRALE PLIOSPIRE D12		0.02
57	ST2529		DOUBLE CLAMP PLATE	PLAQUE COLLIER DOUBLE		1

MAST 1 ASSEMBLY ASSEMBLAGE MAT 1

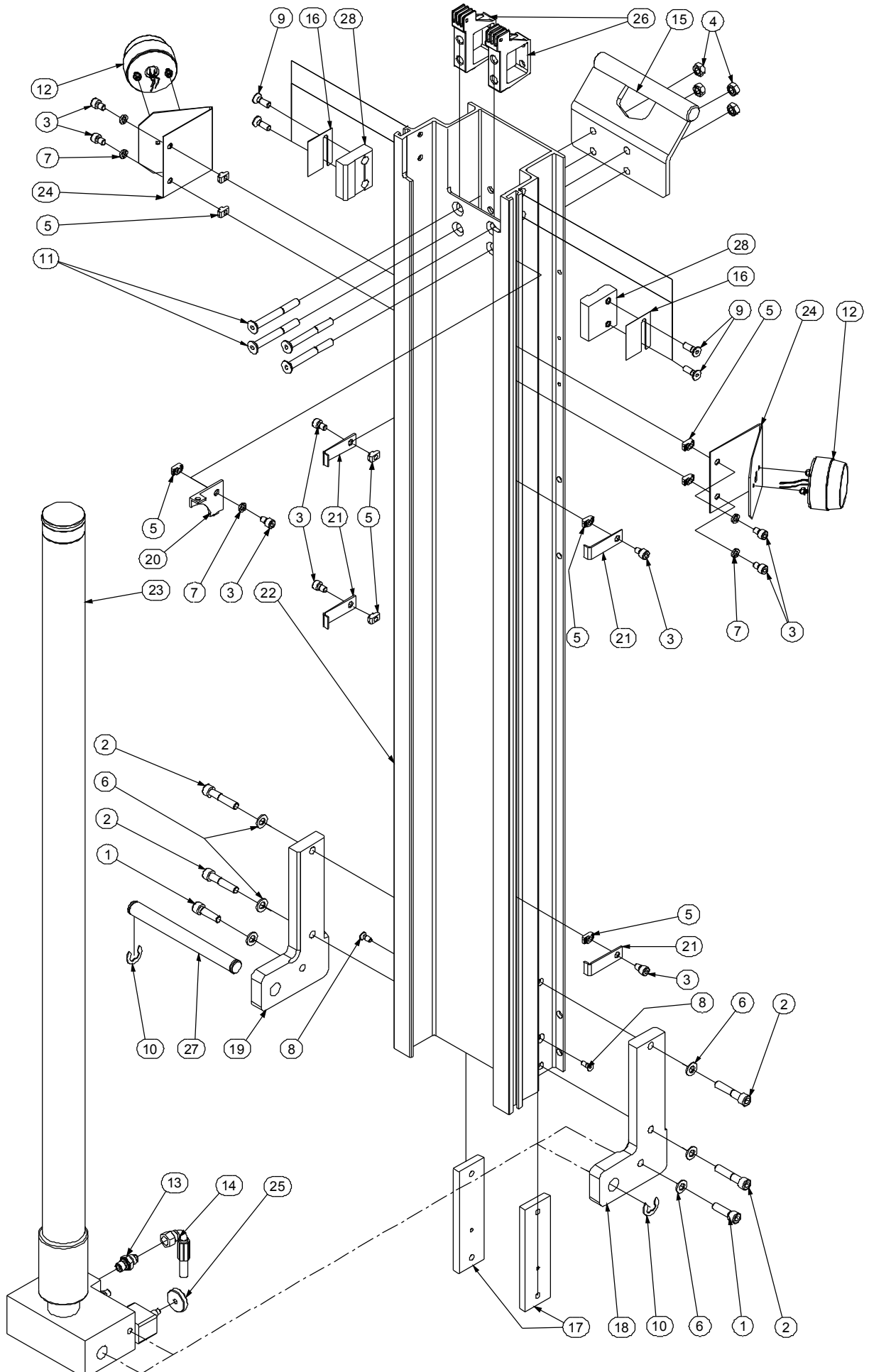

ISSUE DATE : 29/09/03

MAST 1 ASSEMBLY

ISSUE REL :

ASSEMBLAGE MAT 1

ASSEMBLY N° : SP0813 REV :
N° ENSEMBLE :

1/1

DET REP	PART NUMBER REF.	SEE VIEW VOIR VUE	DESCRIPTION		R E V	QTY QTE
1	000019		M10x35 8.8 SOCKET HEAD MACH SCREW	VIS CHC M10x35 8.8 BI FT		2
2	000035		M10x50 12.9 SOCKET HEAD CAPSCREW	VIS CHC M10x50 12.9 BR FT		4
3	000059		M08x12 8.8 S SOCK HEAD MACH SCREW	VIS CHC M08x12 8.8 BI FT TETE BASSE		9
4	110005		M10 GR. 8.8 LOCK NUT	ECROU FREIN M10 8.8 BI		4
5	110030		M08 RECTANGULAR BASE NUT	ECROU A EMBASE RECTANGULAIRE M08		9
6	120011		dD 10x22 LOCK WASHER	RONDELLE CONTACT dD 10x22 BI		6
7	120021		HELICAL SPRING LOCK WASHER Ø8	RONDELLE GROWER Ø8 BI		5
8	130003		M06x16 10.9 COUNTERSUNK HEAD M. S.	VIS FHC M06x16 10.9 BI FT		2
9	130025		M08x25 10.9 COUNTERSUNK HEAD M. S.	VIS FHC M08x25 10.9 BI FT		4
10	130029		RETAINING RING Ø15	CIRCLIPS EXTERIEUR Ø15		2
11	130033		M10x90 10.9 COUNTERSUNK HEAD CAPS	VIS FHC M10x90 10.9 BI FP		4
12	260229		FLASHING LIGHT	FEU A ECLAT		2
13	300025		FITTING MALE BSPP1/4-MALE JIC9/16	RACCORD MALE BSPP1/4-MALE JIC9/16		1
14	DF0574		HOSE (flexible) 1/4 110cm JIC9/16 90° JIC9	FLEXIBLE 1/4 110cm JIC9/16 90° JIC9/16 90°		1
15	DL0440		LIFTING BRACKET	ANNEAU D'ELINGUAGE		1
16	ST1109		SHIM (4 sizes : see Service Manual)	CALE (4 épaisseurs: voir Manuel de Service)		2
17	ST1113		BASE PLATE CYLINDER	BRIDE DE VERIN		2
18	ST1114		LEFT CYLINDER BRACKET	PATTE GAUCHE DE VERIN		1
19	ST1115		RIGHT CYLINDER BRACKET	PATTE DROITE DE VERIN		1
20	ST1119		STEEL WIRE BRACKET	EQUERRE CABLE		1
21	ST1193		WIRE FIXATION	FIXATION CABLE		4
22	ST1625		MAST 1	MAT 1		1
23	ST1628	ST1628	MAST CYLINDER	VERIN DE MAT		1
24	ST2147		FLASHING LIGHT BRACKET	SUPPORT LAMPE A ECLAT		2
25	US0277		CYLINDER EMERGENCY BUTTON	BOUTON D'URGENCE VERIN		1
26	US0278		CHAIN ANCHOR	CHAPE DE CHAINE		2
27	US0289		MAST CYLINDER PIN	AXE VERIN		1
28	US0321		SLIDE BLOCK (4 sizes: see Service Manual)	PATIN (4 épaisseurs: voir Manuel de Service)		2

MAST CYLINDER VERIN DE MAT

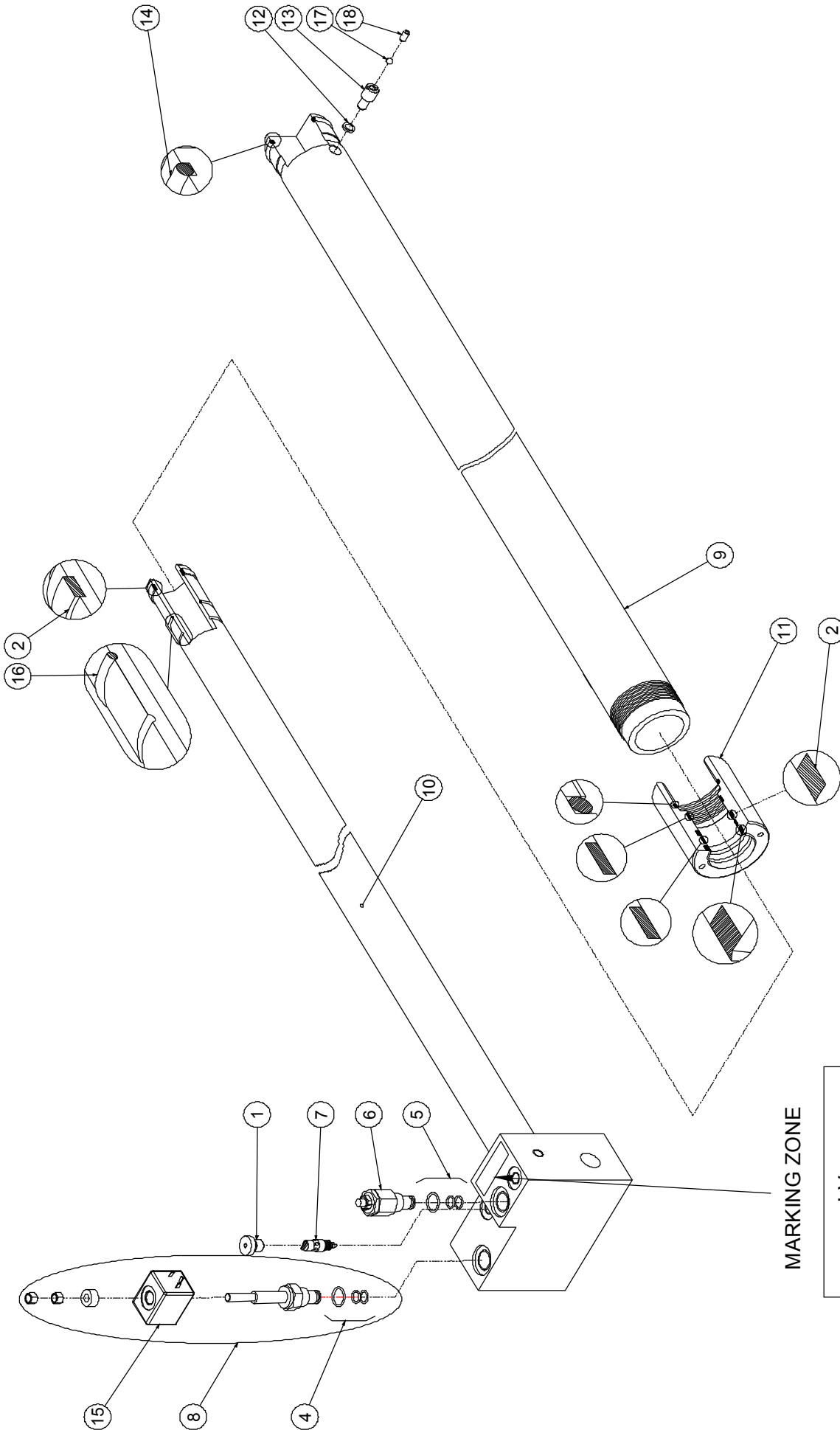

MARKING ZONE

LV
WEEK/SHL/YEAR
STxxxx
900017

MAST 2 ASSEMBLY ASSEMBLAGE MAT 2

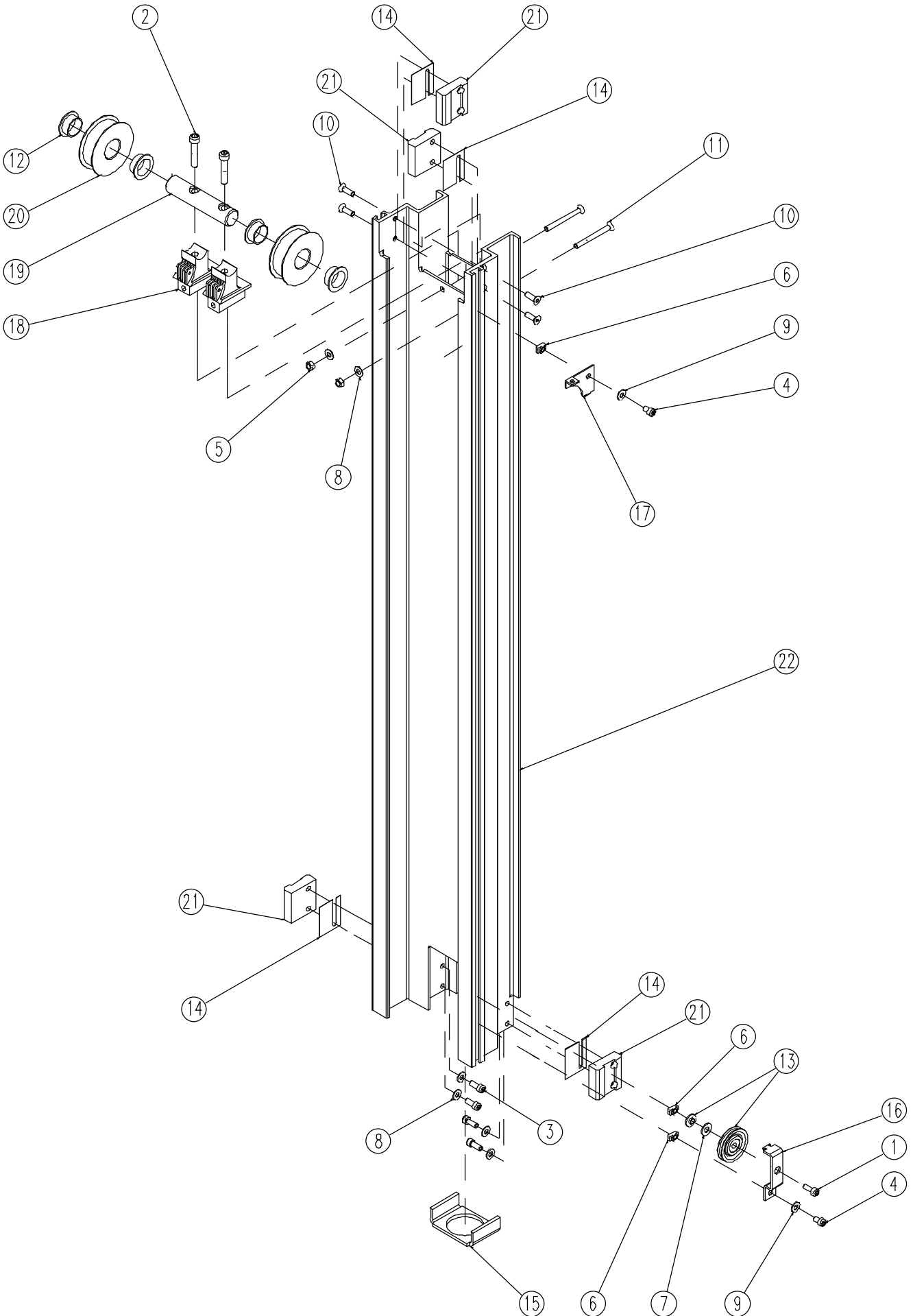

MAST 3 ASSEMBLY ASSEMBLAGE MAT 3

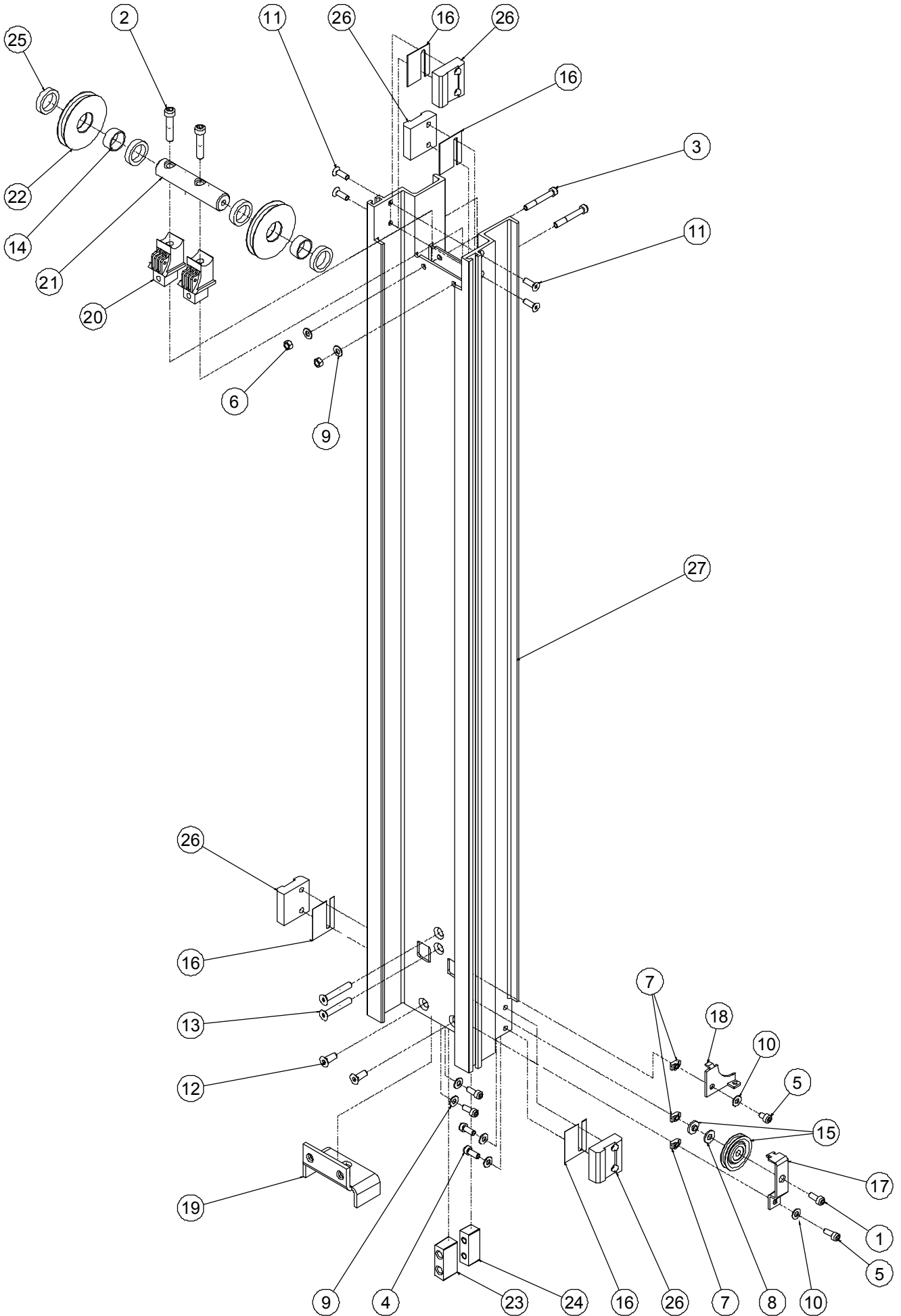

ISSUE DATE : 17/03/03

MAST (3/TJ6/Tduo or 5/TJ8) ASSEMBLY

ISSUE REL :

ASSY NO : SP0387 REV : A

ASSEMBLAGE MAT (3/TJ6/Tduo ou 5/TJ8)

1/1

DET NO.	PART NUMBER	SEE VIEW	DESCRIPTION		REV	QTY REQ.
1	000006		M08x20 8.8 SOCKET HEAD MACH SCREW	VIS CHC M08x20 8.8 BI FT		1
2	000035		M10x50 12.9 SOCKET HEAD CAPSCREW	VIS CHC M10x50 12.9 BR FT		2
3	000057		M08x60 8.8 S SOCKET HEAD CAPSCREW	VIS CHC M08x60 8.8 BI FT TETE BASSE		2
4	000058		M08x20 8.8 S SOCK. HEAD MACH SCREW	VIS CHC M08x20 8.8 BI FT TETE BASSE		4
5	000059		M08x12 8.8 S SOCK HEAD MACH SCREW	VIS CHC M08x12 8.8 BI FT TETE BASSE		2
6	110004		M08 GR. 8.8 LOCK NUT	ECROU FREIN M8 8.8 BI		2
7	110030		M08 RECTANGULAR BASE NUT	ECROU A EMBASE RECTANGULAIRE M08		3
8	120011		dD 10x22 LOCK WASHER	RONDELLE CONTACT dD 10x22 BI		1
9	120014		M08 WASHER	RONDELLE M08 BI		6
10	120021		HELICAL SPRING LOCK WASHER Ø8	RONDELLE GROWER Ø8 BI		2
11	130025		M08x25 10.9 COUNTERSUNK HEAD M. S.	VIS FHC M08x25 10.9 BI FT		4
12	130030		M010x25 10.9 COUNTERSUNK HEAD M. S.	VIS FHC M10x25 10.9 BI FT		2
13	130032		M010x60 10.9 COUNTERSUNK HEAD M. S.	VIS FHC M10x60 10.9 BI FT		2
14	150025		BUSHING Ø30 H15 DU	BAGUE Ø30 H15 DU		2
15	150028		BACKUP PULLEY	POULIE DE RAPPEL		1
16	ST1109		SHIM (4 sizes : see Service Manual)	CALE (4 épaisseurs: voir Manuel de Service)		4
17	ST1118		BACKUP PULLEY SUPPORT	SUPPORT POULIE DE RAPPEL		1
18	ST1119		STEEL WIRE BRACKET	EQUERRE CABLE		1
19	ST1125		SPREADER BRACKET	EQUERRE PALONNIER		1
20	US0280		PULLEY SUPPORT B	SUPPORT POULIE B		2
21	US0286		PULLEY PIN	AXE DE POULIE		1
22	US0474		PULLEY Ø83x10	POULIE Ø83x10	A	2
23	US0296		SAFETY SPACER	ENTRETOISE DE SECURITE		1
24	US0297		SAFETY BLOCK	SECURITE PALONNIER		1
25	US0298		PULLEY SPACER	ENTRETOISE POULIES		4
26	US0321		SLIDE BLOCK (4 sizes: see Service Manual)	PATIN (4 épaisseurs: voir Manuel de Service)		4
27	ST1631		MAST 3	MAT 3		1

MAST 4 ASSEMBLY ASSEMBLAGE MAT 4

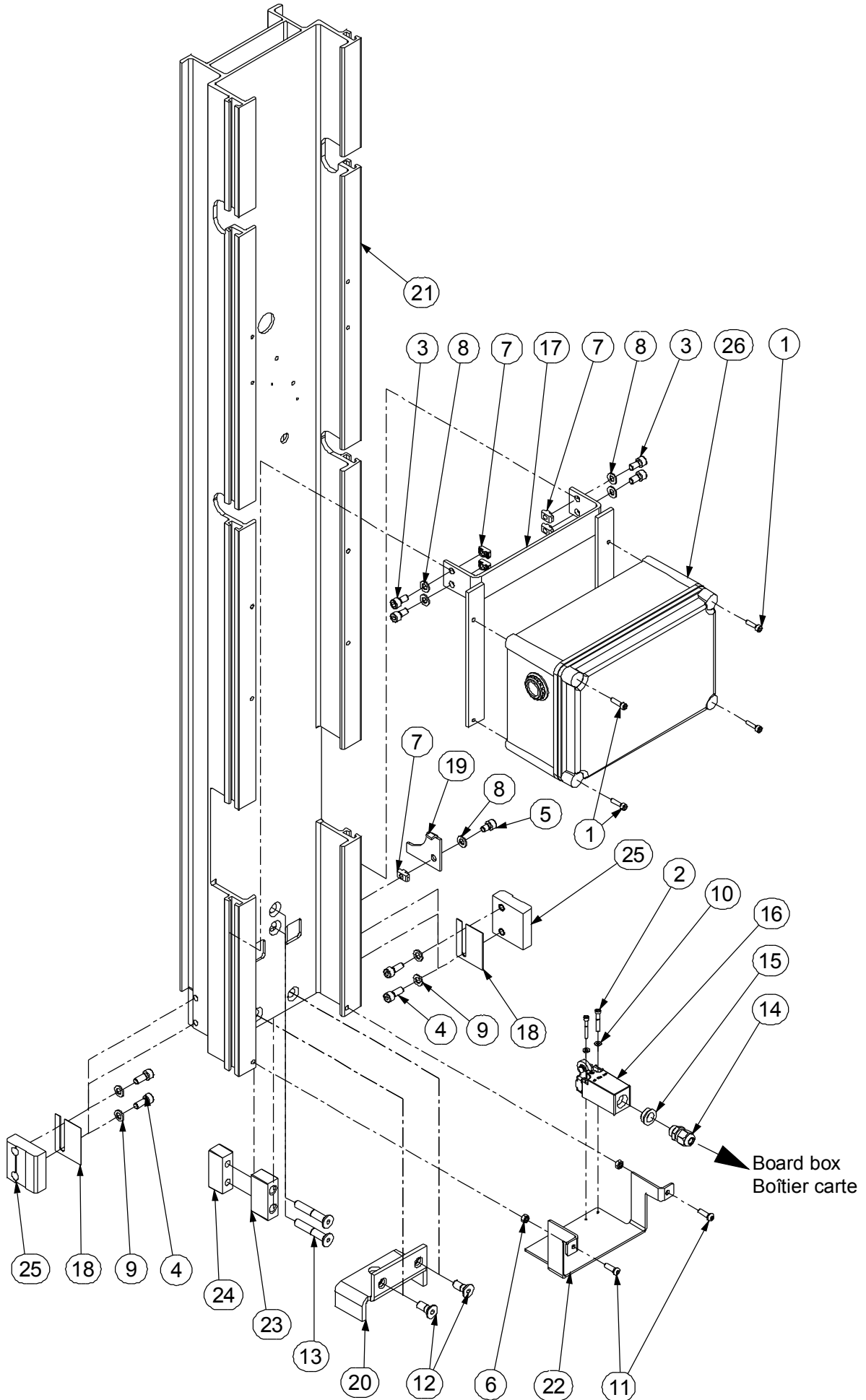

ISSUE DATE : 29/09/03

MAST 4 ASSEMBLY

ISSUE REL :

ASSEMBLY N° : SP0807 REV :
 N° ENSEMBLE :

ASSEMBLAGE MAT 4

1/1

DET REP	PART NUMBER REF.	SEE VIEW VOIR VUE	DESCRIPTION		REVISION	QTY QTE
1	000003		M05x16 8.8 SOCKET HEAD MACH SCREW	VIS CHC M05x16 8.8 BI FT		4
2	000007		M04x30 8.8 SOCKET HEAD CAPSCREW	VIS CHC M04x30 8.8 BI FP		2
3	000018		M08x16 8.8 SOCKET HEAD MACH SCREW	VIS CHC M08x16 8.8 BI FT		4
4	000058		M08x20 8.8 S SOCK. HEAD MACH SCREW	VIS CHC M08x20 8.8 BI FT TETE BASSE		4
5	000059		M08x12 8.8 S SOCK HEAD MACH SCREW	VIS CHC M08x12 8.8 BI FT TETE BASSE		1
6	110003		M06 GR. 8.8 LOCK NUT	ECROU FREIN M6 8.8 BI		2
7	110030		M08 RECTANGULAR BASE NUT	ECROU A EMBASE RECTANGULAIRE M08		5
8	120021		HELICAL SPRING LOCK WASHER Ø8	RONDELLE GROWER Ø8 BI		5
9	120014		M08 WASHER	RONDELLE M08 BI		4
10	120024		M04 LOCK WASHER	RONDELLE CONTACT M04 BI		2
11	130021		M06x20 8.8 ROUND HEAD MACH SCREW	VIS BOMBEE ULF M06x20 8.8 BI FT		2
12	130030		M010x25 10.9 COUNTERSUNK HEAD M. S	VIS FHC M10x25 10.9 BI FT		2
13	130032		M010x60 10.9 COUNTERSUNK HEAD M. S	VIS FHC M10x60 10.9 BI FT		2
14	210017		GLAND N°9	PRESSE ETOUPE N°9		1
15	250015		REDUCTION 13/9	REDUCTION 13/9		1
16	260030		2NC SWITCH	CAPTEUR 2NF		1
17	DL0721		BOARD BOX SUPPORT	SUPPORT BOITIER CARTE		1
18	ST1109		SHIM (4 sizes : see Service Manual)	CALE (4 épaisseurs: voir Manuel de Service)		2
19	ST1119		STEEL WIRE BRACKET	EQUERRE CABLE		1
20	ST1125		SPREADER BRACKET	EQUERRE PALONNIER		1
21	ST1633		MAST 4	MAT 4		1
22	ST2521		SWITCH HOLDER	SUPPORT CAPTEUR		1
23	US0296		SAFETY SPACER	ENTRETOISE DE SECURITE		1
24	US0297		SAFETY BLOCK	SECURITE PALONNIER		1
25	US0321		SLIDE BLOCK (4 sizes: see Service Manual)	PATIN (4 épaisseurs: voir Manuel de Service)		2
26		SP0803	BOARD BOX ASSEMBLY	ASSEMBLAGE BOITIER CARTE		1

SPARE PARTS ***PIECES DETACHEES***

SECTION 6

PLATFORM AND TABLE INSTALL INSTALLATION PANIER ET TABLETTE



PLATFORM AND TABLE INSTALL INSTALLATION PANIER ET TABLETTE

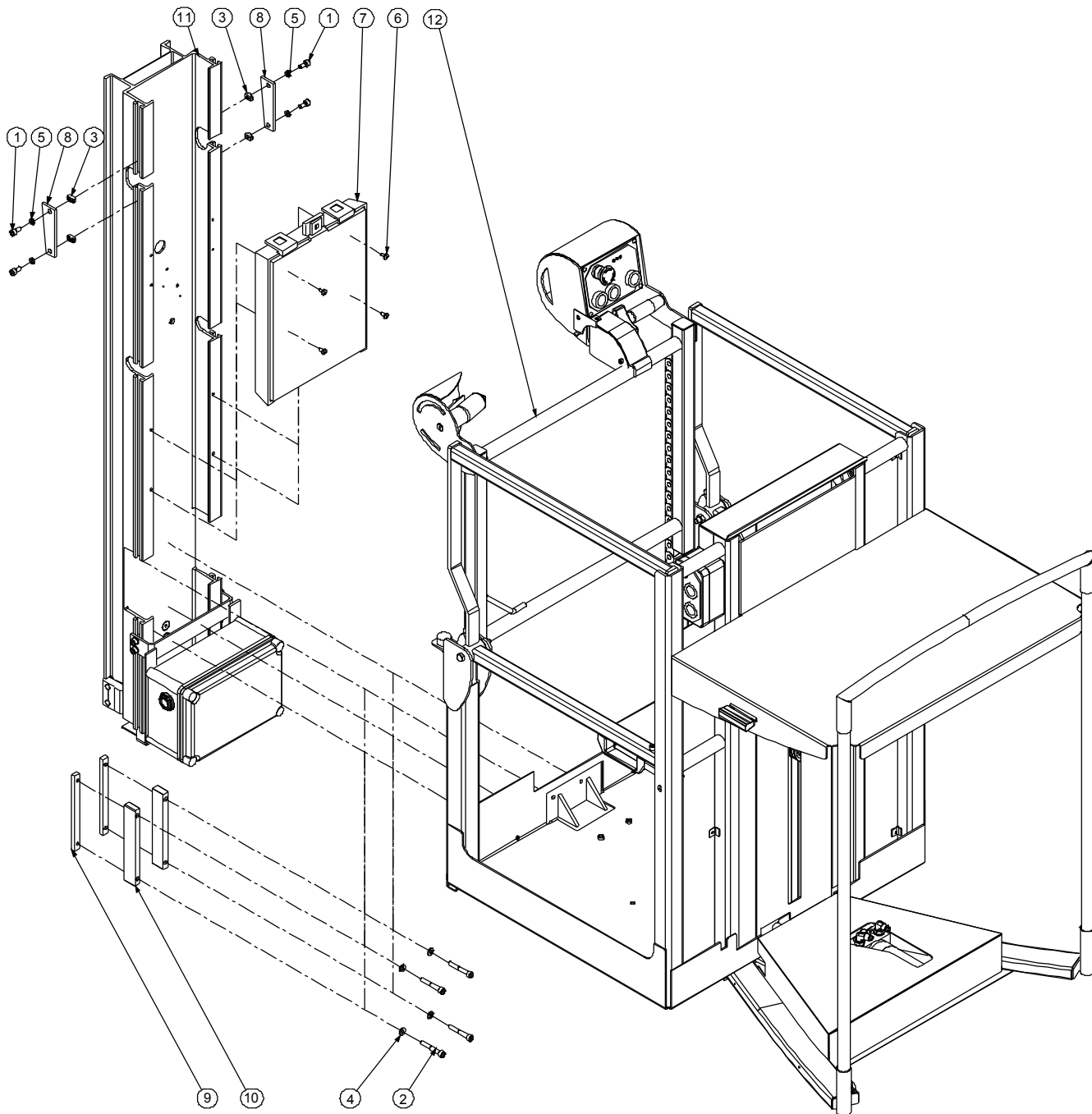

PLATFORM AND TABLE ASSEMBLY ASSEMBLAGE PANIER ET TABLETTE

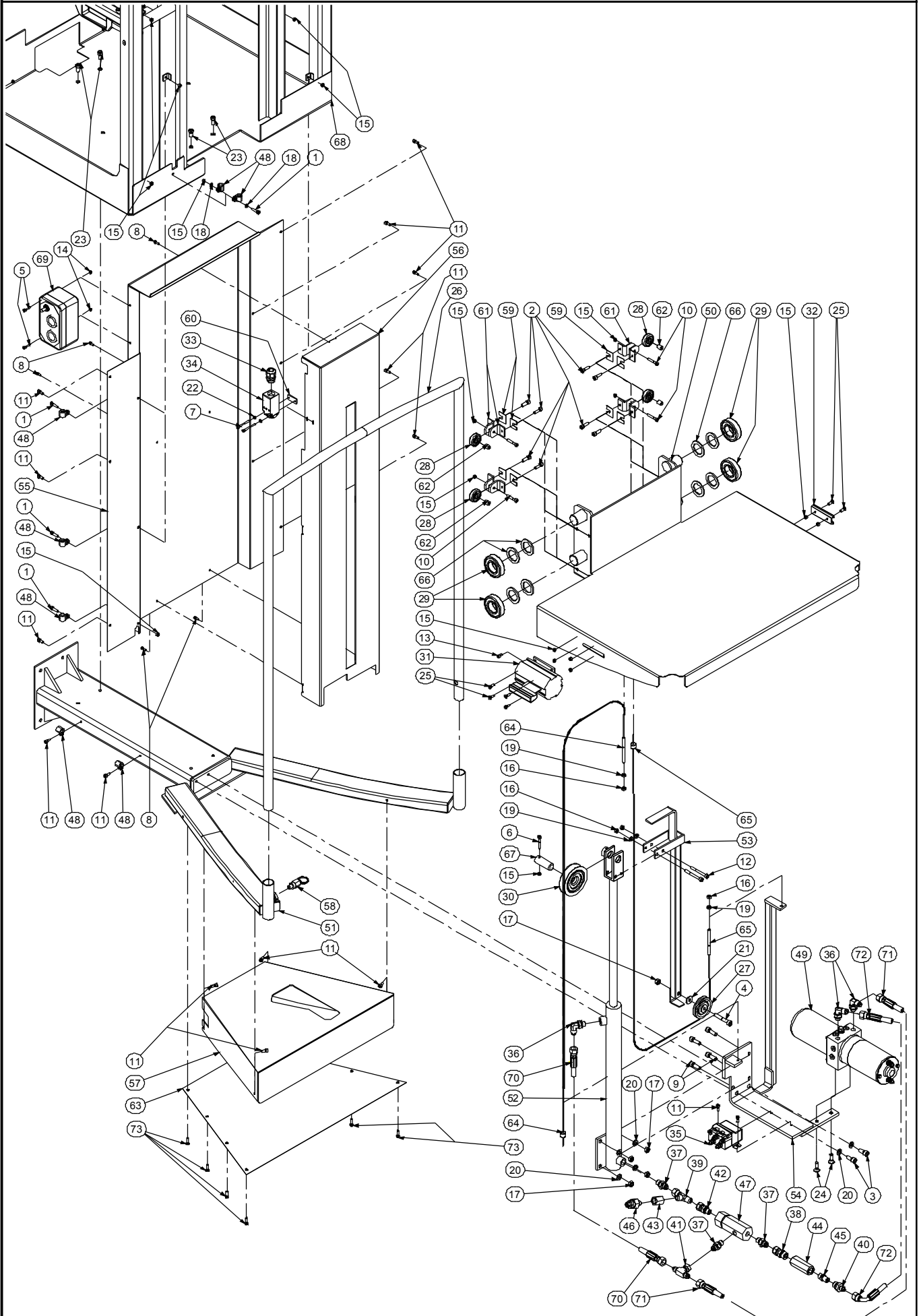

ISSUE DATE : 16/03/04

PLATFORM AND TABLE ASSEMBLY

ISSUE REL :

ASSEMBLY N° :
N° ENSEMBLE : SP0809 REV : A**ASSEMBLAGE PANIER ET TABLETTE**

1/2

DET REP	PART NUMBER REF.	SEE VIEW VOIR VUE	DESCRIPTION		R E V	QTY QTE
1	000003		M05x16 8.8 SOCKET HEAD MACH SCREW	VIS CHC M05x16 8.8 BI FT	A	4
2	000005		M06x20 8.8 SOCKET HEAD MACH SCREW	VIS CHC M06x20 8.8 BI FT		8
3	000006		M08x20 8.8 SOCKET HEAD MACH SCREW	VIS CHC M08x20 8.8 BI FT		2
4	000063		M08x45 8.8 S SOCKET HEAD CAPSCREW	VIS CHC M08x45 8.8 BI FT TETE BASSE		1
5	000020		M04x20 8.8 SOCKET HEAD MACH SCREW	VIS CHC M04x20 8.8 BI FT		2
6	000030		M05x35 8.8 SOCKET HEAD CAPSCREW	VIS CHC M05x35 8.8 ZI FP		1
7	000004		M04x35 8.8 SOCK. HEAD MACH. SCREW	VIS CHC M04x35 8.8 BI FT		2
8	000050		M04x10 8.8 SOCKET HEAD MACH SCREW	VIS CHC M04x10 8.8 BI FT		5
9	000053		M08x25 8.8 SOCKET HEAD MACH SCREW	VIS CHC M08x25 8.8 BI FT		4
10	000062		M05x30 8.8 SOCK HEAD MACHINE SCREW	Vis CHC M5x30 BI FT		4
11	000067		M05x12 8.8 SOCKET HEAD MACH SCREW	VIS CHC M05x12 8.8 BI FT		16
12	000073		M06x55 8.8 SOCKET HEAD CAPSCREW	VIS CHC M06x55 8.8 BI FP		2
13	000089		M05x08 8.8 SOCKET HEAD MACH SCREW	VIS CHC M05x08 8.8 BI FT	A	1
14	110001		M04 GR. 8.8 LOCK NUT	ECROU FREIN M4 8.8 BI		2
15	110002		M05 GR. 8.8 LOCK NUT	ECROU FREIN M5 8.8 BI	A	23
16	110003		M06 GR. 8.8 LOCK NUT	ECROU FREIN M6 8.8 BI		4
17	110004		M08 GR. 8.8 LOCK NUT	ECROU FREIN M8 8.8 BI		5
18	120002		M05 WASHER	RONDELLE M05 BI		2
19	120009		dD 06x14 LOCK WASHER	RONDELLE CONTACT dD 06x14 BI		4
20	120010		dD 08x18 LOCK WASHER	RONDELLE CONTACT dD 08x18 BI		6
21	120014		M08 WASHER	RONDELLE M08 BI		1
22	120024		M04 LOCK WASHER	RONDELLE CONTACT M04 BI		2
23	130013		M08x16 CROSS PAN HEAD CAPSCREW	VIS BOMBEE FENDUE M08x16 BI FT		4
24	130025		M08x25 10.9 COUNTERSUNK HEAD M. S.	VIS FHC M08x25 10.9 BI FT		2
25	130047		M5x16 8.8 COUNTERSUNK HEAD M SCR	VIS FHC M5x16 8.8 BI FT		6
26	140FP287		VELUX SUPPORT CROSSBAR	TRAVERSE SUPPORT VELUX		1
27	150028		BACKUP PULLEY	POULIE DE RAPPEL		1
28	150042		BEARING 6300 2RS	ROULEMENT 6300 2RS		4
29	150043		BEARING 6206 2RS	ROULEMENT 6206 2RS		4
30	150050		LIFTING PULLEY	POULIE DE LEVAGE		1
31	190066		ROLLER STRAP	SANGLE ENROULEUR		1
32	190067		ROLLER STRAP LOCK	SABOT DE FIXATION SANGLE		1
33	210062		GLAND N°13 Ø5 IP65	PRESSE ETOUPE N°13 Ø5 IP65		1
34	260016		SWITCH	CAPTEUR		1
35	260269		INVERTER RELAY	RELAIS INVERSEUR		1
36	300001		90° ELBOW MALE BSPP 1/4-MALE JIC 9/16	COUDE 90° Male BSPP 1/4 -Male JIC 9/16		3
37	300025		FITTING MALE BSPP1/4-MALE JIC9/16	RACCORD MALE BSPP1/4-MALE JIC9/16		3

PLATFORM AND TABLE ASSEMBLY ASSEMBLAGE PANIER ET TABLETTE

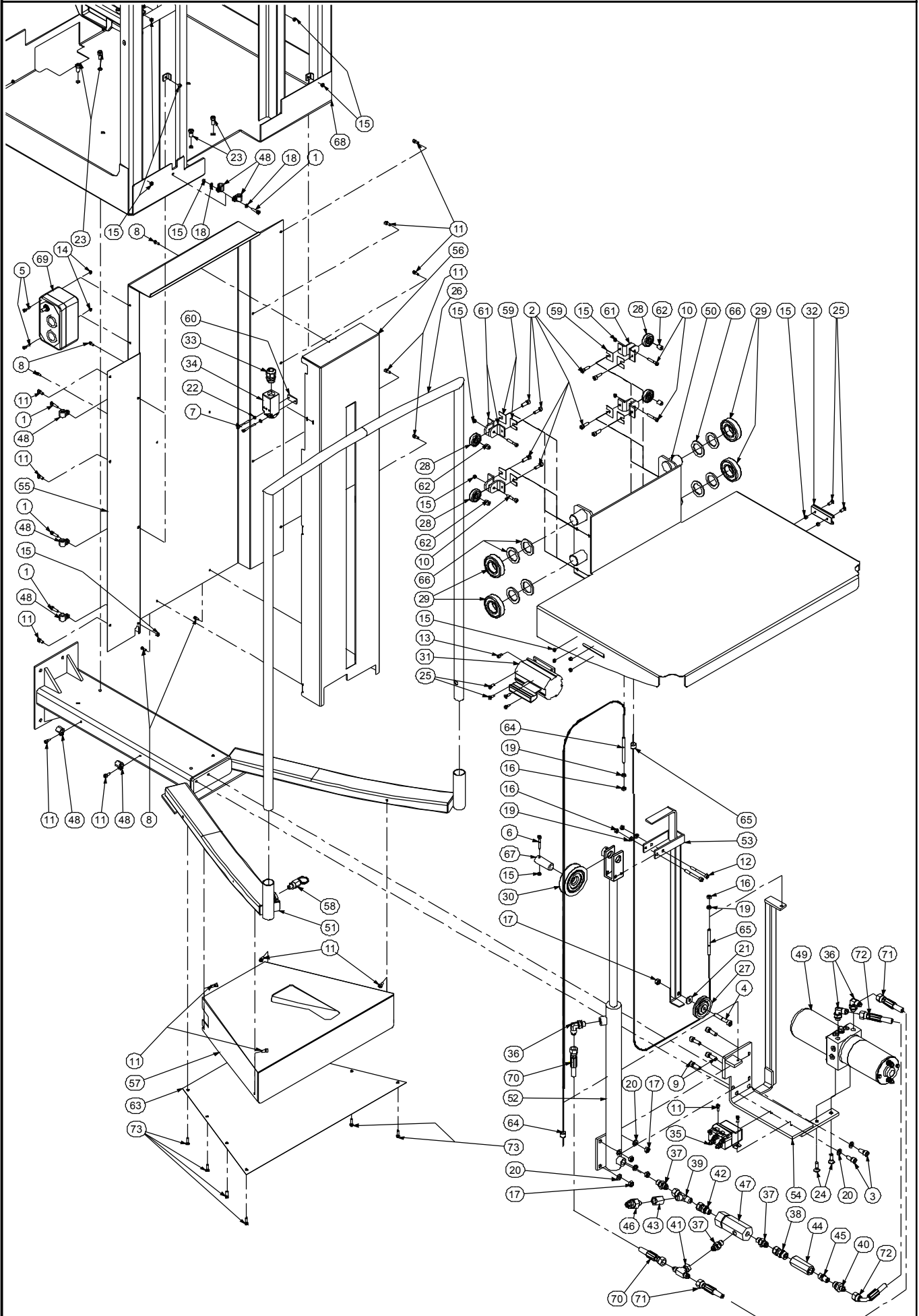

ISSUE DATE : 16/03/04

PLATFORM AND TABLE ASSEMBLY

ISSUE REL :

ASSEMBLY N° : SP0809 REV : A
N° ENSEMBLE :**ASSEMBLAGE PANIER ET TABLETTE**

2/2

DET REP	PART NUMBER REF.	SEE VIEW VOIR VUE	DESCRIPTION		R E V	QTY QTE
38	300027		FITTI. MALE BSPP3/8-FEM.JIC9/16 SWIVE	UNION MALE BSPP 3/8 -TOUR. JIC 9/16		1
39	300037		RUN TEE JIC 9/16 SWIVEL NUT	TE MALE JIC9/16-FEMELLE JIC9/16 TOUR.		1
40	300040		FITTING MALE BSPP3/8 MALE JIC9/16	RACCORD MALE BSPP3/8 MALE JIC9/16		1
41	300055		BRANCH TEE MALE JIC 9/16 SWIVEL NUT	TE Male JIC9/16 TOURNANT CENTRAL		1
42	300073		FITTING MALE BSPP 1/4-FEMALE JIC 9/16	RACC. MALE BSPP 1/4 -FEM. JIC 9/16		1
43	300099		PRESGAUGE UNION FEM BSPT1/4-JIC9/16	UNION MANO FEM BSPT 1/4 - JIC 9/16		1
44			EMPTY 310023	310023 VIDE		1
45	310042		FLOW CONTROL VALVE 3L/mn	REGULATEUR DE DEBIT 3L/mn		1
46	310050		PRESSURE SWITCH 10-20 BARS	PRESSOSTAT 10-20 BARS		1
47	320001		PILOT CHECK VALVE	CLAPET ANTI RETOUR PILOTE		1
48	400034		COLLAR	COLLIER		7
49	520054		R2K STEERING POWER UNIT	CENTRALE DE DIRECTION R2K		1
50	DL0711		TABLE	TABLETTE		1
51	DL0712		PLATFORM SUPPORT	SUPPORT PANIER		1
52	DL0713		TABLE RAISING CYLINDER	VERIN LEVAGE TABLETTE C=400		1
53	DL0714		BACK UP TABLE TABLE BAR	BARRE CABLE RAPPEL TABLETTE		1
54	DL0715		TABLE CYLINDER SUPPORT	SUPPORT VERIN TABLETTE		1
55	DL0718		INSIDE COVER	CAPOT INTERIEUR		1
56	DL0719		OUTSIDE COVER	CAPOT EXTERNE		1
57	DL0720		POWER UNIT COVER	CAPOT CENTRALE		1
58	SE0308		LOCKING PIN	INDEX		1
59	ST1698		MAST WHEEL HOLDER SHIM (th 1mm)	CALE SUPPORT ROUE DE MAT(ép: 1mm)		x
59	ST1699		MAST WHEEL HOLDER SHIM (th 0.8mm)	CALE SUPPORT ROUE DE MAT(ép: 0.8mm)		x
59	ST1700		MAST WHEEL HOLDER SHIM (th 0.5mm)	CALE SUPPORT ROUE DE MAT(ép: 0.5mm)		x
60	ST1971		STEERING SWITCH PLATE	CONTRE PLAQUE CAPTEUR DIRECTION		1
61	ST2790		BEARING BRACKET	EQUERRE DE ROULEMENT		8
62	ST2791		BEARING SPACER	ENTRETOISE ROULEMENT		4
63	ST2796		POWER UNIT COVER BOTTOM	FOND CAPOT CENTRALE		1
64	ST2803		TABLE LIFTING TABLE	CABLE LEVAGE TABLETTE		1
65	ST2804		TABLE BACK UP TABLE	CABLE RAPPEL TABLETTE		1
66	US0025		WASHER	RONDELLE AXE DE GALET		8
67	US0499		TABLE CYLINDER PIN	AXE VERIN TABLETTE		1
68		SP0810	PLATFORM ASSEMBLY	ASSEMBLAGE PANIER		1
69		SP0804	TABLE BOX ASSEMBLY	ASSEMBLAGE BOITIER TABLETTE		1
70	DF0147		HOSE (flexible) 1/4-PARKER 491-0065cm-JIC Fem 9/16-JIC Fem 9/16			1
71	DF0221		HOSE (flexible) 1/4-PARKER 491-0045cm-JIC Fem 9/16-JIC Fem 9/16			1
72	DF0282		HOSE (flexible) 1/4-PARKER 491-0025cm-JIC Fem 9/16-JIC Fem 9/16 90°			1
73	130010		M05x16 8.8 CROSS RECESSED PAN HEAD	VIS POELIER M05x16 8.8 BI FT	A	8

PLATFORM ASSEMBLY ASSEMBLAGE PANIER

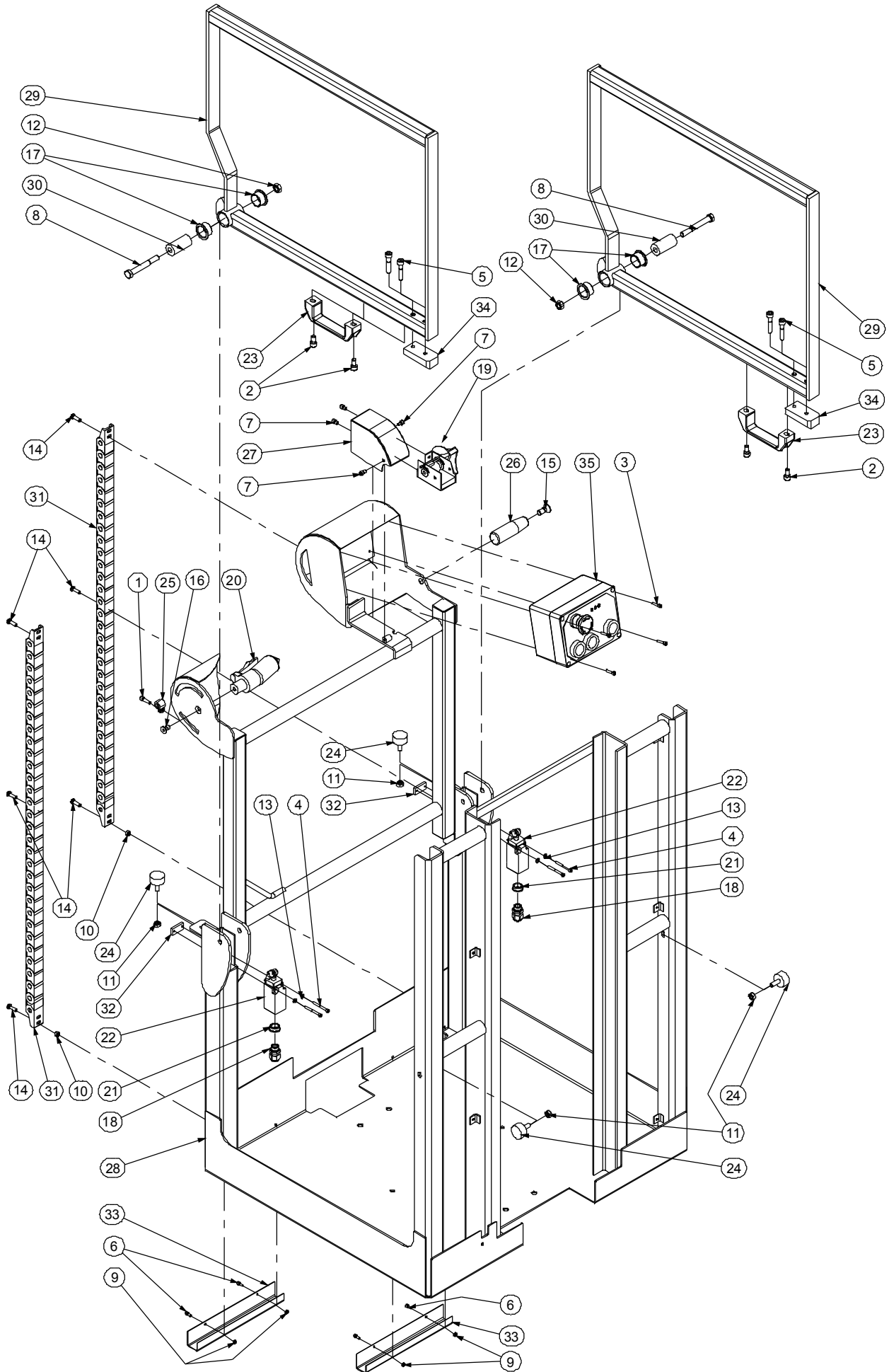

ISSUE DATE : 16/03/04

PLATFORM ASSEMBLY

ISSUE REL :

ASSEMBLAGE PANIERASSEMBLY N° :
N° ENSEMBLE : SP0810 REV : A

1/1

DET REP	PART NUMBER REF.	SEE VIEW VOIR VUE	DESCRIPTION		R E V	QTY QTE
1	000003		M05x16 8.8 SOCKET HEAD MACH SCREW	VIS CHC M05x16 8.8 BI FT		1
2	000018		M08x16 8.8 SOCKET HEAD MACH SCREW	VIS CHC M08x16 8.8 BI FT		4
3	000020		M04x20 8.8 SOCKET HEAD MACH SCREW	VIS CHC M04x20 8.8 BI FT		4
4	000032		M04x40 8.8 SOCKET HEAD CAPSCREW	VIS CHC M04x40 8.8 ZI FP		4
5	000043		M08x40 8.8 SOCKET HEAD MACH SCREW	VIS CHC M08x40 8.8 BI FT		4
6	000050		M04x10 8.8 SOCKET HEAD MACH SCREW	VIS CHC M04x10 8.8 BI FT		4
7	000089		M05x08 8.8 SOCKET HEAD MACH SCREW	VIS CHC M05x08 8.8 BI FT		4
8	100091		M10x80 8.8 HEX HEAD CAPSCREW	VIS H M10x80 8.8 BI FP	A	2
9	110001		M04 GR. 8.8 LOCK NUT	ECROU FREIN M4 8.8 BI		4
10	110003		M06 GR. 8.8 LOCK NUT	ECROU FREIN M6 8.8 BI	A	2
11	110004		M08 GR. 8.8 LOCK NUT	ECROU FREIN M8 8.8 BI		4
12	110005		M10 GR. 8.8 LOCK NUT	ECROU FREIN M10 8.8 BI		2
13	120024		M04 LOCK WASHER	RONDELLE CONTACT M04 BI		4
14	130021		M06x20 8.8 ROUND HEAD MACH SCREW	VIS BOMBEE ULF M06x20 8.8 BI FT	A	6
15	130030		M010x25 10.9 COUNTERSUNK HEAD M. S.	VIS FHC M10x25 10.9 BI FT		1
16	130053		M08x16 8.8 COUNTERSUNK HEAD M. S.	VIS FHC M08x16 8.8 BI FT		1
17	150039		FLANGE BUSHING Ø25 H16.5 DU	BAGUE EPAULEE Ø25 H16.5 DU		4
18	210017		GLAND N°9	PRESSE ETOUPE N°9		2
19	240087		CONTROL HANDLE	POIGNEE DE COMMANDE	A	1
20	240086		STEERING HANDLE	POIGNEE DE DIRECTION		1
21	250015		REDUCTION 13/9	REDUCTION 13/9		2
22	260182		SWITCH	CAPTEUR		2
23	400001		HANDLE	POIGNEE		2
24	400015		ELASTIC STOP	BUTEE ELASTIQUE		4
25	400034		COLLAR	COLLIER		1
26	400089		PLASTIC HANDLE	POIGNEE PLASTIQUE		1
27	DL0710		GPH COVER	CAPOT GPH		1
28	DL0716		PLATFORM GUARDRAIL	ARMATURE PANIER		1
29	DL0717		GATE	PORTILLON		2
30	FP148-017		Ddh 25x10.5x50 SPACER	ENTRETOISE Ddh 25x10.5x50		2
31	ST2810		POWER BRIDGE	CHAINE PORTE CABLES	A	2
32	ST1971		STEERING SWITCH PLATE	CONTRE PLAQUE CAPTEUR DIRECTION		2
33	ST2797		CABLES PROTECTION	PROTECTION CABLES		2
34	US0470		SLIDE BLOCK	PATIN		2
35		SP0802	UPPER CONTROL BOX ASSEMBLY	ASSEMBLAGE BOITIER HAUT		1

SPARE PARTS
PIECES DETACHEES

SECTION 7

DECALS INSTALL
INSTALLATION AUTOCOLLANTS



DECALS INSTALL INSTALLATION AUTOCOLLANTS

TOUCAN Duo		INSTRUCTIONS /CONSIGNES	LOAD/CHARGE	EMERGENCY /SECOURS
Belgium/Belgique	NL	AU1765	AU1766	AU1022
	F	AU1734	AU1735	AU0932
Dutch/Hollande	NL	AU1765	AU1766	AU1022
		PA0913		
Finland/Finlande	FIN	AU1798	AU1799	AU1019
		PA0926		
France	F	AU1734	AU1735	AU0932
		PA0899		
Germany/Allemagne Ausria/Autriche	D	AU1751	AU1752	AU1017
	A	PA0906		
Italy/Italie	I	AU1759	AU1760	AU1016
		PA0910		
Norway/Norvège	N	AU1784	AU1785	AU1783
		PA0919		
Poland/Pologne	PL	AU1795	AU1796	AU1794
		PA0922		
Spain/Espagne	E	AU1778	AU1777	AU1024
		PA0915		
Sweden/Suède	S	AU1780	AU1781	AU1030
		PA0916		
United Kingdom Royaume uni	GB	AU1745	AU1746	AU0923
		PA0905		

PAxxxx = COMPLETE KIT / JEU COMPLET

MANUFACTURER'S NAME PLATE

PLAQUE CONSTRUCTEUR

AU1733

DECALS INSTALL INSTALLATION AUTOCOLLANTS

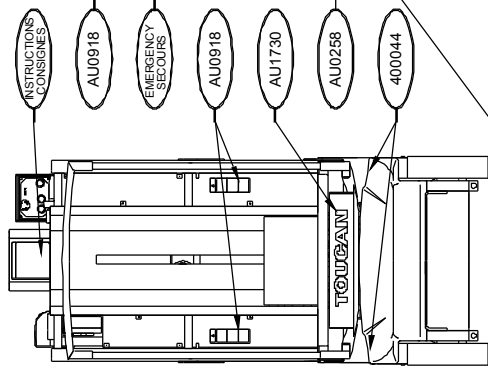
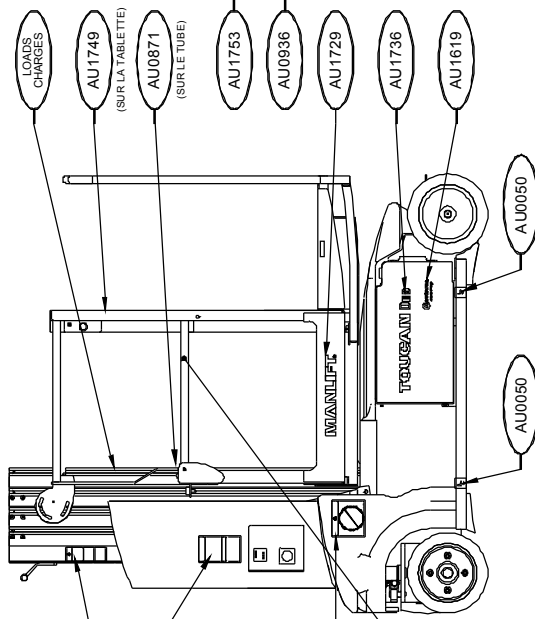
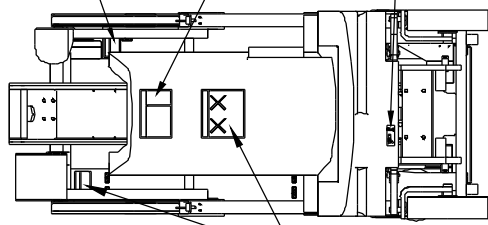
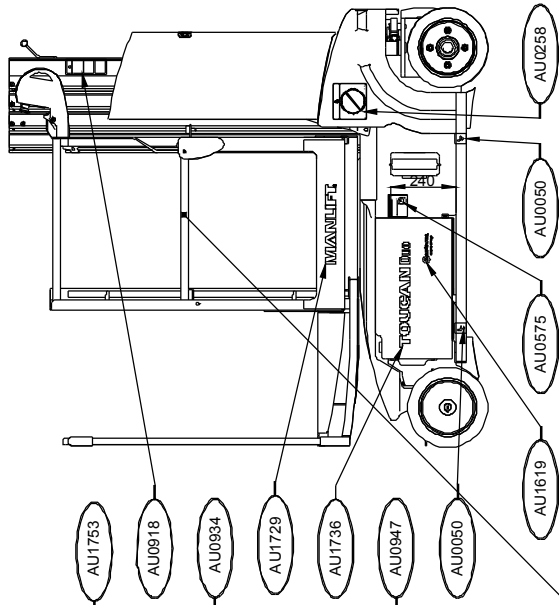

POSITIONNEMENT DES 4xAU1776 SUR LE PORTILLON COTE DROIT

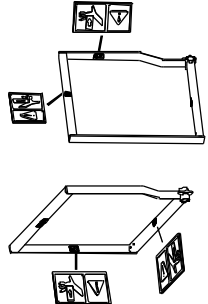

POSITIONNEMENT DES 4xAU1776 SUR LE PORTILLON COTE GAUCHE

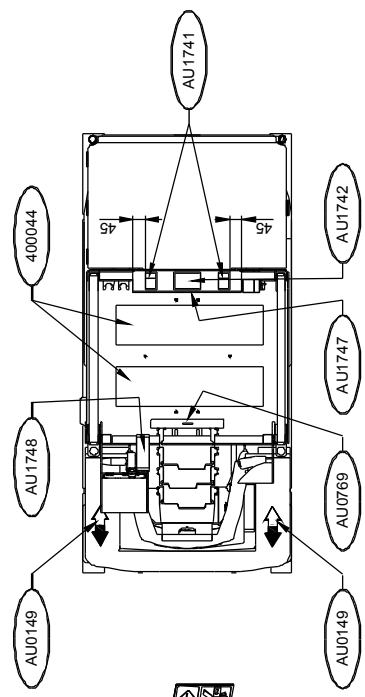
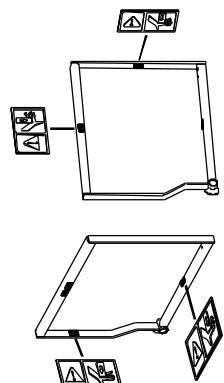

AU0934	1
AU0918	4
AU0871	1
AU0769	1
AU0575	1
AU0258	2
AU0149	2
AU0050	4
Repere	Nb

AU1741	2
AU1736	2
AU1730	1
AU1729	2
AU1619	2
AU0947	1
AU0936	1
Repere	Nb

400044	1,9 m
AU1776	8
AU1753	2
AU1749	1
AU1748	1
AU1747	1
AU1742	1
Repere	Nb

CROSS REFERENCE CHART

TABLEAU DE CORRESPONDANCE

	Pages	Main assembly Assemblage supérieur
520099	4-2	SP0811
Paxxxx	7	
PC0382	2-2	
PC0378	2-1	
RM0059	4-1	SP0811
RM0090	2-2-1	PC0354
RM0091	2-2-2	PC0354
SP0386	5-2	SP0806
SP0387	5-3	SP0806
SP0390	3	
SP0802	2-2-3	PC0354
SP0803	2-2-4	PC0354
SP0804	2-2-5	PC0354
SP0805	2-2-6	PC0354
SP0806	5	
SP0807	5-4	SP0806
SP0808	6	
SP0809	6-1	SP0808
SP0810	6-1-1	SP0809
SP0811	4	
SP0812	1	
SP0813	5-1	SP0806
SP0883	2-2-7	PC0354
ST1628	5-1-1	SP0813