



**MODEL
TOUCAN DUO**



**SPARE PARTS MANUAL
MANUEL DE PIÈCES DÉTACHÉES**

U.S.A.
JLG INDUSTRIES, INC
1 JLG Drive
McConnellsburg
PA 17233-9533
Tél : (717) 485-5161
Fax : (717) 485-6417

C.E.
JLG Industries,
Kilmartin Place,
Tannochside Park
Uddingston, Scotland G71 5PH
Tel : +44(0)1698 811005
Fax : +44(0)1698 811055

AUSTRALIA
JLG INDUSTRIE
P.O Box 972
11 Bolwarra Road
Port MacQuarie N.S.W. 44
Tel : 1 (065) 811111
Fax : 1 (065) 810122

FRANCE
Delta Manlift SAS
Z.I. «Guillaume mon amy»
BP 20 - 47400 TONNEINS
France
Tel : +33 553 84 85 11
Fax : +33 553 79 06 87

Updated : 10-2005

MA0321-05
English/French



DISTRIBUTOR STAMP / CACHET DISTRIBUTEUR

MACHINE SERIAL NUMBER :
NUMERO DE SERIE MACHINE :

Toucan Duo N° _____



Edition 10-2005
MA0321-05

SPARE PARTS

TO ORDER PARTS

IT IS ESSENTIAL TO SUPPLY THE FOLLOWING INFORMATION ON PARTS ORDERS SO THAT YOUR ORDER CAN BE PROPERLY EXPEDITED.

1. Give model and serial number of your machine. This information is found on the serial number plate mounted on the mast n°1 on the front of the platform.
2. Give complete information on the parts requested including the part number, description, and quantity.
3. Give the specific major unit for which the item is required, such as : frame, mast, cylinder, platform, control box, etc.
4. Give complete "ship-to" address and specify the exact method of shipment wanted.
5. Specify the urgency of the parts order by designating the priority (emergency or stock).

NOTE

When placing telephone order, please record with whom you spoke and date, so that follow-up telephone conversations are processed without confusion.

PIECES DETACHEES

POUR PASSER COMMANDE

AFIN QUE VOTRE COMMANDE SOIT CORRECTEMENT TRAITEE, IL EST NECESSAIRE DE FOURNIR LES INFORMATIONS SUIVANTES SUR LE BON DE COMMANDE.

1. Noter le modèle et le numéro de série de votre machine. Ces informations se trouvent sur la plaque constructeur qui est fixée sur l'avant de la machine, sur l'élément de mât n°1.
2. Noter entièrement les renseignements sur les articles en commande : référence de la pièce, description et quantité.
3. Indiquer l'unité principale pour laquelle la pièce est commandée : châssis, mât, vérin, plate-forme, boîtier de commande, etc...
4. Noter l'adresse complète du destinataire et indiquer le mode d'expédition souhaité.
5. Spécifier l'urgence des pièces commandées en indiquant leur priorité (urgence ou stock).

NOTE

Si vous passez une commande téléphonique, noter le nom de votre interlocuteur et la date afin que le suivi de votre entretien se fasse sans confusion.

TOUCAN DUO

UPPER CONTROL BOX
BOITIER HAUT
SECTION 2-2-3

PLATFORM
PANIER
SECTION 6-2

TABLE BOX
BOITIER TABLETTE
SECTION 2-2-5

SHELF
TABLETTE
SECTION 6-1

MAST
MAT
SECTION 5

BOARD BOX
BOITIER CARTE
SECTION 2-2-4

DECALS
AUTOCOLLANTS
SECTION 7

LOWER CONTROL BOX
BOITIER BAS
SECTION 2-2-6

COVERS
CAPOTS
SECTION 1

STEERING WHEEL
ROUE DIRECTRICE
SECTION 2-2-6

FRAME
CHASSIS
SECTION 4

CHARGER
CHARGEUR
SECTION 4

BATTERY
BATTERIE
SECTION 4

DRIVING WHEEL
ROUE MOTRICE
SECTION 4

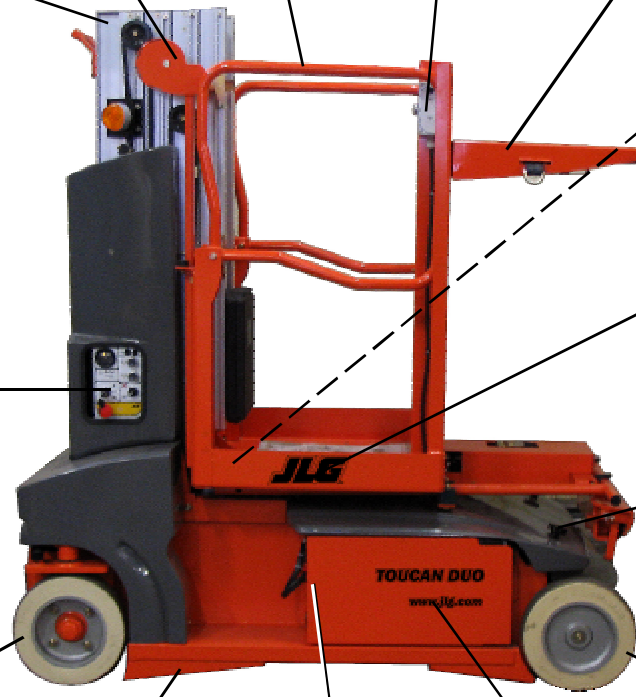

TABLE OF CONTENTS		TABLE DES MATIERES	
COVERS INSTALL	1	INSTALLATION CAPOTS	1
LOWER CONTROL BOX COVER OPTION	1-1	OPTION COUVERCLE BOITIER BAS	1-1
ELECTRICAL INSTALL	2	INSTALLATION ELECTRIQUE	2
POWER CIRCUIT	2-1	CIRCUIT DE PUISSANCE	2-1
CONTROL CIRCUIT	2-2	CIRCUIT DE COMMANDE	2-2
MATE-N-LOK CONNECTORS	2-2-1	CONNECTEURS MATE-N-LOK	2-2-1
CONNECTORS ON HARNESS ASSEMBLY	2-2-2	CONNECTEURS SUR FAISCEAUX	2-2-2
UPPER CONTROL BOX ASSEMBLY	2-2-3	ASSEMBLAGE BOITIER HAUT	2-2-3
BOARD BOX ASSEMBLY	2-2-4	ASSEMBLAGE BOITIER CARTE	2-2-4
TABLE BOX ASSEMBLY	2-2-5	ASSEMBLAGE BOITIER TABLETTE	2-2-5
LOWER CONTROL BOX ASSEMBLY	2-2-6	ASSEMBLAGE BOITIER BAS	2-2-6
LOWER CONTROL BOX WITH HOURMETER	2-2-7	BOITIER BAS AVEC HORAMETRE	2-2-7
MASTS ON FRAME INSTALL	3	INSTALLATION MATS SUR CHASSIS	3
FRAME INSTALL	4	INSTALLATION CHASSIS	4
CHARGER CONNECTOR	4-1	PRISE CHARGEUR	4-1
COMPLETE POWER UNIT 1.25cc	4-2	CENTRALE COMPLETE 1.25cm ³	4-2
MASTS INSTALL	5	INSTALLATION MATS	5
MAST 1 ASSEMBLY	5-1	ASSEMBLAGE MAT 1	5-1
MAST CYLINDER	5-1-1	VERIN DE MAT	5-1-1
MAST 2 ASSEMBLY	5-2	ASSEMBLAGE MAT 2	5-2
MAST 3 ASSEMBLY	5-3	ASSEMBLAGE MAT 3	5-3
MAST 4 ASSEMBLY	5-4	ASSEMBLAGE MAT 4	5-4
PLATFORM AND TABLE INSTALL	6	INSTALLATION PANIER ET TABLETTE	6
SHELF ASSEMBLY	6-1	ASSEMBLAGE TABLETTE	6-1
PLATFORM ASSEMBLY	6-2	ASSEMBLAGE PANIER	6-2
DECALS INSTALL	7	INSTALLATION AUTOCOLLANTS	7
CROSS REFERENCE CHART	LAST PAGE	TABEAU DE CORRESPONDANCE	DERNIERE PAGE

SPARE PARTS
PIECES DETACHEES

SECTION 1

COVERS INSTALL.
INSTALLATION CAPOTS.



COVERS INSTALL INSTALLATION CAPOTS

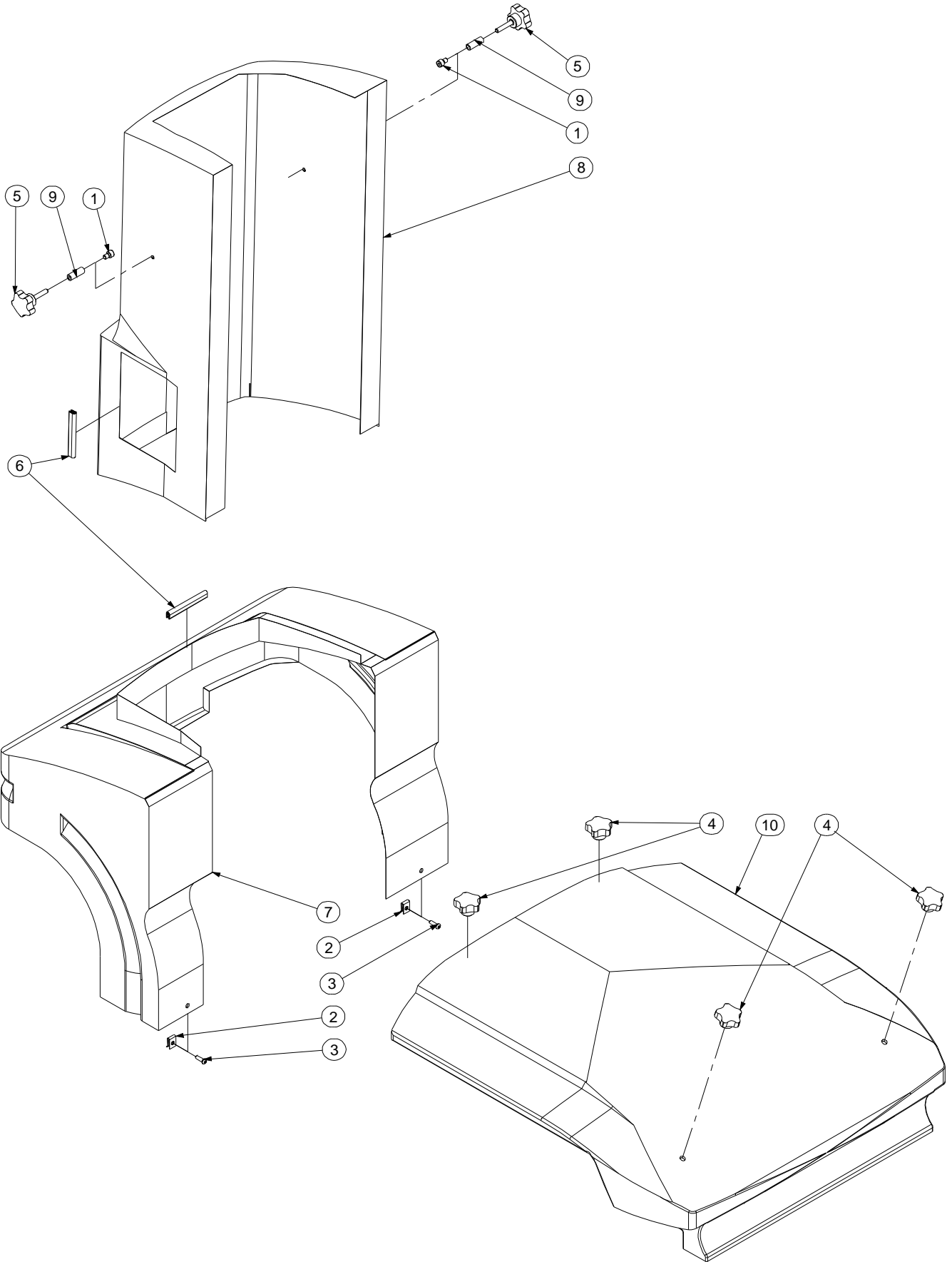

ISSUE DATE : 05/01/05

LOWER CONTROL BOX COVER OPTION

ISSUE REL :

ASSEMBLY N° : OPS482 REV :
 N° ENSEMBLE :

OPTION CAPOT BOITIER BAS

1/1

DET REP	PART NUMBER REF.	SEE VIEW VOIR VUE	DESCRIPTION		R E V	QTY QTE
1	000067		M05x12 8.8 SOCKET HEAD MACH SCREW	VIS CHC M05x12 8.8 BI FT		4
2	110002		M05 GR. 8.8 LOCK NUT	ECROU FREIN M5 8.8 BI		4
3	110003		M06 GR. 8.8 LOCK NUT	ECROU FREIN M6 8.8 BI		2
4	120002		M05 WASHER	RONDELLE M05 BI		4
5	120009		dD 06x14 LOCK WASHER	RONDELLE CONTACT dD 06x14 BI		2
6	130002		M06x20 6.8 ROUND HEAD MACH SCREW	VIS BOMBEE M06x20 6.8 BI FT		2
7	190032		FEMALE HINGE	PAUMELLE FEMELLE		1
8	190033		MALE HINGE	PAUMELLE MALE		1
9	190037		ROTARY LATCH	LOQUET		1
10	ST2904		COVER SUPPORT	SUPPORT COUVERCLE		1
11	ST2905	Duo	CONTROL BOX COVER	COUVERCLE BOITIER BAS		1
11	ST2906	Junior	CONTROL BOX COVER	COUVERCLE BOITIER BAS		1

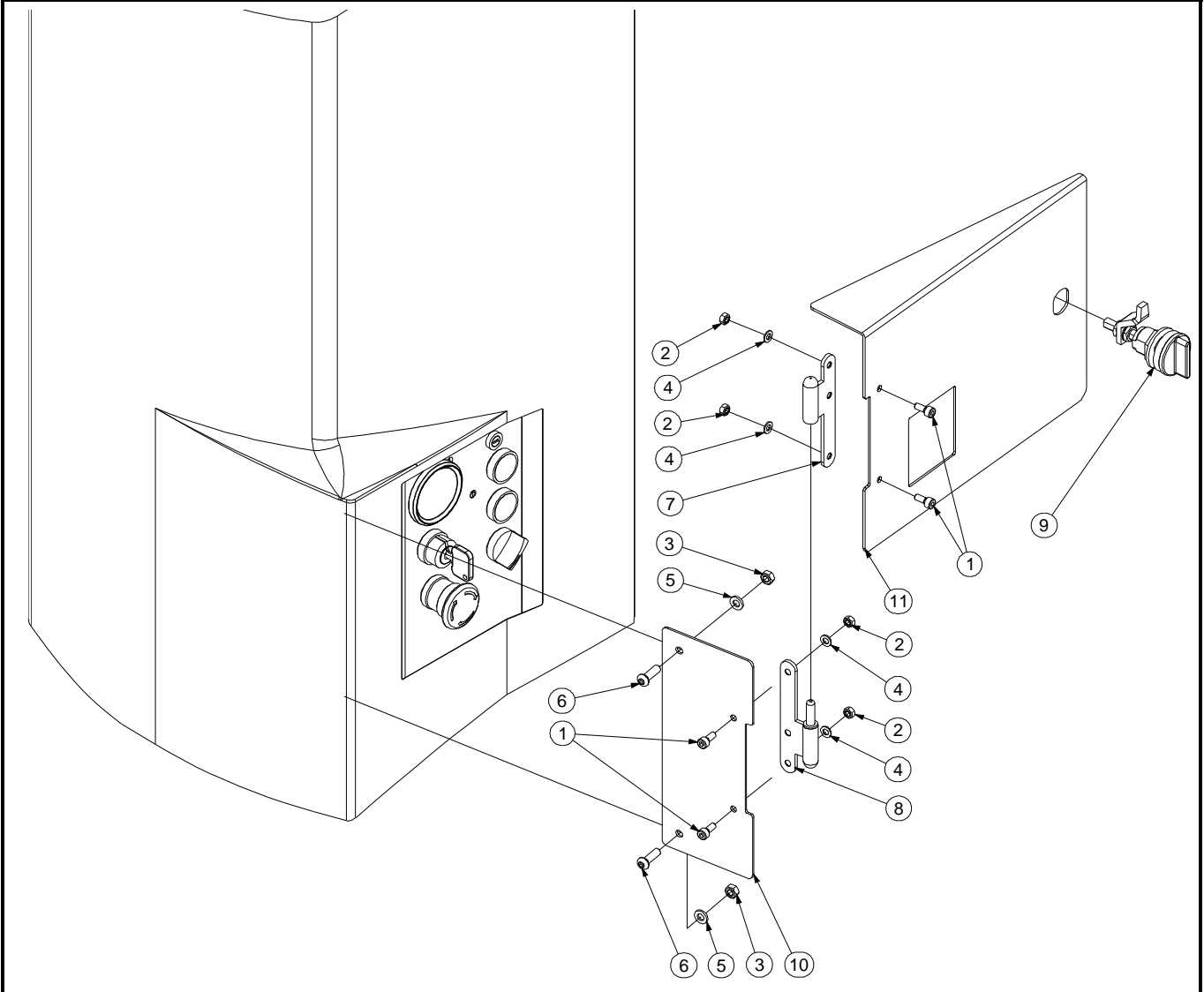

SPARE PARTS
PIECES DETACHEES

SECTION 2

ELECTRICAL INSTALL.
INSTALLATION ELECTRIQUE.



POWER CIRCUIT CIRCUIT DE PUISSANCE

**GRAISSER LES DEUX COSSES DE CHAQUE BATTERIE APRES LES AVOIR SERREES
GREASE BOTH TERMINALS ON EACH BATTERY AFTER THEY ARE TIGHTENED**

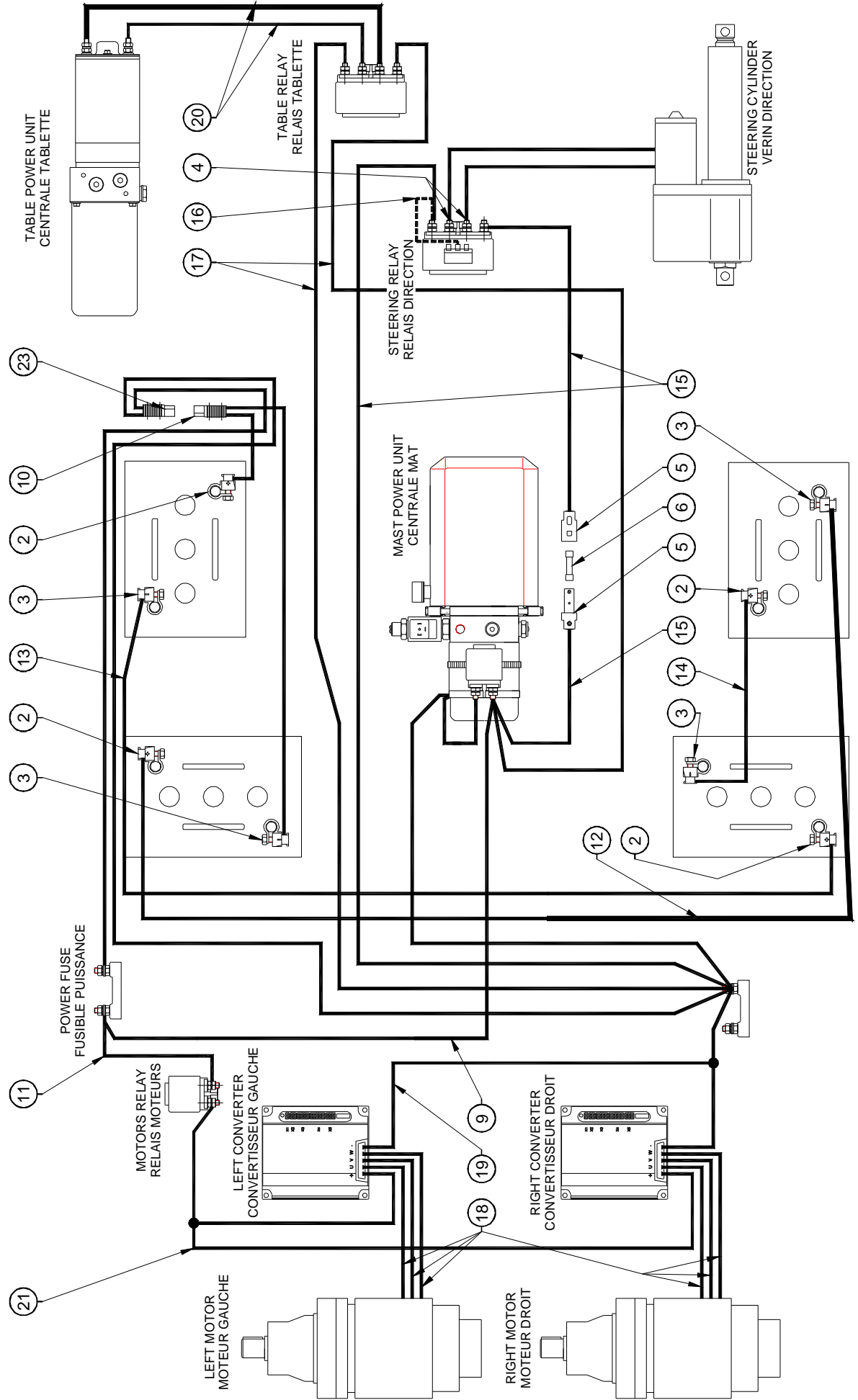

ISSUE DATE : 05/10/05

POWER ELECTRICAL INSTALL

ISSUE REL :

ASSEMBLY N° : PC0378 REV : A
 N° ENSEMBLE :

**INSTALLATION ELECTRIQUE DE
 PUISSANCE**

1/1

DET REP	PART NUMBER REF.	SEE VIEW VOIR VUE	DESCRIPTION		R E V	QTY QTE
1			NOT REQUIRED	NON REQUIS		
2	250028		BATTERIE TERMINAL +	COSSE + BATTERIE		4
3	250029		BATTERIE TERMINAL -	COSSE - BATTERIE		4
4	250096		M06 EYELET TERMINAL 4-6mm²	COSSE A ŒIL ISOLEE M6 - 4-6mm²		2
5	260007		FUSE HOLDER	PORTE FUSIBLE		1
6	260175		FUSE 16A	FUSIBLE 16A		1
7			NOT REQUIRED	NON REQUIS		
8			NOT REQUIRED	NON REQUIS		
9	PC0088		CABLE ASSEMBLY	CABLE ELECTRIQUE		1
10	PC0092		CABLE ASSEMBLY	CABLE ELECTRIQUE		1
11	PC0093		CABLE ASSEMBLY	CABLE ELECTRIQUE		1
12	PC0094		CABLE ASSEMBLY	CABLE ELECTRIQUE		1
13	PC0095		CABLE ASSEMBLY	CABLE ELECTRIQUE		1
14	PC0096		CABLE ASSEMBLY	CABLE ELECTRIQUE		1
15	PC0365		HARNESS ASSY-FRONT OF FRAME	FAISCEAU AVANT CHASSIS		1
16	PC0368		NEGATIVE BATTERY JUMPER	PONT NEGATIF BATTERIE		1
17	PC0369		CABLE ASSEMBLY	CABLE ELECTRIQUE		1
18	PC0370		CABLE ASSEMBLY	CABLE ELECTRIQUE		6
19	PC0371		CABLE ASSEMBLY	CABLE ELECTRIQUE	A	1
20	PC0372		CABLE ASSEMBLY	CABLE ELECTRIQUE		2
21	PC0373		CABLE ASSEMBLY	CABLE ELECTRIQUE		1
22			NOT REQUIRED	NON REQUIS	A	
23	PC0375		CABLE ASSEMBLY	CABLE ELECTRIQUE		1

CONTROL CIRCUIT CIRCUIT DE COMMANDE

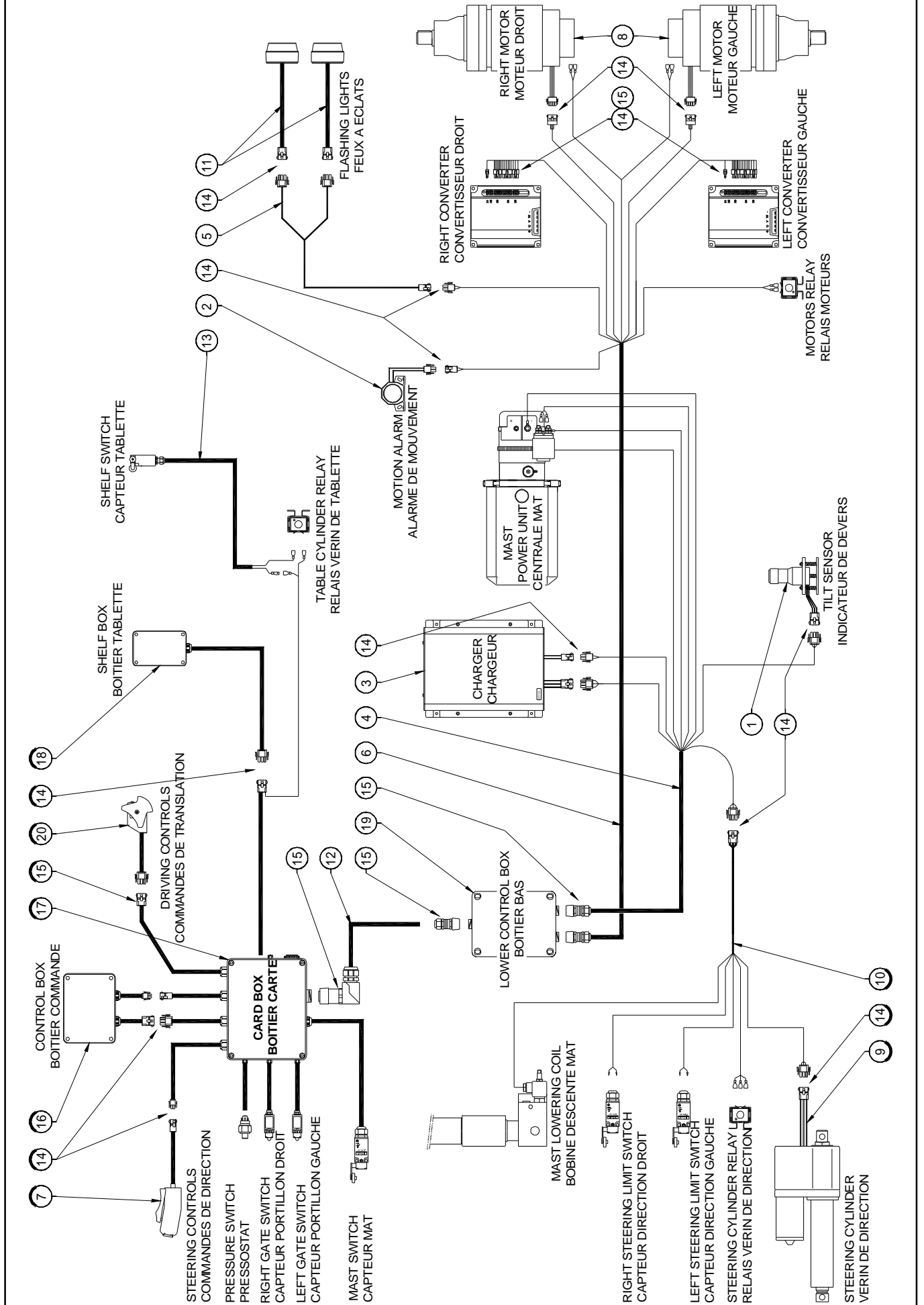

MATE-N-LOK CONNECTORS CONNECTEURS MATE-N-LOK

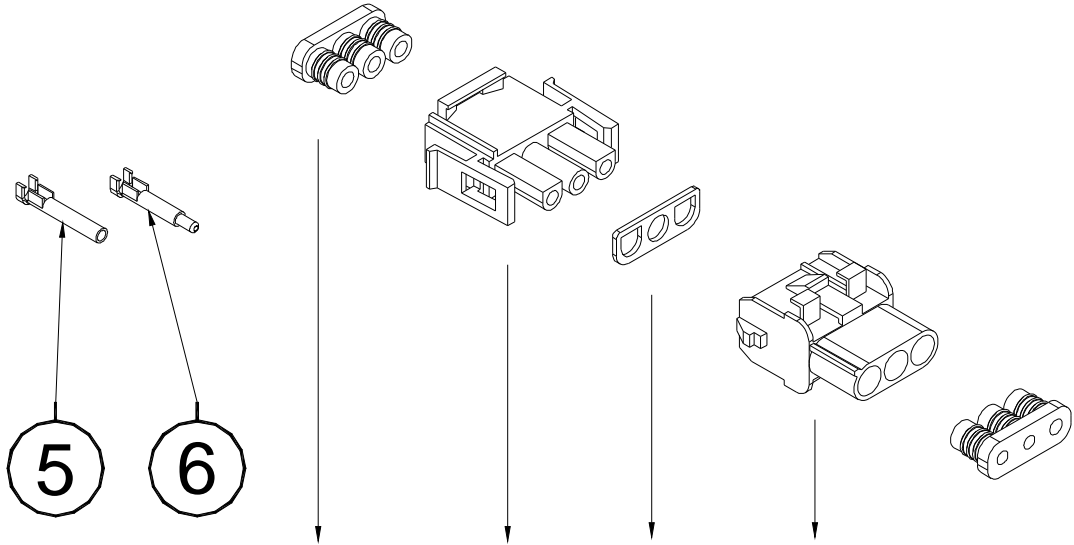

	26	23	25	24
	10	7	9	8
	14	11	13	12
	18	15	17	16
	4	1	3	2
	22	19	21	20

ISSUE DATE : 28/04/03

MATE-N-LOK CONNECTORS

ISSUE REL :

CONNECTEURS MATE-N-LOK

ASSEMBLY N° : RM0090 REV :
N° ENSEMBLE :

1/1

DET REP	PART NUMBER REF.	SEE VIEW VOIR VUE	DESCRIPTION		REV	QTY QTE
1	210029		9 POSITIONS PLUG HOUSING "MNL"	CONNECTEUR MALE 9 COSSES "MNL"		
2	210030		9 POSITIONS CAP HOUSING "MNL"	CONNECTEUR FEMELLE 9 COSSES "MNL"		
3	210031		9 POSITIONS INTERFACE SEAL	JOINT INTERFACE CONNECTEUR 9 CTS		
4	210032		9 POSITIONS WIRE SEAL	JOINT ARRIERE CONNECTEUR 9 CTS		
5	210033		SOCKET CONTACT "MATE-N-LOK"	CONTACT FEMELLE "MATE-N-LOK"		
6	210034		PIN CONTACT "MATE-N-LOK"	CONTACT MALE "MATE-N-LOK"		
7	250140		3 POSITIONS "MNL" PLUG HOUSING	CONNECTEUR MALE 3 CONTACTS "MNL"		
8	250141		3 POSITIONS "MNL" CAP HOUSING	CONNECTEUR FEMELLE 3 CTS "MNL"		
9	250143		3 POSITIONS INTERFACE SEAL	JOINT INTERFACE CONNECTEUR 3 CTS		
10	250144		3 POSITIONS WIRE SEAL	JOINT ARRIERE CONNECTEUR 3 CTS		
11	250145		4 POSITIONS "MNL" PLUG HOUSING	CONNECTEUR MALE 4 CONTACTS "MNL"		
12	250146		4 POSITIONS "MNL" CAP HOUSING	CONNECTEUR FEMELLE 4 CTS "MNL"		
13	250148		4 POSITIONS INTERFACE SEAL	JOINT INTERFACE CONNECTEUR 4 CTS		
14	250149		4 POSITIONS WIRE SEAL	JOINT ARRIERE CONNECTEUR 4 CTS		
15	250150		6 POSITIONS "MNL" PLUG HOUSING	CONNECTEUR MALE 6 CONTACTS "MNL"		
16	250151		6 POSITIONS "MNL" CAP HOUSING	CONNECTEUR FEMELLE 6 CTS "MNL"		
17	250153		6 POSITIONS INTERFACE SEAL	JOINT INTERFACE CONNECTEUR 6 CTS		
18	250154		6 POSITIONS WIRE SEAL	JOINT ARRIERE CONNECTEUR 6 CTS		
19	250155		12 POSITIONS "MNL" PLUG HOUSING	CONNECTEUR MALE 12 CONTACTS "MNL"		
20	250156		12 POSITIONS "MNL" CAP HOUSING	CONNECTEUR FEMELLE 12 CTS "MNL"		
21	250158		12 POSITIONS INTERFACE SEAL	JOINT INTERFACE CONNECTEUR 12 CTS		
22	250159		12 POSITIONS WIRE SEAL	JOINT ARRIERE CONNECTEUR 12 CTS		
23	250193		2 POSITIONS "MNL" PLUG HOUSING	CONNECTEUR MALE 2 CONTACTS "MNL"		
24	250194		2 POSITIONS "MNL" CAP HOUSING	CONNECTEUR FEMELLE 2 CTS "MNL"		
25	250195		2 POSITIONS INTERFACE SEAL	JOINT INTERFACE CONNECTEUR 2 CTS		
26	250196		2 POSITIONS WIRE SEAL	JOINT ARRIERE CONNECTEUR 2 CTS		

CONNECTORS ON HARNESS ASSEMBLY CONNECTEURS SUR FAISCEAUX

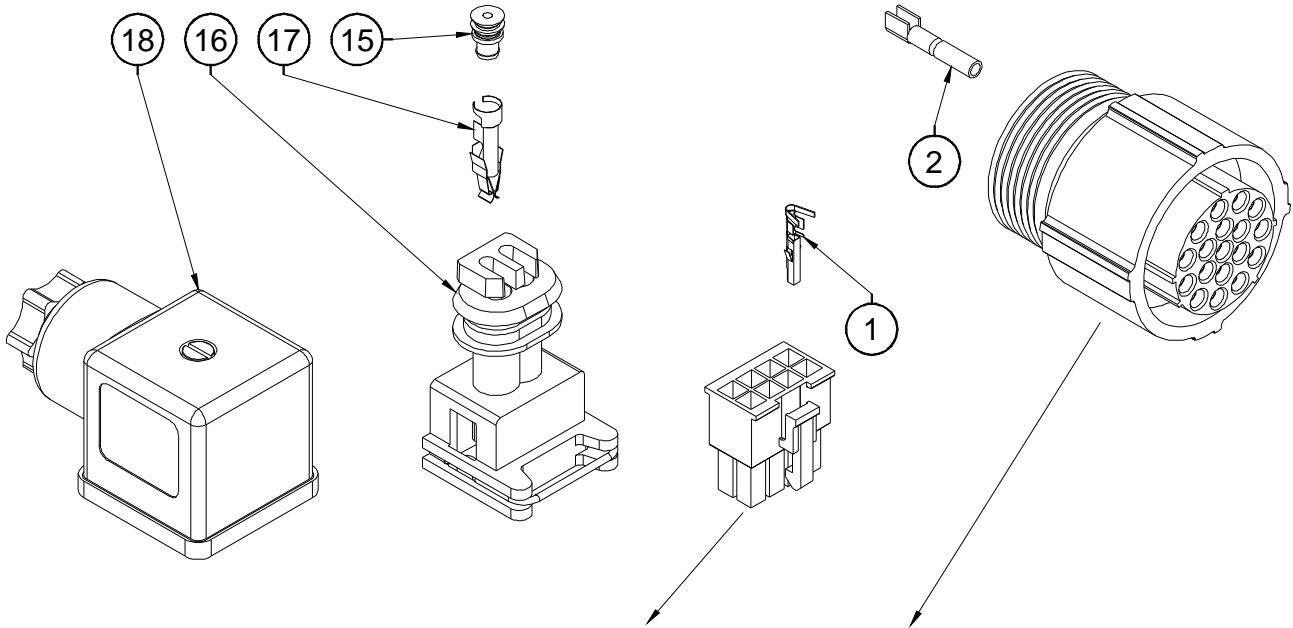

Number of pins Nombre de contacts	PART NUMBER / REP		GLAND / PE	
	MOLEX	FCI		
2	(3)			
4	(4)			
6	(5)			
8	(6)		180°	90°
9		(12)	(22)	
10	(7)			
12	(8)			
14	(9)			
16	(10)			
18	(24)	(13)	(21)	(23)
22	(25)			
24	(11)			
26		(14)	(20)	(19)

ISSUE DATE : 12/05/03

CONNECTORS ON HARNESS ASSEMBLY

ISSUE REL :

ASSEMBLY N° : RM0091 REV :
N° ENSEMBLE :

CONNECTEURS SUR FAISCEAUX

1/1

DET REP	PART NUMBER REF.	SEE VIEW VOIR VUE	DESCRIPTION		R E V	QTY QTE
1	250190		SOCKET CONTACT "MOLEX MINI-FIT"	CONTACT FEMELLE "MOLEX MINI-FIT"		
2	260130		SOCKET CONTACT	CONTACT A SERTIR FEMELLE		
3	250206		2 POS. "MOLEX MINI-FIT" PLUG HOUSING	CONNECTEUR "MOLEX MINI-FIT" 2 CTS		
4	250199		4 POS. "MOLEX MINI-FIT" PLUG HOUSING	CONNECTEUR "MOLEX MINI-FIT" 4 CTS		
5	250200		6 POS. "MOLEX MINI-FIT" PLUG HOUSING	CONNECTEUR "MOLEX MINI-FIT" 6 CTS		
6	250189		8 POS. "MOLEX MINI-FIT" PLUG HOUSING	CONNECTEUR "MOLEX MINI-FIT" 8 CTS		
7	250201		10 POS. "MOLEX MINI-FIT" PLUG HOUSING	CONNECTEUR "MOLEX MINI-FIT" 10 CTS		
8	250202		12 POS. "MOLEX MINI-FIT" PLUG HOUSING	CONNECTEUR "MOLEX MINI-FIT" 12 CTS		
9	250203		14 POS. "MOLEX MINI-FIT" PLUG HOUSING	CONNECTEUR "MOLEX MINI-FIT" 14 CTS		
10	250204		16 POS. "MOLEX MINI-FIT" PLUG HOUSING	CONNECTEUR "MOLEX MINI-FIT" 16 CTS		
11	250205		24 POS. "MOLEX MINI-FIT" PLUG HOUSING	CONNECTEUR "MOLEX MINI-FIT" 24 CTS		
12	260177		9 POSITIONS SOCKET HOUSING	CONNECTEUR 9 CONTACTS		
13	260168		18 POSITIONS SOCKET HOUSING	CONNECTEUR 18 CONTACTS		
14	260128		26 POSITIONS SOCKET HOUSING	CONNECTEUR 26 CONTACTS		
15	260132		WIRE SEAL	JOINT DE CONNECTEUR		
16	260136		AMP TIMER CAP HOUSING	CONNECTEUR AMP TIMER		
17	260137		RECEPTACLE CONTACT	CONTACT		
18	900087		CONNECTOR DIN43650-A	CONNECTEUR DIN43650-A		
19	210020		90° CABLE GLAND N°29	PRESSE ETOUPE COUDE N°29		
20	260129		CABLE GLAND N°29	PRESSE ETOUPE N°29		
21	260169		CABLE GLAND N°21	PRESSE ETOUPE N°21		
22	260170		CABLE GLAND N°16	PRESSE ETOUPE N°16		
23	260221		90° CABLE GLAND N°21	PRESSE ETOUPE COUDE N°21		
24	250216		18 POS. "MOLEX MINI-FIT" PLUG HOUSING	CONNECTEUR "MOLEX MINI-FIT" 18 CTS		
25	250217		22 POS. "MOLEX MINI-FIT" PLUG HOUSING	CONNECTEUR "MOLEX MINI-FIT" 22 CTS		

UPPER CONTROL BOX ASSEMBLY ASSEMBLAGE BOITIER HAUT

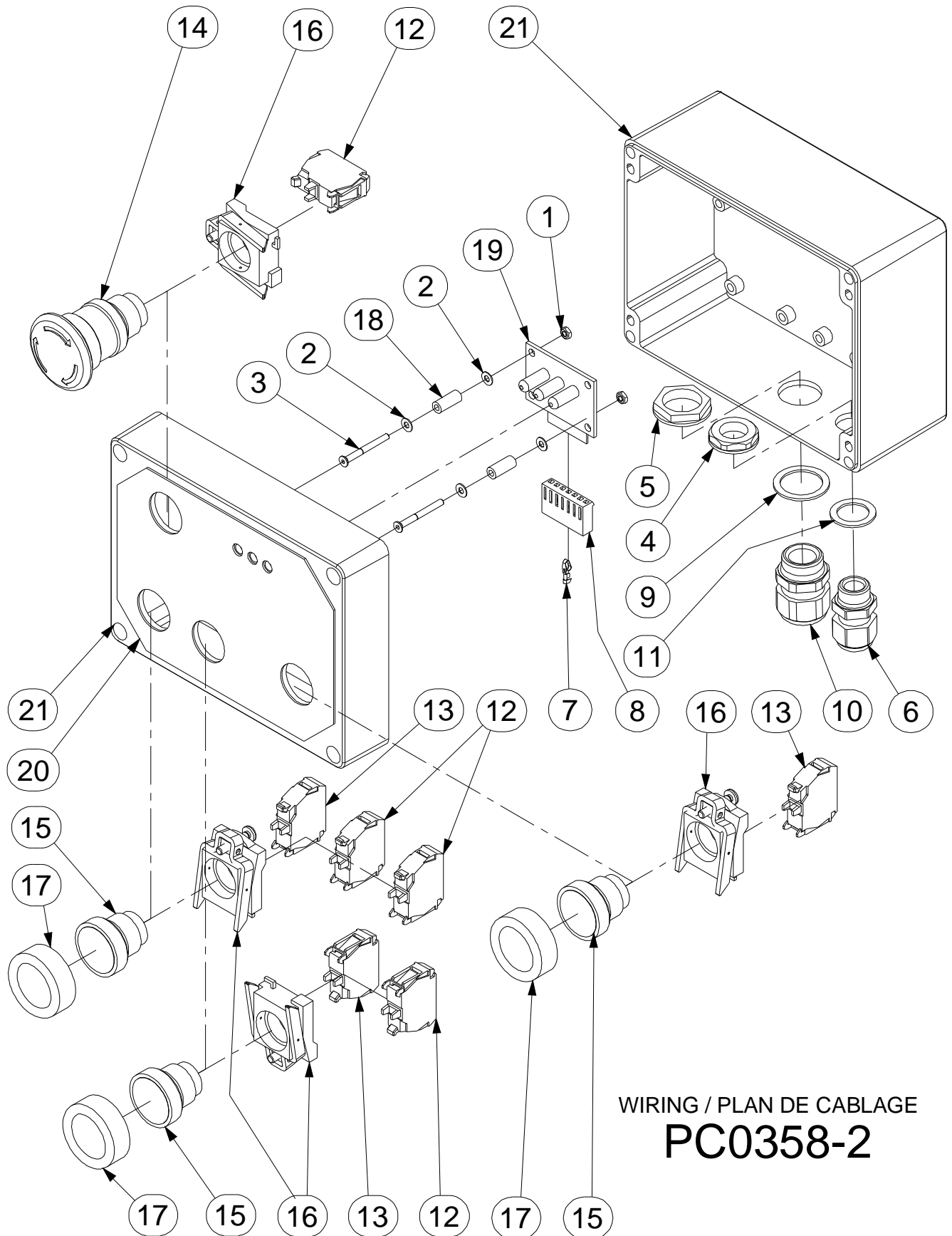

WIRING / PLAN DE CABLAGE
PC0358-2

BOARD BOX ASSEMBLY ASSEMBLAGE BOITIER CARTE

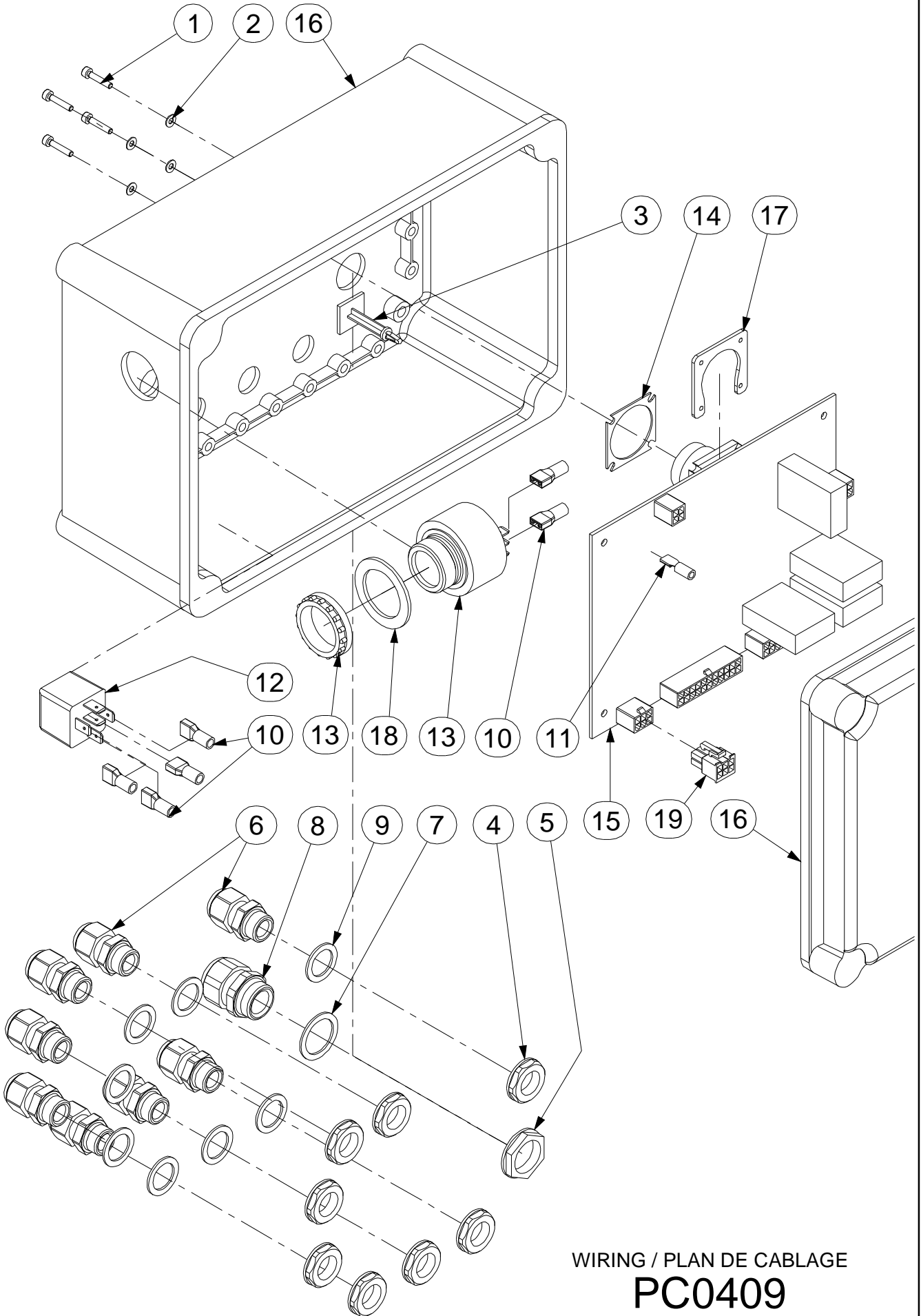

WIRING / PLAN DE CABLAGE
PC0409

SHELF BOX ASSEMBLY ASSEMBLAGE BOITIER TABLETTE

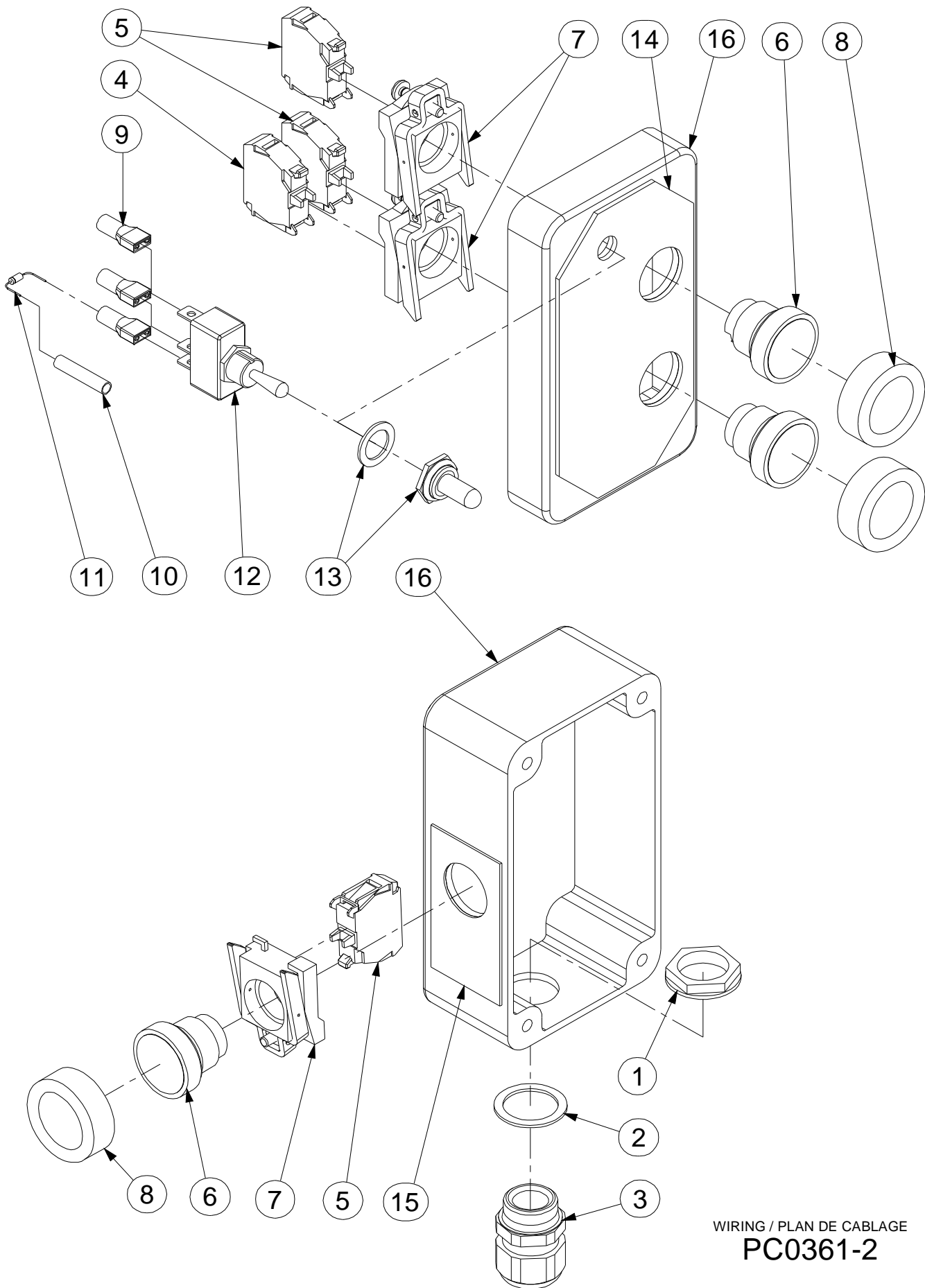

WIRING / PLAN DE CABLAGE
PC0361-2

LOWER CONTROL BOX ASSEMBLY ASSEMBLAGE BOITIER BAS

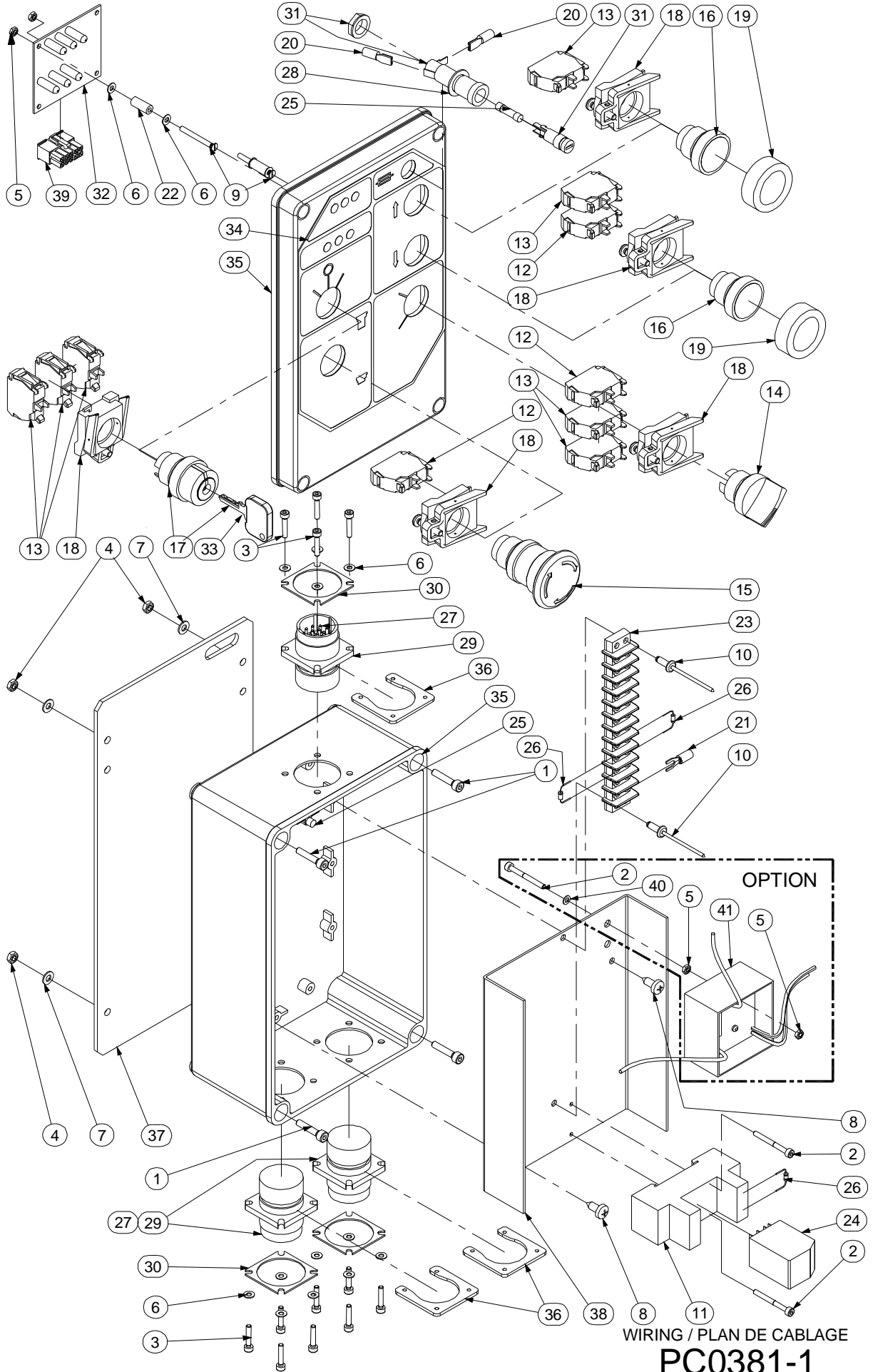

ISSUE DATE : 29/03/05

LOWER CONTROL BOX ASSEMBLY

ISSUE REL :

ASSEMBLY N° :
N° ENSEMBLE : SP0805 REV : B**ASSEMBLAGE BOITIER BAS**

1/2

DET REP	PART NUMBER REF.	SEE VIEW VOIR VUE	DESCRIPTION		R E V	QTY QTE
1	000020		M04x20 8.8 SOCKET HEAD MACH SCREW	VIS CHC M04x20 8.8 BI FT		4
2	000052		M03x30 8.8 SOCKET HEAD MACH SCREW	VIS CHC M03x30 8.8 BR FT	B	3
3	000091		M03x16 8.8 SOCKET HEAD MACH SCREW	VIS CHC M03x16 8.8 BI FT		12
4	110001		M04 GR. 8.8 LOCK NUT	ECROU FREIN M4 8.8 BI		4
5	110024		M03 GR. 8.8 LOCK NUT	ECROU FREIN M03 8.8 BI	B	4
6	120023		M03 LOCK WASHER	RONDELLE CONTACT M03 BI		16
7	120024		M04 LOCK WASHER	RONDELLE CONTACT M04 BI		4
8	130007		Ø4.8x13 LG SHEET METAL SCREW	VIS AUTOTARAUDEUSE Ø4.8-13 BI		2
9	130052		M03x30 8.8 COUNTERSUNK HEAD M. S.	VIS FHC M03x30 8.8 BI FT		2
10	180002		Ø4x10 POP RIVET	RIVET POP Ø4x10		2
11	240019		4RT RELAY BASE	EMBASE DE RELAIS 4RT		1
12	240057		NC CONTACT BLOCK	CONTACT NF		3
13	240058		NO CONTACT BLOCK	CONTACT NO		7
14	240059		2 POSITIONS SELECTOR	SELECTEUR 2 POSITIONS		1
15	240060		TURN TO RELEASE KNOB	BOUTON D'ARRET D'URGENCE 1/4 TOUR		1
16	240061		PUSH BUTTON	BOUTON POUSSOIR		2
17	240066		3 POSITIONS KEY SELECTOR	SELECTEUR A CLE 3 POSITIONS		1
18	240076		CONTACT BLOCK HOLDER	EMBASE CONTACT		5
19	240082		PUSH BUTTON CAP	CAPUCHON D'ETANCHEITE		2
20	250060		RECEPTACLE TERMINAL 4.8 - 0.25-1 mm ²	COSSE ISOLEE 4.8 mm 0.25-1 mm ²		2
21	250085		M04 FORK TERMINAL 0.5-1mm ²	COSSE FOURCHE M04 - 0.5-1mm ²		18
22	250184		Ø 3 lg 14 PLASTIC SPACER	ENTRETOISE PVC Ø 3 lg 14		2
23	250191		12 PTS TERMINAL BLOCK	BARETTE DE CONNEXION 12 PTS		1
24	260042		4RT RELAY	RELAIS 4RT		1
25	260074		5A QUICK ACTING FUSE	FUSIBLE RAPIDE 5A		2
26	260093		1A DIODE	DIODE 1A		3
27	260131		PIN CONTACT	CONTACT MALE		54
28	260134		TOGGLE SWITCH GASKET	JOINT D'INVERSEUR		1
29	260166		18 POSITIONS CHASSIS PLUG HOUSING	EMBASE CONNECTEUR 18 CONTACTS		3
30	260167		18 POSITIONS CHASSIS PLUG GASCKET	JOINT CONNECTEUR 18 CONTACTS		3
31	260224		FUSE HOLDER	PORTE FUSIBLE		1
32	290051		6 LEDS BATTERY BOARD	CARTE BATTERIE 6 LEDS		1
33	910003		KEY N°421	CLE N°421		1
34	AU1875		LOWER CONTROL BOX DECAL	AUTOCOLLANT BOITIER BAS		1
35	SD0663		DRILLED ELECTRICAL BOX	BOITIER ELECTRIQUE PERCE		1
36	ST1935		CONNECTOR PLATE	CONTRE PLAQUE CONNECTEUR		3
37	ST2743		LOWER CONTROL BOX SUPPORT SHIELD	TOLE SUPPORT BOITIER BAS		1

LOWER CONTROL BOX ASSEMBLY ASSEMBLAGE BOITIER BAS

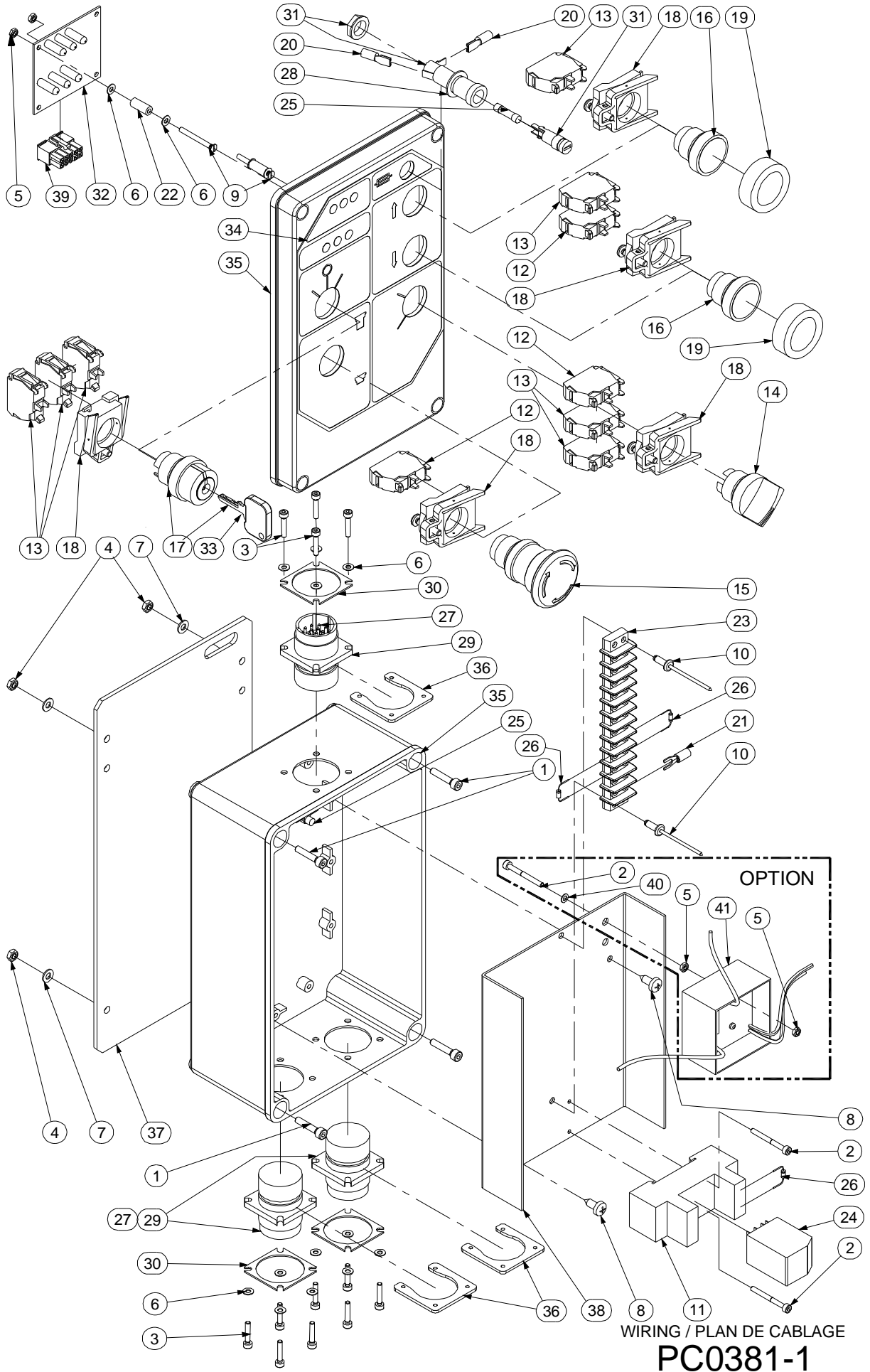

LOWER CONTROL BOX WITH HOURMETER BOITIER BAS AVEC HORAMETRE

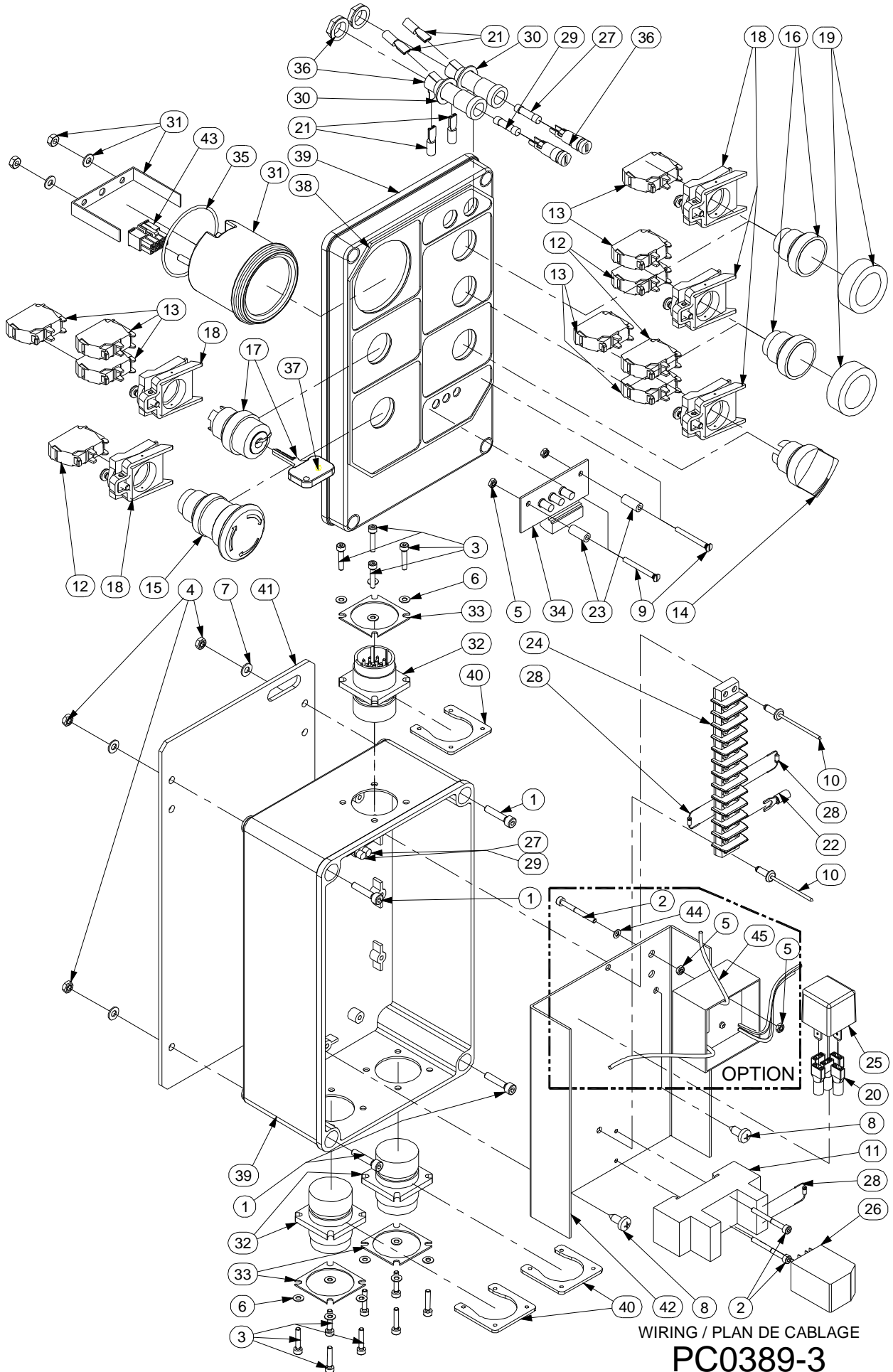

WIRING / PLAN DE CABLAGE
PC0389-3

ISSUE DATE : 29/03/05

LOWER CONTROL BOX WITH HOURMETER

ISSUE REL :

ASSEMBLY N° :
N° ENSEMBLE : SP0883 REV : A

BOITIER BAS AVEC HORAMETRE

1/2

DET REP	PART NUMBER REF.	SEE VIEW VOIR VUE	DESCRIPTION		R E V	QTY QTE
1	000020		M04x20 8.8 SOCKET HEAD MACH SCREW	VIS CHC M04x20 8.8 BI FT		4
2	000052		M03x30 8.8 SOCKET HEAD MACH SCREW	VIS CHC M03x30 8.8 BR FT	A	3
3	000091		M03x16 8.8 SOCKET HEAD MACH SCREW	VIS CHC M03x16 8.8 BI FT		12
4	110001		M04 GR. 8.8 LOCK NUT	ECROU FREIN M4 8.8 BI		4
5	110024		M03 GR. 8.8 LOCK NUT	ECROU FREIN M03 8.8 BI	A	4
6	120023		M03 LOCK WASHER	RONDELLE CONTACT M03 BI		12
7	120024		M04 LOCK WASHER	RONDELLE CONTACT M04 BI		4
8	130007		Ø4.8x13 LG SHEET METAL SCREW	VIS AUTOTARAUDEUSE Ø4.8-13 BI		2
9	130052		M03x30 8.8 COUNTERSUNK HEAD M. S.	VIS FHC M03x30 8.8 BI FT		2
10	180002		Ø4x10 POP RIVET	RIVET POP Ø4x10		2
11	240019		4RT RELAY BASE	EMBASE DE RELAIS 4RT		1
12	240057		NC CONTACT BLOCK	CONTACT NF		3
13	240058		NO CONTACT BLOCK	CONTACT NO		7
14	240059		2 POSITIONS SELECTOR	SELECTEUR 2 POSITIONS		1
15	240060		TURN TO RELEASE KNOB	BOUTON D'ARRET D'URGENCE 1/4 TOUR		1
16	240061		PUSH BUTTON	BOUTON POUSSOIR		2
17	240066		3 POSITIONS KEY SELECTOR	SELECTEUR A CLE 3 POSITIONS		1
18	240076		CONTACT BLOCK HOLDER	EMBASE CONTACT		5
19	240082		PUSH BUTTON CAP	CAPUCHON D'ETANCHEITE		2
20	250027		BLUE RECEPTACLE TER. 6.3 - 1.5-2.5mm²	COSSE FEM. 6.3 BLEUE 6.3 - 1.5-2.5mm²		5
21	250060		RECEPTACLE TERMINAL 4.8 - 0.25-1 mm²	COSSE ISOLEE 4.8 mm 0.25-1 mm²		4
22	250085		M04 FORK TERMINAL 0.5-1mm²	COSSE FOURCHE M04 - 0.5-1mm²		21
23	250184		Ø 3 lg 14 PLASTIC SPACER	ENTRETOISE PVC Ø 3 lg 14		2
24	250191		12 PTS TERMINAL BLOCK	BARETTE DE CONNEXION 12 PTS		1
25	260019		1RT 24V RELAY	RELAIS 24 V 1RT		1
26	260042		4RT RELAY	RELAIS 4RT		1
27	260074		5A QUICK ACTING FUSE	FUSIBLE RAPIDE 5A		2
28	260093		1A DIODE	DIODE 1A		3
29	260104		500mA QUICK ACTING FUSE	FUSIBLE RAPIDE 500mA		2
30	260134		TOGGLE SWITCH GASKET	JOINT D'INVERSEUR		2
31	260142		24V HOURMETER BATTERY INDICATOR	INDICATEUR DE DECHARGE HORAMETRE		1
32	260166		18 POSITIONS CHASSIS PLUG HOUSING	EMBASE CONNECTEUR 18 CONTACTS		3
33	260167		18 POSITIONS CHASSIS PLUG GASCKET	JOINT CONNECTEUR 18 CONTACTS		3
34	260174		CHARGER LEDS DISPLAY	CARTE DE VISUALISATION CHARGEUR		1
35	260209		CHARGE INDICATOR RING	JOINT INDICATEUR DE DECHARGE		1
36	260224		FUSE HOLDER	PORTE FUSIBLE		2
37	910003		KEY N°421	CLE N°421		1

SPARE PARTS
PIECES DETACHEES

SECTION 3

**MASTS ON FRAME INSTALL.
INSTALLATION MATS SUR CHASSIS.**



MASTS ON FRAME INSTALL INSTALLATION MATS SUR CHASSIS

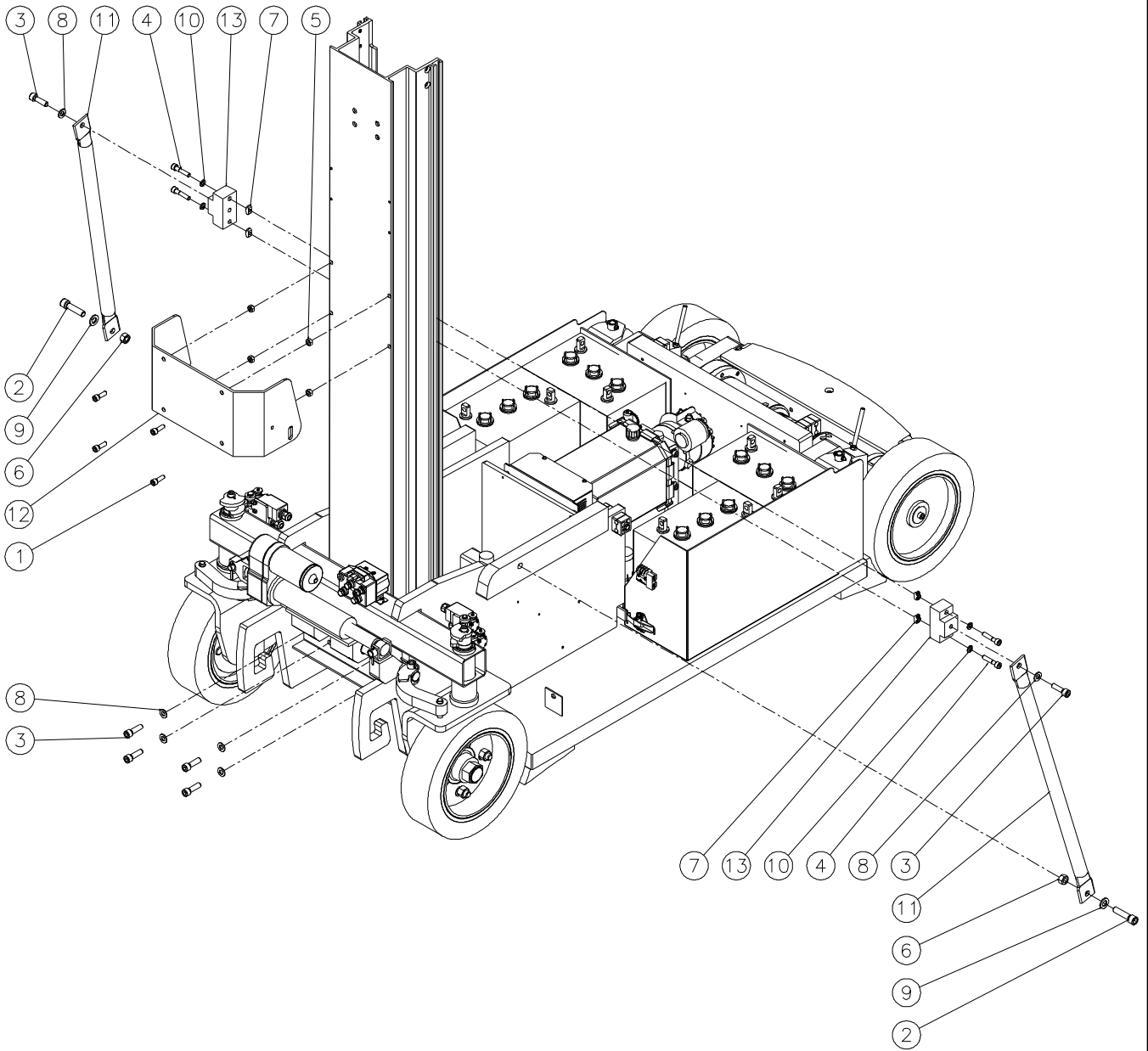

***SPARE PARTS
PIECES DETACHEES***

SECTION 4

**FRAME INSTALL.
INSTALLATION CHASSIS.**



FRAME INSTALL INSTALLATION CHASSIS

Settings for standard batteries :

- Toggle the switch 1 to "on"
- Toggle the switch 2 to "off"

Settings for gel batteries :

- Toggle the switch 1 to "off"
- Toggle the switch 2 to "on"

Les réglages pour les batteries standard sont :

- Basculer l'interrupteur 1 sur "on"
- Basculer l'interrupteur 2 sur "off"

Les réglages pour les batteries gel sont :

- Basculer l'interrupteur 1 sur "off"
- Basculer l'interrupteur 2 sur "on"

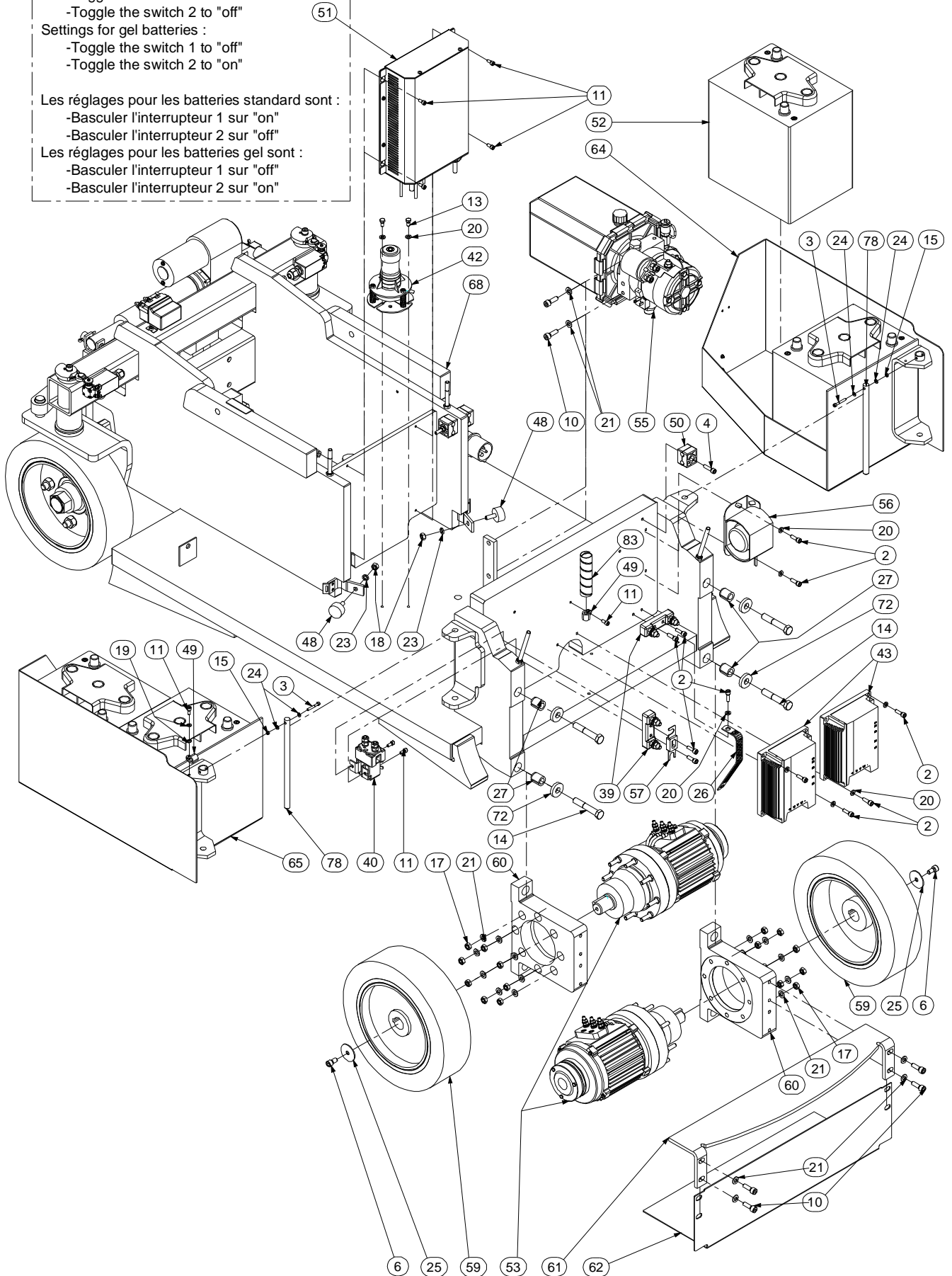

FRAME INSTALL INSTALLATION CHASSIS

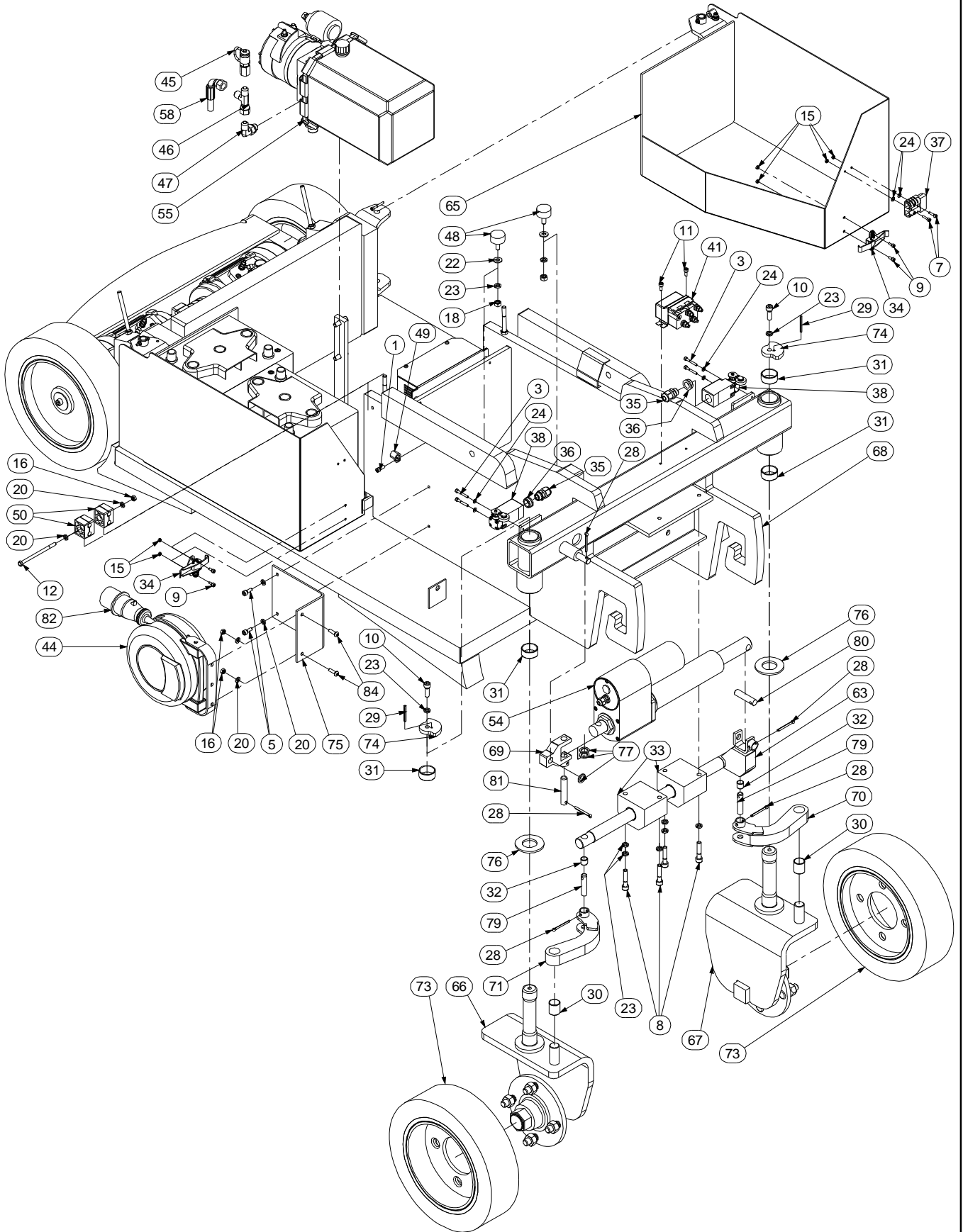

ISSUE DATE : 04/10/05

FRAME INSTALL

ISSUE REL :

ASSEMBLY N° :
N° ENSEMBLE : SP0811 REV : B**INSTALLATION CHASSIS**

1/3

DET REP	PART NUMBER REF.	SEE VIEW VOIR VUE	DESCRIPTION		R E V	QTY QTE
1	000003		M05x16 8.8 SOCKET HEAD MACH SCREW	VIS CHC M05x16 8.8 BI FT		1
2	000005		M06x20 8.8 SOCKET HEAD MACH SCREW	VIS CHC M06x20 8.8 BI FT	A	11
3	000007		M04x30 8.8 SOCKET HEAD CAPSCREW	VIS CHC M04x30 8.8 BI FP		6
4	000008		M06x25 8.8 SOCKET HEAD MACH SCREW	VIS CHC M06x25 8.8 BI FT		1
5	000015		M06x16 8.8 SOCKET HEAD MACH SCREW	VIS CHC M06x16 8.8 BI FT		2
6	000018		M08x16 8.8 SOCKET HEAD MACH SCREW	VIS CHC M08x16 8.8 BI FT		2
7	000020		M04x20 8.8 SOCKET HEAD MACH SCREW	VIS CHC M04x20 8.8 BI FT		2
8	000043		M08x40 8.8 SOCKET HEAD MACH SCREW	VIS CHC M08x40 8.8 BI FT		4
9	000050		M04x10 8.8 SOCKET HEAD MACH SCREW	VIS CHC M04x10 8.8 BI FT		4
10	000053		M08x25 8.8 SOCKET HEAD MACH SCREW	VIS CHC M08x25 8.8 BI FT		8
11	000067		M05x12 8.8 SOCKET HEAD MACH SCREW	VIS CHC M05x12 8.8 BI FT		10
12	100014		M06x80 8.8 HEX HEAD CAPSCREW	VIS H M06x80 8.8 BI FP		1
13	100027		M06x12 8.8 HEX HEAD MACHINE SCREW	VIS H M06x12 8.8 BI FT		2
14	100035		M12x70 8.8 HEX HEAD CAPSCREW	VIS H M12x70 BI FP		4
15	110001		M04 GR. 8.8 LOCK NUT	ECROU FREIN M4 8.8 BI		8
16	110003		M06 GR. 8.8 LOCK NUT	ECROU FREIN M6 8.8 BI		3
17	110004		M08 GR. 8.8 LOCK NUT	ECROU FREIN M8 8.8 BI		16
18	110016		M08 GR. 8.8 HEX NUT	ECROU H M08 8.8 BI		4
19	120002		M05 WASHER	RONDELLE M05 BI		2
20	120009		dD 06x14 LOCK WASHER	RONDELLE CONTACT dD 06x14 BI		15
21	120010		dD 08x18 LOCK WASHER	RONDELLE CONTACT dD 08x18 BI		22
22	120014		M08 WASHER	RONDELLE M08 BI		2
23	120021		HELICAL SPRING LOCK WASHER Ø8	RONDELLE GROWER Ø8 BI		12
24	120024		M04 LOCK WASHER	RONDELLE CONTACT M04 BI		10
25	120026		dD 08x40 WASHER	RONDELLE dD 08x40 BI		2
26	130022		STATIC STRAP	TRESSE DE MASSE		1
27	140018		SAFETY PIN	GOUPILLE ELASTIQUE		4
28	140019		Ø4x40 COTTER PIN	GOUPILLE FENDUE Ø4x40		5
29	140022		Ø4x40x0.8 LOCK PIN	GOUPILLE ELASTIQUE Ø4x40x0.8		2
30	150022		BUSHING Ø20 H25 DX	BAGUE Ø20 H25 DX		2
31	150025		BUSHING Ø30 H15 DU	BAGUE Ø30 H15 DU		4
32	150029		Ø12 H12 BUSHING	BAGUE Ø12 H12		2
33	150044		PILLOW BLOCK	PALIER A SEMELLE		2
34	190043		IRON LACK	GRENOUILLERE A BRAS RESSORT		2
35	210017		GLAND N°9	PRESSE ETOUPE N°9		2
36	250015		REDUCTION 13/9	REDUCTION 13/9		2
37	250038		QUICK CONNECTOR	PRISE RAPIDE		1

ISSUE DATE : 04/10/05

FRAME INSTALL

ISSUE REL :

ASSEMBLY N° :
N° ENSEMBLE : SP0811 REV : B**INSTALLATION CHASSIS**

2/3

DET REP	PART NUMBER REF.	SEE VIEW VOIR VUE	DESCRIPTION		R E V	QTY QTE
38	260030		2NC SWITCH	CAPTEUR 2NF		2
39	260077		POWER FUSE HOLDER	PORTE FUSIBLE DE PUISSANCE	A	2
40	260208		RELAY	RELAIS		1
41	260269		INVERTER RELAY	RELAIS INVERSEUR		1
42	260270		2° TILT SENSOR	DETECTEUR DE DEVERS 2°		1
43	260286		FREQUENCY CONVERTER	CONVERTISSEUR DE FREQUENCE		2
44	260287		CABLE REAL	ENROULEUR		1
45	300004		PRESSURE TEST PLUG JIC9/16 SMK	PRISE DE PRESSION JIC 9/16 SMK		1
46	300037		RUN TEE JIC 9/16 SWIVEL NUT	TE MALE JIC9/16-FEMELLE JIC9/16 TOUR.		1
47	300075		90° ELBOW MALE M14x150-MALE JIC 9/16	COUDE 90° MALE M14x150-MALE JIC 9/16		1
48	400015		ELASTIC STOP	BUTEE ELASTIQUE		4
49	400034		COLLAR	COLLIER		3
50	400037		PAIR 1/2 SHELL DOUBLE D10	PAIRE DEMI COQUILLE DOUBLE D10		3
51	510047		STANDARD CHARGER	CHARGEUR STANDARD		1
52	951011		6V 180Ah DRY BATTERIE	BATTERIE SECHE 6V 180Ah		4
52	510062		GEL BATTERY 6V 180Ah	BATTERIE GEL 6V 180Ah		4
53	510073		INDUCTION GEAR MOTOR	MOTOREDUCTEUR + FREIN ASYNCHRONE		2
54	510074		STEERING ELECTRICAL CYLINDER	VERIN ELECTRIQUE DE DIRECTION		1
55	520099	520099	COMPLETE POWER UNIT 1.25cc	CENTRALE COMPLETE 1.25cm³	A	1
56	260275		ACCOUSTIC MOTION ALARM	ALARME DE MOUVEMENT SONORE		1
57	950110		63A FUSE	FUSIBLE 63A		1
58	DF0656		Junior8/Duo HOSE (flexible) 1/4" 125cm JIC Fem 9/16 90° JIC Fem 9/16 90°-90°			1
59	DL0441		NON MARKING DRIVING WHEEL	ROUE MOTRICE NON MARQUANTE		2
60	DL0765		MOTOR FLANGE	BRIDE MOTEUR	B	2
61	ST2981		STEP	MARCHE PIED	B	1
62	ST2982		MOTORS GUARD	TOLE DE PROTECTION MOTEURS	B	1
63	DL0555		TRANSMISSION LUG	PATTE DE TRANSMISSION		1
64	DL0557		RIGHT BATTERY HOUSING	CAISSON DE BATTERIE DROIT		1
65	DL0558		LEFT BATTERY HOUSING	CAISSON DE BATTERIE GAUCHE		1
66	DL0576		RIGHT STEERING BRACKET	EQUERRE DE DIRECTION DROITE		1
67	DL0577		LEFT STEERING BRACKET	EQUERRE DE DIRECTION GAUCHE		1
68	DL0722		TDUO CE FRAME WELDMENT	CHASSIS TDUO CE		1
68	DL0766		TDUO USA FRAME WELDMENT	CHASSIS TDUO USA	B	1
69	SD0530		STEERING CYLINDER YOKE	CHAPE VERIN DE DIRECTION		1
70	SD0549		LEFT STEERING ARM	BIELETTE DE DIRECTION GAUCHE		1
71	SD0550		RIGHT STEERING ARM	BIELETTE DE DIRECTION DROITE		1
72	ST1648		MOTOR WASHER	RONDELLE MOTEUR		4

ISSUE DATE : 21/05/02

CHARGER CONNECTOR

ISSUE REL :

ASSEMBLY N° : RM0059 REV :
 N° ENSEMBLE :

PRISE CHARGEUR

1/1

DET REP	PART NUMBER REF.	SEE VIEW VOIR VUE	DESCRIPTION		REV	QTY QTE
1	7364002824		US 125 VAC MALE CONNECTOR (=260276)	PRISE US 125VAC (=260276)		1
2	260213		Yellow CONNECTOR 110VAC/16A CEI, IP44	PRISE MALE Jaune 110VAC/16A CEI, IP44		1
3	250117		UK 220 VAC MALE CONNECTOR	PRISE MALE 220VAC ROYAUME UNI		1
4	260231		BLUE CONNECTOR 220VAC/16A CEI, IP44	PRISE MALE BLEUE 220VAC/16A CEI, IP44		1
5	260214		FRENCH AND GERMAN 220V CONNECTOR	PRISE 220V FRANCAISE ET ALLEMANDE		1
6	260263		BLUE CONNECTOR 220VAC/32A CEI, IP44	PRISE MALE BLEUE 220VAC/32A CEI, IP44		1
7	260266		Yellow CONNECTOR 110VAC/32A CEI, IP44	PRISE MALE Jaune 110VAC/32A CEI, IP44		1

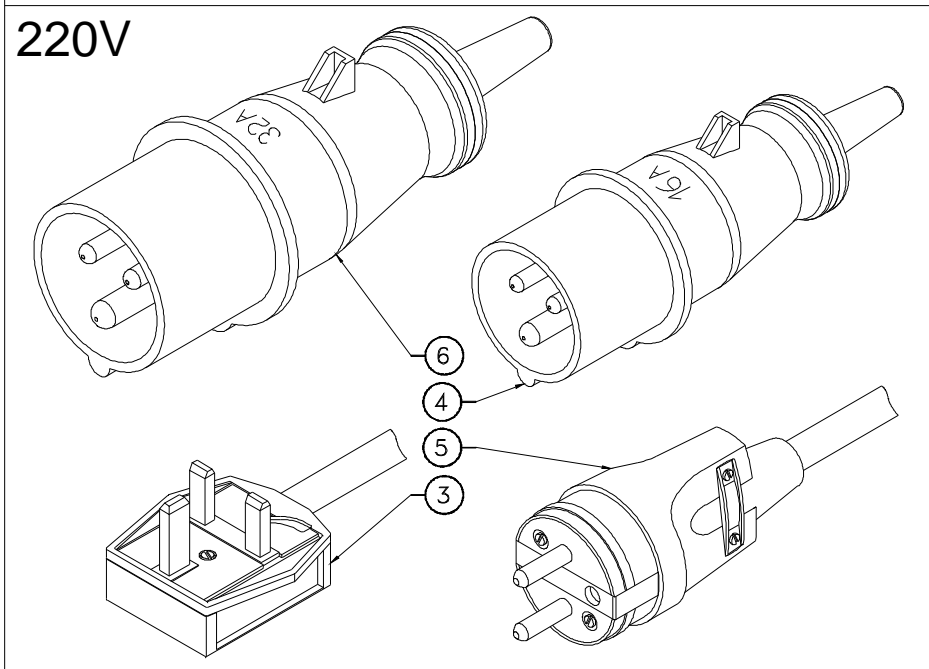
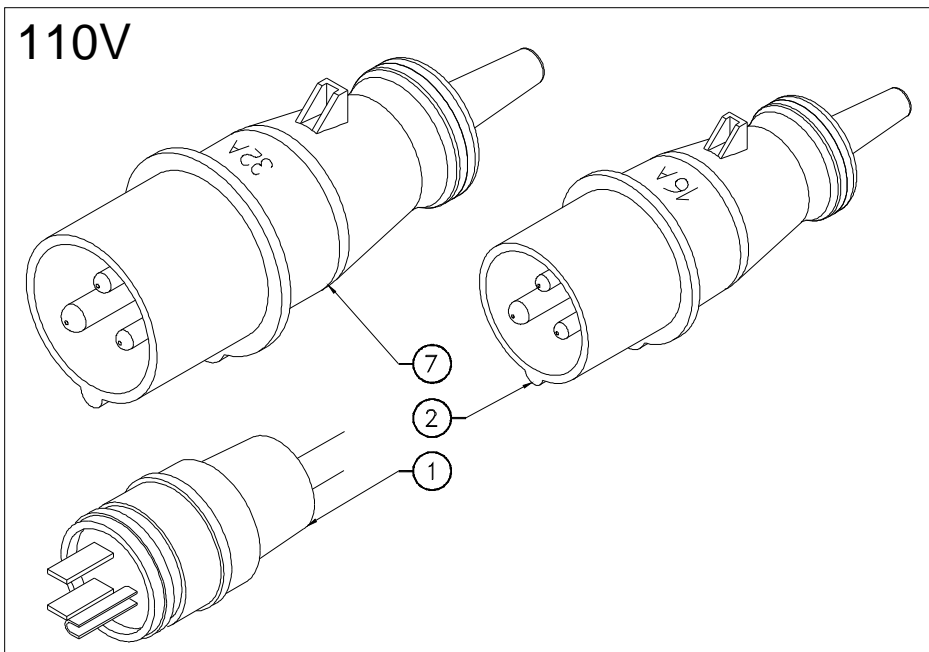

COMPLETE POWER UNIT CENTRALE COMPLETE

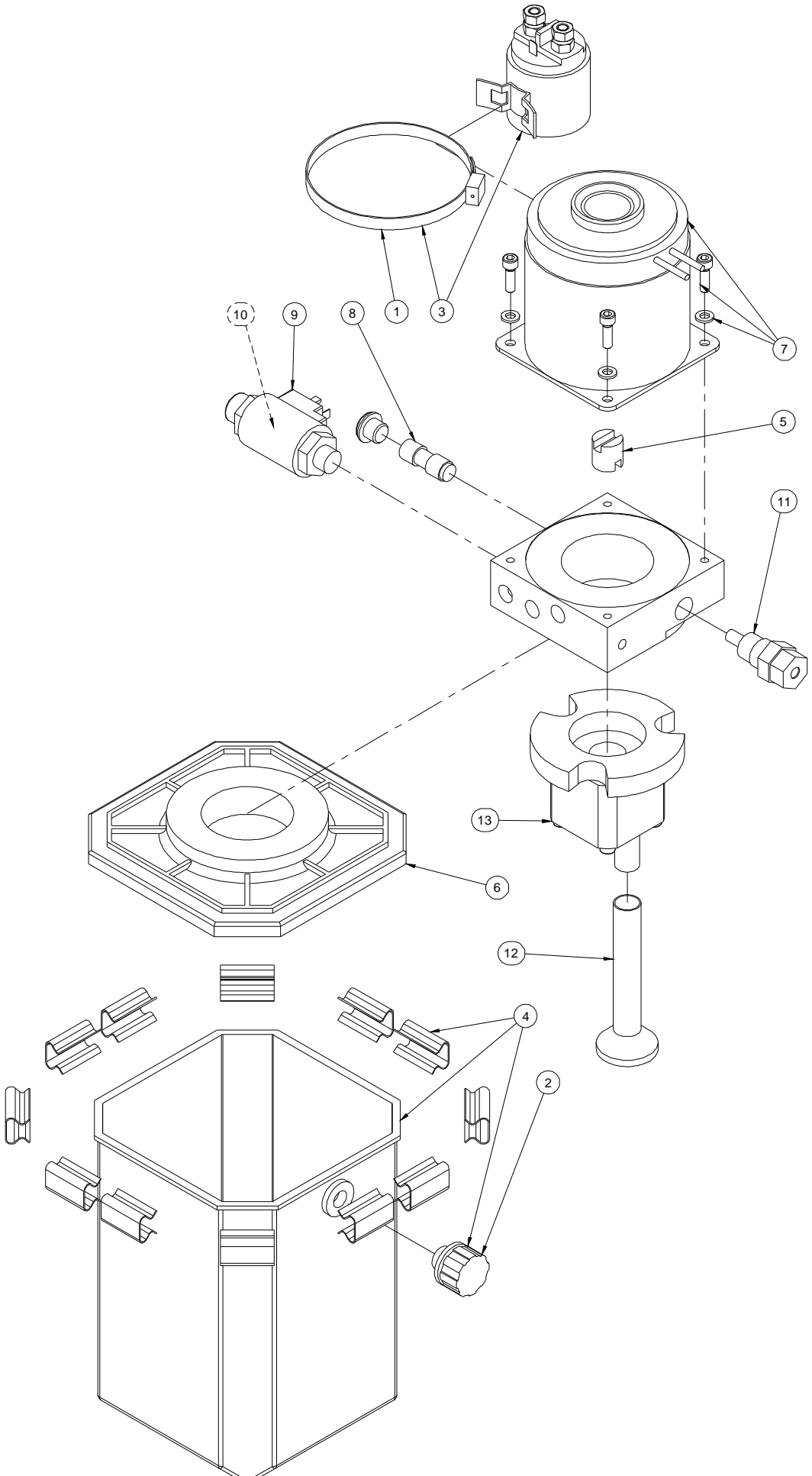

SPARE PARTS
PIECES DETACHEES

SECTION 5

MASTS INSTALL.
INSTALLATION MATS.



MASTS INSTALL INSTALLATION MATS

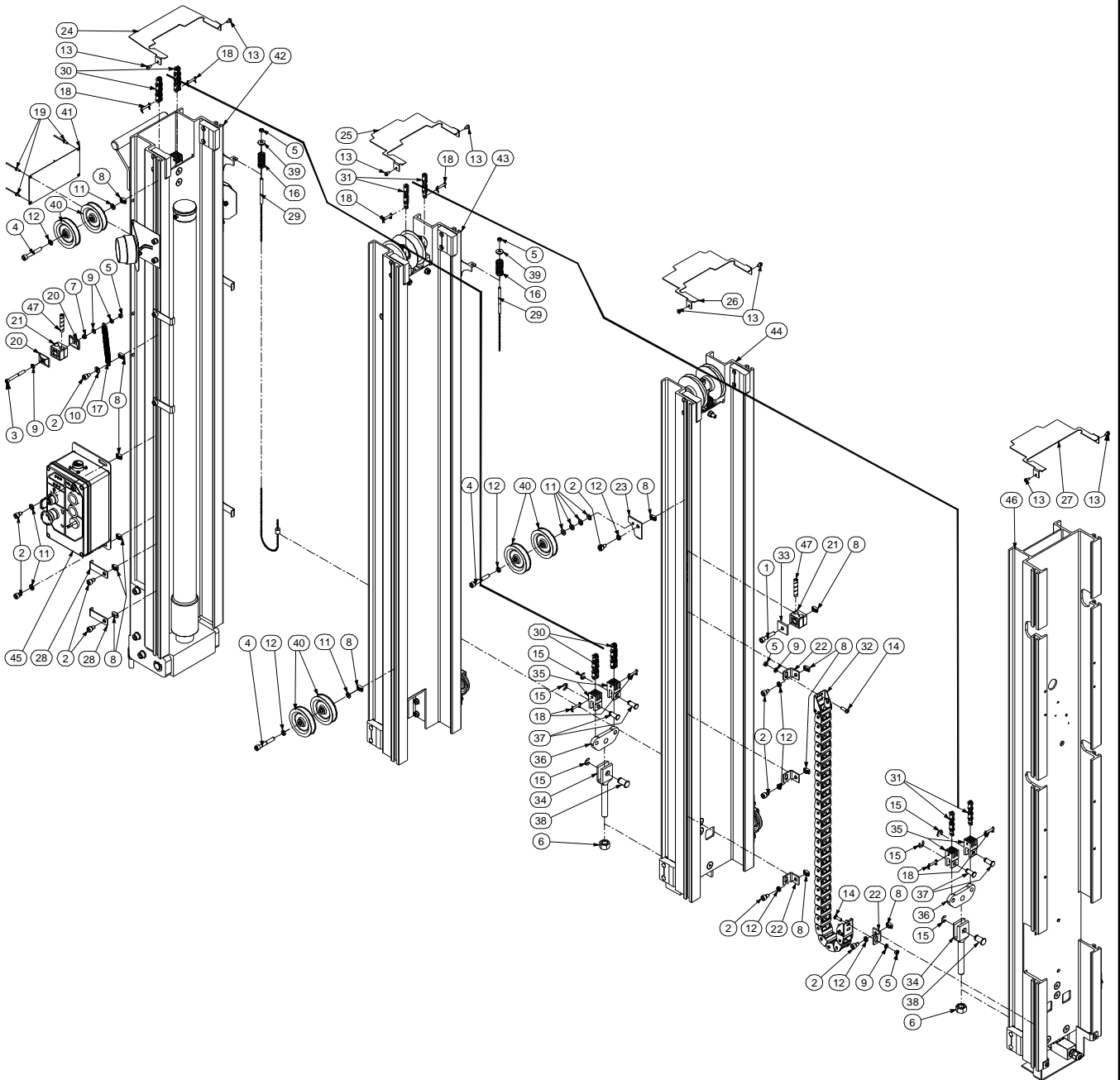

ISSUE DATE : 05/07/05

MASTS INSTALL

ISSUE REL :

ASSEMBLY N° :
N° ENSEMBLE : SP0904 REV :**INSTALLATION MATS**

1/2

DET REP	PART NUMBER REF.	SEE VIEW VOIR VUE	DESCRIPTION		R E V	QTY QTE
1	000043		M08x40 8.8 SOCKET HEAD MACH SCREW	VIS CHC M08x40 8.8 BI FT		1
2	000059		M08x12 8.8 S SOCK HEAD MACH SCREW	VIS CHC M08x12 8.8 BI FT TETE BASSE		10
3	000076		M06x60 8.8 SOCKET HEAD CAPSCREW	VIS CHC M06x60 8.8 BI FP		1
4	000078		M08x55 8.8 SOCKET HEAD CAPSCREW	VIS CHC M08x55 8.8 BI FP		3
5	110003		M06 GR. 8.8 LOCK NUT	ECROU FREIN M6 8.8 BI		5
6	110011		M16 GR. 10.9 LOCK NUT	ECROU FREIN M16 10.9 BI		2
7	110015		M06 GR. 8.8 HEX NUT	ECROU H M06 8.8 BI		1
8	110030		M08 RECTANGULAR BASE NUT	ECROU A EMBASE RECTANGULAIRE M08		13
9	120009		dD 06x14 LOCK WASHER	RONDELLE CONTACT dD 06x14 BI		5
10	120010		dD 08x18 LOCK WASHER	RONDELLE CONTACT dD 08x18 BI		1
11	120014		M08 WASHER	RONDELLE M08 BI		8
12	120021		HELICAL SPRING LOCK WASHER Ø8	RONDELLE GROWER Ø8 BI		8
13	130007		Ø4.8x13 LG SHEET METAL SCREW	VIS AUTOTARAUDEUSE Ø4.8-13 BI		8
14	130021		M06x20 8.8 ROUND HEAD MACH SCREW	VIS BOMBEE ULF M06x20 8.8 BI FT		2
15	130028		RETAINING RING Ø9	CIRCLIPS EXTERIEUR Ø9		6
16	160022		SPRING	RESSORT		2
17	160024		SPRING	RESSORT		1
18	170004		CLEVIS PIN	AXE DE CHAPE		8
19	180002		Ø4x10 POP RIVET	RIVET POP Ø4x10		4
20	400012		PAIR 1/2 SHELL PLATE	BRIDE PAIRE DEMI COQUILLE		2
21	400037		PAIR 1/2 SHELL DOUBLE D10	PAIRE DEMI COQUILLE DOUBLE D10		2
22	ST1110		PLATFORM T-BRACKET	EQUERRE PANIER		4
23	ST1120		PULLEY BRACKET	SUPPORT POULIE		1
24	ST1146		MAST TOP COVER 1	CAPOT MAT 1		1
25	ST1147		MAST TOP COVER 2 & 4	CAPOT MAT 2 & 4		1
26	ST1148		MAST TOP COVER 3 & 5	CAPOT MAT 3 & 5		1
27	ST1149		MAST TOP COVER 6	CAPOT MAT 6		1
28	ST1193		WIRE FIXATION	FIXATION CABLE		2
29	ST1627		MAST BACKUP CABLE	CABLE DE RAPPEL DE MATS		2
30	ST1630		LL10-44 CHAIN	CHAINE LL10-44		2
31	ST1632		LL10-22 CHAIN	CHAINE LL10-22		2
32	ST1634		POWER BRIDGE	CHEMIN DE CABLE		1
33	ST2529		DOUBLE CLAMP PLATE	PLAQUE COLLIER DOUBLE		1
34	US0281		CHAIN ANCHOR	CHAPE DE REGLAGE		2
35	US0282		YOKE	CHAPE DE CHAINE		4
36	US0283		SPREADER	PALONNIER DE REGLAGE		2
37	US0284		CHAIN ANCHOR PIN	AXE DE CHAPE DE CHAINE		4

MASTS INSTALL INSTALLATION MATS

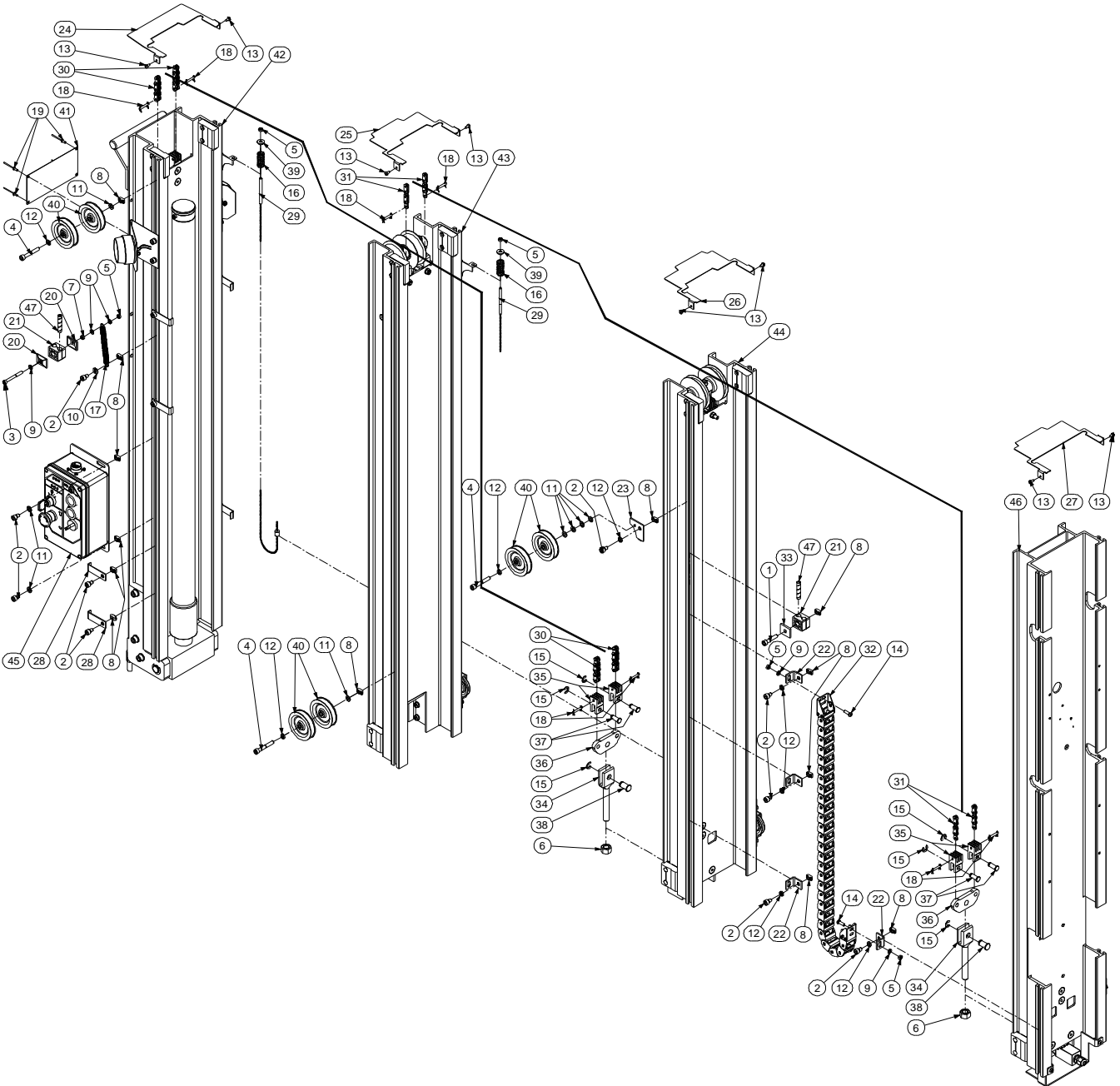

MAST 1 ASSEMBLY ASSEMBLAGE MAT 1

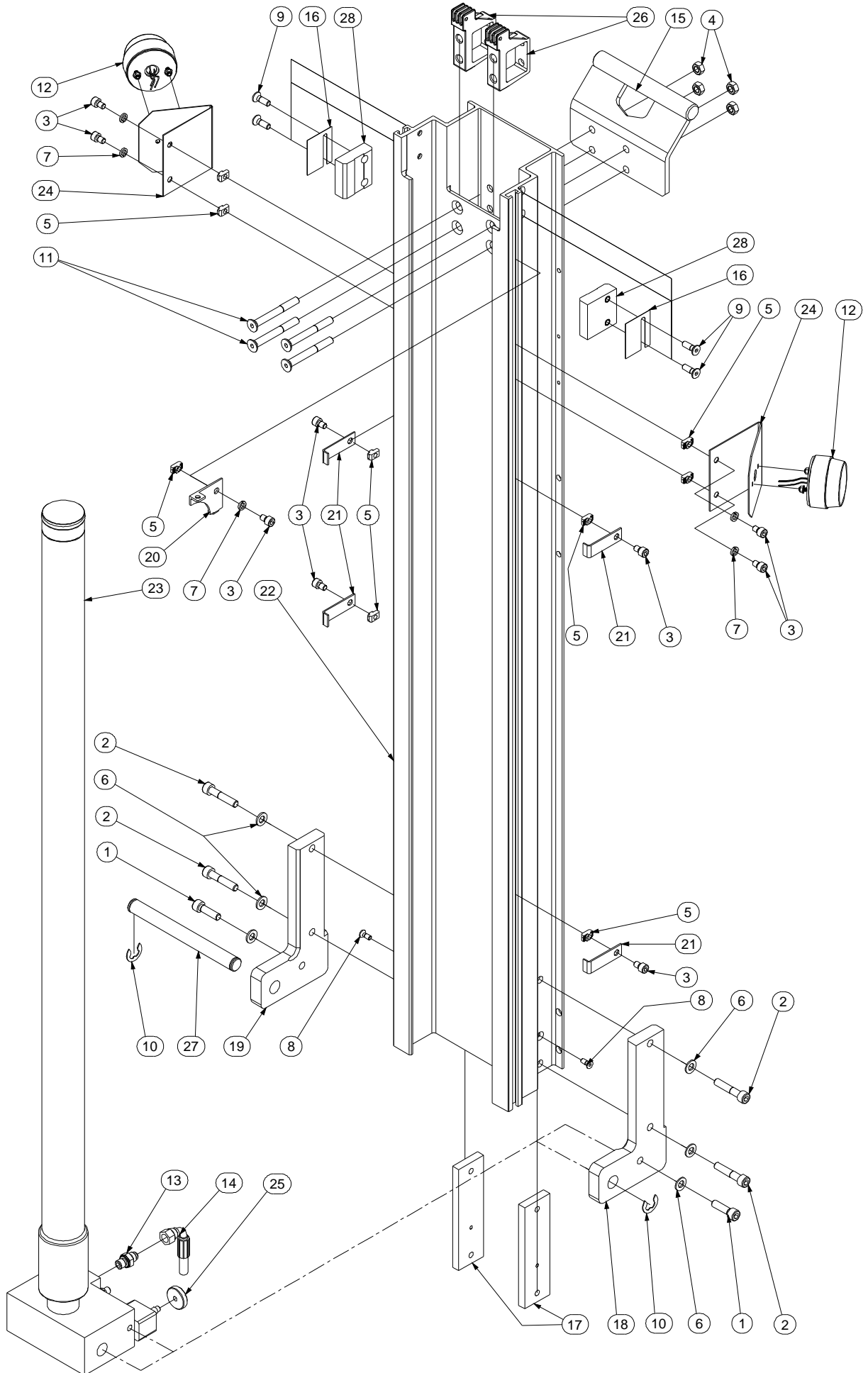

ISSUE DATE : 05/10/05

MAST 1 ASSEMBLY

ISSUE REL :

ASSEMBLY N° : SP0813 REV : A
 N° ENSEMBLE :

ASSEMBLAGE MAT 1

1/1

DET REP	PART NUMBER REF.	SEE VIEW VOIR VUE	DESCRIPTION		R E V	QTY QTE
1	000019		M10x35 8.8 SOCKET HEAD MACH SCREW	VIS CHC M10x35 8.8 BI FT		2
2	000035		M10x50 12.9 SOCKET HEAD CAPSCREW	VIS CHC M10x50 12.9 BR FT		4
3	000059		M08x12 8.8 S SOCK HEAD MACH SCREW	VIS CHC M08x12 8.8 BI FT TETE BASSE		9
4	110005		M10 GR. 8.8 LOCK NUT	ECROU FREIN M10 8.8 BI		4
5	110030		M08 RECTANGULAR BASE NUT	ECROU A EMBASE RECTANGULAIRE M08		9
6	120011		dD 10x22 LOCK WASHER	RONDELLE CONTACT dD 10x22 BI		6
7	120021		HELICAL SPRING LOCK WASHER Ø8	RONDELLE GROWER Ø8 BI		5
8	130003		M06x16 10.9 COUNTERSUNK HEAD M. S.	VIS FHC M06x16 10.9 BI FT		2
9	130025		M08x25 10.9 COUNTERSUNK HEAD M. S.	VIS FHC M08x25 10.9 BI FT		4
10	130029		RETAINING RING Ø15	CIRCLIPS EXTERIEUR Ø15		2
11	130033		M10x90 10.9 COUNTERSUNK HEAD CAPS	VIS FHC M10x90 10.9 BI FP		4
12	260229		FLASHING LIGHT	FEU A ECLAT		2
13	300025		FITTING MALE BSPP1/4-MALE JIC9/16	RACCORD MALE BSPP1/4-MALE JIC9/16		1
14	DF0656		Junior8/Duo HOSE (flexible) 1/4" 125cm JIC Fem 9/16 90° JIC Fem 9/16 90°-90°		A	1
15	DL0440		LIFTING BRACKET	ANNEAU D'ELINGUAGE		1
16	ST1109		SHIM (4 sizes : see Service Manual)	CALE (4 épaisseurs: voir Manuel de Service)		2
17	ST1113		BASE PLATE CYLINDER	BRIDE DE VERIN		2
18	ST1114		LEFT CYLINDER BRACKET	PATTE GAUCHE DE VERIN		1
19	ST1115		RIGHT CYLINDER BRACKET	PATTE DROITE DE VERIN		1
20	ST1119		STEEL WIRE BRACKET	EQUERRE CABLE		1
21	ST1193		WIRE FIXATION	FIXATION CABLE		4
22	ST1625		MAST 1	MAT 1		1
23	ST1628	ST1628	MAST CYLINDER	VERIN DE MAT		1
24	ST2147		FLASHING LIGHT BRACKET	SUPPORT LAMPE A ECLAT		2
25	US0277		CYLINDER EMERGENCY BUTTON	BOUTON D'URGENCE VERIN		1
26	US0278		CHAIN ANCHOR	CHAPE DE CHAINE		2
27	US0289		MAST CYLINDER PIN	AXE VERIN		1
28	US0321		SLIDE BLOCK (4 sizes: see Service Manual)	PATIN (4 épaisseurs: voir Manuel de Service)		2

MAST CYLINDER VERIN DE MAT

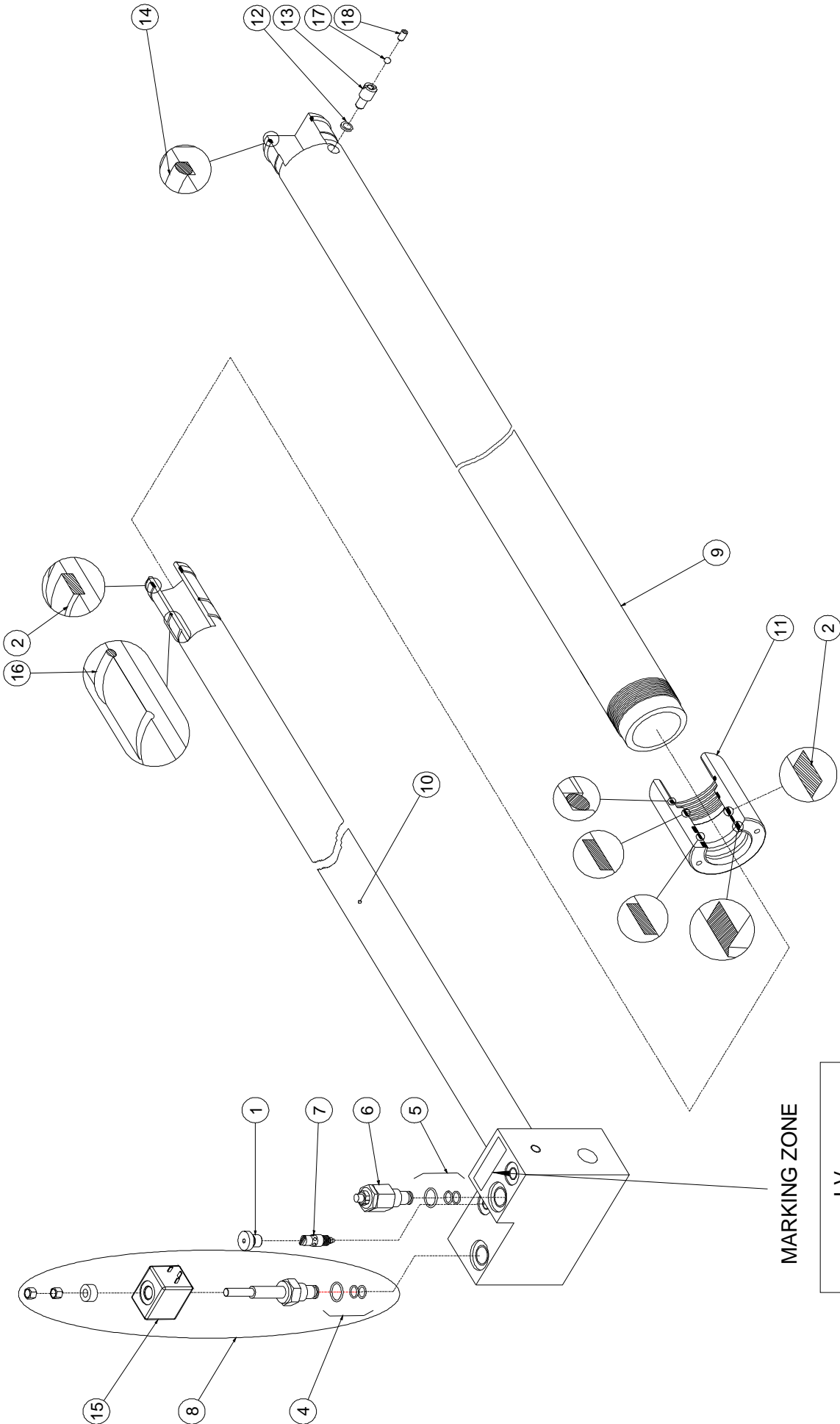

MAST 2 ASSEMBLY ASSEMBLAGE MAT 2

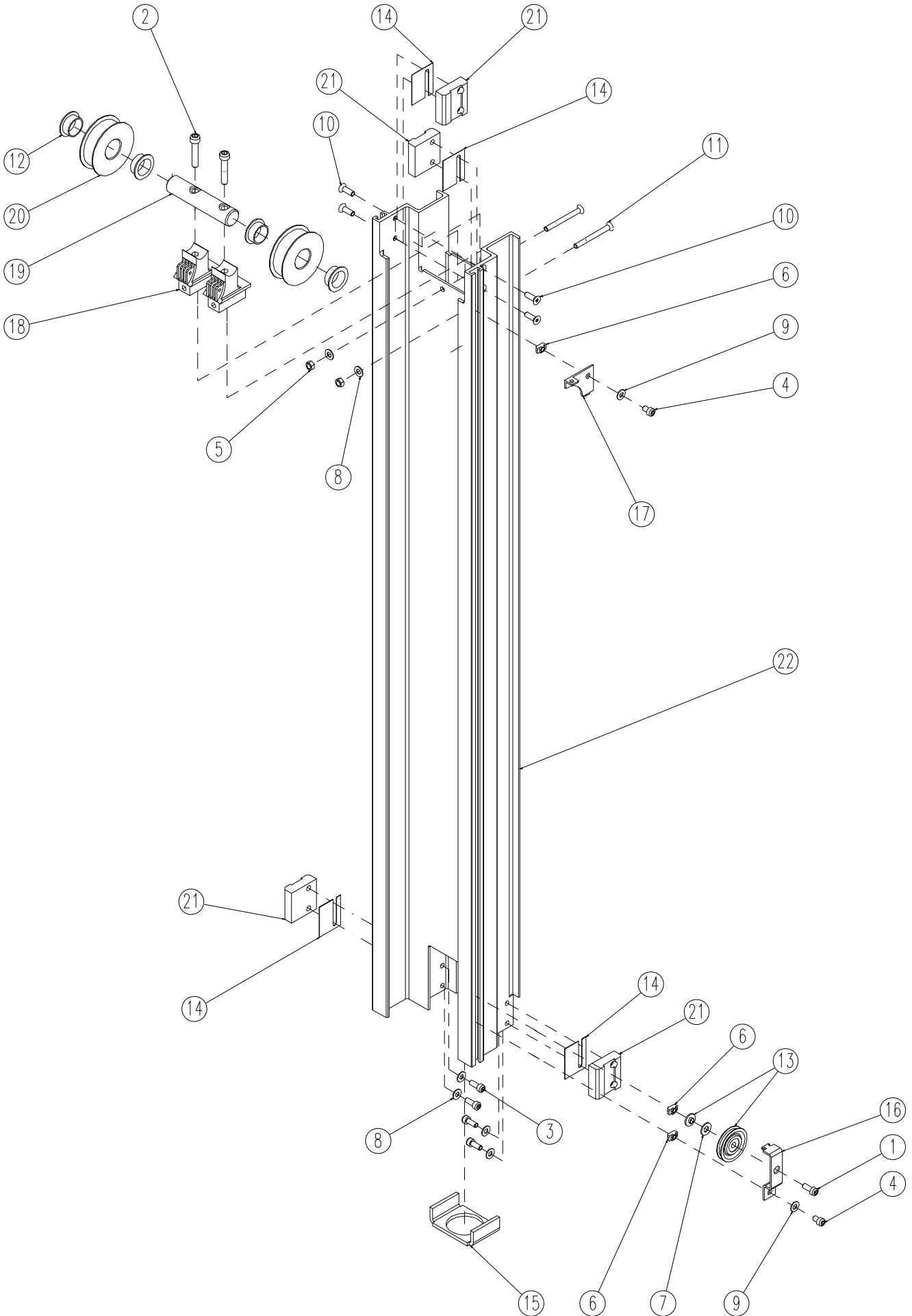

ISSUE DATE : 11/02/03

MAST 2 ASSEMBLY

ISSUE REL :

ASSEMBLAGE MAT 2

ASSY NO : SP0386 REV : A

1/1

DET NO.	PART NUMBER	SEE VIEW	DESCRIPTION		REV	QTY REQ.
1	000006		M08x20 8.8 SOCKET HEAD MACH SCREW	VIS CHC M08x20 8.8 BI FT		1
2	000035		M10x50 12.9 SOCKET HEAD CAPSCREW	VIS CHC M10x50 12.9 BR FT		2
3	000058		M08x20 8.8 S SOCK. HEAD MACH SCREW	VIS CHC M08x20 8.8 BI FT TETE BASSE		4
4	000059		M08x12 8.8 S SOCK HEAD MACH SCREW	VIS CHC M08x12 8.8 BI FT TETE BASSE		2
5	110004		M08 GR. 8.8 LOCK NUT	ECROU FREIN M8 8.8 BI		2
6	110030		M08 RECTANGULAR BASE NUT	ECROU A EMBASE RECTANGULAIRE M08		3
7	120011		dD 10x22 LOCK WASHER	RONDELLE CONTACT dD 10x22 BI		1
8	120014		M08 WASHER	RONDELLE M08 BI		6
9	120021		HELICAL SPRING LOCK WASHER Ø8	RONDELLE GROWER Ø8 BI		2
10	130025		M08x25 10.9 COUNTERSUNK HEAD M. S.	VIS FHC M08x25 10.9 BI FT		4
11	130031		M08x80 10.9 COUNTERSUNK HEAD CAPS.	VIS FHC M08x80 10.9 BI FP		2
12	150007		FLANGE BUSHING Ø30 H16 DU	BAGUE EPAULEE Ø30 H16 DU		4
13	150028		BACKUP PULLEY	POULIE DE RAPPEL		1
14	ST1109		SHIM (4 sizes : see Service Manual)	CALE (4 épaisseurs: voir Manuel de Service)		4
15	ST1111		CYLINDER BASE PLATE	BUTEE DE VERIN		1
16	ST1118		BACKUP PULLEY SUPPORT	SUPPORT POULIE DE RAPPEL		1
17	ST1119		STEEL WIRE BRACKET	EQUERRE CABLE		1
18	US0279		PULLEY SUPPORT A	SUPPORT POULIE A		2
19	US0286		PULLEY PIN	AXE DE POULIE		1
20	US0473		PULLEY Ø80x23.5	POULIE Ø80x23.5	A	2
21	US0321		SLIDE BLOCK (4 sizes: see Service Manual)	PATIN (4 épaisseurs: voir Manuel de Service)		4
22	ST1629		MAST 2	MAT 2		1

MAST 3 ASSEMBLY ASSEMBLAGE MAT 3

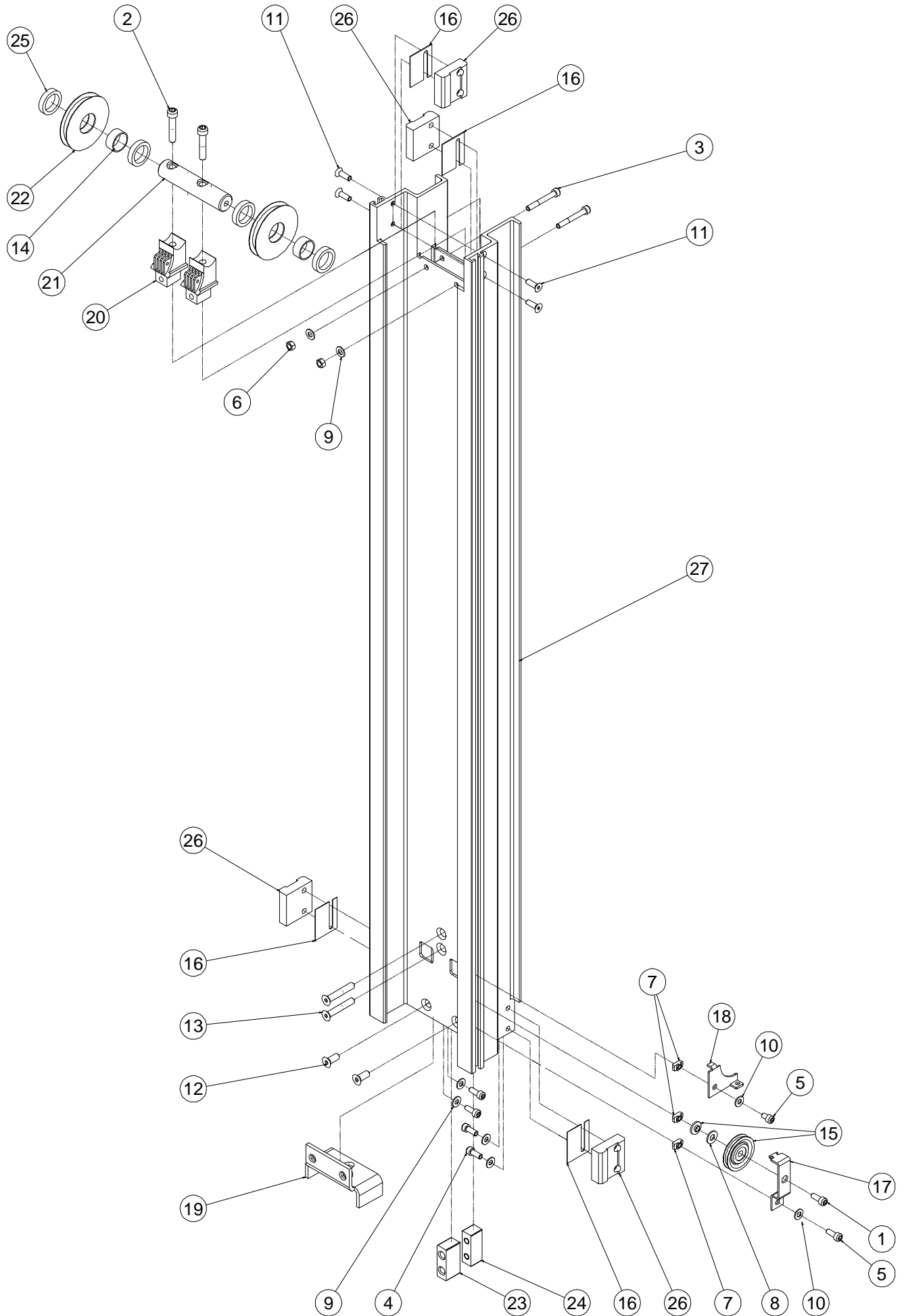

ISSUE DATE : 17/03/03

MAST (3/TJ6/Tduo or 5/TJ8) ASSEMBLY

ISSUE REL :

ASSY NO : SP0387 REV : A

ASSEMBLAGE MAT (3/TJ6/Tduo ou 5/TJ8)

1/1

DET NO.	PART NUMBER	SEE VIEW	DESCRIPTION		REV	QTY REQ.
1	000006		M08x20 8.8 SOCKET HEAD MACH SCREW	VIS CHC M08x20 8.8 BI FT		1
2	000035		M10x50 12.9 SOCKET HEAD CAPSCREW	VIS CHC M10x50 12.9 BR FT		2
3	000057		M08x60 8.8 S SOCKET HEAD CAPSCREW	VIS CHC M08x60 8.8 BI FT TETE BASSE		2
4	000058		M08x20 8.8 S SOCK. HEAD MACH SCREW	VIS CHC M08x20 8.8 BI FT TETE BASSE		4
5	000059		M08x12 8.8 S SOCK HEAD MACH SCREW	VIS CHC M08x12 8.8 BI FT TETE BASSE		2
6	110004		M08 GR. 8.8 LOCK NUT	ECROU FREIN M8 8.8 BI		2
7	110030		M08 RECTANGULAR BASE NUT	ECROU A EMBASE RECTANGULAIRE M08		3
8	120011		dD 10x22 LOCK WASHER	RONDELLE CONTACT dD 10x22 BI		1
9	120014		M08 WASHER	RONDELLE M08 BI		6
10	120021		HELICAL SPRING LOCK WASHER Ø8	RONDELLE GROWER Ø8 BI		2
11	130025		M08x25 10.9 COUNTERSUNK HEAD M. S.	VIS FHC M08x25 10.9 BI FT		4
12	130030		M010x25 10.9 COUNTERSUNK HEAD M. S.	VIS FHC M10x25 10.9 BI FT		2
13	130032		M010x60 10.9 COUNTERSUNK HEAD M. S.	VIS FHC M10x60 10.9 BI FT		2
14	150025		BUSHING Ø30 H15 DU	BAGUE Ø30 H15 DU		2
15	150028		BACKUP PULLEY	POULIE DE RAPPEL		1
16	ST1109		SHIM (4 sizes : see Service Manual)	CALE (4 épaisseurs: voir Manuel de Service)		4
17	ST1118		BACKUP PULLEY SUPPORT	SUPPORT POULIE DE RAPPEL		1
18	ST1119		STEEL WIRE BRACKET	EQUERRE CABLE		1
19	ST1125		SPREADER BRACKET	EQUERRE PALONNIER		1
20	US0280		PULLEY SUPPORT B	SUPPORT POULIE B		2
21	US0286		PULLEY PIN	AXE DE POULIE		1
22	US0474		PULLEY Ø83x10	POULIE Ø83x10	A	2
23	US0296		SAFETY SPACER	ENTRETOISE DE SECURITE		1
24	US0297		SAFETY BLOCK	SECURITE PALONNIER		1
25	US0298		PULLEY SPACER	ENTRETOISE POULIES		4
26	US0321		SLIDE BLOCK (4 sizes: see Service Manual)	PATIN (4 épaisseurs: voir Manuel de Service)		4
27	ST1631		MAST 3	MAT 3		1

MAST 4 ASSEMBLY ASSEMBLAGE MAT 4

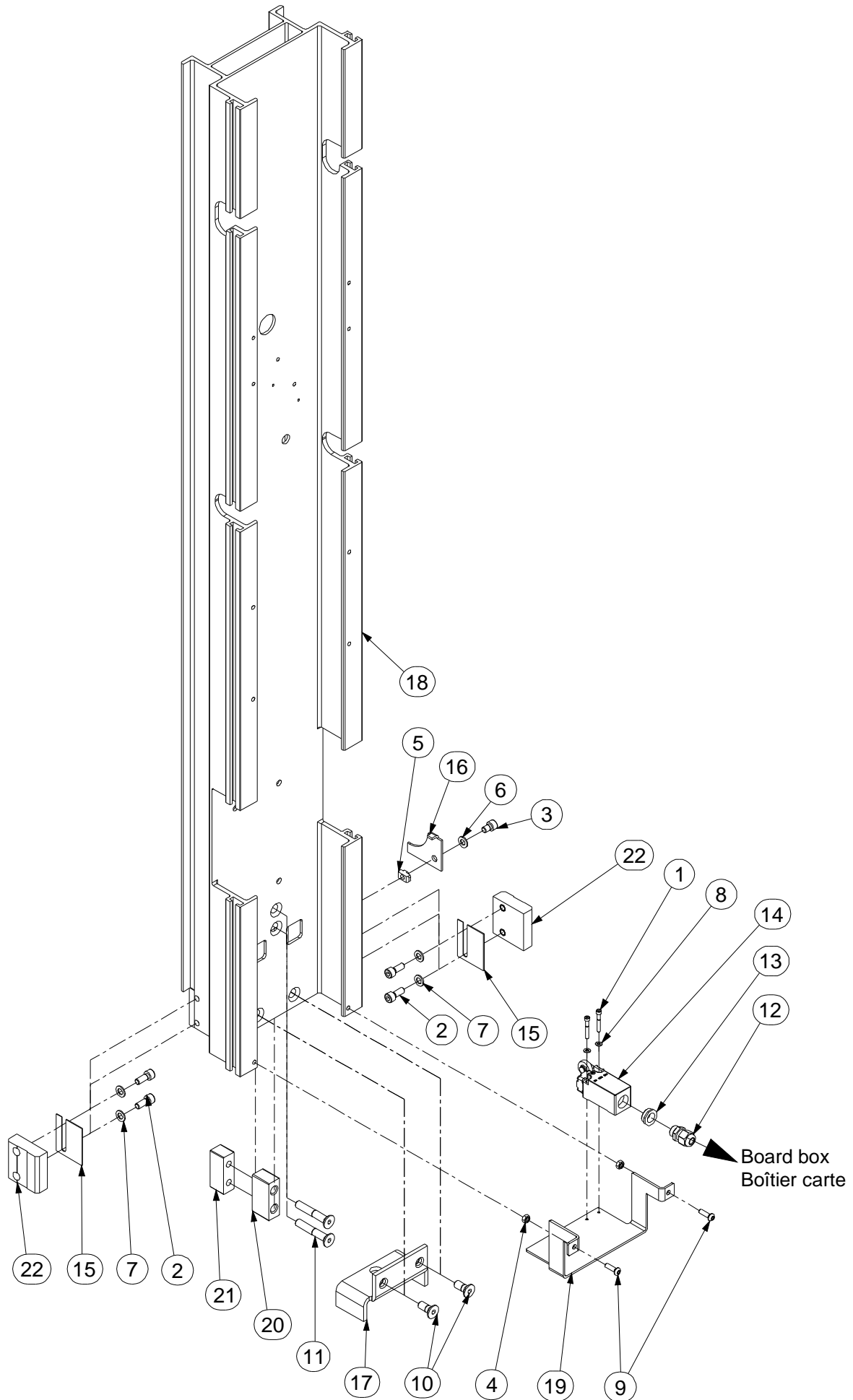

ISSUE DATE : 13/09/05

MAST 4 ASSEMBLY

ISSUE REL :

ASSEMBLY N° : SP0900 REV :
N° ENSEMBLE :**ASSEMBLAGE MAT 4**

1/1

DET REP	PART NUMBER REF.	SEE VIEW VOIR VUE	DESCRIPTION		R E V	QTY QTE
1	000007		M04x30 8.8 SOCKET HEAD CAPSCREW	VIS CHC M04x30 8.8 BI FP		2
2	000058		M08x20 8.8 S SOCK. HEAD MACH SCREW	VIS CHC M08x20 8.8 BI FT TETE BASSE		4
3	000059		M08x12 8.8 S SOCK HEAD MACH SCREW	VIS CHC M08x12 8.8 BI FT TETE BASSE		1
4	110003		M06 GR. 8.8 LOCK NUT	ECROU FREIN M6 8.8 BI		2
5	110030		M08 RECTANGULAR BASE NUT	ECROU A EMBASE RECTANGULAIRE M08		1
6	120021		HELICAL SPRING LOCK WASHER Ø8	RONDELLE GROWER Ø8 BI		1
7	120014		M08 WASHER	RONDELLE M08 BI		4
8	120024		M04 LOCK WASHER	RONDELLE CONTACT M04 BI		2
9	130021		M06x20 8.8 ROUND HEAD MACH SCREW	VIS BOMBEE ULF M06x20 8.8 BI FT		2
10	130030		M010x25 10.9 COUNTERSUNK HEAD M. S.	VIS FHC M10x25 10.9 BI FT		2
11	130032		M010x60 10.9 COUNTERSUNK HEAD M. S.	VIS FHC M10x60 10.9 BI FT		2
12	210017		GLAND N°9	PRESSE ETOUPE N°9		1
13	250015		REDUCTION 13/9	REDUCTION 13/9		1
14	260030		2NC SWITCH	CAPTEUR 2NF		1
15	ST1109		SHIM (4 sizes : see Service Manual)	CALE (4 épaisseurs: voir Manuel de Service)		2
16	ST1119		STEEL WIRE BRACKET	EQUERRE CABLE		1
17	ST1125		SPREADER BRACKET	EQUERRE PALONNIER		1
18	ST1633		MAST 4	MAT 4		1
19	ST2521		SWITCH HOLDER	SUPPORT CAPTEUR		1
20	US0296		SAFETY SPACER	ENTRETOISE DE SECURITE		1
21	US0297		SAFETY BLOCK	SECURITE PALONNIER		1
22	US0321		SLIDE BLOCK (4 sizes: see Service Manual)	PATIN (4 épaisseurs: voir Manuel de Service)		2

SPARE PARTS ***PIECES DETACHEES***

SECTION 6

**PLATFORM AND TABLE INSTALL.
INSTALLATION PANIER ET TABLETTE.**



PLATFORM AND TABLE INSTALL INSTALLATION PANIER ET TABLETTE

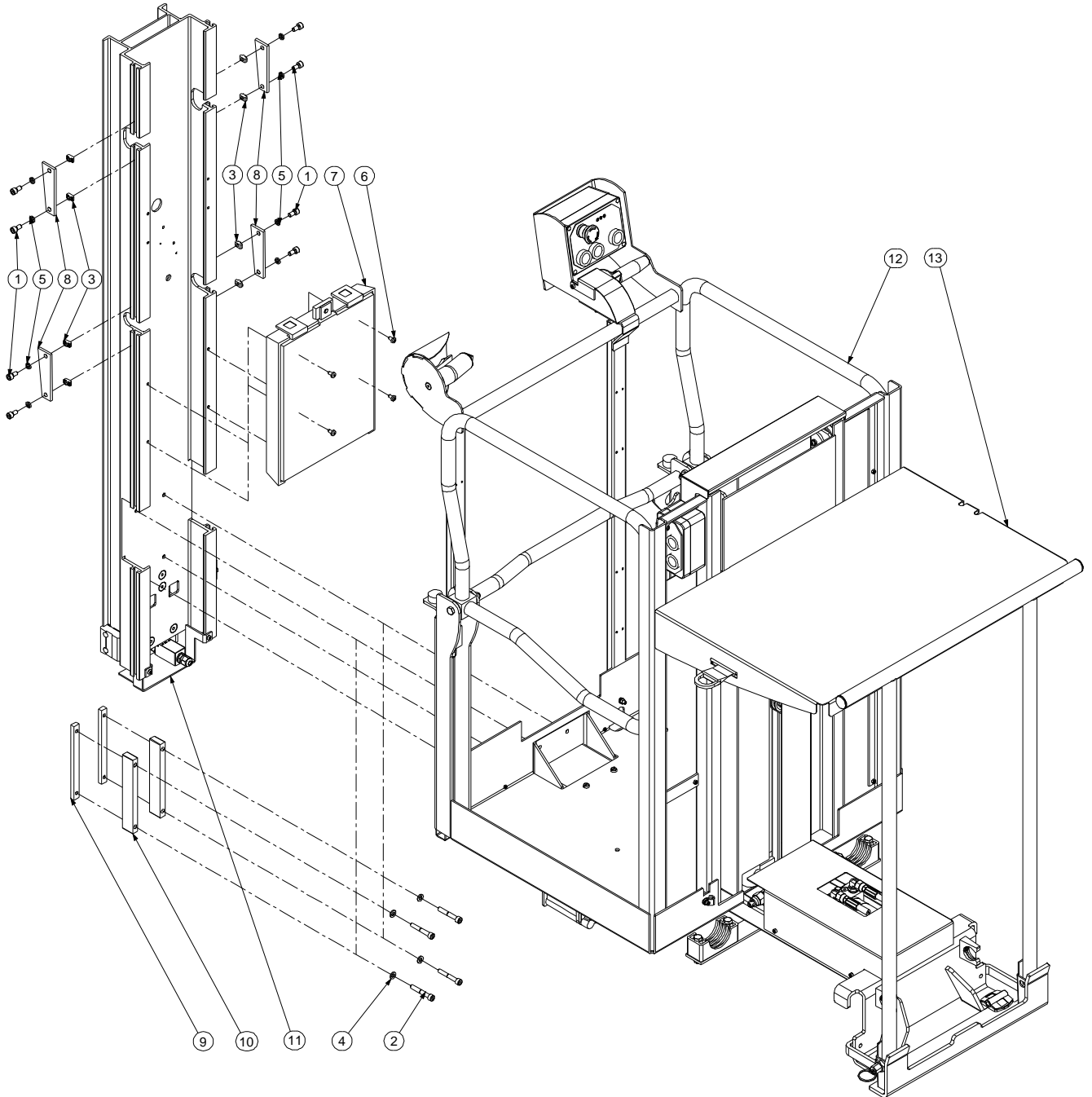

PLATFORM ASSEMBLY ASSEMBLAGE PLATE-FORME

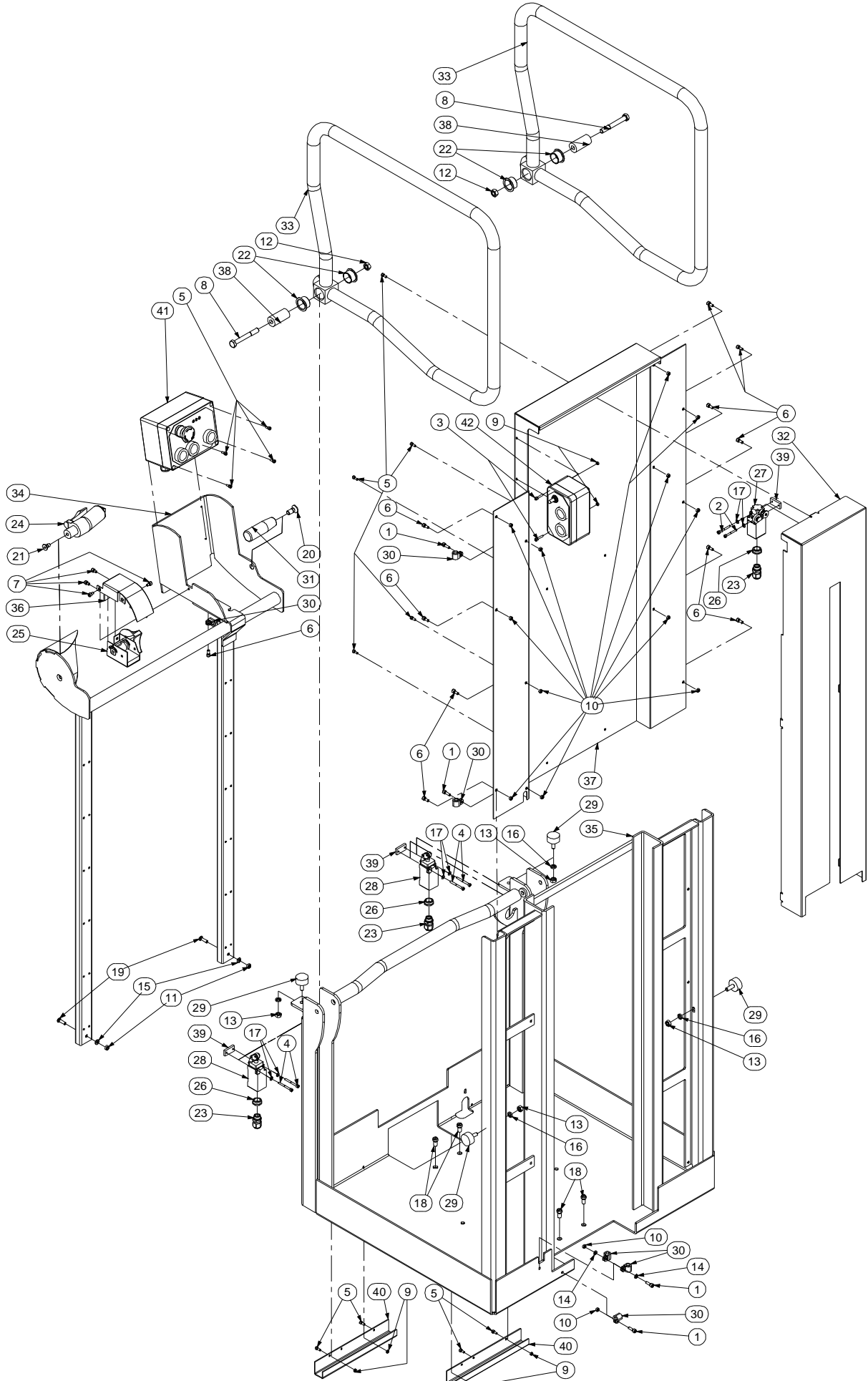

ISSUE DATE : 19/09/05

PLATFORM ASSEMBLY

ISSUE REL :

ASSEMBLY N° :
N° ENSEMBLE : SP0901 REV :**ASSEMBLAGE PLATE-FORME**

1/2

DET REP	PART NUMBER REF.	SEE VIEW VOIR VUE	DESCRIPTION		R E V	QTY QTE
1	000003		M05x16 8.8 SOCKET HEAD MACH SCREW	VIS CHC M05x16 8.8 BI FT		4
2	000004		M04x35 8.8 SOCK. HEAD MACH. SCREW	VIS CHC M04x35 8.8 BI FT		2
3	000020		M04x20 8.8 SOCKET HEAD MACH SCREW	VIS CHC M04x20 8.8 BI FT		2
4	000032		M04x40 8.8 SOCKET HEAD CAPSCREW	VIS CHC M04x40 8.8 ZI FP		4
5	000050		M04x10 8.8 SOCKET HEAD MACH SCREW	VIS CHC M04x10 8.8 BI FT		13
6	000067		M05x12 8.8 SOCKET HEAD MACH SCREW	VIS CHC M05x12 8.8 BI FT		11
7	000089		M05x08 8.8 SOCKET HEAD MACH SCREW	VIS CHC M05x08 8.8 BI FT		4
8	100091		M10x80 8.8 HEX HEAD CAPSCREW	VIS H M10x80 8.8 BI FP		2
9	110001		M04 GR. 8.8 LOCK NUT	ECROU FREIN M4 8.8 BI		6
10	110002		M05 GR. 8.8 LOCK NUT	ECROU FREIN M5 8.8 BI		14
11	110003		M06 GR. 8.8 LOCK NUT	ECROU FREIN M6 8.8 BI		2
12	110005		M10 GR. 8.8 LOCK NUT	ECROU FREIN M10 8.8 BI		2
13	110016		M08 GR. 8.8 HEX NUT	ECROU H M08 8.8 BI		4
14	120002		M05 WASHER	RONDELLE M05 BI		2
15	120009		dD 06x14 LOCK WASHER	RONDELLE CONTACT dD 06x14 BI		2
16	120021		HELICAL SPRING LOCK WASHER Ø8	RONDELLE GROWER Ø8 BI		4
17	120024		M04 LOCK WASHER	RONDELLE CONTACT M04 BI		6
18	130013		M08x16 CROSS PAN HEAD CAPSCREW	VIS BOMBEE FENDUE M08x16 BI FT		4
19	130021		M06x20 8.8 ROUND HEAD MACH SCREW	VIS BOMBEE ULF M06x20 8.8 BI FT		2
20	130030		M010x25 10.9 COUNTERSUNK HEAD M. S.	VIS FHC M10x25 10.9 BI FT		1
21	130053		M08x16 8.8 COUNTERSUNK HEAD M. S.	VIS FHC M08x16 8.8 BI FT		1
22	150039		FLANGE BUSHING Ø25 H16.5 DU	BAGUE EPAULEE Ø25 H16.5 DU		4
23	210017		GLAND N°9	PRESSE ETOUPE N°9		3
24	240086		STEERING HANDLE	POIGNEE DE DIRECTION		1
25	240091		CONTROL HANDLE	POIGNEE DE COMMANDE		1
26	250015		REDUCTION 13/9	REDUCTION 13/9		3
27	260016		SWITCH	CAPTEUR		1
28	260182		SWITCH	CAPTEUR		2
29	400015		ELASTIC STOP	BUTEE ELASTIQUE		4
30	400034		COLLAR	COLLIER		6
31	400089		PLASTIC HANDLE	POIGNEE PLASTIQUE		1
32	DL0750		OUTSIDE COVER	CAPOT EXTERNE		1
33	DL0751		GATE	PORTILLON		2
34	DL0752		CONTROL HANDLE	GUIDON DE COMMANDE		1
35	DL0753		PLATFORM GUARDRAIL	ARMATURE PLATE-FORME		1
36	DL0754		DRIVE HANDLE COVER	CAPOT POIGNEE TRANSLATION		1
37	DL0755		INSIDE COVER	CAPOT INTERIEUR		1

PLATFORM ASSEMBLY ASSEMBLAGE PLATE-FORME

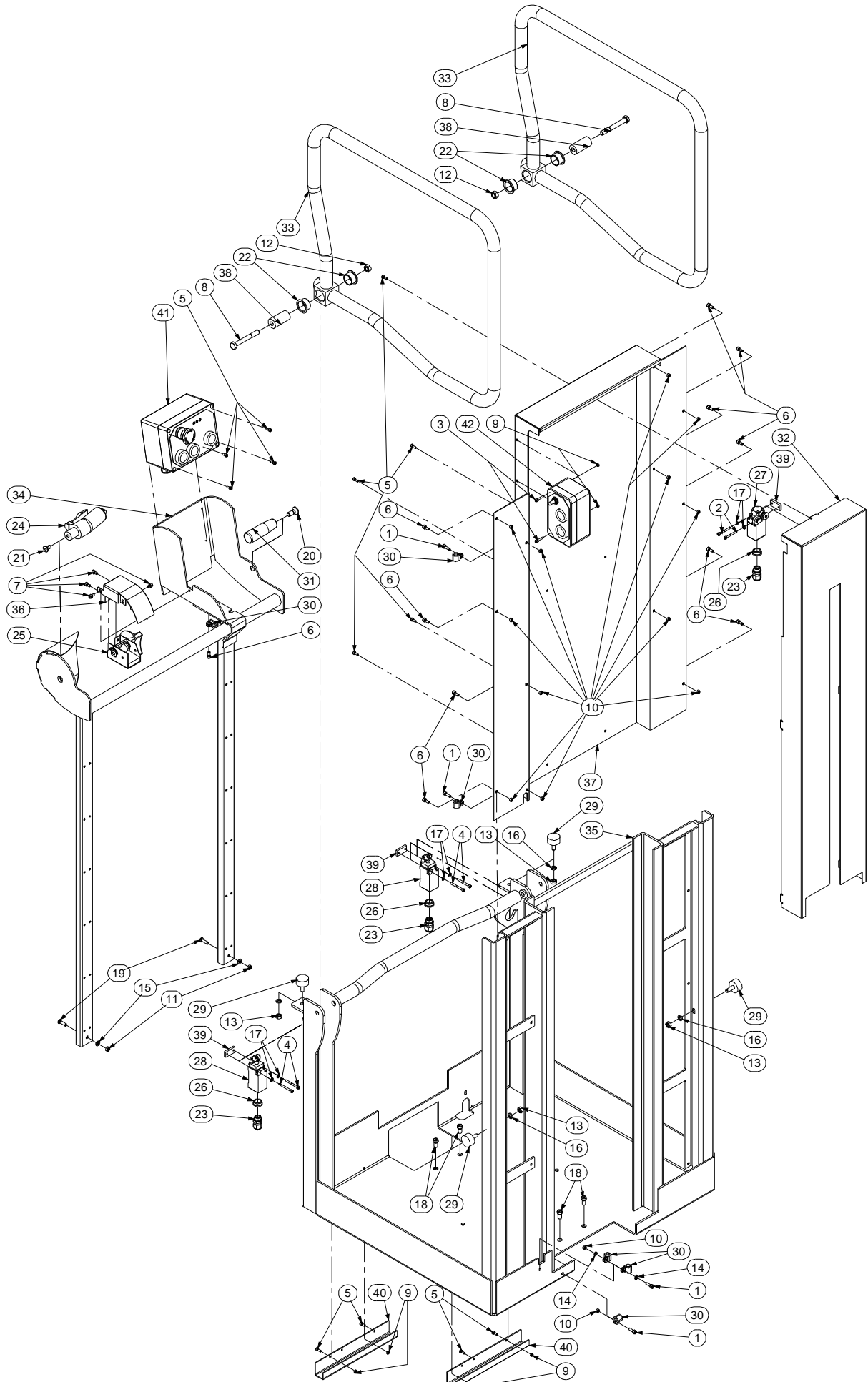

SELF ASSEMBLY ASSEMBLAGE TABLETTE

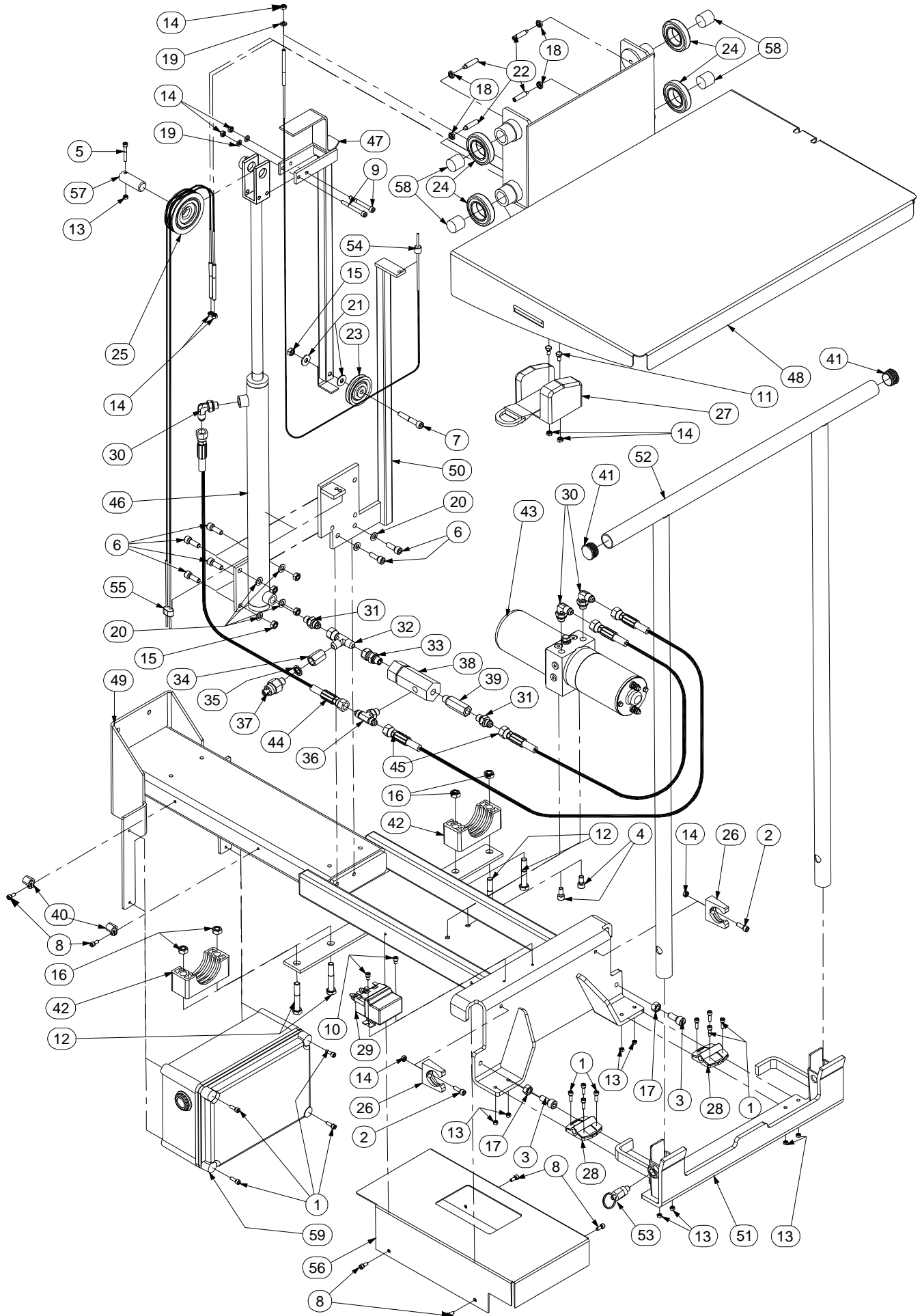

ISSUE DATE : 21/09/05

SHELF ASSEMBLY

ISSUE REL :

ASSEMBLY N° :
N° ENSEMBLE : SP0902 REV :**ASSEMBLAGE TABLETTE**

1/2

DET REP	PART NUMBER REF.	SEE VIEW VOIR VUE	DESCRIPTION		R E V	QTY QTE
1	000003		M05x16 8.8 SOCKET HEAD MACH SCREW	VIS CHC M05x16 8.8 BI FT		12
2	000005		M06x20 8.8 SOCKET HEAD MACH SCREW	VIS CHC M06x20 8.8 BI FT		2
3	000013		M10x25 8.8 SOCKET HEAD MACH SCREW	VIS CHC M10x25 8.8 BI FT		2
4	000018		M08x16 8.8 SOCKET HEAD MACH SCREW	VIS CHC M08x16 8.8 BI FT		2
5	000030		M05x35 8.8 SOCKET HEAD CAPSCREW	VIS CHC M05x35 8.8 ZI FP		1
6	000053		M08x25 8.8 SOCKET HEAD MACH SCREW	VIS CHC M08x25 8.8 BI FT		6
7	000063		M08x45 8.8 S SOCKET HEAD CAPSCREW	VIS CHC M08x45 8.8 BI FT TETE BASSE		1
8	000067		M05x12 8.8 SOCKET HEAD MACH SCREW	VIS CHC M05x12 8.8 BI FT		6
9	000073		M06x55 8.8 SOCKET HEAD CAPSCREW	VIS CHC M06x55 8.8 BI FP		2
10	000089		M05x08 8.8 SOCKET HEAD MACH SCREW	VIS CHC M05x08 8.8 BI FT		2
11	100027		M06x12 8.8 HEX HEAD MACHINE SCREW	VIS H M06x12 8.8 BI FT		2
12	100039		M10x60 8.8 HEX HEAD MACHINE SCREW	VIS H M10x60 8.8 BI FT		4
13	110002		M05 GR. 8.8 LOCK NUT	ECROU FREIN M5 8.8 BI		9
14	110003		M06 GR. 8.8 LOCK NUT	ECROU FREIN M6 8.8 BI		9
15	110004		M08 GR. 8.8 LOCK NUT	ECROU FREIN M8 8.8 BI		5
16	110005		M10 GR. 8.8 LOCK NUT	ECROU FREIN M10 8.8 BI		4
17	110008		M10 GR. 8.8 HEX NUT	ECROU H M10 8.8 BI		2
18	110022		M08 GR. 8.8 FLAT HEX NUT	ECROU Hm M08 8.8 ZI		4
19	120009		dD 06x14 LOCK WASHER	RONDELLE CONTACT dD 06x14 BI		3
20	120010		dD 08x18 LOCK WASHER	RONDELLE CONTACT dD 08x18 BI		6
21	120014		M08 WASHER	RONDELLE M08 BI		2
22	130056		M08x35 HC SCREW	VIS HC M08x35 BI		4
23	150028		BACKUP PULLEY	POULIE DE RAPPEL		1
24	150056		6007 2RS BEARING	ROULEMENT 6007 2RS		4
25	150057		DOUBLE PULLEY FOR ELEVATION	POULIE DOUBLE DE LEVAGE		1
26	190028		Ø28 CLIP	CLIP Ø28		2
27	190070		STRAP ROLLER	SANGLE A ENROULEUR		1
28	190071		POSITIONNING HINGE	CHARNIERE INVERSEE		2
29	260269		INVERTER RELAY	RELAIS INVERSEUR		1
30	300001		90° ELBOW MALE BSPP 1/4-MALE JIC 9/16	COUDE 90° Male BSPP 1/4 -Male JIC 9/16		3
31	300025		FITTING MALE BSPP1/4-MALE JIC9/16	RACCORD MALE BSPP1/4-MALE JIC9/16		2
32	300037		RUN TEE JIC 9/16 SWIVEL NUT	TE MALE JIC9/16-FEMELLE JIC9/16 TOUR.		1
33	300073		FITTING MALE BSPP 1/4-FEMALE JIC 9/16	RACC. MALE BSPP 1/4 -FEM. JIC 9/16		1
34	300099		PRESGAUGE UNION FEM BSPT1/4-JIC9/16	UNION MANO FEM BSPT 1/4 - JIC 9/16		1
35	300108		BUSHING BS	BAGUE BS		1
36	300166		RUN TEE JIC 9/16 - CENTRAL BSPP 1/4	TE MALE JIC9/16 - BSPP 1/4 CENTRAL		1
37	310050		PRESSURE SWITCH 10-20 BARS	PRESSOSTAT 10-20 BARS		1

SPARE PARTS
PIECES DETACHEES

SECTION 7

DECALS INSTALL.
INSTALLATION AUTOCOLLANTS.



DECALS INSTALL INSTALLATION AUTOCOLLANTS

TOUCAN Duo		INSTRUCTIONS /CONSIGNES	LOAD/CHARGE	EMERGENCY /SECOURS
Belgium/Belgique	NL	AU1765	AU1766	AU1022
	F	AU1734	AU1735	AU0932
Czechoslovakia/ Tchecoslovaquie	CZ	AU1944	AU1945	AU1946
		PA0997		
Dutch/Hollande	NL	AU1765	AU1766	AU1022
		PA0913		
Finland/Finlande	FIN	AU1798	AU1799	AU1019
		PA0926		
France	F	AU1734	AU1735	AU0932
		PA0899		
Germany/Allemagne Ausria/Autriche	D	AU1751	AU1752	AU1017
	A	PA0906		
Hungary/Hongrie	H	AU1974	AU1975	AU1976
		PA1013		
Italy/Italie	I	AU1759	AU1760	AU1016
		PA0910		
Norway/Norvège	N	AU1784	AU1785	AU1783
		PA0919		
Poland/Pologne	PL	AU1795	AU1796	AU1794
		PA0922		
Portuguese/Portugal	P	AU1951	AU1952	AU1953
		PA1000		
Slovakia/ slovaquie	SL	AU1938	AU1939	AU1940
		PA0994		
Spain/Espagne	E	AU1778	AU1777	AU1024
		PA0915		
Sweden/Suède	S	AU1780	AU1781	AU1030
		PA0916		
United Kingdom Royaume uni	GB	AU1745	AU1746	AU0923
		PA0905		

PAxxxx = COMPLETE KIT / JEU COMPLET

MANUFACTURER'S NAME PLATE
PLAQUE CONSTRUCTEUR
AU1837

DECALS INSTALL INSTALLATION AUTOCOLLANTS

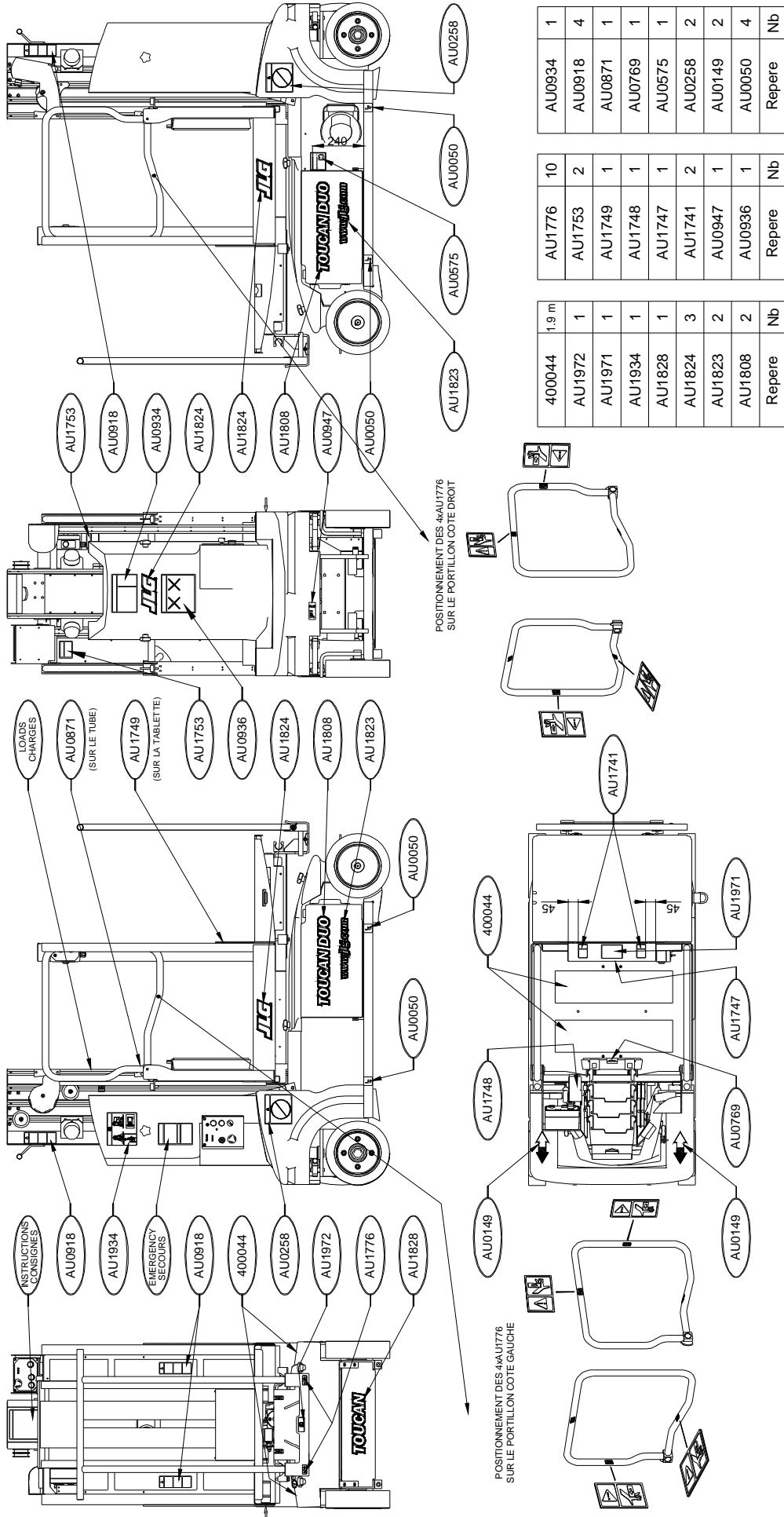

AU0934	1
AU0918	4
AU0871	1
AU0769	1
AU0575	1
AU0258	2
AU0149	2
AU0050	4
Repere	Nb

AU1776	10
AU1753	2
AU1749	1
AU1748	1
AU1747	1
AU1741	2
AU0947	1
AU0936	1
Repere	Nb

400044	1,9 m
AU1972	1
AU1971	1
AU1934	1
AU1828	1
AU1824	3
AU1823	2
AU1808	2
Repere	Nb

POSITIONNEMENT DES *AU1776
SUR LE PORTILLON COTE DROIT

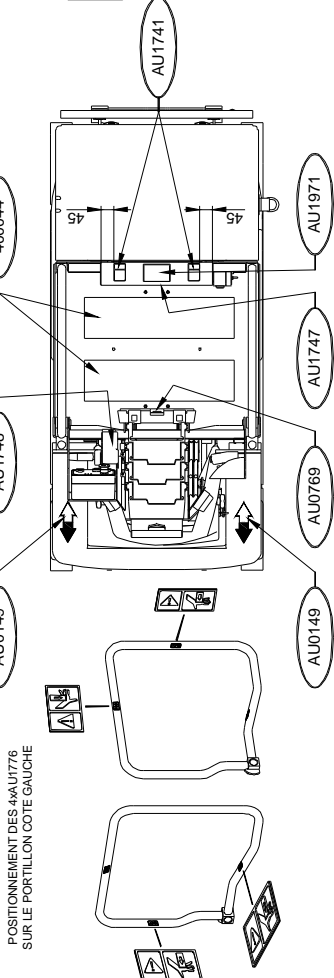
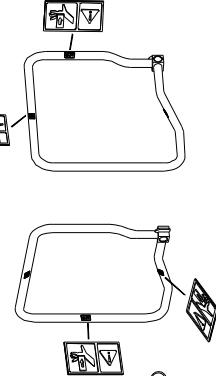

POSITIONNEMENT DES *AU1776
SUR LE PORTILLON COTE GAUCHE

CROSS REFERENCE CHART

TABLEAU DE CORRESPONDANCE

	Pages	Main assembly Assemblage supérieur
520099	4-2	SP0811
OPS482	1-1	SP0812
Paxxxx	7	
PC0378	2-1	
PC0403	2-2	
RM0059	4-1	SP0811
RM0090	2-2-1	PC0354
RM0091	2-2-2	PC0354
SP0386	5-2	SP0904
SP0387	5-3	SP0904
SP0390	3	
SP0802	2-2-3	PC0354
SP0803	2-2-4	PC0354
SP0804	2-2-5	PC0354
SP0805	2-2-6	PC0354
SP0808	6	
SP0811	4	
SP0812	1	
SP0813	5-1	SP0904
SP0883	2-2-7	PC0354
SP0900	5-4	SP0904
SP0901	6-1	SP0808
SP0902	6-2	SP0808
SP0904	5	
ST1628	5-1-1	SP0813