



# Illustrated Parts Manual

## ***Models***

***20EL***

***25EL***

***30EL***

***36EL***

***41EL***

***P/N - 3120783***

November 11, 2004

***ANSI***





# REVISION LOG

May 10, 1999 - Original Issue Of Manual  
November 15, 1999 - Revised (Manual edited to 0010555 Revision 19)  
June 30, 2000 - Revised (Manual edited to 0010555 Revision 22)  
July 1, 2000 - Updated (Changed Pages 3-6 and 3-12)  
August 24, 2000 - Revised (Manual edited to 0010555 Revision 23)  
April 12, 2001 - Revised (Manual edited to 0010555 Revision 27)  
January 10, 2002 - Revised (Manual edited to 0010555 Revision 29)  
March 1, 2002 - Revised (Manual edited to 0010555 Revision 31)  
June 12, 2002 - Revised (Manual edited to 0010555 Revision 34)  
October 31, 2002 - Revised (Manual edited to 0010555 Revision 36)  
February 19, 2003 - Revised (Manual edited to 0010555 Revision 37)  
July 15, 2003 - Revised (Manual edited to 0010555 Revision 43)  
April 29, 2004 - Revised (Manual edited to 0010555 Revision 45)  
November 11, 2004 - Revised (Manual edited to 0010555 Revision 47)

# REVISION LOG

# TABLE OF CONTENTS

FIGURE NO.	TITLE	PAGE NO.
<b>SECTION 1 - BASE</b>		<b>1-1</b>
1-1	BASE MOUNTED COMPONENTS INSTALLATION	1-2
1-2	TILTBACK INSTALLATION 36EL/41EL	1-8
<b>SECTION 2 - CONTROLS</b>		<b>2-1</b>
2-1	AC POWER COMPONENTS INSTALLATIONS	2-2
2-2	AC JUNCTION BOX ASSEMBLY	2-6
2-3	AC MOTOR/PUMP ASSEMBLY	2-8
2-4	DC POWER COMPONENTS INSTALLATION	2-12
2-5	DC POWER PACK INSTALLATION	2-16
2-5	BATTERY CHARGER ASSEMBLY	2-18
2-7	DC MOTOR/PUMP ASSEMBLY	2-20
2-8	CABLES AND CONTROLS INSTALLATION	2-24
<b>SECTION 3 - MAST</b>		<b>3-1</b>
3-1	MAST ASSEMBLY - 20EL	3-2
3-2	MAST ASSEMBLY - 25EL & 36EL	3-6
3-3	MAST ASSEMBLY - 30EL & 41EL	3-10
3-4	MAST MOUNTED COMPONENTS INSTALLATION	3-16
<b>SECTION 4 - PLATFORM</b>		<b>4-1</b>
4-1	STEP-IN MOLDED PLATFORM INSTALLATION	4-2
4-2	QUICK-CHANGE PLATFORM INSTALLATION	4-6
4-3	QUICK-CHANGE PLATFORM INSTALLATION WITH GULLWING GATE	4-8
4-4	OPTIONAL PLATFORM COMPONENT INSTALLATIONS	4-12
<b>SECTION 5 - CYLINDER</b>		<b>5-1</b>
5-1	LIFT CYLINDER ASSEMBLY (PRIOR TO S/N 17519)	5-2
5-2	LIFT CYLINDER ASSEMBLY (S/N 17519 TO PRESENT)	5-4
<b>SECTION 6 - HYDRAULIC</b>		<b>6-1</b>
6-1	HYDRAULIC DIAGRAM	6-2
<b>SECTION 7 - ELECTRICAL</b>		<b>7-1</b>
7-1	ELECTRICAL DIAGRAM LIST	7-2
7-2	ELECTRICAL DIAGRAM - 12VDC	7-4
7-3	ELECTRICAL DIAGRAM - 120VAC	7-6
<b>SECTION 8 - DECALS</b>		<b>8-1</b>
8-1	DECALS INSTALLATION	8-2
<b>SECTION 9 - RECOMMENDED SERVICE PARTS STOCK</b>		<b>9-1</b>
<b>SECTION 10 - SPECIAL OPTIONS</b>		<b>10-1</b>

# TABLE OF CONTENTS

FIGURE NO.

TITLE

PAGE NO.

# SECTION 1 BASE

TABLE OF CONTENTS		
FIGURE	DESCRIPTION	PAGE
1-1	BASE MOUNTED COMPONENTS INSTALLATION .....	1-2
1-2	TILT BACK INSTALLATION (36EL/41EL) .....	1-8

# SECTION 1 BASE

FIGURE 1-1. BASE MOUNTED COMPONENTS INSTALLATION

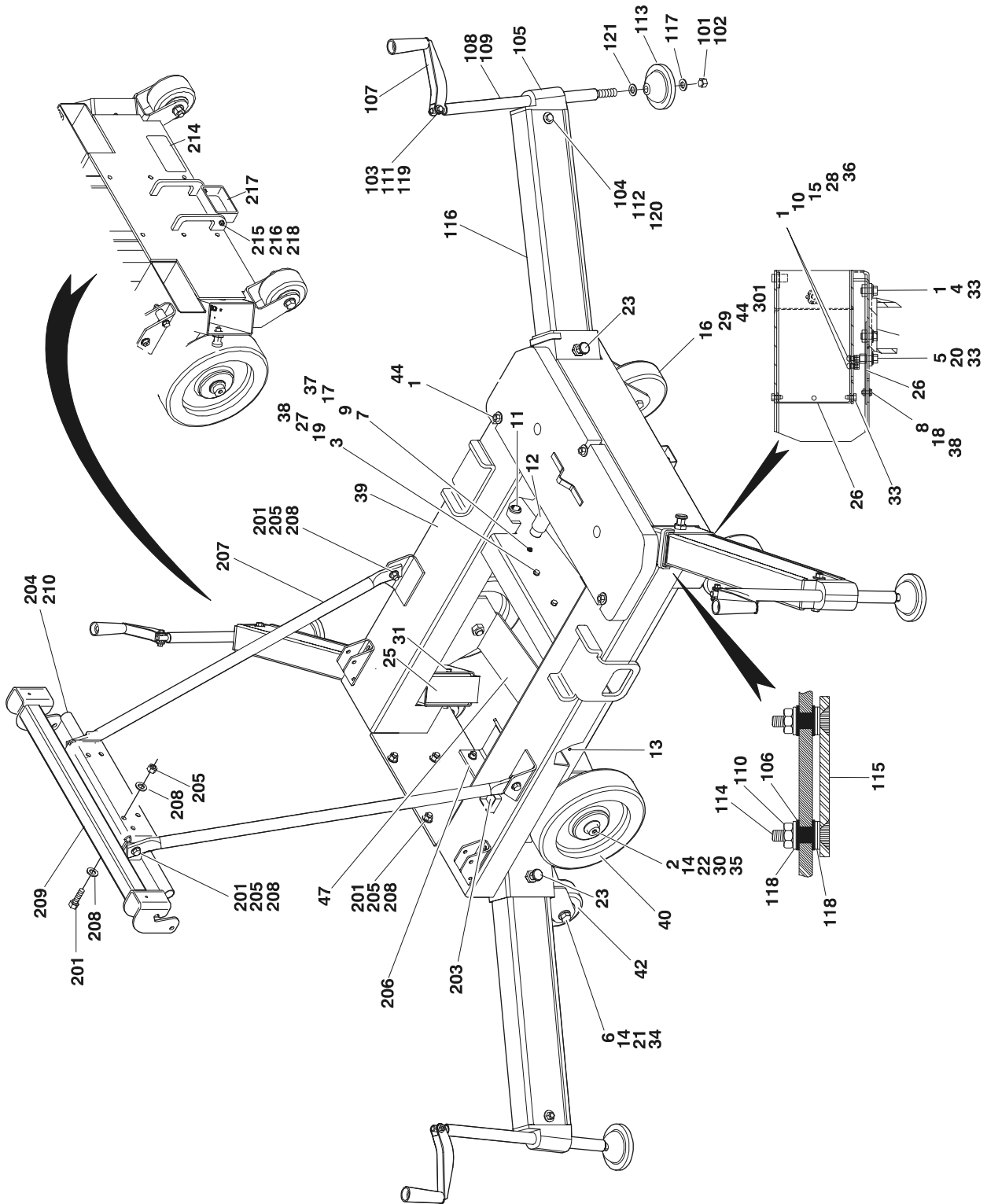



# SECTION 1 BASE

**FIGURE 1-1. BASE MOUNTED COMPONENTS INSTALLATION**

FIG & ITEM #	PART NUMBER	DESCRIPTION	QTY.	REV.
		<b>BASE ASSEMBLIES</b>	Ref.	
	0258180	<b>20EL/25EL (PRIOR TO S/N 17519)</b>	Ref.	J
	0271423	<b>20EL/25EL (S/N 17519 TO PRESENT)</b>	Ref.	F
	0258469	<b>30EL (PRIOR TO S/N 17519)</b>	Ref.	H
	0271424	<b>30EL (S/N 17519 TO PRESENT)</b>	Ref.	G
	0258470	<b>36EL/41EL (PRIOR TO S/N 17519)</b>	Ref.	H
	0271425	<b>36EL/41EL (S/N 17519 TO PRESENT)</b>	Ref.	G
1	0100011	Loctite #242	A/R	
2	0100019	Loctite #272	A/R	
3	0641406	Bolt 1/4"-20NC x 3/4"	2	
4	0641606	Bolt 3/8"-16NC x 3/4"	6	
5	0641607	Bolt 3/8"-16NC x 7/8"	2	
6	0641830	Bolt 1/2"-13NC x 3/4"	2	
7	0720805	Screw #8-24NC x 5/8"	6	
8	0721005	Screw #10-24NC	2	
9	1320043	Clamp	6	
10	Use 0962288	Bushing, Molded Nylon Insulator (S/N 16557 to Present) (Prior to S/N 16557 - Was P/N 2540024 - Grommet)	8	
11	2540025	Grommet	2	
12	2560088	Handle	2	
13	2920151	Light, Indicator	4	
14	3020022	Lithium, White	A/R	
15	3300379	Locknut, Brass #8-32NC	16	
16	3310405	Locknut #4-40NC	A/R	
17	3310805	Locknut #8-32NC (Prior to S/N 19233)	6	
18	3311005	Locknut #10-24NC	2	
19	3311405	Locknut 1/4"-20NC	2	
20	3311605	Locknut 3/8"-16NC	2	
21	3311805	Locknut 1/2"-13NC	2	
22	Use 3312002	Locknut 5/8"-11NC (Prior to S/N 12331)	2	
	3312002	Nut 5/8"-11NC (S/N 12331 to Present)	2	
23		Pin, Plunger Options:	4	
	3422369	Prior to S/N 12037		
	3422744	S/N 12037 to Present		
24	3570946	Plate, Cover	2	
25	3570947	Plate, Cover	2	
26	3570973	Plate, Cover	2	
27	3740106	Relay (Note: Part of p/n 4922421 Harness after S/N 14544)	1	
28	3900194	Screw, Brass #8-32NC x 5/8"	8	
29	3900212	Screw, Button #4-40NC	A/R	
30	3900255	Screw, Shoulder	2	
31	3941405	Screw, Self-Tapping	8	
32	4460234	Tie, Wire	A/R	
33	4711600	Flatwasher 3/8"	14	
34	4711800	Flatwasher 1/2"	4	
35	Use 4740525	Flatwasher 3/4" (S/N 20143 to Present) (Prior to S/N 20143 - Was P/N 4712200)	4	

# SECTION 1 BASE

**FIGURE 1-1. BASE MOUNTED COMPONENTS INSTALLATION (CONTINUED)**

FIG & ITEM #	PART NUMBER	DESCRIPTION	QTY.	REV.
36	4740434	Washer, Nylon #8	24	
37	4750800	Flatwasher #8 (Prior to S/N 19233)	12	
38	4751000	Flatwasher #10	8	
39		Base Weldment Options:	1	
	4845705	Prior to S/N 17519		
	4846388	S/N 17519 to Present		
40		Wheel Assembly - Stationary Options:	A/R	
	4860183	Stationary Wheel Used Prior to S/N 20788	2	
	7020083	Wheel, Replacement (1 Per Wheel)	2	
	7020084	Bearing (2 Per Wheel)	4	
	7012631	Bushing, Axle Spanner (1 Per Wheel)	2	
	4860246	Stationary Wheel Used S/N 20788 to Present (No Service Parts Available)	2	
41	Not Used			
42		Wheel Assembly - 4" Options:	A/R	
	4860185	4" Wheel Used Prior to S/N 20788	2	
	7020087	Wheel, Replacement (1 Per Wheel)	2	
	7020084	Bearing (2 Per Wheel)	4	
	7012631	Bushing, Axle Spanner (1 Per Wheel)	2	
	4860247	4" Wheel Used S/N 20788 to Present (No Service Parts Available)	2	
43	3571150	Plate, Wheel Spacer (S/N 12331 to Present)	1	
44	3020017	Lubricant (Used Prior to S/N 20788)	A/R	
45	4240032	Tie, Wire (Not Shown) (S/N 16285 to Present)	18	
46	2820086	Loom, Wire (Not Shown) (S/N 16285 to Present)	5.84ft/ 1.8m	
47	Use 4922752	Harness, Potted Relay (Not Shown) (Was P/N 4922421) (Prior to S/N 19239)	1	
		<b>OUTRIGGER ASSEMBLIES</b>	Ref.	
	0258466	<b>20EL/25EL</b>	Ref.	E
	0258467	<b>30EL</b>	Ref.	E
	0258468	<b>36EL/41EL</b>	Ref.	E
101	0100011	Loctite #242 (Not Shown)	A/R	
102	3300380	Locknut	1	
103	0641410	Bolt 1/4"-20NC x 1 1/4"	1	
104	0641624	3/8"-16NC x 3" (Prior to S/N 12074)	1	
	0641622	3/8"-16NC x 2 3/4" (S/N 12074 to Present)	1	
105	1220015	Cap, End	1	
106	Use 0962288	Bushing, Molded Nylon Insulator (S/N 16557 to Present) (Prior to S/N 16557 - Was 2540024 (Grommet))	2	
107	2560127	Handle	1	
108	2840019	Screw, Jack	1	
109	3020035	Lubricant, Silicone	A/R	
110	3300392	Locknut Brass #8-32NC	2	
111	3311405	Locknut 1/4"-20NC	1	
112	3311605	Locknut 3/8"-16NC	1	
113	3340712	Pad, Jack	1	

# SECTION 1 BASE

**FIGURE 1-1. BASE MOUNTED COMPONENTS INSTALLATION (CONTINUED)**

FIG & ITEM #	PART NUMBER	DESCRIPTION	QTY.	REV.
114	3900193	Screw, Countersunk #8-32NC x 3/4"	2	
115	4280291	Pad, Contact	1	
116		Beam, Outrigger Options:	1	
	4567601	20EL/25EL		
	4567602	30EL		
	4567603	36EL/41EL		
117	Not Used			
118	4740434	Washer, Nylon #8	5	
119	4751400	Flatwasher 1/4"	2	
120	4751600	Flatwasher 3/8"	A/R	
121	4891800	Flatwasher 1/2"	1	
122	3780200	O-Ring (S/N 16557 to Present)	2	
123	0100035	Loctite #222	A/R	
		<b>MAST SUPPORT INSTALLATIONS</b>	Ref.	
	0258543	<b>20EL (Prior to S/N 17519)</b>	Ref.	B
	0271429	<b>20EL (S/N 17519 to Present)</b>	Ref.	C
	0258544	<b>25EL (Prior to S/N 17519)</b>	Ref.	B
	0271430	<b>25EL (S/N 17519 to Present)</b>	Ref.	C
	0258545	<b>30EL (Prior to S/N 17519)</b>	Ref.	B
	0271431	<b>30EL (S/N 17519 to Present)</b>	Ref.	C
	0258546	<b>36EL (Prior to S/N 17519)</b>	Ref.	A
	0271432	<b>36EL (S/N 17519 to Present)</b>	Ref.	C
	0258547	<b>41EL (Prior to S/N 17519)</b>	Ref.	A
	0271433	<b>41EL (S/N 17519 to Present)</b>	Ref.	C
201	0641609	Bolt 3/8"-16NC x 1 1/8"	A/R	
202	Not Used			
203	2420140	Gauge, Level	1	
204	2560088	Handle (Models 20EL/25EL/30EL Only)	2	
205	3311605	Locknut 3/8"-16NC	14	
206	3570971	Plate, Cover	1	
207	4567508	Brace	2	
208	4711600	Flatwasher 3/8"	28	
209		Support Weldment Options:		
	4845715	20EL/25EL/30EL	1	
	4845763	36EL/41EL	1	
210	0100001	Adhesive (Models 20EL/25EL/30EL Only) (S/N 12074 to Present)	A/R	
211 to 213	Not Used			
214	1704582	Decal, Manual Descent	1	
215	0641408	Screw 1/4"	4	
216	3311405	Locknut 1/4"	4	
217	4568433	Tube, Valve Protection	1	
218	4751400	Flatwasher 1/4"	8	

# SECTION 1 BASE

FIGURE 1-1. BASE MOUNTED COMPONENTS INSTALLATION (CONTINUED)

FIG & ITEM #	PART NUMBER	DESCRIPTION	QTY.	REV.
		<b>FRONT WHEEL ASSEMBLIES</b>	Ref.	
301		<b>Wheel Assembly Options:</b>	2	
	4860184	<b>Swivel Non-Locking Wheel Used Prior to S/N 20788</b>	2	
	7020017	Swivel Rig (1 Per Assembly)	2	
	7020086	Wheel, Replacement (1 Per Assembly)	2	
	7020084	Bearing (2 Per Wheel)	4	
	7012631	Bushing, Axle Spanner (1 Per Assembly)	2	
	7012630	Axle Kit (1 Per Assembly)	2	
	4860245	<b>Swivel Non-Locking Wheel Used S/N 20788 to Present</b> (No Service Parts Available)	2	

SECTION 1 BASE

# SECTION 1 BASE

FIGURE 1-1. BASE MOUNTED COMPONENTS INSTALLATION (CONTINUED)

FIG & ITEM #	PART NUMBER	DESCRIPTION	QTY.	REV.

**S  
E  
C  
T  
I  
O  
N  
  
1  
  
B  
A  
S  
E**

# SECTION 1 BASE

FIGURE 1-2. TILTBACK INSTALLATION (36EL/41EL)

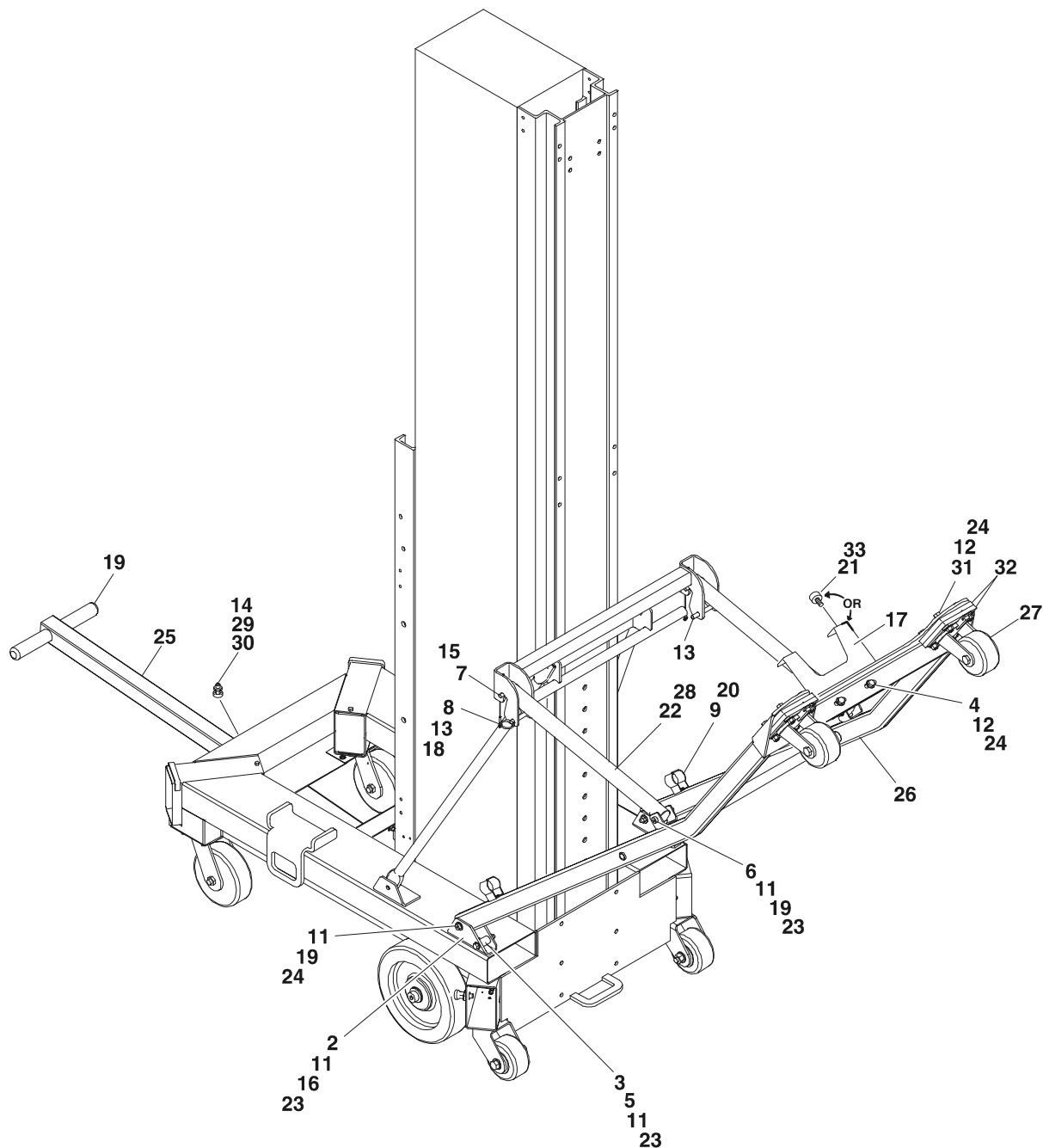

# SECTION 1 BASE

**FIGURE 1-2. TILTBACK INSTALLATION (36EL/41EL)**

FIG & ITEM #	PART NUMBER	DESCRIPTION	QTY.	REV.
	0258406	<b>TILTBACK INSTALLATION 36AM/41AM</b>	Ref.	G
1	0100019	Loctite #272 (Not Shown)	A/R	
2	0630383	Carriage Bolt, 5/16"-18NC	4	
3	0641518	Bolt 5/16"-18NC x 2 1/4"	2	
4	0641608	Bolt 3/8"-16NC x 1"	10	
5	0962195	Bushing, Tiltstop	2	
6	0962196	Bushing, Shock Mount	2	
7	0962197	Bushing, Shock Mount	2	
8	1060380	Cable, Lantard	2	
9	1320215	Clamp, Stowage	2	
10	2560088	Grip, Handle	2	
11	3311505	Locknut, 5/16"-18NC	10	
12	3311605	Locknut, 3/8"-16NC	10	
13	3420934	Pin, Quick Release	2	
14	3422369	Plunger Pin (Prior to S/N 12209)	1	
15	3422370	Pin, Grooved	2	
16	3570927	Plate, Tilt Back Mount	2	
17	3570949	Plate, Stop	1	
18	3820024	Rivet	2	
19	3900111	Screw, Shoulder	4	
20	3941004	Screw, Self Tapper	4	
21		Hardware Option:		
	Use 4060807	Shield, Flex Trim (Was P/N 4060805) (Prior to S/N 19171)	2ft	
	4060807	(S/N 19171 to S/N 19855)	2ft	
	0940049	(S/N 19855 to Present) (Stopper, Rubber)	2	
22	4567599	Tube, Shock Cover	2	
23	4711500	Flatwasher, 5/16" Narrow	A/R	
24	4711600	Flatwasher, 3/8" Narrow	24	
25	4845706	T-Bar Weldment	1	
26	4845762	Tiltback Weldment	1	
27	Use 4860143	Wheel, Caster (Was P/N 4860187) (Prior to S/N 19171) (S/N 19171 to Present)	2	
28	4160173	Spring, Gas Shock	2	
29	3422744	Plunger Pin (S/N 12209 to Present)	1	
30	3520163	Cap, Tube	2	
31	0641614	Bolt 3/8"-16NC x 1 3/4" (Prior to S/N 19171)	8	
32		Plate, Spacer Options: (Prior to S/N 19171)	4	
	3572370	(S/N 19171 to Present)		
	Not Used	(S/N 19171 to Present)		
33	3311501	Nut 5/16-18NC (S/N 19855 to Present)	1	

# SECTION 1 BASE

FIGURE 1-2. TILTBACK INSTALLATION (36EL/41EL) (CONTINUED)

FIG & ITEM #	PART NUMBER	DESCRIPTION	QTY.	REV.

**S  
E  
C  
T  
I  
O  
N  
  
1  
  
B  
A  
S  
E**



# SECTION 2 CONTROLS

## TABLE OF CONTENTS

FIGURE	DESCRIPTION	PAGE
2-1	AC POWER COMPONENTS INSTALLATIONS . . . . .	2-2
2-2	AC JUNCTION BOX ASSEMBLY . . . . .	2-6
2-3	AC MOTOR/PUMP ASSEMBLY . . . . .	2-8
2-4	DC POWER COMPONENTS INSTALLATIONS . . . . .	2-12
2-5	DC POWER PACK INSTALLATION . . . . .	2-16
2-6	BATTERY CHARGER ASSEMBLY . . . . .	2-18
2-7	DC MOTOR/PUMP ASSEMBLY . . . . .	2-20
2-8	CABLES AND CONTROLS INSTALLATION . . . . .	2-24

# SECTION 2 CONTROLS

FIGURE 2-1. AC POWER COMPONENTS INSTALLATION

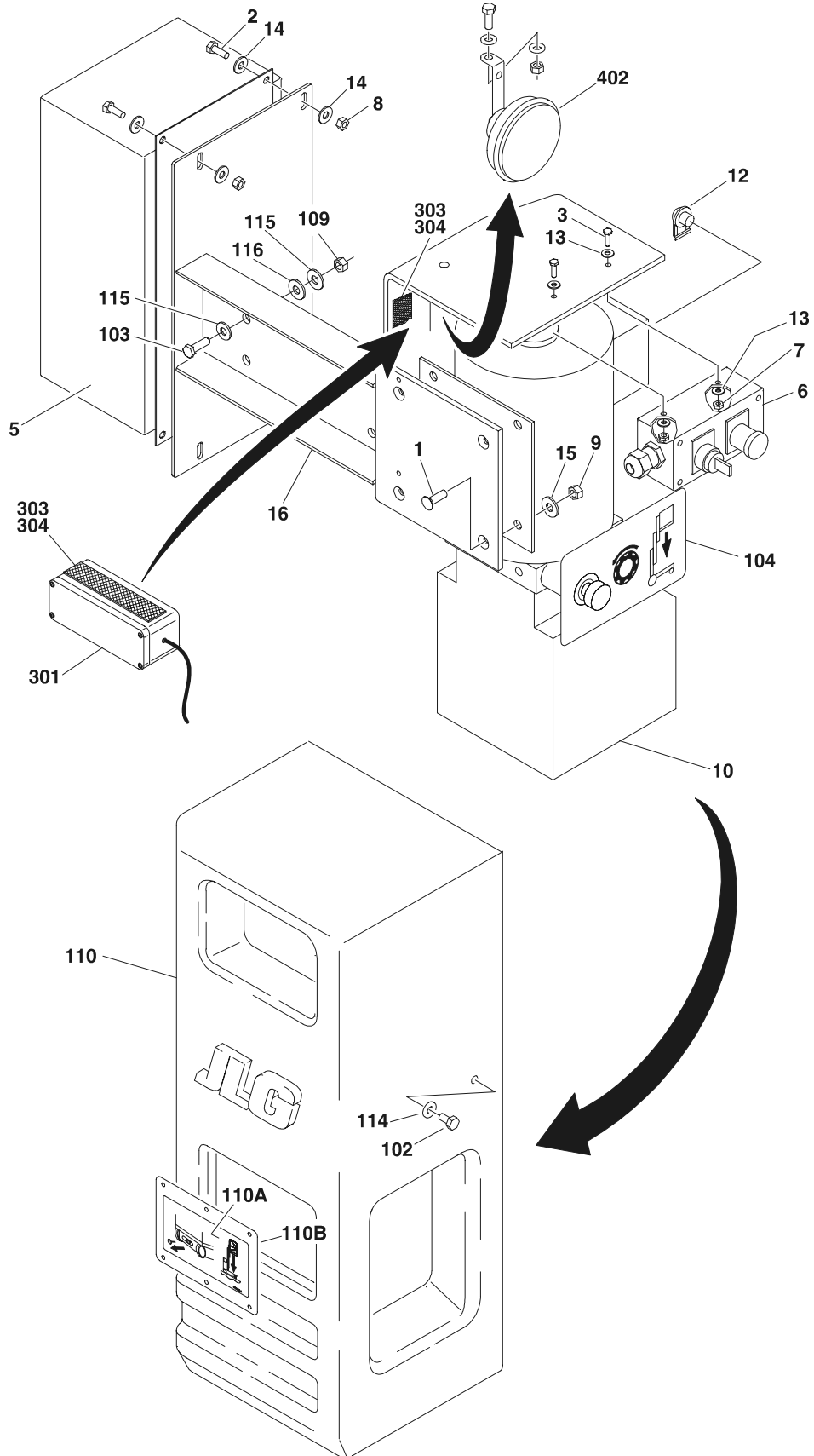

SECTION 2 CONTROLS

# SECTION 2 CONTROLS

**FIGURE 2-1. AC POWER COMPONENTS INSTALLATION**

FIG & ITEM #	PART NUMBER	DESCRIPTION	QTY.	REV.
		<b>POWERPACK ASSEMBLY OPTIONS:</b>	Ref.	
	0258434	<b>120 VOLT (Prior to S/N 17519)</b>	Ref.	C
	0271131	<b>120 VOLT (S/N 17519 to Present)</b>	Ref.	B
1	0630486	Screw, Counter Sunk	4	
2	0641406	Bolt 1/4"-20NC x 3/4"	4	
3	0721006	Screw	2	
4	0721014	Screw (Prior to S/N 12076)	1	
5	0860933	Junction Box Assembly (See Figure 2-2 for Breakdown)	1	
6		Ground Control Box Assembly Options:	1	
	0861212	Prior to S/N 20143		
	0861305	S/N 20143 to Present		
	7020078	Switch, Push-Pull (Stop)	1	
	7020096	Legend Plate, "Stop"	1	
	7020097	Legend Plate, "Power/Off/On"	1	
		Switch, Key Options:	1	
	7020098	Prior to S/N 20143		
	4360467	S/N 20143 to Present		
		Key, Replacement Options:	1	
	7016339	Prior to S/N 20143		
	2860030	S/N 20143 to Present		
	7020090	Connector, Strain Relief	1	
	7020093	Screw m3 x 25	4	
	7020094	Lid	1	
7	3311005	Locknut #10-24NC	A/R	
8	3311405	Locknut 1/4"-20NC	4	
9	3311505	Locknut 5/16"-18NC	4	
10		Pump/Motor Assembly Options (See Figure 2-3 for Breakdown):	1	
	3600281	Prior to S/N 12829		
	3600292	S/N 12829 to S/N 17519		
	3600322	S/N 17519 to Present		
11	3740113	Relay, Timer (Prior to S/N 12076 Only)	1	
12	4460566	Terminal, 90 Degrees	1	
13	4751000	Flatwasher #10	A/R	
14	4751400	Flatwasher 1/4"	8	
15	4751500	Flatwasher 5/16"	4	
16	4845712	Plate, Mounting	1	
		<b>POWERPACK INSTALLATION OPTIONS:</b>	Ref.	
	0258683	<b>20EL (Prior to S/N 17519)</b>	Ref.	C
	0271139	<b>20EL (S/N 17519 to Present)</b>	Ref.	E
	0258478	<b>25EL/30EL/36EL/41EL (Prior to S/N 17519)</b>	Ref.	B
	0271137	<b>25EL/30EL/36EL/41EL (S/N 17519 to Present)</b>	Ref.	D
101	Not Used			
102	0641404	Bolt 1/4"-20NC x 1/2"	4	
103		Bolt Options:	4	
	0641610	Bolt 3/8"-16NC x 1 1/4" (20EL)		

SECTION 2 CONTROLS

# SECTION 2 CONTROLS

**FIGURE 2-1. AC POWER COMPONENTS INSTALLATION**

FIG & ITEM #	PART NUMBER	DESCRIPTION	QTY.	REV.
104	0641608	Bolt 3/8"-16NC x 1" (25EL/30EL/36EL/41EL)		
105 to 108	1702353	Decal - Manual Descent (Prior to S/N 17519 Only)	1	
109	Not Used			
110	3311605	Locknut 3/8"-16NC	4	
		Shield, Pump Cover	1	
	4060875	(Prior to S/N 19688)		
	4061024	(S/N 19688 to Present)		
110A	1704582	Decal (S/N 19688 to Present Only)		
110B	9984088	Cover (S/N 19688 to Present Only)		
111 to 113	Not Used			
114	4711400	Flatwasher 1/4"	4	
115	4711600	Flatwasher 3/8"	8	
116		Flatwasher Options:	A/R	
	4751600	Flatwasher 3/8" Wide (20EL Only) (Prior to S/N 15553)	A/R	
	Not Required	(25EL/30EL/36EL/41EL)	0	
117	Not Used			
118		Shim Options (S/N 15553 to Present):	2	
	4070984	20EL		
	Not Required	25EL/30EL/36EL/41EL		
	0258482	<b>AUXILIARY LOWERING INSTALLATION</b>	Ref.	A
201 to 300	Not Used			
301	0861213	Box, Power Down	1	
	0400181	Battery	2	
	4460320	Connector, Amp	1	
	4460267	Pin, Amp	2	
302	Not Used			
303	4420064	Velcro, Loop	.3ft/.09m	
304	4420065	Velcro, Hook	.3ft/.09m	
	0271373	<b>FLOOR BRAKE ALARM INSTALLATION</b>	Ref.	A
401	0100011	Loctite #242 (Not Shown)	A/R	
402	0140022	Alarm, Horn	1	
403	4922583	Harness, Brake Alarm (Not Shown)	1	

**SECTION 2 CONTROLS**

# SECTION 2 CONTROLS

FIGURE 2-1. AC POWER COMPONENTS INSTALLATION

FIG & ITEM #	PART NUMBER	DESCRIPTION	QTY.	REV.

**S  
E  
C  
T  
I  
O  
N  
  
2  
  
C  
O  
N  
T  
R  
O  
L  
S**

# SECTION 2 CONTROLS

FIGURE 2-2. AC JUNCTION BOX ASSEMBLY

SECTION 2 CONTROLS

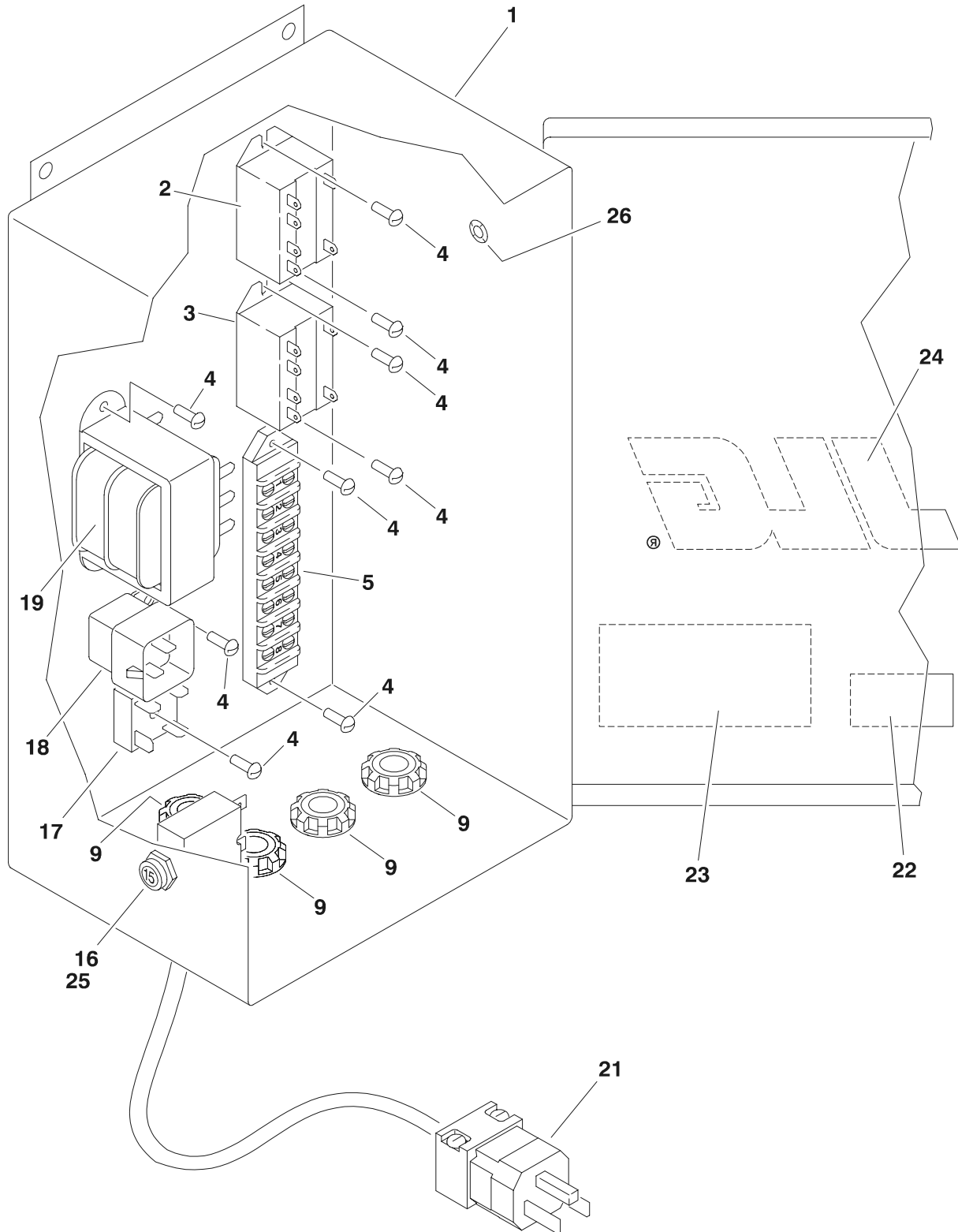

# SECTION 2 CONTROLS

**FIGURE 2-2. AC JUNCTION BOX ASSEMBLY**

FIG & ITEM #	PART NUMBER	DESCRIPTION	QTY.	REV.
		<b>JUNCTION BOX ASSEMBLY OPTIONS:</b>	Ref.	
	0860933	<b>120 VOLT</b>	Ref.	9/H
1		Box with Lid Options:	1	
	0860911	Prior to S/N 13463		
	0860943	S/N 13463 to Present		
2	3740094	Relay, Starter 12 VDC	1	
3	3740093	Relay, Starter 115VAC	1	
4	3910808	Screw #8-32NF x 1/2"	10	
5	4460565	Strip, Terminal	1	
6	Not Used			
7	Not Used			
8	Not Used			
9	4460633	Connector, Strain Relief	A/R	
10	Not Used			
11	Not Used			
12	Not Used			
13	Not Used			
14	Not Used			
15	Not Used			
16	4360161	Circuit Breaker 110 Volt - 20 Amp	1	
17	4360376	Rectifier	1	
18	3740049	Relay	1	
19		Transformer Options:	1	
	Use 4530013	Prior to S/N 14485 (Was P/N 4530010 115/230VAC to 12VDC Transformer)		
	4530013	S/N 14485 to Present (115/230VAC to 16VDC Transformer)		
20	Not Used			
21	4921663	Harness, Wiring	1	
22	1702569	Decal - 110 Volt (Not Shown)	1	
23	1702120	Decal - Wire Size	1	
24	1702365	Decal - JLG	1	
25	3520028	Plug 1/2"	1	
26	3520034	Plug, Hole	4	

**SECTION 2 CONTROLS**

# SECTION 2 CONTROLS

FIGURE 2-3. AC MOTOR/PUMP ASSEMBLY

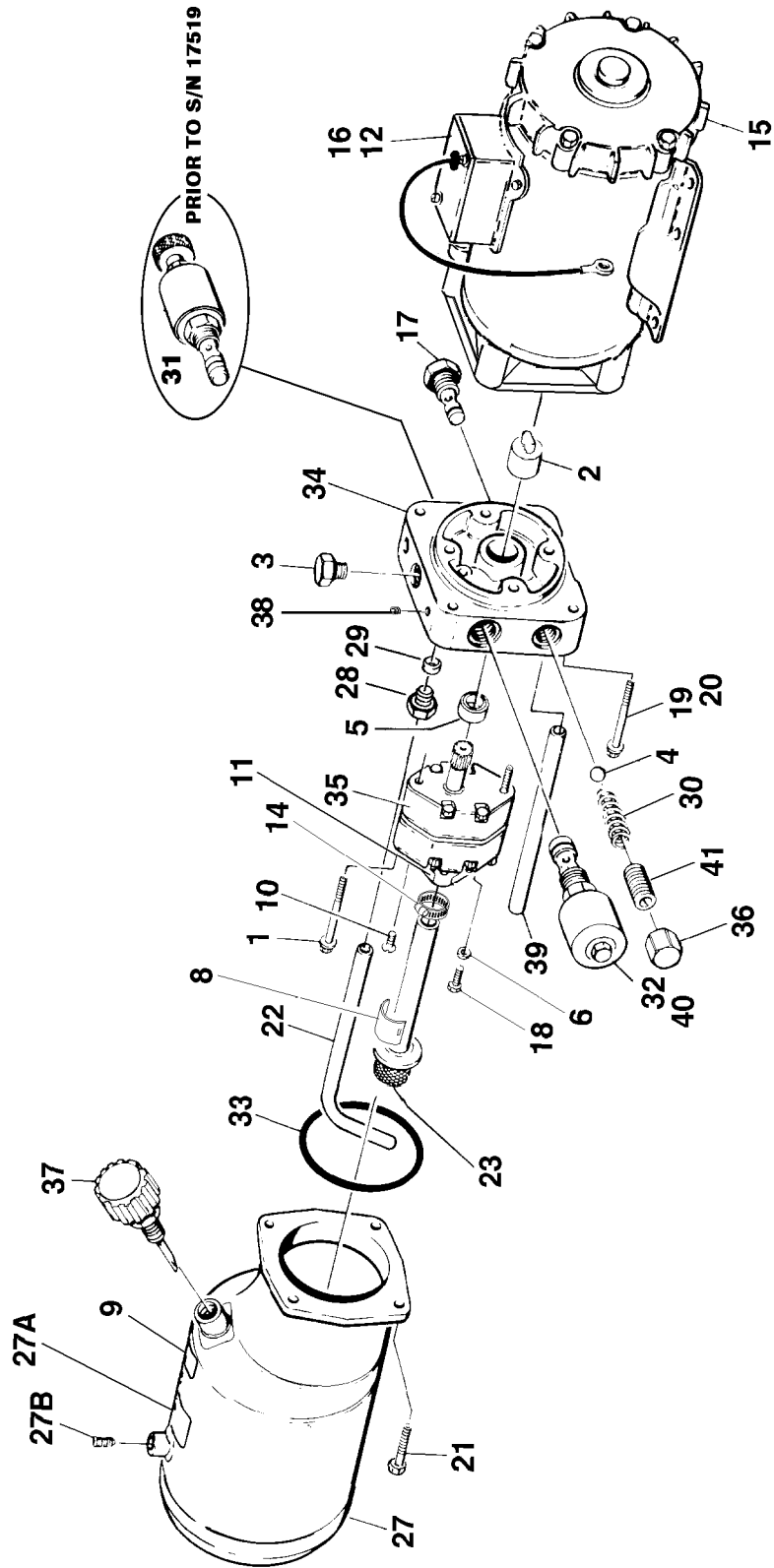



# SECTION 2 CONTROLS

**FIGURE 2-3. AC MOTOR/PUMP ASSEMBLY**

FIG & ITEM #	PART NUMBER	DESCRIPTION	QTY.	REV.
		<b>MOTOR/PUMP ASSEMBLY OPTIONS:</b>	Ref.	
	3600281	<b>Prior to S/N 12829</b>	Ref.	A
	3600292	<b>S/N 12829 to 17519</b>	Ref.	C
	3600322	<b>S/N 17519 to Present</b>	Ref.	C
1		Bolt Options:	2	
	7013713	5/16"-24NF x 2 3/4" (Prior to S/N 17519) 3600281/3600292 Assemblies		
	7022222	5/16"-24NF x 2 1/2" (S/N 17519 to Present) 3600322 Assemblies		
2	7016735	Coupling	1	
3	7013714	Plug	1	
4	7013715	Ball	1	
5	7013716	Seal	1	
6		Washer Options:	1	
	7013717	3600281/3600292 Assemblies (Prior to S/N 17519)		
	7022217	3600322 Assemblies (S/N 17519 to Present)		
7	Not Used			
8	7013722	Magnet	1	
9	7016713	Decal - Fill Line	1	
10		Screw Options:	2	
	7013728	3600281/3600292 Assemblies (Prior to S/N 17519)		
	Not Required	3600322 (S/N 17519 to Present)		
11		Cover Options:	1	
	7016770	3600281/3600292 Assemblies (Prior to S/N 17519)		
	Not Required	3600322 (S/N 17519 to Present)		
12		Gasket Options:	A/R	
	7016764	3600281 Assemblies (Prior to S/N 12829)	1	
	7016793	3600292 Assemblies (S/N 12829 to 17519)	1	
	Not Required	3600322 Assemblies (S/N 17519 to Present)		
13	Not Used			
14	7016771	Clamp	1	
15	7016774	Motor	1	
16		Cover, Switch Box Options:	A/R	
	7013787	3600281 Assemblies (Prior to S/N 12829)	1	
	7016787	3600292 Assemblies (S/N 12829 to 17519)	1	
	7016787	3600322 Assemblies (S/N 17519 to Present)		
17	7013708	Cartridge, Valve - Check	1	
18	7016720	Bolt 5/16"-18NC x 1" (Prior to S/N 17519)	1	
19	7016757	Bolt M6-1.0 35MM	4	
20	7016758	Lockwasher 1/4"	4	
21	7016721	Bolt #12-24NC x 1/2"	4	
22	7013795	Tube, Return	1	
23	7016773	Plumbing Assembly - Inlet	1	
24	Not Used			
25	Not Used			
26	Not Used			

**SECTION 2 CONTROLS**

# SECTION 2 CONTROLS

**FIGURE 2-3. AC MOTOR/PUMP ASSEMBLY (CONTINUED)**

FIG & ITEM #	PART NUMBER	DESCRIPTION	QTY.	REV.
27		Tank Options:	1	
	7016775	3600281/3600292 Assemblies (Prior to S/N 17519)		
	7022219	3600322 (S/N 17519 to Present)		
27A	7016776	Decal - Caution	1	
27B	7016759	Plug	1	
28	7013792	Nut, Tube Compression	1	
29	7013793	Sleeve, Tube Compression	1	
30	7013733	Spring	1	
31		Valve, Manual Descent Options:	1	
	7013764	3600281/3600292 Assemblies (Prior to S/N 17519)		
	Not Required	3600322 (S/N 17519 to Present)		
32	7016751	Cartridge, Valve - Solenoid	1	
33	7013743	O-Ring	1	
34		End Head Options:	1	
	7016753	3600281/3600292 Assemblies (Prior to S/N 17519)		
	7022220	3600322 (S/N 17519 to Present)		
35		Pump Assembly Options:	1	
	7013747	3600281/3600292 Assemblies (Prior to S/N 17519)		
	7022221	3600322 (S/N 17519 to Present)		
36	7013779	Cap, Relief	1	
37	7016714	Breather	1	
38	7013720	Plug	2	
39	7013726	Tube, Return	A/R	
40	7016755	Valve	1	
41	7013770	Screw, Adjustment	1	

**SECTION 2 CONTROLS**

# SECTION 2 CONTROLS

FIGURE 2-3. AC MOTOR/PUMP ASSEMBLY (CONTINUED)

FIG & ITEM #	PART NUMBER	DESCRIPTION	QTY.	REV.

**S  
E  
C  
T  
I  
O  
N  
  
2  
  
C  
O  
N  
T  
R  
O  
L  
S**

# SECTION 2 CONTROLS

FIGURE 2-4. DC POWER COMPONENTS INSTALLATION

SECTION 2 CONTROLS

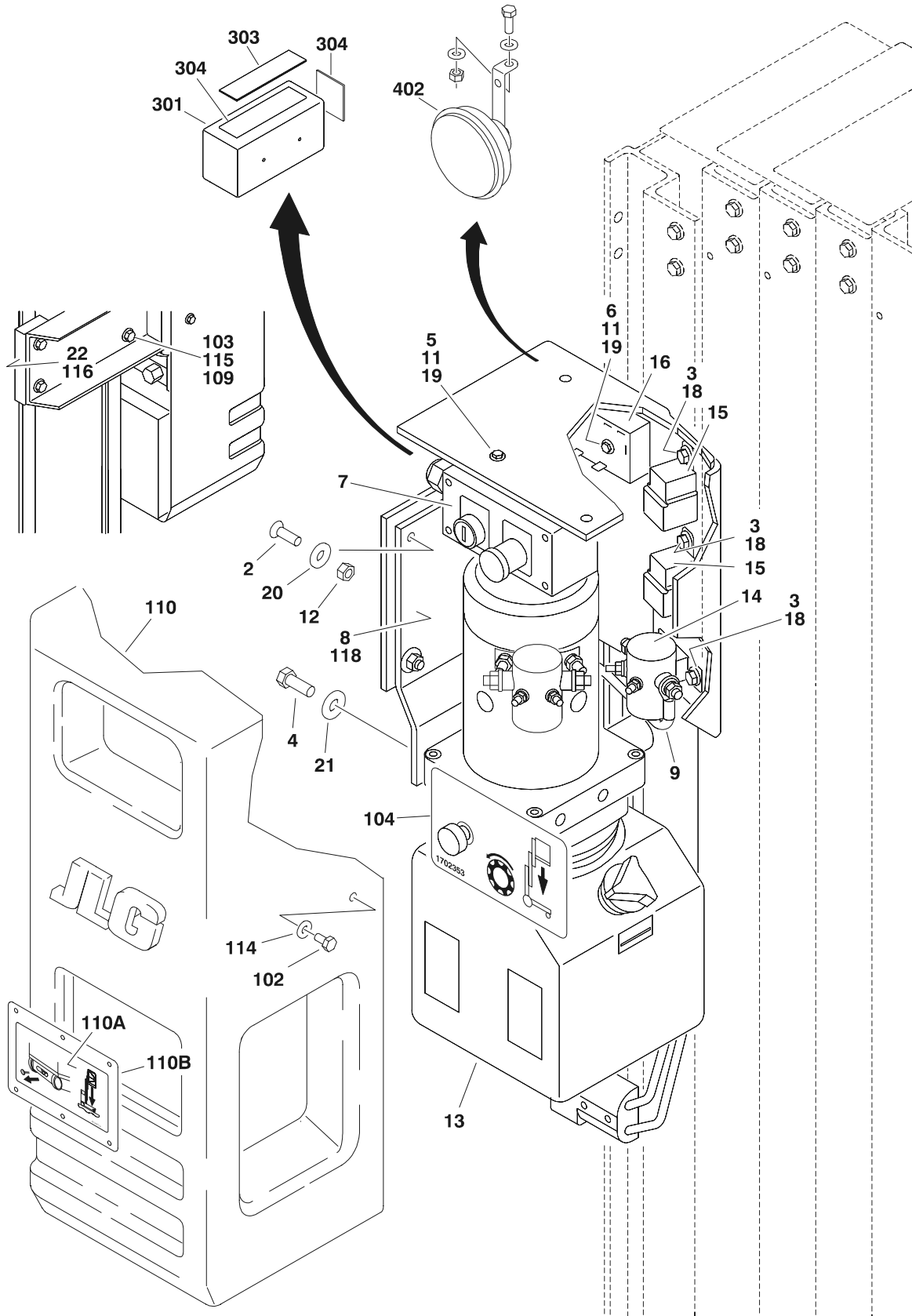

# SECTION 2 CONTROLS

**FIGURE 2-4. DC POWER COMPONENTS INSTALLATION**

FIG & ITEM #	PART NUMBER	DESCRIPTION	QTY.	REV.
		<b>POWER PACK ASSEMBLY OPTIONS:</b>	Ref.	
	0258438	<b>Prior to S/N 17519</b>	Ref.	A
	0271130	<b>S/N 17519 to Present</b>	Ref.	D
1	0100011	Loctite, #242 (Not Shown)	A/R	
2	0630486	Screw, Countersunk	4	
3	0641403	Bolt 1/4"-20NC x 3/8"	3	
4		Bolt Options:	2	
	0641608	3/8"-16NC x 1" (Prior to S/N 17519)		
	0641606	3/8"-16NC x 3/4" (S/N 17519 to Present)		
5	0721006	Screw	2	
6	0721014	Screw (Prior to S/N 17519)	1	
7		Ground Control Box Assembly Options:	1	
	0861212	Prior to S/N 20143		
	0861305	S/N 20143 to Present		
	7020078	Switch, Push-Pull (Stop)	1	
	7020096	Legend Plate, "Stop"	1	
	7020097	Legend Plate, "Power/Off/On"	1	
		Switch, Key Options:	1	
	7020098	Prior to S/N 20143		
	4360467	S/N 20143 to Present		
		Key, Replacement Options:	1	
	7016339	Prior to S/N 20143		
	2860030	S/N 20143 to Present		
	7020090	Connector, Strain Relief	1	
	7020093	Screw m3 x 25	4	
	7020094	Lid	1	
8	0902054	Plate, Mounting	1	
9	1060518	Cable, Battery (Prior to S/N 17519 Only)	1	
10	1060571	Cable Assembly - Battery	1	
11	3311005	Locknut #10-24NC	A/R	
12	3311505	Locknut 5/16"-18NC	4	
13		DC Motor/Pump Assembly Options: (See Figure 2-7 for Breakdown)	1	
	3600273	Prior to S/N 17519		
	3600320	S/N 17519 to Present		
14	3740013	Solenoid (Prior to S/N 17519)	1	
15		Relay Options:	A/R	
	3740080	Relay, Bosch (Prior to S/N 17519)		
	3740049	(Skirted type) S/N 17519 to Present		
16	3740113	Relay, Timer (Prior to S/N 17519)	1	
17	4567605	Tube, Butyrate (Not Shown) (Prior to S/N 17519)	2	
18		Washer 1/4" Options:		
	4711400	Prior to S/N 17519	3	
	4751400	S/N 17519 to Present	1	
19	4751000	Washer #10	A/R	
20	4751500	Washer 5/16"	4	
21	4751600	Washer 3/8"	2	
22	4845714	Bracket, Pump Mounting	1	

**SECTION 2 CONTROLS**

# SECTION 2 CONTROLS

**FIGURE 2-4. DC POWER COMPONENTS INSTALLATION (CONTINUED)**

FIG & ITEM #	PART NUMBER	DESCRIPTION	QTY.	REV.
23	0641404	Bolt 1/4"-20NC x 1/2" (S/N 17519 to Present) (Not Shown)	1	
24	1320224	Clamp, Cable (S/N 17519 to Present) (Not Shown)	1	
25		Harness, Pump 12V DC Options: (Not Shown)	1	
	4922605	S/N 17519 to S/N 19378		
	4922740	S/N 19378 to Present		
		<b>POWERPACK INSTALLATION OPTIONS:</b>	Ref.	
	0258683	<b>20EL (Prior to S/N 17519)</b>	Ref.	C
	0271139	<b>20EL (S/N 17519 to Present)</b>	Ref.	E
	0258478	<b>25EL/30EL/36EL/41EL (Prior to S/N 17519)</b>	Ref.	B
	0271137	<b>25EL/30EL/36EL/41EL (S/N 17519 to Present)</b>	Ref.	D
101	Not Used			
102	0641404	Bolt 1/4"-20NC x 1/2"	4	
103		Bolt Options:	4	
	0641610	Bolt 3/8"-16NC x 1 1/4" (20EL)		
	0641608	Bolt 3/8"-16NC x 1" (25EL/30EL/36EL/41EL)		
104	1702353	Decal - Manual Descent (Prior to S/N 17519 Only)	1	
105 to 108	Not Used			
109	3311605	Locknut 3/8"-16NC	4	
110		Shield, Pump Cover	1	
	4060875	(Prior to S/N 19688)		
	4061024	(S/N 19688 to Present)		
110A	1704582	Decal (S/N 19688 to Present Only)		
110B	9984088	Cover (S/N 19688 to Present Only)		
111 to 113	Not Used			
114	4711400	Flatwasher 1/4"	4	
115	4711600	Flatwasher 3/8"	8	
116		Flatwasher Options:	A/R	
	4751600	Flatwasher 3/8" Wide (20EL Only) (Prior to S/N 15553)	A/R	
	Not Required	(25EL/30EL/36EL/41EL)	0	
117	Not Used			
118		Shim Options (S/N 15553 to Present):	2	
	4070984	20EL		
	Not Required	25EL/30EL/36EL/41EL		
	0258482	<b>AUXILIARY LOWERING INSTALLATION</b>	Ref.	A
201 to 300	Not Used			
301	0861213	Box, Power Down	1	
	0400181	Battery	2	
	4460320	Connector, Amp	1	
	4460267	Pin, Amp	2	
302	Not Used			
303	4420064	Velcro, Loop	.3ft/.09m	
304	4420065	Velcro, Hook	.3ft/.09m	

SECTION 2 CONTROLS

# SECTION 2 CONTROLS

**FIGURE 2-4. DC POWER COMPONENTS INSTALLATION (CONTINUED)**

FIG & ITEM #	PART NUMBER	DESCRIPTION	QTY.	REV.
	0271373	<b>FLOOR BRAKE ALARM INSTALLATION</b>	Ref.	A
401	0100011	Loctite #242 (Not Shown)	A/R	
402	0140022	Alarm, Horn	1	
403	4922583	Harness, Brake Alarm (Not Shown)	1	

**SECTION 2 CONTROLS**

# SECTION 2 CONTROLS

FIGURE 2-5. DC POWER PACK INSTALLATION

SECTION 2 CONTROLS

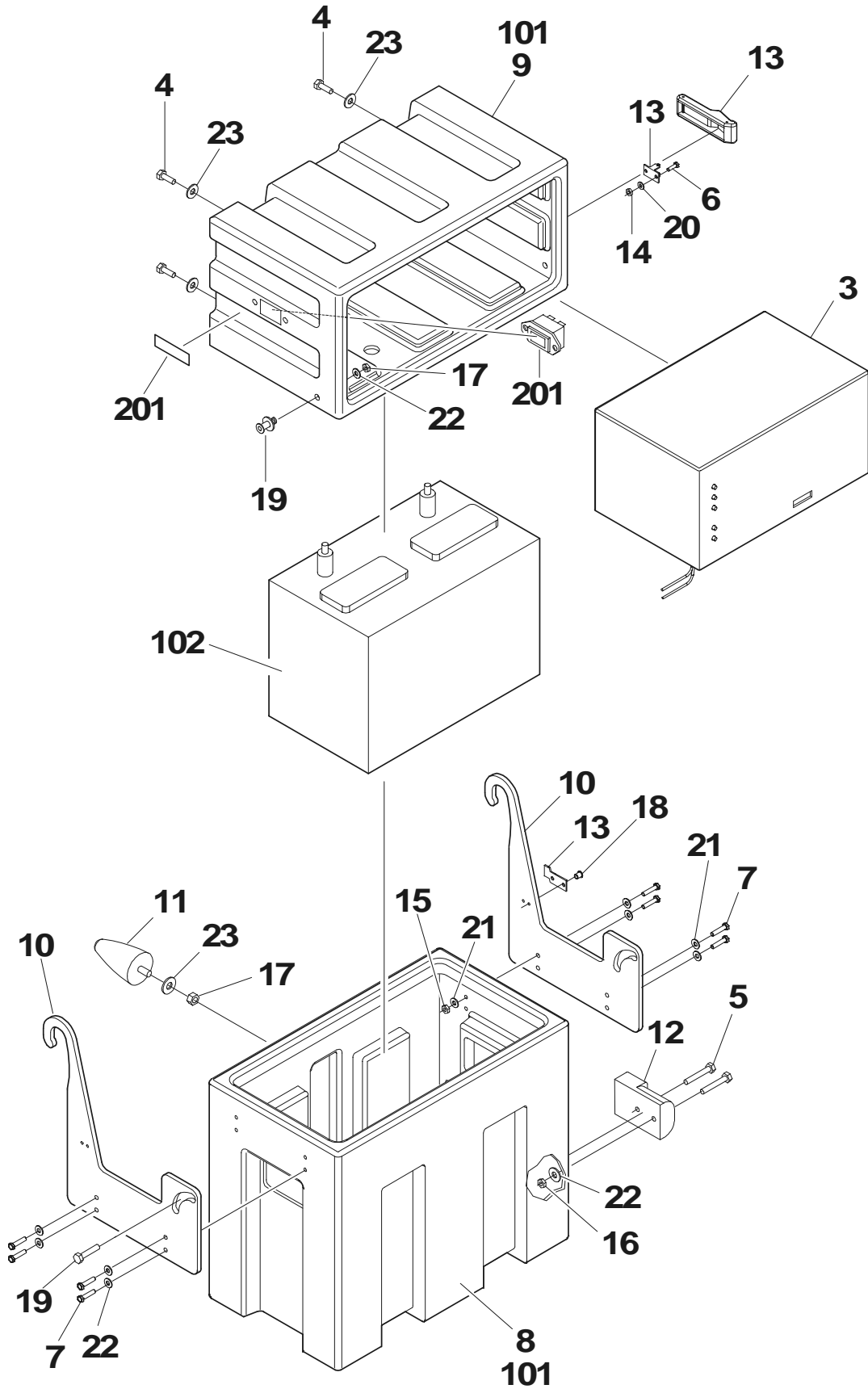



# SECTION 2 CONTROLS

**FIGURE 2-5. DC POWER PACK INSTALLATION**

FIG & ITEM #	PART NUMBER	DESCRIPTION	QTY.	REV.
	0400223	<b>BATTERY BOX AND CHARGER ASSEMBLY</b>	Ref.	B
1	0100011	Loctite, #242 (Not Shown)	A/R	
2	Not Used			
3	0400176	Charger Assembly (See Figure 2-6 for Breakdown)	1	
4	0641406	Bolt, 1/4"-20NC x 3/4"	4	
5	0641412	Bolt, 1/4"-20NC x 1 1/2"	2	
6	0720805	Screw, #8-24NC x 5/8"	2	
7	0721008	Screw, #10-24NC	8	
8	0861192	Box, Molded Battery	1	
9	0861193	Box, Molded Battery Charger	1	
10	0902442	Bracket, Hanger	2	
11	0940085	Bumper, Stop	1	
12	1060570	Cable Assembly - Battery	1	
13	2940111	Latch, Soft Draw	1	
14	3310805	Locknut #8-32NC	2	
15	3311005	Locknut #10-24NC	8	
16	3311401	Nut, 1/4"-20NC (Prior to S/N 23032)	2	
	3311405	Locknut, 1/4"-20NC (S/N 23032 to Present)	2	
17	3311501	Nut 5/16"-18NC (Prior to S/N 23032)	3	
	3311505	Locknut 5/16"-18NC (S/N 23032 to Present)	3	
18	3820001	Rivet,.125 x.25	2	
19	3900190	Screw, Shoulder	2	
20	4750800	Washer, #8 Flat	2	
21	4751000	Washer, #10 Flat	16	
22	4751400	Washer, 1/4 Flat	8	
23	4751500	Washer, 5/16 Flat	1	
		<b>BATTERY BOX AND CHARGER INSTALLATIONS</b>	Ref.	
	0258203	<b>BATTERY BOX (12VDC ONLY)</b>	Ref.	E
	0258493	<b>BATTERY BOX (WET SPARE)</b>	Ref.	A
	0258498	<b>BATTERY BOX (DRY SPARE)</b>	Ref.	E
101	0400223	Battery Box and Charger Assy (Includes Items 1-23)	1	
102		Battery Options:	1	
	0400122	Standard Wet Battery		
	0400144	Standard Dry Battery		
	0270163	<b>BDI INSTALLATION</b>	1	C
201	2420195	Gauge, BDI	1	

**SECTION 2 CONTROLS**

# SECTION 2 CONTROLS

FIGURE 2-6. BATTERY CHARGER ASSEMBLY

NOTE: COVER NOT SHOWN FOR CLARITY

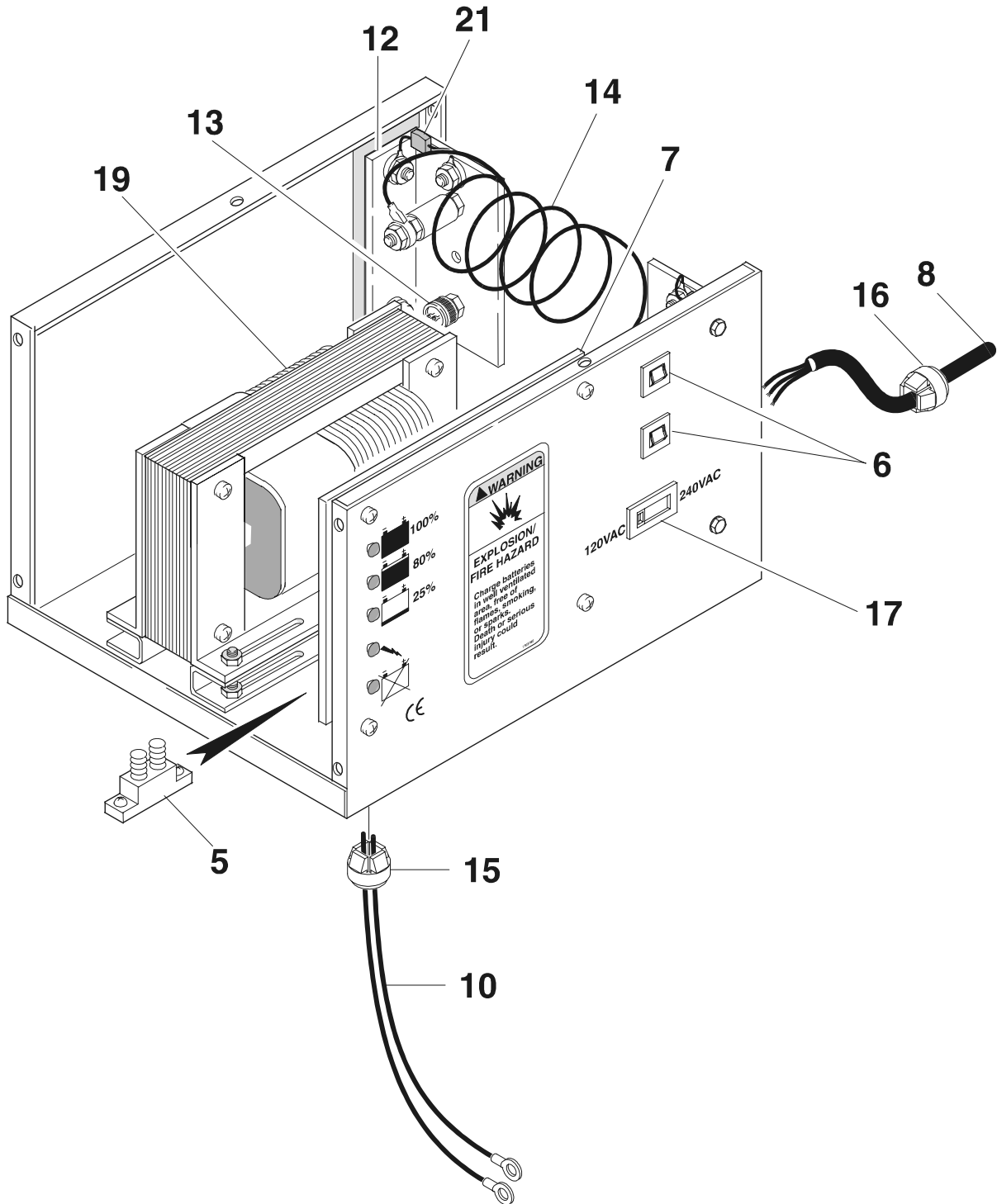

SECTION 2 CONTROLS

# SECTION 2 CONTROLS

**FIGURE 2-6. BATTERY CHARGER ASSEMBLY**

FIG & ITEM #	PART NUMBER	DESCRIPTION	QTY.	REV.
	0400176	<b>BATTERY CHARGER ASSEMBLY</b>	Ref.	F
1 to 4	Not Used			
5	7011509	Breaker, Circuit - DC 50Amp	1	
6	7018536	Breaker, Circuit 3 Amp	2	
7	7020626	Card, Circuit	1	
8	7020627	AC Cord Assembly	1	
9	Not Used			
10	7020629	DC Harness	1	
11	Not Used			
12	7020631	Rectifier Assembly	2	
13	7018555	SCR Rectifier	1	
14	7020605	Shunt Assembly	1	
15	7018556	Connector, Strain Relief - DC	1	
16	7011528	Connector, Strain Relief - AC	1	
17	7018586	Switch, Slide	1	
18	Not Used			
19	7020032	Transformer	1	
20	Not Used			
21	7020633	Varistor	1	

**SECTION 2 CONTROLS**

# SECTION 2 CONTROLS

FIGURE 2-7. DC MOTOR/PUMP ASSEMBLY

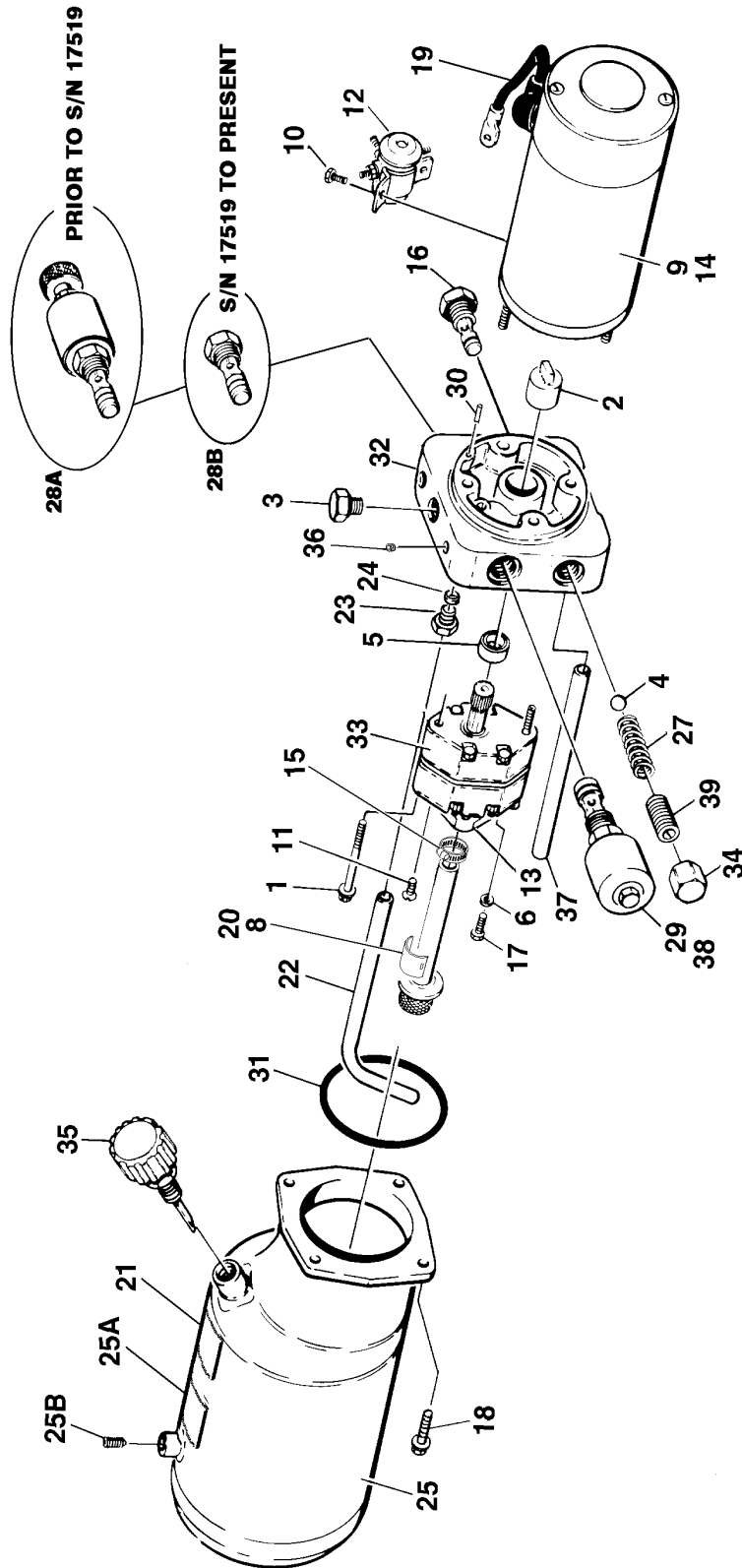

WFOH2002NOIHOES

# SECTION 2 CONTROLS

**FIGURE 2-7. DC MOTOR/PUMP ASSEMBLY**

FIG & ITEM #	PART NUMBER	DESCRIPTION	QTY.	REV.
		<b>DC MOTOR/PUMP ASSEMBLY OPTIONS:</b>	Ref.	
	3600273	Prior to S/N 17519	Ref.	C
	3600320	S/N 17519 to Present	Ref.	B
1	7013713	Bolt 5/16"-24NF x 2 3/4"	2	
2	7016735	Coupling	1	
3	7013714	Plug	1	
4	7013715	Ball	1	
5	7013716	Seal	1	
6	7013717	Washer	1	
7	Not Used			
8	7013722	Magnet	1	
9	7013710	Motor	1	
10		Screw Options:	2	
	7013754	Prior to S/N 17519		
	7013758	S/N 17519 to Present		
11	7013728	Screw	2	
12	7013760	Solenoid	1	
13	7016770	Cover	1	
14	Not Used			
15	7016771	Clamp	1	
16	7013708	Cartridge, Valve - Check	1	
17		Bolt 5/16"-18NC x 1" Options:	1	
	7016720	Prior to S/N 17519		
	3931516	S/N 17519 to Present		
18	7016721	Bolt #12-24NC x 1/2"	4	
19	7016772	Cable	1	
20	Not Used			
21	7016713	Decal - Fill Line	1	
22	7013795	Tube, Return	1	
23	7013792	Nut, Tube Compression	1	
24	7013793	Sleeve, Tube Compression	1	
25	7016775	Tank	1	
25A	7016776	Decal - Caution	1	
25B	7016759	Plug	1	
26	7016773	Plumbing Assembly - Inlet	1	
27	7013733	Spring	1	
28		Cartridge, Valve Options:	1	
28A	7013764	Cartridge, Manual Descent (Prior to S/N 17519)		
28B	7022204	Cartridge (S/N 17519 to Present)		
29	7016751	Cartridge, Valve - Solenoid	1	
30	7013766	Pin	1	
31	7013743	O-Ring	1	
32	7016753	End Head	1	
33	7013747	Pump Assembly	1	
34	7013779	Cap, Relief	1	
35	7016714	Breather	1	
36	7013720	Plug	2	

**SECTION 2 CONTROLS**

# SECTION 2 CONTROLS

FIGURE 2-7. DC MOTOR/PUMP ASSEMBLY

FIG & ITEM #	PART NUMBER	DESCRIPTION	QTY.	REV.
37	7013768	Tube, Return Options: Prior to S/N 17519 S/N 17519 to Present	1	
38	7016755	Valve	1	
39	7013770	Screw, Adjustment	1	

SECTION 2 CONTROLS

# SECTION 2 CONTROLS

FIGURE 2-7. DC MOTOR/PUMP ASSEMBLY

FIG & ITEM #	PART NUMBER	DESCRIPTION	QTY.	REV.

**S  
E  
C  
T  
I  
O  
N  
  
2  
  
C  
O  
N  
T  
R  
O  
L  
S**

# SECTION 2 CONTROLS

FIGURE 2-8. CABLES AND CONTROLS INSTALLATION

SECTION 2 CONTROLS

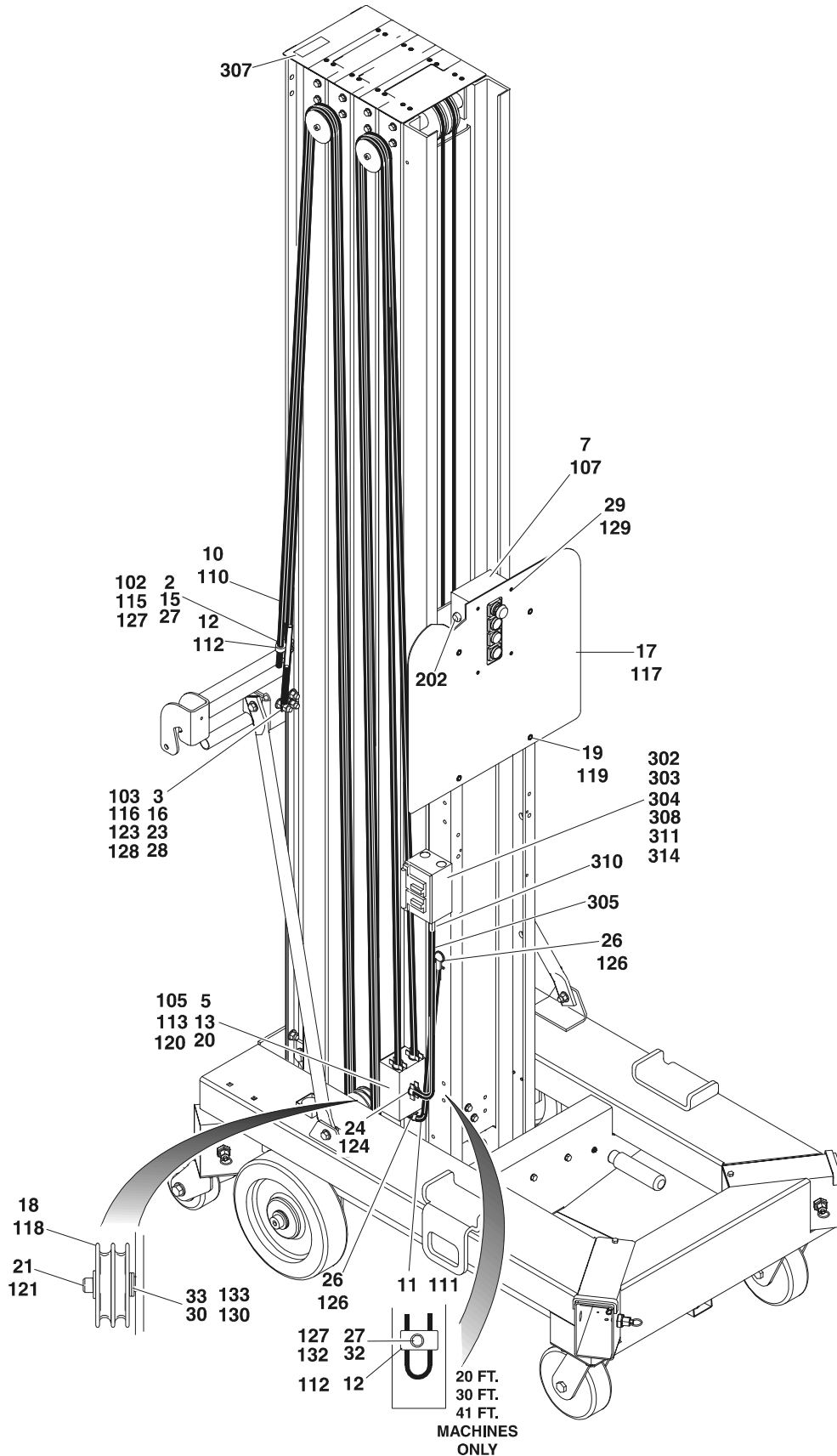



# SECTION 2 CONTROLS

**FIGURE 2-8. CABLES AND CONTROLS INSTALLATION**

FIG & ITEM #	PART NUMBER	DESCRIPTION	QTY.	REV.
		<b>CABLES AND CONTROLS INSTALLATIONS</b>	Ref.	
	0258449	<b>20EL (DC Machines)</b>	Ref.	D
	0258591	<b>20EL (AC Machines)</b>	Ref.	E
1	0100011	Loctite #242 (Not Shown)	A/R	
2	0641410	Bolt 1/4"-20NC x 1 1/4"	2	
3	0641612	Bolt 3/8"-16NC x 1 1/2"	1	
4	Not Used			
5	Not Required	Box, Junction	0	
6	Not Used			
7	0861207	Control Box Assembly:	1	
	7020078	Switch, Push-Pull (Red)	1	
	7020088	Switch, Push Button (White)	2	
	7020089	Switch, Push Button (Green)	1	
	7020091	Plug	1	
	Use 7027299	Connector, Strain Relief (was p/n 7020092)	1	
	7020093	Screw m3 x 25 Freedrive	4	
8	Not Used			
9	Not Required	Cable, Retractable - 16/4	0	
10		Harness, AC Control Cable Options:		
	4922657	DC Machines	Ref.	A
	1060687	Cable, Electrical - 16/5	25.3ft/7.4m	
	4460115	Terminal, Fork 16 GA (Not Shown)	4	
	4923070	AC Machines	Ref.	A
	1060687	Cable, Electrical - 16/5	26.5ft/8.1m	
	4460115	Terminal, Fork 16 GA (Not Shown)	3	
	4460145	Terminal, Fork (Not Shown)	3	
11	Not Required	Cable, Retractable - 16/5	0	
12		Clamp Options:	2	
	1320238	(Prior to S/N 078743)		
	1320149	(S/N 078743 to Present)		
13	Not Required	Cover, Junction Box	0	
14	Not Used			
15	3311405	Locknut 1/4"-20NC	1	
16	3311605	Locknut 3/8"-16NC	2	
17	3570923	Plate, Decal Mounting	1	
18	3580231	Sheave, Control Cable	A/R	
19	3820032	Rivet	4	
20	3900191	Screw	A/R	
21	3900200	Screw, Shoulder	A/R	
22	4060092	Shield, Weatherproof Receptacle Cover (AC Machines Only)	1	
23	4160130	Spring, Extension	1	
24	Not Used			
25	4460190	Receptacle, Electrical (AC Machines Only)	1	
26	4460566	Connector, Strain Relief - 90°	A/R	
27	4711400	Flatwasher 1/4" Narrow	A/R	
28	4711600	Flatwasher 3/8" Narrow	2	
29	4740426	Washer #8 (Prior to S/N 17519 Only)	4	

**SECTION 2 CONTROLS**

# SECTION 2 CONTROLS

**FIGURE 2-8. CABLES AND CONTROLS INSTALLATION (CONTINUED)**

FIG & ITEM #	PART NUMBER	DESCRIPTION	QTY.	REV.
30	4751500	Flatwasher 5/16"	A/R	
31	Not Used			
32	0641416	Bolt 1/4-20NC x 2	A/R	
33	4751000	Flatwasher #10 Wide (S/N 078743 to Present)	A/R	
34	4460115	Terminal, Fork 16 GA (S/N 17519 to S/N 22888) (Not Shown)	1	
35	4922420	Harness, Jumper (Control Box) (S/N 17519 to Present) (Not Shown)	1	
36	4460145	Terminal, Fork (S/N 17519 to S/N 22888) (Not Shown - AC Machines Only)	4	
		<b>CABLES AND CONTROLS INSTALLATIONS</b>	Ref.	
	0258450	<b>25EL (DC Machines)</b>	Ref.	D
	0258592	<b>25EL (AC Machines)</b>	Ref.	E
	0258451	<b>30EL (DC Machines)</b>	Ref.	D
	0258593	<b>30EL (AC Machines)</b>	Ref.	E
	0258452	<b>36EL (DC Machines)</b>	Ref.	D
	0258594	<b>36EL (AC Machines)</b>	Ref.	E
	0258453	<b>41EL (DC Machines)</b>	Ref.	D
	0258595	<b>41EL (AC Machines)</b>	Ref.	E
101	0100011	Loctite #242 (Not Shown)	A/R	
102	0641410	Bolt 1/4"-20NC x 1 1/4"	2	
103	0641612	Bolt 3/8"-16NC x 1 1/2"	1	
104	Not Used			
105		Box, Junction Options:	A/R	
	Not Required	DC Machines	0	
	0860945	25EL/36EL (AC Models)	1	
	Not Required	30EL/41EL (AC Models)	0	
106	Not Used			
107	0861207	Control Box Assembly:	1	
	7020078	Switch, Push-Pull (Red)	1	
	7020088	Switch, Push Button (White)	2	
	7020089	Switch, Push Button (Green)	1	
	7020091	Plug	1	
	Use 7027299	Connector, Strain Relief (was p/n 7020092)	1	
	7020093	Screw m3 x 25 Freedrive	4	
108 to 109	Not Used			
110		Harness, Control Options:		
	4923075	25EL (DC Machines) (S/N 22888 to Present)	Ref.	
	4923076	25EL (AC Machines) (S/N 22888 to Present)	A/R	
	4923081	30EL (DC Machines) (S/N 22916 to Present)	A/R	
	4923082	30EL (AC Machines) (S/N 22916 to Present)	A/R	
	4923087	36EL (DC Machines) (S/N 22916 to Present)	A/R	
	4923088	36EL (AC Machines) (S/N 22916 to Present)	A/R	
	4923093	41EL (DC Machines) (S/N 22916 to Present)	A/R	
	4923094	41EL (AC Machines) (S/N 22916 to Present)	A/R	
	1060687	Cable, Electrical - 16/5 Options:	A/R	
		25EL (DC Machines)	20.3ft/6.2m	
		25EL (AC Machines)	20.8ft/6.4m	

SECTION 2 CONTROLS

# SECTION 2 CONTROLS

**FIGURE 2-8. CABLES AND CONTROLS INSTALLATION (CONTINUED)**

FIG & ITEM #	PART NUMBER	DESCRIPTION	QTY.	REV.
		30EL (DC Machines)	36.5ft/11.1m	
		30EL (AC Machines)	37.5ft/11.4m	
		36EL (DC Machines)	29ft/8.8m	
		36EL (AC Machines)	30.3ft/9.24m	
		41EL (DC Machines)	49.5ft/15.1m	
		41EL (AC Machines)	50.5ft/15.4m	
	4460035	Terminal, Butt Splice (Not Shown - 25EL/36EL Only)	5	
	4460145	Terminal, Fork (Not Shown - AC Models Only)	3	
	4460115	Terminal, Fork 16GA (Not Shown - 30EL/41EL Only)	5	
111		Cable, Retractable - 16/5 Options:	A/R	
	1060694	25EL/36EL (AC/DC Machines)	6in/15cm	
	Not Required	30EL/41EL (AC/DC Machines)	0	
112	1320238	Clamp (Prior to S/N 078743)	A/R	
	1320149	Clamp (S/N 078743 to Present)	A/R	
113		Cover, Junction Box Options	A/R	
	1670603	25EL/36EL (AC/DC Machines)	1	
	Not Required	30EL/41EL (AC/DC Machines)	0	
114	Not Used			
115	3311405	Locknut 1/4"-20NC	1	
116	3311605	Locknut 3/8"-16NC	2	
117	3570923	Plate, Decal Mounting	1	
118	3580231	Sheave, Control Cable	A/R	
119	3820032	Rivet	4	
120	3900191	Screw 25EL/36EL (AC/DC Machines)	A/R	
121	3900200	Screw, Shoulder	A/R	
122	4060092	Shield, Weatherproof Receptacle Cover (Prior to S/N 17519) (AC Models Only)	1	
123	4160130	Spring, Extension	1	
124	4460023	Connector, Strain Relief (25EL/36EL) (DC Models Only)	A/R	
125	4460190	Receptacle, Electrical (Prior to S/N 17519) (AC Models Only)	1	
126	4460566	Connector, Strain Relief - 90°	A/R	
127	4711400	Flatwasher 1/4" Narrow	A/R	
128	4711600	Flatwasher 3/8" Narrow	2	
129	4740426	Washer #8 (Prior to S/N 17519) (AC Models Only)	4	
130	4751500	Flatwasher 5/16"	A/R	
131 to 132	Not Used			
133	4751000	Flatwasher #10 Wide (S/N 078743 to Present)	A/R	
134	4460115	Terminal, Fork 16GA (S/N 17519 to S/N 22888) (Not Shown)	5	
135	4922420	Harness, Jumper Control Box (S/N 17519 to Present) (Not Shown)	1	
136	3520034	Plug, 5/16 Hole (S/N 17519 to Present) (25EL/36EL) (Not Shown)	2	
137	4460035	Terminal, Butt Splice (S/N 17519 to S/N 22888) (25EL/36EL) (Not Shown)	5	
138	4460145	Terminal, Fork (Not Shown - AC Models Only) (Prior to S/N 22888)	4	

**SECTION 2 CONTROLS**

# SECTION 2 CONTROLS

**FIGURE 2-8. CABLES AND CONTROLS INSTALLATION (CONTINUED)**

FIG & ITEM #	PART NUMBER	DESCRIPTION	QTY.	REV.
	0258482	<b>AUXILIARY LOWERING INSTALLATION</b>	Ref.	A
201	Not Used			
202	4360274	Switch, Push Button	1	
203 to 204	Not Used			
		<b>ACCESSORY OUTLET INSTALLATIONS</b>	Ref.	
	0270748	(20EL) 120V (DC)	Ref.	B
	0270749	(20EL) 240V (DC)	Ref.	B
	0270975	(20EL) 120V (AC)	Ref.	B
	0270976	(20EL) 240V (AC)	Ref.	B
	0270773	(25EL) 120V (DC)	Ref.	B
	0270774	(25EL) 240V (DC)	Ref.	B
	0270978	(25EL) 120V (AC)	Ref.	B
	0270979	(25EL) 240V (AC)	Ref.	B
	0270776	(30EL) 120V (DC)	Ref.	B
	0270777	(30EL) 240V (DC)	Ref.	B
	0270981	(30EL) 120V (AC)	Ref.	B
	0270982	(30EL) 240V (AC)	Ref.	B
	0270779	(36EL) 120V (DC)	Ref.	B
	0270780	(36EL) 240V (DC)	Ref.	B
	0270984	(36EL) 120V (AC)	Ref.	B
	0270985	(36EL) 240V (AC)	Ref.	B
	0270782	(41EL) 120V (DC)	Ref.	B
	0270783	(41EL) 240V (DC)	Ref.	B
	0270987	(41EL) 120V (AC)	Ref.	B
	0270988	(41EL) 240V (AC)	Ref.	B
301	0100011	Loctite #242 (Not Shown)	A/R	
302		Bolt Options:		
	0641418	1/4" - 20NC x 2 1/4" (20EL/30EL/41EL)	1	
	Not Required	(25EL/36EL)		
303	0721006	Bolt #10-24NC x 3/4"	2	
304	0840946	Box, Receptacle	1	
305		Cable, Electrical Options:		
	1060925	12/3 (20EL DC Only)	21.7ft/6.6m	
	4923069	20EL - AC (S/N 22888 to Present)	Ref.	A
	4923071	25EL - DC (S/N 22888 to Present)	Ref.	A
	4923073	25EL - AC (S/N 22888 to Present)	Ref.	A
	4923077	30EL - DC (S/N 22916 to Present)	Ref.	A
	4923079	30EL - AC (S/N 22916 to Present)	Ref.	A
	4923083	36EL - DC (S/N 22916 to Present)	Ref.	A
	4923085	36EL - AC (S/N 22916 to Present)	Ref.	A
	4923089	41EL - DC (S/N 22916 to Present)	Ref.	A
	4923091	41EL - DC (S/N 22916 to Present)	Ref.	A
	1060564	12/3 Electrical Cable	A/R	
	4460018	Butt Splice, Terminal (20EL - DC/25EL - AC/36EL - DC/36EL - AC)	3	
	4460315	Terminal, Fork (20EL - AC/25EL - AC/30EL - DC/30EL - AC/36EL - AC/41EL - DC/41EL - AC)	A/R	

SECTION 2 CONTROLS

# SECTION 2 CONTROLS

**FIGURE 2-8. CABLES AND CONTROLS INSTALLATION (CONTINUED)**

FIG & ITEM #	PART NUMBER	DESCRIPTION	QTY.	REV.
306	1060565	16/4 (Retractable) (25EL/36EL)	.5ft/.15m	
		Clamp, Hose Options:		
307	1320149	(20EL/30EL/41EL) (Not Shown)	1	
	Not Required	(25EL/36EL)	0	
308		Decal Options:	2	
	3252761	120 Volt		
	3252760	240 Volt		
309	3311001	Nut #10-24NC	2	
310		Shield, Weatherproof Receptacle Cover Options:		
	4060092	120 Volt	1	
311	Not Required	240 Volt	0	
	4460023	Connector, Strain Relief	A/R	
312		Terminal, Fork Options: (Prior to S/N 22916)		
	4460145	120 Volt	A/R	
	4460145	240 Volt (AC Only)	A/R	
313		Receptacle, Electrical Options:		
	4460190	120 Volt	1	
314	Not Required	240 Volt	0	
	4460549	Plug, Terminal 115 Volt Options:		
315	Not Required	120 Volt (DC Only) (Not Shown)	1	
	4761000	240 Volt	0	
316		Lockwasher #10	A/R	
		Wire Cap, Terminal Options:		
	Not Required	120 Volt	0	
317	4460121	240 Volt (AC Only) (Not Shown)	3	
		Butt Splice, Terminal Options: (Prior to S/N 22916)		
318	4460035	(25EL/36EL) (Not Shown)	3	
	Not Required	(20EL/30EL/41EL)	0	
319		Tie Wire Options:		
	4240033	(25EL/36EL) (Not Shown)	1	
	Not Required	(20EL/30EL/41EL)	0	

**SECTION 2 CONTROLS**

# SECTION 2 CONTROLS

FIGURE 2-8. CABLES AND CONTROLS INSTALLATION (CONTINUED)

**S  
E  
C  
T  
I  
O  
N  
2  
C  
O  
N  
T  
R  
O  
L  
S**

FIG & ITEM #	PART NUMBER	DESCRIPTION	QTY.	REV.

# SECTION 3 MAST

## TABLE OF CONTENTS

FIGURE	DESCRIPTION	PAGE
3-1	MAST ASSEMBLY - 20EL .....	3-2
3-2	MAST ASSEMBLY - 25EL/36EL .....	3-6
3-3	MAST ASSEMBLY - 30EL/41EL .....	3-10
3-4	MAST MOUNTING COMPONENTS .....	3-16

**S  
E  
C  
T  
I  
O  
N  
  
3  
  
M  
A  
S  
T**

# SECTION 3 MAST

FIGURE 3-1. MAST ASSEMBLY - 20EL

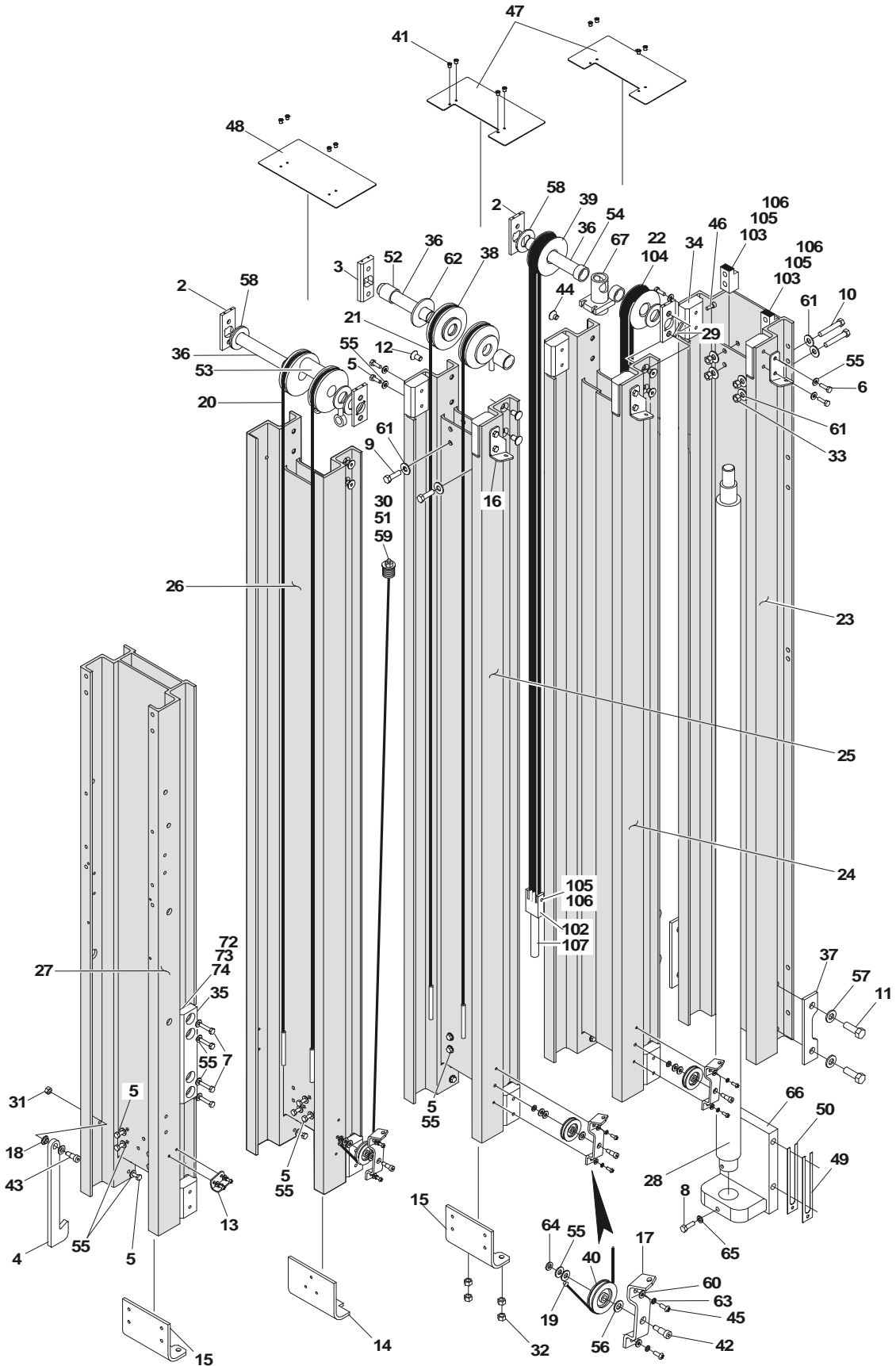

SECTION 3 MAST



# SECTION 3 MAST

**FIGURE 3-1. MAST ASSEMBLY - 20EL**

FIG & ITEM #	PART NUMBER	DESCRIPTION	QTY.	REV.
		<b>MAST ASSEMBLY - 20EL OPTIONS:</b>	Ref.	
	0801141	(Prior to S/N 17519)	Ref.	H
	0801291	(S/N 17519 to Present)	Ref.	C
1	0100011	Loctite #242 (Not Shown)	A/R	
2	0362735	Bar, Sheave Pin Support	4	
3	0362736	Bar, Sheave Pin Support	2	
4	0362758	Bar, Gravity Latch	1	
5	0641406	Bolt 1/4"-20NC x 3/4"	33	
6	0641407	Bolt 1/4"-20NC x 7/8"	6	
7		Bolt Options:	A/R	
	0641410	Bolt 1/4"-20NC x 1 1/4" (Prior to S/N 15661)	4	
	0681410	Bolt 1/4"-20NC x 1 1/4" (S/N 15661 to Present)	8	
8	0641508	Bolt 5/16"-18NC x 1"	1	
9	0641610	Bolt 3/8"-16NC x 1 1/4"	2	
10	0641618	Bolt 3/8"-16NC x 2 1/4"	4	
11	0641812	Bolt 1/2"-13NC x 1 1/2"	4	
12	0741606	Screw 3/8"-16NC x 3/4"	4	
13	0902047	Bracket, Sequence Cable	1	
14	0902423	Bracket, Bottom Chain Attach	1	
15	0902424	Bracket, Bottom Chain Attach	2	
16	0902431	Bracket, Sequence Cable	3	
17	0902445	Bracket, Sequence Cable	3	
18	0961892	Bushing, Flanged	2	
19	1060683	Cable, Sequence	3	
20	1060685	Cable, Extension	2	
21	1060696	Cable, Extension	2	
22	1260329	Chain Assembly - #466 (See Items 101-107 for Breakdown)	2	
23	1271389	Channel, Mast #1	1	
24	1271390	Channel, Mast #2	1	
25	1271391	Channel, Mast #3	1	
26	1271392	Channel, Mast #6	1	
27	1271393	Channel, Mast Header	1	
28		Lift Cylinder Assembly Options (See Section 5 for Breakdown):	1	
	1683699	(Prior to S/N 17519)		
	1684088	(S/N 17519 to Present)		
29	2880310	Key	3	
30	3311405	Locknut 1/4"-20NC (Prior to S/N 12269)	3	
	3311401	Nut 1/4"-20NC (S/N 12269 to Present)	3	
31	3311505	Locknut 5/16"-18NC	1	
32	3311601	Nut 3/8"-16 NC	12	
33	3311605	Locknut 3/8"-16NC	6	
34	3340845	Pad, Slide Guide	14	
35		Pad, Slide Guide Options:	2	
	Use 3340858	Prior to S/N 15661 (P/N was 3340846)		
	3340858	S/N 15661 to Present		
36	3422717	Pin, Sheave	3	
37	3570893	Plate, Cylinder Mount	2	

SECTION 3 MAST

# SECTION 3 MAST

**FIGURE 3-1. MAST ASSEMBLY - 20EL (CONTINUED)**

FIG & ITEM #	PART NUMBER	DESCRIPTION	QTY.	REV.
38	3580217	Sheave, Cable	4	
39		Sheave Assembly Options:	2	
	3580268	Prior to S/N 17519		
	3580286	S/N 17519 to Present		
40	3580269	Sheave, Sequence Cable	3	
41	3820006	Rivet (Prior to S/N 12269)	12	
	3820034	Rivet (S/N 12269 to Present)	12	
42	3900187	Screw, Shoulder	3	
43	3900190	Screw, Shoulder	1	
44	3900192	Screw, Countersunk 3/8"-16NC x 1/2"	8	
45	3900205	Screw, #10-24NC x 1/2"	8	
46	3900206	Bolt 1/4"-28NF x 3/8"	1	
47	4060960	Shield, Mast Cover	2	
48	4060961	Shield, Mast Cover	1	
49	4070970	Shim, Cylinder Mount	2	
50	4070971	Shim, Cylinder Mount	4	
51	4160124	Spring	3	
52	4567489	Tube, Spacer	2	
53	4567492	Tube, Spacer	1	
54	4567635	Tube, Spacer	2	
55	4711400	Flatwasher 1/4" Narrow	53	
56	4711500	Flatwasher 5/16" Narrow	3	
57	4711800	Flatwasher 1/2" Narrow	4	
58		Washer Options:	9	
	4712600	Flatwasher 1" Narrow (Prior to S/N 17519)		
	4740007	Thrust Washer (S/N 17519 to Present)		
59	4740414	Cupwasher	6	
60	4750800	Flatwasher #8 Wide	8	
61	4751600	Flatwasher 3/8" Wide	12	
62	4752600	Flatwasher 1" Wide	2	
63	4761000	Lockwasher #10	8	
64	4761400	Lockwasher 1/4"	3	
65	4761500	Lockwasher 5/16"	1	
66		Weld, Cylinder Mount Options:	1	
	4845731	(Prior to S/N 17519)		
	4846381	(S/N 17519 to S/N 19294)		
	4846514	(S/N 19294 to Present)		
67	4845795	Weld, Cylinder Cable Mount	1	
68	4070860	Shim, Slide Pad (.075)	14	
69	4070861	Shim, Slide Pad (.036)	14	
70	4070862	Shim, Slide Pad (.015)	10	
71	Not Used			
72	4070988	Shim, Slide Pad (.075) (S/N 15661 to Present)	2	
73	4070989	Shim, Slide Pad (.036) (S/N 15661 to Present)	2	
74	4070990	Shim, Slide Pad (.015) (S/N 15661 to Present)	2	
	2901603	Mast Kit (Includes Items 23 - 27)	1	

**SECTION 3 MAST**

# SECTION 3 MAST

**FIGURE 3-1. MAST ASSEMBLY - 20EL (CONTINUED)**

FIG & ITEM #	PART NUMBER	DESCRIPTION	QTY.	REV.
	1260329	<b>CHAIN ASSEMBLY - #466 CHAIN</b>	Ref.	C
101	0100062	Loctite #RC/640 (Not Shown)	A/R	
102		Block Options:	1	
	0561150	Prior to S/N 15061		
	0561409	S/N 15061 to Present		
103	0561306	Block	1	
104	1260299	Chain	71in/1.8m	
105	3422265	Pin	2	
106	3450201	Pin, Cotter	4	
107	4300111	Stud	1	

SECTION 3 MAST

# SECTION 3 MAST

FIGURE 3-2. MAST ASSEMBLY - 25EL & 36EL

SECTION 3 MAST

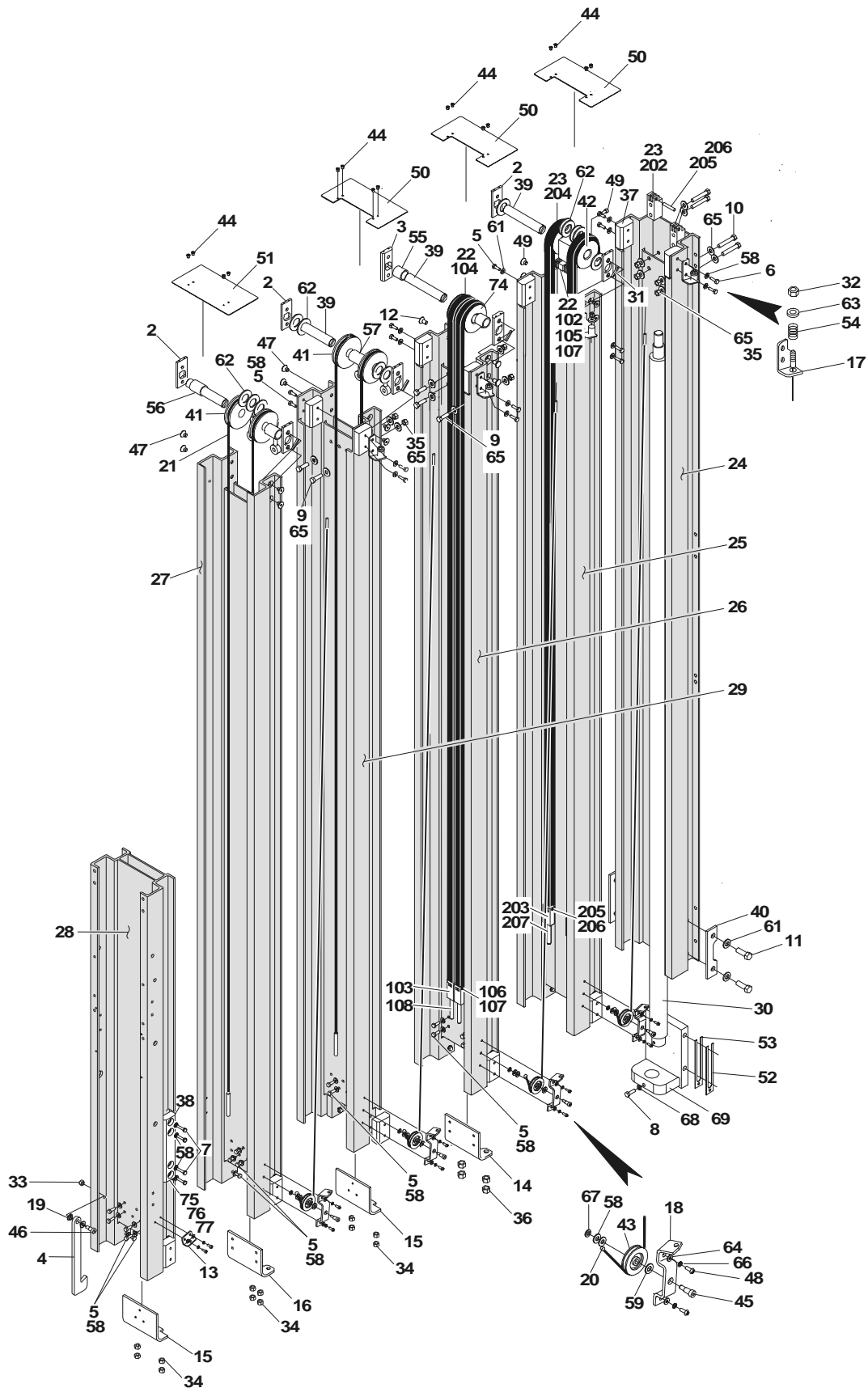

# SECTION 3 MAST

**FIGURE 3-2. MAST ASSEMBLY - 25EL & 36EL**

FIG & ITEM #	PART NUMBER	DESCRIPTION	QTY.	REV.
		<b>MAST ASSEMBLIES OPTIONS:</b>	Ref.	
	0801142	<b>25EL (Prior to S/N 17519)</b>	Ref.	G
	0801292	<b>25EL (S/N 17519 to Present)</b>	Ref.	C
	0801144	<b>36EL (Prior to S/N 17519)</b>	Ref.	G
	0801294	<b>36EL (S/N 17519 to Present)</b>	Ref.	C
1	0100011	Loctite #242 (Not Shown)	A/R	
2	0362735	Bar, Sheave Pin Support	6	
3	0362736	Bar, Sheave Pin Support	2	
4	0362758	Bar, Gravity Latch	1	
5	0641406	Bolt 1/4"-20NC x 3/4"	42	
6	0641407	Bolt 1/4"-20NC x 7/8"	8	
7		Bolt Options:	A/R	
	0641410	Bolt 1/4"-20NC x 1 1/4" (Prior to S/N 15661)	4	
	0681410	Bolt 1/4"-20NC x 1 1/4" (S/N 15661 to Present)	8	
8	0641508	Bolt 5/16"-18NC x 1"	1	
9	0641610	Bolt 3/8"-16NC x 1 1/4"	4	
10	0641618	Bolt 3/8"-16NC x 2 1/4"	4	
11	0641812	Bolt 1/2"-13NC x 1 1/2"	4	
12	0741606	Screw 3/8"-16NC x 3/4"	4	
13	0902047	Bracket, Sequence Cable	1	
14	0902422	Bracket, Bottom Chain Attach	1	
15	0902423	Bracket, Bottom Chain Attach	2	
16	0902424	Bracket, Bottom Chain Attach	1	
17	0902431	Bracket, Sequence Cable	4	
18	0902445	Bracket, Sequence Cable	4	
19	0961892	Bushing, Flanged	2	
20		Cable, Sequence Options:	4	
	1060683	25EL		
	1060684	36EL		
21		Cable, Extension Options:	4	
	1060685	25EL		
	1060655	36EL		
22		Chain Assembly Options:	1	
	1260331	25EL		
	1260332	36EL		
23		Chain Assembly Options:	2	
	1260333	25EL		
	1260334	36EL		
24		Channel, Mast #1 Options:	1	
	1271389	25EL		
	1271394	36EL		
25		Channel, Mast #2 Options:	1	
	1271390	25EL		
	1271395	36EL		
26		Channel, Mast #3 Options:	1	
	1271391	25EL		
	1271396	36EL		

SECTION 3 MAST

# SECTION 3 MAST

**FIGURE 3-2. MAST ASSEMBLY - 25EL & 36EL (CONTINUED)**

FIG & ITEM #	PART NUMBER	DESCRIPTION	QTY.	REV.
27		Channel, Mast #6 Options:	1	
	1271392	25EL		
	1271398	36EL		
28	1271393	Channel, Mast Header	1	
29		Channel, Mast #4 Options:	1	
	1271399	25EL		
	1271397	36EL		
30		Cylinder Assembly Options: (See Section 5 for Breakdown)	1	
	1683699	25EL (Prior to S/N 17519)		
	1684088	25EL (S/N 17519 to Present)		
	1683693	36EL (Prior to S/N 17519)		
	1684087	36EL (S/N 17519 to Present)		
31	2880310	Key	4	
32	3311405	Locknut 1/4-20NC (Prior to S/N 12269)	4	
	3311401	Nut 1/4-20NC (S/N 12269 to Present)	4	
33	3311505	Locknut 5/16-18NC	1	
34	3311601	Nut 3/8-16NC	12	
35	3311605	Locknut 3/8-16N	8	
36	3311801	Nut 1/2-13NC	4	
37	3340845	Pad, Slide Lock	18	
38		Pad, Slide Guide Options:	2	
	Use 3340858	Prior to S/N 15661 (P/N was 3340846)		
	3340858	S/N 15661 to Present		
39	3422717	Pin, Sheave	4	
40	3570893	Plate, Cylinder Mount	2	
41	3580217	Sheave, Cable	4	
42		Sheave Assembly Options:	2	
	3580268	Prior to S/N 17519		
	3580286	S/N 17519 to Present		
43	3580269	Sheave, Sequence Cable	4	
44	3820006	Rivet, 1/4" x 1/2" (Prior to S/N 12269)	16	
	3820034	Rivet, 1/4" x .390" (S/N 12269 to Present)	16	
45	3900187	Screw, Shoulder	4	
46	3900190	Screw, Shoulder	1	
47	3900192	Screw, Countersunk 3/8"-16NC x 1/2"	12	
48	3900205	Screw, #10-24NC x 1/2"	10	
49	3900206	Bolt, 1/4"28NF x 5/8"	1	
50	4060960	Shield, Mast Cover	3	
51	4060961	Shield, Mast Cover	1	
52	4070970	Shim, Cylinder Mount	2	
53	4070971	Shim, Cylinder Mount	4	
54	4160124	Spring	4	
55	4567489	Tube, Spacer	2	
56	4567491	Tube, Spacer	2	
57	4567492	Tube, Spacer	1	
58	4711400	Flatwasher, 1/4" Narrow	66	
59	4711500	Flatwasher, 5/16" Narrow	4	
60	4711600	Flatwasher, 3/8" Narrow	2	
61	4711800	Flatwasher, 1/2" Narrow	4	

**SECTION 3 MAST**

# SECTION 3 MAST

**FIGURE 3-2. MAST ASSEMBLY - 25EL & 36EL (CONTINUED)**

FIG & ITEM #	PART NUMBER	DESCRIPTION	QTY.	REV.
62	4712600	Flatwasher, 1" Narrow	14	
63	4740414	Cup Washer	8	
64	4750800	Flatwasher, 8" Wide	10	
65	4751600	Flatwasher, 3/8" Wide	14	
66	4761000	Lockwasher, #10	10	
67	4761400	Lockwasher, 1/4"	4	
68	4761500	Lockwasher, 5/16"	1	
69		Weld, Cylinder Mount Options:	1	
	4845731	(Prior to S/N 17519)		
	4846381	(S/N 17519 to S/N 19294)		
	4846514	(S/N 19294 to Present)		
70	4070860	Shim, Slide Pad (.075)	18	
71	4070861	Shim, Slide Pad (.036)	18	
72	4070862	Shim, Slide Pad (.015)	14	
73	Not Used			
74	3580272	Sheave, Assembly (S/N 12354 to Present)	2	
75	4070988	Shim, Slide Pad (.075)	2	
76	4070989	Shim, Slide Pad (.036)	2	
77	4070990	Shim, Slide Pad (.015)	2	
		-----		
		Mast Kit Options:	1	
	2901604	25 EL (Includes Items 24 - 29)		
	2901606	36 EL (Includes Items 24 - 29)		
	1260331	<b>CHAIN ASSEMBLY - #534 CHAIN - 25EL</b>	Ref.	C
	1260332	<b>CHAIN ASSEMBLY - #534 CHAIN - 36EL</b>	Ref.	C
101	0100062	Loctite #RC/640 (Not Shown)	A/R	
102	0561307	Block	1	
103	0561309	Block	2	
104	Purchase Assy	Chain		
105	3422721	Pin	1	
106	3422722	Pin	2	
107	3450202	Pin, Cotter	4	
108	4300111	Stud	2	
	1260333	<b>CHAIN ASSEMBLY - #544 CHAIN - 25EL</b>	Ref.	B
	1260334	<b>CHAIN ASSEMBLY - #544 CHAIN - 36EL</b>	Ref.	B
201	0100062	Loctite #RC/640 (Not Shown)	A/R	
202	0561305	Block	1	
203	0561308	Block	2	
204	Purchase Assy	Chain		
205	3422720	Pin	2	
206	3450202	Pin, Cotter	4	
207	4300129	Stud	1	

SECTION 3 MAST

# SECTION 3 MAST

FIGURE 3-3. MAST ASSEMBLY - 30EL & 41EL

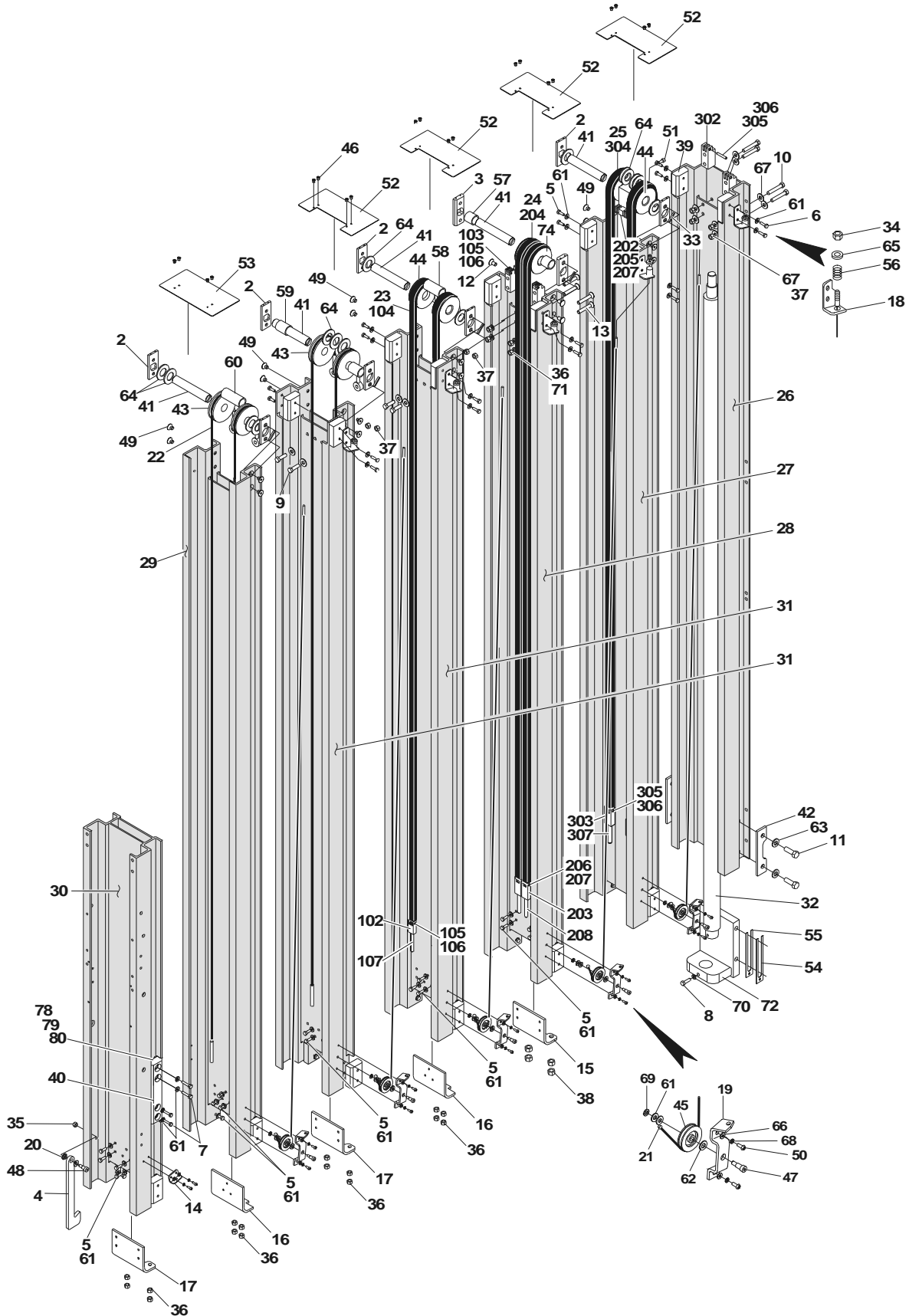

SECTION 3 MAST



# SECTION 3 MAST

**FIGURE 3-3. MAST ASSEMBLY - 30EL & 41EL**

FIG & ITEM #	PART NUMBER	DESCRIPTION	QTY.	REV.
		<b>MAST ASSEMBLIES OPTIONS:</b>	Ref.	
	0801143	<b>30EL (Prior to S/N 17519)</b>	Ref.	G
	0801293	<b>30EL (S/N 17519 to Present)</b>	Ref.	C
	0801145	<b>41EL (Prior to S/N 17519)</b>	Ref.	G
	0801295	<b>41EL (S/N 17519 to Present)</b>	Ref.	C
1	0100011	Loctite #242 (Not Shown)	A/R	
2	0362735	Bar, Sheave Pin Support	8	
3	0362736	Bar, Sheave Pin Support	2	
4	0362758	Bar, Gravity Latch	1	
5	0641406	Bolt 1/4"-20NC x 3/4"	52	
6	0641407	Bolt 1/4"-20NC x 7/8"	10	
7		Bolt Options:	A/R	
	0641410	Bolt 1/4"-20NC x 1 1/4" (Prior to S/N 15661)	4	
	0681410	Bolt 1/4"-20NC x 1 1/4" (S/N 15661 to Present)	8	
8	0641508	Bolt 5/16"-18NC x 1"	1	
9	0641610	Bolt 3/8"-16NC x 1 1/4"	4	
10	0641618	Bolt 3/8"-16NC x 2 1/4"	4	
11	0641812	Bolt 1/2"-13NC x 1 1/2"	4	
12	0741606	Screw 3/8"-16NC x 3/4"	4	
13	0741618	Screw, 3/8"-16NC x 2 1/4"	4	
14	0902047	Bracket, Sequence Cable	1	
15	0902422	Bracket, Bottom Chain Attach	1	
16	0902423	Bracket, Bottom Chain Attach	2	
17	0902424	Bracket, Bottom Chain Attach	2	
18	0902431	Bracket, Sequence Cable	5	
19	0902445	Bracket, Sequence Cable	5	
20	0961892	Bushing, Flanged	2	
21		Cable, Sequence Options:	5	
	1060683	30EL		
	1060684	41EL		
22		Cable, Extension Options:	4	
	1060685	30EL		
	1060548	41EL (Prior to S/N 12269)		
	1060655	41EL (S/N 12269 to Present)		
23		Chain Assembly Options:	2	
	1260329	30EL		
	1260330	41EL		
24		Chain Assembly Options:	1	
	1260331	30EL		
	1260332	41EL		
25		Chain Assembly Options:	2	
	1260333	30EL		
	1260334	41EL		
26		Channel, Mast #1	1	
	1271389	30EL		
	1271394	41EL		
27		Channel, Mast #2 Options:	1	
	1271390	30EL		

SECTION 3 MAST

# SECTION 3 MAST

**FIGURE 3-3. MAST ASSEMBLY - 30EL & 41EL (CONTINUED)**

FIG & ITEM #	PART NUMBER	DESCRIPTION	QTY.	REV.
28	1271395	41EL	1	
		Channel, Mast #3 Options:		
29	1271391	30EL	1	
	1271396	41EL		
		Channel, Mast #6 Options:		
30	1271392	30EL	1	
	1271398	41EL		
31	1271393	Channel, Mast Header	1	
32		Channel, Mast #4 Options:	2	
	1271399	30EL		
	1271397	41EL		
33		Cylinder Assembly Options:	1	
		(See Section 5 for Breakdown)		
	1683699	30EL (Prior to S/N 17519)		
	1684088	30EL (S/N 17519 to Present)		
	1683700	41EL (Prior to S/N 17519)		
34	1684086	41EL (S/N 17519 to Present)	5	
	2880310	Key		
35	3311405	Locknut 1/4-20NC (Prior to S/N 12269)	5	
	3311401	Nut 1/4-20NC (S/N 12269 to Present)		
36	3311505	Locknut 5/16"-18NC	1	
37	3311601	Nut 3/8"-16NC	20	
38	3311605	Locknut 3/8"-16NC	8	
39	3311801	Nut 1/2"-13NC	4	
40	3340845	Pad, Slide Guide	22	
		Pad, Slide Guide Options:		
	Use 3340858	Prior to S/N 15661 (P/N was 3340846)		
41	3340858	S/N 15661 to Present	5	
	3422717	Pin, Sheave		
42	3570893	Plate, Cylinder Mount	2	
43	3580217	Sheave, Cable	4	
44		Sheave Assembly Options:	2	
	3580268	Prior to S/N 17519		
	3580286	S/N 17519 to Present		
45	3580269	Sheave, Sequence Cable	5	
46	3820006	Rivet, 1/4" x 1/2" (Prior to S/N 12269)	20	
	3820034	Rivet, 1/4" x.390" (S/N 12269 to Present)		
47	3900187	Screw, Shoulder	5	
48	3900190	Screw, Shoulder	1	
49	3900192	Screw, Countersunk 3/8"-16NC x 1/2"	16	
50	3900205	Screw, #10-24NC x 1/2"	12	
51	3900206	Bolt, 1/4"-28NF x 5/8"	1	
52	4060960	Shield, Mast Cover	4	
53	4060961	Shield, Mast Cover	1	
54	4070970	Shim, Cylinder Mount	2	
55	4070971	Shim, Cylinder Mount	4	
56	4160124	Spring	5	
57	4567489	Tube, Spacer	2	
58	4567490	Tube, Spacer	1	
59	4567491	Tube, Spacer	2	

**SECTION 3 MAST**

# SECTION 3 MAST

**FIGURE 3-3. MAST ASSEMBLY - 30EL & 41EL (CONTINUED)**

FIG & ITEM #	PART NUMBER	DESCRIPTION	QTY.	REV.
60	4567492	Tube, Spacer	1	
61	4711400	Flatwasher, 1/4" Narrow	80	
62	4711500	Flatwasher, 5/16" Narrow	5	
63	4711800	Flatwasher, 1/2" Narrow	4	
64	4712600	Flatwasher, 1" Narrow	16	
65	4740414	Cup Washer	10	
66	4750800	Flatwasher, 8" Wide	12	
67	4751600	Flatwasher, 3/8" Wide	12	
68	4761000	Lockwasher, #10	12	
69	4761400	Lockwasher, 1/4"	5	
70	4761500	Lockwasher, 5/16"	1	
71	4761600	Lockwasher, 3/8"	4	
72		Weld, Cylinder Mount Options:	1	
	4845731	(Prior to S/N 17519)		
	4846381	(S/N 17519 to S/N 19294)		
	1846514	(S/N 19294 to Present)		
73	4070860	Shim, Slide Pad (.075)	22	
74	4070861	Shim, Slide Pad (.036)	22	
75	4070862	Shim, Slide Pad (.015)	18	
76	Not Used			
77	3580272	Sheave, Assembly (S/N 12354 to Present)	2	
78	4070988	Shim, Slide Pad (.075)	2	
79	4070989	Shim, Slide Pad (.036)	2	
80	4070990	Shim, Slide Pad (.015)	2	
		-----		
		Mast Kit Options:	1	
	2901605	30 EL (Includes Items 26 - 31)		
	2901607	41 EL (Includes Items 26 - 31)		
	1260329	<b>CHAIN ASSEMBLY - #466 CHAIN - 30EL</b>	Rev.	C
	1260330	<b>CHAIN ASSEMBLY - #466 CHAIN - 41EL</b>	Rev.	C
101	0100062	Loctite #RC/640 (Not Shown)	A/R	
102	0561409	Block	1	
103	0561306	Block	1	
104	Purchase Assy	Chain		
105	3422265	Pin	2	
106	3450201	Pin, Cotter	4	
107	4300111	Stud	1	
	1260331	<b>CHAIN ASSEMBLY - #534 CHAIN - 30EL</b>	Rev.	C
	1260332	<b>CHAIN ASSEMBLY - #534 CHAIN - 41EL</b>	Rev.	C
201	0100062	Loctite #RC/640 (Not Shown)	A/R	
202	0561307	Block	1	
203	0561309	Block	2	
204	Purchase Assy	Chain		
205	3422721	Pin	1	

**SECTION 3 MAST**

# SECTION 3 MAST

**FIGURE 3-3. MAST ASSEMBLY - 30EL & 41EL (CONTINUED)**

FIG & ITEM #	PART NUMBER	DESCRIPTION	QTY.	REV.
206	3422722	Pin	2	
207	3450202	Pin, Cotter	4	
208	4300111	Stud	2	
	1260333	<b>CHAIN ASSEMBLY - #544 CHAIN - 30EL</b>	Rev.	B
	1260334	<b>CHAIN ASSEMBLY - #544 CHAIN - 41EL</b>	Rev.	B
301	0100062	Loctite #RC/640 (Not Shown)	A/R	
302	0561305	Block	1	
303	0561308	Block	2	
304	Purchase Assy	Chain		
305	3422720	Pin	2	
306	3450202	Pin, Cotter	4	
307	4300129	Stud	1	

**SECTION 3 MAST**

# SECTION 3 MAST

FIGURE 3-3. MAST ASSEMBLY - 30EL & 41EL (CONTINUED)

FIG & ITEM #	PART NUMBER	DESCRIPTION	QTY.	REV.

**S  
E  
C  
T  
I  
O  
N  
  
3  
  
M  
A  
S  
T**

# SECTION 3 MAST

## FIGURE 3-4. MAST MOUNTED COMPONENTS INSTALLATIONS

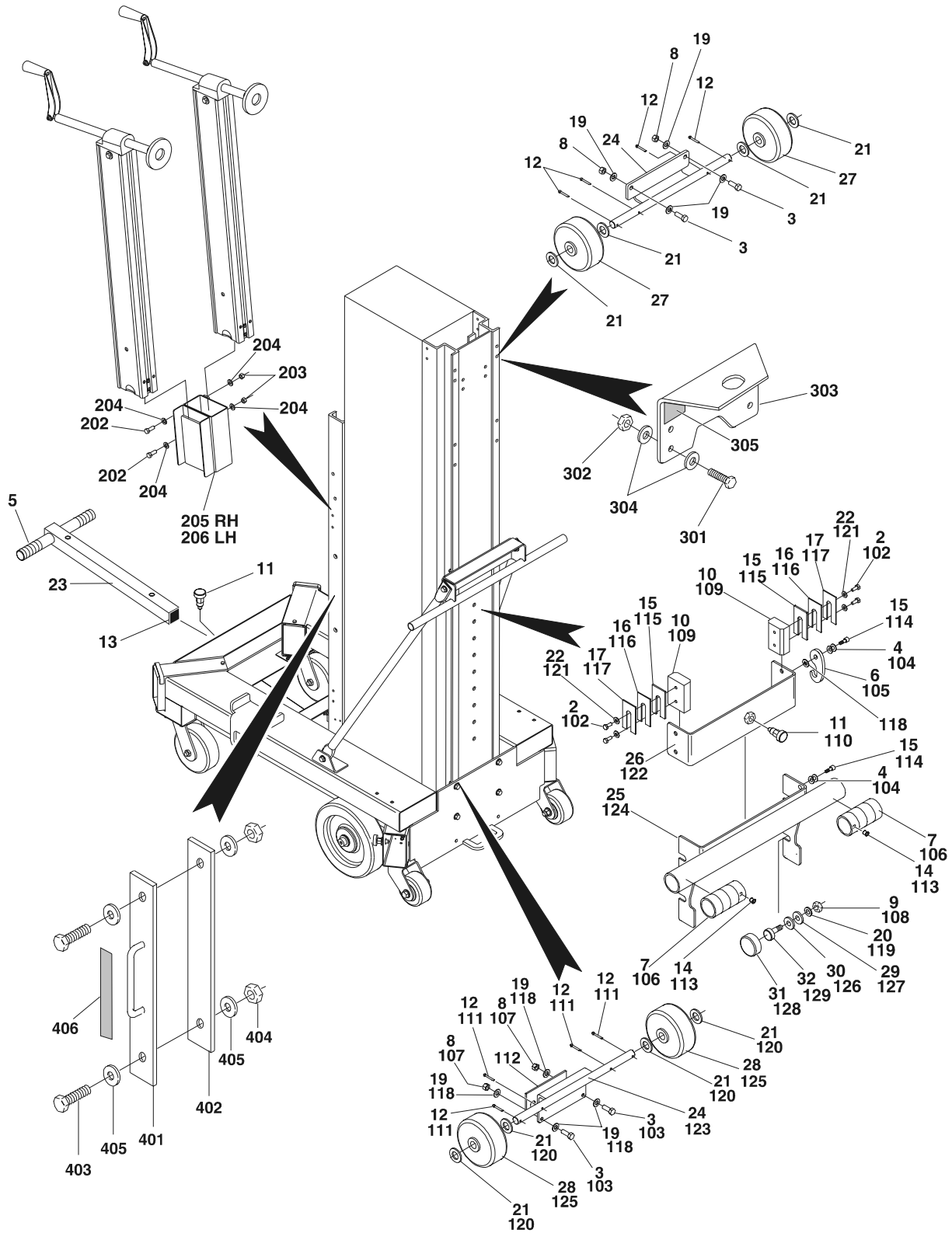

SECTION 3 MAST

# SECTION 3 MAST

**FIGURE 3-4. MAST MOUNTED COMPONENTS INSTALLATIONS**

FIG & ITEM #	PART NUMBER	DESCRIPTION	QTY.	REV.
	0258741	<b>LOADING HARDWARE INSTALLATION 20EL/25EL/30EL</b>	Ref.	F
1	0100011	Loctite #242 (Not Shown)	A/R	
2	0641409	Bolt 1/4"-20NC x 1 1/8"	4	
3	0641608	Bolt 3/8"-16NC x 1"	4	
4	0961892	Bushing, Flanged	2	
5	2560088	Handle	2	
6	2700092	Hook	1	
7	2720130	Hose	2	
8	3311605	Locknut 3/8"-16NC	4	
9	3321701	Nut 7/16"-20NC	4	
10	3340845	Pad, Slide Guide	2	
11	3422744	Pin, Plunger	2	
12	3450504	Pin, Cotter	8	
13	3520163	End Cap, Tube	1	
14	3820032	Rivet	2	
15	3900190	Screw, Shoulder	2	
16	4070860	Shim (.075)	2	
17	4070861	Shim (.036)	2	
18	4070862	Shim (.015)	2	
19	4711600	Washer 3/8"	9	
20	4711700	Washer 7/16"	8	
21	4712200	Washer 3/4"	10	
22	4751400	Washer 1/4" - Wide	4	
23	4845706	Weldment, T-Bar	1	
24	4845727	Bracket, Mast Wheel	2	
25	4845868	Weldment	1	
26	4845869	Weldment	1	
27	4860186	Wheel 5"	2	
28		Wheel 4" Options:	A/R	
	4860185	Wheel (Prior to S/N 14095)	2	
	7020087	Wheel, Replacement (1 Per Wheel)	2	
	7020084	Bearing (2 Per Wheel)	4	
	7012631	Bushing, Axle Spanner (1 Per Wheel)	2	
	4860196	Wheel (S/N 14095 to Present)	2	A
	Not Available	Wheel, Replacement (1 Per Wheel)	2	
	7020084	Bearing (2 Per Wheel)	4	
	Not Available	Bushing, Axle Spanner (1 Per Wheel)	2	
29	AN960-T16L-1	Washer, Shim	4	
30	AN960-T16L-2	Washer, Shim	6	
31		Cap, Roller Options:	4	
	APL-P117	Prior to S/N 14776		
	AM-P2117	S/N 14776 to Present		
32	BB6-CF-1-S	Cam Follower	4	

SECTION 3 MAST

# SECTION 3 MAST

**FIGURE 3-4. MAST MOUNTED COMPONENTS INSTALLATIONS (CONTINUED)**

FIG & ITEM #	PART NUMBER	DESCRIPTION	QTY.	REV.
	0258965	<b>LOADING HARDWARE INSTALLATION 36EL/41EL</b>	Ref.	D
101	0100011	Loctite #242 (Not Shown)	A/R	
102	0641409	Bolt 1/4"-20NC x 1 1/8"	4	
103	0641608	Bolt 3/8"-16NC x 1"	4	
104	0961892	Bushing, Flanged	2	
105	2700092	Hook	1	
106	2720130	Hose	2	
107	3311605	Locknut 3/8"-16NC	4	
108	3321701	Nut 7/16"-20NC	4	
109	3340845	Pad, Slide Guide	2	
110	3422744	Pin, Plunger	1	
111	3450504	Pin, Cotter	4	
112	4070981	Shim (.25)	1	
113	3820032	Rivet	2	
114	3900190	Screw, Shoulder	2	
115	4070860	Shim (.075)	2	
116	4070861	Shim (.036)	2	
117	4070862	Shim (.015)	2	
118	4711600	Washer 3/8"	9	
119	4711700	Washer 7/16"	8	
120	4712200	Washer 3/4"	6	
121	4751400	Washer 1/4" - Wide	4	
122	4845869	Weldment, Pin Plate	1	
123	4845945	Weldment, Mast Wheel Bracket	1	
124	4845946	Weldment, Load Hardware	1	
125		Wheel 4" Options:	A/R	
	4860185	Wheel (Prior to S/N 14095)	2	
	7020087	Wheel, Replacement (1 Per Wheel)	2	
	7020084	Bearing (2 Per Wheel)	4	
	7012631	Bushing, Axle Spanner (1 Per Wheel)	2	
	4860196	Wheel (S/N 14095 to Present)	2	A
	Not Available	Wheel, Replacement (1 Per Wheel)	2	
	7020084	Bearing (2 Per Wheel)	4	
	Not Available	Bushing, Axle Spanner (1 Per Wheel)	2	
126	AN960-T16L-1	Washer, Shim	4	
127	AN960-T16L-2	Washer, Shim	6	
128		Cap, Roller Options:	4	
	APL-P117	Prior to S/N 14776		
	AM-P2117	S/N 14776 to Present		
129	BB6-CF-1-S	Cam Follower	4	
		<b>OUTRIGGER STOWAGE INSTALLATIONS</b>		
	0258553	<b>20 EL/25EL</b>	Ref.	A
	0258554	<b>30EL</b>	Ref.	A
	0258555	<b>36EL/41EL</b>	Ref.	A
201	Not Used			
202	0641608	Bolt 3/8"-16NC x 1"	4	

**SECTION 3 MAST**



# SECTION 3 MAST

**FIGURE 3-4. MAST MOUNTED COMPONENTS INSTALLATIONS (CONTINUED)**

FIG & ITEM #	PART NUMBER	DESCRIPTION	QTY.	REV.
203	3311605	Locknut 3/8"-16NC	4	
204	4711600	Washer 3/8"	8	
205	4845717	Stowage Rack Weldment (Left Side)	1	
206	4845728	Stowage Rack Weldment (Right Side)	1	
	0258448	<b>OPTIONAL CRANE HOOK INSTALLATION</b>	Ref.	C
301	0641612	Bolt 3/8"-16NC x 1 1/2"	4	
302	3311605	Locknut 3/8"-16NC	4	
303	3570976	Plate, Crane Hook	1	
304	4711600	Flatwasher 3/8"	8	
305	1703455	Decal - Crane Hook	1	
	0256559	<b>SAFETY ATTACH INSTALLATION</b>	Ref.	3
401	4845345	Weldment, Safety Attach	1	
402	3539814	Plate	1	
403	0681812	Bolt 1/2"-13NC x 1 1/2"	2	
404	3271805	Locknut 1/2"-13NC	2	
405	4751800	Flatwasher 1/2"	4	
406		Decal - Lanyard Attach Options:	1	
	1702612	(Prior to S/N 18765)		
	1704277	(S/N 18765 to Present)		

SECTION 3 MAST

# SECTION 3 MAST

FIGURE 3-4. MAST MOUNTED COMPONENTS INSTALLATIONS (CONTINUED)

FIG & ITEM #	PART NUMBER	DESCRIPTION	QTY.	REV.

**S  
E  
C  
T  
I  
O  
N  
  
3  
  
M  
A  
S  
T**

# SECTION 4 PLATFORM

## TABLE OF CONTENTS

FIGURE	DESCRIPTION	PAGE
4-1	STEP-IN MOLDED PLATFORM INSTALLATION . . . . .	4-2
4-2	QUICK-CHANGE PLATFORM INSTALLATION . . . . .	4-6
4-3	QUICK-CHANGE PLATFORM INSTALLATION WITH GULLWING GATE . . . . .	4-8
4-4	OPTIONAL PLATFORM COMPONENTS INSTALLATIONS . . . . .	4-12

# SECTION 4 PLATFORM



# SECTION 4 PLATFORM

**FIGURE 4-1. STEP-IN MOLDED PLATFORM INSTALLATION**

FIG & ITEM #	PART NUMBER	DESCRIPTION	QTY.	REV.
	0258477	<b>STEP-IN MOLDED PLATFORM INSTALLATION</b>	Ref.	A
1	0258672	Platform Assembly (See Items 101 - 134 for Breakdown)	1	
2	0641408	Bolt 1/4"-20NC x 1"	8	
3	0860520	Box, Manual Storage	1	
4	1060380	Cable, Lanyard	4	
5	3311405	Nut 1/4"-20NC	8	
6	3422657	Pin, Ball Detent	4	
7	3820024	Rivet	4	
8	4711400	Flatwasher 1/4"	16	
9	4845821	Platform Mount Weldment	2	
	0258672	<b>STEP-IN MOLDED PLATFORM ASSEMBLY</b>	Ref.	3
101	4845822	Rail	1	
102	3510676	Basket	1	
103	4060882	Cover	1	
104	4845831	Bottom Mount Weldment	1	
105	0641416	Bolt 1/4"-20NC x 2"	10	
106	4751400	Flatwasher 1/4"	22	
107	3520072	Cap	4	
108	3311405	Locknut 1/4"-20NC	12	
109	4160125	Spring, Gas	1	
110	0362347	Link, Gate	1	
111	3640924	Rail, Gate (Top)	1	
112	3640990	Rail, Gate (Bottom)	1	
113	4711500	Flatwasher	1	
114	3311505	Locknut 5/16"-18NC	1	
115	3340746	Pad, Gate Rest	1	
116	3911032	Screw #10-24NC x 2"	4	
117	4751000	Flatwasher #10	8	
118		Flex-Trim Options:	2ft	
	4060803	Prior to S/N 18809		
	4060804	S/N 18809 to Present		
119	3311001	Nut #10-24NC	4	
120	4070890	Shim, Gate Stop	2	
121	3340754	Pad, Gate Latch	1	
122	3900177	Screw, Plastite	6	
123	3900202	Bolt, Shoulder 1/4" x 1/4"	2	
124	4740429	Washer, Nylon	4	
125	3311005	Locknut #10-24NC	2	
126	3900203	Bolt, Shoulder 5/16" x 1 1/2"	2	
127	4740428	Washer, Nylon	4	
128	3300151	Nut, Acorn 1/4"-20NC	2	
129	0100011	Loctite #242	A/R	
130	2940082	Latch, Gate	1	
131	3520028	Plug 1/2"	5	

**SECTION 4 PLATFORM**

# SECTION 4 PLATFORM

FIGURE 4-1. STEP-IN MOLDED PLATFORM INSTALLATION (CONTINUED)

FIG & ITEM #	PART NUMBER	DESCRIPTION	QTY.	REV.
132	Not Used			
133	3820024	Rivet	2	
134	4070894	Shim, Gate Latch	1	

**S  
E  
C  
T  
I  
O  
N  
  
4  
  
P  
L  
A  
T  
F  
O  
R  
M**

# SECTION 4 PLATFORM

FIGURE 4-1. STEP-IN MOLDED PLATFORM INSTALLATION (CONTINUED)

FIG & ITEM #	PART NUMBER	DESCRIPTION	QTY.	REV.

**S  
E  
C  
T  
I  
O  
N  
  
4  
  
P  
L  
A  
T  
F  
O  
R  
M**

# SECTION 4 PLATFORM

FIGURE 4-2. QUICK-CHANGE PLATFORM INSTALLATION

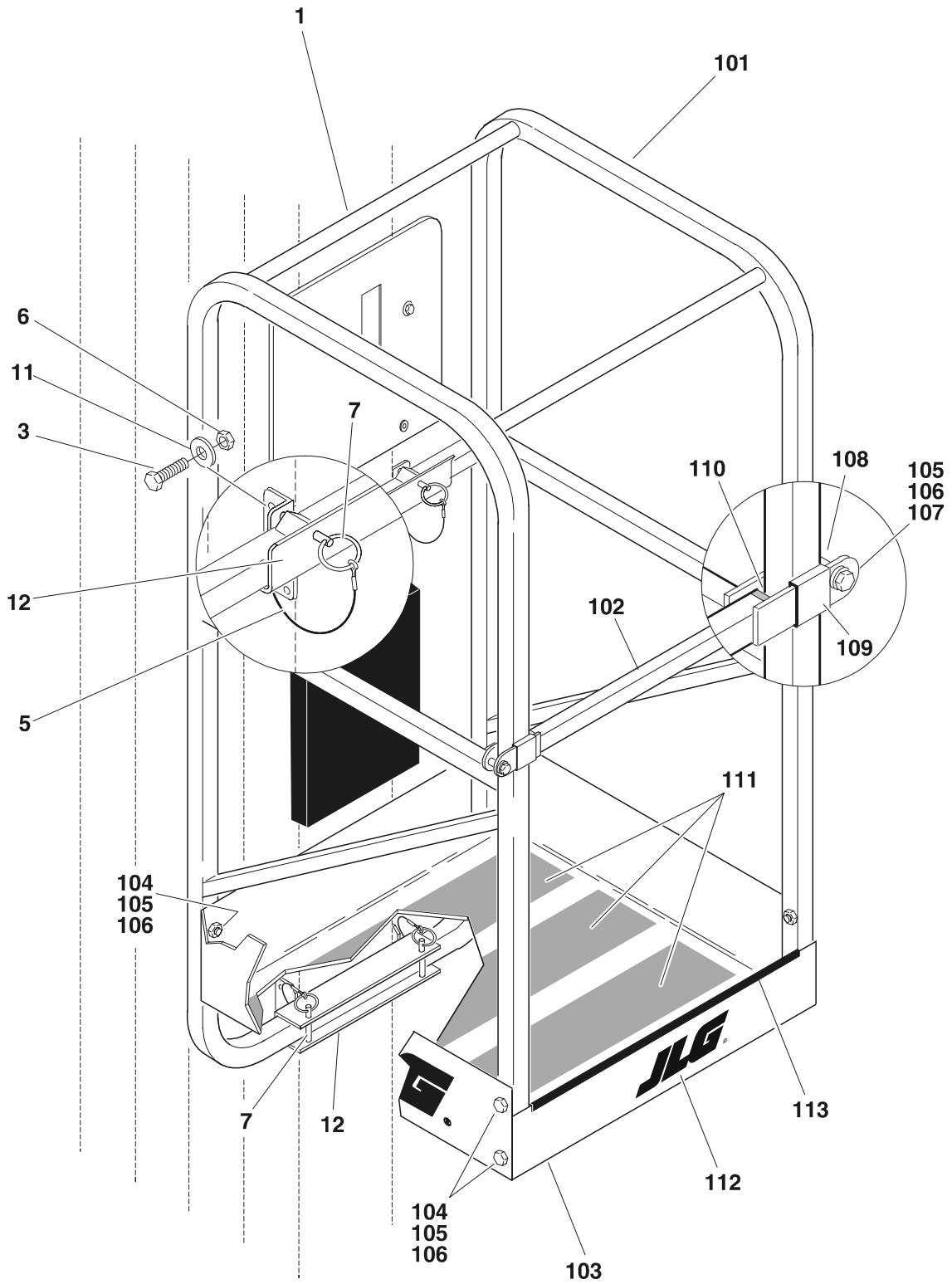

SECTION 4 PLATFORM



# SECTION 4 PLATFORM

**FIGURE 4-2. QUICK-CHANGE PLATFORM INSTALLATION**

FIG & ITEM #	PART NUMBER	DESCRIPTION	QTY.	REV.
		<b>PLATFORM INSTALLATION OPTIONS:</b>	Ref.	
	0258673	<b>SLIDE RAIL FRONT ENTRY</b>	Ref.	A
	0258474	<b>SLIDE RAIL SIDE ENTRY</b>	Ref.	B
1		Assembly, Platform 26" x 26" Options:	1	
	0257711	Platform with Front Entry		
	0258562	Platform with Side Entry		
2	0641408	Bolt, 1/4"-20NC x 1"	8	
3	0860520	Box, Manual Storage	1	
4	1060380	Cable, Lanyard	4	
5	3311405	Locknut, 1/4"-20NC	10	
6	3422657	Pin, Quick Release	4	
7	3820024	Rivet	4	
8	4711400	Flatwasher 1/4" Narrow	20	
9	4845821	Mounting Bracket Weldment	2	
		<b>PLATFORM ASSEMBLY OPTIONS:</b>		
	0257711	<b>SLIDE RAIL FRONT ENTRY</b>	Ref.	6
	0258562	<b>SLIDE RAIL SIDE ENTRY</b>	Ref.	B
101		Platform Rail Weldment Options:	1	
	4845577	Slide Rail Front Entry		
	4845796	Slide Rail Side Entry		
102		Gate Weldment Options:	1	
	4845578	Prior to S/N 16855		
	4845797	S/N 16855 to Present		
103		Plate, Platform Pan Options:	1	
	3570435	Slide Rail Front Entry		
	3570986	Slide Rail Side Entry		
104	0641414	Bolt, 1/4"-20NC x 1 3/4"	8	
105	4711400	Flatwasher, 1/4" Narrow	20	
106	3311405	Locknut, 1/4"-20NC	10	
107	0641418	Bolt, 1/4"-20NC x 2 1/4"	2	
108	0961845	Bushing	2	
109	4280296	Strip, Wear	1.5ft/46cm	
110	3520169	Plug, Cap	2	
111	4420039	Tape, Non-Skid	6ft/1.8m	
112	Use 1703681	Decal, JLG (Prior to S/N 20241) (Was P/N 1701612)	3	
	1703681	(S/N 20241 to Present)		
113	4060803	Shield, Flex Trim	A/R	

SECTION 4 PLATFORM

# SECTION 4 PLATFORM

FIGURE 4-3. QUICK-CHANGE PLATFORM INSTALLATION WITH GULLWING GATE

SECTION  
4  
PLATFORM

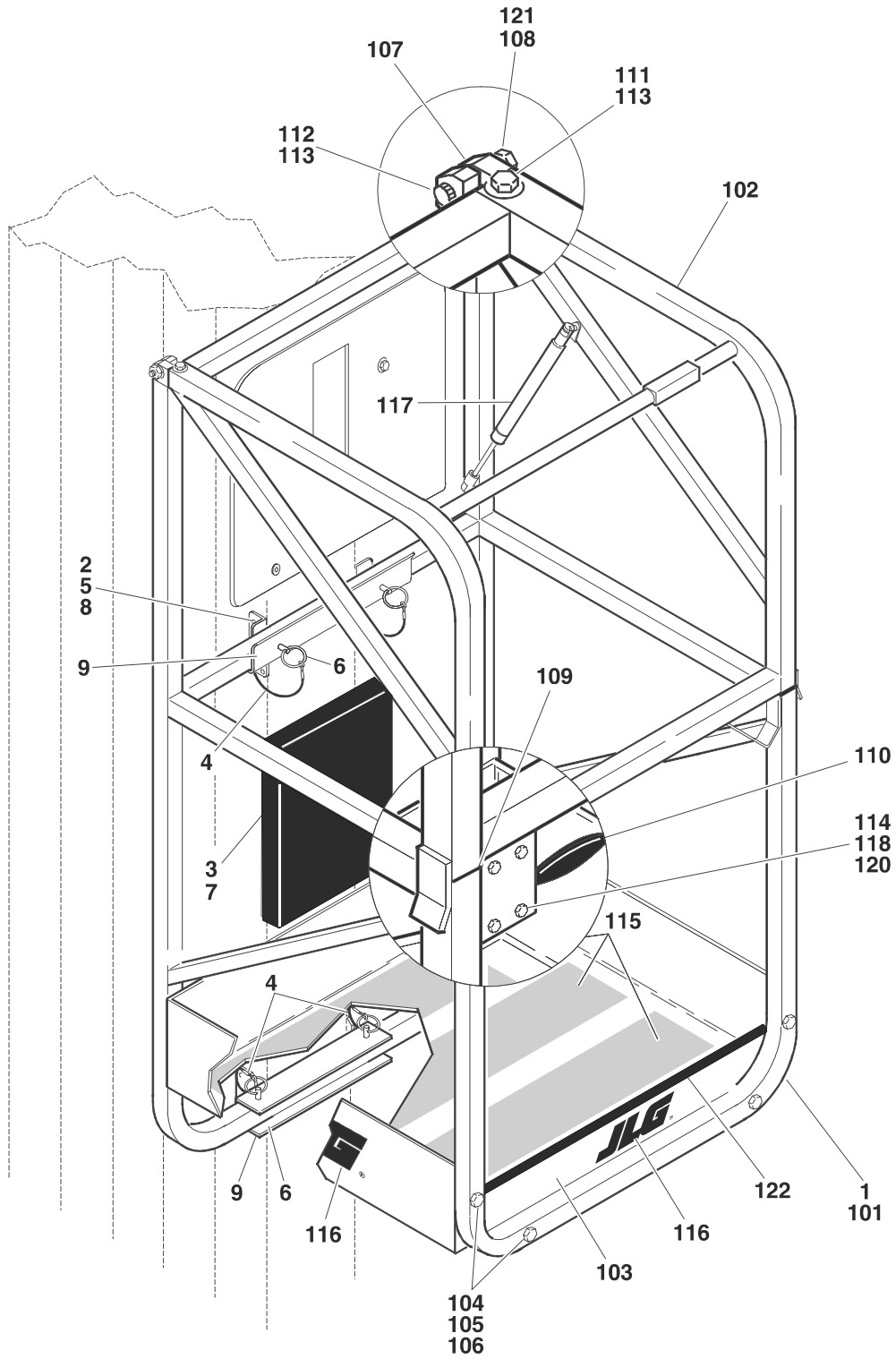

# SECTION 4 PLATFORM

**FIGURE 4-3. QUICK-CHANGE PLATFORM INSTALLATION WITH GULLWING GATE**

FIG & ITEM #	PART NUMBER	DESCRIPTION	QTY.	REV.
		<b>PLATFORM INSTALLATION OPTIONS:</b>	Ref.	
	0258476	<b>22" X 25" (56cm x 63.5cm)</b>	Ref.	B
	0258475	<b>28" x 26" (71cm x 66cm)</b>	Ref.	B
1		Assembly, Platform Options (See Item 101 - 122 for Breakdown):	1	
	0258587	22" X 25" (56cm x 63.5cm)		
	0258588	28" x 26" (71cm x 66cm)		
2	0641408	Bolt, 1/4"-20NC x 1"	8	
3	0860520	Box, Manual Storage	1	
4	1060380	Cable, Lanyard	4	
5	3311405	Locknut, 1/4"-20NC	10	
6	3422657	Pin, Quick Release	4	
7	3820024	Rivet	4	
8	4711400	Flatwasher 1/4" Narrow	20	
9	4845821	Mounting Bracket Weldment	2	
		<b>PLATFORM ASSEMBLIES</b>	Ref.	
	0258587	<b>22" X 25" (56cm x 63.5cm)</b>	Ref.	4/D
	0258588	<b>28" x 26" (71cm x 66cm)</b>	Ref.	5/D
101		Platform Rail Weldment Options:	1	
	4845809	22" X 25" (56cm x 63.5cm)		
	4845808	28" x 26" (71cm x 66cm)		
102		Gullwing Gate Weldment Options:	1	
	4845805	22" X 25" (56cm x 63.5cm)		
	4845813	28" x 26" (71cm x 66cm)		
103		Plate, Platform Pan Options:	1	
	3570464	22" X 25" (56cm x 63.5cm)		
	3570462	28" x 26" (71cm x 66cm)		
104	0641414	Bolt 1/4"-20NC x 1 3/4"	8	
105	4711400	Flatwasher 1/4"	16	
106	3311405	Locknut 1/4"-20NC	8	
107	2600225	Hinge, Gate	4	
108	3311505	Locknut 5/16"-18NC	2	
109	3520072	Cap, Plug	4	
110	2940074	Latch	1	
111	3900258	Screw, Button Head 1/4"-20NC x 3/4"	8	
112	3900032	Bolt, Shoulder	2	
113	4711600	Flatwasher 3/8"	2	
114	0721006	Bolt #10-24NC x 3/4"	4	
115	4420039	Tape, Non-Skid Options:	A/R	
		22" X 25" (56cm x 63.5cm)	3.75ft/1.1m	
		28" x 26" (71cm x 66cm)	6ft/1.8m	
116	Use 1703681	Decal, JLG (Prior to S/N 20241) (Was P/N 1701612)	3	
	1703681	(S/N 20241 to Present)		
117	4160165	Spring, Gas Shock	1	
118	4851000	Flatwasher #10	8	

**SECTION 4 PLATFORM**

# SECTION 4 PLATFORM

FIGURE 4-3. QUICK-CHANGE PLATFORM INSTALLATION WITH GULLWING GATE (CONTINUED)

FIG & ITEM #	PART NUMBER	DESCRIPTION	QTY.	REV.
119	Not Used			
120	3311005	Locknut #10-24NC	4	
121	3300356	Nut-Acorn 5/16"-18NC	2	
122	4060803	Shield, Flex Trim	A/R	

**S  
E  
C  
T  
I  
O  
N  
  
4  
  
P  
L  
A  
T  
F  
O  
R  
M**

# SECTION 4 PLATFORM

FIGURE 4-3. QUICK-CHANGE PLATFORM INSTALLATION WITH GULLWING GATE (CONTINUED)

FIG & ITEM #	PART NUMBER	DESCRIPTION	QTY.	REV.

**S  
E  
C  
T  
I  
O  
N  
  
4  
  
P  
L  
A  
T  
F  
O  
R  
M**

# SECTION 4 PLATFORM

FIGURE 4-4.OPTIONAL PLATFORM COMPONENT INSTALLATIONS

SECTION  
4  
PLATFORM

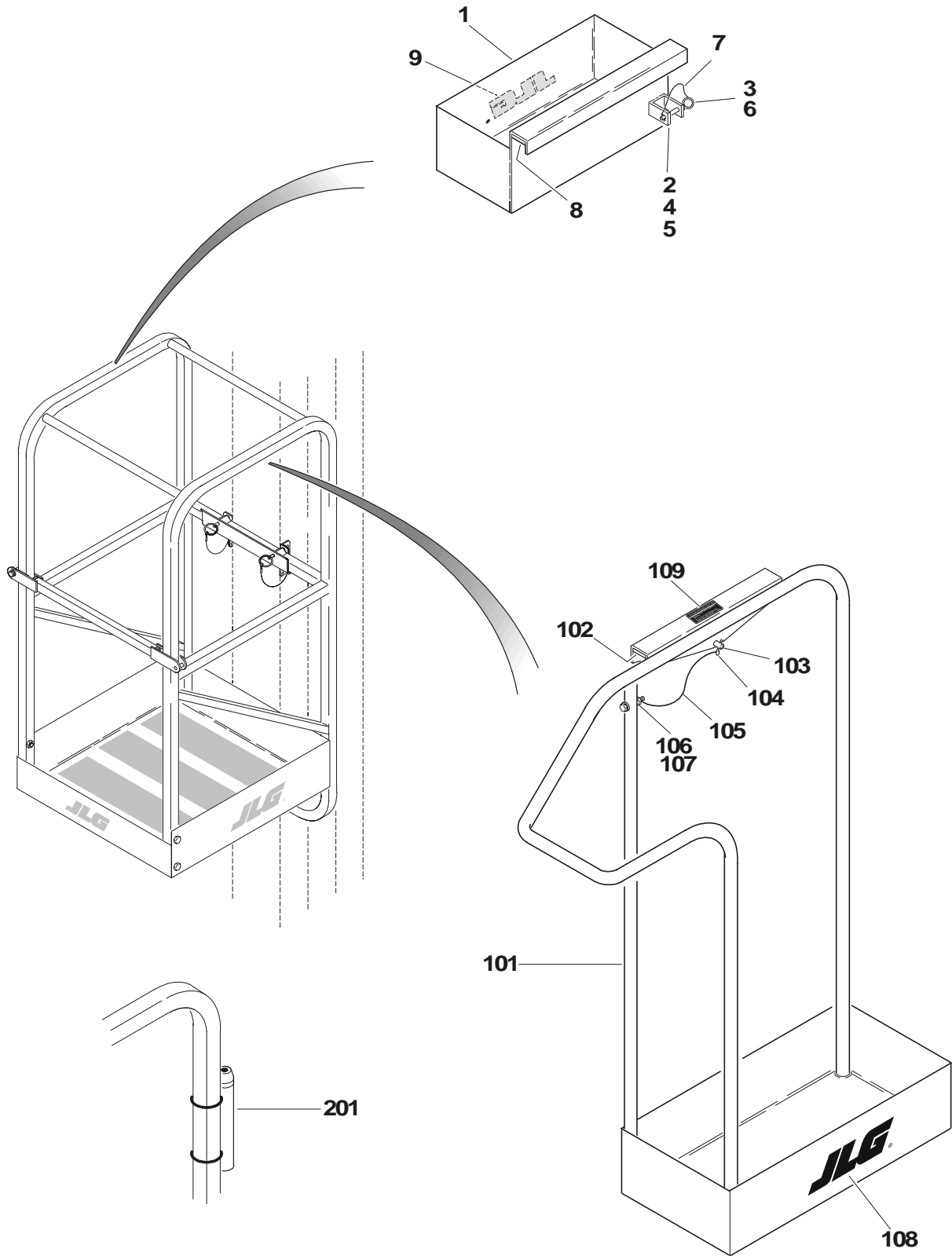

# SECTION 4 PLATFORM

**FIGURE 4-4. OPTIONAL PLATFORM COMPONENT INSTALLATIONS**

FIG & ITEM #	PART NUMBER	DESCRIPTION	QTY.	REV.
	0255036	<b>TOOL TRAY ASSEMBLY</b>	Ref.	—
1	0860947	Tool Box	1	
2	0902079	Bracket, Mounting	1	
3	3421453	Pin, Snap	1	
4	3900204	Bolt, Carriage #10-24NC x 1/2"	2	
5	3300391	Wingnut #10-24NC	2	
6	3760170	Snap-Pin	1	
7	1060380	Cable, Lanyard	1	
8	4280296	Strip, Wear	4ft/1.2m	
9	1702365	Decal - JLG	1	
	0255040	<b>TUBE CADDY ASSEMBLY</b>	Ref.	B
101	4844840	Tube Caddy	1	
102	4280296	Strip, Wear	2ft/.61m	
103	3421453	Pin, Snap	1	
104	3760170	Snap-Pin	1	
105	1060380	Cable, Lanyard	1	
106	0641410	Bolt 1/4"-20NC x 1 1/4"	1	
107	3311405	Locknut 1/4"-20NC	1	
108	1702365	Decal - JLG	1	
109	1706326	Decal - 15# Max Capacity (S/N 23508 to Present)	1	
	0255853	<b>LASER LOCATOR INSTALLATION</b>	Ref.	B
201	4566847	Tube, Mounting	1	
	0750802	Screw #8 x 1/4"	2	
		Clamp, Spring Options:	2	
	1320218	Prior to S/N 20302		
	1380132	S/N 20302 to Present		
	2920127	Pointer, Laser	1	
	4460425	Connector, Strain Relief	1	

**SECTION 4 PLATFORM**

# SECTION 4 PLATFORM

FIGURE 4-4. OPTIONAL PLATFORM COMPONENT INSTALLATIONS (CONTINUED)

FIG & ITEM #	PART NUMBER	DESCRIPTION	QTY.	REV.

**S  
E  
C  
T  
I  
O  
N  
  
4  
  
P  
L  
A  
T  
F  
O  
R  
M**



# SECTION 5 CYLINDER

## TABLE OF CONTENTS

FIGURE	DESCRIPTION	PAGE
5-1	LIFT CYLINDER ASSEMBLY (PRIOR TO S/N 17519).....	5-2
5-2	LIFT CYLINDER ASSEMBLY (S/N 17519 TO PRESENT).....	5-4

**S  
E  
C  
T  
I  
O  
N  
  
5  
  
C  
Y  
L  
I  
N  
D  
E  
R**

# SECTION 5 CYLINDER

FIGURE 5-1. LIFT CYLINDER ASSEMBLY (PRIOR TO S/N 17519)

SECTION 5 CYLINDER

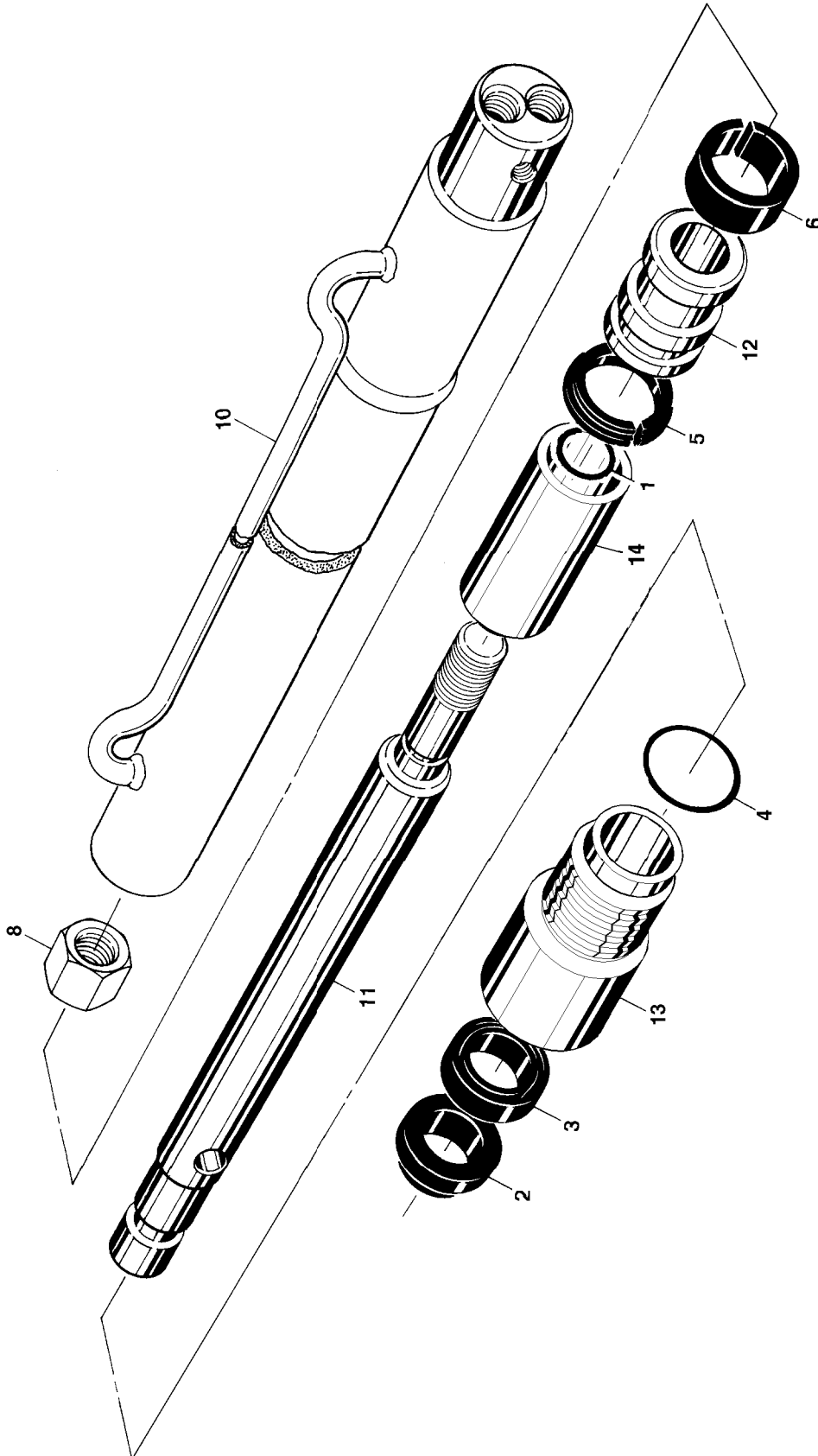

# SECTION 5 CYLINDER

**FIGURE 5-1. LIFT CYLINDER ASSEMBLY (PRIOR TO S/N 17519)**

FIG & ITEM #	PART NUMBER	DESCRIPTION	QTY.	REV.
		<b>LIFT CYLINDER ASSEMBLIES OPTIONS: (PRIOR TO S/N 17519)</b>	Ref.	
	1683699	<b>20EL/25EL/30EL</b>	Ref.	C
	1683693	<b>36EL</b>	Ref.	C
	1683700	<b>41EL</b>	Ref.	C
1	Kit	O-Ring	1	
2	Kit	Wiper	1	
3	Kit	Seal	1	
4	Kit	O-Ring	1	
5	Kit	Seal	1	
6	Kit	Ring, Wear	1	
7	Not Used			
8	7003246	Locknut	1	
9	Not Used			
10		Barrel Options:		
	7019839	20EL/25EL/30EL	1	
	7019837	36EL/41EL	1	
11		Rod Options:		
	7019838	20EL/25EL/30EL	1	
	7019836	36EL/41EL	1	
12	7019835	Piston	1	
13	7019834	Head	1	
14	7019840	Spacer (41EL Only)	1	
	7019833	Seal Kit (Includes Items 1-6)	1	

SECTION 5 CYLINDER

# SECTION 5 CYLINDER

FIGURE 5-2.LIFT CYLINDER ASSEMBLY (S/N 17519 TO PRESENT)

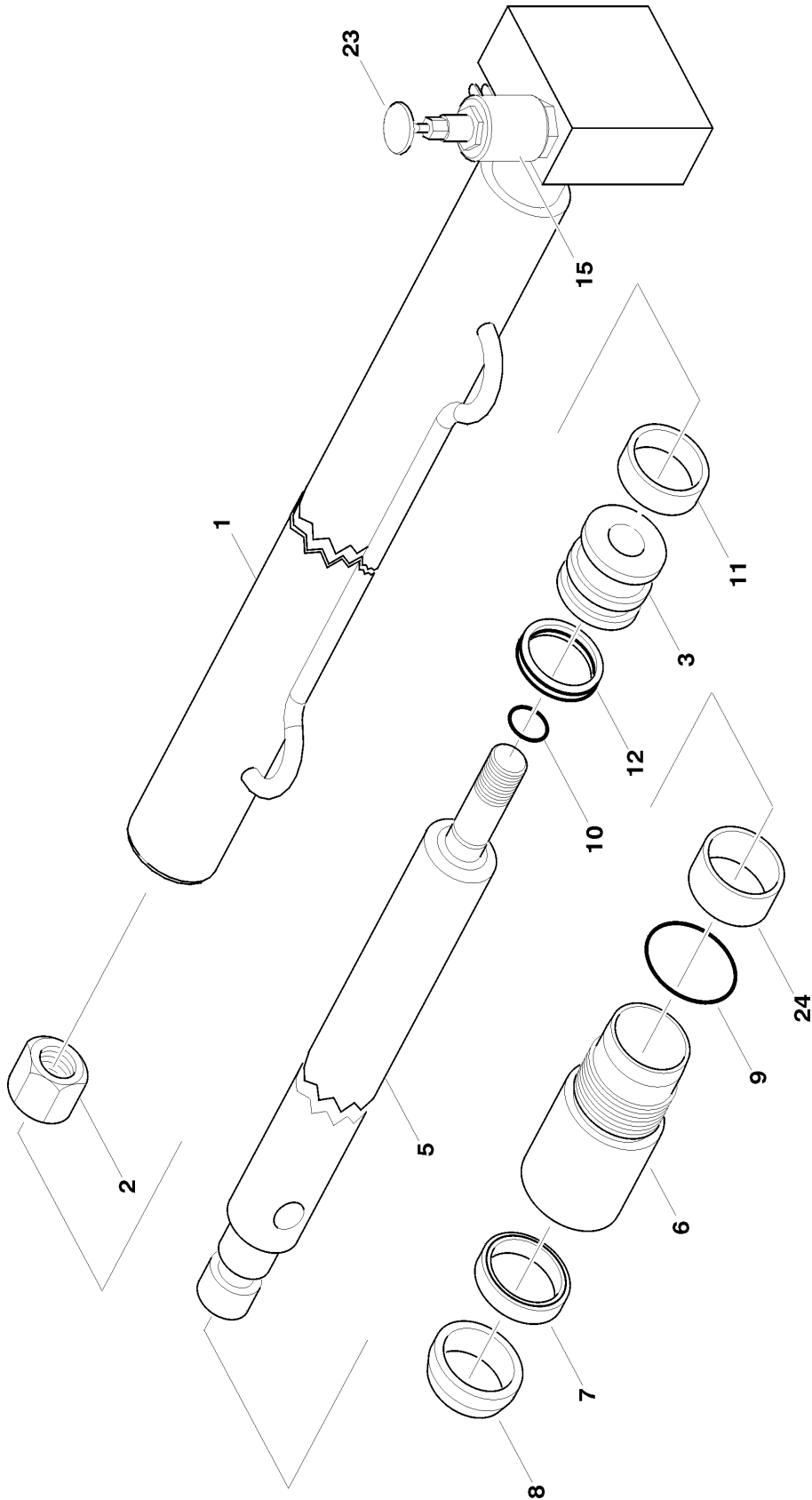

SECTION 5 CYLINDER

# SECTION 5 CYLINDER

**FIGURE 5-2. LIFT CYLINDER ASSEMBLY (S/N 17519 TO PRESENT)**

FIG & ITEM #	PART NUMBER	DESCRIPTION	QTY.	REV.
		<b>LIFT CYLINDER ASSEMBLIES OPTIONS: (S/N 17519 TO PRESENT)</b>	Ref.	
	1684088	<b>20EL/25EL/30EL</b>	Ref.	H
	1684087	<b>36EL</b>	Ref.	G
	1684086	<b>41EL</b>	Ref.	G
1	Not Available	Barrel	1	
2	7023391	Nut	1	
3	7023392	Piston	1	
4	Not Used		1	
5		Rod Options:	1	
	7023393	20EL/25EL/30EL	1	
	7024352	36EL/41EL	1	
6	7023394	Head	1	
7	Kit	Seal, Rod	1	
8	Kit	Rod Wiper	1	
9	Kit	O-Ring	1	
10	Kit	O-Ring	1	
11	Kit	Ring, Wear	1	
12	Kit	Seal, Piston	1	
13	Not Used			
14	Not Used			
15	7023396	Poppet, Solenoid Valve	1	
16	7023397	Spring (Not Shown)	1	
17	7023398	Control Valve (Not Shown)	1	
18	Not Used			
19	Not Used			
20	Not Used			
21	Not Used			
22	Not Used			
23	7023399	Knob - Red	1	
24		Spacer Options:		
	Not Required	20EL/25EL/30EL/36EL	0	
	7024353	41EL		
		-----	1	
	7023395	Seal Kit (Includes Items 7-12)	1	

**SECTION 5 CYLINDER**

# SECTION 5 CYLINDER

FIGURE 5-2. LIFT CYLINDER ASSEMBLY (S/N 17519 TO PRESENT) (CONTINUED)

FIG & ITEM #	PART NUMBER	DESCRIPTION	QTY.	REV.

**S  
E  
C  
T  
I  
O  
N  
  
5  
  
C  
Y  
L  
I  
N  
D  
E  
R**

# SECTION 6 HYDRAULIC

TABLE OF CONTENTS		
FIGURE	DESCRIPTION	PAGE
6-1	HYDRAULIC DIAGRAM .....	6-2

**S  
E  
C  
T  
I  
O  
N  
  
6  
  
H  
Y  
D  
R  
A  
U  
L  
I  
C**

# SECTION 6 HYDRAULIC

FIGURE 6-1.HYDRAULIC DIAGRAM

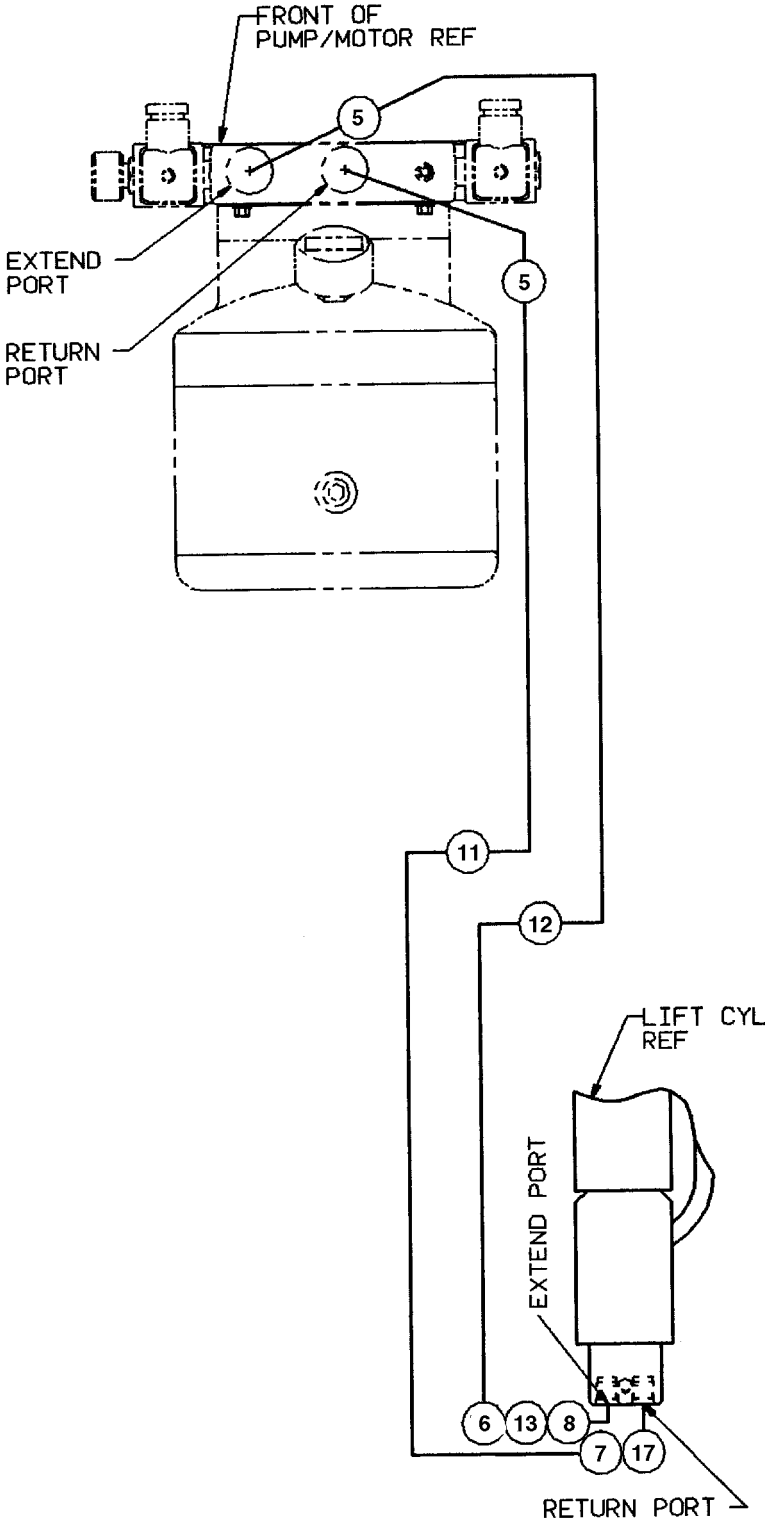

SECTION 6 HYDRAULIC



# SECTION 6 HYDRAULIC

**FIGURE 6-1. HYDRAULIC DIAGRAM**

FIG & ITEM #	PART NUMBER	DESCRIPTION	QTY.	REV.
		<b>HYDRAULIC DIAGRAMS OPTIONS:</b>		
	0258683	<b>20EL (Prior to S/N 17519)</b>	Ref.	C
	0271139	<b>20EL (S/N 17519 to Present)</b>	Ref.	E
	0258478	<b>25EL/30EL/36EL/41EL (Prior to S/N 17519)</b>	Ref.	B
	0271137	<b>25EL/30EL/36EL/41EL (S/N 17519 to Present)</b>	Ref.	D
1	0100020	Sealant, Pipe (Not Shown)	A/R	
2 to 4	Not Used			
5	2220473	Fitting	2	
6	2220773	Fitting, Straight (Prior to S/N 17519 Only)	1	
7		Fitting Options:		
	2220775	(Prior to S/N 12031)	1	
	2220507	(S/N 12031 to 17519)	1	
	Not Required	(S/N 17519 to Present)	0	
8	2220875	Fitting, 90° (Prior to S/N 17519 Only)	1	
9 to 10	Not Used			
11		Tube Options:	1	
	4567669	(Prior to S/N 17519)		
	4568227	(S/N 17519 to Present)		
12		Tube Options:	1	
	4567670	(Prior to S/N 17519)		
	4568228	(S/N 17519 to Present)		
13	4640900	Valve, Flow Control (Prior to S/N 17519 Only)	1	
14 to 16	Not Used			
17	2220603	Fitting	1	

**SECTION 6 HYDRAULIC**

# SECTION 6 HYDRAULIC

FIGURE 6-1. HYDRAULIC DIAGRAM (CONTINUED)

FIG & ITEM #	PART NUMBER	DESCRIPTION	QTY.	REV.

**S  
E  
C  
T  
I  
O  
N  
  
6  
  
H  
Y  
D  
R  
A  
U  
L  
I  
C**

# SECTION 7 ELECTRICAL

## TABLE OF CONTENTS

FIGURE	DESCRIPTION	PAGE
7-1	ELECTRICAL DIAGRAM LIST . . . . .	7-2
7-2	ELECTRICAL DIAGRAM - 12VDC . . . . .	7-4
7-3	ELECTRICAL DIAGRAM - 120VAC . . . . .	7-6

**S  
E  
C  
T  
I  
O  
N  
  
7  
  
E  
L  
E  
C  
T  
R  
I  
C  
A  
L**

# SECTION 7 ELECTRICAL

**FIGURE 7-1. ELECTRICAL DIAGRAM LIST**

FIG & ITEM #	PART NUMBER	DESCRIPTION	QTY.	REV.
		<b>ELECTRICAL DIAGRAMS AND COMPONENTS LIST</b> <b>Note: Diagrams with asterisks (*) are shown in the following pages. Diagrams not shown are available from the JLG Service Department.</b>	Ref.	
		<b>ELECTRICAL DIAGRAM - 12VDC</b>	Ref.	
	4933037	<b>Prior to S/N 14544</b>	Ref.	G/5
	4933186	<b>S/N 14544 to S/N 17519</b>	Ref.	A
	4933203*	<b>S/N 17519 to Present</b>	Ref.	C
		<b>Prior to S/N 14544 Components</b> - Note: Prior to S/N 14544 machines were wired with individual wires not harnesses.		
		Harness, Pump Options:	1	
	4922412	Prior to S/N 14544		
	4922605	S/N 14544 to S/N 17519		
	4922605	S/N 17519 to Present		
	4460044	Fuse Holder	1	
	2400006	Fuse - 5 Amp	1	
	3990010	Diode - 6 Amp	2	
	4460424	Receptacle	1	
	4460268	Socket, Female	2	
	4922420	Harness, Jumper	1	
	3990010	Diode - 6 Amp	1	
	4922421	Harness, Potted Relay	1	
	3740106	Relay, Potted	1	
		<b>ELECTRICAL DIAGRAM - 120VAC</b>	Ref.	
	4933036	<b>Prior to S/N 17519</b>	Ref.	H/4
	4933204*	<b>S/N 17519 to Present</b>	Ref.	G/4
		Harness, Ground Control Options:	1	
	4921661	Prior to S/N 17519		
	4922546	S/N 17519 to Present		
	4460044	Fuseholder	1	
	2400006	Fuse - 5 Amp	1	
	3990010	Diode - 6 Amp	3	
	4460424	Receptacle (Prior to 20697)	1	
	4460268	Socket, Female (Prior to 20697)	2	

**SECTION 7 ELECTRICAL**

# SECTION 7 ELECTRICAL

FIGURE 7-1.ELECTRICAL DIAGRAM LIST

FIG & ITEM #	PART NUMBER	DESCRIPTION	QTY.	REV.

**S  
E  
C  
T  
I  
O  
N  
  
7  
  
E  
L  
E  
C  
T  
R  
I  
C  
A  
L**

# SECTION 7 ELECTRICAL

FIGURE 7-2. ELECTRICAL DIAGRAM - 12VDC

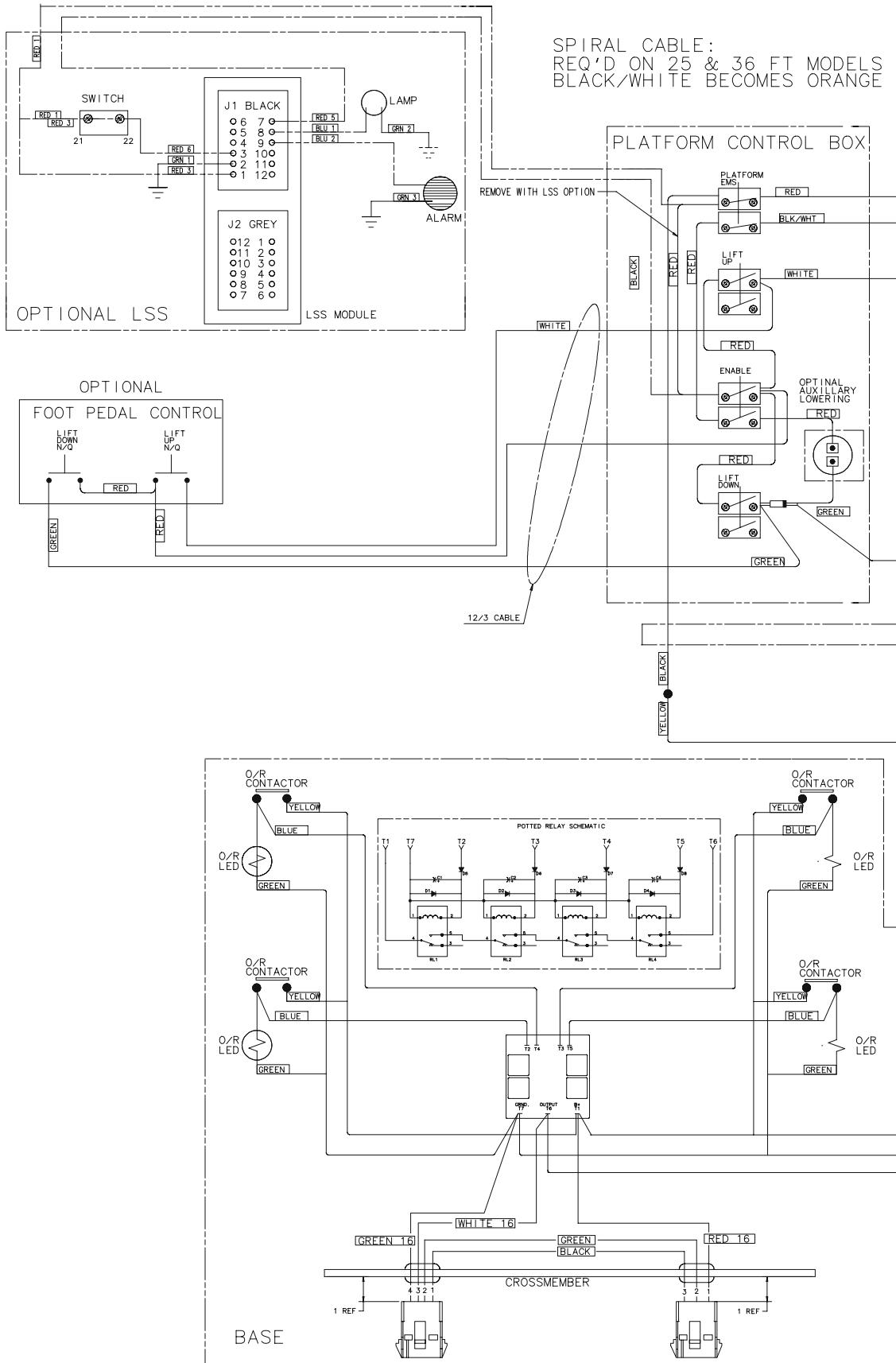

SECTION 7 ELECTRICAL

# SECTION 7 ELECTRICAL

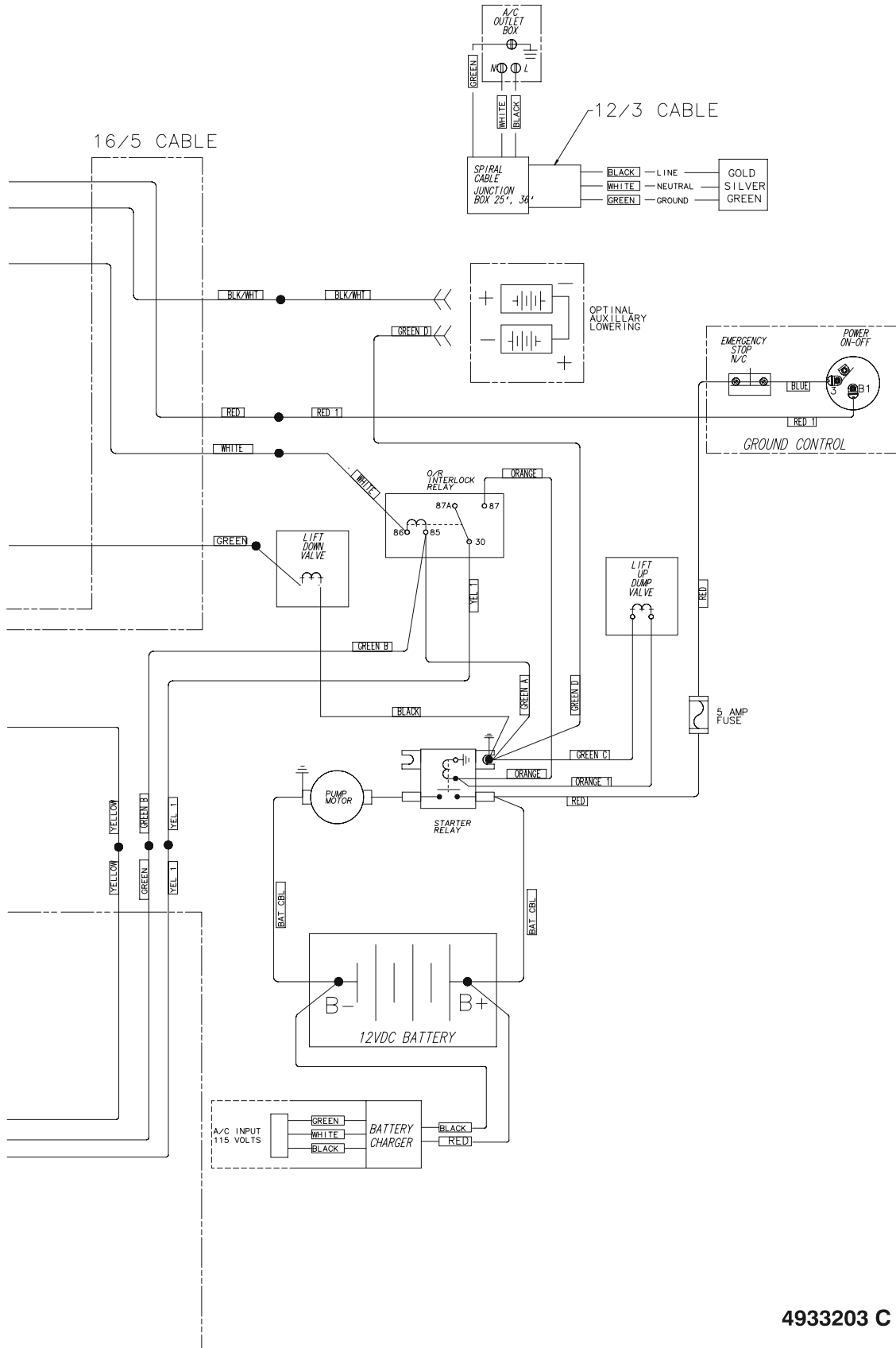

**SECTION 7 ELECTRICAL**

4933203 C

# SECTION 7 ELECTRICAL

FIGURE 7-3. ELECTRICAL DIAGRAM - 120VAC

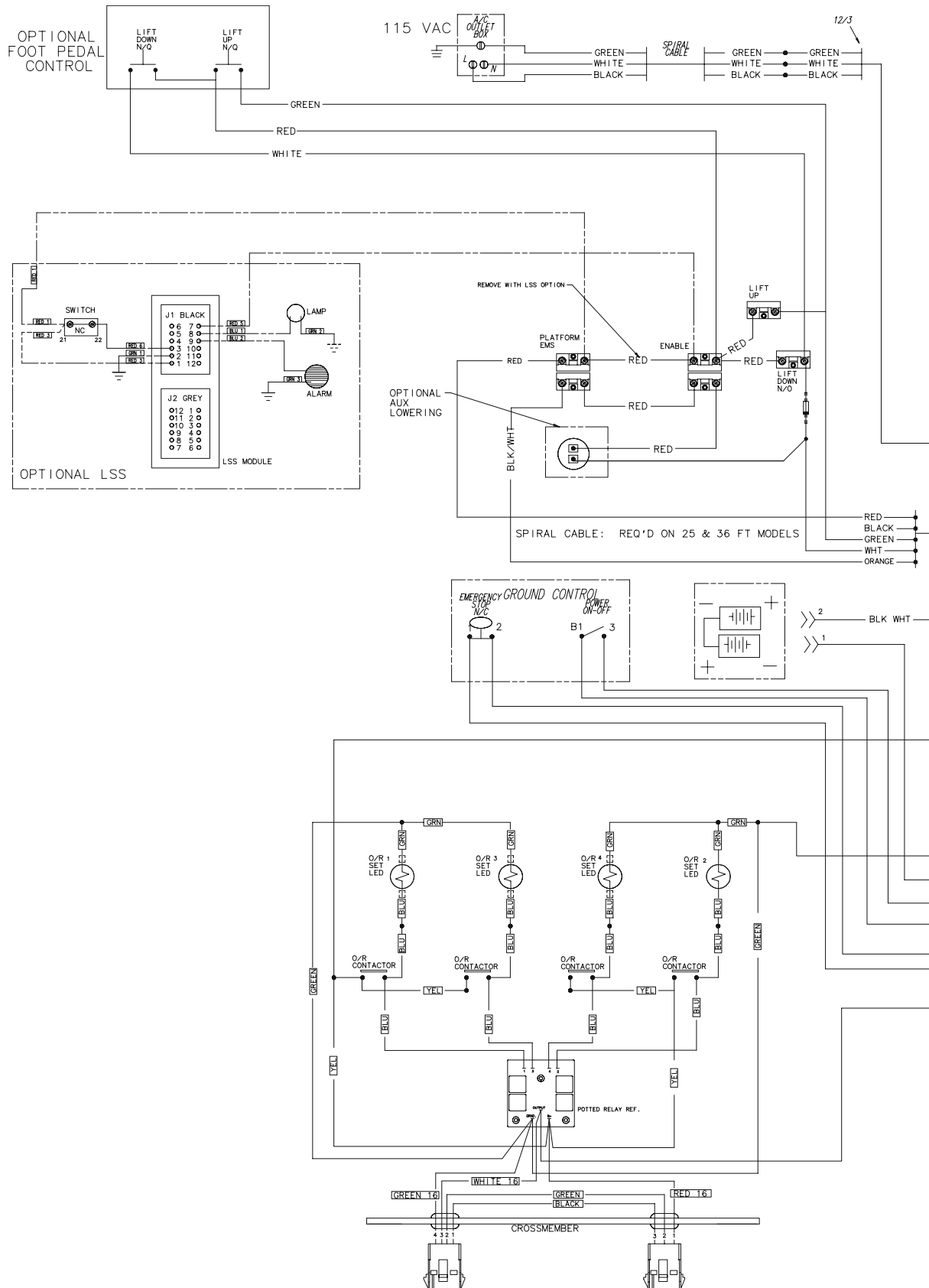

SECTION 7 ELECTRICAL



# SECTION 7 ELECTRICAL

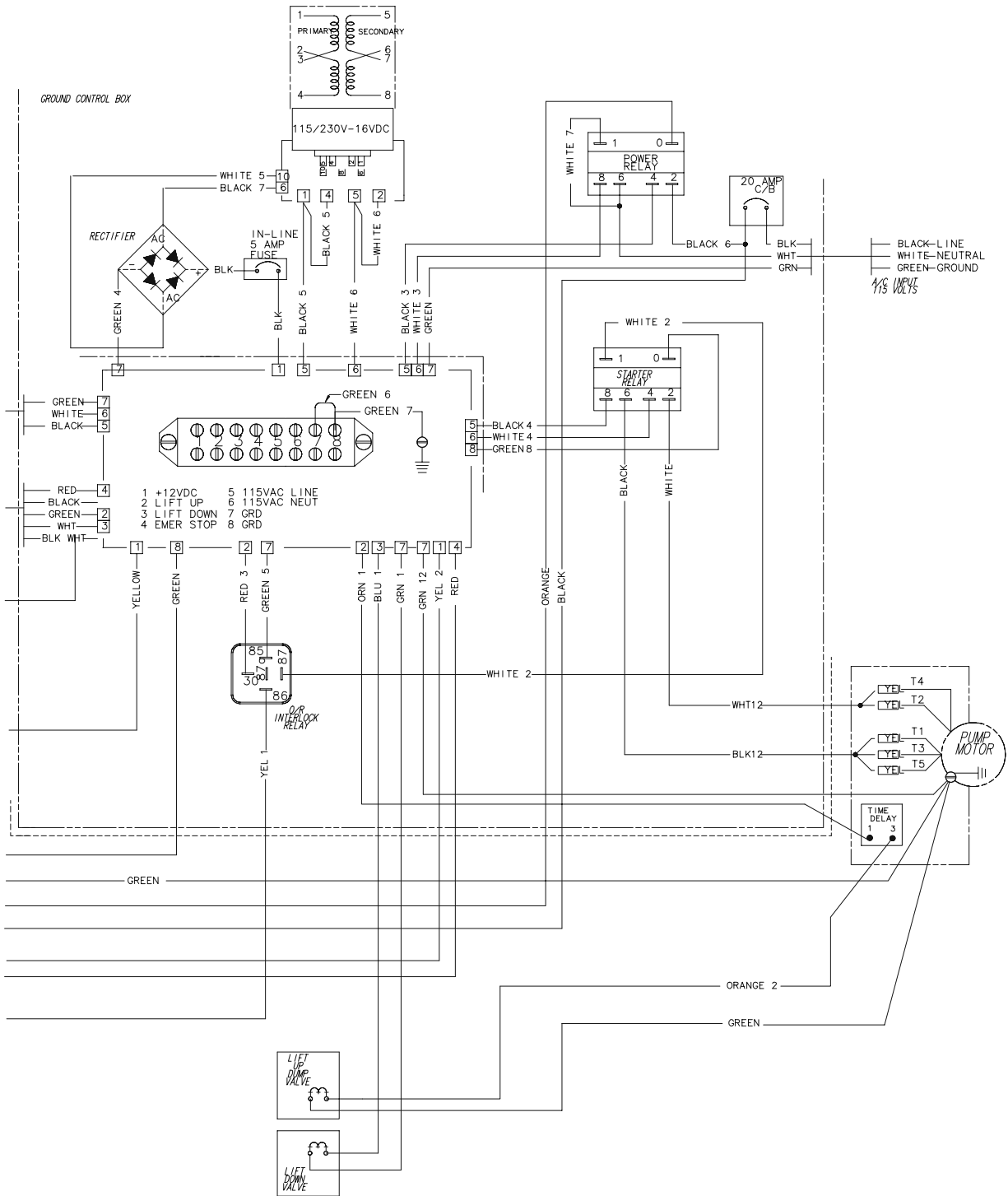

**SECTION 7 ELECTRICAL**

4933204 G

# SECTION 7 ELECTRICAL

## SECTION 7 ELECTRICAL

“THIS PAGE INTENTIONALLY LEFT BLANK”

# SECTION 8 DECALS

TABLE OF CONTENTS		
FIGURE	DESCRIPTION	PAGE
8-1	DECALS INSTALLATION .....	8-2

**S  
E  
C  
T  
I  
O  
N  
  
8  
  
D  
E  
C  
A  
L  
S**

# SECTION 8 DECALS

FIGURE 8-1.DECALS INSTALLATION

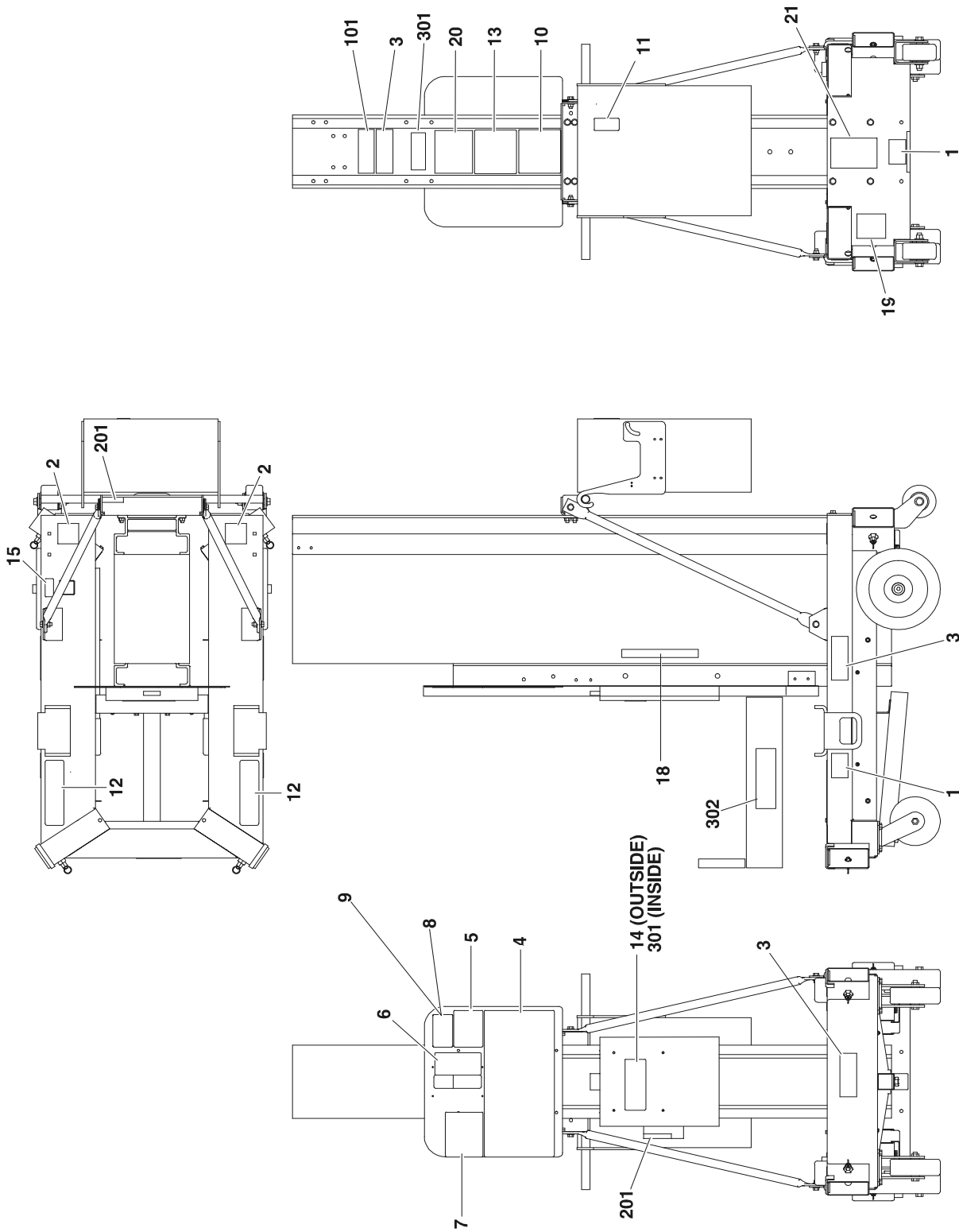

# SECTION 8 DECALS

**FIGURE 8-1. DECALS INSTALLATION**

FIG & ITEM #	PART NUMBER	DESCRIPTION	QTY.	REV.
	0258499	<b>DECAL INSTALLATION - U.S.A.</b>	Ref.	K
1	1702300	Decal - Tie Down	3	
2	1703073	Decal - Forklift	2	
3	1703681	Decal - JLG	4	
4	1703778**	Decal - Warning	1	
5	1703779**	Decal - USA	1	
6	1703780**	Decal - Controls	1	
7	1703781**	Decal - Electrical Hazard	1	
8	1703782**	Decal - Capacity (36EL/41EL Only)	1	
9	1703783**	Decal - Capacity (20EL/25EL/30EL Only)	1	
10	1703784*	Decal - Crushing/Tipping Hazard	1	
11	1703785*	Decal - Warning/ Fire Hazard	1	
12	1703786*	Decal - Crushing Hazard	2	
13	1703787*	Decal - Tiltback/ Crushing Hazard	1	
14	Use 1701509*	Decal - Manual (Prior to S/N 17519) (Was p/n 1703788)	1	
15	1703789*	Decal - Level Indicator	1	
16 to 17	Not Used			
18	1703815	Decal - Lanyard Attach	1	
19	Not Available	Decal - Barcode	1	
20	Not Available	Nameplate - Serial Number	1	
21	1700584	Decal - Patent (S/N 15050 to Present Only)	1	
	2901570	Decal Kit Options: (Includes Items with *asterisk)	1	
	2901657	Decal Kit Options: (Includes Items with **asterisk)	1	
101		<b>DECAL - MODEL DESIGNATION OPTIONS:</b>	Ref.	
	1704387	20EL	1	
	1704388	25EL	1	
	1704389	30EL	1	
	1704390	36EL	1	
	1704391	41EL	1	
	0258842	<b>DECAL 120V/60HZ INSTALLATION</b>	Ref.	A
201		Decal Options:		
	3251243	Decal - 120V/60HZ	2	
	0259457	<b>ELECTRIC LADDER DECAL INSTALLATION</b>	Ref.	A
301	1704393	Decal - JLG Service Support	2	
302	1704394	Decal - Electric Ladder Logo	2	

**SECTION 8 DECALS**

# SECTION 8 DECALS

FIGURE 8-1. DECALS INSTALLATION (CONTINUED)

FIG & ITEM #	PART NUMBER	DESCRIPTION	QTY.	REV.

**S  
E  
C  
T  
I  
O  
N  
  
8  
  
D  
E  
C  
A  
L  
S**

# SECTION 9 RECOMMENDED SERVICE PARTS STOCK

## EL SERIES

The following list will service fleets of machines (built to current production per date on the front cover) with emergency repair parts which can be installed in the field. Parts from the list should be replaced when inventory is depleted to keep service parts stock supplied. For further information, contact your JLG dealer or the JLG Industries Parts Department.

JLG PART NUMBER	DESCRIPTION	QTY PER FLEET		
		1-10	10-20	20 OR MORE
	<b>STANDARD PARTS</b>	Ref.	Ref.	Ref.
3740106	Relay, Potted (Figure 1-1)	1	1	1
4360467	Switch, Key (Figure 2-1 & 2-4)	1	1	1
2860030	Key Replacement (Figure 2-1 & 2-4)	1	1	1
7016714	Filler/Breather Assembly (Figure 2-3 & 2-7)	1	1	1
7020078	Switch, Push/Pull Stop (Figure 2-4)	1	1	1
7018586	Switch, Slide (Figure 2-6)	1	1	1
7020078	Switch, Push/Pull (Red) (Figure 2-8)	1	1	1
7020088	Switch, Push Button (White) (Figure 2-8)	1	1	1
7020089	Switch, Push Button (Green) (Figure 2-8)	1	1	1
2400006	Fuse 5-Amp (Figure 7-1)	2	2	2
	<b>VARIABLE PARTS</b>	Ref.	Ref.	Ref.
3740113	Relay, Timer (Figure 2-1 & 2-4)	1	1	1
3740093	Relay, Starter - AC Units (Figure 2-2)	1	1	1
3740094	Relay, Starter - 12VDC	1	1	1
4360161	Breaker, Circuit - 20 Amp (Figure 2-2)	1	1	1
4360376	Rectifier - AC Units (Figure 2-2)	1	1	1
3740049	Relay - AC Units (Figure 2-2)	1	1	1
4530013	Transformer - AC Units (Figure 2-2)	1	1	1
3740080	Relay - DC Units (Figure 2-4)	1	1	1
3740049	Solenoid - DC Units (Figure 2-4)	1	1	1
7011509	Breaker, Circuit - DC 50 Amp (Figure 2-6)	1	1	1
7018536	Breaker, Circuit - 3 Amp (Figure 2-6)	2	2	2
7013760	Solenoid - DC Units (Figure 2-7)	1	1	1

# SECTION 9 RECOMMENDED SERVICE PARTS

**SECTION 9 RECOMMENDED SERVICE PARTS STOCK**

## EL SERIES

The following list will service fleets of machines (built to current production per date on the front cover) with emergency repair parts which can be installed in the field. Parts from the list should be replaced when inventory is depleted to keep service parts stock supplied. For further information, contact your JLG dealer or the JLG Industries Parts Department.

JLG PART NUMBER	DESCRIPTION	QTY PER FLEET		
		1-10	10-20	20 OR MORE



# SECTION 10 SPECIAL OPTIONS

Note: This list is to accomodate machines ordered with special equipment. Options may not be applicable to all models. For more specific parts information contact JLG Parts Department.				
FIG & ITEM #	PART NUMBER	DESCRIPTION	QTY.	REV.
		<b>MISCELLANEOUS SPECIAL OPTIONS</b>	Ref.	
		<b>Special Tools:</b>	Ref.	
	7002821	Crimper (For Wire to Pin/Socket Connections)	1	
	7002823	Extractor (For Removal of Pin/Sockets Connectors)	1	
	4460467	Extractor 16-18 Gauge (For Wire to Pin/Socket from Deutsch Connectors)	1	
	4460510	Extractor 12-14 Gauge (For Wire to Pin/Socket from Deutsch Connectors)	1	
	7016654	Screwdriver, Magnetic	1	
	7004275	Seal Tool - 1"	1	
	7004276	Seal Tool - 1 1/2"	1	
	7002826	Seal Tool 2"	1	
	8896941	Stripper, Wire	1	

SECTION 10 SPECIAL OPTIONS

# SECTION 10 SPECIAL OPTIONS

## SECTION 10 SPECIAL OPTIONS

Note: This list is to accommodate machines ordered with special equipment. Options may not be applicable to all models. For more specific parts information contact JLG Parts Department.

FIG & ITEM #	PART NUMBER	DESCRIPTION	QTY.	REV.

# INDEX

P/N	PAGE	P/N	PAGE	P/N	PAGE	P/N	PAGE	P/N	PAGE
0100001	1-5	0258470	1-3	0270777	2-28	0400223	2-17	0641418	2-28
0100011	1-3	0258474	4-7	0270779	2-28	0400223	2-17	0641418	4-7
0100011	1-4	0258475	4-9	0270780	2-28	0561150	3-5	0641508	3-11
0100011	2-13	0258476	4-9	0270782	2-28	0561305	3-14	0641508	3-3
0100011	2-15	0258477	4-3	0270783	2-28	0561305	3-9	0641508	3-7
0100011	2-17	0258478	2-14	0270975	2-28	0561306	3-13	0641518	1-9
0100011	2-25	0258478	2-3	0270976	2-28	0561306	3-5	0641606	1-3
0100011	2-26	0258478	6-3	0270978	2-28	0561307	3-13	0641606	2-13
0100011	2-28	0258482	2-14	0270979	2-28	0561307	3-9	0641607	1-3
0100011	2-4	0258482	2-28	0270981	2-28	0561308	3-14	0641608	1-9
0100011	3-11	0258482	2-4	0270982	2-28	0561308	3-9	0641608	2-13
0100011	3-17	0258493	2-17	0270984	2-28	0561309	3-13	0641608	2-14
0100011	3-18	0258498	2-17	0270985	2-28	0561309	3-9	0641608	2-4
0100011	3-3	0258499	8-3	0270987	2-28	0561409	3-13	0641608	3-17
0100011	3-7	0258543	1-5	0270988	2-28	0561409	3-5	0641608	3-18
0100011	4-3	0258544	1-5	0271130	2-13	0630383	1-9	0641608	3-18
0100019	1-3	0258545	1-5	0271131	2-3	0630486	2-13	0641609	1-5
0100019	1-9	0258546	1-5	0271137	2-14	0630486	2-3	0641610	2-14
0100020	6-3	0258547	1-5	0271137	2-3	0641403	2-13	0641610	2-3
0100035	1-5	0258553	3-18	0271137	6-3	0641404	2-14	0641610	3-11
0100062	3-13	0258554	3-18	0271139	2-14	0641404	2-14	0641610	3-3
0100062	3-13	0258555	3-18	0271139	2-3	0641404	2-3	0641610	3-7
0100062	3-14	0258562	4-7	0271139	6-3	0641406	1-3	0641612	2-25
0100062	3-5	0258562	4-7	0271373	2-15	0641406	2-17	0641612	2-26
0100062	3-9	0258587	4-9	0271373	2-4	0641406	2-3	0641612	3-19
0100062	3-9	0258587	4-9	0271423	1-3	0641406	3-11	0641614	1-9
0140022	2-15	0258588	4-9	0271424	1-3	0641406	3-3	0641618	3-11
0140022	2-4	0258588	4-9	0271425	1-3	0641406	3-7	0641618	3-3
0255036	4-13	0258591	2-25	0271429	1-5	0641406	3-11	0641618	3-7
0255040	4-13	0258592	2-26	0271430	1-5	0641407	3-3	0641622	1-4
0255853	4-13	0258593	2-26	0271431	1-5	0641407	3-7	0641624	1-4
0256559	3-19	0258594	2-26	0271432	1-5	0641408	1-5	0641812	3-11
0257711	4-7	0258595	2-26	0271433	1-5	0641408	4-3	0641812	3-3
0257711	4-7	0258672	4-3	0362347	4-3	0641408	4-7	0641812	3-7
0258180	1-3	0258672	4-3	0362735	3-11	0641408	4-9	0641830	1-3
0258203	2-17	0258673	4-7	0362735	3-3	0641409	3-17	0681410	3-11
0258406	1-9	0258683	2-14	0362735	3-7	0641409	3-18	0681410	3-3
0258434	2-3	0258683	2-3	0362736	3-11	0641410	1-4	0681410	3-7
0258438	2-13	0258683	6-3	0362736	3-3	0641410	2-25	0681812	3-19
0258448	3-19	0258741	3-17	0362736	3-7	0641410	2-26	0720805	1-3
0258449	2-25	0258842	8-3	0362758	3-11	0641410	3-11	0720805	2-17
0258450	2-26	0258965	3-18	0362758	3-3	0641410	3-3	0721005	1-3
0258451	2-26	0259457	8-3	0362758	3-7	0641410	3-7	0721006	2-13
0258452	2-26	0270163	2-17	0400122	2-17	0641410	4-13	0721006	2-28
0258453	2-26	0270748	2-28	0400144	2-17	0641412	2-17	0721006	2-3
0258466	1-4	0270749	2-28	0400176	2-17	0641414	4-7	0721006	4-9
0258467	1-4	0270773	2-28	0400176	2-19	0641414	4-9	0721008	2-17
0258468	1-4	0270774	2-28	0400181	2-14	0641416	2-26	0721014	2-13
0258469	1-3	0270776	2-28	0400181	2-4	0641416	4-3	0721014	2-3

## INDEX

P/N	PAGE	P/N	PAGE	P/N	PAGE	P/N	PAGE	P/N	PAGE
0741606	3-11	0902431	3-3	1260329	3-3	1320149	2-27	1703787*	8-3
0741606	3-3	0902431	3-7	1260329	3-5	1320149	2-29	1703789*	8-3
0741606	3-7	0902442	2-17	1260330	3-11	1320215	1-9	1703815	8-3
0741618	3-11	0902445	3-11	1260330	3-13	1320218	4-13	1704277	3-19
0750802	4-13	0902445	3-3	1260331	3-11	1320224	2-14	1704387	8-3
0801141	3-3	0902445	3-7	1260331	3-13	1320238	2-25	1704388	8-3
0801142	3-7	0940049	1-9	1260331	3-7	1320238	2-27	1704389	8-3
0801143	3-11	0940085	2-17	1260331	3-9	1380132	4-13	1704390	8-3
0801144	3-7	0961845	4-7	1260332	3-11	1670603	2-27	1704391	8-3
0801145	3-11	0961892	3-11	1260332	3-13	1683693	3-8	1704393	8-3
0801291	3-3	0961892	3-17	1260332	3-7	1683693	5-3	1704394	8-3
0801292	3-7	0961892	3-18	1260332	3-9	1683699	3-12	1704582	1-5
0801293	3-11	0961892	3-3	1260333	3-11	1683699	3-3	1704582	2-14
0801294	3-7	0961892	3-7	1260333	3-14	1683699	3-8	1704582	2-4
0801295	3-11	0962195	1-9	1260333	3-7	1683699	5-3	1706326	4-13
0840946	2-28	0962196	1-9	1260333	3-9	1683700	3-12	1846514	3-13
0860520	4-3	0962197	1-9	1260334	3-11	1683700	5-3	2220473	6-3
0860520	4-7	1060380	1-9	1260334	3-14	1684086	3-12	2220507	6-3
0860520	4-9	1060380	4-13	1260334	3-7	1684086	5-5	2220603	6-3
0860911	2-7	1060380	4-13	1260334	3-9	1684087	3-8	2220773	6-3
0860933	2-3	1060380	4-3	1271389	3-11	1684087	5-5	2220775	6-3
0860933	2-7	1060380	4-7	1271389	3-3	1684088	3-12	2220875	6-3
0860943	2-7	1060380	4-9	1271389	3-7	1684088	3-3	2400006	7-2
0860945	2-26	1060518	2-13	1271390	3-11	1684088	3-8	2400006	7-2
0860947	4-13	1060548	3-11	1271390	3-3	1684088	5-5	2400006	9-1
0861192	2-17	1060564	2-28	1271390	3-7	1700584	8-3	2420140	1-5
0861193	2-17	1060565	2-29	1271391	3-12	1702120	2-7	2420195	2-17
0861207	2-25	1060570	2-17	1271391	3-3	1702300	8-3	2540025	1-3
0861207	2-26	1060571	2-13	1271391	3-7	1702353	2-14	2560088	1-3
0861212	2-13	1060655	3-11	1271392	3-12	1702353	2-4	2560088	1-5
0861212	2-3	1060655	3-7	1271392	3-3	1702365	2-7	2560088	1-9
0861213	2-14	1060683	3-11	1271392	3-8	1702365	4-13	2560088	3-17
0861213	2-4	1060683	3-3	1271393	3-12	1702365	4-13	2560127	1-4
0861305	2-13	1060683	3-7	1271393	3-3	1702569	2-7	2600225	4-9
0861305	2-3	1060684	3-11	1271393	3-8	1702612	3-19	2700092	3-17
0902047	3-11	1060684	3-7	1271394	3-11	1703073	8-3	2700092	3-18
0902047	3-3	1060685	3-11	1271394	3-7	1703455	3-19	2720130	3-17
0902047	3-7	1060685	3-3	1271395	3-12	1703681	4-7	2720130	3-18
0902054	2-13	1060685	3-7	1271395	3-7	1703681	4-9	2820086	1-4
0902079	4-13	1060687	2-25	1271396	3-12	1703681	8-3	2840019	1-4
0902422	3-11	1060687	2-25	1271396	3-7	1703778**	8-3	2860030	2-13
0902422	3-7	1060687	2-26	1271397	3-12	1703779**	8-3	2860030	2-3
0902423	3-11	1060694	2-27	1271397	3-8	1703780**	8-3	2860030	9-1
0902423	3-3	1060696	3-3	1271398	3-12	1703781**	8-3	2880310	3-12
0902423	3-7	1060925	2-28	1271398	3-8	1703782**	8-3	2880310	3-3
0902424	3-11	1220015	1-4	1271399	3-12	1703783**	8-3	2880310	3-8
0902424	3-3	1260299	3-5	1271399	3-8	1703784*	8-3	2901570	8-3
0902424	3-7	1260329	3-11	1320043	1-3	1703785*	8-3	2901603	3-4
0902431	3-11	1260329	3-13	1320149	2-25	1703786*	8-3	2901604	3-9

# INDEX

P/N	PAGE	P/N	PAGE	P/N	PAGE	P/N	PAGE	P/N	PAGE
2901605	3-13	3311405	4-3	3340858	3-3	3570893	3-3	3740093	2-7
2901606	3-9	3311405	4-7	3340858	3-8	3570893	3-8	3740093	9-1
2901607	3-13	3311405	4-7	3420934	1-9	3570923	2-25	3740094	2-7
2901657	8-3	3311405	4-9	3421453	4-13	3570923	2-27	3740094	9-1
2920127	4-13	3311405	4-9	3421453	4-13	3570927	1-9	3740106	1-3
2920151	1-3	3311501	1-9	3422265	3-13	3570946	1-3	3740106	7-2
2940074	4-9	3311501	2-17	3422265	3-5	3570947	1-3	3740106	9-1
2940082	4-3	3311505	1-9	3422369	1-3	3570949	1-9	3740113	2-13
2940111	2-17	3311505	2-13	3422369	1-9	3570971	1-5	3740113	2-3
3020017	1-4	3311505	2-17	3422370	1-9	3570973	1-3	3740113	9-1
3020022	1-3	3311505	2-3	3422657	4-3	3570976	3-19	3760170	4-13
3020035	1-4	3311505	3-12	3422657	4-7	3570986	4-7	3760170	4-13
3251243	8-3	3311505	3-3	3422657	4-9	3571150	1-4	3780200	1-5
3252760	2-29	3311505	3-8	3422717	3-12	3572370	1-9	3820001	2-17
3252761	2-29	3311505	4-3	3422717	3-3	3580217	3-12	3820006	3-12
3271805	3-19	3311505	4-9	3422717	3-8	3580217	3-4	3820006	3-4
3300151	4-3	3311601	3-12	3422720	3-14	3580217	3-8	3820006	3-8
3300356	4-10	3311601	3-3	3422720	3-9	3580231	2-25	3820024	1-9
3300379	1-3	3311601	3-8	3422721	3-13	3580231	2-27	3820024	4-3
3300380	1-4	3311605	1-3	3422721	3-9	3580268	3-12	3820024	4-4
3300391	4-13	3311605	1-4	3422722	3-14	3580268	3-4	3820024	4-7
3300392	1-4	3311605	1-5	3422722	3-9	3580268	3-8	3820024	4-9
3310405	1-3	3311605	1-9	3422744	1-3	3580269	3-12	3820032	2-25
3310805	1-3	3311605	2-14	3422744	1-9	3580269	3-4	3820032	2-27
3310805	2-17	3311605	2-25	3422744	3-17	3580269	3-8	3820032	3-17
3311001	2-29	3311605	2-27	3422744	3-18	3580272	3-13	3820032	3-18
3311001	4-3	3311605	2-4	3450201	3-13	3580272	3-9	3820034	3-12
3311005	1-3	3311605	3-12	3450201	3-5	3580286	3-12	3820034	3-4
3311005	2-13	3311605	3-17	3450202	3-14	3580286	3-4	3820034	3-8
3311005	2-17	3311605	3-18	3450202	3-14	3580286	3-8	3900032	4-9
3311005	2-3	3311605	3-19	3450202	3-9	3600273	2-13	3900111	1-9
3311005	4-10	3311605	3-19	3450202	3-9	3600273	2-21	3900177	4-3
3311005	4-3	3311605	3-3	3450504	3-17	3600281	2-3	3900187	3-12
3311401	2-17	3311605	3-8	3450504	3-18	3600281	2-9	3900187	3-4
3311401	3-12	3311801	3-12	3510676	4-3	3600292	2-3	3900187	3-8
3311401	3-3	3311801	3-8	3520028	2-7	3600292	2-9	3900190	2-17
3311401	3-8	3311805	1-3	3520028	4-3	3600320	2-13	3900190	3-12
3311405	1-3	3312002	1-3	3520034	2-27	3600320	2-21	3900190	3-17
3311405	1-4	3321701	3-17	3520034	2-7	3600322	2-3	3900190	3-18
3311405	1-5	3321701	3-18	3520072	4-3	3600322	2-9	3900190	3-4
3311405	2-17	3340712	1-4	3520072	4-9	3640924	4-3	3900190	3-8
3311405	2-25	3340746	4-3	3520163	1-9	3640990	4-3	3900191	2-25
3311405	2-27	3340754	4-3	3520163	3-17	3740013	2-13	3900191	2-27
3311405	2-3	3340845	3-12	3520169	4-7	3740049	2-13	3900192	3-12
3311405	3-12	3340845	3-17	3539814	3-19	3740049	2-7	3900192	3-4
3311405	3-3	3340845	3-18	3570435	4-7	3740049	9-1	3900192	3-8
3311405	3-8	3340845	3-3	3570462	4-9	3740049	9-1	3900193	1-5
3311405	4-13	3340845	3-8	3570464	4-9	3740080	2-13	3900194	1-3
3311405	4-3	3340858	3-12	3570893	3-12	3740080	9-1	3900200	2-25

## INDEX

P/N	PAGE	P/N	PAGE	P/N	PAGE	P/N	PAGE	P/N	PAGE
3900200	.....2-27	4070861	.....3-9	4360376	.....2-7	4460566	.....2-25	4711600	.....1-9
3900202	.....4-3	4070862	.....3-13	4360376	.....9-1	4460566	.....2-27	4711600	.....2-14
3900203	.....4-3	4070862	.....3-17	4360467	.....2-13	4460566	.....2-3	4711600	.....2-25
3900204	.....4-13	4070862	.....3-18	4360467	.....2-3	4460633	.....2-7	4711600	.....2-27
3900205	.....3-12	4070862	.....3-4	4360467	.....9-1	4530013	.....2-7	4711600	.....2-4
3900205	.....3-4	4070862	.....3-9	4420039	.....4-7	4530013	.....9-1	4711600	.....3-17
3900205	.....3-8	4070890	.....4-3	4420039	.....4-9	4566847	.....4-13	4711600	.....3-18
3900206	.....3-12	4070894	.....4-4	4420064	.....2-14	4567489	.....3-12	4711600	.....3-19
3900206	.....3-4	4070970	.....3-12	4420064	.....2-4	4567489	.....3-4	4711600	.....3-19
3900206	.....3-8	4070970	.....3-4	4420065	.....2-14	4567489	.....3-8	4711600	.....3-8
3900212	.....1-3	4070970	.....3-8	4420065	.....2-4	4567490	.....3-12	4711600	.....4-9
3900255	.....1-3	4070971	.....3-12	4460018	.....2-28	4567491	.....3-12	4711700	.....3-17
3900258	.....4-9	4070971	.....3-4	4460023	.....2-27	4567491	.....3-8	4711700	.....3-18
3910808	.....2-7	4070971	.....3-8	4460023	.....2-29	4567492	.....3-13	4711800	.....1-3
3911032	.....4-3	4070981	.....3-18	4460035	.....2-27	4567492	.....3-4	4711800	.....3-13
3931516	.....2-21	4070984	.....2-14	4460035	.....2-27	4567492	.....3-8	4711800	.....3-4
3941004	.....1-9	4070984	.....2-4	4460035	.....2-29	4567508	.....1-5	4711800	.....3-8
3941405	.....1-3	4070988	.....3-13	4460044	.....7-2	4567599	.....1-9	4712200	.....3-17
3990010	.....7-2	4070988	.....3-4	4460044	.....7-2	4567601	.....1-5	4712200	.....3-18
3990010	.....7-2	4070988	.....3-9	4460115	.....2-25	4567602	.....1-5	4712600	.....3-13
3990010	.....7-2	4070989	.....3-13	4460115	.....2-25	4567603	.....1-5	4712600	.....3-4
4060092	.....2-25	4070989	.....3-4	4460115	.....2-26	4567605	.....2-13	4712600	.....3-9
4060092	.....2-27	4070989	.....3-9	4460115	.....2-27	4567635	.....3-4	4740007	.....3-4
4060092	.....2-29	4070990	.....3-13	4460115	.....2-27	4567669	.....6-3	4740414	.....3-13
4060803	.....4-10	4070990	.....3-4	4460121	.....2-29	4567670	.....6-3	4740414	.....3-4
4060803	.....4-3	4070990	.....3-9	4460145	.....2-25	4568227	.....6-3	4740414	.....3-9
4060803	.....4-7	4160124	.....3-12	4460145	.....2-26	4568228	.....6-3	4740426	.....2-25
4060804	.....4-3	4160124	.....3-4	4460145	.....2-27	4568433	.....1-5	4740426	.....2-27
4060807	.....1-9	4160124	.....3-8	4460145	.....2-27	4640900	.....6-3	4740428	.....4-3
4060875	.....2-14	4160125	.....4-3	4460145	.....2-29	4711400	.....2-13	4740429	.....4-3
4060875	.....2-4	4160130	.....2-25	4460145	.....2-29	4711400	.....2-14	4740434	.....1-4
4060882	.....4-3	4160130	.....2-27	4460190	.....2-25	4711400	.....2-25	4740434	.....1-5
4060960	.....3-12	4160165	.....4-9	4460190	.....2-27	4711400	.....2-27	4750800	.....1-4
4060960	.....3-4	4160173	.....1-9	4460190	.....2-29	4711400	.....2-4	4750800	.....2-17
4060960	.....3-8	4240032	.....1-4	4460234	.....1-3	4711400	.....3-13	4750800	.....3-13
4060961	.....3-12	4240033	.....2-29	4460267	.....2-14	4711400	.....3-4	4750800	.....3-4
4060961	.....3-4	4280291	.....1-5	4460267	.....2-4	4711400	.....3-8	4750800	.....3-9
4060961	.....3-8	4280296	.....4-13	4460268	.....7-2	4711400	.....4-3	4751000	.....1-4
4061024	.....2-14	4280296	.....4-13	4460268	.....7-2	4711400	.....4-7	4751000	.....2-13
4061024	.....2-4	4280296	.....4-7	4460315	.....2-28	4711400	.....4-7	4751000	.....2-17
4070860	.....3-13	4300111	.....3-13	4460320	.....2-14	4711400	.....4-9	4751000	.....2-26
4070860	.....3-17	4300111	.....3-14	4460320	.....2-4	4711400	.....4-9	4751000	.....2-27
4070860	.....3-18	4300111	.....3-5	4460424	.....7-2	4711500	.....1-9	4751000	.....2-3
4070860	.....3-4	4300111	.....3-9	4460424	.....7-2	4711500	.....3-13	4751000	.....4-3
4070860	.....3-9	4300129	.....3-14	4460425	.....4-13	4711500	.....3-4	4751400	.....1-5
4070861	.....3-13	4300129	.....3-9	4460467	.....10-1	4711500	.....3-8	4751400	.....1-5
4070861	.....3-17	4360161	.....2-7	4460510	.....10-1	4711500	.....4-3	4751400	.....2-13
4070861	.....3-18	4360161	.....9-1	4460549	.....2-29	4711600	.....1-3	4751400	.....2-17
4070861	.....3-4	4360274	.....2-28	4460565	.....2-7	4711600	.....1-5	4751400	.....2-3

# INDEX

P/N	PAGE	P/N	PAGE	P/N	PAGE	P/N	PAGE	P/N	PAGE
4751400	3-17	4845805	4-9	4923069	2-28	7013717	2-21	7016751	2-21
4751400	3-18	4845808	4-9	4923070	2-25	7013717	2-9	7016753	2-10
4751400	4-3	4845809	4-9	4923071	2-28	7013720	2-10	7016753	2-21
4751500	2-13	4845813	4-9	4923073	2-28	7013720	2-21	7016755	2-10
4751500	2-17	4845821	4-3	4923075	2-26	7013722	2-21	7016755	2-22
4751500	2-26	4845821	4-7	4923076	2-26	7013722	2-9	7016757	2-9
4751500	2-27	4845821	4-9	4923077	2-28	7013726	2-10	7016758	2-9
4751500	2-3	4845822	4-3	4923079	2-28	7013728	2-21	7016759	2-10
4751600	1-5	4845831	4-3	4923081	2-26	7013728	2-9	7016759	2-21
4751600	2-13	4845868	3-17	4923082	2-26	7013733	2-10	7016764	2-9
4751600	2-14	4845869	3-17	4923083	2-28	7013733	2-21	7016770	2-21
4751600	2-4	4845869	3-18	4923085	2-28	7013743	2-10	7016770	2-9
4751600	3-13	4845945	3-18	4923087	2-26	7013743	2-21	7016771	2-21
4751600	3-4	4845946	3-18	4923088	2-26	7013747	2-10	7016771	2-9
4751600	3-9	4846381	3-13	4923089	2-28	7013747	2-21	7016772	2-21
4751800	3-19	4846381	3-4	4923091	2-28	7013754	2-21	7016773	2-21
4752600	3-4	4846381	3-9	4923093	2-26	7013758	2-21	7016773	2-9
4761000	2-29	4846388	1-4	4923094	2-26	7013760	2-21	7016774	2-9
4761000	3-13	4846514	3-4	4933036	7-2	7013760	9-1	7016775	2-10
4761000	3-4	4846514	3-9	4933037	7-2	7013764	2-10	7016775	2-21
4761000	3-9	4851000	4-9	4933186	7-2	7013764	2-21	7016776	2-10
4761400	3-13	4860143	1-9	4933203*	7-2	7013766	2-21	7016776	2-21
4761400	3-4	4860183	1-4	4933204*	7-2	7013768	2-22	7016787	2-9
4761400	3-9	4860184	1-6	7002821	10-1	7013770	2-10	7016787	2-9
4761500	3-13	4860185	1-4	7002823	10-1	7013770	2-22	7016793	2-9
4761500	3-4	4860185	3-17	7002826	10-1	7013779	2-10	7018536	2-19
4761500	3-9	4860185	3-18	7003246	5-3	7013779	2-21	7018536	9-1
4761600	3-13	4860186	3-17	7004275	10-1	7013787	2-9	7018555	2-19
4844840	4-13	4860196	3-17	7004276	10-1	7013792	2-10	7018556	2-19
4845345	3-19	4860196	3-18	7011509	2-19	7013792	2-21	7018586	2-19
4845577	4-7	4860245	1-6	7011509	9-1	7013793	2-10	7018586	9-1
4845578	4-7	4860246	1-4	7011528	2-19	7013793	2-21	7019833	5-3
4845705	1-4	4860247	1-4	7012630	1-6	7013795	2-21	7019834	5-3
4845706	1-9	4891800	1-5	7012631	1-4	7013795	2-9	7019835	5-3
4845706	3-17	4921661	7-2	7012631	1-4	7016339	2-13	7019836	5-3
4845712	2-3	4921663	2-7	7012631	1-6	7016339	2-3	7019837	5-3
4845714	2-13	4922412	7-2	7012631	3-17	7016654	10-1	7019838	5-3
4845715	1-5	4922420	2-26	7012631	3-18	7016713	2-21	7019839	5-3
4845717	3-19	4922420	2-27	7013708	2-21	7016713	2-9	7019840	5-3
4845727	3-17	4922420	7-2	7013708	2-9	7016714	2-10	7020017	1-6
4845728	3-19	4922421	7-2	7013710	2-21	7016714	2-21	7020032	2-19
4845731	3-13	4922546	7-2	7013713	2-21	7016714	9-1	7020078	2-13
4845731	3-4	4922583	2-15	7013713	2-9	7016720	2-21	7020078	2-25
4845731	3-9	4922583	2-4	7013714	2-21	7016720	2-9	7020078	2-26
4845762	1-9	4922605	2-14	7013714	2-9	7016721	2-21	7020078	2-3
4845763	1-5	4922605	7-2	7013715	2-21	7016721	2-9	7020078	9-1
4845795	3-4	4922605	7-2	7013715	2-9	7016735	2-21	7020083	1-4
4845796	4-7	4922657	2-25	7013716	2-21	7016735	2-9	7020084	1-4
4845797	4-7	4922740	2-14	7013716	2-9	7016751	2-10	7020084	1-4

# INDEX

P/N	PAGE	P/N	PAGE
7020084	1-6	7023396	5-5
7020084	3-17	7023397	5-5
7020084	3-17	7023398	5-5
7020084	3-18	7023399	5-5
7020084	3-18	7024352	5-5
7020086	1-6	7024353	5-5
7020087	1-4	8896941	10-1
7020087	3-17	9984088	2-14
7020087	3-18	9984088	2-4
7020088	2-25	AM-P2117	3-17
7020088	2-26	AM-P2117	3-18
7020088	9-1	AN960-T16L-1	3-17
7020089	2-25	AN960-T16L-1	3-18
7020089	2-26	AN960-T16L-2	3-17
7020089	9-1	AN960-T16L-2	3-18
7020090	2-13	APL-P117	3-17
7020090	2-3	APL-P117	3-18
7020091	2-25	BB6-CF-1-S	3-17
7020091	2-26	BB6-CF-1-S	3-18
7020093	2-13		
7020093	2-25		
7020093	2-26		
7020093	2-3		
7020094	2-13		
7020094	2-3		
7020095	9-1		
7020096	2-13		
7020096	2-3		
7020097	2-13		
7020097	2-3		
7020098	2-13		
7020098	2-3		
7020605	2-19		
7020626	2-19		
7020627	2-19		
7020629	2-19		
7020631	2-19		
7020633	2-19		
7022204	2-21		
7022217	2-9		
7022219	2-10		
7022220	2-10		
7022221	2-10		
7022222	2-9		
7023391	5-5		
7023392	5-5		
7023393	5-5		
7023394	5-5		
7023395	5-5		







Corporate Office  
JLG Industries, Inc.  
1 JLG Drive  
McConnellsburg PA. 17233-9533  
USA  
Phone: (717) 485-5161  
Fax: (717) 485-6417

## JLG Worldwide Locations

---

JLG Industries (Australia)  
P.O. Box 5119  
11 Bolwarra Road  
Port Macquarie  
N.S.W. 2444  
Australia  
Phone: (61) 2 65 811111  
Fax: (61) 2 65 810122

JLG Industries (UK)  
Unit 12, Southside  
Bredbury Park Industrial Estate  
Bredbury  
Stockport  
SK6 2sP  
England  
Phone: (44) 870 200 7700  
Fax: (44) 870 200 7711

JLG Deutschland GmbH  
Max Planck Strasse 21  
D-27721 Ritterhude/Idpohl  
Bei Bremen  
Germany  
Phone: (49) 421 693 500  
Fax: (49) 421 693 5035

JLG Industries (Italia)  
Via Po. 22  
20010 Pregnana Milanese - MI  
Italy  
Phone: (39) 02 9359 5210  
Fax: (39) 02 9359 5845

JLG Latino Americana Ltda.  
Rua Eng. Carlos Stevenson,  
80-Suite 71  
13092-310 Campinas-SP  
Brazil  
Phone: (55) 19 3295 0407  
Fax: (55) 19 3295 1025

JLG Europe B.V.  
Jupiterstraat 234  
2132 HJ Foofddorp  
The Netherlands  
Phone: (31) 23 565 5665  
Fax: (31) 23 557 2493

JLG Industries (Norge AS)  
Sofeimyrveien 12  
N-1412 Sofienyr  
Norway  
Phone: (47) 6682 2000  
Fax: (47) 6682 2001

JLG Polska  
Ul. Krolewska  
00-060 Warszawa  
Poland  
Phone: (48) 91 4320 245  
Fax: (48) 91 4358 200

JLG Industries (Europe)  
Kilmartin Place,  
Tannochside Park  
Uddingston G71 5PH  
Scotland  
Phone: (44) 1 698 811005  
Fax: (44) 1 698 811055

JLG Industries (Pty) Ltd.  
Unit 1, 24 Industrial Complex  
Herman Street  
Meadowdale  
Germiston  
South Africa  
Phone: (27) 11 453 1334  
Fax: (27) 11 453 1342

Plataformas Elevadoras  
JLG Iberica, S.L.  
Trapadella, 2  
P.I. Castellbisbal Sur  
08755Castellbisbal  
Spain  
Phone: (34) 93 77 24700  
Fax: (34) 93 77 11762

JLG Industries (Sweden)  
Enkopingsvagen 150  
Box 704  
SE - 175 27 Jarfalla  
Sweden  
Phone: (46) 8 506 59500  
Fax: (46) 8 506 59534

---