



**Operation & Safety,
Service & Maintenance, &
Illustrated Parts Manual Supplement**

**JLG
LOAD
SENSING
SYSTEM**

Scissors Lift Products

**P/N
3124288**

July 26, 2013

ANSI

CE



An Oshkosh Corporation Company

SECTION A. INTRODUCTION - MAINTENANCE SAFETY PRECAUTIONS

A GENERAL

This section contains the general safety precautions which must be observed during maintenance of the aerial platform. It is of utmost importance that maintenance personnel pay strict attention to these warnings and precautions to avoid possible injury to themselves or others, or damage to the equipment. A maintenance program must be followed to ensure that the machine is safe to operate.

⚠ WARNING

MODIFICATION OF THE MACHINE WITHOUT CERTIFICATION BY A RESPONSIBLE AUTHORITY THAT THE MACHINE IS AT LEAST AS SAFE AS ORIGINALLY MANUFACTURED, IS A SAFETY VIOLATION.

The specific precautions to be observed during maintenance are inserted at the appropriate point in the manual. These precautions are, for the most part, those that apply when servicing hydraulic and larger machine component parts.

Your safety, and that of others, is the first consideration when engaging in the maintenance of equipment. Always be conscious of weight. Never attempt to move heavy parts without the aid of a mechanical device. Do not allow heavy objects to rest in an unstable position. When raising a portion of the equipment, ensure that adequate support is provided.

⚠ WARNING

SINCE THE MACHINE MANUFACTURER HAS NO DIRECT CONTROL OVER THE FIELD INSPECTION AND MAINTENANCE, SAFETY IN THIS AREA IS THE RESPONSIBILITY OF THE OWNER/OPERATOR.

B HYDRAULIC SYSTEM SAFETY

It should be noted that the machines hydraulic systems operate at extremely high, potentially dangerous pressures. Every effort should be made to relieve any system pressure prior to disconnecting or removing any portion of the system.

C MAINTENANCE

⚠ WARNING

FAILURE TO COMPLY WITH SAFETY PRECAUTIONS LISTED IN THIS SECTION MAY RESULT IN MACHINE DAMAGE, PERSONNEL INJURY OR DEATH AND IS A SAFETY VIOLATION.

- REMOVE ALL RINGS, WATCHES AND JEWELRY WHEN PERFORMING ANY MAINTENANCE.
- DO NOT WEAR LONG HAIR UNRESTRAINED, OR LOOSE-FITTING CLOTHING AND NECKTIES WHICH ARE APT TO BECOME CAUGHT ON OR ENTANGLED IN EQUIPMENT.
- OBSERVE AND OBEY ALL WARNINGS AND CAUTIONS ON MACHINE AND IN SERVICEMANUAL.
- KEEP OIL, GREASE, WATER, ETC. WIPED FROM STANDING SURFACES AND HAND HOLDS.
- NEVER WORK UNDER AN ELEVATED SIZZOR UNTIL PLATFORM HAS BEEN SAFELY RESTRAINED FROM ANY MOVEMENT BY BLOCKING OR OVERHEAD SLING, OR BOOM SAFETY PROP HAS BEEN ENGAGED.
- BEFORE MAKING ADJUSTMENTS, LUBRICATING OR PERFORMING ANY OTHER MAINTENANCE, SHUT OFF ALL POWER CONTROLS.
- BATTERY SHOULD ALWAYS BE DISCONNECTED DURING REPLACEMENT OF ELECTRICAL COMPONENTS.
- KEEP ALL SUPPORT EQUIPMENT AND ATTACHMENTS STOWED IN THEIR PROPER PLACE.
- USE ONLY APPROVED, NONFLAMMABLE CLEANING SOLVENTS.

REVISION LOG

| | | |
|----------------|---|--------------------|
| Original Issue | - | June 13, 2003 |
| Revised | - | July 28, 2003 |
| Revised | - | August 11, 2003 |
| Revised | - | September 12, 2003 |
| Revised | - | March 1, 2004 |
| Revised | - | October 15, 2004 |
| Revised | - | July 15, 2006 |
| Revised | - | October 26, 2007 |
| Revised | - | June 4, 2010 |
| Revised | - | March 31, 2011 |
| Revised | - | March 1, 2012 |
| Revised | - | August 11, 2012 |
| Revised | - | January 30, 2013 |
| Revised | - | July 26, 2013 |

TABLE OF CONTENTS

| SUBJECT - SECTION, PARAGRAPH | PAGE NO. |
|---|-----------------|
| SECTION A - INTRODUCTION - MAINTENANCE SAFETY PRECAUTIONS | |
| A General | A-1 |
| B Hydraulic System Safety | A-1 |
| C Maintenance | A-1 |
| SECTION 1 - ANALYZER OPERATION - ALL | |
| 1.1 Introduction & Operation | 1-1 |
| 1.2 Using the Analyzer | 1-1 |
| 1.3 Changing the Access Level of the Hand Held Analyzer | 1-2 |
| 1.4 Viewing & Adjusting Parameters Using the Hand Held Analyzer | 1-3 |
| SECTION 2 - OPERATION - (LE, MRT, RTS) | |
| 2.1 Connecting the JLG Control System Analyzer (LE, MRT & RTS) | 2-1 |
| 2.2 Help Menu & Fault Codes (LE, MRT & RTS) | 2-1 |
| 2.3 Diagnostic Menu (LE, MRT & RTS) | 2-3 |
| 2.4 Personalities (LE, MRT & RTS) | 2-5 |
| 2.5 Machine Setup Menu (LE, MRT & RTS) | 2-6 |
| 2.6 Calibration Menu (LE, MRT & RTS) | 2-6 |
| 2.7 JLG Workstation in the Sky™ Accessories | 2-9 |
| SECTION 3 - OPERATION - (ES, RT) | |
| 3.1 Connecting the JLG Control System Analyzer (ES & RT) | 3-1 |
| 3.2 Help Menu & Fault Codes (ES & RT) | 3-1 |
| 3.3 Diagnostic Menu (ES & RT) | 3-3 |
| 3.4 Personalities (ES & RT) | 3-3 |
| 3.5 Machine Setup Menu (ES & RT) | 3-4 |
| 3.6 Calibration Menu (ES & RT) | 3-4 |
| SECTION 4 - OPERATION - (RS) | |
| 4.1 Connecting the JLG Control System Analyzer (RS) | 4-1 |
| 4.2 Help Menu & Fault Codes (RS) | 4-1 |
| 4.3 Diagnostic Menu (RS) | 4-2 |
| 4.4 Personalities MENU (RS) | 4-3 |
| 4.5 Calibration Menu (RS) | 4-3 |
| Angle Sensor Calibration (RS Only) | 4-3 |
| 4.6 Load Sensing System Calibration (RS Only) | 4-5 |
| SECTION 5 - SERVICE - (LE, MRT, RTS, ES, RT) | |
| 5.1 Description | 5-1 |
| 5.2 Calibration | 5-2 |
| Procedure | 5-2 |
| Testing & Evaluation | 5-2 |
| 5.3 Troubleshooting | 5-4 |
| SECTION 6 - SERVICE - (RS) | |
| 6.1 Description (RS) | 6-1 |
| 6.2 Calibration (RS) | 6-1 |
| Angle Sensor Calibration Procedure (RS) | 6-1 |
| Platform Load Sensing System Calibration Procedure (RS) | 6-1 |
| 6.3 Testing and Evaluation (RS) | 6-2 |
| 6.4 LSS Troubleshooting (RS) | 6-3 |
| 6.5 LSS Component Removal/Installation (RS) | 6-5 |
| Pressure Transducer Removal (RS) | 6-5 |
| Pressure Transducer Installation (RS) | 6-5 |

TABLE OF CONTENTS (Continued)

| | |
|---|-----|
| 10RS Angle Sensor Removal (RS) | 6-6 |
| 10RS Angle Sensor Installation (RS) | 6-6 |
| 6RS Angle Sensor Removal (RS) | 6-6 |
| 6RS Angle Sensor Installation (RS) | 6-6 |
| LSS Connector Pin Assignments (RS) | 6-7 |

SECTION 7 - PARTS

| | | |
|-----|--|------|
| 7-1 | Load Sensing System Installation (260MRT, M3369/M4069 & 3369LE/4069LE) | 7-2 |
| 7-2 | Load Sensing System Installation (500RTS) | 7-6 |
| 7-3 | Load Sensing System Installation (1930ES/2032ES/2630ES/ 2646ES/3246ES) | 7-8 |
| 7-4 | Load Sensing System Installation (6RS/10RS/1932RS/3248RS) | 7-12 |
| 7-5 | Load Sensing System Installation (3394RT/4394RT) | 7-14 |

LIST OF FIGURES

| FIGURE NO. | TITLE | PAGE NO. |
|------------|--|----------|
| 2-1. | Module Analyzer Flow Chart | 2-8 |
| 3-1. | Module Analyzer Flow Chart | 3-6 |
| 5-1. | Load Sense Module | 5-1 |
| 5-2. | LSS Module Load Cell Connector Pinout (J5, J6, J7, J8) | 5-10 |
| 5-3. | 260MRT Wiring Diagram | 5-11 |
| 5-4. | M3369/M4069 & 3369LE/4069LE Wiring Diagram | 5-12 |
| 5-5. | 500RTS Wiring Diagram | 5-13 |
| 5-6. | ES Wiring Diagram | 5-14 |
| 5-7. | RT Wiring Diagram | 5-15 |
| 6-1. | LSS Pressure Transducers Location - 1932RS/6RS | 6-5 |
| 6-2. | LSS Pressure Transducers Location - 3248RS/10RS | 6-5 |
| 6-3. | LSS - Scissor Arm Angle Sensor - (RS) | 6-6 |
| 6-4. | LSS - Electrical Component Schematic - (RS) | 6-8 |

LIST OF TABLES

| TABLE NO. | TITLE | PAGE NO. |
|-----------|--|----------|
| 2-1 | LSS Fault Codes (LE, MRT and RTS) | 2-1 |
| 2-2 | Diagnostic Menu Descriptions (LE, MRT & RTS) | 2-3 |
| 2-3 | Personalities Menu Description (LE, MRT, RTS) | 2-5 |
| 2-4 | Machine Setup Menu | 2-6 |
| 2-5 | Calibration Values | 2-7 |
| 2-6 | LSS Module Guidelines | 2-9 |
| 3-1 | LSS Fault Codes (LE, MRT and RTS) | 3-1 |
| 3-2 | Diagnostic Menu Descriptions (ES & RT) | 3-3 |
| 3-3 | Personalities (ES & RT) | 3-3 |
| 3-4 | Machine Setup | 3-4 |
| 3-5 | Calibration Values | 3-5 |
| 4-1 | LSS Fault Codes (RS ONLY) | 4-1 |
| 4-2 | Diagnostic Menu Descriptions (RS) | 4-2 |
| 4-3 | Personalities Menu Description (RS) | 4-3 |
| 4-4 | Angle Sensor Calibration Failure Troubleshooting (RS Only) | 4-5 |
| 4-5 | Load Calibration Failure Troubleshooting (RS Only) | 4-7 |
| 5-1 | LSS Troubleshooting Chart - General | 5-4 |
| 5-2 | LSS Troubleshooting Chart - Calibration | 5-5 |

| | | |
|-----|---|------|
| 5-3 | LSS Troubleshooting Chart - Measurement Performance | 5-6 |
| 5-4 | LSS Troubleshooting Chart - Host System Functionality | 5-8 |
| 5-5 | LSS Module System Interface Connector - Power & Digital (J1 - Grey) | 5-10 |
| 5-6 | LSS Module System Interface Connector – Communication (J1 - Black) | 5-10 |
| 5-7 | LSS Module Load Cell Connector Pinout (J5, J6, J7, J8) | 5-10 |
| 6-1 | Platform Calibration Weight - RS. | 6-1 |
| 6-2 | System Activation Height - RS | 6-2 |
| 6-3 | LSS Troubleshooting - RS. | 6-3 |
| 6-4 | Connections to Host Control System (J1-Black) (RS) | 6-7 |
| 6-5 | Connections to Host Control System (J2-Blue) (RS) | 6-7 |
| 6-6 | Angle Sensor Connector Pinout (RS) | 6-7 |
| 6-7 | Pressure Transducer Connector Pinout (RS) | 6-7 |

SECTION 1. ANALYZER OPERATION - ALL

NOTE: This manual is intended as a supplement to the individual machine's Operators and Safety Manual.

1.1 INTRODUCTION & OPERATION

NOTE: It is the responsibility of the owner/user/operator/lessor/lessee to read & understand this manual and the machine Operators & Safety Manual and to prevent overloading the platform. Do not operate a machine with a disconnected or inoperative Load Sensing System.

The JLG-designed Load Sensing System (LSS) measures platform load. If the actual platform load exceeds the selected Rated Load, the following will occur:

1. The Overload Visual Warning Indicator will flash at the selected control position (platform or ground).
2. The Platform and Ground Alarms will sound 5 seconds On, and 2 seconds Off.
3. All normal movement will be prevented from the platform control position (optional - ground control functions may be prevented).
4. Further movement is permitted by:
 - a. Removing the excess platform load until actual platform load is less than Rated Load.
 - b. By an authorized person at the ground control position (optional - ground control functions may be prevented).

NOTICE

THE LOAD SENSING SYSTEM MUST BE CALIBRATED WHEN ONE OR MORE OF THE FOLLOWING CONDITIONS OCCUR:

- a. LSS System initial installation
- b. LSS Module replacement
- c. LSS Sensor removal or replacement
- d. Addition or removal of certain platform mounted accessories. (Refer to Calibration in Section 2)
- e. Platform is removed, replaced, repaired or shows evidence of impact.

NOTICE

THE LOAD SENSING SYSTEM REQUIRES PERIODIC FUNCTION VERIFICATION NOT TO EXCEED 6 MONTHS FROM PREVIOUS VERIFICATION. REFER TO TESTING & EVALUATION IN SECTION 2.

Calibration of the Load Sensing System is performed by connecting the JLG Analyzer (Analyzer Kit, JLG part no. 2901443). All calibration procedures are menu driven through the use of the Analyzer.

1.2 USING THE ANALYZER

With the machine power on and the analyzer connected properly, the analyzer will display the following:

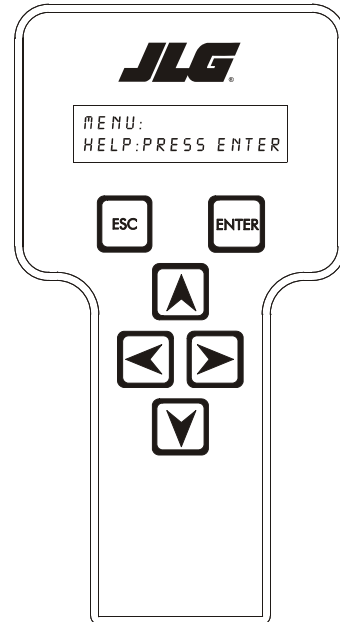

**HELP:
PRESS ENTER**

At this point, using the **RIGHT** and **LEFT** arrow keys, you can move between the top level menu items. To select a displayed menu item, press **ENTER**. To cancel a selected menu item, press **ESC**.; then you will be able to scroll using the right and left arrow keys to select a different menu item.

If you press **ENTER** at the **HELP: PRESS ENTER** display and there are no faults, the Analyzer will display **EVERYTHING OK**. In the event of a fault, the Analyzer will display a **Help Message**.

If **ENTER** is pressed again, the Analyzer will display **LOGGED HELP**, a record of the last 16 faults. Use the left and right arrow keys to scroll through the fault log. To return to the top level menu, press the **ESC** key twice.

When a top level menu entry is selected, a new set of menu items will be displayed.

Pressing **ENTER** while viewing any of the above menu entries will display additional sub-menus. Typically, the sub-menu is where parameter information is displayed or changed. You may only view Personality settings while in Access Level 2. Access Level 1 is required to change Personality settings and calibrate.

SECTION 1 - ANALYZER OPERATION - ALL

The **ESC** key may be used to leave a sub-menu at any time.

1.3 CHANGING THE ACCESS LEVEL OF THE HAND HELD ANALYZER

When the analyzer is first connected, you will be in access level 2 which enables you to only view most settings which cannot be changed until you enter a password to advance to a lower level. This ensures that a setting cannot be accidentally altered. To change the access level, the correct password must be entered. To enter the password, scroll to the **ACCESS LEVEL** menu. For example:

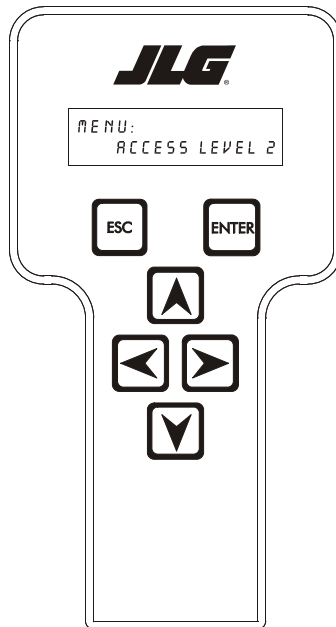

**MENU:
ACCESS LEVEL 2**

Press **ENTER** to select the **ACCESS LEVEL** menu.

Using the **UP** or **DOWN** arrow keys, enter the first digit of the password, 3.

Then using the **RIGHT** arrow key, position the cursor to the right one space to enter the second digit of the password.

Use the **UP** or **DOWN** arrow key to enter the second digit of the password which is 33271.

Continue using the arrow keys until all the remaining digits of the password is shown.

Once the correct password is displayed, press **ENTER**. The access level should display the following, if the password was entered correctly:

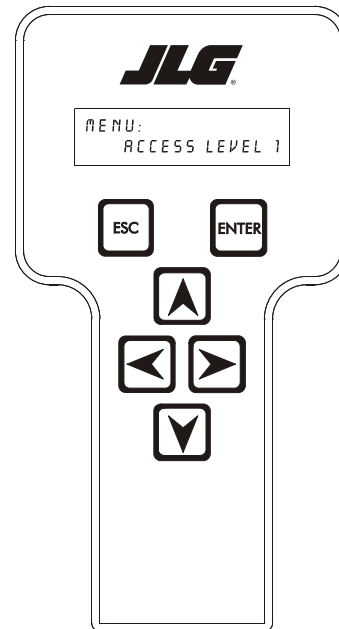

**MENU:
ACCESS LEVEL 1**

Repeat the above steps if the correct access level is not displayed or you can not adjust the personality settings.

1.4 VIEWING & ADJUSTING PARAMETERS USING THE HAND HELD ANALYZER

Once you have gained access to level 1, and a personality item is selected, press the UP or DOWN arrow keys to adjust its value, for example:

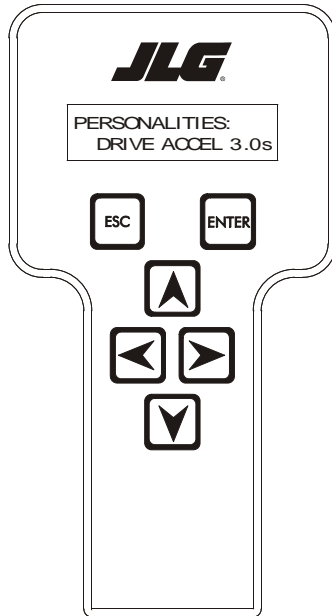

**PERSONALITIES:
OVR DEBNCE 3.0s**

There will be a minimum and maximum for the value to ensure efficient operation. The Value will not increase if the **UP** arrow is pressed when at the maximum value nor will the value decrease if the **DOWN** arrow is pressed and the value is at the minimum value for any particular personality. If the value does not change when pressing the up and down arrows, check the access level to ensure you are at Access Level 1.

SECTION 2. OPERATION - (LE, MRT, RTS)

2.1 CONNECTING THE JLG CONTROL SYSTEM ANALYZER (LE, MRT & RTS)

NOTICE

THE LOAD SENSING SYSTEM MODULE HAS AN INDEPENDENT ANALYZER CONNECTION LOCATED NEAR THE MODULE. DO NOT CONFUSE IT WITH THE ANALYZER CONNECTION FROM THE HOST CONTROL SYSTEM.

1. Connect the cable supplied with the Analyzer to the LSS Module located beneath the platform and connect the remaining end of the cable to the analyzer.

NOTE: *The cable has a four-pin connector at each end of the cable; The cable cannot be connected backwards.*

2. Power-up the Control System by turning the key to the Platform or Ground position and pulling both emergency stop buttons.

2.2 HELP MENU & FAULT CODES (LE, MRT & RTS)

The Help Menu is a troubleshooting tool to communicate detected System Faults to the technician. The following table documents the Faults for the Load Sensing System. To access the Help Menu, use the LEFT and RIGHT arrow keys to select HELP: PRESS ENTER from the Top Level Menu. Press the ENTER key to view the menu.

When accessing the Help Menu, the JLG Analyzer will display EVERYTHING OK if the platform is not overloaded and no difficulties are detected. Otherwise, the JLG Analyzer will display OVERLOADED.

In the event of difficulty, the user can press ENTER again to display Logged Help, which is a record of the last 16 Fault Messages. The following table lists each Help/Logged Message, the Flash Code (for each Fault, the module will flash the two-digit code on its LED) triggered by the Fault, and a Description of the Situation (cause).

Table 2-1. LSS Fault Codes (LE, MRT and RTS)

| Help/Logged Message | Flash Code | Description of Situation |
|---------------------|------------|---|
| Everything OK | LED ON | The "Normal" Help Message |
| <MIN CAL | | Calibration attempt Unsuccessful, Empty Platform appears to weigh too little. Improper Model Selection (Machine Setup) may cause the LSS Module to expect the wrong Empty Platform Weight. This also may be caused by a damaged sensor or associated wiring. Finally, this condition may occur if mechanical interference between the platform and support structure exists (all weight must transfer through sensors). |
| >MAX CAL | | Calibration attempt Unsuccessful, Empty Platform appears to weigh too much. This situation has the same root causes as the "< MIN CAL" Fault Message. |
| BATT TOO LOW | 4/1 | Incoming Supply Voltage <9.0 Vdc. The control system's battery voltage is too low due to excessive electrical load or discharge. |
| BATT TOO HIGH | 4/4 | Incoming Supply Voltage >34.0 Vdc. The control system's battery voltage is too high. This may be due to over-charging or improper charger operation. |
| CELL #1 ERROR | 8/1 | Cell #1's Bridge <2V, >3V, or could not read Cell #1's Internal Memory. This situation indicates damage to the sensor or its wiring. |
| CELL #2 ERROR | 8/2 | Cell #2's Bridge <2V, >3V, or could not read Cell #2's Internal Memory. This situation indicates damage to the sensor or its wiring. |
| CELL #3 ERROR | 8/3 | Cell #3's Bridge <2V, >3V, or could not read Cell #3's Internal Memory. This situation indicates damage to the sensor or its wiring. |
| CELL #4 ERROR | 8/4 | Cell #4's Bridge <2V, >3V, or could not read Cell #4's Internal Memory. This situation indicates damage to the sensor or its wiring. |
| WATCHDOG RST | 9/1 | Microprocessor's Watchdog Timer Triggered. This is an indication that the LSS Module has been exposed to excessive electrical noise, or has experienced a hardware difficulty. |
| EEPROM ERROR | 9/2 | Memory used to retain Personality/Machine Setup/Calibration has been corrupted and must be reset by verifying all entries and re-calibrating. |
| NO CAL | 9/3 | Calibration has not been successfully completed. A new LSS Module will display this message until properly calibrated. |

SECTION 2 - OPERATION - (LE, MRT, RTS)

Table 2-1. LSS Fault Codes (LE, MRT and RTS)

| Help/Logged Message | Flash Code | Description of Situation |
|---------------------|------------|---|
| INTERNAL ERR | 9/9 | Pin excitation <4.25 V. The sensors may be excessively loading the excitation supply, or the LSS Module may have hardware difficulty. |
| | | High Side Driver Error. The load attached to OUT1 or OUT2 is shorted to battery or ground and has been detected by the LSS module. |
| | | DRDY Interrupt from A/D missing. This may indicate an LSS Module hardware difficulty. |

2.3 DIAGNOSTIC MENU (LE, MRT & RTS)

The Diagnostic Load Menu is another troubleshooting tool for the Load Sensing System. Sensor and status information is presented in real-time for the technician. Several sub-menus exist to organize the data.

Note that the Diagnostic Menu changes based on MODEL Parameter in the Machine Setup Menu (some displays are suppressed). The information presented in the following table will be proper when MODEL=3369LE/4069LE/500RTS or 260MRT (refer to Machine Setup Menu).

To access the Diagnostic Menu, use the LEFT and RIGHT Arrow keys to select DIAGNOSTICS from the Top Level Menu. Press the ENTER key to view the menu.

Press the LEFT and RIGHT Arrow keys to view the displays and select the various sub-menus (PIN 1, PIN 2, etc.). To access a sub-menu, press the ENTER key. Once in a sub-menu, press the LEFT and RIGHT Arrow keys to view the various displays (just like a Top Level menu). To exit a sub-menu, press the ESC key.

The table below details the structure of the Diagnostic Menu, and describes the meaning of each piece of information presented.

Table 2-2. Diagnostic Menu Descriptions (LE, MRT & RTS)

| Diagnosics Menu (Displayed on Analyzer 1 st Line) | Parameter (Displayed on Analyzer 2 nd Line) | Parameter Value (Displayed on Analyzer 2 nd Line) | Description |
|---|---|--|--|
| | PLTLOAD | ±XXXX LBS or Kg | Displays (Total Measured Force – Empty Platform Calibration) |
| | PLTGROS | ±XXXX LBS or Kg | Displays Total Measured Force (Sum of Pins 1 thru 4 LOAD) |
| | OVERLOADED? | Yes / No | Displays Current LSS Module Overload Status |
| CELL 1: | | | |
| | LOAD | ±XXXX LBS or Kg | Displays Calibrated Cell Reading in Current Units |
| | RDG | ±XX.XXXX mV/V | Displays Pin Reading in mV/V |
| | INPUT | ±XX.XXXX mV | Displays Pin Reading in mV |
| | GAIN | XXXX.X | Displays calibration factor from pin |
| CELL 2: | | | |
| | LOAD | ±XXXX LBS or Kg | Displays Calibrated Cell Reading in Current Units |
| | RDG | ±XX.XXXX mV/V | Displays Pin Reading in mV/V |
| | INPUT | ±XX.XXXX mV | Displays Pin Reading in mV |
| | GAIN | XXXX.X | Displays calibration factor from pin |
| CELL 3: | | | |
| | LOAD | ±XXXX LBS or Kg | Displays Calibrated Cell Reading in Current Units |
| | RDG | ±XX.XXXX mV/V | Displays Pin Reading in mV/V |
| | INPUT | ±XX.XXXX mV | Displays Pin Reading in mV |
| | GAIN | XXXX.X | Displays calibration factor from pin |
| CELL 4: | | | |
| | LOAD | ±XXXX LBS or Kg | Displays Calibrated Cell Reading in Current Units |
| | RDG | ±XX.XXXX mV/V | Displays Pin Reading in mV/V |
| | INPUT | ±XX.XXXX mV | Displays Pin Reading in mV |
| | GAIN | XXXX.X | Displays calibration factor from pin |
| SYSTEM: | | | |
| | OVLOAD STAT | OFF / ON | State of Overload Status Digital Output |
| | WARNING | OFF / ON | State of Warning Digital Output |
| | MOT INHIBIT | NO / YES | Status of Internal Motion Inhibit Flag |
| | MOTION #1 | OFF / ON | Status of Digital Input #1 |

SECTION 2 - OPERATION - (LE, MRT, RTS)

Table 2-2. Diagnostic Menu Descriptions (LE, MRT & RTS)

| Diagnosics Menu (Displayed on Analyzer 1 st Line) | Parameter (Displayed on Analyzer 2 nd Line) | Parameter Value (Displayed on Analyzer 2 nd Line) | Description |
|---|---|--|--|
| | MOTION #2 | OFF / ON | Status of Digital Input #2 |
| | MOTION #3* | OFF / ON | Status of Digital Input #3 |
| | BATTERY | XX.XXV | Displays Current Battery Voltage |
| | EXCITE | X.XXXXV | Displays Load Pin Excitation Voltage |
| | TEMP | +/-XXX.X Deg C | Display the Temperature Sensed by the LSS Module for Scissor Pin Compensation |
| VERSIONS: | | | |
| | SOFTWARE | PX.XX | Displays LSS Module Software Version |
| | HARDWARE | X | Display LSS Module Hardware Revision |
| | ANALYZER | VX.XXXX | Displays Analyzer Software Version |

2.4 PERSONALITIES (LE, MRT & RTS)

NOTICE

NOTE: The following parameter adjust performance of the Load Sensing System. All adjustments must be made at access level 1 (33271).

THE SETTINGS UNDER THE FACTORY MENU OPTION ARE UNIQUE TO EACH MODULE. THESE SETTINGS ARE NOT TO BE ALTERED. IN THE EVENT THAT THESE SETTINGS ARE ALTERED, CONTACT JLG WITH THE SERIAL NUMBER OF THE MODULE.

Table 2-3. Personalities Menu Description (LE, MRT, RTS)

| Personalities (Displayed on Analyzer 1st line) | Parameter (Displayed On Analyzer 2nd line) | Description | 4069LE | 3369LE | 500RTS | 260MRT |
|--|--|--|-------------------|--------------------|--|--------------------|
| | OVERLD XXXX LBS (KGS) | Displays/adjusts the overload limit for this AWP | 550 LBS (378 KGS) | 1042 LBS (473 KGS) | No Extensions- 2628 LBS (1192 KGS) Single or Dual Extensions 2083 LBS (945 KGS) MegaDeck- 1574 LBS (714 KGS) | 1320 LBS (599 KGS) |
| | ACC'Y XXXX LBS (KGS) | Displays/adjusts a de-rating for Accessories | 0 LBS (0KGS) | 0 LBS (0KGS) | 0 LBS (0KGS) | 0 LBS (0KGS) |
| | MTN DELAY XS | Displays/adjusts the delay between motion ceasing and evaluation of overload | 2 SEC | 2 SEC | 2 SEC | 2 SEC |
| | OVR DBNCE XS | Displays/adjusts the de-bounce delay before an overload | 3 SEC | 3 SEC | 3 SEC | 3 SEC |
| | OVR HOLD XS | Displays/adjusts the minimum delay before an overload can be released. | 5 SEC | 5 SEC | 5 SEC | 5 SEC |
| FACTORY | #1 GAIN X.XXXX | Displays/calibrates the LSS Module analog channel gain | | | X | |
| | #1 ZERO + X.XXXX mV | Displays/calibrates the LSS Module analog channel offset. | | | X | |
| | #2 GAIN X.XXXX | Displays/calibrates the LSS Module analog channel gain | | | X | |
| | #2 ZERO + X.XXXX mV | Displays/calibrates the LSS Module analog channel offset | | | X | |
| | #3 GAIN X.XXXX | Displays/calibrates the LSS Module analog channel gain | | | X | |
| | #3 ZERO + X.XXXX mV | Displays/calibrates the LSS Module analog channel offset | | | X | |
| | #4 GAIN X.XXXX | Displays/calibrates the LSS Module analog channel gain | | | X | |
| | #4 ZERO + X.XXXX mV | Displays/calibrates the LSS Module analog channel offset | | | X | |
| | EX GAIN X.XXXX | Displays/calibrates the LSS Module excitation measurement gain | | | X | |
| | TEMP OFFS +/- XXX.X | Displays/calibrates the LSS Module internal temp sensor | | | X | |

2.5 MACHINE SETUP MENU (LE, MRT & RTS)

The Machine Setup Menu is used to configure the Load Sensing System for application on a particular JLG model, and select the desired force units (i.e. pounds or kilograms). In addition, the technician can trigger the LSS Module to restore Defaults to all Personalities Parameters by changing the MODEL to any other selection, and then re-selecting proper model.

Note that Diagnostics and Personalities Menus change based on MODEL Parameter (some displays are suppressed).

To access the Machine Setup Menu, use the LEFT and RIGHT Arrow keys to select MACHINE SETUP from the Top Level Menu. Press the ENTER key to view the menu. Press the LEFT and RIGHT Arrow keys to view the displays.

The following table details the structure of the Machine Setup Menu, and describes the meaning of each parameter.

Table 2-4. Machine Setup Menu

| Parameter (Displayed on Analyzer 2 nd Line) | Parameter Value (Displayed on Analyzer 2 nd Line) | Description |
|--|--|--|
| MODEL: | =BOOM LIFT =4069LE =3369LE =500RTS =260MRT =Scissor | Displays/adjusts Model Selection. Must be set to proper model for this application. (Scissor available after software V7.00) |
| UNITS: | =LBS =Kg | Displays/adjusts global force units |

2.6 CALIBRATION MENU (LE, MRT & RTS)

The Calibration Menu is used to zero the Empty Platform weight.

To access the Calibration Menu, use the LEFT and RIGHT Arrow keys to select CALIBRATION from the Top Level Menu. Press the ENTER key to view the menu.

NOTE: The Calibration Menu is not available in Access Level 2.

Upon entry to the Calibration Menu, the LSS Module shall communicate to the Analyzer:

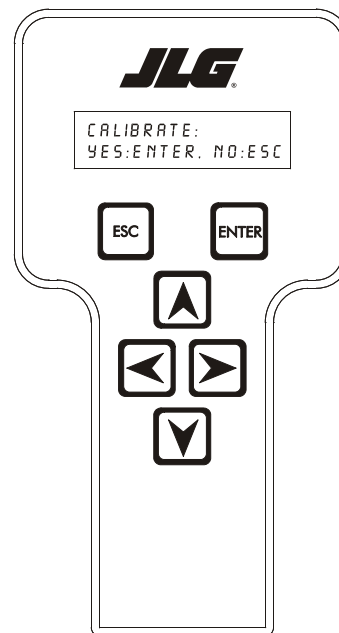

CALIBRATE:
YES:ENTER, NO:ESC

Pressing the ESC key will return the user to the top level menu and not disturb the prior calibration information.

Pressing the ENTER key will confirm that the platform is empty (except for factory-installed options outside the Rated Load). The LSS Module will calculate the total of all load cell readings and ensure that the total is greater than minimum calibration value, but less than maximum calibration value. If successful, the Analyzer will show the following:

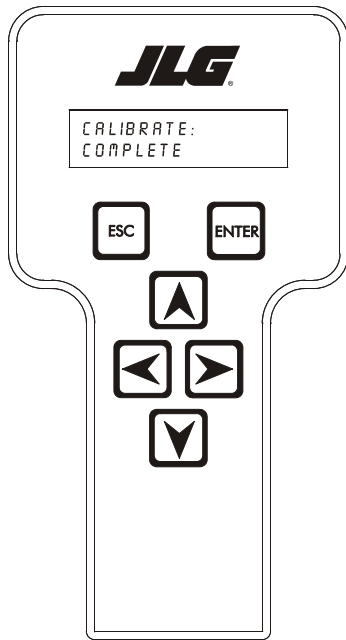

CALIBRATE:
COMPLETE

Table 2-5. Calibration Values

| MODELS | 4069LE | 3969LE | 500RTS | 260MRT |
|---------------------------|---------------------|---------------------|----------------------|---------------------|
| Minimum Calibration Value | 850 lb (385 kg) | 850 lb (385 kg) | 1100 lb (499 kg) | 750 lb (340 kg) |
| Maximum Calibration Value | 1425 lb (646 kg) | 1425 lb (646 kg) | 2950 lb (1338 kg) | 1250 lb (567 kg) |

If the empty platform weight is less than minimum calibration value, the calibration attempt will be unsuccessful and the Analyzer will show the following:

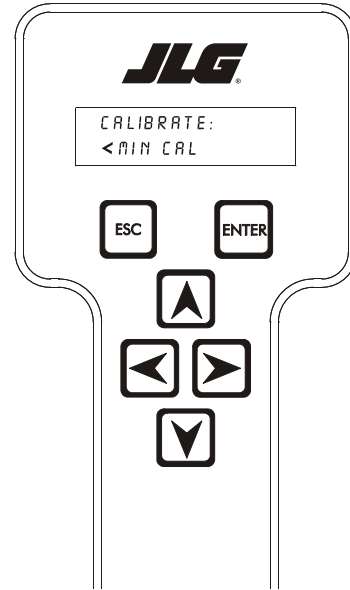

CALIBRATE:
< MIN CAL

If the empty platform weight is greater than maximum calibration value, the calibration attempt will be unsuccessful and the Analyzer will show the following:

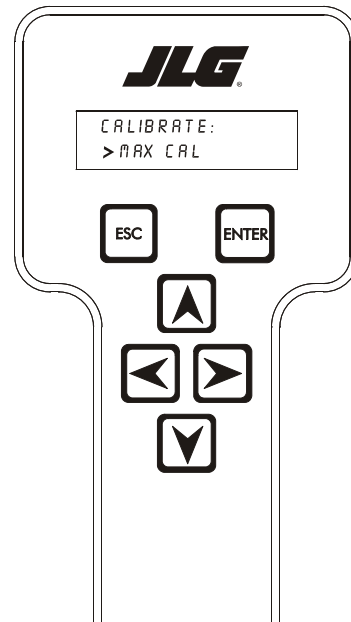

CALIBRATE:
> MAX CAL

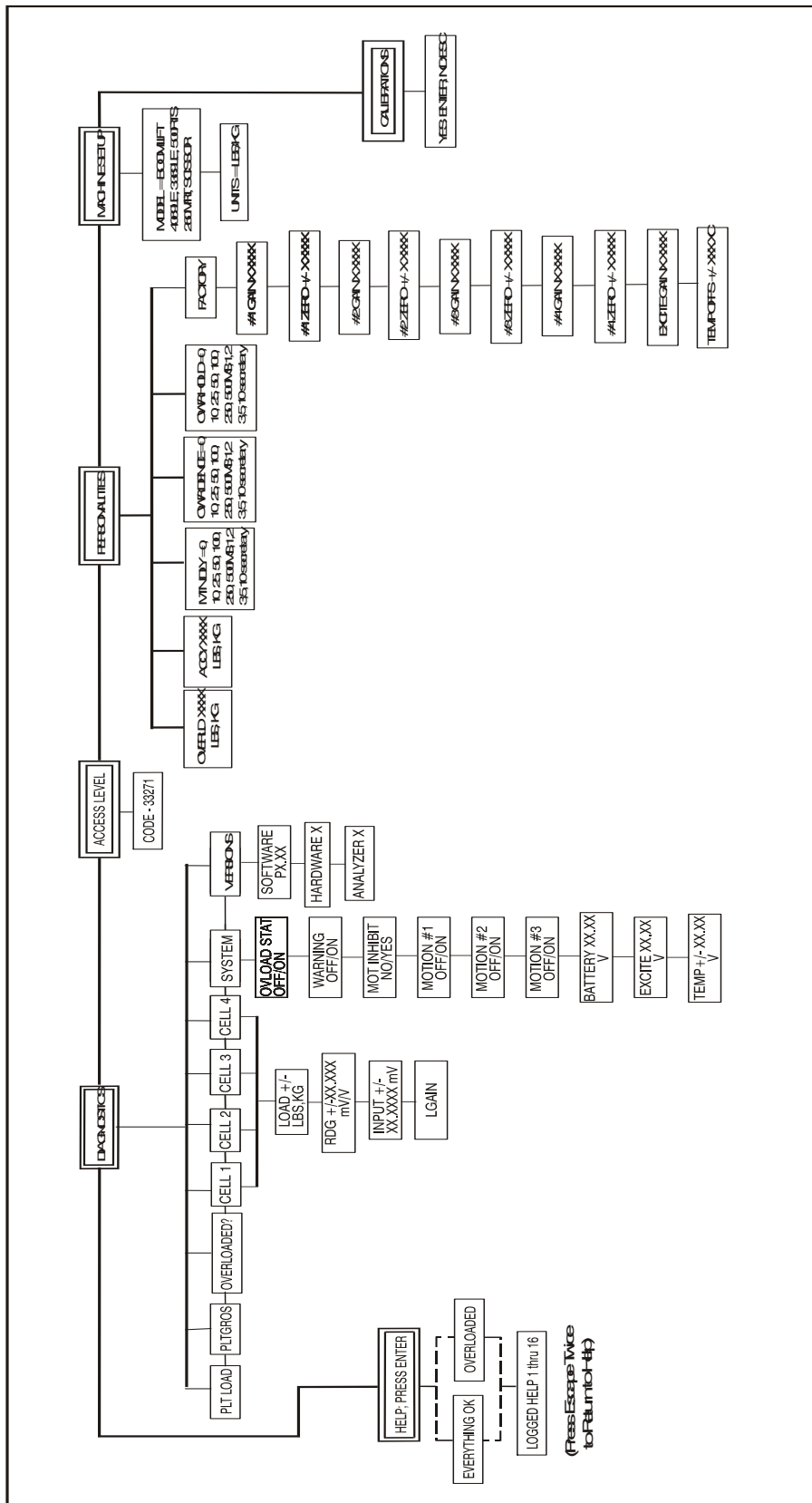

Figure 2-1. Module Analyzer Flow Chart

**2.7 JLG WORKSTATION IN THE SKY™
ACCESSORIES**

The Load Sensing System must be configured for proper operation with JLG Sky™ Accessories. Calibration of the Load Sensing System can be performed with the Accessory mounted in the platform.

A platform-mounted accessory slightly reduces the amount of load that can be carried before the vehicle becomes overloaded. This extra load must be accounted for to enable the accessory to be mounted during Calibration.

A De-Rating is provided for JLG Sky Accessories via decal and/or the JLG Workstation in the Sky™ Accessory Manual. This De-Rating must be entered into the LSS Module's ACC'Y Personality to cause the system to accurately indicate overload (by the De-Rating factor).

Example: Consider that of the Easi-Cladder™ with a De-Rating of 300 lbs (136 kg) mounted on a 500RTS. Without De-Rating, the Load Sensing System will declare on Overload at 2750 lb (1247 kg), which is 110% of its 2500 lb (1134 kg) rated Load. When the De-Rating for Easi-Cladder™ is entered into the ACC'Y Personality, the LSS will declare Overload 300 lb (136 kg) earlier (2450 lb or 1111 kg).

Table 2-6. LSS Module Guidelines

| PERSONALITY | SETTING |
|--------------------|-----------------|
| ACC'Y | 300 lb (136 kg) |

Procedurally, the Accessory should be mounted to the platform and the LSS Module's ACC'Y Personality should be set using the guidelines above. Calibration should be performed as outlined in this manual. During Testing & Evaluation, it should be noted that the LSS will declare Overload with less platform load (by the amount of the De-Rating).

SECTION 3. OPERATION - (ES, RT)

3.1 CONNECTING THE JLG CONTROL SYSTEM ANALYZER (ES & RT)

1. Connect the cable supplied with the Analyzer to the host control system located at the ground control station on both the ES and the RT models. There is also an alternate connection on the under side of the platform control station on the RT. Connect the remaining end of the cable to the analyzer.

NOTE: *The cable has a four-pin connector at each end of the cable; The cable cannot be connected backwards.*

2. Power-up the Control System by turning the key to the Platform or Ground position and pulling both emergency stop buttons.

3.2 HELP MENU & FAULT CODES (ES & RT)

The Help Menu is a troubleshooting tool to communicate detected System Faults to the technician. The following table documents the Faults for the Load Sensing System. To access the Help Menu, use the LEFT and RIGHT arrow keys to select HELP: PRESS ENTER from the Top Level Menu. Press the ENTER key to view the menu.

When accessing the Help Menu, the JLG Analyzer will display EVERYTHING OK if the platform is not overloaded and no difficulties are detected. Otherwise, the JLG Analyzer will display OVERLOADED.

In the event of difficulty, the user can press ENTER again to display Logged Help, which is a record of the last 16 Fault Messages. The following table lists each Help/Logged Message, the Flash Code (for each Fault, the module will flash the two-digit code on its LED) triggered by the Fault, and a Description of the Situation (cause).

Table 3-1. LSS Fault Codes (LE, MRT and RTS)

| Help/Logged Message | Flash Code | Description of Situation |
|--|------------|--|
| PLATFORM OVER-LOADED | 2-5 | The platform load measured at the Load Sensing System is excessive. Functions from the platform control are prevented, and functions from the ground control may be prevented, depending on machine. |
| BATTERY TOO HIGH | 4-4 | Incoming Supply Voltage >34.0 Vdc. The control system's battery voltage is too high. This may be due to over-charging or improper charger operation. |
| BATT TOO LOW | 4-4 | Incoming Supply Voltage <9.0 Vdc. The control system's battery voltage is too low due to excessive electrical load or discharge. This may compromise ability to predict weight. Recharge batteries or check for damaged batteries. |
| CANBUS FAILURE: LSS MODULE | 6-6 | The control system failed to receive messages from the LSS Module. Check wiring at the LSS Module and along scissor arms leading up to platform. |
| CELL #1 ERROR | 8-1 | Cell #1's Bridge <2V, >3V, or could not read Cell #1's Internal Memory. This situation indicates damage to the sensor or its wiring. |
| CELL #2 ERROR | 8-2 | Cell #2's Bridge <2V, >3V, or could not read Cell #2's Internal Memory. This situation indicates damage to the sensor or its wiring. |
| CELL #3 ERROR | 8-3 | Cell #3's Bridge <2V, >3V, or could not read Cell #3's Internal Memory. This situation indicates damage to the sensor or its wiring. |
| CELL #4 ERROR | 8-4 | Cell #4's Bridge <2V, >3V, or could not read Cell #4's Internal Memory. This situation indicates damage to the sensor or its wiring. |
| WATCHDOG RST | 9-1 | Microprocessor's Watchdog Timer Triggered. This is an indication that the LSS Module has been exposed to excessive electrical noise, or has experienced a hardware difficulty. |
| EEPROM ERROR | 9-2 | Memory used to retain Personality/Machine Setup/Calibration has been corrupted and must be reset by verifying all entries and re-calibrating. After resolution, re-cycle power to clear difficulty. |
| LSS NOT CALIBRATED | 9-3 | Calibration has not been successfully completed. A new LSS Module will display this message until properly calibrated. |
| LSS INTERNAL ERROR - PIN EXCITATION | 9-9 | Pin excitation <4.25 V. The sensors may be excessively loading the excitation supply, or the LSS Module may have hardware difficulty. |
| LSS INTERNAL ERROR - DRDY MISSING FROM A/D | 9-9 | DRDY Interrupt from LSS Module's A/D converter missing. This may indicate an LSS Module hardware difficulty. |

3.3 DIAGNOSTIC MENU (ES & RT)

The Diagnostic Load Menu is another troubleshooting tool for the Load Sensing System. Sensor and status information is presented in real-time for the technician.

To access the Diagnostic Menu, use the LEFT and RIGHT Arrow keys to select DIAGNOSTICS from the Top Level Menu. Press the ENTER key to select the menu.

NOTE: The Diagnostic, Load menu is not available when the LSS is not enabled. (Machine Setup, Load is set to 0=Not Installed)

Press the LEFT and RIGHT Arrow keys to view the load sub-menus and press the enter key. Once in the load sub-menu, press the LEFT and RIGHT arrow keys to view the various displays.

The table below details the structure of the Diagnostic, Load Menu, and describes the meaning of each piece of information presented.

Table 3-2. Diagnostic Menu Descriptions (ES & RT)

| Diagnosics Menu (Displayed on Analyzer 1 st Line) | Parameter (Displayed on Analyzer 2 nd Line) | Parameter Value (Displayed on Analyzer 2 nd Line) | Description |
|---|--|---|--|
| LOAD: | | | |
| | PLTLOAD | ±XXXX Kg | Displays (Total Measured Force – Empty Platform Calibration), in kilograms |
| | PLTGROS | ±XXXX Kg | Displays Total Measured Force (Sum of Pins 1 thru 4 LOAD) in kilograms |
| | OVERLOADED? | Yes / No | Displays Current LSS Module Overload Status |
| | CELL 1 | ±XXXX Kg | Displays Calibrated Cell Reading in kilograms |
| | CELL 2 | ±XXXX Kg | Displays Calibrated Cell Reading in kilograms |
| | CELL 3 | ±XXXX Kg | Displays Calibrated Cell Reading in kilograms |
| | CELL 4 | ±XXXX Kg | Displays Calibrated Cell Reading in kilograms |
| | ANALYZER | VX.XXXX | Displays Analyzer Software Version |

3.4 PERSONALITIES (ES & RT)

The following parameter in the PERSONALITIES, LOAD menu adjust performance of the LSS. All adjustments must be made in Access Level 1 (33271).

NOTICE

REFER TO JLG WORKSTATION IN THE SKY™ ACCESSORIES IN THIS SECTION WITH REGARD TO SETTING THE ACCY PERSONALITIES.

Table 3-3. Personalities (ES & RT)

| Submenu (Displayed on analyzer1st Line) | Parameter (Displayed on analyzer 2nd line) | Description |
|---|--|--|
| LOAD: | ACC ^Y XXXX KG | Displays/adjusts a derating for accessories |
| | OVR DBNCE 3 S | Displays/ adjusts the debounce delay before an overload |
| | OVR HOLD 5 S | Displays/adjusts the minimum delay before an overload can be released. |

3.5 MACHINE SETUP MENU (ES & RT)

The LOAD submenu within the machine setup menu is used to configure the LSS. To access the Machine Setup, Load menu, use the Left and Right arrow keys to select MACHINE SETUP from the Top Level Menu. Press the ENTER key to select the menu. Press the Left and Right arrow keys to select LOAD from the MACHINE SETUP menu. Press the Enter key to view the submenu.

The following table details the structure of the load submenu and describes the meaning of the parameter.

Table 3-4. Machine Setup

| Submenu (Displayed on analyzer 1st Line) | Parameter (Displayed on analyzer 2nd line) | Description |
|--|--|------------------------------------|
| LOAD: | 0 = NOT INSTALLED | Displays/adjusts the LSS Module |
| | 1 = CUTOUT PLT | |
| | 2 = CUTOUT ALL | |

3.6 CALIBRATION MENU (ES & RT)

The Load submenu within the Calibration Menu is used to zero the Empty Platform weight.

To access the Calibration Load Menu, use the LEFT and RIGHT Arrow keys to select CALIBRATION from the Top Level Menu. Press the ENTER key to select the menu. Press the LEFT and RIGHT arrow keys to select LOAD from the CALIBRATION menu. Press the ENTER key to view the submenu.

NOTE: The Calibration Menu is not available in Access Level 2.

Upon entry to the Calibration, Load Menu, the analyzer will display:

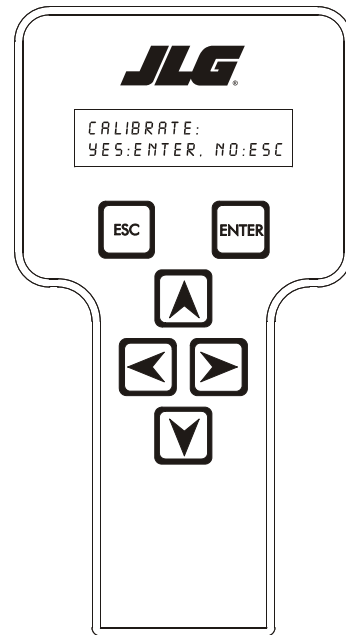

CALIBRATE:
YES:ENTER, NO:ESC

Pressing the ESC key will return the user to the top level menu and not disturb the prior calibration information.

SECTION 3 - OPERATION - (ES, RT)

Pressing the ENTER key will confirm that the platform is empty (except for factory-installed options outside the Rated Load). The LSS Module will calculate the total of all load cell readings and ensure that the total is greater than minimum calibration value, but less than maximum calibration value. If successful, the Analyzer will show the following:

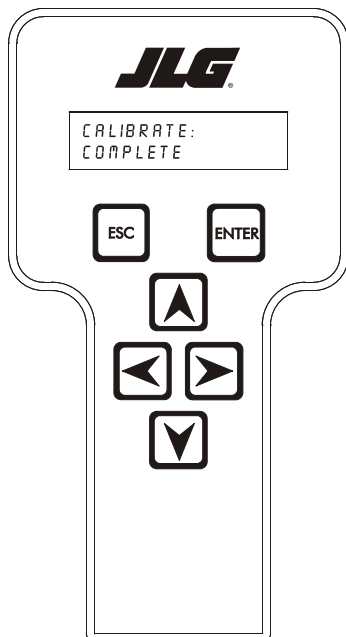

CALIBRATE:
COMPLETE

Table 3-5. Calibration Values

| MODELS | ES | RT |
|---------------------------|--------------------|---------------------|
| Minimum Calibration Value | 45 KG (99 LB) | 225 KG (496 LB) |
| Maximum Calibration Value | 275 KG (606 LB) | 1020KG (2249 LB) |

If the empty platform weight is less than minimum calibration value, the calibration attempt will be unsuccessful and the Analyzer will show the following:

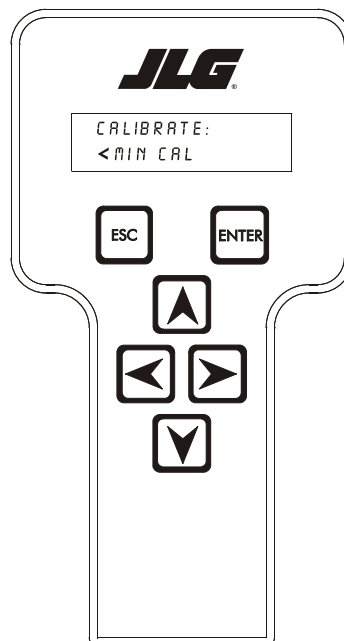

CALIBRATE:
< MIN CAL

If the empty platform weight is greater than maximum calibration value, the calibration attempt will be unsuccessful and the Analyzer will show the following:

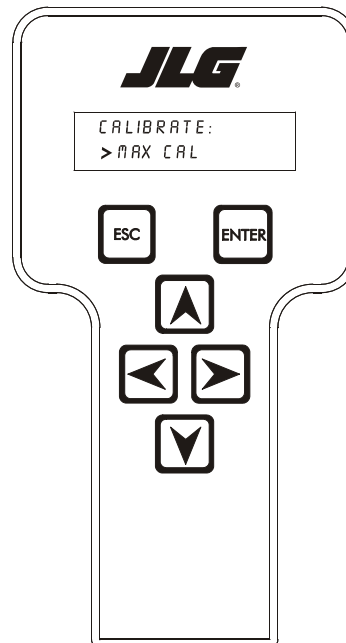

CALIBRATE:
> MAX CAL

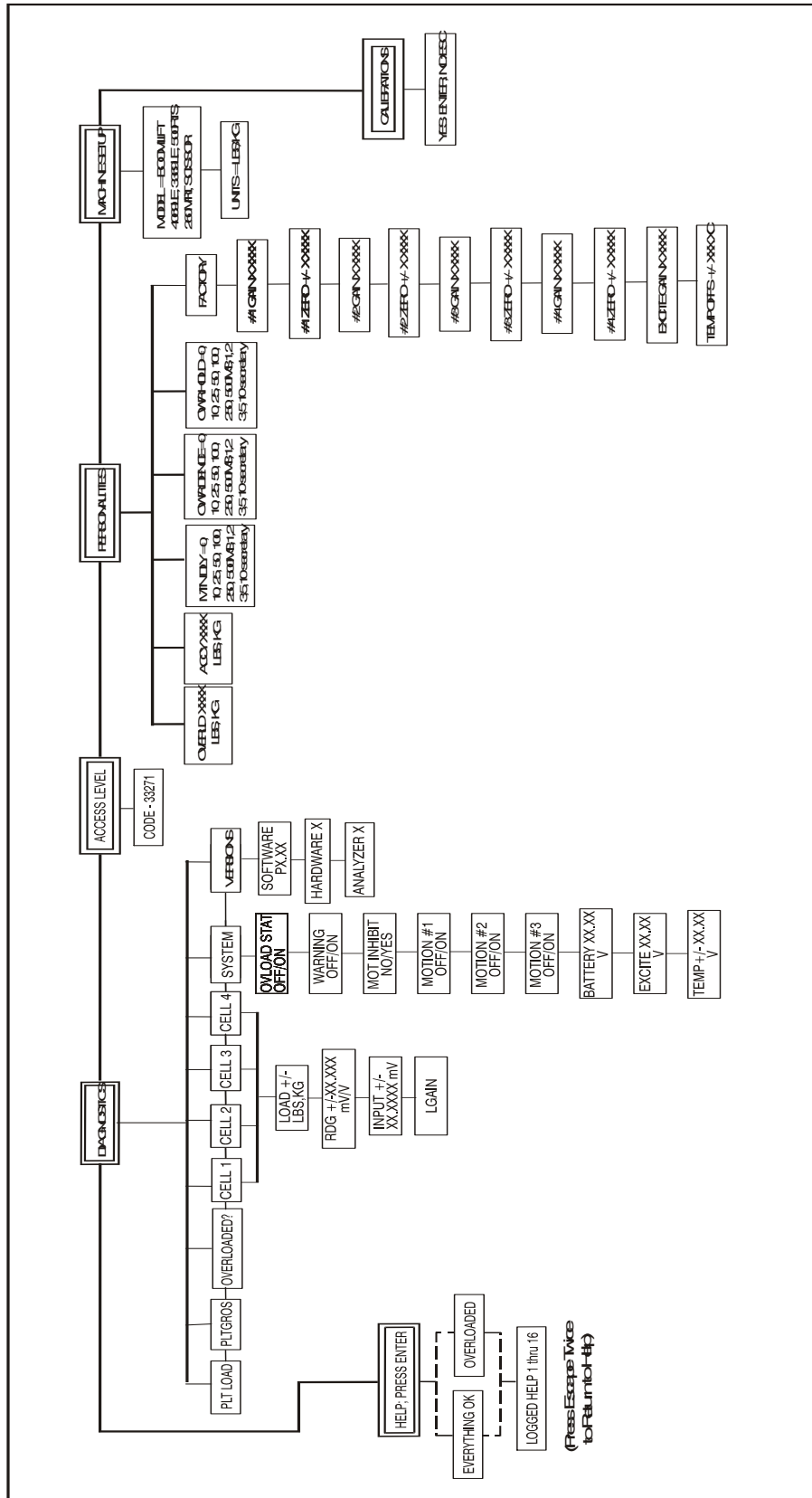

Figure 3-1. Module Analyzer Flow Chart

SECTION 4. OPERATION - (RS)

4.1 CONNECTING THE JLG CONTROL SYSTEM ANALYZER (RS)

1. Remove the compartment panel on the ground control side of the machine.
2. Disconnect the 4 pin connector which provides power and information to the MDI Display.
3. Connect the cable supplied with the Analyzer to the mating 4 pin connector that was just disconnected.

NOTE: *The cable has a four-pin connector at each end of the cable; The cable cannot be connected backwards.*

4. Power-up the Control System by turning the key to the Ground Control position and pull the Ground emergency stop button.

4.2 HELP MENU & FAULT CODES (RS)

The Help Menu is a troubleshooting tool to communicate detected System Faults to the technician. The following table documents the Faults for the Load Sensing System. To access the Help Menu, use the LEFT and RIGHT arrow keys to select HELP: PRESS ENTER from the Top Level Menu. Press the ENTER key to view the menu.

When accessing the Help Menu, the JLG Analyzer will display EVERYTHING OK if the platform is not overloaded and no difficulties are detected. Otherwise, the JLG Analyzer will display OVERLOADED.

In the event of difficulty, the user can press ENTER again to display Logged Help, which is a record of the last 16 Fault Messages. The following table lists each Help/Logged Message, the Flash Code (for each Fault, the module will flash the two-digit code on its LED) triggered by the Fault, and a Description of the Situation (cause).

Table 4-1. LSS Fault Codes (RS ONLY)

| HELP/LOGGED MESSAGE | FLASH CODE | DESCRIPTION OF SITUATION |
|---|------------|--|
| Everything OK | LED ON | The "Normal" Help Message |
| PLATFORM OVERLOADED | 2-5 | While the Load Sensing System is enabled, the Platform Load measured by the Load Sensing System is excessive. Functions from Platform Control are prevented, and functions from Ground Control may be prevented, depending on machine configuration (Markets other than Japan). For the Japanese Market, only Lift Up is prevented and Drive (at creep speed) is allowed in the stowed position. |
| CANBUS FAILURE - LSS ANGLE SENSOR | 6-6 | The Control System Failed to receive messages from the Angle Sensor. Check wiring to the Angle Sensor. |
| LSS PRESSURE SENSOR - DISAGREEMENT | 8-2 | Pressure Sensor 1 and Pressure Sensor 2 do not agree. The system shall assume the machine is overloaded until the sensors agree. Using the Analyzer LOAD submenu under DIAGNOSTICS check PRES1 and PRES2 readings. They must agree within 75 PSI. With the safety prop engaged check to ensure that the appropriate voltage is being supplied to both sensors and that the wiring and connections are intact. The voltage between pins A and B should read +5V +/- 0.5V with the machine turned on. If the voltage supplied is correct, replace both transducers. |
| LSS ANGLE SENSOR - DIRECTION DISAGREEMENT | 8-2 | The Angle sensors change in reading does not agree with the direction of machine motion (lift up). This indicates that the direction of movement of the platform does not agree with the angle sensors change in output. Ensure that the angle sensor is installed properly and that the lever arm is not damaged. |
| LSS ANGLE SENSOR - OUT OF RANGE HIGH | 8-2 | The Angle Sensor's reading when the machine is at maximum elevation does not fall within the high end acceptable range. The Angle Sensors reading must be less than or equal to 245 counts at maximum elevation. Ensure that the Angle Sensor is mounted properly. |
| LSS ANGLE SENSOR - OUT OF RANGE LOW | 8-2 | The Angle Sensor's reading when the machine is stowed does not fall within the low end acceptable range. The Angle Sensors reading must be greater than or equal to 5 counts with the platform stowed. Ensure that the Angle Sensor is mounted properly. |
| LSS ANGLE SENSOR HAS NOT BEEN CALIBRATED | 8-2 | The Angle Sensor has never been calibrated and the control system assumes that the platform is overloaded. Calibrate the Angle Sensor using the CALIBRATION: ANGLE submenu to clear the message. |

4.3 DIAGNOSTIC MENU (RS)

The Diagnostic Load and Angle menu's are another troubleshooting tool for the Load Sensing System. Sensor and status information is presented in real-time for the technician.

To access the Diagnostic Menu, use the LEFT and RIGHT Arrow keys to select DIAGNOSTICS from the Top Level Menu. Press the ENTER key to select the menu.

NOTE: The Diagnostic Load and Angle menu's are not available when the LSS is not enabled. (Machine Setup, Load is set to 0=Not Installed)

Press the LEFT and RIGHT arrow keys to view the load and angle sub-menu and press the enter key. Once in the load and angle submenu, press the LEFT and RIGHT arrow keys to view the various displays.

The table below details the structure of the Diagnostic, Load Menu and Angle Menu, and describes the meaning of each piece of information presented.

Table 4-2. Diagnostic Menu Descriptions (RS)

| DIAGNOSTICS MENU (Displayed on Analyzer 1 st Line) | PARAMETER (Displayed on Analyzer 2 nd Line) | PARAMETER VALUE (Displayed on Analyzer 2 nd Line) | DESCRIPTION |
|--|---|---|--|
| LOAD: | OVERLOADED? | Yes/No | Displays the current LSS state. |
| | PRES1 | xxxxPSI | Displays the actual pressure reading from Pressure Transducer #1. |
| | PRES2 | xxxxPSI | Displays the actual pressure reading from Pressure Transducer #2. |
| LOAD: PRES DIF | P1-P2 | xxxxPSI | Displays the absolute pressure difference between transducer 1 and transducer 2. PRES DIF = ABSOLUTE(PRES1 - PRES2). |
| LOAD: PRES DIF | OVLDP1 | xxxxPSI | Displays the pressure difference between Lift Up or Lift Down Pressure Overload Limits (depending on motion) and Actual Pressure. MARGIN = Lift Up Pressure Overload Limit - PRES1 or MARGIN = Lift Down Pressure Overload Limit - PRES1. |
| LOAD: TOCLEAROVLDP | PRES | xxxxPSI | Displays the amount of pressure that must be reduced before the overload condition is resolved. XXX = PRES1 - (OVRPRES - PRESREDUCE). When an overload condition does not exist this value shall be 0. |
| ANGLE: | MINANGLE | xxx | Displays the angle sensors MINANGLE (stowed) value based on angle sensor calibration. |
| | MAXANGLE | xxx | Displays the angle sensors MAXANGLE (max elevation) value based on angle sensor calibration. |
| | ANGLERANGE | xxx | Displays the difference between MAXANGLE and MINANGLE. ANGLERANGE = MAXANGLE - MINANGLE. |
| | ANGLE | xxx | Displays the actual angle sensor count value at all times. |

4.4 PERSONALITIES MENU (RS)

The following parameter in the PERSONALITIES, LOAD menu adjust performance of the LSS. All adjustments must be made in Access Level 1 (33271).

Table 4-3. Personalities Menu Description (RS)

| SUBMENU (Displayed on Analyzer 1st line) | PARAMETER (Displayed on Analyzer 2nd Line) | DESCRIPTION |
|--|--|--|
| LOAD: | OVR DBNCE 0.3S | Displays/Adjusts the debounce delay for an overload. |
| | OVR HOLD 5.0S | Displays/Adjusts the minimum delay before an overload can be resolved. |

4.5 CALIBRATION MENU (RS)

NOTE: The Load Sensing System cannot be calibrated without first calibrating the machines Angle Sensor.

Angle Sensor Calibration (RS Only)

To access the Calibration Angle Menu, use the LEFT and RIGHT Arrow keys to select CALIBRATION from the Top Level Menu. Press the ENTER key to select the menu.

Press the LEFT and RIGHT arrow keys to select ANGLE from the CALIBRATION menu. Press the ENTER key to view the submenu.

Should the Analyzer read CAL ANGLE:FAIL at any time during the calibration procedure, reference the table below for the failure listed by the Analyzer.

NOTE: The Calibration Menu is not available in Access Level 2.

Upon entry to the Calibration, ANGLE Menu, the analyzer will display:

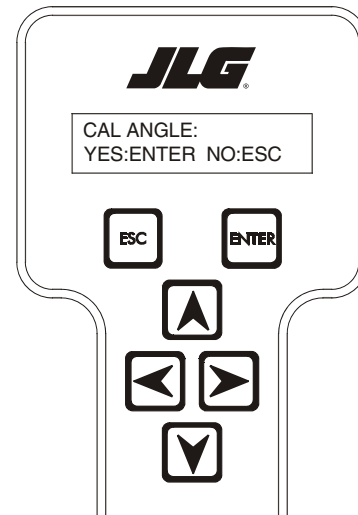

CAL ANGLE:
YES:ENTER, NO:ESC

Pressing the ESC key will return the user to the top level menu and not disturb the prior calibration information.

SECTION 4 - OPERATION - (RS)

Pressing the Enter key will request that the technician engage lift up until the platform has reached maximum height:

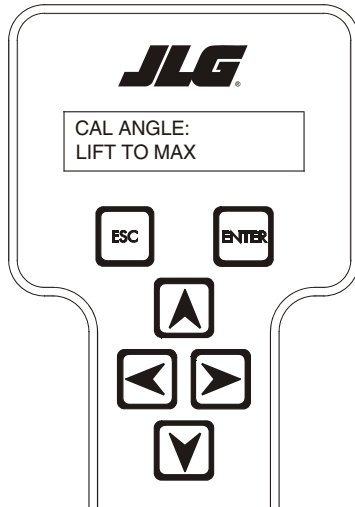

CAL ANGLE:
LIFT TO MAX

If the Angle Sensors range from stowed to maximum height is acceptable the Analyzer will display the following:

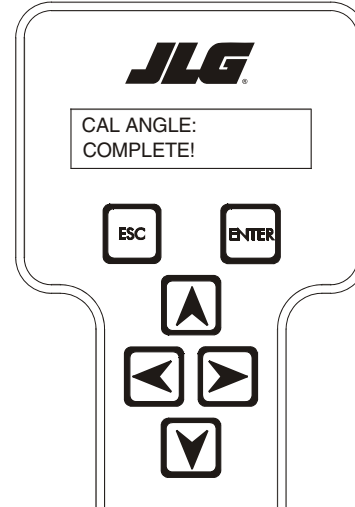

CAL ANGLE:
COMPLETE!

If the Angle Sensor's reading at maximum height is acceptable the Control System will record the sensors value and Analyzer will display the following.

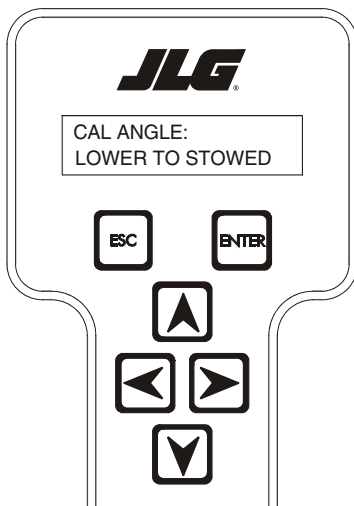

CAL ANGLE:
LOWER TO STOWED

Table 4-4. Angle Sensor Calibration Failure Troubleshooting (RS Only)

| ANGLE SENSOR CALIBRATION FAILURE (Displayed on Analyzer 2nd Line) | DESCRIPTION | CHECK |
|--|--|--|
| MAX NOT IN RANGE | The Angle Sensors upper limit is not acceptable. It must fall within +/- 35 counts of 210 counts. | <ul style="list-style-type: none"> • Check the Angle Sensor to ensure it is installed properly. • Ensure that the Angle Sensors lever arm is installed properly. |
| MAXANGLE TOO HIGH | The MAXANGLE value was greater than 245 counts. The MAXANGLE value must be a number less than or equal to 245. | <ul style="list-style-type: none"> • Check the Angle Sensor to ensure it is installed properly. • Ensure that the Angle Sensors lever arm is installed properly. |
| LOW NOT IN RANGE | The Angle Sensors lower limit is not acceptable. It must fall within +/- 35 counts of 40 counts. | <ul style="list-style-type: none"> • Check the Angle Sensor to ensure it is installed properly. • Ensure that the Angle Sensors lever arm is installed properly. |
| MINANGLE TOO LOW | The MINANGLE value was less than 5 counts. The MINANGLE value must be a number more than or equal to 5. | <ul style="list-style-type: none"> • Check the Angle Sensor to ensure it is installed properly. • Ensure that the Angle Sensors lever arm is installed properly. |
| INVALID RANGE | The sensors range from the platform stowed position to the platform's maximum elevation position was not acceptable. | <ul style="list-style-type: none"> • "Check the Angle Sensor to ensure it is installed properly. • "Ensure that the Angle Sensors lever arm is installed properly. |
| CAL FAIL! | The technician has pressed ESC on the Analyzer during the calibration routine | |

4.6 LOAD SENSING SYSTEM CALIBRATION (RS ONLY)

To access the Calibration Load Menu, use the LEFT and RIGHT Arrow keys to select CALIBRATION from the Top Level Menu. Press the ENTER key to select the menu.

Press the LEFT and RIGHT arrow keys to select LOAD from the CALIBRATION menu. Press the ENTER key to view the submenu. Should the Analyzer read CAL LOAD:FAIL at any time during the calibration procedure, reference the table below for the failure listed by the Analyzer.

NOTE: The Calibration Menu is not available in Access Level 2.

NOTICE

PRIOR TO LOAD SENSING SYSTEM CALIBRATION ENSURE THAT THE MACHINE HAS BEEN PLACED ON LEVEL GROUND, THE HYDRAULIC FLUID IS WITHIN THE ACCEPTABLE RANGE, THE TEMPERATURE IS GREATER THAN 32 DEGREES F, AND THE BATTERIES ARE FULLY CHARGED.

Upon entry to the Calibration, LOAD Menu, the analyzer will display:

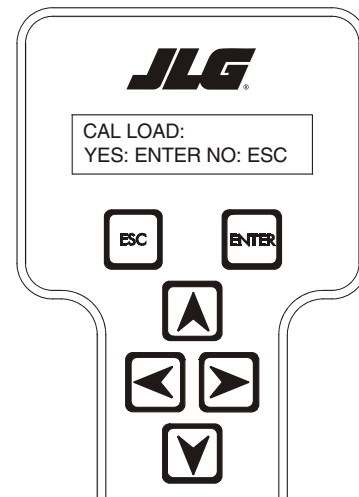

CAL LOAD:
YES:ENTER, NO:ESC

Pressing the ESC key at any time will return the user to the top level menu and not disturb the prior calibration information.

Pressing the Enter key will ensure that appropriate Calibration Weight, 110% rated load, has been placed in the

SECTION 4 - OPERATION - (RS)

center of the platform. The Analyzer will display the following.

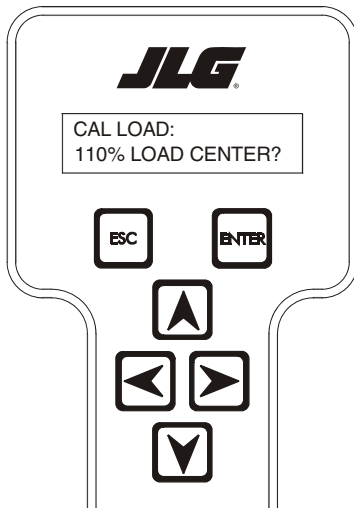

CAL LOAD:
110%LOAD,CENTER?

Pressing the Enter Key again will make the Analyzer display the following which means engage lift up from the ground panel until the platform reaches maximum elevation.

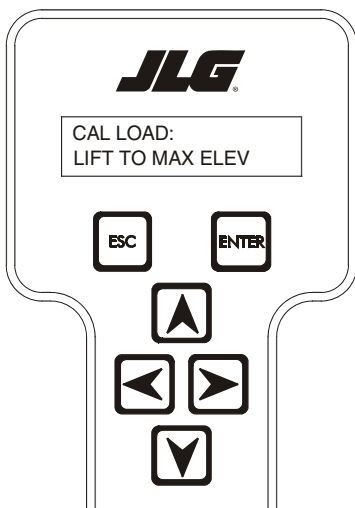

CAL LOAD:
LIFT TO MAX ELEV

Pressing the Enter key again will make the Analyzer display the following which means engage lift down until the platform becomes stowed.

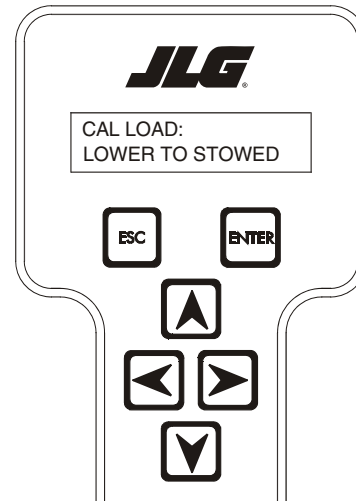

CAL LOAD:
LOWER TO STOWED

If the Load Calibration is successful the Analyzer will display the following.

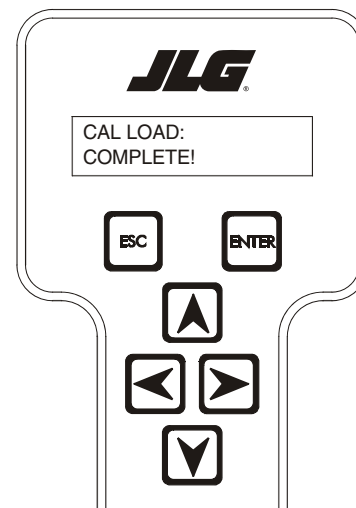

CAL LOAD:
COMPLETE!

Table 4-5. Load Calibration Failure Troubleshooting (RS Only)

| LOAD CALIBRATION FAILURE (Displayed on Analyzer 2nd Line) | DESCRIPTION | CHECK |
|--|--|--|
| NOT IN GND MODE | The machine is not in Ground Mode. | <ul style="list-style-type: none"> • Set the key switch so that the machine is in Ground Mode. • The machine must be in ground Mode for Load calibration. |
| CAL ANGLE | The Angle Sensor has not been calibrated. | <ul style="list-style-type: none"> • Navigate to the Calibrations menu and enter the Angle submenu to perform Angle Sensor calibration. • The Angle sensor must be calibrated before Load calibration can occur. |
| PLAT NOT STOWED | The machines platform is not stowed. | <ul style="list-style-type: none"> • Ensure that the platform is stowed and perform the Load calibration again. |
| MOTION STOPPED | The platform stopped moving during calibration. | <ul style="list-style-type: none"> • The technician let go of the lift up switch before the machine reached maximum elevation during "CAL LOAD: LIFT TO MAX ELEV". |
| CAL FAIL | The technician has pressed ESC on the Analyzer during the calibration routine. | |

SECTION 5. SERVICE - (LE, MRT, RTS, ES, RT)

5.1 DESCRIPTION

The system consists of the LSS Module, four Shear Pin Load Cells (sensors), Wire Harness, and various brackets and fasteners. The LSS Module is mounted beneath the platform on a bracket. The Shear Pin Load Cells mount

between the platform and the arm structure in such a way that all support force for the platform is applied through them (for measurement). The four Shear Pin Load Cells plug directly into the LSS Module. The Wire Harness connects the LSS Module to the Host Control System.

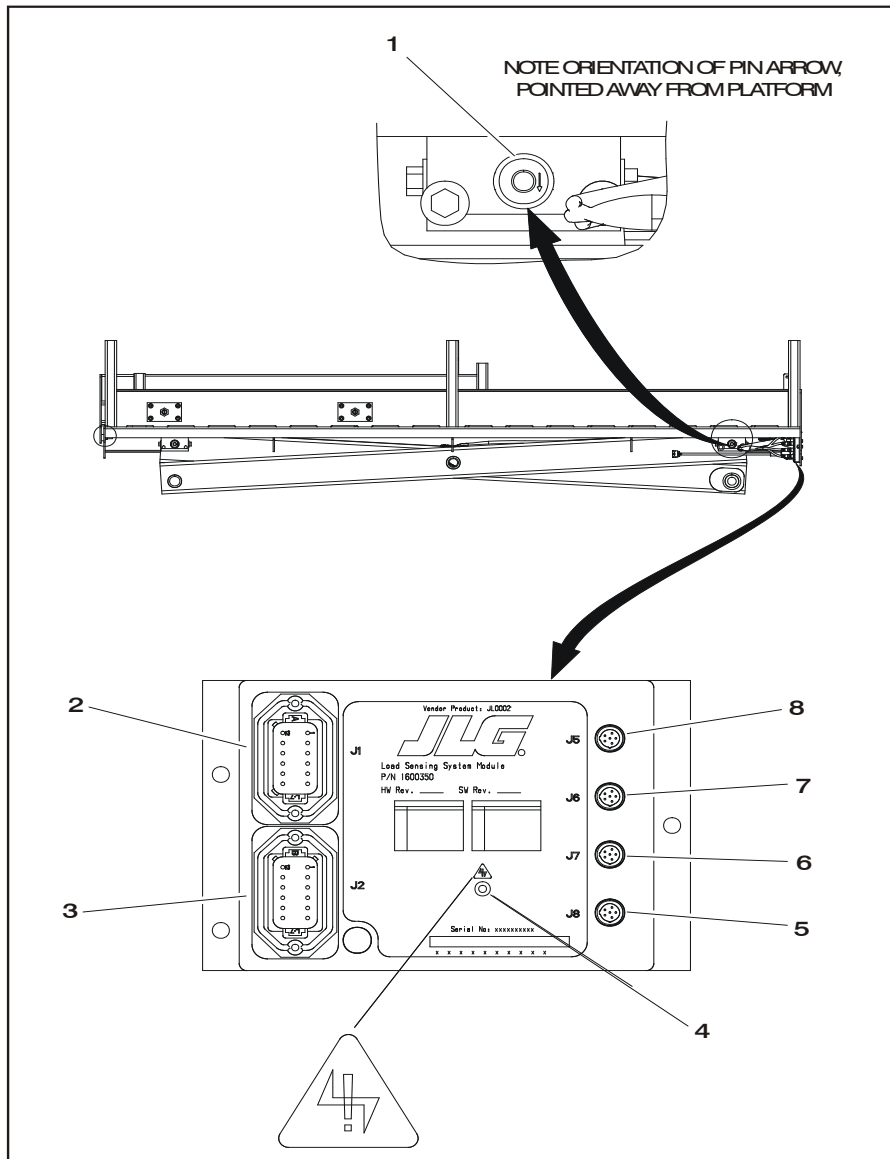

- | | |
|--|-------------------------------|
| 1. Load Cell (Typical 4 Corners) | 5. Rear Right Load Cell - J8 |
| 2. System Interface - Power & Digital - J1 | 6. Rear Left Load Cell - J7 |
| 3. System Interface Communication - J2 | 7. Front Right Load Cell - J6 |
| 4. Indicator Light | 8. Front Left Load Cell - J5 |

Figure 5-1. Load Sense Module

5.2 CALIBRATION

Procedure

1. Plug the JLG Analyzer into the LSS Module on the LE, MRT and RTS or the Host Control System on the ES and RT and enter the Access Level 1 Password. Do not confuse the Host Control System and LSS Module's Analyzer Connections. Proceed to the ACCESS LEVEL menu and enter the Access Level 1 Password (33271).
2. Park the vehicle on a level surface. The platform should be fully stowed and level within $\pm 5^\circ$ (both directions).
3. Configure the LSS Module for the proper model and Desired Units. On LE, MRT and RTS, proceed to the LSS Module's MACHINE SETUP, MODEL sub-menu and select "MODEL=4069LE, 3369LE, 500RTS, or 260MRT". Press the RIGHT ARROW to view the Units Selection. Select "UNITS=LBS" for platform load measurement in Pounds, and "UNITS=KG" for measurement in Kilograms.

NOTICE

EARLY RT'S REQUIRE A CONFIGURATION TO THE LSS MODULE. PLUG THE JLG ANALYZER INTO THE MODULE'S CONNECTION BENEATH THE DECK AND ENTER THE ACCESS LEVEL 1 PASSWORD (33271). UNDER MACHINE SETUP ENSURE THAT MODEL=260MRT.

4. Remove everything except JLG Accessories from the Platform. Empty the platform to allow the Load Sensing System to record its weight during calibration. All tools, debris, and customer-installed devices shall be removed. Permanently-fixed JLG Accessories shall remain and their contribution toward Rated Load will be accounted for in the next step.
5. Configure the LSS Module for JLG Accessories. The contribution of each permanently-fixed JLG Accessory toward Rated Load must be determined. JLG Accessories are decal'd with their effective contribution toward Rated Load. If this decal is missing, reference the appropriate manual for the JLG Accessory. Once determined, the contributions of all permanently-fixed JLG Accessories mounted in the platform of the vehicle shall be **added together** and entered in the Analyzer's PERSONALITIES, ACC'Y display (using the proper units).

6. Execute a Calibration via the JLG Analyzer. Proceed to the Analyzer's CALIBRATION top level menu and press ENTER. Press ESC to abort a calibration or ENTER to calibrate (tare). If successful, the Analyzer will display "COMPLETE". If unsuccessful, a message will be displayed that will help lead to a resolution (reference the Troubleshooting section of this manual). Press ESC to return to the top level menu.

Testing & Evaluation

Refer to the Troubleshooting section of this manual if the Load Sensing System fails to meet these guidelines.

1. Plug the JLG Analyzer into the LSS Module (LE, MRT and RTS) or the Host Control System (ES and RT).
2. Park the vehicle on a level surface. The platform should be fully stowed and level within $\pm 5^\circ$ (both directions).
3. Observe the Empty Platform Weight. Proceed to the DIAGNOSTICS, PLTLOAD sub-menu and observe the measured platform load. All tools, debris, and customer-installed devices shall be removed during evaluation. Ideally, the PLTLOAD should be zero but can vary $\pm 15\text{lbs}$ ($\pm 7\text{kg}$). Further, the reading should be stable and should not vary by more than $\pm 2\text{lbs}$ ($\pm 1\text{kg}$) (unless there is heavy influence from wind or vibration).
4. Use the Technician's Weight to Evaluate. The technician should enter the platform and record the PLTLOAD reading while standing in the center of the platform, and then each corner. The average of the readings should be the estimated weight of the technician. The range of the readings should be no more than 40lbs (18kg) (max PLTLOAD reading – min PLTLOAD reading).

5. Confirm Host Control System Warnings and Interlocks. Using the vehicle's keyswitch, select Platform Mode and power-up. Start the vehicle's engine (if equipped) and ensure that all controls are functional and the Load Sensing System's Overload Visual and Audible Warnings are not active. Simulate an Overload by unplugging the Shear Pin Load Cell connected to J5 on the LSS Module. The Overload Visual Warning should flash, and the Audible Warning (at Platform and Ground) should sound for 5 seconds On, and 2 seconds Off. With the engine running (if equipped), all platform control should be prevented. Cycle the Platform EMS to stop the engine and then power-up again. The Overload Visual and Audible Warning should continue. Install the disconnected Shear Pin Load Cell back in J5 on the LSS Module. The Overload Visual and Audible Warnings should cease and normal control function should return. Switch the vehicle's keyswitch to Ground Mode and repeat the above procedure. The Overload Visual Warning at the Ground Controls should flash, and the Audible Warning (at Platform and Ground) should sound for 5 seconds On, 2 seconds Off. However, the controls should remain functional when using the engine (if the Host Controls System's MACHINE SETUP, LOAD is set to "2=CUT-OUT PLT". If set to "3=CUTOOUT ALL", then Ground Controls will be prevented when using the platform). Re-fit the Shear Pin Load Cell connector to J5 on the LSS Module and carefully tighten by hand, and then with a small pair of locking pliers to seat the O-ring seal.
6. Confirm Load Sensing System Performance with Calibrated Weights. Operate the vehicle from Ground Control and place the platform in the fully stowed position for safety. Place 120% of the machine's rated load in the center of the platform and ensure that the overload visual and audible warnings are active. Reduce the platform load to 100% rated load and ensure that the warnings are not active. For vehicles with multiple capacities, evaluate each operating mode with the proper rated load.

5.3 TROUBLESHOOTING

as General, Calibration, Measurement Performance, and Host System Functionality.

The following tables are furnished to provide possible resolutions for common difficulties. Difficulties are classified

Table 5-1. LSS Troubleshooting Chart - General

| Difficulty | Possible Resolution |
|--|---|
| <p>JLG Analyzer does not display “HELP: PRESS ENTER” when connected to LSS Module’s connection, but the module’s LED is lit or flashing.</p> | <p>The JLG Analyzer is failing to communicate with the LSS Module, but the LSS Module is powered (indicated by module’s LED). Investigate JLG Analyzer serial communication and power supply connections.</p> <ol style="list-style-type: none"> 1. If the Analyzer displays “CONNECTING...” or “CONNECTION ERROR” after a short interval, examine the Analyzer harness on J2. J2-2 should connect to Pin 3 on the Analyzer, and J2-11 should connect to Pin 2. 2. If the Analyzer does not display anything (and there is no backlighting), examine the Analyzer’s power supply. Remove the harness connection from J2 and ensure that J2-1 has approximately 12V, and J2-12 is 0V. The harness should connect J2-1 to Pin 1 on the Analyzer, and J2-12 to Pin 4 on the Analyzer. 3. The JLG Analyzer is suspect. Substitute to determine cause of failure. 4. The LSS Module is suspect. Substitute to determine cause of failure. |
| <p>LED on LSS Module does not light.</p> | <p>The LSS Module is un-powered, a short exists, or the device is damaged.</p> <ol style="list-style-type: none"> 1. LSS Module’s power supply is improper. Check for the presence of approximately 12V on J1-1, and 0V on J1-2. The module’s power supply comes from the Platform Console Box. Use to the Wiring Diagram to trace the conductors to their source. 2. There is a short circuit on the reference voltage present on J5-J8. Unplug the connectors one at a time and observe if the module begins to function after a particular connection is removed. If so, carefully inspect the wiring between the module and that sensor. 3. There is a short circuit on the pre-regulated supply for the JLG Analyzer present on J2-1. Unplug J2’s connector and observe whether the module begins to function. If so, examine the Analyzer harness for defect. 4. The LSS Module is suspect. Substitute to determine cause of failure. |

Table 5-2. LSS Troubleshooting Chart - Calibration

| Difficulty | Possible Resolution |
|--|--|
| <p>JLG Analyzer displays “<MIN CAL” after attempt is made to Calibrate.</p> | <p>The LSS Module expected the empty platform to weight more for calibration.</p> <ol style="list-style-type: none"> 1. The platform is being supported by something other than the four Shear Pin Load Cells. This includes binding between the slide block/spacer bushing/arm tube assembly (bushing should be free enough to rotate by hand). For proper operation, the platform’s entire weight must be transferred through the Shear Pin Load Cells and into the arm support structure for an accurate calibration. 2. The wrong Model Selection was made under the LSS Module’s MACHINE SETUP, MODEL. This should be set to the proper MODEL (4069LE, 3369LE, 500RTS, 260MRT or SCISSOR). Improper selection may lead the LSS Module to expect different empty platform weights. 3. The calibration difficulty may be a result of a Measurement Performance issue. Review the Possible Resolutions under that category. |
| <p>JLG Analyzer displays “>MAX CAL” after attempt is made to Calibrate.</p> | <p>The LSS Module expects the empty platform to weigh less for calibration.</p> <ol style="list-style-type: none"> 1. Tools, debris, or customer-installed accessories have not been removed before calibration. The LSS Module must tare an empty platform and its optional JLG Accessories. 2. The wrong Model Selection was made under the LSS Module’s MACHINE SETUP, MODEL. This should be set to MODEL (4069LE, 3369LE, 500RTS, or 260MRT). Improper selection may lead the LSS Module to expect different empty platform weights. 3. The calibration difficulty may be a result of a Measurement Performance issue. Review the Possible Resolutions under that category. |

Table 5-3. LSS Troubleshooting Chart - Measurement Performance

| Difficulty | Possible Resolution |
|--|--|
| <p>Empty Platform Weight (DIAGNOSTICS, PLTLOAD) is not within ± 15lbs (± 7kg) of zero.</p> <p style="text-align: center;">or</p> <p>Platform Load readings (DIAGNOSTICS, PLTLOAD) are unstable by more than ± 2lbs (± 1kg) (without the influence of vibration or wind).</p> <p style="text-align: center;">or</p> <p>There are large variations in Platform Load (DIAGNOSTICS, PLTLOAD) based on the location of the load. Tolerance to variations is 40lbs (18kg) for an evaluation using the technician's weight, and $\pm 5\%$ of Rated Load when using calibrated weights.</p> | <p>The LSS Module is unable to properly measure the platform weight.</p> <ol style="list-style-type: none"> 1. One of the Shear Pin Load Cells is not properly plugged into the LSS Module. Since the connectors seal with an O-ring and are located in a crowded area, it is possible that the connectors are threaded together, but poor electrical contact is made. Attempt to wiggle the molded portion of each connector on J5-J8. If properly tightened, the molded portion should not move. Also, examine each Shear Pin Load Cell's readings via the JLG Analyzer. Proceed to the DIAGNOSTICS, CELL 1-4, LOAD displays and determine if the readings are reasonable. Note that it is possible to have only two sensors carrying all of the platform load due to fit between the platform and support structure (this is normal). 2. Wiring leading to one of the Shear Pin Load Cells is damaged. Examine each sensor's reading using the JLG Analyzer. Proceed to the DIAGNOSTICS, CELL 1-4, LOAD displays and determine if the readings are reasonable and responsive to slight downward pressure above the sensor being viewed. Carefully inspect sensor wiring where it passes through cable clamps for signs of damage. Inspect wiring where damage to the channel is apparent. If damage to the sensor's cordset is found, replace the appropriate Shear Pin Load Cell since the cordset is not serviceable (connector is molded for moisture resistance; cordset is soldered into sensor beneath welded stainless steel cover). If damage to the sensors extension cordset is found, unplug both ends and fit a replacement. 3. One of the Shear Pin Load Cells was not assembled properly during installation. Examine each sensor's reading using the JLG Analyzer. Proceed to the DIAGNOSTICS, CELL 1-4, LOAD displays and determine if the readings are reasonable. It is often helpful to apply slight downward pressure above the sensor being examined and observe that its output increases (increasing force measurement; decreasing means the sensor is mounted upside-down). Compare the order of assembly to the detail on the Installation Drawing and ensure that the only contact between the platform and the support is through the sensor bodies (nothing else touches except wires). Re-assemble according to print if necessary. <p>(continued)</p> |

Table 5-3. LSS Troubleshooting Chart - Measurement Performance

| Difficulty | Possible Resolution |
|------------|--|
| | <ol style="list-style-type: none"> <li data-bbox="581 323 1531 495">4. Damage to the platform or arm structure has occurred or one of the components is out-of-tolerance. Twists in the platform, for instance, will cause huge off-axis forces to be applied to the Shear Pin Load Cells, disturbing their primary measurement axis readings. If Lift Up / Down is noisy or not smooth, examine this issue thoroughly. Resolution is to replace the damaged or faulty component. Watch for Shear Pin Load Cell damage (yield) as a result of this difficulty. <li data-bbox="581 510 1531 884">5. One of the Shear Pin Load Cells is contaminated by debris or moisture. Examine each sensor's reading using the JLG Analyzer. Proceed to the DIAGNOSTICS, CELL 1-4, LOAD displays and determine if the readings are reasonable and stable (not changing by more than ± 2lbs (± 1kg)) (without the influence of vibration or wind). Lack of measurement stability is a key indication of contamination. Unplug the appropriate connector (J5 is CELL 1, J6 is CELL 2, J7 is CELL 3, and J8 is CELL 4) and inspect for dirt or moisture. Look carefully into the female connector on the sensor's cordset for evidence of contamination. Debris should be brushed away with a soft bristle brush (do not introduce any cleaners as they will leave conductive residue). Moisture should be allowed to evaporate or accelerated with a heat-gun (use low heat and be carefully to not melt connector materials). Moisture intrusion into the molded portion of the connector (capillary action into the wire bundle) or the Shear Pin Load Cell itself will require replacement of the sensor. <li data-bbox="581 898 1531 1188">6. One of the Shear Pin Load Cells has been mechanically damaged (yielded). Any Shear Pin Load Cell that is physically deformed or has damage to one of the stainless steel covers should be replaced immediately. It is also possible to have invisible mechanical damage resulting from an extreme overload (>4200lbs [>1900kg] for 1.25 in diam.; >5700 lbs or 2600 KG for 2 inch diam.). This can be detected by supporting the platform with an overhead crane and by removing the suspect sensor (no weight resting on the Shear Pin Load Cell). Examine the sensor's reading using the JLG Analyzer. Proceed to the DIAGNOSTICS, CELL 1-4, LOAD displays and observe whether the unloaded sensors read with ± 15lbs (± 7kg) of zero (individually). Replace sensors that read excessive force when physically unloaded. <li data-bbox="581 1203 1531 1346">7. The LSS Module is suspect. Interchange the Shear Pin Load Cell connections (J5-J8) and observe the results via the JLG Analyzer. Proceed to the DIAGNOSTICS, CELL 1-4, LOAD displays and observe the readings. If the problem seems to remain with a particular sensor, carefully re-examine the issues above. If the problems seems to remain with a particular LSS Module channel, substitute another module. |

Table 5-4. LSS Troubleshooting Chart - Host System Functionality

| Difficulty | Possible Resolution |
|--|--|
| <p>The Visual and Audible Overload Warnings fail to sound when platform is loaded beyond Rated Load, or when simulated by unplugging a Shear Pin Load Cell from the LSS Module. Controls remain functional at Platform and Ground Control positions.</p> | <p>The Host Control System is failing to regard the overload signal from the LSS Module, or the signal is shorted.</p> <ol style="list-style-type: none"> 1. The Load Sensing System must be enabled within the Host Control System. Plug the JLG Analyzer into the Host Control System, enter the Access Level 1 password (33271), and examine the MACHINE SETUP, LOAD sub-menu. The selection "CUT-OUT PLT" should be displayed for European Community compliance (platform controls prevented during overload, ground controls remain operational). In country- or customer-specific circumstance, the selection "3=CUTOOUT ALL" is used (platform and ground controls prevented during overload). 2. (LE, MRT and RTS) - The signal between the LSS Module and the Host Control System is shorted. The Platform Module's J1-20 is an input, and it connected to the J1-5 output on the LSS Module To examine the status of this signal, plug the JLG Analyzer into the Host Control System, enter the Access Level 1 password (33271), and examine the DIAGNOSTICS, SYSTEM, LOAD display. The display will indicate "OK" when the Platform Module's input is energized (approximately 12V), and "OVERLOADED" when it is de-energized (0V). Refer to the Wiring Diagram for Load Sensing System for details 3. Observe the LSS Module's assessment of overload using the JLG Analyzer plugged into the LSS Module's connection. Proceed to the DIAGNOSTICS, OVERLOADED? display. The display should indicate "OVERLOADED? N" when the platform is empty, and "OVERLOADED? Y" when the platform is overloaded. If the assessment is improper, the difficulty may be a result of a General or Measurement Performance issue. Review the Possible Resolutions under those categories. 4. (LE, MRT and RTS) - If the LSS Module's J1-5 Output does not appears to coincide with the DIAGNOSTICS, OVERLOADED? display, then the LSS Module is suspect. Substitute to determine cause of failure. |

Table 5-4. LSS Troubleshooting Chart - Host System Functionality

| Difficulty | Possible Resolution |
|---|---|
| <p>The Visual and Audible Overload Warnings sound even when the platform is empty. Controls are prevented in the same manner as when overloaded.</p> | <p>The LSS Module is un-powered, un-calibrated, or is experiencing a Measurement Performance difficulty. Alternately, the Host Control System is not receiving the proper signal from the LSS Module.</p> <ol style="list-style-type: none"> 1. Ensure that the LSS Module is powered. The LSS Module's LED will be lit or flash if the module is powered. If not, ensure that approximately 12V is present between J1-1 and J1-2 on the LSS Module (J1-1 is positive). Trace the Ignition and Ground supply wires into the Host Control System's wiring harness using the wiring diagram to locate the difficulty. 2. Plug a JLG Analyzer into the LSS Module's connection and ensure that the Host Control System is powered-up. When HELP:PRESS ENTER is displayed, press the ENTER key on the Analyzer. If "EVERYTHING OK" is displayed, it is probable that the Overload Signal from the LSS Module is not reaching the Host Control System. This signal is present on LSS Module's J1-5 and is approximately 12V normally, and 0V during an overload. This signal eventually reaches the Main Terminal Box to provide the overload signal. Refer to the Wiring Diagram for wire color, number, and terminal information. 3. (LE, MRT and RTS) - If the Analyzer displayed "OVERLOADED" in the previous step, press the ENTER key again. If "NO CAL" is displayed, the Load Sensing System has not been properly calibrated. Refer to the Calibration portion of this manual. 4. If another fault is displayed, refer to the portion of this manual that describes Fault Messages and their causes. 5. The difficulty may be a result of a Measurement Performance issue. Review the Possible Resolutions under those categories. |
| <p>Controls remain functional at the Ground Control position during an overload, or when simulated by unplugging a Shear Pin from the LSS Module. The Control at the Platform Control position are prevented.</p> | <p>The Host Control System is configured to prevent platform controls only in the event of overload (as required for EN280 compliance). Alternately, the Host Control System can be configured to prevent ground and platform controls for country- or customer-specific circumstances.</p> <p>Plug the JLG Analyzer into the LSS Module's connection and enter the Access Level 1 password (33271). Proceed to the MACHINE SETUP, LOAD sub-menu. Set this parameter to "CUTOUT PLT" to prevent platform controls in the event of overload. Set this parameter to "CUTOUT ALL" to prevent platform and ground controls in the event of overload.</p> |

SECTION 5 - SERVICE - (LE, MRT, RTS, ES, RT)

Table 5-5. LSS Module System Interface Connector - Power & Digital (J1 - Grey)

| Pin | Signal | Description |
|-----|--------|--|
| 1 | VBAT | Positive Power Supply from Host Control System (12-24V) |
| 2 | GND | Negative Power Supply from Host Control System (0V) |
| 3 | GND-2 | Connects to GND |
| 4 | N/C | Unused |
| 5 | DO1 | Overload Indicator Output (Normal=VBAT / Overload=0V) |
| 6 | DO2 | Warning Indicator Output (Normal=0V / Overloaded=VBAT for 5 Sec, 0V for 2 Sec) |
| 7 | DI3 | Unused |
| 8 | DI2 | Select OVERLD3 Personality Rating (No=0V / Yes=VBAT) |
| 9 | DI1 | Select OVERLD2 Personality Rating (No=0V / Yes=VBAT) |
| 10 | GND-2 | Connects to GND |
| 11 | VBAT-2 | Connects to VBAT |
| 12 | VBAT-2 | Connects to VBAT |

Table 5-6. LSS Module System Interface Connector - Communication (J1 - Black)

| Pin | Signal | Description |
|-----|--------|---|
| 1 | APWR | Pre-Regulated Supply for JLG Analyzer (Analyzer Pin 1; approx. 12V) |
| 2 | TX | RS-232 for JLG Analyzer (Analyzer Pin 3) |
| 3 | TRP1 | 120 Ohm CANbus Terminator |
| 4 | CANH-1 | CANbus Interface High |
| 5 | CANS-1 | CANbus Shield Termination (Not same as GND) |
| 6 | CANH-2 | Connects to CANH-1 |
| 7 | CANL-2 | Connects to CANL-1 |
| 8 | CANS-2 | Connects to CANS-1 |
| 9 | CANL-1 | CANbus Interface Low |
| 10 | TRP2 | 120 Ohm CANbus Terminator |
| 11 | RX | RS-232 for JLG Analyzer (Analyzer Pin 2) |
| 12 | GND | Ground for JLG Analyzer (Analyzer Pin 4) |

Table 5-7. LSS Module Load Cell Connector Pinout (J5, J6, J7, J8)

| Pin | Signal | Description |
|-----|--------------|---|
| 1 | + Signal | Positive Sensor Output (approx. 2.5V) |
| 2 | Cal Clock | Serial Clock to Sensor's Integrated Memory |
| 3 | - Excitation | Negative Sensor Supply Voltage (approx. 0V) |
| 4 | +Excitation | Positive Sensor Supply Voltage (approx. 5V) |
| 5 | -Signal | Negative Sensor Output (approx. 2.5V) |
| 6 | Cal Data | Serial Data from Sensor's Integral Memory |

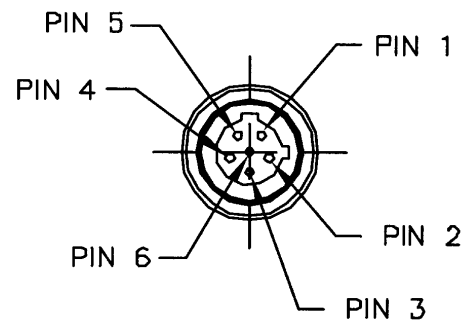

NOTE: Physical connector as viewed looking into the cable end

Figure 5-2. LSS Module Load Cell Connector Pinout (J5, J6, J7, J8)

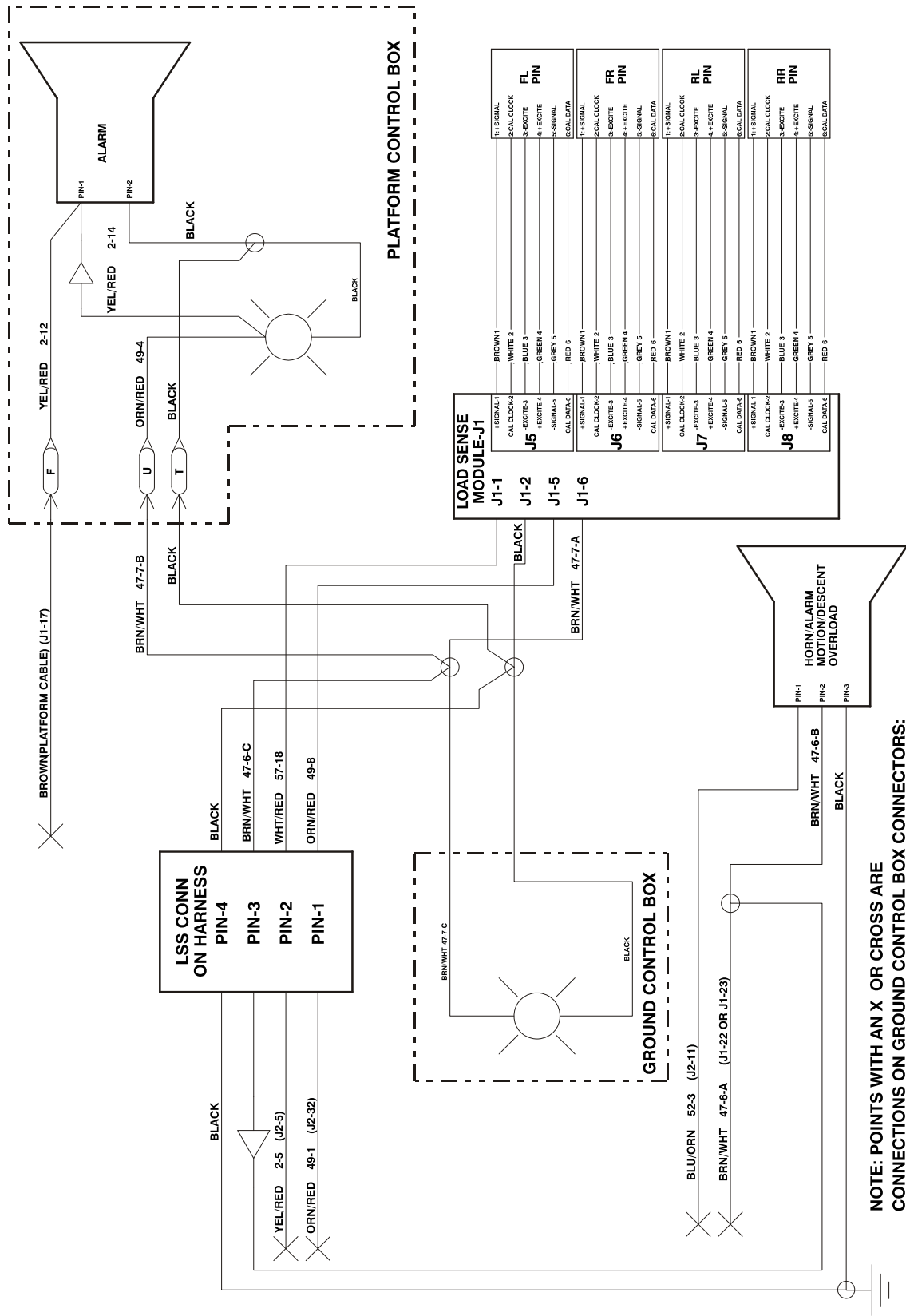

NOTE: POINTS WITH AN X OR CROSS ARE CONNECTIONS ON GROUND CONTROL BOX CONNECTORS: J1 BEING THE 24 PIN J2 BEING THE 40 PIN

1870168 A

Figure 5-3. 260MRT Wiring Diagram

SECTION 5 - SERVICE - (LE, MRT, RTS, ES, RT)

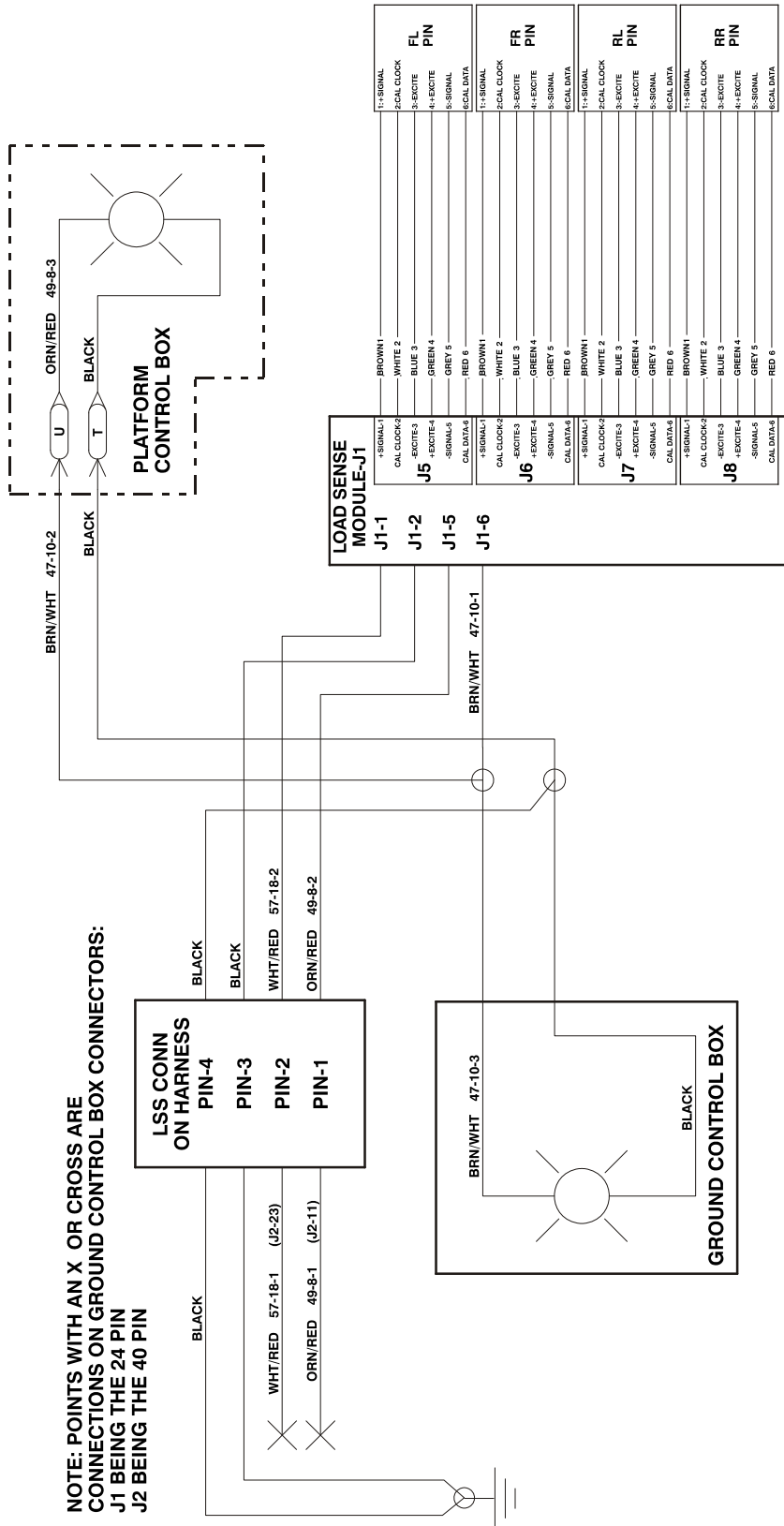

1870169 A

Figure 5-4. M3369/M4069 & 3369LE/4069LE Wiring Diagram

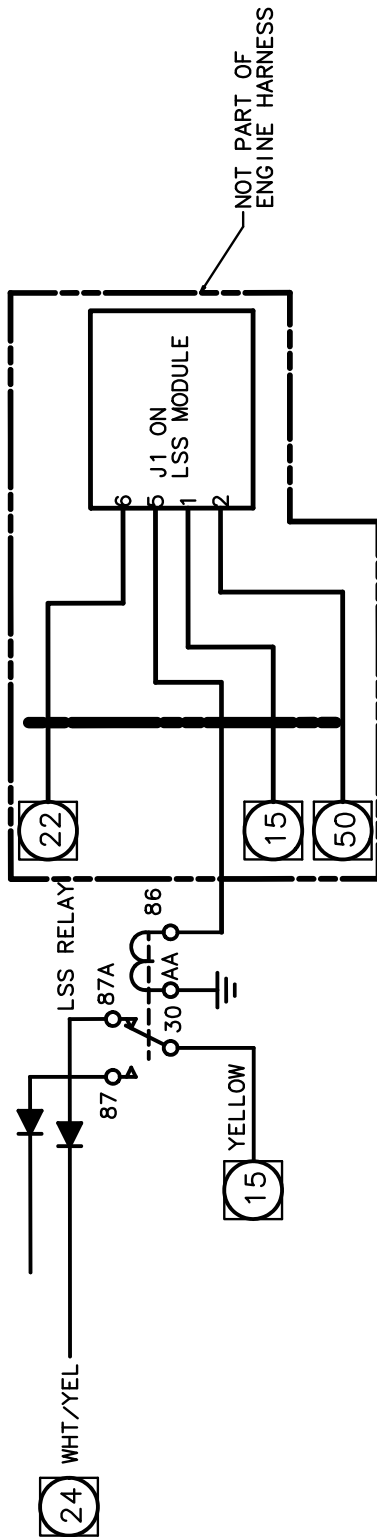

1283361 C

Figure 5-5. 500RTS Wiring Diagram

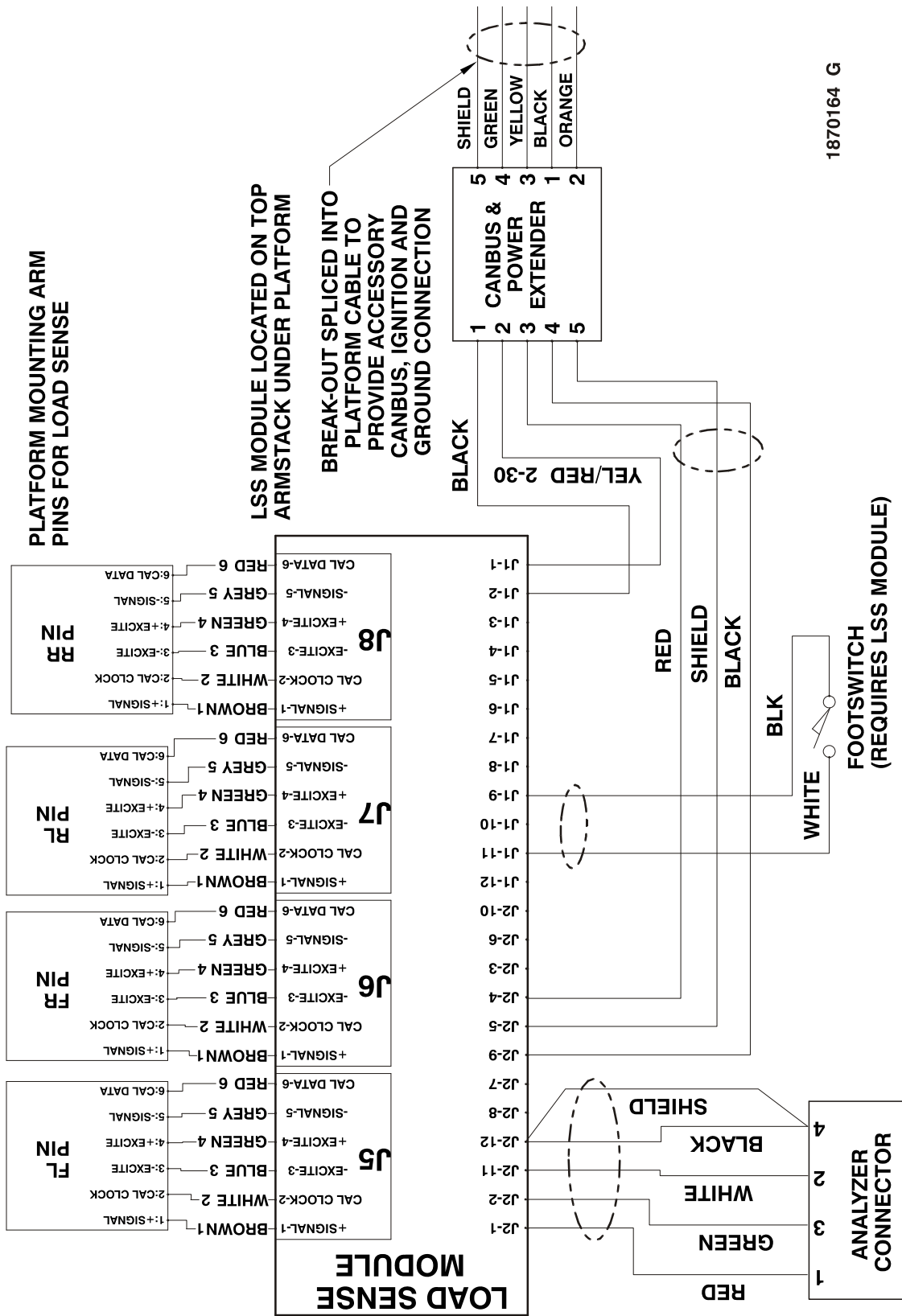

1870164 G

Figure 5-6. ES Wiring Diagram

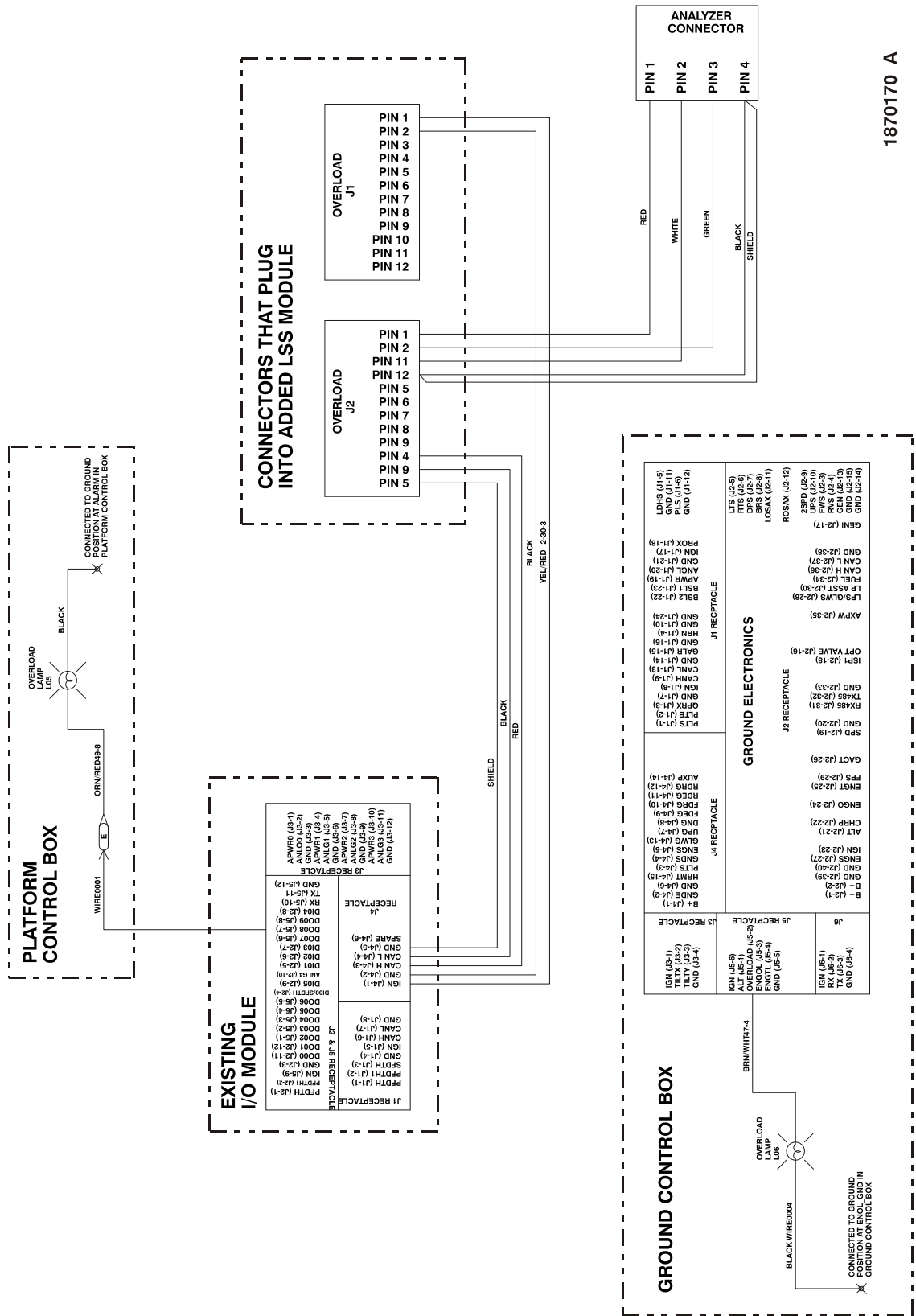

Figure 5-7. RT Wiring Diagram

SECTION 6. SERVICE - (RS)

6.1 DESCRIPTION (RS)

The platform load sensing system is intended to prevent machine operation in the event that the platform is overloaded. Machine operation does not return until the platform overload is removed. If the platform load sensing system is equipped the machine will include 3 additional components, 2 pressure transducers and 1 angle sensor.

The pressure transducers, which are located at the barrel end of the lift cylinder, (See Figure 6-1. and Figure 6-2.) are intended to correlate hydraulic fluid pressure to the load placed in the platform. The angle sensor, located at the bottom of the arm stack to the rear of the 10RS, and underneath the platform at the rear of the machine on the 6RS, (See Figure 6-3.) is intended to correlate machine elevation with hydraulic fluid pressure as measured by the pressure transducers.

NOTE: JLG specifications require that this procedure be performed every 500 machine hours or 6 months, whichever occurs first. Calibrating the platform load sensing system regularly is essential to safe machine operation. Continuing to operate a machine without calibrating at the recommended specifications could compromise machine stability resulting in a machine tip-over.

6.2 CALIBRATION (RS)

The load sensing system cannot be calibrated without first calibrating the machines Angle Sensor. The load sensing system will not measure load at or below the elevation switch trip point.

Angle Sensor Calibration Procedure (RS)

1. Ensure the batteries are fully charged and the hydraulic fluid level is acceptable.
2. Park the vehicle on a level surface. The platform should be fully stowed and level within +/- 0.5 degrees (both directions).
3. Remove the orange panel on the ground control key switch side of the machine.
4. Disconnect the MDI display and connect the JLG Analyzer.
5. Navigate to the ACCESS LEVEL menu on the Analyzer and enter the Access Level 1 code.
6. Execute a Angle Calibration via the JLG Analyzer. Proceed to the Analyzer's CALIBRATION top level menu and press ENTER. Navigate to the ANGLE submenu and press ENTER. Press ESC to abort a calibration or ENTER to calibrate. If successful the Analyzer will display COMPLETE!. If unsuccessful, a message will be displayed that will help lead to a

resolution (reference the Troubleshooting section of this manual). Press ESC to return to the top level menu.

Platform Load Sensing System Calibration Procedure (RS)

1. If the Angle Sensor has not been calibrated refer to the Angle Sensor Calibration Procedure first!
2. Ensure the batteries are fully charged and the hydraulic fluid level is acceptable.
3. Park the vehicle on a level surface. The platform should be fully stowed and level within +/- 0.5 degrees (both directions).
4. Ensure the temperature is greater than 32 degrees Fahrenheit.
5. Place weight corresponding to 110% of the machines rated load in the center of the platform. Secure the weight to the platform. See the chart below to determine the correct weight for calibration on each machine.

Table 6-1. Platform Calibration Weight - RS

| MACHINE | CALIBRATION WEIGHT |
|-------------|--------------------|
| 1932RS/6RS | 550 lbs. (250 Kg) |
| 3248RS/10RS | 775 lbs. (352 Kg) |

6. Remove the orange panel on the ground control key switch side of the machine.
7. Disconnect the MDI display and connect the JLG Analyzer.
8. Navigate to the ACCESS LEVEL menu on the Analyzer and enter the Access Level 1 code.
9. Execute a Load Calibration via the JLG Analyzer. Proceed to the Analyzer's CALIBRATION top level menu and press ENTER. Navigate to the LOAD submenu and press ENTER. Press ESC to abort a calibration or ENTER to calibrate. If successful the Analyzer will display COMPLETE!. If unsuccessful, a message will be displayed that will help lead to a resolution (reference the Troubleshooting section of this manual). Press ESC to return to the top level menu.

6.3 TESTING AND EVALUATION (RS)

Refer to the troubleshooting section of this manual if the Load Sensing System fails to meet these guidelines.

1. Park the vehicle on a level surface. The platform should be fully stowed and level within +/- 0.5 degrees (both directions).
2. Ensure Pressure Transducers work appropriately. Proceed to the DIAGNOSTICS, LOAD submenu and ensure that PRES1 and PRES2 are within 10 PSI of 0 with the platform stowed. Engage lift up from the ground panel and ensure that the PRES1 and PRES2 readings begin to increase as the machine elevates.
3. Ensure the Angle Sensor works appropriately. Proceed to the DIAGNOSTICS, ANGLE submenu and ensure that ANGLE, ANGLE increases as the machine elevates and decreases as the machine descends.
4. Confirm Host Control System Warnings and Interlocks and Load Sensing System Performance with Calibrated Weights. Using the vehicle's key switch select ground mode and power-up. Ensure that all controls are functional and the Load Sensing Systems Visual and Audible Warnings are not active. Engage lift up from the Ground Panel until the platform reaches maximum elevation, and then engage

lift down from the Ground Panel until the platform becomes stowed. Ensure that the Overload Visual and Audible alarm did not activate at either control position during this procedure. Ensure that the Load Sensing System activates with 120% rated load placed in the center of the platform. With the platform stowed engage lift up with 120% rated load placed in the center of the platform ensuring that the Load Sensing System activates within the ranges listed in the following table. Ensure that the DIAGNOSTICS, LOAD, OVERLOADED submenu reads YES. The Overload Visual Warning should flash at the selected control position and the Audible Warning should sound for 5 seconds On and 2 seconds Off. With the machine On all platform movement should be prevented. Cycle the Ground Panel Emergency Stop button. The Overload Visual and Audible Warning should continue. Pull the manual descent lever until the platform becomes stowed. The Overload Visual and Audible Warnings should cease and all normal control function should return.

Table 6-2. System Activation Height - RS

| MACHINE | SYSTEM ACTIVATION HEIGHT |
|----------------|---------------------------------|
| 1932RS/6RS | 4.92 - 8.20 ft. (1.5 - 2.5m) |
| 3248RS/10RS | 8.20 - 11.48 ft. (2.5 - 3.5m) |

6.4 LSS TROUBLESHOOTING (RS)

The following tables are furnished to provide possible resolutions for common difficulties.

Table 6-3. LSS Troubleshooting - RS

| PROBLEM | POSSIBLE RESOLUTION |
|--|--|
| JLG Analyzer displays "MAX NOT IN RANGE" after the step "LIFT TO MAX" during Angle Calibration | The Angle Sensor's upper limit is not acceptable. The Angle Sensor's reading must fall within +/- 35 counts of 210 counts when the platform is at maximum elevation. <ol style="list-style-type: none"> 1. Check the Angle Sensor to ensure that it is installed properly and that no debris has become lodged around the Angle Sensor lever arm. 2. Ensure that the lever arm is installed properly and is not damaged. |
| JLG Analyzer displays "MAXANGLE TO HIGH" after the step "LIFT TO MAX" during Angle Calibration | The Angle Sensor's reading when the platform is at maximum elevation was greater than 245 counts. The Angle Sensor's reading when the platform is at maximum elevation must be a number less than or equal to 245 counts. <ol style="list-style-type: none"> 1. Check the Angle Sensor to ensure that it is installed properly and that no debris has become lodged around the Angle Sensor lever arm. 2. Ensure that the lever arm is installed properly and is not damaged. |
| JLG Analyzer displays "LOW NOT IN RANGE" after the step "LOWER TO STOWED" during Angle Calibration | The Angle Sensors lower limit is not acceptable. The Angle Sensor's reading must fall within +/- 35 counts of 40 counts when the platform is stowed. <ol style="list-style-type: none"> 1. Check the Angle Sensor to ensure that it is installed properly and that no debris has become lodged around the Angle Sensor lever arm. 2. Ensure that the lever arm is installed properly and is not damaged. |
| JLG Analyzer displays "MINANGLE TOO LOW" after the step "LOWER TO STOWED" during Angle Calibration | The Angle Sensor's reading when the platform is stowed was less than 5 counts. The Angle Sensor's reading when the platform is stowed must be a number greater than or equal to 5 counts. <ol style="list-style-type: none"> 1. Check the Angle Sensor to ensure that it is installed properly and that no debris has become lodged around the Angle Sensor lever arm. 2. Ensure that the lever arm is installed properly and is not damaged. |
| JLG Analyzer displays "CAL FAIL!" at any time during the ANGLE calibration. | The technician has pressed ESC on the Analyzer during the calibration routine or the Angle Sensor's Range with the platform stowed to the platform at maximum elevation was not acceptable. <ol style="list-style-type: none"> 1. ESC was accidentally pressed during the Calibration procedure. The previously calibrated values will not be lost. Attempt ANGLE calibration again. 2. Check the Angle Sensor to ensure that it is installed properly and that no debris has become lodged around the Angle Sensor lever arm. 3. Ensure that the lever arm is installed properly and is not damaged. |
| JLG Analyzer displays "INVALID RANGE" after the step "LOWER TO STOWED" | The sensors range from stowed to maximum height was not acceptable. <ol style="list-style-type: none"> 1. Check to ensure that the Angle sensor is mounted properly. 2. Ensure that the angle sensors lever arm is still functioning properly and is not broken. |
| JLG Analyzer displays "NOT IN GND MODE" when attempting to perform a LOAD Calibration | The machine is not in Ground Mode. <ol style="list-style-type: none"> 1. Re-attempt LOAD Calibration after setting the key switch to the Ground Control position. |
| JLG Analyzer displays "CAL ANGLE" when attempting to perform a LOAD Calibration. | The Angle Sensor has not been calibrated. <ol style="list-style-type: none"> 1. The Angle Sensor must be calibrated before a LOAD calibration can occur. Enter the CALIBRATIONS menu and perform an ANGLE calibration. |

Table 6-3. LSS Troubleshooting - RS (Continued)

| PROBLEM | POSSIBLE RESOLUTION |
|---|---|
| <p>JLG Analyzer displays "MOTION STOPPED" after the LOAD calibration steps "LIFT TO MAX ELEV" or "LOWER TO STOWED".</p> | <p>The platform stopped moving during LOAD calibration.</p> <ol style="list-style-type: none"> 1. The technician let go of the lift up switch before the machine reached maximum elevation during "CAL LOAD: LIFT TO MAX ELEV" or the technician let go of the lift down switch before the machine became stowed after the "CAL LOAD: LOWER TO STOWED" step. Re-attempt LOAD calibration making sure not to disengage the lift up and lift down switch during these steps. |
| <p>JLG Analyzer displays "CAL FAIL!" when attempting to perform a LOAD Calibration.</p> | <p>The technician has pressed ESC on the Analyzer during the calibration routine.</p> <ol style="list-style-type: none"> 1. ESC was accidentally pressed during the Calibration procedure. The previously calibrated values will not be lost. Attempt LOAD calibration again. |
| <p>The Visual and Audible Overload Warnings fail to sound when platform is loaded beyond rated load. Controls remain functional at Ground and Platform Control Positions.</p> | <p>The Load Sensing System is failing to detect that an overload condition exists or the Load Sensing system has not been enabled.</p> <ol style="list-style-type: none"> 1. The Load Sensing System must be enabled within the Host Control System. Connect the JLG Analyzer and enter the Access Level 1 Password (33271). Navigate to MACHINE SETUP, LOAD submenu. The selection "CUTOUT PLT" should be displayed for European Community Compliance (platform controls prevented during overload, ground controls remain operational). In country- or customer-specific circumstances, the selection "CUTOUT ALL" is used (platform and ground controls prevented during an overload). 2. The Load Sensing System requires re-calibration. If the Load Sensing System fails to detect an Overload with 120% load placed in the platform perform an ANGLE calibration followed by a LOAD calibration as specified by the Calibration procedures listed in this document. 3. If a fault is displayed, refer to the portion of this manual that describes Fault Messages and their causes. |
| <p>The Visual and Audible Overload Warnings sound even when platform is empty. Controls are prevented in the same manner as when overloaded.</p> | <p>The Load Sensing System has not been calibrated or is experiencing a measurement performance difficulty.</p> <ol style="list-style-type: none"> 1. The machine is assumed to be overloaded until the Load Sensing System has been calibrated. Navigate to the CALIBRATIONS menu and perform an ANGLE calibration followed by a LOAD calibration. 2. The Load Sensing System requires re-calibration. If the Load Sensing System falsely detects an Overload with less than rated load placed in the platform perform an ANGLE calibration followed by a LOAD calibration as specified by the Calibration procedures portion of this manual. 3. If a fault is displayed, refer to the portion of this manual that describes Fault Messages and their causes. |
| <p>Controls remain functional at the Ground Control position during an overload. The Control at the Platform Control positions are prevented.</p> | <p>The Host Control System is configured to prevent platform controls only in the event of overload. Alternately, the Host Control System can be configured to prevent ground and platform controls for country- or customer-specific circumstances.</p> <ol style="list-style-type: none"> 1. Plug the JLG Analyzer in and enter the Access Level 1 password (33271). Proceed to the MACHINE SETUP, LOAD sub-menu. Set this parameter to "CUTOUT PLT" to prevent platform controls in the event of overload. Set this parameter to "CUTOUT ALL" to prevent platform and ground controls in the event of overload. |

6.5 LSS COMPONENT REMOVAL/ INSTALLATION (RS)

Pressure Transducer Removal (RS)

(See Figure 6-1. and Figure 6-2.)

Use the following procedure to safely remove and repair the pressure transducers on the lift cylinder.

1. Ensure that the key switch is set to ground mode.
2. Engage lift up from the ground panel until the platform has elevated high enough to engage the lift cylinder safety prop.
3. Engage the platform safety prop.
4. Lower the platform on to the safety prop and continue to engage lift down for 1 second after the platform makes contact with the safety prop.
5. Disconnect power at the batteries.
6. Carefully disconnect the electrical connectors on each sensor.
7. Remove each pressure transducer.

Pressure Transducer Installation (RS)

1. Insert new pressure transducer and tighten.
2. Reconnect each pressure transducers electrical connector.
3. Reconnect power at the batteries.
4. Turn machine on and engage lift up from the ground panel so that the safety prop can be disengaged.
5. Lower the platform to the stowed position.
6. This completes pressure transducer repair.

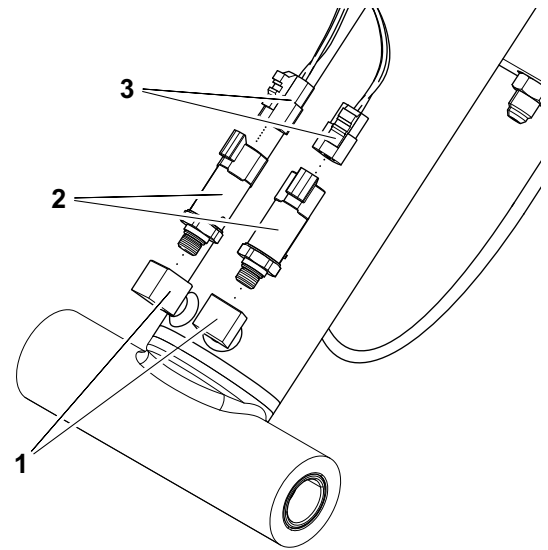

**Figure 6-1. LSS Pressure Transducer Location -
1932RS/6RS**

- | | |
|--------------------------------|-----------------------|
| 1. Ports On Barrel of Cylinder | 3. Harness Connectors |
| 2. Pressure Transducers | |

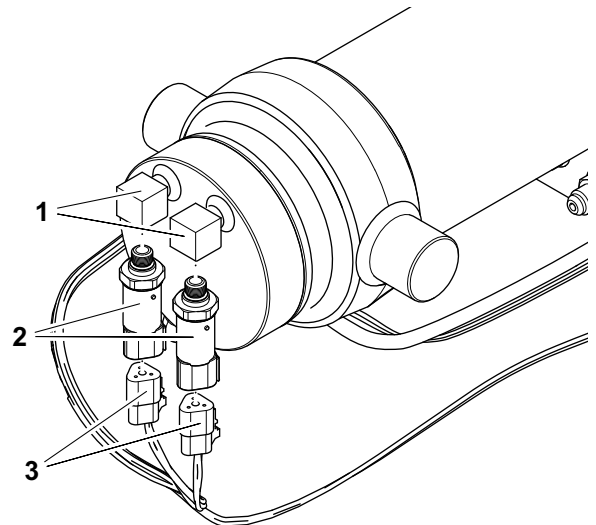

**Figure 6-2. LSS Pressure Transducer Location -
3248RS/10RS**

- | | |
|--------------------------------|-----------------------|
| 1. Ports On Bottom of Cylinder | 3. Harness Connectors |
| 2. Pressure Transducers | |

10RS Angle Sensor Removal (RS)

(See Figure 6-1. and Figure 6-2.)

1. Ensure that the platform is stowed and the machine is on level ground.
2. Disconnect power at the batteries.
3. Locate the Angle Sensor at the back of the machine.
4. Disconnect the Angle Sensor's electrical connection.
5. Remove the Angle Sensor.

10RS Angle Sensor Installation (RS)

1. Install the Angle Sensor with the mounting hardware.
2. Reconnect the Angle Sensor's electrical connector.
3. Reconnect power at the batteries.
4. Recalibrate the machine's Angle Sensor.
5. Recalibrate the machine's Load Sensing System.

6RS Angle Sensor Removal (RS)

1. Ensure that the key switch is set to ground mode.
2. Engage lift up from the ground panel until the platform has elevated high enough to engage the lift cylinder safety prop.
3. Engage the platform safety prop.
4. Lower the platform on to the safety prop and continue to engage lift down for 1 second after the platform makes contact with the safety prop.
5. Disconnect power at the batteries.
6. Disconnect the Angle Sensor's electrical connection.
7. Remove the Angle Sensor.

6RS Angle Sensor Installation (RS)

1. Install the Angle Sensor with the mounting hardware.
2. Reconnect the Angle Sensor's electrical connector.
3. Reconnect power at the batteries.
4. Turn machine on and engage lift up from the ground panel so that the safety prop can be disengaged.
5. Lower the platform to the stowed position.
6. Recalibrate the machine's Angle Sensor.
7. Recalibrate the machine's Load Sensing System.

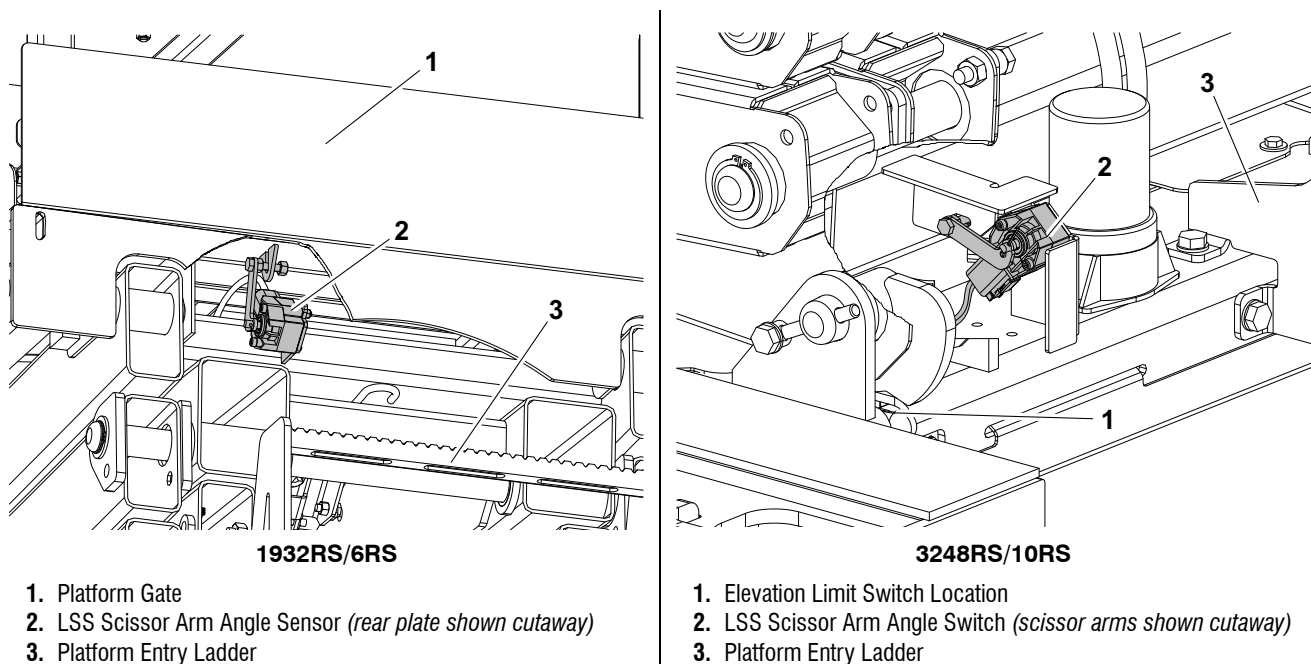

Figure 6-3. LSS - Scissor Arm Angle Sensor - (RS)

LSS Connector Pin Assignments (RS)

Table 6-4. Connections to Host Control System (J1-Black) (RS)

| PIN | SIGNAL | DESCRIPTION |
|-----|--------|--|
| 1 | PRES1 | Pressure Transducer 1 Input (0-5V) |
| 2 | PRES2 | Pressure Transducer 2 Input (0-5V) |
| 16 | PPRES | Pressure Transducers Analog Reference (0-5V) |
| 17 | NPRES | Pressure Transducers Negative Reference |

Table 6-5. Connections to Host Control System (J2-Blue) (RS)

| PIN | SIGNAL | DESCRIPTION |
|-----|--------|--|
| 5 | CANL | CANbus Low |
| 6 | CANH | CANbus High |
| 15 | CANS | CANbus Shield |
| 22 | NOVL | Negative for Overload Lamp (Low-Side Driver) |

Table 6-6. Angle Sensor Connector Pinout (RS)

| PIN | SIGNAL | DESCRIPTION |
|-----|--------|-------------------------------|
| 1 | GND | Angle Sensor Ground |
| 2 | PWR | Angle Sensor Power (10 - 30V) |
| 3 | NC | No Connect |
| 4 | NC | No Connect |
| 5 | CANH | Angle Sensor CANbus High |
| 6 | CANL | Angle Sensor CANbus Low |

Table 6-7. Pressure Transducer Connector Pinout (RS)

| PIN | SIGNAL | DESCRIPTION |
|-----|--------|--|
| A | PWR | Pressure Transducer Power (+5V) |
| B | GND | Pressure Transducer Ground |
| C | SIG | Pressure Transducer Analog Output (0 - 5V) |

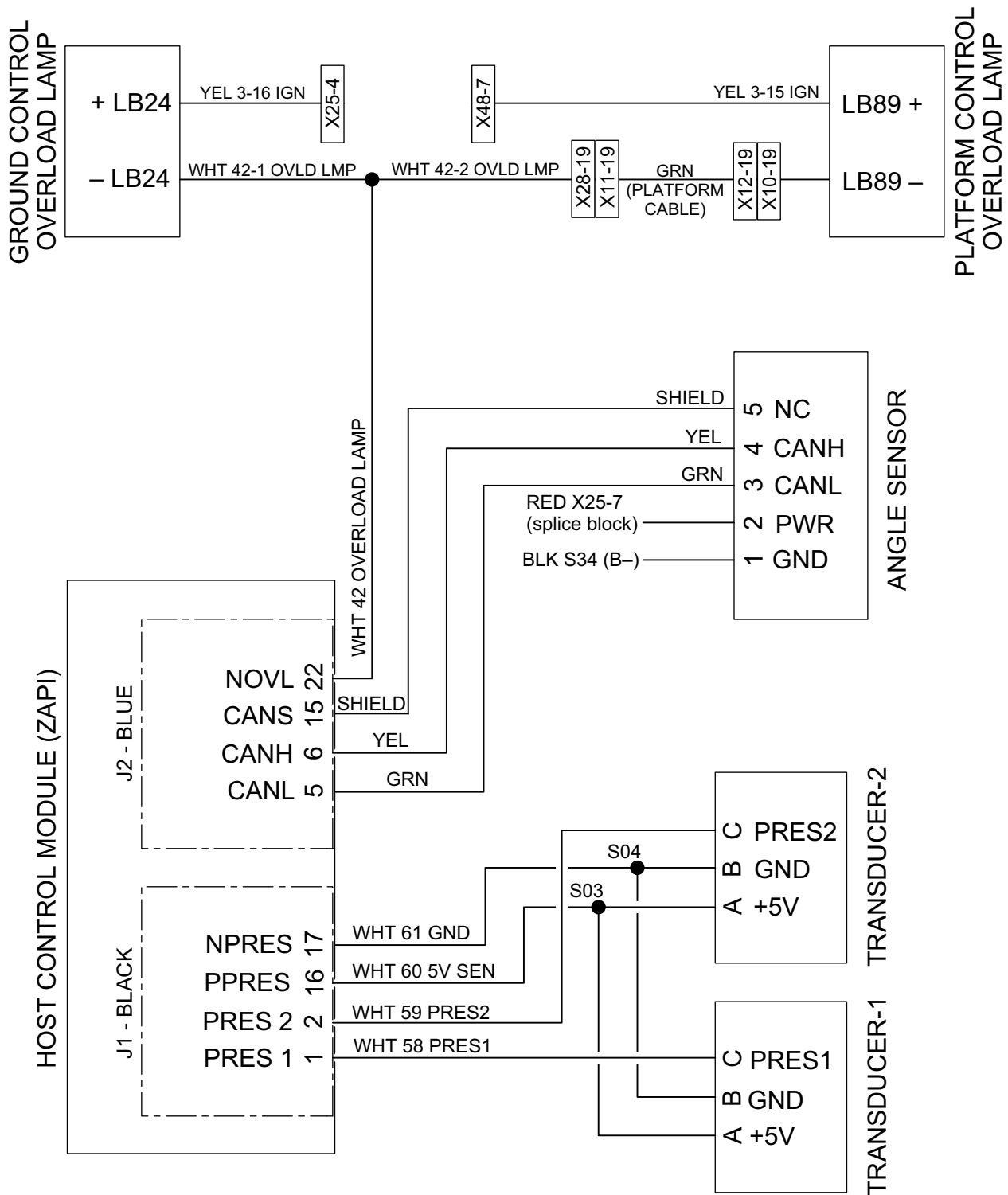

Figure 6-4. LSS - Electrical Component Schematic - (RS)

SECTION 7. PARTS

| TABLE OF CONTENTS | | |
|-------------------|--|------|
| FIGURE | DESCRIPTION | PAGE |
| 7-1 | LOAD SENSING SYSTEM INSTALLATION (260MRT, M3369/M4069 & 3369LE/4069LE) | 7-2 |
| 7-2 | LOAD SENSING SYSTEM INSTALLATION (500RTS) | 7-6 |
| 7-3 | LOAD SENSING SYSTEM INSTALLATION (1930ES/2030ES/2630ES/2646ES/3246ES) | 7-8 |
| 7-4 | LOAD SENSING SYSTEM INSTALLATION (6RS/10RS/1932RS/3248RS) | 7-12 |
| 7-5 | LOAD SENSING SYSTEM INSTALLATION (34694RT/4394RT) | 7-14 |

FIGURE 7-1. LOAD SENSING SYSTEM INSTALLATION (260MRT, M3369/M4069 & 3369LE/4069LE)

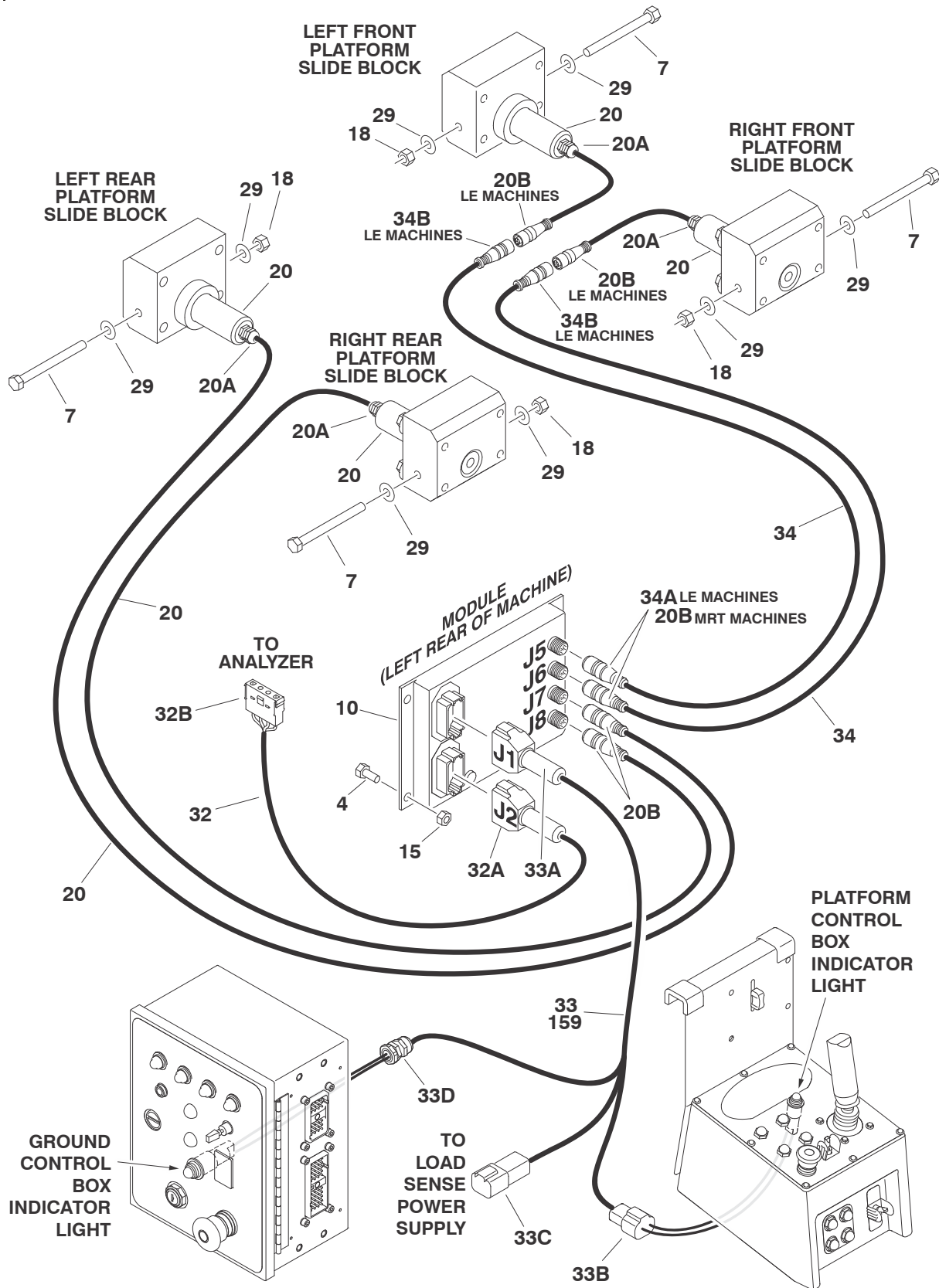

FIGURE 7-1. LOAD SENSING SYSTEM INSTALLATION (260MRT, M3369/M4069 & 3369LE/4069LE)

| FIG & ITEM # | PART NUMBER | DESCRIPTION | QTY. | REV. |
|--------------|---------------|--|------|------|
| | | LOAD SENSING SYSTEM INSTALLATION | Ref. | |
| | 0272964 | 260MRT (Platform without D-Rings) | Ref. | F |
| | 0272965 | 260MRT (Platform with D-Rings) | Ref. | E |
| | 0272930 | E/M3369/4069LE (Platform without D-Rings) | Ref. | I |
| | 0272931 | E/M3369/4069LE (Platform with D-Rings) | Ref. | I |
| 1 to 3 | Not Used | | | |
| 4 | | Bolt Options: | 3 | |
| | 0641405 | Prior to S/N 0200120066 | | |
| | 0641415 | S/N 0200120066 to Present | | |
| 5 to 6 | Not Used | | | |
| 7 | | Bolt Options: | 4 | |
| | | 260MRT: | | |
| | 0641636 | Bolt 3/8"-16NC x 4 1/2" (Prior to S/N 0200124148) | | |
| | 0701029 | Bolt (Metric) M10 x 120mm (S/N 0200124148 to Present) | | |
| | | E/M3369/4069LE: | | |
| | 3931648 | Capscrew 3/8"-16NC x 3" (Prior to S/N 0200124146) | | |
| | 4032022 | Capscrew (Metric) M10 x 90mm (S/N 0200124146 to Present) | | |
| 8 to 9 | Not Used | | | |
| 10 | | Module, Load Sensing Options: | 1 | |
| | 1600350 | Prior to S/N 0200120066 | | |
| | 1600387 | S/N 0200120066 to Present | | |
| 11 to 14 | Not Used | | | |
| 15 | 3311405 | Locknut 1/4"-20NC | 3 | |
| 16 to 17 | Not Used | | | |
| 18 | | Locknut Options: | 4 | |
| | 3311605 | Locknut 3/8"-16NC (Prior to S/N 0200124146) | | |
| | 3291005 | Locknut (Metric) M10 (S/N 0200124146 to Present) | | |
| 19 | Not Used | | | |
| 20 | 3422938 | Pin, Load Management (Includes Harness) | 4 | E |
| 20A | Not Available | Connector, Strain Relief | 1 | |
| 20B | Not Available | Plug, Male 6 Position | 1 | |
| | Not Available | Socket, Female | 6 | |
| 21 to 28 | Not Used | | | |
| 29 | 4751600 | Flatwasher 3/8" | 8 | |
| 30 to 31 | Not Used | | | |
| 32 | 4922904 | Module to Analyzer Harness | 1 | B |
| 32A | 4460836 | Plug, Male 12 Position | 1 | |
| | 4460465 | Socket, Female | 4 | |
| | 4460466 | Seal, Plug | 8 | |
| | 0840055 | Boot | 1 | |
| 32B | 4460761 | Connector, Female 4 Position | 1 | |
| | 4460294 | Pin, Male | 4 | |
| 33 | | Main Load Sensing Harness | 1 | |
| | 4922915 | 260MRT (Prior to S/N 0200193881) | | A |
| | 4922903 | E/M3369/4069LE (Prior to S/N 0200152398) | | B |

FIGURE 7-1. LOAD SENSING SYSTEM INSTALLATION (260MRT, M3369/M4069 & 3369LE/4069LE)

| FIG & ITEM # | PART NUMBER | DESCRIPTION | QTY. | REV. |
|--------------|---------------|--|------|------|
| 33A | 4460836 | Plug, Male 12 Position | 1 | |
| | 4460465 | Socket, Female | 4 | |
| | 4460466 | Seal, Plug | 8 | |
| | 0840055 | Boot | 1 | |
| 33B | 4460897 | Connector, Female 2 Position | 1 | |
| | 4460464 | Pin, Male | 2 | |
| 33C | 4460932 | Connector, Female 4 Position | 1 | |
| | 4460464 | Pin, Male | 4 | |
| 33D | 4460049 | Connector, Strain Relief | 1 | |
| 34 | 1061020 | Cable, Extension (E/M3369/4069LE Only) | 2 | B |
| 34A | Not Available | Plug, Male 6 Position | 1 | |
| | Not Available | Socket, Female | 6 | |
| 34B | Not Available | Connector, Female 6 Position | 1 | |
| | Not Available | Pin, Male | 6 | |
| | | SCISSOR ARMS INSTALLATIONS WITH LSS (LE ONLY) | Ref. | |
| | 1001110710 | 260MRT | Ref. | A |
| | 0275525 | 3369LE | Ref. | A |
| | 0275526 | 4069LE | Ref. | A |
| 159 | | Load Sensing Harness Options: | | |
| | 4922915 | 260MRT (S/N 0200193881 to Present) | | A |
| | 4922903 | E/M3369/4069LE (S/N 0200152398 to Present) | | B |

FIGURE 7-1. LOAD SENSING SYSTEM INSTALLATION (260MRT, M3369/M4069 & 3369LE/4069LE)

| FIG & ITEM # | PART NUMBER | DESCRIPTION | QTY. | REV. |
|--------------|-------------|-------------|------|------|
| | | | | |

FIGURE 7-2. LOAD SENSING SYSTEM INSTALLATION (500RTS)

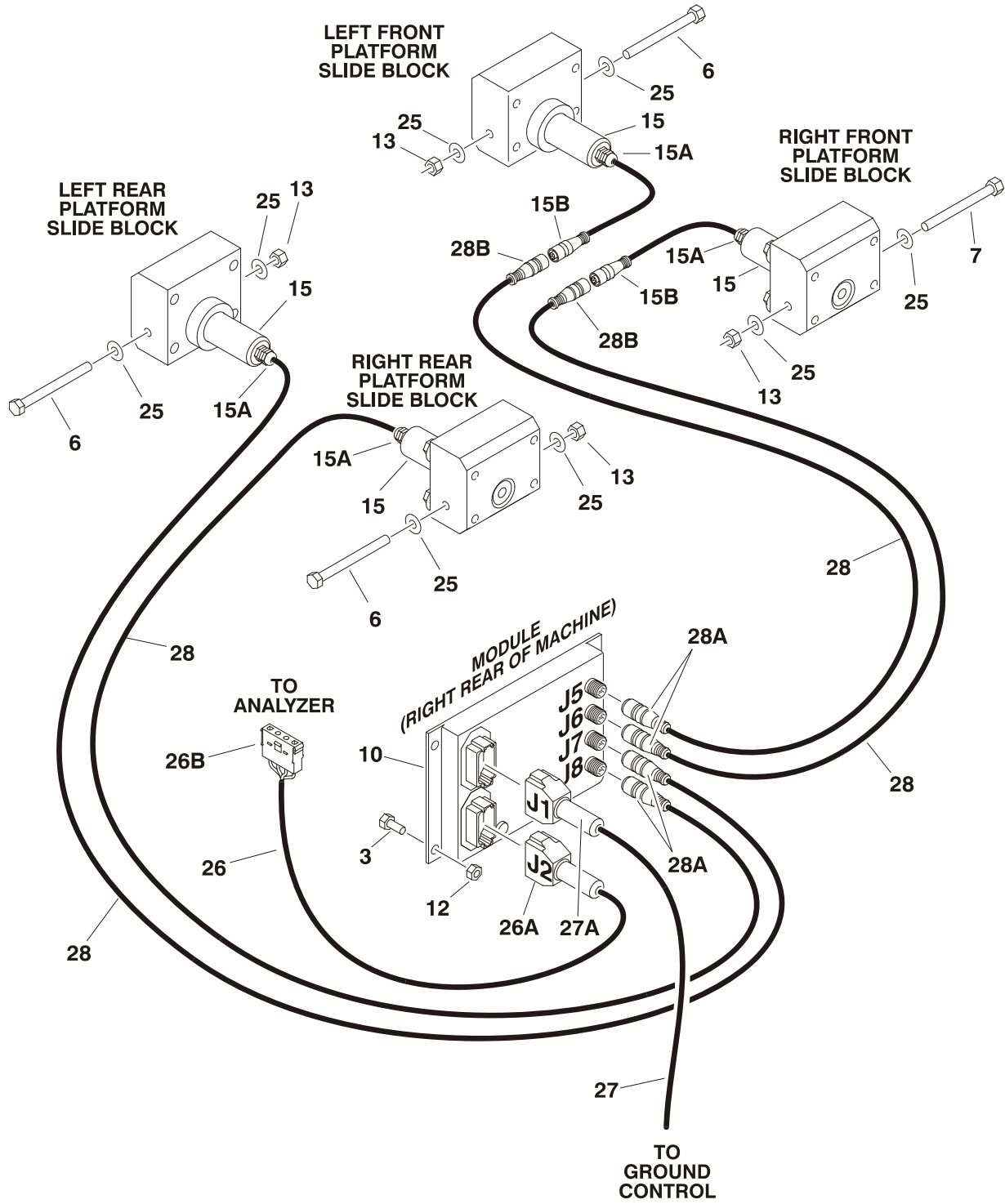

FIGURE 7-2. LOAD SENSING SYSTEM INSTALLATION (500RTS)

| FIG & ITEM # | PART NUMBER | DESCRIPTION | QTY. | REV. |
|--------------|---------------|---|------|------|
| | | LOAD SENSING SYSTEM INSTALLATION (CE SPEC) | Ref. | |
| | 0272973 | 500RTS with Standard Deck | Ref. | E |
| | 0272975 | 500RTS with Mega Deck | Ref. | E |
| 1 to 2 | Not Used | | | |
| 3 | | Bolt Options: | 3 | |
| | 0641406 | Bolt 1/4"-20NC x 3/4" (Prior to S/N 0200120099) | | |
| | 0641416 | Bolt 1/4"-20NC x 2" (S/N 0200120099 to Present) | | |
| 4 to 5 | Not Used | | | |
| 6 | 0641668 | Bolt 3/8"-16NC x 8 1/2" | 4 | |
| 7 to 9 | Not Used | | | |
| 10 | | Module, Load Sensing Options: | 1 | |
| | 1600350 | Prior to S/N 0200120099 | | |
| | 1600387 | S/N 0200120099 to Present | | |
| 11 | Not Used | | | |
| 12 | 3311405 | Locknut 1/4"-20NC | 3 | |
| 13 | 3311605 | Locknut 3/8"-16NC | 4 | |
| 14 | Not Used | | | |
| 15 | 3422939 | Pin, Load Management (Includes Harness) | 4 | D |
| 15A | Not Available | Connector, Strain Relief | 1 | |
| 15B | Not Available | Plug, Male 6 Position | 1 | |
| | Not Available | Socket, Female | 6 | |
| 16 to 19 | Not Used | | | |
| 20 | 4240033 | Tie-Strap | 4 | |
| 21 to 24 | Not Used | | | |
| 25 | 4751600 | Flatwasher 3/8" Wide | 8 | |
| 26 | 4922904 | Module to Analyzer Harness | 1 | B |
| 26A | 4460836 | Plug, Male 12 Position | 1 | |
| | 4460465 | Socket, Female | 4 | |
| | 4460466 | Seal, Plug | 8 | |
| | 0840055 | Boot | 1 | |
| 26B | 4460761 | Connector, Female 4 Position | 1 | |
| | 4460294 | Pin, Male | 4 | |
| 27 | 4922911 | Main Load Sensing Harness | 1 | B |
| 27A | 4460933 | Plug, Male 12 Position | 1 | |
| | 4460465 | Socket, Female | 4 | |
| | 4460466 | Seal, Plug | 8 | |
| | 0840055 | Boot | 1 | |
| 28 | 1061021 | Cable, Extension | 2 | B |
| 28A | Not Available | Plug, Male 6 Position | 1 | |
| | Not Available | Socket, Female | 6 | |
| 28B | Not Available | Connector, Female 6 Position | 1 | |
| | Not Available | Pin, Male | 6 | |

FIGURE 7-3. LOAD SENSING SYSTEM INSTALLATION (1930ES/2032ES/2630ES/2646ES/3246ES)

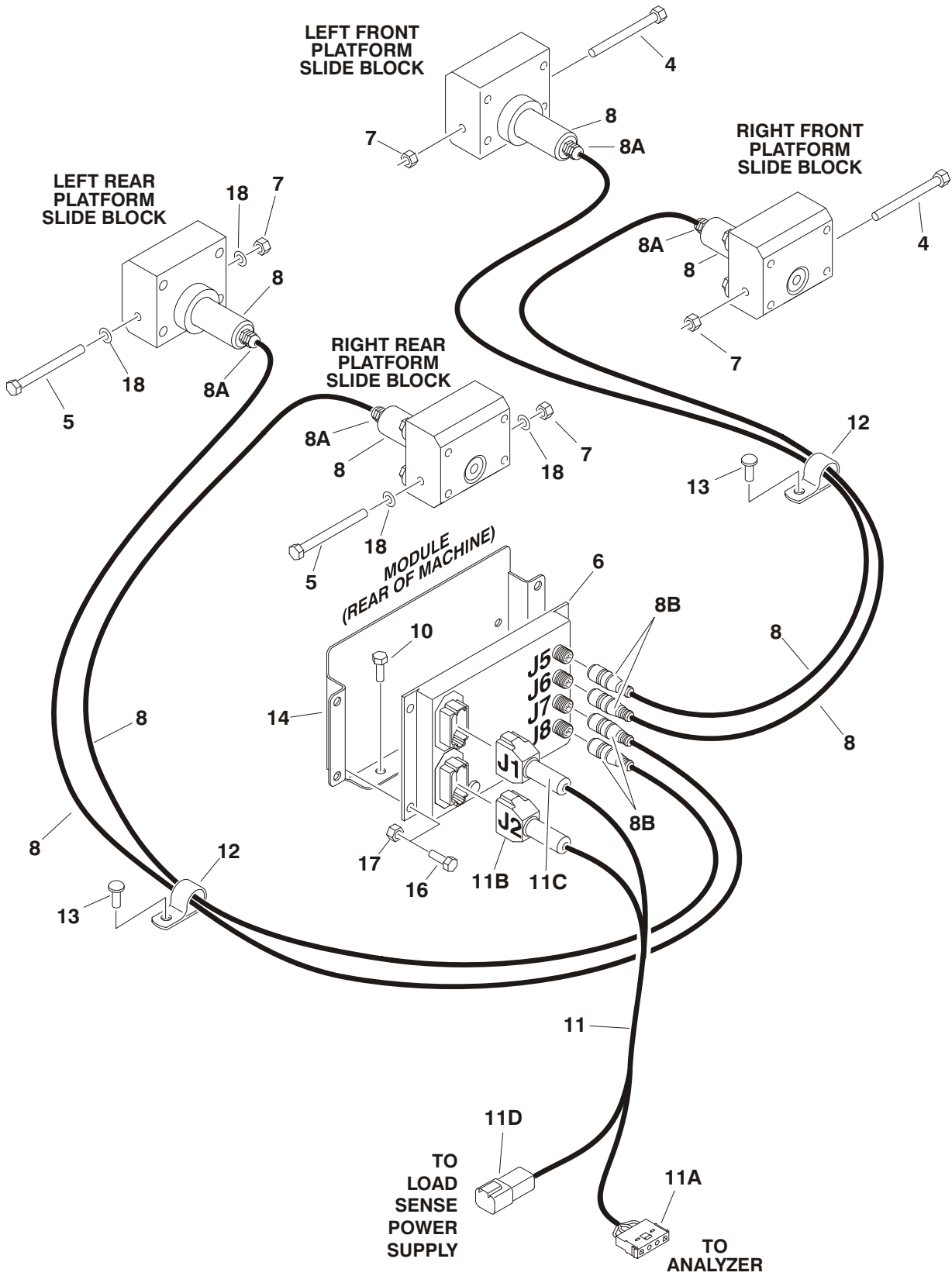

FIGURE 7-3. LOAD SENSING SYSTEM INSTALLATION (1930ES/2032ES/2630ES/ 2646ES/3246ES)

| FIG & ITEM # | PART NUMBER | DESCRIPTION | QTY. | REV. |
|--------------|---------------|--|------|------|
| | | LOAD SENSING SYSTEM INSTALLATION (CE SPEC) | Ref. | |
| | | 1930ES: | Ref. | |
| | 0272836 | USA Built Machines Prior to S/N 0200150266 & Belgium Built Machines Prior to S/N 1200007882 | Ref. | M |
| | 0275029 | USA Built Machines S/N 0200150266 to Present & Belgium Built Machines S/N 1200007882 to Present | Ref. | D |
| | | 2030ES/2630ES: | Ref. | |
| | 0272837 | USA Built Machines Prior to S/N 0200152825 & Belgium Built Machines Prior to S/N 1200008481 | Ref. | N |
| | 0274992 | USA Built Machines S/N 0200152825 to Present & Belgium Built Machines S/N 1200008481 to Present | Ref. | C |
| | | 2646ES/3246ES: | Ref. | |
| | 0272838 | USA Built Machines Prior to S/N 0200151610 & Belgium Built Machines Prior to S/N 1200008265 | Ref. | M |
| | 0274931 | USA Built Machines S/N 0200151610 to Present & Belgium Built Machines S/N 1200008265 to Present | Ref. | B |
| 1 to 3 | Not Used | | | |
| 4 | | Bolt Options: | 2 | |
| | 0701022 | Bolt M10 x 70mm (1930ES) | | |
| | 0701024 | Bolt M10 x 80mm (2030ES/2630ES/2646ES/3246ES) | | |
| 5 | | Bolt Options: | 2 | |
| | 0701026 | Bolt M10 x 90mm (1930ES) | | |
| | 0701027 | Bolt M10 x 100mm (2030ES/2630ES/2646ES/3246ES) | | |
| 6 | | Module, Load Sensing Options: | 1 | |
| | | USA Built Machines: | | |
| | 1600366 | Prior to S/N 0200120069 | | |
| | 1600387 | S/N 0200120069 to Present | | |
| | | Belgium Built Machines: | | |
| | 1600366 | Prior to S/N 1200001581 | | |
| | 1600387 | S/N 1200001581 to Present | | |
| 7 | 3291005 | Locknut M10 | 4 | |
| 8 | 3422938 | Pin, Load Management (Includes Harness) | 4 | E |
| 8A | Not Available | Connector, Strain Relief | 1 | |
| 8B | Not Available | Plug, Male 6 Position | 1 | |
| | Not Available | Socket, Female | 6 | |
| 9 | Not Used | | | |
| 10 | 4191707 | Screw M6 x 16mm | 2 | |
| 11 | | Module to Analyzer Harness Options: | 1 | |
| | | USA Built Machines: | | |
| | 4922908 | Prior to S/N 0200150266 | | D |
| | 4923228 | S/N 0200150266 to Present | | B |
| | | Belgium Built Machines: | | |
| | 4922908 | Prior to S/N 1200007882 | | D |
| | 4923228 | S/N 1200007882 to Present | | B |
| 11A | 4460761 | Connector, Female 4 Position | 1 | |
| | 4460294 | Pin, Male | 4 | |

FIGURE 7-3. LOAD SENSING SYSTEM INSTALLATION (1930ES/2032ES/2630ES/ 2646ES/3246ES)

| FIG & ITEM # | PART NUMBER | DESCRIPTION | QTY. | REV. |
|--------------|-------------------------|--|------|------|
| 11B | 4460836 | Plug, Male 12 Position | 1 | |
| | 4460465 | Socket, Female | 8 | |
| | 4460466 | Seal, Plug | 4 | |
| | 0840055 | Boot | 1 | |
| 11C | 4460836 | Plug, Male 12 Position | 1 | |
| | 4460465 | Socket, Female | 3 | |
| | 4460466 | Seal, Plug | 10 | |
| | 0840055 | Boot | 1 | |
| | 3990110 | Diode, Voltage Suppressor | 1 | |
| 11D | 4460899 | Connector, Female 6 Position | 1 | |
| | 4460464 | Pin, Male | 5 | |
| 12 | 1320318 | Clamp | 3 | |
| 13 | 1380158 | Clip | 3 | |
| 14 | | Plate, Cable Reel Options: | 1 | |
| | | USA Built Machines: | | |
| | 3680055 | Prior to S/N 0200113763 | | |
| | Use 4340931 | S/N 0200113763 to S/N 0200121287 (was p/n 3200456) | | |
| | 4340931 | S/N 0200121287 to Present | | |
| | | Belgium Built Machines: | | |
| | Prior to S/N 1200002229 | | | |
| | Use 4340931 | S/N 1200002229 to S/N 1200001914 (was p/n 3200456) | | |
| | 4340931 | S/N 1200001914 to Present | | |
| 15 | 4240033 | Tie-Strap (Not Shown) | 1 | |
| 16 | | Bolt Options: | 3 | |
| | | USA Built Machines: | | |
| | 0700608 | Bolt M6 x 16mm (Prior to S/N 0200120069) | | |
| | 0700617 | Bolt M6 x 45mm (S/N 0200120069 to Present) | | |
| | | Belgium Built Machines: | | |
| | | Bolt M6 x 16mm (Prior to S/N 1200001581) | | |
| | 0700617 | Bolt M6 x 45mm (S/N 1200001581 to Present) | | |
| 17 | 3290606 | Nut M6 | 3 | |
| 18 | 4812000 | Flatwasher 10mm | 4 | |
| 19 | 0100048 | Grease, Dielectric (Not Shown) | A/R | |

FIGURE 7-3. LOAD SENSING SYSTEM INSTALLATION (1930ES/2032ES/2630ES/ 2646ES/3246ES)

| FIG & ITEM # | PART NUMBER | DESCRIPTION | QTY. | REV. |
|--------------|-------------|-------------|------|------|
| | | | | |

FIGURE 7-4. LOAD SENSING SYSTEM INSTALLATION (6RS/10RS/1932RS/3248RS)

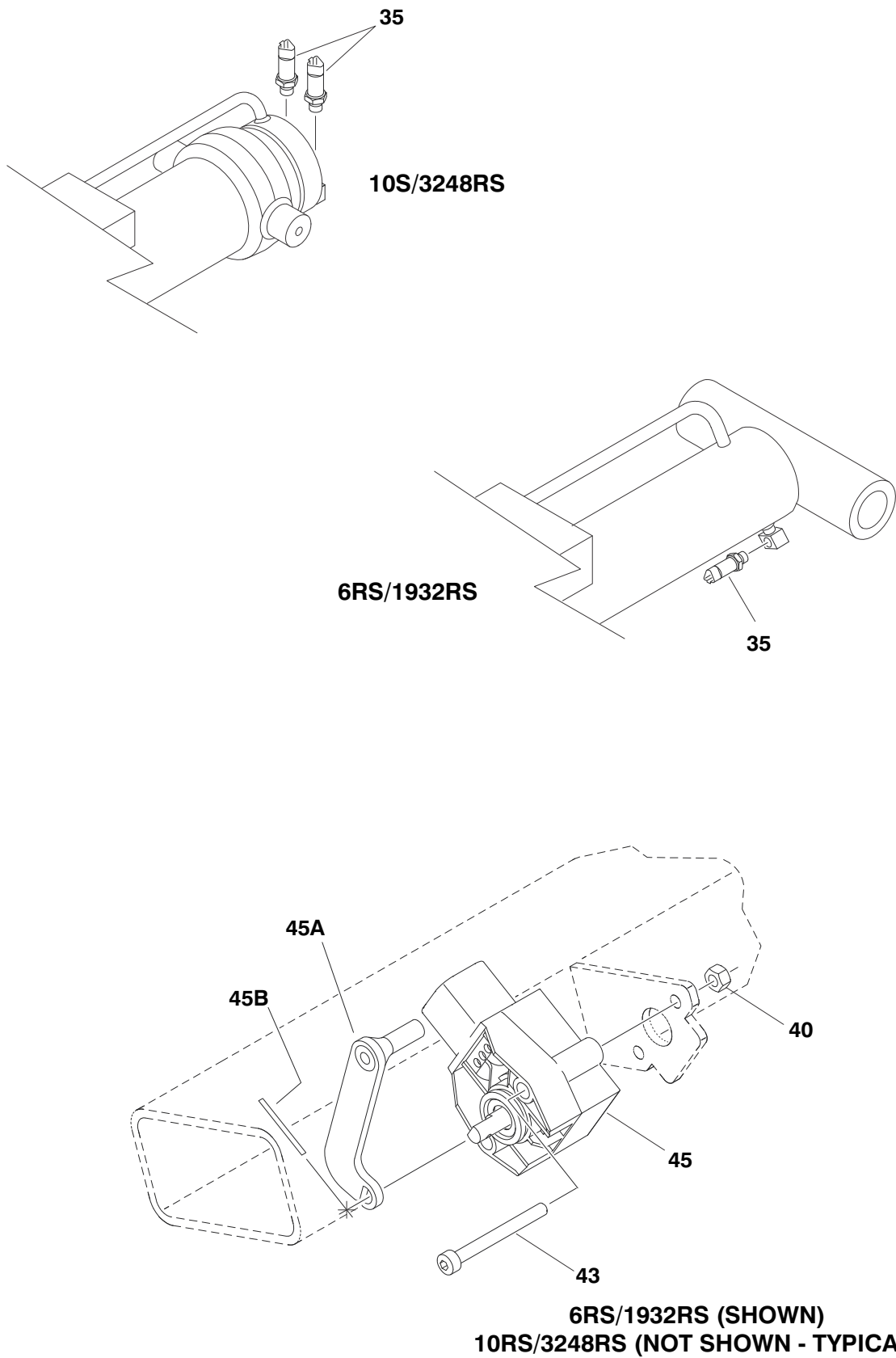

FIGURE 7-4. LOAD SENSING SYSTEM INSTALLATION (6RS/10RS/1932RS/3248RS)

| FIG & ITEM # | PART NUMBER | DESCRIPTION | QTY. | REV. |
|--------------|-------------|---|------|------|
| | | LOAD SENSING SYSTEM INSTALLATION (CE SPEC) | Ref. | |
| | 1001147250 | 6RS/1932RS | Ref. | C |
| | 1001147251 | 10RS/3248RS | Ref. | C |
| 1 to 5 | Not Used | | | |
| 6 | 3290607 | Locknut M6 | 1 | |
| 7 to 34 | Not Used | | | |
| 35 | 1001147340 | Sensor, Pressure Transducer | 2 | |
| | See Note | Harness (Note: Refer to Model Specific Parts Manual) | 1 | |
| 36 to 39 | Not Used | | | |
| 40 | 3290405 | Locknut M4 | 2 | |
| 41 to 42 | Not Used | | | |
| 43 | 4031512 | Capscrew m4 x 40mm | 2 | |
| 44 | Not Used | | | |
| 45 | 1001151800 | Sensor, Angle | 1 | |
| | 70004167 | Arm | 1 | |
| | 70004168 | Pin, Dowel | 1 | |
| | See Note | Harness (Note: Refer to Model Specific Parts Manual) | 1 | |

FIGURE 7-5. LOAD SENSING SYSTEM INSTALLATION (3394RT/4394RT)

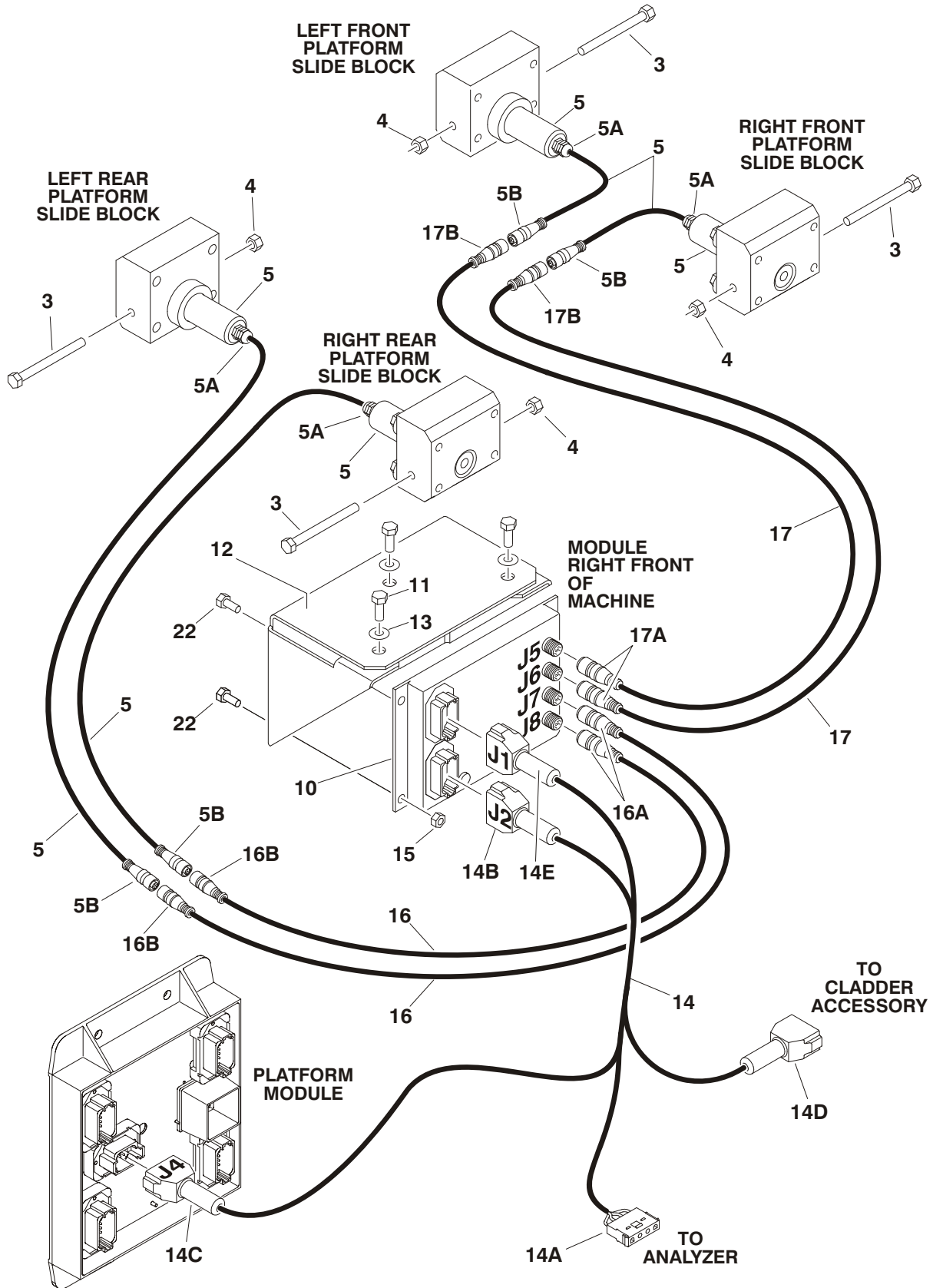

FIGURE 7-5. LOAD SENSING SYSTEM INSTALLATION (3394RT/4394RT)

| FIG & ITEM # | PART NUMBER | DESCRIPTION | QTY. | REV. |
|--------------|---------------|---|------|------|
| | | LOAD SENSING SYSTEM INSTALLATION (CE SPEC) | Ref. | |
| | 0271683 | 3394RT/4394RT | Ref. | G |
| 1 to 2 | Not Used | | | |
| 3 | | Bolt Options: | 4 | |
| | 0641660 | Bolt 3/8"-16NC x 7 1/2" (Prior to S/N 0200124146) | | |
| | 0701037 | Bolt (Metric) M10 x 200mm (S/N 0200124146 to Present) | | |
| 4 | | Locknut Options: | 4 | |
| | 3311605 | Locknut 3/8"-16NC (Prior to S/N 0200124146) | | |
| | 3311605 | Locknut (Metric) M10 (S/N 0200124146 to Present) | | |
| 5 | 3422938 | Pin, Load Management (Includes Harness) | 4 | E |
| 5A | Not Available | Connector, Strain Relief | 1 | |
| 5B | Not Available | Plug, Male 6 Position | 1 | |
| 6 to 8 | Not Used | | | |
| 9 | 0100011 | Loctite #242 (Not Shown) | A/R | |
| 10 | | Module, Load Sensing | 1 | |
| | 1600350 | Prior to S/N 0200119881 | | |
| | 1600387 | S/N 0200119881 to Present | | |
| 11 | 0641405 | Bolt 1/4"-20NC x 5/8" | 3 | |
| 12 | 0902837 | Bracket, Module Mounting | 1 | |
| 13 | 4751400 | Flatwasher 1/4" | 3 | |
| 14 | 4922882 | Module to Analyzer Harness | 1 | C |
| 14A | 4460761 | Connector, Female 4 Position | 1 | |
| | 4460294 | Pin, Male | 4 | |
| 14B | 4460836 | Plug, Male 12 Position | 1 | |
| | 4460465 | Socket, Female | 8 | |
| | 4460466 | Seal, Plug | 4 | |
| | 0840055 | Boot | 1 | |
| 14C | 4460930 | Plug, Male 8 Position | 1 | |
| | 4460465 | Socket, Female | 5 | |
| | 4460466 | Seal, Plug | 3 | |
| | 0840058 | Boot | 1 | |
| 14D | 4460931 | Connector, Female 8 Position | 1 | |
| | 4460464 | Pin, Male | 5 | |
| | 4460466 | Seal, Plug | 3 | |
| | 0840058 | Boot | 1 | |
| 14E | 4460933 | Plug, Male 12 Position | 1 | |
| | 4460465 | Socket, Female | 2 | |
| | 4460466 | Seal, Plug | 10 | |
| | 0840055 | Boot | 1 | |
| 15 | 3311405 | Locknut 1/4"-20NC | 3 | |
| 16 | 1061020 | Cable, Extension (1 Meter) | 2 | B |
| 16A | Not Available | Plug, Male 6 Position | 1 | |
| | Not Available | Socket, Female | 6 | |
| 16B | Not Available | Connector, Female 6 Position | 1 | |
| | Not Available | Pin, Male | 6 | |
| 17 | 1061021 | Cable, Extension (3 Meter) | 2 | B |
| 17A | Not Available | Plug, Male 6 Position | 1 | |
| | Not Available | Socket, Female | 6 | |

FIGURE 7-5. LOAD SENSING SYSTEM INSTALLATION (3394RT/4394RT) (CONTINUED)

| FIG & ITEM # | PART NUMBER | DESCRIPTION | QTY. | REV. |
|--------------|---------------|---|------|------|
| 17B | Not Available | Connector, Female 6 Position | 1 | |
| | Not Available | Pin, Male | 6 | |
| 18 to 19 | Not Used | | | |
| 20 | 4240033 | Tie-Strap (Not Shown) | A/R | |
| 21 | Not Used | | | |
| 22 | | Bolt Options: | 3 | |
| | 0641405 | Bolt 1/4"-20NC x 5/8" (Prior to S/N 0200119881) | | |
| | 0641415 | Bolt 1/4"-20NC x 1 7/8" (S/N 0200119881 to Present) | | |



3124288



An Oshkosh Corporation Company

Corporate Office
JLG Industries, Inc.
1 JLG Drive
McConnellsburg PA. 17233-9533
USA

☎ (717) 485-5161

📠 (717) 485-6417

JLG Worldwide Locations

JLG Industries (Australia)
P.O. Box 5119
11 Bolwarra Road
Port Macquarie
N.S.W. 2444
Australia

☎ +61 2 65 811111

📠 +61 2 65 813058

JLG Latino Americana Ltda.
Rua Eng. Carlos Stevenson,
80-Suite 71
13092-310 Campinas-SP
Brazil

☎ +55 19 3295 0407

📠 +55 19 3295 1025

JLG Industries (UK) Ltd
Bentley House
Bentley Avenue
Middleton
Greater Manchester
M24 2GP - England

☎ +44 (0)161 654 1000

📠 +44 (0)161 654 1001

JLG France SAS
Z.I. de Baulieu
47400 Fauillet
France

☎ +33 (0)5 53 88 31 70

📠 +33 (0)5 53 88 31 79

JLG Deutschland GmbH
Max-Planck-Str. 21
D - 27721 Ritterhude - Ihlpohl
Germany

☎ +49 (0)421 69 350 20

📠 +49 (0)421 69 350 45

JLG Equipment Services Ltd.
Rm 1107 Landmark North
39 Lung Sum Avenue
Sheung Shui N. T.
Hong Kong

☎ (852) 2639 5783

📠 (852) 2639 5797

JLG Industries (Italia) s.r.l.
Via Po. 22
20010 Pregnana Milanese - MI
Italy

☎ +39 029 359 5210

📠 +39 029 359 5845

Oshkosh-JLG Singapore
Technology Equipment Pte
Ltd
29 Tuas Ave 4,
Jurong Industrial Estate
Singapore, 639379

☎ +65-6591 9030

📠 +65-6591 9031

Plataformas Elevadoras
JLG Iberica, S.L.
Trapadella, 2
P.I. Castellbisbal Sur
08755 Castellbisbal, Barcelona
Spain

☎ +34 93 772 4700

📠 +34 93 771 1762

JLG Sverige AB
Enkopingsvagen 150
Box 704
SE - 176 27 Jarfalla
Sweden

☎ +46 (0)850 659 500

📠 +46 (0)850 659 534