



Illustrated Parts Manual

Models 15BD & 19BD

P/N
3121155

October 5, 2018 - Rev AA

ANSI



An Oshkosh Corporation Company

REVISION LOG

March 15, 2002 - A - Original Issue Of Manual (Edited to B/M 0010586 Revision 1)
January 15, 2009 - B - Revised Manual (Edited 0010586 to Revision 5)
February 1, 2011 - C - Revised Manual (Edited 0010586 to Revision 7)
May 20, 2011 - D - Revised Manual (Edited 0010586 to Revision 7)
August 15, 2011 - E - Revised Manual (Edited 0010586 to Revision 8)
November 14, 2011 - F - Revised Manual (Edited 0010586 to Revision 8)
February 27, 2012 - G - Revised Manual (Edited 0010586 to Revision 8)
July 3, 2012 - H - Revised Manual (Edited 0010586 to Revision B)
September 28, 2012 - I - Revised Manual (Edited 0010586 to Revision C)
February 5, 2013 - J - Revised Manual (Edited 0010586 to Revision C)
May 3, 2013 - K - Revised Manual (Edited 0010586 to Revision C)
August 2, 2013 - L - Revised Manual (Edited 0010586 to Revision C)
November 1, 2013 - M - Revised Manual (Edited 0010586 to Revision C)
September 29, 2014 - N - Revised Manual (Edited 0010586 to Revision D)
February 20, 2015 - O - Revised Manual (Edited 0010586 to Revision D)
June 22, 2015 - P - Revised Manual (Edited 0010586 to Revision D)
September 1, 2015 - Q - Revised Manual (Edited 0010586 to Revision D)
December 7, 2015 - R - Revised Manual (Edited 0010586 to Revision D)
March 7, 2016 - S - Revised Manual (Edited 0010586 to Revision D)
June 6, 2016 - T - Revised Manual (Edited 0010586 to Revision D)
September 7, 2016 - U - Revised Manual (Edited 0010586 to Revision D)
December 20, 2016 - V - Revised Manual (Edited 0010586 to Revision D)
March 28, 2017 - W - Revised Manual (Edited 0010586 to Revision D)
June 21, 2017 - X - Revised Manual (Edited 0010586 to Revision E and 1001207301 Revision A)
December 21, 2017 - Y - Revised Manual (Edited 0010586 to Revision E and 1001207301 Revision A)
March 23, 2018 - Z - Revised Manual (Edited 0010586 to Revision E and 1001207301 Revision A)
October 5, 2018 - AA - Revised Manual (Edited 0010586 to Revision E and 1001207301 Revision B)

GENERAL INFORMATION

SECTION 6 CYLINDER

FIGURE 6-3. LIFT CYLINDER ASSEMBLY

PG# Model Designation Manual #

SECTION 6 CYLINDER

FIGURE 6-3. LIFT CYLINDER ASSEMBLY

ITEM #	PART NUMBER	QTY.	DESCRIPTION	REV.
	1001140104	Ref	LIFT CYLINDER ASSEMBLY	B
1	0100011	AR	Compound, Locking	
2	0630535	3	Capscrew 1/4-20 x 1-1/8	
3	0791003	1	Screw #10-24 x 3/8	
4	0961897	1	Bushing, Tapered	
5	1320136	1	Clamp, Cable	
6	1683063	1	Head	
7	2220883	1	Plug, O-Ring	
8	2220885	2	Plug, O-Ring	
9	2220886	1	Plug, O-Ring	
10	3020039	AR	Lubricant	
11	3480282	1	Piston	
12	3760371	1	Ring, Washer	
13	3931420	8	Capscrew 1/4-20 x 1-1/4	
14	3931824	8	Capscrew 1/2-13 x 1-1/2	
15	3951003	1	Set screw #10-24 x 3/8	
16	4100099	1	Spacer	
17	4640999	1	Cartridge, Holding Valve (Non Vented)	
17	2900792		Kit, Seal - 4640999 Cartridge Valve	
18	4641248	1	Cartridge, Counterbalance Valve (Non Vented)	
18	70004186		Kit, Seal - 4641248 Cartridge Valve	
19	1001117991	1	Sensor, Cylinder Length	
20	1001118070	1	Cap, Retainer	
21	1001118084	1	Barrel	
21A	0961950	2	Bushing	
22	1001118086	1	Rod	
22A	0961950	2	Bushing	
100	1001139996	1	Kit, Seal (Includes Items 101-109)	
101	See Note	2	Ring, Wear (Note: Use p/n 1001139996)	
102	See Note	1	Ring, Back-Up (Note: Use p/n 1001139996)	
103	See Note	2	Ring, Lock (Note: Use p/n 1001139996)	
104	See Note	2	Ring, Back-Up (Note: Use p/n 1001139996)	
105	See Note	2	O-Ring (Note: Use p/n 1001139996)	
106	See Note	1	O-Ring (Note: Use p/n 1001139996)	
107	See Note	1	Seal (Note: Use p/n 1001139996)	
108	See Note	1	Wiper, Rod (Note: Use p/n 1001139996)	
109	See Note	2	Seal (Note: Use p/n 1001139996)	
200	1001119105	1	Kit, Sensor Magnet (Includes Items 201-203)	
201	See Note	NSS	Sleeve, Spacer (Note: Use p/n 1001119105)	
202	1001118066	1	Magnet, Sensor	
203	1001118069	1	Ring, Internal Retaining	

Manual # Model Designation PG#

1) MACHINE IDENTIFICATION

Machines are identified by model and in some cases a combination of models, serial number (SN) or regional standard (i.e. ANSI, CE, CSA). Components may also be identified by SN or manufacturer. Common components that may be identified by these characteristics are engines and hydraulic components.

2) PARTS MANUAL ORGANIZATION

Product information in this manual is organized under section titles. Frame, Cylinder, Hydraulic and Electrical are a few examples. Each section is organized by figure and page number. The information within the Figure is then organized by item number, part number, description and corresponding illustration(s).

3) TABLE OF CONTENTS

A table of contents is found toward the beginning of the manual. Figure number, description and page number are provided for quick reference to the page containing the related information.

4) RECOMMENDED SPARE PARTS

The Recommended Spare Parts, located near the end of the manual, reference most frequently used maintenance parts.

5) PART NUMBER INDEX

A numerical index listing all part numbers and the corresponding page number(s) appears at the back of the manual.

GENERAL INFORMATION

6) NON-SERVICED PARTS

In some instances, it is necessary to display non-serviced parts, assemblies or installations. In the case of assemblies and installations there will be a Ref in the Qty column. In case of parts that are not available for service within assemblies or components, there will be a NSS (Not Sold Separately) or NLA (No Longer Available) listed in the Qty. column of the manual.

7) PARTS LIST ITEM NUMBERS

Numbers shown in the item# column correspond to numbers used in the associated illustration (s). Item numbers which are missing from the sequence in the parts list are not used on that page

8) INDENTED PARTS DESCRIPTION

An indented part description is included in the item under which it is indented.

9) ABBREVIATION AND SYMBOLS

AC.....	.. Alternating Current	LCD.....	.. Liquid Crystal Display
ADE.....	.. Advanced Design Electronics	LED.....	.. Light Emitting Diodes
ANSI.....	.. American National Standards Institute	LH.....	.. Left Hand
AR.....	.. As Required	LSS.....	.. Load Sensing System
ASSY.....	.. Assembly	M(m).....	.. Metric/Meter
AUX.....	.. Auxiliary	MM (mm).....	.. Milimeter
AWG.....	.. American Wire Gauge	mA.....	.. Milliamps
B/M.....	.. Bill of Material	NLA.....	.. No Longer Available
CE.....	.. European Conformity	NPT.....	.. National Pipe Threads
CCW.....	.. Counter Clockwise	NSS.....	.. Not Sold Separately
cm.....	.. Centimeter	OD.....	.. Outside Diameter
CW.....	.. Clockwise	ORB.....	.. O-Ring Boss
CSA.....	.. Canadian Standards Association	ORFS.....	.. O-Ring Face Seal
CYL.....	.. Cylinder	OZ (oz).....	.. Ounces
DIA.....	.. Diameter	PG.....	.. Page
DC.....	.. Direct Current	P/N.....	.. Part Number
EMS.....	.. Emergency Stop	qt.....	.. Quarts
ENG.....	.. Engine	QTY.....	.. Quantity
FT (ft).....	.. Feet	REF.....	.. Reference
GA (Ga).....	.. Gauge	REV.....	.. Revision Level
HYD.....	.. Hydraulic	RH.....	.. Right Hand
Hz.....	.. Hertz	SAE.....	.. Society of Automotive Engineers
ID.....	.. Inside Diameter	SN.....	.. Serial Number
in.....	.. inches	SPEC(S).....	.. Specifications
ISO.....	.. International Organization for Standards	T/T.....	.. Turntable
JIC.....	.. Joint Industry Council	UGM.....	.. Universal Ground Module
KG.....	.. Kilogram	V.....	.. Volts
L.....	.. Liter	W.....	.. Watts
LB.....	.. Pounds	#.....	.. Number

10) ILLUSTRATION REFERENCE LETTERS

When necessary, illustrations may contain reference letters that are intended to track information (i. e. hoses, harnesses) from one point to another or to track visual enlargement of components to show details that may be located in another area on the illustration.

Note: Due to continuous product improvements, JLG Industries, Inc. reserves the right to make specification changes without prior notification. Contact JLG Industries, Inc. for updated information.

TABLE OF CONTENTS

SECTION 1 - BASE.....	9
FIGURE 1-1. BASE COMPONENTS AND MAST INSTALLATION.....	10
SECTION 2 - CONTROLS.....	13
FIGURE 2-1. POWER COMPONENTS INSTALLATION.....	14
FIGURE 2-2. MOTOR/PUMP ASSEMBLY (ALL MACHINES) (Excluding SN 0130005748).....	18
FIGURE 2-3. MOTOR/PUMP ASSEMBLY (Including SN 0130005748).....	20
FIGURE 2-4. AC JUNCTION BOX ASSEMBLY.....	22
FIGURE 2-5. CABLES AND CONTROLS INSTALLATION (15BD WITH PUSH BUTTON CONTROLS).....	26
FIGURE 2-6. CABLES AND CONTROLS INSTALLATION (15BD WITH FOOT CONTROLS).....	30
FIGURE 2-7. CABLES AND CONTROLS INSTALLATION (19BD WITH FOOT CONTROLS).....	34
SECTION 3 - MAST.....	37
FIGURE 3-1. MAST ASSEMBLY (15BD).....	38
FIGURE 3-2. MAST ASSEMBLY (19BD).....	42
SECTION 4 - PLATFORM.....	47
FIGURE 4-1. PLATFORM WITH GULLWING GATE (15BD ONLY).....	48
FIGURE 4-2. PLATFORM (27IN/69CM X 23IN/58.5CM) WITH SWING GATE.....	50
FIGURE 4-3. PLATFORM (26IN/66CM X 25IN/63.5CM) WITH SWING GATE.....	52
FIGURE 4-4. PLATFORM OPTIONS.....	54
FIGURE 4-5. PLATFORM GATE INTERLOCK INSTALLATION.....	56
SECTION 5 - CYLINDER.....	59
FIGURE 5-1. LIFT CYLINDER ASSEMBLY (ALL MACHINES) (Excluding SN 0130005748).....	60
FIGURE 5-2. LIFT CYLINDER ASSEMBLY (Including SN 0130005748).....	62
SECTION 6 - HYDRAULIC.....	65
FIGURE 6-1. HYDRAULIC DIAGRAM.....	66
SECTION 7 - ELECTRICAL.....	69
FIGURE 7-1. ELECTRICAL SCHEMATIC - 120VAC, 60HZ.....	70
FIGURE 7-2. ELECTRICAL SCHEMATIC - 120VAC, 60HZ (CORNING SPEC).....	72
FIGURE 7-3. ELECTRICAL SCHEMATIC - 120VAC, 50-60HZ (CORNING SPEC).....	74
FIGURE 7-4. ELECTRICAL SCHEMATIC - 220VAC, 50-60HZ (CORNING SPEC).....	76
SECTION 8 - DECALS.....	79
FIGURE 8-1. DECAL INSTALLATION.....	80
SECTION 9 - RECOMMENDED SERVICE PARTS STOCK.....	83
FIGURE 9-1. 15BD STANDARD PARTS.....	84
FIGURE 9-2. 15BD VARIABLE PARTS.....	86
SECTION 10 - SPECIAL OPTIONS.....	87
FIGURE 10-1. SPECIAL OPTIONS.....	88
PART NUMBER INDEX.....	89

SECTION 1 - BASE

SECTION 1 - BASE

FIGURE 1-1. BASE COMPONENTS AND MAST INSTALLATION

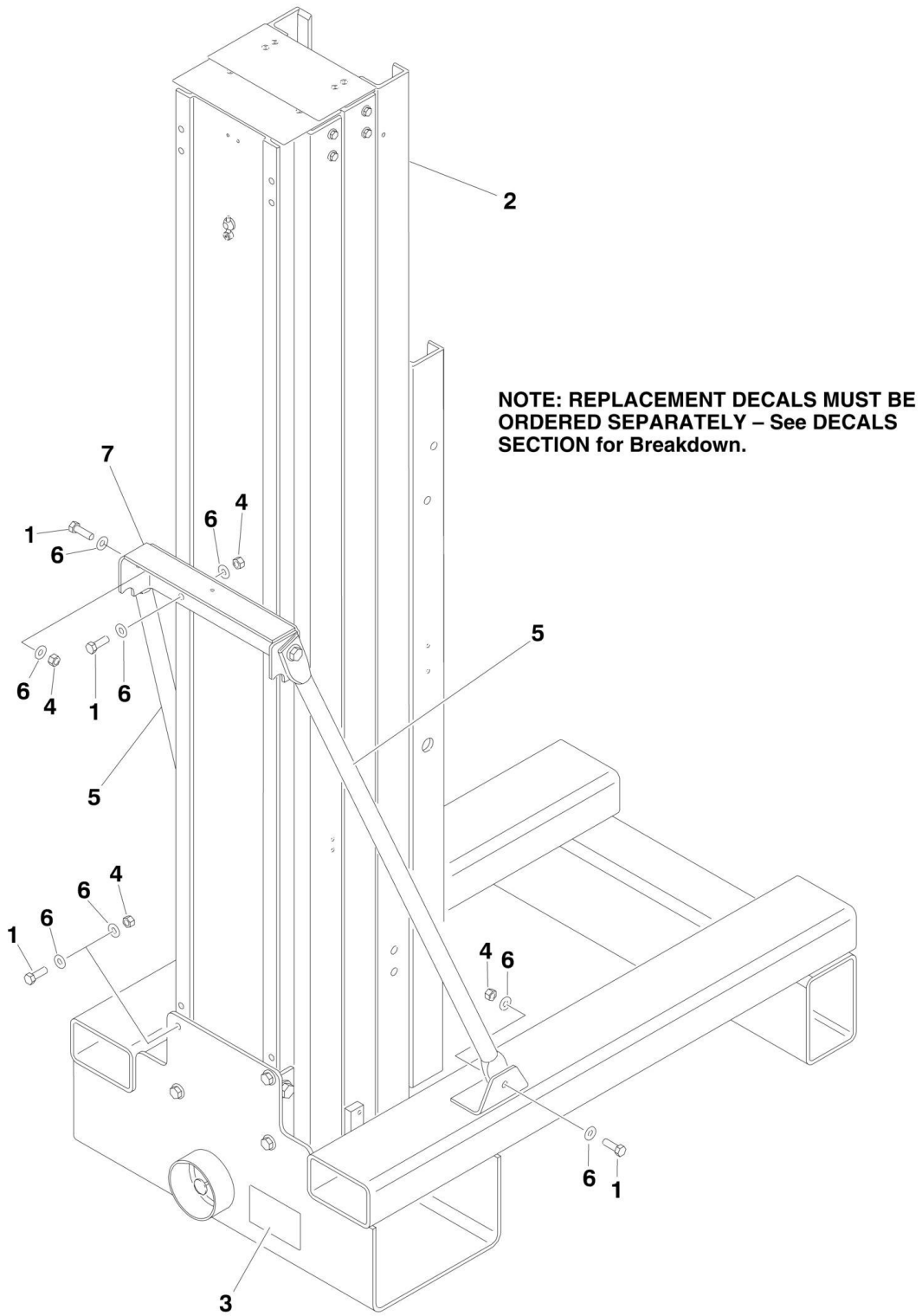

SECTION 1 - BASE

FIGURE 1-1. BASE COMPONENTS AND MAST INSTALLATION

ITEM	PART NUMBER	QTY	DESCRIPTION	REV
		Ref	MAST SUPPORT INSTALLATIONS	
	0271828	Ref	Mast Support Installations 15BD (Excluding SN 0130005748)	D
	0272127	Ref	Mast Support Installations 15BD (Including SN 0130005748)	B
	1001128982	Ref	Mast Support Installations 19BD	B
1		Ref	Bolt Options:	
1	0641609	AR	Bolt 3/8in-16NC x 1-1/8in	
1	0641610	AR	Bolt 3/8in-16NC x 1-1/4in	
2		Ref	Mast Assembly Options (See MAST SECTION for Breakdown):	
2	0801321	1	Mast Assembly 15BD (Excluding SN 0130005748)	
2	0801328	1	Mast Assembly 15BD (Including SN 0130005748)	
2	0801409	1	Mast Assembly 19BD	
3	1705636	AR	Decal - Manual Descent (Including SN 0130005748)	
4		Ref	Nut Options:	
4	3311605	AR	Locknut 3/8in-16NC	
4	3311608	AR	Flanged Nut 3/8in-16NC	
5	4568473	2	Brace Tube, Mast	
6	4711600	24	Flatwasher 3/8in Thin	
7	4845914	1	Support, Mast	
		Ref	Base Weldment	
	4846589	Ref	18 x 33 Bolt Pattern	
	1001126088	Ref	20 x 24 Bolt Pattern	

SECTION 2 - CONTROLS

SECTION 2 - CONTROLS

FIGURE 2-1. POWER COMPONENTS INSTALLATION

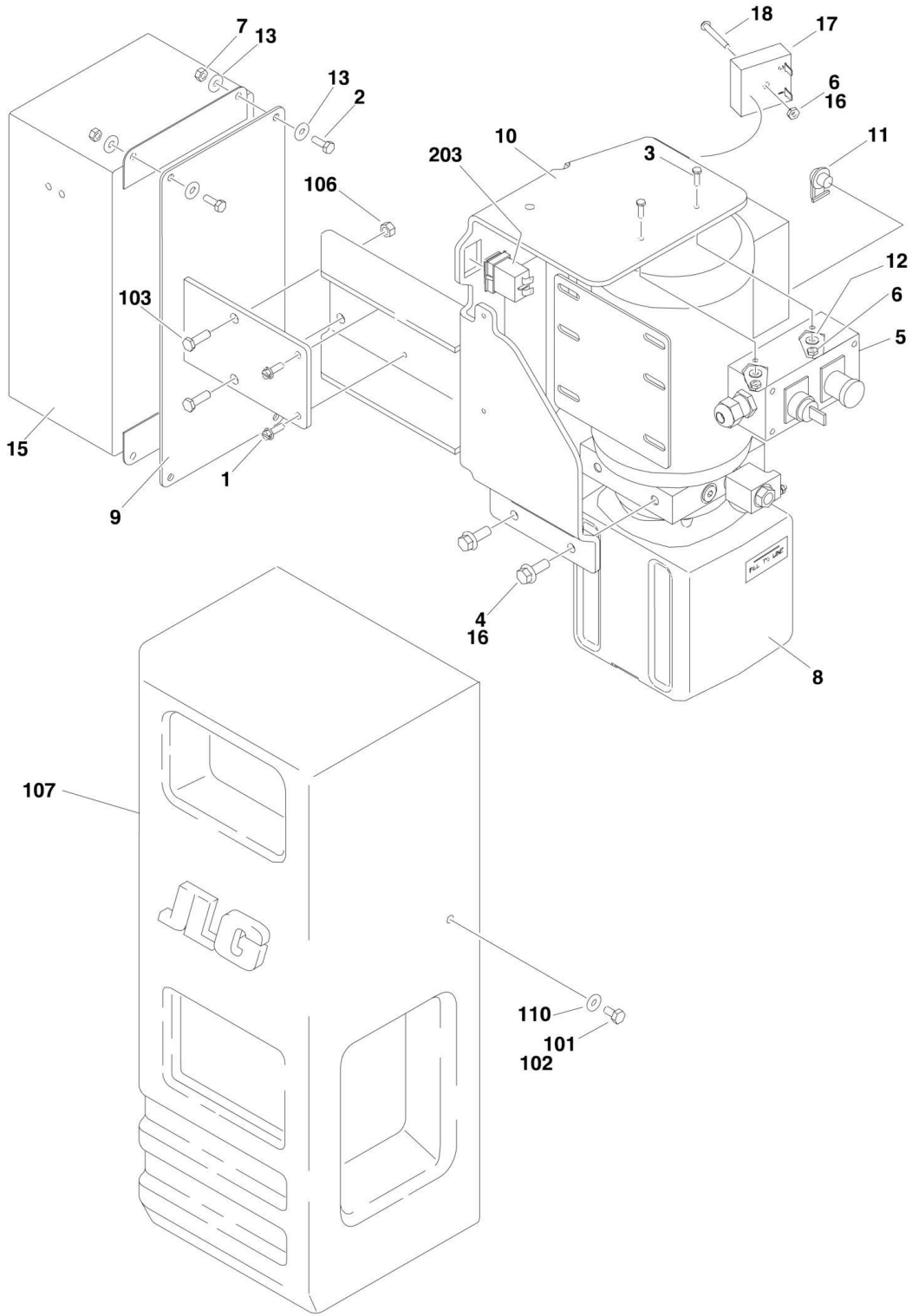

SECTION 2 - CONTROLS

FIGURE 2-1. POWER COMPONENTS INSTALLATION

ITEM	PART NUMBER	QTY	DESCRIPTION	REV
		Ref	PUMP/MOTOR AND JUNCTION BOX ASSEMBLY	
	1001111734	Ref	120 VAC, 60Hz (15BD) (All Machines) (Excluding SN 0130005748)	A
	See Note	Ref	120 VAC, 60Hz (Note: Uses Installation p/n 0271128 with Kit p/n 2915246 installed.) (15BD) (Including SN 0130005748)	
	1001167245	Ref	120VAC, 60Hz (19BD)	A
	1001147216	Ref	120 VAC, 50-60Hz (with AC Outlet)	A
	1001144708	Ref	220 VAC, 50-60Hz	A
1	0630550	2	Capscrew 1/4in-20NC x 3/4in	
2	0641406	4	Bolt 1/4in-20NC x 3/4in	
3	0721006	2	Screw #10-24NC x 3/4in	
4	0791608	2	Screw 3/8in-16NC x 3/4in	
5	0861305	1	Ground Control Box Assembly	E
5	7020078	1	Switch, Push-Pull (Stop)	
5	7020096	1	Legend Plate, "Stop"	
5	7020097	2	Legend Plate, "Power/Off/On"	
5	4360467	1	Switch, Key	
5	2860030	1	Key, Replacement	
5	7027299	1	Connector, Strain Relief	
5	7020093	1	Screw M3 x 25mm (Box Lid Hardware)	
5	3910804	2	Screw #8-32NC x 1/4in (Keypswitch Terminals)	
5	7020094	1	Lid	
6	3311005	AR	Locknut #10-24NC	
7	3311405	4	Locknut 1/4in-20NC	
8		Ref	Pump/Motor Assembly Options:	
8	3600467	1	Pump/Motor Assembly - 15BD with 120VAC, 60Hz Motor (See MOTOR/PUMP ASSEMBLY for Breakdown) (Excluding SN 0130005748)	
8	3600453	1	Pump/Motor Assembly - 15BD with 120VAC, 60Hz Motor (See MOTOR/PUMP ASSEMBLY for Breakdown) (Including SN 0130005748)	
8	3600453	1	Pump/Motor Assembly - 19BD with 120VAC, 60Hz Motor (See MOTOR/PUMP ASSEMBLY for Breakdown)	
8	3600453	1	Pump/Motor Assembly - All Machines with 120VAC, 50-60Hz Motor & AC Outlet (See MOTOR/PUMP ASSEMBLY for Breakdown)	
8	3600453	1	Pump/Motor Assembly - All Machines with 220VAC, 50-60Hz Motor (See MOTOR/PUMP ASSEMBLY for Breakdown)	
9	4341431	1	Bracket, Junction Box Mounting Options	
10	4341432	1	Bracket, Pump/Motor Mounting Options:	
11	4460566	1	Connector, 90 Strain Relief	
12	4751000	2	Flatwasher #10 Regular	
13	4751400	8	Flatwasher 1/4in Regular	
14	1001105113	2	Insulation, Heatshrink (Not Shown)	
15		Ref	Junction Box Assembly (See AC JUNCTION BOX ASSEMBLY for Breakdown)	
15	1001111733	1	120 VAC, 60Hz (All Machines) (Excluding SN 0130005748)	
15	0861476	1	120 VAC, 60Hz (Including SN 0130005748)	
15	1001147215	1	120 VAC,50- 60Hz	
15	1001144703	1	220 VAC,50- 60Hz	
16	0100011	AR	Compound, Locking	
17	3740154	1	Relay, Timer (Used on 120 VAC, 50-60Hz Only)	

SECTION 2 - CONTROLS

ITEM	PART NUMBER	QTY	DESCRIPTION	REV
18	3911024	1	Screw #10-24NC x 1-1/2in (Used on 120 VAC, 50-60Hz Only)	
		Ref	PUMP/MOTOR AND JUNCTION BOX INSTALLATION	B
	0275939	Ref	All Machines with Gullwing or Right Side Entry Platforms (Excluding SN 0130005748)	A
	1001126224	Ref	All Machines with Left Side Entry Platforms (Not Shown) (Excluding SN 0130005748)	A
		Ref	Note: Right/Left Side Gate Entry determined by operator's position when facing push button controls.	
101	0100011	AR	Compound, Locking	
102	0641404	4	Bolt 1/4in-20NC x 1/2in	
103	0791609	4	Bolt 3/8in-16NC x 1-1/8in	
106	3311608	4	Nut, Flanged 3/8in-16NC	
107	4061024	1	Shield, Pump Cover	
110	4711400	4	Flatwasher 1/4in Thin	
	0275697	Ref	HOURLY METER INSTALLATION (OPTIONAL)	C
203	2420172	1	Hourmeter	
205	4922935	1	Harness, Hourmeter (Not Shown)	A

SECTION 2 - CONTROLS

FIGURE 2-2. MOTOR/PUMP ASSEMBLY (ALL MACHINES) (Excluding SN 0130005748)

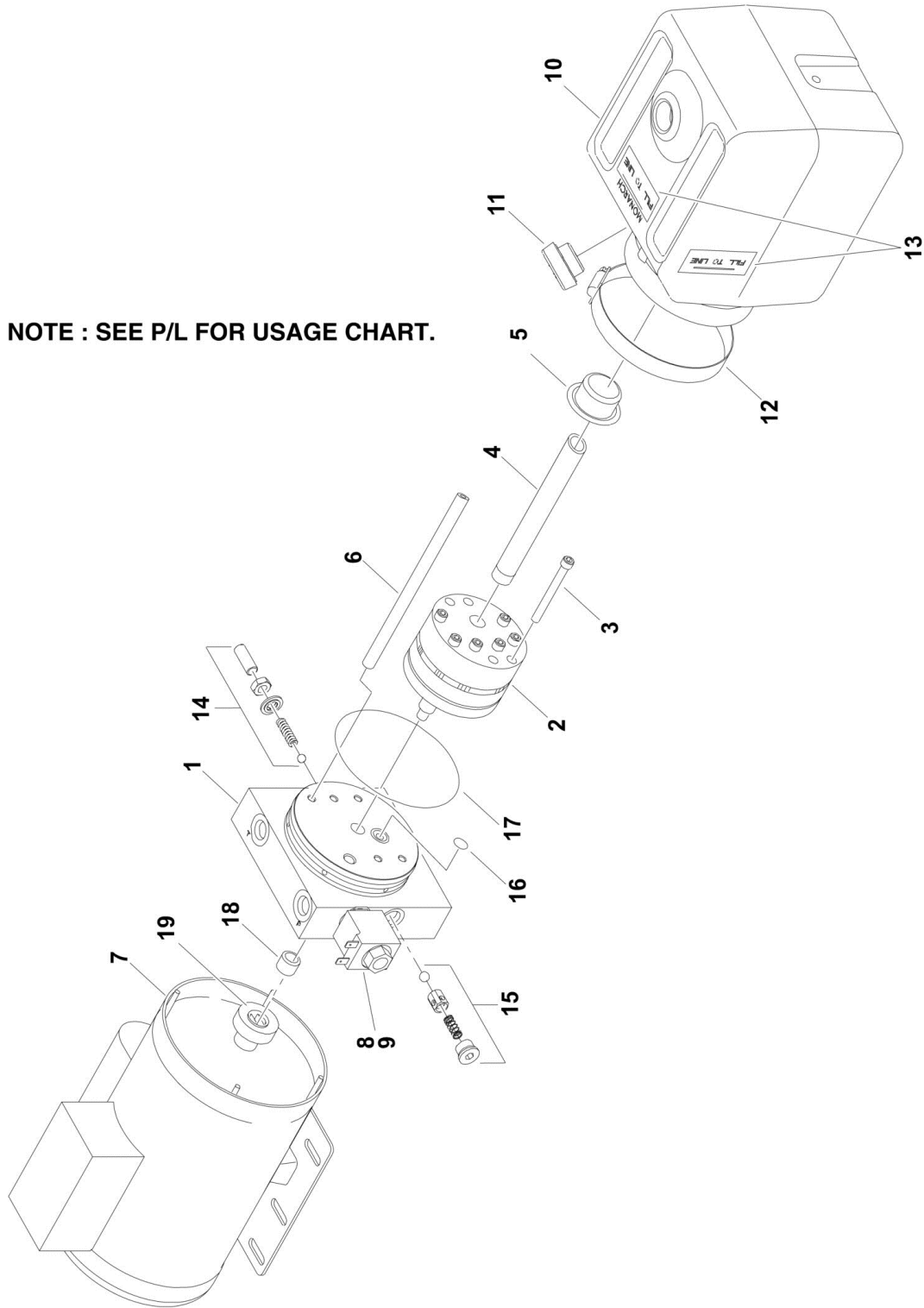

SECTION 2 - CONTROLS

FIGURE 2-2. MOTOR/PUMP ASSEMBLY (ALL MACHINES) (Excluding SN 0130005748)

ITEM	PART NUMBER	QTY	DESCRIPTION	REV
		Ref	USAGE CHART:	
	3600467	Ref	Pump/Motor Assembly - 15BD with 120VAC, 60Hz Motor without AC Outlet (Shown in This Figure) (Excluding SN 0130005748)	
	3600453	Ref	Pump/Motor Assembly - 15BD with 120VAC, 60Hz Motor (See Next Figure) (Including SN 0130005748)	
	3600453	Ref	Pump/Motor Assembly - 19BD with 120VAC, 60Hz Motor (See Next Figure)	
	3600453	Ref	Pump/Motor Assembly - All Machines with 120VAC, 50-60Hz Motor & AC Outlet (See Next Figure)	
	3600453	Ref	Pump/Motor Assembly - All Machines with 220VAC, 50-60Hz Motor (See Next Figure)	
	3600467	Ref	MOTOR/PUMP ASSEMBLY	C
1	70000641	1	Base Assembly (Includes Items 14-18)	
2	70001021	1	Pump (Includes Item 3)	
3	70001020	4	Screw 1/4in-20NC x 2-3/4in	
4	70001042	1	Tube, Suction	
5	7026165	1	Filter	
6	70001044	1	Tube, Return	
7	70001045	1	Motor (Includes Item 19 and Motor Bolts)	
8	70000642	1	Cartridge	
9	70000643	1	Coil	
10	70000651	1	Reservoir	
11	70001025	1	Plug	
12	7026335	1	Clamp	
13	70001027	1	Decal - Fill Line	
14	70000641	1	Valve, Relief (Note: Part of Item 1)	
14	70000641	1	Screw	
14	70000641	1	Nut	
14	70000641	1	Seal	
14	70000641	1	Spring	
14	70000641	1	Ball	
15	70000641	1	Valve, Check (Note: Part of Item 1)	
15	70000641	1	Plug	
15	70000641	1	Spring	
15	70000641	1	Poppet	
15	70000641	1	Ball	
16	70003612	1	O-Ring (1/2in x 5/8in x 1/16in)	
17	70003613	1	O-Ring (3-5/8in x 3-7/8in x 1/8in)	
18	7026330	1	Seal	
19	70002215	1	Bearing	

SECTION 2 - CONTROLS

FIGURE 2-3. MOTOR/PUMP ASSEMBLY (Including SN 0130005748)

NOTE : SEE P/L FOR USAGE CHART.

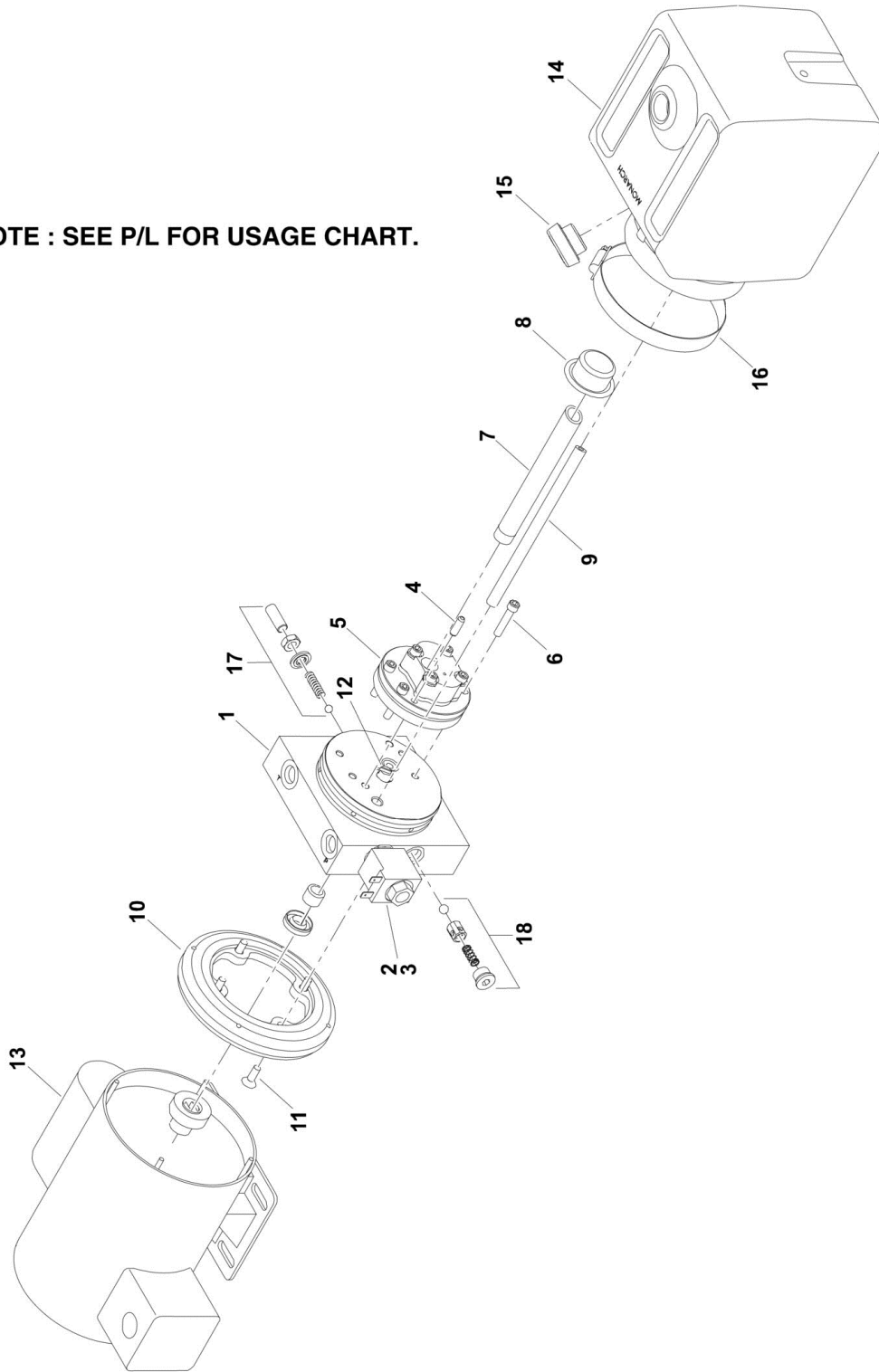

SECTION 2 - CONTROLS

FIGURE 2-3. MOTOR/PUMP ASSEMBLY (Including SN 0130005748)

ITEM	PART NUMBER	QTY	DESCRIPTION	REV
		Ref	USAGE CHART:	
	3600467	1	Pump/Motor Assembly - 15BD with 120VAC, 60Hz Motor without AC Outlet (See Previous Figure) (Excluding SN 0130005748)	
	3600453	1	Pump/Motor Assembly - 15BD with 120VAC, 60Hz Motor (Shown in This Figure)	
	3600453	1	Pump/Motor Assembly - 19BD with 120VAC, 60Hz Motor (Shown in This Figure)	
	3600453	1	Pump/Motor Assembly - All Machines with 120VAC, 50-60Hz Motor & AC Outlet (Shown in This Figure)	
	3600453	1	Pump/Motor Assembly - All Machines with 220VAC, 50-60Hz Motor (Shown in This Figure)	
	3600453	Ref	MOTOR/PUMP ASSEMBLY	B
1	70000641	1	Adapter, Motor/Pump/Tank (Includes Items 17 & 18)	
2	70000642	1	Cartridge	
3	70000643	1	Coil	
5	70000644	1	Pump	
6	3931420	4	Screw 1/4in-20NC x 1- 1/4in	
7	70000645	1	Tube, Suction	
8	7026165	1	Filter	
9	70000646	1	Tube, Return	
10	70000647	1	Plate, Motor Adapter	
11	70000648	4	Screw 1/4in-20NC x 3/4in	
12	70000649	1	Shaft, Intermediate	
13	70000650	1	Motor	
14	70000651	1	Reservoir	
15	7026160	1	Plug	
16	7026335	1	Clamp	
17	70000641	1	Valve, Relief (Note: Part of Item 1)	
17	70000641	1	Screw	
17	70000641	1	Nut	
17	70000641	1	Seal	
17	70000641	1	Spring	
17	70000641	1	Ball	
18	70000641	1	Valve, Check (Note: Part of Item 1)	
18	70000641	1	Plug	
18	70000641	1	Spring	
18	70000641	1	Poppet	
18	70000641	1	Ball	

SECTION 2 - CONTROLS

FIGURE 2-4. AC JUNCTION BOX ASSEMBLY

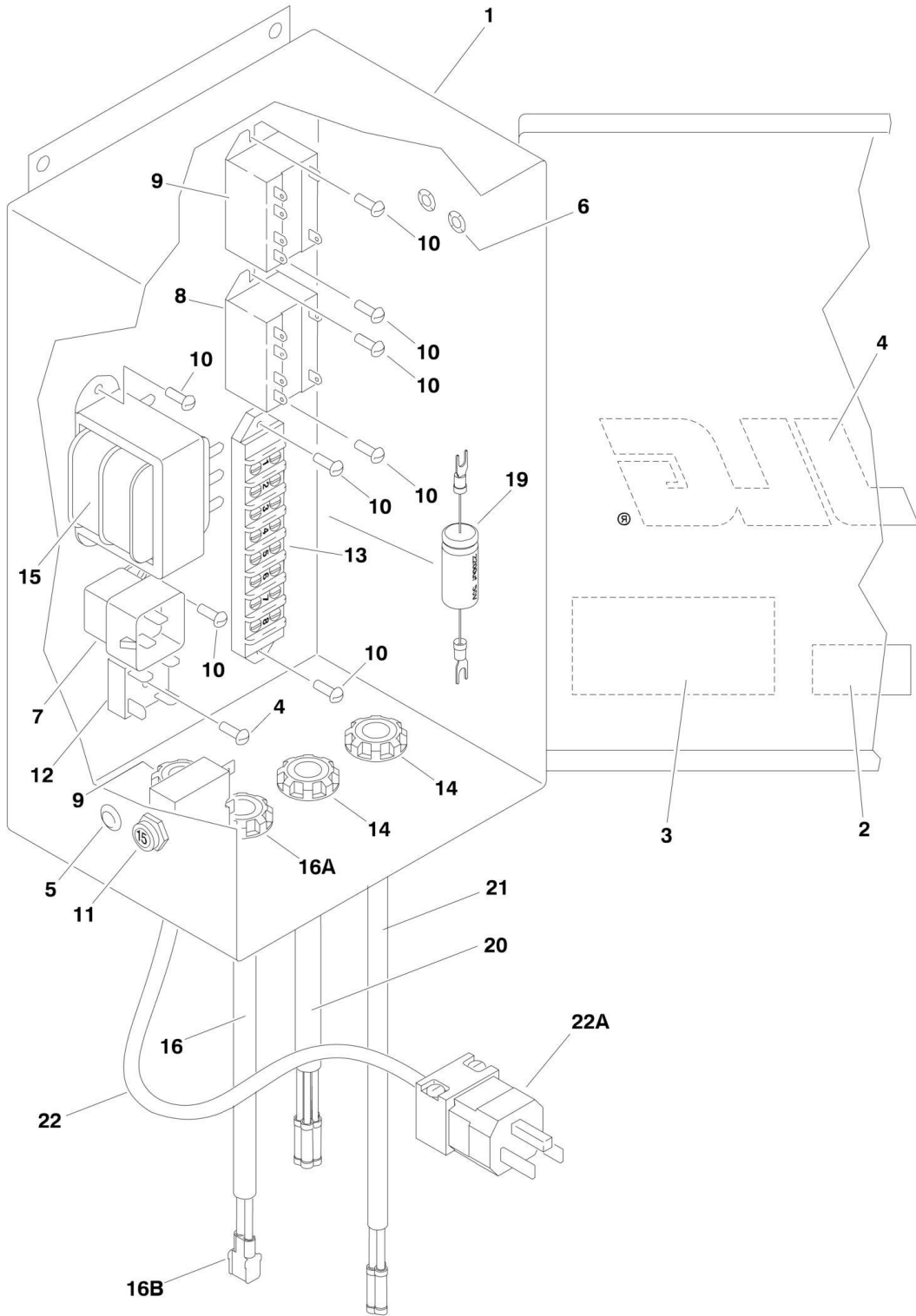

SECTION 2 - CONTROLS

FIGURE 2-4. AC JUNCTION BOX ASSEMBLY

ITEM	PART NUMBER	QTY	DESCRIPTION	REV
		Ref	JUNCTION BOX ASSEMBLY	
	1001111733	Ref	120 VAC, 60Hz (All Machines) (Excluding SN 0130005748)	C
	0861476	Ref	120 VAC, 60Hz (Including SN 0130005748)	2/B
	1001147215	Ref	120 VAC, 50-60Hz	B
	1001144703	Ref	220 VAC, 50-60Hz	B
1	0860943	1	Box with Lid	
1	70005373	1	Lid Clamp and Screw Kit	
2		Ref	Decal Options:	
2	1702102	1	Decal - 115V-1PH-50/60Hz	
2	1702569	1	Decal - 115V-1PH-60Hz	
2	1702103	1	Decal - 230V-1PH-50/60Hz	
3	1702120	1	Decal - Wire Size	
4		Ref	Decal - JLG Options:	
4	1703681	1	Decal - JLG All Machines (Excluding SN 0130005748)	
4	1702365	NLA	Decal - JLG (use p/n 1703681) (Including SN 0130005748)	
5	3520028	1	Plug (115V Only)	
6	3520034	4	Plug	
7	3740049	1	Relay	
8		Ref	Relay, Starter Options:	
8	3740093	1	115V	
8	3740105	1	230V	
9	3740094	1	Relay, Starter 12 VDC	
10	3910808	AR	Screw #8-32NF x 1/2in	
11		Ref	Circuit Breaker Options:	
11	4360161	1	115V	
11	4360070	2	230V	
12	4360376	1	Rectifier	
13	4460565	1	Strip, Terminal	
14	4460633	3	Connector, Strain Relief	
15		Ref	Transformer Options:	
15	4530010	1	120 VAC, 60Hz (All Machines) (Excluding SN 0130005748)	
15	4530013	1	120 VAC, 60Hz (Including SN 0130005748)	
15	4530023	1	120 VAC, 50-60Hz	
15	4530010	1	220 VAC, 50-60Hz	
16	4922546	1	Harness, Ground Controls	I
16A	4460633	1	Connector, Strain Relief	
16B	4460424	1	Receptacle, Female - 2 Position	
16B	4460268	2	Socket, Female	
17		Ref	Harness, Junction Box Options (Not Shown):	
17	4923131	1	120 VAC, 60Hz	B
17	4923150	1	120 VAC, 50-60Hz	B
17	4923151	1	220 VAC, 50-60Hz	B
17	2400006	1	Fuse - 5 Amp	
17	4460044	1	Fuseholder	
18	4933305	1	Diagram, Junction Box (Not Shown - See ELECTRICAL SECTION)	
19	1001093646	1	Harness, Capacitor	A
20	1001096586	1	Harness, 16/5 (See ELECTRICAL SECTION for Breakdown)	A
21	1001096587	1	Harness, 12/3 (See ELECTRICAL SECTION for Breakdown)	B
22		Ref	Harness, AC Plug Options:	

SECTION 2 - CONTROLS

ITEM	PART NUMBER	QTY	DESCRIPTION	REV
22	1001111735	1	Harness, AC for All Machines (Excluding SN 0130005748)	A
22	Not Available	1	Plug (Purchase Locally)	
22	4922645	1	Harness, AC (Including SN 0130005748)	A
22A	4460549	1	Plug (Including SN 0130005748)	

SECTION 2 - CONTROLS

FIGURE 2-5. CABLES AND CONTROLS INSTALLATION (15BD WITH PUSH BUTTON CONTROLS)

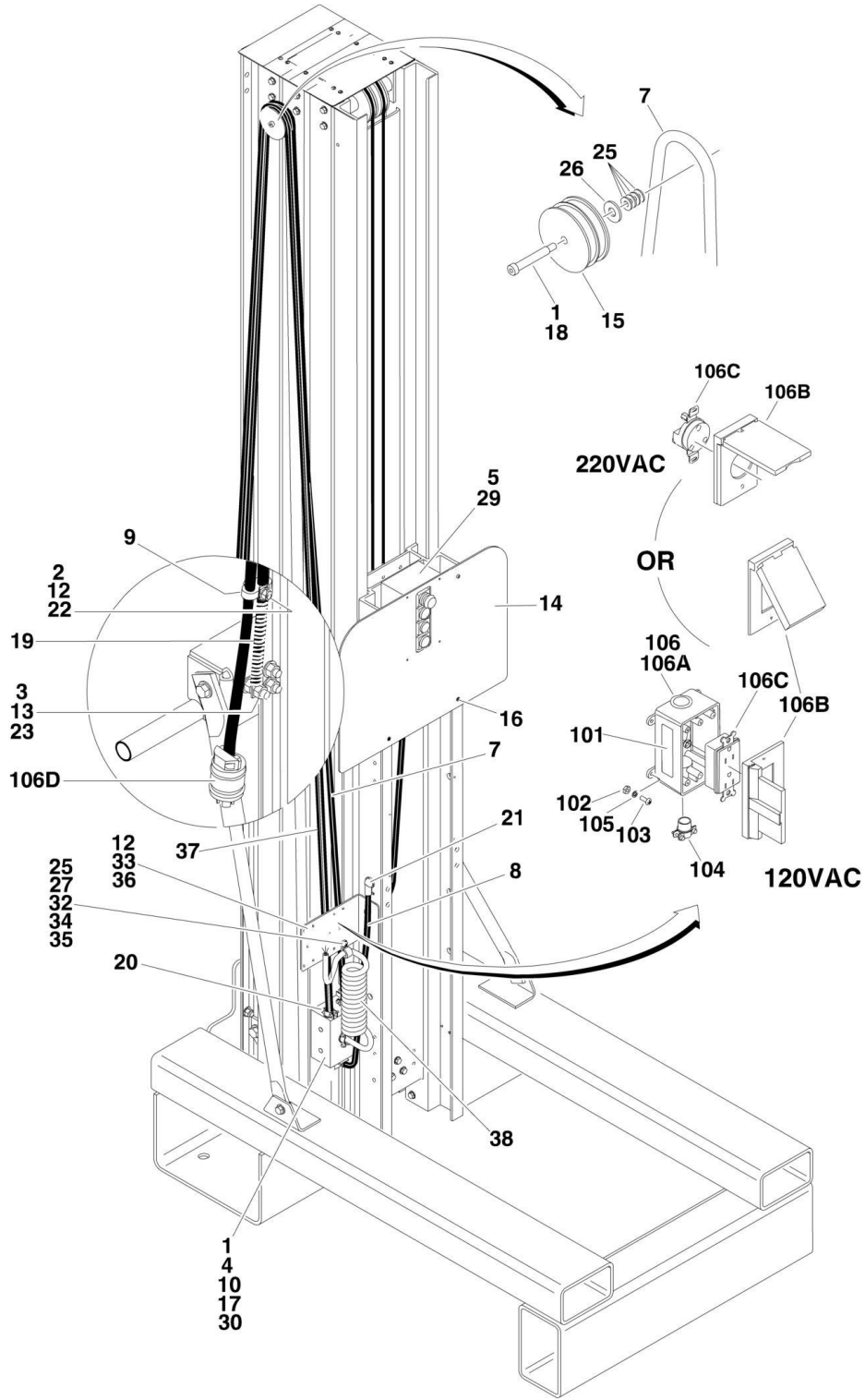

SECTION 2 - CONTROLS

FIGURE 2-5. CABLES AND CONTROLS INSTALLATION (15BD WITH PUSH BUTTON CONTROLS)

ITEM	PART NUMBER	QTY	DESCRIPTION	REV
		Ref	CABLES AND CONTROLS INSTALLATION - 15BD	
	0270490	Ref	Cables and Controls Installation All Machines (Excluding SN 0130005748)	F
	0270489	Ref	Cables and Controls Installation (Including SN 0130005748)	C
1	0100011	AR	Compound, Locking	
2	0641410	1	Bolt 1/4in-20NC x 1-1/4in	
3	0641612	1	Bolt 3/8in-16NC x 1-1/2in	
4	0860945	1	Box, Junction	
5	0861207	1	Control Box Assembly	E
5	7020078	1	Switch, Push-Pull (Red)	
5	7020088	2	Switch, Push Button (White)	
5	7020089	1	Switch, Push Button (Green)	
5	7020091	1	Plug	
5	7027299	1	Connector, Strain Relief	
5	7020093	4	Screw M3 x 25mm	
7		Ref	Cable, Electrical - 16/5 Options:	
7	1060922	1	Cable, Electrical - 16/5 All Machines (Excluding SN 0130005748)	C
7	1060687	1	Cable, Electrical - 16/5 (use p/n 4923163) (Including SN 0130005748)	A
8		Ref	Cable, Retractable - 16/5 Options:	
8	4922652	1	Cable, Retractable - 16/5 All Machines (Excluding SN 0130005748)	C
8	1060694	1	Cable, Retractable - 16/5 (Including SN 0130005748)	D
9	1320149	1	Clamp	
10	1670603	1	Cover, Junction Box	
12	3311405	3	Locknut 1/4in-20NC	
13	3311605	2	Locknut 3/8in-16NC	
14	3570923	1	Plate, Decal Mounting	
15		Ref	Sheave, Control Cable Options:	
15	3580344	1	Sheave, Control Cable All Machines (Excluding SN 0130005748)	
15	3580231	1	Sheave, Control Cable (Including SN 0130005748)	
16	3820032	4	Rivet	
17	3900191	2	Screw, Panhead	
18		Ref	Screw, Shoulder Options:	
18	3900373	1	Screw, Shoulder All Machines (Excluding SN 0130005748)	
18	3900200	1	Screw, Shoulder (Including SN 0130005748)	
19	4160130	1	Spring, Extension	
20	4460023	3	Connector, Strain Relief	
21	4460566	2	Connector, Strain Relief - 90	
22	4711400	2	Flatwasher 1/4in Thin	
23	4711600	2	Flatwasher 3/8in Thin	
25	4751000	5	Flatwasher #10 Regular	
26	4751500	1	Flatwasher 5/16in Regular	
27	4761000	3	Lockwasher #10	
29	4922420	1	Harness, Jumper (Control Box)	1/C
29	3990010	1	Diode 6 Amp	
30	3520034	2	Plug, 5/16in Hole	
32	1320041	1	Clamp, 1/2in	
33	1001096054	1	Plate, AC Box Mounting	

SECTION 2 - CONTROLS

ITEM	PART NUMBER	QTY	DESCRIPTION	REV
34	3311001	1	Nut, #10-24NC	
35	3900205	1	Screw, #10-24NC x 5/8in	
36	0641407	2	Screw, 1/4in-20NC x 7/8in	
37		Ref	Cable, Accessory - 12/3	
37	1060924	1	12/3 Cable (All Machines) (Excluding SN 0130005748)	D
37	1060564	1	12/4 Cable (Including SN 0130005748)	-
38		Ref	Cable, Retractable Options:	
38	4922653	1	16/4 Cable (All Machines) (Excluding SN 0130005748)	C
38	1060565	1	16/4 Cable (Including SN 0130005748)	B
		Ref	ACCESSORY OUTLET INSTALLATIONS	
	1001097212	Ref	120V GFI (AC) (All Machines) (Excluding SN 0130005748)	A
	0270972	Ref	120V (AC) (Including SN 0130005748)	A
	1001144987	Ref	220V (AC)	A
101		Ref	Decal Options:	
101	3252761	1	Decal - 120V	
101	3252760	1	Decal - 220V	
102	3311001	4	Nut #10-24NC	
103		Ref	Screw Options: #10-24NC x 1/4in	
103	3900205	4	Screw #10-24NC x 1/4in	
103	0721006	4	Screw #10-24NC x 3/4in	
104	4460023	1	Terminal, Connector	
105	4761000	4	Lockwasher #10	
106		Ref	Box, Plug and Receptacle Assembly Options:	
106	1001096767	1	120V GFI (AC) (All Machines) (Excluding SN 0130005748)	
106	Not Available		120V (AC) (Purchase Individual Components) (Including SN 0130005748)	
106	Not Available		220V (AC) (Purchase Individual Components)	
106A		Ref	Receptacle, Box Options:	
106A	0861731	1	Receptacle, Box All Machines (Excluding SN 0130005748)	
106A	0860946	1	Receptacle, Box (Including SN 0130005748)	
106B		Ref	Receptacle, Cover Options:	
106B	4060700	1	120V GFI (AC) Cover (Side Hinged) (Prior to SN 0130013095)	
106B	1001110873	1	120V GFI (AC) Cover (Top Hinged) (SN 0130013095 to Present)	
106B	4060092	1	120V (AC) Cover (Including SN 0130005748)	
106B	1001145894	1	220V (AC)	
106C		Ref	Receptacle Options:	
106C	4460346	1	120V GFI (AC) (All Machines) (Excluding SN 0130005748)	
106C	4460190	1	120V (AC) (Including SN 0130005748)	
106C	1001145893	1	220V (AC)	
106D		Ref	Plug Options:	
106D	4460549	1	120V	
106D	1001145887	1	220V	

SECTION 2 - CONTROLS

FIGURE 2-6. CABLES AND CONTROLS INSTALLATION (15BD WITH FOOT CONTROLS)

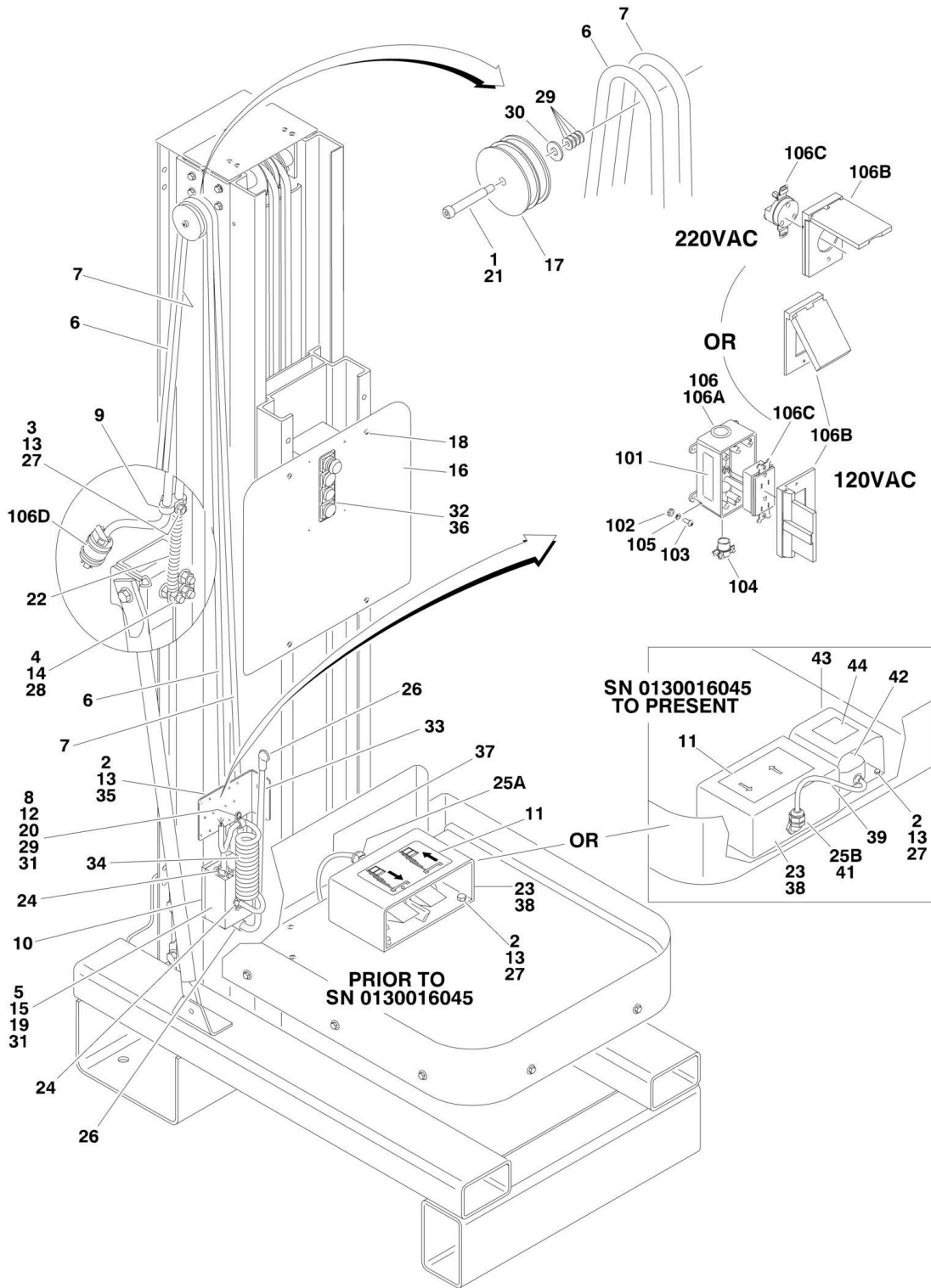

SECTION 2 - CONTROLS

FIGURE 2-6. CABLES AND CONTROLS INSTALLATION (15BD WITH FOOT CONTROLS)

ITEM	PART NUMBER	QTY	DESCRIPTION	REV
	1001111732	Ref	CABLES AND CONTROLS INSTALLATION - 15BD	C
1	0100011	AR	Compound, Locking	
2	0641407	10	Bolt 1/4in-20NC x 7/8in	
3	0641410	1	Bolt 1/4in-20NC x 1-1/4in	
4	0641612	1	Bolt 3/8in-16NC x 1-1/2in	
5	0860945	1	Box, Junction	
6	1060922	1	Cable, Electrical - 16/5	
7	1060924	1	Cable, Accessories	
8	1320041	1	Clamp	
9	1320149	1	Clamp	
10	1670603	1	Cover, Junction Box	
11	1703166	1	Decal - Footswitch	
12	3311001	1	Nut #10-24NC	
13	3311405	11	Locknut 1/4in-20NC	
14	3311605	2	Locknut 3/8in-16NC	
15	3520034	2	Plug	
16		Ref	Plate, Decal Mounting Options:	
16	3570923	1	Plate, Decal Mounting (Prior to SN 0130017911)	
16	1001133248	1	Plate, Decal Mounting (SN 0130017911 to Present)	
17	3580344	1	Sheave, Control Cable	
18	3820032	4	Rivet	
19	3900191	2	Screw, Panhead	
20	3900205	1	Screw #10-24NC x 5/8in	
21	3900373	1	Screw, Shoulder	
22	4160130	1	Spring, Extension	
23	4360384	1	Footswitch Assembly	
23	7020183	2	Switch, Interior Plunger	
24	4460023	3	Connector, Strain Relief	
25		Ref	Connector, Weather Tight Options:	
25A	4460071	1	Connector, Strain Relief - Straight	
25B	1001133248	1	Connector, Strain Relief - 90	
26	4460566	2	Connector, Strain Relief - 90	
27	4711400	10	Flatwasher 1/4in Thin	
28	4711600	2	Flatwasher 3/8in Thin	
29	4751000	5	Flatwasher #10 Regular	
30	4751500	1	Flatwasher 5/16in Regular	
31	4761000	3	Lockwasher #10	
32	1001111820	1	Harness, Platform Controls	A
33	4922652	1	Cable, Retractable 16/5	C
34	4922653	1	Cable, Retractable 16/3	C
35	1001096054	1	Plate, AC Box Mounting	
36	1001111595	1	Box, Platform Control	A
36	7020078	1	Switch, Push-Pull (Red)	
36	7020088	2	Switch, Push Button (White)	
36	7020089	1	Switch, Push Button (Green)	
36	7027299	1	Connector, Strain Relief	
36	4460445	1	Receptacle, Female 3 Position	
36	4460268	3	Socket, Female	
36	4460424	1	Receptacle, Female 2 Position	
36	4460267	2	Pin, Male	

SECTION 2 - CONTROLS

ITEM	PART NUMBER	QTY	DESCRIPTION	REV
36	7020093	4	Screw M3 x 25mm	
37	1001111744	1	Harness, Footswitch Only (Prior to SN 0130016045)	A
37	4460326	1	Plug, Male 3 Position	
37	4460267	3	Pin, Male	
38	1001111750	1	Harness, Jumper	A
39	1001133135	1	Harness, Footswitch Enable Only (SN 0130016045 to Present)	A
40	4240033	AR	Tie-Strap (Not Shown)	
41	1001133137	1	Harness, Footswitch Only (SN 0130016045 to Present)	A
41	4460326	1	Plug, Male 3 Position	
41	4460267	3	Pin, Male	
42	1001129307	1	Footswitch Assembly (Single Only) (SN 0130016045 to Present)	
43	1001129306	1	Cover, Footswitch (Single Only) (SN 0130016045 to Present)	
44	3252347	1	Nameplate, Footswitch Only (SN 0130017911 to Present)	
		Ref	ACCESSORY OUTLET INSTALLATIONS	
	1001097212	Ref	120V GFI (AC)	A
	1001144987	Ref	220V (AC)	A
101		Ref	Decal Options:	
101	3252761	1	Decal - 120V	
101	3252760	1	Decal - 220V	
102	3311001	4	Nut #10-24NC	
103		Ref	Screw Options:	
103	3900205	4	Screw #10-24NC x 1/4in	
103	0721006	4	Screw #10-24NC x 3/4in	
104	4460023	1	Terminal, Connector	
105	4761000	4	Lockwasher #10	
106		Ref	Box, Plug and Receptacle Assembly Options:	
106	1001096767	1	120V GFI (AC)	B
106	Not Available		220V (AC) (Purchase Individual Components)	
106A	0861731	1	Box, Receptacle	
106B		Ref	Cover, Receptacle Options:	
106B	4060700	1	120V GFI (AC) Cover (Side Hinged) (Prior to SN 0130013095)	
106B	1001110873	1	120V GFI (AC) Cover (Top Hinged) (SN 0130013095 to Present)	
106B	1001145894	1	220V (AC)	
106C		Ref	Receptacle Options:	
106C	4460346	1	120V GFI (AC)	
106C	1001145893	1	220V (AC)	
106D		Ref	Plug Options:	
106D	4460549	1	120V	
106D	1001145887	1	220V	

SECTION 2 - CONTROLS

FIGURE 2-7. CABLES AND CONTROLS INSTALLATION (19BD WITH FOOT CONTROLS)

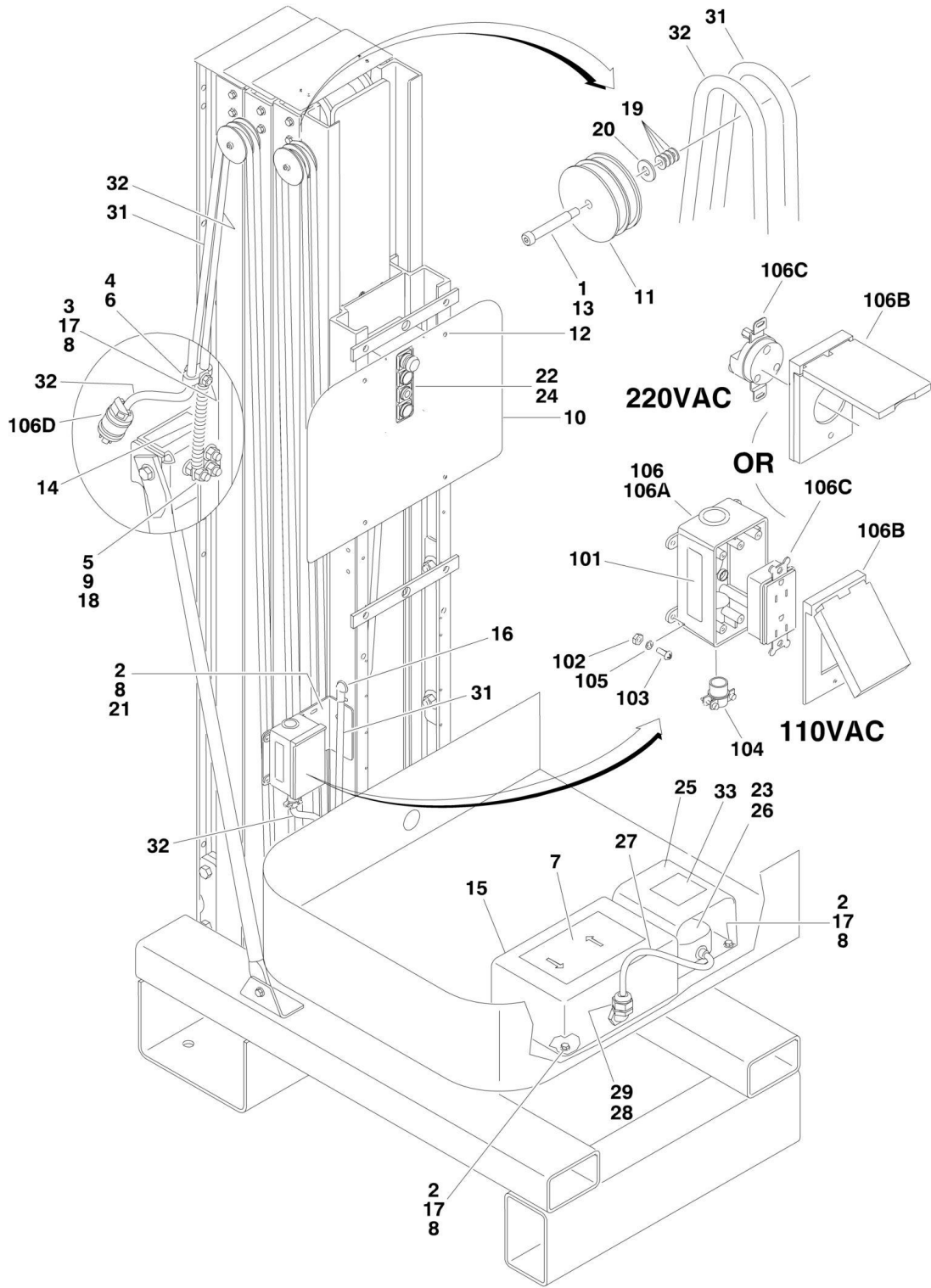

SECTION 2 - CONTROLS

FIGURE 2-7. CABLES AND CONTROLS INSTALLATION (19BD WITH FOOT CONTROLS)

ITEM	PART NUMBER	QTY	DESCRIPTION	REV
	1001128986	Ref	CABLES AND CONTROLS INSTALLATION - 19BD	D
1	0100011	AR	Compound, Locking	
2	0641407	10	Bolt 1/4in-20NC x 7/8in	
3	0641410	1	Bolt 1/4in-20NC x 1-1/4in	
4	0641418	1	Bolt 1/4in-20NC x 2-1/4in	
5	0641612	1	Bolt 3/8in-16NC x 1-1/2in	
6	1320149	3	Clamp	
7	1703166	1	Decal - Footswitch	
8	3311405	11	Locknut 1/4in-20NC	
9	3311605	2	Locknut 3/8in-16NC	
10		Ref	Plate, Decal Mounting Options:	
10	3570923	1	Plate, Decal Mounting (Prior to SN 0130017911)	
10	1001133248	1	Plate, Decal Mounting (SN 0130017911 to Present)	
11	3580344	3	Sheave, Control Cable	
12	3820032	4	Rivet	
13	3900373	1	Screw, Shoulder	
14	4160130	1	Spring, Extension	
15	4360384	1	Footswitch Assembly (Double)	
15	7020183	2	Switch, Interior Plunger	
16	4460566	2	Connector, Strain Relief - 90	
17	4711400	10	Flatwasher 1/4in Thin	
18	4711600	2	Flatwasher 3/8in Thin	
19	4751000	12	Flatwasher #10 Regular	
20	4751500	1	Flatwasher 5/16in Regular	
21	1001096054	1	Plate, AC Box Mounting	
22	1001111595	1	Box, Platform Control	A
22	7020078	1	Switch, Push-Pull (Red)	
22	7020088	2	Switch, Push Button (White)	
22	7020089	1	Switch, Push Button (Green)	
22	7027299	1	Connector, Strain Relief	
22	4460445	1	Receptacle, Female 3 Position	
22	4460268	3	Socket, Female	
22	4460424	1	Receptacle, Female 2 Position	
22	4460267	2	Pin, Male	
22	7020093	4	Screw M3 x 25mm	
23	1001111750	1	Harness, Jumper	A
24	1001111820	1	Harness, Platform Controls	A
25	1001129306	1	Cover, Footswitch (Single)	
26	1001129307	1	Footswitch Assembly (Single)	
27	1001133135	1	Harness, Footswitch Enable	A
28	1001133137	1	Harness, Footswitch	A
28	4460326	1	Plug, Male 3 Position	
28	4460267	3	Pin, Male	
29	1001133248	1	Connector, 90 Strain Relief	
30	4240033	AR	Tie-Strap (Not Shown)	
31		Ref	Harness, Accessories Cable Options:	
31	1060926	1	Harness, Accessories Cable (Prior to SN 0130019651)	
31	1001156552	1	Harness, Accessories Cable (SN 0130019651 to Present)	
31	1060663	AR	12/3 Electrical Cable Options:	
31	1060663	21 ft/6.4m	Harness p/n 1060926	

SECTION 2 - CONTROLS

ITEM	PART NUMBER	QTY	DESCRIPTION	REV
31	1060663	22.25 ft/6.8m	Harness p/n 1001156552	
31	4460315	3	Terminal Fork	
32	4922657	1	Harness, Platform Cable	
32	1060687	25.3 ft/7.4m	16/5 Electrical Cable	
32	4460115	4	Terminal Fork	
33	3252347	1	Nameplate, Footswitch Only (SN 0130017911 to Present)	
		Ref	ACCESSORY OUTLET INSTALLATIONS	
	1001097212	Ref	120V GFI (AC)	A
	1001144987	Ref	220V (AC)	A
101		Ref	Decal Options:	
101	3252761	1	Decal - 120V	
101	3252760	1	Decal - 220V	
102	3311001	4	Nut #10-24NC	
103		Ref	Screw Options:	
103	3900205	4	Screw #10-24NC x 1/4in	
103	0721006	4	Screw #10-24NC x 3/4in	
104	4460023	1	Terminal, Connector	
105	4761000	4	Lockwasher #10	
106		Ref	Box, Plug and Receptacle Assembly Options:	
106	1001096767	1	120V GFI (AC)	B
106	Not Available		220V (AC) (Purchase Individual Components)	
106A	0861731	1	Box, Receptacle	
106B		Ref	Cover, Receptacle Options:	
106B	1001110873	1	120V GFI (AC) Cover (Top Hinged)	
106B	1001145894	1	220V (AC)	
106C		Ref	Receptacle Options:	
106C	4460346	1	120V GFI (AC)	
106C	1001145893	1	220V (AC)	
106D		Ref	Plug Options:	
106D	4460549	1	120V	
106D	1001145887	1	220V	

SECTION 3 - MAST

SECTION 3 - MAST

FIGURE 3-1. MAST ASSEMBLY (15BD)

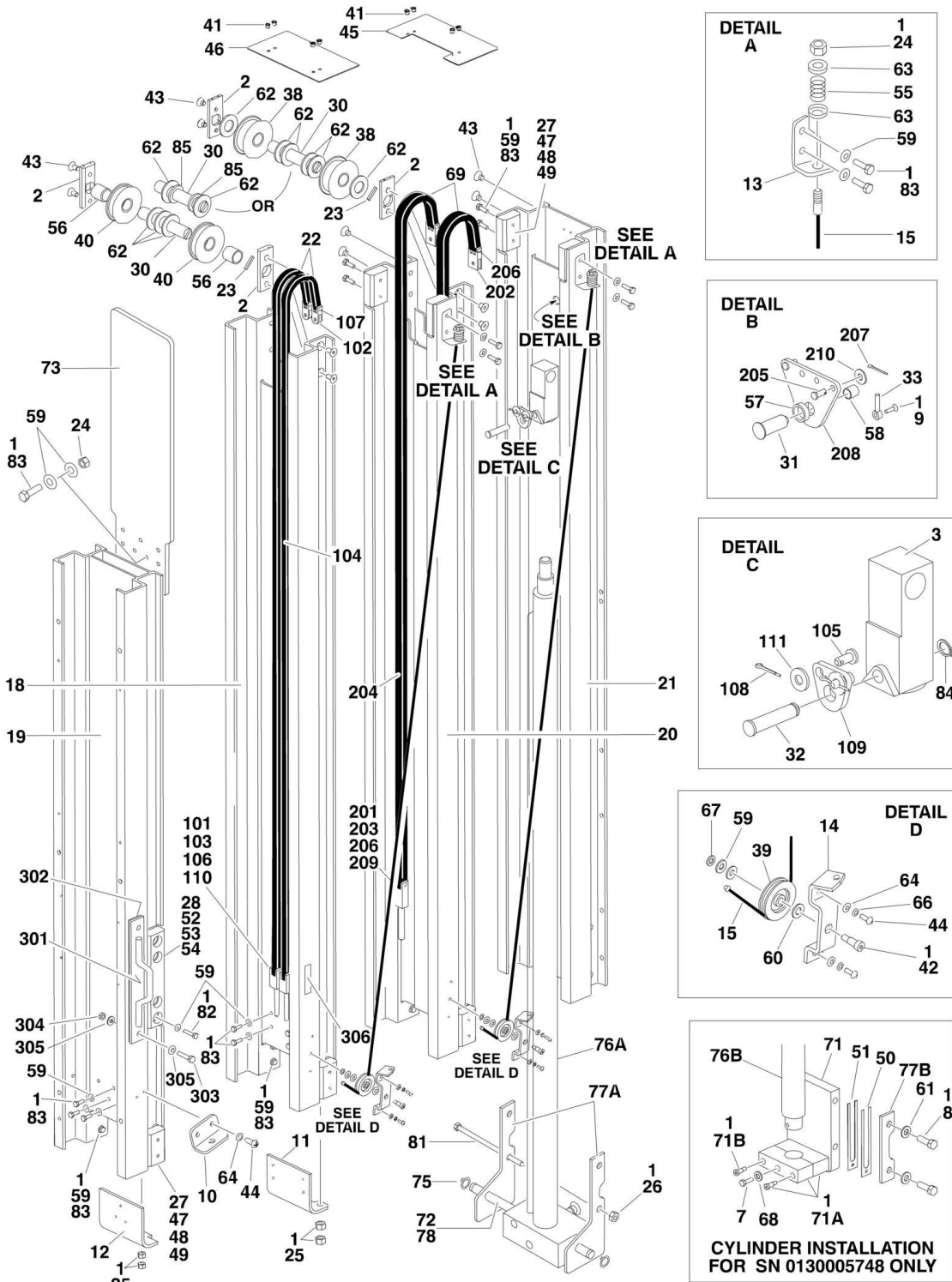

SECTION 3 - MAST

FIGURE 3-1. MAST ASSEMBLY (15BD)

ITEM	PART NUMBER	QTY	DESCRIPTION	REV
		Ref	MAST ASSEMBLY - 15BD	
	0801321	Ref	Mast Assembly All Machines (Excluding SN 0130005748)	F
	0801328	Ref	Mast Assembly (Including SN 0130005748)	C
1	0100011	AR	Compound, Locking	
2	0362735	4	Bar, Sheave Pin Support	
3	0561341	1	Block, Chain Anchor	
7	0641508	1	Bolt 5/16in-18NC x 1in (Including SN 0130005748)	
8	0641812	4	Bolt 1/2in-13NC x 1-1/2in (Including SN 0130005748)	
9	0741006	1	Screw #10-24NC x 3/4in	
10	0902047	1	Bracket, Sequence Cable	
11	0902422	1	Bracket, Bottom Chain Attach	
12	0902423	1	Bracket, Bottom Chain Attach	
13	0902431	2	Bracket, Sequence Cable	
14	0902445	2	Bracket, Sequence Cable	
15	1060683	2	Cable, Sequence	
18	1271392	1	Channel, Mast #3	
19		Ref	Channel, Mast Header Options:	
19	1001111558	1	Channel, Mast Header All Machines (Excluding SN 0130005748)	
19	1271519	1	Channel, Mast Header (Including SN 0130005748)	
20		Ref	Channel, Mast #2 Options:	
20	1001111560	1	Channel, Mast #2 All Machines (Excluding SN 0130005748)	
20	1271421	1	Channel, Mast #2 (Including SN 0130005748)	
21	1271515	1	Channel, Mast #1	
22	1260356	1	Chain Assembly #444 (See Items 101-111 for Breakdown)	
23	2880310	2	Key	
24	3311401	6	Nut 1/4in-20NC	
25	3311601	8	Nut 3/8in-16 NC	
26	3311801	2	Nut 1/2in-13NC	
27	3340845	10	Pad, Slide Guide	
28	3340858	NLA	Pad, Slide Guide (Use p/n 1001235146) (Prior to SN 0130033333)	
28	1001235146	2	Pad, Slide Guide (SN 0130033333 to Present)	
30	3422717	2	Pin, Sheave	
31	3422750	1	Pin, Chain Equalizer	
32	3422752	1	Pin, Chain Equalizer	
33	3422757	1	Pin, Keeper	
38	3580286	2	Sheave Assembly	
38	0440246	2	Bearing (1 Per Assembly)	
39	3580269	2	Sheave Assembly	
40	3580293	2	Sheave Assembly	
40	0440249	2	Bearing (1 Per Assembly)	
41	3820034	8	Rivet	
42	3900187	2	Screw, Shoulder	
43	3900192	8	Screw 3/8in-16NC x 1/2in	
44	3900205	6	Bolt #10-24NC x 5/8in	
45	4060960	1	Shield, Mast Cover	
46	4060961	1	Shield, Mast Cover	
47	4070860	AR	Shim, Slide Pad	
48	4070861	AR	Shim, Slide Pad	

SECTION 3 - MAST

ITEM	PART NUMBER	QTY	DESCRIPTION	REV
49	4070862	AR	Shim, Slide Pad	
50	4070970	2	Shim, Cylinder Mount (Including SN 0130005748)	
51	4070971	4	Shim, Cylinder Mount (Including SN 0130005748)	
52	4070988	2	Shim, Slide Pad	
53	4070989	2	Shim, Slide Pad	
54	4070990	2	Shim, Slide Pad	
55	4160124	2	Spring	
56	4567491	2	Tube, Spacer	
57	4567750	1	Tube, Spacer	
58	4567751	1	Tube, Spacer	
59	4711400	47	Flatwasher 1/4in Thin	
60	4711500	2	Flatwasher 5/16in Thin	
61	4711800	4	Flatwasher 1/2in Thin (Including SN 0130005748)	
62	4740007	AR	Thrustwasher	
63	4740414	4	Washer, Cup	
64	4750800	6	Flatwasher #8 Regular	
66	4761000	6	Lockwasher #10	
67	4761400	2	Lockwasher 1/4in	
68	4761500	1	Lockwasher 5/16in (Including SN 0130005748)	
69	1260361	1	Chain Assembly #466 (See Items 201-210 for Breakdown)	
71	4846381	1	Mount, Cylinder (Including SN 0130005748)	
71	3572847	1	Mount Assembly	
71A	3900163	2	Screw, Socket Head 3/8in-16NC x 2in	
71B	4846481	1	Bracket, Bottom Chain Attach	
72	3020039	AR	Lubricant	
73	1671255	1	Cover, Mast Chain	
75	3760348	2	Ring, Retaining	
76		Ref	Lift Cylinder Assy Options (See CYLINDER SECTION for Breakdown):	
76A	1001099734	1	Lift Cylinder Assy All Machines (Excluding SN 0130005748)	
76B	1684088	1	Lift Cylinder Assy (Including SN 0130005748)	
77		Ref	Mount, Lift Cylinder Options:	
77A	1001099754	4	Mount, Lift Cylinder All Machines (Excluding SN 0130005748)	
77B	3570893	2	Mount, Lift Cylinder (Including SN 0130005748)	
78	1001100013	1	Pin, Cylinder	
81	0641872	2	Bolt 1/2in-13NC x 9in	
82	0681410	8	Bolt 1/4in-20NC x 1-1/4in (Grade 8)	
83		Ref	Bolt Options:	
83	0641406	AR	Bolt 1/4in-20NC x 3/4in	
83	0641407	AR	Bolt 1/4in-20NC x 7/8in	
83	0641408	AR	Bolt 1/4in-20NC x 1in	
84	3760383	1	Retainer, Ring	
85	4892600	2	Washer 1in (SN 0130033333 to Present)	
		Ref	Mast Kit Options (Includes Items 18-21):	
	2902179	1	Mast Kit All Machines (Excluding SN 0130005748)	
	2902178	1	Mast Kit (Including SN 0130005748)	
	1260356	Rev.	CHAIN ASSEMBLY - #444 CHAIN	E
101	0100062	AR	Compound, Locking (use p/n 0100019)	
102	0561149	2	Block, Chain Anchor	
103	0561408	2	Block, Chain Anchor	
104	Purchased Assy	AR	Chain	
105	3422338	2	Pin, Equalizer	

SECTION 3 - MAST

ITEM	PART NUMBER	QTY	DESCRIPTION	REV
106	3422346	2	Pin, Grooved	D
107	3422355	2	Pin	
108	3450304	2	Pin, Cotter	
109	3571103	1	Plate, Chain Adjustment	
110	4300111	2	Stud	
111	4751500	2	Flatwasher 5/16in Regular	
	1260361	Rev.	CHAIN ASSEMBLY - #466 CHAIN	
201	0100062	AR	Compound, Locking (use p/n 0100019)	
202	0561153	2	Block, Chain Anchor	
203	0561409	2	Block, Chain Anchor	
204	Purchased Assy	AR	Chain	
205	3422338	2	Pin, Equalizer	3/B
206	3422346	4	Pin, Groove	
207	3450304	2	Pin, Cotter	
208	3571101	1	Plate, Chain Adjustment	
209	4300111	2	Stud	
210	4751500	2	Flatwasher 5/16in Regular	
	0256559	Ref	HARNES ATTACH INSTALLATION (OPTIONAL)	
301	4845345	1	Attachment, Safety	
302	3539814	1	Plate, Safety Attach Backing	
303	0681812	2	Bolt 1/2in-13NC x 1-1/2in (Grade 8)	
304	3271805	2	Locknut 1/2in-13NC (Grade 8)	
305	4751800	4	Flatwasher 1/2in Regular	
306	1704277	1	Decal - Lanyard Attach	

SECTION 3 - MAST

FIGURE 3-2. MAST ASSEMBLY (19BD)

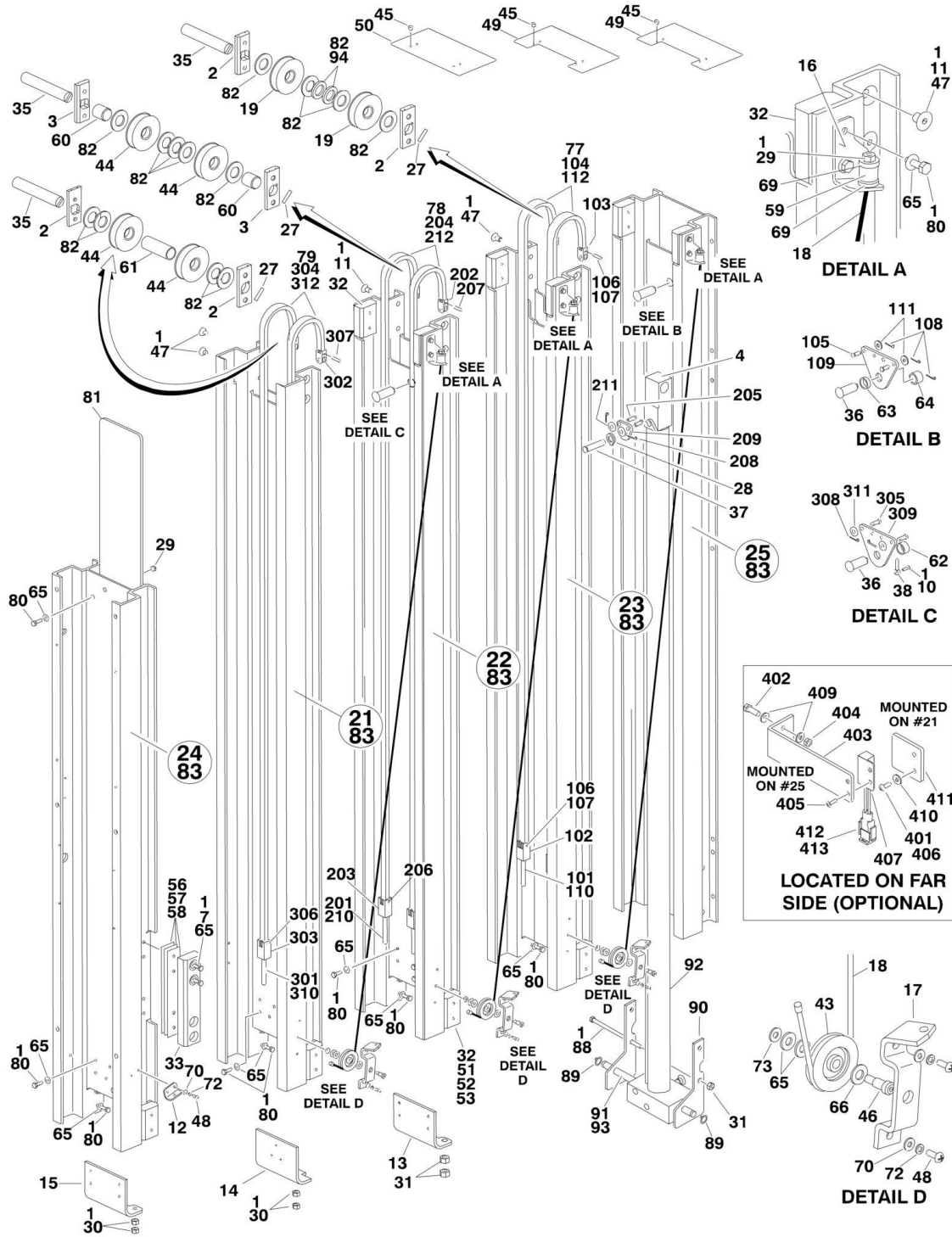

SECTION 3 - MAST

FIGURE 3-2. MAST ASSEMBLY (19BD)

ITEM	PART NUMBER	QTY	DESCRIPTION	REV
	0801409	Ref	MAST ASSEMBLY - 19BD	F
1	0100011	AR	Compound, Locking	
2	0362735	4	Bar, Sheave Pin Support	
3	0362736	2	Bar, Sheave Pin Support	
4	0561341	1	Block, Chain Anchor	
7	0681410	8	Bolt 1/4in-20NC x 1-1/4in Grade 8	
10	0741006	2	Bolt #10-24NC x 3/4in	
11	0741606	4	Bolt 3/8in-16NC x 3/4in	
12	0902047	1	Bracket, Sequence Cable	
13	0902422	1	Bracket, Bottom Chain Attach	
14	0902423	1	Bracket, Bottom Chain Attach	
15	0902424	1	Bracket, Bottom Chain Attach	
16	0902431	3	Bracket, Sequence Cable	
17	0902445	3	Bracket, Sequence Cable	
18	1060683	3	Cable, Sequence	
19	3580286	2	Sheave Assembly	
21	1271392	1	Channel, Mast #6	
22	1271419	1	Channel, Mast #3	
23	1271421	1	Channel, Mast #2	
24	1271446	1	Channel, Mast Header	
25	1001109405	1	Channel, Mast #1	
27	2880310	3	Key	
28	3760383	1	Ring, Retaining	
29	3311401	6	Nut 1/4in-20NC	
30	3311601	8	Nut 3/8in-16NC	
31	3311801	6	Nut 1/2in-13NC	
32	3340845	14	Pad, Slide Guide	
33	3340858	NLA	Pad, Slide Guide (Use p/n 1001235146) (Prior to SN 0130033261)	
33	1001235146	2	Pad, Slide Guide (SN 0130033261 to Present)	
35	3422717	3	Pin	
36	3422750	2	Pin	
37	3422752	1	Pin	
38	3422757	2	Pin, Keeper	
43	3580269	3	Sheave, Sequence Cable	
44	3580293	4	Sheave Assembly	
45	3820034	12	Rivet	
46	3900187	3	Screw, Shoulder	
47	3900192	8	Screw 3/8in-16NC x 1/2in	
48	3900205	8	Screw #10-24NC x 5/8in	
49	4060960	2	Shield, Mast Cover	
50	4060961	1	Shield, Mast Cover	
51	4070860	AR	Shim, Slide Pad	
52	4070861	AR	Shim, Slide Pad	
53	4070862	AR	Shim, Slide Pad	
56	4070988	AR	Shim, Slide Pad	
57	4070989	AR	Shim, Slide Pad	
58	4070990	AR	Shim, Slide Pad	
59	4160124	3	Spring	
60	4567489	2	Tube, Spacer	

SECTION 3 - MAST

ITEM	PART NUMBER	QTY	DESCRIPTION	REV
61	4567492	1	Tube, Spacer	
62	4567749	1	Tube, Spacer	
63	4567750	1	Tube, Spacer	
64	4567751	1	Tube, Spacer	
65	4711400	59	Flatwasher 1/4in Thin	
66	4711500	3	Flatwasher 5/16in Thin	
69	4740414	6	Washer, Cup	
70	4750800	8	Flatwasher #8 Regular	
72	4761000	8	Lockwasher #10	
73	4761400	3	Lockwasher 1/4in	
77	1260355	1	Chain/Clevis Assembly (#544 Chain) (See Items 101-111 for Breakdown)	
78	1260356	1	Chain/Clevis Assembly (#444) (See Items 201-211 for Breakdown)	
79	1260357	1	Chain/Clevis Assembly (#444) (See Items 301-311 for Breakdown)	
80		Ref	Bolt 1/4in-20NC Options:	
80	0641406	AR	Bolt 1/4in-20NC x 3/4in	
80	0641407	AR	Bolt 1/4in-20NC x 7/8in	
80	0641408	AR	Bolt 1/4in-20NC x 1in	
81	4060987	1	Shield, Mast	
82	4740007	AR	Thrustwasher	
83	3020041	AR	Lubricant, Krytox	
88	0641872	2	Bolt 1/2in-13NC x 9in	
89	3760348	2	Ring, Retaining	
90	1001099754	4	Mount, Cylinder	
91	1001100013	1	Pin	
92	1001100058	1	Cylinder Assembly (See CYLINDER SECTION for Breakdown)	
93	3020039	AR	Lubricant, Moly Paste	
94	4892600	2	Washer 1in (SN 0130033261 to Present)	
95	1001109315	1	Mast Kit Options (Includes Items 21 thru 25) (Not Shown)	
	1260355	Ref	CHAIN/CLEVIS ASSEMBLY- #544 CHAIN	E
101	0100062	AR	Compound, Locking (use p/n 0100019)	
102	0561308	2	Block	
103	0561336	2	Block	
104	item 112	AR	Chain	
105	3422338	2	Pin, Clevis	
106	3422720	4	Pin	
107	3450202	8	Pin, Cotter	
108	3450304	2	Pin, Cotter	
109	3571101	1	Plate, Clevis	
110	4300129	2	Stud	
111	4711500	2	Flatwasher 5/16in Thin	
112	1260343	2	Chain Kit (Includes Qty 1 of #101-103 & 110, Qty 71in/1.8m of #104, Qty 2 of #106 and Qty 4 of #107)	C
	1260356	Ref	CHAIN/CLEVIS ASSEMBLY - #444 CHAIN	E
201	0100062	AR	Compound, Locking (use p/n 0100019)	
202	0561149	2	Block	
203	0561408	2	Block	
204	Item 212	AR	Chain	
205	3422338	2	Pin, Clevis	
206	3422346	2	Pin, Groove	
207	3420355	2	Pin, Groove	
208	3450304	2	Pin, Cotter	

SECTION 3 - MAST

ITEM	PART NUMBER	QTY	DESCRIPTION	REV
209	3571103	1	Plate, Clevis	
210	4300111	2	Stud	
211	4711500	2	Flatwasher 5/16in Thin	
212	1260349	2	Chain Kit (Includes Qty 1 of #201-203, 206 & 210 and Qty 71in/1.8m of #204)	E
	1260357	Ref	CHAIN/CLEVIS ASSEMBLY - #444 CHAIN	E
301	0100062	AR	Compound, Locking (use p/n 0100019)	
302	0561149	2	Block	
303	0561408	2	Block Options	
304	item 312	AR	Chain	
305	3422338	2	Pin, Clevis	
306	3422346	2	Pin, Groove	
307	3450355	2	Pin, Groove	
308	3450304	2	Pin, Cotter	
309	3571101	1	Plate, Clevis	
310	4300111	2	Stud	
311	4711500	2	Flatwasher 5/16in Thin	
312	1260349	2	Chain Kit (Includes Qty 1 of #301-303, 306 & 310 and Qty 71in/1.8m of #304)	E
	1001128991	Ref	HEIGHT LIMITER INSTALLATION	A
401	0100011	AR	Compound, Locking	
402	0641407	2	Bolt 1/4in-20NC x 7/8in	
403	0903671	1	Bracket, Mounting	
404	3311405	2	Locknut 1/4in-20NC	
405	3820024	2	Rivet	
406	3900205	2	Screw #10-24NC x 5/8in	
407	4360515	1	Switch, Proximity	
408	4240033	AR	Tie-Strap (Not Shown)	
409	4711400	4	Flatwasher 1/4in Thin	
410	4751000	2	Flatwasher #10 Regular	
411	1001132981	1	Plate	
412	4460267	2	Pin, Male	
413	4460424	1	Connector - 2 Position	

SECTION 4 - PLATFORM

SECTION 4 - PLATFORM

FIGURE 4-1. PLATFORM WITH GULLWING GATE (15BD ONLY)

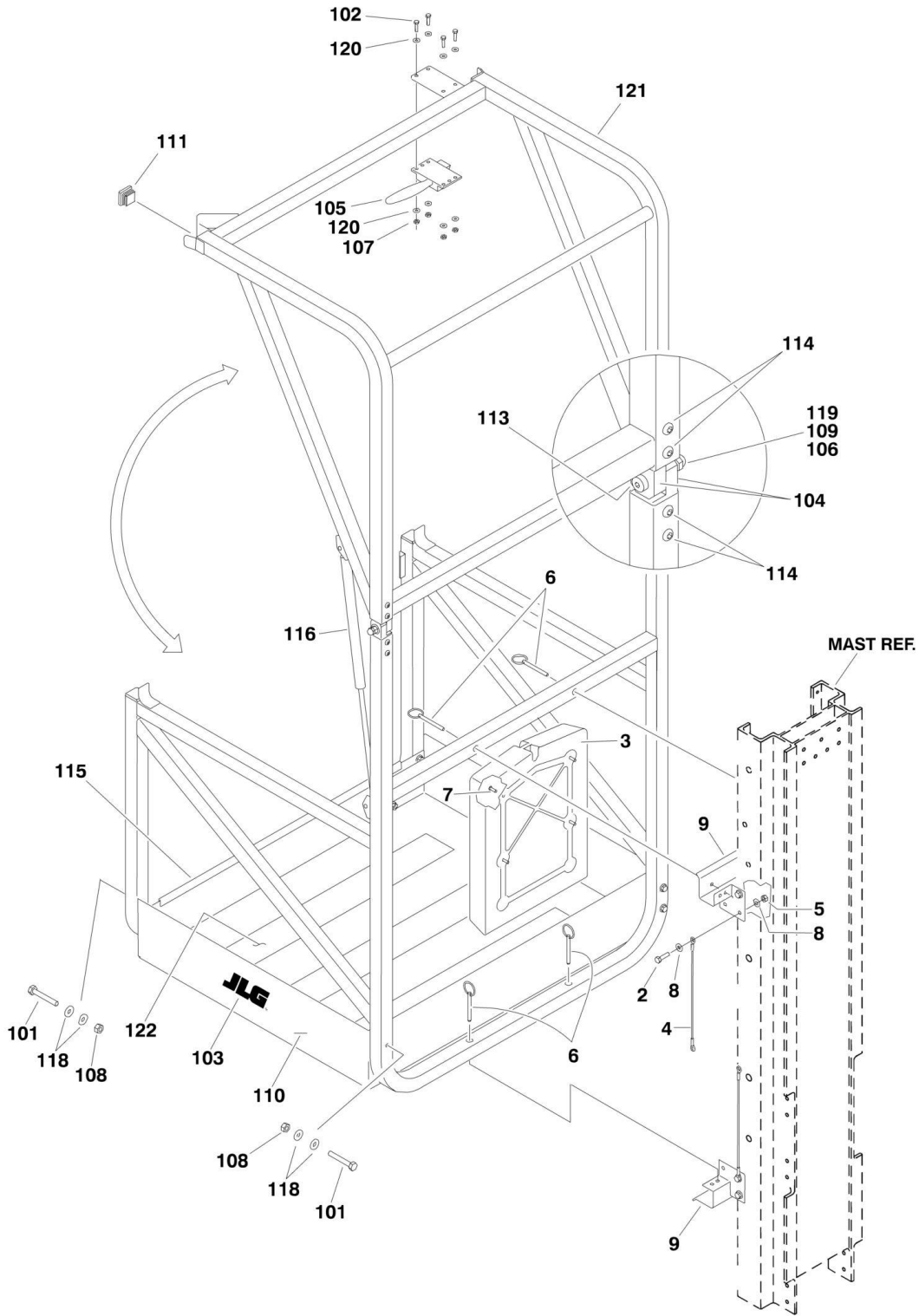

SECTION 4 - PLATFORM

FIGURE 4-1. PLATFORM WITH GULLWING GATE (15BD ONLY)

ITEM	PART NUMBER	QTY	DESCRIPTION	REV
	0258475	Ref	PLATFORM INSTALLATION - 15BD	C
1	3510905	1	Platform Assembly (See Item 101-122 for Breakdown)	
2	0641408	8	Bolt, 1/4in-20NC x 1in	
3	0860520	1	Box, Manual Storage	
4	1060380	4	Cable, Lanyard	
5	3311405	10	Locknut, 1/4in-20NC	
6	3422657	4	Pin, Quick Release	
7	3820024	4	Rivet	
8	4711400	20	Flatwasher 1/4in Thin	
9	4845821	2	Mounting Bracket Weldment	
	3510905	Ref	PLATFORM ASSEMBLY	C
101	0641414	8	Bolt 1/4in-20NC x 1-3/4in	
102	0721006	4	Bolt #10-24NC x 3/4in	
103	1703681	3	Decal - JLG	
104	2600225	4	Hinge, Gate	
105	2940074	1	Latch	
106	3300356	2	Nut, Acorn 5/16in-18NC	
107	3311005	4	Locknut #10-24NC	
108	3311405	8	Locknut 1/4in-20NC	
109	3311505	2	Locknut 5/16in-18NC	
110	3510904	1	Plate, Platform Pan	
111	3520072	4	Cap, Plug	
112	3641663	1	Rail Weldment	
113	3900032	2	Bolt, Shoulder	
114	3900258	8	Screw, Button Head 1/4in-20NC x 3/4in	
115	4060803	29 in/74cm	Flex-Trim	
116	4160165	1	Spring, Gas Shock	
118	4711400	16	Flatwasher 1/4in Thin	
119	4711600	2	Flatwasher 3/8in Thin	
120	4751000	8	Flatwasher #10 Regular	
121	4845813	1	Gullwing Gate Weldment	
122	1001099638	3	Tape, Non-Skid (23in/58.5cm Lengths)	

SECTION 4 - PLATFORM

FIGURE 4-2. PLATFORM (27IN/69CM X 23IN/58.5CM) WITH SWING GATE

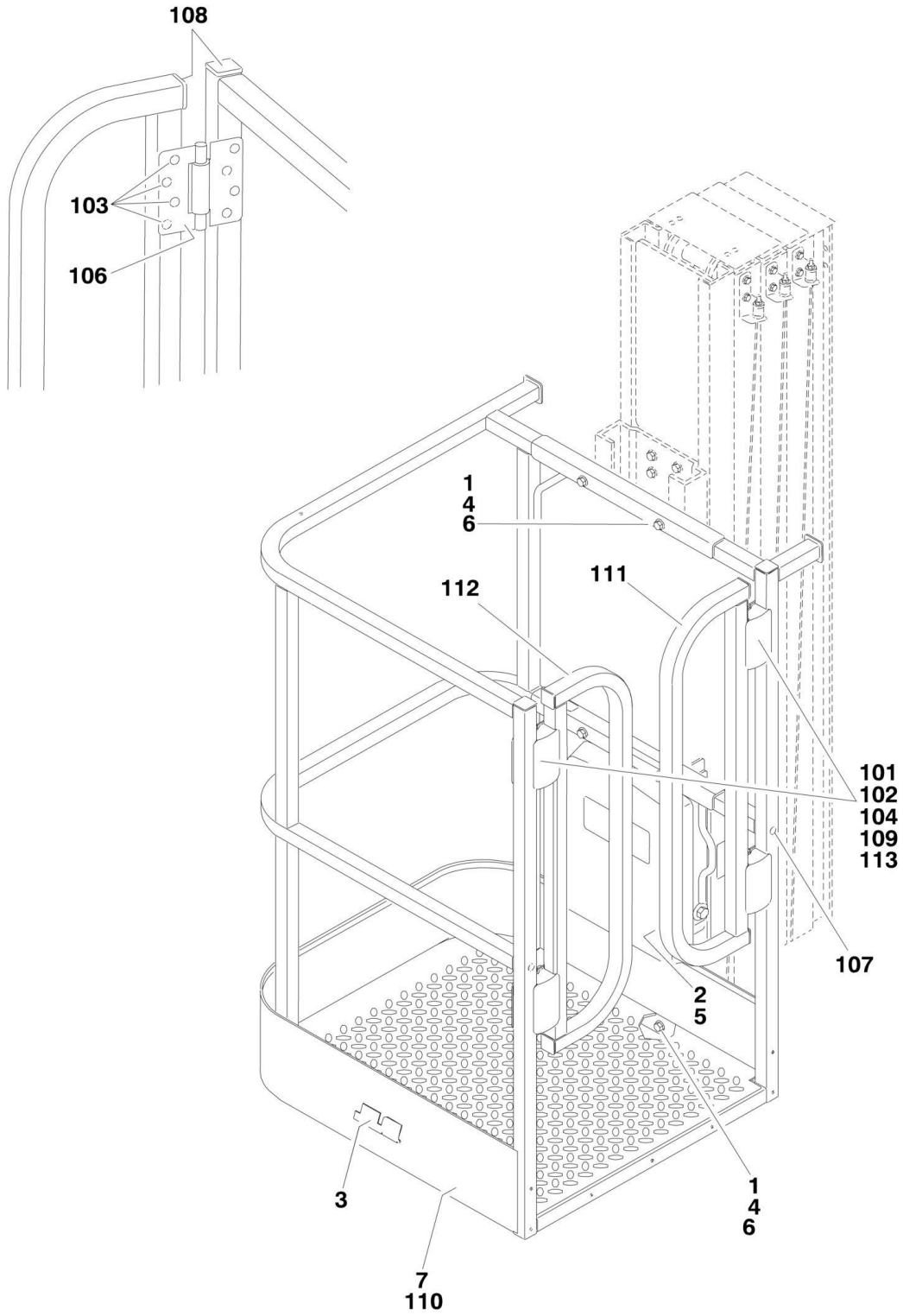

SECTION 4 - PLATFORM

FIGURE 4-2. PLATFORM (27IN/69CM X 23IN/58.5CM) WITH SWING GATE

ITEM	PART NUMBER	QTY	DESCRIPTION	REV
		Ref	Note: Right/Left Side Gate Entry determined by operator's position when facing push button controls.	
		Ref	PLATFORM INSTALLATION	
	1001125398	Ref	Platform with Left Side Gate Entry (Not Shown)	A
	1001111135	Ref	Platform with Right Side Gate Entry	A
1	0641622	6	Bolt 3/8in-16NC x 2-3/4in	
2	0860520	1	Box, Manual Storage	
3	1703681	2	Decal - JLG	
4	3311605	6	Locknut, 3/8in-16NC	
5	3820032	4	Rivet	
6	4711600	12	Flatwasher 3/8in Thin	
7		Ref	Platform Assembly Options (See Items 101-113 for Breakdown)	
7	1001125397	1	Platform with Left Hand Gate Entry (Not Shown)	
7	1001111134	1	Platform with Right Hand Gate Entry	
		Ref	PLATFORM ASSEMBLY	
	1001125397	Ref	Platform with Left Hand Gate Entry (Not Shown)	B
	1001111134	Ref	Platform with Right Hand Gate Entry	B
101	0100011	AR	Compound, Locking	
102	0641416	8	Bolt 1/4in-20NC x 2in	
103	2080040	16	Blind Fastener	
104	2080043	8	Rivnut	
106	2600294	4	Hinge, Self Closing	
107	3520028	2	Plug, Hole	
108	3520072	8	Cap-Plug	
109	4220309	4	Stop	
110		Ref	Platform Weldment Options:	
110	1001125396	1	Platform with Left Hand Gate Entry (use p/n 1001125397) (Not Shown)	
110	1001111133	1	Platform with Right Hand Gate Entry (use p/n 1001111134)	
111	2410024	1	Door Weldment (Closest to Mast) (use p/n 1001132792)	
112	2410024	1	Door Weldment (Furtherest from Mast) (use p/n 1001132793)	
113	4071095	AR	Shim, Hinge	
	1001141754	Ref	PLATFORM KIT (MODIFIES SIDE ENTRY TO REAR ENTRY) (OPTIONAL)	

SECTION 4 - PLATFORM

FIGURE 4-3. PLATFORM (26IN/66CM X 25IN/63.5CM) WITH SWING GATE

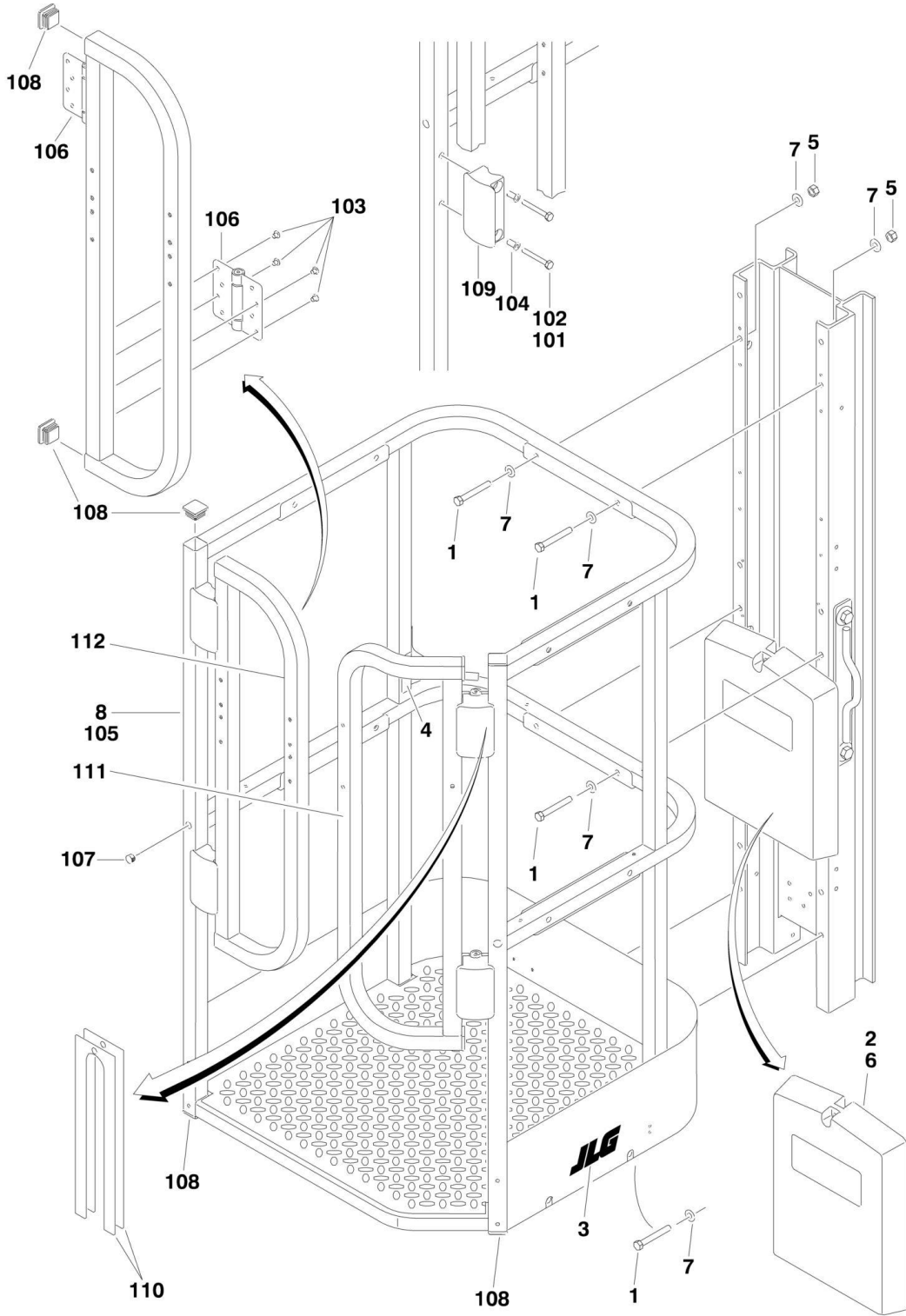

SECTION 4 - PLATFORM

FIGURE 4-3. PLATFORM (26IN/66CM X 25IN/63.5CM) WITH SWING GATE

ITEM	PART NUMBER	QTY	DESCRIPTION	REV
		Ref	Note: Right/Left Side Gate Entry determined by operator's position when facing push button controls.	
		Ref	PLATFORM INSTALLATION	
	1001141303	Ref	Platform with Rear Gate Entry	A
	1001134102	Ref	Platform with Left Side Gate Entry (Not Shown)	A
	1001141301	Ref	Platform with Right Side Gate Entry (Not Shown)	A
1	0641622	6	Bolt 3/8in-16NC x 2-3/4in	
2	0860520	1	Box, Manual Storage	
3	1703681	2	Decal - JLG	
4	1704277	2	Decal - Lanyard	
5	3311605	6	Locknut, 3/8in-16NC	
6	3820032	4	Rivet	
7	4711600	12	Flatwasher 3/8in Thin	
8	1001133771	1	Platform Assembly Options (See Items 101-112 for Breakdown)	
	1001133771	Ref	PLATFORM ASSEMBLY	A
101	0100011	AR	Compound, Locking	
102	0641416	8	Bolt 1/4in-20NC x 2in	
103	2080040	16	Blind Fastener	
104	2080043	8	Rivnut	
105	1001133770	1	Platform Weldment (use p/n 1001133771)	
106	2600294	4	Hinge, Self Closing	
107	3520028	2	Plug, Hole	
108	3520072	8	Cap-Plug	
109	4220309	4	Stop	
110	4071095	AR	Shim, Hinge	
111	1001139325	1	Gate, Right	
112	1001132793	1	Gate, Left	

SECTION 4 - PLATFORM

FIGURE 4-4. PLATFORM OPTIONS

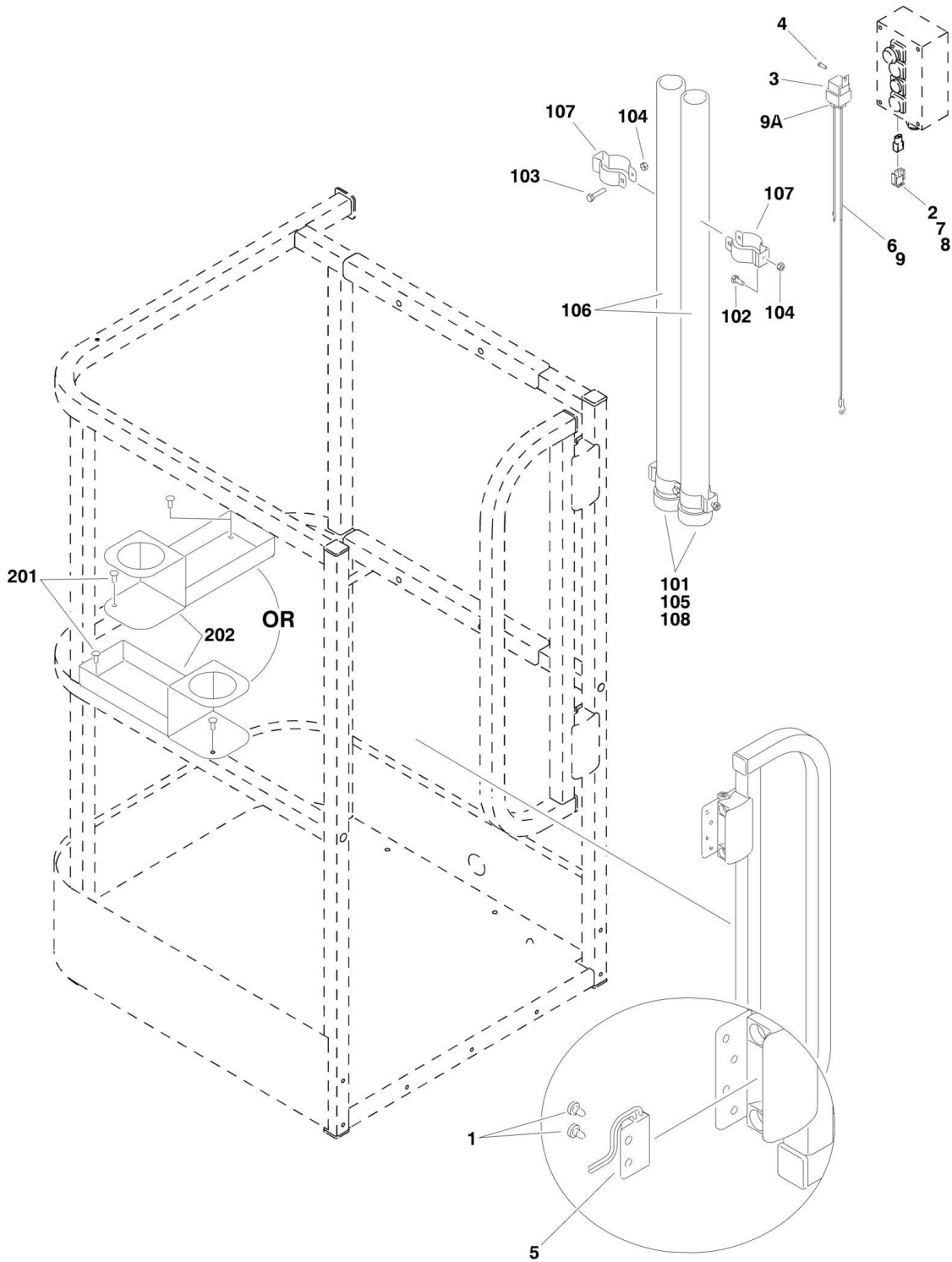

SECTION 4 - PLATFORM

FIGURE 4-4. PLATFORM OPTIONS

ITEM	PART NUMBER	QTY	DESCRIPTION	REV
	1001111597	Ref	GATE INTERLOCK INSTALLATION (OPTIONAL)	A
		Ref	Note: For Corning Spec SN 0130016095 to Present See PLATFORM GATE INTERLOCK INSTALLATION for Breakdown.	
1	0751003	4	Screw #10	
2	2820035	3 ft/.9m	Insulation	
3	3740049	1	Relay	
4	3820032	1	Rivet	
5	4360573	2	Switch, Proximity	
5	4460267	2	Pin, Male	
6	4460035	2	Terminal, Butt	
7	4460267	2	Pin, Male	
8	4460320	2	Plug, Male - 2 Position	
9	1001111751	1	Harness, Gate Switch	
9	4460268	1	Socket, Female	
9A	4460471	1	Plug, Male - 2 Position	
9A	4460320	4	Terminal, Slip-On	
	1001111660	Ref	PVC CARRIERS INSTALLATION (OPTIONAL)	B
101	0100090	AR	Adhesive	
102	0641405	2	Bolt 1/4in-20NC x 5/8in	
103	0641410	2	Bolt 1/4in-20NC x 1-1/4in	
104	3311405	4	Locknut 1/4in-20NC	
105	3340849	3/4in/1.8cm	Pad, Neoprene	
106	3460311	2	Pipe, PVC	
107	1001111658	4	Clamp	
108	1001111739	2	Cap, PVC	
	1001111659	Ref	TRAY INSTALLATION (OPTIONAL)	B
201	2080040	2	Fastener, Huck	
202	4845929	1	Tray Weldment	

SECTION 4 - PLATFORM

FIGURE 4-5. PLATFORM GATE INTERLOCK INSTALLATION

27IN/69CM X 23IN/58.5CM PLATFORMS

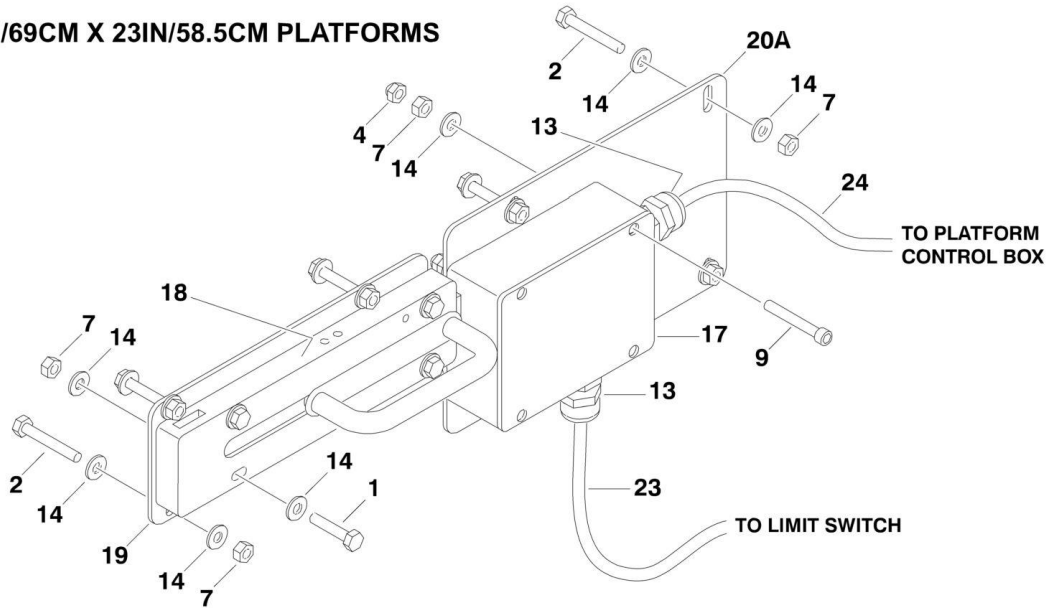

26IN/66CM X 25IN/63.5CM PLATFORMS

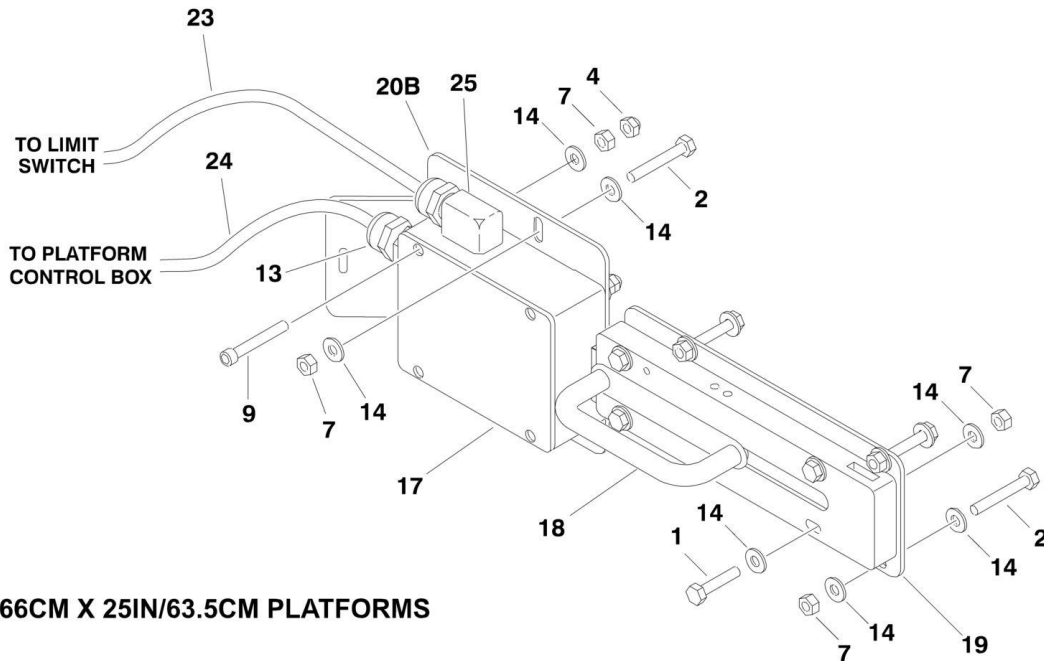

SECTION 4 - PLATFORM

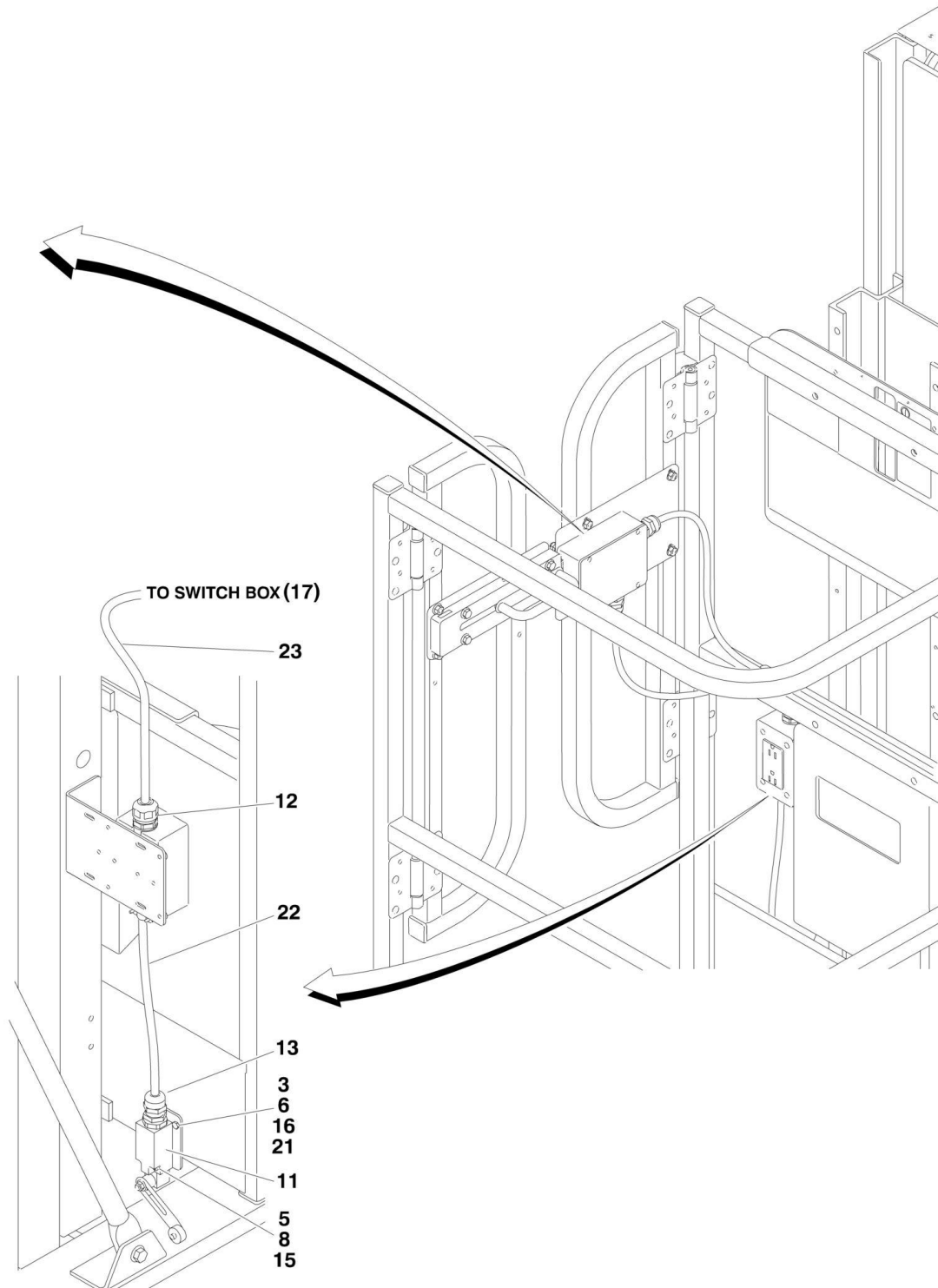

VIEW SHOWN REVERSED FOR CLARITY.

SECTION 4 - PLATFORM

FIGURE 4-5. PLATFORM GATE INTERLOCK INSTALLATION

ITEM	PART NUMBER	QTY	DESCRIPTION	REV
		Ref	GATE INTERLOCK INSTALLATION (CORNING SPEC) (SN 0130016095 to Present)	
	1001128990	Ref	27in/69cm x 23in/58.5cm Platforms	A
	1001141536	Ref	26in/66cm x 25in/63.5cm Platforms	A
		Ref	Note: For Corning Spec Prior to SN 0130016095 and all machines See PLATFORM OPTIONS for Breakdown.	
1	0641410	4	Bolt 1/4in-20NC x 1-1/4in	
2	0641414	AR	Bolt 1/4in-20NC x 1-3/4in	
3	0721004	2	Screw #10-24NC x 1/2in	
4	3300430	4	Nut, Acorn 1/4in-20NC	
5	3310805	2	Locknut #8-32NC	
6	3311005	2	Locknut #10-24NC	
7	3311405	AR	Locknut 1/4in-20NC	
8	3930820	2	Capscrew #8-32NC x 1-1/4in	
9	3931428	4	Capscrew 1/4in-20NC x 1-3/4in	
10	4240033	AR	Tie-Strap (Not Shown)	
11	4360579	1	Switch, Limit	
12	4460662	1	Connector, Strain Relief	
13	4460968	AR	Connector, Strain Relief	
14	4711400	AR	Flatwasher 1/4in Thin	
15	4750800	2	Flatwasher #8 Regular	
16	4751000	2	Flatwasher #10 Regular	
17	1001130481	1	Switch, Solenoid Lacing	
18	1001130482	1	Latch, Slide Bolt	
19	1001132308	1	Plate, Latch	
20		Ref	Plate, Gate Switch Options:	
20A	1001132309	1	27in/69cm x 23in/58.5cm Platforms	
20B	1001141114	1	26in/66cm x 25in/63.5cm Platforms	
21	1001132753	1	Plate, Limit Switch	
22	1001133131	1	Harness, Gate Limit Switch	B
23	1001133132	1	Harness, Gate Switch	C
24	1001133134	1	Harness, Lift Cutout	B
24	4460267	2	Pin, Male	
24	4460320	2	Plug, Male - 2 Position	
25	1001103471	1	Connector, 90 Strain Relief	

SECTION 5 - CYLINDER

SECTION 5 - CYLINDER

FIGURE 5-1. LIFT CYLINDER ASSEMBLY (ALL MACHINES) (Excluding SN 0130005748)

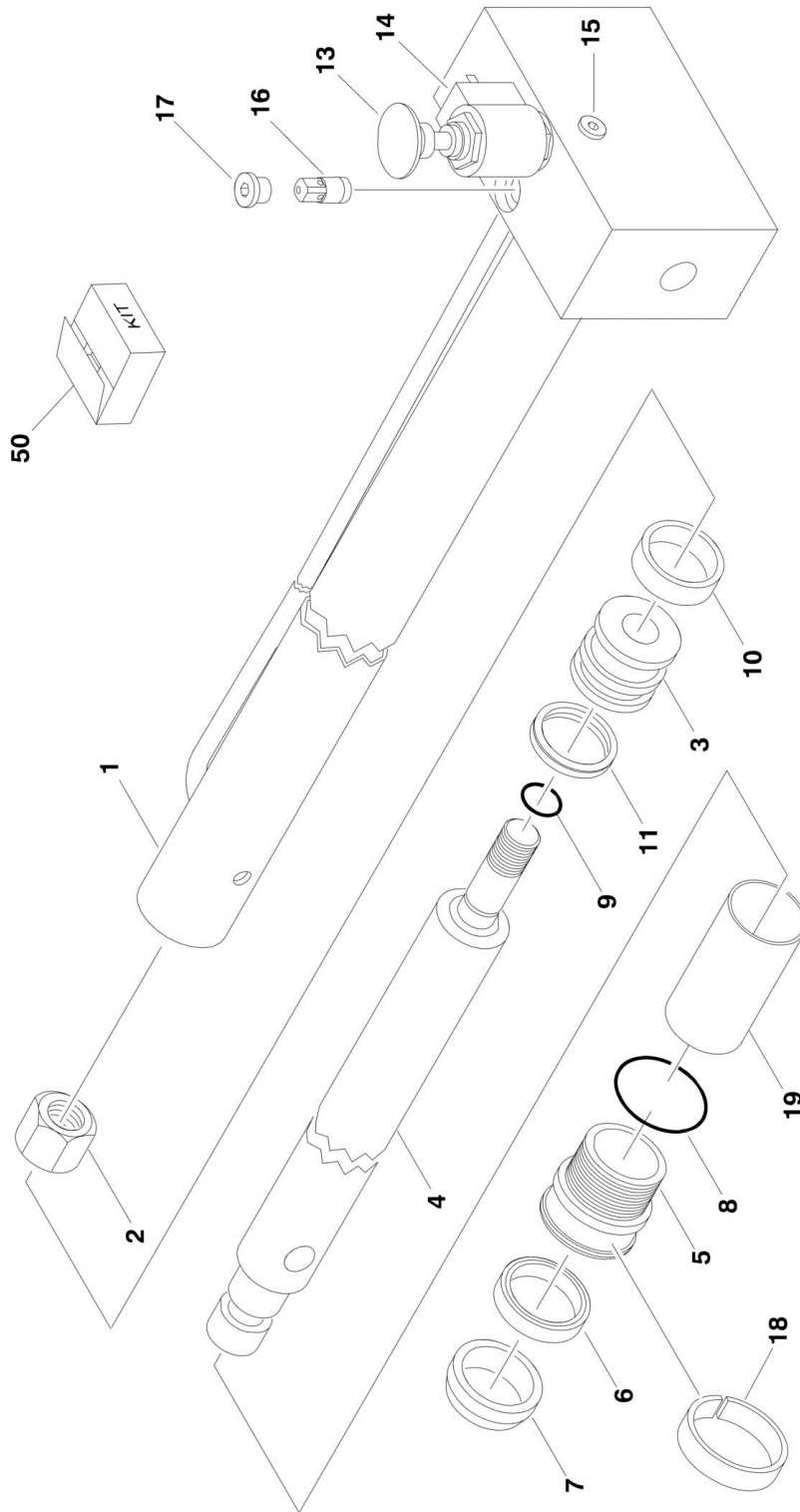

SECTION 5 - CYLINDER

FIGURE 5-1. LIFT CYLINDER ASSEMBLY (ALL MACHINES) (Excluding SN 0130005748)

ITEM	PART NUMBER	QTY	DESCRIPTION	REV
		Ref	LIFT CYLINDER ASSEMBLY	
	1001099734	Ref	Lift Cylinder Assembly 15BD	C
	1001100058	Ref	Lift Cylinder Assembly 19BD	B
1	70002092	1	Barrel	
2	7023391	1	Nut	
3	7023392	1	Piston	
4	70002093	1	Rod	
5	70002094	1	Head	
6	See Note	NSS	Seal, Rod (Note: Use Item 50)	
7	See Note	NSS	Rod Wiper (Note: Use Item 50)	
8	See Note	NSS	O-Ring (Note: Use Item 50)	
9	See Note	NSS	O-Ring (Note: Use Item 50)	
10	See Note	NSS	Seal (Note: Use Item 50)	
11	See Note	NSS	Seal, Piston (Note: Use Item 50)	
13	7023399	1	Knob - Red	
14	7023396	1	Poppet, Solenoid Valve	
14	7012998	1	Seal Kit - 7023396 Valve	
14	7023993	1	Coil	
15	See Note	1	Plug (Note: Not Available - Purchase Locally)	
16	70002095	1	Flow Control Valve	
17	See Note	1	Plug (Note: Not Available - Purchase Locally)	
18	70002096	1	Ring, Wear	
19	70002429	1	Bushing	
50	7023395	1	Seal Kit (Includes Items 6-11)	

SECTION 5 - CYLINDER

FIGURE 5-2. LIFT CYLINDER ASSEMBLY (Including SN 0130005748)

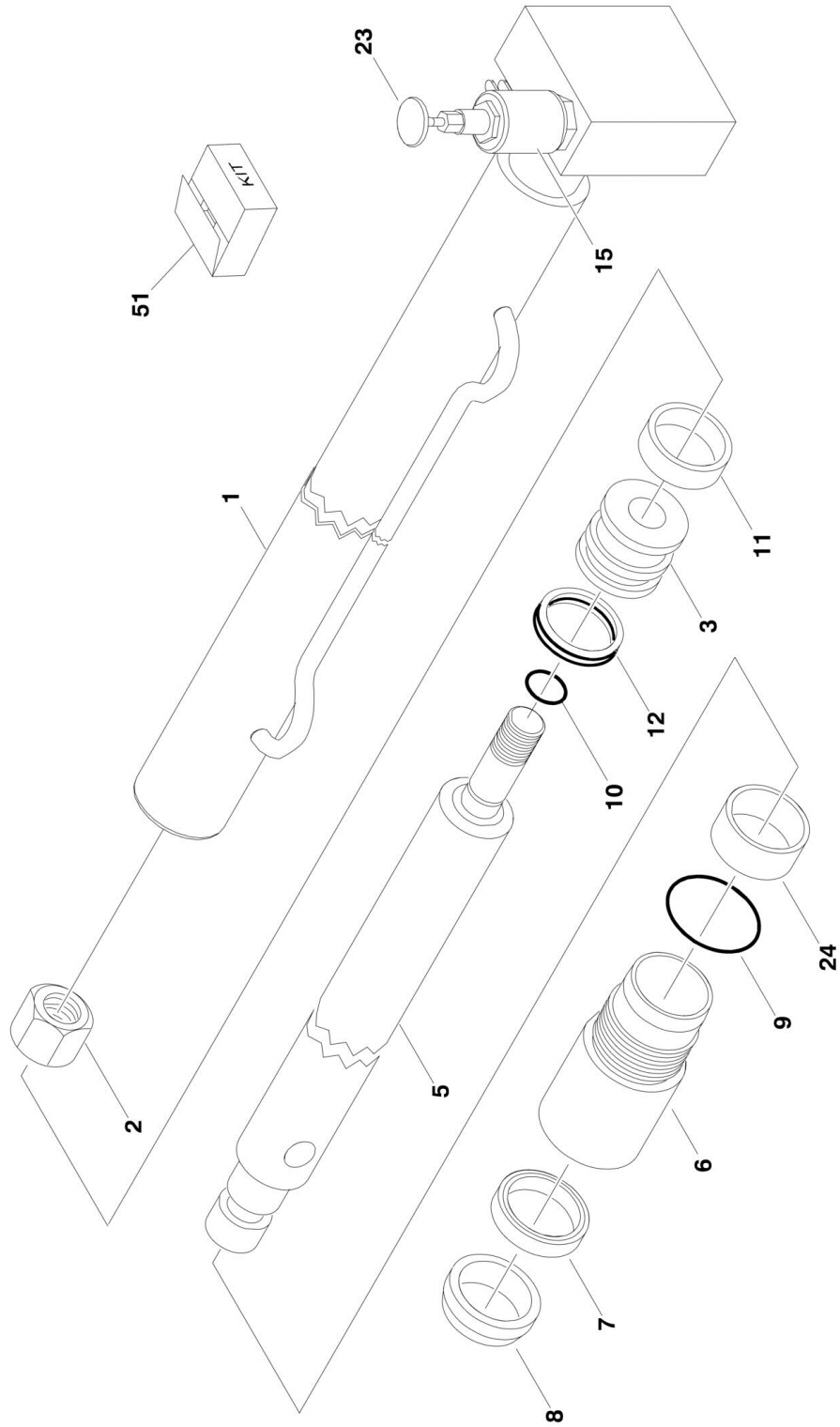

SECTION 5 - CYLINDER

FIGURE 5-2. LIFT CYLINDER ASSEMBLY (Including SN 0130005748)

ITEM	PART NUMBER	QTY	DESCRIPTION	REV
	1684088	Ref	LIFT CYLINDER ASSEMBLY	H
1	1684088	1	Barrel	
2	7023391	1	Nut	
3	7023392	1	Piston	
5	7023393	1	Rod	
6	7023394	1	Head	
7	See Note	NSS	Seal, Rod (Note: Use Item 51)	
8	See Note	NSS	Rod Wiper (Note: Use Item 51)	
9	See Note	NSS	O-Ring (Note: Use Item 51)	
10	See Note	NSS	O-Ring (Note: Use Item 51)	
11	See Note	NSS	Ring, Wear (Note: Use Item 51)	
12	See Note	NSS	Seal, Piston (Note: Use Item 51)	
15	7023396	1	Poppet, Solenoid Valve	
15	7012998	1	Seal Kit - 7023396 Valve	
15	7023993	1	Coil	
16	7023397	1	Spring (Not Shown)	
17	7023398	1	Control Valve (Not Shown)	
23	7023399	1	Knob - Red	
24	Not Required	0	Spacer	
51	7023395	1	Seal Kit (Includes Items 7-12)	

SECTION 6 - HYDRAULIC

SECTION 6 - HYDRAULIC

FIGURE 6-1. HYDRAULIC DIAGRAM

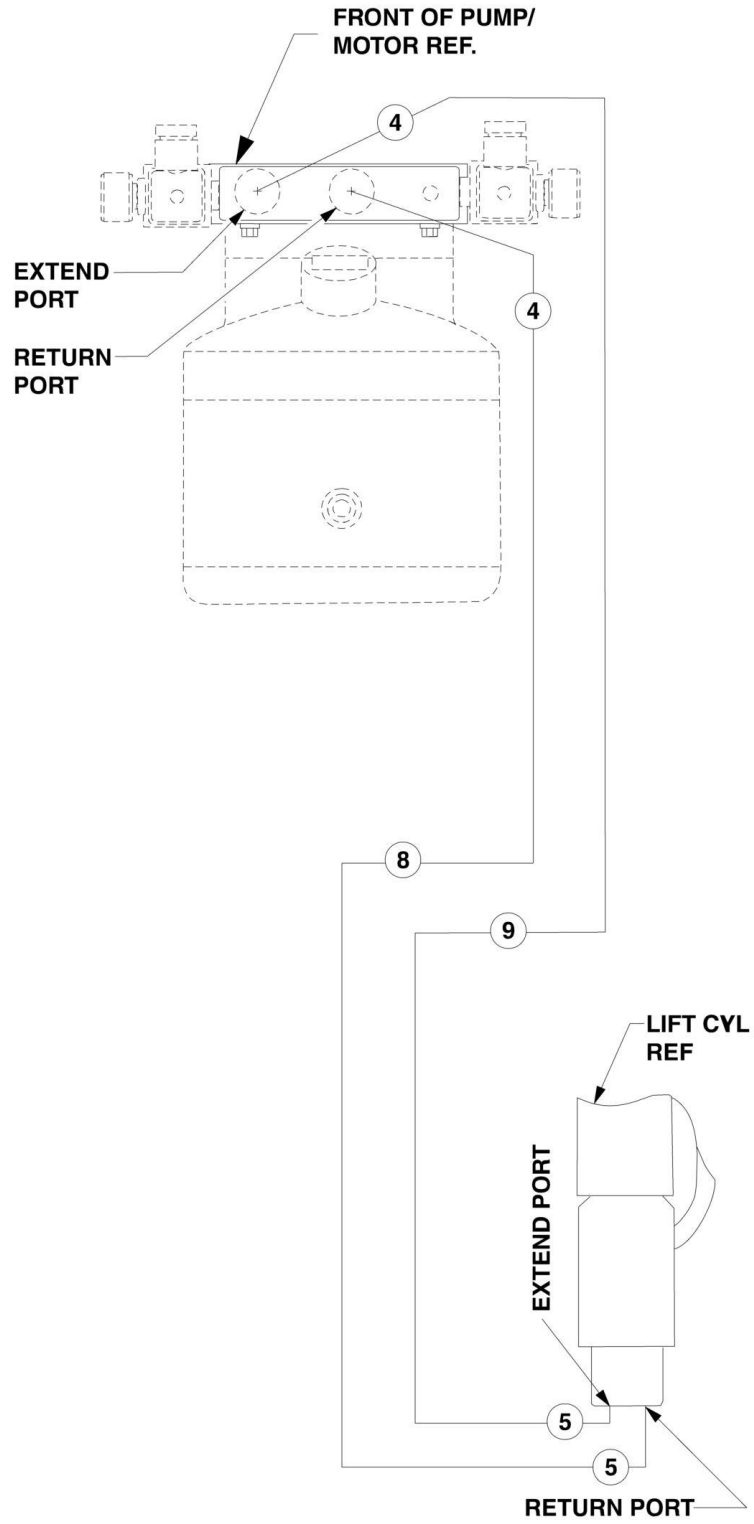

SECTION 6 - HYDRAULIC

FIGURE 6-1. HYDRAULIC DIAGRAM

ITEM	PART NUMBER	QTY	DESCRIPTION	REV
		Ref	Note: Right/Left Side Gate Entry determined by operator's position when facing push button controls.	
		Ref	HYDRAULIC DIAGRAM OPTIONS:	
	0275939	Ref	All Machines with Gullwing or Right Side Entry Platforms (Excluding SN 0130005748)	A
	10011126224	Ref	All Machines with Left Side Entry Platforms (Not Shown) (Excluding SN 0130005748)	A
	2915246	Ref	Hydraulic Diagram (Including SN 0130005748)	2
4	2220473	2	Fitting	
5		Ref	Fitting Options:	
5	2220473	2	Fitting All Machines (Excluding SN 0130005748)	
5	2220603	2	Fitting (Including SN 0130005748)	
8		Ref	Tube, Return Options:	
8	1001100544	1	Tube, Return All Machines (Excluding SN 0130005748)	
8	4569478	1	Tube, Return (Including SN 0130005748)	
9		Ref	Tube, Extend Options:	
9	1001100545	1	Tube, Extend All Machines (Excluding SN 0130005748)	
9	4569479	1	Tube, Extend (Including SN 0130005748)	

SECTION 7 - ELECTRICAL

SECTION 7 - ELECTRICAL

FIGURE 7-1. ELECTRICAL SCHEMATIC - 120VAC, 60HZ

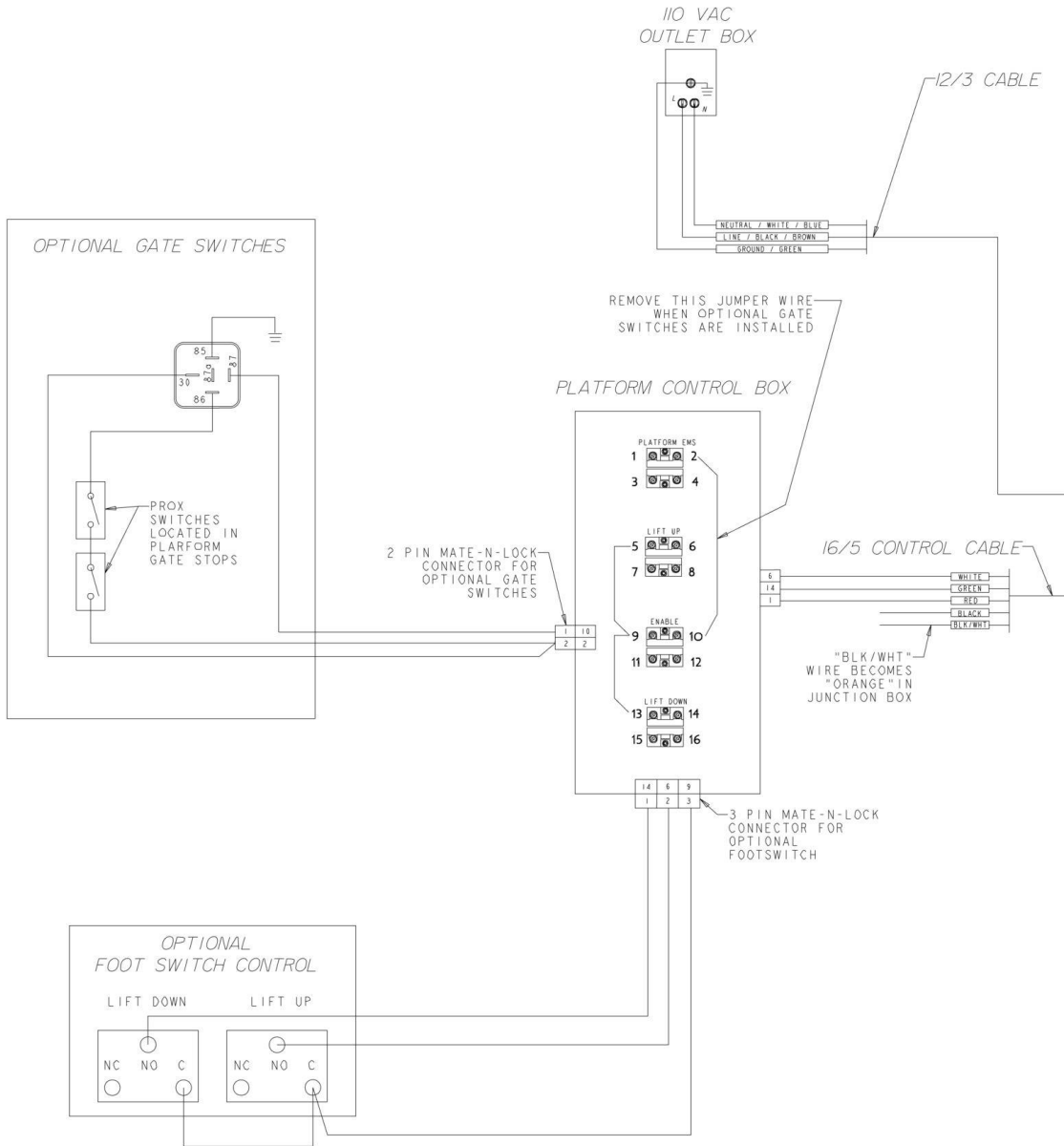

SECTION 7 - ELECTRICAL

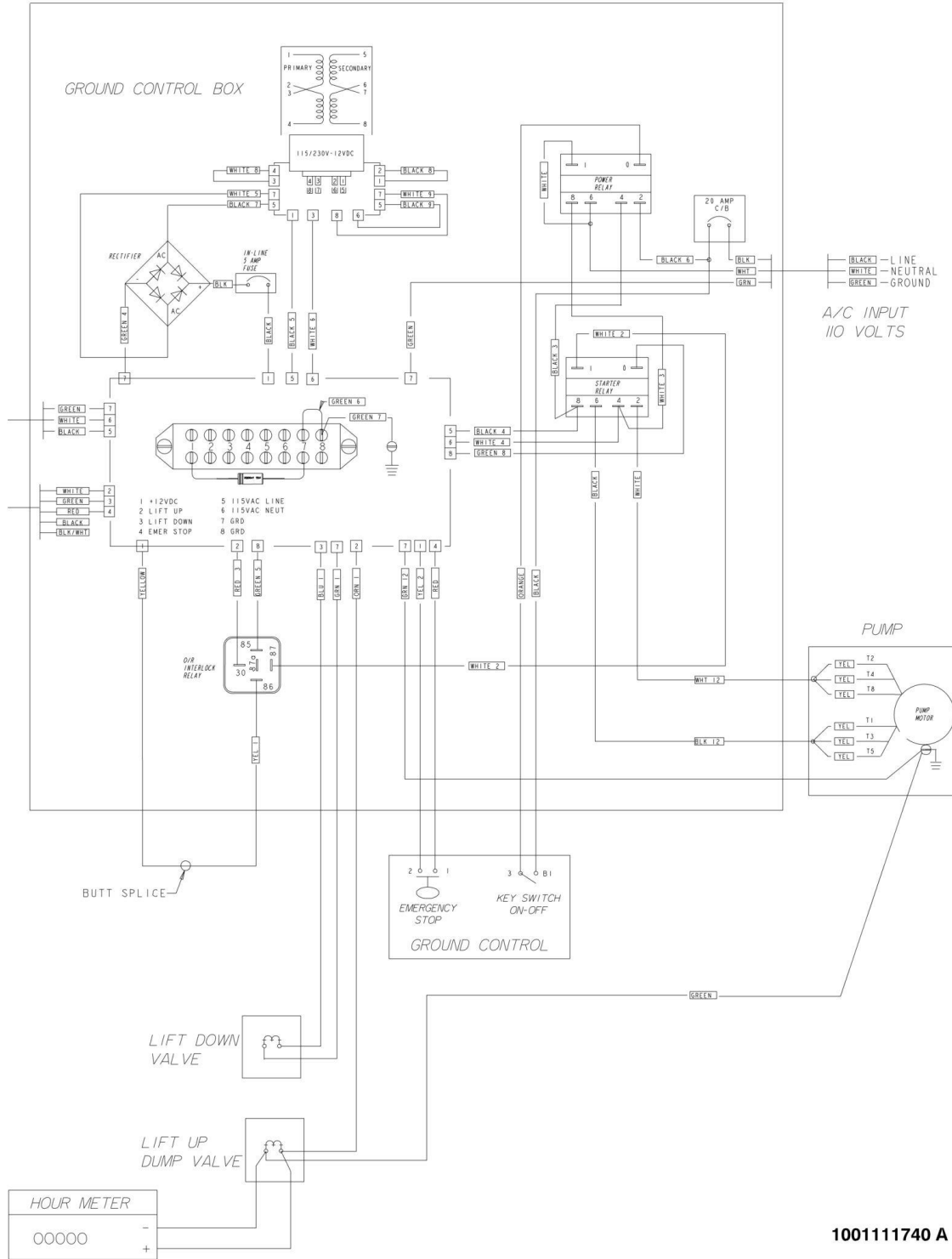

100111740 A

SECTION 7 - ELECTRICAL

FIGURE 7-2. ELECTRICAL SCHEMATIC - 120VAC, 60HZ (CORNING SPEC)

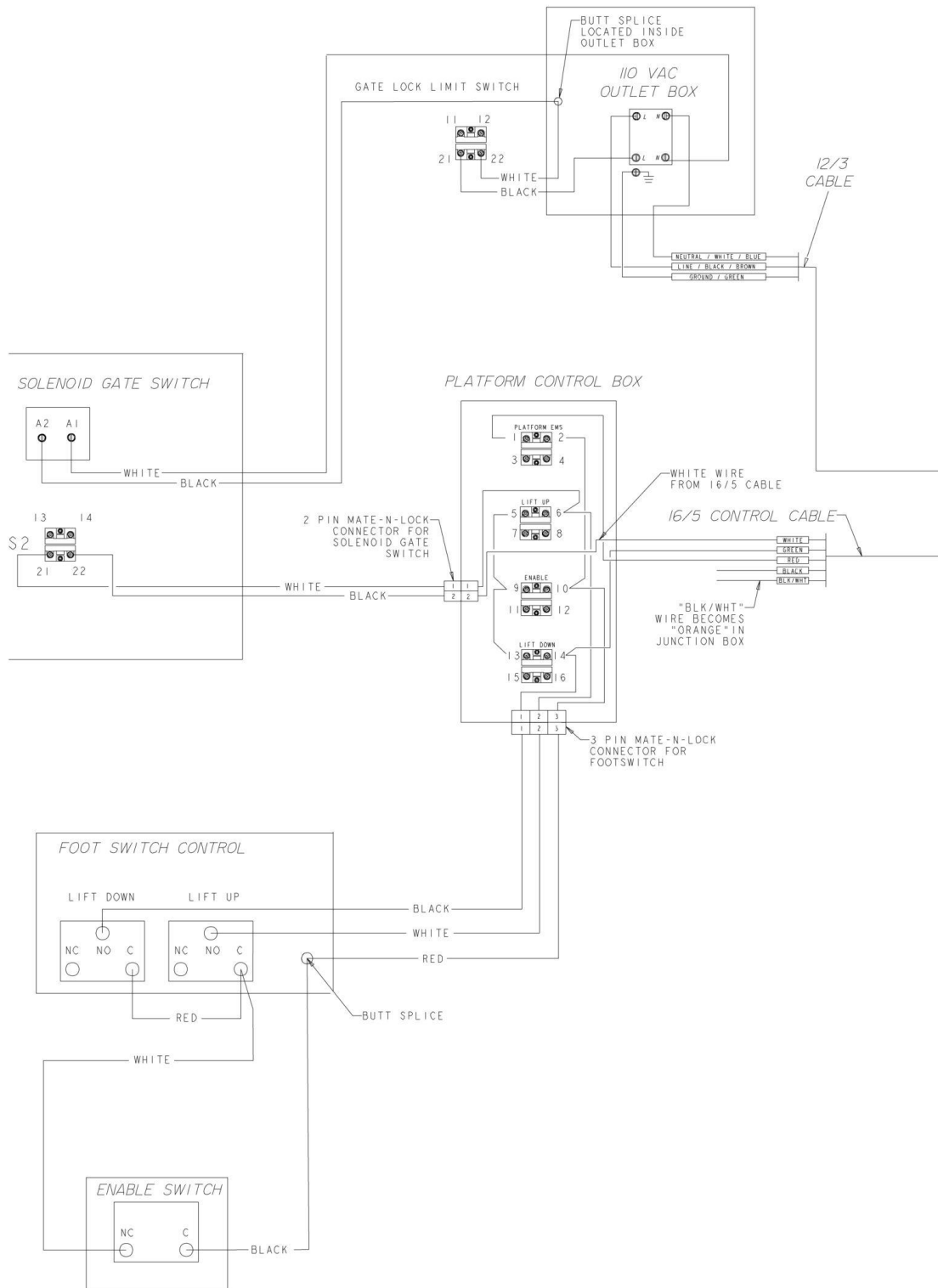

SECTION 7 - ELECTRICAL

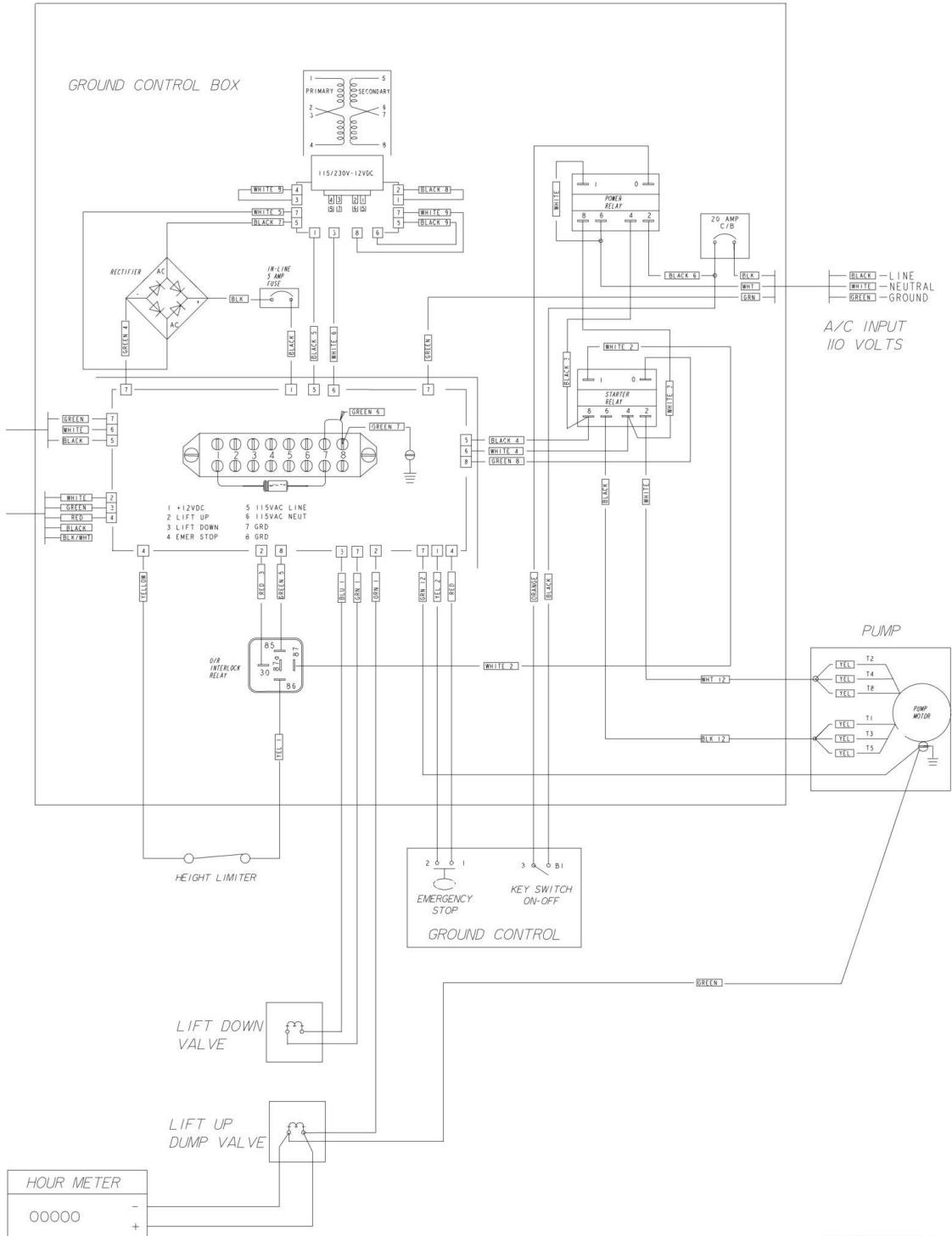

1001133268 B
1001167246 A

SECTION 7 - ELECTRICAL

FIGURE 7-3. ELECTRICAL SCHEMATIC - 120VAC, 50-60HZ (CORNING SPEC)

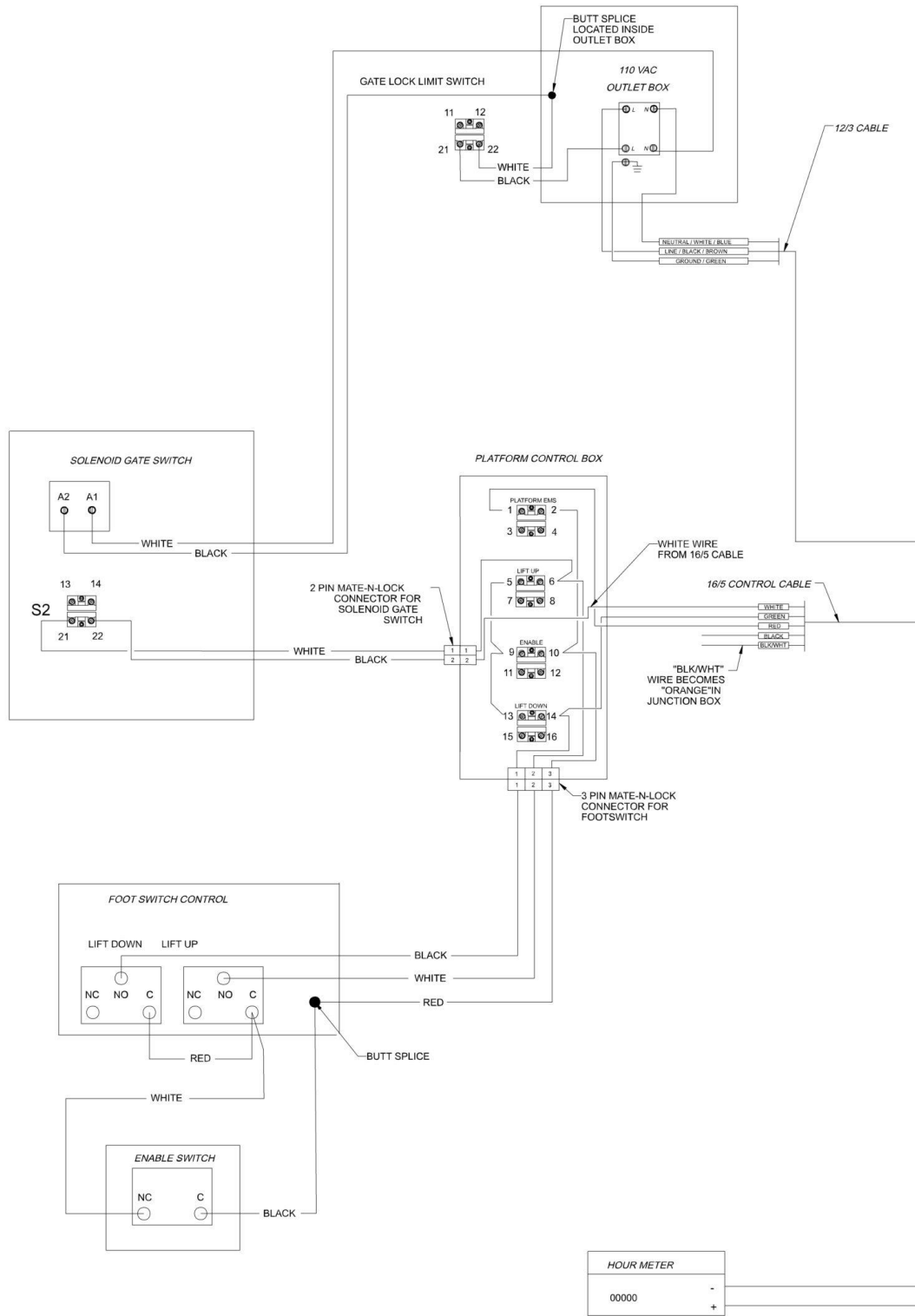

SECTION 7 - ELECTRICAL

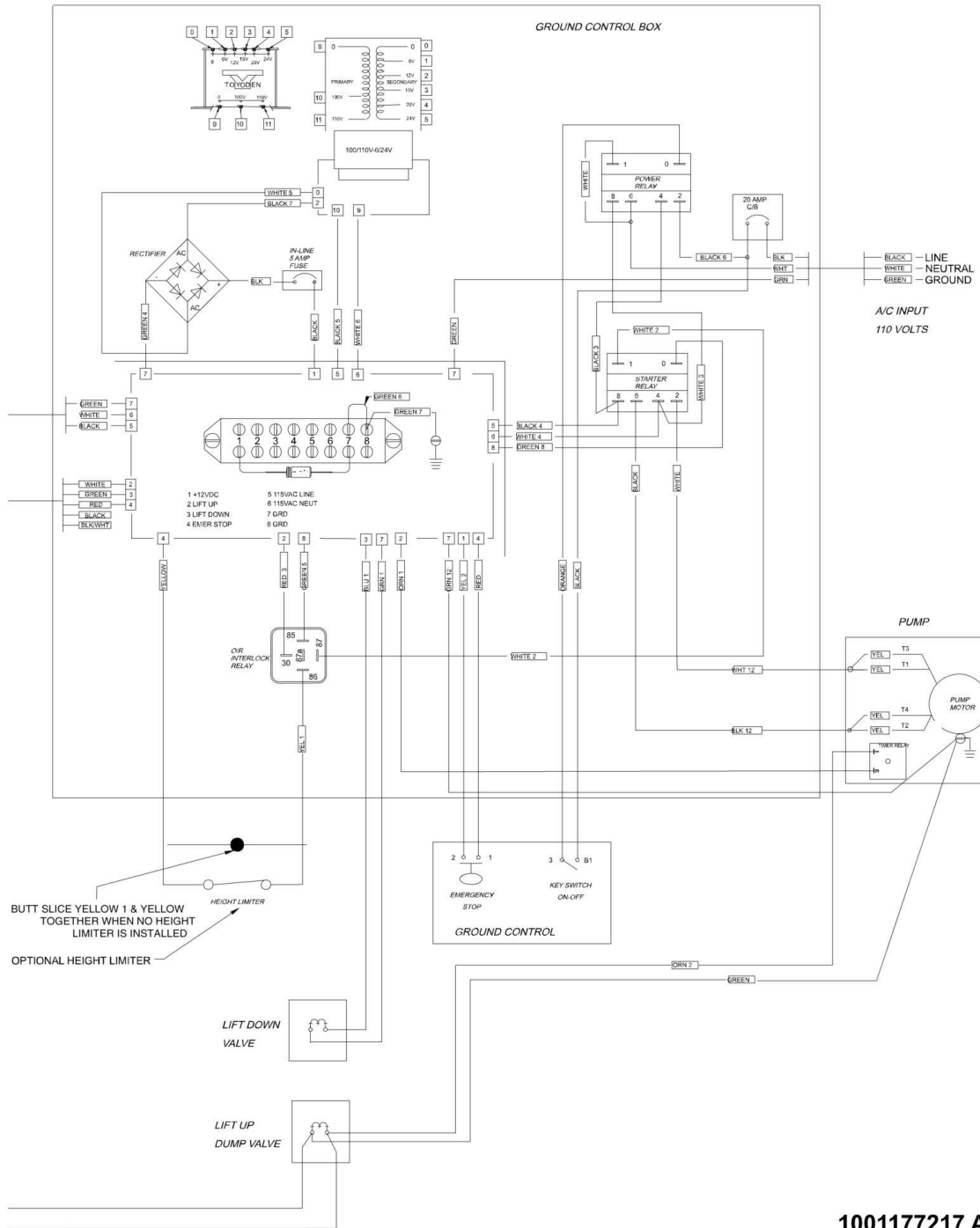

SECTION 7 - ELECTRICAL

FIGURE 7-4. ELECTRICAL SCHEMATIC - 220VAC, 50-60HZ (CORNING SPEC)

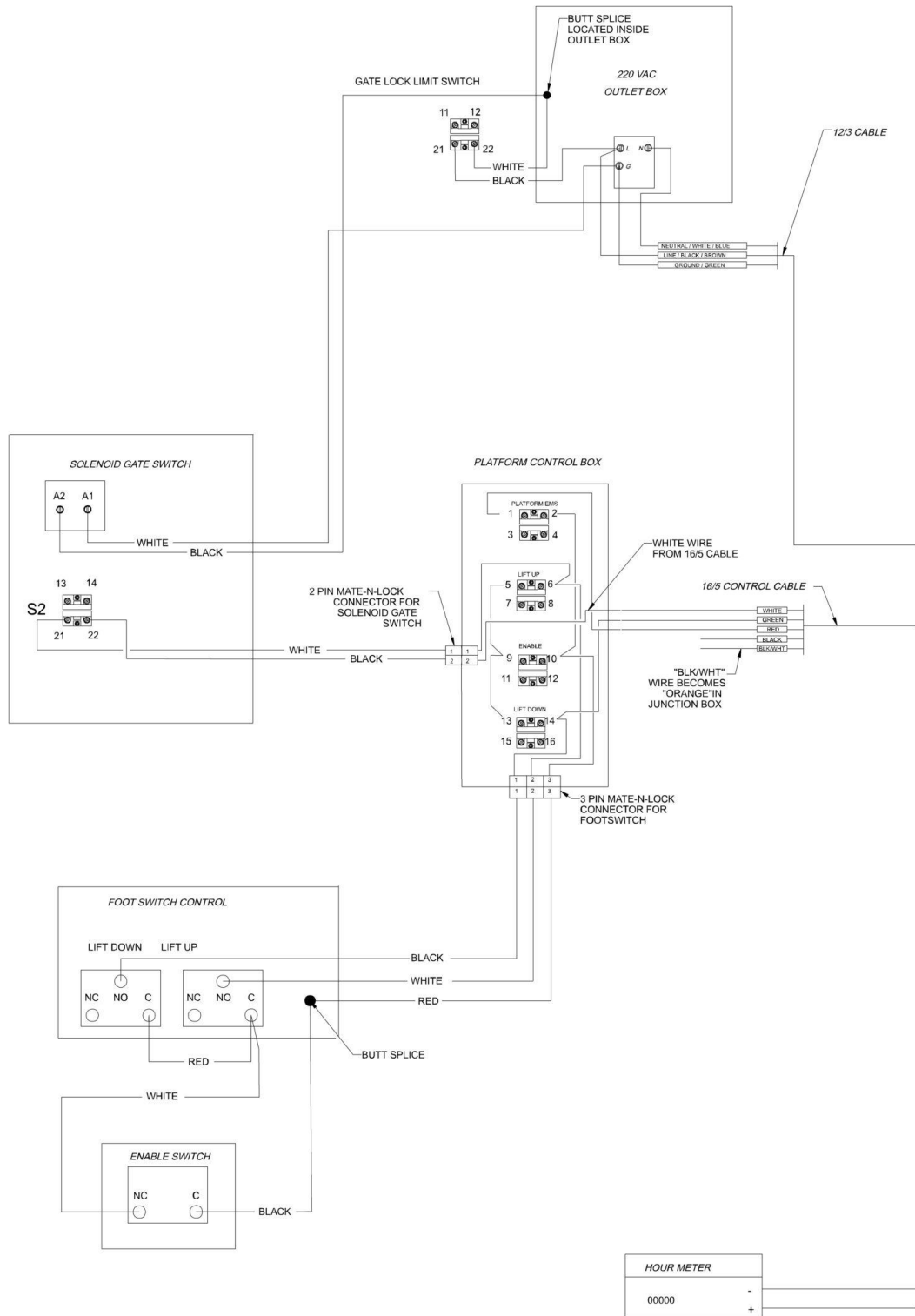

SECTION 7 - ELECTRICAL

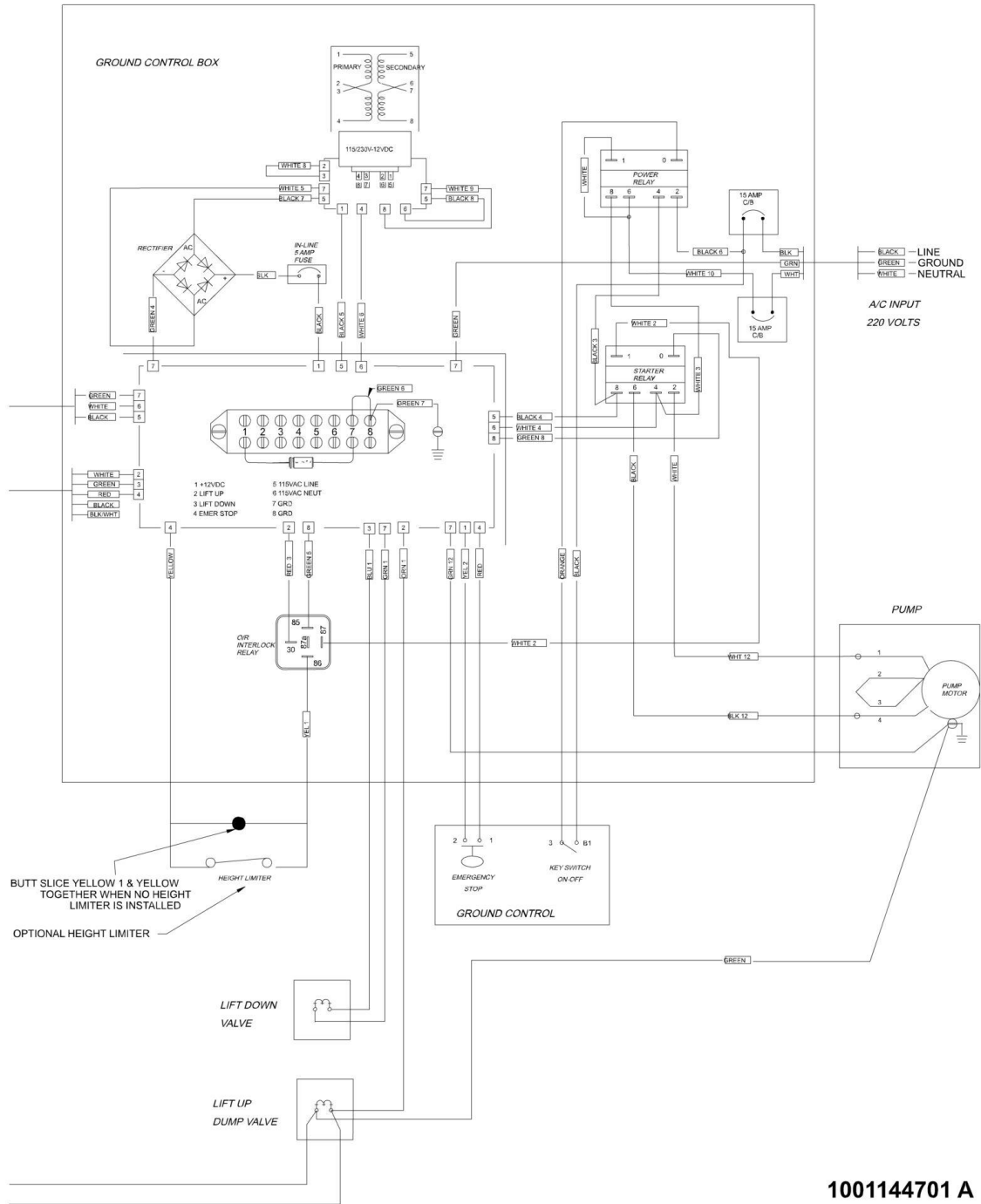

SECTION 8 - DECALS

SECTION 8 - DECALS

FIGURE 8-1. DECAL INSTALLATION

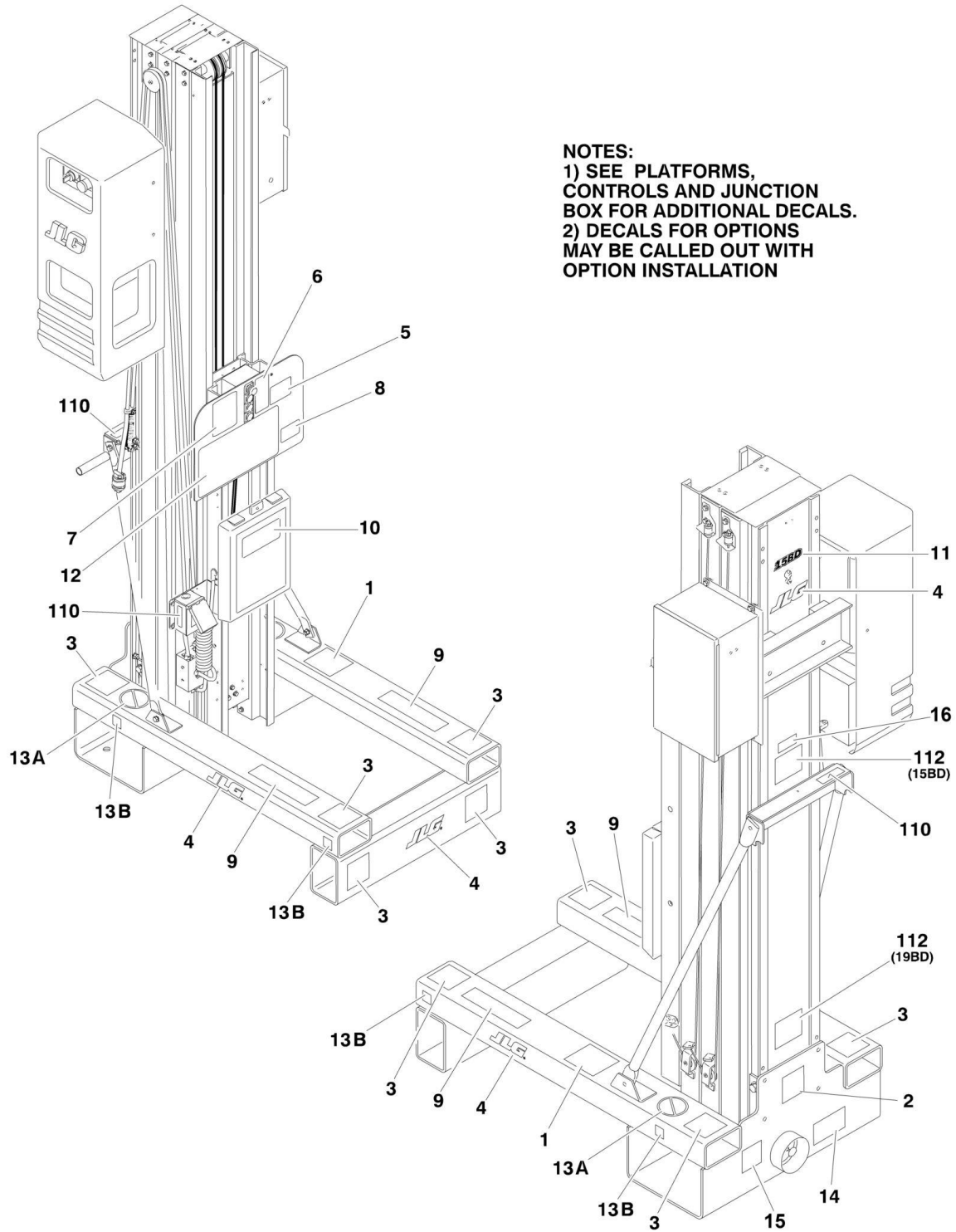

NOTES:
 1) SEE PLATFORMS, CONTROLS AND JUNCTION BOX FOR ADDITIONAL DECALS.
 2) DECALS FOR OPTIONS MAY BE CALLED OUT WITH OPTION INSTALLATION

SECTION 8 - DECALS

FIGURE 8-1. DECAL INSTALLATION

ITEM	PART NUMBER	QTY	DESCRIPTION	REV
		Ref	DECAL INSTALLATION	
	0272159	Ref	Decal Installation 15BD	F
	1001128987	Ref	Decal Installation 19BD	D
1		Ref	Decal - Patent Options:	
1	1700584	1	Decal - Patent (Prior to SN 0130016815)	
1	1001131273	1	Decal - Patent (SN 0130016815 to Present)	
2	See Note	1	Decal - Bar Code Only (Note: Available for Purchase)	
3	1703073	6	Decal - Fork Pockets	
4	1703681	4	Decal - JLG	
5	1703779	1	Decal - USA	
6	1705633	1	Decal - Function Controls	
7		Ref	Decal - Electrical Hazard Options:	
7	1703781	1	Decal - Electrical Hazard (Prior to SN 0130017911)	
7	1001141434	1	Decal - Electrical Hazard (SN 0130017911 to Present)	
8	1705635	1	Decal - Maximum Capacity	
9	1705634	2	Decal - Crushing Hazard	
10		Ref	Decal - Manual Options:	
10	1703788	1	Decal - Manual 15BD	
10	1701509	1	Decal - Manual 19BD	
11		Ref	Decal - Model Designation	
11	1705215	1	Decal - Model Designation 15BD	
11	1001130094	1	Decal - Model Designation 19BD	
12	1705220	1	Decal - Warning	
13A	1703072	2	Decal - No Forklift (Prior to SN 0130021994)	
13B	1001175996	4	Decal - No Forklift (SN 0130021994 to Present)	
14	1705636	1	Decal - Manual Descent	
15	1001223055	1	Decal - Yearly Inspection	
16	1001228370	1	Decal - ICES	
	0010586	Ref	DECALS INSTALLATION (SPECIAL)	8
110	0258842	Ref	Voltage Decal Installation	A
110	0258842	1	Decal - 120V-60Hz (use p/n 3251243)	
112	See Note	1	Nameplate - Serial Number (Note: Available for Purchase)	

SECTION 9 - RECOMMENDED SERVICE PARTS STOCK

SECTION 9 - RECOMMENDED SERVICE PARTS STOCK

SECTION 9 - RECOMMENDED SERVICE PARTS STOCK

FIGURE 9-1. 15BD STANDARD PARTS

ITEM	PART NUMBER	QTY	DESCRIPTION	REV
	Note	Ref	Note: The following list will service fleets of machines (built to current production per date on the front cover) with emergency repair parts which can be installed in the field. Parts from the list should be replaced when inventory is depleted to keep service parts stock supplied. For further information, contact your JLG dealer or the JLG Industries Parts Department	
		Ref	STANDARD PARTS	
	7020078	1	Switch, Push Button (Red)	
	4360467	1	Switch, Key	
	2860030	1	Key Replacement	
	7026165	1	Filler	
	70000643	1	Coil	
	70001025	1	Cap/Breather	
	3740049	1	Relay	
	3740093	1	Relay (115V)	
	3740094	1	Relay	
	4360161	2	Breaker, Circuit - 20 Amp (115V)	
	4360070	2	Breaker, Circuit - 15 Amp (230V)	
	2400006	2	Fuse 5-Amp	
	7020088	1	Switch, Push Button (White)	
	7020089	1	Switch, Push Button (Green)	
	3990010	2	Diode 6 Amp	
	7023993	1	Coil	

SECTION 9 - RECOMMENDED SERVICE PARTS STOCK

FIGURE 9-2. 15BD VARIABLE PARTS

ITEM	PART NUMBER	QTY	DESCRIPTION	REV
	Note	Ref	Note: The following list will service fleets of machines (built to current production per date on the front cover) with emergency repair parts which can be installed in the field. Parts from the list should be replaced when inventory is depleted to keep service parts stock supplied. For further information, contact your JLG dealer or the JLG Industries Parts Department	
		Ref	VARIABLE PARTS	
	3740105	1	Relay (Machines with 230V, 50-60Hz Junction Box)	
	4360384	1	Footswitch (Machines with Foot Controls)	
	1001129307	1	Footswitch (Machines with Foot Controls)	
	2940074	1	Latch (Machines with Gullwing Gate)	
	4360579	1	Switch, Limit (Corning Spec) (SN 0130016095 to Present)	
	1001130481	1	Switch (Corning Spec) (SN 0130016095 to Present)	
	3740049	1	Relay (Machines with Gate Interlock)	
	1001130482	1	Latch, Slide Bolt (Corning Spec) (SN 0130016095 to Present)	

SECTION 10 - SPECIAL OPTIONS

SECTION 10 - SPECIAL OPTIONS

FIGURE 10-1. SPECIAL OPTIONS

ITEM	PART NUMBER	QTY	DESCRIPTION	REV
	Note	Ref	Note: This list is to accommodate machines ordered with special equipment. Options may not be applicable to all models. For more specific parts information contact JLG Parts Department.	
	1580035	Ref	CONTAINER, SHIPPING SKID	
		Ref	ELECTRICAL CONNECTOR KITS	
	1001148902	Ref	Amp/Tyco Electrical Connector Kit	
	1001148903	Ref	Deutsch DT Electrical Connector Kit	
	1001148904	Ref	Deutsch HD Electrical Connector Kit	
	1001148905	Ref	Packard Electrical Connector Kit	
	1001233717	Ref	Sheaves Kit (19BD)	
	1001148906	Ref	Various Electrical Connectors Kit	
		Ref	SPECIAL TOOLS:	
	7002821	1	Crimper (For Wire to Pin/Socket Connections)	
	7002823	1	Extractor (For Removal of Pin/Socket Connectors)	
	4460467	1	Extractor 16-18 Gauge (For Wire to Pin/Socket from Deutsch Connectors)	
	4460510	1	Extractor 12-14 Gauge (For Wire to Pin/Socket from Deutsch Connectors)	
	7016654	1	Screwdriver, Magnetic	
	7004275	1	Seal Tool - 1in	
	7004276	1	Seal Tool - 1-1/2in	
	7002826	1	Seal Tool 2in	
	8896941	1	Stripper, Wire	

PART NUMBER INDEX

PART NUMBER INDEX

0010586.....81	0861731 28, 32, 36	1001132981 45	1701509.....81
0100011 15, 16, 27, 31, 35, 39, 43, 45, 51, 53	0902047 39, 43	1001133131 58	1702102.....23
0100062.....40, 41, 44, 45	0902422 39, 43	1001133132 58	1702103.....23
0100090.....55	0902423 39, 43	1001133134 58	1702120.....23
0256559.....41	0902424 43	1001133135 32, 35	1702365.....23
0258475.....49	0902431 39, 43	1001133137 32, 35	1702569.....23
0258842.....81	0902445 39, 43	1001133248 31, 35	1703072.....81
0270489.....27	0903671 45	1001133770 53	1703073.....81
0270490.....27	1001093646 23	1001133771 53	1703166.....31, 35
0270972.....28	1001096054 27, 31, 35	1001134102 53	1703681....23, 49, 51, 53, 81
0271828.....11	1001096586 23	1001139325 53	1703779.....81
0272127.....11	1001096587 23	1001141114 58	1703781.....81
0272159.....81	1001096767 28, 32, 36	1001141301 53	1703788.....81
0275697.....16	1001097212 28, 32, 36	1001141303 53	1704277.....41, 53
0275939.....16, 67	1001099638 49	1001141434 81	1705215.....81
0362735.....39, 43	1001099734 40, 61	1001141536 58	1705220.....81
0362736.....43	1001099754 40, 44	1001141754 51	1705633.....81
0440246.....39	1001100013 40, 44	1001144703 15, 23	1705634.....81
0440249.....39	1001100058 44, 61	1001144708 15	1705635.....81
0561149.....40, 44, 45	1001100544 67	1001144987 28, 32, 36	1705636.....11, 81
0561153.....41	1001100545 67	1001145887 28, 32, 36	2080040.....51, 53, 55
0561308.....44	1001103471 58	1001145893 28, 32, 36	2080043.....51, 53
0561336.....44	1001105113 15	1001145894 28, 32, 36	2220473.....67
0561341.....39, 43	1001109315 44	1001147215 15, 23	2220603.....67
0561408.....40, 44, 45	1001109405 43	1001147216 15	2400006.....23, 84
0561409.....41	1001110873 28, 32, 36	1001148902 88	2410024.....51
0630550.....15	1001111133 51	1001148903 88	2420172.....16
0641404.....16	1001111134 51	1001148904 88	2600225.....49
0641405.....55	1001111135 51	1001148905 88	2600294.....51, 53
0641406.....15, 40, 44	1001111558 39	1001148906 88	2820035.....55
0641407....28, 31, 35, 40, 44, 45	1001111560 39	1001156552 35	2860030.....15, 84
0641408.....40, 44, 49	1001111595 31, 35	1001167245 15	2880310.....39, 43
0641410....27, 31, 35, 55, 58	1001111597 55	1001175996 81	2902178.....40
0641414.....49, 58	1001111658 55	1001223055 81	2902179.....40
0641416.....51, 53	1001111659 55	1001228370 81	2915246.....67
0641418.....35	1001111660 55	1001233717 88	2940074.....49, 86
0641508.....39	1001111732 31	1001235146 39, 43	3020039.....40, 44
0641609.....11	1001111733 15, 23	1060380 49	3020041.....44
0641610.....11	1001111734 15	1060564 28	3252347.....32, 36
0641612.....27, 31, 35	1001111735 24	1060565 28	3252760.....28, 32, 36
0641622.....51, 53	1001111739 55	1060663 35, 36	3252761.....28, 32, 36
0641812.....39	1001111744 32	1060683 39, 43	3271805.....41
0641872.....40, 44	1001111750 32, 35	1060687 27, 36	3300356.....49
0681410.....40, 43	1001111751 55	1060694 27	3300430.....58
0681812.....41	1001111820 31, 35	1060922 27, 31	3310805.....58
0721004.....58	10011126224 67	1060924 28, 31	3311001....28, 31, 32, 36
0721006....15, 28, 32, 36, 49	1001125396 51	1060926 35	3311005.....15, 49, 58
0741006.....39, 43	1001125397 51	1260343 44	3311401.....39, 43
0741606.....43	1001125398 51	1260349 45	3311405....15, 27, 31, 35, 45, 49, 55, 58
0751003.....55	1001126088 11	1260355 44	3311505.....49
0791608.....15	1001126224 16	1260356 39, 40, 44	3311601.....39, 43
0791609.....16	1001128982 11	1260357 44, 45	3311605....11, 27, 31, 35, 51, 53
0801321.....11, 39	1001128986 35	1260361 40, 41	3311608.....11, 16
0801328.....11, 39	1001128987 81	1271392 39, 43	3311801.....39, 43
0801409.....11, 43	1001128989 58	1271419 43	3340845.....55
0860520.....49, 51, 53	1001128990 58	1271421 39, 43	3340858.....39, 43
0860943.....23	1001128991 45	1271446 43	3420355.....44
0860945.....27, 31	1001129306 32, 35	1271446 43	3422338....40, 41, 44, 45
0860946.....28	1001129307 32, 35, 86	1271515 39	3422346.....41, 44, 45
0861207.....27	1001130094 81	1271519 39	3422355.....41
0861305.....15	1001130481 58, 86	1320041 27, 31	3422657.....49
0861476.....15, 23	1001130482 58, 86	1320149 27, 31, 35	3422717.....39, 43
	1001131273 81	1580035 88	
	1001132308 58	1670603 27, 31	
	1001132309 58	1671255 40	
	1001132753 58	1684088 40, 63	
	1001132793 53	1700584 81	

PART NUMBER INDEX

3422720	44	4060700	28, 32	4460968.....	58	70000646.....	21
3422750	39, 43	4060803	49	4530010.....	23	70000647.....	21
3422752	39, 43	4060960	39, 43	4530013.....	23	70000648.....	21
3422757	39, 43	4060961	39, 43	4530023.....	23	70000649.....	21
3450202	44	4060987	44	4567489.....	43	70000650.....	21
3450304	41, 44, 45	4061024	16	4567491.....	40	70000651.....	19, 21
3450355	45	4070860	39, 43	4567492.....	44	70001020.....	19
3460311	55	4070861	39, 43	4567749.....	44	70001021.....	19
3510904	49	4070862	40, 43	4567750.....	40, 44	70001025.....	19, 84
3510905	49	4070970	40	4567751.....	40, 44	70001027.....	19
3520028	23, 51, 53	4070971	40	4568473.....	11	70001042.....	19
3520034	23, 27, 31	4070988	40, 43	4569478.....	67	70001044.....	19
3520072	49, 51, 53	4070989	40, 43	4569479.....	67	70001045.....	19
3539814	41	4070990	40, 43	4711400.....	16, 27, 31, 35,	70002092.....	61
3570893	40	4071095	51, 53	40, 44, 45, 49, 58		70002093.....	61
3570923	27, 31, 35	4160124	40, 43	4711500.....	40, 44, 45	70002094.....	61
3571101	41, 44, 45	4160130	27, 31, 35	4711600.....	11, 27, 31, 35,	70002095.....	61
3571103	41, 45	4160165	49	49, 51, 53		70002096.....	61
3572847	40	4220309	51, 53	4711800.....	40	70002215.....	19
3580231	27	4240033	32, 35, 45, 58	4740007.....	40, 44	70002429.....	61
3580269	39, 43	4300111	41, 45	4740414.....	40, 44	70003612.....	19
3580286	39, 43	4300129	44	4750800.....	40, 44, 58	70003613.....	19
3580293	39, 43	4341431	15	4751000.....	15, 27, 31, 35,	70005373.....	23
3580344	27, 31, 35	4341432	15	45, 49, 58		7002821.....	88
3600453	15, 19, 21	4360070	23, 84	4751400.....	15	7002823.....	88
3600467	15, 19, 21	4360161	23, 84	4751500.....	27, 31, 35, 41	7002826.....	88
3641663	49	4360376	23	4751800.....	41	7004275.....	88
3740049	23, 55, 84, 86	4360384	31, 35, 86	4761000.....	27, 28, 31, 32,	7004276.....	88
3740093	23, 84	4360467	15, 84	36, 40, 44		7012998.....	61, 63
3740094	23, 84	4360515	45	4761400.....	40, 44	7016654.....	88
3740105	23, 86	4360573	55	4761500.....	40	7020078	15, 27, 31, 35,
3740154	15	4360579	58, 86	4845345.....	41	84	
3760348	40, 44	4460023	27, 28, 31, 32,	4845813.....	49	7020088	27, 31, 35, 84
3760383	40, 43	36		4845821.....	49	7020089	27, 31, 35, 84
3820024	45, 49	4460035	55	4845914.....	11	7020091.....	27
3820032	27, 31, 35, 51,	4460044	23	4845929.....	55	7020093.....	15, 27, 32, 35
53, 55		4460071	31	4846381.....	40	7020094.....	15
3820034	39, 43	4460115	36	4846481.....	40	7020096.....	15
3900032	49	4460190	28	4846589.....	11	7020097.....	15
3900163	40	4460267	31, 32, 35, 45,	4892600.....	40, 44	7020183.....	31, 35
3900187	39, 43	55, 58		4922420.....	27	7023391.....	61, 63
3900191	27, 31	4460268	23, 31, 35, 55	4922546.....	23	7023392.....	61, 63
3900192	39, 43	4460315	36	4922645.....	24	7023393.....	63
3900200	27	4460320	55, 58	4922652.....	27, 31	7023394.....	63
3900205	28, 31, 32, 36,	4460326	32, 35	4922653.....	28, 31	7023395.....	61, 63
39, 43, 45		4460346	28, 32, 36	4922657.....	36	7023396.....	61, 63
3900258	49	4460424	23, 31, 35, 45	4922935.....	16	7023397.....	63
3900373	27, 31, 35	4460445	31, 35	4923131.....	23	7023398.....	63
3910804	15	4460467	88	4923150.....	23	7023399.....	61, 63
3910808	23	4460471	55	4923151.....	23	7023993.....	61, 63, 84
3911024	16	4460510	88	4933305.....	23	7026160.....	21
3930820	58	4460549	24, 28, 32, 36	70000641.....	19, 21	7026165.....	19, 21, 84
3931420	21	4460565	23	70000642.....	19, 21	7026330.....	19
3931428	58	4460566	15, 27, 31, 35	70000643.....	19, 21, 84	7026335.....	19, 21
3990010	27, 84	4460633	23	70000644.....	21	7027299.....	15, 27, 31, 35
4060092	28	4460662	58	70000645.....	21	8896941.....	88



3121155



An Oshkosh Corporation Company

Corporate Office
JLG Industries, Inc.
1 JLG Drive
McConnellsburg, PA 17233-9533 USA
☎ (717) 485-5161 (Corporate)
☎ (877) 554-5438 (Customer Support)
☎ (717) 485-6417

Visit our website for JLG Worldwide Locations.
www.jlg.com