

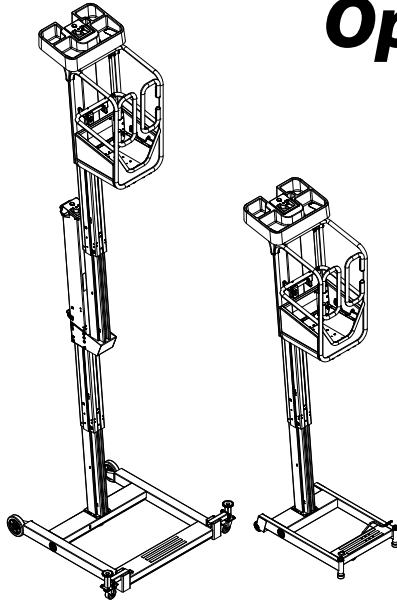

Operation, Safety, Service and Maintenance Manual

Keep this manual with the machine at all times.



LiftPod Models
FT70
FT140

ANSI / CSA

3121296
June 24, 2020 - Rev D



WARNING

Operating, servicing and maintaining this vehicle or equipment can expose you to chemicals including engine exhaust, carbon monoxide, phthalates, and lead, which are known to the State of California to cause cancer and birth defects or other reproductive harm. To minimize exposure, avoid breathing exhaust, do not idle the engine except as necessary, service your vehicle or equipment in a well-ventilated area and wear gloves or wash your hands frequently when servicing. For more information go to www.P65Warnings.ca.gov.

FOREWORD

This manual is a very important tool! Keep it with the machine at all times.

The purpose of this manual is to provide owners, users, operators, lessors, and lessees with the precautions and operating procedures essential for the safe and proper machine operation for its intended purpose.

Due to continuous product improvements, JLG Industries, Inc. (JLG) reserves the right to make specification changes without prior notification. Contact JLG for updated information.

Refer to www.JLG.com for Warranty, Production Registration, and other machine-related documentation.

SAFETY ALERT SYMBOLS AND SAFETY SIGNAL WORDS



This is the Safety Alert Symbol. It is used to alert you to the potential personal injury hazards. Obey all safety messages that follow this symbol to avoid possible injury or death

⚠ DANGER

INDICATES AN IMMINENTLY HAZARDOUS SITUATION. IF NOT AVOIDED, WILL RESULT IN SERIOUS INJURY OR DEATH. THIS DECAL WILL HAVE A RED BACKGROUND.

⚠ WARNING

INDICATES A POTENTIALITY HAZARDOUS SITUATION. IF NOT AVOIDED, COULD RESULT IN SERIOUS INJURY OR DEATH. THIS DECAL WILL HAVE AN ORANGE BACKGROUND.

⚠ CAUTION

INDICATES A POTENTIALITY HAZARDOUS SITUATION. IF NOT AVOIDED, MAY RESULT IN MINOR OR MODERATE INJURY. IT MAY ALSO ALERT AGAINST UNSAFE PRACTICES. THIS DECAL WILL HAVE A YELLOW BACKGROUND.

NOTICE

INDICATES INFORMATION OR A COMPANY POLICY THAT RELATES DIRECTLY OR INDIRECTLY TO THE SAFETY OF PERSONNEL OR PROTECTION OF PROPERTY.

⚠ WARNING

THIS PRODUCT MUST COMPLY WITH ALL SAFETY RELATED BULLETINS. CONTACT JLG OR THE LOCAL AUTHORIZED JLG REPRESENTATIVE FOR INFORMATION REGARDING SAFETY RELATED BULLETINS WHICH MAY HAVE BEEN ISSUED FOR THIS PRODUCT.

NOTICE

JLG MUST BE NOTIFIED IMMEDIATELY IN ALL INSTANCES WHERE JLG PRODUCTS HAVE BEEN INVOLVED IN AN ACCIDENT INVOLVING BODILY INJURY OR DEATH OF PERSONNEL OR WHEN SUBSTANTIAL DAMAGE HAS OCCURRED TO PERSONAL PROPERTY OR THE JLG PRODUCT.

For:

- Accident reporting
- Product safety publications
- Current owner updates
- Questions regarding product safety
- Standards and regulations compliance information
- Questions regarding special product applications
- Questions regarding product modifications

Contact:

Product Safety and Reliability Department
JLG Industries, Inc.
13244 Fountainhead Plaza
Hagerstown, MD 21742
USA

In USA:
Toll Free: 877-JLG-SAFE (877-554-7233)

Outside USA:
Phone: 717-485-6591
E-mail: ProductSafety@JLG.com

or your local JLG office
(see addresses on manual's rear cover)

REVISION LOG

Original Issue	A - November 2, 2015
Revised	B - March 1, 2016
Revised	C - June 29, 2018 - Revised, Prop 65
Revised	D - June 26, 2020

SECTION - 1 - SAFETY PRECAUTIONS

- 1.1 GENERAL 1-1
- 1.2 PRE-OPERATION 1-2
 - Operator Training and Knowledge 1-2
 - Workplace Inspection 1-2
 - Machine Inspection 1-3
- 1.3 OPERATION 1-4
 - General 1-4
 - Trip and Fall Hazard 1-5
 - Electrocution Hazard 1-6
 - Tipping Hazards 1-7
 - Crushing and Collision Hazards 1-9
- 1.4 MOVING, LIFTING AND REPOSITIONING 1-10
 - General 1-10
 - Additional Safety Information 1-10
- 1.5 MAINTENANCE 1-10
 - Maintenance Hazards 1-10
 - Battery Hazards 1-11

SECTION - 2 - PREPARATION AND INSPECTION

- 2.1 PERSONNEL TRAINING 2-1
 - Operator Training 2-1
 - Training Supervision 2-1
 - Operator Responsibility 2-1
- 2.2 PREPARATION, INSPECTION, AND

- MAINTENANCE 2-2
 - Pre-Start Inspection 2-3
- 2.3 DAILY WALK-AROUND INSPECTION 2-3
 - Walk-Around Inspection Components 2-3
 - Tool Tray Pre-Start Inspection 2-7
- 2.4 FUNCTION CHECK 2-8
 - Function Check Items 2-8

SECTION - 3 - MACHINE OPERATION

- 3.1 GENERAL 3-1
- 3.2 MACHINE DESCRIPTION 3-1
 - Base Component Detailed Description 3-4
 - Platform Configuration 3-5
 - Mast Components 3-5
- 3.3 MACHINE ASSEMBLY 3-6
 - General 3-6
 - Assembly of the Machine 3-7
 - Power Pack Control Unit Installation (Optional for FT70) 3-12
 - Machine Disassembly 3-13
- 3.4 MACHINE OPERATION 3-14
 - Positioning and Leveling Machine 3-14
 - Entering/Exiting The Platform 3-15
 - Platform Operation Using Cordless Drill 3-16
 - Platform Operation Using The Power Pack Control Unit 3-18

TABLE OF CONTENTS

- Platform Operation Using Manual Descent Tool 3-18
- 3.5 TRANSPORT AND MANEUVERING (MOVING) ... 3-19
 - General 3-19
 - Fully Assembled Maneuvering 3-19
 - Disassembled Maneuvering 3-20
 - Parking and Storage 3-21
 - Vehicle Transport 3-21
- 3.6 POWER PACK (OPTIONAL FOR FT70) 3-22
 - Emergency Stop/Shutdown Button 3-23
 - Mast Select Button 3-23
 - Function Enable Button 3-23
 - Platform UP/DOWN Buttons 3-23
 - Battery Status LED Indicator 3-23
 - Latch Release Handles (1 each side) 3-24
 - Control Unit/Drive Unit Driveshaft 3-24
 - Latch Locking Tabs 3-24
 - Lithium-Ion Battery 3-24
 - Connection Port for FT140 Drive Unit 3-24
 - Battery Operation 3-25
 - Removing Battery From Power Pack Control Unit 3-25
 - Battery Charge Status Lights 3-26

SECTION - 4 - EMERGENCY PROCEDURES

- 4.1 GENERAL INFORMATION 4-1

- Manual Descent Tool 4-1
- Platform - Manual Descent Tool Operation 4-2
- Ground - Manual Descent Tool Operation 4-3
- Platform Caught Overhead 4-4
- Operator Elevated In Platform - Platform Will Not Lower 4-4
- 4.2 INCIDENT NOTIFICATION 4-4

SECTION - 5 - GENERAL SPECIFICATIONS

- 5.1 INTRODUCTION 5-1
- 5.2 GENERAL SPECIFICATIONS 5-1
 - Platform Data 5-2
 - Optional Powerpack Electrical Specifications .. 5-2
 - Machine Component Weights 5-3
 - Serial Number Locations 5-4
- 5.3 DECAL REPLACEMENT 5-4
- 5.4 DECAL INSTALLATION 5-5

SECTION - 6 - SERVICE/MAINTENANCE And Replacement Parts

- 6.1 INTRODUCTION - MAINTENANCE SAFETY PRECAUTIONS 6-1
 - General 6-1
 - Maintenance Safety 6-2
- 6.2 MACHINE PREPARATION, INSPECTION AND MAINTENANCE 6-3

TABLE OF CONTENTS

General 6-3
Preparation, Inspection, and Maintenance 6-3
Pre-Start Inspection 6-3
Frequent and Pre-Delivery Inspection..... 6-3
Annual Machine Inspection..... 6-3
Preventive Maintenance..... 6-4

6.3 PREVENTIVE MAINTENANCE AND INSPECTION
SCHEDULE 6-4

6.4 SERVICING AND MAINTENANCE GUIDELINES 6-8
General 6-8
Safety and Workmanship..... 6-8
Cleanliness..... 6-8
Component Disassembly and Reassembly 6-8

6.5 FT70 AND FT140 MAST SERVICE PROCEDURE.... 6-9
Relieving Gas Strut Cylinder Pressure 6-11
Removing Mast Top Cap 6-13
Outer-Mast Section Gas Strut Removal..... 6-14
GearBox Removal 6-15
Mid-Mast Section Gas Strut Removal..... 6-16
Gearbox Housing Disassembly..... 6-16

6.6 MAST DRIVE SCREW LUBRICATION..... 6-18

6.7 REPLACEMENT PART/KITS OVERVIEW 6-20
BASE - FT140..... 6-20
BASE - FT70 6-20
MAST - FT70 and FT140..... 6-21
PLATFORM - FT70 and FT140 6-22

ACCESSORIES - FT70 and FT140 6-22

6.8 FT140 BASE FRAME COMPONENTS - SERVICE KIT - ..
LOCATIONS 6-24

6.9 FT70 BASE FRAME COMPONENTS - SERVICE KIT - ...
LOCATIONS 6-25

6.10 PLATFORM COMPONENT SERVICE KIT
LOCATIONS 6-26

6.11 ACCESSORY COMPONENTS - SERVICE KITS 6-27

SECTION - 7 - TROUBLESHOOTING

7.1 GENERAL..... 7-1
Troubleshooting Information 7-1

SECTION - 8 - INSPECTION AND REPAIR LOG

TABLE OF CONTENTS

LIST OF FIGURES

2-1.	Examples of cracks.....	2-4
2-2.	Daily Walk-Around Inspection (Sheet 1 of 2)	2-4
2-3.	Daily Walk-Around Inspection (Sheet 2 of 2)	2-5
2-4.	Platform latch shown engaged.....	2-6
2-5.	Location of manual descent tools	2-6
2-6.	Tool Tray Installation.....	2-7
3-1.	Machine Main Components (FT70)	3-2
3-2.	Machine Main Components (FT140)	3-3
3-3.	Base Frame Component Description - FT70.....	3-4
3-4.	Base Frame Component Description - FT140.....	3-4
3-5.	Platform Component Description	3-5
3-6.	Mast Component Description	3-5
3-7.	Mast Mount (Stump) Installation	3-7
3-8.	Mast to Base Installation (FT70).....	3-8
3-9.	Mast to Base/Mount Installation (FT140).....	3-9
3-10.	Platform Latch Engaged	3-10
3-11.	Platform to Mast Installation	3-10
3-12.	Tool Tray Installation.....	3-11
3-13.	Powerpack Control Unit Installation (FT70)	3-12
3-14.	Powerpack Installation (FT140).....	3-13
3-15.	Bubble Level Indicator - Machine Level	3-14
3-16.	Base Leveling.....	3-15
3-17.	Typical Cordless Drill Controls.....	3-17
3-18.	Cordless Drill Operation	3-17
3-19.	FT70 - Lift the handle to extend the swivel castor.....	3-20
3-20.	Power Pack Controller Components - (FT70) (Option)	3-22
3-21.	Battery Removal - Powerpack Control Unit	3-25
3-22.	Charge status lights	3-26
4-1.	Platform - Manual Descent Tool Operation	4-2
4-2.	Ground - Manual Descent Tool Operation	4-3
5-1.	Base Decal Installation - FT70	5-9
5-2.	Base Decal Installation - FT140.....	5-10
5-3.	Mast Decal Installation - FT70.....	5-11
5-4.	Mast Decal Installation - FT140.....	5-12
5-5.	Platform Decal Installation.....	5-13
5-6.	Tool Tray - Decal Installation.....	5-14
5-7.	Power Pack Control Unit - Decal Installation.....	5-15
5-8.	Power Pack Drive Unit - Decal Installation	5-16
5-9.	Battery Pack Decal Installation	5-17
5-10.	Battery Charger Decal Installation.....	5-18
6-1.	FT70 and FT140 - Mast Component Overview ...	6-9
6-2.	FT70 and FT140 - Mast Slide-Pad Positioning ...	6-10
6-3.	Lubrication Access Covers.....	6-18
6-4.	Mast Lubrication Points	6-18
6-5.	Safety Nut Housing Grease Cavity.....	6-19
6-6.	FT140 - Base Frame Components -Service Kit - Locations	6-24
6-7.	FT70 - Base Components - Service Kit -	

Locations6-25
6-8. Platform Component - Service Kit - Locations ..6-26
6-9. Accessory Components - Service Kit - Overview 6-27

LIST OF TABLES

1-1 Minimum Approach Distances (M.A.D.)1-6
2-1 Inspection and Maintenance Table.....2-2
5-1 Machine Specifications5-1
5-2 Platform Data5-2
5-3. Optional Powerpack Electrical Specifications ...5-2
5-4. Machine Component Weights5-3
5-5 Decal Descriptions.5-5
6-1. Preventative Maintenance & Inspection
Schedule6-5
7-1. Troubleshooting.....7-2

TABLE OF CONTENTS

SECTION 1. SAFETY PRECAUTIONS

1.1 GENERAL

This section outlines the necessary precautions for proper and safe machine usage and maintenance. In order to promote proper machine usage, it is mandatory that a daily routine is established based on the content of this manual. A maintenance program, using the information provided in the Service and Maintenance section, must also be established by a qualified person and must be followed to ensure that the machine is safe to operate.

The owner/user/operator/lessor/lessee of the machine must not accept operating responsibility until this manual has been read, training is accomplished, and operation of the machine has been completed under the supervision of an experienced and qualified operator.

These sections contain the responsibilities of the owner, user, operator, lessor, and lessee concerning safety, training, inspection, maintenance, application, and operation. If there are any questions with regard to safety, training, inspection, maintenance, application, and operation, please contact JLG Industries, Inc. ("JLG").

WARNING

FAILURE TO COMPLY WITH THE SAFETY PRECAUTIONS LISTED IN THIS MANUAL COULD RESULT IN MACHINE DAMAGE, PROPERTY DAMAGE, PERSONAL INJURY OR DEATH.

1.2 PRE-OPERATION

Operator Training and Knowledge

- This manual must be read and understood in its entirety before operating the machine. For clarification, questions, or additional information regarding any portions of this manual, contact JLG Industries, Inc.

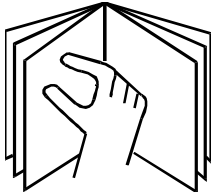

- An operator must not accept operating responsibilities until adequate training has been given by competent and authorized persons.
- Allow only those authorized and qualified personnel to operate the machine who have demonstrated that they understand the safe and proper operation and maintenance of the unit.
- Read, understand, and obey all DANGERS, WARNINGS, CAUTIONS, and operating instructions on the machine and in this manual.

- Ensure that the machine is to be used in a manner which is within the scope of its intended application as determined by JLG.
- All operating personnel must be familiar with the emergency controls and emergency operation of the machine as specified in this manual.
- Read, understand, and obey all applicable employer, local, and governmental regulations as they pertain to your utilization and application of the machine.

Workplace Inspection

- Precautions to avoid all hazards in the work area must be taken by the user before and during operation of the machine.
- Do not operate or raise the platform from a position on trucks, trailers, railway cars, floating vessels, scaffolds or other equipment unless the application is approved in writing by JLG.
- Before operation, check work area for overhead hazards such as electric lines, bridge cranes, and other potential overhead obstructions.
- Check floor surfaces for holes, bumps, drop-offs, obstructions, debris, concealed holes, and other potential hazards.

- Check the work area for hazardous locations. Do not operate the machine in hazardous environments unless approved for that purpose by JLG.
- Ensure that the ground conditions are adequate to support the maximum tire load indicated on the tire load decals located on the chassis adjacent to each wheel.
- This machine can be operated in nominal ambient temperatures of 0° F to 104° F (-20° C to 40° C). Consult JLG to optimize operation outside of this temperature range.
- Do not operate any machine on which the safety or instruction placards or decals are missing or illegible.
- Check the machine for modifications to original components. Ensure that any modifications have been approved by JLG.
- Avoid accumulation of debris on platform deck. Keep mud, oil, grease, and other slippery substances from footwear and platform deck.

Machine Inspection

- Do not operate this machine until the inspections and functional checks have been performed as specified in Section 2 of this manual.
- Do not operate this machine until it has been serviced and maintained according to the maintenance and inspection requirements as specified in the Service and Maintenance section of this manual.
- Ensure all safety devices are operating properly. Modification of these devices is a safety violation.

WARNING

MODIFICATION OR ALTERATION OF AN AERIAL WORK PLATFORM SHALL BE MADE ONLY WITH PRIOR WRITTEN PERMISSION FROM THE MANUFACTURER.

SECTION 1 - SAFETY PRECAUTIONS

1.3 OPERATION

General

- Machine operation requires your full attention. Bring the machine to a full stop before using any device, i.e. cell phones, two-way radios, etc. that will distract your attention from safely operating the machine.
 - Do not use the machine for any purpose other than positioning personnel, their tools, and equipment.
 - Before operation, the user must be familiar with the machine capabilities and operating characteristics of all functions.
 - Never operate a malfunctioning machine. If a malfunction occurs, shut down the machine. Remove the unit from service and notify the proper authorities.
 - Do not remove, modify, or disable any safety devices.
 - Never slam a control switch or lever through neutral to an opposite direction. Always return switch to neutral and stop before moving the switch to the next function. Operate controls with slow and even pressure.
 - Do not allow personnel to tamper with or operate the machine from the ground with personnel in the platform, except in an emergency.
- Do not carry materials directly on platform railing unless approved by JLG.
 - Always ensure that power tools are properly stowed and never left hanging by their cord from the platform work area.
 - Fully lower platform and shut off all power before leaving machine.
 - Remove all rings, watches, and jewelry when operating machine. Do not wear loose fitting clothing or long hair unrestrained which may become caught or entangled in equipment.
 - Persons under the influence of drugs or alcohol or who are subject to seizures, dizziness or loss of physical control must not operate this machine.

Trip and Fall Hazard

- Prior to operation, ensure all gates and rails are fastened and secured in their proper position.

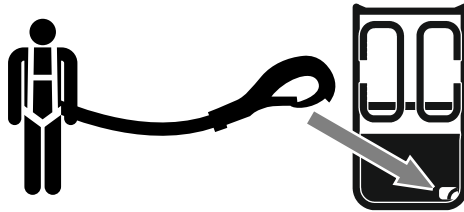

MAX = 36in. (91cm)

- JLG recommends that the operator utilizes a fall restraint system in the platform with a maximum 36 in. (91.4 cm) lanyard attached to an authorized lanyard anchorage point. For further information regarding fall protection requirements on JLG products, contact JLG.
- Identify the designated lanyard anchorage point at the platform and securely attach the lanyard. Attach only one (1) lanyard per lanyard anchorage point.
- Enter and exit only through gate area. Use extreme caution when entering or leaving platform. Ensure that the platform assembly is fully lowered. Face the machine when entering or leaving the platform. Always maintain “three point con-

tact” with the machine, using two hands and one foot or two feet and one hand at all times during entry and exit.

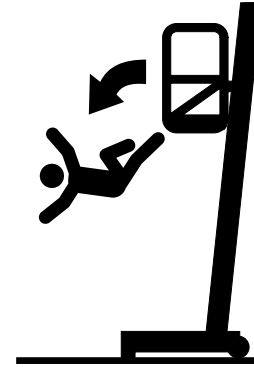

- Keep both feet firmly positioned on the platform floor at all times. Never position ladders, boxes, steps, planks, or similar items on unit to provide additional reach for any purpose.
- Never use the mas assembly to gain access to or leave the platform.
- Keep oil, mud, and slippery substances cleaned from footwear and the platform floor.

Electrocution Hazard

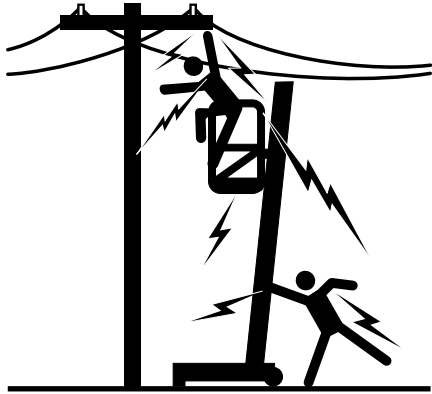

- This machine is not insulated and does not provide protection from contact or proximity to electrical current.
- Maintain distance from electrical lines, apparatus, or any energized (exposed or insulated) parts according to the Minimum Approach Distance (MAD) as shown in Table 1-1.
- Allow for machine movement and electrical line swaying.
- Maintain a clearance of at least 10 ft. (3m) between any part of the machine and its occupants, their tools, and their

equipment from any electrical line or apparatus carrying up to 50,000 volts. One foot additional clearance is required for every additional 30,000 volts or less.

Table 1-1. Minimum Approach Distances (M.A.D.)

VOLTAGE RANGE (Phase to Phase)	MINIMUM APPROACH DISTANCE in Feet (Meters)
0 to 50 KV	10 (3)
Over 50KV to 200KV	15 (5)
Over 200 KV to 350 KV	20 (6)
Over 350 KV to 500 KV	25 (8)
Over 500 KV to 750 KV	35 (11)
Over 750 KV to 1000KV	45 (14)

NOTE: *This requirement shall apply except where employer, local or governmental regulations are more stringent.*

- The minimum approach distance may be reduced if insulating barriers are installed to prevent contact, and the barriers are rated for the voltage of the line being guarded. These barriers shall not be part of (or attached to) the machine. The minimum approach distance shall be reduced to a distance within the designed working dimensions of the insulating barrier. This determination shall be made by a qualified person in accordance with the employer, local,

or governmental requirements for work practices near energized equipment.

⚠ DANGER

DO NOT MANEUVER MACHINE OR PERSONNEL INSIDE PROHIBITED ZONE (MAD). ASSUME ALL ELECTRICAL PARTS AND WIRING ARE ENERGIZED UNLESS KNOWN OTHERWISE.

Tipping Hazards

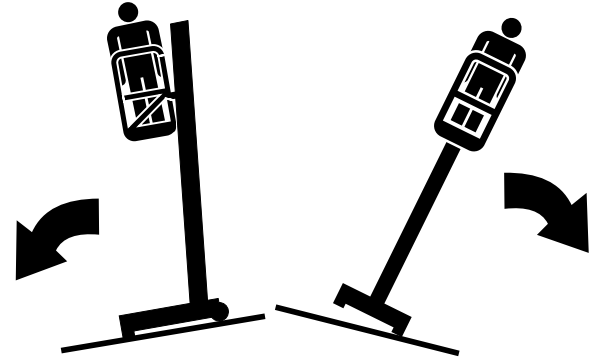

- Ensure that the ground conditions are adequate to support the maximum tire load indicated on the tire load decals located on the chassis adjacent to each wheel. Do not operate machine on unsupported surfaces.
- Do not elevate platform while on or near a sloping, uneven, or soft surface. Ensure machine is positioned on a firm, level and smooth surface before elevating platform.
- Before operating on floors, bridges, trucks, and other surfaces, check allowable capacity of the surfaces.

SECTION 1 - SAFETY PRECAUTIONS

- Never exceed the maximum work load as specified on the platform. Keep all loads within the confines of the platform, unless authorized by JLG.
- Keep the chassis of the machine a minimum of 2 ft. (0.6m) from holes, bumps, drop-offs, obstructions, debris, concealed holes, and other potential hazards at the ground level.
- Never operate machine in high wind, rain or snow.
- Do not perform work that will subject unit to a horizontal force or create a swaying motion of the platform.

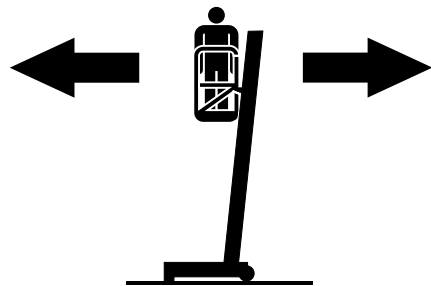

- Never attempt to use the machine as a crane. Do not tie-off machine to any adjacent structure. Never attach wire, cable, or any similar items to platform.
- Do not cover the platform sides or carry large surface-area items in the platform when operating outdoors. The addition of such items increases the exposed wind area of the machine.
- Do not increase the platform size with unauthorized deck extensions or attachments.
- If the mast assembly or platform is caught so that one or more wheels are off the ground, platform personnel must be removed before attempting to free the machine. Use cranes, forklift trucks, or other appropriate equipment to stabilize machine and remove personnel.

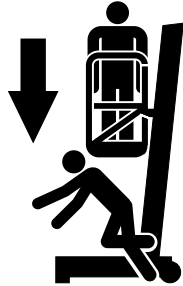
Crushing and Collision Hazards

- Approved head gear must be worn by all operating and ground personnel.
- Watch for obstructions around machine and overhead when driving. Check clearances above, on sides, and bottom of platform when lifting or lowering platform.
- During operation, keep all body parts inside platform railing.
- Keep non-operating personnel at least 6 ft. (1.8m) away from machine during all operations.
- When moving the machine, the operator must limit travel speed according to conditions of ground surface, conges-

tion, visibility, slope, location of personnel, and other factors.

- Exercise extreme caution at all times to prevent obstacles from striking or interfering with operating controls and persons in the platform.
- Ensure that operators of other overhead and floor level machines are aware of the aerial work platform's presence. Disconnect power to overhead cranes. Barricade floor area if necessary.
- Do not operate over ground personnel. Warn personnel not to work, stand, or walk under a raised platform. Position barricades on floor as necessary.

1.4 MOVING, LIFTING AND REPOSITIONING

General

- Never allow personnel in platform while moving, lifting or repositioning the machine.
- This machine shall not be towed by a vehicle.
- Do not move assembled unit on wheels over soft or uneven surfaces, or over obstructions, bumps, debris, etc.
- Disassemble unit to transport over uneven or sloped ground, or in a vehicle.
- Ensure platform is fully retracted and completely empty of tools prior to disassembly, lifting or hauling.
- Remove powerpack and tool tray (if fitted) from platform when transporting in a vehicle.
- Refer to the Machine Operation section of this manual for lifting information.

Additional Safety Information

- Do not use machine as ground for welding.
- Do not attempt to transport assembled machinery by forklift.

1.5 MAINTENANCE

This sub-section contains general safety precautions which must be observed during maintenance of this machine. Additional precautions to be observed during machine maintenance are inserted at the appropriate points in this manual and in the Service and Maintenance section of this manual. It is of utmost importance that maintenance personnel pay strict attention to these precautions to avoid possible injury to personnel or damage to the machine or property. A maintenance program must be established by a qualified person and must be followed to ensure that the machine is safe.

Maintenance Hazards

- Shut off power to all controls and ensure that all moving parts are secured from inadvertent motion prior to performing any adjustments or repairs.
- Never work under an elevated platform until it has been fully lowered to the full down position, if possible, or otherwise supported and restrained from movement with appropriate safety props, blocking, or overhead supports.
- Ensure replacement parts or components are identical or equivalent to original parts or components.
- Never attempt to move heavy parts without the aid of a mechanical device. Do not allow heavy objects to rest in an

unstable position. Ensure adequate support is provided when raising components of the machine.

- Use only approved non-flammable cleaning solvents.
- Do not replace items critical to stability, with items of different weight or specification. Do not modify unit in any way to affect stability.
- Reference the Service and Maintenance section of this manual for the weights of critical stability items.

⚠ WARNING

MODIFICATION OR ALTERATION OF AN AERIAL WORK PLATFORM SHALL BE MADE ONLY WITH PRIOR WRITTEN PERMISSION FROM THE MANUFACTURER.

Battery Hazards

- Do not allow smoking, open flame, or sparks near battery during charging or servicing.
- Do not contact tools or other metal objects across the battery terminals.
- Always wear hand, eye, and face protection when servicing batteries. Ensure that battery acid does not come in contact with skin or clothing.

⚠ CAUTION

BATTERY FLUID IS HIGHLY CORROSIVE. AVOID CONTACT WITH SKIN AND CLOTHING AT ALL TIMES. IMMEDIATELY RINSE ANY CONTACTED AREA WITH CLEAN WATER AND SEEK MEDICAL ATTENTION.

- Charge batteries only in a well ventilated area.

SECTION 1 - SAFETY PRECAUTIONS



NOTES:

SECTION 2. PREPARATION AND INSPECTION

2.1 PERSONNEL TRAINING

The aerial platform is a personnel handling device; so it is necessary that it be operated and maintained only by trained personnel.

The manual supplied with the machine is an important part of operator training.

Persons under the influence of drugs or alcohol or who are subject to seizures, dizziness or loss of physical control must not operate this machine.

Operator Training

Operator training must cover:

1. Use and limitations of the controls in the platform and emergency controls.
2. Decals, instructions, and warnings on the machine.
3. Rules of the employer and government regulations.
4. Correct assembly of the machine.
5. Use of approved fall protection device.
6. Enough knowledge of the mechanical operation of the machine to recognize a malfunction or potential malfunction.

7. The safest means to operate the machine where overhead obstructions, other moving equipment, and obstacles, depressions, holes, drop-offs are present.
8. Means to avoid the hazards of unprotected electrical conductors.
9. Specific job requirements or machine application.

Training Supervision

Training must be done under the supervision of a qualified person in an open area free of obstructions until the trainee has developed the ability to safely control and operate the machine.

Operator Responsibility

The operator must be instructed that he/she has the responsibility and authority to shut down the machine in case of a malfunction or other unsafe condition of either the machine or the job site.

SECTION 2 - PREPARATION AND INSPECTION

2.2 PREPARATION, INSPECTION, AND MAINTENANCE

The following table covers the periodic machine inspections and maintenance recommended by JLG. Consult local regulations for further requirements for aerial work platforms.

The frequency of inspections and maintenance must be increased as necessary when the machine is used in a harsh or hostile environment, if the machine is used with increased frequency, or if the machine is used in a severe manner.

Table 2-1. Inspection and Maintenance Table

TYPE	FREQUENCY	PRIMARY RESPONSIBILITY	SERVICE QUALIFICATION	REFERENCE
Pre-Start Inspection	Before starting each day or at each workshift change	Operator	User or Operator	Operation, Safety, Service & Maintenance Manual
Frequent Inspection	In service for 3 months; out of service for a period of more than 3 months; or purchased used.	Owner, Dealer or User	Qualified Mechanic (*)	Operation, Safety, Service & Maintenance Manual and applicable JLG LiftPod inspection form
Annual Machine Inspection	Every 12 months	Owner, Dealer or User	Qualified Mechanic (*)	Operation, Safety, Service & Maintenance Manual and applicable JLG LiftPod inspection form
NOTE: Use this manual to perform inspections.				
NOTE: (*) A person who has acquired by training, qualifications, experience or a combination of these, the knowledge and skill enabling the person to inspect and repair the machine to the level required by the complexity of the task.				

Pre-Start Inspection

The Pre-Start Inspection should include each of the following:

1. **Cleanliness** – Check all surfaces for leakage, debris or foreign objects.
2. **Decals and Placards** – Check all for cleanliness and legibility. Make sure none of the decals and placards are missing. Make sure all illegible decals and placards are cleaned or replaced. (Reference Section 5.3, DECAL REPLACEMENT and Section 5.4, DECAL INSTALLATION).
3. **Operation, Safety Service & Maintenance Manual** – Make sure a copy of the Operation, Safety, Service & Maintenance Manual, AEM Safety Manual, and ANSI Manual of Responsibilities is enclosed in the weather resistant storage container.
4. **Assembly** – The machine must be fully assembled in accordance with Section 3.3.
5. **Walk-Around Inspection** – Refer to Section 2.3.
6. **Powerpack** – Charge as required (Section 3.6).
7. **Function Check** – Once the Walk-Around Inspection is complete, perform a function check of all systems in an area free of overhead and ground level obstructions. Refer to Section 2.4 for more specific instructions.

2.3 DAILY WALK-AROUND INSPECTION

Begin the Walk-Around Inspection at item one (1) as noted on the diagrams Figure 2-2. and Figure 2-3. Continue around machine checking each item in sequence for the conditions listed in the following check list.

WARNING

TO AVOID POSSIBLE INJURY, BE SURE DIRECTION SELECTOR IS IN THE “OFF” POSITION DURING WALK-AROUND INSPECTION. DO NOT OPERATE MACHINE UNTIL ALL MALFUNCTIONS HAVE BEEN CORRECTED.

NOTE: *Do not overlook visual inspection of the base frame underside. Check this area for objects, debris, corrosion and cracks.*

Walk-Around Inspection Components

INSPECTION NOTE: *On all components, make sure there are no loose or missing parts, everything is securely fastened, no visible damage, or excessive wear exists in addition to any other criteria mentioned.*

1. **Rear Wheels** - Check for any debris stuck to or around wheels. Make sure axle bolts are fastened.
2. **Base Frame** - Check for cracks or corrosion, especially around the mast-stump base (see Figure 2-1.). Check

SECTION 2 - PREPARATION AND INSPECTION

level indicator is clean, secure and responds to movement.

- 3. Base - Platform Emergency Lowering Tool** - Check that the platform emergency lowering tool is in place on the base frame and in good working order.
- 4. Mast Assembly(s) - (Check both mast assemblies on the FT140 model)** No cracks or corrosion, especially around base of mast; no excess wear, kinks, nicks or damage; slide pad running surfaces smooth and unobstructed; free of dirt or debris.

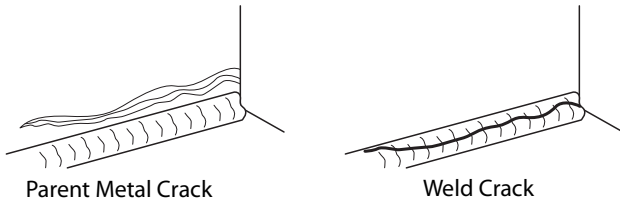

Figure 2-1. Examples of cracks

- 5. Platform Latch Assembly** - With platform not mounted to mast, inspect the mast pin mounts and their connections for any signs of damage. If no damage is present to the mounts, with platform mounted to mast, check that latch assembly is engaged with

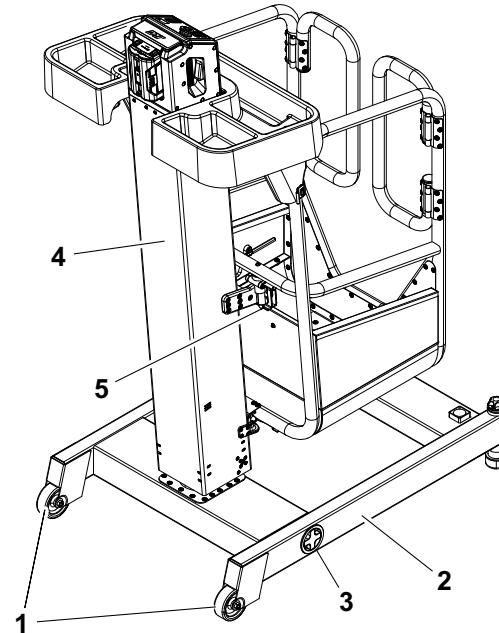

Figure 2-2. Daily Walk-Around Inspection
(Sheet 1 of 2)

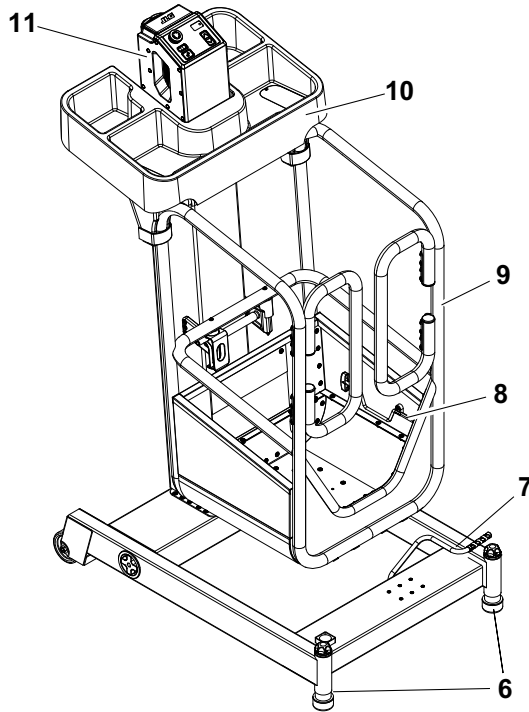

Figure 2-3. Daily Walk-Around Inspection
(Sheet 2 of 2)

bottom of mast pin mount when released, see Figure 2-4.

- 6. Adjustable Leveling Feet/Locking Castor Wheel** - Check for any debris stuck to or around mechanism. Check for damage. **FT70**-Non-skid pads (on bottom of foot) must be in good working order. **FT140** - Castor wheel swivels freely and wheel brake working properly.
- 7. Swivel Castor Mechanism (FT70)** - Engage handle is not bent or broken. Check for any debris stuck to or around mechanism. Castor wheel swivels freely.
- 8. Manual Descent Crank** - Ensure it is present and securely attached in platform (See Figure 2-5.).
- 9. Platform Assembly and Gate** - Check mounting pins are not loose; platform railing is undamaged; self-closing entry gates are in proper working order; no cracks or corrosion visible.
- 10. Tool Tray** - See "Tool Tray Pre-Start Inspection" on page 2-7.
- 11. Powerpack - Control and Drive Unit (FT70 - Control Unit optional)** - Ensure it is properly mounted and latched onto mast cap. Button, triggers and switches not obscured or damaged; decals secure and legible; emergency stop switch reset for operation; control markings legible. Battery is installed and secure.

SECTION 2 - PREPARATION AND INSPECTION

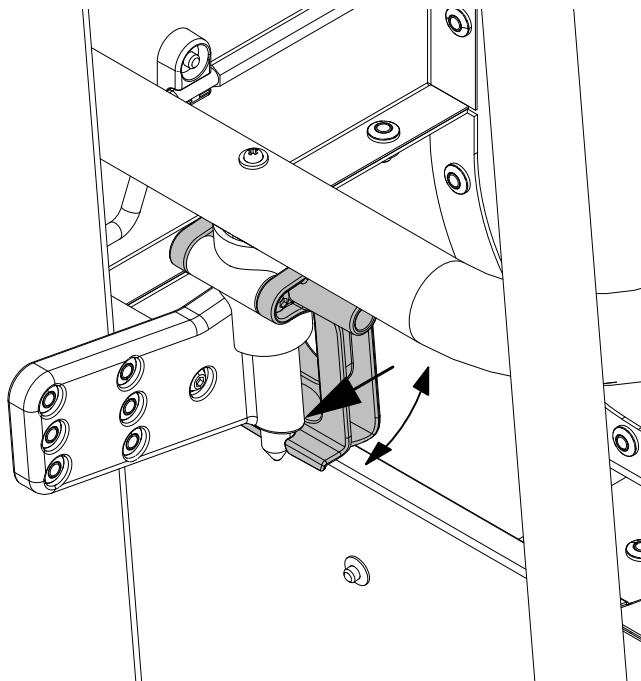

Figure 2-4. Platform latch shown engaged

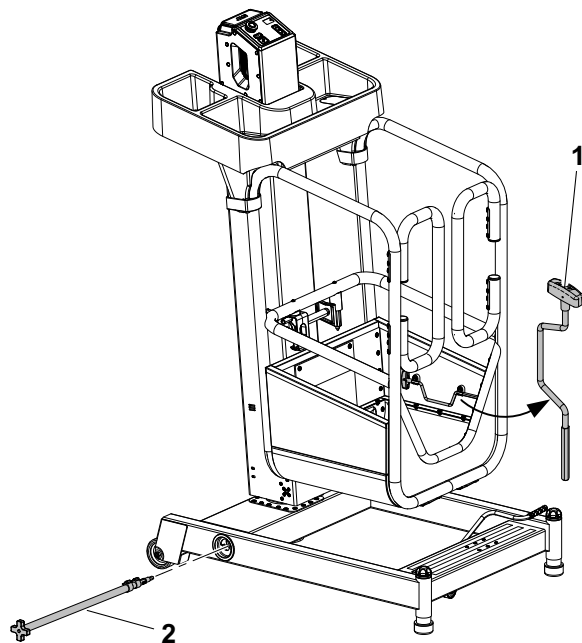

Figure 2-5. Location of manual descent tools

1. Platform - Manual Descent Tool
2. Ground - Manual Descent Tool

Tool Tray Pre-Start Inspection

Prior to use of the tool tray, check the following:

- Tool tray is seated securely on the platform top and side rails and resting on the mast top carry handle.
- No cracks or bends in tray.
- Both of the straps are securely attached to the platform side rails (See Figure 2-6.).
- Decals are in place and legible.

Maximum Load: The maximum permissible load on the tool tray is 33 lb. (15kg) evenly distributed.

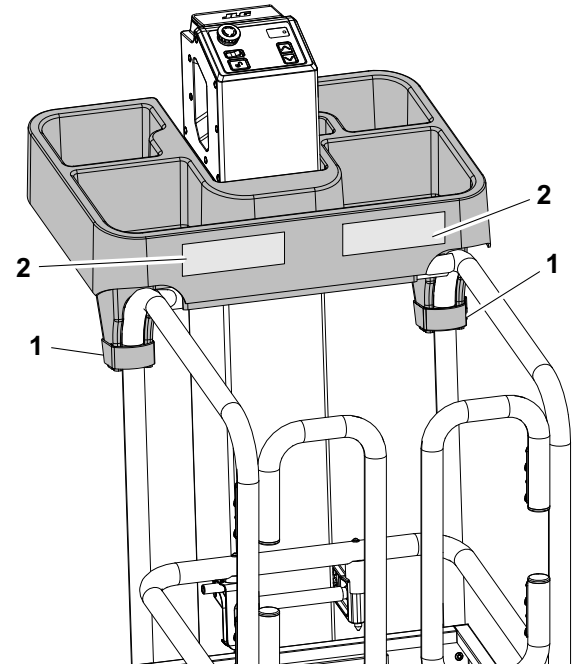

1. Tray Attach Straps 2. Decals

Figure 2-6. Tool Tray Installation

SECTION 2 - PREPARATION AND INSPECTION

2.4 FUNCTION CHECK

Once the Walk-Around inspection is complete, perform a function check of all systems in an area free of overhead and ground level obstructions.

WARNING

IF THE MACHINE DOES NOT OPERATE PROPERLY, TURN OFF THE MACHINE IMMEDIATELY! REPORT THE PROBLEM TO THE PROPER MAINTENANCE PERSONNEL OR CALL JLG CUSTOMER SERVICE DEPARTMENT. DO NOT OPERATE THE MACHINE UNTIL IT IS DEEMED SAFE FOR OPERATION.

Function Check Items

1. Assemble and set-up machine for operation according to Section 3.3, MACHINE ASSEMBLY.
2. **Base** -
FT70 - Step on base to ensure the swivel castor mechanism fully retracts and base sits on leveling feet.
FT140 - Both front castor wheel brakes, when engaged, stop machine from rolling.
3. **Adjustable Leveling Feet or Castors** - Check both move freely up and down for machine leveling;
4. **Platform Gates** - Check that both close properly after entering platform.

5. **Cordless Drill Operation (if equipped)** - Check that the drill power button when released stops all mast movement and drill battery is fully charged.
6. **Mast Drive Enable** - When using cordless drill with the hex drive bit, check that the drive gear must be pushed down to engage the mast drive gears and will disengage when released.
7. **Powerpack Control Unit - (if equipped) - Emergency Stop Button** - ensure all machine functions are disabled when the emergency stop button is activated (pressed in) - then **RESET** the emergency stop button by twisting it in the direction indicated by the arrows.
Enable Button - check that enable button must be pressed before platform up and down functions operate.

WARNING

TO AVOID COLLISION AND INJURY IF PLATFORM DOES NOT STOP WHEN A CONTROL IS RELEASED, USE THE EMERGENCY STOP BUTTON TO STOP PLATFORM MOVEMENT.

8. **Mast Operation** - Enter the platform and operate mast up and down 2 or 3 feet using the cordless drill or powerpack, check for smooth operation.

SECTION 3. MACHINE OPERATION

3.1 GENERAL

NOTICE

THE MANUFACTURER HAS NO DIRECT CONTROL OVER MACHINE APPLICATION AND OPERATION. THE USER AND OPERATOR ARE RESPONSIBLE FOR CONFORMING WITH GOOD SAFETY PRACTICES.

This section provides the necessary information needed to understand control function and operation.

3.2 MACHINE DESCRIPTION

The JLG LiftPod is a portable aerial work platform. The complete machine can be assembled and disassembled and moved around from work place to work place. The work platform is mounted to a mast, which is mounted to the base frame. The personnel lift's intended purpose is to provide personnel access to areas above level ground. The platform must **ONLY** be elevated on a **FIRM, LEVEL, and UNIFORM SURFACE**.

When power is applied to the drive shaft port at the top of the mast, the mast extends and lifts the platform vertically. During normal operation, the mast can be extended and retracted using one of two methods, using a rechargeable heavy duty battery operated cordless drill, or the optional rechargeable power pack unit. In case of complete loss of power when the

platform is elevated, a manual descent hand crank is included and mounted in the platform. Also, a telescoping manual descent tool is installed in the base frame and can retract the mast and lower the platform from the ground.

The FT70 machine base frame has a self retracting swivel castor wheel mounted under the front of the base for quick repositioning of the machine when the platform is not loaded. When loaded, it retracts out of ground contact and the load transfers to the base adjustable leveling feet.

The FT140 machine base have two castor wheels equipped with brakes mounted to each front corner of the machine, this allows for quick repositioning of the machine when the platform is not loaded and the castor brakes are released.

SECTION 3 - MACHINE OPERATION

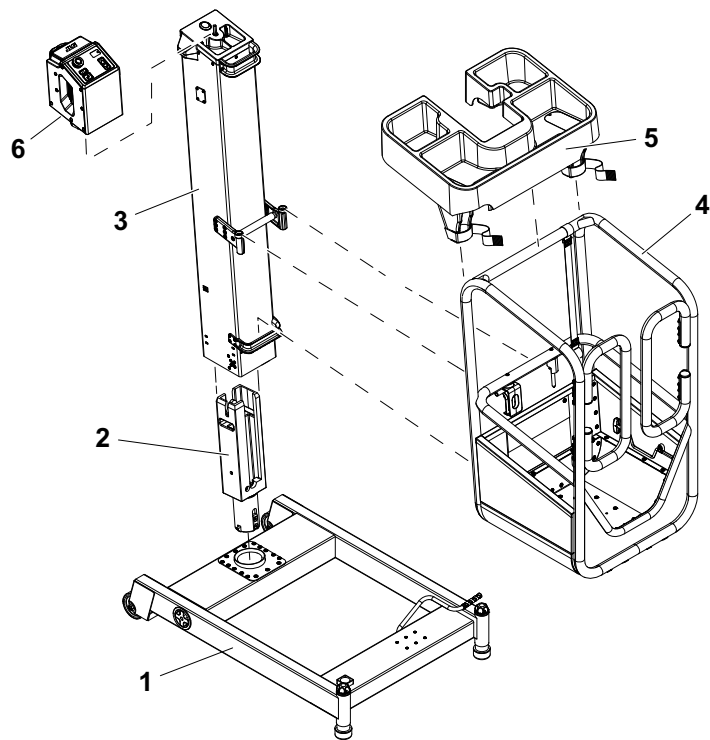

1. FT70 Base Frame
2. FT70 Mast Mount (stump)
3. FT70 Mast Assembly
4. Platform
5. Tool Tray
6. Power Pack (Optional for FT70)

NOTE: The component list above also represents the order of assembly for components 1 thru 6.

Figure 3-1. Machine Main Components (FT70)

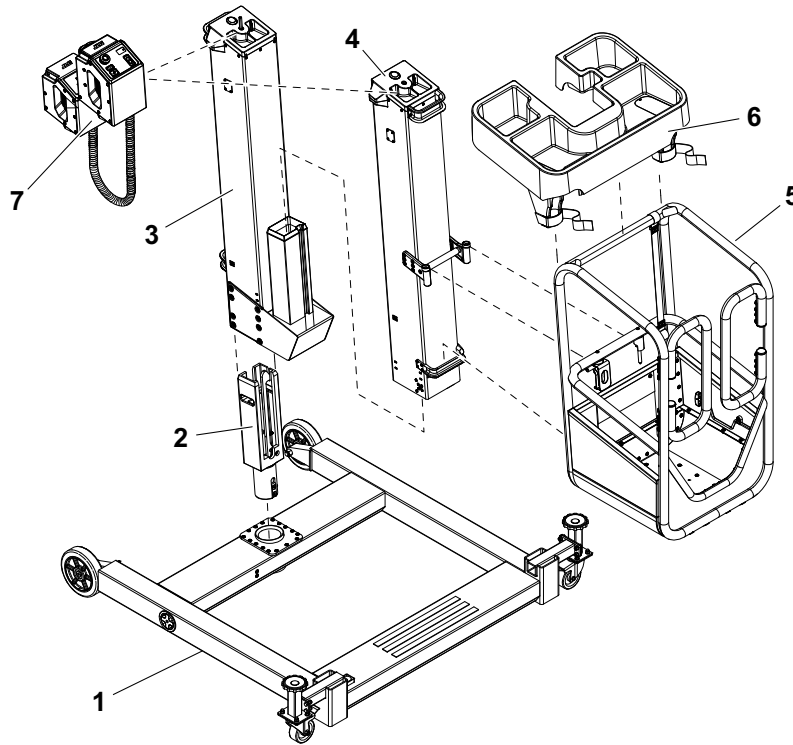

1. FT140 Base Frame
2. FT140 Mast Mount (stump)
3. FT140 Mast Assembly
4. FT70 Mast Assembly
5. Platform
6. Tool Tray
7. Power Pack (Control Unit/Drive Unit/Connect Cable - Standard on FT140)

NOTE: *The component list above also represents the order of assembly for components 1 thru 7.*

Figure 3-2. Machine Main Components (FT140)

Base Component Detailed Description

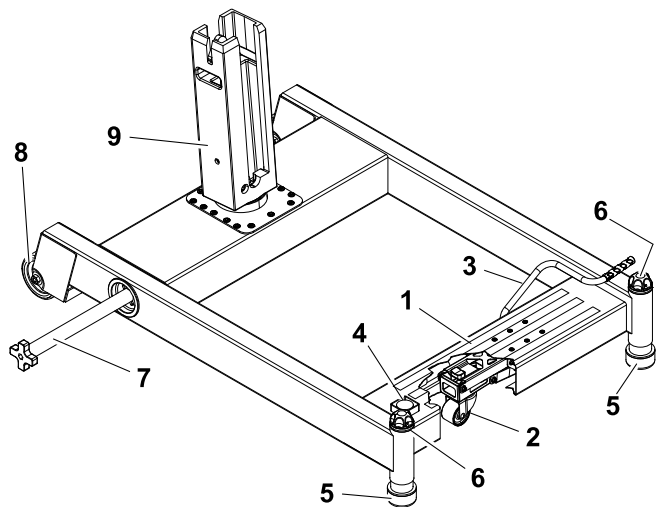

Figure 3-3. Base Frame Component Description - FT70

- | | |
|----------------------------------|----------------------------------|
| 1. Step Plate | 6. Base Leveling Adjustment Knob |
| 2. Self Retracting Swivel Castor | 7. Platform Manual Descent Tool |
| 3. Castor Deployment Lever | 8. Rear Fixed Base Wheels |
| 4. Bubble Level Indicator | 9. Mast Mount (stump) |
| 5. Adjustable Leveling Feet | |

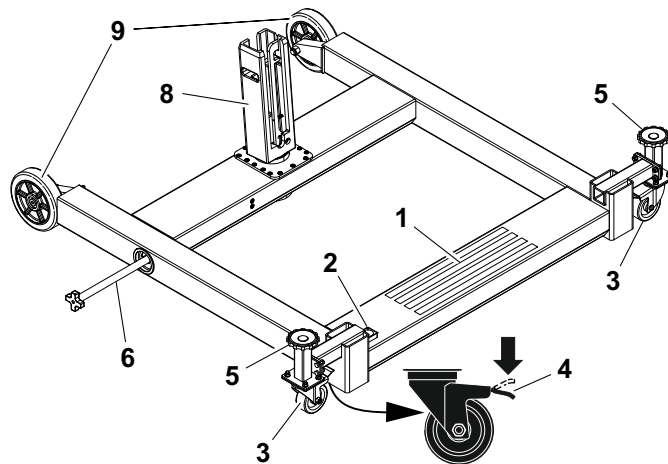

Figure 3-4. Base Frame Component Description - FT140

- | | |
|----------------------------------|---------------------------------|
| 1. Step Plate | 6. Platform Manual Descent Tool |
| 2. Bubble Level Indicator | 7. Rear Fixed Base Wheels |
| 3. Swivel Castor Wheels | 8. Mast Mount (stump) |
| 4. Castor Wheel Brake Lever | |
| 5. Base Leveling Adjustment Knob | |

Platform Configuration

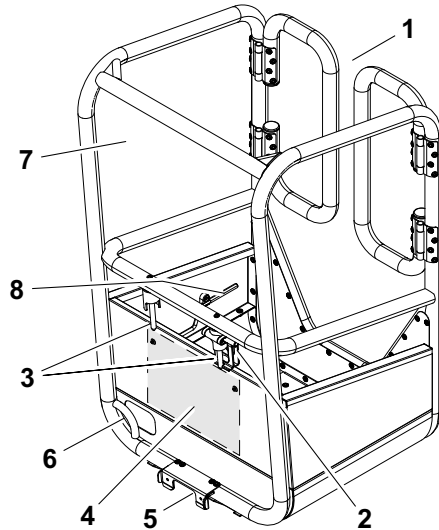

Figure 3-5. Platform Component Description

- | | |
|---|-----------------------------------|
| 1. Platform Swing Gates | 5. Lower Platform Mount |
| 2. Platform To Mast Latch | 6. Lanyard Attach Point |
| 3. Platform Mounting Pins | 7. Cordless Drill - Lanyard Strap |
| 4. Manual Storage Pouch - (located inside platform) | 8. Platform Manual Descent Tool |

Mast Components

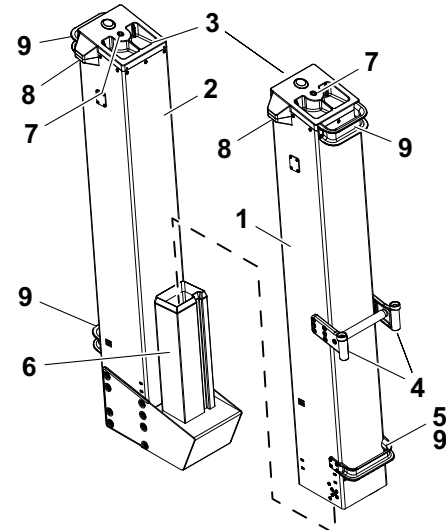

Figure 3-6. Mast Component Description

- | | |
|-----------------------------------|------------------------------|
| 1. FT70 Mast Assy. | 6. FT70 Mast Mount |
| 2. FT140 Mast Assy. (plus item 1) | 7. Mast Drive Shaft Port |
| 3. Mast Cap | 8. Manual Descent Drive Port |
| 4. Platform Pin Mounts | 9. Portable Carry Handle |
| 5. Platform Lower Mount | |

3.3 MACHINE ASSEMBLY

General

NOTICE

THE MANUFACTURER HAS NO DIRECT CONTROL OVER MACHINE APPLICATION AND OPERATION, THE USER AND OPERATOR ARE RESPONSIBLE FOR CONFORMING WITH GOOD SAFETY PRACTICES.

This section provides the necessary information needed to understand how to properly operate the machine.

- Do not attempt to elevate with no load in the platform.
- The platform has a total capacity of **330 lb. (150kg)**.
- The machine is not intended for use by children.
- Children must be supervised to ensure they do not use or play with the machine.
- Only **one** person is allowed to be lifted by the platform.



⚠ WARNING

DO NOT RAISE PLATFORM EXCEPT ON A SMOOTH, FIRM AND LEVEL SURFACE FREE OF OBSTRUCTIONS AND HOLES.

TO AVOID SERIOUS INJURY, DO NOT OPERATE MACHINE IF ANY (POWER-PACK) CONTROL LEVERS OR TOGGLE SWITCHES CONTROLLING PLATFORM MOVEMENT DO NOT RETURN TO THE OFF OR NEUTRAL POSITION WHEN RELEASED.

IF THE PLATFORM DOES NOT STOP WHEN A CONTROL SWITCH OR LEVER IS RELEASED, USE THE EMERGENCY STOP SWITCH TO STOP THE MACHINE.

Assembly of the Machine

⚠ WARNING

DO NOT ATTEMPT TO ASSEMBLE OR USE A MAST ON A BASE FOR WHICH IT IS NOT INTENDED. THE MAST MOUNT (STUMP) IS NOT INTERCHANGEABLE BETWEEN THE FT70 AND FT140. ALWAYS CHECK THE MAST IS FULLY INSERTED ONTO THE MAST MOUNT PRIOR TO OPERATION.

1. Position the base frame under work area on a firm, level, uniform, supporting surface.
2. Once positioned;
FT70 - push down on the base frame's step plate until the front swivel castor retracts and the base sits on the adjustable feet at the front of the machine.
FT140 - Lock the brakes on the front swivel castor wheels.
3. If not already installed into base, grasp the mast mount (stump) using the handle slots on the side of the mount, align the key plate (4) on the mast mount (stump) with the key slot (5) in the base receptacle (1), slide the mount into the base frame receptacle until bottomed. The mount lever latch (3) must engage in the side slot at the bottom of the base receptacle (1).

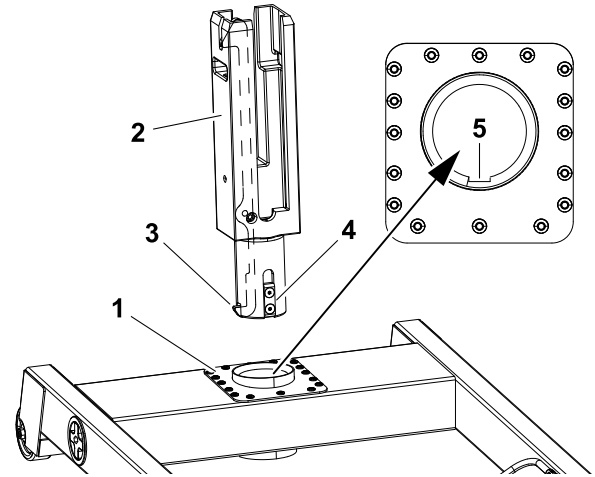

Figure 3-7. Mast Mount (Stump) Installation

- | | |
|--------------------------------------|------------------------|
| 1. Base Frame Receptacle | 4. Mount Key Plate |
| 2. Mast Mount (Stump) ⁽¹⁾ | 5. Receptacle Key Slot |
| 3. Mount Lever Latch ⁽²⁾ | |

NOTE: (1) FT70/FT140 - Lubricate the mating surfaces of the mast mount(s) once a month, see Table 6-1., Preventative Maintenance & Inspection Schedule.
 (2) FT70 shown, FT140 same except the mount lever latch is on the opposite side of mount shown above.

SECTION 3 - MACHINE OPERATION

4. **FT70** - (See Figure 3-8.) Next install the mast (1) over the mast mount (stump) (2).

FT140 - (See Figure 3-9.) Install the FT140 mast assembly (1) to the base FT140 mast mount (stump) (2). Then install the FT70 mast assembly (3) onto the FT70 mast mount (stump) (4) located on the FT140 mast assembly (1).

NOTICE

THE FT140 MAST SECTION IS HEAVIER THAN THE FT70 MAST, JLG RECOMMENDS THAT TWO PEOPLE LIFT THE FT140 MAST ONTO THE BASE MAST MOUNT (STUMP). THEN THE FT70 MAST ONTO THE FT140 MAST MOUNT.

- a. Set the mast upright on the floor next to the base.
- b. Ensure the mast mount (2) (stump) is already properly installed on the base.
- c. When lifting the mast assembly (1) use the lifting handles at top and bottom as much as possible. Keep your back straight and lift the mast assembly with your legs and walk carefully towards the base and slide the mast assembly (1) onto the mast mount (stump) (2) on the base frame. Make sure it is properly aligned and fully engaged. Never force it into position.

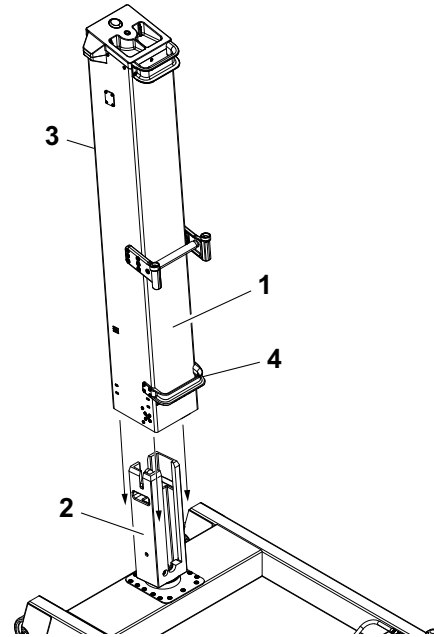

Figure 3-8. Mast to Base Installation (FT70)

- | | |
|-----------------------|--|
| 1. Mast Assembly | 3. Upper Lifting Area |
| 2. Mast Mount (Stump) | 4. Lower Platform Mount/Lifting Handle |

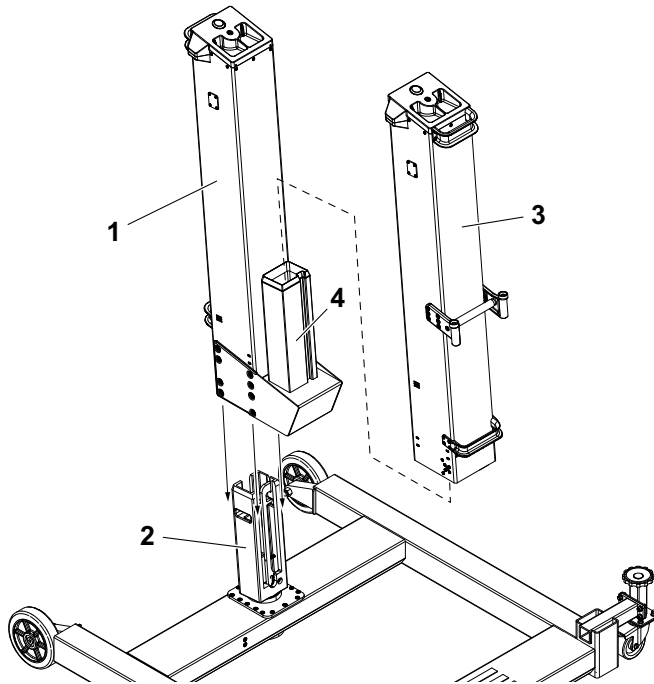

Figure 3-9. Mast to Base/Mount Installation (FT140)

- | | |
|----------------------------------|----------------------------|
| 1. FT140 Mast Assembly | 3. FT70 Mast Assembly |
| 2. FT140 Base Mast Mount (Stump) | 4. FT70 Mast Mount (Stump) |

5. Attach the platform to the mast (See Figure 3-10. and Figure 3-11.).
 - a. Lift up on the platform latch handle and hold open.
 - b. Lift the platform onto the mast, be certain the platform's mounting pins are aligned with the holes in the mast pin mounts, and the platform lower mount is properly engaged over the lower mount bracket, then slowly lower platform down to seat properly.
 - c. Release the platform latch handle until it is fully engaged under the pin mount.

CHECK: Try to lift the platform out, if it does not release, then the platform has engaged properly. (See Figure 3-10.)

NOTE: When reversing the procedure to disassemble the machine, lift up on the platform latch handle to release it and lift the platform from the mast.

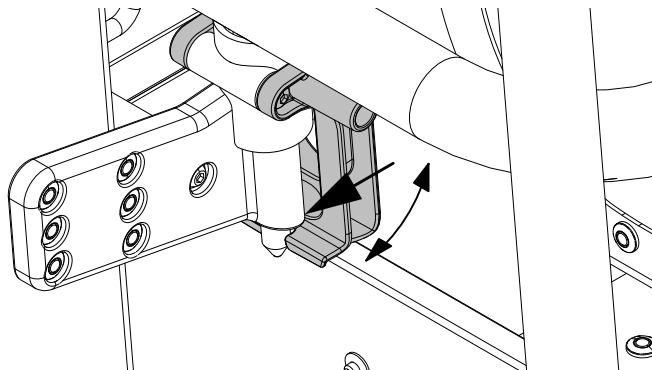

Figure 3-10. Platform Latch Engaged

Platform Latch Handle Engaged Under Mast/Platform Pin Mount.

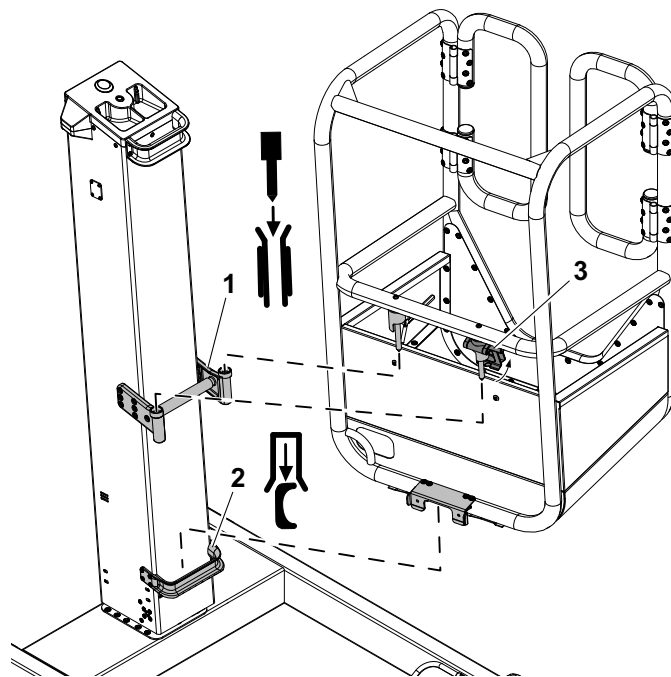

Figure 3-11. Platform to Mast Installation

- 1. Mast/Platform Pin Mounts
- 2. Mast/Platform Lower Mount
- 3. Platform Latch Handle

6. Install the tool tray to the top of the platform rail.
 - a. Lower tray (1) onto the upper platform rails (2) at the front of the platform. Be certain the top cross rail is inserted into the rail slot under the rear of the tray and resting on the mast carry handle.
 - b. Once tray (1) is seated properly on the rails (2), secure to the front side rails using the two tray straps (3). Check that the tray is secure to the platform rails.
 - c. To remove, release the two tray straps (3) that secure the tray (1) to the platform rails (2) and lift the tray upward off of the platform rails. (See Figure 3-12.)

⚠ WARNING

THE WEIGHT OF OBJECTS CARRIED IN A PLATFORM TOOL TRAY, ALONG WITH PERSONNEL AND EQUIPMENT PLACED IN THE PLATFORM MUST NOT EXCEED THE MAXIMUM RATED PLATFORM CAPACITY. SEE TABLE 5-2.

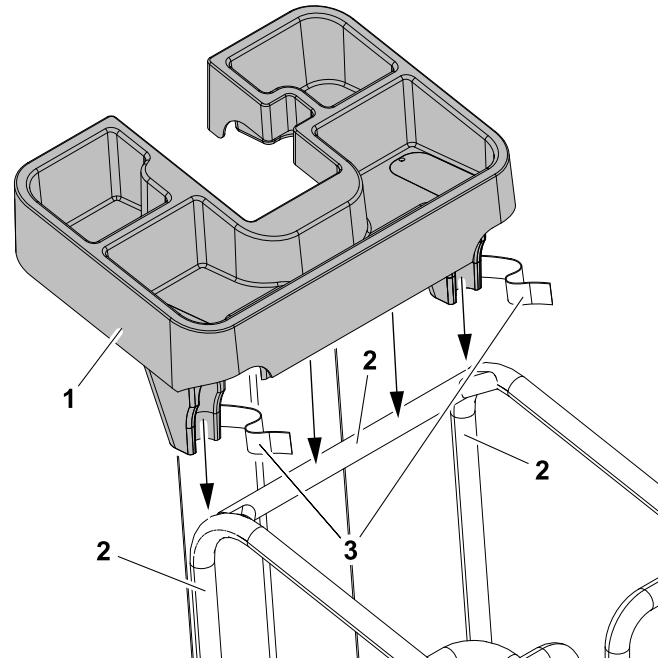

Figure 3-12. Tool Tray Installation

1. Tool Tray
2. Platform Front Top Rails
3. Tool Tray Straps

SECTION 3 - MACHINE OPERATION

Power Pack Control Unit Installation (Optional for FT70)

(See Figure 3-13. and Figure 3-14. for installation, also Section 3.6 on page 3-22 for complete description of PowerPack)

Before installing on machine, check battery charge indicator on control unit, be certain there is enough charge to complete your task.

POWER PACK CONTROL UNIT INSTALLATION

1. To install the Control Unit (1) onto the top of the mast; grasp with both hands and depress the latch handles (2) on each side of the Control Unit.
2. Place the Control Unit (1) onto the top of the mast assembly and align the driveshaft bit (hexagonal), lower down until it is fully seated on the mast top cap, release the latch handles on each side.

NOTE: (See Figure 3-14.) The FT140 machines use a Control Unit (1) for the FT70 mast assembly, and Drive Unit (2) for the FT140 mast assembly. It is recommended to install the FT140 mast Drive Unit first without the tool tray installed.

3. **FT140 - Power Pack configuration:**
Mount the Drive Unit and Control Unit same as step 1 and 2 above. Connect the Control Unit to the Drive Unit using the supplied connecting cable (item 4 - Figure 3-14.). Each end is connected with a twist-lock plug, push in and turn till tight.

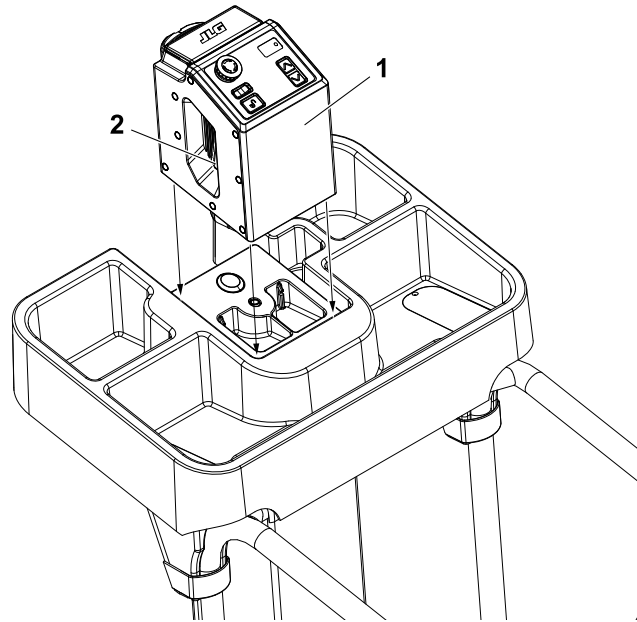

Figure 3-13. Powerpack Control Unit Installation (FT70)

1. Control Unit with Battery Attached
2. Latch/Release Handle - (1 each side)

NOTE: When reversing the procedure to disassemble the machine, grasp the Control or Drive Unit with both hands and depress the latch handles on both sides while lifting to disengage each unit from the top of the mast.

Machine Disassembly

Reverse the previous steps to disassemble the machine.

⚠ WARNING

DO NOT ATTEMPT TO LIFT THE MAST OFF THE BASE UNLESS THE MAST SECTIONS HAVE BEEN FULLY RETRACTED.

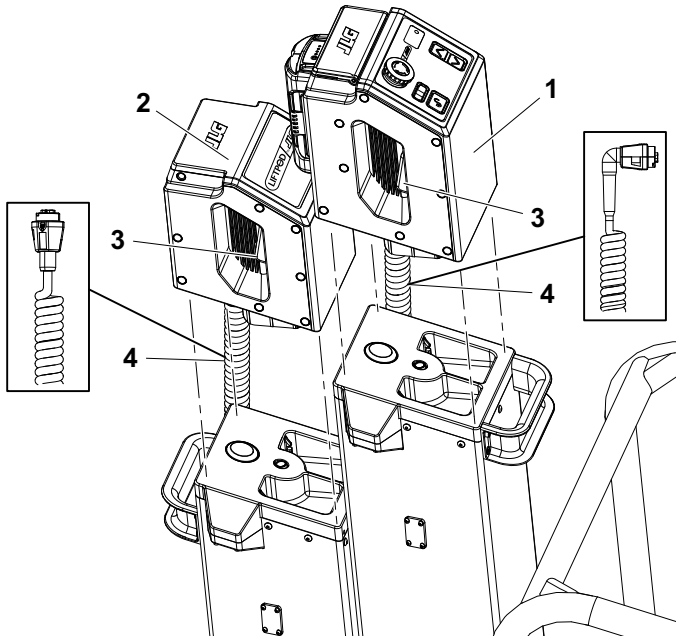

Figure 3-14. Powerpack Installation (FT140)

- | | |
|-----------------------------------|---|
| 1. FT Mast Control Unit w/Battery | 3. Latch/Release Handle (1 each side) |
| 2. FT140 Mast Drive Unit | 4. Control Unit to Drive Unit Power Cable |

SECTION 3 - MACHINE OPERATION

3.4 MACHINE OPERATION

The following control conditions must be met before elevating the platform:

- Make sure the pre-start inspection (Section 2) has been completed, the machine is safe to use, and the base is leveled.
- The mast driveshaft (hexagonal shape) must be inserted into the drive port at the top of the mast assembly if using a cordless drill or the manual descent tool.
- Whether operating with the powerpack or a heavy duty rechargeable cordless drill, the battery must contain enough power to operate the machine.
A low battery warning indicates the need to charge the battery. **The Battery should be fully charged prior to first use.**
- Emergency stop switch on the powerpack drive unit must be in the **RESET** position (out).
- Both platform swing-in entry gates must be closed once the operator is in the platform.

NOTICE

JLG RECOMMENDS THAT THE OPERATOR UTILIZES A FALL RESTRAINT SYSTEM IN THE PLATFORM WITH A MAXIMUM 36 INCH (91.4CM) LANYARD ATTACHED TO THE AUTHORIZED LANYARD ANCHORAGE POINT IN THE PLATFORM.

Positioning and Leveling Machine

1. Once assembled machine is positioned, it must be prevented from rolling by;

WARNING

FT70 ONLY - CRUSH HAZARD - KEEP FEET CLEAR OF ADJUSTABLE FEET AND UNDERNEATH BASE WHEN STEPPING ON BASE TO RETRACT CASTOR.

- a. **FT70** - Push down on the base frame's step plate until the front swivel castor retracts and the base sits on the adjustable feet at the front of the machine (See Figure 3-16.).
 - b. **FT140** - Set the brake on both front swivel caster wheels.
(See Figure 3-16.).
2. Adjust both front feet/caster wheels until the bubble level is centered and machine is level. (See Figure 3-15.)

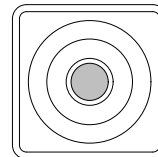

Level

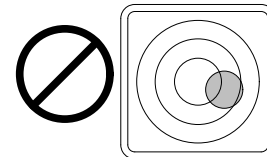

NOT - Level

Figure 3-15. Bubble Level Indicator - Machine Level

⚠ WARNING

DO NOT USE THE MACHINE IF THE BASE CAN NOT BE LEVELED ON A FIRM LEVEL SURFACE.

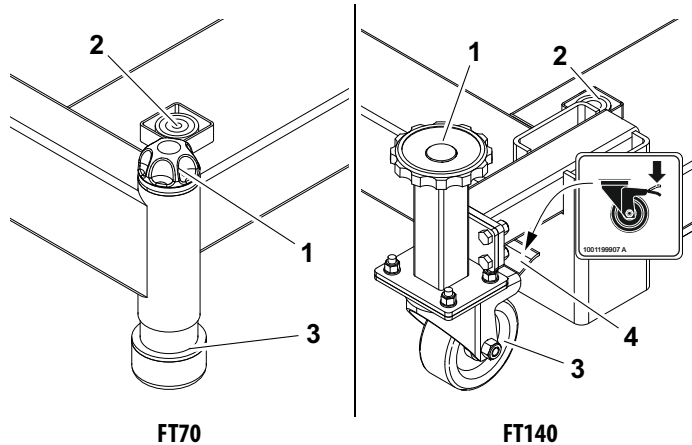

Figure 3-16. Base Leveling

- | | |
|---|------------------------------------|
| 1. Rotating Knob - Adjusts Foot/Caster Height - Up/Down | 3. Adjuster Foot/Caster Wheel |
| 2. Bubble Level Indicator | 4. Caster Wheel Brake - FT140 Only |

Entering/Exiting The Platform

⚠ WARNING

DO NOT EXCEED MAXIMUM PLATFORM CAPACITY. MAXIMUM CAPACITY INCLUDES PERSONNEL IN PLATFORM PLUS WEIGHT IN TOOL TRAY OR ANY OTHER WEIGHT PLACED IN PLATFORM.

1. Before entering platform, reach into platform below the entry gates and attach your harness lanyard to the platform lanyard attach point in the lower right-hand corner of the platform.
2. Grasp the platform side rails and step onto the step plate at the front of the base, then step into the platform through the platform gates.
3. Once in the platform and the entry gates have fully closed the platform is ready for operation.

⚠ WARNING

BEFORE OPERATING PLATFORM CHECK AROUND AND OVERHEAD FOR ANY OBSTACLES OR PERSONNEL THAT MAY COME INTO CONTACT WITH MACHINE WHILE ELEVATING OR LOWERING THE PLATFORM. IF NECESSARY, EXIT MACHINE AND REPOSITION BEFORE PROCEEDING.

4. Before exiting the platform, be certain platform is fully lowered.

SECTION 3 - MACHINE OPERATION

Platform Operation Using Cordless Drill

(See Figure 3-18. and Figure 3-17.)

Please follow the manufacturer's instructions on safe operation and maintenance of the cordless drill.

JLG recommends a cordless drill of at least 18V capacity.

If equipped, ensure cordless drill's "Hammer" setting is DISABLED and cordless drill is in "Drill" mode on medium to high torque. Do not set to maximum torque setting.

Stop using the cordless drill if any part of it becomes excessively hot. Wait until drill has cooled down and then continue operation.

WARNING

USE ONLY CORDLESS DRILLS. DISCONTINUE USE OF THE CORDLESS DRILL IF A FAULT IS DETECTED. ENSURE CORDLESS DRILL IS IN "DRILL" MODE ON MEDIUM TO HIGH TORQUE SETTING, BUT NOT MAXIMUM TORQUE SETTING TO AVOID INJURY.

WARNING

WHEN USING CORDLESS DRILL, THE DRILL LANYARD (ITEM 4 - FIGURE 3-18. ON PAGE 3-17) ONE END MUST BE ATTACHED TO THE UPPER MAST HANDLE AND THE OTHER ATTACHED TO THE DRILL BEFORE ELEVATING THE PLATFORM. DO NOT DROP DRILL.

Elevating/Lowering Platform (See Figure 3-18. on page 3-17)

1. When using a cordless drill (1) to elevate/lower platform; fasten one end of the supplied lanyard (4) attached to the upper mast handle and the other end secured around the handle of the cordless drill.
2. When ready, slide the cordless drill with the hex drive bit installed into the hex shaped drive port on the top of the mast. The hexagonal shaped drive bit is stored in the platform manual pouch.
3. Firmly grasp drill, press down to engage drive bit into driveshaft and apply power to operate the platform;
 - a. Clockwise drill operation will elevate the platform;
 - b. Counterclockwise drill operation will lower the platform;
 - c. Releasing drill power trigger will stop all platform movement.
 - d. When reaching full mast extension or retraction, an internal slip-clutch within the mast assembly will stop all mast movement.

WARNING

CRUSHING HAZARD - BE AWARE OF DESCENDING PLATFORM WHEN LOWERING THE PLATFORM. KEEP HANDS OR FEET OFF THE MAST ASSEMBLY AND FROM BENEATH PLATFORM.

NOTICE

ENGAGING THE MAST INTERNAL SLIP-CLUTCH FOR EXTENDED PERIODS WILL REDUCE THE LIFE OF THE SLIP-CLUTCH REQUIRING EARLY REPLACEMENT.

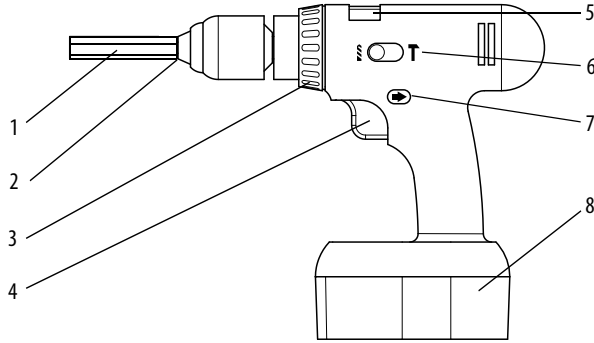

Figure 3-17. Typical Cordless Drill Controls

1. Hexagonal Drive Shaft Bit (Stored in Manual Pouch)
2. Chuck
3. Torque Control (if equipped)
4. Power Trigger
5. Speed Controller (if equipped)
6. Drill/Hammer Function Selector (if equipped)
7. Direction Selector
8. Battery Pack

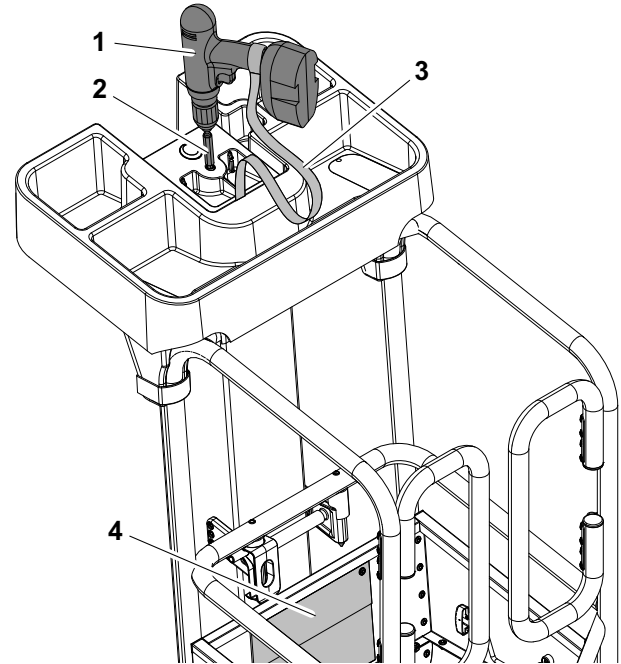

Figure 3-18. Cordless Drill Operation

- | | |
|----------------------|--|
| 1. Cordless Drill | 3. Drill Lanyard (Attach to mast handle) |
| 2. Hexagon Drive Bit | 4. Machine Manual Pouch |

Platform Operation Using The Power Pack Control Unit

⚠ WARNING

CRUSHING HAZARD - BE AWARE OF DESCENDING PLATFORM WHEN LOWERING THE PLATFORM. KEEP HANDS OR FEET OFF THE MAST ASSEMBLY AND FROM BENEATH PLATFORM.

1. Power up the Control Unit, if the emergency stop/shutdown button is pressed in (activated), turn it clockwise till it pops out. The powerpack will switch on. If battery power is sufficient, the LED power indicator should be lit up GREEN.

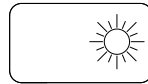
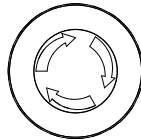

2. Select which mast to operate with the mast selector button, the FT70 mast or the FT140 mast drive unit.

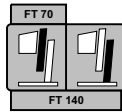
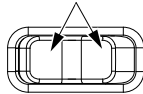

3. Press and hold the Function Enable button and then press the Up or Down button to move the platform up or down.

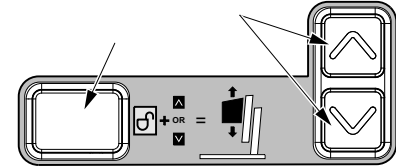

The Enable button times out after 5 seconds if no buttons are pressed, press Enable again to activate.

Platform Operation Using Manual Descent Tool

For emergency operation please see Section 4 - Emergency Procedures.

The platform manual descent crank (*Figure 4-1. on page 4-2*) is provided to:

- Allow the platform operator to lower the platform in the event that the cordless drill or powerpack batteries run out of sufficient charge to lower the platform;

The base mounted manual descent tool (*Figure 4-2. on page 4-3*) is provided to:

- Allow ground personnel to lower the platform in event that the platform operator becomes incapacitated.

3.5 TRANSPORT AND MANEUVERING (MOVING)

General

The machine may be manually maneuvered or transported in a vehicle disassembled.

WARNING

DO NOT ATTEMPT TO TRANSPORT OR MOVE MACHINE UNLESS THE MAST IS FULLY LOWERED. DO NOT MOVE MACHINE WITH PERSONNEL IN PLATFORM.

The machine may be moved around a worksite using the following methods:

- Fully assembled, pushed around the floor using the wheels and castor(s);
- Disassembled, with each major component carried separately.

CAUTION

WHEN PUSHED AROUND, ONLY ATTEMPT TO MOVE THE MACHINE ON A FLAT AND LEVEL SURFACE. ENSURE A FIRM GRIP WITH TWO HANDS ON THE MACHINE.

Fully Assembled Maneuvering

FT70 and FT140 assembled machine:

WARNING

DO NOT ATTEMPT TO TRANSPORT OR MOVE MACHINE UNLESS THE MAST IS FULLY LOWERED. DO NOT MOVE MACHINE WITH PERSONNEL IN PLATFORM.

The machine can be pushed around using the built-in rear wheels and front castor wheel(s). Only attempt to move the machine on a flat and level surface, ensure a firm grip with two hands on the machine.

Pushing Machine Around

Push machine around from the platform end of the machine. While grasping the platform side rails with the swivel casters at your feet and the mast end leading the way. This will give you the most control of the machine.

NOTE: *While the FT70 and FT140 can both be moved around by pushing, only the FT70 is narrow enough to fit through most standard doorways.*

NOTE: *Ensure powerpack and tool tray are securely attached and tool tray and platform are empty before moving.*

SECTION 3 - MACHINE OPERATION

FT70 Only - There can be no significant load on the machine while it is being rolled around, or the swivel castor will retract automatically.

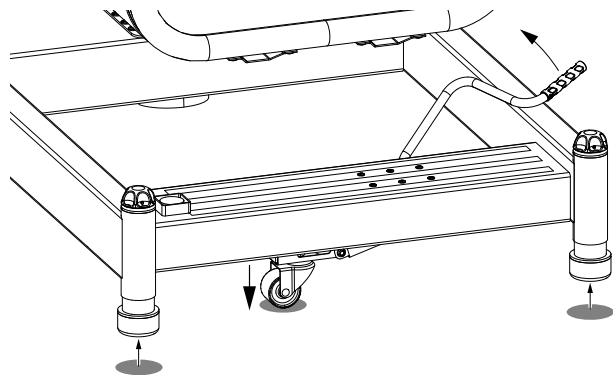

Figure 3-19. FT70 - Lift the handle to extend the swivel castor

FT70 Model

1. Lift the handle to engage the swivel castor. (See Figure 3-19.)
2. Once the swivel is locked in the down position, the machine can be positioned as required.

FT140 Model

1. Check that the brake on both front swivel castor wheels are released. Once released the wheels will roll freely.

Disassembled Maneuvering

The machine is designed to be used and assembled on the worksite. To improve portability, it is divided into a number of self contained sub-assemblies. (See Figure 3-1. - FT70 or Figure 3-2. - FT140).

⚠ WARNING

TAKE PRECAUTIONS TO AVOID MANUAL HANDLING INJURIES. USE PROPER LIFTING TECHNIQUES: BEND AT KNEES ONLY, NEVER TWIST YOUR BACK WHEN HOLDING OR CARRYING A LOAD, AND/OR GET HELP. ONLY CARRY ONE COMPONENT AT A TIME.

FT140 MAST ASSEMBLY - JLG RECOMMENDS TWO (2) PEOPLE LIFT ON AND OFF MACHINE.

The mast assembly can be carried by the built-in handles (see Figure 3-6.).

Parking and Storage

- Move machine to a dry, well-protected and well-ventilated area out of direct sunlight.
- Ensure the platform is fully lowered. If installed, move the powerpack's emergency stop/shut-down switch to the **set (OFF)** position.
- If necessary, remove the cordless drill or optional powerpack from the platform to prevent unauthorized use.
- **(FT70)** - Ensure the swivel castor is retracted and the machine is resting on the adjustable feet.
(FT140) - Set one or both caster wheel brake(s).

NOTICE

DO NOT STORE IN LOCATIONS WHERE THE MACHINE MAY ACCUMULATE ICE, GREASE OR AIRBOURNE DEBRIS.

Vehicle Transport

When transporting the machine by vehicle, it should be disassembled into its major components (*see Figure 3-1. and Figure 3-2.*). Restrain each component of the machine securely during transport.

FT70 Model: Ensure the swivel castor is retracted into the base frame.

NOTICE

USE OF EXCESSIVE FORCE WHEN SECURING MACHINE CAN CAUSE DAMAGE TO THE MACHINE.

Secure machine to the transport vehicle with adequately rated rope or straps. Do not overtension such devices and place a buffer between the device and any part of the machine.

3.6 POWER PACK (OPTIONAL FOR FT70)

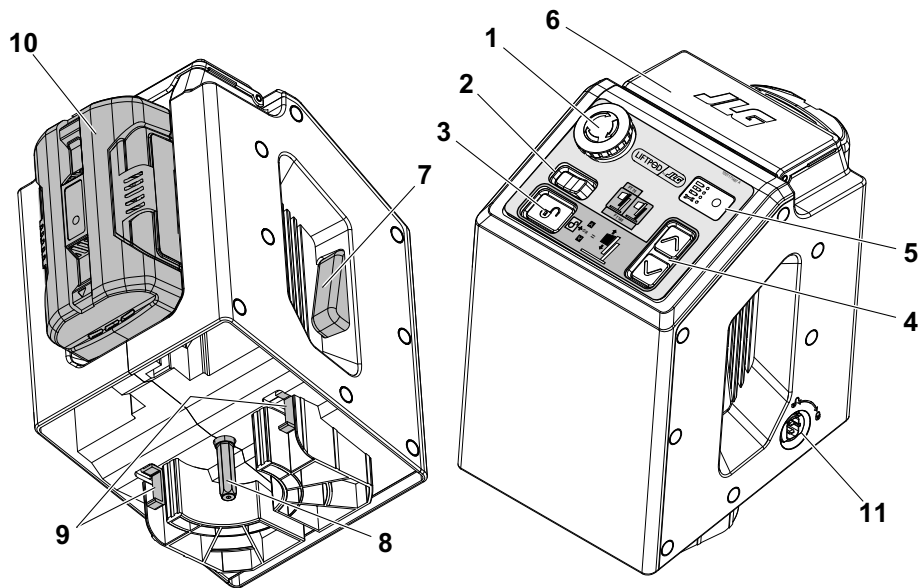

Control Unit

1. Emergency Stop/Shut-down Button
2. Mast Select Button
3. Function Enable Button
4. Platform UP/DOWN Buttons
5. Battery Status LED Indicator
6. Battery Cover
7. Latch Release Handles (1 each side)
8. Power Pack Driveshaft
9. Latch Locking Tabs
10. Lithium-Ion Battery - Removable
11. Connection Port for FT140 Drive Unit.

NOTE: The FT140 Drive Unit contains only a drive motor and no controls. It is powered and controlled through the connection port (11) by the battery on the Control Unit.

Figure 3-20. Power Pack Controller Components - (FT70) (Option)

Emergency Stop/Shutdown Button

(Item 1 - Figure 3-20.)

If the platform stops responding to operator input at any time while the platform is moving, press the emergency stop button to cut the power to the motor.

This button can also be used to turn the power pack off when not use.

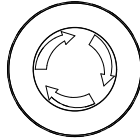

Mast Select Button

(Item 2 - Figure 3-20.)

This rocker type button selects which drive motor the Control Unit will supply power to, depending on the machine configuration. As shown on decal next to switch, when rocker is depressed to the left the FT70 Control Unit is controlled, when depressed to the right the FT140 Drive Unit is controlled.

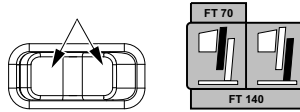

Function Enable Button

(Item 3 - Figure 3-20.)

The function enable button must be pressed and held during operation of the platform UP/DOWN buttons. The Enable button times out after 5 seconds if no buttons are pressed, press enable button again to activate.

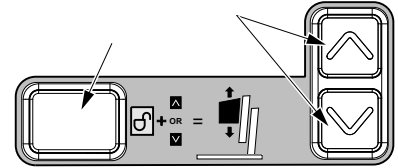

Platform UP/DOWN Buttons

(Item 4 - Figure 3-20.)

The UP arrow raises the platform and the DOWN arrow lowers the platform. Press and hold the Function Enable button when operating the platform UP/DOWN buttons.

Battery Status LED Indicator

(Item 5 - Figure 3-20.)

This LED indicator shows the battery status when the machine is powered up and during operation.

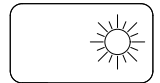

- GREEN light indicates READY (good battery charge)
- FLASHING GREEN indicates (low battery charge)

SECTION 3 - MACHINE OPERATION

- FLASHING RED indicates (platform down operation only)
- RED indicates (power pack needs serviced or wrong operation)

Latch Release Handles (1 each side)

(Item 7 - Figure 3-20.)

These handles are used when attaching or removing the Control/Drive Units from the machine. Press both latches on each side when attaching or removing. When the unit is seated on top of the mast, the latch tabs on the bottom of the power pack engage slots in the mast cap.

Control Unit/Drive Unit Driveshaft

(Item 8 - Figure 3-20.)

This hexagonal steel shaft on the bottom of the unit is inserted into the drive gear receptacle in the mast cap. When the drive motor is energized, the driveshaft turns the gear mechanism to extend or retract the mast sections.

Latch Locking Tabs

(Item 9 - Figure 3-20.)

When properly installed these tabs engage the notches in the mast cap guides to secure the unit to the top of the mast during operation. They are retracted when the latch release handles are depressed for removal of the power pack.

Lithium-Ion Battery

(Item 10 - Figure 3-20.)

This removable battery provides the energy for both the Control Unit and Drive Unit drive motors to raise and lower the platform.

Connection Port for FT140 Drive Unit

(Item 11 - Figure 3-20.)

This port is for connection of the Control Unit and the Drive Unit through supplied electrical cable. When the Mast Select Button is set to FT140, control and battery power is provided through this cable to the FT140 drive unit.

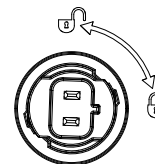

⚠ WARNING

DISCONTINUE USE OF THE POWERPACK IF A FAULT IS DETECTED.

NOTICE

DO NOT PRESSURE-WASH THE POWERPACK OR DRIVE UNIT.

Battery Operation

⚠ WARNING

DO NOT SHORT CIRCUIT THE BATTERY. DO NOT OPEN THE BATTERY PACK AS THERE IS A DANGER OF CAUSING A SHORT CIRCUIT. PROTECT THE BATTERY AGAINST HEAT, INCLUDING AGAINST CONTINUOUS DIRECT SUN EXPOSURE OR OPEN FLAME.

New batteries and batteries that have not been used for a long period must be fully charged. They will not reach their full capacity until fully charged and discharged through several cycles. Battery performance will be limited at low temperatures. The battery can be charged and discharged hundreds of times but will eventually wear out and need to be replaced. A significantly reduced operating period after charging indicates that the battery must be replaced.

NOTICE

CHECK THE REMAINING CHARGE INSIDE THE POWERPACK'S BATTERY BEFORE ELEVATING THE PLATFORM BY PRESSING THE CHARGE STATUS INDICATOR BUTTON ON THE BATTERY. IF ONLY ONE LED COMES ON, EITHER CHARGE THE BATTERY, OR REPLACE WITH FULLY CHARGED BATTERY.

Removing Battery From Power Pack Control Unit

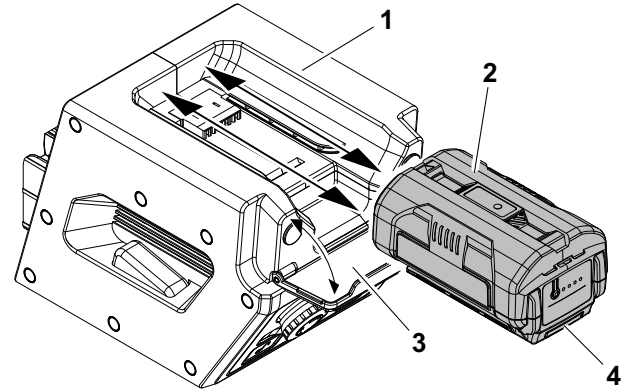

Figure 3-21. Battery Removal - Powerpack Control Unit

1. Power Pack Control Unit lying face down
2. Battery Pack
3. Battery Cover opened out of the way.
4. Battery Release Latch (Press to Remove Battery)

Battery Charge Status Lights

The powerpack batteries charge status LEDs, indicate battery discharge levels. Pressing the charge status button (1) will light up the charge LED which will indicate the battery charge level.

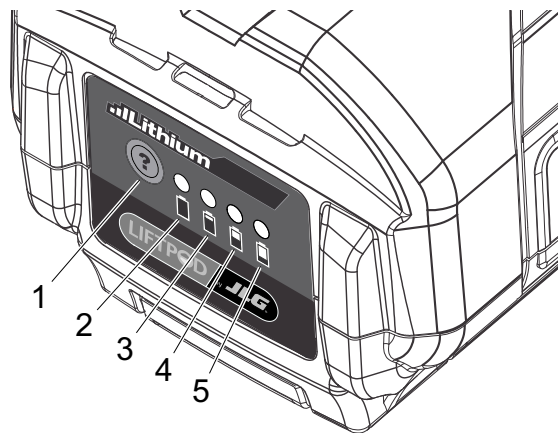

Figure 3-22. Charge status lights

- | | |
|-----------------------------------|-------------------|
| 1. Charge Status Indicator Button | 4. 1/2 Charge LED |
| 2. Full Charge LED | 5. 1/4 Charge LED |
| 3. 3/4 Charge LED | |

SECTION 4. EMERGENCY PROCEDURES

4.1 GENERAL INFORMATION

This section explains the steps to be taken in case of an emergency situation during operation.

Manual Descent Tool

The platform manual descent tool (*See Figure 4-1.*) is provided to:

- Allow the platform operator to lower the platform in the event that the cordless drill or powerpack batteries run out of sufficient charge to lower the platform.

The ground manual descent tool (*See Figure 4-2.*) is provided to:

- Allow ground personnel to lower the platform in the event that the platform operator cannot lower the platform once elevated.

NOTICE

THE TOOL IS DESIGNED FOR DESCENT IN CASE OF LOSS OF POWER ONLY. IT MUST NOT BE USED TO ELEVATE THE PLATFORM OR FOR GENERAL OPERATIONS.

WARNING

IF THE BATTERIES ARE DISCHARGED WHILE THE UNIT IS ELEVATED, DO NOT CLIMB OUT OF THE PLATFORM. USE THE MANUAL DESCENT TOOL TO LOWER THE PLATFORM.

Platform - Manual Descent Tool Operation

(See Figure 4-1.)

If the battery should run out of charge before the platform has fully descended:

1. Remove the cordless drill and hexagonal drive bit at the top of the mast and place it elsewhere in the platform or tool tray.
If the optional powerpack is installed, remove it and place it elsewhere in the platform or tool tray.
2. Remove the manual descent crank (1) from the mounting clips inside the platform.
3. Engage the hexagon drive bit on the end of the manual descent crank with the hexagon drive gear port at the top of the mast (2).
4. Push down on top of the handle to engage the drive gear and turn the crank counter-clockwise until the platform is fully lowered.

NOTE: *FT140 machine*, if both masts are extended, you will only be able to reach the upper (FT70) mast first, once that is fully lowered move the manual descent tool to the (FT140) mast and lower it until mast is fully retracted before exiting platform.

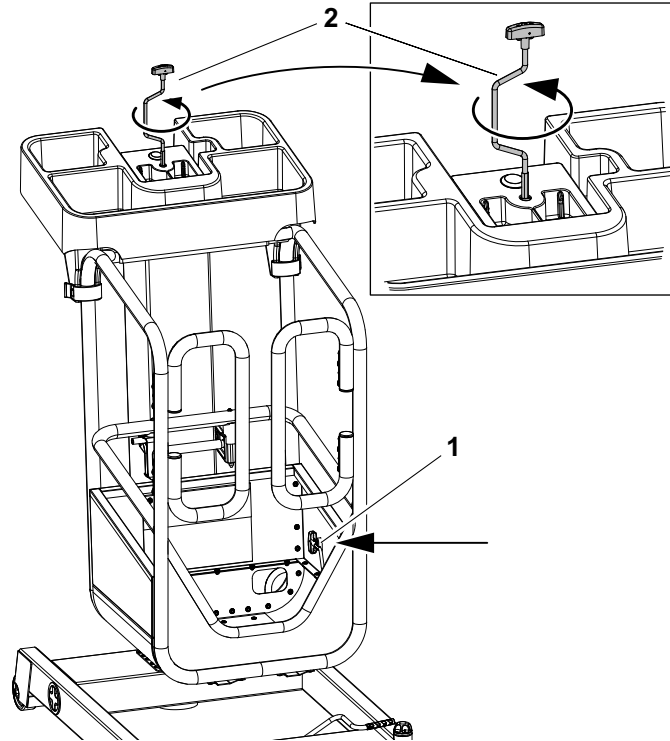

Figure 4-1. Platform - Manual Descent Tool Operation

Ground - Manual Descent Tool Operation

(See Figure 4-2.)

If the platform operator is pinned, trapped or unable to operate or control the machine, other personnel should operate the machine from the ground using the telescoping manual descent tool mounted in the base frame.

1. Locate the manual descent tool (1) on the right side of the base frame. Turn the manual descent tool handle counter-clockwise and slide the tool out of the base frame.
2. Extend the tool (2) as needed to reach the mast auxiliary driveshaft port on the right rear underside of the mast.
3. Once the tool is inserted into the aux drive port (3) on the mast, turn the descent tool (4) counter-clockwise until the platform is fully lowered. The handle on the descent tool is equipped with a hex slot to allow the use of the platform manual descent crank, if available.

NOTE: *FT140 machine*, if both masts are fully extended, you will only be able to reach the lower (FT140) mast first, once that is lowered, then lower the upper (FT70) mast.

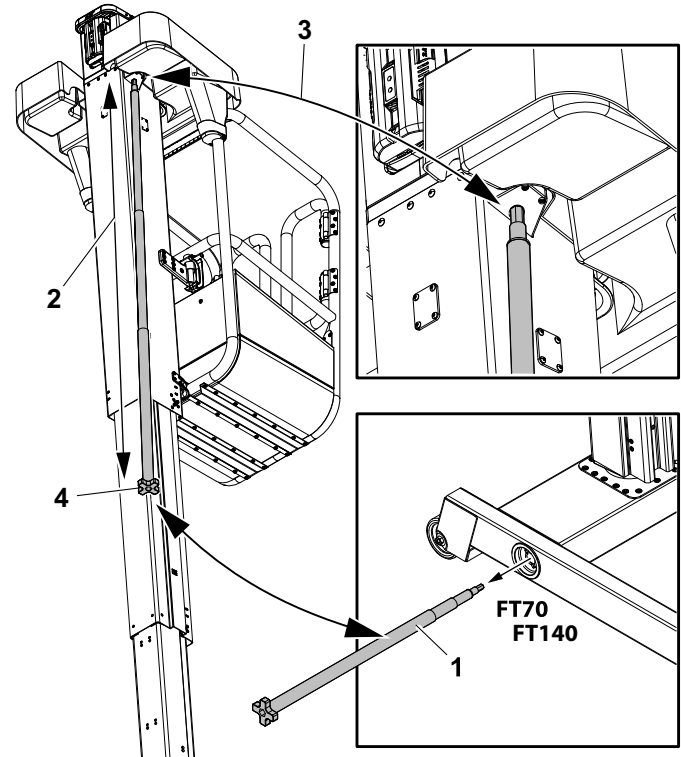

Figure 4-2. Ground - Manual Descent Tool Operation

Platform Caught Overhead

If the platform becomes jammed or snagged in overhead structures or equipment, rescue the platform occupant prior to freeing the machine.

Rescue equipment can be used to remove the platform occupant. Cranes and forklifts can be used to stabilize motion of the machine.

Operator Elevated In Platform - Platform Will Not Lower

If the operator or ground personnel cannot fully lower the platform call for help. The operator should then be safely removed from the platform using suitable equipment.

WARNING

DO NOT CLIMB OUT OF THE PLATFORM WHILE ELEVATED. THIS MAY AFFECT THE MACHINE'S BALANCE, CAUSING IT TO TIP OVER. ONLY EXIT THE PLATFORM VIA THE PLATFORM GATES. DO NOT ATTEMPT TO CLIMB DOWN MAST.

4.2 INCIDENT NOTIFICATION

JLG Industries, Inc. must be notified immediately of any incident involving a JLG product. Even if no injury or property damage is evident, JLG must be contacted by telephone and provided with all necessary details.

- USA: 877-JLG-SAFE (554-7233)
- EUROPE: (32) 0 89 84 82 20
- AUSTRALIA: (61) 2 65 811111
- E-mail: productsafety@jlg.com

Failure to notify the manufacturer of an incident involving a JLG Industries product within 48 hours of such an occurrence may void any warranty consideration on that particular machine.

NOTICE

FOLLOWING ANY INCIDENT, THOROUGHLY INSPECT THE MACHINE. DO NOT ELEVATE THE PLATFORM UNTIL IT IS CERTAIN THAT ALL DAMAGE HAS BEEN REPAIRED AND THAT ALL CONTROLS ARE OPERATING CORRECTLY. TEST ALL FUNCTIONS FIRST FROM THE GROUND CONTROL STATION THEN FROM THE PLATFORM CONTROL CONSOLE.

SECTION 5. GENERAL SPECIFICATIONS

5.1 INTRODUCTION

This section of the manual provides operating specifications and information necessary for proper maintenance of this machine.

5.2 GENERAL SPECIFICATIONS

SPECIFICATION	FT70	FT140
Gross Machine Weight: <i>(without optional tool tray or power-pack)</i>	208 lb. (94.5 kg)	314.6 lb. (142.7 kg)
Machine Height: <i>(platform stowed)</i>	5 ft. 5 in. (1.64 m)	6 ft. 7 in. (1.99 m)
Platform Step-In Height:	11.6 in. (0.3 m)	17.7 in. (0.45 m)
Maximum Platform Floor Height: <i>(mast extended)</i>	7 ft. 1 in. (2.16 m)	13 ft. 6 in. (4.11 m)
Maximum Working Height: <i>(average person height)</i>	13 ft. 1 in. (3.99 m)	19 ft. 6 in. (5.94 m)
Machine Overall Footprint:	44.3 in x 29.9 in (1,126 mm x 760 mm)	58.3 in. x 64.4 in. (1,480 mm x 1,635 mm)
Leveling Capability <i>(Front to Back)</i>	2°	2°
Maximum Wind Speed Operation:	0 mph (0 kph) - Machine rated for indoor use only.	

Table 5-1. Machine Specifications

SECTION 5 - GENERAL SPECIFICATIONS

Platform Data

SPECIFICATION		FT70/FT140
Occupants: <i>(Persons allowed in Platform)</i>		1
Platform Capacity:	ANSI/C.S.A.:	330 lb. (150kg)
Platform Capacity: <i>(with Tool Tray at Maximum Capacity)</i>	ANSI/C.S.A.:	297 lb. (135kg)
Tool Tray Capacity: (Max.)	ANSI/C.S.A.:	33 lb. (15 Kg)

Table 5-2. Platform Data

Optional Powerpack Electrical Specifications

DESCRIPTION		SPECIFICATION
Battery Specifications:	Battery Type	Lithium Ion
	Voltage	40 Volts DC
	Amp Hour (AH) Rating	2.6 Ah
	Weight	3.1 lb. (1.81 kg)
Nominal Duty Cycle at Rated Capacity:	FT70:	20 complete cycles
<i>(Full Charge/Normal Operating Temps)</i>	FT140:	8 complete cycles
Battery Fast Charger:	Input:	120 Volts AC - 60 Hz
	Output:	40 Volts DC - w/Auto Charge Sensing Circuit
Approvals:		UL, cUL
Operating Noise Level		70 dba

Table 5-3. Optional Powerpack Electrical Specifications

Machine Component Weights

SPECIFICATION	WEIGHT
Base Frame - FT70	55 lb. (25.1 kg)
Base Frame - FT140	62.41 lb. (28.3 kg)
Mast - FT70	71 lb. (32.3 kg)
Mast - FT140	78 lb. (35.3 kg)
Mast - FT70 and Ft140 Combined	149 lb. (67.6 kg)
Mast Mount (Stump) - FT70	45 lb. (20.3 kg)
Mast Mount (Stump) - FT140	43.4 lb. (19.7 kg)
Platform with Tool Tray	37 lb. (16.8 kg)
Powerpack Control Unit (including battery)	10.2 lb. (4.6 kg)
Powerpack Drive Unit	5.7 lb. (2.6 kg)

Table 5-4. Machine Component Weights

Serial Number Locations

For machine component identification, serial number barcode decals are affixed to the various modules. The barcodes are located as indicated in Figure 5-1. to Figure 5-7.

5.3 DECAL REPLACEMENT

All decals must be mounted to the machine as specified and be clearly legible.

Please see Figure 5-1. thru Figure 5-10. and refer to Table 5-5. for positions and JLG part numbers.

To replace a damaged decal, first remove it completely, without damaging the underlying surface.

Remove any remaining adhesive with a suitable solvent. Test solvent on inconspicuous area first, to ensure it does not mark or damage the underlying surface finish.

NOTICE

SURFACE DAMAGE COULD RESULT IN CORROSION AND STRUCTURAL DAMAGE.

Before applying new decal, ensure the surface is clean and dry. Remove backing paper, apply decal along one edge then seat it gently and evenly.

If there are any air bubbles, work them gently towards the edge with a clean cloth.

The decal pressure sensitive adhesive reaches full strength several days after installation.

5.4 DECAL INSTALLATION

Table 5-5. Decal Descriptions.

No.	Description	English	French (CSA)	Spanish	Brazilian Portuguese	Chinese
Decal Installation, BASE, FT70 (Figure 5-1. on page 5-9)		1001152379-B	1001211093-A	1001211081-A	1001211087-A	1001231945-A
1	General Brand	1001070281				
2	Crushing Hazard	1001160347	1001203139	1001200952	1001201010	1001231206
3	FT70 - Max Wheel Load	1001160348	1001203140	1001200953	1001201011	1001231207
4	Base Crush Hazard	1001160350	1001203141	1001200954	1001201012	1001231208
5	LiftPod by JLG	1001160351				
6	Manual Descent Crank Location	1001164925 - FT70				
7	Bubble Level	1001188099	1001203142	1001200955	1001201013	1001231213
8	Serial Number Tag (Location Only)	—				
Decal Installation, BASE, 140FT (Figure 5-2. on page 5-10)		1001165758-B	1001211095-A	1001211083-A	1001211089-A	1001232012-A
1	General Brand	1001070281				
2	Crushing Hazard	1001160347	1001203139	1001200952	1001201010	1001231206
3	FT140 - Max Wheel Load	1001160348	1001203140	1001200953	1001201011	1001231207
4	LiftPod by JLG	1001160351				
5	Manual Descent Crank Location	1001168145 - FT140				
6	Bubble Level	1001188099	1001203142	1001200955	1001201013	1001231213
7	Caster Lock	1001199907				

SECTION 5 - GENERAL SPECIFICATIONS

Table 5-5. Decal Descriptions.

No.	Description	English	French (CSA)	Spanish	Brazilian Portuguese	Chinese
8	Serial Number Tag (Location Only)	—				
Decal Installation, MAST, FT70 (Figure 5-3. on page 5-11)		1001152422-B	1001211094-A	1001211082-A	1001211088-A	1001231349-A
1	General Brand	1001070281				
2	Summary	1001158822	1001203143	1001200956	1001201014	1001231203
3	Electrocution	1001158823	1001203144	1001200957	1001201015	1001231215
4	Capacity	1001158825	1001203145	1001200958	1001201016	1001231204
5	FT Quick Start Guide	1001160767	1001203146	1001200959	1001201017	1001160767
6	FT70 - Mast Branding	1001160769				
7	Manual Descent Crank Instructions	1001165390	1001203147	1001200960	1001201018	1001231210
8	ANSI Warning Label	1001173630	1001203148	1001200961	1001201019	1001231212
9	Two Person Lift	1001187424				
10	Serial Number Tag (Location Only)	—				
Decal Installation, MAST, FT140 (Figure 5-4. on page 5-12)		1001164959-B	1001211096-A	1001211084-A	1001211090-A	1001231968-A
1	General Branding	1001070281				
2	Manual Descent Crank Instruction	1001165390	1001203147	1001200960	1001201018	1001231210
3	FT140 Mast Branding	1001168146				
4	ANSI Warning Label	1001173630	1001203147	1001200961	1001201019	1001231212
5	ISO Two Person Lift	1001187424				

Table 5-5. Decal Descriptions.

No.	Description	English	French (CSA)	Spanish	Brazilian Portuguese	Chinese
6	Pinch Point	1706302	1001203149	1001200963	1001201020	1001231202
7	Serial Number Tag (Location Only)	—				
Decal Installation, PLATFORM (Figure 5-5. on page 5-13)		1001152154-B	1001211092-A	1001211080-A	1001211086-A	1001152154-B
1	Manual Decal	1701509				
2	Lanyard Location/Length	1001158824	1001203138	1001200951	1001201009	1001158824
3	LiftPod by JLG	1001160351				
4	Platform Latch Release	1001164926				
5	JLG Logo-2-3/4 inch	1001190969				
6	Serial Number Tag (Location Only)	—				
Decal Installation, Tool Tray (Figure 5-6. on page 5-14)		1001192760-B	1001211097-A	1001211085-A	1001211091-A	1001231889-A
1	Tool Tray Capacity/Object Hazard	1001192409	1001203150	1001200964	1001201021	1001231209
2	Cordless Drill Instructions	1001164635	1001203151	1001200965	1001201023	1001231214
3	Prop 65	1001231801	—			
Decal Installation, CONTROL UNIT (Figure 5-7. on page 5-15)		1001171988-B				
1	Controls Decal	1001171487				
Decal Installation, DRIVE UNIT (Figure 5-8. on page 5-16)		1001173194-C				

SECTION 5 - GENERAL SPECIFICATIONS

Table 5-5. Decal Descriptions.

No.	Description	English	French (CSA)	Spanish	Brazilian Portuguese	Chinese
1	Power Pack			1001173120		
Decal Installation, BATTERY PACK (Figure 5-9. on page 5-17)			1001232013-A			
1	Battery Warning - 2.6 Ah Battery Battery Warning - 4.0 Ah Battery		1001171486 1001213954			
2	Battery Charge			1001171490		
3	General Brand			1001171637		
4	Battery Side - 2.6 Ah Battery Battery Side - 4.0 Ah Battery		1001186557 1001214019			
Decal Installation, BATTERY CHARGER (Figure 5-10. on page 5-18)			1001171990-B			1001227513-A
1	Charger Rating Label			1001171638		
2	Charger Center Label			1001171639		
3	General Brand			1001172156		
4	Charger Warning Label			1001186252		

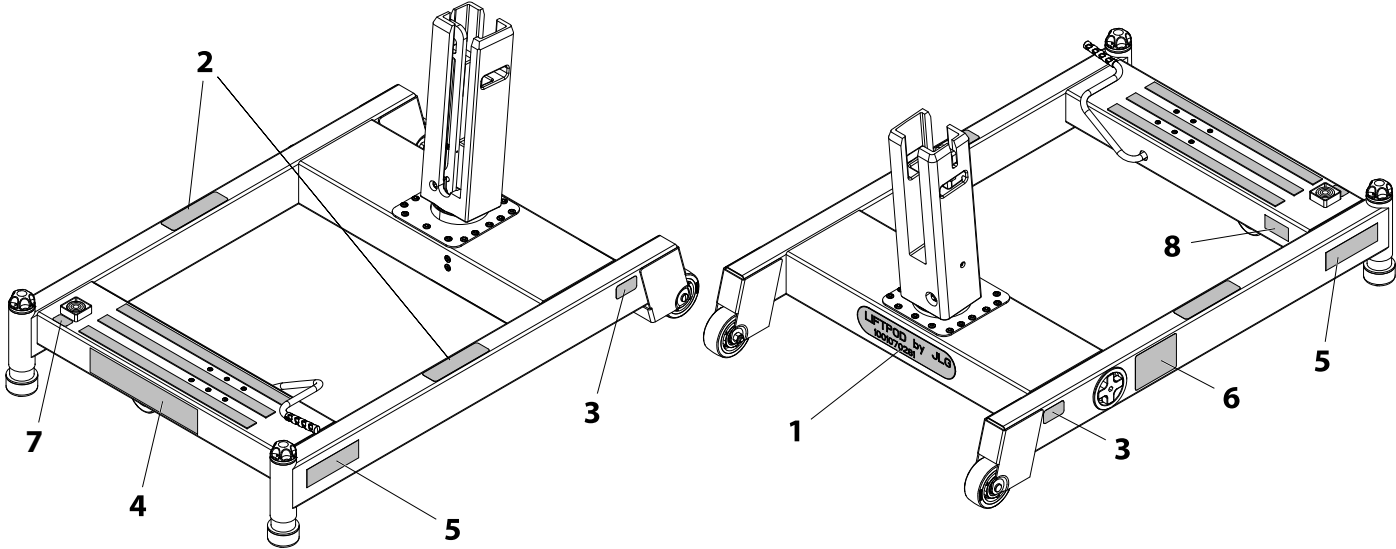

Figure 5-1. Base Decal Installation - FT70

SECTION 5 - GENERAL SPECIFICATIONS

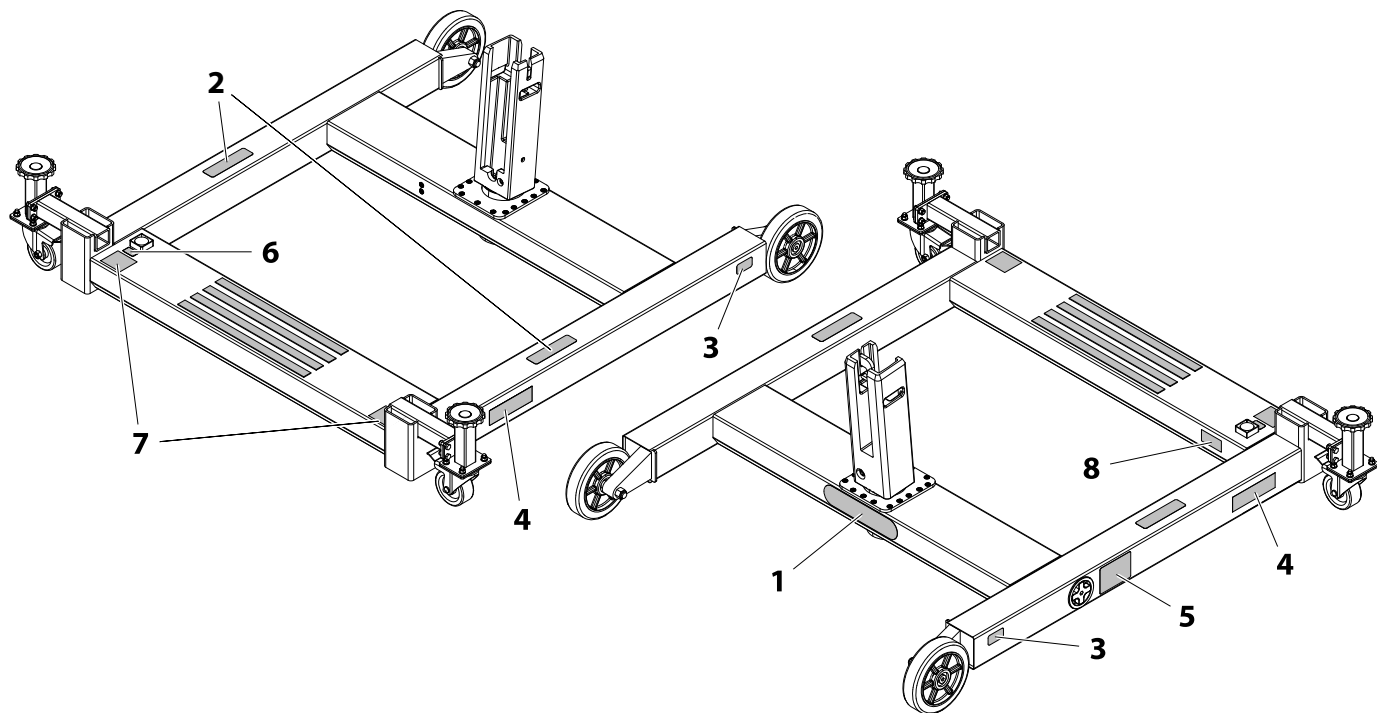

Figure 5-2. Base Decal Installation - FT140

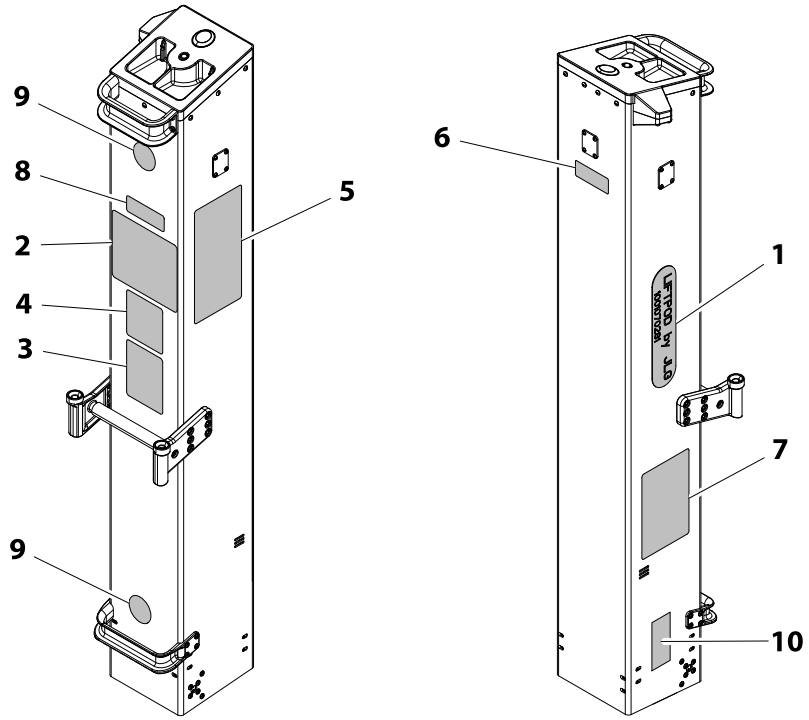

Figure 5-3. Mast Decal Installation - FT70

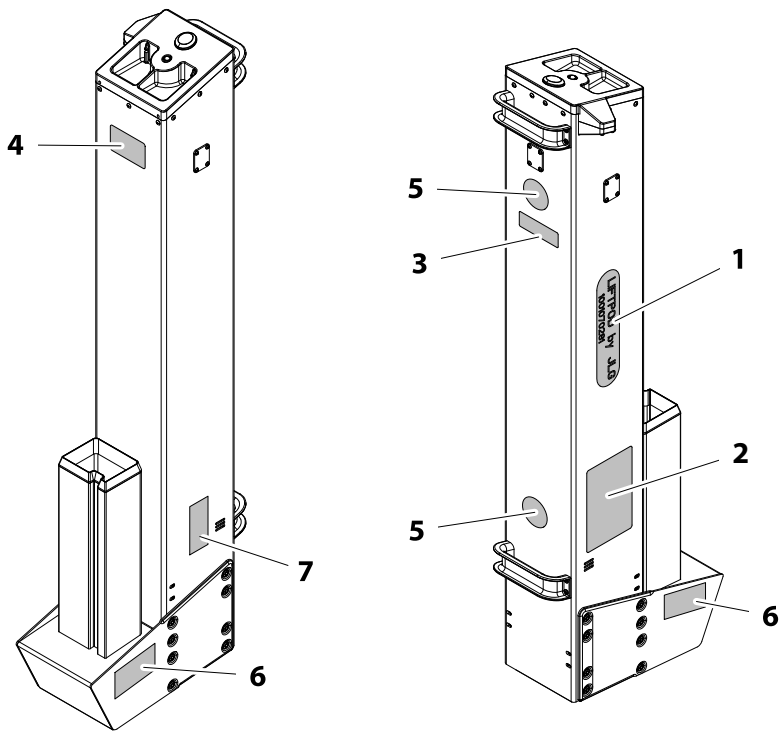

Figure 5-4. Mast Decal Installation - FT140

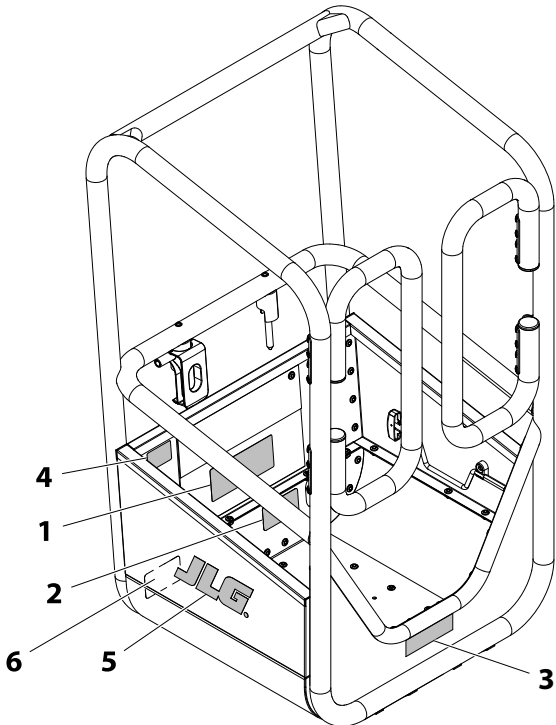

Figure 5-5. Platform Decal Installation

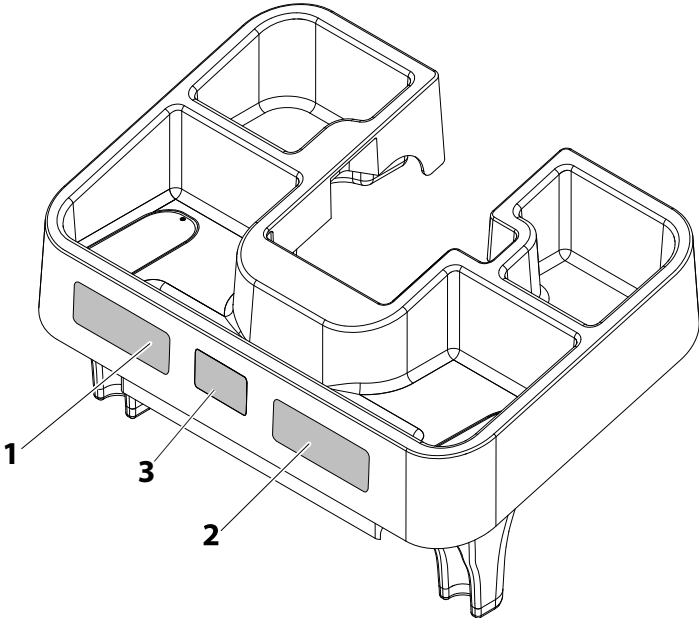

Figure 5-6. Tool Tray - Decal Installation

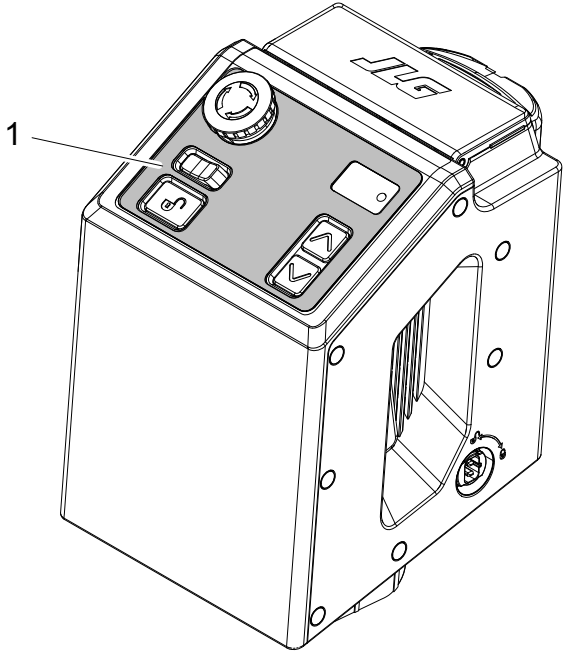

Figure 5-7. Power Pack Control Unit - Decal Installation

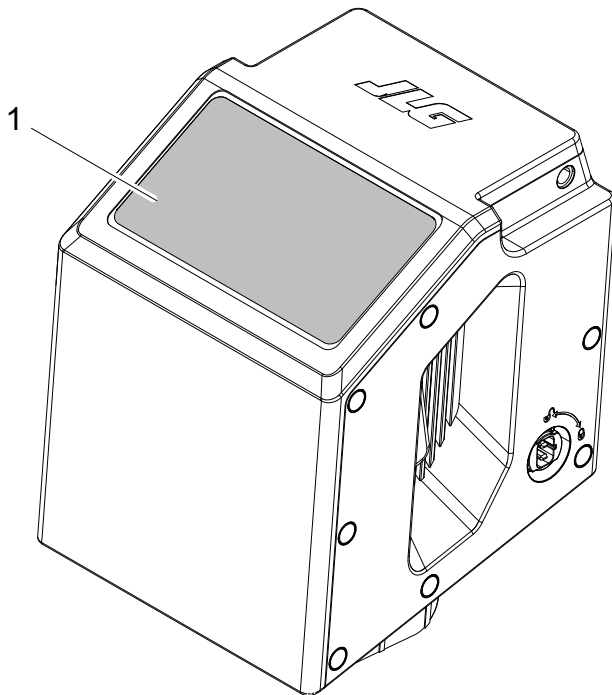

Figure 5-8. Power Pack Drive Unit - Decal Installation

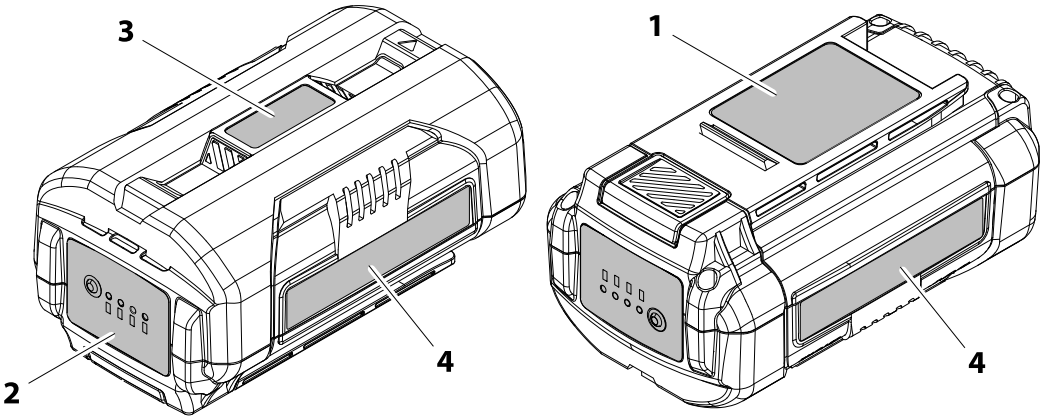

Figure 5-9. Battery Pack Decal Installation

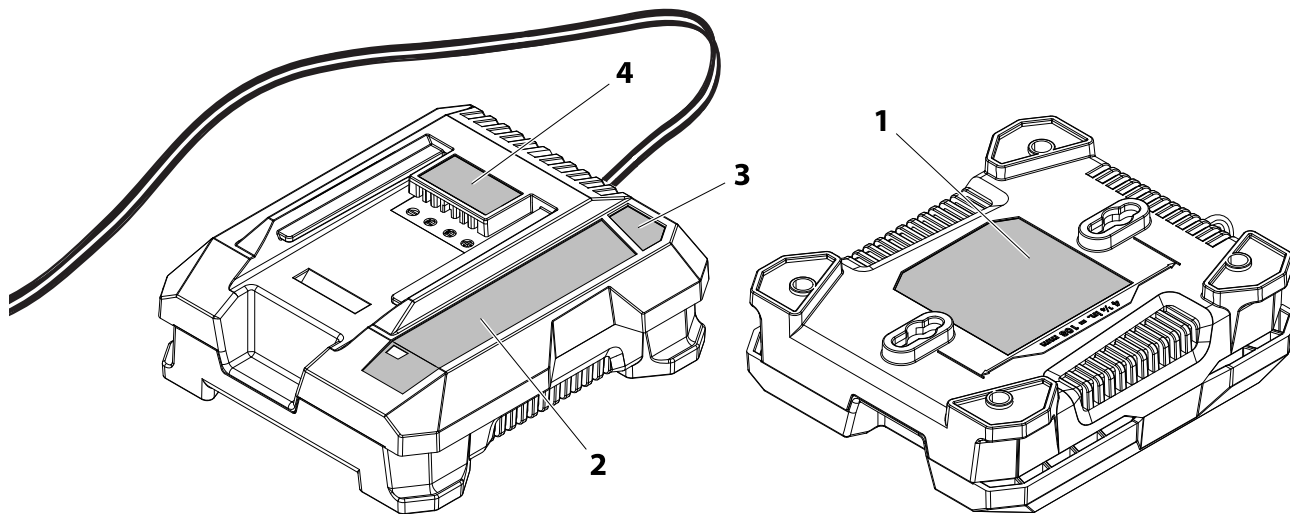

Figure 5-10. Battery Charger Decal Installation

SECTION 6. SERVICE/MAINTENANCE AND REPLACEMENT PARTS

6.1 INTRODUCTION - MAINTENANCE SAFETY PRECAUTIONS

General

This section contains the general safety precautions which must be observed during maintenance of the aerial platform. It is important that maintenance personnel pay strict attention to these warnings and precautions to avoid possible injury to themselves or others or damage to the equipment. A maintenance program must be established by a competent person and must be followed to ensure that the machine is safe to operate.

NOTICE

JLG MAY HAVE ISSUED SAFETY BULLETINS FOR YOUR JLG PRODUCT. CONTACT JLG OR THE LOCAL AUTHORIZED JLG SERVICE CENTRE FOR INFORMATION CONCERNING SAFETY RELATED BULLETINS WHICH MAY HAVE BEEN ISSUED FOR YOUR JLG PRODUCT. ALL ITEMS REQUIRED BY THE SAFETY RELATED BULLETINS MUST BE COMPLETED ON THE AFFECTED JLG PRODUCT.

Due to continuous product improvement, JLG reserves the right to make specification changes without prior notification. Contact JLG for updated information.

⚠ WARNING

MODIFICATION OF THE MACHINE WITHOUT CERTIFICATION BY A RESPONSIBLE AUTHORITY THAT THE MACHINE IS AT LEAST AS SAFE AS ORIGINALLY MANUFACTURED IS AN OSHA SAFETY VIOLATION.

Your safety, and that of others, is the first consideration when engaging in the maintenance of equipment. Always be conscious of moving parts and pinch points. Do not allow heavy objects to rest in an unstable position. When raising a portion of the equipment, ensure that adequate support is provided.

⚠ WARNING

SINCE THE MACHINE MANUFACTURER HAS NO DIRECT CONTROL OVER THE FIELD INSPECTION AND MAINTENANCE, SAFETY IN THESE AREAS IS THE RESPONSIBILITY OF THE OWNER/OPERATOR.

SECTION 6 - SERVICE/MAINTENANCE AND REPLACEMENT PARTS

Maintenance Safety

WARNING

FAILURE TO COMPLY WITH SAFETY PRECAUTIONS LISTED IN THIS SECTION COULD RESULT IN MACHINE DAMAGE, PERSONNEL INJURY OR DEATH AND IS A SAFETY VIOLATION.

- REMOVE ALL RINGS, WATCHES, AND JEWELRY WHEN PERFORMING ANY MAINTENANCE.
- DO NOT WEAR LONG HAIR UNRESTRAINED, OR LOOSE FITTING CLOTHING AND NECKTIES WHICH ARE APT TO BECOME CAUGHT ON OR ENTANGLED IN EQUIPMENT.
- OBSERVE AND OBEY ALL DANGER, WARNING, CAUTION AND OTHER INSTRUCTIONS ON MACHINE AND IN OPERATION, SAFETY, SERVICE & MAINTENANCE MANUAL.
- KEEP STANDING SURFACES AND HAND HOLDS FREE OF OIL, GREASE, WATER, ETC.
- NEVER WORK UNDER AN ELEVATED PLATFORM UNTIL PLATFORM HAS BEEN SAFELY RESTRAINED FROM ANY MOVEMENT BY BLOCKING OR OVERHEAD SLING.
- BEFORE MAKING ADJUSTMENTS OR PERFORMING ANY OTHER MAINTENANCE, SHUT OFF ALL POWER CONTROLS.
- KEEP ALL SUPPORT EQUIPMENT AND ATTACHMENTS STOWED IN THEIR PROPER PLACE.
- USE ONLY APPROVED, NONFLAMMABLE CLEANING SOLVENTS.

6.2 MACHINE PREPARATION, INSPECTION AND MAINTENANCE

General

This section provides the necessary information needed by those personnel that are responsible to place the machine in operation readiness and maintain its safe operating condition. For maximum service life and safe operation, ensure that all necessary inspection and maintenance has been completed before placing the machine into service.

Preparation, Inspection, and Maintenance

It is important to establish and conform to a comprehensive inspection and preventive maintenance program. Table 6-1. outlines the periodic machine inspection and maintenance recommended by JLG. Consult your national, regional, or local regulations for further requirements for aerial work platforms. The frequency of inspection and maintenance must be increased as environment, severity and frequency of usage requires.

Pre-Start Inspection

It is the user's or operator's primary responsibility to perform a Pre-Start Inspection of the machine prior to use daily or at each change of operator. Reference Section 2 in this manual for completion procedures for the Pre-Start Inspection.

The manual must be read in its entirety and understood prior to performing the Pre-Start Inspection.

Frequent and Pre-Delivery Inspection

The Frequent Inspection and Pre-Delivery Inspection shall be performed by a competent person or a qualified mechanic.

The Frequent Inspection and Pre-Delivery Inspection procedures are performed in the same manner, but at different times. The Pre-Delivery Inspection shall be performed prior to each sale, lease, or rental delivery. The Frequent Inspection shall be accomplished for each machine in service for 3 months; out of service for a period of more than 3 months; or when purchased used. The frequency of this inspection must be increased as environment, severity and frequency of usage requires.

Reference the appropriate areas of this manual for servicing and maintenance procedures.

Annual Machine Inspection

The Annual Machine Inspection must be performed by a competent person or a qualified mechanic on an annual basis, no later than thirteen (13) months from the date of the prior Annual Machine Inspection.

Reference the Service and Maintenance Sections of this Manual and appropriate JLG inspection form for performance of this inspection.

NOTICE

IT IS IMPORTANT THAT JLG HAS UPDATED OWNERSHIP INFORMATION FOR EACH MACHINE COMPONENT. WHEN PERFORMING EACH ANNUAL MACHINE INSPECTION, NOTIFY JLG OF THE CURRENT MACHINE COMPONENT OWNERSHIP.

Preventive Maintenance

In conjunction with the specified inspections, maintenance shall be performed by a competent person such as a qualified JLG equipment mechanic.

6.3 PREVENTIVE MAINTENANCE AND INSPECTION SCHEDULE

The preventive maintenance and inspection checks are listed and defined in the following table. This table is divided into two basic parts, the "AREA" to be inspected and the "INTERVAL" at which the inspection is to take place. Under the "AREA" portion of the table, the various systems along with the components that make up that system are listed. The "INTERVAL" portion of the table is divided into four columns representing the various inspection time periods. The numbers listed within the interval column represent the applicable inspection code for which that component is to be checked.

The checks and services listed in this schedule are not intended to replace any local or regional regulations that may pertain to this type of equipment nor should the lists be considered as all inclusive. Variances in interval times may occur due to climate and/or conditions and depending on the location and use of the machine.

SECTION 6 - SERVICE/MAINTENANCE AND REPLACEMENT PARTS

Table 6-1. Preventative Maintenance & Inspection Schedule

AREA ON MACHINE	INTERVAL		
	Pre-Start Inspection	Pre-Delivery or Frequent Inspection	Annual (Yearly) Inspection
	Prior to use each day; or at each operator change	Prior to each sale, lease or delivery; in service for 3 months or more; or purchased used	No later than 13 months from the date of the prior inspection
Mast	1,5	1,2,5	1,2,3,5
Mast Drive Screw Lubrication			14,16
Mast Mount (Stump-Counterweight) ^(a)	3,5	3,4,5	3,4,5
Manual Descent Crank	1	1,12	1,3,12
Platform	1,5	1,5	1,3,4,5,7
Platform Latch	1,7	1,3,6,7	1,3,6,7
Platform Gates	1,7	1,3,5,7	1,3,5,7
Platform Lanyard Anchor Point		3,4	3,4
Base Frame	3,4,5	3,4,5	3,4,5
Adjustable Feet/Castor Wheels	1	1,3,7	1,3,7
Bubble Level	1,7	1,7	1,7
Wheels	1,3,7	1,3,7	1,3,7

SECTION 6 - SERVICE/MAINTENANCE AND REPLACEMENT PARTS

Table 6-1. Preventative Maintenance & Inspection Schedule

Powerpack (option)	1,3	1,3,7	1,3,7
Powerpack - Switches & Controls (option)	1	1,3,7	1,3,7
General	Pre-Start Inspection	Pre-Delivery or Frequent Inspection	Annual (Yearly) Inspection
Operator, Safety, Service & Maintenance Manual in Storage Pouch	13	13	13
All Decals/Placards Installed, Secure & Legible	13	13	13
Machine Inspection Due		14	14
No Unauthorized Modifications or Additions		13	13
All Relevant Safety Publications Incorporated		13	13
General Structural Condition and Welds	13	3,4	3,4
All Fasteners, Pins, Shields and Covers	13		1,3
Function Test of all Systems	14	14	14
Paint and Appearance		2,5	2,5
Record Inspection Date in Log Book			14
Notify JLG of Machine Ownership		14 (delivery)	14
NOTE: (a) - Lubricate mating surfaces of the mast mount once a month with a PTFE dry lubricant spray or equivalent.			

Table 6-1. Preventative Maintenance & Inspection Schedule

<p>Inspection and Maintenance Codes:</p> <ol style="list-style-type: none">1. Check for proper and secure installation2. No gouges, excessive wear, or dents showing3. Visually inspect for excessive wear, damage, cracks, or distortion4. Check for cracked or broken welds5. Check area is clean and free of debris6. Check for proper adjustment7. Check proper operation8. Check returns to neutral or "off" position when released	<ol style="list-style-type: none">9. Check for signs of leakage10. Check for wear and/or proper routing11. Check for proper tolerances12. Check proper and authorized components installed13. Verify14. Perform15. Replace16. Lubricate per instructions in Section 6.6 on page 6-18
--	---

6.4 SERVICING AND MAINTENANCE GUIDELINES

General

The following information is provided to assist you in the use and application of service and maintenance procedures contained in this chapter.



WHEN AN ABNORMAL CONDITION IS NOTED AND PROCEDURES CONTAINED HEREIN DO NOT SPECIFICALLY RELATE TO THE NOTED IRREGULARITY, WORK SHOULD BE STOPPED AND TECHNICALLY QUALIFIED GUIDANCE OBTAINED BEFORE WORK IS RESUMED.

Safety and Workmanship

Your safety, and that of others, is the first consideration when engaging in the maintenance of equipment. Always be conscious of moving components and pinch points. Do not allow heavy objects to rest in an unstable position. When raising a portion of the equipment, ensure that adequate support is provided.

Cleanliness

The most important single item in preserving the long service life of a machine is to keep dirt and foreign materials out of the vital components. Precautions have been taken to safeguard

against this. However, these items must be maintained on a scheduled basis in order to function properly.

Component Disassembly and Reassembly

When disassembling or reassembling a component, complete the procedural steps in sequence. Do not partially disassemble or assemble one part, then start on another. Always recheck your work to assure that nothing has been overlooked. Do not make any adjustments, other than those recommended, without obtaining proper approval.

6.5 FT70 and FT140 Mast Service Procedure

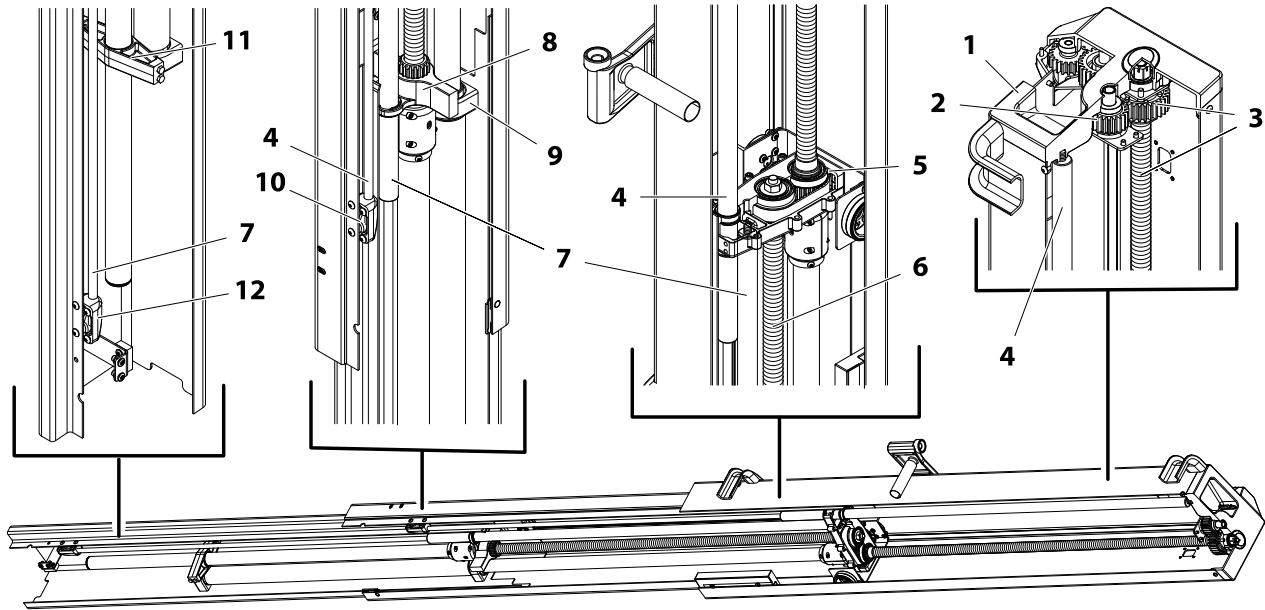

Figure 6-1. FT70 and FT140 - Mast Component Overview

- | | | |
|--|---|---|
| 1. Mast Top Cap | 5. Gear Box Assembly (w/top cover cutaway) | 9. Outer-Mast Drive-Screw - Cover Guide |
| 2. Main Drive Gear (Hex Shaft) | 6. Mid -Mast Section - Drive-Screw | 10. Outer to Mid-Mast Section - Gas Strut Lower Mount |
| 3. Outer-Mast Section Drive-Screw and Clutch | 7. Mid - Mast Section - Gas Strut Cylinder | 11. Mid-Mast Drive-Screw - Lower Mount |
| 4. Outer-Mast Section - Gas Strut Cylinder | 8. Mid to Inner-Mast Section - Drive Screw Attach Bracket | 12. Mid to Inner-Mast Section - Gas Strut Lower Mount |

SECTION 6 - SERVICE/MAINTENANCE AND REPLACEMENT PARTS

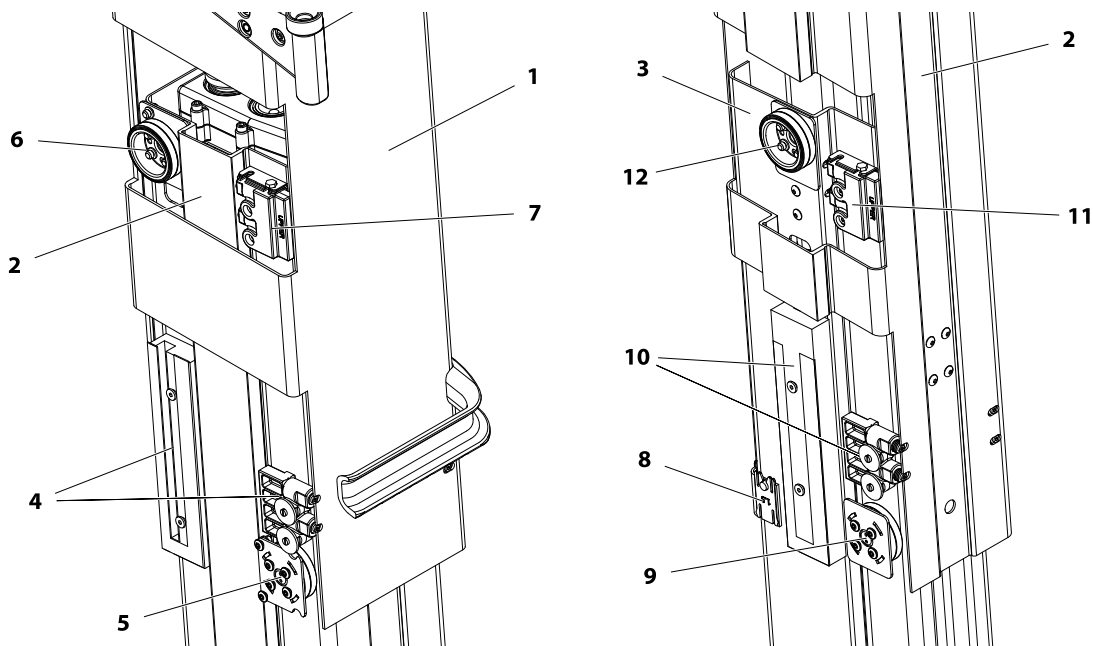

Figure 6-2. FT70 and FT140 - Mast Slide-Pad Positioning

- | | | |
|--|--|---|
| 1. Outer-Mast Section (<i>side cut-away</i>) | 5. Outer-Mast Section Lower Main Bearing (<i>1 per side</i>) | 9. Mid-Mast Section Lower Main Bearing (<i>1 per side</i>) |
| 2. Mid-Mast Section (<i>side cut-away</i>) | 6. Mid-Mast Section Upper Main Bearing (<i>1 per side</i>) | 10. Mid-Mast Section Lower Slide Pads (<i>1 per side</i>) |
| 3. Inner-Mast Section | 7. Mid-Mast Section Upper Slide Pad (<i>1 per side</i>) | 11. Inner-Mast Section Upper Slide Pad (<i>1 per side</i>) |
| 4. Outer-Mast Section Lower Slide Pads (<i>2 per side</i>) | 8. Mid-Mast Section Shim Pad (<i>1 per side</i>) | 12. Inner-Mast Section Upper Main Bearing (<i>1 per side</i>) |

⚠ WARNING

DUE TO GAS STRUT CYLINDER PRESSURE WITHIN THE MAST ASSEMBLY, FULLY EXTEND THE MAST ON A SUITABLE WORK SURFACE THEREBY RELIEVING MOST OF THE STRUT CYLINDER COMPRESSION BEFORE MAST DISASSEMBLY. FAILURE TO DO SO COULD RESULT IN INJURY OR DEATH.

Relieving Gas Strut Cylinder Pressure

The FT70 and FT140 mast assemblies are mechanically the same inside. To help extend the mast assembly sections during operation, there are two gas strut cylinders mounted internally. When the mast is fully retracted the gas struts are compressed. The following procedures must ALWAYS be performed before disassembling the mast assembly.

1. Lay mast on a clean sturdy workbench large enough to fully support the mast assembly.
2. FULLY extend the mast using the hex drive shaft in the main drive gear at the top of the mast assembly.
3. With the mast FULLY extended most of the pressure from both the mid and outer-mast gas strut cylinders is relieved. However, both gas struts still have an inch or two of compression before being fully released. Perform the following steps to relieve the outer and mid-mast section gas strut cylinder pressure using the gas strut mount removal tool (JLG P/N-1001181912).

- a. Slide special tool into the bottom of the mid-mast section to engage the outer to mid-mast section gas strut cylinder rod mount - *Item 10, Figure 6-1. on page 6-9*

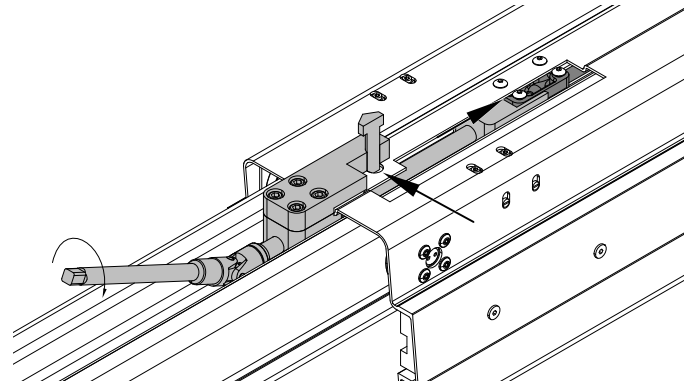

- b. Align the large screw on the end of the tool with the large hole (*arrow*) in the lower end of the mid-mast section. Thread the large screw in to engage the hole. This will hold the tool in place on the mast when relieving the pressure from the outer-mast gas strut cylinder rod mount.

SECTION 6 - SERVICE/MAINTENANCE AND REPLACEMENT PARTS

- c. Thread the long screw in until the metal block on the end of it contacts the gas strut mount to hold the remaining pressure of the gas strut. Do not overtighten.

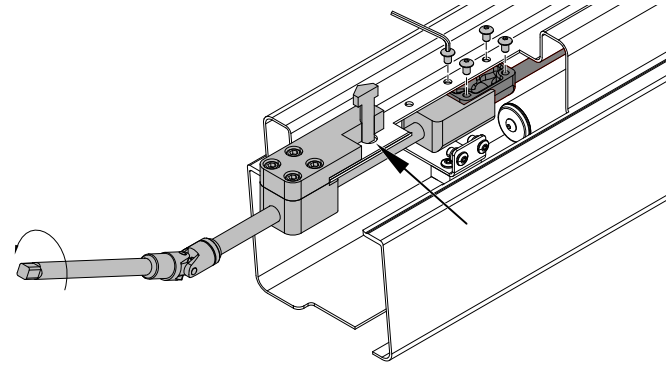
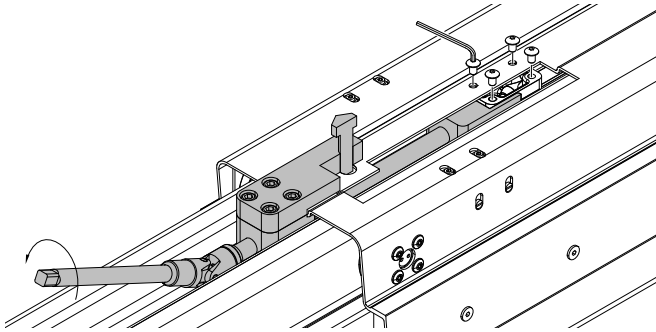

- d. Remove the four (4) hex drive screws holding the strut mount to the mid-mast section.
 - e. Once all four screws are removed, slowly unscrew the tool block releasing the remaining pressure from the gas strut, approximately one (1) to two (2) inches.
 - f. Once pressure is relieved, remove the tool from the mast and allow strut to lay loose in the mast.
4. Next release the pressure from the mid to inner-mast section gas strut - *Item 12, Figure 6-1. on page 6-9, same as the outer to mid-mast procedure.*
- a. Slide special tool into the bottom of the inner-mast section to engage the mid to inner-mast section lower gas strut cylinder mount.
 - b. Align the large screw on the end of the tool with the large hole in the lower end of the mid-mast section. Thread the large screw in to engage the hole. This will hold the tool in place on the mast when relieving the pressure from the mid-mast gas strut cylinder rod mount.
 - c. Remove the four (4) hex drive screws holding the strut mount to the mid-mast.
 - d. Once all four screws are removed, slowly unscrew the tool block releasing the remaining pressure

- from the gas strut, approximately one (1) to two (2) inches.
- e. Once pressure is relieved remove the tool from the mast and allow strut to lay loose in the mast.

Removing Mast Top Cap

⚠ WARNING

DUE TO GAS STRUT CYLINDER PRESSURE - DO NOT REMOVE THE MAST TOP CAP UNTIL THE PROCEDURE FOR "RELIEVING GAS STRUT CYLINDER PRESSURE" ON PAGE 6-11." IS PERFORMED FIRST. FAILURE TO DO SO COULD RESULT IN INJURY OR DEATH.

With the gas strut cylinder pressure relieved, remove the top cap from the top of the mast.



1. Remove the protective cap from the outer-mast section drive screw castle nut, on top of the mast, and remove the cotter key from the nut.

2. Remove the castle nut from the end of the drive screw.

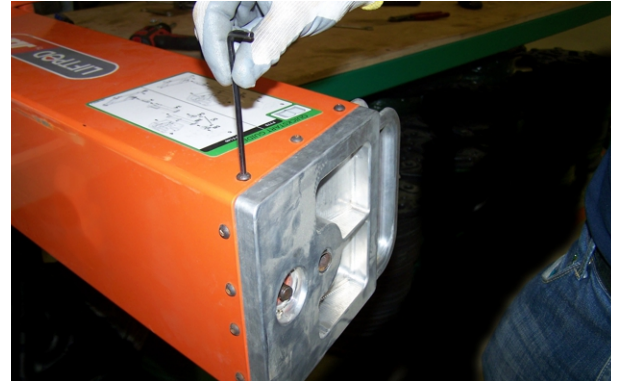

⚠ WARNING

DUE TO GAS STRUT CYLINDER PRESSURE - DO NOT REMOVE THE MAST TOP CAP UNTIL THE "RELIEVING GAS STRUT CYLINDER PRESSURE" ON PAGE 6-11." PROCEDURE IS PERFORMED FIRST. FAILURE TO DO SO COULD RESULT IN INJURY OR DEATH.

3. Remove the screws around the top perimeter of the outer-mast section holding the top cap to the outer-mast section.
4. Remove the screws holding the upper mast handle to the top of the mast.



5. Before removing the top cap the slide pads and shims must be removed from one side of the mid-inner and mid-outer mast extrusions, this will make it easier to slide the drive assembly out of the mast.
6. Once all the top cap screws are removed, slide the complete top cap assembly out the top of the outer-mast section.
7. At the top of the outer-mast drive screw is a clutch gear assembly. When sliding the top cap out of the outer-mast section the drive screw and the top cap may come apart leaving the clutch gear assembly on the top of the drive screw. Remove and lay aside, or replace if damaged.

Outer-Mast Section Gas Strut Removal

8. The outer-mast section gas strut is attached to the mast cap with a threaded stud on the barrel end of the cylinder. To remove the gas strut cylinder, just unscrew it from the top cap, then slide it out of the bottom of the mast.
Inspect the gas strut guide where the gas strut passes through the gear box for damage, replace if necessary.

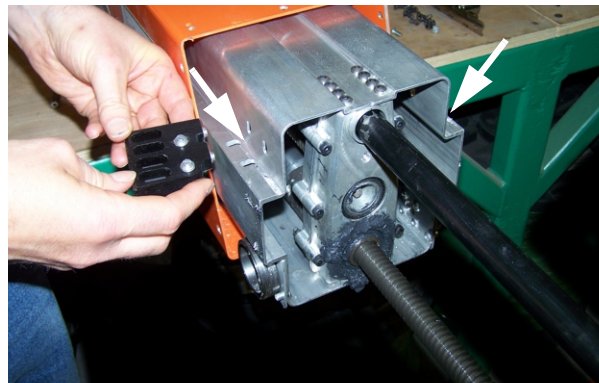

9. At this point the outer-mast section, can be slid down exposing the mid-mast section with the gearbox attached, or it can be completely removed from the mast assembly, slide it down over the mid and inner mast sections. When doing so the outer and mid sec-

tion slide pads may also fall out during removal. Take notice to the position and orientation of each slide pad when sliding apart. *Figure 6-2, on page 6-10* also shows the mast section slide pad configuration for re-assembly.

10. If further tear-down is required proceed to gearbox removal.

GearBox Removal

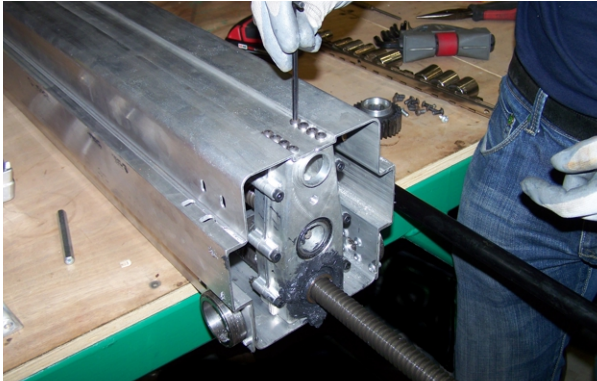

11. Remove the (16) screws, two rows of (4) each side, securing the gearbox to the mid-mast section.

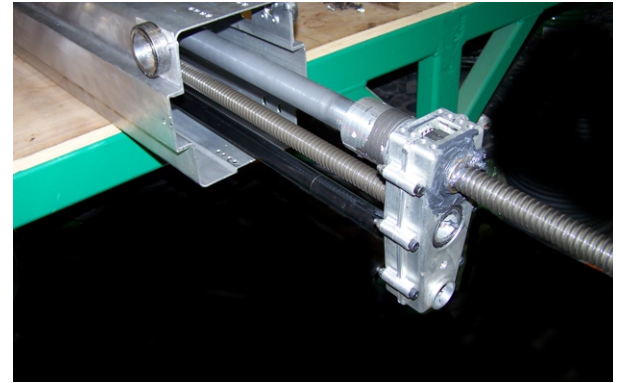

12. Once the gearbox screws are removed, slide the gearbox, drive screws and remaining gas strut assembly from the mid and inner-mast sections.

Mid-Mast Section Gas Strut Removal

13. The gas strut cylinder uses a threaded stud to attach the barrel end to the gearbox. To remove the gas strut attached to the bottom of the gearbox, just unscrew it from the bottom of the gearbox and slide it out of the bottom of the mast.
Inspect the gas strut guide where the gas strut passes through the drive screw attach bracket for damage, replace if necessary.

Gearbox Housing Disassembly

If the drive belt or bearings need replaced use the following steps to take the gearbox apart.

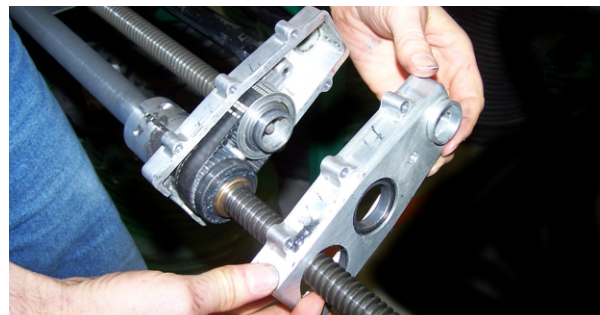
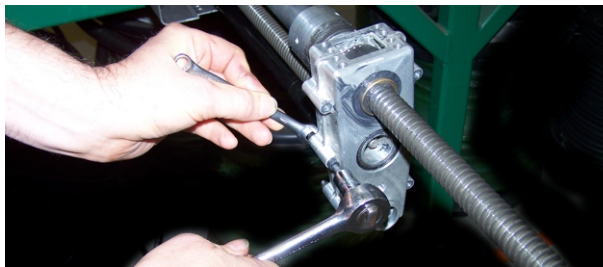

2. Using a hammer and soft punch, tap the parting edges of the top half of the gearbox, tap evenly around the perimeter of the housing. Once the halves are separated use a wide blade screw driver or similar tool and evenly pry the halves further apart, until the housing is released from the bearings. The housing can now be slid completely off the end of the drive screw if necessary.
3. If the drive belt is broken or damaged, remove all debris from the gearbox housing before placing a new belt onto the drive gears.
4. If the new belt cannot be slid down over the two drive gears, remove the nut from the driven drive gear and remove the gear from the drive screw.

1. Remove the (6) screws and nuts from the sides of the gearbox housing.

5. Reassemble the new drive belt over both drive gears and slide back into position.
6. Thread the nut back on the driven gear screw and tighten to secure the driven gear to the top of the drive screw.
7. Carefully reassemble the upper half of the gearbox housing back onto the lower half of the gearbox housing. Assemble evenly at both ends to avoid cracking or breaking the housing.
8. Use the (6) screws and nuts to secure the upper housing to the lower housing.

Reassemble the mast assembly reversing the above procedures.

Reassemble the mast with the drive screws extended.

Use *Figure 6-2. on page 6-10* for slide pad positioning when reassembling the mast sections. Set slide pad adjustment screws tight enough to remove any mast section movement side to side and fore and aft. Do not overtighten slide pad adjustment screws, this will bind the mast thereby reducing the number of up/down cycles when using the optional power-pack or portable drill.

Check the nylon gas strut guides, where the gas struts pass through the gear box (item 5 - Figure 6-1. on page 6-9) and the drive screw attach bracket (item 8 - Figure 6-1. on page 6-9) for excessive wear or breakage. Replace if necessary.

Use the gas strut removal tool to compress and reattach the gas strut mounts and align the mount holes with the mast holes. Secure mounts with the allen head socket screws.

6.6 Mast Drive Screw Lubrication

To keep the mast assembly operating smoothly and efficiently, the outer and mid-mast drive screws must be lubricated annually.

There are three (3) access covers on the upper portion of the outer mast section, one on each side, and one on the back of the mast.

Only two (2) covers must be removed to lubricate the mast drive screws, the cover on the rear, and the cover on the auxiliary drive port (right) side of the mast. (See Figure 6-3.)

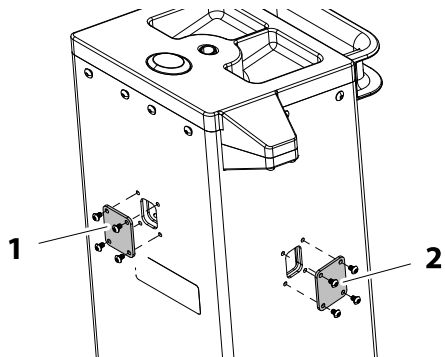

Figure 6-3. Lubrication Access Covers

1. Rear Access Cover 2. Right Side Access Cover

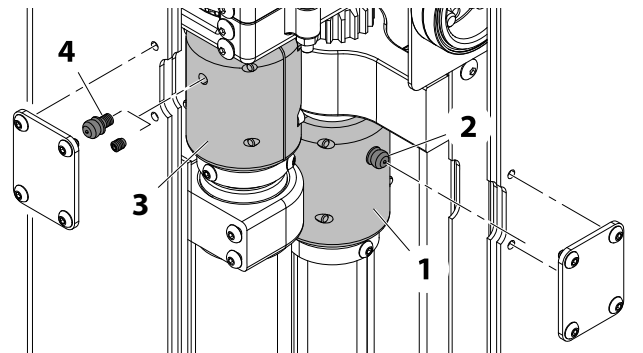

Figure 6-4. Mast Lubrication Points

(mast sections shown cutaway for illustrative purposes only)

- | | |
|--|---|
| 1. Mid Mast Drive Screw Safety Nut Housing (Fixed) | 3. Outer Mast Drive Screw Safety Nut Housing (Rotating) |
| 2. Grease Nipple (Fixed) | 4. Grease Nipple (Remove) Screw Plug (Permanent) |

NOTE: The mast must be completely retracted (stowed) for the access holes of the three mast sections to align properly.

Mid-Mast Drive Screw Lubrication

1. Remove right side access cover.
2. Place grease gun on the grease nipple and fill the safety nut housing cavity with the appropriate grease. (See Figure 6-5.)
3. Re-install right side access cover.

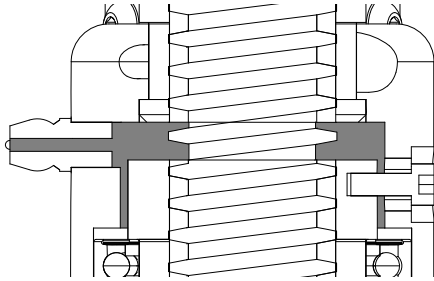

Figure 6-5. Safety Nut Housing Grease Cavity

Outer-Mast Drive Screw Lubrication

NOTE: The grease nipple for the outer mast drive screw must be installed to lubricate and then removed once lubrication is complete. A grease nipple (M6 x 1 thread) is supplied from the factory in a plastic bag inside the manual storage box.

Unlike the fixed safety nut housing of the mid mast drive

screw, the outer mast drive screw safety nut housing rotates during operation. There is not enough clearance within the mast to leave this grease nipple on the housing.

1. Remove the rear access cover. (See Figure 6-3.)
2. If necessary turn drive shaft to align the lubrication hole with the access hole.
3. Remove the screw plug from the safety nut housing.
4. Thread the grease nipple into the hole and tighten.
5. Place grease gun on the grease nipple and fill the safety nut housing cavity with the appropriate grease.
6. Remove the grease nipple from the lubrication hole.
7. Re-install the screw plug back into the lubrication hole. DO NOT thread the screw plug in until bottomed, only until it is just clear of the outer surface of the safety nut housing.
8. Re-install the rear access cover back onto the mast.

NOTICE

FAILURE TO REMOVE THE GREASE NIPPLE AND REPLACE WITH THE SCREW PLUG COULD CAUSE DAMAGE OR MALFUNCTION OF THE MAST ASSEMBLY.

6.7 REPLACEMENT PART/KITS OVERVIEW

The following details the various replacement kits that can be ordered from your Authorized JLG Service Center.

BASE - FT140

(See Figure 6-6. on page 6-24)

1. **Castor Adjuster - Handle** - (JLG Part No. 1001191496)
2. **Caster Adjuster Kit** - (JLG Part No. 1001190686)
3. **Caster Wheel/Brake Mechanism** - (JLG Part No. 1001190688)
4. **Manual Descent Tool - Installation Kit** - (JLG Part No. 1001191497)
5. **Rear Wheel Replacement Kit** - (JLG Part No. 1001191498)
6. **Bubble Level** - (JLG Part No. 2420140)
7. **Mast (Stump) Socket - FT140 ONLY** (JLG Part No. 1001150693)
8. **Slip-Proof Tape, 3M - 1 in. Width (each)** - (JLG Part No. 1001188693)
9. **FT140 Base Assembly - Complete with:**
 - English Decals** (JLG Part No. 1001190672)
 - Spanish Decals** (JLG Part No. 1001211102)

Portuguese Decals (JLG Part No. 1001211110)

French Decals (JLG Part No. 1001211120)

10. FT140 Base Assembly - Decal Kit Only:

English (JLG Part No. 1001165758)

Spanish (JLG Part No. 1001211083)

Portuguese (JLG Part No. 1001211089)

French (JLG Part No. 1001211095)

BASE - FT70

(See Figure 6-7. on page 6-25)

1. **Foot Adjuster** - (JLG Part No. 1001150112)
2. **Foot Adjuster - Top Cap Kit** (JLG Part No. 1001181648)
3. **Caster Mechanism - Handle Kit** - (JLG Part No. 1001181654)
4. **Caster Mechanism Kit - Complete** - (JLG Part No. 1001181660)
5. **Rear Wheel Replacement Kit** - (JLG Part No. 1001192762)
6. **Manual Descent Tool - Installation Kit** - (JLG Part No. 1001191497)
7. **Bubble Level** - (JLG Part No. 2420140)
8. **Mast (Stump) Socket - FT70 ONLY** (JLG Part No. 1001150134)

- 9. **Slip-Proof Tape, 3M - 1 in. Width (each)** - (JLG Part No. 1001188693)
- 10. **FT70 Base Assembly - Complete with:**
 - English Decals** (JLG Part No. 1001150102)
 - Spanish Decals** (JLG Part No. 1001211099)
 - Portuguese Decals** (JLG Part No. 1001211107)
 - French Decals** (JLG Part No. 1001211116)
- 11. **FT70 Base Assembly - Decal Kit Only:**
 - English** (JLG Part No. 1001152379)
 - Spanish** (JLG Part No. 1001211081)
 - Portuguese** (JLG Part No. 1001211087)
 - French** (JLG Part No. 1001211093)

- 5. **Mast Main Bearing Kit** - (JLG Part No. 1001181698)
- 6. **Slide Pad/Wear Pad Kit** (JLG Part No. 1001192996)
- 7. **GearBox** (JLG Part No. 1001214505)
- 8. **GearBox-Drive Belt** (JLG Part No. 1001148707)
- 9. **Thread Tube Support Kit** (JLG Part No. 1001181700)
- 10. **Mast Handles Kit** - FT70 - (JLG Part No. 1001211369)
- 11. **Mast Handles Kit** - FT140 - (JLG Part No. 1001211370)
- 12. **FT70 Mast Assembly Complete with:**
 - English Decals** (JLG Part No. 1001148682)
 - Spanish Decals** (JLG Part No. 1001211101)
 - Portuguese Decals** (JLG Part No. 1001211109)
 - French Decals** (JLG Part No. 1001211119)
- 13. **FT140 Mast Assembly Complete with:**
 - English Decals** (JLG Part No. 1001149868)
 - Spanish Decals** (JLG Part No. 1001211104)
 - Portuguese Decals** (JLG Part No. 1001211111)
 - French Decals** (JLG Part No. 1001211122)

MAST - FT70 and FT140

(See Figure 6-1. on page 6-9 and Figure 6-2. on page 6-10)

- 1. **Gas Strut Mount Removal - Tool Kit** - (JLG Part No. 1001181912)
- 2. **Mast Top Cap** (JLG Part No. 1001211299) requires drilling holes for mounting screws, M5 x 0.8 thread tap included in kit
- 3. **Clutch Gear Assembly** (JLG Part No. 1001183857)
- 4. **Gas Strut Cylinder Replacement Kit (includes both struts)** - (JLG Part No. 1001181697)

Note: FT140 Mast Assembly Complete does not include the FT70 Mast Assembly.

- 14. **FT70 Mast Assembly - Decal Kit Only:**
 - English** (JLG Part No. 1001152422)
 - Spanish** (JLG Part No. 1001211082)

SECTION 6 - SERVICE/MAINTENANCE AND REPLACEMENT PARTS

Portuguese (JLG Part No. 1001211088)

French (JLG Part No. 1001211094)

15. FT140 Mast Assembly - Decal Kit Only:

English (JLG Part No. 1001164959)

Spanish (JLG Part No. 1001211084)

Portuguese (JLG Part No. 1001211090)

French (JLG Part No. 1001211096)

PLATFORM - FT70 and FT140

(See Figure 6-8. on page 6-26)

1. Platform to Mast Latch Kit -

(JLG Part No. 1001181996)

2. Platform to Mast Guide Pin Kit (JLG Part No.

1001181998)

3. Portable Drill to Platform Rail Strap -

(JLG Part No. 1001149844)

4. Manual Descent Crank Kit -

(JLG Part No. 1001181999)

5. Manual Pouch and Accessory Kit:

Includes Manual Pouch, Hex Drive Bit, Manual Pouch Decal, Pouch Mounting Rivets, Mast Grease Fitting, and Manual:

English (JLG Part No. 1001192779)

Spanish (JLG Part No. 1001211648)

Portuguese (JLG Part No. 1001211949)

French (JLG Part No. 1001211650)

6. Platform Gate Kit (JLG Part No. 1001182002)

7. Platform Assembly Complete with:

English Decals (JLG Part No. 1001159813)

Spanish Decals (JLG Part No. 1001211098)

Portuguese Decals (JLG Part No. 1001211106)

French Decals Installed (JLG Part No. 1001211115)

8. Platform Assembly - Decal Kit Only:

English (JLG Part No. 1001152154)

Spanish (JLG Part No. 1001211080)

Portuguese (JLG Part No. 1001211086)

French (JLG Part No. 1001211092)

ACCESSORIES - FT70 and FT140

(See Figure 6-9. on page 6-27)

1. Tool Tray - Attach Straps - (JLG Part No. 1001183985)

2. Hex Drive Bit For Drive Gear Socket -

(JLG Part No. 1001150300)

3. Power Pack - Control Unit - (JLG Part No.

1001172228)

4. Power Pack - Drive Unit (FT140 Only) - (JLG Part No.

1001172229)

SECTION 6 - SERVICE/MAINTENANCE AND REPLACEMENT PARTS

5. **Drive Unit - Power Cord - (FT140 Only) -**
(JLG Part No. 1001172814)
6. **Battery Pack Assembly - 40V 2.6 Ah Lithium Ion -**
(JLG Part No. 1001172230)
7. **Battery Pack Assembly - 40V 4.0 Ah Lithium Ion -**
(JLG Part No. 1001212695)
8. **Battery Charger Assembly - 40V Lithium Ion-**
(JLG Part No. 1001175464) - Will charge both the 2.6 Ah and 4.0 Ah Lithium Ion Batteries
9. **Complete Power Pack Kit - (FT70 Only) -**
(JLG Part No. 1001172132) - Not Shown - includes Control Unit, Battery Pack, Battery Charger and Tote Bag
10. **Complete Power Pack Kit - (FT140 Only) -**
(JLG Part No. 1001172133) - Not Shown - includes Control Unit, Drive Unit, Battery Pack, Battery Charger and Tote Bag
11. **Accessory Tote Bag - Black with JLG Logo -** (JLG Part No. 1001183859)
12. **Power Pack - Control Unit - Decal Kit Only -**
(JLG Part No. 1001171988)
13. **Power Pack - FT140 Power Unit - Decal Kit Only -**
(JLG Part No. 1001173194)
14. **Power Pack - Battery Charger - Decal Kit Only -**
(JLG Part No. 1001171990)
15. **Power Pack - Battery Pack - Decal Kit Only -**
(JLG Part No. 1001171989)
16. **Canada C.S.A - Decal and Warning Bell Kit:**
English (JLG Part No. - 1001211128)
French (JLG Part No. - 1001211317)
17. **Tool Tray with:**
English Decals (JLG Part No. 1001180960)
Spanish Decals (JLG Part No. 1001211105)
Portuguese Decals (JLG Part No. 1001211113)
French Decals (JLG Part No. 1001211123)
18. **Tool Tray - Decal Kit Only:**
English (JLG Part No. 1001192760)
Spanish (JLG Part No. 1001211085)
Portuguese (JLG Part No. 1001211091)
French (JLG Part No. 1001211097)

6.8 FT140 Base Frame Components - Service Kit - Locations

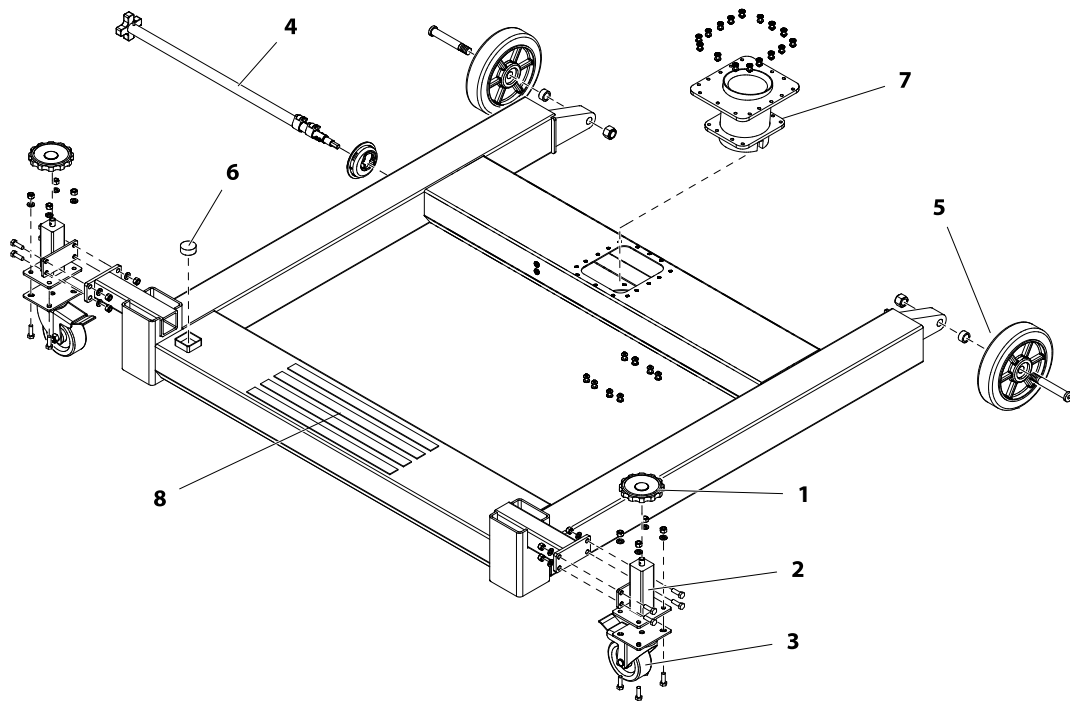

1. Castor Wheel Adjuster - Handle
2. Castor Wheel Adjuster Kit
3. Caster Wheel/Brake Kit
4. Manual Descent Tool Kit
5. Rear Wheel Replacement Kit
6. Bubble Level Kit
7. Mast Stump Mount Kit
8. Slip-Proof Tape Strips

Figure 6-6. FT140 - Base Frame Components -Service Kit - Locations

6.9 FT70 Base Frame Components - Service Kit - Locations

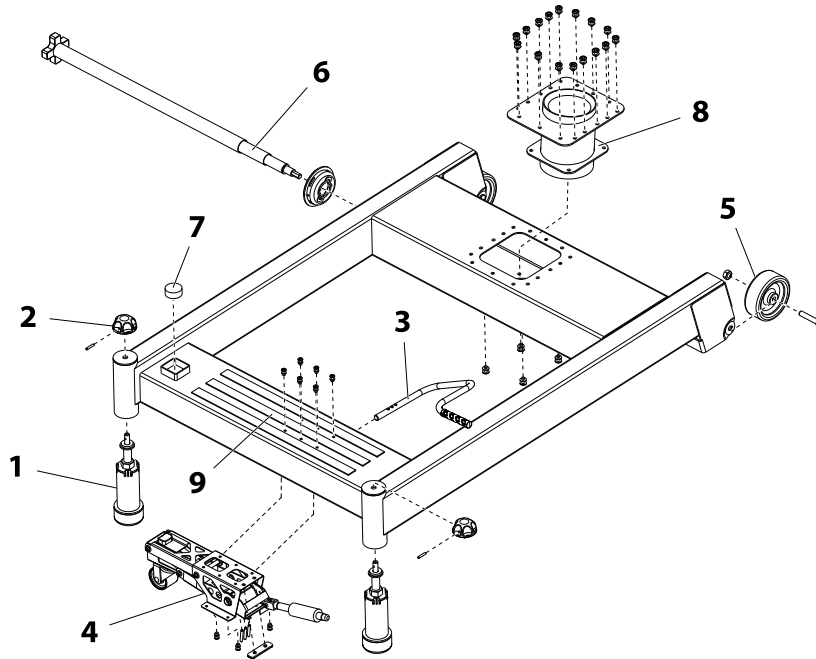

1. Foot Adjuster Kit
2. Foot Adjuster - Top Cap Kit
3. Caster Mechanism - Handle Kit
4. Caster Mechanism - Complete
5. Rear Wheel Replacement Kit
6. Manual Descent Tool Kit
7. Bubble Level Kit
8. Mast Stump Mount Kit
9. Slip-Proof Tape Strips

Figure 6-7. FT70 - Base Components - Service Kit - Locations

6.10 Platform Component Service Kit Locations

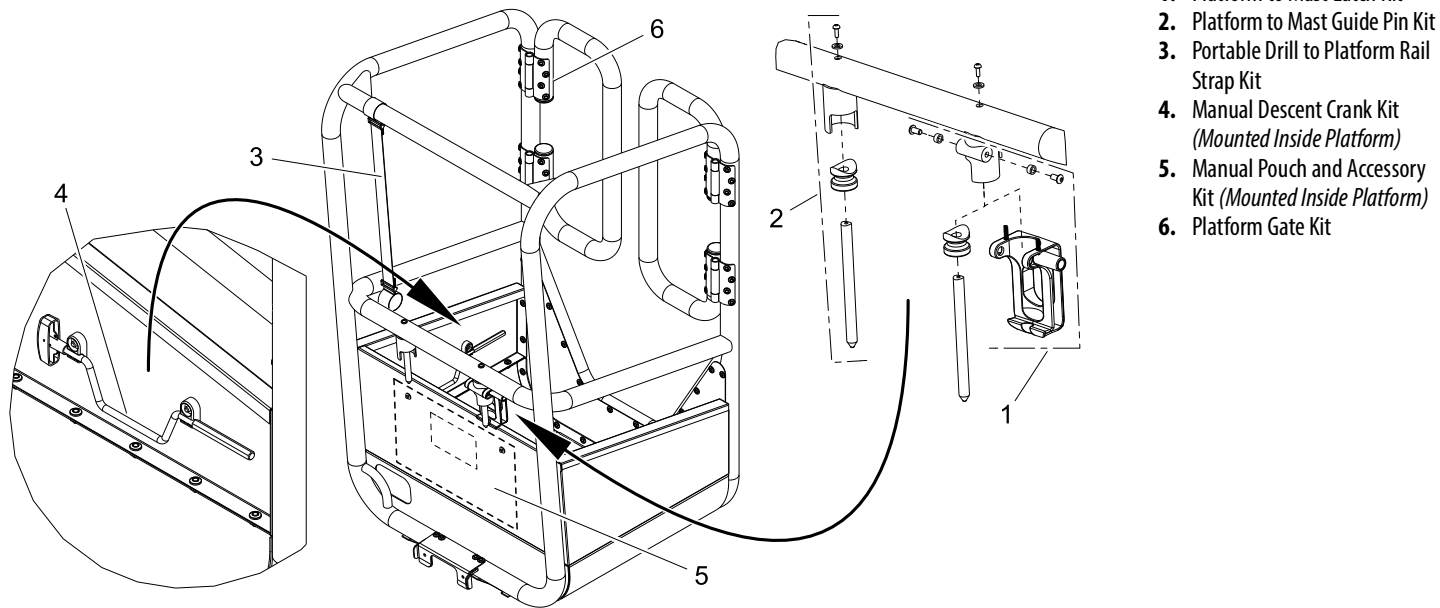

Figure 6-8. Platform Component - Service Kit - Locations

6.11 Accessory Components - Service Kits

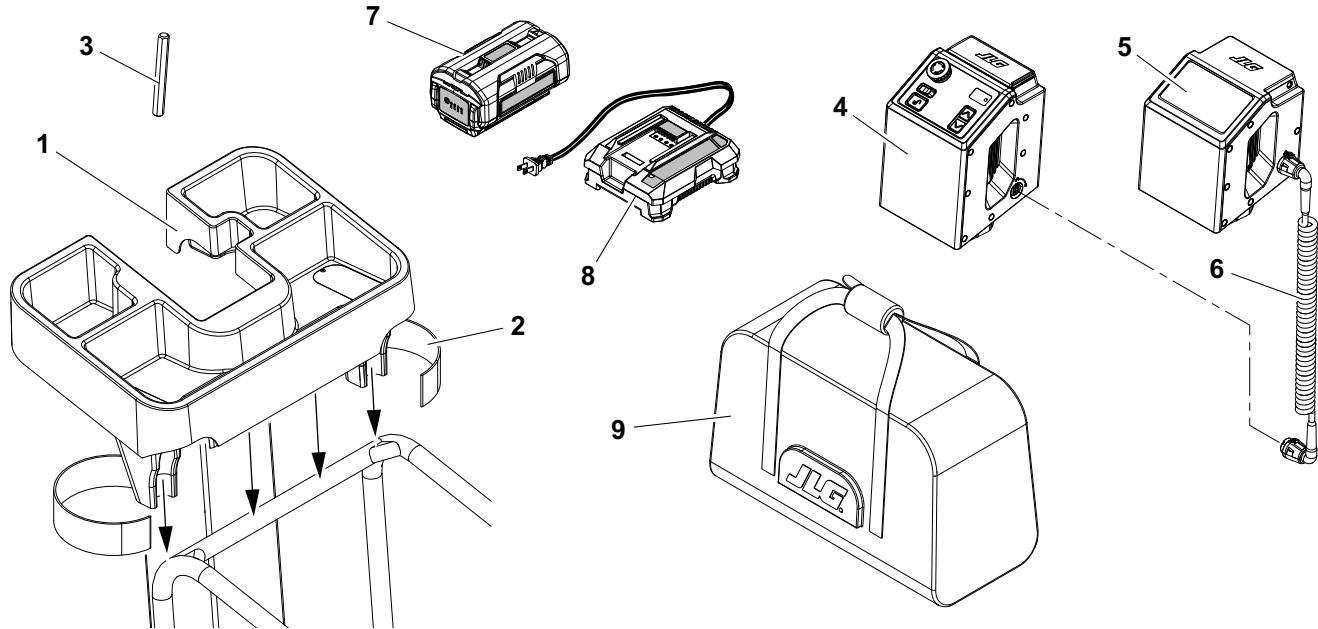

Figure 6-9. Accessory Components - Service Kit - Overview

- | | | |
|----------------------------|---|---|
| 1. Accessory Tool Tray Kit | 4. Power Pack - Control Unit Assembly | 7. 40V 2.6Ah or 4.0 Ah Lithium Ion Battery |
| 2. Tool Tray Attach Straps | 5. FT140 Power Pack - Drive Unit Assembly | 8. 40V Lithium Ion Battery Charger |
| 3. Drill Hex Drive Bit | 6. FT140 Drive Unit Power Cord | 9. Accessory Tote Bag (Black with JLG Logo) |

SECTION 7. TROUBLESHOOTING

7.1 GENERAL

This section contains troubleshooting information to be used for locating and correcting most of the operating problems which may develop in the aerial platform. If a problem should develop which is not presented in this section or which is not corrected by listed corrective actions, technically qualified guidance should be obtained before proceeding with any maintenance.

Troubleshooting Information

The troubleshooting procedures applicable to the product are listed and defined in Table 7-1., Troubleshooting.

Each malfunction within an individual group or system is followed by a listing of probable causes which will enable determination of the applicable remedial action. The probable causes and the remedial action should, where possible, be checked in the order listed in the tables.

It should be noted that there is no substitute for a thorough knowledge of the equipment and related systems.

It should be recognized that the majority of the problems arising in the machine will be centered in the power system. For this reason, every effort has been made to ensure that all likely problems in these areas are given the fullest possible treatment. In the remaining machine groups, only those problems which are symptomatic of greater problems which have more than one probable cause and remedy are included. This means that problems for which the probable cause and remedy may be immediately obvious are not listed in this section.

SECTION 7 - TROUBLESHOOTING

Table 7-1. Troubleshooting

TROUBLE	PROBABLE CAUSE	REMEDY
Machine does not assemble properly		
	Improper alignment on assembly	Check each component and assembly alignment is correct.
	Platform not fully engaged	Check alignment and slide parts on until platform latch is properly engaged.
Powerpack (optional) motor does not start		
	Emergency stop button is engaged (PUSHED IN) on powerpack	Disengage emergency stop button until it pops up (TURN CLOCKWISE).
	Direction selector or enable button not activated	Press and hold the enable button, then press and hold the 'UP' button continuously for operation, release when desired height is reached.
	Battery not installed or no charge	Properly install charged battery in powerpack.
	Motor has overheated	Wait until motor cools. The temperature cutout resets itself automatically. Alternatively use manual descent procedure to lower platform (Section 4.1).
Platform does not lift up from bottom of travel - motor starts		
	Driveshaft interlock is engaged	Push cordless drill on driveshaft down firmly to disengage driveshaft safety interlock.
	(If using powerpack) Powerpack driveshaft not engaged	Check powerpack is correctly fitted to platform, latch is down and drive shaft is connected to drive shaft.
	Emergency stop button is engaged (PUSHED IN) on powerpack	Disengage emergency stop button until it pops up (TURN CLOCKWISE).

Table 7-1. Troubleshooting (Continued)

TROUBLE	PROBABLE CAUSE	REMEDY
Platform will not move when in elevated position - motor starts		
	(If using powerpack) Powerpack shaft not engaged	Check powerpack charged and in correctly fitted and is fully down and latched down.
	Drive shaft malfunction	Lower platform using manual descent procedure (see Section 4.1). Refer to Authorized JLG Service Center.
Machine does not wheel properly		
	Retractable Swivel Castor is not properly deployed	With no load in the platform or on the base - lift the castor deploy handle on front of base, adjacent to platform gate. Castor should deploy and lift front of machine off adjustable feet to allow machine to roll easily on rear wheels and front castor.
	Castor is damaged	Replace castor.
Base will not level (DO NOT ELEVATE UNLESS BASE IS FIRM AND LEVEL)		
	Castor deployed (FT70 - ONLY)	With no load in platform and people clear of adjustable feet - exert approximately 55 lb. (25Kg) pressure onto front of base. Castor should retract. Adjustable feet should then be able to be used to level the machine on slopes less than 2 degrees front to back. Do not use the machine on any side slope.
Machine rocks slightly side to side		
	Support surface is not level	Only use the machine on firm and level surfaces.

SECTION 7 - TROUBLESHOOTING

Table 7-1. Troubleshooting (Continued)

TROUBLE	PROBABLE CAUSE	REMEDY
Machine rocks slightly side to side (continued)		
	Adjustable feet/casters are not BOTH in contact with supporting surface	Adjust the feet so that BOTH feet are in firm contact with supporting surface AND the machine is level.
Platform will not lift full rated load		
	Battery not fully charged	Charge or replace battery.
	Drive clutch is slipping	Contact Authorized JLG Service Center.

SECTION 8. INSPECTION AND REPAIR LOG

DATE	COMMENTS

SECTION 8 - INSPECTION AND REPAIR LOG

DATE	COMMENTS



An Oshkosh Corporation Company

Corporate Office

JLG Industries, Inc.

1 JLG Drive

McConnellsburg, PA 17233-9533 USA

☎ (717) 485-5161 (Corporate)

☎ (877) 554-5438 (Customer Support)

☎ (717) 485-6417

Visit our website for JLG Worldwide Locations.

www.jlg.com