



An Oshkosh Corporation Company

---

# ***Illustrated Parts Manual***

## ***Compact Crawler***

***X23J/2***

***X23J/3***

***X23JA/2***

***X700AJ/2***

***X700AJ/3***

---

***ANSI***



**3121604**

October 07, 2019 - Rev B



 SOTTOCARRO CINGOLATO

RAUPENFAHRWERH 

 TRACKED UNDERCARRIAGE

CARRO DE ORUGAS 



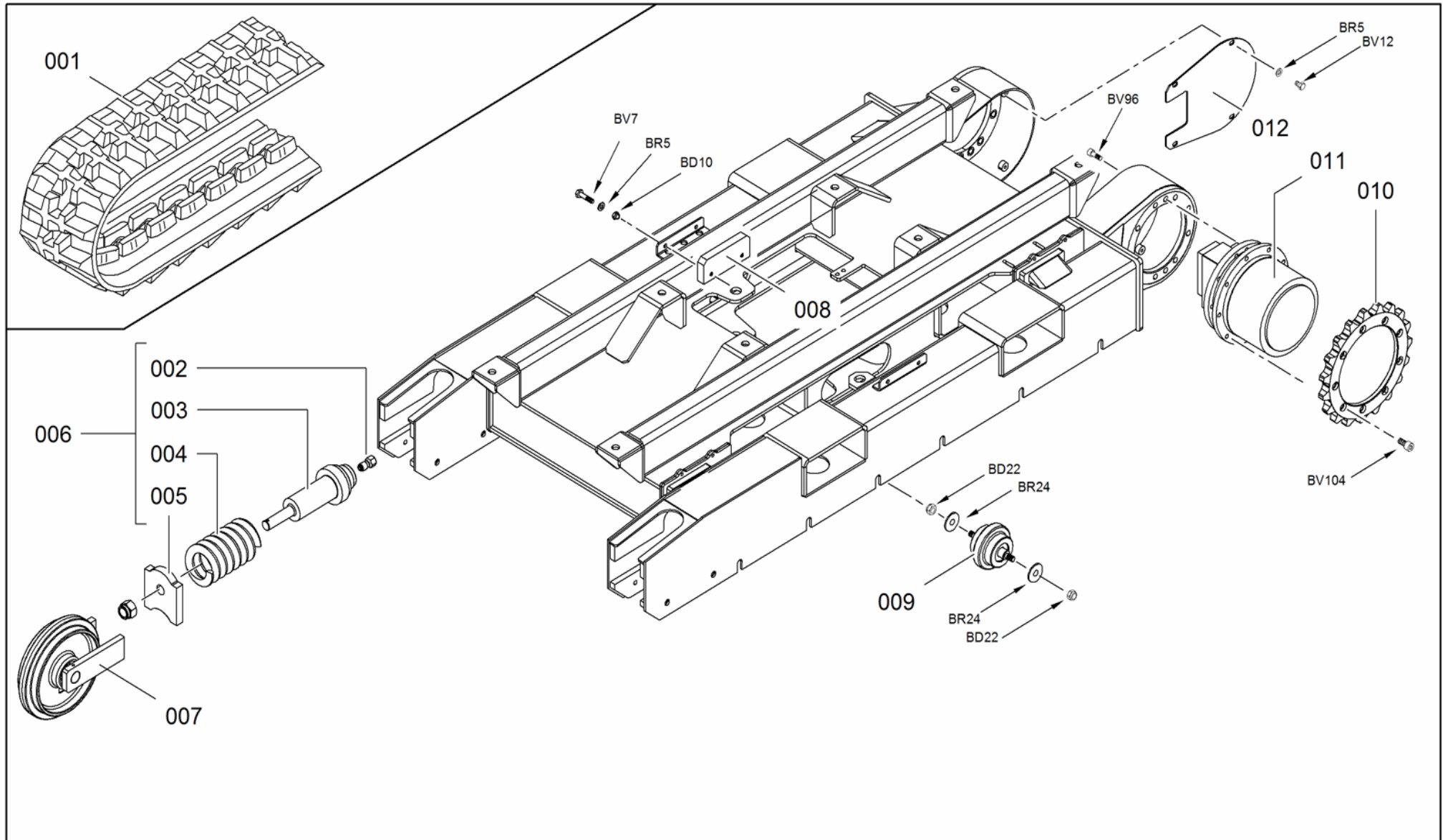

 CHENILLARD



 SOTTOCARRO CINGOLATO

 RAUPENFAHRWERK 
 TRACKED UNDERCARRIAGE

 CARRO DE ORUGAS 
 CHENILLARD

POS	Codice	Q.tà	 Descrizione	 Description	 Designation	 Benennung	 Descripción
1	04816000	2 NR	cingolo in gomma	rubber track	chenille en caoutchouc	gummiraupe	oruga de goma
1	0481600B	2 NR	cingolo in gomma	rubber track	chenille en caoutchouc	gummiraupe	oruga de goma
2	03149200	1 NR	valvola idraulica	hydraulic valve	valve hydraulique	valve hydraulique	válvula hidráulica
3	10681670	1 NR	cilindro	cylinder	vérin	zylinder	cilindro
4	03024801	1 NR	molla	spring	ressort	feder	muelle
5	04635800	1 NR	piastra	plate	platine	platte	placa
6	14730600	2 NR	supporto tendicingolo	idler support	support tendeur chenille	kettenspannhalterung	soporte tensor oruga
7	14730900	2 NR	ruota tendicingolo	idler wheel	roue tendeur de chenille	raupenspannrad	rueda tensor oruga
8	04463500	2 NR	guidacingolo	track's guide	guidage chenille	bahn für die kette	guia oruga
8	16456400	1 NR	sottocarro cingolato	tracked undercarriage	chenillard	raupenfahrwerk	carro con orugas
9	147310H2	8 NR	rullo inferiore	carrier roller	rouleau inférieur	tragrolle	rodillo inferior
10	055609H2	2 NR	ruota di trazione	sprocket wheel	roue de traction	antriebsrad	rueda de arrastre
11	264491H2	2 NR	motoriduttore	gear motor	motoréducteur	getriebemotor	motorreductor
12	063949H2	2 NR	coperchio	cover	couvercle	deckel	tapa

 SOTTOCARRO CINGOLATORAUPENFAHRWERH  TRACKED UNDERCARRIAGECARRO DE ORUGAS  CHENILLARD

POS Codice	Q.tà	 Descrizione	 Description	 Designation	 Benennung	 Descripcìon
13 03025300	2 NR	coperchio	cover	couvercle	deckel	tapa

 ALLARGAMENTO IDRAULICO

HYDR. SPURWEITENVER STELLEINRICHTUNG 



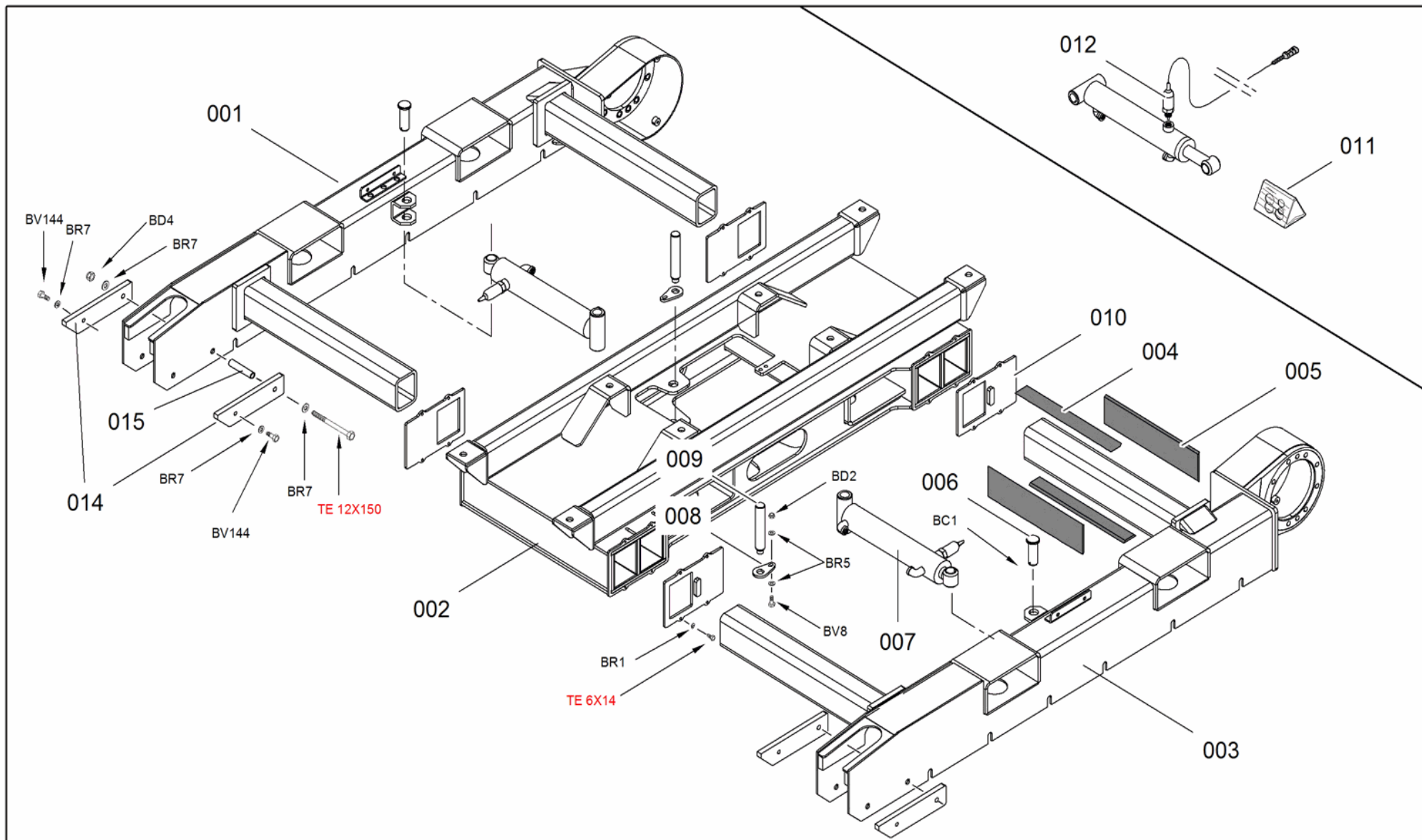

 HYDRAULIC EXTENSION

EXTENSION HIDRAULICA 

 ECARTEMENT HYDRAULIQUE



 ALLARGAMENTO IDRAULICO
HYDR. SPURWEITENVER STELLEINRICHTUNG 
 HYDRAULIC EXTENSION
EXTENSION HIDRAULICA 
 ECARTEMENT HYDRAULIQUE

POS	Codice	Q.tà	 Descrizione	 Description	 Designation	 Benennung	 Descripcìon
1	36180700	1	NR longherone destro	track frame right	longeron de droit	structure rechts	estructura lateral derecho
2	36313800	1	NR struttura	structure	structure	struktur	estructura
4	16517600	1	NR cilindro	cylinder	vérin	zylinder	cilindro
5	36180800	1	NR longherone sinistro	track frame left	longeron de gauche	structure left side	estructura lateral izquierda
6	04256300	2	NR spina	pin	cheville	stift	clavija
6	06406700	16	NR guida allargamento	expansion guide	glissière élargissement	führungsverbreiterung	guía de extensión
7	36394500	4	NR coperchio	cover	couvercle	deckel	tapa
8	1651760002	1	NR stelo	rod	tige	schaft	vástago
9	1651760009	1	NR kit guarnizioni	gasket kit	kit joints	dichtungssatz	kit guarniciones

 BASE TORRETTA

ARBEITSTURM 

 TURRET BASE



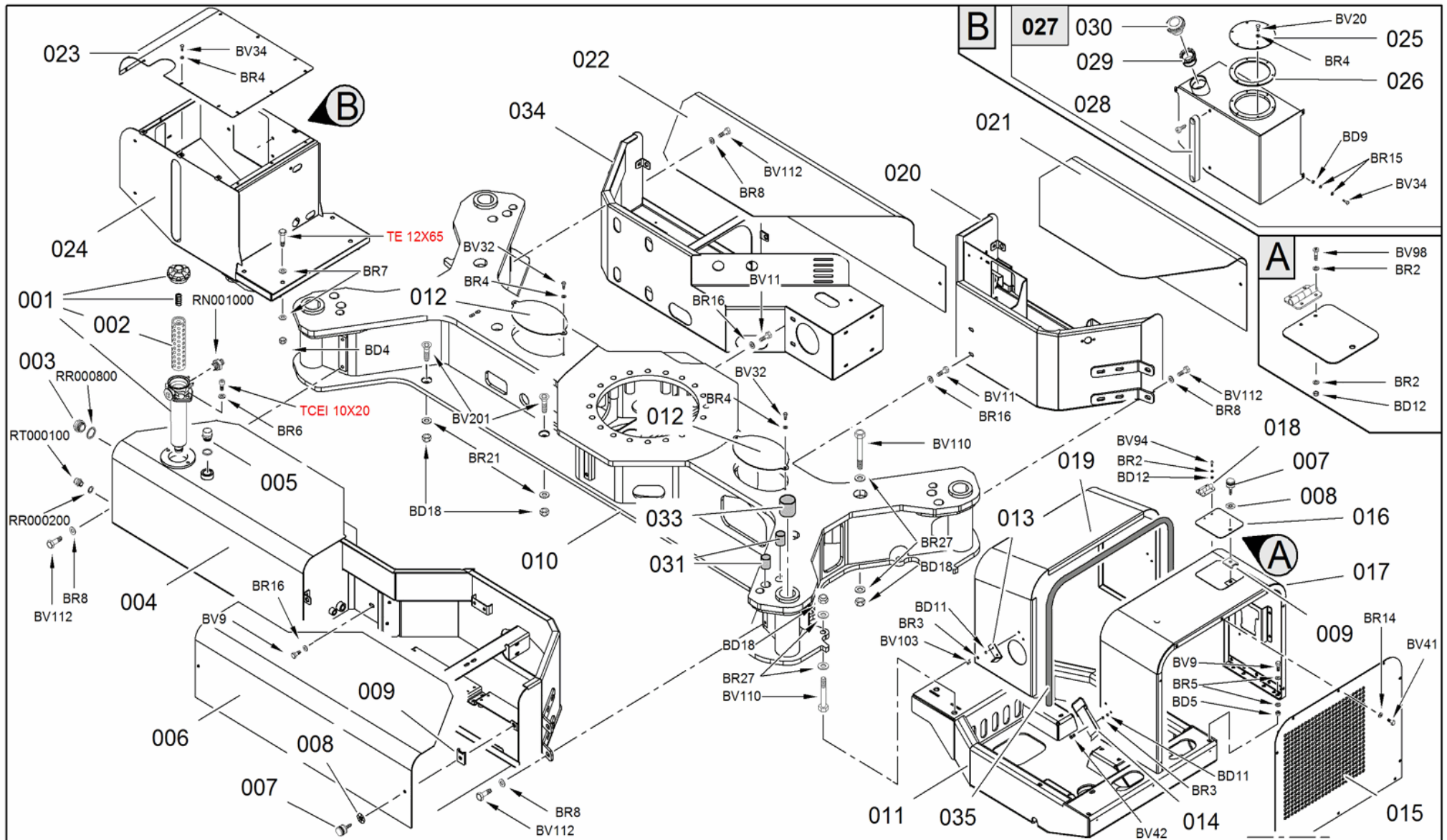

BASE TORRETTA GIRATORIA 

 BASE TOURELLE









 BASE TORRETTA
ARBEITSTURM 
 TURRET BASE
BASE TORRETA GIRATORIA 
 BASE TOURELLE

POS Codice	Q.tà	 Descrizione	 Description	 Designation	 Benennung	 Descripcìon
1 06468500	1 NR	indice allineamento	alignment indicator	indicateur d'alignement	ausrichtungsanzeig e	indicador alineación
2 05120200	1 NR	cartuccia filtro olio idraulico	oil filter insert	filtre à huile	ölfilter	filtro aceite
2 364059J0	1 NR	coperchio	cover	couvercle	deckel	tapa
3 05061800	1 NR	livello olio	oil level	niveau huile	ölstand	nivel aceite
3 364053J0	1 NR	supporto	support	support	halterung	soporte
4 163953J0	1 NR	serbatoio olio completo	complete oil tank	éservoir d'huile complet	öltank komplett	depósito de aceite compl.
5 05611800	1 NR	tappo olio	oil plug	bouchon d'huile	öldeckel	tapón aceite
5 363967J0	1 NR	supporto	support	support	halterung	caja soporte
6 36470800	1 NR	supporto	support	support	halterung	soporte
7 364701J0	1 NR	coperchio	cover	couvercle	deckel	tapa
8 05611000	6 NR	galletto	wing nut	ecrou papillon	flügelmutter	tuerca de mariposa
9 16588800	1 NR	base piattaforma	platform base	base plateforme	arbeitsbühnenunter gestell	base plataforma
10 06420400	4 NR	boccola	bush	douille	buchse	casquillo





 BASE TORRETTAARBEITSTURM  TURRET BASEBASE TORRETTA GIRATORIA  BASE TOURELLE

POS Codice	Q.tà	 Descrizione	 Description	 Designation	 Benennung	 Descripció
13 05442500	2 NR	riscontro	fastener locator	plaque pour agrafage	anschlag	gancho
13 364026J0	1 NR	supporto	support	support	halterung	soporte
14 05442600	2 NR	chiusura a gancio	hook fastening	fermeture à crochet	hakenverschluss	gancho de cierre
14 364048J0	1 NR	cofano	bonnets	capot	motorhaube	capós
15 064008J0	1 NR	coperchio	cover	couvercle	deckel	tapa
16 366011J0	1 NR	scatola componenti elettrici	electric components box	boîte composants électriques	elektrokomponente ngehäuse	caja de componentes eléctricos
17 364001J0	1 NR	supporto	support	support	halterung	soporte
17 364005J0	1 NR	supporto	support	support	halterung	soporte
18 06427700	2 NR	coperchio	cover	couvercle	deckel	tapa
19 06455100	1 NR	lamiera piegata	folded plate	tôle pliée	blech gebogen	chapa doblada
20 06455000	1 NR	lamiera piegata	folded plate	tôle pliée	blech gebogen	chapa doblada
21 163969J0	1 NR	serbatoio gasolio	diesel tank	réservoir de gasoil	dieseltank	depósito de gasóleo
22 25731300	1 NR	tappo	cap	bouchon	verschluss	tapón
23 05656400	2 NR	chiave tappo diesel	key cap diesel	clé pac	schlüssel cap	llave cap
23 05656400	1 NR	chiave tappo diesel	key cap diesel	clé pac	schlüssel cap	llave cap

 BASE TORRETTA
ARBEITSTURM 
 TURRET BASE
BASE TORRETTA GIRATORIA 
 BASE TOURELLE

POS Codice	Q.tà	 Descrizione	 Description	 Designation	 Benennung	 Descripción
24 06461300	1 NR	livello gasolio	gas oil level	niveau gasoil	kraftstoffstand	nivel gasóleo
25 064000J0	1 NR	coperchio	cover	couvercle	deckel	tapa
25 064004J0	1 NR	coperchio	cover	couvercle	deckel	tapa
26 06952600	1 NR	fermo	retainer	arrêt	halterung	bloque
27 36952200	1 NR	protezione	protection	protection	schutz	protección
28 06952500	1 NR	coperchio caricabatterie	cover battery charger	couvercle	deckel	tapa
29 06442900	1 NR	lamiera	plate	tôle	blech	chapa
30 364021J0	1 NR	supporto	support	support	halterung	soporte
31 164060J0	1 NR	protezione	protection	protection	schutz	protección
32 067251J0	1 NR	coperchio	cover	couvercle	deckel	tapa
33 36954100	1 NR	saldato cassone lithium	welded box lithium	caisson	dumpermulde	cajon
34 06955800	1 NR	coperchio	cover	couvercle	deckel	tapa
35 06976300	1 NR	piastra	plate	platine	platte	placa
36 06956500	1 NR	coperchio pacco batterie	cover battery pack	couvercle	deckel	tapa
37 06779900	1 NR	tappo ventola anteriore	cap front fan	bouchon	verschluss	tapón

 BASE TORRETTAARBEITSTURM  TURRET BASEBASE TORRETTA GIRATORIA  BASE TOURELLE

POS Codice	Q.tà	 Descrizione	 Description	 Designation	 Benennung	 Descripcìon
39 07377300	1 NR	protezione trasparente led caricabatterie pacco litio 72v	transparent protection charger led	protection transparent	transparent schutzart	protección transparente
40 04834500	1 NR	avvisatore acquistico	acoustic alarm	avertisseur sonore	hupe	avisador acústico

 BASE TORRETTA COMPONENTI ELETTRICI

BASE FRAME ELECTRICAL COMPONENTS 

 CHASSIS ELECTRICAL COMPONENTS

FRAME BASE COMPONENTES ELÉCTRICOS 

 COMPOSANTS ÉLECTRIQUES BASE FRAME

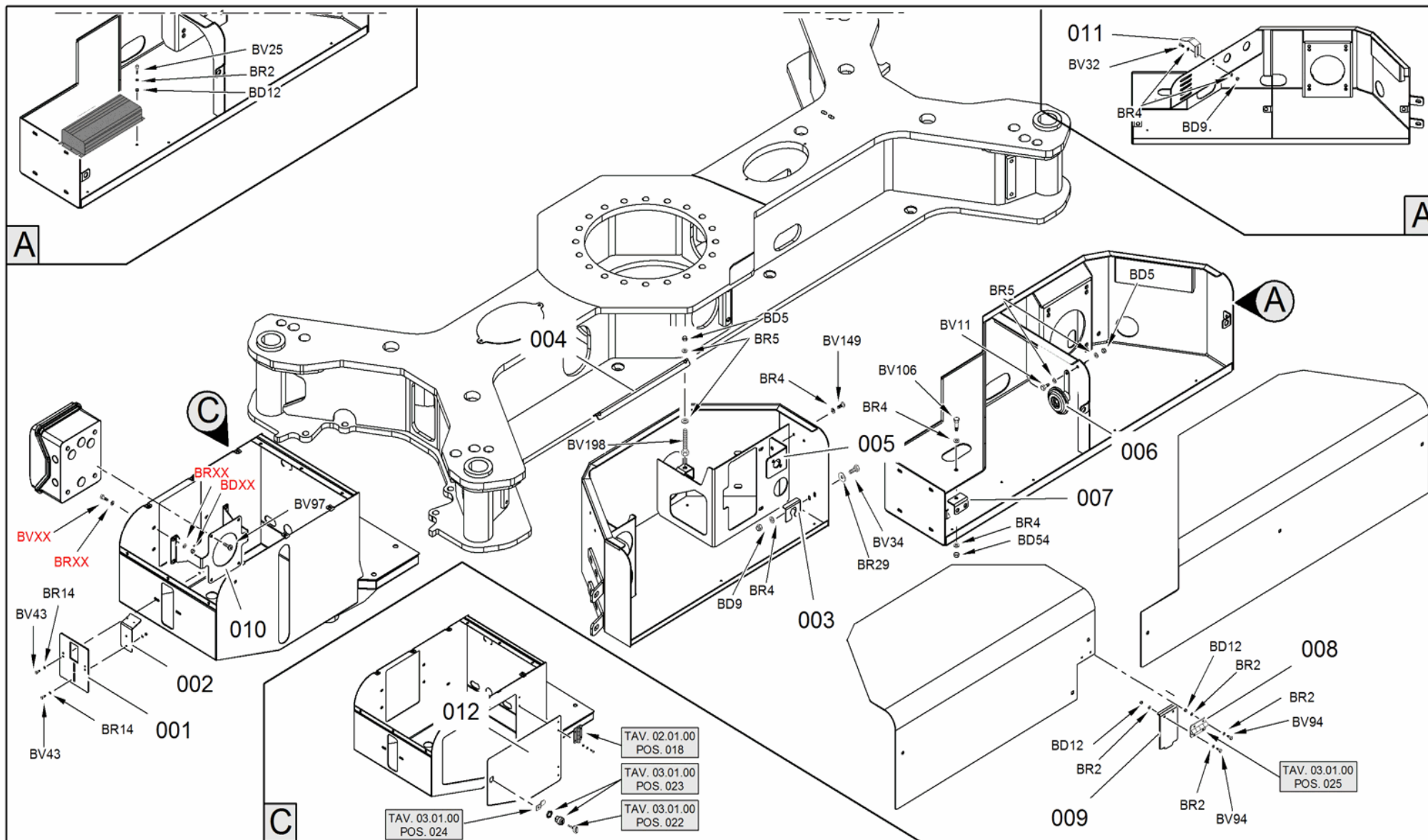





 BASE TORRETTA COMPONENTI ELETTRICI

BASE FRAME ELECTRICAL COMPONENTS 

 CHASSIS ELECTRICAL COMPONENTS

FRAME BASE COMPONENTES ELÉCTRICOS 

 COMPOSANTS ÉLECTRIQUES BASE FRAME

POS	Codice	Q.tà	 Descrizione	 Description	 Designation	 Benennung	 Descripcìon
4	15120100	1 NR	filtro olio idraulico completo	complete hydraulic oil filter	filtre à huile	ölfilter	filtro aceite
5	36395300	1 NR	serbatoio olio	oil tank	réservoir d'huile	öltank	depósito de aceite
5	363953J0	1 NR	serbatoio olio	oil tank	réservoir d'huile	öltank	depósito de aceite

 SUPPORTO BRACCI

ARMEHALTERUNG 



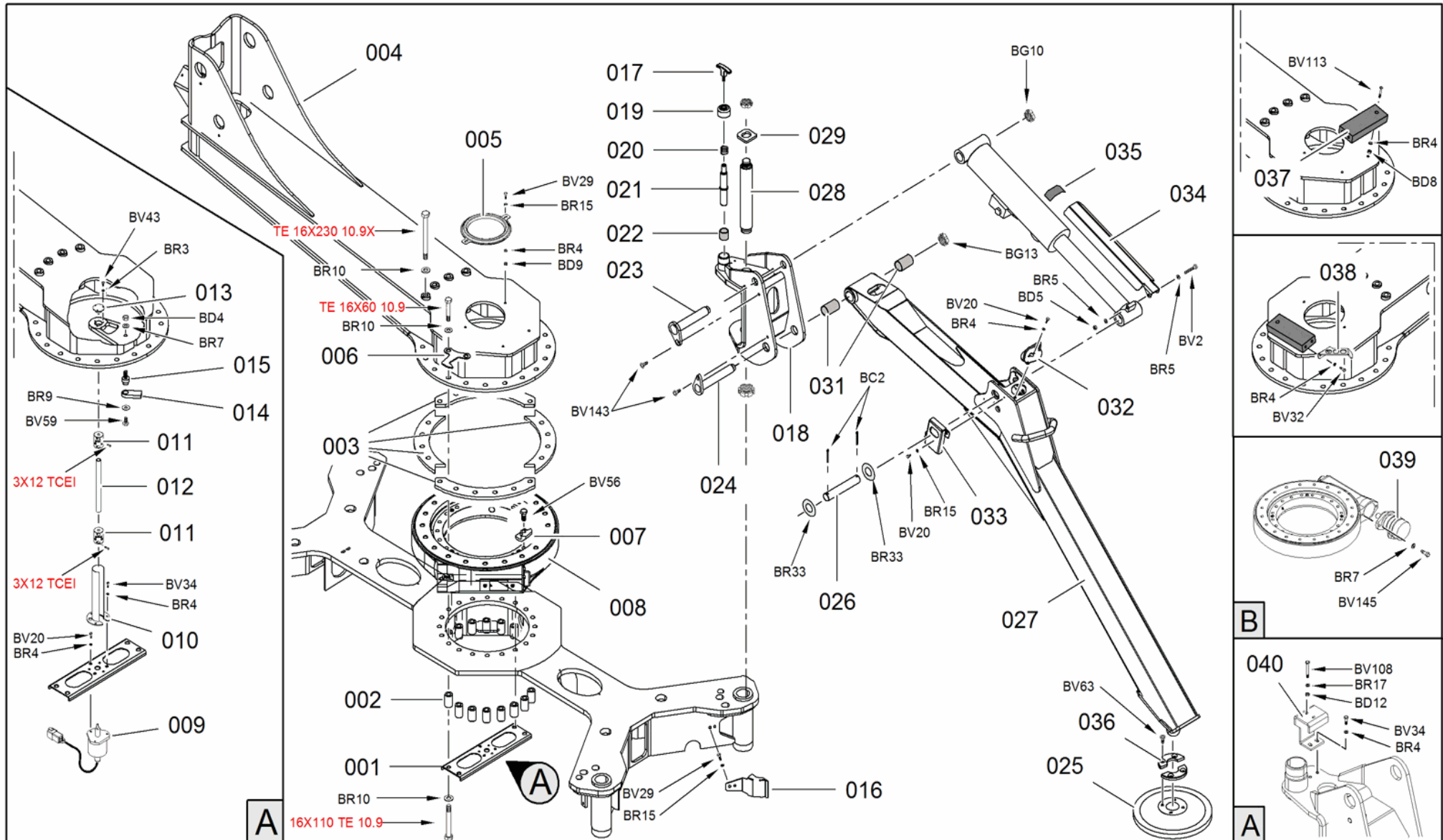

 ARMS SUPPORT

SOPORTE BRAZOS 

 SUPPORT BRAS







 SUPPORTO BRACCIARMEHALTERUNG  ARMS SUPPORTSOPORTE BRAZOS  SUPPORT BRAS





POS	Codice	Q.tà	 Descrizione	 Description	 Designation	 Benennung	 Descripción
1	364169J0	1 NR	supporto	support	support	halterung	soporte
1	364169J2	1 NR	supporto	support	support	halterung	soporte
2	06441800	1 NR	coperchio	cover	couvercle	deckel	tapa
3	05935600	1 NR	lamiera piegata	folded plate	tôle pliée	blech gebogen	chapa doblada
4	06071700	1 NR	carter	sump	carter	kurbelgehäuse	cárter
4	37178600	1 NR	carter protezione distributore bracci versione ce	cover for distributor arms ce version	carter	kurbelgehäuse	cárter
5	06543000	2 NR	spessore	thickness	cale	stärke	espesor
6	06543100	2 NR	spessore	thickness	cale	stärke	espesor
7	264593H2	1 NR	ralla	fifth wheel	couronne dentée	drehkranz	tejuelo
8	06551100	1 NR	fermo	retainer	arrêt	halterung	bloque
9	067463Y1	1 NR	supporto	support	support	halterung	soporte
10	06459100	1 NR	boccola	bush	douille	buchse	casquillo
11	06478700	4 NR	spina	pin	cheville	stift	clavija
12	16274900	4 NR	snodo	articulation	articulation	gelenk	articulación
13	06588500	4 NR	spina	pin	cheville	stif	clavija



 SUPPORTO BRACCI
ARMEHALTERUNG 
 ARMS SUPPORT
SOPORTE BRAZOS 
 SUPPORT BRAS

POS Codice	Q.tà	 Descrizione	 Description	 Designation	 Benennung	 Descripción
14 06600800	4 NR	molla	spring	ressort	feder	muelle
15 06588700	4 NR	coperchio	cover	couvercle	deckel	tapa
17 06478600	4 NR	spina	pin	cheville	stif	clavija
17 06520700	4 NR	maniglia	handle	poignée	griff	manija
18 07495600	0,28 NR	gomma adesiva di protezione	rubber adhesive protection	gomme adhesive de protection	schutz-klebegummi	goma adhesiva de protección
18 07495600	0,6 NR	gomma adesiva di protezione	rubber adhesive protection	gomme adhesive de protection	schutz-klebegummi	goma adhesiva de protección
19 06406400	2 NR	carter	sump	carter	kurbelgehäuse	cárter
20 06401900	2 NR	carter	sump	carter	kurbelgehäuse	cárter
21 06588600	4 NR	supporto	support	support	halterung	soporte
22 06422000	2 NR	boccola	bush	douille	buchse	casquillo
23 16271600	4 NR	stabilizzatore	stabilizer	stabilisateur	stabilizer	estabilizador
23 162716J0	4 NR	stabilizzatore	stabilizer	stabilisateur	stabilizer	estabilizador
24 06275000	4 NR	spina	pin	cheville	stift	clavija
25 05446300	4 NR	disco	disk	disque	scheibe	disco
25 36401700	4 NR	carter	sump	carter	kurbelgehäuse	cárter
26 05446400	8 NR	semiflangia	half flange	demi-bride	halb flansch	semi brida

 SUPPORTO BRACCI
ARMEHALTERUNG 
 ARMS SUPPORT
SOPORTE BRAZOS 
 SUPPORT BRAS

POS Codice	Q.tà	 Descrizione	 Description	 Designation	 Benennung	 Descripción
28 05625800	4 NR	piastrina	plate	plaquette	plättchen	placa
29 05562900	1 NR	staffa	bracket	étrier	haltebügel	estribo
30 05333300	8 NR	collare	clamp	collar	collar	collar
31 26130800	1 NR	motore di rotazione	rotary motor	moteur de rotation	rotationsmotor	motor de rotación
32 064422Y1	1 NR	fermo	retainer	arrêt	halterung	bloque
33 064423Y1	1 NR	perno	pin	goujon	zapfen	pernio
34 06551600	38 NR	pinza	pliers	pince	klemme	pinza
35 36281200	1 NR	protezione	protection	protection	schutz	protección
36 06680400	1 NR	sensore	sensor	capteur	sensor	sensor
37 367460Y1	1 NR	protezione	protection	protection	schutz	protección
38 26741500	2 NR	giunto	coupling	joint	verbindung	acoplamiento
39 06745900	1 NR	tubo	pipe	tuyau	rohr	tubo
40 067464Y1	1 NR	riscontro	fastener locator	plaque pour agrafage	anschlag	gancho
41 07178700	2 NR	cerniera con controllo della posizione	hinges with position control	charnière	scharnier	cable charnela





 SUPPORTO BRACCI

ARMEHALTERUNG 

 ARMS SUPPORT

SOPORTE BRAZOS 

 SUPPORT BRAS

POS Codice	Q.tà	 Descrizione	 Description	 Designation	 Benennung	 Descripción
42 07189700	1 NR	coperchio carter distributore bracci versione ce	crankcase cover distributor arm ce version	couvercle	deckel	tapa
48 17283500	1 NR	kit ganci sollevamento	kit lifting hooks	kit crochets de levage	kit heisshakens	kit ganchos de elevación

 PRIMO BRACCIO

ERSTER AUSLEGERARM 



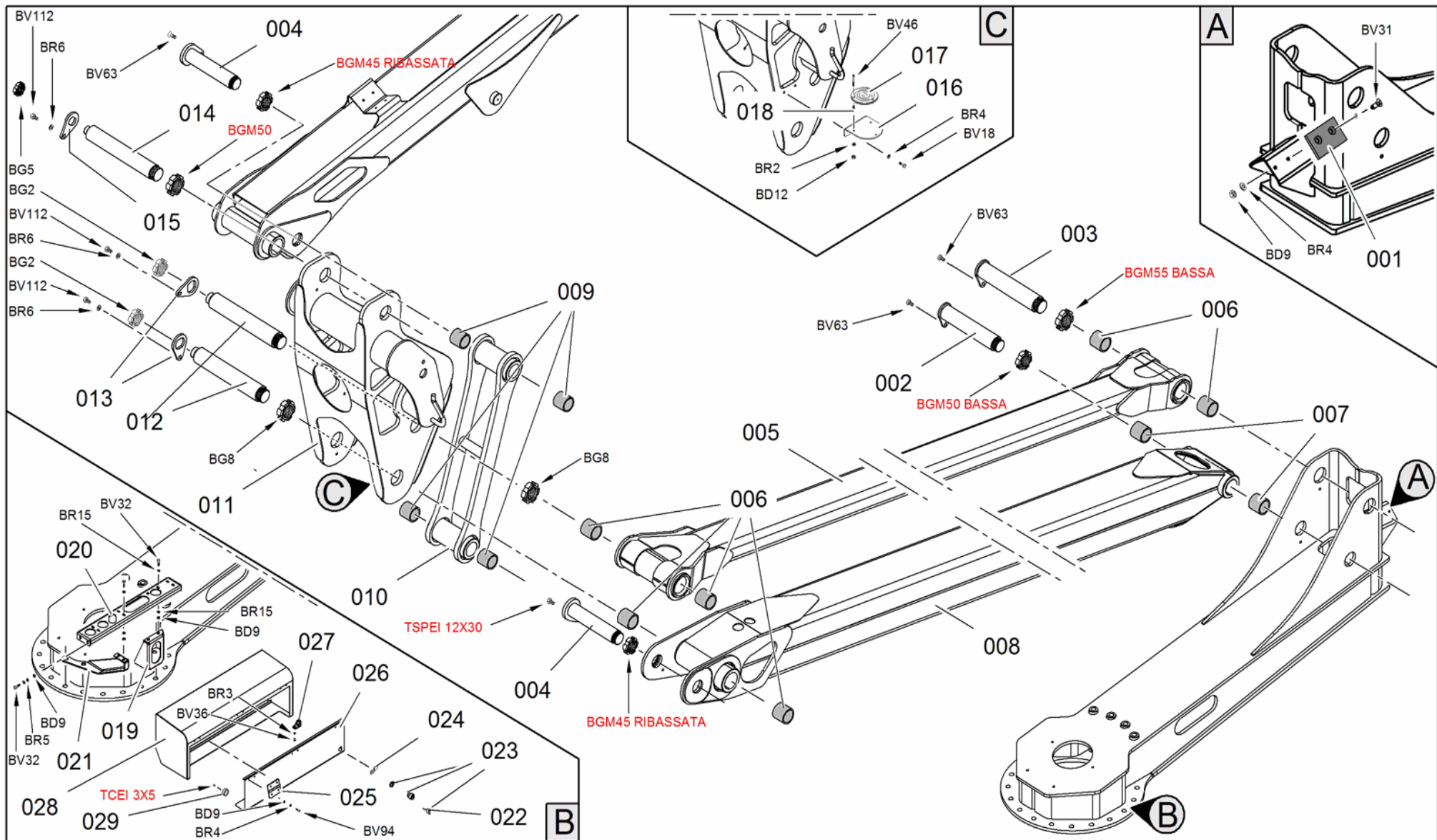

 FIRST ARM

PRIMO BRAZO 





 PREMIER BRAS



 PRIMO BRACCIO
ERSTER AUSLEGERARM 
 FIRST ARM
PRIMO BRAZO 
 PREMIER BRAS

POS	Codice	Q.tà	 Descrizione	 Description	 Designation	 Benennung	 Descripción
1	06478400	1 NR	spina	pin	cheville	stift	clavija
2	06478500	1 NR	spina	pin	cheville	stift	clavija
3	164180J0	1 NR	primo braccio	first arm	premier bras	erster auslegerarm	primo brazo
3	164180J2	1 NR	primo braccio	first arm	premier bras	erster auslegerarm	primo brazo
4	06420200	2 NR	boccola	bush	douille	buchse	casquillo
5	164201J0	1 NR	tirante	tie rod	tirant	turmgestänge	tirante
5	164201J2	1 NR	tirante	tie rod	tirant	turmgestänge	tirante
6	06434200	4 NR	boccola	bush	douille	buchse	casquillo
7	06492900	1 NR	spina	pin	cheville	cheville	clavija
8	06479000	1 NR	spina	pin	cheville	stift	clavija
9	06478900	1 NR	spina	pin	cheville	stift	clavija
10	06420300	2 NR	boccola	bush	douille	buchse	casquillo
11	06494500	1 NR	piatto	plate	plateau	platte	placa
12	06493300	1 NR	spina	pin	cheville	cheville	clavija
13	06420900	4 NR	boccola	bush	douille	buchse	casquillo

 PRIMO BRACCIO
ERSTER AUSLEGERARM 
 FIRST ARM
PRIMO BRAZO 
 PREMIER BRAS

POS Codice	Q.tà	 Descrizione	 Description	 Designation	 Benennung	 Descripción
14 164205J0	1 NR	biella	connecting rod	bielle	zeitsteuerungsverbi ndung	biela
14 164205J2	1 NR	biella	connecting rod	bielle	zeitsteuerungsverbi ndung	biela
15 364237J0	1 NR	rinvio	transmission	renvoi	vorgelege	reenvio
15 364237J2	1 NR	rinvio	transmission	renvoi	vorgelege	reenvio
16 06455300	1 NR	tampone	pad	tampon	puffer	tampón
17 05427200	1 NR	livella	level	niveau	wasserwaage	nivel de burbuja
17 05967800	1 NR	indice allineamento	alignment indicator	indicateur d'alignement	ausrichtungsanzeig e	indicador alineación
18 05444800	3 NR	molla	spring	ressort	feder	muelle
18 06455400	2 NR	tampone	pad	tampon	puffer	tampón
22 07298800	1 NR	chiave per serratura postazione comando a terra	key to the lock on the ground control position	clef	chlüssel	clave
23 07178800	1 NR	serratura	lock	serrure	schloss	cerradura
24 07178900	1 NR	camma per serratura disassamento 3.2	cam lock for offset 3.2	came	nocken	leva

 SECONDO BRACCIO

SECOND BRAS 



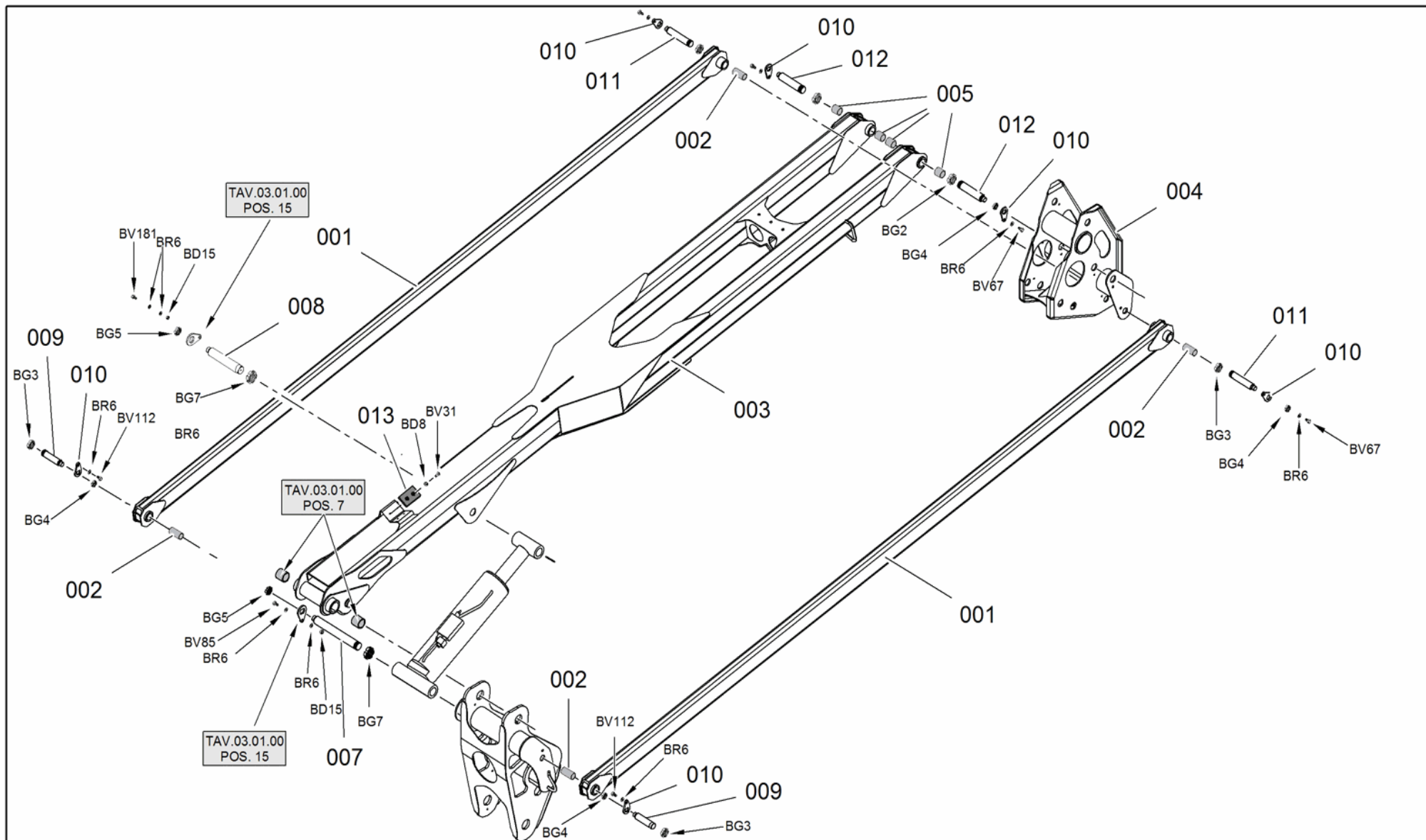

 SECOND ARM

TWEEDE ARM 

 ZWEITER AUSLEGERARM







 SECONDO BRACCIO
SECOND BRAS 
 SECOND ARM
TWEEDE ARM 
 ZWEITER AUSLEGERARM

POS	Codice	Q.tà	 Descrizione	 Description	 Designation	 Benennung	 Descripción
1	164210J0	1 NR	secondo braccio	second arm	second bras	zweiter auslegerarm	segundo brazo
1	164210J2	1 NR	secondo braccio	second arm	second bras	zweiter auslegerarm	segundo brazo
2	06326300	4 NR	boccola	bush	douille	buchse	casquillo
3	06456000	2 NR	tampone	pad	tampon	puffer	tampón
4	06422100	2 NR	boccola	bush	douille	luftöffnung	boquilla aire
5	06493100	2 NR	spina	pin	cheville	cheville	clavija
6	163129J0	2 NR	tirante	tie rod	tirant	turmgestänge	tirante
6	163129J2	2 NR	tirante	tie rod	tirant	turmgestänge	tirante
7	06461500	2 NR	boccola	bush	douille	buchse	casquillo
10	058832H3	1 NR	supporto	support	support	halterung	soporte
11	06493000	1 NR	spina	pin	cheville	cheville	clavija
12	06493200	1 NR	spina	pin	cheville	cheville	clavija
13	06493400	1 NR	spina	pin	cheville	cheville	clavija
14	06493600	2 NR	spina	pin	cheville	stif	clavija
15	06478700	6 NR	spina	pin	cheville	stift	clavija



 SECONDO BRACCIOSECOND BRAS  SECOND ARMTWEEDE ARM  ZWEITER AUSLEGERARM

POS Codice	Q.tà	 Descrizione	 Description	 Designation	 Benennung	 Descripcìon
16 363114J0	1	NR rinvio	transmission	renvoi	vorgelege	reenvio
16 363114J2	1	NR rinvio	transmission	renvoi	vorgelege	reenvio

 TERZO BRACCIO

DRITTER AUSLEGERARM 

 THIRD ARM

TERCER BRAZO 



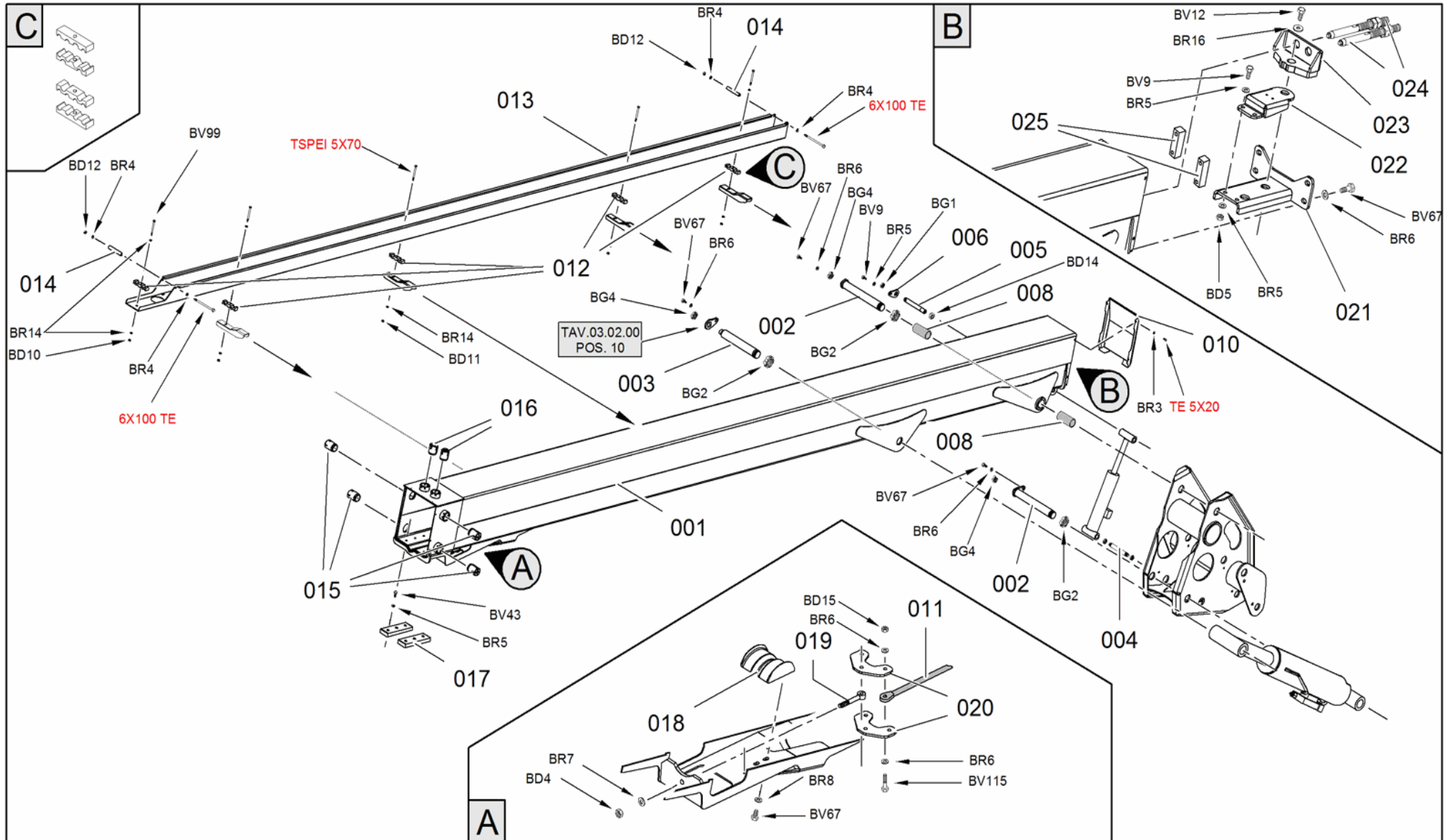

 TROISIÈME BRAS



 TERZO BRACCIO

 DRITTER AUSLEGERARM 
 THIRD ARM





 TERCER BRAZO 
 TROISIÈME BRAS

POS	Codice	Q.tà	 Descrizione	 Description	 Designation	 Benennung	 Descripcìon
1	163079J0	1 NR	terzo braccio	third arm	troisième bras	dritter auslegerarm	tercer brazo
1	163079J2	1 NR	terzo braccio	third arm	troisième bras	dritter auslegerarm	tercer brazo
2	06643100	1 NR	lamiera	plate	tôle	blech	chapa
3	06493900	1 NR	spina	pin	cheville	cheville	clavija
4	06493700	1 NR	spina	pin	cheville	cheville	clavija
5	06493800	1 NR	spina	pin	cheville	cheville	clavija
6	06236600	1 NR	spina	pin	cheville	cheville	clavija
6	06496500	11 NR	goccia spina	pin drop	baisse cheville	tropfen stift	caída clavija
7	06422200	2 NR	boccola	bush	douille	buchse	casquillo
8	06494000	1 NR	spina	pin	cheville	cheville	clavija
9	06551700	1 NR	carter	sump	carter	kurbelgehäuse	cárter
10	06306000	1 NR	supporto	support	support	halterung	soporte
11	06518900	3 NR	tirante	tie rod	tirant	turmgestänge	tirante
12	06518300	1 NR	pattino	slide block	patin	gleitblock	patín
13	06311000	1 NR	supporto	support	support	halterung	soporte

 TERZO BRACCIO

 DRITTER AUSLEGERARM 
 THIRD ARM

 TERCER BRAZO 
 TROISIÈME BRAS

POS Codice	Q.tà	 Descrizione	 Description	 Designation	 Benennung	 Descripción
14 06304200	4 NR	pattino	slide block	patin	gleitblock	patín
14 06518800	2 NR	distanziale	spacer	entretoise	distanzstück	distanciador
15 06301200	12 NR	pattino	slide block	patin	gleitblock	patín
16 06306200	1 NR	slitta	slide	coulisseau	schlitten	corredera
17 063063H3	2 NR	piatto	plate	plateau	platte	placa
18 06457600	2 NR	fune	cable	câble	seil	cable
19 06458000	1 NR	tirante	tie rod	tirant	turmgestänge	tirante
20 363078Y1	1 NR	supporto	support	support	halterung	soporte
21 063061Y1	1 NR	supporto	support	support	halterung	soporte
22 363074Y1	1 NR	bilancere	rocker arm	balancier	kipphebel	balancín
23 06456500	2 NR	fune	cable	câble	seil	cable

 PRIMO SFILÒ

ERSTER TELESKOPARM 

 FIRST EXTENSION ARM

PRIMO BRAZO DE EXTENSION 



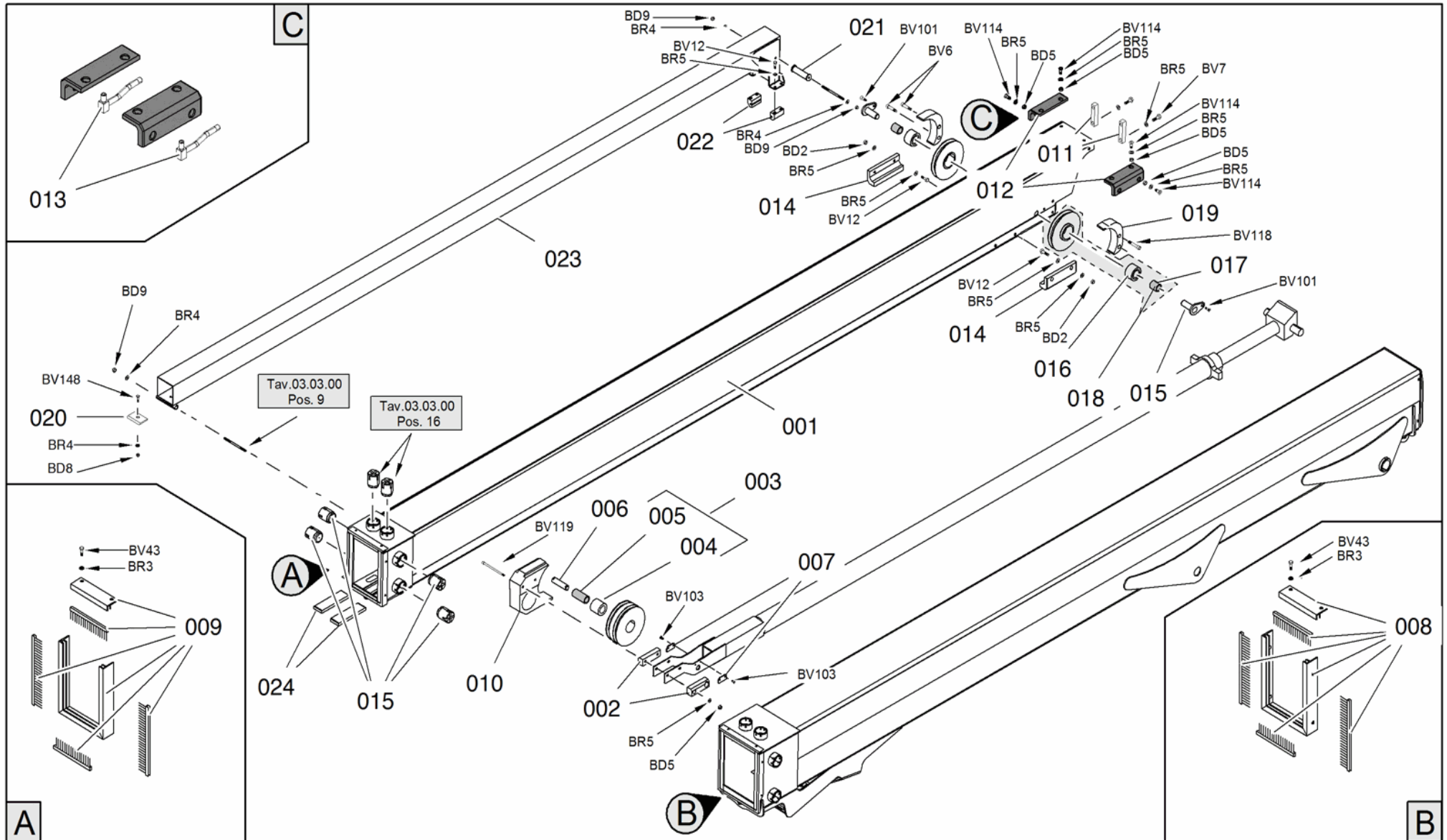

 PREMIER BRAS D'EXTRACTION



 PRIMO SFILLO
ERSTER TELESKOPARM 
 FIRST EXTENSION ARM
PRIMO BRAZO DE EXTENSION 
 PREMIER BRAS D'EXTRACTION

POS Codice	Q.tà	 Descrizione	 Description	 Designation	 Benennung	 Descripción
1 06308100	2 NR	piatto	plate	plateau	platte	placa
2 06308800	2 NR	pattino	slide block	patin	gleitblock	patín
3 16510800	1 NR	puleggia	pulley	poulie	scheibe	polea
4 06321100	1 NR	boccola	bush	douille	buchse	casquillo
5 06422400	1 NR	boccola	bush	douille	buchse	casquillo
6 06309900	1 NR	spina	pin	cheville	cheville	clavija
7 06308700	1 NR	pattino	slide block	patin	gleitblock	patín
8 06297100	2 NR	pattino	slide block	patin	gleitblock	patín
9 06433400	2 NR	pattino	slide block	patin	gleitblock	patín
10 16510900	2 NR	puleggia	pulley	poulie	scheibe	polea
11 06308900	2 NR	spina	pin	cheville	stif	clavija
14 06300700	2 NR	piatto	plate	plateau	platte	placa
15 06433500	4 NR	pattino	slide block	patin	gleitblock	patín
16 06304000	4 NR	piatto	plate	plateau	platte	placa
16 06321200	1 NR	boccola	bush	douille	buchse	casquillo
17 06422300	1 NR	boccola	bush	douille	buchse	casquillo

 PRIMO SFILLO
ERSTER TELESKOPARM 
 FIRST EXTENSION ARM
PRIMO BRAZO DE EXTENSION 
 PREMIER BRAS D'EXTRACTION

POS Codice	Q.tà	 Descrizione	 Description	 Designation	 Benennung	 Descripción
18 06539600	1 NR	rullo	roller	rouleau	rolle	rodillo
19 36519000	1 NR	supporto	support	support	halterung	soporte
20 06586300	1 NR	pattino	slide block	patin	gleitblock	patín
20 362954J0	1 NR	sfillo	extension arm	bras d'extraction	teleskoparm	brazo de extensión
21 06539700	1 NR	rullo	roller	rouleau	rolle	rodillo
21 06586800	2 NR	spazzola	brush	brosse	bürste	cepillo
22 06586600	1 NR	lamiera	plate	tôle	blech	chapa
23 06586900	2 NR	spazzola	brush	brosse	bürste	cepillo
24 06586400	1 NR	lamiera piegata	folded plate	tôle pliée	blech gebogen	chapa doblada
25 16587200	1 NR	kit spazzole	brushes kit	kit de brosses	bürstensatz	kit de cepillos
26 06586500	1 NR	lamiera piegata	folded plate	tôle pliée	blech gebogen	chapa doblada
27 06586700	1 NR	lamiera piegata	folded plate	tôle pliée	blech gebogen	chapa doblada
28 06587100	2 NR	spazzola	brush	brosse	bürste	cepillo
29 06587000	2 NR	spazzola	brush	brosse	bürste	cepillo
30 16587300	1 NR	kit spazzole	brushes kit	kit de brosses	bürstensatz	kit de cepillos

 SECONDO SFILLO

ZWEITER TELESKOPARM 

 SECONDO EXTENSION ARM



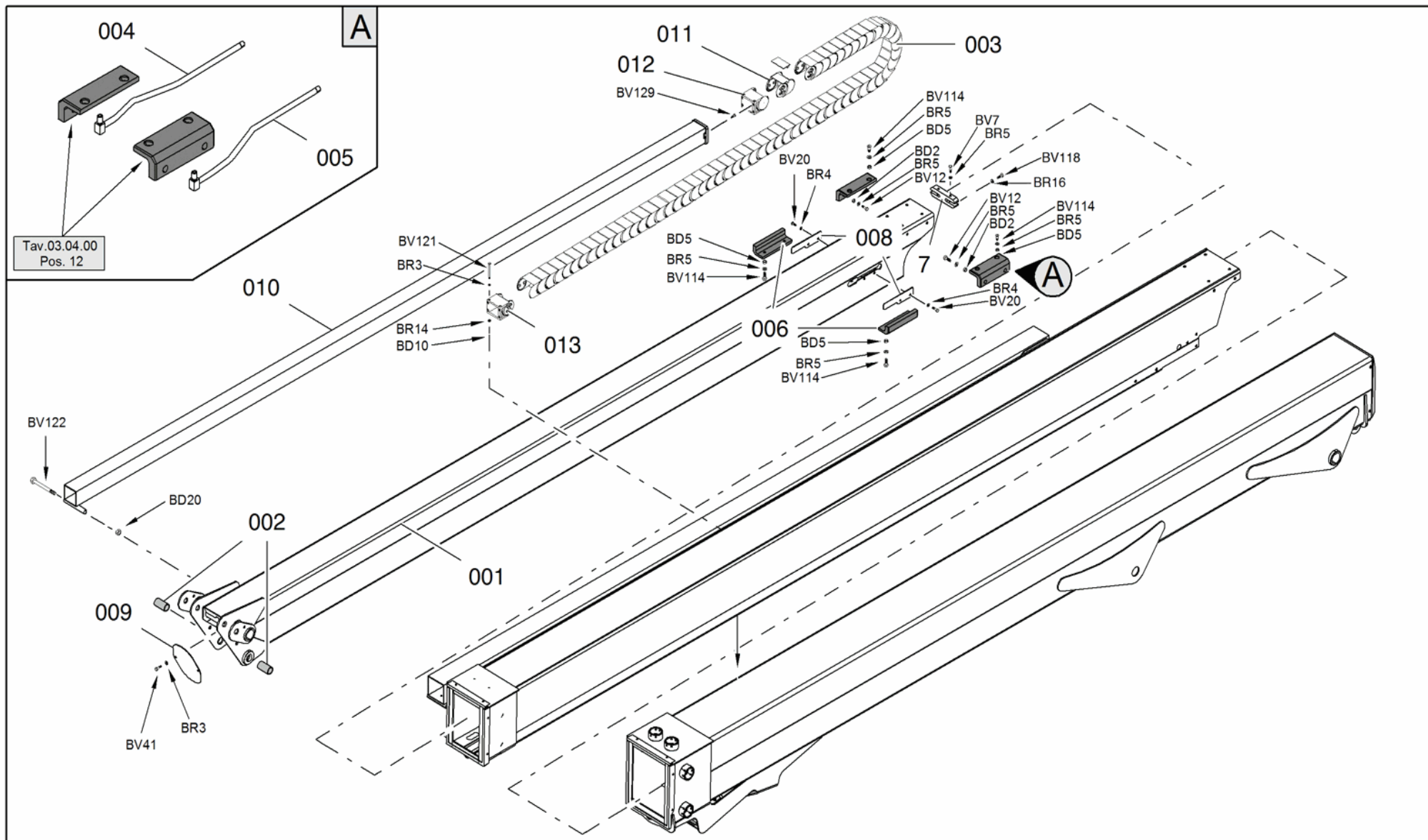

SEGUNDO BRAZO TELESCÓPICO 

 DEUXIÈME BRAS D'EXTRACTION





 SECONDO SFILLO
ZWEITER TELESKOPARM 
 SECONDO EXTENSION ARM
SEGUNDO BRAZO TELESCÓPICO 
 DEUXIÈME BRAS D'EXTRACTION

POS Codice	Q.tà	 Descrizione	 Description	 Designation	 Benennung	 Descripción
1 06305900	5 NR	morsetto	clamp	borne	klemme	borne
2 26461600	1 NR	catena portacavi	cable-holder chain	chaîne porte-câbles	kabelhalterkette	cadena portacables
3 2646160001	1 NR	coperchio catena portacavi	cover cable-holder chain	couvercle	deckel	tapa
4 2646160002	1 NR	attacco femmina catena portacavi	female coupling cable-holder chain	raccord femelle	aufsteckanschluss	empalme hembra
5 2646160003	1 NR	maglia catena portacavi	cable-holder chain link	maillot chaîne	kettenglied	eslabón cadena
6 2646160004	1 NR	attacco maschio catena portacavi	male coupling cable-holder chain	raccord mâle	steckanschluss	empalme macho
7 06296200	1 NR	piastra	plate	platine	platte	placa
8 062967Y1	2 NR	coperchio	cover	couvercle	deckel	tapa
9 06296100	2 NR	pattino	slide block	patin	gleitblock	patín
10 162955J0	1 NR	sfillo	extension arm	bras d'extraction	teleskoparm	brazo de extensión
11 36540200	1 NR	supporto	support	support	halterung	soporte
12 06272600	4 NR	boccola	bush	douille	buchse	casquillo
13 06442800	1 NR	carter	sump	carter	kurbelgehäuse	cárter

 SUPPORTO CESTO

ARMEHALTERUNG 



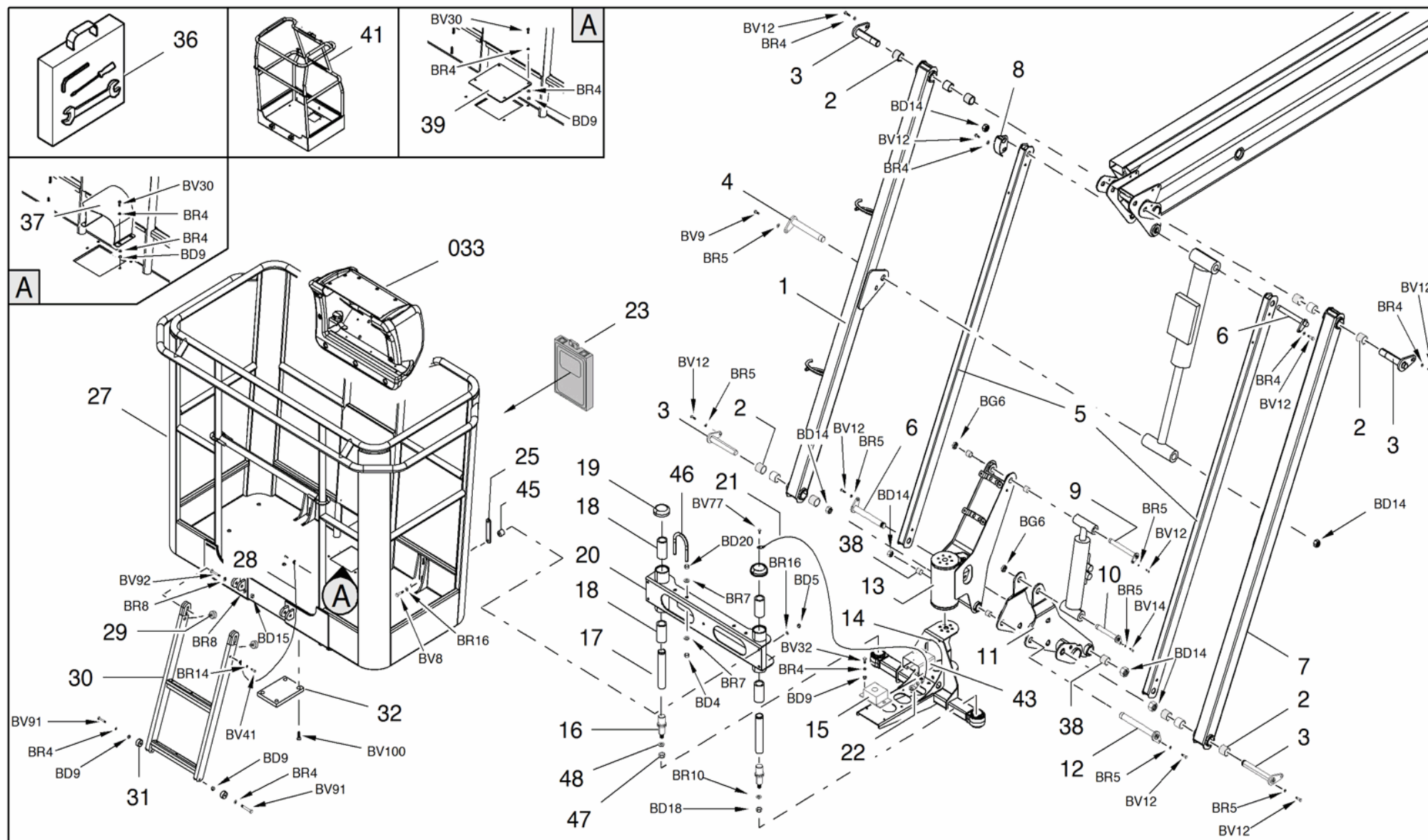

 ARMS SUPPORT

SUPORTE BRAZOS 





 SUPPORT BRAS







 SUPPORTO CESTO
ARMEHALTERUNG 
 ARMS SUPPORT
SUPORTE BRAZOS 
 SUPPORT BRAS

POS	Codice	Q.tà	 Descrizione	 Description	 Designation	 Benennung	 Descripción
1	164392J0	1 NR	braccio jib	jib arm	fléchette bras	arm - schwenkarm	brazo jib
2	06272600	2 NR	boccola	bush	douille	buchse	casquillo
3	06494100	4 NR	spina	pin	cheville	cheville	clavija
4	06494300	1 NR	spina	pin	cheville	cheville	clavija
5	359447J0	2 NR	tirante jib	tie rod jib	tirant	turmgestänge	tirante
6	06494200	2 NR	spina	pin	cheville	cheville	clavija
7	164393J0	1 NR	braccio jib	jib arm	fléchette bras	arm - schwenkarm	brazo jib
8	06272700	2 NR	boccola	bush	douille	buchse	casquillo
9	06494800	1 NR	spina	pin	cheville	cheville	clavija
10	06494600	1 NR	spina	pin	cheville	cheville	clavija
11	164704J0	1 NR	rinvio	transmission	renvoi	vorgelege	reenvio
12	06494700	1 NR	spina	pin	cheville	cheville	clavija
13	2648910002	1 NR	kit guarnizioni	seal kit	trousse de joint	dichtung kit	kit de juntas
13	264891J0	1 NR	motore di rotazione	rotary motor	moteur de rotation	rotationsmotor	motor de rotación
14	359442J0	1 NR	supporto	support	support	halterung	soporte





 SUPPORTO CESTO
ARMEHALTERUNG 
 ARMS SUPPORT
SUPORTE BRAZOS 
 SUPPORT BRAS

POS Codice	Q.tà	 Descrizione	 Description	 Designation	 Benennung	 Descripción
15 05618700	1 NR	coperchio	box	couvercle	deckel	tapa
15 056187H3	1 NR	coperchio	box	couvercle	deckel	tapa
16 05863700	2 NR	perno supporto cesto (fornito a ricambio assemblato al tubo 05863600)	pin holder basket (spare parts provided assembled with tube 05863600)	goujon	zapfen	pernio
17 05863600	2 NR	tubo supporto cesto (fornito a ricambio assemblato al perno 05863700)	tube basket holder (spare parts provided assembled with the pin 05863700)	tuyau rigide	rohr	tubo rígido
18 26084300	4 NR	cuscinetto	bearing	coussinet	lager	cojinete
19 06058300	2 NR	tappo	cap	bouchon	verschluss	tapón
20 36057800	1 NR	slitta	slide	coulisseau	schlitten	corredera
21 06665000	2 NR	fune	cable	câble	seil	cable
22 07052900	1 NR	staffa	bracket	étrier	haltebügel	estribo
23 05643600	1 NR	cassetta portamanuale	manual box	boîte porte-manuel	bedienungsanleitung gsfach	caja portamanual





 SUPPORTO CESTO
ARMEHALTERUNG 
 ARMS SUPPORT
SUPORTE BRAZOS 
 SUPPORT BRAS

POS Codice	Q.tà	 Descrizione	 Description	 Designation	 Benennung	 Descripción
24 06477600	1 NR	magnete ø20 con foro m3	magneto ø20 with m3 hole	aimant	magnet	imán
24 06477600	2 NR	magnete ø20 con foro m3	magneto ø20 with m3 hole	aimant	magnet	imán
25 06613300	1 NR	piastra	plate	platine	platte	placa
25 07239800	2 NR	piastra fissaggio cesto (solo macchine modello jp e ja e x17j)	fixing plate basket (only machines model jp and ja and x17j)	plate fixation drum	plate befestigung drum	placa fijación tambor
26 07298800	1 NR	chiave per serratura postazione comando a terra	key to the lock on the ground control position	clef	chlüssel	clave
26 16602500	1 NR	protezione	protection	protection	schutz	protección
27 26602600	1 NR	cesto 2 persone	two-person basket	panier 2 personnes	2 mann-arbeitskorb	cesta 2 personas
27 27177700	1 NR	cesto biposto 230kg (solo macchine modello jp e ja)	basket 2 person 230kg (only machines model jp and ja)	panier 2 personnes	2 mann-arbeitskorb	cesta 2 personas
28 06598500	1 NR	fune	cable	câble	seil	cable
29 05475900	2 NR	antivibrante	anti-vibrating	anti - vibrant	vibrationsdämpfer	antivibrante
30 36585800	1 NR	scaletta	ladder	échelle repliable	leiter	escalera plegable

 SUPPORTO CESTO
ARMEHALTERUNG 
 ARMS SUPPORT
SUPORTE BRAZOS 
 SUPPORT BRAS

POS Codice	Q.tà	 Descrizione	 Description	 Designation	 Benennung	 Descripción
31 06585900	2 NR	rotellina	small roller	roulette	rädchen	ruedecilla
32 058600H3	1 NR	piastra	plate	platine	platte	placa
37 06418600	1 NR	protezione	protection	protection	schutz	protección
38 06272700	2 NR	boccola	bush	douille	buchse	casquillo
40 17324400	1 NR	cesto 1 persona	one-person basket	panier 1 personne	1 mann-arbeitskorb	cesta 1 persona
40 26702400	1 NR	cesto 1 persona	one-person basket	panier 1 personne	1 mann-arbeitskorb	cesta 1 persona
41 07031800	2 NR	tubo	pipe	tuyau	rohr	tubo
43 06412400	1 NR	lamiera piegata	folded plate	tôle pliée	blech gebogen	chapa doblada
44 06470700	1 NR	slitta	slide	coulisseau	schlitten	corredera
45 07239700	2 NR	distanziale per viti m8 supporto cesto (solo macchine modello jp e ja e x17j)	spacer screw m8 support basket (only machines model jp and ja and x17j)	spacer par vis	spacer per schrauben	separador por tornillos
45 17287100	1 NR	kit ferma cesto (solo macchine versione australia)	lock kit basket (only australian version machines)	arrêt	halterung	bloque

 SUPPORTO CESTO
ARMEHALTERUNG 
 ARMS SUPPORT
SUPORTE BRAZOS 
 SUPPORT BRAS

POS Codice	Q.tà	 Descrizione	 Description	 Designation	 Benennung	 Descripción
46 07031800	2 NR	tubo	pipe	tuyau	rohr	tubo
46 07190600	1 NR	copertura supporto telecomando (solo macchine modello jp e ja e x17j)	cover support remote control (only machines model jp and ja and x17j)	couverture support de la telecommande	cover fernbedienungshalter	cubierta soporte de control remoto
47 07190500	1 NR	piegato bloccaggio telecomando (solo macchine modello jp e ja e x17j)	bended locking remote control (only machines model jp and ja and x17j)	bent blocage telecommande	bent einrasten fernbedienung	bent bloqueo de control remoto
48 07190800	1 NR	staffa fissaggio chiusura bloccaggio telecomando (solo macchine modello jp e ja e x17j)	bracket locking remote control (only machines model jp and ja and x17j)	fin de support de blocage telecommande	bracket end einrasten fernbedienung	soporte de fin de bloqueo de control remoto
49 07239800	1 NR	piastra fissaggio cesto (solo macchine modello jp e ja e x17j)	fixing plate basket (only machines model jp and ja and x17j)	plate fixation drum	plate befestigung drum	placa fijación tambor
51 07192700	1 NR	chiusura a volantino con leva piegata (solo macchine modello jp e ja e x17j)	locking wheel with bent lever (only machines model jp and ja and x17j)	fin de support de blocage telecommande	bracket end einrasten fernbedienung	soporte de fin de bloqueo de control remoto

 ACCOPPIAMENTO MOTORE - POMPA

PUMPEN / MOTOR KUPPLUNG 

 ENGINE COUPLING - PUMP



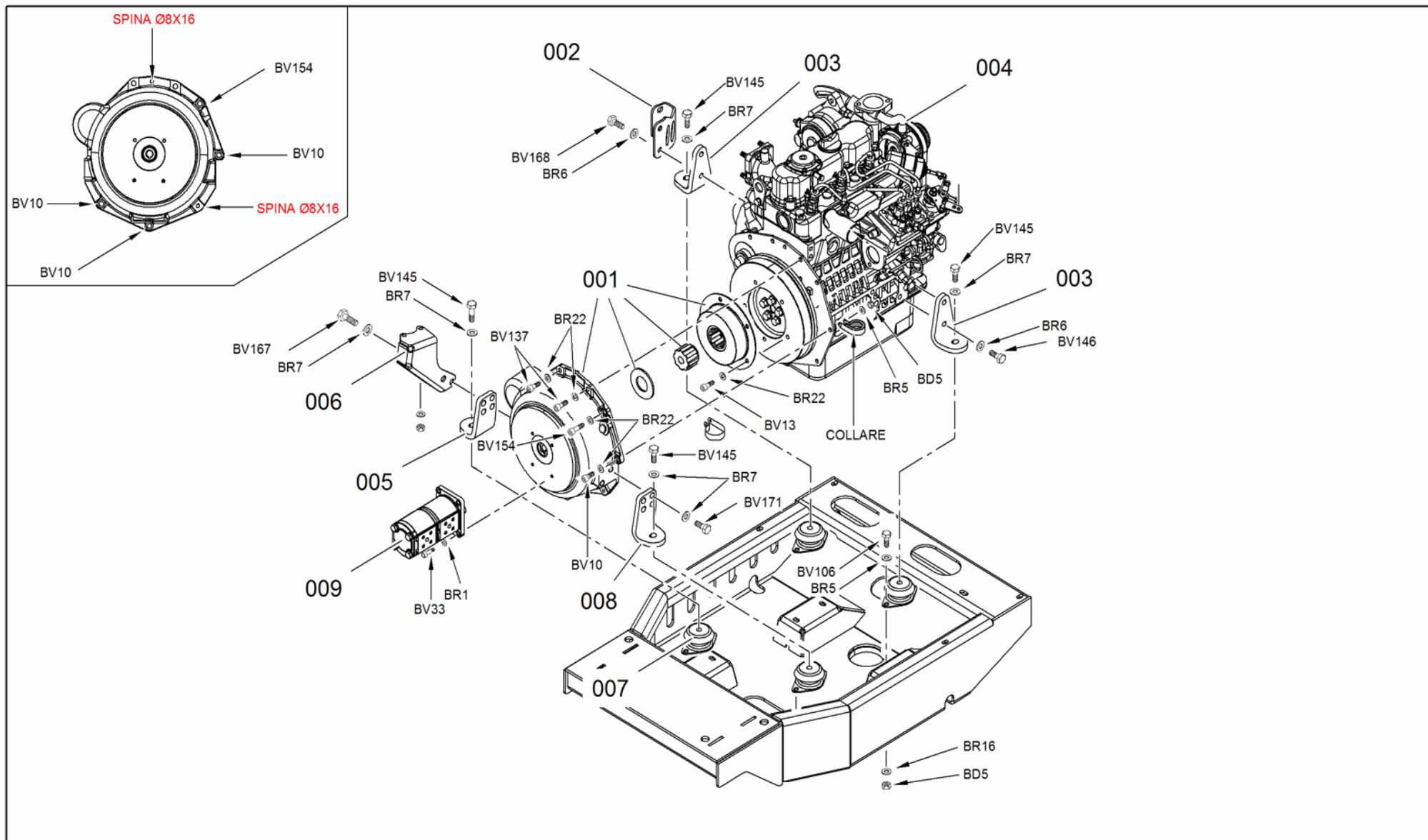

ACOPLAMIENTO MOTOR - BOMBA 

 ACCOUPLEMENT MOTEUR - POMPE





 ACCOPPIAMENTO MOTORE - POMPA
PUMPEN / MOTOR KUPPLUNG 
 ENGINE COUPLING - PUMP
ACOPLAMIENTO MOTOR - BOMBA 
 ACCOUPLEMENT MOTEUR - POMPE

POS Codice	Q.tà	 Descrizione	 Description	 Designation	 Benennung	 Descripción
1 26458100	1 NR	motore diesel 14hp (no carb-epa cert)	diesel engine 14hp (no carb-epa cert)	moteur diesel	dieselmotor	motor diesel
2 06313500	1 NR	supporto	support	support	halterung	soporte
3 06458400	4 NR	antivibrante	anti-vibrating	anti - vibrant	vibrationsdämpfer	antivibrante
4 06313400	1 NR	supporto	support	support	halterung	soporte
5 26458500	1 NR	accoppiamento motore diesel - pompa	diesel engine coupling - pump	accouplement moteur diesel - pompe	pumpen / dieselmotor kupplung	acoplamiento motor diesel- bomba
6 14615200	1 NR	pompa idraulica	hydraulic pump	pompe hydraulique	hydraulikpumpe	bomba hidráulica
7 06543800	1 NR	staffa	bracket	étrier	haltebügel	estribo
8 1651380001	1 NR	relè	relay	relais	relais	relé
9 1651380002	1 NR	relè	relay	relais	relais	relé
10 1651380003	1 NR	scatola elettrica	electric box	boîte électrique	elektrogehäuse	caja eléctrica
11 16855700	1 NR	cablaggio	wiring	câblage	verkabelung	cableado
12 25952600	1 NR	motore benzina	petrol engine	moteur a essence	benzinmotor	motor de gasolina
13 05955100	2 NR	piatto	plate	plateau	platte	placa
14 05535300	4 NR	antivibrante versione benzina	anti-vibrating gasoline version	anti - vibrant	vibrationsdämpfer	antivibrante
15 04310200	1 NR	semigiunto	half coupling	demi-joint	halbverbindung	semi-acoplamiento





 ACCOPPIAMENTO MOTORE - POMPA

PUMPEN / MOTOR KUPPLUNG 

 ENGINE COUPLING - PUMP

ACOPLAMIENTO MOTOR - BOMBA 

 ACCOUPLEMENT MOTEUR - POMPE

POS Codice	Q.tà	 Descrizione	 Description	 Designation	 Benennung	 Descripción
16 04310100	1 NR	inserto in gomma	rubber insert	insert en caoutchouc	gummeinsatz	inserto de goma
17 04615300	1 NR	giunto	coupling	joint	verbindung	acoplamiento
18 04310300	1 NR	lanterna	lantern	lanterne	buchse	linterna
19 06117700	1 NR	staffa	bracket	étrier	haltebügel	estribo
21 05922000	1 NR	deflettore	deflector	défecteur	abweiser	deflector
22 06691400	1 NR	guaina termoresistente	sheath thermorestant	thermofermes gaine	sheath thermostabile	funda termorresistente

 RICAMBI MOTORE DIESEL

MOTORERSATZTEILE DIESEL 

 ENGINE SPARE PARTS DIESEL

REPUESTOS MOTOR DIESEL 



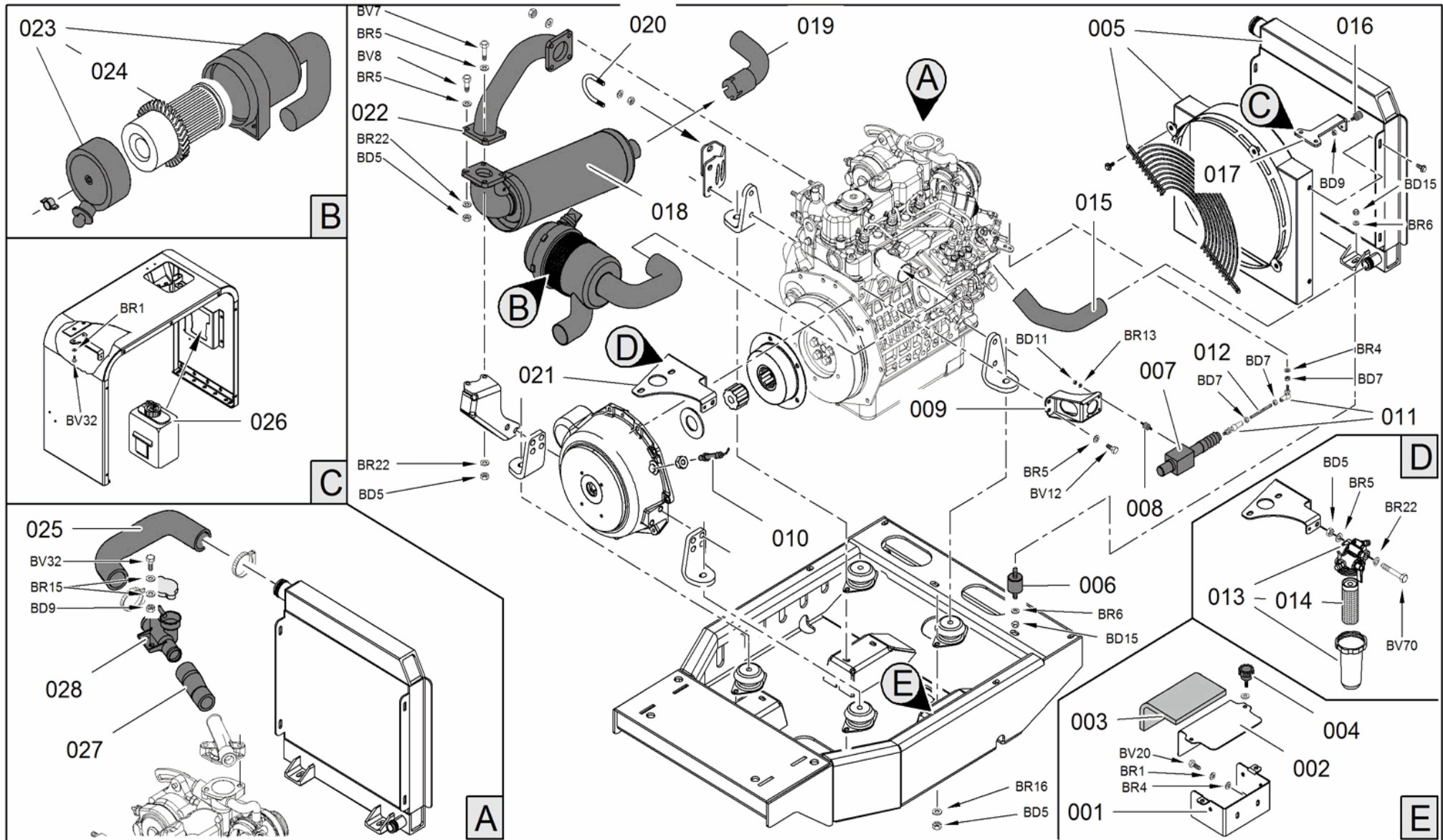

 PIÈCES DÉTACHÉES DU MOTEUR DIESEL







 RICAMBI MOTORE DIESEL

 MOTORERSATZTEILE DIESEL 
 ENGINE SPARE PARTS DIESEL

 REPUESTOS MOTOR DIESEL 
 PIÈCES DÉTACHÉES DU MOTEUR DIESEL

POS Codice	Q.tà	 Descrizione	 Description	 Designation	 Benennung	 Descripción
1 2645810008	1 NR	ventola	fan	ventilateur	lüfterrad	ventilador
2 2645810007	1 NR	termostato	thermostat	thermostat	temperaturregler	termóstato
3 2645810019	1 NR	bulbo temperatura acqua	water temperature bulb	boule température eau	wassertemperaturk ugel	cubeta temperatura agua
4 2645810023	1 NR	pompa acqua	water pump	pompe à eau	wasserpumpe	bomba de agua
5 2645810009	1 NR	guarnizione	gasket	joint	dichtung	guarnición
6 2645810006	1 NR	piastra	plate	platine	platte	placa
7 2645810010	1 NR	guarnizione	gasket	joint	dichtung	guarnición
8 06551400	4 NR	antivibrante	anti-vibrating	anti - vibrant	vibrationsdämpfer	antivibrante
8 2645810016	1 NR	tappo olio	oil plug	bouchon d'huile	öldeckel	oliedop
9 2645810001	1 NR	guarnizione	gasket	joint	dichtung	guarnición
10 2645810020	1 NR	solenoido	solenoid	solenoid	solenoid	solenoido
11 04271000	1 NR	filtro olio	oil filter	filtre à huile	ölfilter	filtro aceite
12 2645810021	1 NR	pompa alimentazione gasolio	gas oil fuel pump	pompe d'alimentation diesel	diesel förderpumpe	bomba dealimentación gasoleo
13 2645810022	1 NR	pompante alimentazione gasolio	gas oil fuel pump	pompe d'alimentation gasoil	kraftstoffversorgung spumpe	bomba de alimentación gasoleo

 RICAMBI MOTORE DIESEL
MOTORERSATZTEILE DIESEL 
 ENGINE SPARE PARTS DIESEL
REPUESTOS MOTOR DIESEL 
 PIÈCES DÉTACHÉES DU MOTEUR DIESEL

POS Codice	Q.tà	 Descrizione	 Description	 Designation	 Benennung	 Descripción
14 2645810012	1 NR	motorino avviamento	starter motor	démarrreur	anlasser	motor de arranque
15 2645810015	1 NR	astina livello olio	oil dipstick	tipe niveau huile	ölstandstab	varilla nivel aceite
16 2645810003	1 NR	pompa iniezione	injection pump	pompe d'injection	einspritzpumpe	einspritzpumpe
17 2645810004	1 NR	guarnizione	gasket	joint	dichtung	guarnición
18 2645810013	1 NR	bulbo pressione olio	bulb	boule	oiltemperaturbol	cubeta
19 2645810005	1 NR	tubo	pipe	tuyau	rohr	tubo
20 04089800	1 NR	cartuccia filtro olio	oil filter cartridge	cartouche filtre à huile	ölfiltereinsatz	filtro de aceite
21 2645810002	1 NR	filtro gasolio	gas oil filter	filtre à gasoil	kraftstofffilter	filtro gasóleo
22 2645810011	1 NR	alternatore	alternator	alternateur	wechselstromgener ator	alternador
23 2645810014	1 NR	regolatore di tensione	voltage regulator	régulateur de tension	spannungsregler	regulador de tensión
24 05978500	1 NR	connettore	connector	connecteur	verbinger	conectador

 MOTORI ELETTRICI E POMPA

E-MOTOR 



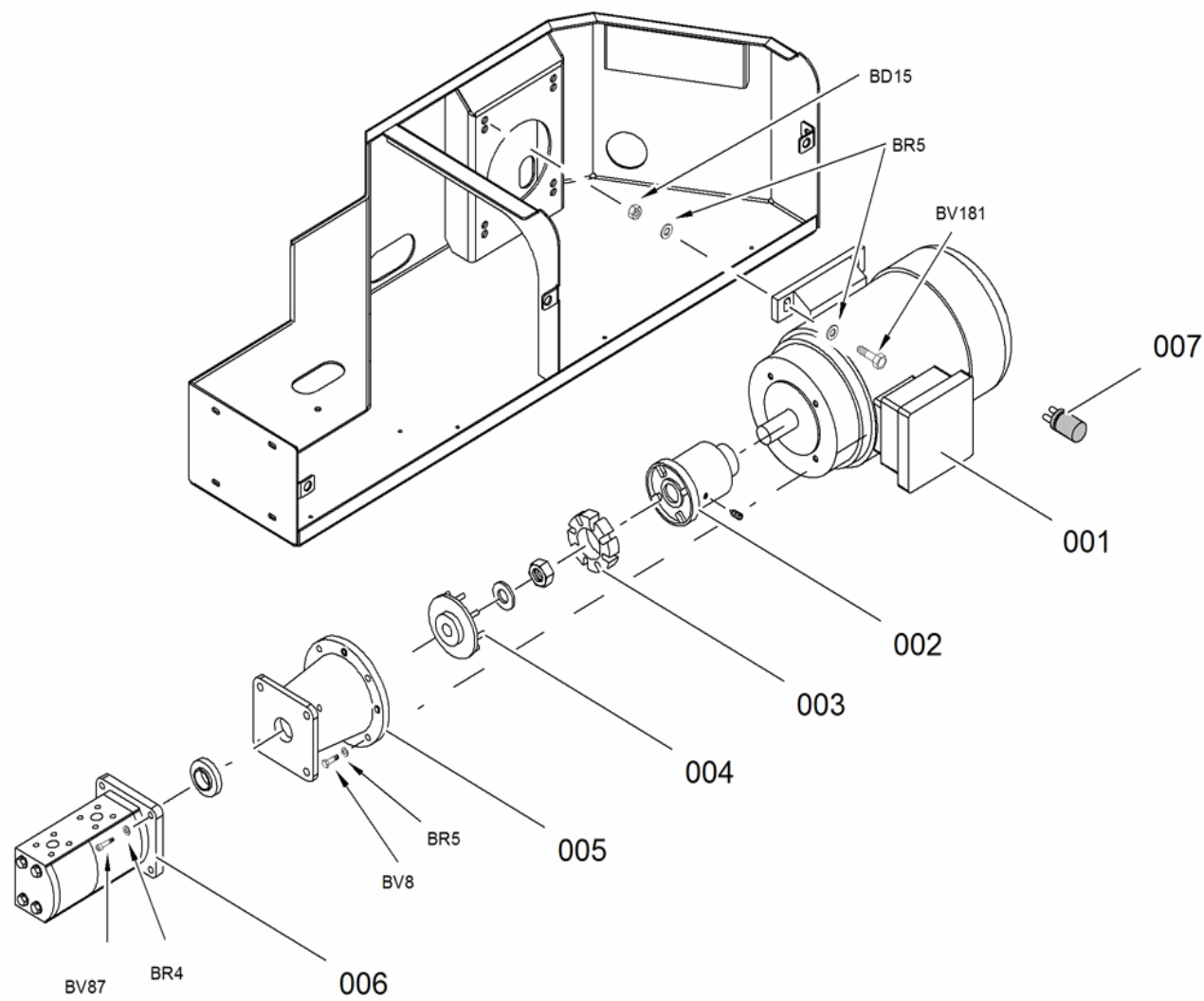

 ELECTRIC MOTOR

MOTOR ELÉCTRICO 





 MOTEUR ÉLECTRIQUE



 MOTORI ELETTRICI E POMPA
E-MOTOR 
 ELECTRIC MOTOR
MOTOR ELÉCTRICO 
 MOTEUR ÉLECTRIQUE

POS	Codice	Q.tà	 Descrizione	 Description	 Designation	 Benennung	 Descripción
1	25510100	1 NR	motore elettrico 230v 50hz	electric motor 230v 50hz	moteur électrique 230v 50hz	e-motor 230v 50hz	motor eléctrico 230v 50hz
1	25576400	1 NR	motore elettrico 110v	electric motor 110v	moteur électrique 110v	e-motor 110v	motor eléctrico 110v
1	26219000	1 NR	motore elettrico 230v 60hz	electric motor 230v 60hz	moteur électrique 230v 60hz	e-motor 230v 60hz	motor eléctrico 230v 60hz
1	26328300	1 NR	motore elettrico 120v 60hz 1.2kw 16a	electric motor 120v 60hz 1.2kw 16a	moteur électrique	e-motor	motor eléctrico
1	26948000	1 NR	notore elettrico 3500w lithium 72v	electric motor 3500w lithium 72v	motoréducteur	getriebemotor	motorreductor
2	05563400	1 NR	semigiunto versione motore elettrico standard	half coupling electric motor standard version	demi-joint	halbverbindung	semi-acoplamiento
2	06997800	1 NR	semigiunto versione litio	half coupling lithium version	demi-joint	halbverbindung	semi-acoplamiento
3	04310100	1 NR	inserto in gomma	rubber insert	insert en caoutchouc	gummieinsatz	inserto de goma
4	04615300	1 NR	giunto	coupling	joint	verbindung	acoplamiento
5	05510200	1 NR	lanterna	lantern	lanterne	buchse	linterna

 MOTORI ELETTRICI E POMPA
E-MOTOR 
 ELECTRIC MOTOR
MOTOR ELÉCTRICO 
 MOTEUR ÉLECTRIQUE

POS	Codice	Q.tà	 Descrizione	 Description	 Designation	 Benennung	 Descripción
6	14615200	1 NR	pompa idraulica	hydraulic pump	pompe hydraulique	hydraulikpumpe	bomba hidráulica
6	25526300	1 NR	pompa idraulica	hydraulic pump	pompe hydraulique	hydraulikpumpe	bomba hidráulica
6	26328100	1 NR	pompa idraulica per motore 120v	hydraulic pump for electric motor 120v	pompe hydraulique	hydraulikpumpe	bomba hidráulica
7	2551010001	1 NR	condensatore 230v mf80 d=55	condenser 230v mf80 d=55	condensateur	kondensator	condensador
7	2557640001	1 NR	condensatore 110v mf200 d=65	capacitor 110v mf200 d=65	condensateur	capacitor	capacitor
7	2557640002	1 NR	condensatore 110v mf500	capacitor 110v mf500	condensateur	capacitor	capacitor
7	2632830001	1 NR	condensatore per motore 120v mf120 d=55	capacitor motor 120v mf120 d = 55	condensateur	kondensator	condensador
7	2632830002	1 NR	condensatore per motore 120v mf160 d=60	capacitor motor 120v mf160 d = 60	condensateur	kondensator	condensador



 IMPIANTO IDRAULICO MANDATA E SCARICO

HYDRAULIKANLAGE VORLÄUFE UND RÜCKLAUF 



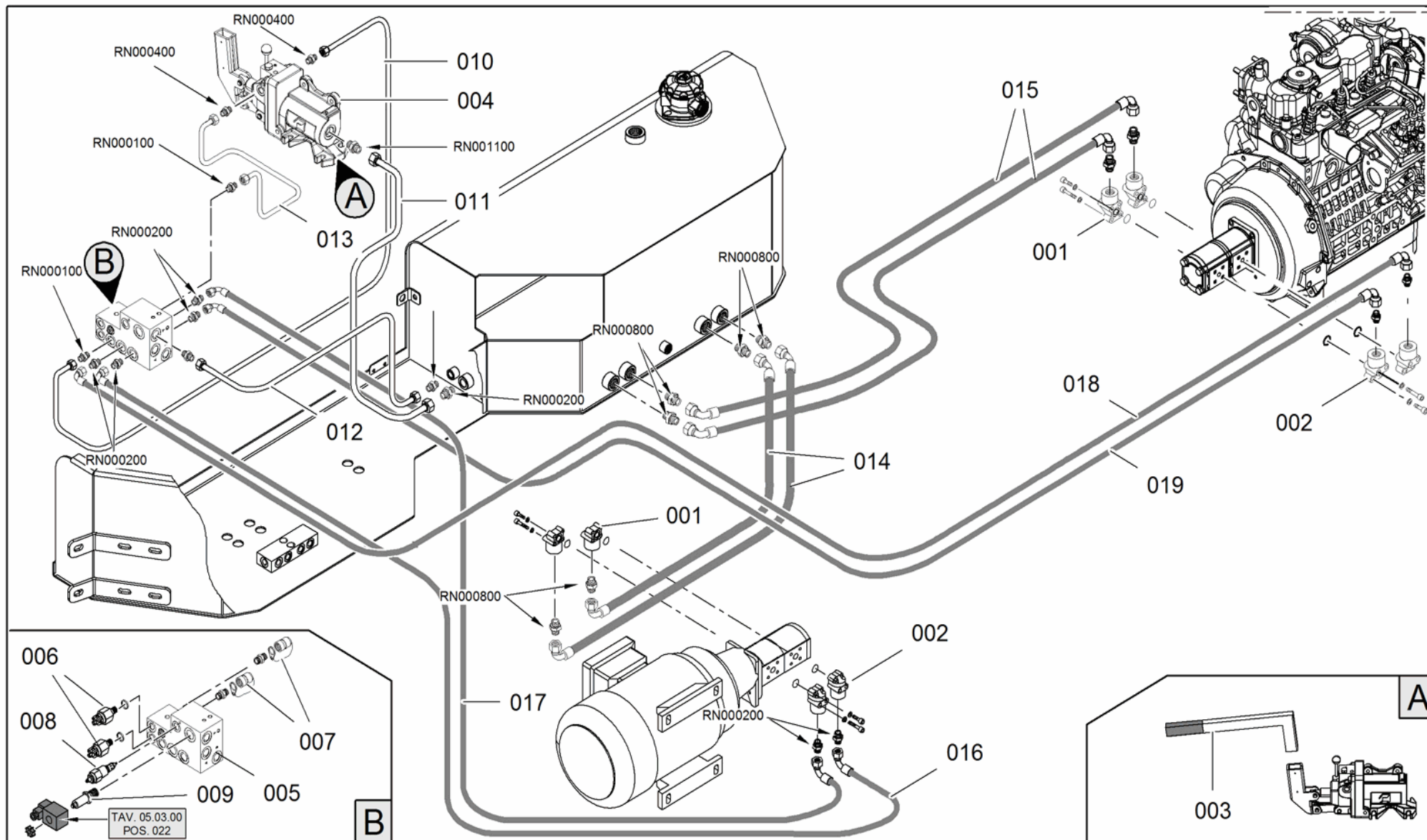

 SUPPLY AND DISCHARGE HYDRAULIC SYSTEM

INSTALCIÓN HIDRÁULICA IMPULSIONES Y DESCARGA 

 SYSTÈME HYDRAULIQUE REFOULEMENT ET DÉCHARGEME



 IMPIANTO IDRAULICO MANDATA E SCARICO
HYDRAULIKANLAGE VORLÄUFE UND RÜCKLAUF 
 SUPPLY AND DISCHARGE HYDRAULIC SYSTEM
INSTALACIÓN HIDRÁULICA IMPULSIONES Y DESCARGA 
 SYSTÈME HYDRAULIQUE REFOULEMENT ET DÉCHARGEME

POS	Codice	Q.tà	 Descrizione	 Description	 Designation	 Benennung	 Descripción
1	06460000	2 NR	tubo flessibile	flexible pipe	tuyau flexible	schlauch	tubo flexible
1	04845400	2 NR	flangia 1/2"g	flange 1/2"g	bride 1/2"g	flansch 1/2"g	brida 1/2"g
2	04048100	2 NR	flangia 3/8" g	flange 3/8" g	bride 3/8" g	flansch 3/8" g	brida 3/8" g
4	26459400	1 NR	pompa a mano	hand pump	pompe manuelle	handpumpe	bomba de mano
5	06467300	1 NR	tubo flessibile	flexible pipe	tuyau flexible	schlauch	tubo flexible
6	06460300	1 NR	tubo flessibile	flexible pipe	tuyau flexible	schlauch	tubo flexible
7	03014400	2 NR	prova pressione 1/4" g	pressure test 1/4" g	preuve pression 1/4" g	druckkontrolle 1/4" g	prueba presión 1/4" g
7	06460600	1 NR	tubo flessibile	flexible pipe	tuyau flexible	schlauch	tubo flexible
8	06460100	1 NR	tubo rigido tubo flessibile	flexible pipe	tuyau flexible	schlauch	tubo flexible
9	06460200	2 NR	tubo flessibile	flexible pipe	tuyau flexible	schlauch	tubo flexible
10	06460400	1 NR	tubo flessibile	flexible pipe	tuyau flexible	schlauch	tubo flexible
11	06460500	1 NR	tubo flessibile	flexible pipe	tuyau flexible	schlauch	tubo flexible
13	06543400	1 NR	tubo rigido	rigid pipe	tuyau rigide	rohr	tubo rígido
14	04707700	1 NR	collettore	manifold	collecteur	kollektor	colector
16	06543300	1 NR	tubo rigido	rigid pipe	tuyau rigide	rohr	tubo rígido
17	06468100	1 NR	tubo rigido	rigid pipe	tuyau rigide	rohr	tubo rígido





 IMPIANTO IDRAULICO MANDATA E SCARICO

HYDRAULIKANLAGE VORLÄUFE UND RÜCKLAUF 

 SUPPLY AND DISCHARGE HYDRAULIC SYSTEM

INSTALACIÓN HIDRÁULICA IMPULSIONES Y DESCARGA 

 SYSTÈME HYDRAULIQUE REFOULEMENT ET DÉCHARGEME

POS Codice	Q.tà	 Descrizione	 Description	 Designation	 Benennung	 Descripcìon
18 06467800	1 NR	tubo rigido	rigid pipe	tuyau rigide	rohr	tubo rìgido
19 16478200	1 NR	valvola idraulica	hydraulic valve	valve hydraulique	valve hydraulique	válvula hidráulica
20 06467700	1 NR	tubo rigido	rigid pipe	tuyau rigide	rohr	tubo rìgido
21 16517700	1 NR	leva	lever	levier	hebel	palanca
22 26964400	2 NR	pressostato	pressure switch	pression	druckwächter	presión

 IMPIANTO IDRAULICO MANDATA E SCARICO

HYDRAULIKANLAGE VORLÄUFE UND RÜCKLAUF 



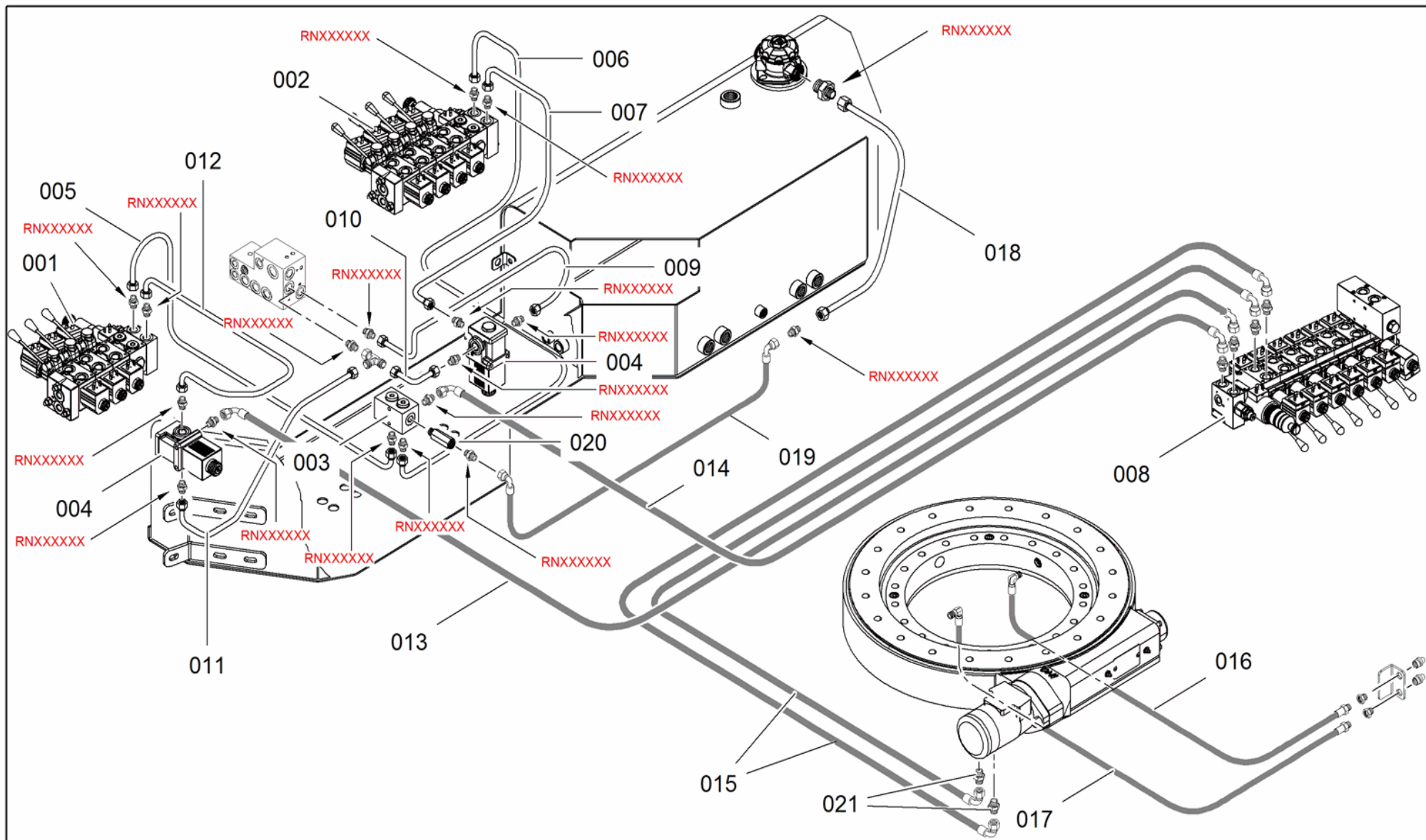

 SUPPLY AND DISCHARGE HYDRAULIC SYSTEM

INSTALACIÓN HIDRÁULICA IMPULSIONES Y DESCARGA 





 SYSTÈME HYDRAULIQUE REFOULEMENT ET DÉCHARGEME



 IMPIANTO IDRAULICO MANDATA E SCARICO
HYDRAULIKANLAGE VORLÄUFE UND RÜCKLAUF 
 SUPPLY AND DISCHARGE HYDRAULIC SYSTEM
INSTALACIÓN HIDRÁULICA IMPULSIONES Y DESCARGA 
 SYSTÈME HYDRAULIQUE REFOULEMENT ET DÉCHARGEME

POS Codice	Q.tà	 Descrizione	 Description	 Designation	 Benennung	 Descripción
1 26459000	1 NR	distributore idraulico 4 elementi per traslazione	hydraulic distributor 4 sections for translation	distributeur hydraulique	hydraulisches regelsteuergerät	distribuidor hidráulico
1 27299100	1 NR	distributore lc stabilizzatori-traino 4 elementi con leve emergenza a pulsante	hydraulic distributor stabilizers-tracks 4 parts with levers emergency button	distributeur hydraulique	hydraulisches regelsteuergerät	distribuidor hidráulico
2 06464700	1 NR	tubo flessibile	flexible pipe	tuyau flexible	schlauch	tubo flexible
3 05497500	1 NR	blocchetto tubi	hoses block	bloc tuyaux	rohrblock	bloque tubos
3 06464600	1 NR	tubo flessibile	flexible pipe	tuyau flexible	schlauch	tubo flexible
4 26458900	1 NR	distributore idraulico 3 elementi per traslazione	hydraulic distributor 3 elements to translation	distributeur hydraulique	hydr. regelsteuergerät	distribuidor hidráulico
4 27299000	1 NR	distributore lc stabilizzatori-traino 3 elementi con leve emergenza a pulsante	hydraulic distributor stabilizers-tracks 3 parts with levers emergency button	distributeur hydraulique	hydr. regelsteuergerät	distribuidor hidráulico
5 06478000	1 NR	tubo flessibile	flexible pipe	tuyau flexible	schlauch	tubo flexible
6 06460800	1 NR	tubo flessibile	flexible pipe	tuyau flexible	schlauch	tubo flexible
7 25952500	1 NR	distributore idraulico	hydraulic distributor	distributeur hydraulique	hydr. regelsteuergerät	distribuidor hidráulico





 IMPIANTO IDRAULICO MANDATA E SCARICO
HYDRAULIKANLAGE VORLÄUFE UND RÜCKLAUF 
 SUPPLY AND DISCHARGE HYDRAULIC SYSTEM
INSTALACIÓN HIDRÁULICA IMPULSIONES Y DESCARGA 
 SYSTÈME HYDRAULIQUE REFOULEMENT ET DÉCHARGEME

POS Codice	Q.tà	 Descrizione	 Description	 Designation	 Benennung	 Descripción
8 06465400	1 NR	tubo flessibile	flexible pipe	tuyau flexible	schlauch	tubo flexible
9 06465500	1 NR	tubo flessibile	flexible pipe	tuyau flexible	schlauch	tubo flexible
10 05912600	1 NR	colonna femmina 1/4"- femmina 1/4" unidirezionale	female thread 1/4 "- 1/4 female" unidirectional	goujon	schraubbolzen	prolongación
11 06468600	1 NR	tubo flessibile	flexible pipe	tuyau flexible	schlauch	tubo flexible
12 06465600	2 NR	tubo flessibile	flexible pipe	tuyau flexible	schlauch	tubo flexible
13 05725900	2 NR	raccordo speciale per motore di rotazione (gl e versione lithium)	special fitting for motor rotation (gl version and lithium)	raccord	anschluss	conexión
14 06460900	2 NR	tubo flessibile	flexible pipe	tuyau flexible	schlauch	tubo flexible
15 26062200	1 NR	accumulatore	accumulator	accumulteur	akkumulator	acumulador
16 06903200	2 NR	raccordo ø=0.7mm	fitting ø=0.7mm	raccord ø=0.7mm	anschluss ø=0.7mm	conexión ø=0.7mm
16 07022000	2 NR	nipples forato 3/8" - 10l ø=0,8mm	pierced nipples 3/8 "- 10l ø = 0.8 mm	nipples perforé 3/8 "- 10l ø = 0,8 mm	brustwarzen mit bohrung 3/8 "- 10l ø = 0,8 mm	pezones con el agujero de 3/8 "- 10l ø = 0,8 mm
17 06551900	1 NR	tubo flessibile	flexible pipe	tuyau flexible	schlauch	tubo flexible

 IMPIANTO IDRAULICO MANDATA E SCARICO

 HYDRAULIKANLAGE VORLÄUFE UND RÜCKLAUF 
 SUPPLY AND DISCHARGE HYDRAULIC SYSTEM

 INSTALACIÓN HIDRÁULICA IMPULSIONES Y DESCARGA 
 SYSTÈME HYDRAULIQUE REFOULEMENT ET DÉCHARGEME

POS Codice	Q.tà	 Descrizione	 Description	 Designation	 Benennung	 Descripción
18 26278000	1 NR	distributore idraulico	hydraulic distributor	distributeur hydraulique	hydr. regelsteuergerät	distribuidor hidráulico
18 27323600	1 NR	distributore idraulico proporzionale parte aerea con pulsante emergenza	distributor hydraulic proportional aerial part with emergency button	distributeur hydraulique	hydr. regelsteuergerät	distribuidor hidráulico
19 05977600	1 NR	vite di regolazione	adjustment screw	souape proportionelle	verstellungsschraube	volante de control
20 06467500	1 NR	tubo rigido	rigid pipe	tuyau rigide	rohr	tubo rígido
21 06467600	1 NR	tubo rigido	rigid pipe	tuyau rigide	rohr	tubo rígido
22 25732900	1 NR	deviatore idraulico	hydraulic diverter	déviateur	wechselschalter	desviador
23 25908400	1 NR	dispositivo di comando manuale idraulico	hand control hydraulic	commande hydraulique	hydraulischer antrieb	comando hidráulico
24 06467900	1 NR	tubo rigido	rigid pipe	tuyau rigide	rohr	tubo rígido
25 1647820001	1 NR	valvola idraulica	hydraulic valve	valve hydraulique	valve hydraulique	válvula hidráulica
26 1647820003	1 NR	elettrovalvola	solenoid valve	électrovanne	magnetventil	electroválvula
28 16543900	1 NR	supporto	support	support	halterung	soporte
29 06786700	1 NR	raccordo	fitting	raccord	anschluss	conexión

 **DISTRIBUTORI IDRAULICI**

**HYDRAULISCHE REGELSTEUERGERÄTE** 

 **HYDRAULIC DISTRIBUTORS**



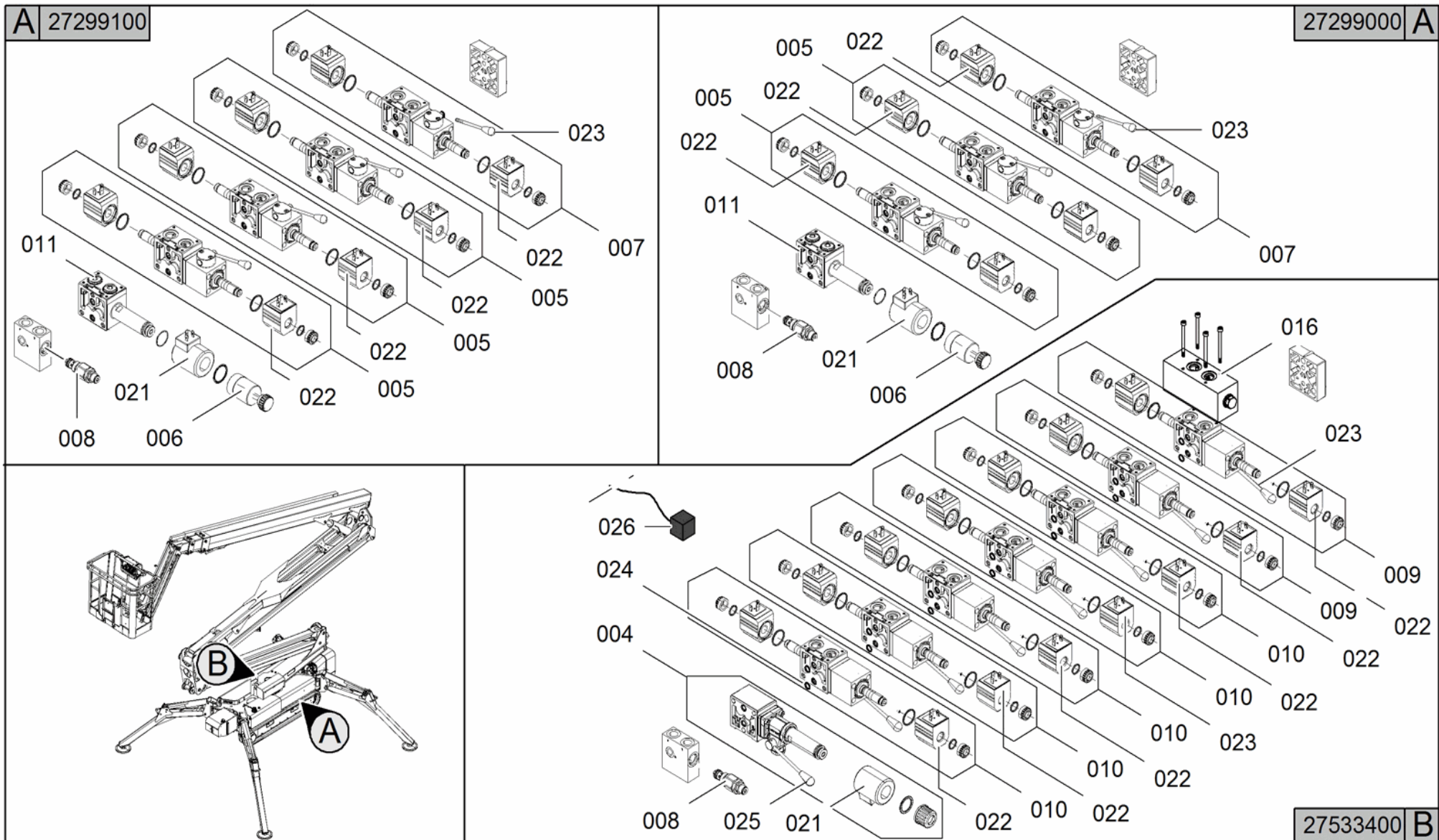

**DISTRIBUIDORES HIDRÁULICOS** 

 **DISTRIBUTEURS HYDRAULIQUES**















 DISTRIBUTORI IDRAULICI
HYDRAULISCHE REGELSTEUERGERÄTE 
 HYDRAULIC DISTRIBUTORS
DISTRIBUIDORES HIDRÁULICOS 
 DISTRIBUTEURS HYDRAULIQUES

POS	Codice	Q.tà	 Descrizione	 Description	 Designation	 Benennung	 Descripción
1	2627800002	1	NR sezione distributore ab chiuso rotazione aerea completo di leva e bobina	section distributor ab closed complete of the lever and coil	section distributeur	regelsteuergerätab schn.	sección distribuidor
2	07325200	1	NR valvola proporzionale (cartuccia) parte aerea piattaforma con ritorno a molla completa di pulsante	proportional valve aerial parts with spring return complete button	commande manuel d'urgence	manuelles antrieb für notstand	mando manual de emergencia
2	2627800003	1	NR valvola proporzionale (cartuccia) parte aerea	proportional valve (cartridge) aerial part	électrovanne	magnetventil	electroválvula
3	06037900	1	NR bobina per valvola proporzionale parte aerea	coil proportional valve for aerial part	bobine	spule	bobina
4	2606210003	1	NR corpo	body	corps	gehäuse	cuerpo
6	07324900	1	NR comando manuale emergenza con ritorno a molla	emergency maual control with spring return	commande manuel d'urgence	manuelles antrieb für notstand	mando manual de emergencia
6	2585420001	1	NR comando manuale emergenza	emergency maual control	commande manuel d'urgence	manuelles antrieb für notstand	mando manual de emergencia

 DISTRIBUTORI IDRAULICI
HYDRAULISCHE REGELSTEUERGERÄTE 
 HYDRAULIC DISTRIBUTORS
DISTRIBUIDORES HIDRÁULICOS 
 DISTRIBUTEURS HYDRAULIQUES

POS Codice	Q.tà	 Descrizione	 Description	 Designation	 Benennung	 Descripcìon
7 2585560009	12 NR	pulsante	button	bouton	druckknopf	botón
7 2585560009	6 NR	pulsante	button	bouton	druckknopf	botón
7 2585560009	8 NR	pulsante	button	bouton	druckknopf	botón
8 2645900002	1 NR	cartuccia valvola di massima pressione	cartridge pressure relief valve	cartouche huile hydr.	hydrauliköleinsatz	cartucho aceite hidr.
9 2585560003	1 NR	sezione distributore	valve block section	section distributeur	regelsteuergerätab schnitt	sección distribuidor
10 2585560002	1 NR	sezione distributore	valve block section	section distributeur	regelsteuergerätab schnitt	sección distribuidor
11 2645900007	1 NR	valvola proporzionale traini con bobina e senza comando manuale	proportional valve for track with coil and without manual override	section distributeur	regelsteuergerätab schn.	sección distribuidor
11 2729900001	1 NR	valvola proporzionale traini con bobina e senza comando manuale a molla	proportional valve for track with coil and without manual spring	valve hydraulique	hydraulikventil	vàlvula hidràulica





 DISTRIBUTORI IDRAULICI
HYDRAULISCHE REGELSTEUERGERÄTE 
 HYDRAULIC DISTRIBUTORS
DISTRIBUIDORES HIDRÁULICOS 
 DISTRIBUTEURS HYDRAULIQUES



POS Codice	Q.tà	 Descrizione	 Description	 Designation	 Benennung	 Descripción
12 2645900005	2 NR	sezione distributore ab chiuso con leva (lato a) e bobina	section distributor ab closed with lever (side a) and coil	section distributeur	regelsteuergerätab schn.	sección distribuidor
12 2645900005	1 NR	sezione distributore ab chiuso con leva (lato a) e bobina	section distributor ab closed with lever (side a) and coil	section distributeur	regelsteuergerätab schn.	sección distribuidor
12 2645900005	3 NR	sezione distributore ab chiuso con leva (lato a) e bobina	section distributor ab closed with lever (side a) and coil	section distributeur	regelsteuergerätab schn.	sección distribuidor
13 2645900006	1 NR	sezione distributore abt con leva (lato a) e bobina	section distributor abt with lever (side a) and coil	section distributeur	regelsteuergerätab schn.	sección distribuidor
16 2585560004	1 NR	blocco valvola bilanciamento bracci su distributori parte aerea	balancing valve block booms of distributors aerial part	bloc soupape	ventilsperre	bloque válvula
21 06037100	1 NR	bobina per valvola proporzionale parte carro	coil proportional valve for undercarriage	bobine	spule	bobina



 DISTRIBUTORI IDRAULICI

 HYDRAULISCHE REGELSTEUERGERÄTE 
 HYDRAULIC DISTRIBUTORS

 DISTRIBUIDORES HIDRÁULICOS 
 DISTRIBUTEURS HYDRAULIQUES

POS Codice	Q.tà	 Descrizione	 Description	 Designation	 Benennung	 Descripció
22 05913800	1 NR	bobina per on-off	coil for on-off	bobine	spule	bobina
22 05913800	2 NR	bobina per on-off	coil for on-off	bobine	spule	bobina
22 05913800	12 NR	bobina per on-off	coil for on-off	bobine	spule	bobina
22 05913800	8 NR	bobina per on-off	coil for on-off	bobine	spule	bobina
22 05913800	6 NR	bobina per on-off	coil for on-off	bobine	spule	bobina
23 07300200	1 NR	leva distributore	lever hydraulic distributor	levier	hebel	palanca
24 2585560005	1 NR	o-ring	o-ring	o-ring	o-ring	o-ring

 IMPIANTO IDRAULICO TRAZIONE  
 HYDRAULIC SYSTEM FOR TRACTION  
 SYSTÈME HYDRAULIQUE DE TRACTION

HYDRAULIKANLAGE ANTRIEB   
INSTALACIÓN HIDRÁULICA TRACCIÓN 

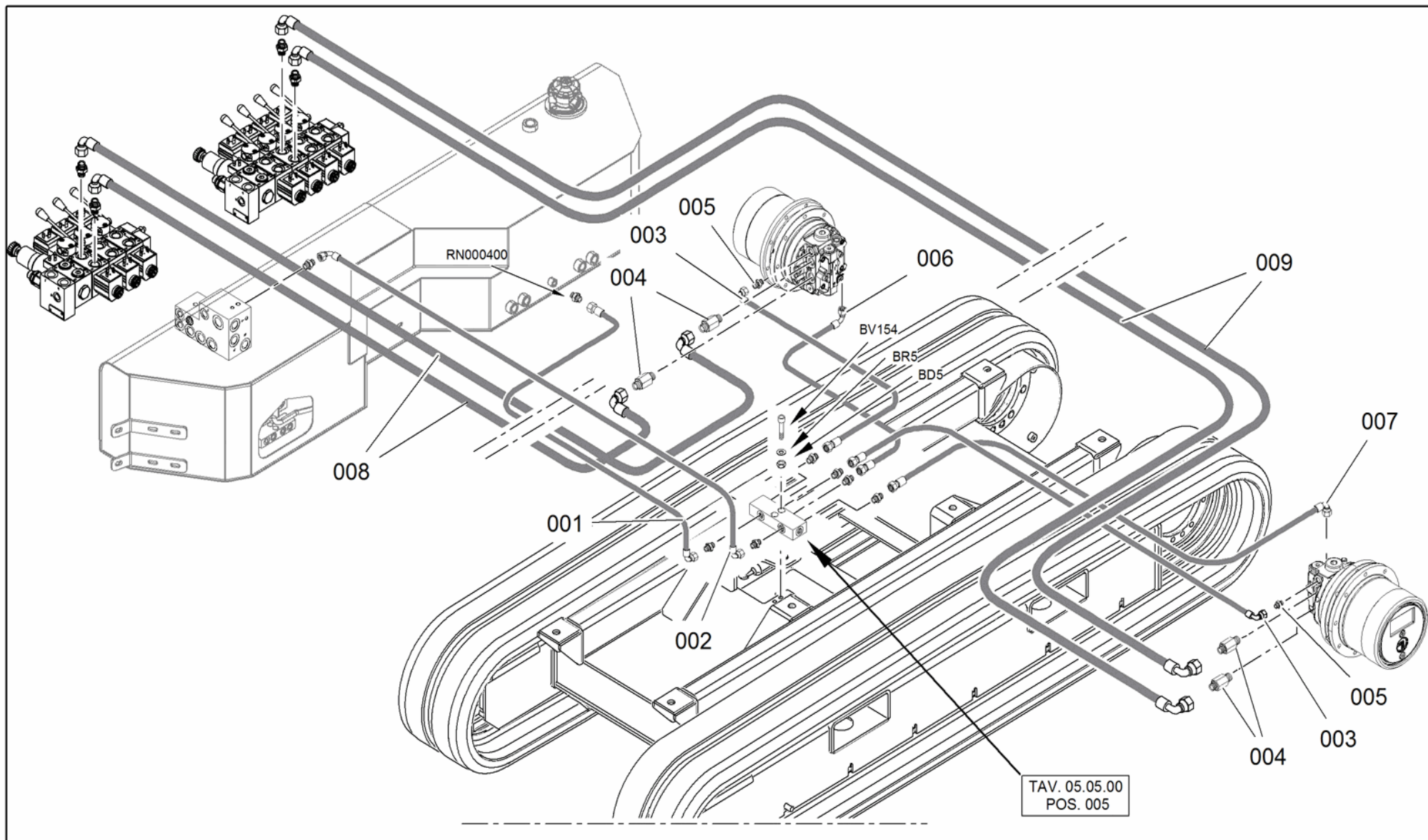





 IMPIANTO IDRAULICO TRAZIONE

HYDRAULIKANLAGE ANTRIEB 

 HYDRAULIC SYSTEM FOR TRACTION

INSTALACIÓN HIDRÁULICA TRACCIÓN 

 SYSTÈME HYDRAULIQUE DE TRACTION

POS Codice	Q.tà	 Descrizione	 Description	 Designation	 Benennung	 Descripción
1 06460700	4 NR	tubo flessibile	flexible pipe	tuyau flexible	schlauch	tubo flexible
3 06464500	1 NR	tubo flessibile	flexible pipe	tuyau flexible	schlauch	tubo flexible
4 05094100	4 NR	raccordo	fitting	raccord	anschluss	conexión
4 06465200	1 NR	tubo flessibile	flexible pipe	tuyau flexible	schlauch	tubo flexible
5 05582000	2 NR	raccordo	fitting	raccord	anschluss	conexión
6 06462000	2 NR	tubo flessibile	flexible pipe	tuyau flexible	schlauch	tubo flexible
7 03149500	1 NR	raccordo a colonna 3/8" h=20	extension 3/8" h=20	montage de la colonne	montage des column	montaje de la columna

 IMPIANTO IDRAULICO ALLARGAMENTO CARRO

HYDRAULIKANLAGE VERBREITERUNG WAGEN 

 HYDRAULIC SYSTEM UNDERCARRIAGE EXPANSION

INSTALACIÓN HIDRAULICA ENSANCHAMIENTO CARRO 

 SYSTÈME HYDRAULIQUE EXTENSION DU CHARIOT

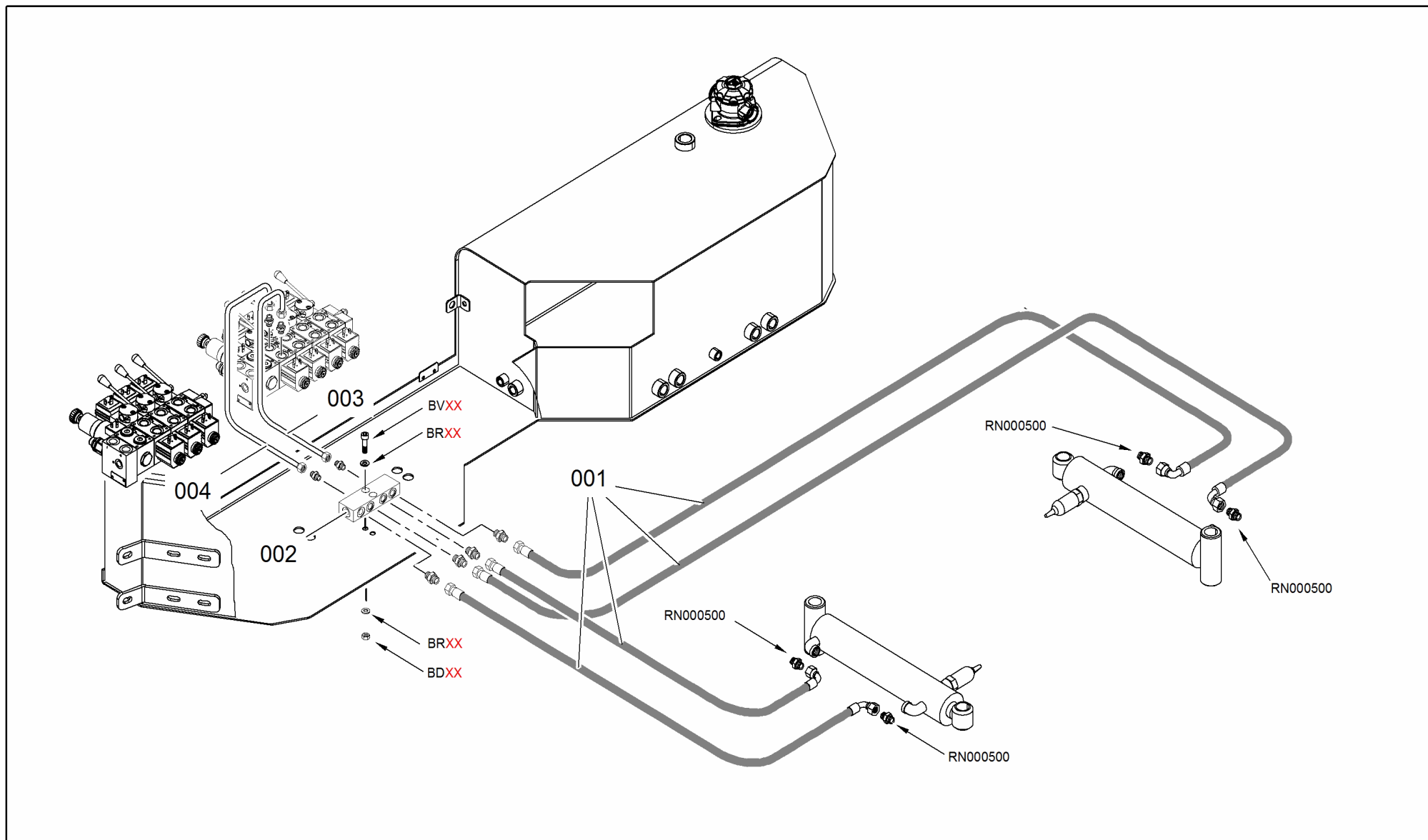





 IMPIANTO IDRAULICO ALLARGAMENTO CARRO

HYDRAULIKANLAGE VERBREITERUNG WAGEN 

 HYDRAULIC SYSTEM UNDERCARRIAGE EXPANSION

INSTALACIÓN HIDRAULICA ENSANCHAMIENTO CARRO 

 SYSTÈME HYDRAULIQUE EXTENSION DU CHARIOT

POS Codice	Q.tà	 Descrizione	 Description	 Designation	 Benennung	 Descripción
1 06461800	1 NR	tubo flessibile	flexible pipe	tuyau flexible	schlauch	tubo flexible
2 06461900	1 NR	tubo flessibile	flexible pipe	tuyau flexible	schlauch	tubo flexible



 IMPIANTO IDRAULICO CILINDRI STABILIZZATORI

ABSTÜTZUNGSZYLINDER ABSTÜTZUNGSHYDRAULIKZYLINDER 

 STABILIZERS CYLINDERS HYDRAULIC SYSTEM

INSTALACIÓN HIDRAULICA CILINDROS ESTABILIZADORS 

 INSTALLATION HYDRAULIQUE CYLINDRES STABILISATERS

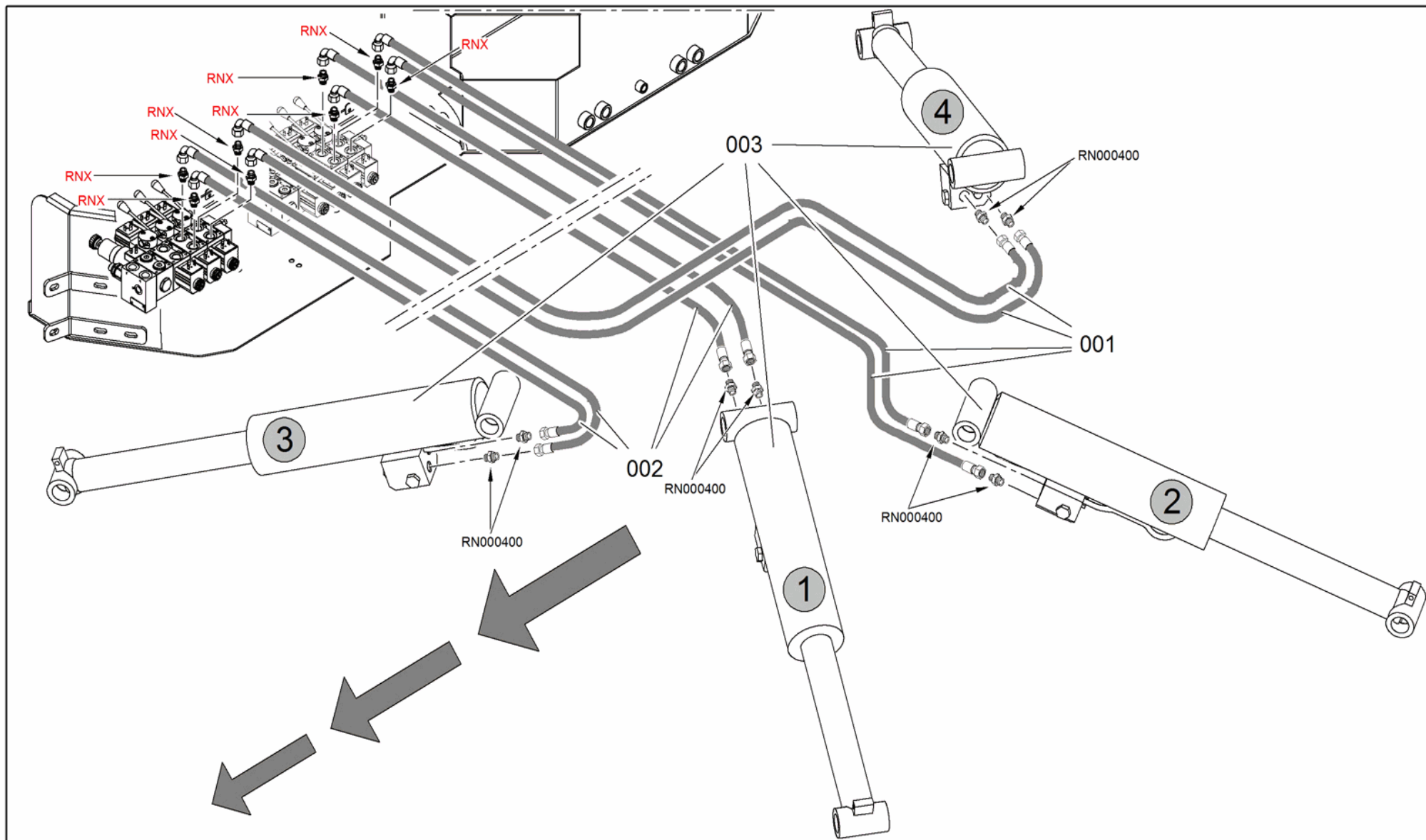







 IMPIANTO IDRAULICO CILINDRI STABILIZZATORI

ABSTÜTZUNGZYLINDER ABSTÜTZUNGSHYDRAULIKZYLINDER 

 STABILIZERS CYLINDERS HYDRAULIC SYSTEM

INSTALACIÓN HIDRAULICA CILINDROS ESTABILIZADORS 

 INSTALLATION HYDRAULIQUE CYLINDRES STABILISATERS

POS Codice	Q.tà	 Descrizione	 Description	 Designation	 Benennung	 Descripcìon
1 06464800	2 NR	tubo flessibile	flexible pipe	tuyau flexible	schlauch	tubo flexible
2 06464900	2 NR	tubo flessibile	flexible pipe	tuyau flexible	schlauch	tubo flexible
3 06465300	4 NR	tubo flessibile	flexible pipe	tuyau flexible	schlauch	tubo flexible
4 26298000	4 NR	cilindro	cylinder	vérin	zylinder	cilindro

 IMPIANTO IDRAULICO 1 - 2 BRACCIO

HYDRAULIKANLAGE 1-2 ARM 

 1-2 ARMS HYDRAULIC SYSTEM

INSTALACIÓN HIDRÁULICA 1-2 BRAZOS 

 SYSTÈME HYDRAULIQUE 1-2 BRAS

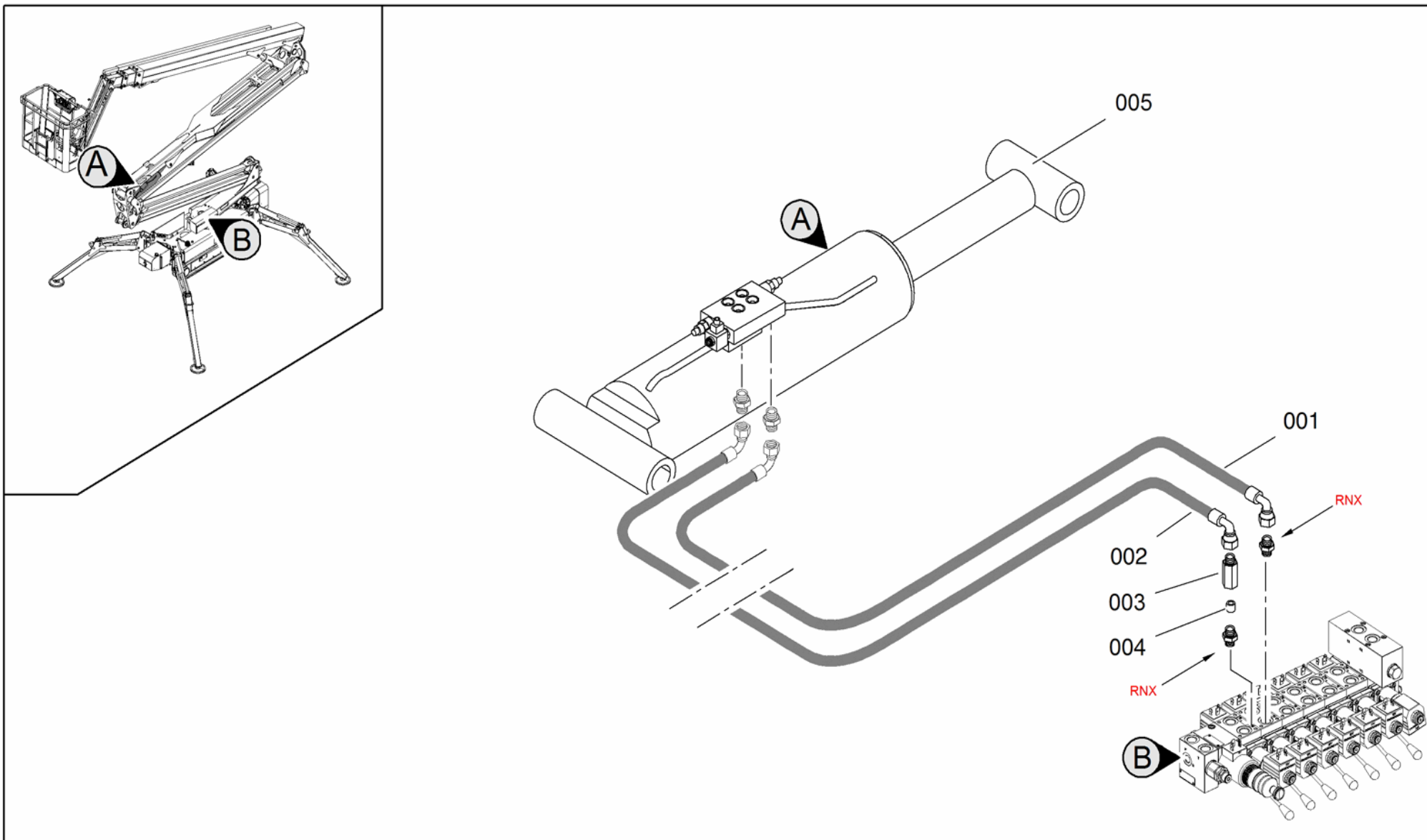





 IMPIANTO IDRAULICO 1 - 2 BRACCIO

HYDRAULIKANLAGE 1-2 ARM 

 1-2 ARMS HYDRAULIC SYSTEM

INSTALACIÓN HIDRÁULICA 1-2 BRAZOS 

 SYSTÈME HYDRAULIQUE 1-2 BRAS

POS Codice	Q.tà	 Descrizione	 Description	 Designation	 Benennung	 Descripción
1 06465800	2 NR	tubo flessibile	flexible pipe	tuyau flexible	schlauch	tubo flexible
2 26903300	1 NR	cilindro 1° e 2° braccio	first and second arm cylinder	cylindre 1ier et 2ème bras	zylinder 1. u. 2. arm	cilindro primero y segundo brazo

 IMPIANTO IDRAULICO 3 BRACCIO

HYDRAULIKANLAGE 3 ARM 

 3 ARM HYDRAULIC SYSTEM

INSTALCIÓN HIDRÁULICA 3 BRAZO 

 SYSTÈME HYDRAULIQUE 3 BRAS

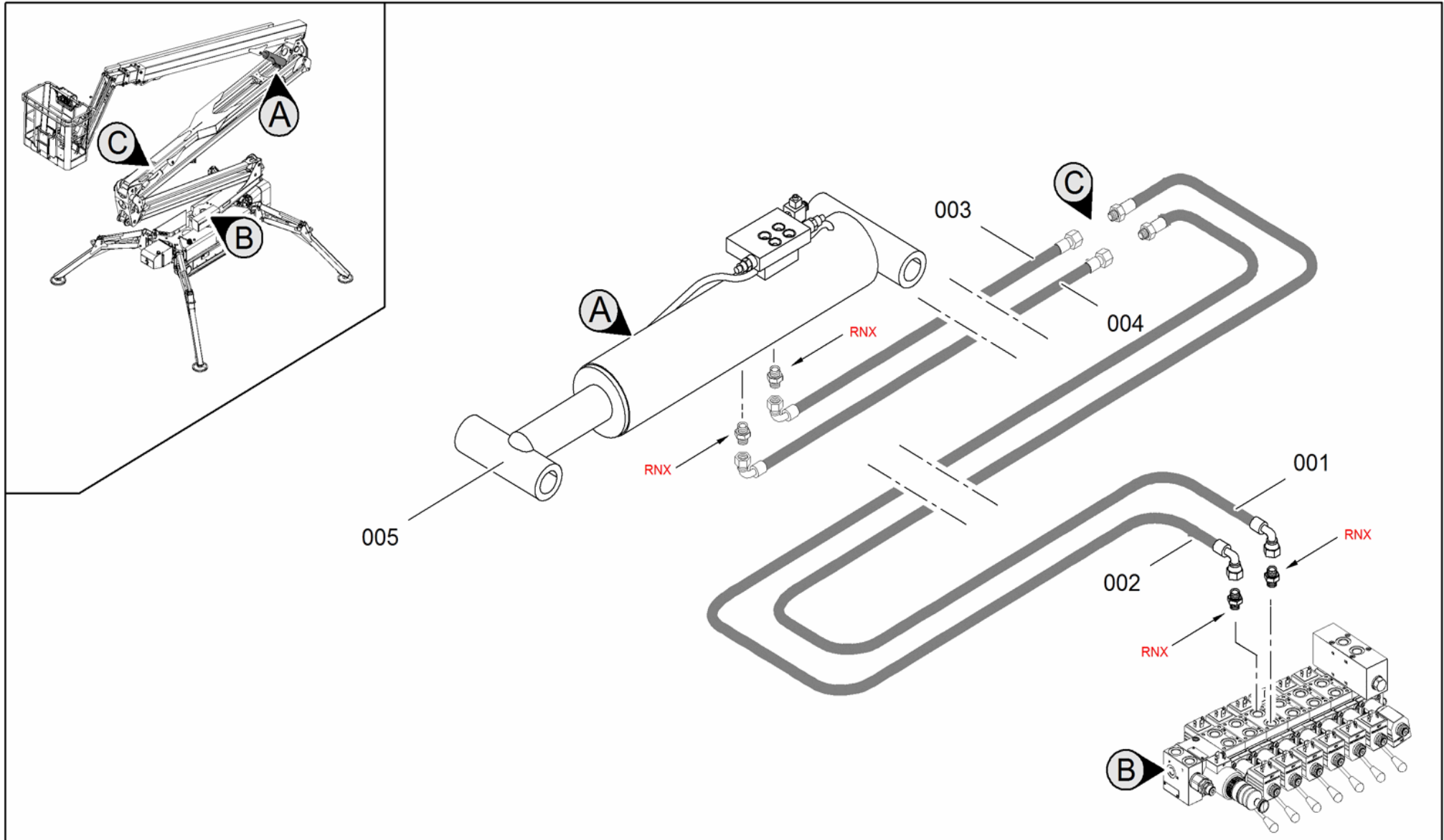





 IMPIANTO IDRAULICO 3 BRACCIO

HYDRAULIKANLAGE 3 ARM 

 3 ARM HYDRAULIC SYSTEM

INSTALACIÓN HIDRÁULICA 3 BRAZO 

 SYSTÈME HYDRAULIQUE 3 BRAS

POS Codice	Q.tà	 Descrizione	 Description	 Designation	 Benennung	 Descripción
1 06465900	2 NR	tubo flessibile	flexible pipe	tuyau flexible	schlauch	tubo flexible
2 26903500	1 NR	cilindro 3° braccio	third arm cylinder	cylindre 3èmebras	zylinder 3. arm	cilindro tercero brazo

 IMPIANTO IDRAULICO SFILO

 TELESCOPIC HYDRAULIC SYSTEM

 TELESCOPIQUE HIDRAULIQUE

TELESKOPHYDRAULIK 

INSTALACIÓN EXTENSIÓN HIDRÁULICA 

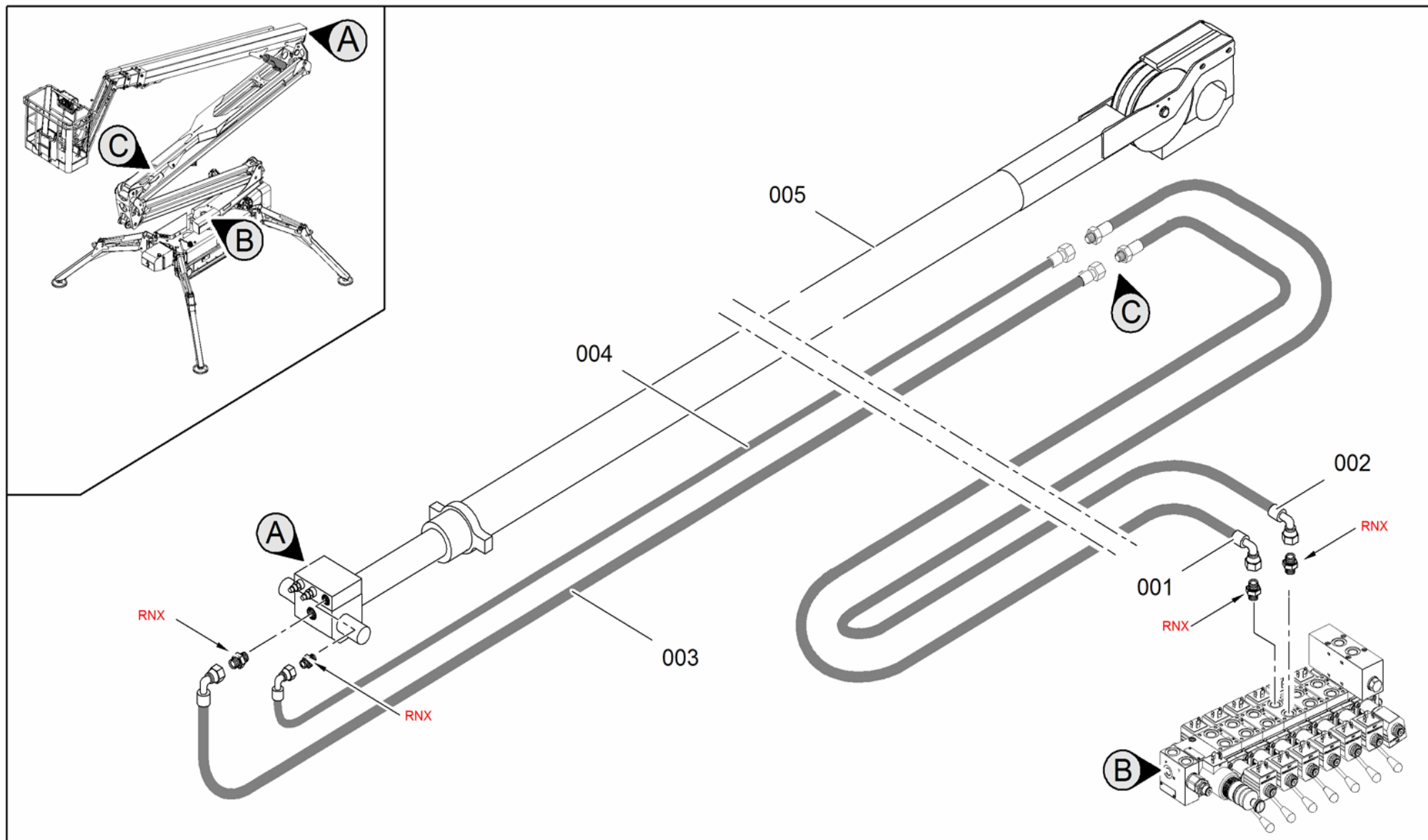







 IMPIANTO IDRAULICO SFILO

TELESKOPHYDRAULIK 

 TELESCOPIC HYDRAULIC SYSTEM

INSTALACIÓN EXTENSIÓN HIDRÁULICA 

 TELESCOPIQUE HIDRAULIQUE

POS Codice	Q.tà	 Descrizione	 Description	 Designation	 Benennung	 Descripcìon
1 06903600	2 NR	tubo flessibile	flexible pipe	tuyau flexible	schlauch	tubo flexible
2 26874000	1 NR	cilindro sfilo	extension cylinder	cylindre sect.télescop.	teleskopzylinder	cil. brazo telescóp.



 IMPIANTO JIB

ZYLINDER JIB ARM 



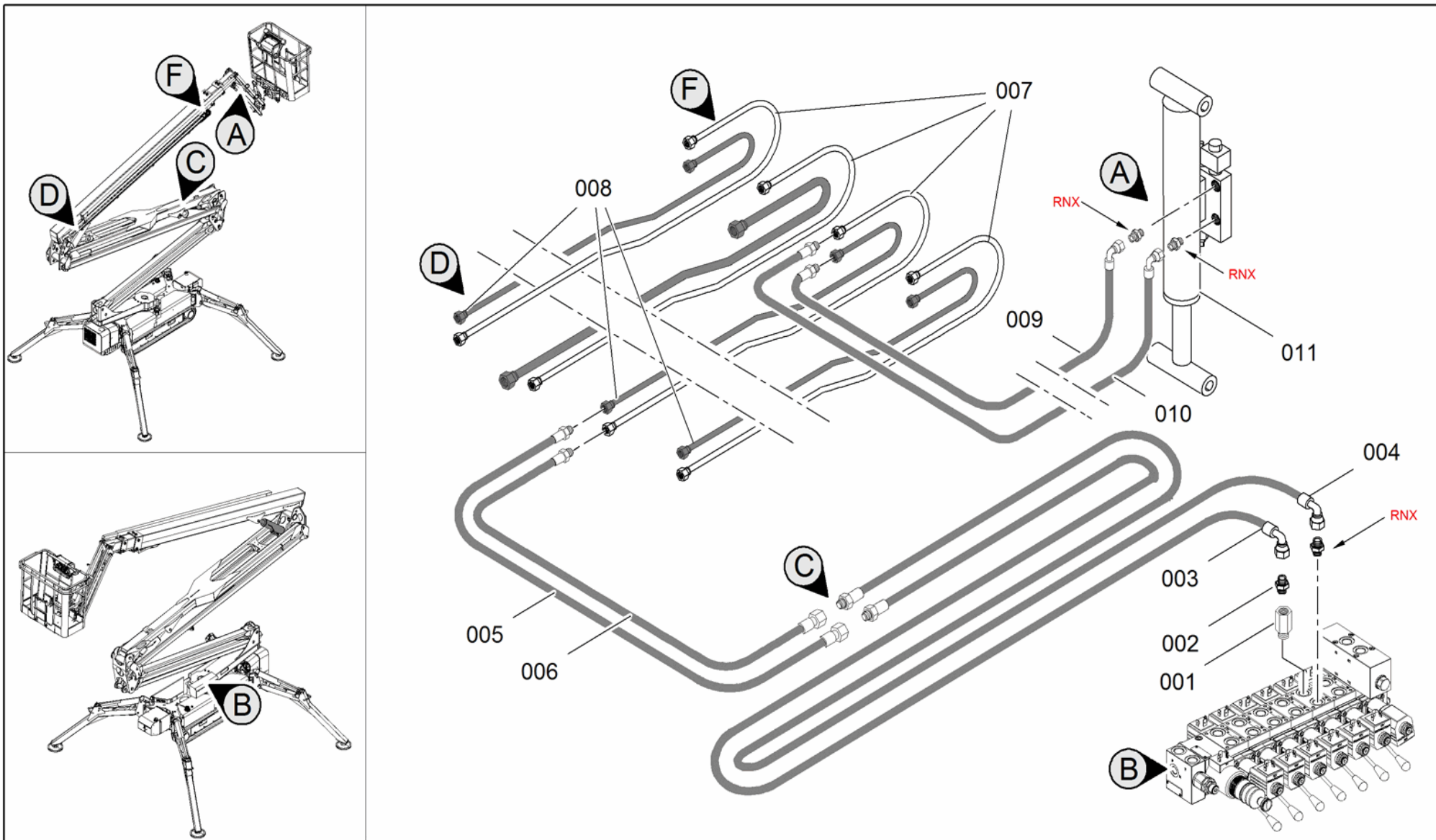

 JIB HYDRAULIC SYSTEM

INSTALACIÓN HIDRÁULICA JIB 

 SYSTÈME HYDRAULIQUE JIB



 IMPIANTO JIBZYLINDER JIB ARM  JIB HYDRAULIC SYSTEMINSTALACIÓN HIDRÁULICA JIB  SYSTÈME HYDRAULIQUE JIB

POS	Codice	Q.tà	 Descrizione	 Description	 Designation	 Benennung	 Descripción
1	06466100	2 NR	tubo flessibile	flexible pipe	tuyau flexible	schlauch	tubo flexible
2	06468400	2 NR	tubo rigido	rigid pipe	tuyau rigide	rohr	tubo rígido
3	06552000	2 NR	tubo rigido	rigid pipe	tuyau rigide	rohr	tubo rígido
4	06466600	1 NR	tubo flessibile	flexible pipe	tuyau flexible	schlauch	tubo flexible
5	06466700	1 NR	tubo flessibile	flexible pipe	tuyau flexible	schlauch	tubo flexible
6	26477900	1 NR	cilindro	cylinder	vérin	zylinder	cilindro

 IMPIANTO IDRAULICO LIVELLAMENTO

 LEVELING CYLINDERS HYDRAULIC SYSTEM

 SYSTÈME HYDRAULIQUE CYLINDRES BRAS

HYDRAULIKANLAGE ZYLINDER ARM 

INSTALACIÓN HIDRÁULICA CILINDROS BRAZOS 

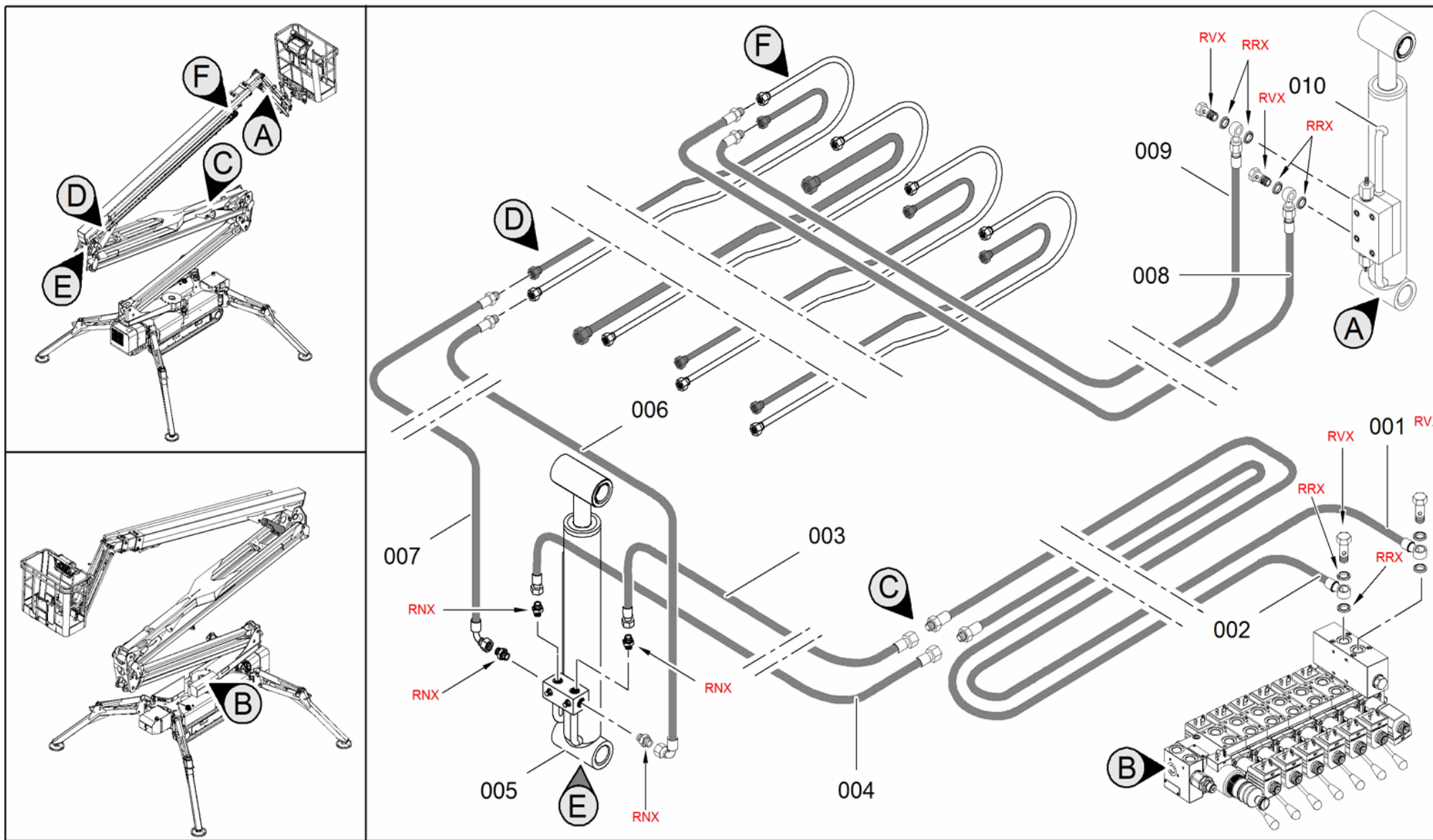





 IMPIANTO IDRAULICO LIVELLAMENTO

HYDRAULIKANLAGE ZYLINDER ARM 

 LEVELING CYLINDERS HYDRAULIC SYSTEM

INSTALACIÓN HIDRÁULICA CILINDROS BRAZOS 

 SYSTÈME HYDRAULIQUE CYLINDRES BRAS

POS	Codice	Q.tà	 Descrizione	 Description	 Designation	 Benennung	 Descripción
1	06466300	2 NR	tubo flessibile	flexible pipe	tuyau flexible	schlauch	tubo flexible
2	06466500	2 NR	tubo flessibile	flexible pipe	tuyau flexible	schlauch	tubo flexible
3	06468300	3 NR	tubo rigido	rigid pipe	tuyau rigide	rohr	tubo rígido
4	06466800	2 NR	tubo flessibile	flexible pipe	tuyau flexible	schlauch	tubo flexible
5	26269600	1 NR	cilindro	cylinder	vérin	zylinder	cilindro
6	26269500	1 NR	cilindro	cylinder	vérin	zylinder	cilindro
7	07593300	1 NR	raccordo prolunga m-f ¼ h=20	fitting	raccord	anschluss	conexión

 IMPIANTO IDRAULICO ROTAZIONE CESTO

HYDRAULIKANLAGE KORBSCHWENKUNG 

 CAGE ROTATION HYDRAULIC SYSTEM

INSTALACIÓN HIDRÁULICA ROTACIÓN CESTA 

 SYSTÈME HYDRAULIQUE ROTATION PANIER

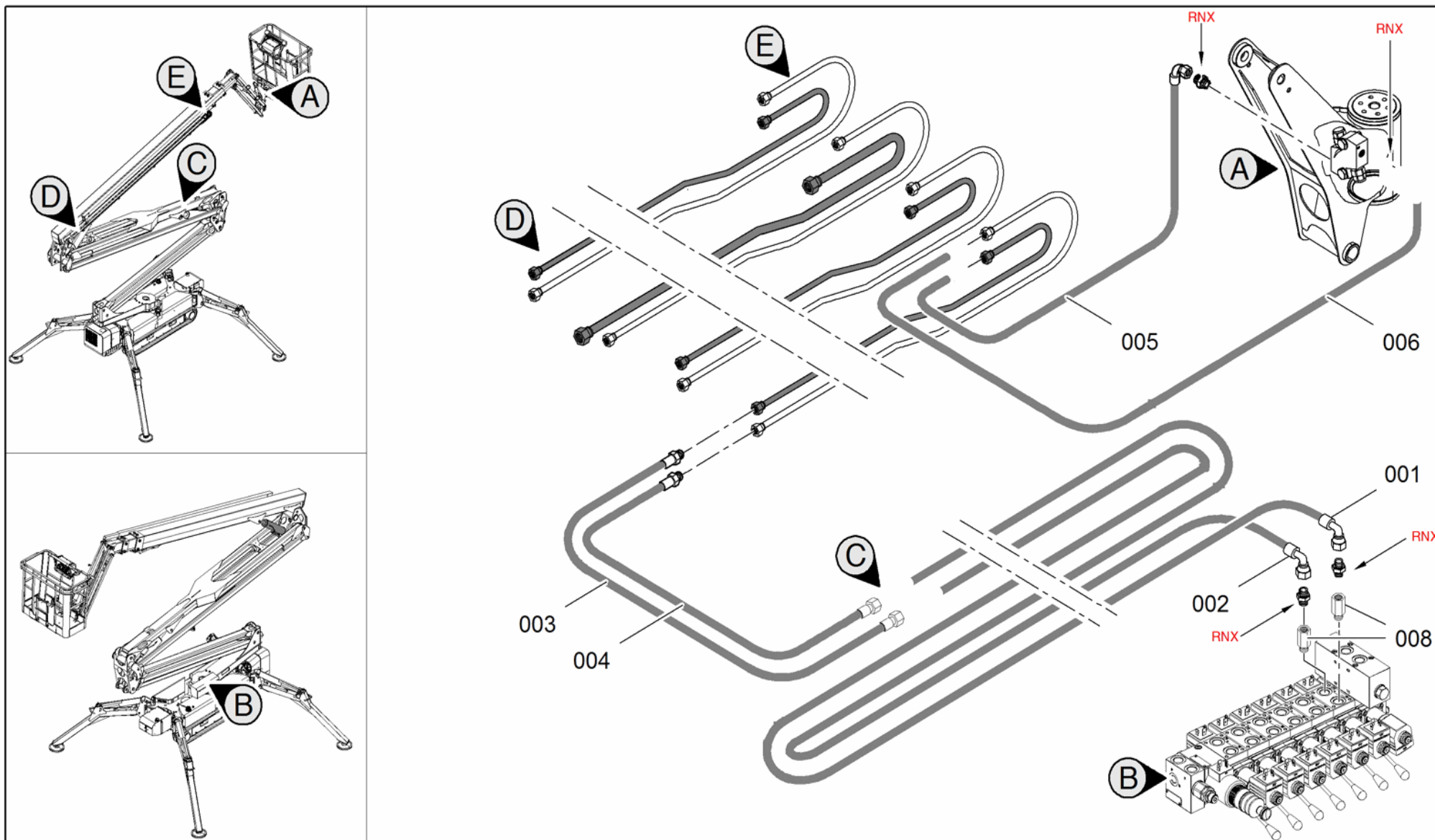





 IMPIANTO IDRAULICO ROTAZIONE CESTO



HYDRAULIKANLAGE KORBSCHWENKUNG 



 CAGE ROTATION HYDRAULIC SYSTEM

INSTALACIÓN HIDRÁULICA ROTACIÓN CESTA 

 SYSTÈME HYDRAULIQUE ROTATION PANIER

POS Codice	Q.tà	 Descrizione	 Description	 Designation	 Benennung	 Descripción
1 06466200	2 NR	tubo flessibile	flexible pipe	tuyau flexible	schlauch	tubo flexible
4 06466900	2 NR	tubo flessibile	flexible pipe	tuyau flexible	schlauch	tubo flexible
5 2648910001	1 NR	valvola idraulica	hydraulic valve	valve hydraulique	valve hydraulique	válvula hidráulica

 IMPIANTO IDRAULICO ARIA COMPRESSA  
 COMPRESSED AIR HYDRAULIC SYSTEM  
 SYSTÈME HYDRAULIQUE AIR COMPRIMÉ

HYDRAULIKANLAGE DRUCKLUFT   
INSTALACIÓN HIDRÁULICA AIRE COMPRIMIDO 

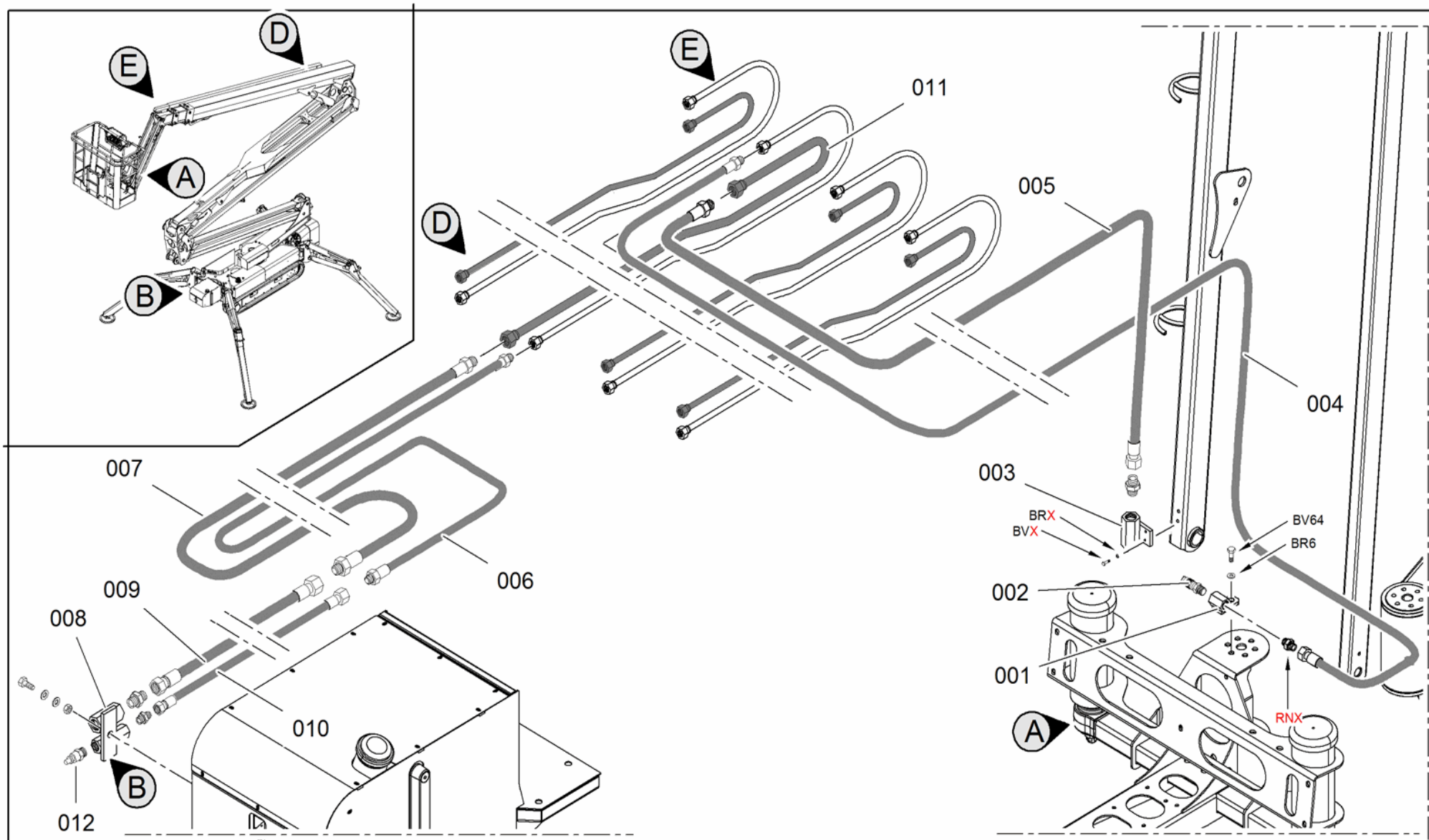





 IMPIANTO IDRAULICO ARIA COMPRESSA

HYDRAULIKANLAGE DRUCKLUFT 

 COMPRESSED AIR HYDRAULIC SYSTEM

INSTALACIÓN HIDRÁULICA AIRE COMPRIMIDO 

 SYSTÈME HYDRAULIQUE AIR COMPRIMÉ

POS Codice	Q.tà	 Descrizione	 Description	 Designation	 Benennung	 Descripción
1 05509900	1 NR	innesto rapido	quick coupling	raccord rapide	schnellkupplung	conexión rápida
2 04845100	1 NR	supporto	support	support	halterung	soporte
3 06466400	1 NR	tubo flessibile	flexible pipe	tuyau flexible	schlauch	tubo flexible
5 06467000	1 NR	tubo flessibile	flexible pipe	tuyau flexible	schlauch	tubo flexible
7 05580200	1 NR	rubinetto	faucet	robinet	wasserhahn	grifo



 CILINDRI

ZYLINDER 



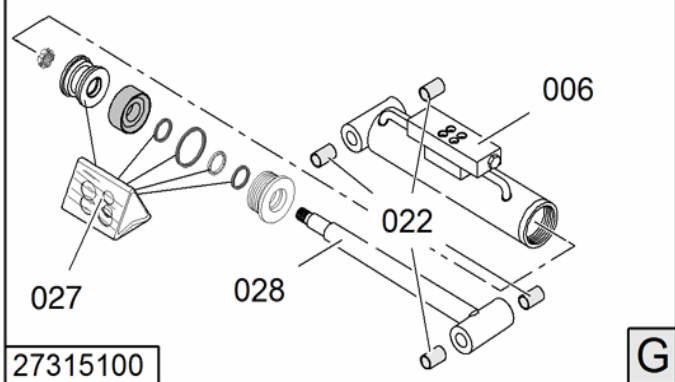
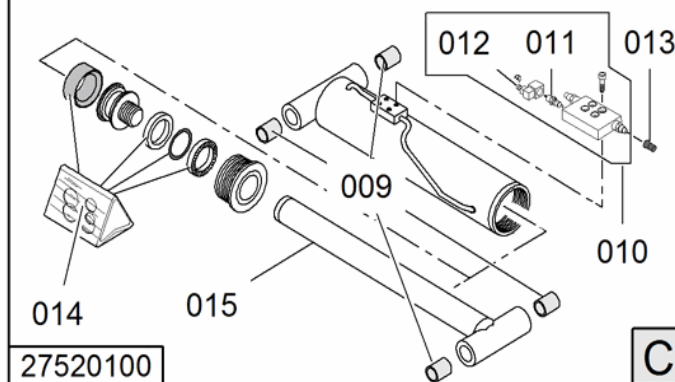
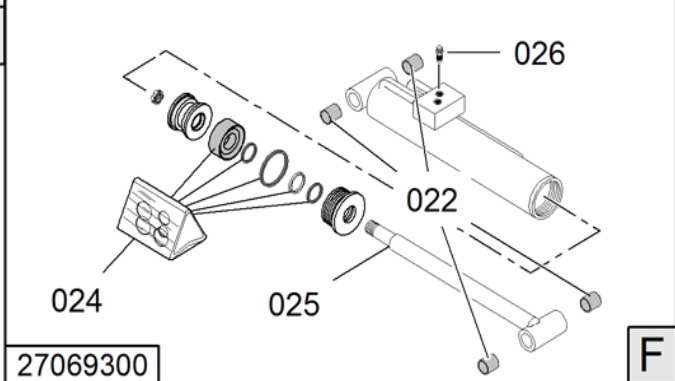
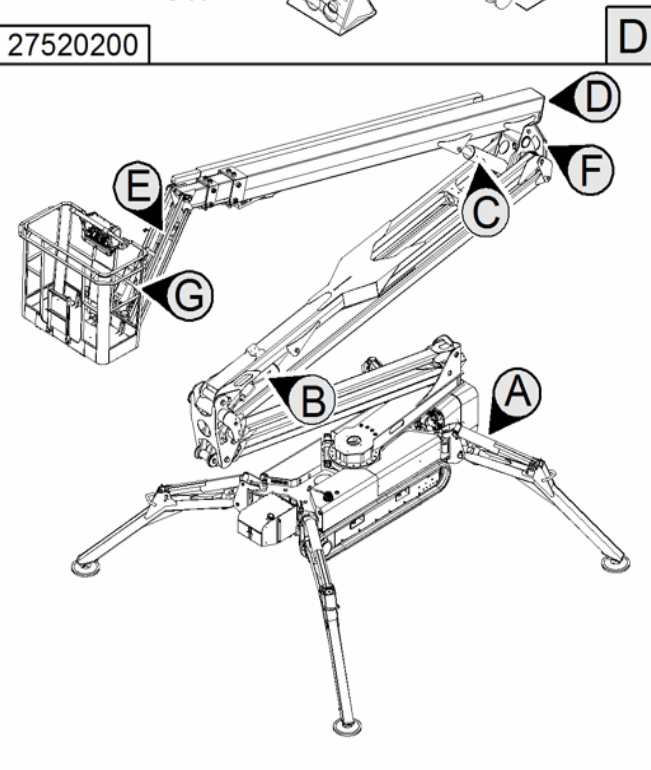
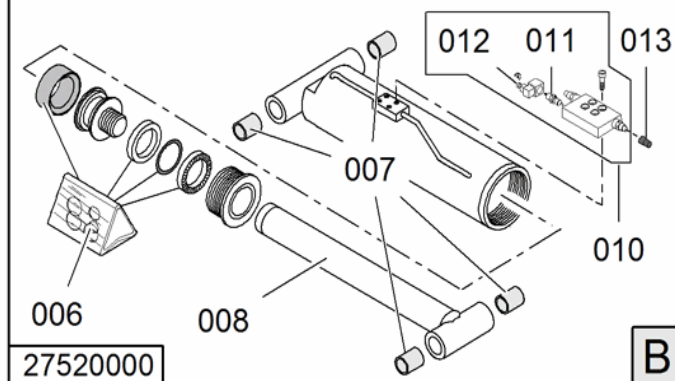
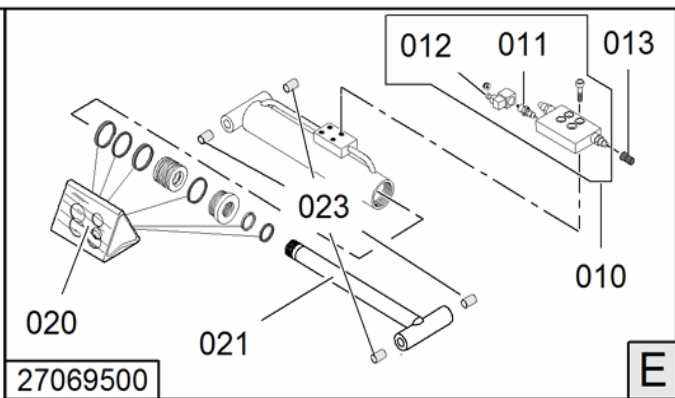
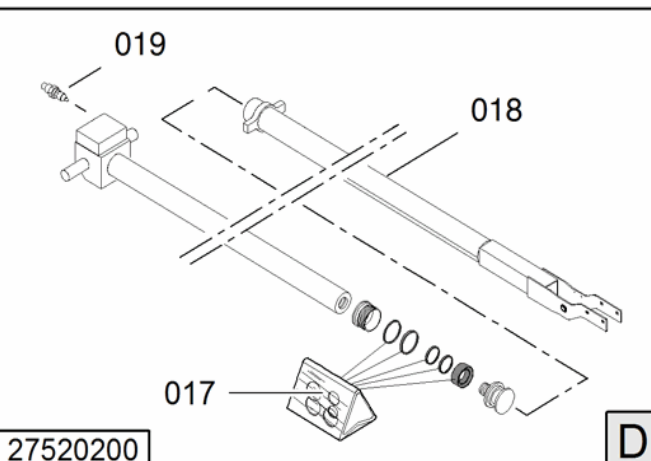
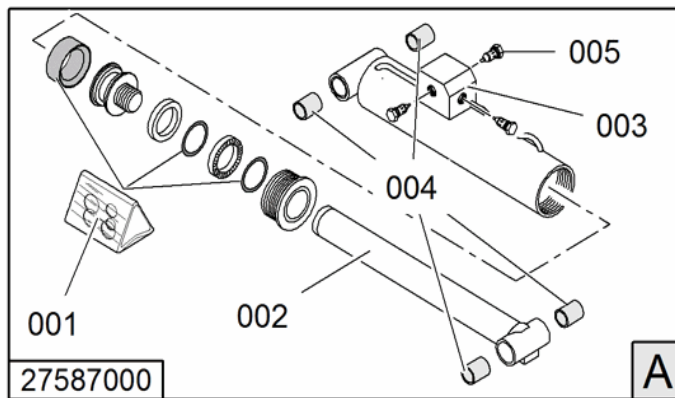

 CYLINDERS

CILINDROS 





 CYLINDRES



 CILINDRIZYLINDER  CYLINDERSCILINDROS  CYLINDRES

POS Codice	Q.tà	 Descrizione	 Description	 Designation	 Benennung	 Descripción
1 2629800001	1 NR	kit guarnizioni	gasket kit	kit joints	dichtungssatz	kit guarniciones
2 2629800002	1 NR	stelo	rod	tige	schaft	vástago
3 2629800003	1 NR	blocchetto	block	bloc	block	bloque
4 2628180003	4 NR	boccola	bush	douille	buchse	casquillo
5 1541150011	3 NR	valvola idraulica	hydraulic valve	valve hydraulique	valve hydraulique	válvula hidráulica
6 2644250004	1 NR	kit guarnizioni	gasket kit	kit joints	dichtungssatz	kit guarniciones
7 2644250005	1 NR	sensore lineare con lettura 435mm	sensor linear with range 435mm	capteur	sensor	sensor
8 2644250002	1 NR	stelo	rod	tige	schaft	vástago
9 2644250003	4 NR	boccola	bush	douille	buchse	casquillo
10 26119300	1 NR	valvola idraulica	hydraulic valve	valve hydraulique	valve hydraulique	válvula hidráulica
11 0552550001	1 NR	elettrovalvola	solenoid valve	électrovanne	magnetventil	electroválvula
12 0552550003	1 NR	bobina	coil	bobine	spule	bobina
13 05576200	2 NR	protezione	protection	protection	schutz	protección
13 05576200	6 NR	protezione	protection	protection	schutz	protección
14 2644260001	1 NR	kit guarnizioni	gasket kit	kit joints	dichtungssatz	kit guarniciones
15 2666590001	1 NR	stelo	rod	tige	schaft	vástago

 CILINDRIZYLINDER  CYLINDERSCILINDROS  CYLINDRES

POS Codice	Q.tà	 Descrizione	 Description	 Designation	 Benennung	 Descripción
16 2627880005	4 NR	boccola	bush	douille	buchse	casquillo
17 2687400001	1 NR	kit guarnizioni	gasket kit	kit joints	dichtungssatz	kit guarniciones
18 2687400002	1 NR	stelo	cylinder rod	tige de verin	rod-zylinder	barra de cilindro
19 05525600	1 NR	valvola idraulica	hydraulic valve	valve hydraulique	valve hydraulique	válvula hidráulica
20 2647790001	1 NR	kit guarnizioni	gasket kit	kit joints	dichtungssatz	kit guarniciones
21 2647790002	1 NR	stelo	rod	tige	schaft	vástago
22 2627890006	4 NR	boccola	bush	douille	buchse	casquillo
23 2644260004	1 NR	sensore lineare cilindro con lettura 570mm	sensor linear cylinder with range 570mm	capteur	sensor	sensor
24 2626950001	1 NR	kit guarnizioni	gasket kit	kit joints	dichtungssatz	kit guarniciones
25 2626950002	1 NR	stelo	rod	tige	schaft	vástago
26 2588290008	1 NR	vite	screw	vis	schraube	tornillo
27 2626960001	1 NR	kit guarnizioni	gasket kit	kit joints	dichtungssatz	kit guarniciones
28 2626960002	1 NR	stelo	rod	tige	schaft	vástago
29 1553870008	1 NR	valvola idraulica	hydraulic valve	valve hydraulique	valve hydraulique	válvula hidráulica

 COMPONENTI IMPIANTO ELETTRICO

 ELECTRICAL SYSTEM COMPONENTS

 COMPOSANTS INSTALLATION ÉLECTRIQUE

KOMPONENTEN ELEKTROANLAGE 



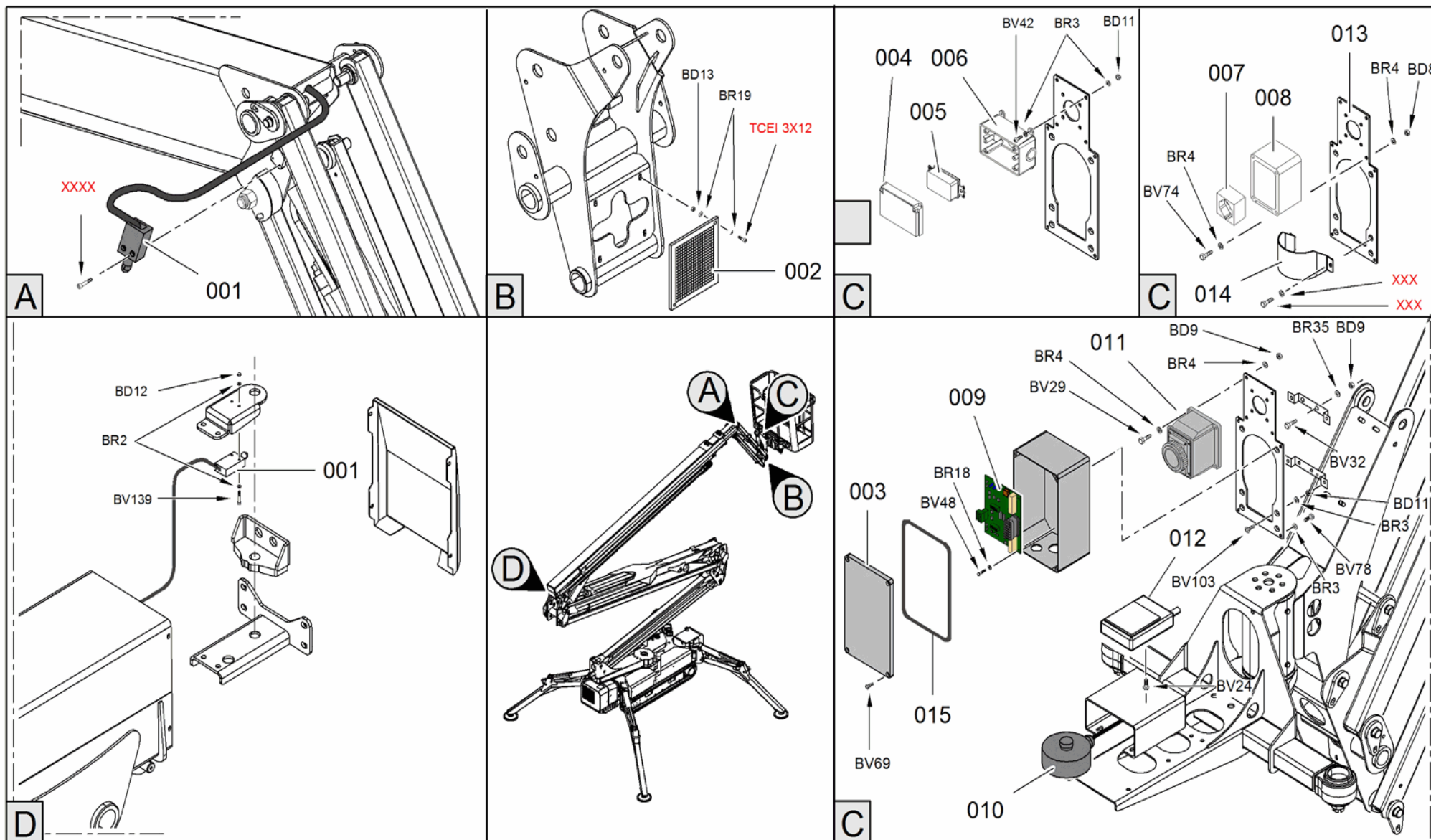

COMPONENTES INSTALACIÓN ELÉCTRICA 



 COMPONENTI IMPIANTO ELETTRICO

 KOMponenten ELEKTROANLAGE 
 ELECTRICAL SYSTEM COMPONENTS

 COMPONENTES INSTALACIÓN ELÉCTRICA 
 COMPOSANTS INSTALLATION ÉLECTRIQUE

POS Codice	Q.tà	 Descrizione	 Description	 Designation	 Benennung	 Descripción
1 17194600	1 NR	scatola elettrica versione con pedale	electric box pedal version	boîte électrique	elektrogehäuse	caja eléctrica
1 17194700	1 NR	scatola elettrica versione senza pedale non per macchine jlg	electric box without pedal version no jlg machine	boîte électrique	elektrogehäuse	caja eléctrica
2 27133100	1 NR	scheda elettronica sensore di carico (scatola in alluminio)	electronic board load sensor (aluminum case)	fiche électrique	elektronische platine	placa electrónica
2 27480300	1 NR	scheda elettronica sensore di carico (performance-plus-australia)	electronic board load sensor (performance-plus-australia)	fiche électrique	elektronische platine	placa electrónica
3 27073800	1 NR	cover prese usa al cesto, receptacle box part n°:1671207	cover take usa to basket, receptacle box part n°:1671207	connecteur	verbinger	conectador
4 27073900	1 NR	plug prese usa al cesto, receptacle part n°:4460346	plug socket to basket usa, receptacle part n°:4460346	connecteur	verbinger	conectador
5 27073700	1 NR	box prese usa al cesto, receptacle part n°:0861731	box take usa to basket, receptacle part n°:0861731	connecteur	verbinger	conectador





 COMPONENTI IMPIANTO ELETTRICO

 KOMponenten ELEKTROANLAGE

 ELECTRICAL SYSTEM COMPONENTS

 COMPONENTES INSTALACIÓN ELÉCTRICA

 COMPOSANTS INSTALLATION ÉLECTRIQUE

POS Codice	Q.tà	 Descrizione	 Description	 Designation	 Benennung	 Descripción
6 07173300	1 NR	piastra versione ce	plate ce version	platine	platte	placa
6 07173800	1 NR	piastra versione ansi	plate ansi version	platine	platte	placa
7 1585570005	1 NR	presa elettrica 230v	electrical socket 230v	prise électrique	steckdose	enchufe eléctrico
7 1591700002	1 NR	presa elettrica 110v	electrical socket 110v	prise électrique 110v	steckdose 110v	enchufe eléctrico 110v
7 17510400	1 NR	cavo 3 poli 220-110v x23-x700 metri da base a cesto	cable 3 wires 220-110v x23-x700 from base to platform	câble électrique	elektrokabel	cable eléctrico
8 25611500	1 NR	cella di carico	load cell	cellule de charge	messdose	célula de carga
9 27031700	1 NR	interuttore a pedale	foot switch	interrupteur	interruptores	interruptor
10 1591270002	1 NR	catarifrangente	reflector	catadioptré	reflektor	catadióptrico
11 1591270003	1 NR	microinterruttore 2 contatti nc testina rotella acciaio cavo lungo 2 metri	microswitch 2 nc contacts head steel wheel long cable 2m	microinterrupteur	mikroschalter	microinterruptor
12 1556350060	1 NR	scatola elettrica stop gas/diesel (chiave, spia, 2puls, pg13,5 post)	electrical box stop gas / diesel (key, indicator, 2 swithc, pg13.5 back)	boîte électrique	elektrogehäuse	caja eléctrica
12 17044500	1 NR	scatola elettrica	electric box	boîte électrique	elektrogehäuse	caja eléctrica





 COMPONENTI IMPIANTO ELETTRICO

 KOMponenten ELEKTROANLAGE

 ELECTRICAL SYSTEM COMPONENTS

 COMPONENTES INSTALACIÓN ELÉCTRICA

 COMPOSANTS INSTALLATION ÉLECTRIQUE

POS Codice	Q.tà	 Descrizione	 Description	 Designation	 Benennung	 Descripción
13 1628400002	1 NR	spia	pilot light	témoin	kontrollleuchte	indicador luminoso
14 1591270004	1 NR	pulsante	button	bouton	druckknopf	botón
15 1556350068	1 NR	selettore a leva 3 posizioni	3 position switch lever	sélecteur	wählschalter	selector
15 1651290001	1 NR	selettore 3 posizioni per chiave	3 position selector switch for key	sélecteur	wählschalter	selector
16 1651290015	1 NR	chiave	key	clés	schlüssel	clave
17 1628400001	1 NR	pulsante	button	bouton	druckknopf	botón
18 17048200	1 NR	scatola elettrica	electric box	boîte électrique	elektrogehäuse	caja eléctrica
19 061187Y1	1 NR	piastra	plate	platine	platte	placa
20 06118500	1 NR	lamiera piegata	folded plate	tôle pliée	blech gebogen	chapa doblada
21 1591270001	1 NR	fotocellula	photocell	cellule photo-électrique	photozelle	fotocélula
22 159127000101	1 NR	cavo elettrico	electric cable	câble électrique	elektrokabel	cable eléctrico





 COMPONENTI IMPIANTO ELETTRICO

 KOMONENTEN ELEKTROANLAGE

 ELECTRICAL SYSTEM COMPONENTS

 COMPONENTES INSTALACIÓN ELÉCTRICA

 COMPOSANTS INSTALLATION ÉLECTRIQUE





POS Codice	Q.tà	 Descrizione	 Description	 Designation	 Benennung	 Descripción
23 1556350015	1 NR	interuttore automatico magnetotermico 220v	automatic thermal switch 220v	interrupteur	interruptores	interruptor
23 1556350063	1 NR	interuttore automatico magnetotermico 110-120v 25a (fino a c170000355 montato c16 su macchine 120v)	automatic thermal switch 110-120v 25a (until c170000355 mounted c16 on 120v machines)	interrupteur	interruptores	interruptor
24 1556350013	1 NR	spina fissa 230v 90°	plug 230v 90 °	cheville	stif	clavija
24 1556350064	1 NR	spina fissa 110v 90°	plug 110v 90°	cheville	stif	clavija
24 27074000	1 NR	terminal presa usa a terra, conn plug part n°:4460138	terminal ground socket usa, conn plug part n °: 4460138	connecteur	verbinger	conectador
25 1651290003	1 NR	scatola elettrica	electric box	boîte électrique	elektrogehäuse	caja eléctrica
26 1651290004	1 NR	scheda	board	fiche	platine	placa
27 17393900	1 NR	cavo elettrico	electric cable	câble électrique	elektrokabel	cable eléctrico
28 07231500	1 NR	scheda elettronica	electronic board	fiche électrique	elektronische platine	placa electrónica



 COMPONENTI IMPIANTO ELETTRICO

 KOMponenten ELEKTROANLAGE 
 ELECTRICAL SYSTEM COMPONENTS

 COMPONENTES INSTALACIÓN ELÉCTRICA 
 COMPOSANTS INSTALLATION ÉLECTRIQUE

POS Codice	Q.tà	 Descrizione	 Description	 Designation	 Benennung	 Descripción
29 17473700	1 NR	slitta per connettore 24 vie	slide for 24-way connector	coulisseau	schlitten	corredera
30 17473600	1 NR	parte di connettore 24vie	connector part 24 way	connecteur	verbinger	conectador
31 17306300	18 NR	puntalino femmina per connettore 56 vie scheda master d=1.5	ferrule female connector 56 way main board d = 1.5	butée femelle connecteur 56 voies carte master d = 1.5	auflagestift buchse 56-wege-verbinder masterplatine d = 1.5	conector punta hembra 56 vías tarjeta master d=1,5
32 17473800	6 NR	puntalino femmina per connettore 24 vie scheda cella di carico d=2.8	ferrule female connector 24 way board load cell d = 2.8	embout femelle pour connecteur 24 voies carte cellule de charge d=2.8	verschraubung buchse für 24-wege-verbinder korblast-platine d=2,8	puntal hembra para conector 24 vías celula de carga d=2.8
33 17229100	1 NR	cavo sensore cilindro 1-2° braccio	sensor cable boom cylinder 1-2	câble électrique	elektrokabel	cable eléctrico
34 17229000	1 NR	cavo sensore cilindro 3° braccio	sensor cable cylinder 3rd boom	câble électrique	elektrokabel	cable eléctrico

 COMPONENTI IMPAINTO ELETTRICO

 ELECTRICAL SYSTEM COMPONENTS

 COMPOSANTS INSTALLATION ÉLECTRIQUE

KOMPONENTEN ELEKTROANLAGE 

COMPONENTES INSTALACIÓN ELÉCTRICA 

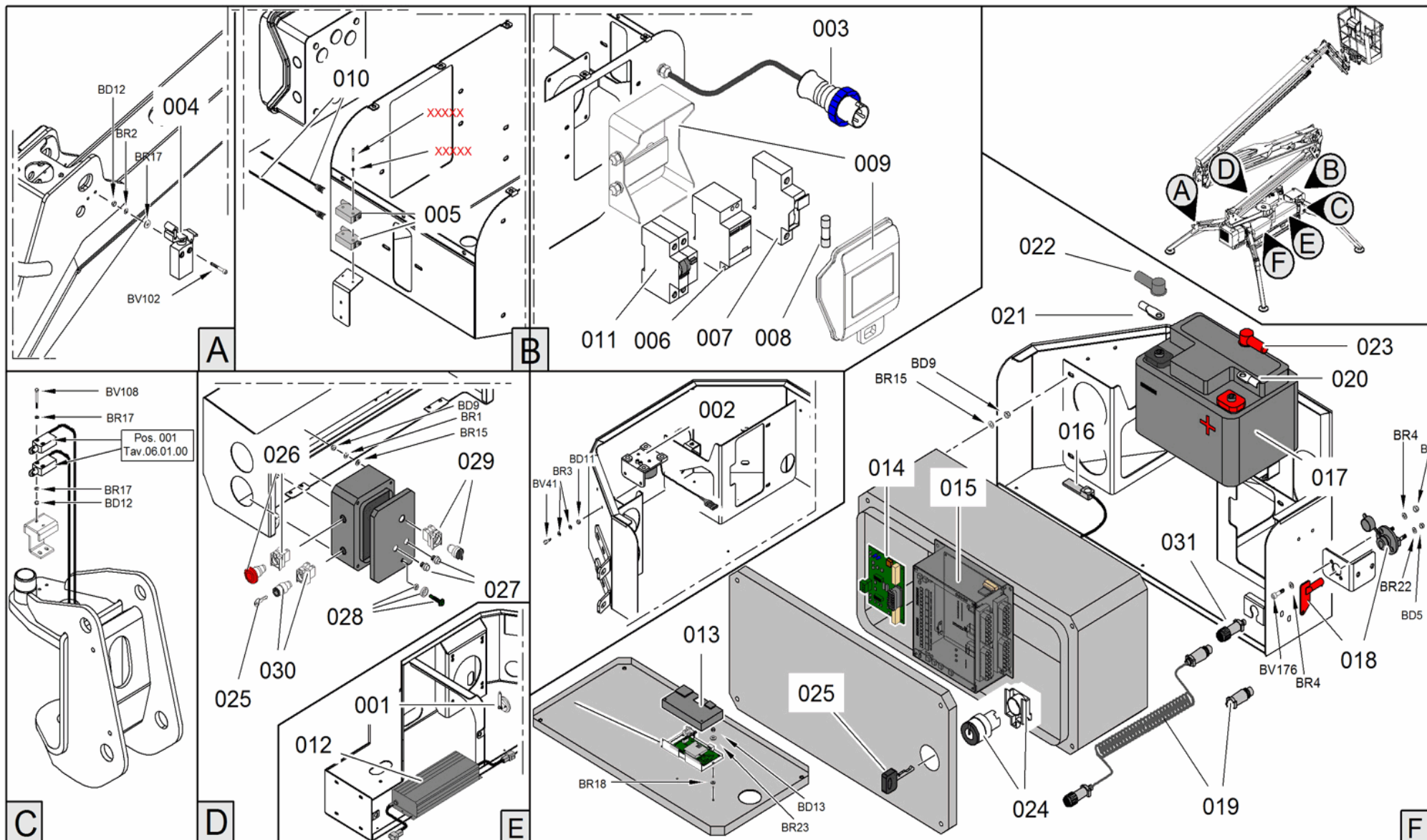





 COMPONENTI IMPAINTO ELETTRICO

 KOMponenten ELEKTROANLAGE

 ELECTRICAL SYSTEM COMPONENTS

 COMPONENTES INSTALACIÓN ELÉCTRICA

 COMPOSANTS INSTALLATION ÉLECTRIQUE

POS Codice	Q.tà	 Descrizione	 Description	 Designation	 Benennung	 Descripción
1 1651290002	1 NR	microinterruttore 2 contatti nc testina rotella acciaio cavo lungo 5 metri	micro switch 2 nc contacts head steel wheel long cable 5 meter	microinterruteur	mikroschalter	microinterruptor
2 1556350034	1 NR	spia	pilot light	témoin	kontrollleuchte	indicador luminoso
3 1556350035	1 NR	lampadina	lamp	ampoule	glühbirne	bombilla
4 1556350036	1 NR	corpo	body	corps	gehäuse	cuerpo
5 1590900002	1 NR	microinterruttore 2 contatti nc testina braccio e rotella in acciaio cavo lungo 2 metri	2 nc contacts microswitch head arm and wheel steel long cable 2m	microinterruteur	mikroschalter	microinterruptor
6 1591270003	1 NR	microinterruttore 2 contatti nc testina rotella acciaio cavo lungo 2 metri	microswitch 2 nc contacts head steel wheel long cable 2m	microinterruteur	mikroschalter	microinterruptor
7 1585570006	1 NR	selettore	selector	sélecteur	wählschalter	selector
8 1602410001	1 NR	adattatore	adapter	adaptateur	adapter	adaptador
9 1651290015	1 NR	chiave	key	clés	schlüssel	clave





 COMPONENTI IMPAINTO ELETTRICO

KOMPONENTEN ELEKTROANLAGE 

 ELECTRICAL SYSTEM COMPONENTS

COMPONENTES INSTALACIÓN ELÉCTRICA 





 COMPOSANTS INSTALLATION ÉLECTRIQUE

POS Codice	Q.tà	 Descrizione	 Description	 Designation	 Benennung	 Descripción
10 26608500	1 NR	scheda elettronica	electronic board	fiche électrique	elektronische platine	placa electrónica
10 27321800	1 NR	scheda modem con nuovo processore (supporto a ricambio 07396000) per macchine australia e plus	modem card with new cpu (mounting spare parts 07396000) for australian and plus machines	carte modem avec un nouveau processeur	modemkarte mit neuen prozessor	modem tarjeta con nuevo procesador
11 05971800	1 NR	antivibrante	anti-vibrating	anti - vibrant	vibrationsdämpfer	antivibrante
12 06458600	1 NR	lamiera	plate	tôle	blech	chapa

 COMPONENTI IMPAINTO ELETTRICO

 KOMponenten ELEKTROANLAGE 
 ELECTRICAL SYSTEM COMPONENTS





 COMPONENTES INSTALACIÓN ELÉCTRICA 
 COMPOSANTS INSTALLATION ÉLECTRIQUE

POS Codice	Q.tà	 Descrizione	 Description	 Designation	 Benennung	 Descripción
13 26608200	1 NR	scheda elettronica (+17172600 se fornita a ricambio con software installato)	electronic board (+17172600 if supplied parts with software installed)	fiche électronique	elektronische platine	tarjeta electrónica
13 26907000	1 NR	scheda elettrica versione litio (+17172600 se fornita a ricambio con software installato)	electric board lithium version (+17172600 if supplied parts with software installed)	fiche électrique	elektrische platine	tarjeta eléctrica
13 27179900	1 NR	scheda elettronica nuovo processore (per macchine australia e plus) (+17172600 se fornita a ricambio con software installato)	electronic board new cpu (for australian and plus machines) (+17172600 if supplied parts with software installed)	fiche électronique	elektronische platine	tarjeta electrónica
13 27180000	1 NR	scheda elettrica nuovo processore versione litio (+17172600 se fornita a ricambio con software installato)	electric board new chip lithium version (+17172600 if supplied parts with software installed)	fiche électrique	elektrische platine	tarjeta eléctrica
14 17049200	1 NR	scatola elettrica	electric box	boîte électrique	elektrogehäuse	caja eléctrica

 COMPONENTI IMPAINTO ELETTRICO

 KOMponenten ELEKTROANLAGE 
 ELECTRICAL SYSTEM COMPONENTS





 COMPONENTES INSTALACIÓN ELÉCTRICA 
 COMPOSANTS INSTALLATION ÉLECTRIQUE

POS Codice	Q.tà	 Descrizione	 Description	 Designation	 Benennung	 Descripción
15 26608600	1 NR	antenna	antenna	antenne	antenne	antena
15 27396100	1 NR	antenna	aerial	antenne	antenne	antena
16 1651290014	1 NR	scheda	board	fiche	platine	placa
17 04774900	1 NR	stacca batteria	battery cut-off device	coupe batterie	batterietrennschalter	corta-batería
18 06551000	2 NR	tirante	tie rod	tirant	turmgestänge	tirante
19 06543500	1 NR	staffa	bracket	étrier	haltebügel	estribo
19 07243300	1 NR	lamiera supporto scheda e switching (da c170000340 per macchine ansi)	braket for card and switching (from c170000340 for ansi machines)	support	halterung	soporte
20 17047500	1 NR	scatola elettrica	electric box	boîte électrique	elektrogehäuse	caja eléctrica
20 17348200	1 NR	scatola elettrica switching (a partire da c170000340 per macchine ansi)	switching electrical box (from c170000340 for ansi machines)	boîte électrique	elektrogehäuse	caja eléctrica
21 26608400	1 NR	scheda elettronica	electronic board	fiche électrique	elektronische platine	placa electrónica
21 27268500	1 NR	scheda trasformatore resinata (da c170000340 per macchine ansi)	transformer board resinate (from c170000340 for ansi machines)	fiche électrique	elektronische platine	placa electrónica

 COMPONENTI IMPAINTO ELETTRICO

 KOMponenten ELEKTROANLAGE 
 ELECTRICAL SYSTEM COMPONENTS



 COMPONENTES INSTALACIÓN ELÉCTRICA 
 COMPOSANTS INSTALLATION ÉLECTRIQUE

POS Codice	Q.tà	 Descrizione	 Description	 Designation	 Benennung	 Descripción
22 1628400004	1 NR	trasformatore 230v	transformer 230v	transformateur 230v	transformator 230v	transformador 230v
22 26610700	1 NR	trasformatore 110v	transformer 110v	transformateur 110v	transformator 110v	transformador 110v
22 27249800	1 NR	alimentatore switching (da c170000340 per macchine ansi)	switching power supply (from c170000340 for ansi machines)	transformateur	transformator	transformador
23 26550700	1 NR	batteria	battery	batterie	batterie	batería
24 05561800	1 NR	lamiera	plate	tôle	blech	chapa
25 06543600	1 NR	piastra	plate	platine	platte	placa
26 16773800	1 NR	scheda elettronica	electronic board	fiche électrique	elektronische platine	placa electrónica
27 1666650002	1 NR	scatola elettrica	electric box	boîte électrique	elektrogehäuse	caja eléctrica
28 1666650001	1 NR	scheda elettronica	electronic board	fiche électrique	elektronische platine	placa electrónica
29 06922600	1 NR	supporto	support	support	halterung	soporte

 COMPONENTI IMPAINTO ELETTRICO

 KOMponenten ELEKTROANLAGE 
 ELECTRICAL SYSTEM COMPONENTS

 COMPONENTES INSTALACIÓN ELÉCTRICA 
 COMPOSANTS INSTALLATION ÉLECTRIQUE

POS Codice	Q.tà	 Descrizione	 Description	 Designation	 Benennung	 Descripción
30 17306000	1 NR	parte di connettore	connector part	connecteur	verbinger	conectador
30 17306100	1 NR	coperchio	cover	couvercle	deckel	tapa
30 17306200	1 NR	slitta	slide	coulisseau	schlitten	corredera
30 17306300	1 NR	puntalino femmina per connettore 56 vie scheda master d=1.5	ferrule female connector 56 way main board d = 1.5	butée femelle connecteur 56 voies carte master d = 1.5	auflagestift buchse 56-wege-verbinder masterplatine d = 1.5	conector punta hembra 56 vías tarjeta master d=1,5
31 06639100	1 NR	avvisatore acustico	acoustic alarm	détecteur acoustique	akustischer melder	sirena
32 07347900	1 NR	piastra adattamento	plate adapter	reglage de la plaque	fussplattenverstellung	ajuste de la placa
33 07348600	2 NR	piastra filettata	threaded plate	plaque filetee	gewindeplatte	placa de rosca
34 05568700	1 NR	supporto	support	support	halterung	soporte
35 17473800	7 NR	puntalino femmina per connettore 24 vie scheda cella di carico d=2.8	ferrule female connector 24 way board load cell d = 2.8	embout femelle pour connecteur 24 voies carte cellule de charge d=2.8	verschraubung buchse für 24-wege-verbinder korblast-platine d=2,8	puntal hembra para conector 24 vías celula de carga d=2.8
36 17473600	2 NR	parte di connettore 24vie	connector part 24 way	connecteur	verbinger	conectador
37 17473700	2 NR	slitta per connettore 24 vie	slide for 24-way connector	coulisseau	schlitten	corredera







 COMPONENTI IMPAINTO ELETTRICO

 KOMponenten ELEKTROANLAGE

 ELECTRICAL SYSTEM COMPONENTS

 COMPONENTES INSTALACIÓN ELÉCTRICA

 COMPOSANTS INSTALLATION ÉLECTRIQUE

POS Codice	Q.tà	 Descrizione	 Description	 Designation	 Benennung	 Descripción
38 17306300	19 NR	puntalino femmina per connettore 56 vie scheda master d=1.5	ferrule female connector 56 way main board d = 1.5	butée femelle connecteur 56 voies carte master d = 1.5	aufgestift buchse 56-wege-verbinder masterplatine d = 1.5	conector punta hembra 56 vías tarjeta master d=1,5
39 17506700	1 NR	kit banco programmazione schede piattaforme	programmation kit	kit programmation	programmationsatz	kit programacion
40 17639300	1 NR	kit aggiunta connettore e tappo per telematics jlg standard machines	plug connector kit for telematics jlg standard machines			
41 17626900	1 NR	cavo telecomando a terra 3s completo di connettore e tappo	cable remote ground 3s complete with plug connector	câble électrique	elektrokabel	cable eléctrico

 COMPONENTI IMPIANTO ELETTRICO LITIO

KOMPONENTEN ELEKTROANLAGE LITHIUM 

 ELECTRICAL SYSTEM COMPONENTS LITHIUM

COMPONENTES INSTALACIÓN ELÉCTRICA LITHIUM 

 COMPOSANTS INSTALLATION ÉLECTRIQUE LITHIUM

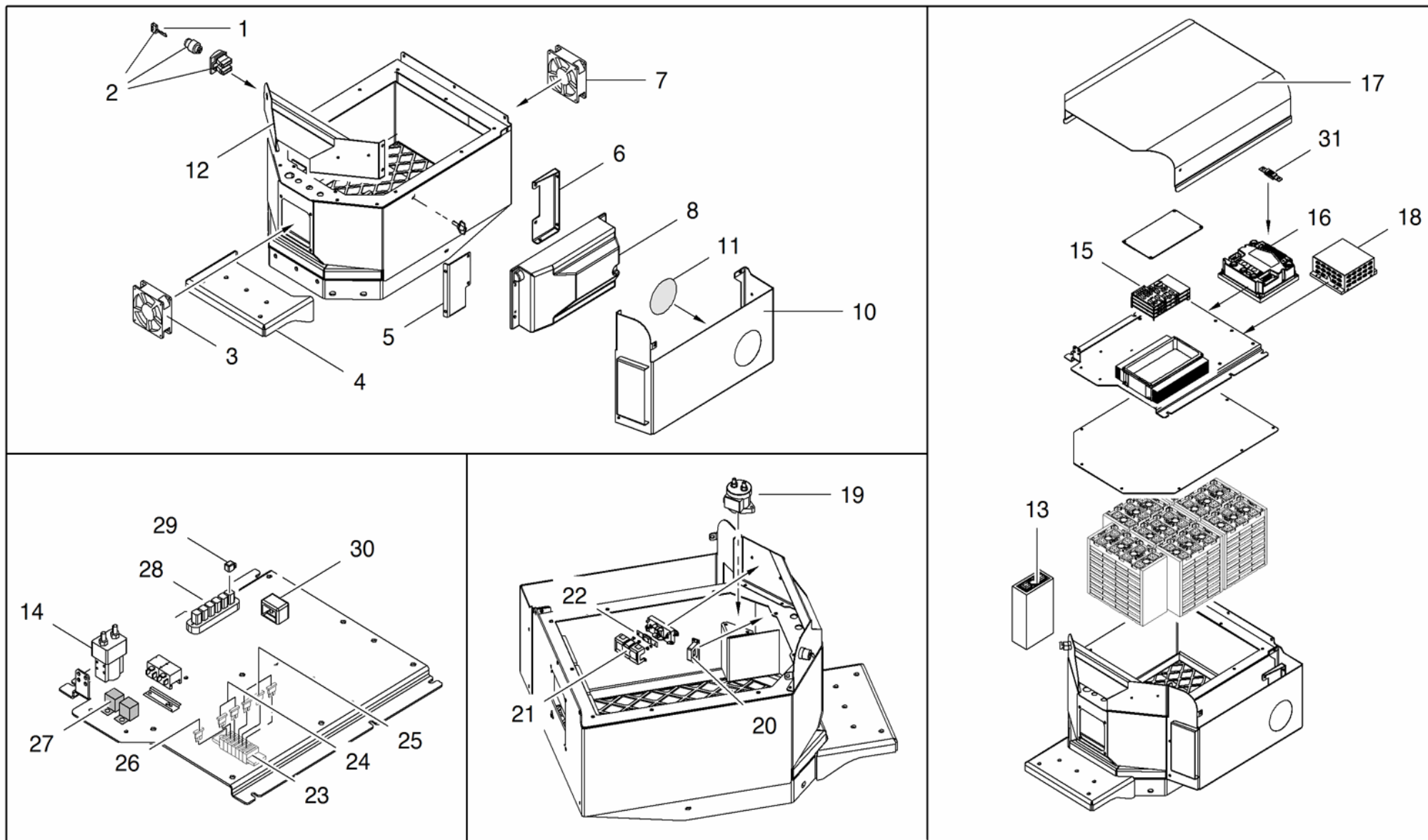





 COMPONENTI IMPIANTO ELETTRICO LITIO

 KOMponenten ELEKTROANLAGE LITHIUM

 ELECTRICAL SYSTEM COMPONENTS LITHIUM

 COMPONENTES INSTALACIÓN ELÉCTRICA LITHIUM





 COMPOSANTS INSTALLATION ÉLECTRIQUE LITHIUM

POS Codice	Q.tà	 Descrizione	 Description	 Designation	 Benennung	 Descripció
1 1692150002	1 NR	chiave accensione	ignition key	clef de démarrage	zündschlüssel	clave de encendido
2 1692150001	1 NR	blocchetto	block	bloc	block	bloque
3 26947600	1 NR	inverter	inverter	inverter	inverter	inverter
4 26429300	1 NR	teleruttore	remote-control switch	télérupteur	fernshalter	teleruptor
5 1690690021	1 NR	sensore lem (fino a matricola c170000329)	sensor lem (until serial c170000329)	capteur	sensor	sensor
5 1735210002	1 NR	trasduttore di corrente (da c170000330)	current transducer (from c170000330)	transformateur d'intensité (da c170000330)	strommessumformer (da c170000330)	transductor de corriente eléctrica (da c170000330)
6 1690690025	1 NR	ventola	fan	ventilateur	lüfterrad	ventilador
7 1690690002	1 NR	ventola posteriore	rear fan	ventilateur	lüfterrad	ventilador
8 1690690003	1 NR	blocchetto	fuse holders block	bloc	block	bloque
9 1690690020	1 NR	teleruttore	remote-control switch	télérupteur	fernshalter	teleruptor
10 1690690005	1 NR	relè	relay	relais	relais	relé
11 1690690006	1 NR	temporizzatore	timer	minuteur	timer	temporizador
12 26947900	1 NR	trasformatore	transformer	transformateur	transformator	transformador

 COMPONENTI IMPIANTO ELETTRICO LITIO

 KOMponenten ELEKTROANLAGE LITHIUM 
 ELECTRICAL SYSTEM COMPONENTS LITHIUM

 COMPONENTES INSTALACIÓN ELÉCTRICA LITHIUM 
 COMPOSANTS INSTALLATION ÉLECTRIQUE LITHIUM

POS Codice	Q.tà	 Descrizione	 Description	 Designation	 Benennung	 Descripción
13 1690690022	1 NR	cella singola versione a	single cell version a	cellule unique a	einzelzelle a	unicelulares a
13 1742410001	1 NR	cella litio versione b	cell lithium version b	cellule unique b	einzelzelle b	unicelulares b
14 1690690009	1 NR	coperchio	cover	couvercle	deckel	tapa
15 05760800	1 NR	fusibile 7,5 a	fuse 7,5 a	fusible 7,5 a	sicherungsdraht 7,5 a	fusible 7,5 a
16 1690690011	1 NR	fusibile 160a	fuse 160a	fusible 160a	sicherungsdraht 160a	fusible 160a
18 05760600	1 NR	fusibile 3a	fuse 3a	fusible 3a	sicherungsdraht 3a	fusible 3a
19 1737990001	1 NR	bms 72v nuova versione (da c170000352)	bms 72v new version (from c170000352)	bms 72v	bms 72v	bms 72v
19 1690690024	1 NR	bms 72v (fino a matricola c170000351)	bms 72v (until serial c170000351)	bms 72v	bms 72v	bms 72v
20 05760900	1 NR	fusibile 10a	fuse 10a	fusible 10a	sicherungsdraht 10a	fusible 10a
23 27022200	1 NR	scheda - can bus	board - can bus	fiche - can bus	platine - can bus	placa - can bus





 COMPONENTI IMPIANTO ELETTRICO LITIO

KOMPONENTEN ELEKTROANLAGE LITHIUM 

 ELECTRICAL SYSTEM COMPONENTS LITHIUM

COMPONENTES INSTALACIÓN ELÉCTRICA LITHIUM 

 COMPOSANTS INSTALLATION ÉLECTRIQUE LITHIUM

POS Codice	Q.tà	 Descrizione	 Description	 Designation	 Benennung	 Descripcìon
24 26947800	1 NR	carica batteria litio 230v	battery charger lithium 230v	charge batterie	batterielader	carga baterías
24 27085100	1 NR	caricabatterie 72v-110v lithium	lithium battery charger 72v-110v	lithium batterie 72v-110v	batterieladegerät 72v-110v lithium	cargador de batería 72v-110v litio
25 2694760001	1 NR	fusibile	fuse	fusible	sicherungsdraht	fusible

 TELECOMANDO

FERNSTEUERUNG 

 REMOTE CONTROL

TELECOMANDO 



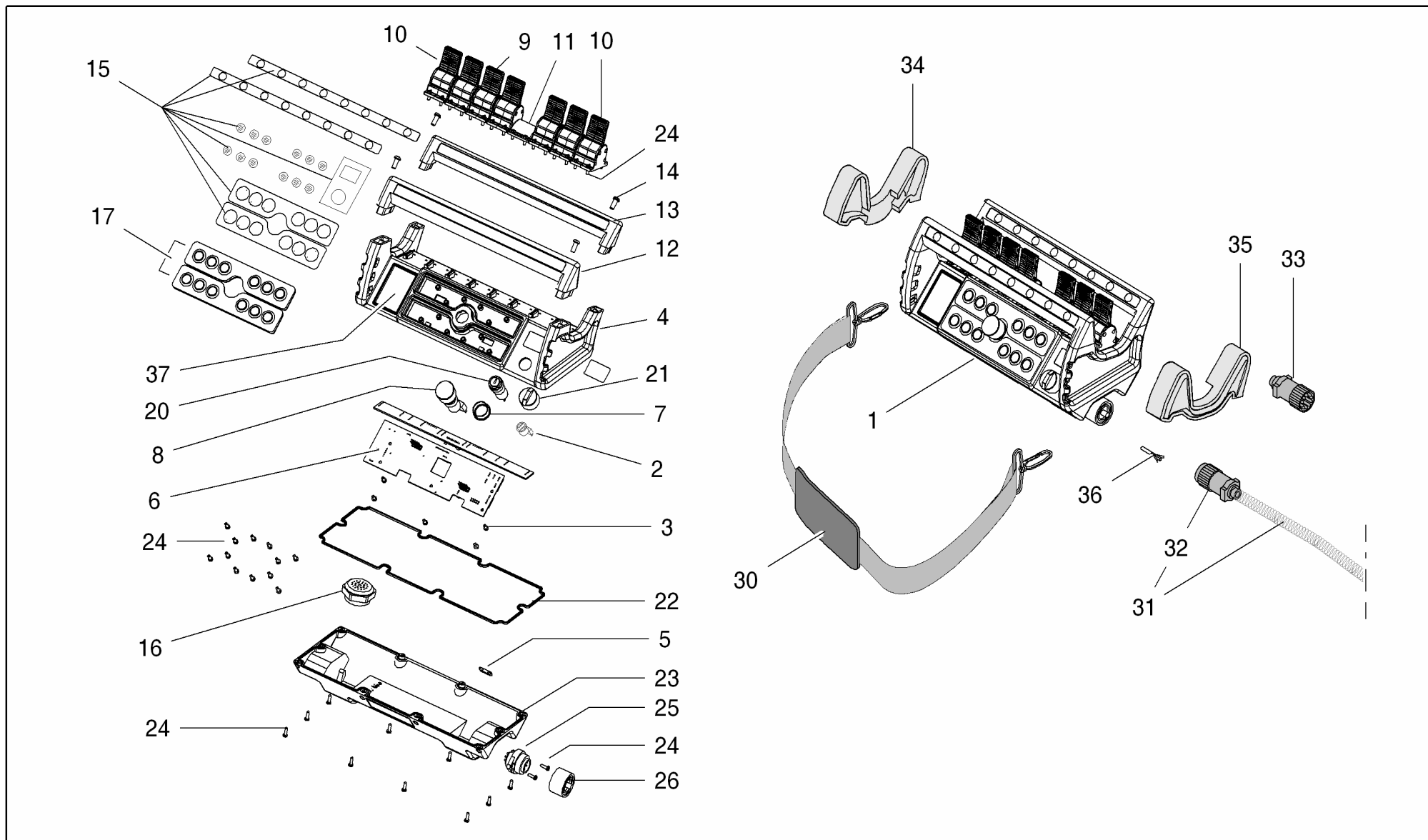

 TÉLÉCOMMANDE



 TELECOMANDO

 FERNSTEUERUNG 
 REMOTE CONTROL

 TELECOMANDO 
 TÉLÉCOMMANDE

POS Codice	Q.tà	 Descrizione	 Description	 Designation	 Benennung	 Descripción
1 26839500	1 NR	telecomando	remote control	télécommande	fernsteuerung	telecomando
1 27237400	1 NR	telecomando case grigio	remote control grey case	télécommande	fernsteuerung	telecomando
2 07359400	1 NR	contatto per stop emergenza telecomando 3s	contact for remote emergency stop 3s	contacter pour remote 3s arret d'urgence	kontakt für remote not 3s	contacto para remotos 3s parada de emergencia
3 2646170003	5 NR	viti scheda elettronica	attachment screw electronic board	vis	schraube	tornillo





 TELECOMANDO

 FERNSTEUERUNG

 REMOTE CONTROL

 TELECOMANDO

 TÉLÉCOMMANDE





POS Codice	Q.tà	 Descrizione	 Description	 Designation	 Benennung	 Descripcìon
4 2646170004	1 NR	coperchio superiore blu telecomando (per ricambio è necessario il sn del telecomando)	upper cover blue remote control (as spare is compulsory the sn of remote control)	couvercle	deckel	tapa
4 2683950001	1 NR	coperchio superiore telecomando case blu solo coperchio, senza componenti e senza display	top cover remote control case blue only case, without components and display	couvercle	deckel	tapa
4 2723740001	1 NR	coperchio superiore telecomando case grigio + display e pulsanti (per ricambio è necessario il sn del telecomando)	top cover remote control case grey + display and buttons (as spare is compulsory the sn of remote control)	couvercle	deckel	tapa
4 2723740002	1 NR	coperchio superiore telecomando case grigio solo coperchio, senza componenti e senza display	top cover remote control case grey only case, without components and display	couvercle	deckel	tapa



 TELECOMANDO

 FERNSTEUERUNG 
 REMOTE CONTROL





 TELECOMANDO 
 TÉLÉCOMMANDE

POS Codice	Q.tà	 Descrizione	 Description	 Designation	 Benennung	 Descripción
5 07359500	1 NR	contatto reed interno telecomando 3s	reed contact internal remote 3s	reed contact intérieur 3s distance	reedkontakt indoor remote 3s	contacto reed 3s remoto de interior
6 2646170002	1 NR	scheda elettronica per telecomando	electronic board for remote control	fiche électrique	elektronische platine	placa electrónica
7 2646170007	1 NR	anello	ring	bague	ring	anillo
8 2646170008	1 NR	pulsante emergenza	emergency button	bouton d'urgence	notstand knopf	pulsador de emergencia
9 17550700	1 NR	kit protezione in gomma per joystick nera	black rubber cover kit for joystick			
9 2646170009	6 NR	leva nera	lever black	levier	hebel	palanca
10 17550800	1 NR	kit protezione in gomma per joystick rossa	red rubber cover kit for joystick			
10 2646170010	2 NR	leva rossa	lever red	levier	hebel	palanca
12 2646170013	1 NR	impugnatura inferiore	grip lower part	poignée	griff	empuñadura
13 2646170012	1 NR	impugnatura superiore	grip upper part	poignée	griff	empuñadura
14 2646170014	4 NR	vite	screw	vis	schraube	tornillo
15 27005200	1 NR	kit adesivi	decals kit	kit collants	aufklebersatz	kit pegatinas

 TELECOMANDO

 FERNSTEUERUNG 
 REMOTE CONTROL





 TELECOMANDO 
 TÉLÉCOMMANDE

POS Codice	Q.tà	 Descrizione	 Description	 Designation	 Benennung	 Descripción
16 2646170027	1 NR	cialino completo di scheda elettronica telecomando	beeper for remote control	vibreur sonore complet de la carte électronique de la télécommande	hupe für fernsteuerung	zumbador completo de tarjeta electrónica telemando
17 2646170017	1 NR	pulsanti	buttons	boutons	druckknopf	botones
20 2683930001	1 NR	interruttore	switch	interrupteur	interruptores	interruptor
21 2683930002	1 NR	chiave accensione	ignition key	clef de démarrage	zündschlüssel	clave de encendido
22 2646170022	1 NR	guarnizione	gasket	joint	dichtung	guarnición
23 2646170023	1 NR	coperchio inferiore	cover lower part	couvercle	deckel	tapa
24 2646170024	56 NR	vite	screw	vis	schraube	tornillo
25 2646170025	1 NR	connettore	connector	connecteur	verbinger	conectador
26 2646170026	1 NR	coperchio connettore	cover connector	couvercle	deckel	tapa
30 2646170030	1 NR	cinghia	belt	courroie	riemen	correa
31 17235800	1 NR	cavo telecomando completo iiis /200	complete remote control cable iiis /200	câble complet télécommande iiis /200	fernbedienungskab el komplett iiis /200	cable telecomando completo iiis /200
32 2646170032	1 NR	connettore collegamento telecomando	connector for remote control	connecteur	verbinger	conectador

 TELECOMANDO

 FERNSTEUERUNG 
 REMOTE CONTROL

 TELECOMANDO 
 TÉLÉCOMMANDE

POS Codice	Q.tà	 Descrizione	 Description	 Designation	 Benennung	 Descripción
33 1684540001	1 NR	dispositivo di comando per abilitazione emergenza a terra	control device for activating the emergency ground	dispositif de commande pour activer le terrain en cas d'urgence	steuervorrichtung für die not-boden	dispositivo de control para activar la planta de emergencia
34 07027200	1 NR	protezione sinistra	left protection	protection gauche	abdeckung links	protección izquierda
35 07027100	1 NR	protezione destra	right protection	protection droits	abdeckung rechts	protección derecha
36 27283000	1 NR	puntalino femmina per connettore telecomando	terminal female connector for remote control	connecteur femelle d'orteil pour la télécommande	toe-buchse für die fernbedienung	conector hembra del dedo del pie para el control remoto
36 2728300001	1 NR	puntalino maschio per connettore telecomando	terminal male connector for remote control	virole connecteur mâle pour la télécommande	zwinge stecker für fernbedienung	férula de conector macho para el control remoto
37 07320200	1 NR	schermo lcd (per ricambio è necessario il sn del telecomando)	display (as spare is compulsory the sn of remote control)	afficher	anzeige	pantalla

AGGIORNATO IL / UPDATED 12/12/2014

**Cod. 17062700 (no a ricambio/no spare kit)**

**KIT ADESIVI PIATTAFORMA AEREA /  
AERIAL PLATFORM KIT STICKERS  
JLG - X23J**

**+ kit in lingua non inclusi nel codice generale e non gestiti a ricambio  
+ language code not included in the standard kit and no spare kit**

**170627IT / 170627GB / 170627FR / 170627DE / 170627ES / 170627NL /  
170627PT / 170627DA / 170627SW / 170627NO**

**DA USARE CON / FOR USE WITH**

**17187700 KIT INTEGRAZIONE ADESIVI PIATTAFORME 3S LITHIUM /  
STICKER KIT INTEGRATION PLATFORM LITHIUM  
X14J - 14J-H - 17J - 17JPLUS - X20JPLUS - X19J - X23J**

---

**• 171877\*\* KIT IN LINGUA / KIT IN LANGUAGE**



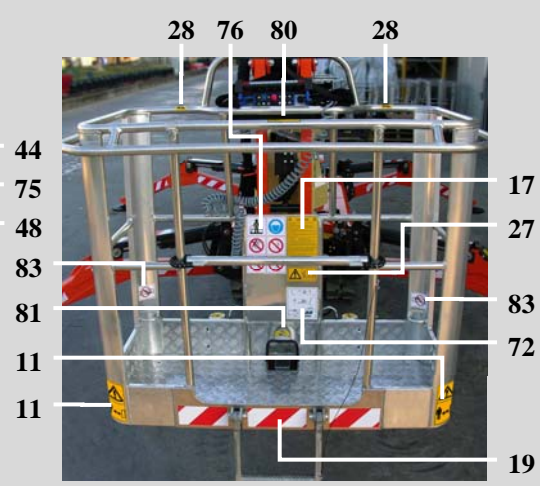
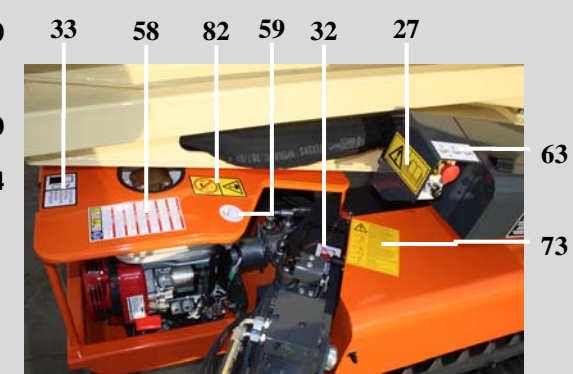
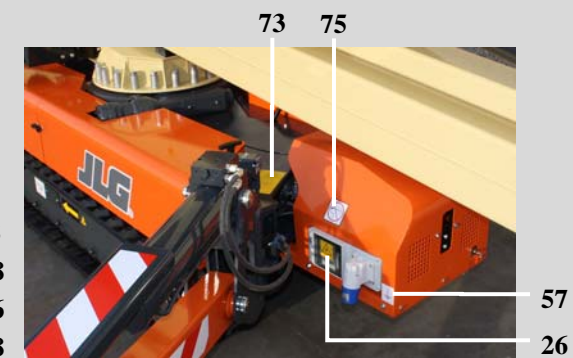
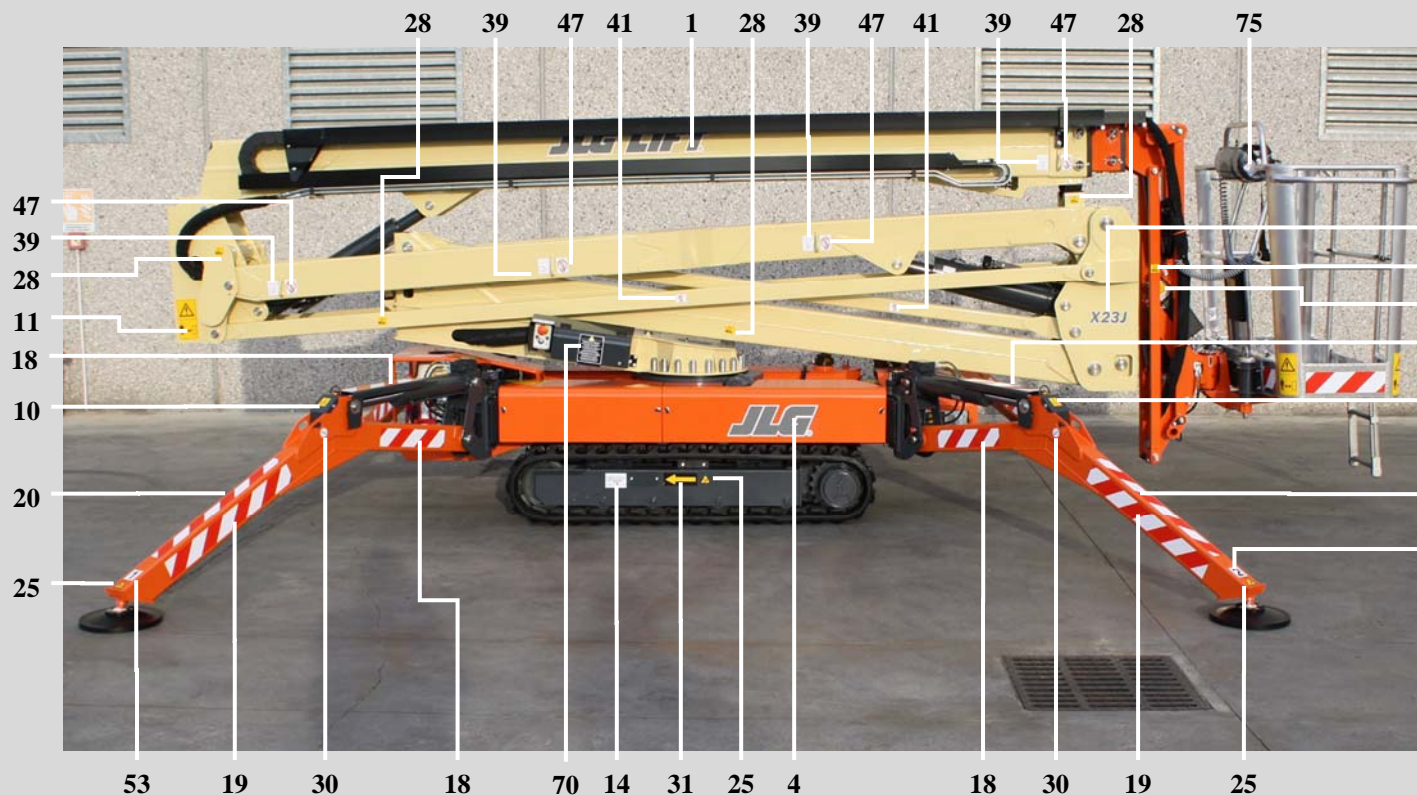

KIT ADESIVI - X23J	AUFKLEBERSATZ - X23J	<b>Cod. 17062700</b>	
SET OF DECALS - X23J	KIT ADHESIVOS - X23J		
KIT COLLANTS - X23J	ADHESIEKIT - X23J	Ed. 12/12/2014	Tav 01

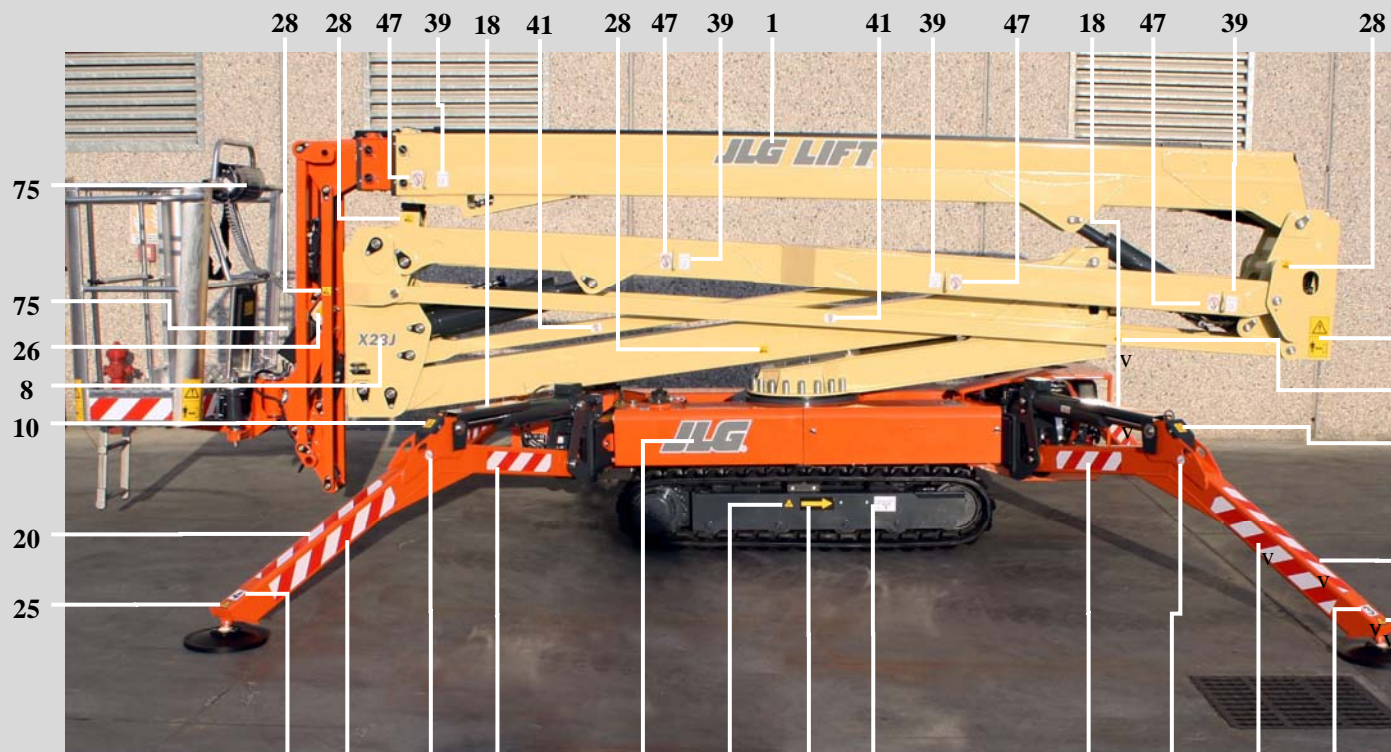

56 19 30 18 4 25 31 14 73 18 30 19 55

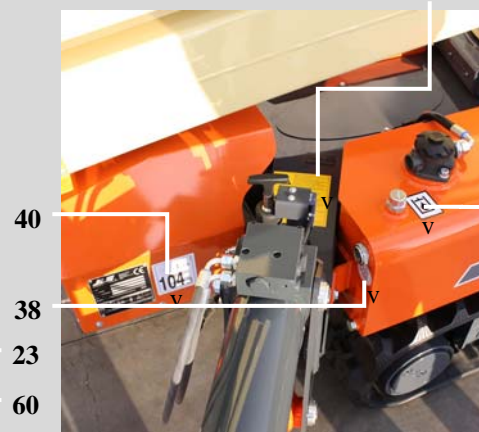
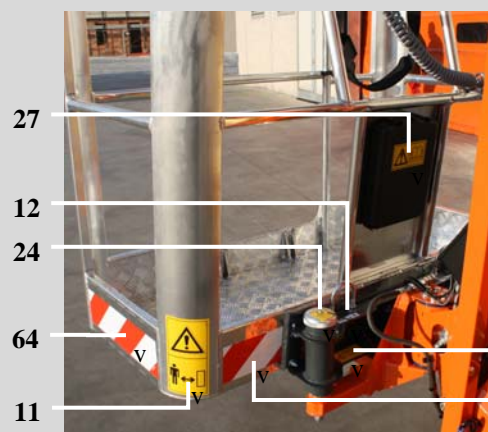
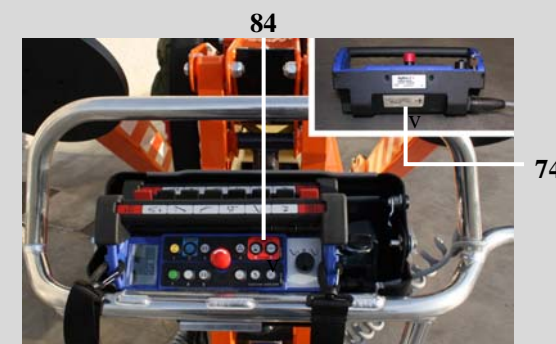

KIT ADESIVI - X23J

SET OF DECALS - X23J

KIT COLLANTS - X23J

AUFKLEBERSATZ - X23J

KIT ADHESIVOS - X23J

ADHESIEKIT - X23J

**Cod. 17062700**

Ed. 12/12/2014

Tav 02



KIT ADESIVI - X23J

SET OF DECALS - X23J

KIT COLLANTS - X23J

AUFKLEBERSATZ - X23J

KIT ADHESIVOS - X23J

ADHESIEKIT - X23J

**Cod. 17062700**

**Ed. 12/12/2014**

**Tav 03**



**Cod. 17062700 (no a ricambio/no spare kit)**

**KIT ADESIVI PIATTAFORMA AEREA /  
*AERIAL PLATFORM KIT STICKERS*  
JLG - X23J**

**17062700 POSIZIONE ADESIVI / POSITION ADHESIVES****IN LINGUA / LANGUAGE****JLG****Aggiornato il / Updated 12/12/2014****VOLTAGGIO / VOLTAGE**

POSIZIONE	CODICE	REV.	DESCRIZIONE	QUANTITA'
01	07060700	A	ADESIVO LOGO JLG LIFT L=809x130 MM	02
02				
03				
04	07060500	A	ADESIVO LOGO JLG L=432x150MM	02
05				
06				
07				02
08	07061300	A	ADESIVO JLG LOGO PIATTAFORMA AEREA CINGOLATA X23J L= 200X64,3 MM	02
09				
10	1646410008	A	ADESIVO PRESSIONE PIEDINO LL 23.12 daN 2100 L=45x50	04
11	06040300	A	ADESIVO PERICOLO MANTENERE LE DISTANZE GIALLO L=100 X 200	06
12	1704277	A	ADESIVO JLG ATTACCO CINTURE DI SICUREZZA L= 76,2X19,05 MM	02
13				
14	1646410007	A	ADESIVO PRESSIONE TOTALE CARRO AL SUOLO LL23.12 L= 100X69	02
15				
16				
17				
18	06039900	A	ADESIVO CON RIGHE BIANCHE ROSSE L= 420 X 80	12
19	06039700	A	ADESIVO CON RIGHE BIANCHE ROSSE L= 700 X 80	09
20	06039600	A	ADESIVO CON RIGHE BIANCHE ROSSE L= 700 X 50	04
21	06527700	A	ADESIVO RIGHE BIANCHE E ROSSE L=255X660	01
22				
23				
24				

## 17062700 POSIZIONE ADESIVI / POSITION ADHESIVES

IN LINGUA / LANGUAGE

JLG

Aggiornato il / Updated 12/12/2014

VOLTAGGIO / VOLTAGE

POSIZIONE	CODICE	REV.	DESCRIZIONE	QUANTITA'
25	06041200	A	ADESIVO SCHIACCIAMENTO PIEDI TRIANGOLARE L=53X46 GIALLO	06
26				
27	06040900	A	ADESIVO LEGGERE IL MANUALE L=125 X 65 GIALLO	03
28	06041300	A	ADESIVO ATTENZIONE PERICOLO TAGLI L=45 X 40 GIALLO	12
29	06056300	A	ADESIVO PERICOLO SCOTTATURE L=60X51 TRIANGOLARE SFONDO GIALLO	01
30	06044000	A	ADESIVO ATTACCO SOLLEVAMENTO SFONDO BIANCO COLORE BLU Ø40	08
31	06040500	A	ADESIVO DIREZ. TRASLAZIONE FRECCIA GIALLA SFONDO NERO L=61 X 160	02
32	1702155	A	ADESIVO JLG STACCABATTERIA L= 63,5X50,80 MM	01
33	1701542	A	ADESIVO JLG CARBURANTE BENZINA L= 101X63,5	01
33	1701505	A	ADESIVO JLG CARBURANTE DIESEL L= 50,8X63,5	01
34				
35	06598400	A	ADESIVO POMPA A MANO LL2312 L=86X34	01
36				
37	1701504	A	ADESIVO JLG OLIO IDRAULICO L=50,8x63,5 MM	01
38	06165000	A	ADESIVO LIVELLO OLIO IDRAULICO Ø50 SFONDO BIANCO	01
39	1703814	A	ADESIVO JLG ATTACCO ANCORAGGIO L=55,56X76,2 MM	08
40	07034200	B	ADESIVO RUMORE 104 dB L=90X100	01
41	07056700	A	ADESIVO JLG DIVIETO DI SOLLEVAMENTO L=54,88X40	04
42				
43				
44	1646410010	C	ADESIVO COMANDI LEVE DISTRIBUTORE PARTE AEREA LL23.12 L=275X50	01
45				
46				
47	1701499	A	ADESIVO JLG DIVIETO DI SOLLEVAMENTO L= 55,56X76 MM	08

**17062700 POSIZIONE ADESIVI / POSITION ADHESIVES****IN LINGUA / LANGUAGE****JLG****Aggiornato il / Updated 12/12/2014****VOLTAGGIO / VOLTAGE**

POSIZIONE	CODICE	REV.	DESCRIZIONE	QUANTITA'
48	06086000	A	ADESIVO SISTEMA BYPASS TRASLAZIONE L=30X50	01
49	06085900	A	ADESIVO SISTEMA BYPASS PARTE AEREA L=30X50	01
50	1646410013	<b>B</b>	ADESIVO PULSANTI DISTRIBUTORE CARRO 3 ELEMENTI L=144 X55 mm	01
51	1646410012	<b>B</b>	ADESIVO PULSANTI DISTRIBUTORE CARRO 4 ELEMENTI L=190X55 mm	01
52				
53	06555500	A	ADESIVO NR 1 L=50X60 BIANCO	01
54	06555600	A	ADESIVO NR 2 L=50X60 BIANCO	01
55	06555700	A	ADESIVO N° 3 L=50X60 BIANCO	01
56	06555800	A	ADESIVO N° 4 L=50X60 BIANCO	01
57	06560500	A	ADESIVO MESSA A TERRA L=40X50	01
58	06232100	A	ADESIVO "ATTENZIONE BENZINA INFIAMMABILE" 7 LINGUE L= 90X171	01
59	06060000	A	ADESIVO LIVELLO OLIO MOTORE Ø50mm	01
60	06040000	A	ADESIVO CON RIGHE BIANCHE ROSSE L= 190 X 100	02
61				
62				
63	06600000	A	ADESIVO SELETTORE A CHIAVE LL23 CON 2°TELECOMANDO	01
64	06086700	A	ADESIVO CON RIGHE BIANCHE E ROSSE L=430X100	02
65	06214200	A	ADESIVO LIQUIDO REFRIGERANTE SFONDO BIANCO Ø 50	01
66				
67	06706500	A	ADESIVO ALLINEAMENTO CESTO (2 PEZZI) L=16X50+13	01
68				
69				
70	07056800	A	ADESIVO JLG DISCESA DI EMERGENZA ALL'INTERNO 7 LINGUE L= 114X130 MM	02
71				

## 17062700 POSIZIONE ADESIVI / POSITION ADHESIVES

IN LINGUA / LANGUAGE

JLG

Aggiornato il / Updated 12/12/2014

VOLTAGGIO / VOLTAGE

POSIZIONE	CODICE	REV.	DESCRIZIONE	QUANTITA'
72	07060000	A	ADESIVO JLG - X23J PORTATA CESTO 2 PERSONE L=135X145 MM	01
72	07440100	A	ADESIVO JLG - X23J PORTATA CESTO 2 PERSONE L=100X145 MM - DA MONTARE SULLE MACCHINE VERSIONE AUSTRALIA X23JA"	01
73	07060400	A	ADESIVO JLG CONTROLLO MICRO STABILIZZATORI L=120x150 MM	04
74	1646410006	A	ADESIVO MANTENERE 1 METRO DI DISTANZA LL23.12 L=75X35	01
75	1001125483	A	ADESIVO JLG VIETATO LAVARE L=63,5X63,5 MM	06
76	06924300	A	ADESIVO CASCO - IMBRAGATURA - DIVIETI SERIE METAL-IIIS L= 170X250 MM	01
77	06919400	A	ADESIVO AVVIAMENTO MOTORE DA TERRA IIIS L=72X35	01
78				
79	1706898	A	ADESIVO JLG EMERGENCY STOP Ø EST.57,15 Ø INT. 30,58	01
80	1706493	B	ADESIVO JLG SCORRIMENTO SBARRA CHIUSURA CESTO L= 76, 2X25,4 MM	01
81	1705828	B	ADESIVO JLG INTERUTTORE PEDALE L= 69,85X54	01
82	1706098	B	ADESIVO JLG PERICOLO ESPLOSIONE L=63,5X117,475 MM	01
83	07050700	A	ADESIVO JLG DIVIETO ATTACCO CINTURE DI SICUREZZA L=76, 2X19,5	02
84	07071000	B	ADESIVO JLG CLAXON SU PIATTAFORME L=38,3X28,55 MM	01
72	07059900	A	ADESIVO JLG - X23J PORTATA CESTO 1 PERSONA L=135X145 MM - non in distinta	01
72	07441500	A	ADESIVO JLG - X23J PORTATA CESTO 1 PERSONA L=100X145 MM - DA MONTARE SULLE MACCHINE VERSIONE AUSTRALIA X23JA" - non in distinta	01

**KIT ADESIVI IN LINGUA /  
*LANGUAGE KIT STICKERS***

**JLG - X23J**

**Cod. (no a ricambio/*no spare kit*)**

**170627IT**

**170627GB**

**170627FR**

**170627DE**

**170627ES**

**170627NL**

**170627PT**

**170627DA**

**170627SW**

**170627NO**

170627** ADESIVI IN LINGUA / ADHESIVES IN LANGUAGE			IN LINGUA / LANGUAGE	JLG
Aggiornato il / Updated 12/12/2014			VOLTAGGIO / VOLTAGE	
POSIZIONE	CODICE	REV.	DESCRIZIONE	QUANTITA'
	170627IT		ADESIVI PIATTAFORMA AEREA CINGOLATA JLG-X23J LINGUA ITALIANO	
17	06555300	B	ADESIVO USO PIATTAFORMA AEREA CINGOLATA - ITALIANO L=128X230 01-09-2008 (*)	01
23	06448100	A	ADESIVO "RIPRISTINARE I TAPPI FERMO GUIDA " ITALIANO L= 90X45	02
24	06448200	A	ADESIVO "SBLOCCARE SOLO NEI CASI PREVISTI" L= 50X50 ITALIANO	02
26	06561200	A	ADESIVO PERICOLO 230 VOLT GIALLO L=47 X 47	04
45	07203200	A	ADESIVO DISCESA DI EMERG. SERIE LL 3S - X14J X19J X23J - ITA L=280X195 MM	01
66	07070200	A	ADESIVO JLG MODO DI SELEZIONE PER PARTE AEREA LL2312 - ITA L=103X40	01
	170627GB		ADESIVI PIATTAFORMA AEREA CINGOLATA JLG-X23J LINGUA INGLESE	
17	06562600	B	ADESIVO USO PIATTAFORMA AEREA CINGOLATA - INGLESE L=128X230 (**)	01
23	06462100	A	ADESIVO "RIPRISTINARE I TAPPI FERMO GUIDA" INGLESE L= 90X45	02
24	06462700	A	ADESIVO "SBLOCCARE SOLO NEI CASI PREVISTI" INGLESE L= 50X50	02
26	06561200	A	ADESIVO PERICOLO 230 VOLT GIALLO L=47 X 47	04
26	06042400	A	ADESIVO PERICOLO 110 VOLT L=47 X 47 GIALLO	04
45	07206200	A	ADESIVO DISCESA DI EMERG. SERIE LL 3S - X14J X19J X23J - ING L=280X195 MM	01
66	07042300	A	ADESIVO JLG MODO DI SELEZIONE PER PARTE AEREA LL2312 - ING L=103X40	01
	170627FR		ADESIVI PIATTAFORMA AEREA CINGOLATA JLG-X23J LINGUA FRANCESE	
17	06562700	B	ADESIVO USO PIATTAFORMA AEREA CINGOLATA - FRANCESE L=128X230 (**)	01
23	06462200	A	ADESIVO "RIPRISTINARE I TAPPI FERMO GUIDA" FRANCESE L= 90X45	02
24	06462800	A	ADESIVO "SBLOCCARE SOLO NEI CASI PREVISTI" FRANCESE L= 50X50	02
26	06561200	A	ADESIVO PERICOLO 230 VOLT GIALLO L=47 X 47	04
45	07206300	A	ADESIVO DISCESA DI EMERG. SERIE LL 3S - X14J X19J X23J - FRA L=280X195 MM	01
66	07070300	A	ADESIVO JLG MODO DI SELEZIONE PER PARTE AEREA LL2312 - FRA L=103X40	01

## 170627\*\* ADESIVI IN LINGUA / ADHESIVES IN LANGUAGE

IN LINGUA / LANGUAGE

JLG

Aggiornato il / Updated 12/12/2014

VOLTAGGIO / VOLTAGE

POSIZIONE	CODICE	REV.	DESCRIZIONE	QUANTITA'
	170627DE		ADESIVI PIATTAFORMA AEREA CINGOLATA JLG-X23J LINGUA TEDESCO	
17	06562800	B	ADESIVO USO PIATTAFORMA AEREA CINGOLATA - TEDESCO L=128X230 (**)	01
23	06462300	A	ADESIVO "RIPRISTINARE I TAPPI FERMO GUIDA" TEDESCO L= 90X45	02
24	06462900	A	ADESIVO "SBLOCCARE SOLO NEI CASI PREVISTI " TEDESCO L= 50X50	02
26	06561200	A	ADESIVO PERICOLO 230 VOLT GIALLO L=47 X 47	04
45	07206400	A	ADESIVO DISC.EMERG. SERIE LL 3S - X14J X19J X23J - TED L=280X195 MM	01
66	07070400	A	ADESIVO JLG MODO DI SELEZIONE PER PARTE AEREA LL2312 - TED L=103X40	01
	170627ES		ADESIVI PIATTAFORMA AEREA CINGOLATA JLG-X23J LINGUA SPAGNOLO	
17	06562900	B	ADESIVO USO PIATTAFORMA AEREA CINGOLATA - SPAGNOLO L=128X230 (**)	01
23	06462400	A	ADESIVO "RIPRISTINARE I TAPPI FERMO GUIDA" SPAGNOLO L= 90X45	02
24	06463000	A	ADESIVO "SBLOCCARE SOLO NEI CASI PREVISTI" SPAGNOLO L= 50X50	02
26	06561200	A	ADESIVO PERICOLO 230 VOLT GIALLO L=47 X 47	04
45	07206500	A	ADESIVO DISCESA DI EMERG. SERIE LL 3S - X14J X19J X23J - SPA L=280X195 MM	01
66	07070500	A	ADESIVO JLG MODO DI SELEZIONE PER PARTE AEREA LL2312 - SPA L=103X40	01
	170627NL		ADESIVI PIATTAFORMA AEREA CINGOLATA JLG-X23J LINGUA OLANDESE	
17	06563000	B	ADESIVO USO PIATTAFORMA AEREA CINGOLATA - OLANDESE L=128X230 (**)	01
23	06462500	A	ADESIVO "RIPRISTINARE I TAPPI FERMO GUIDE" OLANDESE L= 90X45	02
24	06463100	A	ADESIVO "SBLOCCARE SOLO NEI CASI PREVISTI" OLANDESE L= 50X50	02
26	06561200	A	ADESIVO PERICOLO 230 VOLT GIALLO L=47 X 47	04
45	07206600	A	ADESIVO DISCESA DI EMERG. SERIE LL 3S - X14J X19J X23J - OLA L=280X195 MM	01
66	07070600	A	ADESIVO JLG MODO DI SELEZIONE PER PARTE AEREA LL2312 - OLA L=103X40	01



<b>170627** ADESIVI IN LINGUA / ADHESIVES IN LANGUAGE</b>	<b>IN LINGUA / LANGUAGE</b>	<b>JLG</b>
	<b>Aggiornato il / Updated 12/12/2014</b>	<b>VOLTAGGIO / VOLTAGE</b>

POSIZIONE	CODICE	REV.	DESCRIZIONE	QUANTITA'
	170627PT		ADESIVI PIATTAFORMA AEREA CINGOLATA JLG-X23J LINGUA PORTOGHESE	
17	06563100	<b>B</b>	ADESIVO USO PIATTAFORMA AEREA CINGOLATA - PORTOGHESE L=128X230 (**)	01
23	06462600	A	ADESIVO "RIPRISTINARE I TAPPI FERMO GUIDA" PORTOGHESE L= 90X45	02
24	06463200	A	ADESIVO "SBLOCCARE SOLO NEI CASI PREVISTI" PORTOGHESE L= 50X50	02
26	06561200	A	ADESIVO PERICOLO 230 VOLT GIALLO L=47 X 47	04
45	07206700	A	ADESIVO DISCESA DI EMERG. SERIE LL 3S - X14J X19J X23J - POR L=280X195 MM	01
66	07070700	A	ADESIVO JLG MODO DI SELEZIONE PER PARTE AEREA LL2312 - POR L=103X40	01
	170627DA		ADESIVI PIATTAFORMA AEREA CINGOLATA JLG-X23J LINGUA DANESE	
17	07138100	<b>B</b>	ADESIVO USO PIATTAFORMA AEREA CINGOLATA - DANESE L= 128X230 MM	01
23	07137900	A	ADESIVO "RIPRISTINARE I TAPPI FERMO GUIDA" - DANESE L= 90X45 MM	02
24	07138000	A	ADESIVO "SBLOCCARE SOLO NEI CASI PREVISTI" - DANESE L= 50X50 MM	02
26	06561200	A	ADESIVO PERICOLO 230 VOLT GIALLO L=47 X 47	04
45	07206800	<b>B</b>	ADESIVO DISCESA DI EMERG. SERIE LL 3S - X14J X19J X23J - DAN L=280X195 MM	01
66	07138200	A	ADESIVO JLG MODO DI SELEZ. PER PARTE AEREA LL2312 - DANESE L=103X40 MM	01
70	070568DA	A	ADESIVO JLG DISCESA DI EMERGENZA ALL'INTERNO - DANESE L=114X52 MM	02
	170627SW		ADESIVI PIATTAFORMA AEREA CINGOLATA JLG-X23J LINGUA SVEDESE	
17	07137300	<b>B</b>	ADESIVO USO PIATTAFORMA AEREA CINGOLATA - SVEDESE L= 128X230 MM	01
23	07137400	A	ADESIVO "RIPRISTINARE I TAPPI FERMO GUIDA" SVEDESE L= 90X45 MM	02
24	07137500	A	ADESIVO "SBLOCCARE SOLO NEI CASI PREVISTI" SVEDESE" L= 50X50 MM	02
26	06561200	A	ADESIVO PERICOLO 230 VOLT GIALLO L=47 X 47	04
45	07206900	A	ADESIVO DISCESA DI EMERG. SERIE LL 3S - X14J X19J X23J - SVE L=280X195 MM	01
66	07148800	A	ADESIVO JLG MODO DI SELEZIONE PER PARTE AEREA LL2312 - SVE L=103X40 MM	01



AGGIORNATO IL / UPDATED 04/06/2013

**Cod. 17065400 (no a ricambio/no spare kit)**  
**KIT ADESIVI PIATTAFORMA AEREA /**  
***AERIAL PLATFORM KIT STICKERS***  
**JLG - X700AJ**

**+ kit in lingua non incluso nel codice generale e non gestito a ricambio**  
*+kit in language that is not included in the general code and unmanaged parts*

**170654GB**  
**170654FR**  
**170654ES**  
**170654PT**

**DA USARE CON / FOR USE WITH**

- **17107300 KIT ADESIVI INTEGR. PER PIATT. JLG-ANSI LITHIUM\_X390AJ\_X500AJ\_X550AJ\_X700AJ**
- **171073\*\* KIT IN LINGUA**





KIT ADESIVI - X700AJ

SET OF DECALS - X700AJ

KIT COLLANTS - X700AJ

AUFKLEBERSATZ - X700AJ

KIT ADHESIVOS - X700AJ

ADHESIEKIT - X700AJ

**Cod. 17065400**

Ed. 04/06/2013

Tav 01



KIT ADESIVI - X700AJ

SET OF DECALS - X700AJ

KIT COLLANTS - X700AJ

AUFKLEBERSATZ - X700AJ

KIT ADHESIVOS - X700AJ

ADHESIEKIT - X700AJ

**Cod. 17065400**

Ed. 04/06/2013

Tav 02

**Cod. 17065400 (no a ricambio/no spare kit)**

**KIT ADESIVI PIATTAFORMA AEREA /  
*AERIAL PLATFORM KIT STICKERS*  
JLG - X700AJ**

**17065400 POSIZIONE ADESIVI / POSITION STICKERS**  
**JLG - X700AJ**  
**Aggiornato / updated il 04/06/2013**

**IN LINGUA / LANGUAGE**

**JLG**

**VOLTAGGIO / VOLTAGE**

POSIZIONE	CODICE	REV.	DESCRIZIONE	QUANTITA'
01	07060700	A	ADESIVO JLG - LOGO JLG LIFT L=809x130 MM	02
02				
03				
04	07060500	A	ADESIVO JLG - LOGO JLG L=432x150MM	02
05				
06				
07				
08	07062000	A	ADESIVO JLG LOGO PIATTAFORMA AEREA CINGOLATA X700AJ L=200X43,7 MM	02
09				
09				
10	07043500	A	ADESIVO JLG PRESSIONE PIEDINI LL2312 P= 3 Kg/cm2 - 43 psi L= 50x50	04
11				16
12	1704277	A	ADESIVO JLG ATTACCO CINTURE DI SICUREZZA L= 76,2X19,05 MM	02
13				
14	07043400	A	ADESIVO JLG PRESSIONE TOTALE AL SUOLO LL2312 F=3100 kg L= 100x69	02
15				
16				
17				06
18	06039900	A	ADESIVO CON RIGHE BIANCHE ROSSE L= 420 X 80	12
19	06039700	A	ADESIVO CON RIGHE BIANCHE ROSSE L= 700 X 80	09
20	06039600	A	ADESIVO CON RIGHE BIANCHE E ROSSE L=700x50	04
21	06527700	A	ADESIVO RIGHE BIANCHE E ROSSE L=255X660	01
22				
23				01



<b>17065400 POSIZIONE ADESIVI / POSITION STICKERS</b> <b>JLG - X700AJ</b> <b>Aggiornato / updated il 04/06/2013</b>	<b>IN LINGUA / LANGUAGE</b>	<b>JLG</b>
	<b>VOLTAGGIO / VOLTAGE</b>	

POSIZIONE	CODICE	REV.	DESCRIZIONE	QUANTITA'
24				
25				
26				
27	1701640	A	ADESIVO JLG LEGGERE IL MANUALE L= 69,85x69,85 MM	02
28				
29	06056300	A	ADESIVO PERICOLO SCOTTATURE L=60X51 TRIANGOLARE SFONDO GIALLO	01
30	07071200	A	ADESIVO JLG PUNTO DI SOLLEVAMENTO L= 40X66 MM	08
31	06040500	A	ADESIVO DIREZ. TRASLAZIONE FRECCIA GIALLA SFONDO NERO L=61 X 160	02
32	1702155	A	ADESIVO JLG STACCABATTERIA L= 63,5X50,80 MM	01
33	1701542	A	ADESIVO JLG CARBURANTE BENZINA L= 101X63,5	01
33	1701505	A	ADESIVO JLG CARBURANTE DIESEL L= 50,8X63,5	01
34				
35	06598400	A	ADESIVO POMPA A MANO LL2312 L=84X36	01
36				
37	1701504	A	ADESIVO JLG OLIO IDRAULICO L=50,8x63,5 MM	01
38	06165000	A	ADESIVO LIVELLO OLIO IDRAULICO Ø50 SFONDO BIANCO	01
39	1703814	A	ADESIVO JLG ATTACCO ANCORAGGIO ANCORAGGIO L=55,56X76,2 MM	08
40				
41	07056700	A	ADESIVO JLG DIVIETO DI SOLLEVAMENTO L=54,88X40	04
42				
43				
44				01
45				
46				

**17065400 POSIZIONE ADESIVI / POSITION STICKERS****JLG - X700AJ****Aggiornato / updated il 04/06/2013****IN LINGUA / LANGUAGE****JLG****VOLTAGGIO / VOLTAGE**

POSIZIONE	CODICE	REV.	DESCRIZIONE	QUANTITA'
47	1701499	A	ADESIVO JLG DIVIETO DI SOLLEVAMENTO L= 55,56X76 MM	08
48				
49				
50				
51				
52				
53	06555500	A	ADESIVO NR 1 L=50X60	01
54	06555600	A	ADESIVO N° 2 L=50X60	01
55	06555700	A	ADESIVO N° 3 L=50X60	01
56	06555800	A	ADESIVO N° 4 L=50X60	01
57	06560500	A	DISPERSORE MASSA A TERRA	01
58	06232100	A	ADESIVO "ATTENZIONE BENZINA INFIAMMABILE" 7 LINGUE L=90X171	01
59				
60	06040000	A	ADESIVO CON RIGHE BIANCHE ROSSE L= 190 X 100	02
61				
62	06594500	A	ADESIVO SERBATOIO LIQUIDO REFRIGERANTE 70X100 IN 7 LINGUE	01
63	06600000	A	ADESIVO SELETTORE A CHIAVE LL23 CON 2°TELECOMANDO	01
64	06086700	A	ADESIVO RIGHE BIANCHE E ROSSE L=430X100	02
65	06214200	A	ADESIVO LIQUIDO REFRIGERANTE SFONDO BIANCO Ø 50	01
66				
67	06706500	A	ADESIVO ALLINEAMENTO CESTO (2 PEZZI) L=16X50+13	01
68				
69				
70				

**17065400 POSIZIONE ADESIVI / POSITION STICKERS**

**JLG - X700AJ**

**Aggiornato / updated il 04/06/2013**

**IN LINGUA / LANGUAGE**

**JLG**

**VOLTAGGIO / VOLTAGE**

POSIZIONE	CODICE	REV.	DESCRIZIONE	QUANTITA'
71				
72				
73				
74	07043300	A	ADESIVO JLG MANTENE 1 METRO DI DISTANZA LL2312 3S L=75X35	01
75	1001125483	A	ADESIVO JLG VIETATO LAVARE L=63,5X63,5 MM	06
76				
77				
78				
79	1706898	A	ADESIVO JLG EMERGENCY STOP Ø EST.57,15 Ø INT. 30,58	01
80				
81				
82				
83				
84				
85				
86				
87				
88				
89				
90				
91				
91				
92				
93	07050700	A	ADESIVO JLG DIVIETO ATTACCO CINTURE DI SICUREZZA L= 90X67,5 MM	02



**KIT ADESIVI IN LINGUA /  
*LANGUAGEKIT STICKERS***

**JLG - X23J**

**Cod. (no a ricambio/*no spare kit*)**

**170654GB**

**170654FR**

**170654ES**

**170654PT**

170654** ADESIVI IN LINGUA / ADHESIVES IN LANGUAGE JLG - X700AJ Aggiornato / updated il 04/06/2013			IN LINGUA	JLG
			VOLTAGGIO	
POSIZIONE	CODICE	REV.	DESCRIZIONE	QUANTITA'
	170654GB			
11	07056100	A	ADESIVO JLG PERICOLO SCHIACCIAMENTO L= 140x60,71 MM	16
17	1706128	E	ADESIVO JLG PERICOLO FOLGORAZIONE L=120,65x91,50 MM	06
23	07051100	A	ADESIVO JLG PERICOLO CADUTE - RIPRISTINARE I TAPPI L=196,5x35 MM	01
24	07051000	A	ADESIVO JLG ATTENZ.CADUTE - SBLOCCARE SOLO NEI CASI PREVISTI D Ø 60 FORO 4 MM	02
25	07056200	A	ADESIVO JLG ATTACCO SCHIACCIAMENTO ARTO INFERIORE L= 110 x60 MM	08
26	07056300	A	ADESIVO JLG PERICOLO 220V - 50/60HZ L= 75X18,75 MM	03
26	07056400	B	ADESIVO PERICOLO 120 VOLT L=47 X 47 GIALLO	03
44	07045700	B	ADESIVO JLG ANSI DISTRIBUTORE PARTE AEREA X700AJ L=275X50 MM	01
45	07082500	B	ADESIVO JLG ANSI ISTRUZIONI DISCESA DI EMERG. X700AJ L=280 X195MM - GB	01
48	07042200	A	ADESIVO JLG SISTEMA BYPASS TRASLAZIONE L= 30X50	01
49	07042100	A	ADESIVO JLG SISTEMA BYPASS PARTE AEREA L=30X50	01
50	07045900	A	ADESIVO JLG ANSI PULSANTI DISTRIBUTORE CARRO 3 ELEMENTI LL2312 L=144 X55	01
51	07045800	A	ADESIVO JLG ANSI PULSANTI DISTRIBUTORE CARRO 4 ELEMENTI LL2312 L=190X55	01
66	07042300	A	ADESIVO JLG MODO DI SELEZIONE PER PARTE AEREA LL2312 - ING L=103X40	01
71	1702901	A	ADESIVO JLG ISTRUZIONI DISCESA EMERGENZA / POMPA MAUALE L=114,3x58,73MM	01
72	07050300	A	ADESIVO JLG ANSI CARICO MAX IN CESTA L=1963,85x76,2 MM	02
77	07045300	A	ADESIVO JLG ANSI AVVIAMENTO MOTORE DA TERRA IIIS L=72X35	01
80	1706386	A	ADESIVO JLG PERICOLO CADUTE L=196,85x76,2 MM	01
81	1706387	A	ADESIVO JLG PERICOLO SCHIACCIAMENTO L=177,80x69,85 MM	01
82	1706133	C	ADESIVO JLG PERICOLO RIBALTAMENTO L=139,7X68,85 MM	01

<b>170654** ADESIVI IN LINGUA / ADHESIVES IN LANGUAGE</b> <b>JLG - X700AJ</b> <b>Aggiornato / updated il 04/06/2013</b>	<b>IN LINGUA</b>	<b>JLG</b>
	<b>VOLTAGGIO</b>	

POSIZIONE	CODICE	REV.	DESCRIZIONE	QUANTITA'
83	07058700	A	ADESIVO JLG POSIZIONE STABILIZZATORI X700	01
84	1706385	C	ADESIVO JLG SCORRIMENTO SBARRA CHIUSURA CESTO L=184,15X25,4 MM	01
85	07082300	A	ADESIVO JLG USO PIATTAFORMA X700AJ (GB) L=139,70x88,90 MM	01
86	1706099	A	ADESIVO JLG PERICOLO SCHIACCIAMENTO L= 161,925X69,85 MM	01
87	3252347	B	ADESIVO JLG ATTENZIONE PEDALE L= 69,85x57,15 MM	01
88	1702868	B	ADESIVO JLG PERICOLO SCHIACCIAMENTO MANO L= 241,30X25.40 MM	02
89	1703813	A	ADESIVO JLG PERICOLO ESLOSIONE BATTERIE L=149,25X47,62 MM	01
90	1704972	C	ADESIVO JLG PERICOLO ESPLOSIONE L=63,5x92,07 MM	01
91	1702961	A	ADESIVO JLG PERICOLO FUMI DI SCARICO PER CASA L=92,25x44,45 MM -	01
91	1702962	A	ADESIVO JLG PERICOLO FUMI DI SCARICO PER LA CASA L=95,25x44.50 MM	01
92	1705514	A	ADESIVO JLG CONFORMITA' CSA L= 76,20x22,22 MM	01
	170654FR			
	170654ES			
	170654PT			

AGGIORNATO IL / UPDATED 21/11/2014

## **Cod. 17107300 (no a ricambio/no spare kit)**

**KIT INTEGRAZIONE ADESIVI PER PIATTAFORME AEREE LITHIUM-ANSI**

*INTEGRATION KIT STICKERS PLATFORMS LITHIUM-ANSI*

**X390AJ - X500AJ - X550AJ - X600AJ - X700AJ**

**Da usare in aggiunta ai seguenti kit / To be use in addition to the following kits**

**X390AJ - cod.17065200**

**X500AJ - cod.17224100**

**X550AJ - cod.17065300**

**X600AJ - cod. 17485000**

**X700AJ - cod.17065400**

**+ kit in lingua non inclusi nel codice generale e non gestiti a ricambio**

*language code not included in the standard kit and no spare kit*

•  
**+171073GB**

**+ 171073FR**

**+ 171073ES**

**+ 171073PT**







9



16



4



5



KIT ADESIVI - X390AJ

SET OF DECALS - X390AJ

KIT COLLANTS - X390AJ

AUFKLEBERSATZ -X390AJ

KIT ADHESIVOS -X390AJ

ADHESIEKIT -X390AJ

**cod. 17107300**

**Ed. 21/11/2014**

**Tav 01**

9



1



4

17

19

4



13



KIT ADESIVI - X390AJ

SET OF DECALS -X390AJ

KIT COLLANTS -X390AJ

AUFKLEBERSATZ -X390AJ

KIT ADHESIVOS -X390AJ

ADHESIEKIT -X390AJ

**cod. 17107300**

**Ed. 21/11/2014**

**Tav 02**



9



16



4



5



	KIT ADESIVI - X500AJ	AUFKLEBERSATZ - X500AJ	<b>cod. 17107300</b>	
	SET OF DECALS - X500AJ	KIT ADHESIVOS - X500AJ		
	KIT COLLANTS - X500AJ	ADHESIEKIT - X500AJ	Ed. 21/11/2014	Tav 01

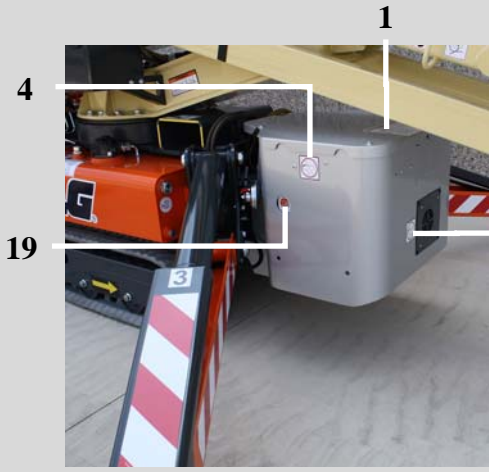
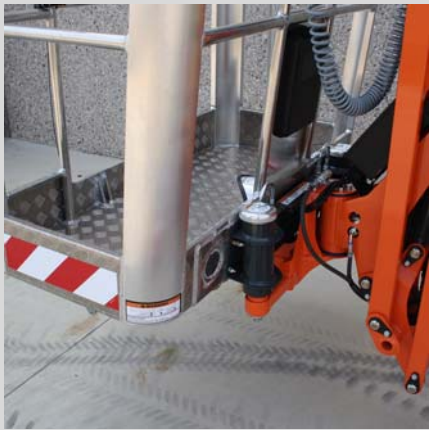

KIT ADESIVI - X500AJ

SET OF DECALS - X500AJ

KIT COLLANTS - X500AJ

AUFKLEBERSATZ - X500AJ

KIT ADHESIVOS - X500AJ

ADHESIEKIT - X500AJ

**cod. 17107300**

**Ed. 21/11/2014**

**Tav 02**



16



9

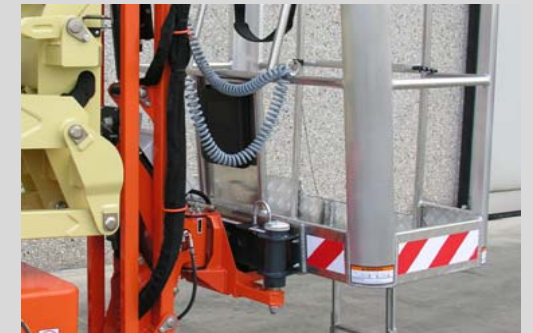

1



4

4

5



KIT ADESIVI - X550AJ

SET OF DECALS - X550AJ

KIT COLLANTS - X550AJ

AUFKLEBERSATZ - X550AJ

KIT ADHESIVOS - X550AJ

ADHESIEKIT - X550AJ

**cod. 17107300**

**Ed. 21/11/2014**

**Tav 01**



4  
17

9



13

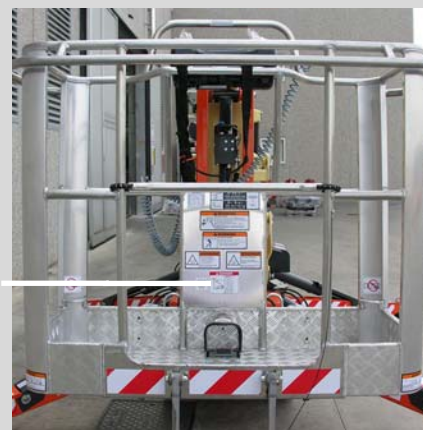

KIT ADESIVI - X550AJ

SET OF DECALS - X550AJ

KIT COLLANTS - X550AJ

AUFKLEBERSATZ - X550AJ

KIT ADHESIVOS - X550AJ

ADHESIEKIT - X550AJ

**cod. 17107300**

Ed. 21/11/2014

Tav 02



4

5



16

9



4



KIT ADESIVI - X600AJ

SET OF DECALS - XX600AJ

KIT COLLANTS - X600AJ

AUFKLEBERSATZ - X600AJ

KIT ADHESIVOS - X600AJ

ADHESIEKIT - X600AJ

**cod. 17107300**

**Ed. 21/11/2014**

**Tav 01**





9

4



13

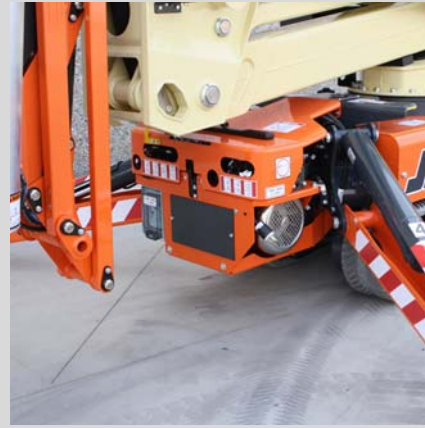

1

18

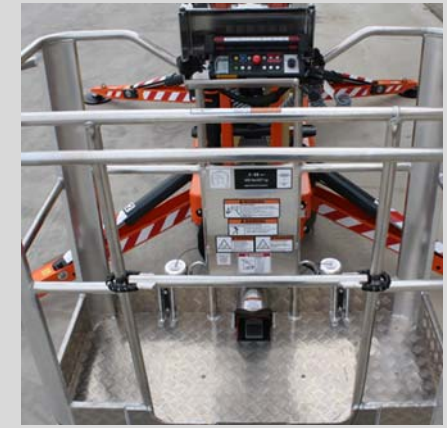

KIT ADESIVI - X600AJ

SET OF DECALS - XX600AJ

KIT COLLANTS - X600AJ

AUFKLEBERSATZ - X600AJ

KIT ADHESIVOS - X600AJ

ADHESIEKIT - X600AJ

**cod. 17107300**

**Ed. 21/11/2014**

**Tav 02**

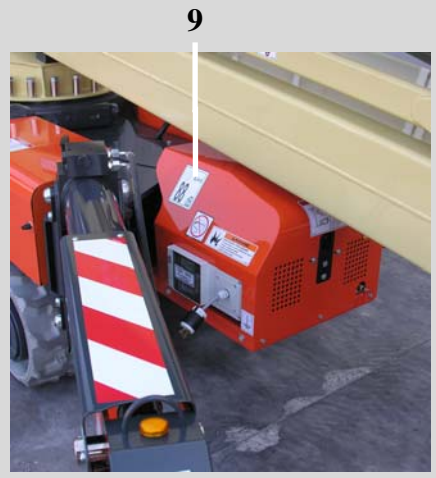
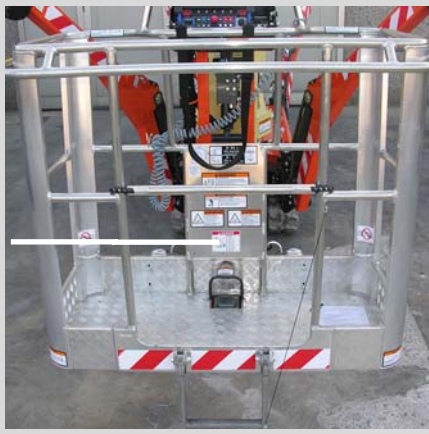

KIT ADESIVI - X700AJ

SET OF DECALS - X700AJ

KIT COLLANTS - X700AJ

AUFKLEBERSATZ - X700AJ

KIT ADHESIVOS -X700AJ

ADHESIEKIT -X700AJ

**cod. 17107300**

**Ed. 21/11/2014**

**Tav 01**

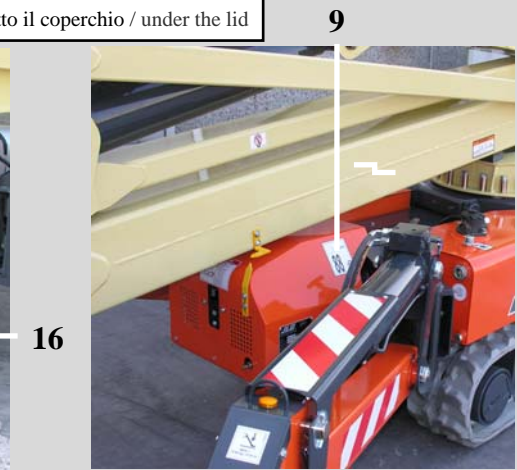
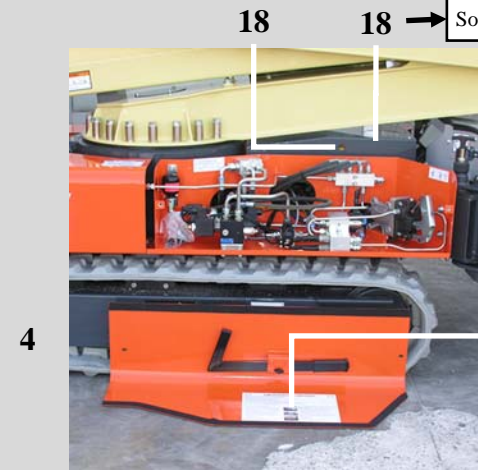

Sotto il coperchio / under the lid

KIT ADESIVI -X700AJ

SET OF DECALS -X700AJ

KIT COLLANTS -X700AJ

AUFKLEBERSATZ -X700AJ

KIT ADHESIVOS -X700AJ

ADHESIEKIT -X700AJ

**cod. 17107300**

Ed. 21/11/2014

Tav 02

**Cod. 17107300 (no a ricambio/no spare kit)**

**KIT INTEGRAZIONE ADESIVI PIATTAFORME AEREE LITHIUM-ANSI**  
*INTEGRATION KIT STICKERS PLATFORMS LITHIUM-ANSI*  
**X390AJ - X500AJ - X550AJ - X600AJ - X700AJ**

**Da usare in aggiunta ai seguenti kit / To be use in addition to the following kits**

**X390AJ - cod.17065200**

**X500AJ - cod.17224100**

**X550AJ - cod.17065300**

**X600AJ - cod. 17485000**

**X700AJ - cod.17065400**

**17107300 POSIZIONE ADESIVI /**  
**POSITION STICKERS**  
**Aggiornato il / Updated on 21/11/2014**

**IN LINGUA / LANGUAGE**

**JLG**

**VOLTAGGIO / VOLTAGE**

POS.	COD.	REV.	DESCRIZIONE / DESCRIPTION	Q.tà
01				
02				
03				
04	1001125483	A	ADESIVO JLG VIETATO LAVARE L=63,5X63,5 MM	03
05	06506400	<b>B</b>	ADESIVO " CHIAVE DI ACCENSIONE" ESTERNO Ø 49 FORO Ø 22 SERIE LITHIUM ION	01
06				
07				
08				
09	06520600	<b>B</b>	ADESIVO RUMORE 88 dB L=90x100	02
10				
11				
12				
13				
14				
15				
16				
17	07264700	A	ADESIVO IND. LED CARICABATT. 48V (Ø EST.31MM Ø INT.6 MM) VECCHIO BMS (FINO A C170000329)	01
18	07264800	A	ADESIVO INDICATORE LED RICARICA BATTERIE Ø EST.21MM Ø INT.4 MM ( X600AJ - X700AJ)	02
19	07394800	A	ADESIVO IND. LED CARICABATT. 48V (Ø EST.31MM Ø INT.6 MM) NUOVO BMS/4 (DA C170000330)	01
20				
21				
22				

**KIT ADESIVI IN LINGUA PER /  
LANGUAGE KIT STICKERS FOR  
X390AJ - X500AJ - X550AJ - X600AJ - X700AJ**

**Cod. (no a ricambio/*no spare kit*)**

**+ 171073GB**

**+ 171073FR**

**+ 171073ES**

**+ 171073PT**

**171073\*\* POSIZIONE ADESIVI IN LINGUA /**  
**POSITION LANGUAGE STICKERS**  
**Aggiornato il / Updated on 21/11/2014**

**IN LINGUA / LANGUAGE**

**JLG**

**VOLTAGGIO / VOLTAGE**

POS.	COD.	REV.	DESCRIZIONE / DESCRIPTION	Q.tà
	171073GB		ADESIVI PIATTAF. AEREA X390AJ - X14J - X17J - X550AJ - X19J - X700AJ - X23J - LINGUA INGLESE	
01	07107200	A	ADESIVO JLG-ANSI ATTENZIONE PERICOLO BATTERIE - ING L=210X145 MM	01
07				
10				
11				
12				
13	07107100	A	ADESIVO JL-ANSI RICARICARE LE BATTERIE DOPO L'USO ALMENO OGNI 3 MESI - ING L=50x50 MM	01
14				
15				01
16	07110300	A	ADESIVO JLG ANSI ISTRUZIONI DISCESA DI EMERG. X390AJ LITHIUM - ING L=280 X195MM	01
16	-----	A	ADESIVO JLG ANSI ISTRUZ. DISCESA DI EMERG. X500AJ / Utilizzare l' adesivo della motorizzazione con motore termico - vedere kit lingua inglese cod. 172241GB -Use the thermal sticker version - see the En-	01
16	07110200	A	ADESIVO JLG ANSI ISTRUZIONI DISCESA DI EMERG. X550AJ LITHIUM L=280 X195MM - GB	01
16	-----	A	ADESIVO JLG ANSI ISTRUZ. DISCESA DI EMERG. X600AJ / Utilizzare l' adesivo della motorizzazione con motore termico - vedere kit lingua inglese cod. 174850GB - Use the thermal sticker version - see the English language kit cod. 172241GB	01
16	07110100	A	ADESIVO JLG ANSI ISTRUZIONI DISCESA DI EMERG. X700AJ LITHIUM - ING L=280 X195MM	01









**Cod. 17187700 (no a ricambio/no spare kit)**

**KIT INTEGRAZIONE ADESIVI PER PIATTAFORME AEREE LITHIUM-CE /  
*INTEGRATION KIT STICKERS PLATFORMS LITHIUM-CE***

**X14J - X14J-H - X17J - X17JPLUS - X19J - X20JPLUS - X23J**

*Da usare in aggiunta a / To use in added to*

**X14J - cod.17063500 / X14J-H - cod.17065000 / X17J cod.17063700 / X17JPLUS cod. 17242800 /  
X19J cod.17063200 / X20JPLUS cod. 17351800 / X23J cod.17062700**

**+ kit in lingua non inclusi nel codice generale e non gestiti a ricambio**

**+ *language code not included in the standard kit and no spare kit***

**+171877IT + 171877GB + 171877FR + 171877DE + 171877ES + 171877NL**

**+ 171877PT + 171877SW + 171877DA + 171877NO + 171877JA**





16



KIT ADESIVI - X14J

SET OF DECALS - X14J

KIT COLLANTS - X14J

AUFKLEBERSATZ - X14J

KIT ADHESIVOS - X14J

ADHESIEKIT - X14J

**cod. 17187700**

Ed. 02/05/2013

Tav 01

9



1



4  
17

4



13



KIT ADESIVI - X14J

SET OF DECALS - X14J

KIT COLLANTS - X14J

AUFKLEBERSATZ - X14J

KIT ADHESIVOS - X14J

ADHESIEKIT - X14J

**cod. 17187700**

Ed. 02/05/2013

Tav 02



16

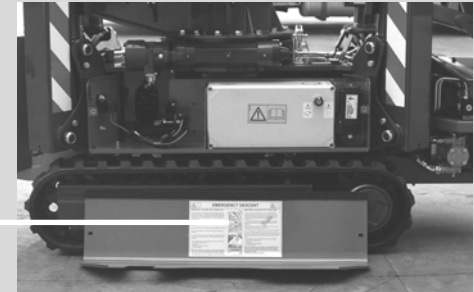

4



5



KIT ADESIVI - X17J

SET OF DECALS - X17J

KIT COLLANTS - X17J

AUFKLEBERSATZ - X17J

KIT ADHESIVOS - X17J

ADHESIEKIT - X17J

**cod. 17187700**

Ed. 02/05/2013

Tav 01



13

1



4

17

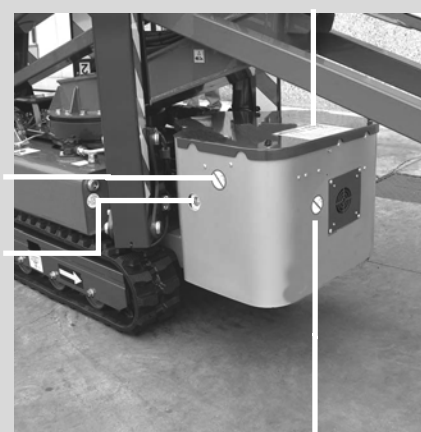

4



KIT ADESIVI - X17J

SET OF DECALS - X17J

KIT COLLANTS - X17J

AUFKLEBERSATZ - X17J

KIT ADHESIVOS - X17J

ADHESIEKIT - X17J

**cod. 17187700**

Ed. 02/05/2013

Tav 02





9



16



1

4

4



5



KIT ADESIVI - X17JPLUS

SET OF DECALS - X17JPLUS

KIT COLLANTS - X17JPLUS

AUFKLEBERSATZ - X17JPLUS

KIT ADHESIVOS - X17JPLUS

ADHESIEKIT - X17JPLUS

**cod. 17187700**

Ed. 02/05/2013

Tav 01



9



13



4

17



3



KIT ADESIVI - X17JPLUS

SET OF DECALS - X17JPLUS

KIT COLLANTS - X17JPLUS

AUFKLEBERSATZ - X17JPLUS

KIT ADHESIVOS - X17JPLUS

ADHESIEKIT - X17JPLUS

**cod. 17187700**

Ed. 02/05/2013

Tav 02

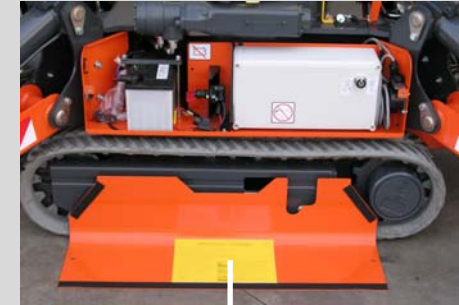

16



9



5



KIT ADESIVI - X19J

SET OF DECALS - X19J

KIT COLLANTS - X19J

AUFKLEBERSATZ - X19J

KIT ADHESIVOS - X19J

ADHESIEKIT - X19J

**cod. 17187700**

Ed. 02/05/2013

Tav 01



9

4

17



13



KIT ADESIVI - X19J

SET OF DECALS - X19J

KIT COLLANTS - X19J

AUFKLEBERSATZ - X19J

KIT ADHESIVOS - X19J

ADHESIEKIT - X19J

**cod. 17187700**

Ed. 02/05/2013

Tav 02



9



16



5



KIT ADESIVI - X20JPLUS

SET OF DECALS - X20JPLUS

KIT COLLANTS - X20JPLUS

AUFKLEBERSATZ - X20JPLUS

KIT ADHESIVOS - X20JPLUS

ADHESIEKIT - X20JPLUS

**cod. 17187700**

Ed. 02/05/2013

Tav 01



9



13



4

17



3



KIT ADESIVI - X20JPLUS

SET OF DECALS - X20JPLUS

KIT COLLANTS - X20JPLUS

AUFKLEBERSATZ - X20JPLUS

KIT ADHESIVOS - X20JPLUS

ADHESIEKIT - X20JPLUS

**cod. 17187700**

Ed. 02/05/2013

Tav 02



5

9

4

13

KIT ADESIVI - X23J

SET OF DECALS - X23J

KIT COLLANTS - X23J

AUFKLEBERSATZ - X23J

KIT ADHESIVOS - X23J

ADHESIEKIT - X23J

**cod. 17187700**

**Ed. 02/05/2013**

**Tav 01**

Sotto il carter / Under the hood

18

4



18



1

16



4



9



KIT ADESIVI - X23J

SET OF DECALS - X23J

KIT COLLANTS - X23J

AUFKLEBERSATZ - X23J

KIT ADHESIVOS - X23J

ADHESIEKIT - X23J

**cod. 17187700**

Ed. 02/05/2013

Tav 02



**Cod. 17187700** (*no a ricambio/no spare kit*)

**KIT INTEGRAZIONE ADESIVI PER PIATTAFORME AEREE LITHIUM-CE**  
***INTEGRATION KIT STICKERS PLATFORMS LITHIUM-CE***  
**X14J - X14J-H - X17J - X17JPLUS - X19J - X23J**

**17187700 POSIZIONE ADESIVI 7 LINGUE /  
POSITION LANGUAGE STICKERS**  
Aggiornato il / Updated 02/05/2013

**IN LINGUA / LANGUAGE**

**JLG**

**VOLTAGGIO / VOLTAGE**

POS.	COD.	REV.	DESCRIZIONE / DESCRIPTION	Q.tà
	17187700		KIT INTEGRAZIONE ADESIVI PER PIATTAFORME AEREE CE LITHIUM X14J - X14J-H - X17J - -X19J -	
01				
02				
03				
04	1001125483	A	ADESIVO JLG VIETATO LAVARE L=63,5X63,5 MM	03
05	06506400	B	ADESIVO " CHIAVE DI ACCENSIONE" ESTERNO Ø 49 FORO Ø 22 SERIE LITHIUM ION	01
06				
07				
08				02
09	06520600	B	ADESIVO RUMORE 88 dB L=90x100	02
10				
11				
12				
13				
14				
15				
16				
17	07264700	A	ADESIVO INDICATORE LED CARICABATTERIE 48V (Ø EST.31MM Ø INT.6 MM) VECCHIO BMS (FINO A C170000329)	01
	07394800	A	ADESIVO INDICATORE LED CARICABATTERIE 48V (Ø EST.31MM Ø INT.6 MM) NUOVO BMS/4 (DA C170000330)	01
18	07264800	A	ADESIVO INDICATORE LED RICARICA BATTERIE Ø EST.21MM Ø INT.4 MM	02

**KIT ADESIVI IN LINGUA PER /  
LANGUAGE KIT STICKERS FOR  
X14J - X14J-H - X17J - X17JPLUS - X19J - X20JPLUS - X23J**

***Cod. (no a ricambio/no spare kit)***

**- 171877IT + 171877GB + 171877FR + 171877DE + 171877ES  
+ 171877NL + 171877PT + 171877SW + 171877DA + 171877NO  
+ 171877JA**

**171877\*\* POSIZIONE ADESIVI IN LINGUA /  
POSITION LANGUAGE STICKERS**  
Aggiornato il / Updated 02/05/2013

**IN LINGUA / LANGUAGE**

**JLG**

**VOLTAGGIO / VOLTAGE**

POS.	COD.	REV.	DESCRIZIONE / DESCRIPTION	Q.tà
	171877IT		KIT ADESIVI INTEGR. PIATT. AEREA X14J-H- X14J - X17J - X19J X23J LITHIUM - LINGUA ITALIANO	
01	07188700	A	ADESIVO JLG ATTENZIONE PERICOLO BATTERIE - ITA L=210X145 MM	01
07				
10				
11				
12				
13	07188100	A	ADESIVO JLG RICARICARE LE BATTERIE DOPO L'USO O ALMENO OGNI 3 MESI L=50x50 MM – ITA	01
14				
16 solo X14J-H	1693870003	B	ADESIVO ISTRUZIONI DISCESA EMERGENZA GL1470LI ITALIANO GIALLO L=290x175 MM (**)	01
16 solo X17J	1705720001	A	ADESIVO ISTRUZIONI DISCESA DI EMERGENZA GL14703S LITHIUM ITALIANO L=290X175 MM (**)	01
16			<b>Per le / for X14J - X17JPLUS - X19J - X20JPLUS - X23J Vedere discesa di emergenza motore termico / See emergency lowering heat engine</b>	
	171877GB		KIT ADESIVI INTEGR. PIATT. AEREA X14J-H- X14J - X17J - X19J X23J LITHIUM - LINGUA INGLESE	
01	07201700	A	ADESIVO JLG ATTENZIONE PERICOLO BATTERIE - ING L=210X145 MM	01
07				
10				
11				
12				
13	07202100	A	ADESIVO JLG RICARICARE LE BATTERIE DOPO L'USO O ALMENO OGNI 3 MESI L=50x50 MM -ING	01
14				
16 per X14J-H	1693870004	B	ADESIVO ISTRUZIONI DISCESA EMERGENZA GL1470LI INGLESE GIALLO L=290x175 MM	01
16 per X17J	1705720002	A	ADESIVO ISTRUZIONI DISCESA DI EMERGENZA GL14703S LITHIUM INGLESE L=290X175 MM	01
16			<b>Per le / for X14J - X17JPLUS - X19J - X20JPLUS - X23J Vedere discesa di emergenza motore termico / See emergency lowering heat engine</b>	

**171877\*\* POSIZIONE ADESIVI IN LINGUA /  
POSITION LANGUAGE STICKERS**  
Aggiornato il / Updated 02/05/2013

**IN LINGUA / LANGUAGE**

**JLG**

**VOLTAGGIO / VOLTAGE**

POS.	COD.	REV.	DESCRIZIONE / DESCRIPTION	Q.tà
	171877FR		KIT ADESIVI INTEGR. PIATT. AEREA X14J-H- X14J - X17J - X19J X23J LITHIUM - LINGUA FRANCESE	
01	07201800	A	ADESIVO JLG ADESIVO ATTENZIONE PERICOLO BATTERIE - FRA L=210X145 MM	01
07				
10				
11				
12				
13	07202200	A	ADESIVO JLG RICARICARE LE BATTERIE DOPO L'USO ALMENO OGNI 3 MESI - FRA L=50x50 MM	01
14				
16 per X14J-H	1693870005	B	ADESIVO ISTRUZIONI DISCESA EMERGENZA GL1470LI FRANCESE GIALLO L=290x175 MM (**)	01
16 per X17J	1705720003	A	ADESIVO ISTRUZIONI DISCESA DI EMERGENZA GL14703S LITHIUM FRANCESE L=290X175 MM (**)	01
16	/	/	<b>Per le / for X14J - X17JPLUS - X19J - X20JPLUS - X23J Vedere discesa di emergenza motore termico / See emergency lowering heat engine</b>	01
	171877DE		KIT ADESIVI INTEGR. PIATT. AEREA X14J-H- X14J - X17J - X19J X23J LITHIUM - LINGUA TEDESCO	
01	07188800	A	ADESIVO JLG ATTENZIONE PERICOLO BATTERIE - TED L=210X145 MM	01
07				
10				
11				
12				
13	07188200	A	ADESIVO JLG RICARICARE LE BATTERIE DOPO L'USO O ALMENO OGNI 3 MESI L=50x50 MM –TED	01
14				
16 per X14J-H	1693870006	B	ADESIVO ISTRUZIONI DISCESA EMERGENZA GL1470LI TEDESCO GIALLO L=290x175 MM (**)	01
16 per X17J	1705720004	A	ADESIVO ISTRUZIONI DISCESA DI EMERGENZA GL14703S LITHIUM TEDESCO L=290X175 MM (**)	01
16	/	/	<b>Per le / for X14J - X17JPLUS - X19J - X20JPLUS - X23J Vedere discesa di emergenza motore termico / See emergency lowering heat engine</b>	01

**171877\*\* POSIZIONE ADESIVI IN LINGUA /  
POSITION LANGUAGE STICKERS**  
Aggiornato il / Updated 02/05/2013

**IN LINGUA / LANGUAGE**

**JLG**

**VOLTAGGIO / VOLTAGE**

POS.	COD.	REV.	DESCRIZIONE / DESCRIPTION	Q.tà
	171877ES		KIT ADESIVI INTEGR. PIATT. AEREA X14J-H- X14J - X17J - X19J X23J LITHIUM - LINGUA SPAGNOLO	
01	07201900	A	ADESIVO JLG ATTENZIONE PERICOLO BATTERIE - SPA L=210X145 MM -	01
07				
10				
11				
12				
13	07202300	A	ADESIVO JLG RICARICARE LE BATTERIE DOPO L'USO ALMENO OGNI 3 MESI - SPA L=50x50 MM	01
14				
16 per X14J-H	1693870007	B	ADESIVO ISTRUZIONI DISCESA EMERGENZA GL1470LI SPAGNOLO GIALLO L=290x175 (**)	01
16 per X17J	1705720005	A	ADESIVO ISTRUZIONI DISCESA DI EMERGENZA GL14703S LITHIUM SPAGNOLO L=290X175 MM (**)	01
16			<b>Per le / for X14J - X17JPLUS - X19J - X20JPLUS - X23J Vedere discesa di emergenza motore termico / See emergency lowering heat engine</b>	
	171877NL		KIT ADESIVI INTEGR. PIATT. AEREA X14J-H- X14J - X17J - X19J X23J LITHIUM - LINGUA OLANDESE	
01	07188900	A	ADESIVO JLG ATTENZIONE PERICOLO BATTERIE - OLA L=210X145 MM	01
07				
10				
11				
12				
13	07188300	A	ADESIVO JLG RICARICARE LE BATTERIE DOPO L'USO O ALMENO OGNI 3 MESI L=50x50 MM – OLA	01
14				
16 per X14J-H	1693870008	B	ADESIVO ISTRUZIONI DISCESA EMERGENZA GL1470LI OLANDESE GIALLO L=290x175 MM (**)	01
16 per X17J	1705720006	A	ADESIVO ISTRUZIONI DISCESA DI EMERGENZA GL14703S LITHIUM OLANDESE L=290X175 MM (**)	01
16			<b>Per le / for X14J - X17JPLUS - X19J - X20JPLUS - X23J Vedere discesa di emergenza motore termico / See emergency lowering heat engine</b>	01

**171877\*\* POSIZIONE ADESIVI IN LINGUA /  
POSITION LANGUAGE STICKERS**  
Aggiornato il / Updated 02/05/2013

**IN LINGUA / LANGUAGE**

**JLG**

**VOLTAGGIO / VOLTAGE**

POS.	COD.	REV.	DESCRIZIONE / DESCRIPTION	Q.tà
	171877PT		KIT ADESIVI INTEGR. PIATT. AEREA X14J-H-X14J-X17J-X19J-X23J LITHIUM - LINGUA PORTOGHESE	
01	07202000	A	ADESIVO JLG ATTENZIONE PERICOLO BATTERIE - POR L=210X145 MM	01
07				
10				
11				
12				
13	07202400	A	ADESIVO JLG RICARICARE LE BATTERIE DOPO L'USO O ALMENO OGNI 3 MESI L=50x50 MM – POR	01
14				
16 per X14J-H	1693870009	B	ADESIVO ISTRUZIONI DISCESA EMERGENZA GL1470LI PORTOGHESE GIALLO L=290x175 MM (**)	01
16 per X17J	1705720007	A	ADESIVO ISTRUZ. DISCESA DI EMERGENZA GL14703S LITHIUM PORTOGHESE L=290X175 MM (**)	01
16			<b>Per le / for X14J - X17JPLUS - X19J - X20JPLUS - X23J Vedere discesa di emergenza motore termico / See emergency lowering heat engine</b>	
	171877SW		KIT ADESIVI INTEGR. PIATT. AEREA X14J-H-X14J-X17J-X19J-X23J LITHIUM - SVEDESE	
01	07189000	A	ADESIVO JLG ATTENZIONE PERICOLO BATTERIE - SVE L=210X145 MM	01
07				
10				
11				
12				
13	07188400	A	ADESIVO JLG RICARICARE LE BATTERIE DOPO L'USO O ALMENO OGNI 3 MESI L=50x50 MM – SVE	01
14				
16 per X14J-H	1693870010	A	ADESIVO ISTRUZIONI DISCESA EMERGENZA GL1470LI SVEDESE GIALLO L=290x175 MM (**)	01
16 per X17J	1705720010	A	ADESIVO ISTRUZ. DISCESA DI EMERGENZA GL14703S LITHIUM SVEDESE L=290X175 MM (**)	01
16			<b>Per le / for X14J - X17JPLUS - X19J - X20JPLUS - X23J Vedere discesa di emergenza motore termico / See emergency lowering heat engine</b>	

**171877\*\* POSIZIONE ADESIVI IN LINGUA /  
POSITION LANGUAGE STICKERS**  
Aggiornato il / Updated 02/05/2013

**IN LINGUA / LANGUAGE**

**JLG**

**VOLTAGGIO / VOLTAGE**

POS.	COD.	REV.	DESCRIZIONE / DESCRIPTION	Q.tà
	171877DA		KIT ADESIVI INTEGR. PIATT. AEREA X14J-H-X14J-X17J-X19J-X23J LITHIUM - LINGUA DANESE	
01	07189100	A	ADESIVO JLG ATTENZIONE PERICOLO BATTERIE - DAN L=210X145 MM	01
07				
10				
11				
12				
13	07188500	A	ADESIVO JLG RICARICARE LE BATTERIE DOPO L'USO O ALMENO OGNI 3 MESI L=50x50 MM – DAN	01
14				
16 per X14J-H	1693870011	A	ADESIVO ISTRUZIONI DISCESA EMERGENZA GL1470LI SVEDESE DANESE L=290x175 MM (**)	01
16 per X17J	1705720011	A	ADESIVO ISTRUZ. DISCESA DI EMERGENZA GL14703S LITHIUM DANESE L=290X175 MM (**)	01
16			<b>Per le / for X14J - X17JPLUS - X19J - X20JPLUS - X23J Vedere discesa di emergenza motore termico / See emergency lowering heat engine</b>	
	171877NO		KIT ADESIVI INTEGR. PIATT. AEREA X14J-H-X14J-X17J-X19J-X23J LITHIUM - LINGUA NORVEGESE	
01	07189200	A	ADESIVO JLG ATTENZIONE PERICOLO BATTERIE - NOR L=210X145 MM	01
07				
10				
11				
12				
13	07188600	A	ADESIVO JLG RICARICARE LE BATTERIE DOPO L'USO O ALMENO OGNI 3 MESI L=50x50 MM – NOR	01
14				
16 per X14J-H	1693870012	A	ADESIVO ISTRUZIONI DISCESA EMERGENZA GL1470LI NORVEGESE GIALLO L=290x175 MM (**)	01
16 per X17J	1705720012	A	ADESIVO ISTRUZ. DISCESA DI EMERGENZA GL14703S LITHIUM NORVEGESE L=290X175 MM (**)	01
16	/	/	<b>Per le / for X14J - X17JPLUS - X19J - X20JPLUS - X23J Vedere discesa di emergenza motore termico / See emergency lowering heat engine</b>	





# TABELLA PERNI/SPINE (PINS TABLE)

LOCKING SYSTEM  
GHIERA  
(LOCKNUTS CODE)  
REF. TABLE BELOW

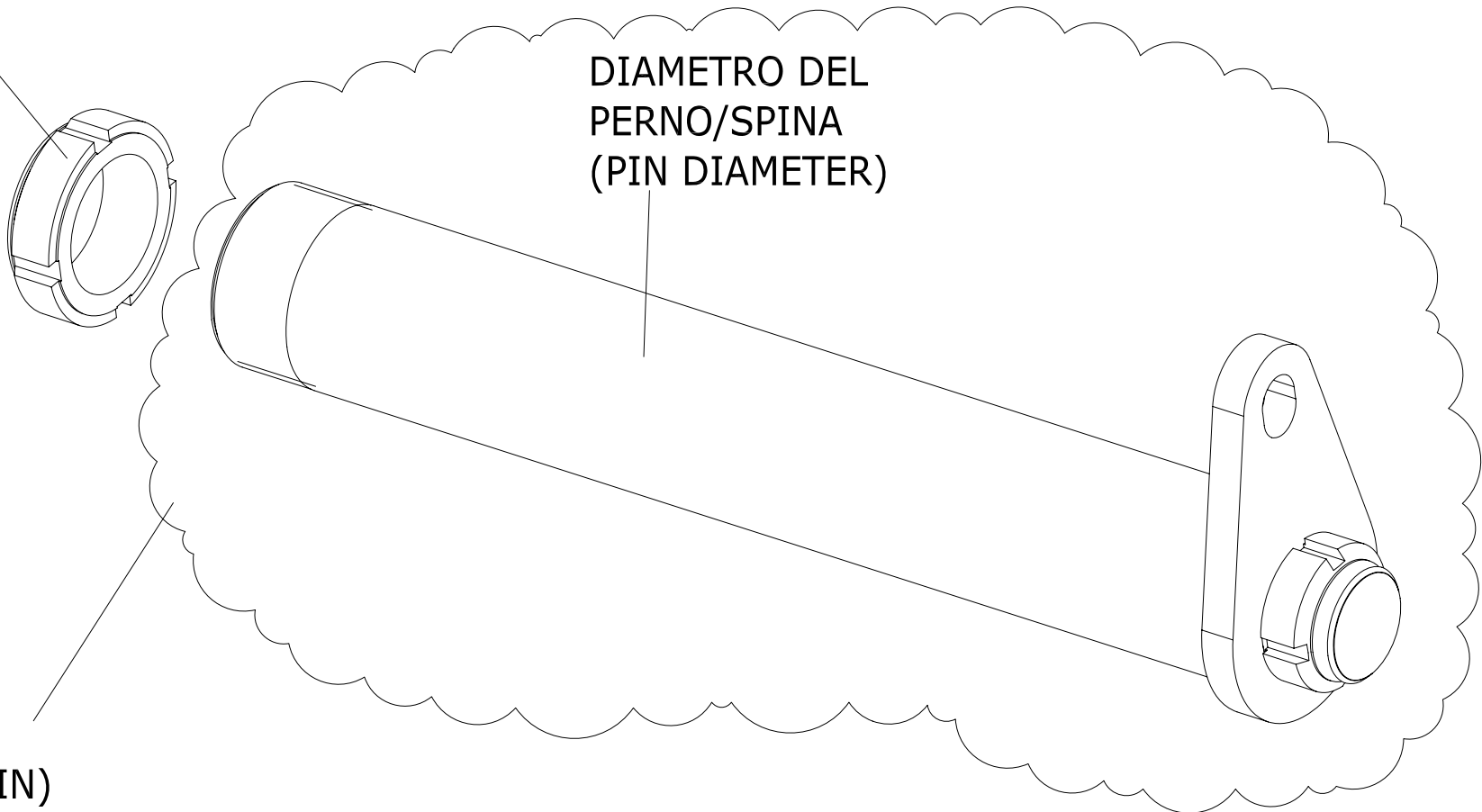

PERNO/SPINA (PIN)



IL CODICE DEL PERNO A RICAMBIO COMPRENDE LA GOCCIA MONTATA E LA GHIERA DI FISSAGGIO DELLA GOCCIA



THE CODE OF A PIN INCLUDES DROP PARTS MOUNTED AND THE LOCK NUT TO FIXING THE DROP, ALL THESE PARTS ARE SHIPPED ALREADY MOUNTED TOGETHER



<b>DIAMETRO DEL PERNO/SPINA mm SISTEMA METRICO (PIN DIAMETER mm METRIC)</b>	<b>GHIERA (LOCKNUTS CODE)</b>	<b>DADO (NUTS CODE)</b>
25	BG4	
30	BG5	
35	BG3	
40	BG2	
45	BG7	
50	BG8	
20 (DIAMETER OF THREADED PART M17 PITCH=1)	BG1	
20 (DIAMETER OF THREADED PART M20 PITCH=1)	BG6	
20 (DIAMETER OF THREADED PART M20 PITCH=1,5)	BG12	

POS	Codice	U.M.	 Descrizione	 Description
BC1	BC000100	NR	COPPIGLIA 4X40	COTTER PIN 4x40
BC2	BC000200	NR	COPPIGLIA 5X40	COTTER PIN 5x40
BC3	BC000300	NR	SEEGER ESTERNO Ø20	SEEGER EXTERNAL Ø20
BC4	BC000400	NR	SEEGER ESTERNO Ø8	SEEGER EXTERNAL Ø8
BD1	BD000100	NR	Dado Esagonale Flangiato Liscio PG DIN 6923 CI 8 M 14 Z.Bianca	Hex Flange Nut DIN 6923 CI Smooth PG 8 M 14 Z. white
BD2	BD000200	NR	Dado Esagonale Basso PG DIN 936 CI 04 M 8 Z.Bianca	Low Hex nut DIN 936 PG 04 M CI 8 Z. white
BD3	BD000300	NR	Dado Esagonale Alto PG UNI 5587 CI 8 M 8 Z.Bianca	Hex Nut High PG UNI 5587 CI 8 M 8 Z. white
BD4	BD000400	NR	Dado Alto Autobloccante PG DIN 982 CI 8 M 12 Z.Bianca	High Self Locking Nut DIN 982 PG 12 CI 8 M Z. white
BD5	BD000500	NR	Dado Alto Autobloccante PG DIN 982 CI 8 M 8 Z.Bianca	High Self Locking Nut DIN 982 PG CI 8 M 8 Z. white
BD6	BD000600	NR	Dado Esagonale Alto PG UNI 5587 CI 8 M 4 Z.Bianca	Hex Nut High PG UNI 5587 M 4 CI 8 Z. white
BD7	BD000700	NR	Dado Esagonale Basso PG DIN 936 CI 04 M 6 Z.Bianca	Low Hex nut DIN 936 PG 6 CI 04 M Z. white
BD8	BD000800	NR	Dado Basso Autobloccante PG DIN 985 CI 8 M 6 Z.Bianca	Low Self-locking nut DIN 985 PG 6 CI 8 M Z. white
BD9	BD000900	NR	Dado Alto Autobloccante PG DIN 982 CI 8 M 6 Z.Bianca	High Self Locking Nut DIN 982 PG CI 8 M6 Z. white
BD10	BD001000	NR	Dado Basso Autobloccante PG DIN 985 CI 8 M 5 Z.Bianca	Low Self-locking nut DIN 985 PG CI 8 M5 Z. white
BD11	BD001100	NR	Dado Alto Autobloccante PG DIN 982 CI 8 M 5 Z.Bianca	High Self Locking Nut DIN 982 PG CI 8 M5 Z. white
BD12	BD001200	NR	Dado Alto Autobloccante PG DIN 982 CI 8 M 4 Z.Bianca	High Self Locking Nut DIN 982 PG CI 8 M4 Z. white
BD13	BD001300	NR	Dado Alto Autobloccante PG DIN 982 CI 8 M 3 Z.Bianca	High Self Locking Nut DIN 982 PG CI 8 M3 Z. white



POS	Codice	U.M.	 Descrizione	 Description
BD14	BD001400	NR	Dado Alto Autobloccante PF DIN 982 CI 8 M 20 x 1,5 Z.Bianca	High Self Locking Nut DIN 982 PF CI 8 M 20 x 1.5 Z white
BD15	BD001500	NR	Dado Alto Autobloccante PG DIN 982 CI 8 M 10 Z.Bianca	High Self Locking Nut DIN 982 PG CI 8 M10 Z. white
BD16	BD001600	NR	Dado Esagonale Alto PG UNI 5587 CI 8 M 3 Z.Bianca	Hex Nut High PG UNI 5587 CI 8 M3 Z. white
BD17	BD001700	NR	Dado Basso Autobloccante PG DIN 985 CI 8 M 8 Z.Bianca	Low Self-locking nut DIN 985 PG CI 8 M8 Z. white
BD18	BD001800	NR	Dado Alto Autobloccante PG DIN 982 CI 8 M 16 Z.Bianca	High Self Locking Nut DIN 982 PG CI 8 M16 Z. white
BD19	BD001900	NR	Dado Alto Autobloccante PF DIN 982 CI 8 M 20 x 1,5 Z.Bianca H=20 ribassato	High Self Locking Nut DIN 982 PF CI 8 M 20 x 1.5 Z White H = 20 low
BD22	BD002200	NR	Dado Alto Autobloccante PG DIN 982 CI 8 M 14 Z.Bianca	Hex Flange Nut DIN 982 CI 8 M 14 Z. white
BD23	BD002300	NR	Dado Basso Autobloccante PG DIN 985 CI 8 M 10 Z.Bianca	Low Self-locking nut DIN 985 PG CI 8 M 10 Z. white
BD24	BD002400	NR	Dado Alto Autobloccante PG DIN 982 CI 8 M 24 Z.Bianca	High Self Locking Nut DIN 982 PG CI 8 M24 Z. white
BD25	BD002500	NR	Dado Esagonale Alto PG UNI 5587 CI 8 M 6 Z.Bianca	Hex Nut High PG UNI 5587 M 6 CI 8 Z. white
BD26	BD002600	NR	Dado Esagonale Alto PG UNI 5587 CI 8 M 10 Z.Bianca	Hex Nut High PG UNI 5587 M 10 CI 8 Z. white
BD27	BD002700	NR	Dado Alto Autobloccante PG DIN 982 CI 8 M 18 Z.Bianca	High Self Locking Nut DIN 982 PG CI 8 M18 Z. white
BD28	BD002800	NR	Dado Basso Autobloccante PG DIN 985 CI 8 M 16 Z.Bianca	Low Self-locking nut DIN 985 PG CI 8 M 16 Z. white
BD29	BD002900	NR	Dado Esagonale Alto PG UNI 5587 CI 8 M 5 Z.Bianca	Hex Nut High PG UNI 5587 M 5 CI 8 Z. white
BD30	BD003000	NR	Dado Esagonale Alto PG UNI 5587 CI 12 M 5 Z.Bianca	Hex Nut High PG UNI 5587 M 5 CI 12 Z. white
BD31	BD003100	NR	Dado Esagonale Alto PG UNI 5587 CI 16 M 5 Z.Bianca	Hex Nut High PG UNI 5587 M 5 CI 16 Z. white
BD32	BD003200	NR	Dado Alto Autobloccante PG DIN 982 CI 8 M 20 Z.Bianca	High Self Locking Nut DIN 982 PG CI 8 M20 Z. white

POS	Codice	U.M.	 Descrizione	 Description
BG1	BG000100	NR	Ghiera autobloccante GN CI 6 GN 3 D. 17 x 1 Z.Bianca	Self-locking nut GN GN 3 CI 6 D. 17 x 1 Z. white
BG2	BG000200	NR	Ghiera autobloccante pesante CI 6 GUP 40 x 1,5 Z.Bianca	Self-locking nut heavy CI 6 GUP 40 x 1.5 Z white
BG3	BG000300	NR	Ghiera autobloccante pesante CI 6 GUP 35 x 1,5 Z.Bianca	Self-locking nut heavy CI 6 GUP 35 x 1.5 Z white
BG4	BG000400	NR	Ghiera autobloccante pesante CI 6 GUP 25 x 1,5 Z.Bianca	Self-locking nut heavy CI 6 GUP 25 x 1.5 Z white
BG5	BG000500	NR	Ghiera autobloccante pesante CI 6 GUP 30 x 1,5 Z.Bianca	Self-locking nut heavy CI 6 GUP 30 x 1.5 Z white
BG6	BG000600	NR	Ghiera autobloccante pesante CI 6 GUP 20 x 1 Z.Bianca	Self-locking nut heavy CI 6 GUP 20 x 1 Z. white
BG7	BG000700	NR	Ghiera autobloccante GN CI 6 GN 3 D. 45 x 1,5 Z.Bianca	NUT
BG8	BG000800	NR	Ghiera autobloccante GN CI 6 GN 3 D. 50 x 1,5 Z.Bianca	NUT
BG9	BG000900	NR	Ghiera autobloccante GN CI 6 GN 3 D. 20 x 1,5 Z.Bianca	NUT
BG10	BG001000	NR	Ghiera autobloccante ribassata CI 6 GUK 25 x 1,5 Z.Bianca	Self-locking nut lowered CI 6 GUK 25 x 1.5 Z.Bianca
BG11	BG001100	NR	Ghiera autobloccante ribassata CI 6 GUK 20 x 1 Z.Bianca	Self-locking nut lowered CI 6 GUK 20 x 1 Z.Bianca
BG12	BG001200	NR	Ghiera autobloccante ribassata CI 6 GUA 20 x 1.5 Z.Bianca	Self-locking nut lowered CI 6 GUA 20 x 1.5 Z.Bianca
BG13	BG001300	NR	Ghiera autobloccante ribassata CI 6 GUK 30 x 1.5 Z.Bianca	Self-locking nut lowered CI 6 GUK 30 x 1.5 Z.Bianca
BG14	BG001400	NR	Ghiera autobloccante ribassata CI 6 GUK 45 x 1.5 Z.Bianca	Self-locking nut lowered CI 6 GUK 45 x 1.5 Z.Bianca
BG15	BG001500	NR	Ghiera autobloccante ribassata CI 6 GUK 50 x 1.5 Z.Bianca	Self-locking nut lowered CI 6 GUK 50 x 1.5 Z.Bianca
BG16	BG001600	NR	Ghiera autobloccante ribassata CI 6 GUK 55 x 1.5 Z.Bianca	Self-locking nut lowered CI 6 GUK 55 x 1.5 Z.Bianca
BI1	BI000100	NR	INSERTO ESAGONALE M6	INSERT HEX M6
BI2	BI000200	NR	INSERTO ESAGONALE M5	INSERT HEX M5

POS	Codice	U.M.	 Descrizione	 Description
BR1	BR000100	NR	Grower sez.rett.spigoli vivi pesante UNI 9195 Acc.Molle D 6 Z.D.Bianca	Grower sez.rett. sharp heavy UNI 9195 Acc.Molle D 6 Z.D. white
BR2	BR000200	NR	Rondella Piana DIN 125-A HV100 D 4 Z.Bianca	Plain washer DIN 125-A HV100 D 4 Z. white
BR3	BR000300	NR	Rondella Piana DIN 125-A HV100 D 5 Z.Bianca	Plain washer DIN 125-A HV100 D 5 Z. white
BR4	BR000400	NR	Rondella Piana DIN 125-A HV100 D 6 Z.Bianca	Plain washer DIN 125-A HV100 D 6 Z. white
BR5	BR000500	NR	Rondella Piana DIN 125-A HV100 D 8 Z.Bianca	Plain washer DIN 125-A HV100 D 8 Z. white
BR6	BR000600	NR	Rondella Piana DIN 125-A HV100 D 10 Z.Bianca	Plain washer DIN 125-A HV100 D 10 Z. white
BR7	BR000700	NR	Rondella Piana DIN 125-A HV100 D 12 Z.Bianca	Plain washer DIN 125-A HV100 D 12 Z. white
BR8	BR000800	NR	Rosetta piana fascia larga e=3d DIN 9021 HV100 D 10 x 30 x 2,5 Z.Bianca	Wide band and flat washer DIN 9021 HV100 3d = D 10 x 30 x 2.5 Z white
BR9	BR000900	NR	Rosetta piana fascia larga e=3d DIN 9021 HV100 D 12 x 36 x 2,5 Z.Bianca	Wide band and flat washer DIN 9021 HV100 3d = D 12 x 36 x 2.5 Z white
BR10	BR001000	NR	Rondella x Carpenteria DIN 6916 HV 300 D 16 Z.Bianca	Carpentry washer DIN 6916 HV 300 D 16 Z white
BR11	BR001100	NR	Rosette speciali HV100 D 25 x 51 x 1 Z.Bianca	Special washers HV100 D 25 x 51 x 1 Z. white
BR13	BR001300	NR	Rondella dentellatura esterna DIN 6798-A Acc.Molle D 3 Z.D.Bianca	Washer external serration DIN 6798-A Acc.Molle D 3 ZD white
BR14	BR001400	NR	Rosetta piana fascia larga e=3d DIN 9021 HV100 D 5 x 15 x 1,2 Z.Bianca	Wide band and flat washer DIN 9021 HV100 3d = D 5 x 15 x 1.2 Z whit
BR15	BR001500	NR	Rosetta piana fascia larga e=3d DIN 9021 HV100 D 6 x 18 x 1,5 Z.Bianca	Wide band and flat washer DIN 9021 HV100 3d = D 6 x 18 x 1.5 Z white
BR16	BR001600	NR	Rosetta piana fascia larga e=3d DIN 9021 HV100 D 8 x 24 x 2 Z.Bianca	Wide band and flat washer DIN 9021 HV100 3d = D 8 x 24 x 2 Z. white
BR17	BR001700	NR	Rosetta piana fascia larga e=3d DIN 9021 HV100 D 4 x 12 x 1 Z.Bianca	Wide band and flat washer DIN 9021 HV100 D = 3d 4 x 12 x 1 Z. white

POS	Codice	U.M.	 Descrizione	 Description
BR18	BR001800	NR	Rondella Piana DIN 125-A NYLON D 4	Plain washer DIN 125-A NYLON D 4
BR19	BR001900	NR	Rondella Piana DIN 125-A HV100 D 3 Z.Bianca	Plain washer DIN 125-A HV100 D 3 Z. white
BR20	BR002000	NR	Rondella Piana DIN 125-A HV100 D 16 Z.Bianca	Plain washer DIN 125-A HV100 D 16 Z. white
BR21	BR002100	NR	Rosetta piana fascia larga e=3d DIN 9021 HV100 D 16 x 48 x 4 Z.Bianca	Wide band and flat washer DIN 9021 HV100 3d = D 16 x 48 x 4 Z. white
BR22	BR002200	NR	Grower sez.rett.spigoli vivi pesante UNI 9195 Acc.Molle D 8 Z.D.Bianca	Grower section. rect. sharp heavy UNI 9195 Stainless Springs D 8 Z.D. white
BR23	BR002300	NR	Rosetta piana fascia larga e=3d DIN 9021 HV100 D 3 x 12 x 1 Z.Bianca	Wide band and flat washer DIN 9021 HV100 D = 3d 3 x 12 x 1 Z. white
BR24	BR002400	NR	Rosetta piana fascia larga e=3d DIN 9021 HV100 D 14 x 42 x 3 Z.Bianca	Wide band and flat washer DIN 9021 HV100 D = 3d 14 x 42 x 3 Z. white
BR25	BR002500	NR	Grower sez.rett.spigoli vivi pesante UNI 9195 Acc.Molle D 10 Z.D.Bianca	Grower sez.rett. sharp heavy UNI 9195 Acc.Molle D 10 Z.D. white
BR26	BR002600	NR	Rondella Piana DIN 125-A D 30 Z.Bianca	Plain washer DIN 125-A D 30 Z. white
BR27	BR002700	NR	Rondella Piana DIN 125-A HV100 D 14 Z.Bianca	Plain washer DIN 125-A HV100 D 14 Z. white
BR28	BR002800	NR	Rosetta piana fascia larga D 6 x 24 x 2 Z.Bianca	Wide band and flat washer D 6 x 24 x 2 Z white
BR29	BR002900	NR	Rondella Piana DIN 125-A HV100 D 18 Z.Bianca	Plain washer DIN 125-A HV100 D 18 Z. white
BR30	BR003000	NR	Rondella Piana DIN 125-A HV100 D 20 Z.Bianca	Plain washer DIN 125-A HV100 D 20 Z. white
BR31	BR003100	NR	Grower sez.rett.spigoli vivi pesante UNI 9195 Acc.Molle D 12 Z.D.Bianca	Grower sez.rett. sharp heavy UNI 9195 Acc.Molle D 12 Z.D. white
BR32	BR003200	NR	Rosette speciali HV100 D 30 x 42 x 0.5 Z.Bianca	Special washers HV100 D 30 x 42 x 0.5 Z. white
BR33	BR003300	NR	Rosette speciali HV100 D 30 x 61 x 1 Z.Bianca	Special washers HV100 D 30 x 61 x 1 Z. white
BR34	BR003400	NR	Rosette speciali HV100 D 42 x 52 x 0.2 Z.Bianca	Special washers HV100 D 42 x 52 x 0.2 Z. white



POS	Codice	U.M.	 Descrizione	 Description
BR35	BR003500	NR	Rosette speciali HV100 D 42 x 52 x 0.3 Z.Bianca	Special washers HV100 D 42 x 52 x 0.3 Z. white
BR36	BR003600	NR	Rosette speciali HV100 D 42 x 52 x 1 Z.Bianca	Special washers HV100 D 42 x 52 x 1 Z. white
BR37	BR003700	NR	Rosette speciali HV100 D 42 x 52 x 1.5 Z.Bianca	Special washers HV100 D 42 x 52 x 1.5 Z. white
BR38	BR003800	NR	Rosette speciali HV100 D 42 x 52 x 2 Z.Bianca	Special washers HV100 D 42 x 52 x 2 Z. white
BR39	BR003900	NR	Rosetta piana fascia larga e=3d DIN 9021 HV100 D 18 x 48 x 4 Z.Bianca	Wide band and flat washer DIN 9021 HV100 3d = D 18 x 48 x 4 Z. white
BR40	BR004000	NR	Rosetta SCHNORR zincate D 6	washer SCHNORR galvanized D 6
BR41	BR004100	NR	Grower sez.rett.spigoli vivi pesante UNI 9195 Acc.Molle D 14 Z.D.Bianca	Grower sez.rett. sharp heavy UNI 9195 Acc.Molle D 14 Z.D. white
BR42	BR004200	NR	Rondella x Carpenteria DIN 6916 HV 300 D 14 Z.Bianca	Carpentry washer DIN 6916 HV 300 D 14 Z white
BS1	BS000100	NR	GRANO FILETTATO M6X12	WHEAT THREAD M6X12
BS2	BS000200	NR	SPINA CIL. 8x16 UNI 6364-A h6 CMT + TMP	PIN CYLINDER 8 x 16 UNI 6364-A CMT h6 + TMP
BS3	BS000300	NR	PRIGIONIERO M10X35	STUD M10X35
BV1	BV000100	NR	Vite TE Parziale Filetto PG DIN 931 CI 8.8 M 8 x 80 Z.Bianca	Screw Partial Thread DIN 931 PG CI 8.8 M 8 x 80 Z. white
BV2	BV000200	NR	Vite TE Tutto Filetto PG DIN 933 CI 8.8 M 8 x 60 Z.Bianca	Screw All Thread DIN 933 PG CI 8.8 M 8 x 60 Z. white
BV3	BV000300	NR	Vite TCEI PG DIN 912 CI 8.8 M 8 x 60 Z.Bianca	Screw DIN 912 PG CI 8.8 M8 x 60 Z. white
BV4	BV000400	NR	Vite TE Parziale Filetto PG DIN 931 CI 8.8 M 8 x 50 Z.Bianca	Screw Partial Thread DIN 931 PG CI 8.8 M 8 x 50 Z. white
BV5	BV000500	NR	Vite TCEI PG DIN 912 CI 8.8 M 8 x 45 Z.Bianca	Screw DIN 912 PG CI 8.8 M8 x 45 Z. white
BV6	BV000600	NR	Vite TCEI PG DIN 912 CI 8.8 M 8 x 40 Z.Bianca	Screw DIN 912 PG CI 8.8 M8 x 40 Z.Bianca

POS	Codice	U.M.	 Descrizione	 Description
BV7	BV000700	NR	Vite TE Tutto Filetto PG DIN 933 CI 8.8 M 8 x 35 Z.Bianca	Screw All Thread DIN 933 PG CI 8.8 M 8 x 35 Z. white
BV8	BV000800	NR	Vite TE Tutto Filetto PG DIN 933 CI 8.8 M 8 x 30 Z.Bianca	Screw All Thread DIN 933 PG CI 8.8 M 8 x 30 Z. white
BV9	BV000900	NR	Vite TE Tutto Filetto PG DIN 933 CI 8.8 M 8 x 25 Z.Bianca	Screw All Thread DIN 933 PG CI 8.8 M 8 x 25 Z. white
BV10	BV001000	NR	Vite TCEI PG DIN 912 CI 8.8 M 8 x 25 Z.Bianca	Screw DIN 912 PG CI 8.8 M8 x 25 Z. white
BV11	BV001100	NR	Vite TE Tutto Filetto PG DIN 933 CI 8.8 M 8 x 20 Z.Bianca	Screw All Thread DIN 933 PG CI 8.8 M 8 x 20 Z. white
BV12	BV001200	NR	Vite TE Tutto Filetto PG DIN 933 CI 8.8 M 8 x 16 Z.Bianca	Screw All Thread DIN 933 PG CI 8.8 M 8 x 16 Z. white
BV13	BV001300	NR	Vite TCEI PG DIN 912 CI 8.8 M 8 x 16 Z.Bianca	Screw DIN 912 PG CI 8.8 M8 x 16 Z. white
BV14	BV001400	NR	Vite TE Tutto Filetto PG DIN 933 CI 8.8 M 8 x 14 Z.Bianca	Screw All Thread DIN 933 PG CI 8.8 M 8 x 14 Z. white
BV15	BV001500	NR	Vite TCEI PG DIN 912 CI 8.8 M 6 x 45 Z.Bianca	Screw DIN 912 M6 x 45 CI 8.8 Z. white
BV16	BV001600	NR	Vite TCEI PG DIN 912 CI 8.8 M 6 x 30 Z.Bianca	Screw DIN 912 M6 x 30 CI 8.8 Z. white
BV17	BV001700	NR	Vite TSPEI PG DIN 7991 CI 10.9 M 6 x 30 Z.Bianca	screw DIN 7991 CI 10.9 M 6 x 30 Z. white
BV18	BV001800	NR	Vite TE Tutto Filetto PG DIN 933 CI 8.8 M 6 x 30 Z.Bianca	Screw All Thread DIN 933 PG CI 8.8 M 6 x 30 Z. white
BV19	BV001900	NR	Vite TBEI PG ISO 7380 CI 10.9 M 6 x 30 Z.Bianca	screw ISO 7380 CI 10.9 M 6 x 30 Z. white
BV20	BV002000	NR	Vite TE Tutto Filetto PG DIN 933 CI 8.8 M 6 x 12 Z.Bianca	Screw All Thread DIN 933 PG CI 8.8 M 6 x 12 Z. white
BV21	BV002100	NR	Vite TCEI PG DIN 912 CI 8.8 M 6 x 12 Z.Bianca	Screw DIN 912 PG CI 8.8 M 6 x 12 Z. white
BV22	BV002200	NR	Vite TCEI PG DIN 912 CI 8.8 M 5 x 45 Z.Bianca	Screw DIN 912 PG CI 8.8 M 5 x 45 Z. white
BV23	BV002300	NR	Vite TE UNF ANSI B18.2.1 GR.5 5/16 x 1" Z.Bianca	Screw UNF ANSI B18.2.1 GR.5 5/16 x 1 "Z. White
BV24	BV002400	NR	Vite TC Croce PG DIN 7985 CI 4.8 M 4 x 8 Z.Bianca	Cross head screw DIN 7985 PG CI 4.8 M 4 x 8 Z. white

POS	Codice	U.M.	 Descrizione	 Description
BV25	BV002500	NR	Vite TCEI PG DIN 912 CI 8.8 M 4 x 16 Z.Bianca	Screw DIN 912 PG CI 8.8 M 4 x 16 Z. white
BV26	BV002600	NR	Vite TCEI PG DIN 912 CI 8.8 M 6 x 50 Z.Bianca	Screw DIN 912 PG CI 8.8 M 6 x 50 Z. white
BV27	BV002700	NR	Vite TSPEI PG DIN 7991 CI 10.9 M 6 x 40 Z.Bianca	screw DIN 7991 CI 10.9 M 6 x 40 Z. white
BV28	BV002800	NR	Vite TSPEI PG DIN 7991 CI 10.9 M 6 x 25 Z.Bianca	screw DIN 7991 CI 10.9 M 6 x 25 Z. white
BV29	BV002900	NR	Vite TE Tutto Filetto PG DIN 933 CI 8.8 M 6 x 25 Z.Bianca	Screw All Thread DIN 933 PG CI 8.8 M 6 x 25 Z. white
BV30	BV003000	NR	Vite TE Tutto Filetto PG DIN 933 CI 8.8 M 6 x 22 Z.Bianca	Screw All Thread DIN 933 PG CI 8.8 M 6 x 22 Z. white
BV31	BV003100	NR	Vite TSPEI PG DIN 7991 CI 10.9 M 6 x 20 Z.Bianca	screw DIN 7991 CI 10.9 M 6 x 20 Z. white
BV32	BV003200	NR	Vite TE Tutto Filetto PG DIN 933 CI 8.8 M 6 x 20 Z.Bianca	Screw All Thread DIN 933 PG CI 8.8 M 6 x 20 Z. white
BV33	BV003300	NR	Vite TCEI PG DIN 912 CI 8.8 M 6 x 20 Z.Bianca	Screw DIN 912 PG CI 8.8 M 6 x 20 Z. white
BV34	BV003400	NR	Vite TE Tutto Filetto PG DIN 933 CI 8.8 M 6 x 16 Z.Bianca	Screw All Thread DIN 933 PG CI 8.8 M 6 x 16 Z. white
BV35	BV003500	NR	Vite TBEI PG ISO 7380 CI 10.9 M 6 x 16 Z.Bianca	screw ISO 7380 CI 10.9 M 6 x 16 Z. white
BV36	BV003600	NR	Vite TCEI PG DIN 912 CI 8.8 M 5 x 8 Z.Bianca	Screw DIN 912 PG CI 8.8 M 5 x 8 Z. white
BV37	BV003700	NR	Vite TSPEI PG DIN 7991 CI 10.9 M 5 x 60 Z.Bianca	screw DIN 7991 CI 10.9 M 5 x 60 Z. white
BV38	BV003800	NR	Vite TE Parziale Filetto PG DIN 931 CI 8.8 M 5 x 60 Z.Bianca	Screw Partial Thread DIN 931 PG CI 8.8 M 5 x 60 Z. white
BV39	BV003900	NR	Vite TCEI PG DIN 912 CI 8.8 M 5 x 60 Z.Bianca	Screw DIN 912 PG CI 8.8 M 5 x 60 Z. white
BV40	BV004000	NR	Vite TE Parziale Filetto PG DIN 931 CI 8.8 M 5 x 55 Z.Bianca	Screw Partial Thread DIN 931 PG CI 8.8 M 5 x 55 Z. white
BV41	BV004100	NR	Vite TE Tutto Filetto PG DIN 933 CI 8.8 M 5 x 16 Z.Bianca	Screw All Thread DIN 933 PG CI 8.8 M 5 x 16 Z. white
BV42	BV004200	NR	Vite TC Croce PG DIN 7985 CI 4.8 M 5 x 16 Z.Bianca	Cross head screw DIN 7985 PG CI 4.8 M 5 x 16 Z. white

POS	Codice	U.M.	 Descrizione	 Description
BV43	BV004300	NR	Vite TE Tutto Filetto PG DIN 933 CI 8.8 M 5 x 12 Z.Bianca	Screw All Thread DIN 933 PG CI 8.8 M 5 x 12 Z. white
BV44	BV004400	NR	Vite TE UNF ANSI B18.2.1 GR.5 5/16 x 1"1/4 Z.Bianca	Screw UNF ANSI B18.2.1 GR.5 5/16 x 1 "1/4 Z. White
BV45	BV004500	NR	Vite TE UNF ANSI B18.2.1 GR.5 5/16 x 1"1/4 Z.Bianca	Screw UNF ANSI B18.2.1 GR.5 5/16 x 1 "1/4 Z. White
BV46	BV004600	NR	Vite TCEI PG DIN 912 CI 8.8 M 4 x 40 Z.Bianca	Screw DIN 912 PG CI 8.8 M 4 x 40 Z. white
BV47	BV004700	NR	Vite Trilob. Autoform. TC Croce PG DIN 7500-C C15 M 4 x 40 Z.Bianca	Trilob Screw. Autoform. TC Cross PH DIN 7500-C C 15 M 4 x 40 Z. white
BV48	BV004800	NR	Vite Trilob. Autoform. TC Croce PG DIN 7500-C C15 M 4 x 20 Z.Bianca	Trilob Screw. Autoform. TC Cross PG DIN 7500-C C15 M 4 x 20 Z. white
BV49	BV004900	NR	Vite TC Croce PG DIN 7985 CI 4.8 M 4 x 16 Z.Bianca	Cross head screw DIN 7985 PG CI 4.8 M 4 x 16 Z. white
BV50	BV005000	NR	VITE AUTOFIETTANTE TE C/BORDINO DIN 6928 C15 4,8X50 Z.Bianca	TAPPING SCREW TE C / BORDINO DIN 6928 C15 4.8 X50 Z. white
BV51	BV005100	NR	VITE AUTOFIETTANTE TE C/BORDINO DIN 6928 C15 4,8X25 Z.Bianca	TAPPING SCREW TE C / BORDINO DIN 6928 C15 4.8 X25 Z. white
BV52	BV005200	NR	Vite TCEI PG DIN 912 CI 12.9 M 3 x 25 Z.D.Bianca	Screw DIN 912 M 3 CI 12.9 x 25 Z.D. white
BV53	BV005300	NR	Vite TSPEI PG DIN 7991 CI 10.9 M 3 x 14 Z.Bianca	Screw DIN 7991 CI 10.9 M 3 x 14 Z. white
BV54	BV005400	NR	Vite Autofil.TC Croce DIN 7981 C15 3,5 x 6,5 Z.Bianca	Autofil.TC Cross Screw DIN 7981 C15 3.5 x 6.5 Z. white
BV55	BV005500	NR	Vite TE Parziale Filetto PG DIN 931 CI 10.9 M 16 x 55 Z.D.Bianca	Screw Partial Thread DIN 931 PG CI 10.9 M 16 x 55 ZD white
BV56	BV005600	NR	Vite TE Tutto Filetto PG DIN 933 CI 8.8 M 16 x 40 Z.Bianca	Screw All Thread DIN 933 PG CI 8.8 M 16 x 40 Z. white
BV57	BV005700	NR	Vite TE Parziale Filetto PG DIN 931 CI 10.9 M 16 x 220 Z.Deidro Bianche	Screw Partial Thread DIN 931 PG CI 10.9 M 16 x 220 Z. dehydro White
BV58	BV005800	NR	Vite TE 8.8 DIN933 M16x20 Testa Alta 8 Zn Bianca	Screw M16x20 DIN933 8.8 Head High 8 Zn White
BV59	BV005900	NR	Vite TE Tutto Filetto PG DIN 933 CI 8.8 M 12 x 16 Z.Bianca	Screw All Thread DIN 933 PG CI 8.8 M 12 x 16 Z. white

POS	Codice	U.M.	 Descrizione	 Description
BV60	BV006000	NR	Vite TE Parziale Filetto PG DIN 931 CI 8.8 M 12 x 120 Z.Bianca	Screw Partial Thread DIN 931 PG CI 8.8 M 12 x 120 Z. white
BV61	BV006100	NR	Vite TE Parziale Filetto PG DIN 931 CI 8.8 M 10 x 50 Z.Bianca	Screw Partial Thread DIN 931 PG CI 8.8 M 10 x 50 Z. white
BV62	BV006200	NR	Vite TE Tutto Filetto PG DIN 933 CI 8.8 M 10 x 35 Z.Bianca	Screw All Thread DIN 933 PG CI 8.8 M 10 x 35 Z. white
BV63	BV006300	NR	Vite TSPEI PG DIN 7991 CI 10.9 M 10 x 30 Z.Bianca	Screw DIN 7991 CI 10.9 M 10 x 30 Z. white
BV64	BV006400	NR	Vite TE Tutto Filetto PG DIN 933 CI 8.8 M 10 x 30 Z.Bianca	Screw All Thread DIN 933 PG CI 8.8 M 10 x 30 Z. white
BV65	BV006500	NR	Vite TCEI PG DIN 912 CI 12.9 M 10 x 25 Geo 321 A	Screw DIN 912 PG CI 12.9 M 10 x 25 Geo 321 A
BV66	BV006600	NR	Vite TCEI PG DIN 912 CI 8.8 M 10 x 25 Z.Bianca	Screw DIN 912 PG CI 8.8 M 10 x 25 Z. white
BV67	BV006700	NR	Vite TE Tutto Filetto PG DIN 933 CI 8.8 M 10 x 20 Z.Bianca	Screw All Thread DIN 933 PG CI 8.8 M 10 x 20 Z. white
BV68	BV006800	NR	Vite TE Tutto Filetto PG DIN 933 CI 8.8 M 10 x 18 Z.Bianca	Screw All Thread DIN 933 PG CI 8.8 M 10 x 18 Z. white
BV69	BV006900	NR	Vite Trilob. Autoform. TSP Croce PG DIN 7500-M C15 M 5 x 16 Z.Bianca	Trilob Screw. Autoform. TSP Cross PG DIN 7500-M C15 M 5 x 16 Z. white
BV70	BV007000	NR	Vite TE Parziale Filetto PG DIN 931 CI 8.8 M 8 x 70 Z.Bianca	Screw Partial Thread DIN 931 PG CI 8.8 M 8 x 70 Z. white
BV71	BV007100	NR	Vite TE Parziale Filetto PG DIN 931 CI 8.8 M 8 x 65 Z.Bianca	Screw Partial Thread DIN 931 PG CI 8.8 M 8 x 65 Z. white
BV72	BV007200	NR	Vite TE Parziale Filetto PG DIN 931 CI 8.8 M 6 x 55 Z.Bianca	Screw Partial Thread DIN 931 PG CI 8.8 M 6 x 55 Z. white
BV73	BV007300	NR	Vite TCEI PG DIN 912 CI 8.8 M 6 x 55 Z.Bianca	Screw DIN 912 PG CI 8.8 M 6 x 55 Z. white
BV74	BV007400	NR	Vite TCEI PG DIN 912 CI 8.8 M 6 x 16 Z.Bianca	Screw DIN 912 PG CI 8.8 M 6 x 16 Z. white
BV75	BV007500	NR	Vite TSPEI PG DIN 7991 CI 10.9 M 6 x 10 Z.Bianca	Screw DIN 7991 CI 10.9 M 6 x 10 Z. white
BV76	BV007600	NR	Vite TCEI PG DIN 912 CI 8.8 M 5 x 55 Z.Bianca	Screw DIN 912 PG CI 8.8 M 5 x 55 Z. white

POS	Codice	U.M.	 Descrizione	 Description
BV77	BV007700	NR	Vite TC Croce PG DIN 7985 CI 4.8 M 6 x 16 Z.Bianca	Cross head screw DIN 7985 PG CI 4.8 M 6 x 16 Z. white
BV78	BV007800	NR	Vite Trilob. Autoform. TC Croce PG DIN 7500-C C15 M 5 x 12 Z.Bianca	Trilob Screw. Autoform. TC Cross PG DIN 7500-C C15 M 5 x 12 Z. white
BV79	BV007900	NR	Vite TE Tutto Filetto PG DIN 933 CI 8.8 M 4 x 35 Z.Bianca	Screw All Thread DIN 933 PG CI 8.8 M 4 x 35 Z. white
BV80	BV008000	NR	VITE AUTOFIETTANTE TE C/BORDINO DIN 6928 C15 4,8X35 Z.Bianca	TAPPING SCREW TE C / BORDINO DIN 6928 C15 4.8 X35 Z. white
BV81	BV008100	NR	Vite TCEI PG DIN 912 CI 12.9 M 3 x 14 Z.D.Bianca	Screw DIN 912 M 3 CI 12.9 x 14 Z.D. white
BV82	BV008200	NR	Vite TE Parziale Filetto PG DIN 931 CI 8.8 M 16 x 70 Z.Bianca	Screw Partial Thread DIN 931 PG CI 8.8 M 16 x 70 Z. white
BV83	BV008300	NR	Vite TE Parziale Filetto PG DIN 931 CI 8.8 M 16 x 260 Z.Bianca	Screw Partial Thread DIN 931 PG CI 8.8 M 16 x 260 Z. white
BV84	BV008400	NR	Vite TE Parziale Filetto PG DIN 931 CI 8.8 M 12 x 110 Z.Bianca	Screw Partial Thread DIN 931 PG CI 8.8 M 12 x 110 Z. white
BV85	BV008500	NR	Vite TE Tutto Filetto PG DIN 933 CI 8.8 M 10 x 40 Z.Bianca	Screw Thread DIN 933 PG CI 8.8 M 10 x 40 Z. white
BV86	BV008600	NR	Vite TCEI PG DIN 912 CI 8.8 M 8 x 65 Z.Bianca	Screw DIN 912 PG CI 8.8 M 8 x 65 Z. white
BV87	BV008700	NR	Vite TCEI PG DIN 912 CI 8.8 M 8 x 20 Z.Bianca	Screw DIN 931 PG CI 8.8 M 10 x 40 Z. white
BV88	BV008800	NR	Vite TCEI PG DIN 912 CI 10.9 M 10 x 18 Z.Bianca	Screw DIN 912 PG CI 10.9 M 10 x 18 Z. white
BV89	BV008900	NR	Vite TCEI PG DIN 912 CI 8.8 M 8 x 70 Z.Bianca	Screw DIN 912 PG CI 8.8 M 8 x 70 Z. white
BV91	BV009100	NR	Vite TE Tutto Filetto PG DIN 933 CI 8.8 M 6 x 40 Z.Bianca	Screw All Thread DIN 933 PG CI 8.8 M 6 x 40 Z. white
BV92	BV009200	NR	Vite TE Tutto Filetto PG DIN 933 CI 8.8 M 10 x 60 Z.Bianca	Screw All Thread DIN 933 PG CI 8.8 M 10 x 60 Z. white
BV93	BV009300	NR	Vite TSPEI PG DIN 7991 CI 10.9 M 5 x 20 Z.Bianca	screw DIN 7991 CI 10.9 M 5 x 20 Z. white
BV94	BV009400	NR	Vite TC Croce PG DIN 7985 CI 4.8 M 4 x 12 Z.Bianca	Cross head screw DIN 7985 PG CI 4.8 M 4 x 12 Z. white



POS	Codice	U.M.	 Descrizione	 Description
BV95	BV009500	NR	Vite TE Tutto Filetto PG DIN 933 CI 8.8 M 4 x 12 Z.Bianca	Screw All Thread DIN 933 PG CI 8.8 M 4 x 12 Z. white
BV96	BV009600	NR	Vite TCEI PG DIN 912 CI 12.9 M 12 x 30 Dac 320A	Screw DIN 912 CI 12.9 M 12 x 30 Dac 320A
BV97	BV009700	NR	Vite Autofil.Testa Mezza Tonda C15 4,8 x 13 Z.Bianca	Half Round Head Self Tapping Screw C15 4,8 x 13
BV98	BV009800	NR	Vite TC Croce PG DIN 7985 CI 4.8 M 4 x 12 Z.Bianca	Screw DIN 7985 CI 4.8 M 4 x 12
BV99	BV009900	NR	Vite TE Parziale Filetto PG DIN 931 CI 8.8 M 5 x 65 Z.Bianca	Screw Partial Thread DIN 931 PG CI 8.8 M 5 x 65 Z. white
BV100	BV010000	NR	Vite Autofil.Testa Mezza Tonda C15 4,8 x 16 Z.Bianca	Half Round Head Self Tapping Screw C15 4,8 x 16
BV101	BV010100	NR	Vite TSPEI PG DIN 7991 CI 10.9 M 8 x 25 Z.Bianca	screw DIN 7991 CI 10.9 M 8 x 25 Z. white
BV102	BV010200	NR	Vite TCEI PG DIN 912 CI 8.8 M 4 x 30 Z.Bianca	Screw DIN 912 PG CI 8.8 M 4 x 30 White Z
BV103	BV010300	NR	Vite TSPEI PG DIN 7991 CI 10.9 M 5 x 16 Z.Bianca	Screw DIN 7991 CI 10.9 M 5 x 16 Z. white
BV104	BV010400	NR	Vite TCEI bassa PG DIN 7984 CI 10.9 M 12 x 18 Z.D.Bianca	Screw DIN 7984 low PG CI 10.9 M 12 x 18 Z. D. white
BV105	BV010500	NR	Vite TE Parziale Filetto PG DIN 931 CI 8.8 M 12 x 75 Z.Bianca	Screw Partial Thread DIN 931 PG CI 8.8 M 12 x 75 Z. white
BV106	BV010600	NR	Vite TE Tutto Filetto PG DIN 933 CI 8.8 M 8 x 22 Z.Bianca	Screw All Thread DIN 933 PG CI 8.8 M 8 x 22 Z. white
BV107	BV010700	NR	Vite TE Tutto Filetto PG DIN 933 CI 8.8 M 6 x 35 Z.Bianca	Screw All Thread DIN 933 PG CI 8.8 M 6 x 35 Z. white
BV108	BV010800	NR	Vite TE Parziale Filetto PG DIN 931 CI 8.8 M 4 x 45 Z.Bianca	Screw Partial Thread DIN 931 PG CI 8.8 M 4 x 45 Z. white
BV109	BV010900	NR	Vite TE Tutto Filetto PG DIN 933 CI 10.9 M 16 x 45 Z.D.Bianca	Screw All Thread DIN 933 PG CI 10.9 M 16 x 45 ZD white
BV110	BV011000	NR	Vite TE Parziale Filetto PG DIN 931 CI 10.9 M 16 x 100 Z.D.Bianca	Screw Partial Thread DIN 931 PG CI 10.9 M 16 x 100 ZD white
BV111	BV011100	NR	Vite TE Parziale Filetto PG DIN 931 CI 10.9 M 16 x 105 Z.D.Bianca	Screw Partial Thread DIN 931 PG CI 10.9 M 16 x 105 ZD white



POS	Codice	U.M.	 Descrizione	 Description
BV112	BV011200	NR	Vite TE Tutto Filetto PG DIN 933 CI 8.8 M 10 x 25 Z.Bianca	Screw All Thread DIN 933 PG CI 8.8 M 10 x 25 Z. white
BV113	BV011300	NR	Vite TSPEI PG DIN 7991 CI 10.9 M 6 x 50 Z.Bianca	TSPEI PG screw DIN 7991 CI 10.9 M 6 x 50 Z. white
BV114	BV011400	NR	Vite TSPEI PG DIN 7991 CI 10.9 M 8 x 25 Z.Bianca	TSPEI PG screw DIN 7991 CI 10.9 M 8 x 25 Z. white
BV115	BV011500	NR	Vite TE Tutto Filetto PG DIN 933 CI 8.8 M 10 x 45 Z.Bianca	Screw All Thread DIN 933 PG CI 8.8 M 10 x 45 Z. white
BV116	BV011600	NR	Vite TE Tutto Filetto PG DIN 933 CI 8.8 M 5 x 8 Z.Bianca	Screw All Thread DIN 933 PG CI 8.8 M 5 x 8 Z. white
BV117	BV011700	NR	Vite TE Tutto Filetto PG DIN 933 CI 8.8 M 8 x 18 Z.Bianca	Screw All Thread DIN 933 PG CI 8.8 M 8 x 18 Z. white
BV118	BV011800	NR	Vite TE Tutto Filetto PG DIN 933 CI 8.8 M 8 x 40 Z.Bianca	Screw All Thread DIN 933 PG CI 8.8 M 8 x 40 Z. white
BV119	BV011900	NR	Vite TCEI PG DIN 912 CI 8.8 M 8 x 100 Z.Bianca	Screw DIN 912 PG CI 8.8 M 8 x 100 Z. white
BV120	BV012000	NR	Vite TCEI PG DIN 912 CI 8.8 M 8 x 110 Z.Bianca	Screw DIN 912 PG CI 8.8 M 8 x 110 Z. white
BV121	BV012100	NR	Vite TE Parziale Filetto PG DIN 931 CI 8.8 M 5 x 75 Z.Bianca	Screw Partial Thread DIN 931 PG CI 8.8 M 5 x 75 Z. white
BV122	BV012200	NR	Vite TE Parziale Filetto PG DIN 931 CI 8.8 M 12 x 130 Z.Bianca	Screw Partial Thread DIN 931 PG CI 8.8 M 12 x 130 Z. white
BV123	BV012300	NR	Vite TC Croce PG DIN 7985 CI 4.8 M 4 x 8 Z.Bianca	Cross head screw DIN 7985 PG CI 4.8 M 4 x 8 Z. white
BV124	BV012400	NR	Vite TCEI PG DIN 912 CI 8.8 M 6 x 40 Z.Bianca	Screw DIN 912 PG CI 8.8 M 6 x 40 Z. white
BV125	BV012500	NR	Vite TE Tutto Filetto PG DIN 933 CI 8.8 M 4 x 20 Z.Bianca	Screw All Thread DIN 933 PG CI 8.8 M 4 x 20 Z. white
BV126	BV012600	NR	Vite TE UNC ANSI B18.2.1 GR.5 3/8 x 1" Z.Bianca	Screw UNC ANSI B18.2.1 GR.5 3/8 x 1" Z. White
BV127	BV012700	NR	Vite TE UNC ANSI B18.2.1 GR.5 3/8 x 1" 1/4Z.Bianca	Screw UNC ANSI B18.2.1 GR.5 3/8 x 1" 1/4 Z. White
BV128	BV012800	NR	Vite TE Tutto Filetto PG DIN 933 CI 8.8 M 4 x 16 Z.Bianca	Screw All Thread DIN 933 PG CI 8.8 M 4 x 16 Z. white
BV129	BV012900	NR	Vite TCEI PG DIN 912 CI 8.8 M 5 x 16 Z.Bianca	Screw DIN 912 PG CI 8.8 M 5 x 16 Z. white



POS	Codice	U.M.	 Descrizione	 Description
BV130	BV013000	NR	Vite TCEI PG DIN 912 CI 8.8 M 3 x 12 Z.Bianca	Screw DIN 912 PG CI 8.8 M 3 x 12 Z. white
BV131	BV013100	NR	Vite TSPEI PG DIN 7991 CI 10.9 M 5 x 30 Z.Bianca	TSPEI PG screw DIN 7991 CI 10.9 M 5 x 30 Z. white
BV132	BV013200	NR	Vite TSPEI PG DIN 7991 CI 10.9 M 5 x 55 Z.Bianca	TSPEI PG screw DIN 7991 CI 10.9 M 5 x 55 Z. white
BV133	BV013300	NR	Vite TE Tutto Filetto PG DIN 933 CI 8.8 M 3 x 25 Z.Bianca	Screw All Thread DIN 933 PG CI 8.8 M 3 x 25 Z. white
BV134	BV013400	NR	Vite TE Parziale Filetto PG DIN 931 CI 8.8 M 10 x 65 Z.Bianca	Screw Partial Thread DIN 931 PG CI 8.8 M 10 x 65 Z. white
BV135	BV013500	NR	Vite TCEI PG DIN 912 CI 8.8 M 12 x 50	Screw DIN 912 CI 8.8 M 12 x 50
BV136	BV013600	NR	Vite TSPEI PG DIN 7991 CI 10.9 M 5 x 25 Z.Bianca	TSPEI PG screw DIN 7991 CI 10.9 M 5 x 25 Z. white
BV137	BV013700	NR	Vite TCEI PG DIN 912 CI 8.8 M 8 x 30	Screw DIN 912 CI 8.8 M 8 x 30
BV138	BV013800	NR	Vite TC Croce PG DIN 7985 CI 4.8 M 5 x 10 Z.Bianca	Screw DIN 7985 CI 4.8 M 5 x 10
BV139	BV013900	NR	Vite TCEI PG DIN 912 CI 12.9 M 4 x 25 Z. Bianca	Screw DIN 912 CI 12.9 M 4 x 25 Z. Withe
BV140	BV014000	NR	Vite TE Parziale Filetto PG DIN 931 CI 8.8 M 5 x 70 Z.Bianca	Screw Partial Thread DIN 931 PG CI 8.8 M 5 x 70 Z. white
BV141	BV014100	NR	Vite TE Parziale Filetto PG DIN 931 CI 8.8 M 12 x 90 Z.Bianca	Screw Partial Thread DIN 931 PG CI 8.8 M 12 x 90 Z. white
BV142	BV014200	NR	Vite TE Parziale Filetto PG DIN 931 CI 8.8 M 8 x 55 Z.Bianca	Screw Partial Thread DIN 931 PG CI 8.8 M 8 x 55 Z. white
BV143	BV014300	NR	Vite TSPEI PG DIN 7991 CI 10.9 M 10 x 20 Z.Bianca	TSPEI PG screw DIN 7991 CI 10.9 M 10 x 20 Z. white
BV144	BV014400	NR	Vite TE Tutto Filetto PG DIN 933 CI 8.8 M 12 x 20 Z.Bianca	Screw All Thread DIN 933 PG CI 8.8 M 12 x 20 Z. white
BV145	BV014500	NR	Vite TE Tutto Filetto PG DIN 933 CI 8.8 M 12 x 35 Z.Bianca	Screw All Thread DIN 933 PG CI 8.8 M 12 x 35 Z. white
BV146	BV014600	NR	Vite TE Tutto Filetto PF DIN 961 CI 8.8 M 10 x 1,25 x 25 Z.Bianca	All PF thread hex head screw DIN 961 CI 8.8 M 10 x 1,25 x 25 Z.Bianca



POS	Codice	U.M.	 Descrizione	 Description
BV147	BV014700	NR	Vite TSPEI PG DIN 7991 CI 10.9 M 12 x 90 Z.Bianca	TSPEI PG screw DIN 7991 CI 10.9 M12 x 90 Z. white
BV148	BV014800	NR	Vite TSPEI PG DIN 7991 CI 10.9 M 6 x 16 Z.Bianca	TSPEI PG screw DIN 7991 CI 10.9 M6 x 16 Z. white
BV149	BV014900	NR	Vite TBEI PG ISO 7380 CI 10.9 M 6 x 20 Z.Bianca	Hex socket screw ISO 7380 PG CI 10.9 M 6 x 20 Z. white
BV150	BV015000	NR	Vite TE Tutto Filetto PG DIN 933 CI 10.9 M 14 x 40 Z.Bianca	Screw All Thread DIN 933 PG CI 10.9 M 14 x 40 Z. white
BV151	BV015100	NR	Vite TE Parziale Filetto PG DIN 931 CI 8.8 M 10 x 85 Z.Bianca	Screw Partial Thread DIN 931 PG CI 8.8 M 10 x 85 Z. white
BV152	BV015200	NR	Vite TE Parziale Filetto PG DIN 931 CI 8.8 M 10 x 75 Z.Bianca	Screw Partial Thread DIN 931 PG CI 8.8 M 10 x 75 Z. white
BV153	BV015300	NR	Vite TE Tutto Filetto PG DIN 933 CI 8.8 M14 x 45 Z.Bianca	Screw All Thread DIN 933 PG CI 8.8 M14 x 45 Z. white
BV154	BV015400	NR	Vite TCEI PG DIN 912 CI 12.9 M 8 x 35 GEOMET 321A	Screw DIN 912 CI 12.9 M 8 x 35 GEOMET 321A
BV155	BV015500	NR	Vite TCEI PG DIN 912 CI 12.9 M 5 x 20 GEOMET 321A	Screw DIN 912 CI 12.9 M 5 x 20 GEOMET 321A
BV156	BV015600	NR	Vite TBEI PG ISO 7380 CI 10.9 M 6 x 25 Z.Bianca	Hex socket screw ISO 7380 PG CI 10.9 M 6 x 25 Z. white
BV157	BV015700	NR	Vite TBEI PG ISO 7380 CI 10.9 M 8 x 20 Z.Bianca	Hex socket screw ISO 7380 PG CI 10.9 M 8 x 20 Z. white
BV158	BV015800	NR	Vite TBEI PG ISO 7380 CI 10.9 M 6 x 70 Z.Bianca	Hex socket screw ISO 7380 PG CI 10.9 M 6 x 70 Z. white
BV159	BV015900	NR	Vite TBEI PG ISO 7380 CI 10.9 M 10 x 20 Z.Bianca	Hex socket screw ISO 7380 PG CI 10.9 M 10 x 20 Z. white
BV160	BV016000	NR	Vite TSPEI PG DIN 7991 CI 10.9 M 4 x 16 Z.Bianca	TSPEI PG screw DIN 7991 CI 10.9 M4 x 16 Z. white
BV161	BV016100	NR	Vite TE UNC ANSI B18.2.1 GR.5 1/2 passo 13 L= 1" 1/4	UNC hex head screw ANSI B18.2.1 GR.5 1/2 11 L = 1 "1/4
BV162	BV016200	NR	Vite TCEI PG DIN 912 CI 12.9 M14 x 45 GEOMET 321A	Screw DIN 912 CI 12.9 M14 x 45 GEOMET 321A
BV163	BV016300	NR	Vite TCEI PG DIN 912 CI 8.8 M6 x 35 GEOMET 321A	Screw DIN 912 CI 8.8 M6 x 35 GEOMET 321A

POS	Codice	U.M.	 Descrizione	 Description
BV164	BV016400	NR	Vite TCEI PG DIN 912 CI 8.8 M10 x 35 GEOMET 321A	Screw DIN 912 CI 8.8 M10 x 35 GEOMET 321A
BV165	BV016500	NR	Vite TE Tutto Filetto PG DIN 933 CI 8.8 M8 x 12 Z.Bianca	Screw All Thread DIN 933 PG CI 8.8 M8 x 12 Z. white
BV166	BV016600	NR	Vite TCEI PG DIN 912 CI 8.8 M4 x 20 GEOMET 321A	Screw DIN 912 CI 8.8 M4 x 20 GEOMET 321A
BV167	BV016700	NR	Vite TCEI PG DIN 912 CI 8.8 M4 x 20 GEOMET 321A	All PF thread hex head screw DIN 961 CI 8.8 M 12 x 1,25 x 30 Z.Bianca
BV168	BV016800	NR	Vite TE Tutto Filetto PF DIN 961 CI 8.8 M 10 x 1,25 x 30 Z.Bianca	All PF thread hex head screw DIN 961 CI 8.8 M 10 x 1,25 x 30 Z.Bianca
BV169	BV016900	NR	Vite TCEI PG DIN 912 CI 8.8 M 10 x 1,25 x 30	Screw DIN 912 CI 8.8 M10 x 1,25 x 30
BV170	BV017000	NR	Vite TE Tutto Filetto PF DIN 961 CI 8.8 M 10 x 1,25 x 30 Z.Bianca	All PF thread hex head screw DIN 961 CI 8.8 M 10 x 1,25 x 60 Z.Bianca
BV171	BV017100	NR	Vite TE Tutto Filetto PF DIN 961 CI 8.8 M 12 x 1,25 x 25 Z.Bianca	All PF thread hex head screw DIN 961 CI 8.8 M 12 x 1,25 x 25 Z.Bianca
BV172	BV017200	NR	Vite TE UNC ANSI B18.2.1 GR.5 5/8 passo 11 L= 1" 1/2	UNC hex head screw ANSI B18.2.1 GR.5 5/8 11 L = 1 "1/2
BV173	BV017300	NR	Vite TE Tutto Filetto PG DIN 933 CI 8.8 M12 x 30 Z.Bianca	Screw All Thread DIN 933 PG CI 8.8 M12 x 30 Z. white
BV174	BV017400	NR	Vite TE Tutto Filetto PG DIN 933 CI 8.8 M5 x 45 Z.Bianca	Screw All Thread DIN 933 PG CI 8.8 M5 x 45 Z. white
BV175	BV017500	NR	Vite TE Tutto Filetto PG DIN 933 CI 8.8 M12 x 80 Z.Bianca	Screw All Thread DIN 933 PG CI 8.8 M12 x 80 Z. white
BV176	BV017600	NR	Vite TCEI PG DIN 912 CI 8.8 M6 x 25 GEOMET 321A	Screw DIN 912 CI 8.8 M6 x 25 GEOMET 321A
BV177	BV017700	NR	Vite TE Tutto Filetto PG DIN 933 CI 8.8 M12 x 85 Z.Bianca	Screw All Thread DIN 933 PG CI 8.8 M12 x 85 Z. white
BV178	BV017800	NR	Vite TE Tutto Filetto PG DIN 933 CI 8.8 M8 x 90 Z.Bianca	Screw All Thread DIN 933 PG CI 8.8 M8 x 90 Z. white
BV179	BV017900	NR	Vite TE Tutto Filetto PG DIN 933 CI 8.8 M5 x 40 Z.Bianca	Screw All Thread DIN 933 PG CI 8.8 M5 x 40 Z. white
BV180	BV018000	NR	Vite TE Tutto Filetto PG DIN 933 CI 8.8 M6 x 75 Z.Bianca	Screw All Thread DIN 933 PG CI 8.8 M6 x 75 Z. white

POS	Codice	U.M.	 Descrizione	 Description
BV181	BV018100	NR	Vite TE Tutto Filetto PG DIN 933 CI 8.8 M10 x 40 Z.Bianca	Screw All Thread DIN 933 PG CI 8.8 M10 x 40 Z. white
BV182	BV018200	NR	Vite TE Tutto Filetto PG DIN 933 CI 10.9 M 16 x 70 Z.Bianca	Screw All Thread DIN 933 PG CI 10.9 M 16 x 70 Z. white
BV183	BV018300	NR	Vite TE Tutto Filetto PG DIN 933 CI 8.8 M5 x 10 Z.Bianca	Screw All Thread DIN 933 PG CI 8.8 M5 x 10 Z. white
BV184	BV018400	NR	Vite TE Tutto Filetto PG DIN 933 CI 8.8 M10 x 16 Z.Bianca	Screw All Thread DIN 933 PG CI 8.8 M10 x 16 Z. white
BV185	BV018500	NR	Vite TCEI PG DIN 912 CI 8.8 M8 x 55 GEOMET 321A	Screw DIN 912 CI 8.8 M8 x 55 GEOMET 321A
BV186	BV018600	NR	Vite TCEI PG DIN 912 CI 12.9 M10 x 30 GEOMET 321A	Screw DIN 912 CI 12.9 M10 x 30 GEOMET 321A
BV187	BV018700	NR	Vite TCEI PG DIN 912 CI 12.9 M14 x 40 GEOMET 321A	Screw DIN 912 CI 12.9 M14 x 40 GEOMET 321A
BV188	BV018800	NR	Vite TE Tutto Filetto PG DIN 933 CI 8.8 M 12 x 60 Z.Bianca	Screw All Thread DIN 933 PG CI 8.8 M12 x 60 Z. white
BV189	BV018900	NR	Vite TE Tutto Filetto PG DIN 933 CI 8.8 M 12 x 55 Z.Bianca	Screw All Thread DIN 933 PG CI 8.8 M12 x 55 Z. white
BV190	BV019000	NR	Vite TE Tutto Filetto PG DIN 933 CI 8.8 M 12 x 50 Z.Bianca	Screw All Thread DIN 933 PG CI 8.8 M12 x 50 Z. white
BV191	BV019100	NR	Vite TE Tutto Filetto PG DIN 933 CI 8.8 M 16 x 50 Z.Bianca	Screw All Thread DIN 933 PG CI 8.8 M16 x 50 Z. white
BV192	BV019200	NR	Vite TE Tutto Filetto PG DIN 933 CI 8.8 M 16 x 55 Z.Bianca	Screw All Thread DIN 933 PG CI 8.8 M16 x 55 Z. white
BV193	BV019300	NR	Vite TE Parziale Filetto PG DIN 931 CI 8.8 M 10 x 55 Z.Bianca	Screw Partial Thread DIN 931 PG CI 8.8 M 10 x 55 Z. white
BV194	BV019400	NR	Vite TE Parziale Filetto PG DIN 931 CI 8.8 M 16 x 230 Z.Bianca	Screw Partial Thread DIN 931 PG CI 8.8 M 16 x 230 Z. white
BV195	BV019500	NR	Vite TE Parziale Filetto PG DIN 931 CI 8.8 M 6 x 50 Z.Bianca	Screw Partial Thread DIN 931 PG CI 8.8 M 6 x 50 Z. white
BV196	BV019600	NR	Vite TE Parziale Filetto PG DIN 931 CI 8.8 M 6 x 65 Z.Bianca	Screw Partial Thread DIN 931 PG CI 8.8 M 6 x 65 Z. white
BV197	BV019700	NR	Vite TE Parziale Filetto PG DIN 931 CI 8.8 M 8 x 45 Z.Bianca	Screw Partial Thread DIN 931 PG CI 8.8 M 8 x 45 Z. white



POS	Codice	U.M.	 Descrizione	 Description
BV198	BV019800	NR	Vite TE Parziale Filetto PG DIN 931 CI 8.8 M 8 x 55 Z.Bianca	Screw Partial Thread DIN 931 PG CI 8.8 M 8 x 55 Z. white
BV199	BV019900	NR	Vite TE Parziale Filetto PG DIN 931 CI 8.8 M 8 x 60 Z.Bianca	Screw Partial Thread DIN 931 PG CI 8.8 M 8 x 60 Z. white
BV200	BV020000	NR	Vite TE Tutto Filetto PG DIN 933 CI 10.9 M 16 x 40 Z.Bianca	Screw All Thread DIN 933 PG CI 10.9 M 16 x 40 Z. white
BV201	BV020100	NR	Vite TSPEI PG DIN 7991 CI 10.9 M16 x 45 Z.Bianca	TSPEI PG screw DIN 7991 CI 10.9 M16 x 45 Z. white
BV202	BV020200	NR	Vite TCEI PG DIN 912 CI 12.9 M3 x 12 ZINC. iridescente Fe/Zn5IVs	Screw DIN 912 CI 12.9 M3 x 12 ZINC. iridescente Fe/Zn5IVs
BV203	BV020300	NR	Vite TC Croce PG DIN 7985 CI 4.8 M M 3 x 5 Z.Bianca	Screw DIN 7985 CI 4.8 M M 3 x 5
BV204	BV020400	NR	Vite TC Croce PG DIN 7985 CI 4.8 M M 3 x 8 Z.Bianca	Screw DIN 7985 CI 4.8 M M 3 x 8
BV205	BV020500	NR	Vite TTQST DIN 603/555 CI 4.8 M 8 x 35 Z.Bianca	TTQST Screw DIN 603/555 CL 4.8 M 8 x 35 Z. White
BV206	BV020600	NR	Vite TC Croce PG DIN 7985 CI 4.8 M M 5 x 80 Z.Bianca	Screw DIN 7985 CI 4.8 M M 5 x 80
BV207	BV020700	NR	Vite TE Parziale Filetto PG DIN 931 CI 8.8 M 10 x 80 Z.Bianca	Screw Partial Thread DIN 931 PG CI 8.8 M 10 x 80 Z. white
BV208	BV020800	NR	Vite TE Tutto Filetto PG DIN 933 CI 8.8 M 16 x 35 Z.D.Bianca	Screw All Thread DIN 933 PG CI 8.8 M 16 x 35 ZD white
BV209	BV020900	NR	Vite TE Parziale Filetto PG DIN 931 CI 8.8 M 10 x 95 Z.Bianca	Screw Partial Thread DIN 931 PG CI 8.8 M 10 x 95 Z. white
BV210	BV021000	NR	Vite TE Tutto Filetto PG DIN 933 CI 8.8 M 6 x 14 Z.D.Bianca	Screw All Thread DIN 933 PG CI 8.8 M 6 x 14 ZD white
BV211	BV021100	NR	Vite TE Tutto Filetto PG DIN 933 CI 8.8 M 12 x 25 Z.D.Bianca	Screw All Thread DIN 933 PG CI 8.8 M 12 x 25 ZD white
BV212	BV021200	NR	Vite TE Tutto Filetto PG DIN 933 CI 8.8 M 4 x 14 Z.D.Bianca	Screw All Thread DIN 933 PG CI 8.8 M 4 x 14 ZD white
BV213	BV021300	NR	Vite TE Tutto Filetto PG DIN 933 CI 8.8 M 16 x 60 Z.D.Bianca	Screw All Thread DIN 933 PG CI 8.8 M 16 x 60 ZD white
BV214	BV021400	NR	Vite TE Parziale Filetto PG DIN 931 CI 8.8 M 6 x 100 Z.Bianca	Screw Partial Thread DIN 931 PG CI 8.8 M 6 x 100 Z. white



POS	Codice	U.M.	 Descrizione	 Description
BV215	BV021500	NR	Vite TE Parziale Filetto PG DIN 931 CI 10.9 M 16 x 110 Z.D.Bianca	Screw Partial Thread DIN 931 PG CI 10.9 M 16 x 110 ZD white
BV216	BV021600	NR	Vite TE Parziale Filetto PG DIN 931 CI 10.9 M 16 x 240 Z.D.Bianca	Screw Partial Thread DIN 931 PG CI 10.9 M 16 x 240 ZD white
BV217	BV021700	NR	Vite TSPEI PG DIN 7991 CI 10.9 M 8 x 30 Z.Bianca	TSPEI PG screw DIN 7991 CI 10.9 M8 x 30 Z. white
BV218	BV021800	NR	Vite TSPEI PG DIN 7991 CI 10.9 M 5 x 6 Z.Bianca	TSPEI PG screw DIN 7991 CI 10.9 M5 x 6 Z. white
BV219	BV021900	NR	Vite TSPEI PG DIN 7991 CI 10.9 M 5 x 70 Z.Bianca	TSPEI PG screw DIN 7991 CI 10.9 M5 x 70 Z. white
BV220	BV022000	NR	Vite TSPEI PG DIN 7991 CI 10.9 M 12 x 35 Z.Bianca	TSPEI PG screw DIN 7991 CI 10.9 M12 x 35 Z. white
BV221	BV022100	NR	Vite TCEI PG DIN 912 CI 12.9 M10 x 20 GEOMET 321A	Screw DIN 912 CI 12.9 M10 x 20 GEOMET 321A
BV222	BV022200	NR	Vite TCEI PG DIN 912 CI 12.9 M8 x 90 GEOMET 321A	Screw DIN 912 CI 12.9 M8 x 90 GEOMET 321A
BV223	BV022300	NR	Vite TCEI PG DIN 912 CI 12.9 M3 x 5 ZINC.	Screw DIN 912 CI 12.9 M3 x 5 ZINC.
BV224	BV022400	NR	Vite TBEI PG ISO 7380 CI 10.9 M 8 x 22 Z.Bianca	Hex socket screw ISO 7380 PG CI 10.9 M 8 x 22 Z. white
BV225	BV022500	NR	Vite TE Parziale Filetto PG DIN 931 CI 8.8 M 10 x 100 Z.Bianca	Screw Partial Thread DIN 931 PG CI 8.8 M 10 x 100 Z. white
BV226	BV022600	NR	Vite TE Parziale Filetto PG DIN 931 CI 8.8 M 10 x 110 Z.Bianca	Screw Partial Thread DIN 931 PG CI 8.8 M 10 x 110 Z. white
BV227	BV022700	NR	Vite TE Tutto Filetto PG DIN 933 CI 10.9 M 12 x 45 Z.D.Bianca	Screw All Thread DIN 933 PG CI 10.9 M 12 x 45 ZD white
BV228	BV022800	NR	Vite TE Tutto Filetto PG DIN 933 CI 10.9 M 14 x 35 Z.D.Bianca	Screw All Thread DIN 933 PG CI 10.9 M 14 x 35 ZD white
BV229	BV022900	NR	Vite TSPEI PG DIN 7991 CI 10.9 M 12 x 30 Z.Bianca	TSPEI PG screw DIN 7991 CI 10.9 M12 x 30 Z. white
BV230	BV023000	NR	Vite TE flangiata Tutto Filetto PG DIN 6921 CI 8.8 M 5 x 12 Zinconickel nero +sigillante	Flange Screw All Thread DIN 6921 PG CI 8.8 M 5 x 12 Zincnickel black +sealant

POS	Codice	U.M.	 Descrizione	 Description
BV231	BV023100	NR	Vite TE flangiata Tutto Filetto PG DIN 6921 CI 8.8 M 6 x 16 Zinconickel nero +sigillante	Flange Screw All Thread DIN 6921 PG CI 8.8 M 6 x 16 Zincnickel black +sealant
BV232	BV023200	NR	Vite TE Tutto Filetto PG DIN 933 CI 8.8 M 5 x 25 Z.D.Bianca	Screw All Thread DIN 933 PG CI 8.8 M 5 x 25 ZD white
BV233	BV023300	NR	Vite TE Tutto Filetto PG DIN 933 CI 8.8 M 8 x 130 Z.D.Bianca	Screw All Thread DIN 933 PG CI 8.8 M 8 x 130 ZD white
BV234	BV023400	NR	Vite TBEI PG ISO 7380 CI 10.9 M 8 x 22 Z.Bianca	Hex socket screw ISO 7380 PG CI 10.9 M 8 x 22 Z. white
BV235	BV023500	NR	Vite TE Tutto Filetto PG DIN 933 CI 10.9 M 16 x 35 Z.D.Bianca	Screw All Thread DIN 933 PG CI 10.9 M 16 x 35 ZD white
BV236	BV023600	NR	Vite TE Parziale Filetto PG DIN 931 CI 8.8 M 6 x 45 Z.Bianca	Screw Partial Thread DIN 931 PG CI 8.8 M 6 x 45 Z. white
BV237	BV023700	NR	Vite TE Tutto Filetto PG DIN 933 CI 10.9 M 12 x 30 Z.D.Bianca	Screw All Thread DIN 933 PG CI 10.9 M 12 x 30 ZD white



POS	Codice	U.M.	 Descrizione	 Description
RB1	RB000100	NR	DADO PER OGIVA Ø=12	NUT FOR OGIVA Ø = 12
RD1	RD000100	NR	RACCORDO CORPO A "T" EO F(DKOL)-M-M 8L	FITTING BODY A "T" EO F (DKOL) M-M-8L
RD2	RD000200	NR	RACCORDO CORPO A "T" EO F(DKOL)-M-M 10L	FITTING BODY A "T" EO F (DKOL) M-M-10L
RD3	RD000300	NR	RACCORDO CORPO A "T" EO F(DKOL)-M-M 12L	FITTING BODY A "T" EO F (DKOL) M-M-12L
RD4	RD000400	NR	RACCORDO CORPO A "T" EO F(DKOL)-M-M 15L	FITTING BODY A "T" EO F (DKOL) M-M-15L
RD5	RD000500	NR	RACCORDO CORPO A "T" EO M-F(DKOL)-M 10L	FITTING BODY A "T" EO M-F (DKOL) M-10L
RD6	RD000600	NR	RACCORDO CORPO A "T" EO M-F(DKOL)-M 12L	FITTING BODY A "T" EO M-F (DKOL) M-12L
RD7	RD000700	NR	RACCORDO CORPO A "T" EO 8L M 14*1.5	FITTING BODY A "T" EO 8L M 14 * 1.5
RD8	RD000800	NR	RACCORDO CORPO A "T" EO 10L M 16*1.5	FITTING BODY A "T" M 10L EO 16 * 1.5
RD9	RD000900	NR	RACCORDO CORPO A "T" EO 28L M 36*2	FITTING BODY A "T" M 28L EO 36 * 2
RD10	RD001000	NR	RACCORDO CORPO A "T" EO 28L M 36*2	FITTING BODY A "T" EO M-F (DKOL) M-10L
RD11	RD001100	NR	RACCORDO CORPO A "T" EO M-F(DKOL)-M 10L	FITTING BODY A "T" EO M-F (DKOL) M-10L
RG1	RG000100	NR	RACCORDO CORPO A GOMITO 10L MASCH.-FEMM. DKOL	ELBOW FITTING BODY 10L Masch.-FEMM. DKOL
RG2	RG000200	NR	RACCORDO CORPO A GOMITO 12L MASCH.-FEMM. DKOL	ELBOW FITTING BODY 12L Masch.-FEMM. DKOL
RG3	RG000300	NR	RACCORDO CORPO A GOMITO 20S MASCHIO-FEMMINA DKOS	20S BODY FITTING ELBOW MALE-FEMALE DKOS
RG4	RG000400	NR	RACCORDO CORPO A GOMITO 28L MASCHIO-FEMMINA DKOL	28L BODY FITTING ELBOW MALE-FEMALE DKOL
RG5	RG000500	NR	RACCORDO A L MASCHIO-FEMMINA 1/8	BODY 90 ° M / F 1/8 "



POS	Codice	U.M.	 Descrizione	 Description
RN1	RN000100	NR	RACCORDO CORPO D'ESTREMITA' TENUTA ED 8L * 3/8 GAS *K*	END FITTING WITH SEAL ED 8L * 3/8 GAS * K *
RN2	RN000200	NR	RACCORDO CORPO D'ESTREMITA' TENUTA ED 12L * 3/8 GAS *K*	END FITTING WITH SEAL ED 12L * 3/8 GAS * K *
RN3	RN000300	NR	RACCORDO CORPO D'ESTREMITA' TENUTA ED 10L * 3/8 GAS *K*	FITTING END OF BODY 'AND SEAL 10L * 3/8 GAS * K *
RN4	RN000400	NR	RACCORDO CORPO D'ESTREMITA' TENUTA ED 8L * 1/4 GAS *K*	END FITTING WITH SEAL ED 8L * 1/4 GAS * K *
RN5	RN000500	NR	RACCORDO CORPO D'ESTREMITA' TENUTA ED 10L * 1/4 GAS *K*	FITTING END OF BODY 'AND SEAL 10L * 1/4 GAS * K *
RN6	RN000600	NR	RACCORDO CORPO D'ESTREMITA' TENUTA ED 12L * 1/4 GAS	FITTING END OF BODY 'AND SEAL 12L * 1/4 GAS
RN7	RN000700	NR	RACCORDO NIPLES GAS CON.- GAS CON. 1/4" * 1/4"	FITTING
RN8	RN000800	NR	RACCORDO CORPO D'ESTREMITA' TENUTA ED 15L * 1/2 GAS *K*	END FITTING WITH SEAL ED 15L * 1/2 * K * GAS
RN9	RN000900	NR	RACCORDO CORPO D'ESTREMITA' TENUTA ED 10L * 1/2 GAS *K*	FITTING END OF BODY 'AND SEAL 10L * 1/2 * K * GAS
RN10	RN001000	NR	RACCORDO CORPO D'ESTREMITA' TENUTA ED 15L * 3/4 GAS *K*	END FITTING WITH SEAL ED 15L * 3/4 GAS * K *
RN11	RN001100	NR	RACCORDO CORPO D'ESTREMITA' TENUTA ED 12L * 1/2 GAS *K*	END FITTING WITH SEAL ED 12L * 1/2 GAS * K *
RN12	RN001200	NR	RACCORDO CORPO D'ESTR. TENUTA ED 8L * 1/2 GAS	END FITTING WITH SEAL ED 8L * 1/2 GAS
RN13	RN001300	NR	RACCORDO CORPO D'ESTR. TENUTA ED 8L * 3/4 GAS	CONNECTOR BODY OF EXTR. SEAL AND 8L * 3/4 GAS
RN14	RN001400	NR	RACCORDO CORPO D'ESTR. TENUTA ED 12L * 3/4 GAS	CONNECTOR BODY OF EXTR. SEAL AND 12L * 3/4 GAS
RN15	RN001500	NR	RACCORDO CORPO D'ESTR. TENUTA ED 15L * 3/8 GAS	END FITTING WITH SEAL ED 15L * 3/8 GAS
RN16	RN001600	NR	RACCORDO CORPO D'ESTR. TENUTA ED 22L * 3/4 GAS	END FITTING WITH SEAL ED 22L * 3/4 GAS

POS	Codice	U.M.	 Descrizione	 Description
RN17	RN001700	NR	RACCORDO CORPO D'ESTR. TENUTA ED 28L * 3/4" GAS	END FITTING WITH SEAL ED 28L * 3/4 BSP
RN18	RN001800	NR	RACCORDO CORPO D'ESTR. TENUTA ED 20S * 3/4 GAS	CONNECTOR BODY OF EXTR. SEAL AND 20S * 3/4 GAS
RN19	RN001900	NR	RACCORDO CORPO D'ESTREMITA' 8L * M 12X1.5 ED	END FITTING 8L * M 12x1.5 ED
RN20	RN002000	NR	RACCORDO CORPO D'ESTREMITA' 8L * M 14X1.5 ED	FITTING END OF BODY 'AND 8L * M 14x1.5
RN21	RN002100	NR	RACCORDO CORPO D'ESTREMITA' 10L * M 18X1.5 ED	END FITTING 10L * M 18x1.5
RN22	RN002200	NR	RACCORDO CORPO D'ESTR. TENUTA ED 15L * M 18X1.5	CONNECTOR BODY OF EXTR. SEAL AND 15L * M 18x1.5
RN23	RN002300	NR	RACCORDO CORPO D'ESTR. TENUTA ED 15L * M 22X1.5	END FITTING WIHT SEAL ED 15L * M 22x1.5
RN24	RN002400	NR	RACCORDO CORPO D'ESTR. TENUTA ED 22L * M26X1.5	CONNECTOR BODY OF EXTR. SEAL AND 22L * M26x1.5
RN25	RN002500	NR	RACCORDO CORPO D'ESTR. TENUTA ED 20S * M27X2	CONNECTOR BODY OF EXTR. SEAL AND 20S * M27X2
RN26	RN002600	NR	RACCORDO CORPO D'ESTR. 8L * 9/16-18 UNF-2A	END FITTING 8L * 9/16-18 UNF-2A
RN27	RN002700	NR	RACCORDO CORPO D'ESTR. 12L * 3/4 -16 UNF-2A	END FITTING 12L * 3/4 -16 UNF-2A
RN28	RN002800	NR	RACCORDO CORPO D'ESTR. 20S * 1.5/16 -12 UN-2A	END FITTING 20S * 1.5/16 -12 UN-2A
RN29	RN002900	NR	RACCORDO CORPO D'ESTR. TENUTA ED 22L * M26X1.5	END FITTING WITH SEAL ED 22L * M26x1.5
RN30	RN003000	NR	RACCORDO CORPO D'ESTR. TENUTA ED 22L * M26X1.5	END FITTING WITH SEAL ED 22L * M26x1.5
RN31	RN003100	NR	RACCORDO CORPO D'ESTREMITA' TENUTA ED 6L * 1/4 GAS *K*	END FITTING WITH SEAL 1/4 BSPP 6L
RN32	RN003200	NR	RACCORDO CORPO D'ESTREMITA' TENUTA ED 8L * 3/8 GAS *K*	END FITTING WITH SEAL ED 8L * 3/8 GAS * K *
RO1	RO000100	NR	OGIVA PER TUBO Ø=12	OGIVE FOR TUBE Ø = 12

POS	Codice	U.M.	 Descrizione	 Description
RR1	RR000100	NR	RONDELLA RAME 1/4	COPPER WASHER 1/4
RR2	RR000200	NR	RONDELLA BONDED GAS 3/8" *K*	BONDED WASHER GAS 3/8 " * K *
RR3	RR000300	NR	RONDELLA BONDED METRICA 12 *K*	METRIC BONDED WASHER 12 * K *
RR4	RR000400	NR	RONDELLA BONDED GAS 1/4" *K*	BONDED WASHER GAS 1/4 " * K *
RR5	RR000500	NR	RONDELLA BONDED GAS 1/2" *K*	BONDED WASHER GAS 1/2 " * K *
RR6	RR000600	NR	RONDELLA RAME 3/8	COPPER WASHER 3/8
RR7	RR000700	NR	RONDELLA BONDED GAS 1/8" *K*	BONDED WASHER GAS 1/8 " * K *
RR8	RR000800	NR	RONDELLA BONDED GAS 1" *K*	BONDED WASHER GAS 1 " * K *
RR9	RR000900	NR	RONDELLA BONDED GAS 3/4" *K*	BONDED WASHER GAS 3/4 " * K *
RR10	RR001000	NR	RONDELLA BONDED GAS 1.1/4"	BONDED WASHER GAS 1.1 / 4 "
RR11	RR001100	NR	RONDELLA RAME 1/8	COPPER WASHER 1/8
RR12	RR001200	NR	RONDELLA RAME 1/2	COPPER WASHER 1/2
RS1	RS000100	NR	COPPIA SEMIFLANGE SAE 6000 3/4"	PAIR 6000 SAE flange halves 3/4 "
RS2	RS000200	NR	RACC.M 20S(M30x2) - ED M 1"5/16 UNF H=33	FITTING M 20S (M30x2) - ED M 1 "5/16 UNF H = 33
RS3	RS000300	NR	RIDUZIONE M-F GAS 1" * 1/2"	REDUCING GAS M-F 1 " * 1/2"
RS4	RS000400	NR	RACCORDO COLONNETTA M15L - 3/8" GAS H=50	COLUMN CONNECTION M15L - 3/8 "GAS H = 50
RS5	RS000500	NR	RACCORDO COLONNETTA M15L - 3/8" GAS H=96	COLUMN CONNECTION M15L - 3/8 "GAS H = 96
RS6	RS000600	NR	CODOLO M1/4" ED X FG 8L (M14X1.5)	FITTING M1 / 4 "X AND FG 8L (M14X1.5)

POS	Codice	U.M.	 Descrizione	 Description
RS7	RS000700	NR	RIDUZIONE M-F GAS 1" * 1/2"	REDUCING GAS M-F 1 " * 1/2"
RS8	RS000800	NR	RACCORDO CODOLO D' ESTR. FEM. DKO 12I*3/8 GAS ED	END FITTING FEM. DKO 12I*3/8 GAS ED
RT1	RT000100	NR	TAPPO MASCHIO TE GAS 3/8" SVASATO 60° *K*	SCREW EYE FOR GAS 1/2 "H = 50
RT2	RT000200	NR	TAPPO MASCHIO ESAGONO INTERNO GAS 1/4" SVASATO 60° *K*	MALE PLUG GAS INTERNAL HEX 1/4 "FLARE 60 ° * K *
RT3	RT000300	NR	TAPPO MASCHIO TE GAS 1/2" SVASATO 60° *K*	MALE PLUG TE GAS 1/2 "FLARE 60 ° * K *
RT4	RT000400	NR	TAPPO MASCHIO TE GAS 1/4" SVASATO 60° *K*	MALE PLUG TE GAS 1/4 "FLARE 60 ° * K *
RT5	RT000500	NR	TAPPO MASCHIO ESAGONO INTERNO GAS 3/8" SVASATO 60° *K*	MALE PLUG GAS INTERNAL HEX 3/8 "FLARE 60 ° * K *
RT6	RT000600	NR	TAPPO MASCHIO ESAGONO INTERNO GAS 1" SVASATO 60° *K*	MALE PLUG GAS INTERNAL HEX 1 "FLARE 60 ° * K *
RV1	RV000100	NR	VITE PER OCCHIO GAS 1/4" H=29 *K*	SCREW EYE FOR GAS 1/4 "H = 29 * K *
RV2	RV000200	NR	VITE PER OCCHIO DOPPIA GAS 3/8"	SCREW EYE DOUBLE FOR GAS 3/8 "
RV3	RV000300	NR	VITE PER OCCHIO GAS 1/2" H= 50	SCREW EYE FOR GAS 1/2 "H = 50
RV4	RV000400	NR	VITE PER OCCHIO DOPPIA GAS 1/4"	DOUBLE EYE SCREW FOR GAS 1/4"
RV5	RV000500	NR	VITE PER OCCHIO GAS 3/8"	SCREW EYE FOR GAS 3/8"



An Oshkosh Corporation Company

JLG Industries, Inc.  
1 JLG Drive  
McConnellsburg PA. 17233-  
9533  
USA

(717) 485-5161

(717) 485-6417

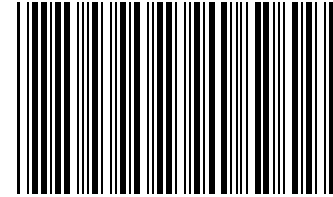

3121604

## JLG Worldwide Locations

JLG Industries (Australia)  
P.O. Box 5119  
11 Bolwarra Road  
Port Macquarie  
N.S.W. 2444  
Australia

+61 2 65 811111

+61 2 65 810122

JLG Latino Americana Ltda.  
Rua Eng. Carlos Stevenson,  
80-Suite 71  
13092-310 Campinas-SP  
Brazil

+55 19 3295 0407

+55 19 3295 1025

JLG Industries (UK) Ltd  
Bentley House  
Bentley Avenue  
Middleton  
Greater Manchester  
M24 2GP - England

+44 (0)161 654 1000

+44 (0)161 654 1001

JLG France SAS  
Z.I. de Fauillet  
47400 Tonneins  
France

+33 (0)5 53 88 31 70

+33 (0)5 53 88 31 79

JLG Deutschland GmbH  
Max-Planck-Str. 21  
D - 27721 Ritterhude - Ihlpohl  
Germany

+49 (0)421 69 350 20

+49 (0)421 69 350 45

JLG Equipment Services Ltd.  
Rm 1107 Landmark North  
39 Lung Sum Avenue  
Sheung Shui N. T.  
Hong Kong

(852) 2639 5783

(852) 2639 5797

JLG Industries (Italia) s.r.l.  
Via Po. 22  
20010 Pregnana Milanese - MI  
Italy

+39 029 359 5210

+39 029 359 5845

Oshkosh - JLG Singapore T. E. P. Ltd.  
29 Tuas Ave 4  
Jurong Industrial Estate  
639379  
Singapore

+65-6591-9030

+65-6591-9031

Plataformas Elevadoras  
JLG Iberica, S.L.  
Trapadella, 2  
P.I. Castellbisbal Sur  
08755 Castellbisbal, Barcelona  
Spain

+34 93 772 4700

+34 93 771 1762

JLG Sverige AB  
Enkopingsvagen 150  
Box 704  
SE - 176 27 Jarfalla  
Sweden

+46 (0)850 659 500

+46 (0)850 659 534

[www.jlg.com](http://www.jlg.com)