



An Oshkosh Corporation Company

---

# ***Illustrated Parts Manual***

## ***Compact Crawler***

***X17JA/3***

***X17JA/4***

***X17JP/2***

***X17JP/3***

***X17JP/4***

***X500AJ/2***



***X500AJ/3***



***X500AJ/4***







**3121613**  
April 18, 2023 - Rev I



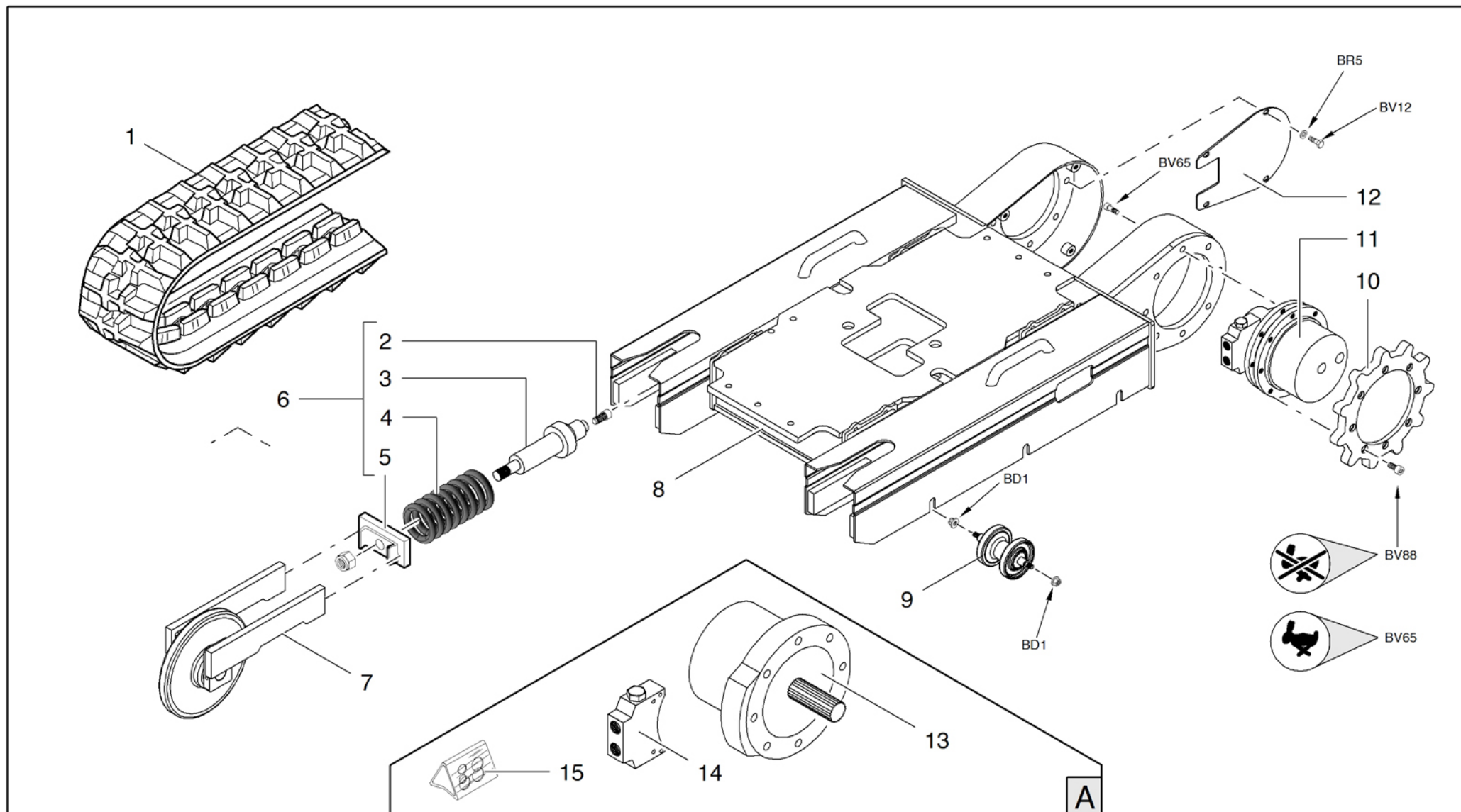



 SOTTOCARRO CINGOLATO  
 TRACKED UNDERCARRIAGE  
 CHENILLARD





 RAUPENFAHRWERK  
 CARRO DE ORUGAS









Main color codes:  J1 - JLG Cream,  J2 - JLG Orange,  C4 - Green



 SOTTOCARRO CINGOLATO  
 TRACKED UNDERCARRIAGE  
 CHENILLARD

 RAUPENFAHRWERK  
 CARRO DE ORUGAS



POS	Codice	 Descrizione	 Description	 Designation	 Benennung	 Descripción
1	053715L0	CINGOLO IN GOMMA BASSO PROFILO NERO	RUBBER TRACK LOW PROFILE BLACK	CHENILLE EN CAOUTCHOUC	GUMMIRAUPE	ORUGA DE GOMA
1	053715LB	CINGOLO IN GOMMA BASSO PROFILO ANTITRACCIA	RUBBER TRACK LOW PROFILE NO MARKING	CHENILLE BLANCHE CAOUTCHOUC	GUMMIRAUPE	ORUGA BLANCA DE GOMA
2	03149200	VALVOLA IDRAULICA	HYDRAULIC VALVE	VALVE HYDRAULIQUE	HYDRAULIKVENTIL	VÁLVULA HIDRÁULICA
3	10681670	CILINDRO	CYLINDER	VÉRIN	ZYLINDER	CILINDRO
4	03024800	MOLLA	SPRING	RESSORT	FEDER	MUELLE
5	34719500	PIATTO	PLATE	PLATEAU	PLATTE	PLACA
6	147534Y1	SUPPORTO TENDICINGOLO	IDLER SUPPORT	SUPPORT TENDEUR CHENILLE	KETTEHSPANNER-HALTER	SOPORTE TENSOR ORUGA
7	153937H2	RUOTA TENDICINGOLO	IDLER WHEEL	ROUE TENDEUR DE CHENILLE	RAUPENSPANNRAD	RUEDA TENSOR ORUGA
8	156030H2	SOTTOCARRO CINGOLATO	TRACKED UNDERCARRIAGE	CHENILLARD	RAUPENFAHRWERK	CARRO CON ORUGAS
9	153515H2	RULLO INFERIORE	CARRIER ROLLER	ROULEAU INFÉRIEUR	UNTERE ROLLE	RODILLO INFERIOR
10	055707H2	RUOTA DI TRAZIONE	SPROCKET WHEEL	ROUE DE TRACTION	ANTRIEBSRAD	RUEDA DE ARRASTRE
11	267525H2	MOTORIDUTTORE 700C2K I:32 + MAG12 VP AUTO2SPEED CON FRENO	GEAR MOTOR 700C2K I: 32 + MAG12 VP AUTO2SPEED WITH BRAKE	MOTORÉDUCTEUR	GETRIEBEMOTOR	MOTORREDUCTOR
12	054868H2	COPERCHIO 2 VELOCITÀ	COVER HIGH SPEED	COUVERCLE	TAPA	DEKSEL

Main color codes:  J1 - JLG Cream,  J2 - JLG Orange,  C4 - Green

-  ALLARGAMENTO IDRAULICO
-  HYDRAULIC EXTENSION
-  ECARTEMENT HYDRAULIQUE

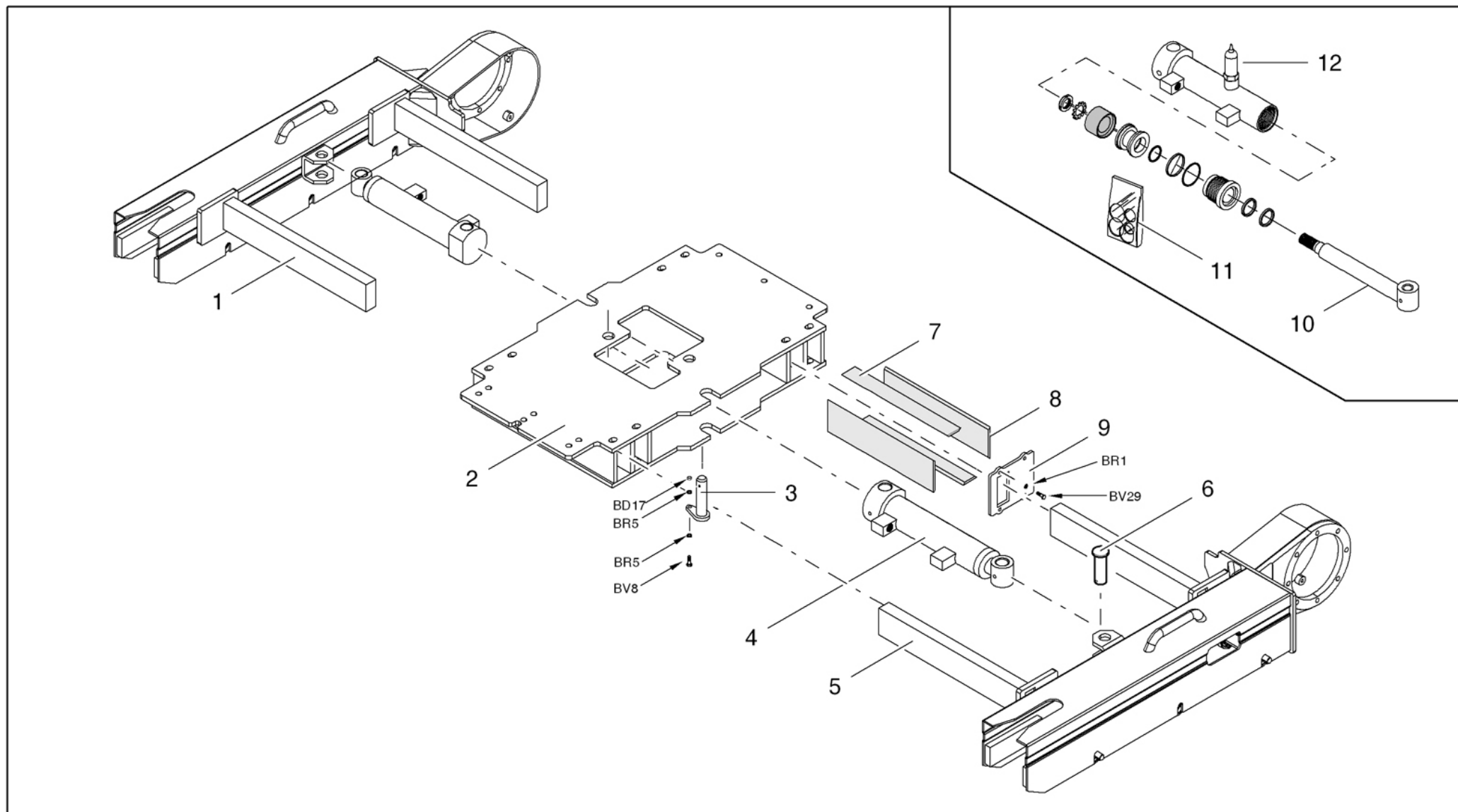
HYDR. SPURWEITENVER STELLEINRICHTUNG   
 EXTENSION HIDRAULICA 











Main color codes:  J1 - JLG Cream,  J2 - JLG Orange,  C4 - Green



 ALLARGAMENTO IDRAULICO

 HYDRAULIC EXTENSION



 ECARTEMENT HYDRAULIQUE
HYDR. SPURWEITENVER STELLEINRICHTUNG EXTENSION HIDRAULICA 

POS	Codice	 Descrizione	 Description	 Designation	 Benennung	 Descripción
1	356030H2	ASSIEME LONGHERONE DESTRO 2 VELOCITÀ	RIGHT SIDE FRAME ASSEMBLY HIGH SPEED	ENSEMBLE CHÂSSIS LATÉRAL LONGERON DROIT	LÄNGSTRÄGERBAUG RUPPE RECHTS	CONJUNTO LARGUERO DERECHO
2	353853H2	STRUTTURA	STRUCTURE	STRUCTURE	STRUKTUR	ESTRUCTURA
3	05419700	SPINA	PIN	CHEVILLE	STIF	CLAVIJA
4	17178100	CILINDRO	CYLINDER	CYLINDER	ZYLINDER	CILINDRO
4	171781H2	CILINDRO	CYLINDER	CYLINDER	ZYLINDER	CILINDRO
5	356031H2	ASSIEME LONGHERONE SINISTRO 2 VELOCITÀ	LEFT SIDE FRAME ASSEMBLY HIGH SPEED	ENSEMBLE CHÂSSIS LATÉRAL LONG. GAUCHE	LÄNGSTRÄGERBAUG RUPPE LINKS	CONJUNTO LARGUERO IZQUIERDO
6	04256300	SPINA	PIN	CHEVILLE	STIFT	CLAVIJA
7	04624900	GUIDA ALLARGAMENTO	EXPANSION GUIDE	GLISSIÈRE ÉLARGISSEMENT	FÜHRUNGSVERBREIT ERUNG	GUÍA DE EXTENSIÓN
8	04624800	GUIDA ALLARGAMENTO	EXPANSION GUIDE	GLISSIÈRE ÉLARGISSEMENT	FÜHRUNGSVERBREIT ERUNG	GUÍA DE EXTENSIÓN
9	346108H2	COPERCHIO	COVER	COUVERCLE	DECKEL	TAPA
10	1717810002	STELO ALLARGAMENTO CARRO	ROD CYLINDER ENLARGEMENT	TIGE D'EXTENSION CAMION	VERLÄNGERUNGSST ANGE TRUCK	EXTENSION ROD TRUCK
11	1717810001	KIT GUARNIZIONI CILINDRO ALLARGAMENTO CARRO	ENLARGEMENT CYLINDER GASKET KIT	ÉLARGISSEMENT CAMION KIT CYLINDRE JOINT	ERWEITERUNG CYLINDER GASKET KIT TRUCK	PLIACIÓN DE JUNTAS CILINDRO TRUCK KIT
12	17329500	MICROINTERRUPTOR E ALLARGAMENTO CARRO N/O COMPLETO DI CAVO E CONNETTORE	WIDENING SYSTEM MICRO SWITCH N/O CONTACT WITH CABLE AND CONNECTOR	MICRO INTERRUPTEUR ELARGISSEMENT AVEC CABLE ET CONNECTEUR	MIKROSCHALTER SPURVERBREITERUN G MIT KABEL UND STECKER	MICROINTERRUPTOR ENSANCHAMIENTO CON CABLE Y CONECTOR



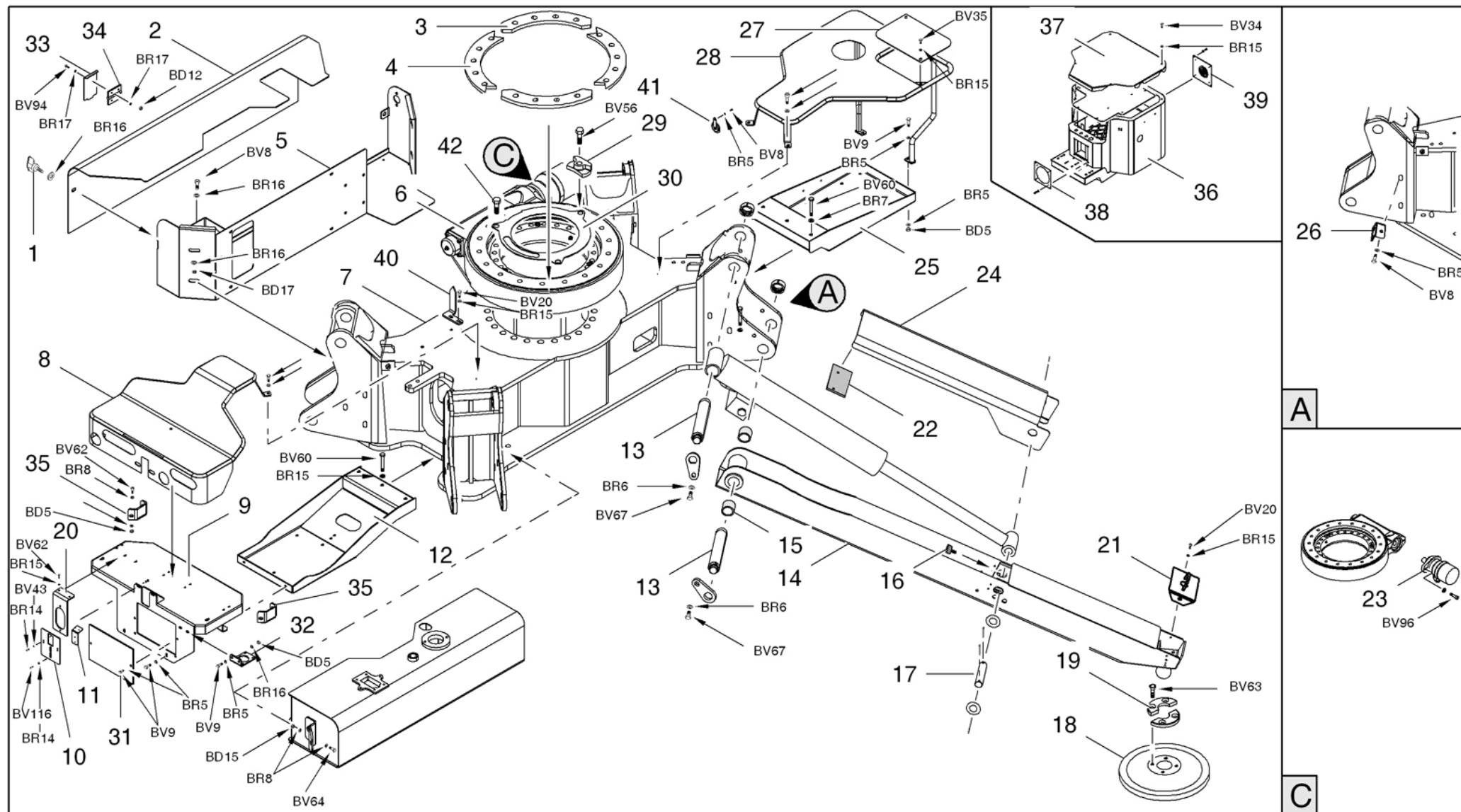

-  BASE TORRETTA
-  TURRET BASE
-  BASE TOURELLE



ARBEITSTURM   
 BASE TORRETTA GIRATORIA 



Main color codes:  J1 - JLG Cream,  J2 - JLG Orange,  C4 - Green

 BASE TORRETTA TURRET BASE BASE TOURELLEARBEITSTURM BASE TORRETTA GIRATORIA 



POS	Codice	 Descrizione	 Description	 Designation	 Benennung	 Descripción
1	05611000	GALLETTO	WING NUT	ECROU PAPILLON	FLÜGELMUTTER	TUERCA DE MARIPOSA
2	076839A1	COPERCHIO MK2 (DA C170000893)	COVER	COUVERCLE	ABDECKUNG	TAPA
2	076839A2	COPERCHIO MK2 (DA C170000893)	COVER	COUVERCLE	ABDECKUNG	TAPA
2	076839A3	COPERCHIO MK2 (DA C170000893)	COVER	COUVERCLE	ABDECKUNG	TAPA
2	076839A5	COPERCHIO MK2 (DA C170000893)	COVER	COUVERCLE	ABDECKUNG	TAPA
2	076839A6	COPERCHIO MK2 (DA C170000893)	COVER MK2 (FROM C170000893)	COUVERCLE	ABDECKUNG	TAPA
2	076839A7	COPERCHIO MK2 (DA C170000893)	COVER	COUVERCLE	ABDECKUNG	TAPA
2	076839A9	COPERCHIO MK2 (DA C170000893)	COVER	COUVERCLE	ABDECKUNG	TAPA
2	076839AG	COPERCHIO MK2 (DA C170000893)	COVER	COUVERCLE	ABDECKUNG	TAPA
2	076839B1	COPERCHIO MK2 (DA C170000893)	COVER	COUVERCLE	ABDECKUNG	TAPA
2	076839B9	COPERCHIO MK2 (DA C170000893)	COVER	COUVERCLE	ABDECKUNG	TAPA
2	076839BC	COPERCHIO MK2 (DA C170000893)	COVER	COUVERCLE	ABDECKUNG	TAPA
2	076839BP	COPERCHIO MK2 (DA C170000893)	COVER	COUVERCLE	ABDECKUNG	TAPA
2	076839C4	COPERCHIO MK2 (DA C170000893)	COVER	COUVERCLE	ABDECKUNG	TAPA
2	076839D5	COPERCHIO MK2 (DA C170000893)	COVER	COUVERCLE	ABDECKUNG	TAPA
2	076839D7	COPERCHIO MK2	COVER	COUVERCLE	ABDECKUNG	TAPA
2	076839DI	COPERCHIO MK2 (DA C170000893)	COVER	COUVERCLE	ABDECKUNG	TAPA

Main color codes:  J1 - JLG Cream,  J2 - JLG Orange,  C4 - Green











 BASE TORRETTA TURRET BASE BASE TOURELLEARBEITSTURM BASE TORRETTA GIRATORIA 

POS	Codice	 Descrizione	 Description	 Designation	 Benennung	 Descripción
2	076839DT	COPERCHIO MK2 (DA C170000893)	COVER	COUVERCLE	ABDECKUNG	TAPA
2	076839EM	COPERCHIO MK2 (DA C170000893)	COVER	COUVERCLE	ABDECKUNG	TAPA
2	076839EW	COPERCHIO MK2 (DA C170000893)	COVER MK2 (FROM C170000893)	COUVERCLE	ABDECKUNG	TAPA
2	076839GB	COPERCHIO MK2 (DA C170000893)	COVER	COUVERCLE	ABDECKUNG	TAPA
2	076839H1	COPERCHIO MK2 (DA C170000893)	COVER	COUVERCLE	ABDECKUNG	TAPA
2	076839H2	COPERCHIO MK2 (DA C170000893)	COVER (FROM C170000893)	COUVERCLE (C170000893)	ABDECKUNG (C170000893)	TAPA (C170000893)
2	076839J2	COPERCHIO MK2 (DA C170000893)	COVER MK2 (FROM C170000893)	COUVERCLE	ABDECKUNG	TAPA
2	37228500	COPERCHIO	COVER	COUVERCLE	DECKEL	TAPA
2	372285A1	COPERCHIO	COVER	COUVERCLE	DECKEL	TAPA
2	372285A7	COPERCHIO	COVER	COUVERCLE	DECKEL	TAPA
2	372285B1	COPERCHIO	COVER	COUVERCLE	DECKEL	TAPA
2	372285J0	SALDATO COPERCHIO COMPONENTI ELETTRICI	WELDED COVER ELECTRICAL COMPONENTS	COUVERCLE	DECKEL	TAPA
3	069349Y1	SPESSORE	THICKNESS	CALE	STÄRKE	ESPEJOR
4	069348Y1	SPESSORE	THICKNESS	CALE	STÄRKE	ESPEJOR
5	371389A1	SCATOLA COMPONENTI ELETTRICI SALDATA	BOX ELECTRONIC COMPONENTS WELDED	COMPOSANTS ÉLECTRIQUES BOX	BOX ELEKTROKOMPONEN TEN	CAJA DE COMPONENTES ELÉCTRICOS
5	371389A7	SCATOLA COMPONENTI ELETTRICI SALDATA	BOX ELECTRONIC COMPONENTS WELDED	COMPOSANTS ÉLECTRIQUES BOX	BOX ELEKTROKOMPONEN TEN	CAJA DE COMPONENTES ELÉCTRICOS
5	371389B1	SCATOLA COMPONENTI ELETTRICI SALDATA	BOX ELECTRONIC COMPONENTS WELDED	COMPOSANTS ÉLECTRIQUES BOX	BOX ELEKTROKOMPONEN TEN	CAJA DE COMPONENTES ELÉCTRICOS
5	371389J0	SCATOLA ELETTRICA	ELECTRIC BOX	BOÎTE ÉLECTRIQUE	ELEKTROGEHÄUSE	CAJA ELÉCTRICA





Main color codes:  J1 - JLG Cream,  J2 - JLG Orange,  C4 - Green



 BASE TORRETTA TURRET BASE BASE TOURELLEARBEITSTURM BASE TORRETTA GIRATORIA 

POS	Codice	 Descrizione	 Description	 Designation	 Benennung	 Descripció
5	376840A1	SCATOLA COMPONENTI ELETTRICI MK2 (DA C170000893)	ELECTRIC COMPONENTS BOX MK2 (FROM C170000893)	BOÎTE COMPOSANTS ÉLECTRIQUES MK2 (FROM C170000893)	ELEKTROKOMPONEN TENGEHÄUSE MK2 (FROM C170000893)	CAJA DE COMPONENTES ELÉCTRICOS MK2 (FROM C170000893)
5	376840A2	SCATOLA COMPONENTI ELETTRICI MK2 (DA C170000893)	ELECTRIC COMPONENTS BOX MK2 (FROM C170000893)	BOÎTE COMPOSANTS ÉLECTRIQUES MK2 (FROM C170000893)	ELEKTROKOMPONEN TENGEHÄUSE MK2 (FROM C170000893)	CAJA DE COMPONENTES ELÉCTRICOS MK2 (FROM C170000893)
5	376840A3	SCATOLA COMPONENTI ELETTRICI MK2 (DA C170000893)	ELECTRIC COMPONENTS BOX MK2 (FROM C170000893)	BOÎTE COMPOSANTS ÉLECTRIQUES MK2 (FROM C170000893)	ELEKTROKOMPONEN TENGEHÄUSE MK2 (FROM C170000893)	CAJA DE COMPONENTES ELÉCTRICOS MK2 (FROM C170000893)
5	376840A5	SCATOLA COMPONENTI ELETTRICI MK2 (DA C170000893)	ELECTRIC COMPONENTS BOX MK2 (FROM C170000893)	BOÎTE COMPOSANTS ÉLECTRIQUES MK2 (FROM C170000893)	ELEKTROKOMPONEN TENGEHÄUSE MK2 (FROM C170000893)	CAJA DE COMPONENTES ELÉCTRICOS MK2 (FROM C170000893)
5	376840A6	SCATOLA COMPONENTI ELETTRICI MK2 (DA C170000893)	ELECTRIC COMPONENTS BOX MK2 (FROM C170000893)	BOÎTE COMPOSANTS ÉLECTRIQUES MK2 (FROM C170000893)	ELEKTROKOMPONEN TENGEHÄUSE MK2 (FROM C170000893)	CAJA DE COMPONENTES ELÉCTRICOS MK2 (FROM C170000893)
5	376840A7	SCATOLA COMPONENTI ELETTRICI MK2 (DA C170000893)	ELECTRIC COMPONENTS BOX MK2 (FROM C170000893)	BOÎTE COMPOSANTS ÉLECTRIQUES MK2 (FROM C170000893)	ELEKTROKOMPONEN TENGEHÄUSE MK2 (FROM C170000893)	CAJA DE COMPONENTES ELÉCTRICOS MK2 (FROM C170000893)
5	376840A9	SCATOLA COMPONENTI ELETTRICI MK2 (DA C170000893)	ELECTRIC COMPONENTS BOX MK2 (FROM C170000893)	BOÎTE COMPOSANTS ÉLECTRIQUES MK2 (FROM C170000893)	ELEKTROKOMPONEN TENGEHÄUSE MK2 (FROM C170000893)	CAJA DE COMPONENTES ELÉCTRICOS MK2 (FROM C170000893)
5	376840AG	SCATOLA COMPONENTI ELETTRICI MK2 (DA C170000893)	ELECTRIC COMPONENTS BOX MK2 (FROM C170000893)	BOÎTE COMPOSANTS ÉLECTRIQUES MK2 (FROM C170000893)	ELEKTROKOMPONEN TENGEHÄUSE MK2 (FROM C170000893)	CAJA DE COMPONENTES ELÉCTRICOS MK2 (FROM C170000893)





Main color codes:  J1 - JLG Cream,  J2 - JLG Orange,  C4 - Green



 BASE TORRETTA TURRET BASE BASE TOURELLEARBEITSTURM BASE TORRETTA GIRATORIA 

POS	Codice	 Descrizione	 Description	 Designation	 Benennung	 Descripción
5	376840B1	SCATOLA COMPONENTI ELETTRICI MK2 (DA C170000893)	ELECTRIC COMPONENTS BOX MK2 (FROM C170000893)	BOÎTE COMPOSANTS ÉLECTRIQUES MK2 (FROM C170000893)	ELEKTROKOMPONEN TENGEHÄUSE MK2 (FROM C170000893)	CAJA DE COMPONENTES ELÉCTRICOS MK2 (FROM C170000893)
5	376840B9	SCATOLA COMPONENTI ELETTRICI MK2 (DA C170000893)	ELECTRIC COMPONENTS BOX MK2 (FROM C170000893)	BOÎTE COMPOSANTS ÉLECTRIQUES MK2 (FROM C170000893)	ELEKTROKOMPONEN TENGEHÄUSE MK2 (FROM C170000893)	CAJA DE COMPONENTES ELÉCTRICOS MK2 (FROM C170000893)
5	376840BC	SCATOLA COMPONENTI ELETTRICI MK2 (DA C170000893)	ELECTRIC COMPONENTS BOX MK2 (FROM C170000893)	BOÎTE COMPOSANTS ÉLECTRIQUES MK2 (FROM C170000893)	ELEKTROKOMPONEN TENGEHÄUSE MK2 (FROM C170000893)	CAJA DE COMPONENTES ELÉCTRICOS MK2 (FROM C170000893)
5	376840BP	SCATOLA COMPONENTI ELETTRICI MK2 (DA C170000893)	ELECTRIC COMPONENTS BOX MK2 (FROM C170000893)	BOÎTE COMPOSANTS ÉLECTRIQUES MK2 (FROM C170000893)	ELEKTROKOMPONEN TENGEHÄUSE MK2 (FROM C170000893)	CAJA DE COMPONENTES ELÉCTRICOS MK2 (FROM C170000893)
5	376840C4	SCATOLA COMPONENTI ELETTRICI MK2 (DA C170000893)	ELECTRIC COMPONENTS BOX MK2 (FROM C170000893)	BOÎTE COMPOSANTS ÉLECTRIQUES MK2 (FROM C170000893)	ELEKTROKOMPONEN TENGEHÄUSE MK2 (FROM C170000893)	CAJA DE COMPONENTES ELÉCTRICOS MK2 (FROM C170000893)
5	376840D5	SCATOLA COMPONENTI ELETTRICI MK2 (DA C170000893)	ELECTRIC COMPONENTS BOX MK2 (FROM C170000893)	BOÎTE COMPOSANTS ÉLECTRIQUES MK2 (FROM C170000893)	ELEKTROKOMPONEN TENGEHÄUSE MK2 (FROM C170000893)	CAJA DE COMPONENTES ELÉCTRICOS MK2 (FROM C170000893)
5	376840D7	SCATOLA COMPONENTI ELETTRICI MK2	ELECTRIC COMPONENTS BOX MK2	BOÎTE COMPOSANTS ÉLECTRIQUES MK2	ELEKTROKOMPONEN TENGEHÄUSE MK2	CAJA DE COMPONENTES ELÉCTRICOS MK2
5	376840DI	SCATOLA COMPONENTI ELETTRICI MK2 (DA C170000893)	ELECTRIC COMPONENTS BOX MK2 (FROM C170000893)	BOÎTE COMPOSANTS ÉLECTRIQUES MK2 (FROM C170000893)	ELEKTROKOMPONEN TENGEHÄUSE MK2 (FROM C170000893)	CAJA DE COMPONENTES ELÉCTRICOS MK2 (FROM C170000893)





Main color codes:  J1 - JLG Cream,  J2 - JLG Orange,  C4 - Green



 BASE TORRETTA TURRET BASE BASE TOURELLEARBEITSTURM BASE TORRETTA GIRATORIA 

POS	Codice	 Descrizione	 Description	 Designation	 Benennung	 Descripción
5	376840DT	SCATOLA COMPONENTI ELETTRICI MK2 (DA C170000893)	ELECTRIC COMPONENTS BOX MK2 (FROM C170000893)	BOÎTE COMPOSANTS ÉLECTRIQUES MK2 (FROM C170000893)	ELEKTROKOMPONEN TENGEHÄUSE MK2 (FROM C170000893)	CAJA DE COMPONENTES ELÉCTRICOS MK2 (FROM C170000893)
5	376840EM	SCATOLA COMPONENTI ELETTRICI MK2 (DA C170000893)	ELECTRIC COMPONENTS BOX MK2 (FROM C170000893)	BOÎTE COMPOSANTS ÉLECTRIQUES MK2 (FROM C170000893)	ELEKTROKOMPONEN TENGEHÄUSE MK2 (FROM C170000893)	CAJA DE COMPONENTES ELÉCTRICOS MK2 (FROM C170000893)
5	376840EW	SCATOLA COMPONENTI ELETTRICI MK2 (DA C170000893)	ELECTRIC COMPONENTS BOX MK2 (FROM C170000893)	BOÎTE COMPOSANTS ÉLECTRIQUES MK2 (FROM C170000893)	ELEKTROKOMPONEN TENGEHÄUSE MK2 (FROM C170000893)	CAJA DE COMPONENTES ELÉCTRICOS MK2 (FROM C170000893)
5	376840GB	SCATOLA COMPONENTI ELETTRICI MK2 (DA C170000893)	ELECTRIC COMPONENTS BOX MK2 (FROM C170000893)	BOÎTE COMPOSANTS ÉLECTRIQUES MK2 (FROM C170000893)	ELEKTROKOMPONEN TENGEHÄUSE MK2 (FROM C170000893)	CAJA DE COMPONENTES ELÉCTRICOS MK2 (FROM C170000893)
5	376840H1	SCATOLA COMPONENTI ELETTRICI MK2 (DA C170000893)	ELECTRIC COMPONENTS BOX MK2 (FROM C170000893)	BOÎTE COMPOSANTS ÉLECTRIQUES MK2 (FROM C170000893)	ELEKTROKOMPONEN TENGEHÄUSE MK2 (FROM C170000893)	CAJA DE COMPONENTES ELÉCTRICOS MK2 (FROM C170000893)
5	376840H2	SCATOLA COMPONENTI ELETTRICI MK2 (DA C170000893)	ELECTRIC COMPONENTS BOX MK2 (FROM C170000893)	BOÎTE COMPOSANTS ÉLECTRIQUES MK2 (FROM C170000893)	ELEKTROKOMPONEN TENGEHÄUSE MK2 (FROM C170000893)	CAJA DE COMPONENTES ELÉCTRICOS MK2 (FROM C170000893)
5	376840J2	SCATOLA COMPONENTI ELETTRICI MK2 (DA C170000893)	ELECTRIC COMPONENTS BOX MK2 (FROM C170000893)	BOÎTE COMPOSANTS ÉLECTRIQUES MK2 (FROM C170000893)	ELEKTROKOMPONEN TENGEHÄUSE MK2 (FROM C170000893)	CAJA DE COMPONENTES ELÉCTRICOS MK2 (FROM C170000893)
6	261191H2	RALLA	FIFTH WHEEL	COURONNE DENTÉE	DREHKRANZ	TEJUELO
7	371317H2	BASE PIATTAFORMA	PLATFORM BASE	BASE PLATEFORME	ARBEITSBÜHNENUNT ERGESTELL	BASE PLATAFORMA
8	371400A1	PROTEZIONE	PROTECTION	PROTECTION	SCHUTZ	PROTECCIÓN
8	371400A2	PROTEZIONE	PROTECTION	PROTECTION	SCHUTZ	PROTECCIÓN
8	371400A3	PROTEZIONE	PROTECTION	PROTECTION	SCHUTZ	PROTECCIÓN





Main color codes:  J1 - JLG Cream,  J2 - JLG Orange,  C4 - Green



 BASE TORRETTA TURRET BASE BASE TOURELLEARBEITSTURM BASE TORRETTA GIRATORIA 

POS	Codice	 Descrizione	 Description	 Designation	 Benennung	 Descripción
8	371400A5	PROTEZIONE	PROTECTION	PROTECTION	SCHUTZ	PROTECCIÓN
8	371400A6	PROTEZIONE	PROTECTION	PROTECTION	SCHUTZ	PROTECCIÓN
8	371400A7	PROTEZIONE	PROTECTION	PROTECTION	SCHUTZ	PROTECCIÓN
8	371400A9	PROTEZIONE	PROTECTION	PROTECTION	SCHUTZ	PROTECCIÓN
8	371400AG	PROTEZIONE	PROTECTION	PROTECTION	SCHUTZ	PROTECCIÓN
8	371400B1	PROTEZIONE	PROTECTION	PROTECTION	SCHUTZ	PROTECCIÓN
8	371400B9	PROTEZIONE	PROTECTION	PROTECTION	SCHUTZ	PROTECCIÓN
8	371400BC	PROTEZIONE	PROTECTION	PROTECTION	SCHUTZ	PROTECCIÓN
8	371400BP	PROTEZIONE	PROTECTION	PROTECTION	SCHUTZ	PROTECCIÓN
8	371400C4	PROTEZIONE	PROTECTION	PROTECTION	SCHUTZ	PROTECCIÓN
8	371400D5	PROTEZIONE	PROTECTION	PROTECTION	SCHUTZ	PROTECCIÓN
8	371400D7	PROTEZIONE	PROTECTION	PROTECTION	SCHUTZ	PROTECCIÓN
8	371400DI	PROTEZIONE	PROTECTION	PROTECTION	SCHUTZ	PROTECCIÓN
8	371400DT	PROTEZIONE	PROTECTION	PROTECTION	SCHUTZ	PROTECCIÓN
8	371400EM	PROTEZIONE	PROTECTION	PROTECTION	SCHUTZ	PROTECCIÓN
8	371400EW	PROTEZIONE	PROTECTION	PROTECTION	SCHUTZ	PROTECCIÓN
8	371400GB	PROTEZIONE	PROTECTION	PROTECTION	SCHUTZ	PROTECCIÓN
8	371400H1	PROTEZIONE	PROTECTION	PROTECTION	SCHUTZ	PROTECCIÓN
8	371400H2	PROTEZIONE	PROTECTION	PROTECTION	SCHUTZ	PROTECCIÓN
8	371400J2	PROTEZIONE	PROTECTION	PROTECTION	SCHUTZ	PROTECCIÓN
9	068863A1	LAMA DI FISSAGGIO	FIXING BLADE	LAME DE FIXAGE	BEFESTIGUNGSSCHIL D	LAMA FIJACIÓN
9	068863A2	LAMA DI FISSAGGIO	FIXING BLADE	LAME DE FIXAGE	BEFESTIGUNGSSCHIL D	LAMA FIJACIÓN
9	068863A3	LAMA DI FISSAGGIO	FIXING BLADE	LAME DE FIXAGE	BEFESTIGUNGSSCHIL D	LAMA FIJACIÓN
9	068863A5	LAMA DI FISSAGGIO	FIXING BLADE	LAME DE FIXAGE	BEFESTIGUNGSSCHIL D	LAMA FIJACIÓN
9	068863A6	LAMA DI FISSAGGIO	FIXING BLADE	LAME DE FIXAGE	BEFESTIGUNGSSCHIL D	LAMA FIJACIÓN
9	068863A7	LAMA DI FISSAGGIO	FIXING BLADE	LAME DE FIXAGE	BEFESTIGUNGSSCHIL D	LAMA FIJACIÓN





Main color codes:  J1 - JLG Cream,  J2 - JLG Orange,  C4 - Green



 BASE TORRETTA TURRET BASE BASE TOURELLEARBEITSTURM BASE TORRETTA GIRATORIA 

POS	Codice	 Descrizione	 Description	 Designation	 Benennung	 Descripció
9	068863A9	LAMA DI FISSAGGIO	FIXING BLADE	LAME DE FIXAGE	BEFESTIGUNGSSCHIL D	LAMA FIJACIÓN
9	068863AG	LAMA DI FISSAGGIO	FIXING BLADE	LAME DE FIXAGE	BEFESTIGUNGSSCHIL D	LAMA FIJACIÓN
9	068863B1	LAMA DI FISSAGGIO	FIXING BLADE	LAME DE FIXAGE	BEFESTIGUNGSSCHIL D	LAMA FIJACIÓN
9	068863B9	LAMA DI FISSAGGIO	FIXING BLADE	LAME DE FIXAGE	BEFESTIGUNGSSCHIL D	LAMA FIJACIÓN
9	068863BC	LAMA DI FISSAGGIO	FIXING BLADE	LAME DE FIXAGE	BEFESTIGUNGSSCHIL D	LAMA FIJACIÓN
9	068863BP	LAMA DI FISSAGGIO	FIXING BLADE	LAME DE FIXAGE	BEFESTIGUNGSSCHIL D	LAMA FIJACIÓN
9	068863C4	LAMA DI FISSAGGIO	FIXING BLADE	LAME DE FIXAGE	BEFESTIGUNGSSCHIL D	LAMA FIJACIÓN
9	068863D5	LAMA DI FISSAGGIO	FIXING BLADE	LAME DE FIXAGE	BEFESTIGUNGSSCHIL D	LAMA FIJACIÓN
9	068863D7	LAMA DI FISSAGGIO	FIXING BLADE	LAME DE FIXAGE	BEFESTIGUNGSSCHIL D	LAMA FIJACIÓN
9	068863DI	LAMA DI FISSAGGIO	FIXING BLADE	LAME DE FIXAGE	BEFESTIGUNGSSCHIL D	LAMA FIJACIÓN
9	068863DT	LAMA DI FISSAGGIO	FIXING BLADE	LAME DE FIXAGE	BEFESTIGUNGSSCHIL D	LAMA FIJACIÓN
9	068863EM	LAMA DI FISSAGGIO	FIXING BLADE	LAME DE FIXAGE	BEFESTIGUNGSSCHIL D	LAMA FIJACIÓN
9	068863EW	LAMA DI FISSAGGIO	FIXING BLADE	LAME DE FIXAGE	BEFESTIGUNGSSCHIL D	LAMA FIJACIÓN
9	068863GB	LAMA DI FISSAGGIO	FIXING BLADE	LAME DE FIXAGE	BEFESTIGUNGSSCHIL D	LAMA FIJACIÓN
9	068863H1	LAMA DI FISSAGGIO	FIXING BLADE	LAME DE FIXAGE	BEFESTIGUNGSSCHIL D	LAMA FIJACIÓN
9	068863H2	LAMA DI FISSAGGIO	FIXING BLADE	LAME DE FIXAGE	BEFESTIGUNGSSCHIL D	LAMA FIJACIÓN
9	068863J2	LAMA DI FISSAGGIO	FIXING BLADE	LAME DE FIXAGE	BEFESTIGUNGSSCHIL D	LAMA FIJACIÓN





Main color codes:  J1 - JLG Cream,  J2 - JLG Orange,  C4 - Green



 BASE TORRETTA TURRET BASE BASE TOURELLEARBEITSTURM BASE TORRETTA GIRATORIA 

POS	Codice	 Descrizione	 Description	 Designation	 Benennung	 Descripción
10	061187Y1	PIASTRA	PLATE	PLAQUE	PLATTE	PLACA
11	061185Y1	LAMIERA PIEGATA	FOLDED PLATE	TÔLE PLIÉE	BLECH GEBOGEN	CHAPA DOBLADA
12	371398A1	SUPPORTO MOTORE ELETTRICO	ELECTRIC MOTOR SUPPORT	SOUTIEN MOTEUR ELECTRIC	SUPPORT MOTOR ELECTRIC	APOYO MOTOR ELÉCTRICA
12	371398A2	SUPPORTO MOTORE ELETTRICO	ELECTRIC MOTOR SUPPORT	SOUTIEN MOTEUR ELECTRIC	SUPPORT MOTOR ELECTRIC	APOYO MOTOR ELÉCTRICA
12	371398A3	SUPPORTO MOTORE ELETTRICO	ELECTRIC MOTOR SUPPORT	SOUTIEN MOTEUR ELECTRIC	SUPPORT MOTOR ELECTRIC	APOYO MOTOR ELÉCTRICA
12	371398A5	SUPPORTO MOTORE ELETTRICO	ELECTRIC MOTOR SUPPORT	SOUTIEN MOTEUR ELECTRIC	SUPPORT MOTOR ELECTRIC	APOYO MOTOR ELÉCTRICA
12	371398A6	SUPPORTO	SUPPORT	SUPPORT	HALTERUNG	SOPORTE
12	371398A7	SUPPORTO MOTORE ELETTRICO	ELECTRIC MOTOR SUPPORT	SOUTIEN MOTEUR ELECTRIC	SUPPORT MOTOR ELECTRIC	APOYO MOTOR ELÉCTRICA
12	371398A9	SUPPORTO	SUPPORT	SUPPORT	HALTERUNG	SOPORTE
12	371398AG	SUPPORTO MOTORE ELETTRICO	ELECTRIC MOTOR SUPPORT	SOUTIEN MOTEUR ELECTRIC	SUPPORT MOTOR ELECTRIC	APOYO MOTOR ELÉCTRICA
12	371398B1	SUPPORTO MOTORE ELETTRICO	ELECTRIC MOTOR SUPPORT	SOUTIEN MOTEUR ELECTRIC	SUPPORT MOTOR ELECTRIC	APOYO MOTOR ELÉCTRICA
12	371398B9	SUPPORTO	SUPPORT	SUPPORT	HALTERUNG	SOPORTE
12	371398BC	SUPPORTO MOTORE ELETTRICO	ELECTRIC MOTOR SUPPORT	SOUTIEN MOTEUR ELECTRIC	SUPPORT MOTOR ELECTRIC	APOYO MOTOR ELÉCTRICA
12	371398BP	SUPPORTO MOTORE ELETTRICO	ELECTRIC MOTOR SUPPORT	SOUTIEN MOTEUR ELECTRIC	SUPPORT MOTOR ELECTRIC	APOYO MOTOR ELÉCTRICA
12	371398C4	SUPPORTO MOTORE ELETTRICO	ELECTRIC MOTOR SUPPORT	SOUTIEN MOTEUR ELECTRIC	SUPPORT MOTOR ELECTRIC	APOYO MOTOR ELÉCTRICA
12	371398D5	SUPPORTO MOTORE ELETTRICO	ELECTRIC MOTOR SUPPORT	SOUTIEN MOTEUR ELECTRIC	SUPPORT MOTOR ELECTRIC	APOYO MOTOR ELÉCTRICA
12	371398D7	SUPPORTO MOTORE ELETTRICO	ELECTRIC MOTOR SUPPORT	SOUTIEN MOTEUR ELECTRIC	SUPPORT MOTOR ELECTRIC	APOYO MOTOR ELÉCTRICA
12	371398DI	SUPPORTO MOTORE ELETTRICO	ELECTRIC MOTOR SUPPORT	SOUTIEN MOTEUR ELECTRIC	SUPPORT MOTOR ELECTRIC	APOYO MOTOR ELÉCTRICA
12	371398DT	SUPPORTO	SUPPORT	SUPPORT	HALTERUNG	SOPORTE
12	371398EM	SUPPORTO	SUPPORT	SUPPORT	HALTERUNG	SOPORTE
12	371398EW	SUPPORTO	SUPPORT	SUPPORT	HALTERUNG	SOPORTE

Main color codes:  J1 - JLG Cream,  J2 - JLG Orange,  C4 - Green

 BASE TORRETTA TURRET BASE BASE TOURELLEARBEITSTURM BASE TORRETTA GIRATORIA 



POS	Codice	 Descrizione	 Description	 Designation	 Benennung	 Descripció
12	371398GB	SUPPORTO MOTORE ELETTRICO	ELECTRIC MOTOR SUPPORT	SOUTIEN MOTEUR ELECTRIC	SUPPORT MOTOR ELECTRIC	APOYO MOTOR ELÉCTRICA
12	371398H1	SUPPORTO	SUPPORT	SUPPORT	HALTERUNG	SOPORTE
12	371398H2	SUPPORTO MOTORE ELETTRICO	ELECTRIC MOTOR SUPPORT	SOUTIEN MOTEUR ELECTRIC	SUPPORT MOTOR ELECTRIC	APOYO MOTOR ELÉCTRICA
12	371398J2	SUPPORTO MOTORE ELETTRICO SALDATO	WELDED SUPPORT ELECTRIC MOTOR	SUPPORT	HALTERUNG	SOPORTE
13	07131600	SPINA	PIN	CHEVILLE	STIF	CLAVIJA
14	171392A1	STABILIZZATORE COMPLETO	COMPLETE STABILIZER	STABILISATEUR COMPLET	STABILIZER KOMPLETT	ESTABILIZADOR COMPLETO
14	171392A2	STABILIZZATORE COMPLETO	COMPLETE STABILIZER	STABILISATEUR COMPLET	STABILIZER KOMPLETT	ESTABILIZADOR COMPLETO
14	171392A3	STABILIZZATORE COMPLETO	COMPLETE STABILIZER	STABILISATEUR COMPLET	STABILIZER KOMPLETT	ESTABILIZADOR COMPLETO
14	171392A5	STABILIZZATORE COMPLETO	COMPLETE STABILIZER	STABILISATEUR COMPLET	STABILIZER KOMPLETT	ESTABILIZADOR COMPLETO
14	171392A6	STABILIZZATORE COMPLETO	COMPLETE STABILIZER	STABILISATEUR COMPLET	STABILIZER KOMPLETT	ESTABILIZADOR COMPLETO
14	171392A7	STABILIZZATORE COMPLETO	COMPLETE STABILIZER	STABILISATEUR COMPLET	STABILIZER KOMPLETT	ESTABILIZADOR COMPLETO
14	171392A9	STABILIZZATORE COMPLETO	COMPLETE STABILIZER	STABILISATEUR COMPLET	STABILIZER KOMPLETT	ESTABILIZADOR COMPLETO
14	171392AG	STABILIZZATORE COMPLETO	COMPLETE STABILIZER	STABILISATEUR COMPLET	STABILIZER KOMPLETT	ESTABILIZADOR COMPLETO
14	171392B1	STABILIZZATORE COMPLETO	COMPLETE STABILIZER	STABILISATEUR COMPLET	STABILIZER KOMPLETT	ESTABILIZADOR COMPLETO
14	171392B9	STABILIZZATORE COMPLETO	COMPLETE STABILIZER	STABILISATEUR COMPLET	STABILIZER KOMPLETT	ESTABILIZADOR COMPLETO
14	171392BC	STABILIZZATORE COMPLETO	COMPLETE STABILIZER	STABILISATEUR COMPLET	STABILIZER KOMPLETT	ESTABILIZADOR COMPLETO
14	171392BP	STABILIZZATORE COMPLETO	COMPLETE STABILIZER	STABILISATEUR COMPLET	STABILIZER KOMPLETT	ESTABILIZADOR COMPLETO
14	171392C4	STABILIZZATORE COMPLETO	COMPLETE STABILIZER	STABILISATEUR COMPLET	STABILIZER KOMPLETT	ESTABILIZADOR COMPLETO

Main color codes:  J1 - JLG Cream,  J2 - JLG Orange,  C4 - Green





 BASE TORRETTA TURRET BASE BASE TOURELLEARBEITSTURM BASE TORRETTA GIRATORIA 

POS	Codice	 Descrizione	 Description	 Designation	 Benennung	 Descripción
14	171392D5	STABILIZZATORE COMPLETO	COMPLETE STABILIZER	STABILISATEUR COMPLET	STABILIZER KOMPLETT	ESTABILIZADOR COMPLETO
14	171392D7	STABILIZZATORE COMPLETO	COMPLETE STABILIZER	STABILISATEUR COMPLET	STABILIZER KOMPLETT	ESTABILIZADOR COMPLETO
14	171392DI	STABILIZZATORE COMPLETO	COMPLETE STABILIZER	STABILISATEUR COMPLET	STABILIZER KOMPLETT	ESTABILIZADOR COMPLETO
14	171392DT	STABILIZZATORE COMPLETO	COMPLETE STABILIZER	STABILISATEUR COMPLET	STABILIZER KOMPLETT	ESTABILIZADOR COMPLETO
14	171392EM	STABILIZZATORE COMPLETO	COMPLETE STABILIZER	STABILISATEUR COMPLET	STABILIZER KOMPLETT	ESTABILIZADOR COMPLETO
14	171392EW	STABILIZZATORE COMPLETO	COMPLETE STABILIZER	STABILISATEUR COMPLET	STABILIZER KOMPLETT	ESTABILIZADOR COMPLETO
14	171392GB	STABILIZZATORE COMPLETO	COMPLETE STABILIZER	STABILISATEUR COMPLET	STABILIZER KOMPLETT	ESTABILIZADOR COMPLETO
14	171392H1	STABILIZZATORE COMPLETO	COMPLETE STABILIZER	STABILISATEUR COMPLET	STABILIZER KOMPLETT	ESTABILIZADOR COMPLETO
14	171392H2	STABILIZZATORE COMPLETO	COMPLETE STABILIZER	STABILISATEUR COMPLET	STABILIZER KOMPLETT	ESTABILIZADOR COMPLETO
14	171392J2	STABILIZZATORE COMPLETO	COMPLETE STABILIZER	STABILISATEUR COMPLET	STABILIZER KOMPLETT	ESTABILIZADOR COMPLETO
15	06272800	BOCCOLA	BUSH	DOUILLE	BUCHSE	CASQUILLO
16	28185800	ANTIVIBRANTE	ANTI-VIBRATING	ANTI - VIBRANT	VIBRATIONSDÄMPFE R	ANTIVIBRANTE
17	06236400	SPINA	PIN	CHEVILLE	STIF	CLAVIJA
18	05446300	DISCO	DISK	DISQUE	SCHEIBE	DISCO
19	054464Y1	SEMIFLANGIA	HALF FLANGE	DEMI-BRIDE	HALB FLANSCH	SEMI BRIDA
20	068910Y1	STAFFA	BRACKET	ÉTRIER	HALTEBÜGEL	ESTRIBO
20	076966H3	CARTER PROTEZIONE CENTRALINO MK2 (DA C170000893)	CARTER PROTECTION SWITCHBOARD MK2 (FROM C170000893)	CARTER	KURBELGEHÄUSE	CÁRTER
21	359330H2	SUPPORTO	SUPPORT	SUPPORT	HALTERUNG	SOPORTE
21	376834H2	SUPPORTO	SUPPORT	SUPPORT	HALTERUNG	SOPORTE





Main color codes:  J1 - JLG Cream,  J2 - JLG Orange,  C4 - Green



 BASE TORRETTA TURRET BASE BASE TOURELLEARBEITSTURM BASE TORRETTA GIRATORIA 

POS	Codice	 Descrizione	 Description	 Designation	 Benennung	 Descripción
22	07894800	GOMMA ADESIVA DI PROTEZIONE L=190	RUBBER ADHESIVE PROTECTION L=190	GOMME ADHESIVE DE PROTECTION L=190	SCHUTZ-KLEBEGUMMI L=190	GOMA ADHESIVA DE PROTECCIÓN L=190
22	07894900	GOMMA ADESIVA DI PROTEZIONE L=70	RUBBER ADHESIVE PROTECTION L=70	GOMME ADHESIVE DE PROTECTION L=70	SCHUTZ-KLEBEGUMMI L=70	GOMA ADHESIVA DE PROTECCIÓN L=70
23	261308H2	MOTORE DI ROTAZIONE	ROTARY MOTOR	MOTEUR DE ROTATION	ROTATIONSMOTOR	MOTOR DE ROTACIÓN
24	059328H2	PROTEZIONE DESTRA	PROTECTION RIGHT	PROTECTION DROITE	SCHUTZ RECHT	PROTECCIÓN
24	059591H2	PROTEZIONE SINISTRA	PROTECTION LEFT	PROTECTION GAUCHE	SCHUTZ LINK	PROTECCIÓN
25	371407A1	SUPPORTO MOTORE BENZINA	GASOLINE ENGINE SUPPORT	ESSENCE SUPPORT MOTEUR	BENZINMOTOR SUPPORT	MOTOR DE GASOLINA DE APOYO
25	371407A2	SUPPORTO MOTORE BENZINA	GASOLINE ENGINE SUPPORT	ESSENCE SUPPORT MOTEUR	BENZINMOTOR SUPPORT	MOTOR DE GASOLINA DE APOYO
25	371407A7	SUPPORTO MOTORE BENZINA	GASOLINE ENGINE SUPPORT	ESSENCE SUPPORT MOTEUR	BENZINMOTOR SUPPORT	MOTOR DE GASOLINA DE APOYO
25	371407A9	SUPPORTO	SUPPORT	SUPPORT	HALTERUNG	SOPORTE
25	371407B1	SUPPORTO MOTORE BENZINA	GASOLINE ENGINE SUPPORT	ESSENCE SUPPORT MOTEUR	BENZINMOTOR SUPPORT	MOTOR DE GASOLINA DE APOYO
25	371407B9	SUPPORTO	SUPPORT	SUPPORT	HALTERUNG	SOPORTE
25	371407BP	SUPPORTO	SUPPORT	SUPPORT	HALTERUNG	SOPORTE
25	371407D7	SUPPORTO MOTORE BENZINA	GASOLINE ENGINE SUPPORT	ESSENCE SUPPORT MOTEUR	BENZINMOTOR SUPPORT	MOTOR DE GASOLINA DE APOYO
25	371407DT	SUPPORTO	SUPPORT	SUPPORT	HALTERUNG	SOPORTE
25	371407H1	SUPPORTO	SUPPORT	SUPPORT	HALTERUNG	SOPORTE
25	371407J2	SUPPORTO	SUPPORT	SUPPORT	HALTERUNG	SOPORTE
25	371409A2	SUPPORTO MOTORE DIESEL	DIESEL ENGINE SUPPORT	SUPPORT	HALTERUNG	SOPORTE
25	371409A3	SUPPORTO MOTORE DIESEL	DIESEL ENGINE SUPPORT	SUPPORT	HALTERUNG	SOPORTE
25	371409A5	SUPPORTO	SUPPORT	SUPPORT	HALTERUNG	SOPORTE
25	371409A6	SUPPORTO MOTORE DIESEL	DIESEL ENGINE SUPPORT	SUPPORT	HALTERUNG	SOPORTE
25	371409A7	SUPPORTO	SUPPORT	SUPPORT	HALTERUNG	SOPORTE





Main color codes:  J1 - JLG Cream,  J2 - JLG Orange,  C4 - Green



 BASE TORRETTA TURRET BASE BASE TOURELLEARBEITSTURM BASE TORRETTA GIRATORIA 

POS	Codice	 Descrizione	 Description	 Designation	 Benennung	 Descripción
25	371409A9	SUPPORTO MOTORE DIESEL	DIESEL ENGINE SUPPORT	SUPPORT	HALTERUNG	SOPORTE
25	371409AG	SUPPORTO MOTORE DIESEL	DIESEL ENGINE SUPPORT	SUPPORT	HALTERUNG	SOPORTE
25	371409BP	SUPPORTO MOTORE DIESEL	DIESEL ENGINE SUPPORT	SUPPORT	HALTERUNG	SOPORTE
25	371409D5	SUPPORTO MOTORE DIESEL	DIESEL ENGINE SUPPORT	SUPPORT	HALTERUNG	SOPORTE
25	371409DI	SUPPORTO	SUPPORT	SUPPORT	HALTERUNG	SOPORTE
25	371409DT	SUPPORTO MOTORE DIESEL	DIESEL ENGINE SUPPORT	SUPPORT	HALTERUNG	SOPORTE
25	371409EM	SUPPORTO MOTORE DIESEL	DIESEL ENGINE SUPPORT	SUPPORT	HALTERUNG	SOPORTE
25	371409EW	SUPPORTO MOTORE DIESEL	DIESEL ENGINE SUPPORT	SUPPORT	HALTERUNG	SOPORTE
25	371409GB	SUPPORTO	SUPPORT	SUPPORT	HALTERUNG	SOPORTE
25	371409H1	SUPPORTO MOTORE DIESEL	DIESEL ENGINE SUPPORT	SUPPORT	HALTERUNG	SOPORTE
25	371409H2	SUPPORTO MOTORE DIESEL	DIESEL ENGINE SUPPORT	SUPPORT	HALTERUNG	SOPORTE
25	371409J2	SUPPORTO MOTORE DIESEL	DIESEL ENGINE SUPPORT	SUPPORT	HALTERUNG	SOPORTE
26	055629H3	STAFFA	BRACKET	ÉTRIER	HALTEBÜGEL	ESTRIBO
27	07141100	COPERCHIO FILTRO ARIA MOTORE HONDA	AIR FILTER COVER HONDA MOTOR	COUVERCLE	DECKEL	TAPA
28	171449A1	ASSIEME PROTEZIONE MOTORE HONDA COMPLETA	HONDA MOTOR PROTECTION	PROTECTION	SCHUTZ	PROTECCIÓN
28	171449A2	PROTEZIONE	PROTECTION	PROTECTION	SCHUTZ	PROTECCIÓN





Main color codes:  J1 - JLG Cream,  J2 - JLG Orange,  C4 - Green



 BASE TORRETTA TURRET BASE BASE TOURELLEARBEITSTURM BASE TORRETTA GIRATORIA 

POS	Codice	 Descrizione	 Description	 Designation	 Benennung	 Descripción
28	171449A7	ASSIEME PROTEZIONE MOTORE HONDA COMPLETA	HONDA MOTOR PROTECTION	PROTECTION	SCHUTZ	PROTECCIÓN
28	171449A9	ASSIEME PROTEZIONE MOTORE HONDA COMPLETA	HONDA MOTOR PROTECTION	PROTECTION	SCHUTZ	PROTECCIÓN
28	171449B1	ASSIEME PROTEZIONE MOTORE HONDA COMPLETA	HONDA MOTOR PROTECTION	PROTECTION	SCHUTZ	PROTECCIÓN
28	171449B9	ASSIEME PROTEZIONE MOTORE HONDA COMPLETA	HONDA MOTOR PROTECTION	PROTECTION	SCHUTZ	PROTECCIÓN
28	171449BP	PROTEZIONE	PROTECTION	PROTECTION	SCHUTZ	PROTECCIÓN
28	171449D7	ASSIEME PROTEZIONE MOTORE HONDA COMPLETA	HONDA MOTOR PROTECTION	PROTECTION	SCHUTZ	PROTECCIÓN
28	171449DT	ASSIEME PROTEZIONE MOTORE HONDA COMPLETA	HONDA MOTOR PROTECTION	PROTECTION	SCHUTZ	PROTECCIÓN
28	171449H2	PROTEZIONE	PROTECTION	PROTECTION	SCHUTZ	PROTECCIÓN
28	171449J2	PROTEZIONE	PROTECTION	PROTECTION	SCHUTZ	PROTECCIÓN
28	371453A2	PROTEZIONE MOTORE DIESEL	PROTECTION DIESEL ENGINE	PROTECTION	SCHUTZ	PROTECCIÓN
28	371453A3	PROTEZIONE MOTORE DIESEL	PROTECTION DIESEL ENGINE	PROTECTION	SCHUTZ	PROTECCIÓN
28	371453A5	PROTEZIONE MOTORE DIESEL	PROTECTION DIESEL ENGINE	PROTECTION	SCHUTZ	PROTECCIÓN





Main color codes:  J1 - JLG Cream,  J2 - JLG Orange,  C4 - Green



 BASE TORRETTA TURRET BASE BASE TOURELLEARBEITSTURM BASE TORRETTA GIRATORIA 

POS	Codice	 Descrizione	 Description	 Designation	 Benennung	 Descripción
28	371453A6	PROTEZIONE MOTORE DIESEL	PROTECTION DIESEL ENGINE	PROTECTION	SCHUTZ	PROTECCIÓN
28	371453A7	PROTEZIONE MOTORE DIESEL	PROTECTION DIESEL ENGINE	PROTECTION	SCHUTZ	PROTECCIÓN
28	371453A9	PROTEZIONE MOTORE DIESEL	PROTECTION DIESEL ENGINE	PROTECTION	SCHUTZ	PROTECCIÓN
28	371453AG	PROTEZIONE MOTORE DIESEL	PROTECTION DIESEL ENGINE	PROTECTION	SCHUTZ	PROTECCIÓN
28	371453BP	PROTEZIONE MOTORE DIESEL	PROTECTION DIESEL ENGINE	PROTECTION	SCHUTZ	PROTECCIÓN
28	371453D5	PROTEZIONE MOTORE DIESEL	PROTECTION DIESEL ENGINE	PROTECTION	SCHUTZ	PROTECCIÓN
28	371453DI	PROTEZIONE MOTORE DIESEL	PROTECTION DIESEL ENGINE	PROTECTION	SCHUTZ	PROTECCIÓN
28	371453DT	PROTEZIONE MOTORE DIESEL	PROTECTION DIESEL ENGINE	PROTECTION	SCHUTZ	PROTECCIÓN
28	371453EM	PROTEZIONE MOTORE DIESEL	PROTECTION DIESEL ENGINE	PROTECTION	SCHUTZ	PROTECCIÓN
28	371453EW	PROTEZIONE MOTORE DIESEL	PROTECTION DIESEL ENGINE	PROTECTION	SCHUTZ	PROTECCIÓN
28	371453GB	PROTEZIONE MOTORE DIESEL	PROTECTION DIESEL ENGINE	PROTECTION	SCHUTZ	PROTECCIÓN
28	371453H1	PROTEZIONE MOTORE DIESEL	PROTECTION DIESEL ENGINE	PROTECTION	SCHUTZ	PROTECCIÓN
28	371453H2	PROTEZIONE MOTORE DIESEL	PROTECTION DIESEL ENGINE	PROTECTION	SCHUTZ	PROTECCIÓN
28	371453J2	PROTEZIONE MOTORE DIESEL	PROTECTION DIESEL ENGINE	PROTECTION	SCHUTZ	PROTECCIÓN
29	068911Y1	FERMO	RETAINER	ARRÊT	HALTERUNG	BLOQUE
30	068887Y1	RISCONTRO	FASTENER LOCATOR	PLAQUE POUR AGRAFAGE	ANSCHLAG	GANCHO
30	077710Y1	RISCONTRO	FASTENER LOCATOR	PLAQUE POUR AGRAFAGE	ANSCHLAG	GANCHO
31	070025H2	CARTER	SUMP	CARTER	KURBELGEHÄUSE	CÁRTER

Main color codes:  J1 - JLG Cream,  J2 - JLG Orange,  C4 - Green



 BASE TORRETTA TURRET BASE BASE TOURELLEARBEITSTURM BASE TORRETTA GIRATORIA 

POS	Codice	 Descrizione	 Description	 Designation	 Benennung	 Descripción
32	069587H3	PIEGATO FISSAGGIO SPINA ELETTRICA 16A	FIXING FOLDED ELECTRIC PLUG 16A	TÔLE PLIÉE	BLECH GEBOGEN	CHAPA DOBLADA
33	072282A1	COPERCHIO	COVER	COUVERCLE	DECKEL	TAPA
33	072282A2	COPERCHIO	COVER	COUVERCLE	DECKEL	TAPA
33	072282A3	COPERCHIO	COVER	COUVERCLE	DECKEL	TAPA
33	072282A5	COPERCHIO	COVER	COUVERCLE	DECKEL	TAPA
33	072282A6	COPERCHIO	COVER	COUVERCLE	DECKEL	TAPA
33	072282A7	COPERCHIO	COVER	COUVERCLE	DECKEL	TAPA
33	072282A9	COPERCHIO	COVER	COUVERCLE	DECKEL	TAPA
33	072282AG	COPERCHIO	COVER	COUVERCLE	DECKEL	TAPA
33	072282B1	COPERCHIO	COVER	COUVERCLE	DECKEL	TAPA
33	072282B9	COPERCHIO	COVER	COUVERCLE	DECKEL	TAPA
33	072282BC	COPERCHIO	COVER	COUVERCLE	DECKEL	TAPA
33	072282BP	COPERCHIO	COVER	COUVERCLE	DECKEL	TAPA
33	072282C4	COPERCHIO	COVER	COUVERCLE	DECKEL	TAPA
33	072282D5	COPERCHIO	COVER	COUVERCLE	DECKEL	TAPA
33	072282D7	COPERCHIO	COVER	COUVERCLE	DECKEL	TAPA
33	072282DI	COPERCHIO	COVER	COUVERCLE	DECKEL	TAPA
33	072282DT	COPERCHIO	COVER	COUVERCLE	DECKEL	TAPA
33	072282EM	COPERCHIO	COVER	COUVERCLE	DECKEL	TAPA
33	072282EW	COPERCHIO	COVER	COUVERCLE	DECKEL	TAPA
33	072282GB	COPERCHIO	COVER	COUVERCLE	DECKEL	TAPA
33	072282H1	COPERCHIO	COVER	COUVERCLE	DECKEL	TAPA
33	072282H2	COPERCHIO	COVER	COUVERCLE	DECKEL	TAPA
33	072282J2	COPERCHIO	COVER	COUVERCLE	DECKEL	TAPA
34	07178700	CERNIERA CON CONTROLLO DELLA POSIZIONE	HINGES WITH POSITION CONTROL	CHARNIÈRE	SCHARNIER	BISAGRA
34	07189900	CERNIERA A OSCILLAZIONE LIBERA	HINGE SWING FREE	CHARNIÈRE	SCHARNIER	BISAGRA
35	071918H3	LAMIERA PIEGATA	FOLDED PLATE	TÔLE PLIÉE	BLECH GEBOGEN	CHAPA DOBLADA
36	36851000	CASSONE	DUMPER BED	CAISSON	DUMPERMULDE	CAJON

Main color codes:  J1 - JLG Cream,  J2 - JLG Orange,  C4 - Green



 BASE TORRETTA TURRET BASE BASE TOURELLEARBEITSTURM BASE TORRETTA GIRATORIA 



POS	Codice	 Descrizione	 Description	 Designation	 Benennung	 Descripción
37	06853100	COPERCHIO	COVER	COUVERCLE	DECKEL	TAPA
38	06779900	TAPPO VENTOLA ANTERIORE	CAP FRONT FAN	BOUCHON	VERSCHLUSS	TAPÓN
39	06780800	TAPPO VENTOLA POSTERIORE	CAP REAR FAN	BOUCHON	VERSCHLUSS	TAPÓN
40	059679D2	INDICE ALLINEAMENTO FISSO	FIXED ALIGNMENT INDICATOR	INDICATEUR D'ALIGNEMENT FIXE	FIXE AUSRICHTUNGSANZEIGE	INDICADOR ALINEACIÓN FIJO
41	04834500	CLAXON 12V	HORN	KLAXON	HORN	BOCINA
42	06550100	VITE M16X20 TESTA RIBASSATA	REDUCED HEAD SCREW M16X20	BAISSE VIS À TÊTE M16X20	GESENKTEN KOPF SCREW M16X20	BAJADO TORNILLO CABEZA M16X20

Main color codes:  J1 - JLG Cream,  J2 - JLG Orange,  C4 - Green









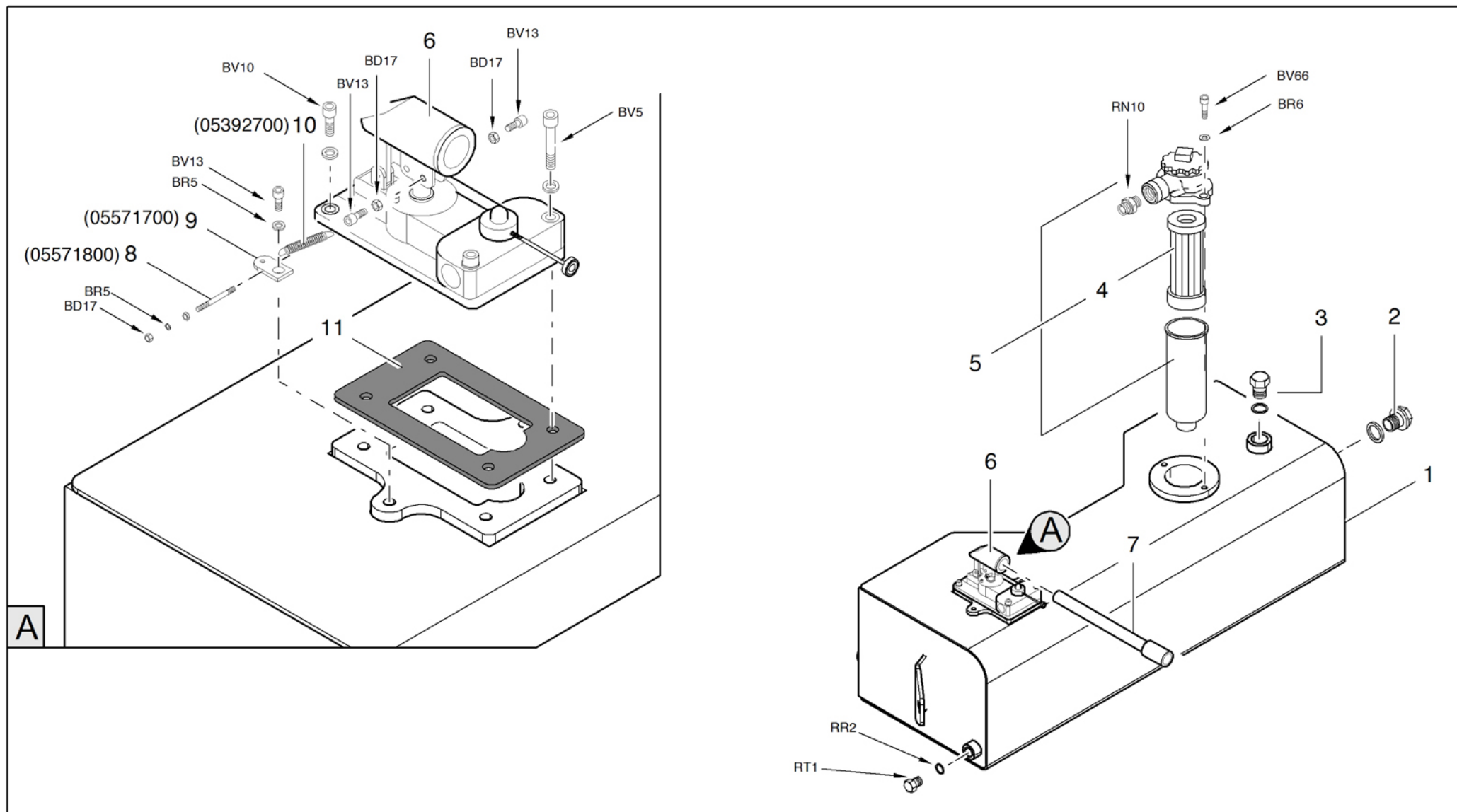



 SERBATOIO OLIO  
 OIL TANK  
 RÉSERVOIR D'HUILE





ÖLTANK   
 DEPÓSITO DE ACEITE 







Main color codes:  J1 - JLG Cream,  J2 - JLG Orange,  C4 - Green





 SERBATOIO OLIO  
 OIL TANK  
 RÉSERVOIR D'HUILE

ÖLTANK   
 DEPÓSITO DE ACEITE 

POS	Codice	 Descrizione	 Description	 Designation	 Benennung	 Descripció
1	173164A1	SERBATOIO OLIO COMPLETO	OIL TANK	RÉSERVOIR D'HUILE COMPLET	OIL TANK FULL	ACEITE DE TANQUE LLENO
1	173164A2	SERBATOIO OLIO COMPLETO	OIL TANK	RÉSERVOIR D'HUILE COMPLET	OIL TANK FULL	ACEITE DE TANQUE LLENO
1	173164A3	SERBATOIO OLIO COMPLETO	OIL TANK	RÉSERVOIR D'HUILE COMPLET	OIL TANK FULL	ACEITE DE TANQUE LLENO
1	173164A5	SERBATOIO OLIO COMPLETO	OIL TANK	RÉSERVOIR D'HUILE COMPLET	OIL TANK FULL	ACEITE DE TANQUE LLENO
1	173164A6	SERBATOIO OLIO	OIL TANK	RÉSERVOIR D'HUILE	ÖLTANK	DEPÓSITO DE ACEITE
1	173164A7	SERBATOIO OLIO COMPLETO	OIL TANK	RÉSERVOIR D'HUILE COMPLET	OIL TANK FULL	ACEITE DE TANQUE LLENO
1	173164A9	SERBATOIO OLIO	OIL TANK	RÉSERVOIR D'HUILE	ÖLTANK	DEPÓSITO DE ACEITE
1	173164AG	SERBATOIO OLIO COMPLETO	OIL TANK	RÉSERVOIR D'HUILE COMPLET	OIL TANK FULL	ACEITE DE TANQUE LLENO
1	173164B1	SERBATOIO OLIO COMPLETO	OIL TANK	RÉSERVOIR D'HUILE COMPLET	OIL TANK FULL	ACEITE DE TANQUE LLENO
1	173164B9	SERBATOIO OLIO	OIL TANK	RÉSERVOIR D'HUILE	ÖLTANK	DEPÓSITO DE ACEITE
1	173164BC	SERBATOIO OLIO COMPLETO	OIL TANK	RÉSERVOIR D'HUILE COMPLET	OIL TANK FULL	ACEITE DE TANQUE LLENO
1	173164BP	SERBATOIO OLIO COMPLETO	OIL TANK	RÉSERVOIR D'HUILE COMPLET	OIL TANK FULL	ACEITE DE TANQUE LLENO
1	173164C4	SERBATOIO OLIO COMPLETO	OIL TANK	RÉSERVOIR D'HUILE COMPLET	OIL TANK FULL	ACEITE DE TANQUE LLENO
1	173164D5	SERBATOIO OLIO COMPLETO	OIL TANK	RÉSERVOIR D'HUILE COMPLET	OIL TANK FULL	ACEITE DE TANQUE LLENO
1	173164D7	SERBATOIO OLIO COMPLETO	OIL TANK	RÉSERVOIR D'HUILE COMPLET	OIL TANK FULL	ACEITE DE TANQUE LLENO
1	173164DI	SERBATOIO OLIO COMPLETO	OIL TANK	RÉSERVOIR D'HUILE COMPLET	OIL TANK FULL	ACEITE DE TANQUE LLENO
1	173164DT	SERBATOIO OLIO	OIL TANK	RÉSERVOIR D'HUILE	ÖLTANK	DEPÓSITO DE ACEITE
1	173164EM	SERBATOIO OLIO	OIL TANK	RÉSERVOIR D'HUILE	ÖLTANK	DEPÓSITO DE ACEITE
1	173164EW	SERBATOIO OLIO	OIL TANK	RÉSERVOIR D'HUILE	ÖLTANK	DEPÓSITO DE ACEITE
1	173164GB	SERBATOIO OLIO COMPLETO	OIL TANK	RÉSERVOIR D'HUILE COMPLET	OIL TANK FULL	ACEITE DE TANQUE LLENO

Main color codes:  J1 - JLG Cream,  J2 - JLG Orange,  C4 - Green



 SERBATOIO OLIO OIL TANK RÉSERVOIR D'HUILEÖLTANK DEPÓSITO DE ACEITE 

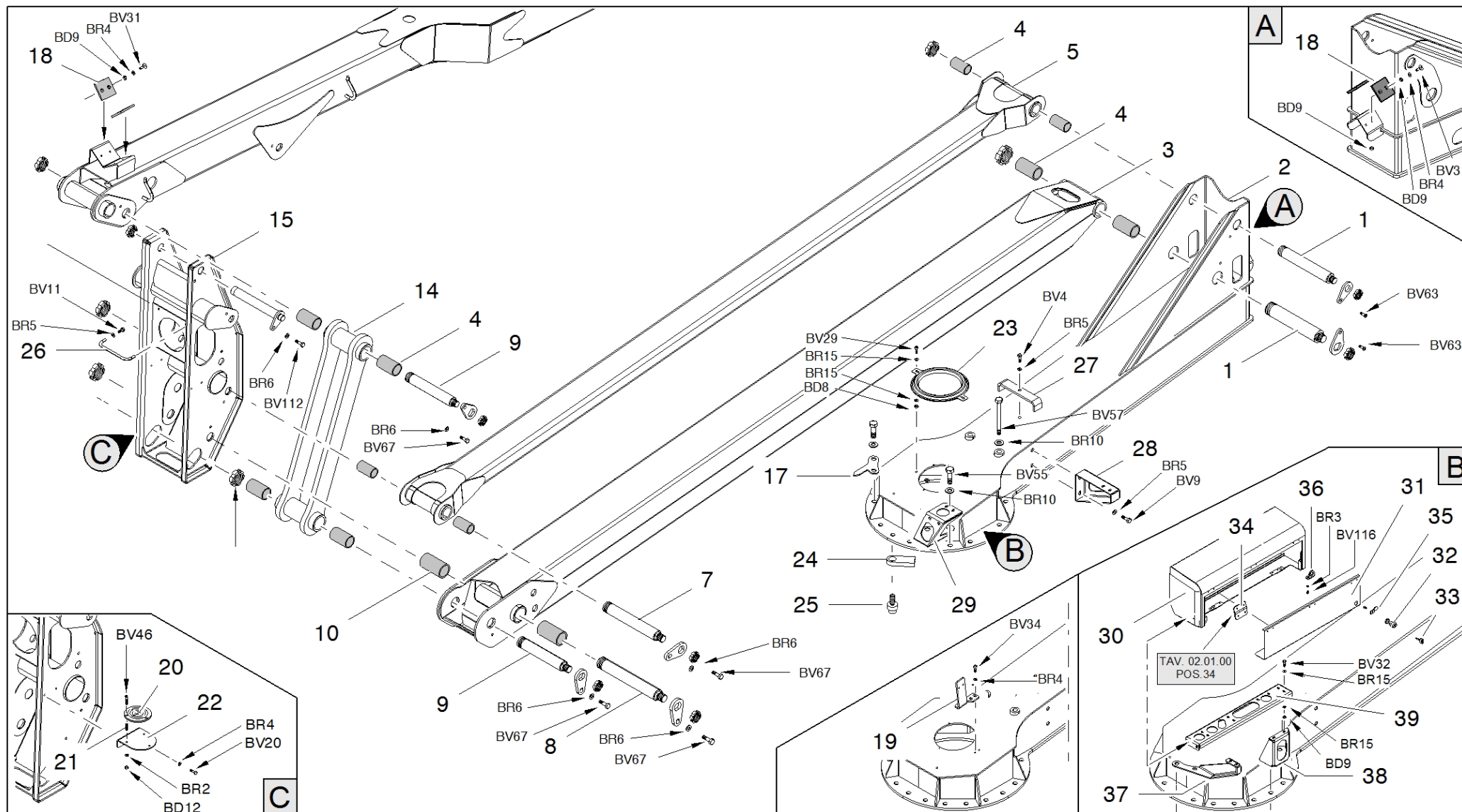

POS	Codice	 Descrizione	 Description	 Designation	 Benennung	 Descripción
1	173164H1	SERBATOIO OLIO	OIL TANK	RÉSERVOIR D'HUILE	ÖLTANK	DEPÓSITO DE ACEITE
1	173164H2	SERBATOIO OLIO COMPLETO	OIL TANK	RÉSERVOIR D'HUILE COMPLET	OIL TANK FULL	ACEITE DE TANQUE LLENO
1	173164J2	SERBATOIO OLIO	OIL TANK	RÉSERVOIR D'HUILE	ÖLTANK	DEPÓSITO DE ACEITE
2	05061800	LIVELLO OLIO	OIL LEVEL	NIVEAU HUILE	ÖLSTAND	NIVEL ACEITE
3	05611800	TAPPO OLIO	OIL PLUG	BOUCHON D'HUILE	ÖLDECKEL	TAPÓN ACEITE
4	05120200	CARTUCCIA FILTRO OLIO IDRAULICO	HYDRAULIC FILTER	CARTOUCHE FILTRE À HUILE	ÖLFILTEREINSATZ	CARTUCHO FILTRO ACEITE
5	15120100	FILTRO OLIO IDRAULICO COMPLETO	COMPLETE HYDRAULIC OIL FILTER	FILTRE À HUILE	HYDARULIKÖLFILTE R	FILTRO ACEITE HIDRÁULICO
6	27316300	POMPA A MANO	HAND PUMP	POMPE MANUELLE	HANDPUMPE	BOMBA DE MANO
7	2550890002	LEVA DI AZIONAMENTO PER POMPA	START LEVER FOR PUMP	LEVIER	HEBEL	PALANCA
11	2550890001	GUARNIZIONE DI BASE PER POMPA A MANO	BASIC GASKET FOR HAND PUMP	JOINT	DICHTUNG FÜR PUMPE	JUNTA





 PRIMO BRACCIO FIRST ARM PREMIER BRASERSTER AUSLEGERARM PRIMO BRAZO 





POS	Codice	 Descrizione	 Description	 Designation	 Benennung	 Descripción
1	07103700	SPINA	PIN	CHEVILLE	STIF	CLAVIJA
2	371060A1	ASSIEME SUPPORTO BRACCI	ASSEMBLY SUPPORT ARMS	ENSEMBLE BRAS DE SUPPORT	TOGETHER TRAGARME	JUNTOS APOYO DE LOS BRAZOS
2	371060A3	ASSIEME SUPPORTO BRACCI	ASSEMBLY SUPPORT ARMS	ENSEMBLE BRAS DE SUPPORT	TOGETHER TRAGARME	JUNTOS APOYO DE LOS BRAZOS
2	371060A5	ASSIEME SUPPORTO BRACCI	ASSEMBLY SUPPORT ARMS	ENSEMBLE BRAS DE SUPPORT	TOGETHER TRAGARME	JUNTOS APOYO DE LOS BRAZOS
2	371060A7	ASSIEME SUPPORTO BRACCI	ASSEMBLY SUPPORT ARMS	ENSEMBLE BRAS DE SUPPORT	TOGETHER TRAGARME	JUNTOS APOYO DE LOS BRAZOS
2	371060A9	ASSIEME SUPPORTO BRACCI	ASSEMBLY SUPPORT ARMS	ENSEMBLE BRAS DE SUPPORT	TOGETHER TRAGARME	JUNTOS APOYO DE LOS BRAZOS
2	371060AG	ASSIEME SUPPORTO BRACCI	ASSEMBLY SUPPORT ARMS	ENSEMBLE BRAS DE SUPPORT	TOGETHER TRAGARME	JUNTOS APOYO DE LOS BRAZOS
2	371060B1	ASSIEME SUPPORTO BRACCI	ASSEMBLY SUPPORT ARMS	ENSEMBLE BRAS DE SUPPORT	TOGETHER TRAGARME	JUNTOS APOYO DE LOS BRAZOS
2	371060B9	ASSIEME SUPPORTO BRACCI	ASSEMBLY SUPPORT ARMS	ENSEMBLE BRAS DE SUPPORT	TOGETHER TRAGARME	JUNTOS APOYO DE LOS BRAZOS
2	371060BC	ASSIEME SUPPORTO BRACCI	ASSEMBLY SUPPORT ARMS	ENSEMBLE BRAS DE SUPPORT	TOGETHER TRAGARME	JUNTOS APOYO DE LOS BRAZOS
2	371060BP	ASSIEME SUPPORTO BRACCI	ASSEMBLY SUPPORT ARMS	ENSEMBLE BRAS DE SUPPORT	TOGETHER TRAGARME	JUNTOS APOYO DE LOS BRAZOS
2	371060C4	ASSIEME SUPPORTO BRACCI	ASSEMBLY SUPPORT ARMS	ENSEMBLE BRAS DE SUPPORT	TOGETHER TRAGARME	JUNTOS APOYO DE LOS BRAZOS
2	371060D1	ASSIEME SUPPORTO BRACCI	ASSEMBLY SUPPORT ARMS	ENSEMBLE BRAS DE SUPPORT	TOGETHER TRAGARME	JUNTOS APOYO DE LOS BRAZOS
2	371060D5	ASSIEME SUPPORTO BRACCI	ASSEMBLY SUPPORT ARMS	ENSEMBLE BRAS DE SUPPORT	TOGETHER TRAGARME	JUNTOS APOYO DE LOS BRAZOS
2	371060DI	ASSIEME SUPPORTO BRACCI	ASSEMBLY SUPPORT ARMS	ENSEMBLE BRAS DE SUPPORT	TOGETHER TRAGARME	JUNTOS APOYO DE LOS BRAZOS
2	371060DT	ASSIEME SUPPORTO BRACCI	ASSEMBLY SUPPORT ARMS	ENSEMBLE BRAS DE SUPPORT	TOGETHER TRAGARME	JUNTOS APOYO DE LOS BRAZOS
2	371060FC	ASSIEME SUPPORTO BRACCI	ASSEMBLY SUPPORT ARMS	ENSEMBLE BRAS DE SUPPORT	TOGETHER TRAGARME	JUNTOS APOYO DE LOS BRAZOS



Main color codes:  J1 - JLG Cream,  J2 - JLG Orange,  C4 - Green

 PRIMO BRACCIO

 FIRST ARM

 PREMIER BRAS
ERSTER AUSLEGERARM PRIMO BRAZO 





POS	Codice	 Descrizione	 Description	 Designation	 Benennung	 Descripción
2	371060FX	ASSIEME SUPPORTO BRACCI	ASSEMBLY SUPPORT ARMS	ENSEMBLE BRAS DE SUPPORT	TOGETHER TRAGARME	JUNTOS APOYO DE LOS BRAZOS
2	371060GB	ASSIEME SUPPORTO BRACCI	ASSEMBLY SUPPORT ARMS	ENSEMBLE BRAS DE SUPPORT	TOGETHER TRAGARME	JUNTOS APOYO DE LOS BRAZOS
2	371060H1	ASSIEME SUPPORTO BRACCI	ASSEMBLY SUPPORT ARMS	ENSEMBLE BRAS DE SUPPORT	TOGETHER TRAGARME	JUNTOS APOYO DE LOS BRAZOS
2	371060H2	ASSIEME SUPPORTO BRACCI	ASSEMBLY SUPPORT ARMS	ENSEMBLE BRAS DE SUPPORT	TOGETHER TRAGARME	JUNTOS APOYO DE LOS BRAZOS
2	371060J1	ASSIEME SUPPORTO BRACCI	ASSEMBLY SUPPORT ARMS	ENSEMBLE BRAS DE SUPPORT	TOGETHER TRAGARME	JUNTOS APOYO DE LOS BRAZOS
3	171295A1	PRIMO BRACCIO	FIRST ARM	PREMIER BRAS	ERSTER AUSLEGERARM	PRIMO BRAZO
3	171295A3	PRIMO BRACCIO	FIRST ARM	PREMIER BRAS	ERSTER AUSLEGERARM	PRIMO BRAZO
3	171295A5	PRIMO BRACCIO	FIRST ARM	PREMIER BRAS	ERSTER AUSLEGERARM	PRIMO BRAZO
3	171295A7	PRIMO BRACCIO	FIRST ARM	PREMIER BRAS	ERSTER AUSLEGERARM	PRIMO BRAZO
3	171295A9	PRIMO BRACCIO	FIRST ARM	PREMIER BRAS	ERSTER AUSLEGERARM	PRIMO BRAZO
3	171295AG	PRIMO BRACCIO	FIRST ARM	PREMIER BRAS	ERSTER AUSLEGERARM	PRIMO BRAZO
3	171295B1	PRIMO BRACCIO	FIRST ARM	PREMIER BRAS	ERSTER AUSLEGERARM	PRIMO BRAZO
3	171295B9	PRIMO BRACCIO	FIRST ARM	PREMIER BRAS	ERSTER AUSLEGERARM	PRIMO BRAZO
3	171295BC	PRIMO BRACCIO	FIRST ARM	PREMIER BRAS	ERSTER AUSLEGERARM	PRIMO BRAZO
3	171295BP	PRIMO BRACCIO	FIRST ARM	PREMIER BRAS	ERSTER AUSLEGERARM	PRIMO BRAZO
3	171295C4	PRIMO BRACCIO	FIRST ARM	PREMIER BRAS	ERSTER AUSLEGERARM	PRIMO BRAZO
3	171295D1	PRIMO BRACCIO	FIRST ARM	PREMIER BRAS	ERSTER AUSLEGERARM	PRIMO BRAZO



Main color codes:  J1 - JLG Cream,  J2 - JLG Orange,  C4 - Green

 PRIMO BRACCIO

 FIRST ARM





 PREMIER BRAS
ERSTER AUSLEGERARM PRIMO BRAZO 



POS	Codice	 Descrizione	 Description	 Designation	 Benennung	 Descripción
3	171295D5	PRIMO BRACCIO	FIRST ARM	PREMIER BRAS	ERSTER AUSLEGERARM	PRIMO BRAZO
3	171295DI	PRIMO BRACCIO	FIRST ARM	PREMIER BRAS	ERSTER AUSLEGERARM	PRIMO BRAZO
3	171295DT	PRIMO BRACCIO	FIRST ARM	PREMIER BRAS	ERSTER AUSLEGERARM	PRIMO BRAZO
3	171295FC	PRIMO BRACCIO	FIRST ARM	PREMIER BRAS	ERSTER AUSLEGERARM	PRIMO BRAZO
3	171295FX	PRIMO BRACCIO	FIRST ARM	PREMIER BRAS	ERSTER AUSLEGERARM	PRIMO BRAZO
3	171295GB	PRIMO BRACCIO	FIRST ARM	PREMIER BRAS	ERSTER AUSLEGERARM	PRIMO BRAZO
3	171295H1	PRIMO BRACCIO	FIRST ARM	PREMIER BRAS	ERSTER AUSLEGERARM	PRIMO BRAZO
3	171295H2	PRIMO BRACCIO	FIRST ARM	PREMIER BRAS	ERSTER AUSLEGERARM	PRIMO BRAZO
3	171295J1	PRIMO BRACCIO	FIRST ARM	PREMIER BRAS	ERSTER AUSLEGERARM	PRIMO BRAZO
5	171278A1	BIELLA	CONNECTING ROD	BIELLE	ZEITSTEUERUNGSVE RBINDUNG	BIELA
5	171278A3	BIELLA	CONNECTING ROD	BIELLE	ZEITSTEUERUNGSVE RBINDUNG	BIELA
5	171278A5	BIELLA	CONNECTING ROD	BIELLE	ZEITSTEUERUNGSVE RBINDUNG	BIELA
5	171278A7	BIELLA	CONNECTING ROD	BIELLE	ZEITSTEUERUNGSVE RBINDUNG	BIELA
5	171278A9	BIELLA	CONNECTING ROD	BIELLE	ZEITSTEUERUNGSVE RBINDUNG	BIELA
5	171278AG	BIELLA	CONNECTING ROD	BIELLE	ZEITSTEUERUNGSVE RBINDUNG	BIELA
5	171278B1	BIELLA	CONNECTING ROD	BIELLE	ZEITSTEUERUNGSVE RBINDUNG	BIELA
5	171278B9	BIELLA	CONNECTING ROD	BIELLE	ZEITSTEUERUNGSVE RBINDUNG	BIELA

Main color codes:  J1 - JLG Cream,  J2 - JLG Orange,  C4 - Green



 PRIMO BRACCIO FIRST ARM PREMIER BRASERSTER AUSLEGERARM PRIMO BRAZO 





POS	Codice	 Descrizione	 Description	 Designation	 Benennung	 Descripción
5	171278BC	BIELLA	CONNECTING ROD	BIELLE	ZEITSTEUERUNGSVE RBINDUNG	BIELA
5	171278BP	BIELLA	CONNECTING ROD	BIELLE	ZEITSTEUERUNGSVE RBINDUNG	BIELA
5	171278C4	BIELLA	CONNECTING ROD	BIELLE	ZEITSTEUERUNGSVE RBINDUNG	BIELA
5	171278D1	BIELLA	CONNECTING ROD	BIELLE	ZEITSTEUERUNGSVE RBINDUNG	BIELA
5	171278D5	BIELLA	CONNECTING ROD	BIELLE	ZEITSTEUERUNGSVE RBINDUNG	BIELA
5	171278DI	BIELLA	CONNECTING ROD	BIELLE	ZEITSTEUERUNGSVE RBINDUNG	BIELA
5	171278DT	BIELLA	CONNECTING ROD	BIELLE	ZEITSTEUERUNGSVE RBINDUNG	BIELA
5	171278FC	BIELLA	CONNECTING ROD	BIELLE	ZEITSTEUERUNGSVE RBINDUNG	BIELA
5	171278FX	BIELLA	CONNECTING ROD	BIELLE	ZEITSTEUERUNGSVE RBINDUNG	BIELA
5	171278GB	BIELLA	CONNECTING ROD	BIELLE	ZEITSTEUERUNGSVE RBINDUNG	BIELA
5	171278H1	BIELLA	CONNECTING ROD	BIELLE	ZEITSTEUERUNGSVE RBINDUNG	BIELA
5	171278H2	BIELLA	CONNECTING ROD	BIELLE	ZEITSTEUERUNGSVE RBINDUNG	BIELA
5	171278J1	BIELLA	CONNECTING ROD	BIELLE	ZEITSTEUERUNGSVE RBINDUNG	BIELA
7	07102200	SPINA	PIN	CHEVILLE	STIF	CLAVIJA
8	07102400	SPINA	PIN	CHEVILLE	STIF	CLAVIJA
9	07095300	SPINA	PIN	CHEVILLE	STIF	CLAVIJA
10	07130500	BOCCOLA 404540	BUSH	DOUILLE	BUCHSE	CASQUILLO
14	171270A1	BIELLA	CONNECTING ROD	BIELLE	ZEITSTEUERUNGSVE RBINDUNG	BIELA
14	171270A3	BIELLA	CONNECTING ROD	BIELLE	ZEITSTEUERUNGSVE RBINDUNG	BIELA



Main color codes:  J1 - JLG Cream,  J2 - JLG Orange,  C4 - Green

 PRIMO BRACCIO

 FIRST ARM

 PREMIER BRAS
ERSTER AUSLEGERARM PRIMO BRAZO 





POS	Codice	 Descrizione	 Description	 Designation	 Benennung	 Descripción
14	171270A5	BIELLA	CONNECTING ROD	BIELLE	ZEITSTEUERUNGSVE RBINDUNG	BIELA
14	171270A7	BIELLA	CONNECTING ROD	BIELLE	ZEITSTEUERUNGSVE RBINDUNG	BIELA
14	171270A9	BIELLA	CONNECTING ROD	BIELLE	ZEITSTEUERUNGSVE RBINDUNG	BIELA
14	171270AG	BIELLA	CONNECTING ROD	BIELLE	ZEITSTEUERUNGSVE RBINDUNG	BIELA
14	171270B1	BIELLA	CONNECTING ROD	BIELLE	ZEITSTEUERUNGSVE RBINDUNG	BIELA
14	171270B9	BIELLA	CONNECTING ROD	BIELLE	ZEITSTEUERUNGSVE RBINDUNG	BIELA
14	171270BC	BIELLA	CONNECTING ROD	BIELLE	ZEITSTEUERUNGSVE RBINDUNG	BIELA
14	171270BP	BIELLA	CONNECTING ROD	BIELLE	ZEITSTEUERUNGSVE RBINDUNG	BIELA
14	171270C4	BIELLA	CONNECTING ROD	BIELLE	ZEITSTEUERUNGSVE RBINDUNG	BIELA
14	171270D1	BIELLA	CONNECTING ROD	BIELLE	ZEITSTEUERUNGSVE RBINDUNG	BIELA
14	171270D5	BIELLA	CONNECTING ROD	BIELLE	ZEITSTEUERUNGSVE RBINDUNG	BIELA
14	171270DI	BIELLA	CONNECTING ROD	BIELLE	ZEITSTEUERUNGSVE RBINDUNG	BIELA
14	171270DT	BIELLA	CONNECTING ROD	BIELLE	ZEITSTEUERUNGSVE RBINDUNG	BIELA
14	171270FC	BIELLA	CONNECTING ROD	BIELLE	ZEITSTEUERUNGSVE RBINDUNG	BIELA
14	171270FX	BIELLA	CONNECTING ROD	BIELLE	ZEITSTEUERUNGSVE RBINDUNG	BIELA
14	171270GB	BIELLA	CONNECTING ROD	BIELLE	ZEITSTEUERUNGSVE RBINDUNG	BIELA
14	171270H1	BIELLA	CONNECTING ROD	BIELLE	ZEITSTEUERUNGSVE RBINDUNG	BIELA



Main color codes:  J1 - JLG Cream,  J2 - JLG Orange,  C4 - Green

 PRIMO BRACCIO

 FIRST ARM

 PREMIER BRAS
ERSTER AUSLEGERARM PRIMO BRAZO 





POS	Codice	 Descrizione	 Description	 Designation	 Benennung	 Descripción
14	171270H2	BIELLA	CONNECTING ROD	BIELLE	ZEITSTEUERUNGSVE RBINDUNG	BIELA
14	171270J1	BIELLA	CONNECTING ROD	BIELLE	ZEITSTEUERUNGSVE RBINDUNG	BIELA
15	371286A1	RINVIO 1° - 2° BRACCIO	1° - 2° ARM TRANSMISSION	RENVOI 1° - 2° BRAS	VORGELEGE 1°-2° ARM	REENVIO 1° - 2° BRAZO
15	371286A3	RINVIO 1° - 2° BRACCIO	1° - 2° ARM TRANSMISSION	RENVOI 1° - 2° BRAS	VORGELEGE 1°-2° ARM	REENVIO 1° - 2° BRAZO
15	371286A5	RINVIO 1° - 2° BRACCIO	1° - 2° ARM TRANSMISSION	RENVOI 1° - 2° BRAS	VORGELEGE 1°-2° ARM	REENVIO 1° - 2° BRAZO
15	371286A7	RINVIO 1° - 2° BRACCIO	1° - 2° ARM TRANSMISSION	RENVOI 1° - 2° BRAS	VORGELEGE 1°-2° ARM	REENVIO 1° - 2° BRAZO
15	371286A9	RINVIO 1° - 2° BRACCIO	1° - 2° ARM TRANSMISSION	RENVOI 1° - 2° BRAS	VORGELEGE 1°-2° ARM	REENVIO 1° - 2° BRAZO
15	371286AG	RINVIO 1° - 2° BRACCIO	1° - 2° ARM TRANSMISSION	RENVOI 1° - 2° BRAS	VORGELEGE 1°-2° ARM	REENVIO 1° - 2° BRAZO
15	371286B1	RINVIO 1° - 2° BRACCIO	1° - 2° ARM TRANSMISSION	RENVOI 1° - 2° BRAS	VORGELEGE 1°-2° ARM	REENVIO 1° - 2° BRAZO
15	371286B9	RINVIO 1° - 2° BRACCIO	1° - 2° ARM TRANSMISSION	RENVOI 1° - 2° BRAS	VORGELEGE 1°-2° ARM	REENVIO 1° - 2° BRAZO
15	371286BC	RINVIO 1° - 2° BRACCIO	1° - 2° ARM TRANSMISSION	RENVOI 1° - 2° BRAS	VORGELEGE 1°-2° ARM	REENVIO 1° - 2° BRAZO
15	371286BP	RINVIO 1° - 2° BRACCIO	1° - 2° ARM TRANSMISSION	RENVOI 1° - 2° BRAS	VORGELEGE 1°-2° ARM	REENVIO 1° - 2° BRAZO
15	371286C4	RINVIO 1° - 2° BRACCIO	1° - 2° ARM TRANSMISSION	RENVOI 1° - 2° BRAS	VORGELEGE 1°-2° ARM	REENVIO 1° - 2° BRAZO
15	371286D1	RINVIO 1° - 2° BRACCIO	1° - 2° ARM TRANSMISSION	RENVOI 1° - 2° BRAS	VORGELEGE 1°-2° ARM	REENVIO 1° - 2° BRAZO
15	371286D5	RINVIO 1° - 2° BRACCIO	1° - 2° ARM TRANSMISSION	RENVOI 1° - 2° BRAS	VORGELEGE 1°-2° ARM	REENVIO 1° - 2° BRAZO
15	371286DI	RINVIO 1° - 2° BRACCIO	1° - 2° ARM TRANSMISSION	RENVOI 1° - 2° BRAS	VORGELEGE 1°-2° ARM	REENVIO 1° - 2° BRAZO
15	371286DT	RINVIO 1° - 2° BRACCIO	1° - 2° ARM TRANSMISSION	RENVOI 1° - 2° BRAS	VORGELEGE 1°-2° ARM	REENVIO 1° - 2° BRAZO



Main color codes:  J1 - JLG Cream,  J2 - JLG Orange,  C4 - Green

 PRIMO BRACCIO





 FIRST ARM



 PREMIER BRAS
ERSTER AUSLEGERARM PRIMO BRAZO 

POS	Codice	 Descrizione	 Description	 Designation	 Benennung	 Descripción
15	371286FC	RINVIO 1° - 2° BRACCIO	1° - 2° ARM TRANSMISSION	RENVOI 1° - 2° BRAS	VORGELEGE 1°-2° ARM	REENVIO 1° - 2° BRAZO
15	371286FX	RINVIO 1° - 2° BRACCIO	1° - 2° ARM TRANSMISSION	RENVOI 1° - 2° BRAS	VORGELEGE 1°-2° ARM	REENVIO 1° - 2° BRAZO
15	371286GB	RINVIO 1° - 2° BRACCIO	1° - 2° ARM TRANSMISSION	RENVOI 1° - 2° BRAS	VORGELEGE 1°-2° ARM	REENVIO 1° - 2° BRAZO
15	371286H1	RINVIO 1° - 2° BRACCIO	1° - 2° ARM TRANSMISSION	RENVOI 1° - 2° BRAS	VORGELEGE 1°-2° ARM	REENVIO 1° - 2° BRAZO
15	371286H2	RINVIO 1° - 2° BRACCIO	1° - 2° ARM TRANSMISSION	RENVOI 1° - 2° BRAS	VORGELEGE 1°-2° ARM	REENVIO 1° - 2° BRAZO
15	371286J1	RINVIO 1° - 2° BRACCIO	1° - 2° ARM TRANSMISSION	RENVOI 1° - 2° BRAS	VORGELEGE 1°-2° ARM	REENVIO 1° - 2° BRAZO
17	071531D2	INDICE ALLINEAMENTO	ALIGNMENT INDICATOR	INDICATEUR D'ALIGNEMENT	AUSRICHTUNGSANZE IGE	INDICADOR ALINEACIÓN
18	05849000	PATTINO	SLIDE BLOCK	PATIN	GLEITBLOCK	PATÍN
19	071538H3	STAFFA	BRACKET	ÉTRIER	HALTEBÜGEL	ESTRIBO
20	05427200	LIVELLA	LEVEL	NIVEAU	WASSERWAAGE	NIVEL DE BURBUJA
21	05444800	MOLLA	SPRING	RESSORT	FEDER	MUELLE
22	058832H3	SUPPORTO	SUPPORT	SUPPORT	HALTERUNG	SOPORTE
23	069590H3	PROTEZIONE	PROTECTION	PROTECTION	SCHUTZ	PROTECCIÓN
24	064422Y1	FERMO	RETAINER	ARRÊT	HALTEVORRICHTUNG	BLOQUE
25	068912Y1	PERNO	PIN	GOIJON	ZAPFEN	PERNIO
26	07154000	MANIGLIA	HANDLE	POIGNÉE	GRIFF	MANIJA
27	060372Y2	FERMO	RETAINER	ARRÊT	HALTERUNG	SUJETADOR
28	07107000	SUPPORTO DISTRIBUTORE DX	SUPPORT DISTRIBUTOR DX	TÔLE PLIÉE	BLECH GEBOGEN	SOPORTE DISTRIBUIDOR DX
29	07124400	SUPPORTO DISTRIBUTORE SX	SUPPORT DISTRIBUTOR SX	TÔLE PLIÉE	BLECH GEBOGEN	CHAPA DOBLADA
30	37153600	CARTER PROTEZIONE DISTRIBUTORE BRACCI	COVER FOR DISTRIBUTOR ARMS	CARTER	KURBELGEHÄUSE	CÁRTER





Main color codes:  J1 - JLG Cream,  J2 - JLG Orange,  C4 - Green



 PRIMO BRACCIO FIRST ARM PREMIER BRASERSTER AUSLEGERARM PRIMO BRAZO 



POS	Codice	 Descrizione	 Description	 Designation	 Benennung	 Descripción
30	373142H2	CARTER DISTRIBUTORE BRACCI (FOR LL1775- X17JP-X500AJ MK2 FROM C170000893)	PROTECTION BOOM HYDRAULIC DISTRIBUTOR (FOR LL1775-X17JP-X500AJ MK2 FROM C170000893)	PROTECTION DISTRIBUTEUR (FOR LL1775-X17JP-X500AJ MK2 FROM C170000893)	SCHUTZ VENTILBLOCK (FOR LL1775-X17JP-X500AJ MK2 FROM C170000893)	PROTECCION DISTRIBUIDOR (FOR LL1775-X17JP-X500AJ MK2 FROM C170000893)
31	07153200	COPERCHIO COMANDI PARTE AEREA	COVER AEREA CONTROLS	COUVERCLE	DECKEL	TAPA
31	073144H2	COPERCHIO (FOR LL1775-X17JP-X500AJ MK2 FROM C170000893)	COVER (FOR LL1775- X17JP-X500AJ MK2 FROM C170000893)	COUVERTURE (FOR LL1775-X17JP-X500AJ MK2 FROM C170000893)	DECKUNG (FOR LL1775-X17JP-X500AJ MK2 FROM C170000893)	COBERTURA (FOR LL1775-X17JP-X500AJ MK2 FROM C170000893)
31	075059H2	COPERCHIO SENZA CHIAVE VERSIONE ANSI (FOR LL1775- X17JP-X500AJ MK2 FROM C170000893)	COVER WITHOUT KEY ANSI VERSION (FOR LL1775-X17JP- X500AJ MK2 FROM C170000893)	COUVERTURE SANS CLÉ (FOR LL1775- X17JP-X500AJ MK2 FROM C170000893)	DECKUNG OHNE SCHLÜSSEL (FOR LL1775-X17JP-X500AJ MK2 FROM C170000893)	COBERTURA SIN LLAVE (FOR LL1775- X17JP-X500AJ MK2 FROM C170000893)
31	07506000	COPERCHIO COMANDI PARTE AEREA SENZA CHIAVE VERSIONE ANSI	COVER AEREA CONTROLS WITHOUT KEY ANSI VERSION	COUVERCLE	DECKEL	TAPA
32	07178800	SERRATURA	LOCK	SERRURE	SCHLOSS	CERRADURA
33	07298800	CHIAVE PER SERRATURA POSTAZIONE COMANDO A TERRA	KEY TO THE LOCK ON THE GROUND CONTROL POSITION	CLÉ	SCHLÜSSEL	LLAVE
34	07178700	CERNIERA CON CONTROLLO DELLA POSIZIONE	HINGES WITH POSITION CONTROL	CHARNIÈRE	SCHARNIER	BISAGRA
35	07178900	CAMMA PER SERRATURA DISASSAMENTO 3.2	CAM LOCK FOR OFFSET 3.2	CAME	NOCKEN	LEVA



Main color codes:  J1 - JLG Cream,  J2 - JLG Orange,  C4 - Green

 PRIMO BRACCIO FIRST ARM PREMIER BRASERSTER AUSLEGERARM PRIMO BRAZO 



POS	Codice	 Descrizione	 Description	 Designation	 Benennung	 Descripción
36	073138Y1	SUPPORTO SERRATURA	LOCK SUPPORT	SUPPORT SERRURE	SCHLOSSHALTERUNG	SOPORTE CERRADURA
37	376848H3	SUPPORTO SALDATO (FOR LL1775-X17JP-X500AJ MK2 FROM C170000893)	WELDED SUPPORT (FOR LL1775-X17JP-X500AJ MK2 FROM C170000893)	SUPPORT	HALTERUNG	SOPORTE
38	076847H3	SUPPORTO (FOR LL1775-X17JP-X500AJ MK2 FROM C170000893)	SUPPORT (FOR LL1775-X17JP-X500AJ MK2 FROM C170000893)	SUPPORT	HALTERUNG	SOPORTE
39	072773H3	SUPPORTO (FOR LL1775-X17JP-X500AJ MK2 FROM C170000893)	SUPPORT (FOR LL1775-X17JP-X500AJ MK2 FROM C170000893)	SOUTIEN (FOR LL1775-X17JP-X500AJ MK2 FROM C170000893)	SUPPORT (FOR LL1775-X17JP-X500AJ MK2 FROM C170000893)	APOYO (FOR LL1775-X17JP-X500AJ MK2 FROM C170000893)

Main color codes:  J1 - JLG Cream,  J2 - JLG Orange,  C4 - Green

-  SECONDO BRACCIO
-  SECOND ARM
-  SECOND BRAS

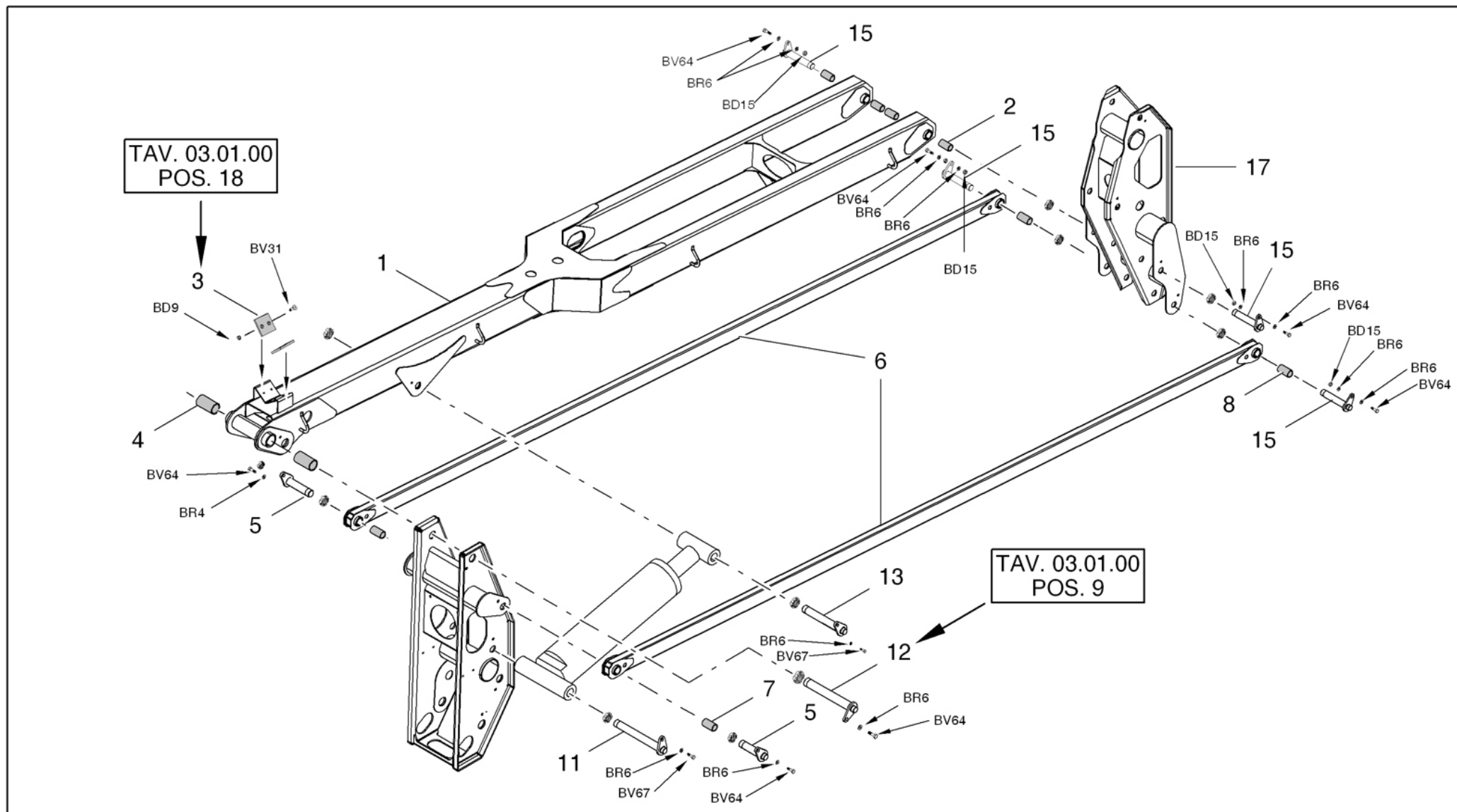
- ZWEITER AUSLEGERARM 
- SEGUNDO BRAZO 











Main color codes:  J1 - JLG Cream,  J2 - JLG Orange,  C4 - Green

 SECONDO BRACCIO

 SECOND ARM

 SECOND BRAS
ZWEITER AUSLEGERARM SEGUNDO BRAZO 

POS	Codice	 Descrizione	 Description	 Designation	 Benennung	 Descripción
1	171246A1	SECONDO BRACCIO COMPLETO	COMPLETE SECOND ARM	DEUXIÈME BRAS COMPLÈTE	ZWEITER ARM ERGÄNZEN	SEGUNDO BRAZO COMPLETO
1	171246A3	SECONDO BRACCIO COMPLETO	COMPLETE SECOND ARM	DEUXIÈME BRAS COMPLÈTE	ZWEITER ARM ERGÄNZEN	SEGUNDO BRAZO COMPLETO
1	171246A5	SECONDO BRACCIO COMPLETO	COMPLETE SECOND ARM	DEUXIÈME BRAS COMPLÈTE	ZWEITER ARM ERGÄNZEN	SEGUNDO BRAZO COMPLETO
1	171246A7	SECONDO BRACCIO COMPLETO	COMPLETE SECOND ARM	DEUXIÈME BRAS COMPLÈTE	ZWEITER ARM ERGÄNZEN	SEGUNDO BRAZO COMPLETO
1	171246A9	SECONDO BRACCIO COMPLETO	COMPLETE SECOND ARM	DEUXIÈME BRAS COMPLÈTE	ZWEITER ARM ERGÄNZEN	SEGUNDO BRAZO COMPLETO
1	171246AG	SECONDO BRACCIO COMPLETO	COMPLETE SECOND ARM	DEUXIÈME BRAS COMPLÈTE	ZWEITER ARM ERGÄNZEN	SEGUNDO BRAZO COMPLETO
1	171246B1	SECONDO BRACCIO COMPLETO	COMPLETE SECOND ARM	DEUXIÈME BRAS COMPLÈTE	ZWEITER ARM ERGÄNZEN	SEGUNDO BRAZO COMPLETO
1	171246B9	SECONDO BRACCIO COMPLETO	COMPLETE SECOND ARM	DEUXIÈME BRAS COMPLÈTE	ZWEITER ARM ERGÄNZEN	SEGUNDO BRAZO COMPLETO
1	171246BC	SECONDO BRACCIO COMPLETO	COMPLETE SECOND ARM	DEUXIÈME BRAS COMPLÈTE	ZWEITER ARM ERGÄNZEN	SEGUNDO BRAZO COMPLETO
1	171246BP	SECONDO BRACCIO COMPLETO	COMPLETE SECOND ARM	DEUXIÈME BRAS COMPLÈTE	ZWEITER ARM ERGÄNZEN	SEGUNDO BRAZO COMPLETO
1	171246C4	SECONDO BRACCIO COMPLETO	COMPLETE SECOND ARM	DEUXIÈME BRAS COMPLÈTE	ZWEITER ARM ERGÄNZEN	SEGUNDO BRAZO COMPLETO
1	171246D1	SECONDO BRACCIO COMPLETO	COMPLETE SECOND ARM	DEUXIÈME BRAS COMPLÈTE	ZWEITER ARM ERGÄNZEN	SEGUNDO BRAZO COMPLETO
1	171246D5	SECONDO BRACCIO COMPLETO	COMPLETE SECOND ARM	DEUXIÈME BRAS COMPLÈTE	ZWEITER ARM ERGÄNZEN	SEGUNDO BRAZO COMPLETO
1	171246DI	SECONDO BRACCIO COMPLETO	COMPLETE SECOND ARM	DEUXIÈME BRAS COMPLÈTE	ZWEITER ARM ERGÄNZEN	SEGUNDO BRAZO COMPLETO
1	171246DT	SECONDO BRACCIO COMPLETO	COMPLETE SECOND ARM	DEUXIÈME BRAS COMPLÈTE	ZWEITER ARM ERGÄNZEN	SEGUNDO BRAZO COMPLETO
1	171246FC	SECONDO BRACCIO COMPLETO	COMPLETE SECOND ARM	DEUXIÈME BRAS COMPLÈTE	ZWEITER ARM ERGÄNZEN	SEGUNDO BRAZO COMPLETO
1	171246FX	SECONDO BRACCIO COMPLETO	COMPLETE SECOND ARM	DEUXIÈME BRAS COMPLÈTE	ZWEITER ARM ERGÄNZEN	SEGUNDO BRAZO COMPLETO





Main color codes:  J1 - JLG Cream,  J2 - JLG Orange,  C4 - Green





 SECONDO BRACCIO

 SECOND ARM

 SECOND BRAS
ZWEITER AUSLEGERARM SEGUNDO BRAZO 





POS	Codice	 Descrizione	 Description	 Designation	 Benennung	 Descripción
1	171246GB	SECONDO BRACCIO COMPLETO	COMPLETE SECOND ARM	DEUXIÈME BRAS COMPLÈTE	ZWEITER ARM ERGÄNZEN	SEGUNDO BRAZO COMPLETO
1	171246H1	SECONDO BRACCIO COMPLETO	COMPLETE SECOND ARM	DEUXIÈME BRAS COMPLÈTE	ZWEITER ARM ERGÄNZEN	SEGUNDO BRAZO COMPLETO
1	171246H2	SECONDO BRACCIO COMPLETO	COMPLETE SECOND ARM	DEUXIÈME BRAS COMPLÈTE	ZWEITER ARM ERGÄNZEN	SEGUNDO BRAZO COMPLETO
1	171246J1	SECONDO BRACCIO COMPLETO	COMPLETE SECOND ARM	DEUXIÈME BRAS COMPLÈTE	ZWEITER ARM ERGÄNZEN	SEGUNDO BRAZO COMPLETO
2	06326300	BOCCOLA	BUSH	DOUILLE	BUCHSE	CASQUILLO
4	06422000	BOCCOLA	BUSH	DOUILLE	BUCHSE	CASQUILLO
5	07095100	SPINA	PIN	CHEVILLE	STIF	CLAVIJA
6	171273A1	BIELLA	CONNECTING ROD	BIELLE	ZEITSTEUERUNGSVE RBINDUNG	BIELA
6	171273A3	BIELLA	CONNECTING ROD	BIELLE	ZEITSTEUERUNGSVE RBINDUNG	BIELA
6	171273A5	BIELLA	CONNECTING ROD	BIELLE	ZEITSTEUERUNGSVE RBINDUNG	BIELA
6	171273A7	BIELLA	CONNECTING ROD	BIELLE	ZEITSTEUERUNGSVE RBINDUNG	BIELA
6	171273A9	BIELLA	CONNECTING ROD	BIELLE	ZEITSTEUERUNGSVE RBINDUNG	BIELA
6	171273AG	TIRANTE	CONNECTING ROD	BIELLE	ZEITSTEUERUNGSVE RBINDUNG	BIELA
6	171273B1	BIELLA	CONNECTING ROD	BIELLE	ZEITSTEUERUNGSVE RBINDUNG	BIELA
6	171273B9	BIELLA	CONNECTING ROD	BIELLE	ZEITSTEUERUNGSVE RBINDUNG	BIELA
6	171273BC	BIELLA	CONNECTING ROD	BIELLE	ZEITSTEUERUNGSVE RBINDUNG	BIELA
6	171273BP	BIELLA	CONNECTING ROD	BIELLE	ZEITSTEUERUNGSVE RBINDUNG	BIELA
6	171273C4	BIELLA	CONNECTING ROD	BIELLE	ZEITSTEUERUNGSVE RBINDUNG	BIELA



Main color codes:  J1 - JLG Cream,  J2 - JLG Orange,  C4 - Green

 SECONDO BRACCIO

 SECOND ARM

 SECOND BRAS
ZWEITER AUSLEGERARM SEGUNDO BRAZO 





POS	Codice	 Descrizione	 Description	 Designation	 Benennung	 Descripción
6	171273D1	TIRANTE	CONNECTING ROD	BIELLE	ZEITSTEUERUNGSVE RBINDUNG	BIELA
6	171273D5	TIRANTE	CONNECTING ROD	BIELLE	ZEITSTEUERUNGSVE RBINDUNG	BIELA
6	171273DI	BIELLA	CONNECTING ROD	BIELLE	ZEITSTEUERUNGSVE RBINDUNG	BIELA
6	171273DT	BIELLA	CONNECTING ROD	BIELLE	ZEITSTEUERUNGSVE RBINDUNG	BIELA
6	171273FC	BIELLA	CONNECTING ROD	BIELLE	ZEITSTEUERUNGSVE RBINDUNG	BIELA
6	171273FX	BIELLA	CONNECTING ROD	BIELLE	ZEITSTEUERUNGSVE RBINDUNG	BIELA
6	171273GB	BIELLA	CONNECTING ROD	BIELLE	ZEITSTEUERUNGSVE RBINDUNG	BIELA
6	171273H1	BIELLA	CONNECTING ROD	BIELLE	ZEITSTEUERUNGSVE RBINDUNG	BIELA
6	171273H2	BIELLA	CONNECTING ROD	BIELLE	ZEITSTEUERUNGSVE RBINDUNG	BIELA
6	171273J1	BIELLA	CONNECTING ROD	BIELLE	ZEITSTEUERUNGSVE RBINDUNG	BIELA
7	06586200	BOCCOLA	BUSH	DOUILLE	BUCHSE	CASQUILLO
8	06422200	BOCCOLA	BUSH	DOUILLE	BUCHSE	CASQUILLO
11	07102300	SPINA	PIN	CHEVILLE	STIF	CLAVIJA
13	07095200	SPINA	PIN	CHEVILLE	STIF	CLAVIJA
15	07095000	SPINA	PIN	CHEVILLE	STIF	CLAVIJA
17	371038A1	RINVIO SECONDO- TERZO BRACCIO	TRANSMISSION SECOND-THIRD ARM	REFERENCE DU DEUXIÈME TROISIEME BRAS	REFERENCE ZWEITEN BIS DRITTEN ARM	REFERENCIA DE SEGUNDA TERCERA ARM
17	371038A3	RINVIO SECONDO- TERZO BRACCIO	TRANSMISSION SECOND-THIRD ARM	REFERÊNCIA ARM SEGUNDA TERCEIRA	REFERENCE DU DEUXIÈME TROISIEME BRAS	REFERENCE ZWEITEN BIS DRITTEN ARM
17	371038A5	RINVIO SECONDO- TERZO BRACCIO	TRANSMISSION SECOND-THIRD ARM	REFERENCE DU DEUXIEME TROISIEME BRAS	REFERENCE ZWEITEN BIS DRITTEN ARM	REFERENCIA DE SEGUNDA TERCERA ARM



Main color codes:  J1 - JLG Cream,  J2 - JLG Orange,  C4 - Green

 SECONDO BRACCIO

 SECOND ARM

 SECOND BRAS
ZWEITER AUSLEGERARM SEGUNDO BRAZO 





POS	Codice	 Descrizione	 Description	 Designation	 Benennung	 Descripción
17	371038A7	RINVIO SECONDO-TERZO BRACCIO	TRANSMISSION SECOND-THIRD ARM	REFERÊNCIA ARM SEGUNDA TERCEIRA	REFERENCE DU DEUXIÈME TROISIEME BRAS	REFERENCE ZWEITEN BIS DRITTEN ARM
17	371038A9	RINVIO	TRANSMISSION	RENVOI	VORGELEGE	REENVIO
17	371038AG	RINVIO SECONDO-TERZO BRACCIO	TRANSMISSION SECOND-THIRD ARM	REFERÊNCIA ARM SEGUNDA TERCEIRA	REFERENCE DU DEUXIÈME TROISIEME BRAS	REFERENCE ZWEITEN BIS DRITTEN ARM
17	371038B1	RINVIO SECONDO-TERZO BRACCIO	TRANSMISSION SECOND-THIRD ARM	REFERENCE DU DEUXIÈME TROISIEME BRAS	REFERENCE ZWEITEN BIS DRITTEN ARM	REFERENCIA DE SEGUNDA TERCERA ARM
17	371038B9	RINVIO	TRANSMISSION	RENVOI	VORGELEGE	REENVIO
17	371038BC	RINVIO SECONDO-TERZO BRACCIO	TRANSMISSION SECOND-THIRD ARM	REFERÊNCIA ARM SEGUNDA TERCEIRA	REFERENCE DU DEUXIÈME TROISIEME BRAS	REFERENCE ZWEITEN BIS DRITTEN ARM
17	371038BP	RINVIO SECONDO-TERZO BRACCIO	TRANSMISSION SECOND-THIRD ARM	REFERÊNCIA ARM SEGUNDA TERCEIRA	REFERENCE DU DEUXIÈME TROISIEME BRAS	REFERENCE ZWEITEN BIS DRITTEN ARM
17	371038C4	RINVIO SECONDO-TERZO BRACCIO	TRANSMISSION SECOND-THIRD ARM	REFERENCE DU DEUXIÈME TROISIEME BRAS	REFERENCE ZWEITEN BIS DRITTEN ARM	REFERENCIA DE SEGUNDA TERCERA ARM
17	371038D1	RINVIO SECONDO-TERZO BRACCIO	TRANSMISSION SECOND-THIRD ARM	REFERÊNCIA ARM SEGUNDA TERCEIRA	REFERENCE DU DEUXIÈME TROISIEME BRAS	REFERENCE ZWEITEN BIS DRITTEN ARM
17	371038D5	RINVIO SECONDO-TERZO BRACCIO	TRANSMISSION SECOND-THIRD ARM	REFERÊNCIA ARM SEGUNDA TERCEIRA	REFERENCE DU DEUXIÈME TROISIEME BRAS	REFERENCE ZWEITEN BIS DRITTEN ARM
17	371038DI	RINVIO SECONDO-TERZO BRACCIO	TRANSMISSION SECOND-THIRD ARM	REFERENCE DU DEUXIEME TROISIEME BRAS	REFERENCE ZWEITEN BIS DRITTEN ARM	REFERENCIA DE SEGUNDA TERCERA ARM
17	371038DT	RINVIO	TRANSMISSION	RENVOI	VORGELEGE	REENVIO
17	371038FC	RINVIO	TRANSMISSION	RENVOI	VORGELEGE	REENVIO
17	371038FX	RINVIO SECONDO-TERZO BRACCIO	TRANSMISSION SECOND-THIRD ARM	REFERÊNCIA ARM SEGUNDA TERCEIRA	REFERENCE DU DEUXIÈME TROISIEME BRAS	REFERENCE ZWEITEN BIS DRITTEN ARM



Main color codes:  J1 - JLG Cream,  J2 - JLG Orange,  C4 - Green



 SECONDO BRACCIO



 SECOND ARM

 SECOND BRAS
ZWEITER AUSLEGERARM SEGUNDO BRAZO 



POS	Codice	 Descrizione	 Description	 Designation	 Benennung	 Descripción
17	371038GB	RINVIO SECONDO-TERZO BRACCIO	TRANSMISSION SECOND-THIRD ARM	REFERÊNCIA ARM SEGUNDA TERCEIRA	REFERENCE DU DEUXIÈME TROISIEME BRAS	REFERENCE ZWEITEN BIS DRITTEN ARM
17	371038H1	RINVIO	TRANSMISSION	RENOI	VORGELEGE	REENVIO
17	371038H2	RINVIO SECONDO-TERZO BRACCIO	TRANSMISSION SECOND-THIRD ARM	REFERÊNCIA ARM SEGUNDA TERCEIRA	REFERENCE DU DEUXIÈME TROISIEME BRAS	REFERENCE ZWEITEN BIS DRITTEN ARM
17	371038J1	RINVIO	TRANSMISSION	RENOI	VORGELEGE	REENVIO

**Main color codes:**  J1 - JLG Cream,  J2 - JLG Orange,  C4 - Green



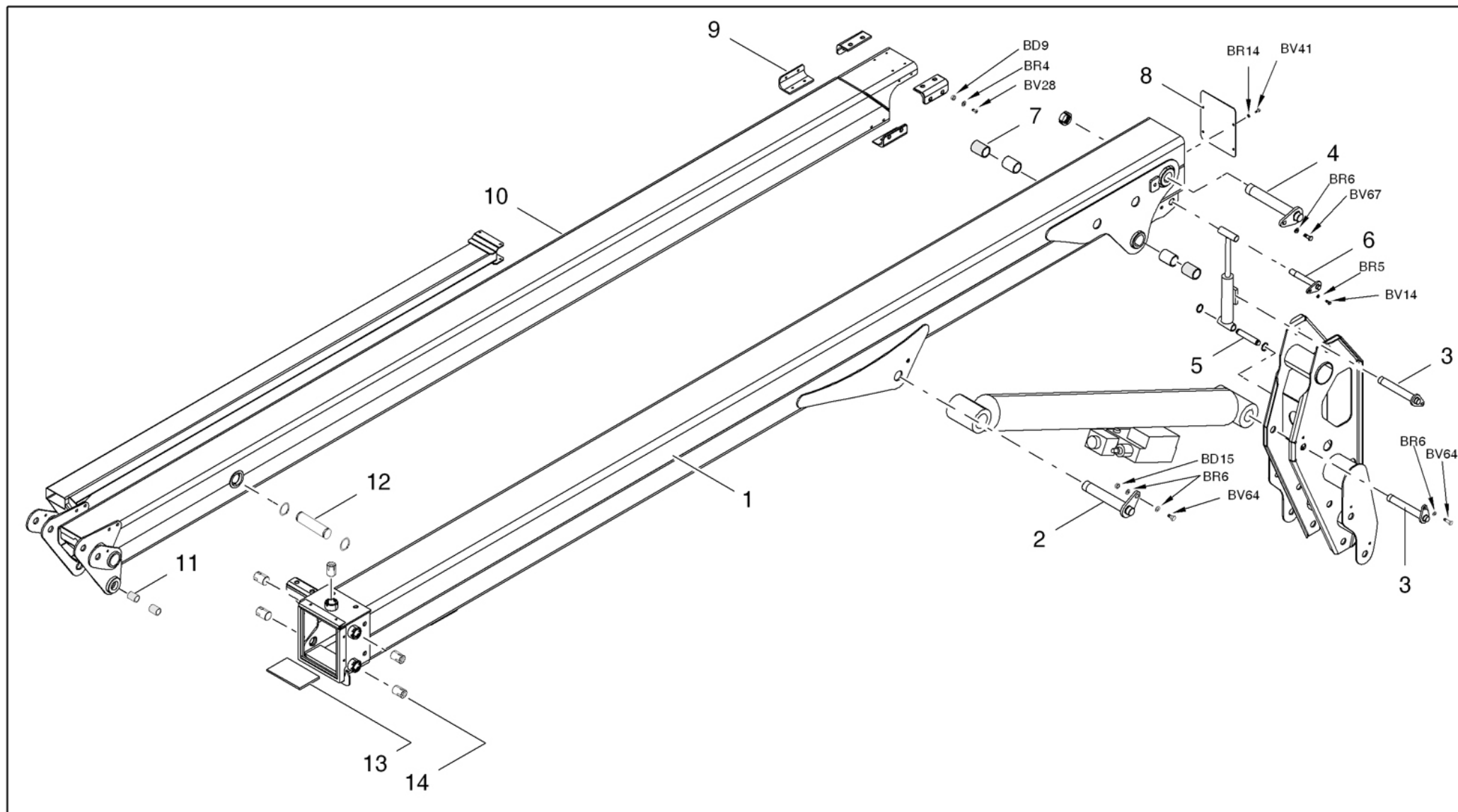

 TERZO BRACCIO  
 THIRD ARM  
 TIERS BRAS



THIRD AUSLEGERARM   
TERCERO BRAZO 



Main color codes:  J1 - JLG Cream,  J2 - JLG Orange,  C4 - Green

 TERZO BRACCIO THIRD ARM TIERS BRASTHIRD AUSLEGERARM TERCERO BRAZO 





POS	Codice	 Descrizione	 Description	 Designation	 Benennung	 Descripción
1	170955A1	TERZO BRACCIO COMPLETO	COMPLETE THIRD ARM	COMPLETE TROISIÈME BRAS	KOMPLETTE DRITTEN ARM	TERCER BRAZO COMPLETO
1	170955A3	TERZO BRACCIO COMPLETO	COMPLETE THIRD ARM	COMPLETE TROISIÈME BRAS	KOMPLETTE DRITTEN ARM	TERCER BRAZO COMPLETO
1	170955A5	TERZO BRACCIO COMPLETO	COMPLETE THIRD ARM	COMPLETE TROISIÈME BRAS	KOMPLETTE DRITTEN ARM	TERCER BRAZO COMPLETO
1	170955A7	TERZO BRACCIO COMPLETO	COMPLETE THIRD ARM	COMPLETE TROISIÈME BRAS	KOMPLETTE DRITTEN ARM	TERCER BRAZO COMPLETO
1	170955A9	TERZO BRACCIO COMPLETO	COMPLETE THIRD ARM	COMPLETE TROISIÈME BRAS	KOMPLETTE DRITTEN ARM	TERCER BRAZO COMPLETO
1	170955AG	TERZO BRACCIO COMPLETO	COMPLETE THIRD ARM	COMPLETE TROISIÈME BRAS	KOMPLETTE DRITTEN ARM	TERCER BRAZO COMPLETO
1	170955B1	TERZO BRACCIO COMPLETO	COMPLETE THIRD ARM	COMPLETE TROISIÈME BRAS	KOMPLETTE DRITTEN ARM	TERCER BRAZO COMPLETO
1	170955B9	TERZO BRACCIO COMPLETO	COMPLETE THIRD ARM	COMPLETE TROISIÈME BRAS	KOMPLETTE DRITTEN ARM	TERCER BRAZO COMPLETO
1	170955BC	TERZO BRACCIO COMPLETO	COMPLETE THIRD ARM	COMPLETE TROISIÈME BRAS	KOMPLETTE DRITTEN ARM	TERCER BRAZO COMPLETO
1	170955BP	TERZO BRACCIO COMPLETO	COMPLETE THIRD ARM	COMPLETE TROISIÈME BRAS	KOMPLETTE DRITTEN ARM	TERCER BRAZO COMPLETO
1	170955C4	TERZO BRACCIO COMPLETO	COMPLETE THIRD ARM	COMPLETE TROISIÈME BRAS	KOMPLETTE DRITTEN ARM	TERCER BRAZO COMPLETO
1	170955D1	TERZO BRACCIO COMPLETO	COMPLETE THIRD ARM	COMPLETE TROISIÈME BRAS	KOMPLETTE DRITTEN ARM	TERCER BRAZO COMPLETO
1	170955D5	TERZO BRACCIO COMPLETO	COMPLETE THIRD ARM	COMPLETE TROISIÈME BRAS	KOMPLETTE DRITTEN ARM	TERCER BRAZO COMPLETO
1	170955DI	TERZO BRACCIO COMPLETO	COMPLETE THIRD ARM	COMPLETE TROISIÈME BRAS	KOMPLETTE DRITTEN ARM	TERCER BRAZO COMPLETO
1	170955DT	TERZO BRACCIO COMPLETO	COMPLETE THIRD ARM	COMPLETE TROISIÈME BRAS	KOMPLETTE DRITTEN ARM	TERCER BRAZO COMPLETO
1	170955FC	TERZO BRACCIO COMPLETO	COMPLETE THIRD ARM	COMPLETE TROISIÈME BRAS	KOMPLETTE DRITTEN ARM	TERCER BRAZO COMPLETO
1	170955FX	TERZO BRACCIO COMPLETO	COMPLETE THIRD ARM	COMPLETE TROISIÈME BRAS	KOMPLETTE DRITTEN ARM	TERCER BRAZO COMPLETO



Main color codes:  J1 - JLG Cream,  J2 - JLG Orange,  C4 - Green

 TERZO BRACCIO

 THIRD ARM

 TIERS BRAS
THIRD AUSLEGERARM TERCERO BRAZO 





POS	Codice	 Descrizione	 Description	 Designation	 Benennung	 Descripción
1	170955GB	TERZO BRACCIO COMPLETO	COMPLETE THIRD ARM	COMPLETE TROISIÈME BRAS	KOMPLETTE DRITTEN ARM	TERCER BRAZO COMPLETO
1	170955H1	TERZO BRACCIO COMPLETO	COMPLETE THIRD ARM	COMPLETE TROISIÈME BRAS	KOMPLETTE DRITTEN ARM	TERCER BRAZO COMPLETO
1	170955H2	TERZO BRACCIO COMPLETO	COMPLETE THIRD ARM	COMPLETE TROISIÈME BRAS	KOMPLETTE DRITTEN ARM	TERCER BRAZO COMPLETO
1	170955J1	TERZO BRACCIO COMPLETO	COMPLETE THIRD ARM	COMPLETE TROISIÈME BRAS	KOMPLETTE DRITTEN ARM	TERCER BRAZO COMPLETO
2	07093900	SPINA	PIN	CHEVILLE	STIF	CLAVIJA
3	07094900	SPINA	PIN	CHEVILLE	STIF	CLAVIJA
4	07102500	SPINA	PIN	CHEVILLE	STIF	CLAVIJA
5	06867600	SPINA	PIN	CHEVILLE	STIFT	CLAVIJA
6	06230600	SPINA	PIN	CHEVILLE	STIFT	CLAVIJA
7	06326300	BOCCOLA	BUSH	DOUILLE	BUCHSE	CASQUILLO
8	071315H3	COPERCHIO POSTERIORE SFILO	BACK COVER EXTENSION	COUVERCLE	DECKEL	TAPA
9	07178200	PATTINO	SLIDE BLOCK	PATIN	GLEITBLOCK	PATÍN
10	171049A1	BRACCIO SFILO COMPLETO	COMPLETE ARM EXTENSION	BRAS EXTENSION COMPLÈTE	ARM ERWEITERUNG ERGÄNZEN	BRAZO EXTENSIÓN COMPLETO
10	171049A3	BRACCIO SFILO COMPLETO	COMPLETE ARM EXTENSION	BRAS EXTENSION COMPLÈTE	ARM ERWEITERUNG ERGÄNZEN	BRAZO EXTENSIÓN COMPLETO
10	171049A5	BRACCIO SFILO COMPLETO	COMPLETE ARM EXTENSION	BRAS EXTENSION COMPLÈTE	ARM ERWEITERUNG ERGÄNZEN	BRAZO EXTENSIÓN COMPLETO
10	171049A7	BRACCIO SFILO COMPLETO	COMPLETE ARM EXTENSION	BRAS EXTENSION COMPLÈTE	ARM ERWEITERUNG ERGÄNZEN	BRAZO EXTENSIÓN COMPLETO
10	171049A9	BRACCIO SFILO COMPLETO	COMPLETE ARM EXTENSION	BRAS EXTENSION COMPLÈTE	ARM ERWEITERUNG ERGÄNZEN	BRAZO EXTENSIÓN COMPLETO
10	171049AG	BRACCIO SFILO COMPLETO	COMPLETE ARM EXTENSION	BRAS EXTENSION COMPLÈTE	ARM ERWEITERUNG ERGÄNZEN	BRAZO EXTENSIÓN COMPLETO
10	171049B1	BRACCIO SFILO COMPLETO	COMPLETE ARM EXTENSION	BRAS EXTENSION COMPLÈTE	ARM ERWEITERUNG ERGÄNZEN	BRAZO EXTENSIÓN COMPLETO
10	171049B9	BRACCIO SFILO COMPLETO	COMPLETE ARM EXTENSION	BRAS EXTENSION COMPLÈTE	ARM ERWEITERUNG ERGÄNZEN	BRAZO EXTENSIÓN COMPLETO



Main color codes:  J1 - JLG Cream,  J2 - JLG Orange,  C4 - Green

 TERZO BRACCIO



 THIRD ARM



 TIERS BRAS
THIRD AUSLEGERARM TERCERO BRAZO 

POS	Codice	 Descrizione	 Description	 Designation	 Benennung	 Descripción
10	171049BC	BRACCIO SFILO COMPLETO	COMPLETE ARM EXTENSION	BRAS EXTENSION COMPLÈTE	ARM ERWEITERUNG ERGÄNZEN	BRAZO EXTENSIÓN COMPLETO
10	171049BP	BRACCIO SFILO COMPLETO	COMPLETE ARM EXTENSION	BRAS EXTENSION COMPLÈTE	ARM ERWEITERUNG ERGÄNZEN	BRAZO EXTENSIÓN COMPLETO
10	171049C4	BRACCIO SFILO COMPLETO	COMPLETE ARM EXTENSION	BRAS EXTENSION COMPLÈTE	ARM ERWEITERUNG ERGÄNZEN	BRAZO EXTENSIÓN COMPLETO
10	171049D1	BRACCIO SFILO COMPLETO	COMPLETE ARM EXTENSION	BRAS EXTENSION COMPLÈTE	ARM ERWEITERUNG ERGÄNZEN	BRAZO EXTENSIÓN COMPLETO
10	171049D4	BRACCIO SFILO COMPLETO	COMPLETE ARM EXTENSION	BRAS EXTENSION COMPLÈTE	ARM ERWEITERUNG ERGÄNZEN	BRAZO EXTENSIÓN COMPLETO
10	171049DI	BRACCIO SFILO COMPLETO	COMPLETE ARM EXTENSION	BRAS EXTENSION COMPLÈTE	ARM ERWEITERUNG ERGÄNZEN	BRAZO EXTENSIÓN COMPLETO
10	171049DT	BRACCIO SFILO COMPLETO	COMPLETE ARM EXTENSION	BRAS EXTENSION COMPLÈTE	ARM ERWEITERUNG ERGÄNZEN	BRAZO EXTENSIÓN COMPLETO
10	171049FC	BRACCIO SFILO COMPLETO	COMPLETE ARM EXTENSION	BRAS EXTENSION COMPLÈTE	ARM ERWEITERUNG ERGÄNZEN	BRAZO EXTENSIÓN COMPLETO
10	171049FX	BRACCIO SFILO COMPLETO	COMPLETE ARM EXTENSION	BRAS EXTENSION COMPLÈTE	ARM ERWEITERUNG ERGÄNZEN	BRAZO EXTENSIÓN COMPLETO
10	171049GB	BRACCIO SFILO COMPLETO	COMPLETE ARM EXTENSION	BRAS EXTENSION COMPLÈTE	ARM ERWEITERUNG ERGÄNZEN	BRAZO EXTENSIÓN COMPLETO
10	171049H1	BRACCIO SFILO COMPLETO	COMPLETE ARM EXTENSION	BRAS EXTENSION COMPLÈTE	ARM ERWEITERUNG ERGÄNZEN	BRAZO EXTENSIÓN COMPLETO
10	171049H2	BRACCIO SFILO COMPLETO	COMPLETE ARM EXTENSION	BRAS EXTENSION COMPLÈTE	ARM ERWEITERUNG ERGÄNZEN	BRAZO EXTENSIÓN COMPLETO
10	171049J2	BRACCIO SFILO COMPLETO	COMPLETE ARM EXTENSION	BRAS EXTENSION COMPLÈTE	ARM ERWEITERUNG ERGÄNZEN	BRAZO EXTENSIÓN COMPLETO
11	06900700	BOCCOLA	BUSH	DOUILLE	BUCHSE	CASQUILLO
12	06853800	SPINA	PIN	CHEVILLE	STIF	CLAVIJA
13	07101100	PATTINO	SLIDE BLOCK	PATIN	GLEITBLOCK	PATÍN
14	05804700	PATTINO	SLIDE BLOCK	PATIN	GLEITBLOCK	PATÍN
14	06958600	PATTINO	SLIDE BLOCK	PATIN	GLEITBLOCK	PATÍN



Main color codes:  J1 - JLG Cream,  J2 - JLG Orange,  C4 - Green

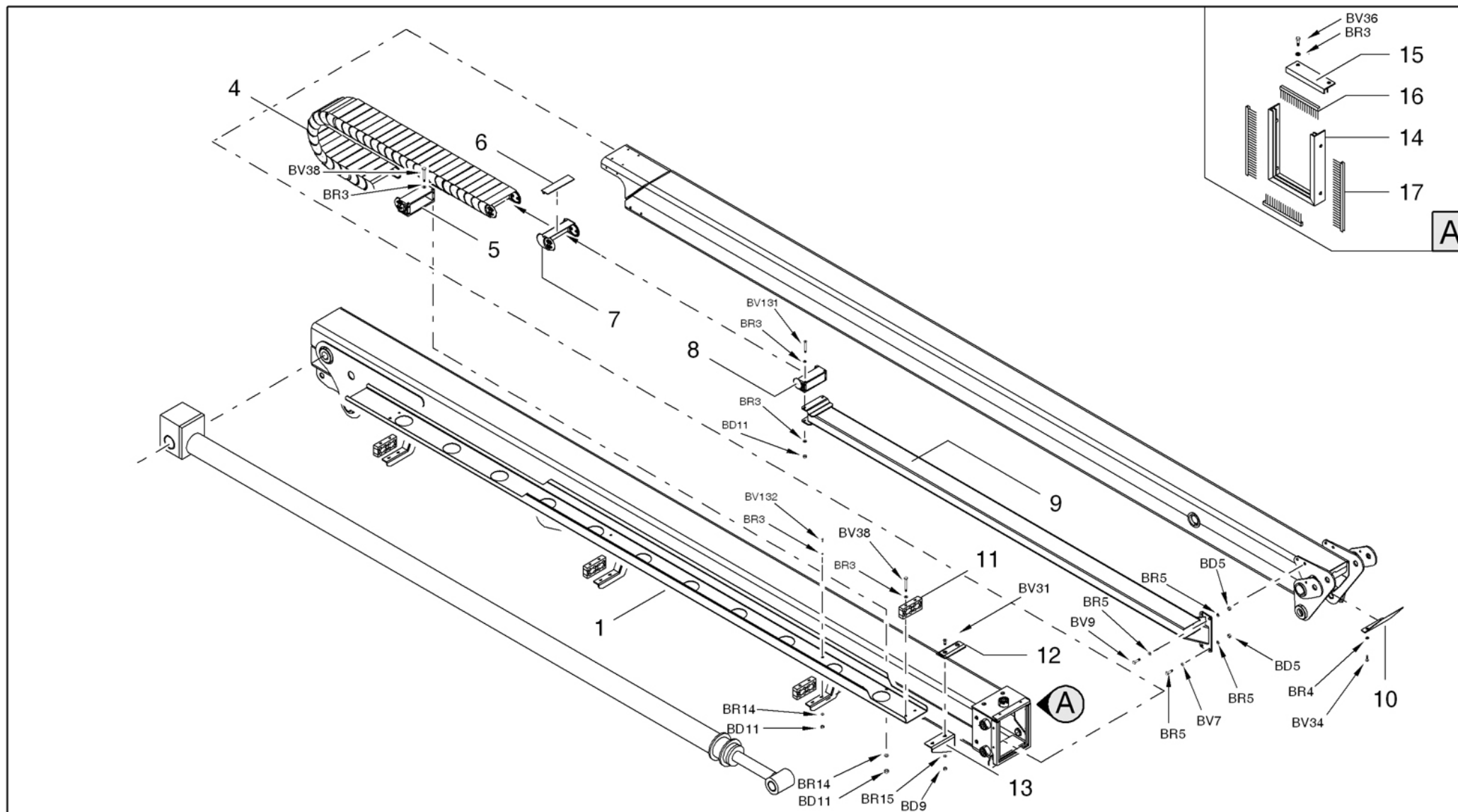

 CATENA PORTACAVI FLESSIBILE  
 FLEXIBLE CABLE-HOLDER CHAIN  
 CHAÎNE PORTE-CABLES FLEXIBLE

SCHLAUCH SCHLEPPKETTE   
 CADENA PORTACABLES FLEXIBLE 



Main color codes:  J1 - JLG Cream,  J2 - JLG Orange,  C4 - Green





 CATENA PORTACAVI FLESSIBILE



 FLEXIBLE CABLE-HOLDER CHAIN

 CHAÎNE PORTE-CABLES FLEXIBLE

 SCHLAUCH SCHLEPPKETTE

 CADENA PORTACABLES FLEXIBLE

POS	Codice	 Descrizione	 Description	 Designation	 Benennung	 Descripción
1	071005H3	SUPPORTO	SUPPORT	SUPPORT	HALTERUNG	SOPORTE
4	25950500	CATENA PORTACAVI	CABLE-HOLDER CHAIN	CHAÎNE PORTE-CÂBLES	KABELHALTERKETTE	CADENA PORTACABLES
5	2595050001	MAGLIA CATENA ATTACCO FEMMINA	CHAIN LINK FEMALE CONNECTION	MAILLOT CHAÎNE	KETTENGLIED	ESLABÓN CADENA
6	2595050004	COPERCHIO	COVER	COUVERCLE	DECKEL	TAPA
7	2595050003	MAGLIA CATENA	CHAIN LINK	MAILLOT CHAÎNE	KETTENGLIED	ESLABÓN CADENA
8	2595050002	MAGLIA CATENA ATTACCO MASCHIO	CHAIN LINK MALE CONNECTION	MAILLOT CHAÎNE	KETTENGLIED	ESLABÓN CADENA
9	371307H3	SUPPORTO	SUPPORT	SUPPORT	HALTERUNG	SOPORTE
10	071314H3	COPERCHIO ANTERIORE SFILO	FRONT COVER EXTENSION	COUVERCLE	DECKEL	TAPA
11	07100600	MORSETTO	CLAMP	BORNE	KLEMME	BORNE
11	07874100	MORSETTO	CLAMP	BORNE	KLEMME	BORNE
12	068663H3	SUPPORTO	SUPPORT	SUPPORT	HALTERUNG	SOPORTE
13	06867100	PATTINO	SLIDE BLOCK	PATIN	GLEITBLOCK	PATÍN
14	07101500	PROFILO SPAZZOLE	PROFILE BRUSHES	TÔLE PLIÉE	BLECH GEBOGEN	CHAPA DOBLADA
14	17101500	KIT SPAZZOLE TERZO BRACCIO LL2010	BRUSHES KIT	KIT BROSSES	BÜRSTENSATZ	KIT CEPILLOS
15	07101600	PROFILO SPAZZOLE SUPERIORE	PROFILE BRUSH TOP	CHÂSSIS	RAHMEN	BASTIDOR
16	07102000	SPAZZOLA ORRIZONTALE	HORIZONTAL BRUSH	BROSSE HORIZONTALE	WAAGRECHTE BÜRSTE	CEPILLO HORIZONTAL
17	07102100	SPAZZOLA VERTICALE	VERTICAL BRUSH	BROSSE VERTICALE	SENKRECHTE BÜRSTE	CEPILLO VERTICAL

**Main color codes:**  J1 - JLG Cream,  J2 - JLG Orange,  C4 - Green

🇮🇹 SUPPORTO CESTO

🇬🇧 BASKET SUPPORT

🇫🇷 PANIER CUPPORT

HALTERUNG ARBEITSKORB 🇩🇪



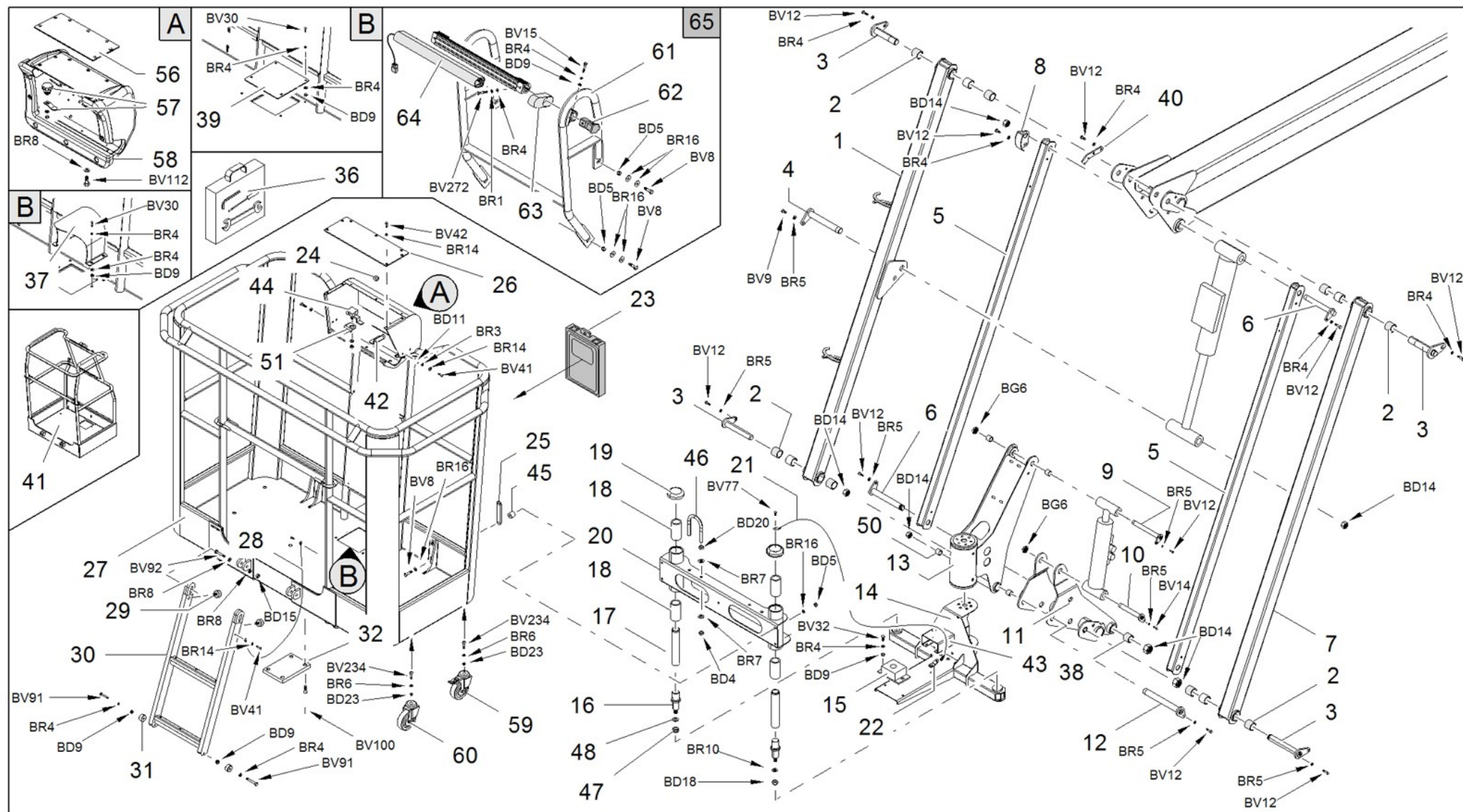

SOPORTE CESTA 🇪🇸







 SUPPORTO CESTO





 BASKET SUPPORT



 PANIER CUPPORT
HALTERUNG ARBEITSKORB SOPORTE CESTA 

POS	Codice	 Descrizione	 Description	 Designation	 Benennung	 Descripción
1	170948A1	BRACCIO JIB COMPLETO	COMPLETE JIB ARM	FLÉCHETTE BRAS COMPLÈTE	ARM - SCHWENKARM	BRAZO JIB COMPLETO
1	170948A2	BRACCIO JIB COMPLETO	COMPLETE JIB ARM	FLÉCHETTE BRAS COMPLÈTE	ARM - SCHWENKARM	BRAZO JIB COMPLETO
1	170948A3	BRACCIO JIB COMPLETO	COMPLETE JIB ARM	FLÉCHETTE BRAS COMPLÈTE	ARM - SCHWENKARM	BRAZO JIB COMPLETO
1	170948A5	BRACCIO JIB COMPLETO	COMPLETE JIB ARM	FLÉCHETTE BRAS COMPLÈTE	ARM - SCHWENKARM	BRAZO JIB COMPLETO
1	170948A7	BRACCIO JIB COMPLETO	COMPLETE JIB ARM	FLÉCHETTE BRAS COMPLÈTE	ARM - SCHWENKARM	BRAZO JIB COMPLETO
1	170948A9	BRACCIO JIB COMPLETO	COMPLETE JIB ARM	FLÉCHETTE BRAS COMPLÈTE	ARM - SCHWENKARM	BRAZO JIB COMPLETO
1	170948AG	BRACCIO JIB COMPLETO DX	COMPLETE JIB ARM RIGHT	BRAS JIB DROITE COMPLÈTE	KORBARM RECHTS	BRAZO JIB DERECHA COMPLETO
1	170948B1	BRACCIO JIB COMPLETO	COMPLETE JIB ARM	FLÉCHETTE BRAS COMPLÈTE	ARM - SCHWENKARM	BRAZO JIB COMPLETO
1	170948B9	BRACCIO JIB COMPLETO	COMPLETE JIB ARM	FLÉCHETTE BRAS COMPLÈTE	ARM - SCHWENKARM	BRAZO JIB COMPLETO
1	170948BC	BRACCIO JIB COMPLETO	COMPLETE JIB ARM	FLÉCHETTE BRAS COMPLÈTE	ARM - SCHWENKARM	BRAZO JIB COMPLETO
1	170948BP	BRACCIO JIB COMPLETO	COMPLETE JIB ARM	FLÉCHETTE BRAS COMPLÈTE	ARM - SCHWENKARM	BRAZO JIB COMPLETO
1	170948C4	BRACCIO JIB COMPLETO	COMPLETE JIB ARM	FLÉCHETTE BRAS COMPLÈTE	ARM - SCHWENKARM	BRAZO JIB COMPLETO
1	170948D4	BRACCIO JIB COMPLETO	COMPLETE JIB ARM	FLÉCHETTE BRAS COMPLÈTE	ARM - SCHWENKARM	BRAZO JIB COMPLETO
1	170948DI	BRACCIO JIB COMPLETO	COMPLETE JIB ARM	FLÉCHETTE BRAS COMPLÈTE	ARM - SCHWENKARM	BRAZO JIB COMPLETO
1	170948DT	BRACCIO JIB COMPLETO	COMPLETE JIB ARM	FLÉCHETTE BRAS COMPLÈTE	ARM - SCHWENKARM	BRAZO JIB COMPLETO
1	170948FC	BRACCIO JIB COMPLETO	COMPLETE JIB ARM	FLÉCHETTE BRAS COMPLÈTE	ARM - SCHWENKARM	BRAZO JIB COMPLETO
1	170948FX	BRACCIO JIB COMPLETO	COMPLETE JIB ARM	FLÉCHETTE BRAS COMPLÈTE	ARM - SCHWENKARM	BRAZO JIB COMPLETO





Main color codes:  J1 - JLG Cream,  J2 - JLG Orange,  C4 - Green



 SUPPORTO CESTO BASKET SUPPORT PANIER CUPPORTHALTERUNG ARBEITSKORB SOPORTE CESTA 

POS	Codice	 Descrizione	 Description	 Designation	 Benennung	 Descripción
1	170948GB	BRACCIO JIB COMPLETO	COMPLETE JIB ARM	FLÉCHETTE BRAS COMPLÈTE	ARM - SCHWENKARM	BRAZO JIB COMPLETO
1	170948H1	BRACCIO JIB COMPLETO	COMPLETE JIB ARM	FLÉCHETTE BRAS COMPLÈTE	ARM - SCHWENKARM	BRAZO JIB COMPLETO
1	170948H2	BRACCIO JIB COMPLETO	COMPLETE JIB ARM	FLÉCHETTE BRAS COMPLÈTE	ARM - SCHWENKARM	BRAZO JIB COMPLETO
1	170948J2	BRACCIO JIB COMPLETO DX	COMPLETE JIB ARM RIGHT	BRAS JIB DROITE COMPLÈTE	KORBARM RECHTS	BRAZO JIB DERECHA COMPLETO
2	06272600	BOCCOLA	BUSH	DOUILLE	BUCHSE	CASQUILLO
3	07093500	SPINA	PIN	CHEVILLE	STIFT	CLAVIJA
4	07093800	SPINA	PIN	CHEVILLE	STIFT	CLAVIJA
5	359447A1	TIRANTE	TIE ROD	TIRANT	TURMGESTÄNGE	TIRANTE
5	359447A2	TIRANTE	TIE ROD	TIRANT	TURMGESTÄNGE	TIRANTE
5	359447A3	TIRANTE	TIE ROD	TIRANT	TURMGESTÄNGE	TIRANTE
5	359447A5	TIRANTE	TIE ROD	TIRANT	TURMGESTÄNGE	TIRANTE
5	359447A7	TIRANTE	TIE ROD	TIRANT	TURMGESTÄNGE	TIRANTE
5	359447A9	TIRANTE	TIE ROD	TIRANT	TURMGESTÄNGE	TIRANTE
5	359447AG	TIRANTE JIB	TIE ROD JIB	TIRANT	ZUGSTANGE	TIRANTE
5	359447B1	TIRANTE	TIE ROD	TIRANT	TURMGESTÄNGE	TIRANTE
5	359447B9	TIRANTE	TIE ROD	TIRANT	TURMGESTÄNGE	TIRANTE
5	359447BC	TIRANTE	TIE ROD	TIRANT	TURMGESTÄNGE	TIRANTE
5	359447BP	TIRANTE	TIE ROD	TIRANT	TURMGESTÄNGE	TIRANTE
5	359447C4	TIRANTE	TIE ROD	TIRANT	TURMGESTÄNGE	TIRANTE
5	359447D4	TIRANTE	TIE ROD	TIRANT	TURMGESTÄNGE	TIRANTE
5	359447DI	TIRANTE	TIE ROD	TIRANT	TURMGESTÄNGE	TIRANTE
5	359447DT	TIRANTE	TIE ROD	TIRANT	TURMGESTÄNGE	TIRANTE
5	359447FC	TIRANTE	TIE ROD	TIRANT	TURMGESTÄNGE	TIRANTE
5	359447FX	TIRANTE	TIE ROD	TIRANT	TURMGESTÄNGE	TIRANTE
5	359447GB	TIRANTE	TIE ROD	TIRANT	TURMGESTÄNGE	TIRANTE
5	359447H1	TIRANTE	TIE ROD	TIRANT	TURMGESTÄNGE	TIRANTE
5	359447H2	TIRANTE	TIE ROD	TIRANT	TURMGESTÄNGE	TIRANTE
5	359447J2	TIRANTE JIB	TIE ROD JIB	TIRANT	ZUGSTANGE	TIRANTE
6	07093600	SPINA	PIN	CHEVILLE	STIFT	CLAVIJA





Main color codes:  J1 - JLG Cream,  J2 - JLG Orange,  C4 - Green



 SUPPORTO CESTO BASKET SUPPORT PANIER CUPPORTHALTERUNG ARBEITSKORB SOPORTE CESTA 

POS	Codice	 Descrizione	 Description	 Designation	 Benennung	 Descripción
7	170947A1	BRACCIO JIB COMPLETO	COMPLETE JIB ARM	FLÉCHETTE BRAS COMPLÈTE	ARM - SCHWENKARM	BRAZO JIB COMPLETO
7	170947A2	BRACCIO JIB COMPLETO	COMPLETE JIB ARM	FLÉCHETTE BRAS COMPLÈTE	ARM - SCHWENKARM	BRAZO JIB COMPLETO
7	170947A3	BRACCIO JIB COMPLETO	COMPLETE JIB ARM	FLÉCHETTE BRAS COMPLÈTE	ARM - SCHWENKARM	BRAZO JIB COMPLETO
7	170947A5	BRACCIO JIB COMPLETO	COMPLETE JIB ARM	FLÉCHETTE BRAS COMPLÈTE	ARM - SCHWENKARM	BRAZO JIB COMPLETO
7	170947A7	BRACCIO JIB COMPLETO	COMPLETE JIB ARM	FLÉCHETTE BRAS COMPLÈTE	ARM - SCHWENKARM	BRAZO JIB COMPLETO
7	170947A9	BRACCIO JIB COMPLETO	COMPLETE JIB ARM	FLÉCHETTE BRAS COMPLÈTE	ARM - SCHWENKARM	BRAZO JIB COMPLETO
7	170947AG	BRACCIO JIB COMPLETO SX	COMPLETE JIB ARM LEFT	BRAS JIB GAUCHE	KORBARM LINKS	BRAZO JIB IZQUIERDA
7	170947B1	BRACCIO JIB COMPLETO	COMPLETE JIB ARM	FLÉCHETTE BRAS COMPLÈTE	ARM - SCHWENKARM	BRAZO JIB COMPLETO
7	170947B9	BRACCIO JIB COMPLETO	COMPLETE JIB ARM	FLÉCHETTE BRAS COMPLÈTE	ARM - SCHWENKARM	BRAZO JIB COMPLETO
7	170947BC	BRACCIO JIB COMPLETO	COMPLETE JIB ARM	FLÉCHETTE BRAS COMPLÈTE	ARM - SCHWENKARM	BRAZO JIB COMPLETO
7	170947BP	BRACCIO JIB COMPLETO	COMPLETE JIB ARM	FLÉCHETTE BRAS COMPLÈTE	ARM - SCHWENKARM	BRAZO JIB COMPLETO
7	170947C4	BRACCIO JIB COMPLETO	COMPLETE JIB ARM	FLÉCHETTE BRAS COMPLÈTE	ARM - SCHWENKARM	BRAZO JIB COMPLETO
7	170947D4	BRACCIO JIB COMPLETO	COMPLETE JIB ARM	FLÉCHETTE BRAS COMPLÈTE	ARM - SCHWENKARM	BRAZO JIB COMPLETO
7	170947DI	BRACCIO JIB COMPLETO	COMPLETE JIB ARM	FLÉCHETTE BRAS COMPLÈTE	ARM - SCHWENKARM	BRAZO JIB COMPLETO
7	170947DT	BRACCIO JIB COMPLETO	COMPLETE JIB ARM	FLÉCHETTE BRAS COMPLÈTE	ARM - SCHWENKARM	BRAZO JIB COMPLETO
7	170947FC	BRACCIO JIB COMPLETO	COMPLETE JIB ARM	FLÉCHETTE BRAS COMPLÈTE	ARM - SCHWENKARM	BRAZO JIB COMPLETO
7	170947FX	BRACCIO JIB COMPLETO	COMPLETE JIB ARM	FLÉCHETTE BRAS COMPLÈTE	ARM - SCHWENKARM	BRAZO JIB COMPLETO

Main color codes:  J1 - JLG Cream,  J2 - JLG Orange,  C4 - Green

 SUPPORTO CESTO BASKET SUPPORT PANIER CUPPORTHALTERUNG ARBEITSKORB SOPORTE CESTA 





POS	Codice	 Descrizione	 Description	 Designation	 Benennung	 Descripción
7	170947GB	BRACCIO JIB COMPLETO	COMPLETE JIB ARM	FLÉCHETTE BRAS COMPLÈTE	ARM - SCHWENKARM	BRAZO JIB COMPLETO
7	170947H1	BRACCIO JIB COMPLETO	COMPLETE JIB ARM	FLÉCHETTE BRAS COMPLÈTE	ARM - SCHWENKARM	BRAZO JIB COMPLETO
7	170947H2	BRACCIO JIB COMPLETO	COMPLETE JIB ARM	FLÉCHETTE BRAS COMPLÈTE	ARM - SCHWENKARM	BRAZO JIB COMPLETO
7	170947J2	BRACCIO JIB COMPLETO SX	COMPLETE JIB ARM LEFT	BRAS JIB GAUCHE	KORBARM LINKS	BRAZO JIB IZQUIERDA
8	372264H3	CAMMA MICRO JIB	MICROSWITCH CAM JIB	CAME	NOCKEN	LEVA
9	07093700	SPINA	PIN	CHEVILLE	STIFT	CLAVIJA
10	06235600	SPINA	PIN	CHEVILLE	STIFT	CLAVIJA
11	166242A1	RINVIO	TRANSMISSION	RENVOI	VORGELEGE	REENVIO
11	166242A2	RINVIO	TRANSMISSION	RENVOI	VORGELEGE	REENVIO
11	166242A3	RINVIO	TRANSMISSION	RENVOI	VORGELEGE	REENVIO
11	166242A5	RINVIO	TRANSMISSION	RENVOI	VORGELEGE	REENVIO
11	166242A7	RINVIO	TRANSMISSION	RENVOI	VORGELEGE	REENVIO
11	166242A9	RINVIO	TRANSMISSION	RENVOI	VORGELEGE	REENVIO
11	166242AG	RINVIO JIB	UPRIGHT JIB	RENVOI	VORGELEGE	REENVIO
11	166242B1	RINVIO	TRANSMISSION	RENVOI	VORGELEGE	REENVIO
11	166242B9	RINVIO	TRANSMISSION	RENVOI	VORGELEGE	REENVIO
11	166242BC	RINVIO	TRANSMISSION	RENVOI	VORGELEGE	REENVIO
11	166242BP	RINVIO	TRANSMISSION	RENVOI	VORGELEGE	REENVIO
11	166242C4	RINVIO	TRANSMISSION	RENVOI	VORGELEGE	REENVIO
11	166242D4	RINVIO	TRANSMISSION	RENVOI	VORGELEGE	REENVIO
11	166242DI	RINVIO	TRANSMISSION	RENVOI	VORGELEGE	REENVIO
11	166242DT	RINVIO	TRANSMISSION	RENVOI	VORGELEGE	REENVIO
11	166242FC	RINVIO	TRANSMISSION	RENVOI	VORGELEGE	REENVIO
11	166242FX	RINVIO	TRANSMISSION	RENVOI	VORGELEGE	REENVIO
11	166242GB	RINVIO	TRANSMISSION	RENVOI	VORGELEGE	REENVIO
11	166242H1	RINVIO	TRANSMISSION	RENVOI	VORGELEGE	REENVIO
11	166242H2	RINVIO	TRANSMISSION	RENVOI	VORGELEGE	REENVIO
11	166242J2	RINVIO JIB	UPRIGHT JIB	RENVOI	VORGELEGE	REENVIO



Main color codes:  J1 - JLG Cream,  J2 - JLG Orange,  C4 - Green

 SUPPORTO CESTO

 BASKET SUPPORT

 PANIER CUPPORT
HALTERUNG ARBEITSKORB SOPORTE CESTA 

POS	Codice	 Descrizione	 Description	 Designation	 Benennung	 Descripción
12	06235700	SPINA	PIN	CHEVILLE	STIFT	CLAVIJA
13	2648910002	KIT GUARNIZIONI	SEAL KIT	KIT DE JOINTS	DICHTUNGSSATZ	KIT DE JUNTAS
13	271778A1	MOTORE DI ROTAZIONE	ROTARY MOTOR	MOTEUR DE ROTATION	MOTORDREHZAHL	MOTOR ROTACIÓN
13	271778A7	ATTUATORE ROTANTE	ROTARY MOTOR	ROTARY ACTUATOR	SCHWENKEINHEIT	ACTUADOR ROTATIVO
13	271778B1	ATTUATORE ROTANTE	ROTARY MOTOR	ROTARY ACTUATOR	SCHWENKEINHEIT	ACTUADOR ROTATIVO
13	271778H2	MOTORE DI ROTAZIONE	ROTARY MOTOR	MOTEUR DE ROTATION	DREHANTRIEB	MOTOR ROTACIÓN
13	271778J0	MOTORE DI ROTAZIONE	ROTARY MOTOR	MOTEUR DE ROTATION	ROTATIONSMOTOR	MOTOR DE ROTACIÓN
14	07766500	PERNO INCERNIERAMENTO MENSOLA SUPPORTO CESTO	PIN HINGE BRACKET SUPPORT BASKET	AXE	STIFT	PERNIO
14	07771500	MANIGLIA	HANDLE	POIGNÉE	GRIFF	MANIJA
14	371463A1	ASSIEME SUPPORTO CESTO PERNI DIAM.50	TOGETHER SUPPORT PINS BASKET DIAM.50	ENSEMBLE SUPPORT PINS BASKET DIAM.50	TOGETHER AUFLAGESTIFTE BASKET DIAM.50	JUNTOS APOYO PINS CESTA DIAM.50
14	371463A7	ASSIEME SUPPORTO CESTO PERNI DIAM.50	BASKET ASSEMBLY SUPPORT PINS Ø50	ENSEMBLE SUPPORT PANIER	TOGETHER STÜTZKORBS	JUNTOS SOPORTE DE LA CESTA
14	371463B1	ASSIEME SUPPORTO CESTO PERNI DIAM.50	BASKET ASSEMBLY SUPPORT PINS Ø50	ENSEMBLE SUPPORT PANIER	TOGETHER STÜTZKORBS	JUNTOS SOPORTE DE LA CESTA
14	371463H2	ASSIEME SUPPORTO CESTO PERNI DIAM.50	TOGETHER SUPPORT PINS BASKET DIAM.50	ENSEMBLE SUPPORT PINS BASKET DIAM.50	TOGETHER AUFLAGESTIFTE BASKET DIAM.50	JUNTOS APOYO PINS CESTA DIAM.50
14	371463J2	ASSIEME SUPPORTO CESTO PERNI DIAM.50	BASKET SUPPORT ASSEMBLY PINS Ø50	SUPPORT PANIER	KORBHALTERUNG	SOPORTE DE LA CESTA
14	377660H2	SUPPORTO CESTO	BASKET SUPPORT	SUPPORT PANIER	KORBHALTERUNG	SOPORTE CESTA
14	377661H2	MENSOLA SUPPORTO CELLA DI CARICO	BRACKET SUPPORT LOAD CELL	BRIDE SUPPORT CELLULE DE CHARGE	STEIGBÜGELHALTERUNG FÜRLASTÜBERWACHUNG UNGSZELLE	BRIDA SOPORTE CELULA DE CARGA

Main color codes:  J1 - JLG Cream,  J2 - JLG Orange,  C4 - Green







 SUPPORTO CESTO



 BASKET SUPPORT

 PANIER CUPPORT

 HALTERUNG ARBEITSKORB

 SOPORTE CESTA





POS	Codice	 Descrizione	 Description	 Designation	 Benennung	 Descripción
15	056187H3	COPERCHIO	BOX	COUVERCLE	DECKEL	TAPA
16	07190900	VITE TE DIN960 CI 8.8 M16X1.5X115 FORATA GEOMET321 PLUS XL	TE SCREW DIN960 CI 8.8 M16X1.5X115 GEOMET321 PERFORATED PLUS XL	VIS TE DIN960 CI 8,8 M16X1.5X115 FORE PLUS GEOMET321 XL	TE SCHRAUBE DIN960 CI 8,8 M16X1.5X115 GEOMET321 PERFORATED PLUS XL	TE TORNILLO DIN960 CI 8,8 M16X1.5X115 GEOMET321 PERFORADA XL
17	07146500	PERNO SUPPORTO CESTO DIAM.50	PIN SUPPORT BASKET Ø50	AXE DIAM.50 PANIER DE SOUTIEN	BOLZEN KORBBALTERUNG	CLAVIJA CESTA
18	27146200	CUSCINETTO LINEARE A SFERE 50-100	LINEAR BALL BEARING 50-100	ROULEMENT Á BILLES	LINEAR-KUGELLAGER 50-100	COJINETE DE BOLAS 50-100
19	07146400	TAPPO CHIUSURA PERNI SUPPORTO CESTO DIAM.50	CAP PINS BASKET SUPPORT Ø50	BOUCHON	VERSCHLUSS	TAPÓN
20	371459H2	SLITTA FISSAGGIO CESTO PERNI DIAM.50	SLIDE BASKET MOUNTING BOLTS Ø50	COULISSEAU	SCHLITTEN	CORREDERA
21	06665000	FUNE	CABLE	CÂBLE	SEIL	CABLE
22	07052900	STAFFA	BRACKET	ÉTRIER	HALTEBÜGEL	ESTRIBO
23	05643600	CASSETTA PORTAMANUALE	MANUAL BOX	BOÎTE PORTE-MANUEL	BEDIENUNGSANLEITUNGSFACH	CAJA PORTAMANUAL
24	06477600	MAGNETE Ø20 CON FORO M3	MAGNETO Ø20 WITH M3 HOLE	AIMANT	MAGNET	IMÁN
25	072398H3	PIASTRA FISSAGGIO CESTO (SOLO MACCHINE MODELLO JP E JA E X17J)	FIXING PLATE BASKET (ONLY MACHINES MODEL JP AND JA AND X17J)	PLATE FIXATION DRUM	PLATE BEFESTIGUNG DRUM	PLACA FIJACIÓN TAMBOR
26	07190600	COPERTURA SUPPORTO TELECOMANDO (SOLO MACCHINE MODELLO JP E JA E X17J)	COVER SUPPORT REMOTE CONTROL (ONLY MACHINES MODEL JP AND JA AND X17J)	COUVERTURE SUPPORT DE LA TELECOMMANDE	COVER FERNBEDIENUNGSHALTER	CUBIERTA SOPORTE DE CONTROL REMOTO



**Main color codes:**  J1 - JLG Cream,  J2 - JLG Orange,  C4 - Green

 SUPPORTO CESTO

 BASKET SUPPORT

 PANIER CUPPORT
HALTERUNG ARBEITSKORB SOPORTE CESTA 





POS	Codice	 Descrizione	 Description	 Designation	 Benennung	 Descripción
27	27177700	CESTO BIPOSTO 230KG (SOLO MACCHINE MODELLO JP E JA)	BASKET 2 PERSON 230KG (ONLY MACHINES MODEL JP AND JA)	PANIER 2 PERSONNES	2 MANN- ARBEITSKORB	CESTA 2 PERSONAS
27	27589300	CESTO BIPOSTO 230KG PER MK2 (DA C170000893)	BASKET 2 PERSON 230KG FOR MK2 (FROM C170000893)	PANIER 2 PERSONNES POUR MK2 (FROM C170000893)	2 MANN- ARBEITSKORB FÜR MK2 (FROM C170000893)	CESTA 2 PERSONAS PARA MK2 (FROM C170000893)
27	28250000	CESTO	BASKET	PANIER POUR 2 PERSONNES	2-MANN- ARBEITSKORB	CESTA PARA DOS PERSONAS
27	28372000	CESTO MONOPOSTO LL2614 SKYLINE - NON PREDISPOSTO SKY GUARD	BASKET SINGLE SEAT LL2614 SKYLINE	PANIER MONOPLACE LL2614 SKYLINE	KORB EINZELSITZ LL2614 SKYLINE	CESTO MONOPLAZA LL2614 SKYLINE
28	06598500	FUNE	CABLE	CÂBLE	SEIL	CABLE
30	08558100	TAPPO PER SCALETTA	CAP	BOUCHON	DECKEL	TAPA
30	18478900	SCALETTA	LADDER	EHELLE	LEITER	ESCALERA
32	058600H3	PIASTRA	PLATE	PLAQUE	PLATTE	PLACA
37	06418600	PROTEZIONE	PROTECTION	PROTECTION	SCHUTZ	PROTECCIÓN
40	072263H3	STAFFA	BRACKET	ÉTRIER	HALTEBÜGEL	ESTRIBO
42	071905H3	PIEGATO BLOCCAGGIO TELECOMANDO (SOLO MACCHINE MODELLO JP E JA E X17J)	BENDED LOCKING REMOTE CONTROL (ONLY MACHINES MODEL JP AND JA AND X17J)	BENT BLOCAGE TELECOMMANDE	BENT EINRASTEN FERNBEDIENUNG	BENT BLOQUEO DE CONTROL REMOTO
43	072404H3	SUPPORTO PEDALE	PEDAL SUPPORT PLATE	TÔLE PLIÉE	HALTERUNG	SOPORTE
44	07192700	CHIUSURA A VOLANTINO CON LEVA PIEGATA (SOLO MACCHINE MODELLO JP E JA E X17J)	LOCKING WHEEL WITH BENT LEVER (ONLY MACHINES MODEL JP AND JA AND X17J)	POIGNEE DE BLOCAGE	KUGELVERSCHLUSS	POMO DE BLOQUEO



Main color codes:  J1 - JLG Cream,  J2 - JLG Orange,  C4 - Green

 SUPPORTO CESTO

 BASKET SUPPORT

 PANIER CUPPORT
HALTERUNG ARBEITSKORB SOPORTE CESTA 





POS	Codice	 Descrizione	 Description	 Designation	 Benennung	 Descripción
45	07239700	DISTANZIALE PER VITI M8 SUPPORTO CESTO (SOLO MACCHINE MODELLO JP E JA E X17J)	SPACER SCREW M8 SUPPORT BASKET (ONLY MACHINES MODEL JP AND JA AND X17J)	ENTRETOISE	DISTANZSTÜCK	DISTANCIADOR
46	07031800	TUBO	PIPE	TUYAU	ROHR	TUBO
47	07193000	DADO AD INTAGLI UNI5593 CI 8 M16X1.5 GEOMET321 PLUS XL	NUT M16X1.5 NOTCHES UNI5593 CI 8 GEOMET321 PLUS XL	ÉCROU UNI5593 CI 8 M16X1.5 GEOMET321 PLUS XL	MUTTER UNI5593 CI 8 M16X1.5 GEOMET321 PLUS XL	TUERCA UNI5593 CI 8 M16X1.5 GEOMET321 PLUS XL
48	07192600	RONDELLA SPECIALE HV 300 - D 17X48X6 GEOMET321/A+PLUS XL	SPECIAL WASHER HV 300 - 17X48X6 GEOMET321 D / A + PLUS XL	RONDELLE SPECIALE HV 300 - 17X48X6 GEOMET321 D / A + PLUS XL	SCHEIBE HV 300 - 17X48X6 GEOMET321 D / A + PLUS XL	ARANDELA ESPECIAL HV 300 - 17X48X6 GEOMET321 D / A + PLUS XL
50	06272700	BOCCOLA	BUSH	DOUILLE	BUCHSE	CASQUILLO
51	071908H3	STAFFA FISSAGGIO CHIUSURA BLOCCAGGIO TELECOMANDO (SOLO MACCHINE MODELLO JP E JA E X17J)	BRACKET LOCKING REMOTE CONTROL (ONLY MACHINES MODEL JP AND JA AND X17J)	FIN DE SUPPORT DE BLOCAGE TELECOMMANDE	BRACKET END EINRASTEN FERNBEDIENUNG	SOPORTE DE FIN DE BLOQUEO DE CONTROL REMOTO
56	07690700	PROTEZIONE TRASPARENTE	PROTECTION	PROTECTION	SCHUTZ	PROTECCIÓN
57	07192700	CHIUSURA A VOLANTINO CON LEVA PIEGATA (SOLO MACCHINE MODELLO JP E JA E X17J)	LOCKING WHEEL WITH BENT LEVER (ONLY MACHINES MODEL JP AND JA AND X17J)	POIGNEE DE BLOCAGE	KUGELVERSCHLUSS	POMO DE BLOQUEO
58	17569900	PROTEZIONE TELECOMANDO	PROTECTION REMOTE CONTROL	PROTECTION	SCHUTZ	PROTECCIÓN
59	07751100	RUOTE INFERIORI PER CESTO CON FRENO	LOWER WHEELS FOR BASKET WITH BRAKE	ROUES POUR PANIER	KORBRÄDER	RUEDAS



Main color codes:  J1 - JLG Cream,  J2 - JLG Orange,  C4 - Green

 SUPPORTO CESTO





 BASKET SUPPORT



 PANIER CUPPORT
HALTERUNG ARBEITSKORB SOPORTE CESTA 

POS	Codice	 Descrizione	 Description	 Designation	 Benennung	 Descripción
60	07687300	RUOTE INFERIORI PER CESTO	LOWER WHEEL	ROULEAU INFERIEUR	UNTERES RAD	RUEDA INFERIOR
61	37609800	TELAIO SUPPORTO SKY-GUARD CESTO BIPOSTO	SKY-FRAME SUPPORT GUARD BASKET 2PERSON	CHÂSSIS	RAHMEN	CHASIS
61	37675400	TELAIO SUPPORTO SKY-GUARD CESTO MONOPOSTO	SKY-FRAME SUPPORT GUARD BASKET 1PERSON	CHÂSSIS SUPPORT	RAHMEN HALTERUNG	BASTIDOR SOPORTE
62	07796900	BLOCCHETTO PLASTICA PER FISSAGGIO SKYGUARD (1001188889)	BLOCK PLASTIC FOR SECURING SKYGUARD (1001188889)	BLOC	BLOCK	BLOQUE
63	07797000	COVER IN GOMMA PER PROTEZIONE FISSAGGIO SKY GUARD (1001186517)	COVER RUBBER PROTECTION FOR FIXING SKY GUARD (1001186517)	PROTECTION	SCHUTZ	PROTECCIÓN
63	08310700	COVER DESTRA SKYLINE	SKYLINE RIGHT COVER	COUVERTURE DROITE	RECHTE ABDECKUNG	COBERTURA
63	08310800	COVER SINISTRA SKYLINE	SKYLINE LEFT COVER	COUVERTURE GAUCHE	LINKE ABDECKUNG	COBERTURA IZQUIERDA
64	08132300	BACCHETTA IN FIBRA DI VETRO	GLASS FIBER WAND	BAGUETTE EN FIBRE DE VERRE	GLASFASERSTAB	VARILLA DE FIBRA DE VIDRIO
64	18310600	MICRO	MICRO WITH WIRING	MICROINTERRPTEUR	MIKROSCHALTER	MICROINTERRUPTOR
64	27796800	SENSORE SKYGUARD	SENSOR SKYGUARD	CAPTEUR	SENSOR	SENSOR
65	17768100	KIT SKY GUARD COMPLETO BIPOSTO PER CCBS	SKYGUARD COMPLETE KIT FOR 2 PERSON CCBS	KIT SKY GUARD	SKY GUARD SATZ	KIT SKY GUARD
65	17768300	KIT SKY GUARD COMPLETO MONOPOSTO PER CCBS	SKYGUARD COMPLETE KIT FOR SINGLE PERSON CCBS	KIT SKY GUARD	SATZ SKY GUARD	KIT SKY GUARD

Main color codes:  J1 - JLG Cream,  J2 - JLG Orange,  C4 - Green

 SUPPORTO CESTO BASKET SUPPORT PANIER CUPPORTHALTERUNG ARBEITSKORB SOPORTE CESTA 

POS	Codice	 Descrizione	 Description	 Designation	 Benennung	 Descripción
65	18357200	KIT SKY LINE SU ATTACCO SKY GUARD MACCHINE JLG	CABLE ANTI- ENTRAPMENT SYSTEM	SYSTEME ANTI- ECRASEMENT AVEC CABLE	KABLE-ANTI- QUETSCH- VORRICHTUNG	SISTEMA ANTIAPLASTAMIENT O CON CABLE
65	18357300	KIT SKY LINE COMPLETO BIPOSTO HINOWA	SKYLINE COMPLETE KIT FOR 2 PERSON DSE PLATFORM	KIT SKY LINE	SKY LINE SATZ	KIT SKY LINE
66	07093600	SPINA	PIN	CHEVILLE	STIFT	CLAVIJA

Main color codes:  J1 - JLG Cream,  J2 - JLG Orange,  C4 - Green



 ACCOPPIAMENTO MOTORE DIESEL- POMPA



 DIESEL ENGINE COUPLING - PUMP

 ACCOUPLEMENT MOTEUR DIESEL - POMPE

PUMPEN / DIESELMOTOR KUPPLUNG 

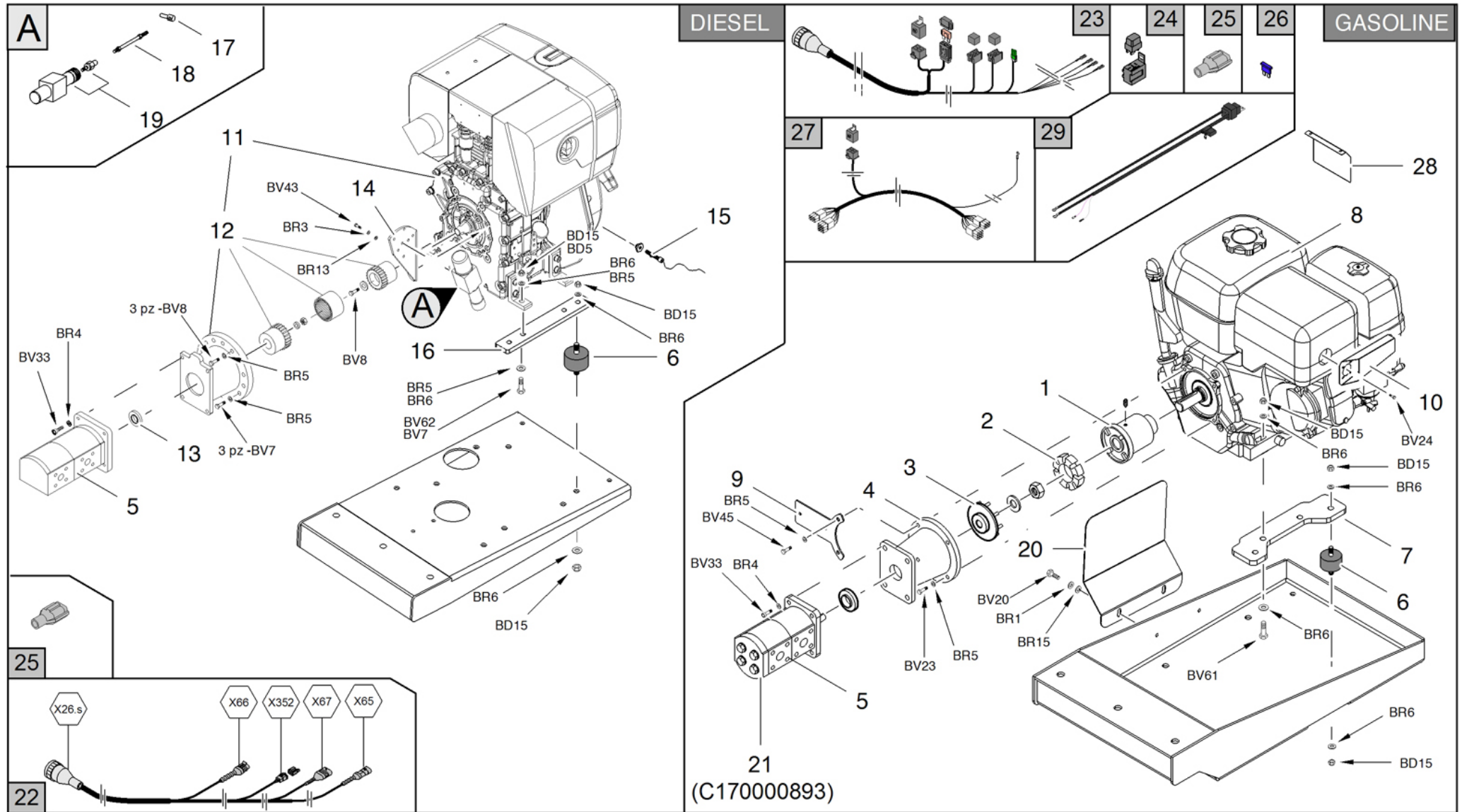
ACOPLAMIENTO MOTOR DIESEL- BOMBA 



Main color codes:  J1 - JLG Cream,  J2 - JLG Orange,  C4 - Green





 ACCOPPIAMENTO MOTORE DIESEL- POMPA

 DIESEL ENGINE COUPLING - PUMP

 ACCOUPLEMENT MOTEUR DIESEL - POMPE

 PUMPEN / DIESELMOTOR KUPPLUNG

 ACOPLAMIENTO MOTOR DIESEL- BOMBA



POS	Codice	 Descrizione	 Description	 Designation	 Benennung	 Descripción
1	055591Y2	DISTANZIALE	SPACER	ENTRETOISE	DISTANZSTÜCK	DISTANCIADOR
2	04310100	INSERTO IN GOMMA	RUBBER INSERT	INSERT EN CAOUTCHOUC	GUMMIEINSATZ	INSERTO DE GOMA
3	04615300	GIUNTO	COUPLING	JOINT	VERBINDUNG	ACOPLAMIENTO
4	04310300	LANTERNA	LANTERN	LANTERNE	LANTERNE	LINTERNA
5	146152H3	POMPA IDRAULICA	HYDRAULIC PUMP	POMPE HYDRAULIQUE	HYDRAULIKPUMPE	BOMBA HYDRÁULICA
6	04152400	ANTIVIBRANTE VERSIONE DIESEL	ANTI-VIBRATING DIESEL VERSION	ANTI - VIBRANT	VIBRATIONS DÄMPFER	ANTIVIBRANTE
6	05535300	ANTIVIBRANTE VERSIONE BENZINA	ANTI-VIBRATING GASOLINE VERSION	ANTI - VIBRANT	VIBRATIONS DÄMPFER	ANTIVIBRANTE
7	046393H3	SUPPORTO MOTORE HONDA GX390	SUPPORT ENGINE HONDA GX390	SUPPORT HONDA GX390	HALTERUNG HONDA GX390	SOPORTE HONDA GX390
7	059551H2	PIATTO HONDA IGX440	PLATE HONDA IGX440	PLATEAU HONDA IGX440	PLATTE HONDA IGX440	PLACA HONDA IGX440
8	25952600	MOTORE BENZINA	PETROL ENGINE	MOTEUR A ESSÉNCÉ	BENZINMOTOR	MOTOR DE GASOLINA
8	27775900	MOTORE HONDA IGX390 MODIFICATO SENZA BLOCCHETTO CHIAVE DI ACCENSIONE MK2 (DA C170000893)	HONDA MOTOR IGX390 MODIFIED WITHOUT IGNITION SWITCH MK2 (FROM C170000893)	MOTEUR HONDA IGX390	HONDA MOTOR IGX390	MOTOR HONDA IGX390
9	061177H2	STAFFA	BRACKET	ÉTRIER	HALTEBÜGEL	ESTRIBO
10	059220Y1	DEFLETTORE	DEFLECTOR	DÉFLECTEUR	ABWEISER	DEFLECTOR
11	27110400	MOTORE DIESEL HATZ 10HP VERSIONE CON PREDISPOSIZIONE REGOLAZIONI GIRI ELETTRONICA (NO CARB-EPA CERT)	HATZ DIESEL ENGINE 10HP VERSION WITH PREDISPOSITION TO ELECTRONIC SPEED REGULATION (NO CARB-EPA CERT)	MOTEUR DIESEL	DIESELMOTOR	MOTOR DIESEL











 ACCOPPIAMENTO MOTORE DIESEL- POMPA

 DIESEL ENGINE COUPLING - PUMP

 ACCOUPLEMENT MOTEUR DIESEL - POMPE

 PUMPEN / DIESELMOTOR KUPPLUNG   
 ACOPLAMIENTO MOTOR DIESEL- BOMBA 





POS	Codice	 Descrizione	 Description	 Designation	 Benennung	 Descripción
11	27676900	MOTORE DIESEL HATZ 1B40 RPM SENZA CHIAVE+ACCOPPIAMENTO (TIER3 SOLO VERS. EU, NO CARB-EPA CERT) MK2 (DA C170000893)	DIESEL ENGINE HATZ 1B40 RPM WITHOUT KEY + COUPLING (TIER3 ONLY VERS. EU, NON-EPA CARB CERT) MK2 (FROM C170000893)	MOTEUR DIESEL HATZ	HATZ DIESEL MOTOR	MOTOR DIESEL HATZ
12	2558630001	ACCOPPIAMENTO MOTORE - POMPA	ENGINE COUPLING - PUMP	ACCOUPLEMENT MOTEUR - POMPE	PUMPEN-/MOTORKUPPLUNG	ACOPLAMIENTO MOTOR - BOMBA
13	04310200	SEMIGIUNTO	HALF COUPLING	DEMI-JOINT	HALBVERBINDUNG	SEMI-ACOPLAMIENTO
14	070989H2	STAFFA	BRACKET	ÉTRIER	HALTEBÜGEL	HALTEBÜGEL
15	26514900	SENSORE	SENSOR	CAPTEUR	SENSOR	SENSOR
16	057900Y1	PIATTO	PLATE	PLATEAU	PLATTE	PLACA
17	070986Y2	PERNO	PIN	GOIJON	ZAPFEN	PERNIO
18	07098700	TIRANTE	TIE ROD	TIRANT	TURMGESTÄNGE	TIRANTE
19	26551500	PISTONE	PISTON	PISTON	KOLBEN	PISTÓN
20	061907H2	PROTEZIONE	PROTECTION	PROTECTION	SCHUTZ	PROTECCIÓN
21	284674H3	POMPA IDRAULICA	HYDRAULIC PUMP	POMPE HYDRAULIQUE	HYDRAULIKPUMPE	BOMBA HYDRÁULICA
22	1764270001	KIT IMPIANTO ELETTRICO A RICAMBIO DIESEL LL1775 MK2 (DA C170000893)	KIT ELECTRICAL SPARE FOR DIESEL LL1775 MK2 (FROM C170000893)	KIT INSTALLATION ÉLECTRIQUE	ELEKTRO-EINBAUSATZ	KIT INSTALACIÓN ELÉCTRICA
23	1776330002	KIT IMPIANTO ELETTRICO A RICAMBIO BENZINA 13I LL1775 MK2 (DA C170000893)	KIT ELECTRICAL SPARE FOR GASOLINE 13I LL1775 MK2 (FROM C170000893)	KIT INSTALLATION ÉLECTRIQUE	ELEKTROSATZ	KIT INSTALACIÓN ELÉCTRICA
24	1776330003	RELE' MINI TYCO 12V PER CONNETTORE A TENUTA (MK2 DA C170000893)	RELAY 'MINI 12V TYCO CONNECTOR SEAL (MK2 FROM C170000893)	RELAIS	RELAIS	RELÉ



 Main color codes:  J1 - JLG Cream,  J2 - JLG Orange,  C4 - Green



 ACCOPPIAMENTO MOTORE DIESEL- POMPA

 DIESEL ENGINE COUPLING - PUMP



 ACCOUPLEMENT MOTEUR DIESEL - POMPE
PUMPEN / DIESELMOTOR KUPPLUNG ACOPLAMIENTO MOTOR DIESEL- BOMBA 



POS	Codice	 Descrizione	 Description	 Designation	 Benennung	 Descripción
25	1757250022	TAPPO CONNETTORE YAZAKI 2 VIE CON DIODO 1.5A	PLUG	BOUCHON	DECKEL	TAPA
26	05760700	FUSIBILE A LAMA 5A	FUSE 5A	FUSIBLE 5A	SICHERUNG 5A	FUSIBLE 5A
27	17535700	KIT RELE' AGGIUNTIVO PER SPEGNIMENTO MOTORE HONDA IGX440	ADDITIONAL RELAY KIT FOR POWER-OFF HONDA MOTOR IGX440	RELAIS	RELAIS	RELÉ
27	17965000	KIT RELE' AGGIUNTIVO SEGNAL MOTORE ACCESO HONDA IGX390	KIT RELAY 'ADDITIONAL SIGNAL ON HONDA MOTOR IGX390	KIT RELAIS	RELAIS KIT	KIT RELÉ
28	07798300	PROTEZIONE CARBURATORE LL1775	CARBURETOR PROTECTION FOR LL1775	PROTECTION	SCHTUZ	PROTECCIÓN

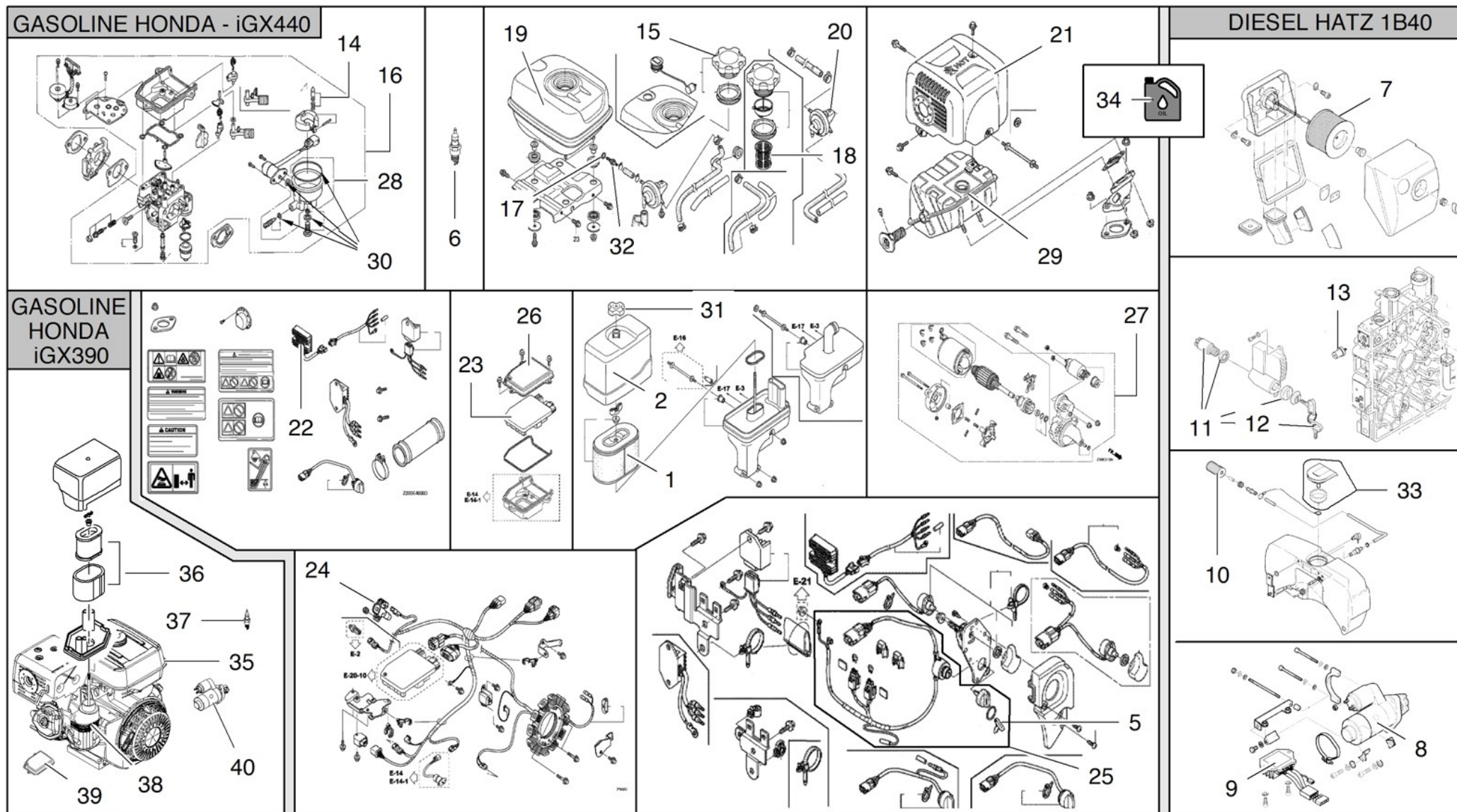

 RICAMBI MOTORE  
 ENGINE SPARE PARTS  
 PIÈCES DÉTACHÉES DU MOTEUR





MOTORERSATZTEILE   
 REPUESTOS MOTOR 









Main color codes:  J1 - JLG Cream,  J2 - JLG Orange,  C4 - Green



 RICAMBI MOTORE  
 ENGINE SPARE PARTS  
 PIÈCES DÉTACHÉES DU MOTEUR





MOTORERSATZTEILE   
 REPUESTOS MOTOR 



POS	Codice	 Descrizione	 Description	 Designation	 Benennung	 Descripción
1	2595260001	FILTRO ARIA	AIR FILTER	FILTER À AIR	LUFTFILTER	FILTRO AIRE
2	2595260002	COPERCHIO	COVER	COUVERCLE	DECKEL	TAPA
5	2595260003	CHIAVE ACCENSIONE MOTORE	KEY IGNITION ENGINE	CLÉ MOTEUR D'ALLUMAGE	ZÜNDUNGSSCHALTER ENGINE	MOTOR LLAVE
6	2595260004	CANDELA ACCENSIONE	SPARKING PLUG	BOUGIE ÉLECTRIQUE	ZÜNDKERZE	BUJÍA ENCENDIDO
7	2625560002	FILTRO ARIA	AIR FILTER	FILTER À AIR	LUFTFILTER	FILTRO AIRE
8	2631430005	MOTORINO D'AVVIAMENTO 1B40	STARTER MOTOR 1B40	MOTEUR DE DEMARREUR 1B40	STARTER MOTOR 1B40	MOTOR DE ARRANQUE 1B40
9	2558630005	REGOLATORE DI TENSIONE	VOLTAGE REGULATOR	RÉGULATEUR DE TENSION	SPANNUNGSREGLER	REGULADOR DE TENSIÓN
9	2558630005	REGOLATORE DI TENSIONE(5 WIRES VERSION)	VOLTAGE REGULATOR(5 WIRES VERSION)	RÉGULATEUR DE TENSION(5 WIRES VERSION)	SPANNUNGSREGLER(5 WIRES VERSION)	REGULADOR DE TENSIÓN(5 WIRES VERSION)
10	2558630003	FILTRO NAFTA MOTORE HATZ 1B30 E 1B40 (FINO AL SERIALE 1101917068544-1B40 E 1012917108022-1B30)	DIESEL FILTER FOR HATZ 1B30 AND 1B40 (UNTIL SERIAL 1101917068544-1B40 AND 1012917108022-1B30)	FILTRE À GASOIL	KRAFTSTOFFFILTER	FILTRO GASÓLEO
10	2558630010	FILTRO NAFTA MOTORE HATZ 1B30-1B40 ESTERNO (DA SERIALE 1101917068545-1B40 E 1012917108023-1B30)	EXTERNAL DIESEL FILTER FOR HATZ 1B30 AND 1B40 (FROM SERIAL 1101917068545-1B40 AND 1012917108023-1B30)	FILTRE NAPHTA MOTEUR HATZ 1B30-1B40 EXTERNE	FILTER NAPHTA MOTOR HATZ 1B30-1B40 EXTERNEN	FILTRO NAFTA MOTOR HATZ 1B30-1B40 ESTERNO
11	2631430001	BLOCCHETTO CHIAVE	BLOCK	BLOC	BLOCK	BLOQUE
12	2631430002	CHIAVE ACCENSIONE	IGNITION KEY	CLEF DE DÉMARRAGE	ZÜNDSCHLÜSSEL	CLAVE DE ENCENDIDO
13	2558630008	SOLENOIDE	SOLENOID	SOLENOÏDE	SOLENOID	SOLENOIDE
14	2558640008	SPIILLO	SPIILLO	AIGUILLE	NADEL	AGUJA



Main color codes:  J1 - JLG Cream,  J2 - JLG Orange,  C4 - Green



 RICAMBI MOTORE  
 ENGINE SPARE PARTS  
 PIÈCES DÉTACHÉES DU MOTEUR





MOTORERSATZTEILE   
 REPUESTOS MOTOR 



POS	Codice	 Descrizione	 Description	 Designation	 Benennung	 Descripción
15	2558640012	TAPPO SERBATOIO BENZINA	FUEL TANK CAP	BOUCHON RESERVOIR CARBURANT	TANKDECKEL	TANQUE CAP
16	2595260005	CARBURATORE PER IGX440	CARBURETOR FOR IGX440	CARBURATEUR POUR IGX440	VERGASER FÜR IGX440	CARBURADOR PARA IGX440
17	2558640031	O-RING PER FILTRO BENZINA	O-RING FOR FUEL FILTER	O-RING POUR FILTRE A CARBURANT	O-RING FÜR KRAFTSTOFF FILTER	ANILLO DE FILTRO DE COMBUSTIBLE
18	2595260006	FILTRO BENZINA SERBATOIO	FILTER FUEL TANK	RESERVOIR DE CARBURANT FILTRE	FILTER FUEL TANK	TANQUE DE COMBUSTIBLE FILTRO
19	2595260008	SERBATOIO BENZINA IGX440IU	FUEL TANK IGX440IU	RESERVOIR DE CARBURANT IGX440IU	FUEL TANK IGX440IU	TANQUE DE COMBUSTIBLE IGX440IU
20	2595260007	ASSIEME RUBINETTO AUTOMATICO CARBURANTE	AUTOMATIC FUEL VALVE ASSEMBLY	ROBINET AUTOMATIQUE	AUTOMATISCHER WASSERHAHN	GRIFO AUTOMÁTICO
21	2595260009	PROTEZIONE MARMITTA HONDA IGX440	PROTECTION MUFFLER HONDA IGX440	PROTECTION D'ECHAPPEMENT	HITZESCHUTZGITTER	PROTECCIÓN DEL SILENCIADOR
22	2595260012	REGOLATORE MOTORI HONDA IGX440	REGULATOR HONDA MOTORS IGX440	REGULATEUR	REGULATOR	REGULADOR
23	2595260013	SCHEDA CARBURATORE GX440	BOARD CARBURETOR GX440	CARTE DE CARBURANT	VERGASER KARTE	TARJETA DE COMBUSTIBLE
24	2595260024	BOBINA ACCENSIONE MOTORE IGX440	IGNITION COIL MOTOR IGX440	BOBINE D'ALLUMAGE MOTEUR IGX440	ZÜNDSPULE MOTOR IGX440	BOBINA MOTOR IGX440
25	2595260015	ASSIEME INTERUTTORI MOTORE IGX440 DA MATRICOLA MOTORE N°1002823	MOTOR ASSEMBLY SWITCHES IGX440 FROM ENGINE SERIAL N ° 1002823	COMMUTATEURS MOTEUR IGX440	SCHALTER MOTOR IGX440	INTERRUPTORES MOTOR IGX440



Main color codes:  J1 - JLG Cream,  J2 - JLG Orange,  C4 - Green





 RICAMBI MOTORE  
 ENGINE SPARE PARTS  
 PIÈCES DÉTACHÉES DU MOTEUR

MOTORERSATZTEILE   
 REPUESTOS MOTOR 

POS	Codice	 Descrizione	 Description	 Designation	 Benennung	 Descripción
26	2595260014	COPERCHIO CARBURATORE GX440	COVER CARBURETOR GX440	COVER CARBURATEUR GX440	COVER VERGASER GX440	CUBIERTA CARBURADOR GX440
27	2595260025	MOTORINO AVVIAMENTO MOTORE HONDA IGX440	STARTER MOTOR HONDA IGX440	STARTER MOTOR HONDA IGX440	STARTER MOTOR HONDA IGX440	MOTOR HONDA IGX440
28	2595260027	VASCHETTA CARBURATORE	TANK CARBURATOR	TANQUE DE COMBUSTÍVEL	FUEL TANK	TANQUE DE COMBUSTIBLE
29	2595260028	MARMITTA PER HONDA 440	SILENCER FOR HONDA 440	SILENCIEUX POUR HONDA 440	MUFFLER FÜR HONDA 440	SILENCIADOR PARA HONDA 440
30	2595260026	KIT GUARNIZIONI CARBURATORE	CARBURATOR GASKET KIT	CARBURETOR TROUSSE DE JOINT	VERGASERDICHTSAT Z KIT	CARBURADOR KIT DE JUNTAS
31	2595260029	DADO PER COPERCHIO FILTRO ARIA	NUT FOR AIR FILTER COVER	NUT POUR FILTRE A AIR COVER	NUT FOR LUFTFILTERDECKEL	TUERCA DE FILTRO DE AIRE CUBIERTA
32	2598600002	RACCORDO PER SERBATOIO	FITTING FOR TANK	MONTAGE DE RÉSERVOIR	PASSEND FÜR TANK	MONTAJE DE TANQUE
33	2631430004	TAPPO SERBATOIO GASOLIO	FUEL TANK CAP	BOUCHON RÉSERVOIR GASOIL HATZ 1B30-1B40	TANKDECKEL	TAPA DEPÓSITO GASOIL
35	2775200002	SERBATOIO BENZINA COMPLETO HONDA IGX390	FUEL TANK COMPLETE HONDA IGX390	RÉSERVOIR ESSENCE	BENZINTANK	DEPÓSITO DE GASOLINA
36	2775200001	CARTUCCIA FILTRO ARIA COMPLETA HONDA IGX390	AIR FILTER CARTRIDGE COMPLETE HONDA IGX390	FILTRE À AIR	LUFTFILTER	FILTRO DE AIRE
37	2558640003	CANDELA ACCENSIONE	SPARKING PLUG	BOUGIE ÉLECTRIQUE	ZÜNDKERZE	BUJÍA ENCENDIDO



 RICAMBI MOTORE  
 ENGINE SPARE PARTS  
 PIÈCES DÉTACHÉES DU MOTEUR



MOTORERSATZTEILE   
 REPUESTOS MOTOR 

POS	Codice	 Descrizione	 Description	 Designation	 Benennung	 Descripción
38	2775200003	CARBURATORE COMPLETO HONDA IGX390 EURO 2(VALIDO FINO A SN MOTORE 3000001)	CARBURETOR COMPLETE HONDA IGX390 EURO 2 (VALID UNTIL ENGINE SN 3000001)	CARBURATEUR COMPLET HONDA IGX390 EURO 2 (VALABLE JUSQU'AU MOTEUR SN 3000001)	VERGASER KOMPLETT HONDA IGX390 EURO 2 (GÜLTIG BIS MOTOR SN 3000001)	CARBURADOR COMPLETO HONDA IGX390 EURO 2 (VÁLIDO HASTA MOTOR SN 3000001)
38	2775200006	CARBURATORE COMPLETO HONDA IGX390 STAGE V (VALIDO DA SN MOTORE 3000001)	CARBURETOR COMPLETE HONDA IGX390 STAGE V (VALID FROM ENGINE SN 3000001)	CARBURATEUR COMPLET HONDA IGX390 STAGE V (VALABLE A PARTIR DU NUMERO DE SERIE 3000001)	VERGASER KMPL. HONDA IGX390 STAGEV (GÜLTIG AB SERIENNR. 3000001)	CARBURADOR COMPLETO HONDA IGX390 STAGE V (VÁLIDO A PARTIR DEL NÚMERO DE SERIE 3000001)
39	2775200004	CENTRALINA ELETTRONICA HONDA IGX390	ELECTRONIC CONTROL UNIT HONDA IGX390	UNITÉ ÉLECTRONIQUE	ELEKTRONISCHE EINHEIT	UNIDAD ELECTRÓNICA
40	2775200005	MOTORINO DI AVVIAMENTO COMPLETO HONDA IGX390	ELECTRIC STARTER COMPLETE HONDA IGX390	MOTEUR DE DÉMARRAGE	MOTORSTART	MOTOR DE ARRANQUE









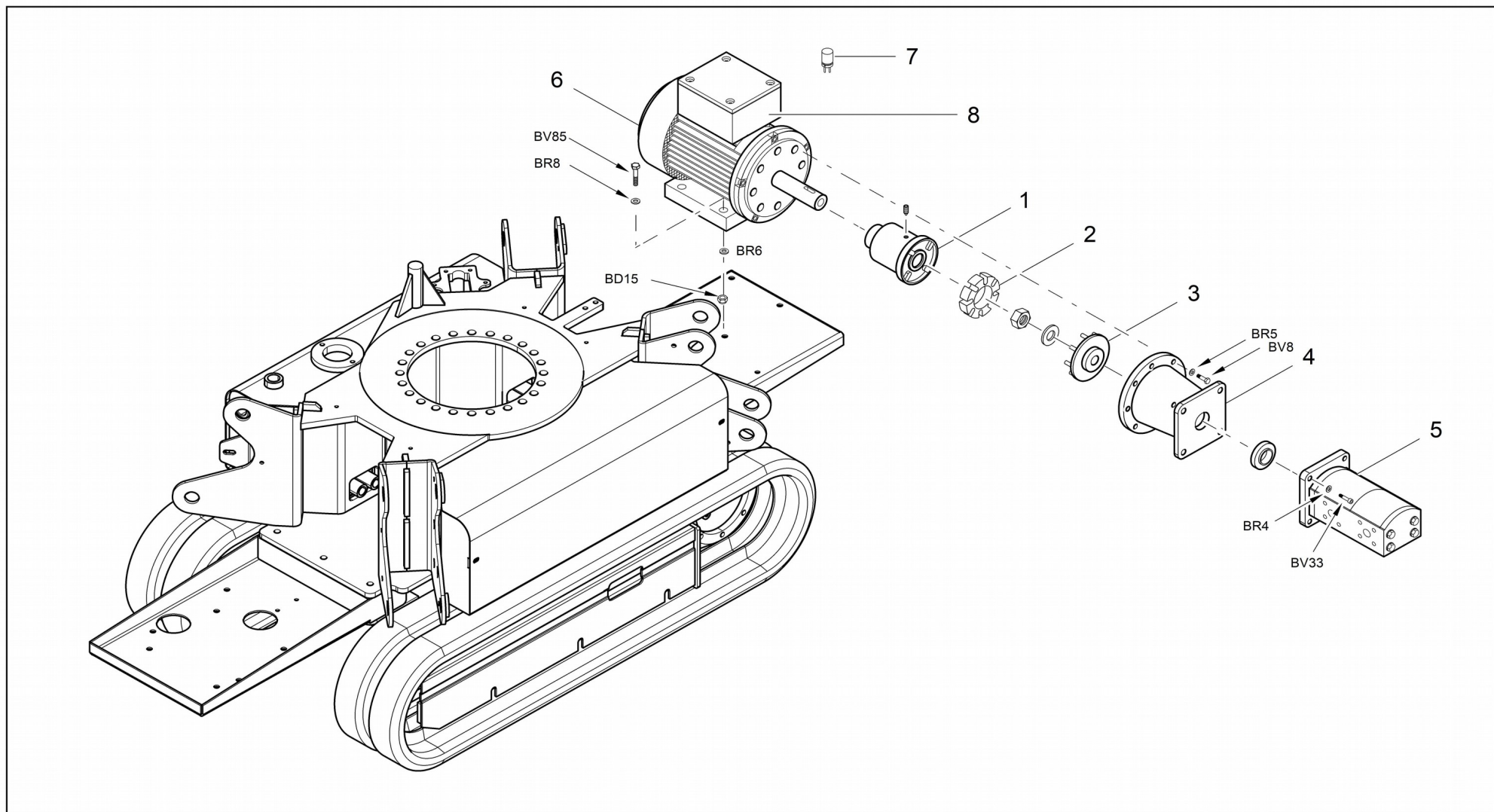



 MOTORE ELETTRICO  
 ELECTRIC MOTOR  
 MOTEUR ÉLECTRIQUE





E-MOTOR   
MOTOR ELÉCTRICO 





Main color codes:  J1 - JLG Cream,  J2 - JLG Orange,  C4 - Green





 MOTORE ELETTRICO  
 ELECTRIC MOTOR  
 MOTEUR ÉLECTRIQUE

E-MOTOR   
MOTOR ELÉCTRICO 

POS	Codice	 Descrizione	 Description	 Designation	 Benennung	 Descripción
1	05563400	SEMIGIUNTO VERSIONE MOTORE ELETTRICO STANDARD	HALF COUPLING ELECTRIC MOTOR STANDARD VERSION	DEMI-JOINT	HALBKUPPLUNG	SEMI-ACOPLAMIENTO
1	06997800	SEMIGIUNTO VERSIONE LITIO	HALF COUPLING LITHIUM VERSION	DEMI-JOINT	HALBKUPPLUNG	SEMI-ACOPLAMIENTO
2	04310100	INSERTO IN GOMMA	RUBBER INSERT	INSERT EN CAOUTCHOUC	GUMMIEINSATZ	INSERTO DE GOMA
3	04615300	GIUNTO	COUPLING	JOINT	VERBINDUNG	ACOPLAMIENTO
4	05510200	LANTERNA	LANTERN	LANTERNE	LATERNE	LINTERNA
4	07768000	LANTERNA ACCOPIAMENTO MOTORE ELETTRICO LL1775 MK2 (DA C170000893)	COUPLING ELECTRIC MOTOR LL1775 MK2 (FROM C170000893)	LANTERNE	BUCHSE	LINTERNA
5	263281H3	POMPA IDRAULICA	HYDRAULIC PUMP	POMPE HYDRAULIQUE	HYDRAULIKPUMPE	BOMBA HYDRÁULICA
6	25510100	MOTORE ELETTRICO 230V 50HZ	ELECTRIC MOTOR 230V 50HZ	MOTEUR ÉLECTRIQUE 230V 50HZ	E-MOTOR 230V 50HZ	MOTOR ELÉCTRICO 230V 50HZ
6	25576400	MOTORE ELETTRICO 110V	ELECTRIC MOTOR 110V	MOTEUR ÉLECTRIQUE 110V	E-MOTOR 110V	MOTOR ELÉCTRICO 110V
6	26219000	MOTORE ELETTRICO 230V 60HZ	ELECTRIC MOTOR 230V 60HZ	MOTEUR ÉLECTRIQUE 230V 60HZ	E-MOTOR 230V 60HZ	MOTOR ELÉCTRICO 230V 60HZ
6	26328300	MOTORE ELETTRICO 120V 60HZ 1.2KW 16A	ELECTRIC MOTOR 120V 60HZ 1.2KW 16A	MOTEUR ÉLECTRIQUE	E-MOTOR	MOTOR ELÉCTRICO
6	26774500	MOTORE ELETTRICO LITHIUM 2KW	ELECTRIC MOTOR LITHIUM 2KW	MOTEUR ÉLECTRIQUE	E-MOTOR	MOTOR ELÉCTRICO
6	27691100	MOTORE ELETTRICO 230V 50HZ MK2 (DA C170000893)	ELECTRIC MOTOR 230V 50HZ MK2 (FROM C170000893)	MOTEUR ÉLECTRIQUE 230V 50HZ MK2 (FROM C170000893)	E-MOTOR 230V 50HZ MK2 (FROM C170000893)	MOTOR ELÉCTRICO 230V 50HZ MK2 (FROM C170000893)

Main color codes:  J1 - JLG Cream,  J2 - JLG Orange,  C4 - Green

 MOTORE ELETTRICO ELECTRIC MOTOR MOTEUR ÉLECTRIQUEE-MOTOR MOTOR ELÉCTRICO 



POS	Codice	 Descrizione	 Description	 Designation	 Benennung	 Descripción
7	2557640001	CONDENSATORE 110V MF200 D=65	CAPACITOR 110V MF200 D=65	CONDENSATEUR	CAPACITOR	CAPACITOR
7	2557640002	CONDENSATORE 110V MF500	CAPACITOR 110V MF500	CONDENSATEUR	CAPACITOR	CAPACITOR
7	2632830001	CONDENSATORE PER MOTORE 120V MF120 D=55	CAPACITOR MOTOR 120V MF120 D = 55	CONDENSATEUR	KONDENSATOR	CONDENSADOR
7	2632830002	CONDENSATORE PER MOTORE 120V MF160 D=60	CAPACITOR MOTOR 120V MF160 D = 60	CONDENSATEUR	KONDENSATOR	CONDENSADOR
7	2769110001	CONDENSATORE 230V MF80 D=60 CL.B	CAPACITOR 230V MF80 D=60 CL.B	CONDENSATEUR D=60 CL.B	KONDENSATOR D=60 CL.B	CONDENSADOR D=60 CL.B
8	2769110002	SCATOLA CONDENSATORE CON GUARNIZIONE	CONDENSER BOX WITH GASKET	BOÎTE DE CONDENSEUR	KONDENSATORKAST EN	CAJA CONDENSADOR







 IMPIANTO IDRAULICO MANDATE E SCARICO

 SUPPLY AND DISCHARGE HYDRAULIC SYSTEM

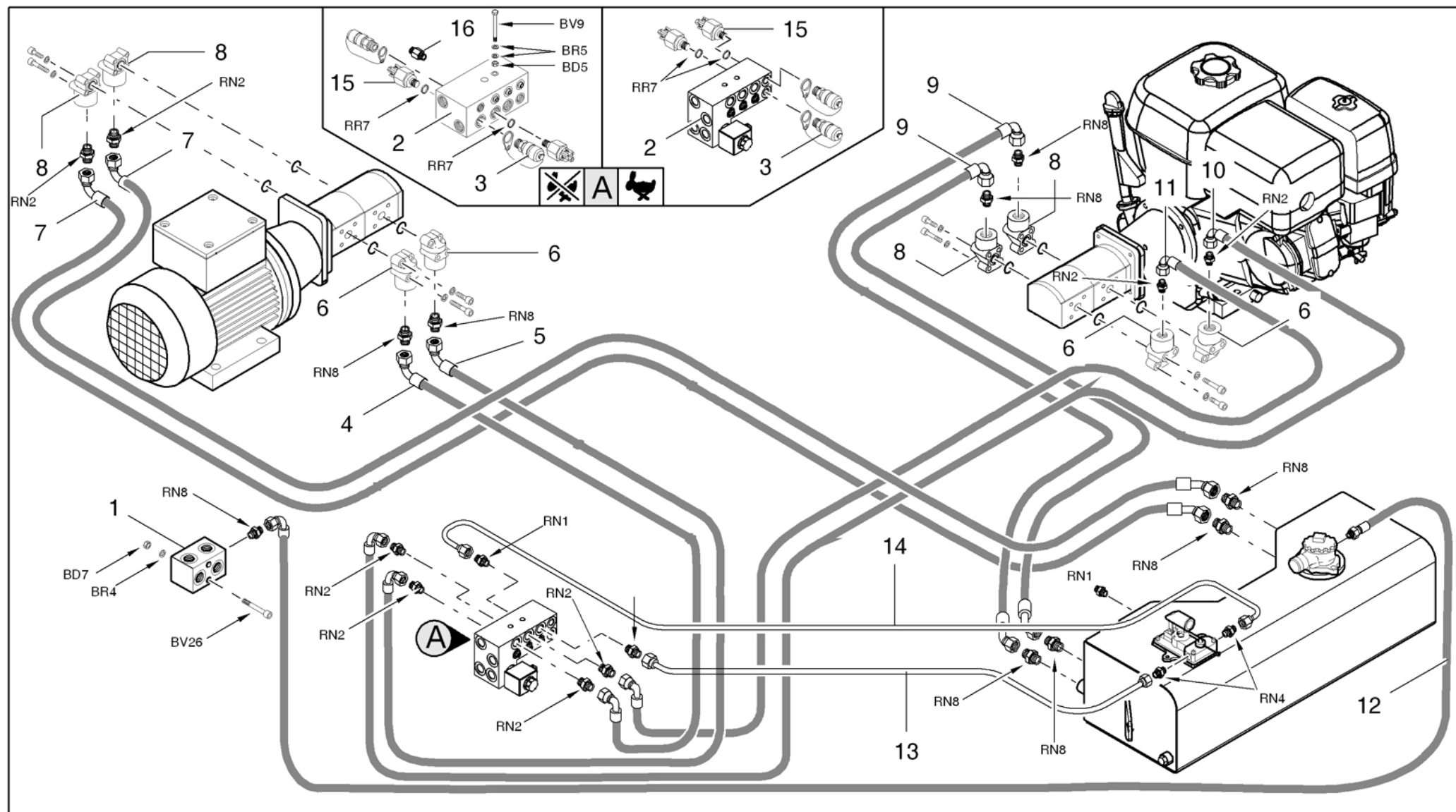
 SYSTÈME HYDRAULIQUE REFOULEMENT ET DÉCHARGEME

HYDRAULIKANLAGE VORLÄUFE UND RÜCKLAUF   
 INSTALACIÓN HIDRÁULICA IMPULSIONES Y DESCARGA 









Main color codes:  J1 - JLG Cream,  J2 - JLG Orange,  C4 - Green



 IMPIANTO IDRAULICO MANDATE E SCARICO

 SUPPLY AND DISCHARGE HYDRAULIC SYSTEM

 SYSTÈME HYDRAULIQUE REFOULEMENT ET DÉCHARGEME

 HYDRAULIKANLAGE VORLÄUFE UND RÜCKLAUF   
 INSTALACIÓN HIDRÁULICA IMPULSIONES Y DESCARGA 



POS	Codice	 Descrizione	 Description	 Designation	 Benennung	 Descripción
1	05497500	BLOCCHETTO TUBI	HOSES BLOCK	BLOC TUYAUX	ROHRBLOCK	BLOQUE TUBOS
2	16478200	VALVOLA IDRAULICA	HYDRAULIC VALVE	VALVE HYDRAULIQUE	HYDRAULIKVENTIL	VÁLVULA HIDRÁULICA
3	03014400	PROVA PRESSIONE 1/4" G	PRESSURE TEST 1/4" G	PREUVE PRESSION 1/4" G	DRUCKKONTROLLE 1/4" G	PRUEBA PRESIÓN 1/4" G
4	07165600	TUBO FLESSIBILE	FLEXIBLE PIPE	TUYAU FLEXIBLE	SCHLAUCH	TUBO FLEXIBLE
5	07165700	TUBO FLESSIBILE	FLEXIBLE PIPE	TUYAU FLEXIBLE	SCHLAUCH	TUBO FLEXIBLE
6	04048100	FLANGIA 3/8" G	FLANGE 3/8" G	BRIDE 3/8" G	FLANSCH 3/8" G	BRIDA 3/8" G
7	07164800	TUBO FLESSIBILE	FLEXIBLE PIPE	TUYAU FLEXIBLE	SCHLAUCH	TUBO FLEXIBLE
8	04845400	FLANGIA 1/2"G	FLANGE 1/2"G	BRIDE 1/2"G	FLANSCH 1/2"G	BRIDA 1/2"G
9	07164700	TUBO FLESSIBILE	FLEXIBLE PIPE	TUYAU FLEXIBLE	SCHLAUCH	TUBO FLEXIBLE
10	07165500	TUBO FLESSIBILE	FLEXIBLE PIPE	TUYAU FLEXIBLE	SCHLAUCH	TUBO FLEXIBLE
11	07165400	TUBO FLESSIBILE	FLEXIBLE PIPE	TUYAU FLEXIBLE	SCHLAUCH	TUBO FLEXIBLE
12	07164900	TUBO FLESSIBILE	FLEXIBLE PIPE	TUYAU FLEXIBLE	SCHLAUCH	TUBO FLEXIBLE
13	07152300	TUBO RIGIDO	RIGID PIPE	TUYAU RIGIDE	ROHR	TUBO RÍGIDO
14	07152400	TUBO RIGIDO	RIGID PIPE	TUYAU RIGIDE	ROHR	TUBO RÍGIDO
15	26964400	PRESSOSTATO	PRESSURE SWITCH	PRESSOSTAT	DRUCKSCHALTER	PRESÓSTATO
16	04845400	FLANGIA 1/2"G	FLANGE 1/2"G	BRIDE 1/2"G	FLANSCH 1/2"G	BRIDA 1/2"G

 Main color codes:  J1 - JLG Cream,  J2 - JLG Orange,  C4 - Green



 IMPIANTO IDRAULICO MANDATE E SCARICO

 SUPPLY AND DISCHARGE HYDRAULIC SYSTEM

 SYSTÈME HYDRAULIQUE REFOULEMENT ET DÉCHARGEMENT

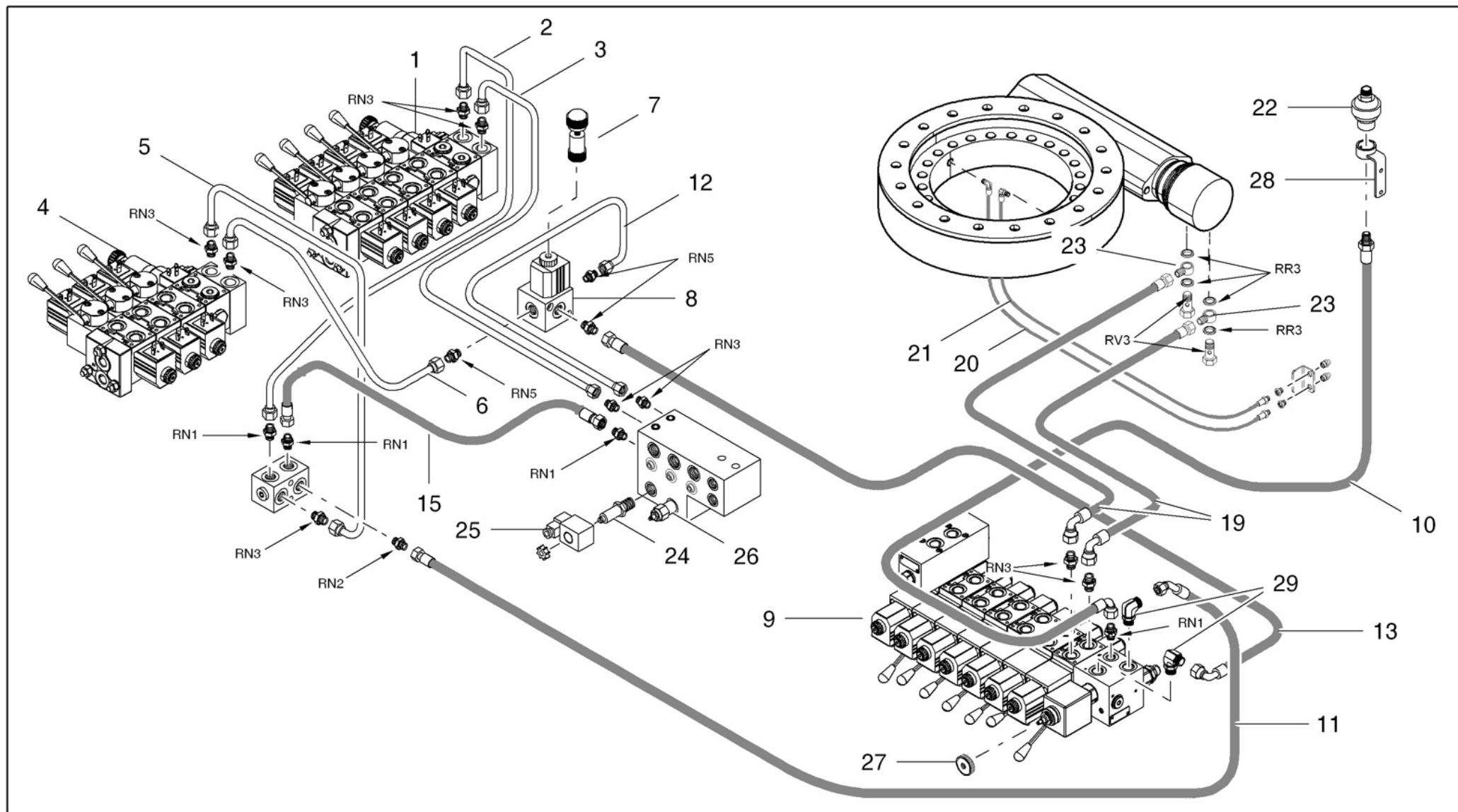
HYDRAULIKANLAGE VORLÄUFE UND RÜCKLAUF   
 INSTALACIÓN HIDRÁULICA IMPULSIONES Y DESCARGA 









Main color codes:  J1 - JLG Cream,  J2 - JLG Orange,  C4 - Green



 IMPIANTO IDRAULICO MANDATE E SCARICO

 SUPPLY AND DISCHARGE HYDRAULIC SYSTEM

 SYSTÈME HYDRAULIQUE REFOULEMENT ET DÉCHARGEMENT

 HYDRAULIKANLAGE VORLÄUFE UND RÜCKLAUF   
 INSTALACIÓN HIDRÁULICA IMPULSIONES Y DESCARGA 

POS	Codice	 Descrizione	 Description	 Designation	 Benennung	 Descripción
1	27299100	DISTRIBUTORE LC STABILIZZATORI- TRAINO 4 ELEMENTI CON LEVE EMERGENZA A PULSANTE	HYDRAULIC DISTRIBUTOR STABILIZERS-TRACKS 4 PARTS WITH LEVERS EMERGENCY BUTTON	DISTRIBUTEUR HYDRAULIQUE	HYDRAULIKVENTILB LOCK	DISTRIBUIDOR HIDRÁULICO
2	07168300	TUBO RIGIDO	RIGID PIPE	TUYAU RIGIDE	ROHR	TUBO RÍGIDO
3	07151800	TUBO RIGIDO	RIGID PIPE	TUYAU RIGIDE	ROHR	TUBO RÍGIDO
4	27299000	DISTRIBUTORE LC STABILIZZATORI- TRAINO 3 ELEMENTI CON LEVE EMERGENZA A PULSANTE	HYDRAULIC DISTRIBUTOR STABILIZERS-TRACKS 3 PARTS WITH LEVERS EMERGENCY BUTTON	DISTRIBUTEUR HYDRAULIQUE	HYDR. REGELSTEUERGERÄT	DISTRIBUIDOR HIDRÁULICO
5	07151500	TUBO RIGIDO	RIGID PIPE	TUYAU RIGIDE	ROHR	TUBO RÍGIDO
6	07151700	TUBO RIGIDO	RIGID PIPE	TUYAU RIGIDE	ROHR	TUBO RÍGIDO
7	25908400	DISPOSITIVO DI COMANDO MANUALE IDRAULICO	HAND CONTROL HYDRAULIC	COMMANDE HYDRAULIQUE	HYDRAULISCHER ANTRIEB	COMANDO HIDRÁULICO
7	28140600	DISPOSITIVO DI COMANDO MANUALE IDRAULICO NEW SOLENOID CONCEPT	HAND CONTROL HYDRAULIC NEW SOLENOID CONCEPT	COMMANDE HYDRAULIQUE	HYDRAULISCHER ANTRIEB	COMANDO HIDRÁULICO
8	25732900	DEVIATORE IDRAULICO	HYDRAULIC DIVERTER	DÈVIATEUR	WECHSELSCHLTER	DESVIADOR
9	27323500	DISTRIBUTORE IDRAULICO 7 ELEMENTI PARTE AEREA CON PULSANTE	HYDRAULIC DISTRIBUTOR 7 ELEMENTS AERIAL PART WITH BUTTON	DISTRIBUTEUR HYDRAULIQUE	HYDRAULISCHER VERTEILER	DISTRIBUIDOR HIDRÁULICO





 Main color codes:  J1 - JLG Cream,  J2 - JLG Orange,  C4 - Green





 IMPIANTO IDRAULICO MANDATE E SCARICO

 SUPPLY AND DISCHARGE HYDRAULIC SYSTEM

 SYSTÈME HYDRAULIQUE REFOULEMENT ET DÉCHARGEMENT
HYDRAULIKANLAGE VORLÄUFE UND RÜCKLAUF INSTALACIÓN HIDRÁULICA IMPULSIONES Y DESCARGA 



POS	Codice	 Descrizione	 Description	 Designation	 Benennung	 Descripción
9	27533400	DISTRIBUTORE IDRAULICO 7 ELEMENTI PARTE AEREA CON PULSANTE (FOR LL1775-X17JP-X500AJ-LL2010-X20JP-X600AJ MK2 FROM C170000893)	HYDRAULIC DISTRIBUTOR 7 ELEMENTS AERIAL PART WITH BUTTON (FOR LL1775-X17JP-X500AJ-LL2010-X20JP-X600AJ MK2 FROM C170000893)	DISTRIBUTEUR HYDRAULIQUE (FOR LL1775-X17JP-X500AJ-LL2010-X20JP-X600AJ MK2 FROM C170000893)	HYDRAULISCHER VERTEILER (FOR LL1775-X17JP-X500AJ-LL2010-X20JP-X600AJ MK2 FROM C170000893)	DISTRIBUIDOR HIDRÁULICO (FOR LL1775-X17JP-X500AJ-LL2010-X20JP-X600AJ MK2 FROM C170000893)
10	07166500	TUBO FLESSIBILE	FLEXIBLE PIPE	TUYAU FLEXIBLE	SCHLAUCH	TUBO FLEXIBLE
11	07166700	TUBO FLESSIBILE	FLEXIBLE PIPE	TUYAU FLEXIBLE	SCHLAUCH	TUBO FLEXIBLE
11	07723700	TUBO FLESSIBILE (MK2 FROM C170000893)	FLEXIBLE PIPE (MK2 FROM C170000893)	TUYAU FLEXIBLE (MK2 FROM C170000893)	SCHLAUCH (MK2 FROM C170000893)	TUBO FLEXIBLE (MK2 FROM C170000893)
12	07151900	TUBO RIGIDO	RIGID PIPE	TUYAU RIGIDE	ROHR	TUBO RÍGIDO
13	07166800	TUBO FLESSIBILE	FLEXIBLE PIPE	TUYAU FLEXIBLE	SCHLAUCH	TUBO FLEXIBLE
13	07723800	TUBO FLESSIBILE (MK2 FROM C170000893)	FLEXIBLE PIPE (MK2 FROM C170000893)	TUYAU FLEXIBLE (MK2 FROM C170000893)	SCHLAUCH (MK2 FROM C170000893)	TUBO FLEXIBLE (MK2 FROM C170000893)
15	07225500	TUBO FLESSIBILE	FLEXIBLE PIPE	TUYAU FLEXIBLE	SCHLAUCH	TUBO FLEXIBLE
15	07738700	TUBO FLESSIBILE	FLEXIBLE PIPE	TUYAU FLEXIBLE	SCHLAUCH	TUBO FLEXIBLE
19	07166600	TUBO FLESSIBILE	FLEXIBLE PIPE	TUYAU FLEXIBLE	SCHLAUCH	TUBO FLEXIBLE
19	07723600	TUBO FLESSIBILE (MK2 FROM C170000893)	FLEXIBLE PIPE (MK2 FROM C170000893)	TUYAU FLEXIBLE (MK2 FROM C170000893)	SCHLAUCH (MK2 FROM C170000893)	TUBO FLEXIBLE (MK2 FROM C170000893)
20	07165800	TUBO FLESSIBILE	FLEXIBLE PIPE	TUYAU FLEXIBLE	SCHLAUCH	TUBO FLEXIBLE
21	07165900	TUBO FLESSIBILE	FLEXIBLE PIPE	TUYAU FLEXIBLE	SCHLAUCH	TUBO FLEXIBLE
22	26062200	ACCUMULATORE	ACCUMULATOR	ACCUMULTEUR	AKKUMULATOR	ACUMULADOR
23	05725900	RACCORDO SPECIALE PER MOTORE DI ROTAZIONE (GL E VERSIONE LITHIUM)	SPECIAL FITTING FOR MOTOR ROTATION (GL VERSION AND LITHIUM)	RACCORD	ANSCHLUSS	CONEXIÓN
23	07057000	RACCORDO	FITTING	RACCORD	ANSCHLUSS	CONEXIÓN
24	1647820003	ELETTROVALVOLA	SOLENOID VALVE	ÉLECTROVANNE	MAGNETVENTIL	ELECTROVÁLVULA





Main color codes:  J1 - JLG Cream,  J2 - JLG Orange,  C4 - Green



 IMPIANTO IDRAULICO MANDATE E SCARICO

 SUPPLY AND DISCHARGE HYDRAULIC SYSTEM

 SYSTÈME HYDRAULIQUE REFOULEMENT ET DÉCHARGEMENT



HYDRAULIKANLAGE VORLÄUFE UND RÜCKLAUF   
INSTALACIÓN HIDRÁULICA IMPULSIONES Y DESCARGA 



POS	Codice	 Descrizione	 Description	 Designation	 Benennung	 Descripción
26	1647820001	VALVOLA IDRAULICA	HYDRAULIC VALVE	VALVE HYDRAULIQUE	HYDRAULIKVENTIL	VÁLVULA HIDRÁULICA
28	36470800	SUPPORTO	SUPPORT	SUPPORT	HALTERUNG	SOPORTE
29	04995000	RACCORDO	FITTING	RACCORD	ANSCHLUSS	CONEXIÓN

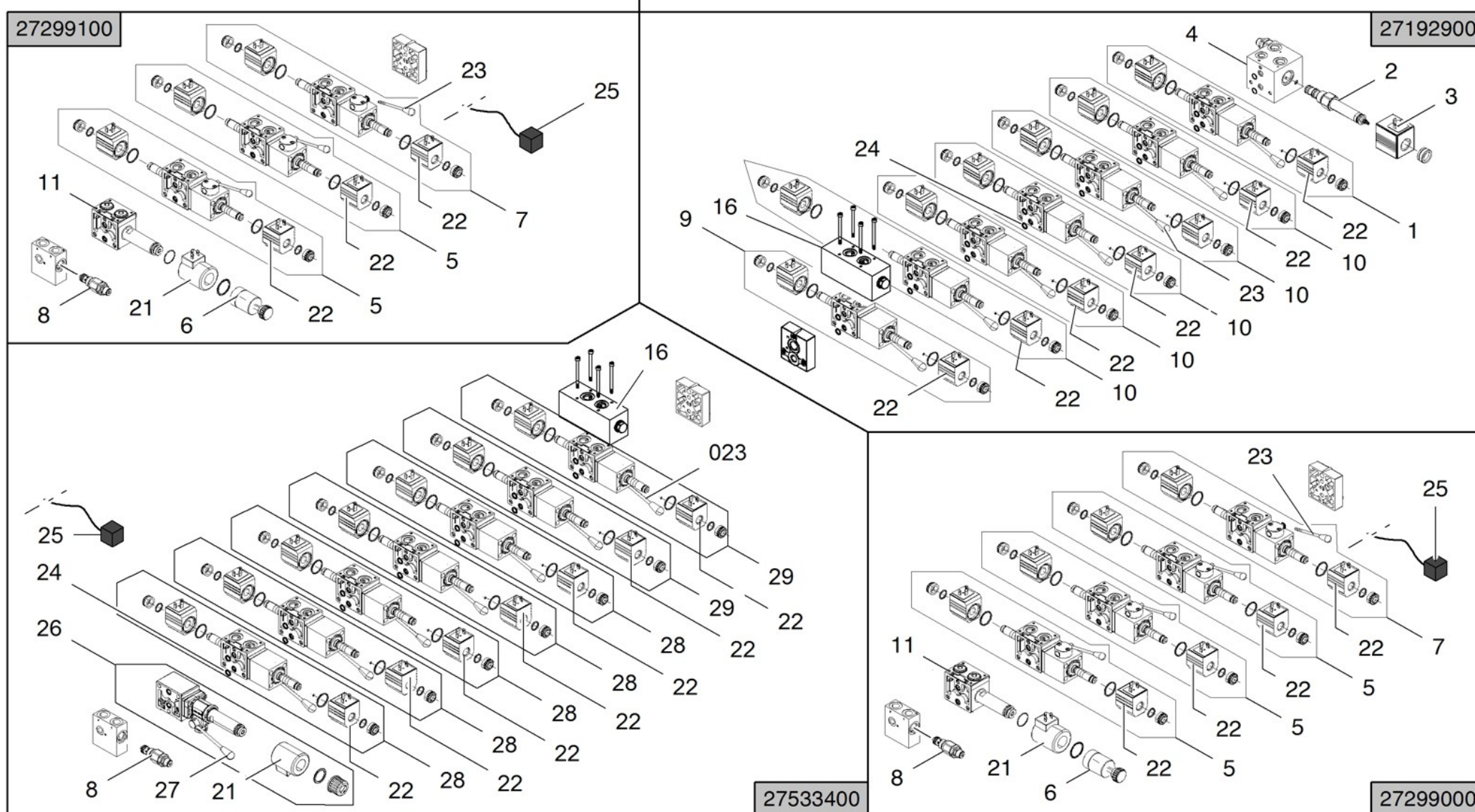



 DISTRIBITORI IDRAULICI  
 HYDRAULIC DISTRIBUTORS  
 DISTRIBUTEURS HYDRAULIQUES



HYDRAULISCHE REGELSTEUERGERÄTE   
 DISTRIBUIDORES HIDRÁULICOS 



 DISTRIBUTORI IDRAULICI  
 HYDRAULIC DISTRIBUTORS  
 DISTRIBUTEURS HYDRAULIQUES

HYDRAULISCHE REGELSTEUERGERÄTE   
 DISTRIBUIDORES HIDRÁULICOS 





POS	Codice	 Descrizione	 Description	 Designation	 Benennung	 Descripción
1	2666800007	SEZIONE DISTRIBUTORE ROTAZIONE AEREA AB CHIUSO	CONTROL VALVE SECTION AERIAL ROTATION AB CLOSED	CORPS	GEHÄUSE	CUERPO
2	07325200	VALVOLA PROPORZIONALE (CARTUCCIA) PARTE AEREA PIATTAFORME CON RITORNO A MOLLA COMPLETA DI PULSANTE	PROPORTIONAL VALVE AERIAL PARTS WITH SPRING RETURN COMPLETE BUTTON	SOUPAPE PROPORTIONELLE	PROPORTIONALVENT IL	VALVULA PROPORCIONAL
3	06037900	BOBINA PER VALVOLA PROPORZIONALE PARTE AEREA	COIL PROPORTIONAL VALVE FOR AERIAL PART	BOBINE	SPULE	BOBINA
4	2719290001	SEZIONE DISTRIBUTORE SOLO CORPO METALLICO	CONTROL VALVE SECTION ONLY METAL BODY	CORPS	GEHÄUSE	CUERPO
5	2645900005	SEZIONE DISTRIBUTORE AB CHIUSO CON LEVA (LATO A) E BOBINA	VALVE BLOCK SECTION AB CLOSED WITH LEVER (SIDE A) AND COIL	SECTION DISTRIBUTEUR	VENTILBLOCKSEKTIO N	SECCIÓN DISTRIBUIDOR
6	07324900	COMANDO MANUALE EMERGENZA CON RITORNO A MOLLA	EMERGENCY MAUAL CONTROL WITH SPRING RETURN	COMMANDE MANUEL D'URGENCE	MANUELLES ANTRIEB FÜR NOTSTAND	MANDO MANUAL DE EMERGENCIA
7	2645900006	SEZIONE DISTRIBUTORE ABT CON LEVA (LATO A) E BOBINA	VALVE BLOCK SECTION ABT WITH LEVER (SIDE A) AND COIL	SECTION DISTRIBUTEUR	VENTILBLOCKSEKTIO N	SECCIÓN DISTRIBUIDOR
8	2645900002	CARTUCCIA VALVOLA DI MASSIMA PRESSIONE	CARTRIDGE PRESSURE RELIEF VALVE	CARTOUCHE SOUPAPE DE SÉCURITÉ	PARTONE ÜBERDRUCKVENTIL	CATUCHO VÁLVULA LIMITADORA DE PRESIÓN



Main color codes:  J1 - JLG Cream,  J2 - JLG Orange,  C4 - Green



 DISTRIBUTORI IDRAULICI



 HYDRAULIC DISTRIBUTORS





 DISTRIBUTEURS HYDRAULIQUES
HYDRAULISCHE REGELSTEUERGERÄTE DISTRIBUIDORES HIDRÁULICOS 



POS	Codice	 Descrizione	 Description	 Designation	 Benennung	 Descripción
9	2666800006	SEZIONE DISTRIBUTORE ABT CON LEVA (LATO B 180°) E BOBINA	SECTION DISTRIBUTOR ABT WITH LEVER (SIDE B 180°) AND COIL	CORPS	GEHÄUSE	CUERPO
10	2666800005	SEZIONE DISTRIBUTORE AB CHIUSO CON LEVA (LATO B 180°) E BOBINA	SECTION DISTRIBUTOR AB CHIUSO WITH LEVER (SIDE B 180°) AND COIL	CORPS	GEHÄUSE	CUERPO
11	2729900001	VALVOLA PROPORZIONALE TRAINI CON BOBINA E SENZA COMANDO MANUALE A MOLLA	PROPORTIONAL VALVE FOR TRACK WITH COIL AND WITHOUT MANUAL SPRING	SOUPAPE PROPORTIONELLE	PROPORTIONALVENT IL	VÁLVULA PROPORCIONAL
16	2585560004	BLOCCO VALVOLA BILANCIAMENTO BRACCI SU DISTRIBUTORI PARTE AEREA	BALANCING VALVE BLOCK BOOMS OF DISTRIBUTORS AERIAL PART	BLOC SOUPAPE	VENTILSPERRE	BLOQUE VÁLVULA
21	06037100	BOBINA PER VALVOLA PROPORZIONALE PARTE CARRO	COIL PROPORTIONAL VALVE FOR UNDERCARRIAGE	BOBINE	SPULE	BOBINA
22	05913800	BOBINA PER ON-OFF	COIL FOR ON-OFF	BOBINE	SPULE	BOBINA
23	07300200	LEVA DISTRIBUTORE	LEVER HYDRAULIC DISTRIBUTOR	LEVIER	HEBEL	PALANCA
24	2585560005	O-RING	O-RING	O-RING	O-RING	O-RING
25	1730720001	ELETTROVALVOLA ON-OFF CON LED	SOLENOID ON-OFF WITH LED	ELECTROVANNE ON- OFF AVEC LED	SOLENOID ON-OFF WITH LED	SOLENOIDE ON-OFF CON LED

Main color codes:  J1 - JLG Cream,  J2 - JLG Orange,  C4 - Green



 DISTRIBUTORI IDRAULICI  
 HYDRAULIC DISTRIBUTORS  
 DISTRIBUTEURS HYDRAULIQUES

HYDRAULISCHE REGELSTEUERGERÄTE   
DISTRIBUIDORES HIDRÁULICOS 



POS	Codice	 Descrizione	 Description	 Designation	 Benennung	 Descripción
26	2753340004	ELEMENTO DISTRIBUTORE COMPLETO DI PROPORZIONALE PARTE AEREA CON LEVA ROSSA (LATO 1)	VALVE BLOCK ELEMENT	ELEMENT DISTRIBUTEUR	VENTILBLOCKSATZ	ELEMENTO DISTRIBUIDOR
27	2753340003	LEVA ROSSA DISTRIBUTORE	RED LEVER HYDRAULIC DISTRIBUTOR	LEVIER	HEBEL	PALANCA
28	2753340001	SEZIONE DISTRIBUTORE AB CHIUSO CON LEVA (LATO 1) E BOBINA	SECTION DISTRIBUTOR AB CLOSED WITH LEVER (SIDE 1) AND COIL	SECTION DISTRIBUTEUR	VENTILBLOCKSEKTIO N	SECCIÓN DISTRIBUIDOR
29	2753340002	SEZIONE DISTRIBUTORE ABT CON LEVA (LATO 1) E BOBINA	SECTION DISTRIBUTOR ABT WITH LEVER (SIDE 1) AND COIL	SECTION DISTRIBUTEUR	VENTILBLOCKSEKTIO N	SECCIÓN DISTRIBUIDOR

Main color codes:  J1 - JLG Cream,  J2 - JLG Orange,  C4 - Green

- IMPIANTO IDRAULICO TRAZIONE
- HYDRAULIC SYSTEM FOR TRACTION
- SYSTÈME HYDRAULIQUE DE TRACTION

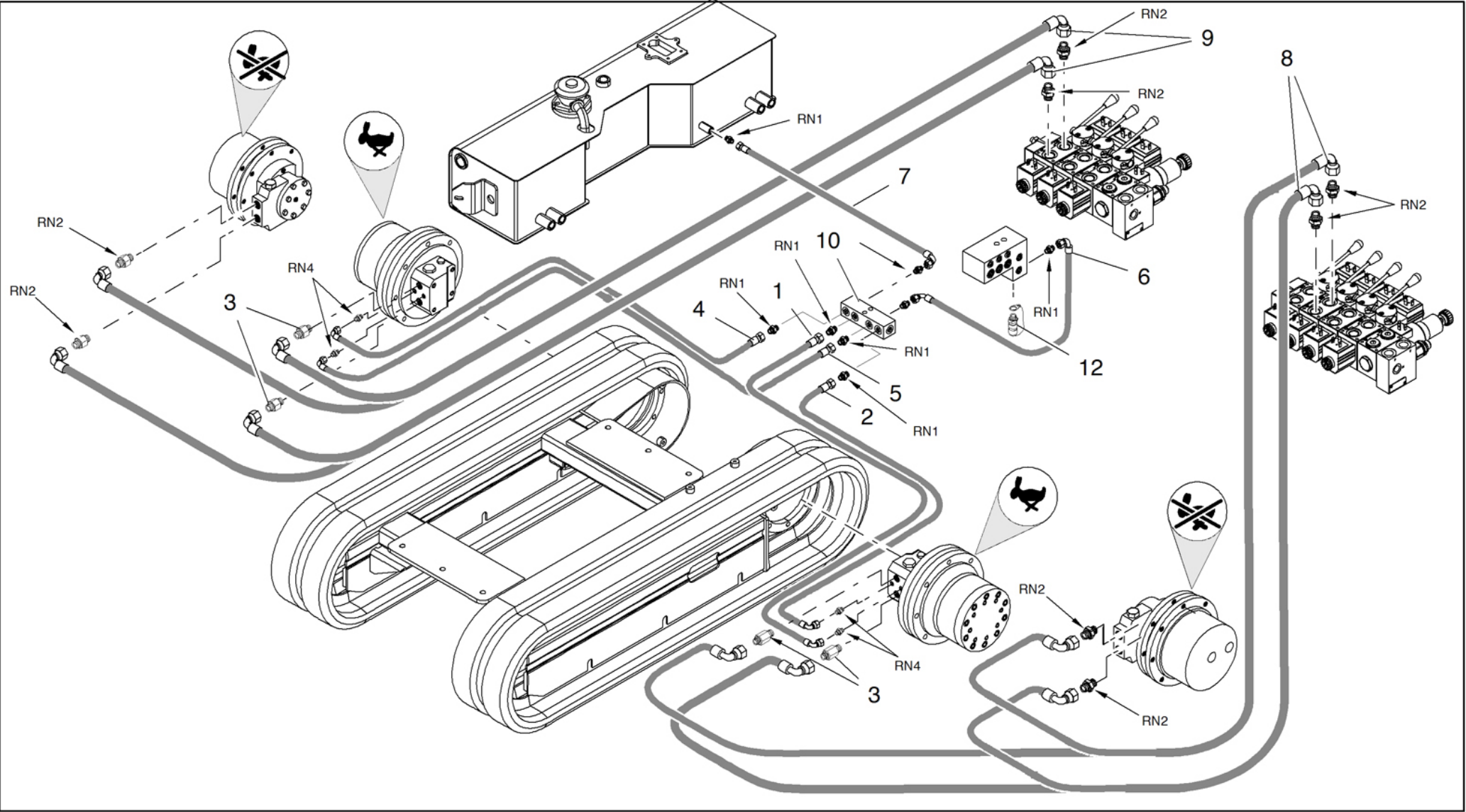
HYDRAULIKANLAGE ANTRIEB   
 INSTALACIÓN HIDRÁULICA TRACCIÓN 







Main color codes:  **J1** - JLG Cream,  **J2** - JLG Orange,  **C4** - Green



 IMPIANTO IDRAULICO TRAZIONE



 HYDRAULIC SYSTEM FOR TRACTION

 SYSTÈME HYDRAULIQUE DE TRACTION
HYDRAULIKANLAGE ANTRIEB INSTALACIÓN HIDRÁULICA TRACCIÓN 



POS	Codice	 Descrizione	 Description	 Designation	 Benennung	 Descripción
1	07163400	TUBO FLESSIBILE	FLEXIBLE PIPE	TUYAU FLEXIBLE	SCHLAUCH	TUBO FLEXIBLE
2	07163200	TUBO FLESSIBILE	FLEXIBLE PIPE	TUYAU FLEXIBLE	SCHLAUCH	TUBO FLEXIBLE
3	05093900	RACCORDO 12L-3/8 JIS ESAGONO 22 H40	12L-FITTING 3/8 JIS HEX22 H40	RACCORD	ANSCHLUSS	CONEXIÓN
4	07163500	TUBO FLESSIBILE	FLEXIBLE PIPE	TUYAU FLEXIBLE	SCHLAUCH	TUBO FLEXIBLE
5	07163300	TUBO FLESSIBILE	FLEXIBLE PIPE	TUYAU FLEXIBLE	SCHLAUCH	TUBO FLEXIBLE
6	07167900	TUBO RIGIDO	RIGID PIPE	TUYAU RIGIDE	ROHR	TUBO RÍGIDO
7	07164200	TUBO FLESSIBILE	FLEXIBLE PIPE	TUYAU FLEXIBLE	SCHLAUCH	TUBO FLEXIBLE
8	07163600	TUBO FLESSIBILE	FLEXIBLE PIPE	TUYAU FLEXIBLE	SCHLAUCH	TUBO FLEXIBLE
9	07163700	TUBO FLESSIBILE	FLEXIBLE PIPE	TUYAU FLEXIBLE	SCHLAUCH	TUBO FLEXIBLE
10	04707700	COLLETTORE	MANIFOLD	COLLECTEUR	KOLLEKTOR	COLECTOR
11	05582000	RACCORDO	FITTING	RACCORD	ANSCHLUSS	CONEXIÓN
12	05242300	PRESA PRESSIONE 1/8" G	PRESSURE SOCKET 1/8" G	PRISE PRESSION 1/8" G	STECKDOSE KONTROLLE 1/8" G	TOMA PRESIÓN 1/8" G





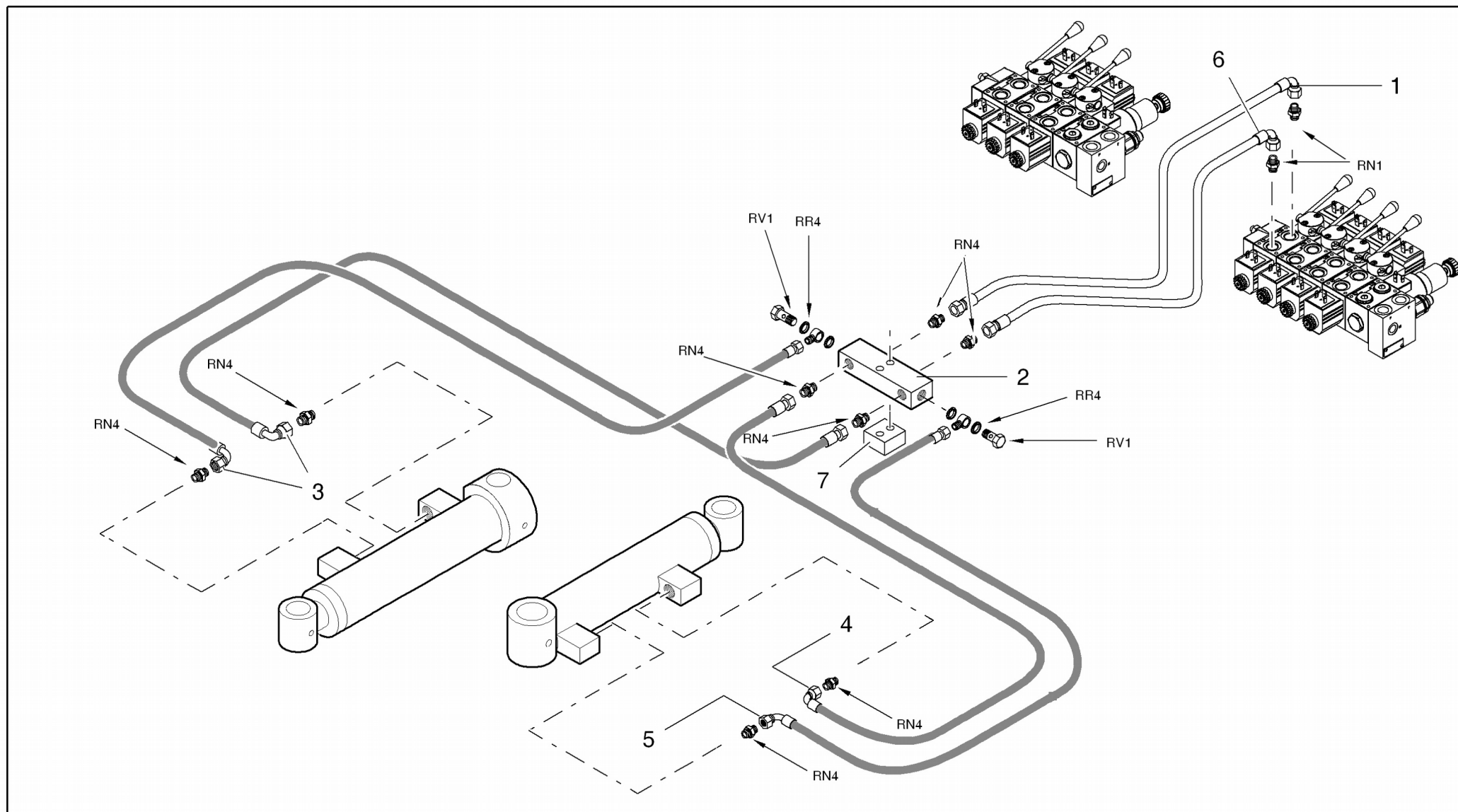

 IMPIANTO IDRAULICO ALLARGAMENTO CARRO  
 HYDRAULIC SYSTEM UNDERCARRIAGE EXPANSION  
 SYSTÈME HYDRAULIQUE EXTENSION DU CHARIOT





HYDRAULIKANLAGE VERBREITERUNG WAGEN   
 INSTALACIÓN HIDRAULICA ENSANCHAMIENTO CARRO 







Main color codes:  J1 - JLG Cream,  J2 - JLG Orange,  C4 - Green

 IMPIANTO IDRAULICO ALLARGAMENTO CARRO  
 HYDRAULIC SYSTEM UNDERCARRIAGE EXPANSION  
 SYSTÈME HYDRAULIQUE EXTENSION DU CHARIOT



HYDRAULIKANLAGE VERBREITERUNG WAGEN   
 INSTALACIÓN HIDRAULICA ENSANCHAMIENTO CARRO 

POS	Codice	 Descrizione	 Description	 Designation	 Benennung	 Descripción
1	07168100	TUBO RIGIDO	RIGID PIPE	TUYAU RIGIDE	ROHR	TUBO RÍGIDO
3	07163800	TUBO FLESSIBILE	FLEXIBLE PIPE	TUYAU FLEXIBLE	SCHLAUCH	TUBO FLEXIBLE
4	07164000	TUBO FLESSIBILE	FLEXIBLE PIPE	TUYAU FLEXIBLE	SCHLAUCH	TUBO FLEXIBLE
5	07164100	TUBO FLESSIBILE	FLEXIBLE PIPE	TUYAU FLEXIBLE	SCHLAUCH	TUBO FLEXIBLE
6	07168200	TUBO RIGIDO	RIGID PIPE	TUYAU RIGIDE	ROHR	TUBO RÍGIDO



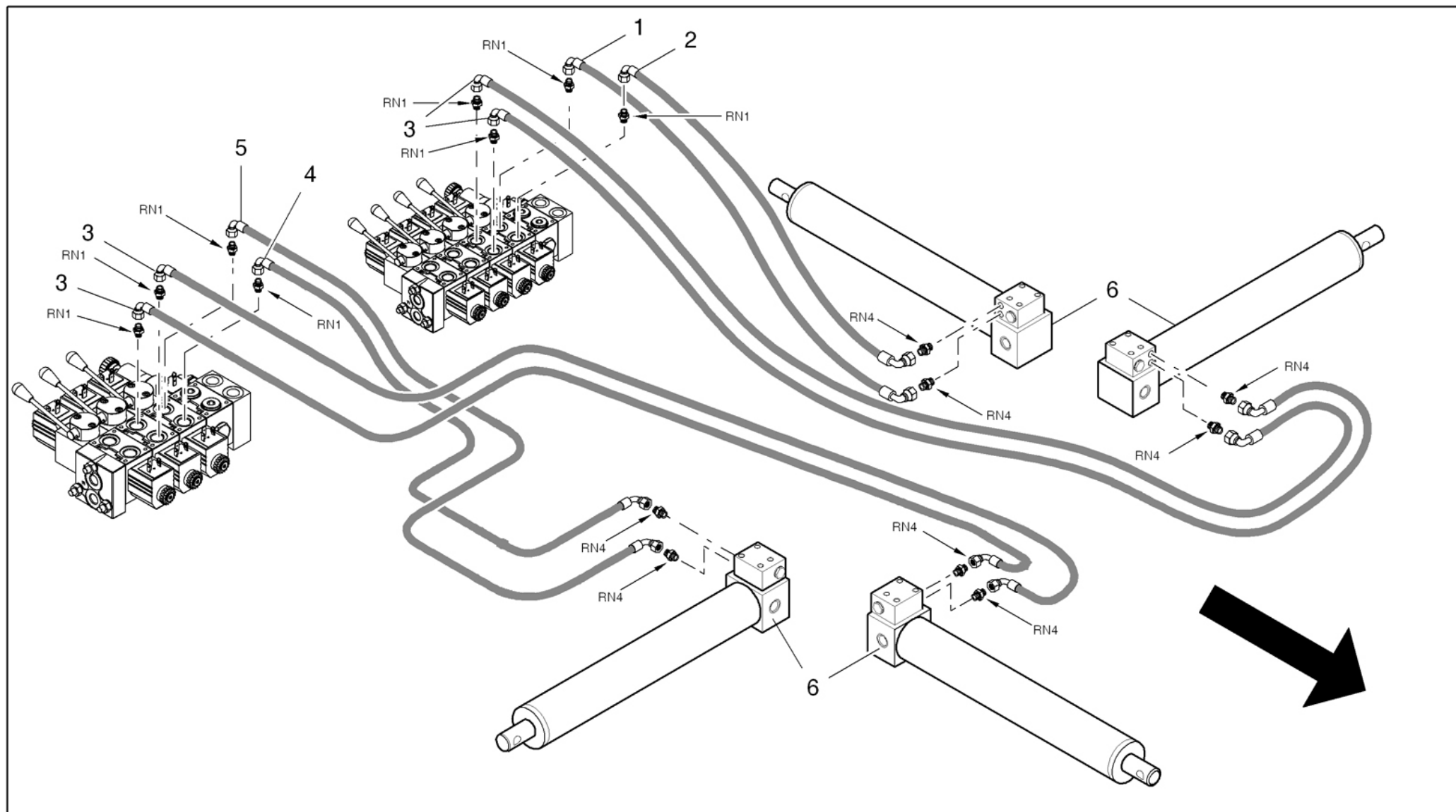

-  IMPIANTO IDRAULICO STABILIZZATORI
-  STABILIZERS HYDRAULIC SYSTEM
-  INSTALLATION HYDRAULIQUE STABILISATERS



-  ABSTÜTZUNG ABSTÜTZUNGSHYDRAULIKZYLIND
-  INSTALACIÓN HIDRAULICA ESTABILIZADORS



Main color codes:  J1 - JLG Cream,  J2 - JLG Orange,  C4 - Green

 IMPIANTO IDRAULICO STABILIZZATORI STABILIZERS HYDRAULIC SYSTEM INSTALLATION HYDRAULIQUE STABILISATERSABSTÜTZUNG ABSTÜTZUNGSHYDRAULIKZYLIND INSTALACIÓN HIDRAULICA ESTABILIZADORS 

POS	Codice	 Descrizione	 Description	 Designation	 Benennung	 Descripción
1	07164600	TUBO FLESSIBILE	FLEXIBLE PIPE	TUYAU FLEXIBLE	SCHLAUCH	TUBO FLEXIBLE
2	07164500	TUBO FLESSIBILE	FLEXIBLE PIPE	TUYAU FLEXIBLE	SCHLAUCH	TUBO FLEXIBLE
3	07165200	TUBO FLESSIBILE	FLEXIBLE PIPE	TUYAU FLEXIBLE	SCHLAUCH	TUBO FLEXIBLE
4	07164300	TUBO FLESSIBILE	FLEXIBLE PIPE	TUYAU FLEXIBLE	SCHLAUCH	TUBO FLEXIBLE
5	07164400	TUBO FLESSIBILE	FLEXIBLE PIPE	TUYAU FLEXIBLE	SCHLAUCH	TUBO FLEXIBLE
6	270554H2	CILINDRO	CYLINDER	CYLINDER	ZYLINDER	CILINDRO



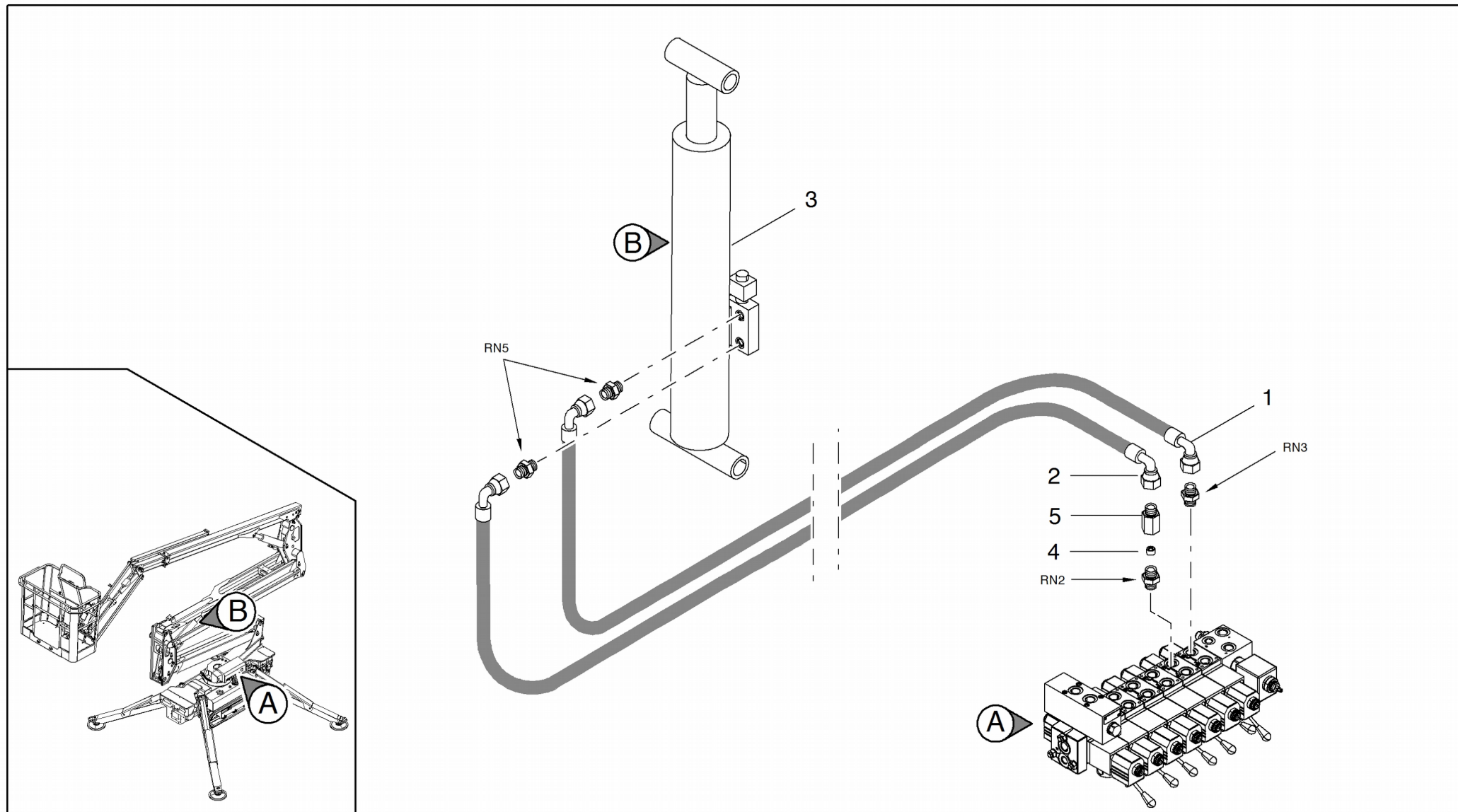

Main color codes:  J1 - JLG Cream,  J2 - JLG Orange,  C4 - Green







 IMPIANTO IDRAULICO 1-2 BRACCI

 1-2 ARMS HYDRAULIC SYSTEM



 SYSTÈME HYDRAULIQUE 1-2 BRAS
HYDRAULIKANLAGE 1-2 ARM INSTALACIÓN HIDRÁULICA 1-2 BRAZOS 

POS	Codice	 Descrizione	 Description	 Designation	 Benennung	 Descripción
1	07166000	TUBO FLESSIBILE	FLEXIBLE PIPE	TUYAU FLEXIBLE	SCHLAUCH	TUBO FLEXIBLE
1	07723900	TUBO FLESSIBILE (MK2 FROM C170000893)	FLEXIBLE PIPE (MK2 FROM C170000893)	TUYAU FLEXIBLE (MK2 FROM C170000893)	SCHLAUCH (MK2 FROM C170000893)	TUBO FLEXIBLE (MK2 FROM C170000893)
2	07166100	TUBO FLESSIBILE	FLEXIBLE PIPE	TUYAU FLEXIBLE	SCHLAUCH	TUBO FLEXIBLE
2	07724000	TUBO FLESSIBILE (MK2 FROM C170000893)	FLEXIBLE PIPE (MK2 FROM C170000893)	TUYAU FLEXIBLE (MK2 FROM C170000893)	SCHLAUCH (MK2 FROM C170000893)	TUBO FLEXIBLE (MK2 FROM C170000893)
3	27069100	CILINDRO PRIMO BRACCIO	FIRST ARM CYLINDER	CYLINDRE SECT.TÉLESCOP.	TELESKOPZYLINDER	CIL. BRAZO TELESCÓP.
3	270691H2	CILINDRO PRIMO BRACCIO	FIRST ARM CYLINDER	CYLINDRE SECT.TÉLESCOP.	TELESKOPZYLINDER	CIL. BRAZO TELESCÓP.
4	07688500	PASTIGLIA VNR STROZZATA 3/8 FORO DA Ø=2MM	VALVE	SOUPAPE	VENTIL	VALVULA
5	07688400	RACCORDO PROLUNGA M-F 3/8 H=30 FILETTO UTILE 25	FITTING	RACCORD	ANSCHLUSS	CONEXIÓN

 IMPIANTO IDRAULICO 3 BRACCIO  
 3 ARM HYDRAULIC SYSTEM  
 SYSTÈME HYDRAULIQUE 3 BRAS

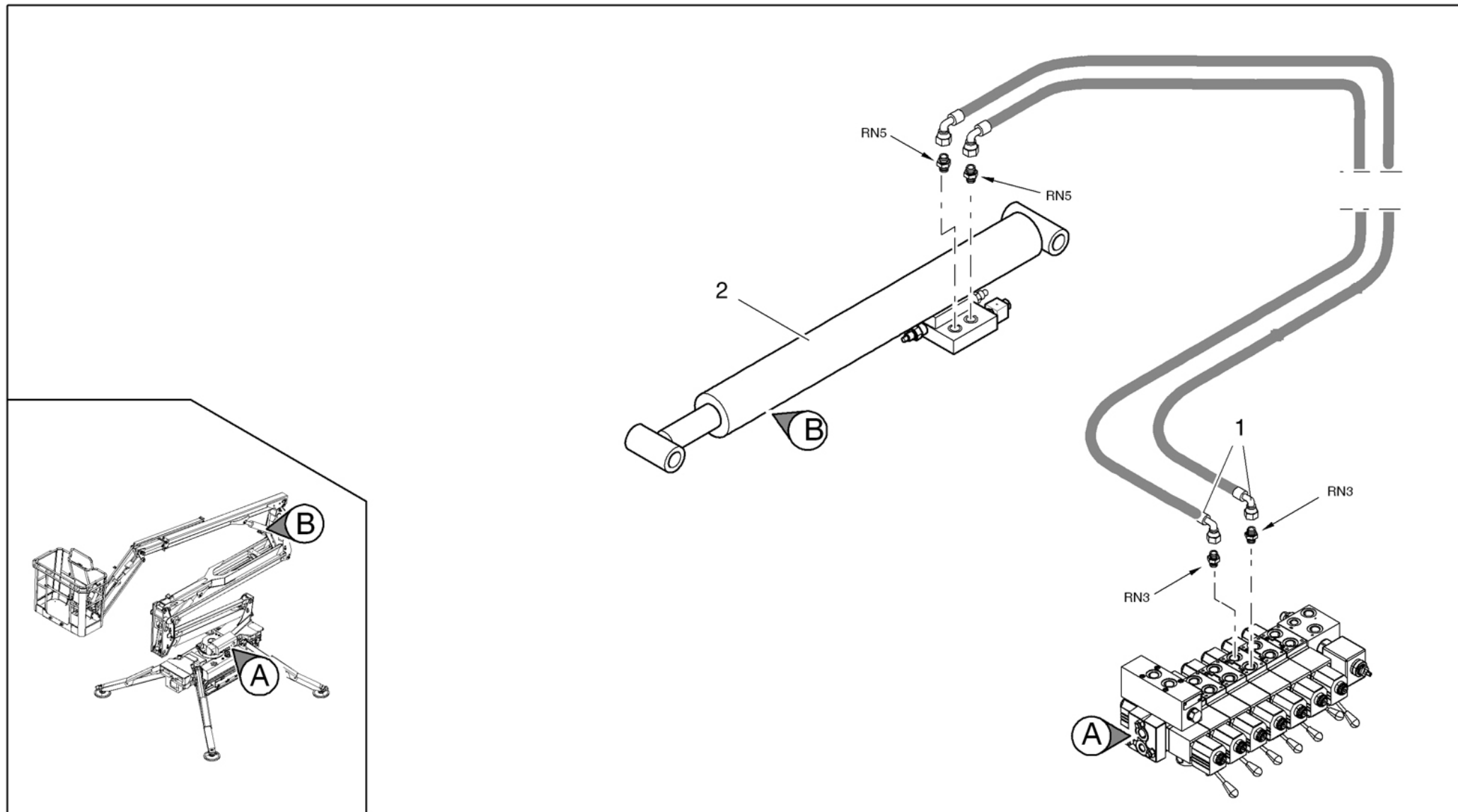
HYDRAULIKANLAGE 3 ARM   
INSTALACIÓN HIDRÁULICA 3 BRAZO 











Main color codes:  J1 - JLG Cream,  J2 - JLG Orange,  C4 - Green

 IMPIANTO IDRAULICO 3 BRACCIO

 3 ARM HYDRAULIC SYSTEM

 SYSTÈME HYDRAULIQUE 3 BRAS
HYDRAULIKANLAGE 3 ARM INSTALACIÓN HIDRÁULICA 3 BRAZO 

POS	Codice	 Descrizione	 Description	 Designation	 Benennung	 Descripción
1	07166300	TUBO FLESSIBILE	FLEXIBLE PIPE	TUYAU FLEXIBLE	SCHLAUCH	TUBO FLEXIBLE
1	07724200	TUBO FLESSIBILE (MK2 FROM C170000893)	FLEXIBLE PIPE (MK2 FROM C170000893)	TUYAU FLEXIBLE (MK2 FROM C170000893)	SCHLAUCH (MK2 FROM C170000893)	TUBO FLEXIBLE (MK2 FROM C170000893)
2	27069200	CILINDRO TERZO BRACCIO	MAIN BOOM CYLINDER	CYLINDRE SECT.TÉLESCOP.	TELESKOPZYLINDER	CIL. BRAZO TELESCÓP.
2	270692H2	CILINDRO TERZO BRACCIO	MAIN BOOM CYLINDER	CYLINDRE SECT.TÉLESCOP.	TELESKOPZYLINDER	CIL. BRAZO TELESCÓP.

Main color codes:  J1 - JLG Cream,  J2 - JLG Orange,  C4 - Green



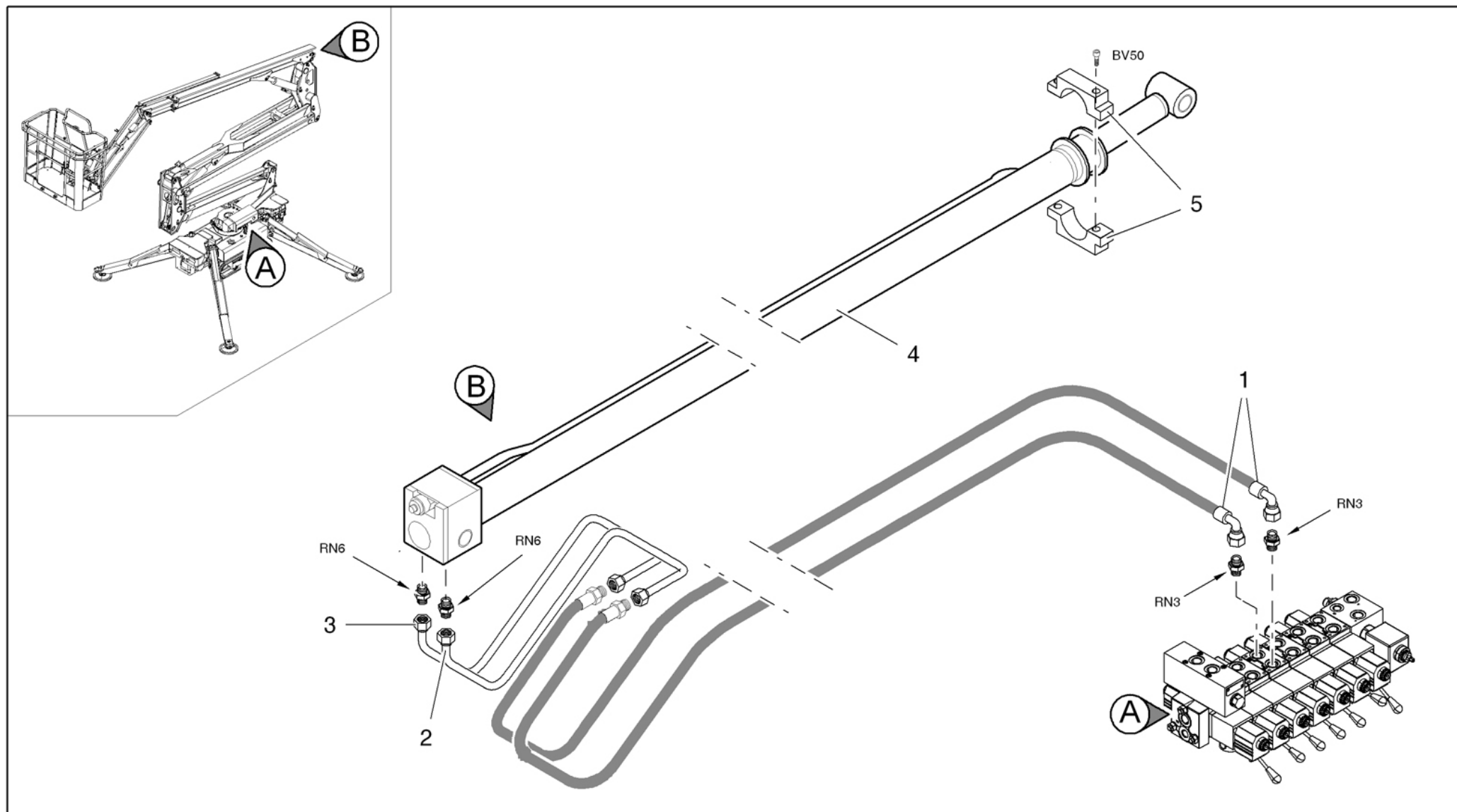





 IMPIANTO IDRAULICO SFILO





 TELESCOPIC HYDRAULIC SYSTEM

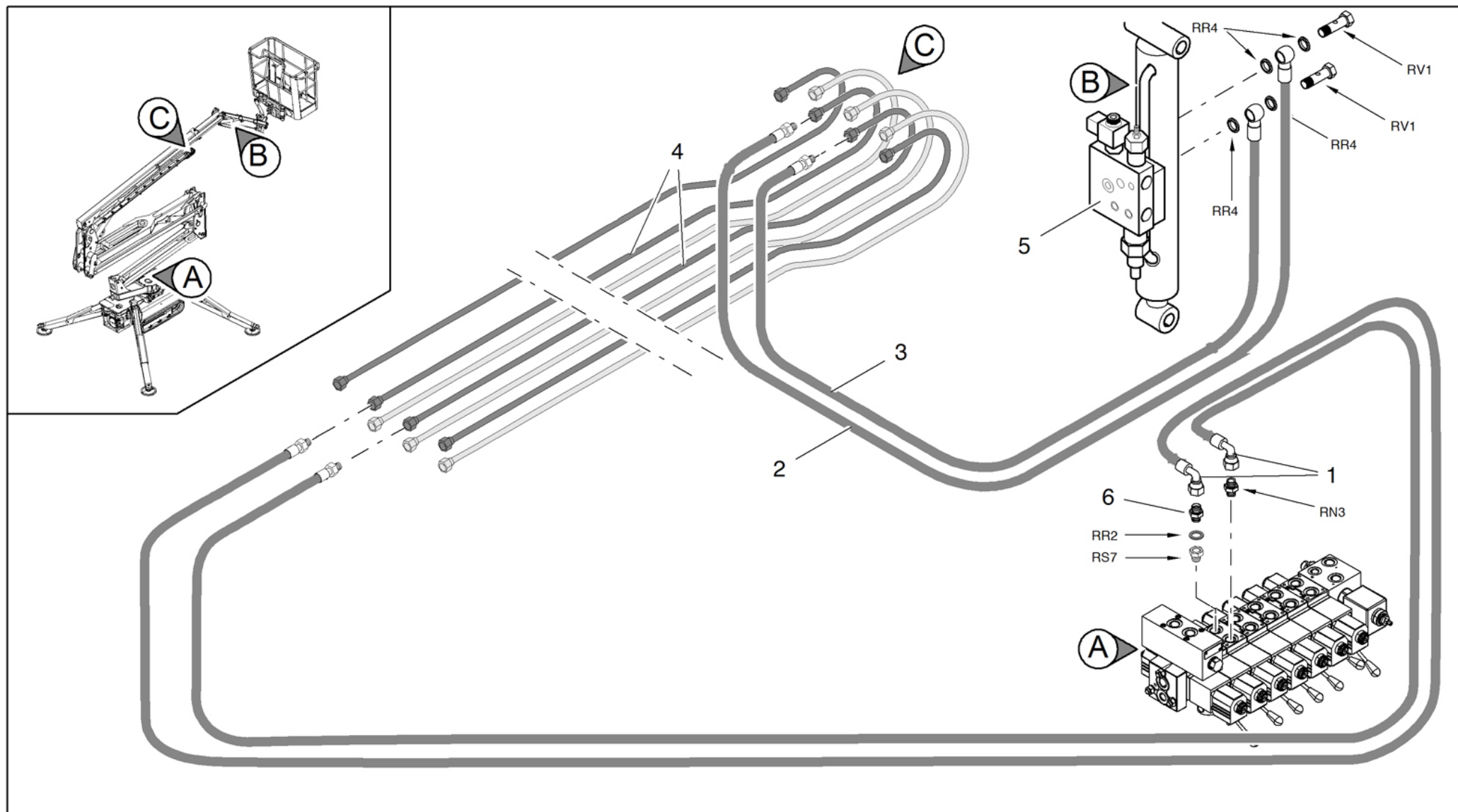

 TELESCOPIQUE HIDRAULIQUE
TELESKOPHYDRAULIK INSTALACIÓN EXTENSIÓN HIDRÁULICA 



POS	Codice	 Descrizione	 Description	 Designation	 Benennung	 Descripció
1	07169600	TUBO FLESSIBILE	FLEXIBLE PIPE	TUYAU FLEXIBLE	SCHLAUCH	TUBO FLEXIBLE
1	07724700	TUBO FLESSIBILE (MK2 FROM C170000893)	FLEXIBLE PIPE (MK2 FROM C170000893)	TUYAU FLEXIBLE (MK2 FROM C170000893)	SCHLAUCH (MK2 FROM C170000893)	TUBO FLEXIBLE (MK2 FROM C170000893)
2	07152500	TUBO RIGIDO	RIGID PIPE	TUYAU RIGIDE	ROHR	TUBO RÍGIDO
3	07152600	TUBO RIGIDO	RIGID PIPE	TUYAU RIGIDE	ROHR	TUBO RÍGIDO
4	270690H2	CILINDRO SFILO	EXTENSION CYLINDER	CYLINDRE SECT.TÉLESCOP.	TELESKOPZYLINDER	CIL. BRAZO TELESCÓP.
5	07094000	PATTINO SCORRIMENTO CILINDRO SFILO	EXT CYL. SLIDE	CHEVILLE	STIF	CLAVIJA





 IMPIANTO JIB JIB HYDRAULIC SYSTEM SYSTÈME HYDRAULIQUE JIBZYLINDER JIB ARM INSTALACIÓN HIDRÁULICA JIB 



POS	Codice	 Descrizione	 Description	 Designation	 Benennung	 Descripción
1	07167000	TUBO FLESSIBILE	FLEXIBLE PIPE	TUYAU FLEXIBLE	SCHLAUCH	TUBO FLEXIBLE
1	07724400	TUBO FLESSIBILE (MK2 FROM C170000893)	FLEXIBLE PIPE (MK2 FROM C170000893)	TUYAU FLEXIBLE (MK2 FROM C170000893)	SCHLAUCH (MK2 FROM C170000893)	TUBO FLEXIBLE (MK2 FROM C170000893)
2	07169800	TUBO FLESSIBILE	FLEXIBLE PIPE	TUYAU FLEXIBLE	SCHLAUCH	TUBO FLEXIBLE
3	07169700	TUBO FLESSIBILE	FLEXIBLE PIPE	TUYAU FLEXIBLE	SCHLAUCH	TUBO FLEXIBLE
4	07101800	TUBO RIGIDO	RIGID PIPE	TUYAU RIGIDE	ROHR	TUBO RÍGIDO
4	07876400	TUBO RIGIDO	RIGID PIPE	TUYAU RIGIDE	ROHR	TUBO RÍGIDO
5	27069500	CILINDRO JIB	JIB CYLINDER	CYLINDRE SECT.TÉLESCOP.	TELESKOPZYLINDER	CIL. BRAZO TELESCÓP.
5	270695H2	CILINDRO JIB	JIB CYLINDER	CYLINDRE JIB	KORBARMZYLINDER	CILINDRO JIB
6	06786700	RACCORDO	FITTING	RACCORD	ANSCHLUSS	CONEXIÓN



Main color codes:  J1 - JLG Cream,  J2 - JLG Orange,  C4 - Green

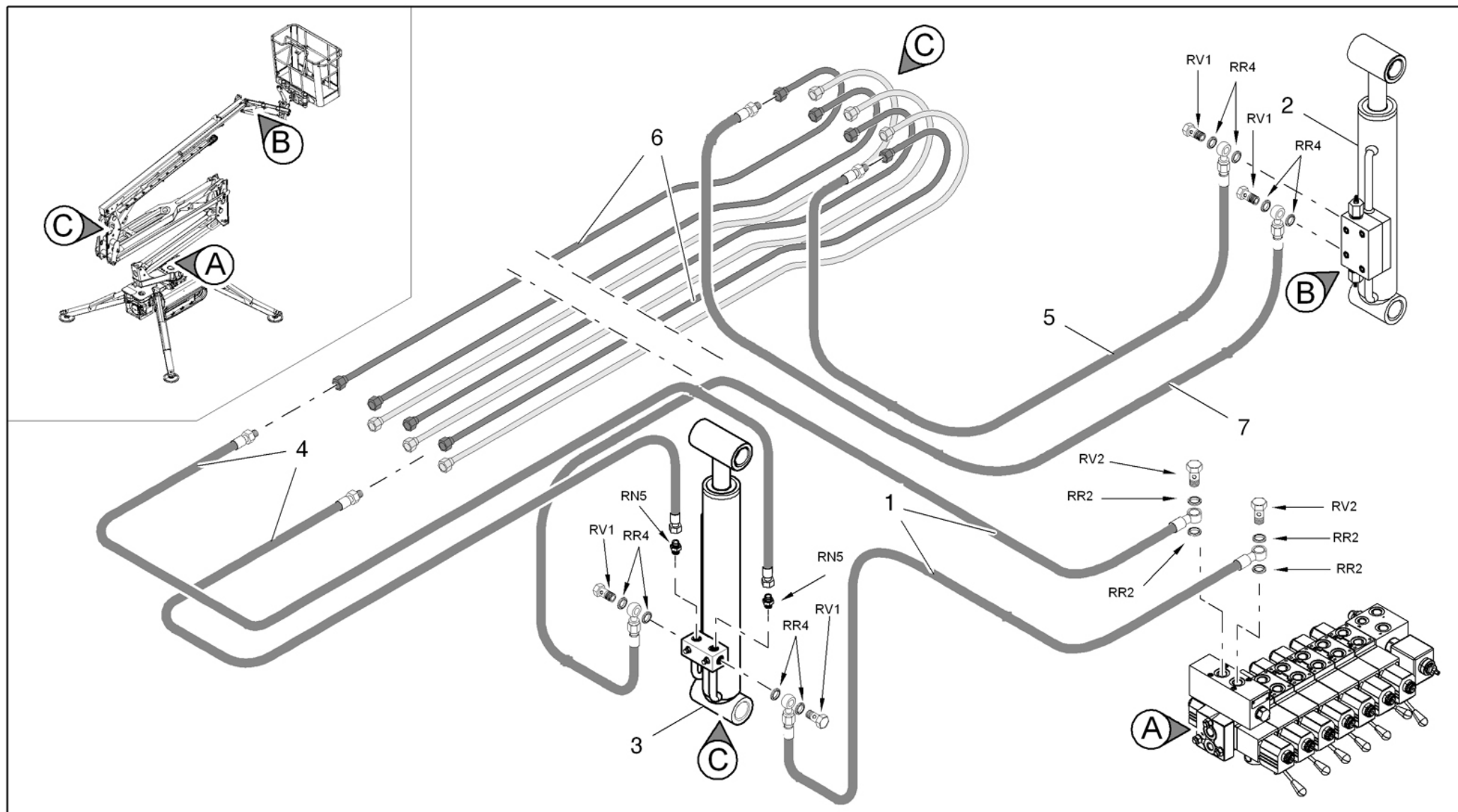

 IMPIANTO IDRAULICO LIVELLAMENTO  
 LEVELING CYLINDERS HYDRAULIC SYSTEM  
 SYSTÈME HYDRAULIQUE CYLINDRES BRAS





HYDRAULIKANLAGE ZYLINDER ARM   
 INSTALACIÓN HIDRÁULICA CILINDROS BRAZOS 







Main color codes:  J1 - JLG Cream,  J2 - JLG Orange,  C4 - Green

 IMPIANTO IDRAULICO LIVELLAMENTO  
 LEVELING CYLINDERS HYDRAULIC SYSTEM  
 SYSTÈME HYDRAULIQUE CYLINDRES BRAS



HYDRAULIKANLAGE ZYLINDER ARM   
 INSTALACIÓN HIDRÁULICA CILINDROS BRAZOS 

POS	Codice	 Descrizione	 Description	 Designation	 Benennung	 Descripción
1	07166200	TUBO FLESSIBILE	FLEXIBLE PIPE	TUYAU FLEXIBLE	SCHLAUCH	TUBO FLEXIBLE
1	07724100	TUBO FLESSIBILE (MK2 FROM C170000893)	FLEXIBLE PIPE (MK2 FROM C170000893)	TUYAU FLEXIBLE (MK2 FROM C170000893)	SCHLAUCH (MK2 FROM C170000893)	TUBO FLEXIBLE (MK2 FROM C170000893)
2	27315100	CILINDRO LIVELLAMENTO CESTO SU CESTO	LEVELING CYLINDER BASKET ON BASKET	CYLINDRE SUR LEVEL BASKET BASKET	NIVELLIERZYLINDER	CILINDRO DE NIVEL DE BASKET BASKET
2	273151H2	CILINDRO LIVELLAMENTO CESTO SU CESTO	LEVELING CYLINDER BASKET ON BASKET	CYLINDRE NIVELLEMENT PANIER SUR PANIER	ZYLINDER KORBNIVELLIERUNG	CILINDRO NIVELACIÓN CESTA
3	27069300	CILINDRO LIVELLAMENTO CESTO	LEVELLING CYLINDER	CYLINDRE SECT.TÉLESCOP.	TELESKOPZYLINDER	CIL. BRAZO TELESCÓP.
3	270693H2	CILINDRO LIVELLAMENTO CESTO	BASKET LEVELLING CYLINDER	CYLINDRE NIVELLEMENT PANIER	ZYLINDER KORBNIVELLIERUNG	CILINDRO NIVELACIÓN CESTA
4	07166900	TUBO FLESSIBILE	FLEXIBLE PIPE	TUYAU FLEXIBLE	SCHLAUCH	TUBO FLEXIBLE
4	07724300	TUBO FLESSIBILE (MK2 FROM C170000893)	FLEXIBLE PIPE (MK2 FROM C170000893)	TUYAU FLEXIBLE (MK2 FROM C170000893)	SCHLAUCH (MK2 FROM C170000893)	TUBO FLEXIBLE (MK2 FROM C170000893)
5	07169900	TUBO FLESSIBILE	FLEXIBLE PIPE	TUYAU FLEXIBLE	SCHLAUCH	TUBO FLEXIBLE
6	07101700	TUBO RIGIDO	RIGID PIPE	TUYAU RIGIDE	ROHR	TUBO RÍGIDO
6	07876500	TUBO RIGIDO	RIGID PIPE	TUYAU RIGIDE	ROHR	TUBO RÍGIDO
6	07877100	TUBO RIGIDO	RIGID PIPE	TUYAU RIGIDE	ROHR	TUBO RÍGIDO
7	07225400	TUBO FLESSIBILE	FLEXIBLE PIPE	TUYAU FLEXIBLE	SCHLAUCH	TUBO FLEXIBLE

 IMPIANTO IDRAULICO ROTAZIONE CESTO  
 CAGE ROTATION HYDRAULIC SYSTEM  
 SYSTÈME HYDRAULIQUE ROTATION PANIER

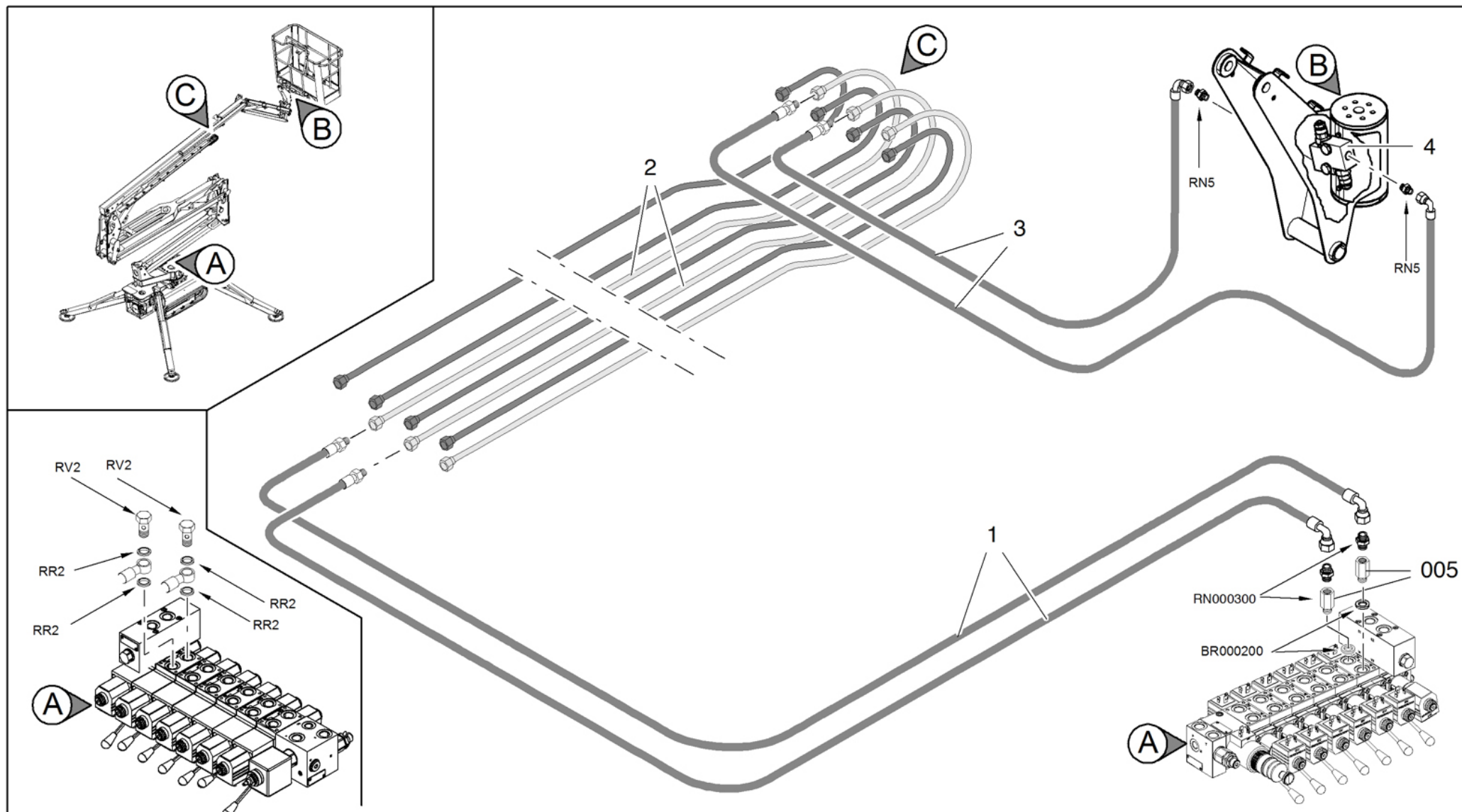
HYDRAULIKANLAGE KORBSCHWENKUNG   
 INSTALACIÓN HIDRÁULICA ROTACIÓN CESTA 









Main color codes:  J1 - JLG Cream,  J2 - JLG Orange,  C4 - Green

 IMPIANTO IDRAULICO ROTAZIONE CESTO



 CAGE ROTATION HYDRAULIC SYSTEM



 SYSTÈME HYDRAULIQUE ROTATION PANIER

 HYDRAULIKANLAGE KORBSCHWENKUNG   
 INSTALACIÓN HIDRÁULICA ROTACIÓN CESTA 



POS	Codice	 Descrizione	 Description	 Designation	 Benennung	 Descripción
1	07165300	TUBO FLESSIBILE	FLEXIBLE PIPE	TUYAU FLEXIBLE	SCHLAUCH	TUBO FLEXIBLE
1	07724500	TUBO FLESSIBILE	FLEXIBLE PIPE	TUYAU FLEXIBLE	SCHLAUCH	TUBO FLEXIBLE
2	07101400	TUBO RIGIDO	RIGID PIPE	TUYAU RIGIDE	ROHR	TUBO RÍGIDO
2	07876600	TUBO RIGIDO	RIGID PIPE	TUYAU RIGIDE	ROHR	TUBO RÍGIDO
3	07170000	TUBO FLESSIBILE	FLEXIBLE PIPE	TUYAU FLEXIBLE	SCHLAUCH	TUBO FLEXIBLE
4	2648910001	VALVOLA IDRAULICA	HYDRAULIC VALVE	VALVE HYDRAULIQUE	HYDRAULIKVENTIL	VÁLVULA HIDRÁULICA
5	03149500	RACCORDO A COLONNA 3/8" H=20	EXTENSION 3/8" H=20	RACCORD	ANSCHLUSS	CONEXIÓN

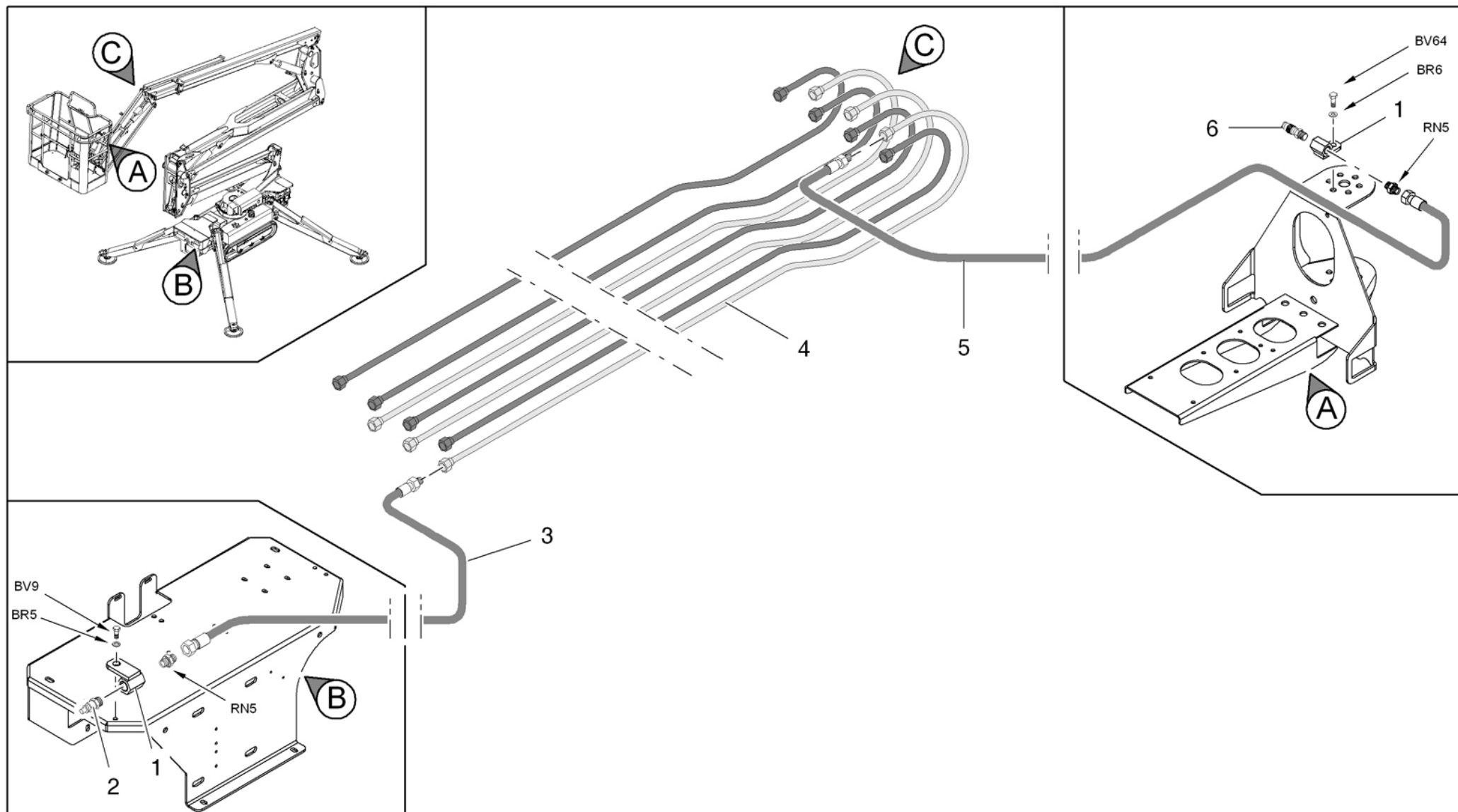

 IMPIANTO IDRAULICO ARIA COMPRESSA  
 COMPRESSED AIR HYDRAULIC SYSTEM  
 SYSTÈME HYDRAULIQUE AIR COMPRIMÉ

HYDRAULIKANLAGE DRUCKLUFT   
 INSTALACIÓN HIDRÁULICA AIRE COMPRIMIDO 



**Main color codes:**  J1 - JLG Cream,  J2 - JLG Orange,  C4 - Green





 IMPIANTO IDRAULICO ARIA COMPRESSA

 COMPRESSED AIR HYDRAULIC SYSTEM



 SYSTÈME HYDRAULIQUE AIR COMPRIMÉ

 HYDRAULIKANLAGE DRUCKLUFT

 INSTALACIÓN HIDRÁULICA AIRE COMPRIMIDO

POS	Codice	 Descrizione	 Description	 Designation	 Benennung	 Descripción
1	04845100	SUPPORTO	SUPPORT	SUPPORT	HALTERUNG	SOPORTE
1	079331Y1	SUPPORTO PRESA ARIA-ACQUA	AIR-WATER CONNECTION BRACKET	SUPPORT DE RACCORDEMENT AIR-EAU	LUFT-WASSER VERBINDUNG HALTERUNG	SOPORTE DE CONEXION AIRE-AGUA
2	05509900	INNESTO RAPIDO	QUICK COUPLING	RACCORD RAPIDE	SCHNELLKUPPLUNG	CONEXIÓN RÁPIDA
2	07611000	RACCORDO	PIPE FITTING	TUYAU	ANSCHLUSS	MANGUITO
3	07169500	TUBO FLESSIBILE	FLEXIBLE PIPE	TUYAU FLEXIBLE	SCHLAUCH	TUBO FLEXIBLE
3	07724600	TUBO FLESSIBILE	FLEXIBLE PIPE	TUYAU FLEXIBLE	SCHLAUCH	TUBO FLEXIBLE
3	07908900	TUBO FLESSIBILE	FLEXIBLE PIPE	TUYAU FLEXIBLE	SCHLAUCH	TUBO FLEXIBLE
4	07101300	TUBO RIGIDO	RIGID PIPE	TUYAU RIGIDE	ROHR	TUBO RÍGIDO
4	07875800	TUBO RIGIDO	RIGID PIPE	TUYAU RIGIDE	ROHR	TUBO RÍGIDO
4	07876700	TUBO RIGIDO	RIGID PIPE	TUYAU RIGIDE	ROHR	TUBO RÍGIDO
5	07170100	TUBO FLESSIBILE	FLEXIBLE PIPE	TUYAU FLEXIBLE	SCHLAUCH	TUBO FLEXIBLE
5	07909000	TUBO FLESSIBILE	FLEXIBLE PIPE	TUYAU FLEXIBLE	SCHLAUCH	TUBO FLEXIBLE
6	05580200	RUBINETTO	FAUCET	ROBINET	WASSERHAHN	GRIFO
6	07611100	RACCORDO	HOSE FITTING	TUYAU	ANSCHLUSS	CONEXIÓN

 CILINDRI  
 CYLINDERS  
 CYLINDRES

ZYLINDER   
 CILINDROS 

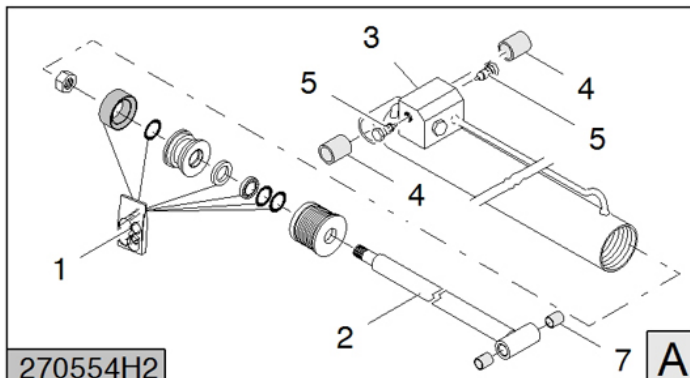

270554H2

A

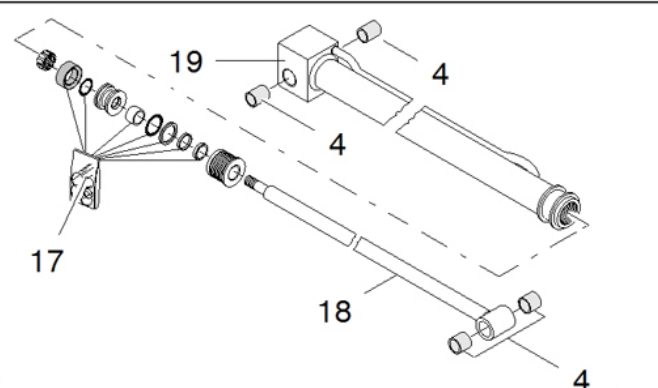

270690H2

D

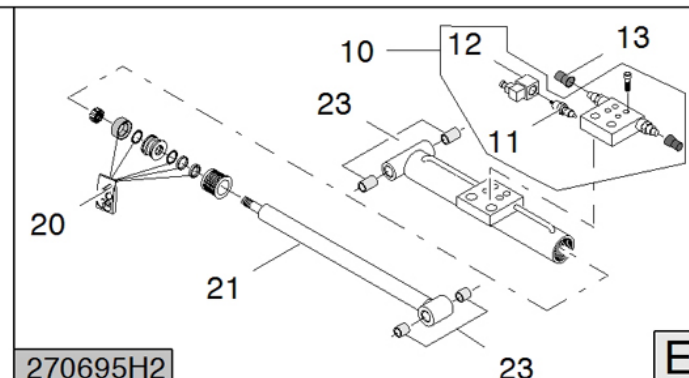

270695H2

E

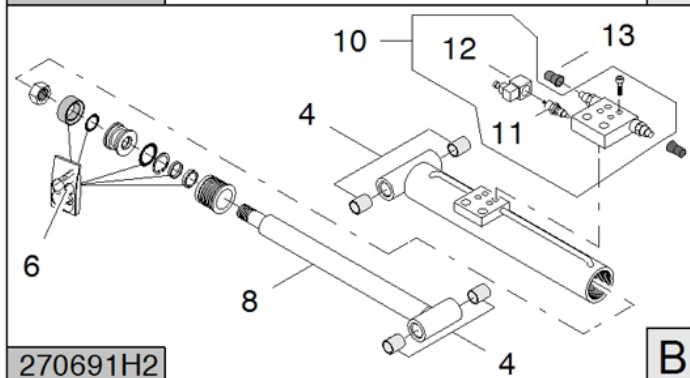

270691H2

B

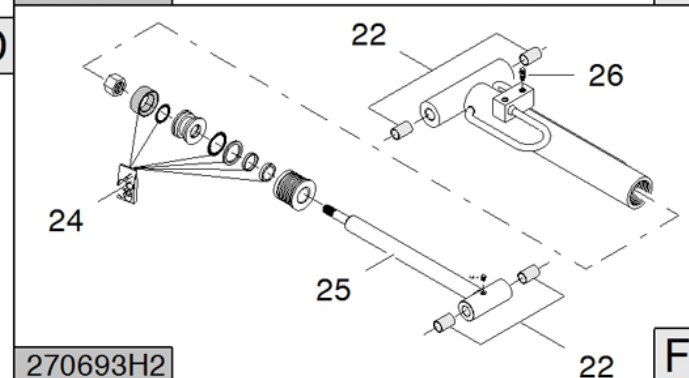
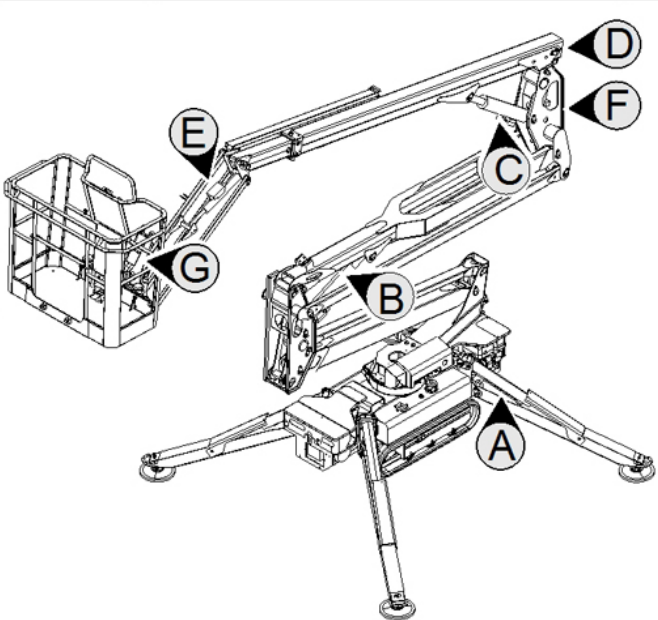

270693H2

F

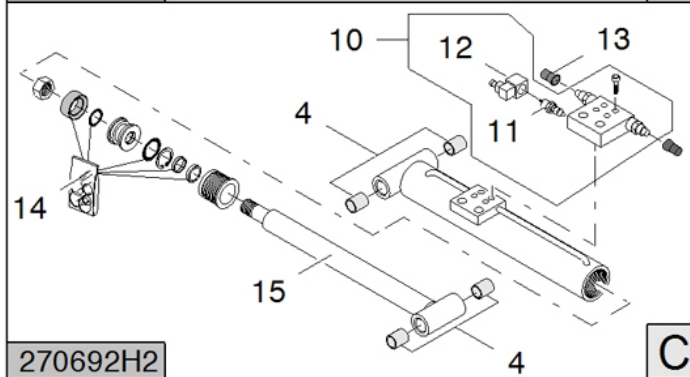

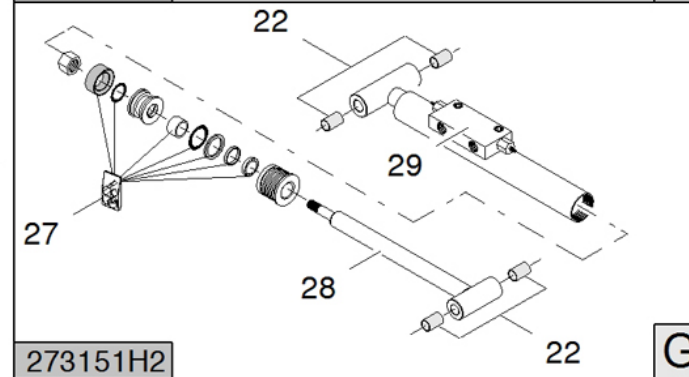

270692H2

C





273151H2



G

Main color codes:  J1 - JLG Cream,  J2 - JLG Orange,  C4 - Green

 CILINDRI  
 CYLINDERS  
 CYLINDRES

ZYLINDER   
 CILINDROS 

POS	Codice	 Descrizione	 Description	 Designation	 Benennung	 Descripción
1	2705540001	KIT GUARNIZIONI	GASKET KIT	KIT JOINTS	DICHTUNGSSATZ	KIT GUARNICIONES
2	2687630002	STELO	ROD	TIGE	SCHAFT	VÁSTAGO
3	2705540002	BLOCCETTO	BLOCK	BLOC	BLOCK	BLOQUE
4	2627880005	BOCCOLA	BUSH	DOUILLE	BUCHSE	CASQUILLO
5	1541150011	VALVOLA IDRAULICA	HYDRAULIC VALVE	VALVE HYDRAULIQUE	HYDRAULIKVENTIL	VÁLVULA HIDRÁULICA
6	2706910001	KIT GUARNIZIONI CILINDRO 1-2 BRACCIO	1-2 ARM CYLINDER GASKET KIT	SEAL KIT CYLINDRE 1-2 ARM	1-2 ARM ROLLSIEGEL BAUSÄTZE	1-2 ARM KIT DE JUNTAS CILINDRO
7	2626900002	BOCCOLA	BUSH	DOUILLE	BUCHSE	CASQUILLO
8	2706910002	STELO CILINDRO 1-2 BRACCIO	CYLINDER 1-2 ARM ROD	TIGE DU VERIN 1-2 ARM	ROD CYLINDER 1-2 ARM	VÁSTAGO DEL CILINDRO 1-2 ARM
10	26119300	VALVOLA IDRAULICA	HYDRAULIC VALVE	VALVE HYDRAULIQUE	HYDRAULIKVENTIL	VÁLVULA HIDRÁULICA
11	0552550001	ELETTROVALVOLA	SOLENOID VALVE	ÉLECTROVANNE	MAGNETVENTIL	ELECTROVÁLVULA
12	0552550003	BOBINA	COIL	BOBINE	SPULE	BOBINA
13	05576200	PROTEZIONE	PROTECTION	PROTECTION	SCHUTZ	PROTECCIÓN
14	2706920001	KIT GUARNIZIONI CILINDRO 3 BRACCIO	3 ARM CYLINDER GASKET KIT	TIGE DU VERIN 1-2 ARM	ROD CYLINDER 1-2 ARM	VÁSTAGO DEL CILINDRO 1-2 ARM
15	2706920002	STELO CILINDRO 3 BRACCIO	3 ARM CYLINDER ROD	3 BRAS DE TIGE DU VERIN	3 ZYLINDER ROD ARM	3 ARM VÁSTAGO DEL CILINDRO
15	2706920003	SENSORE LINEARE CILINDRO	CYLINDER LINEAR SENSOR	CAPTEUR	SENSOR	SENSOR
17	2706900001	KIT GUARNIZIONI CILINDRO SFILO	GASKET KIT CYLINDER EXTENSION	CYLINDRE JOINT KIT D'EXTENSION	CYLINDER GASKET BAUSÄTZE EXTENSION	EXTENSION KIT DE JUNTAS CILINDRO
18	2706900002	STELO CILINDRO SFILO	CYLINDER EXTENSION ROD	TIGE D'EXTENSION DE CYLINDRE	KOLBENSTANGE EXTENSION	EXTENSION ROD CILINDRO
19	2706900003	BLOCCO VALVOLA RIGENERATRICE CILINDRO SFILO	CYLINDER VALVE EXTENSION REGENERATIVE	SERRURE A CYLINDRE REGENERATIVE EXTENSION VALVE	SCHLIESSZYLINDER VALVE EXTENSION REGENERATIVE	QUEO DEL CILINDRO DE EXTENSIÓN DE LA VÁLVULA REGENERATIVA
20	2706950001	KIT GUARNIZIONI CILINDRO JIB	SEAL KIT CYLINDER JIB	KIT DE JOINTS	DICHTUNGSSATZ	KIT JUNTAS CILINDRO JIB



Main color codes:  J1 - JLG Cream,  J2 - JLG Orange,  C4 - Green

 CILINDRI  
 CYLINDERS  
 CYLINDRES

ZYLINDER   
 CILINDROS 



POS	Codice	 Descrizione	 Description	 Designation	 Benennung	 Descripción
21	2706950002	STELO CILINDRO JIB	ROD CYLINDER JIB	TIGE DE CYLINDRE JIB	KORBARM ZYLINDERSCHAFT	VASTAGO CILINDRO JIB
22	2627890006	BOCCOLA	BUSH	DOUILLE	BUCHSE	CASQUILLO
23	2627910006	BOCCOLA	BUSH	DOUILLE	BUCHSE	CASQUILLO
24	2706930001	KIT GUARNIZIONI CILINDRO LIVELLAMENTO SU RINVIO	CYLINDER GASKET KIT	KIT DE JOINTS CYLINDRE NIVELLEMENT	DICHTSATZ ZYLINDER AUSNIVELLIERUNG	KIT DE JUNTAS CILINDRO NIVELACIÓN
25	2706930002	STELO CILINDRO LIVELLAMENTO SU RINVIO	ROD CYLINDER	TIGE CYLINDRE	ZYLINDERSCHAFT	VASTAGO CILINDRO
26	2588290008	VITE	SCREW	VIS	SCHRAUBE	TORNILLO
27	2706940001	KIT GUARNIZIONI CILINDRO LIVELLAMENTO SU CESTO	CYLINDER GASKET KIT	KIT DE JOINTS CYLINDRE NIVELLEMENT	DICHTSATZ	KIT JUNTAS
28	2706940002	STELO CILINDRO LIVELLAMENTO SU CESTO	BASKET LEVELING CYLINDER ROD ON BASKET	CYLINDRE TIGE	ZYLINDERSCHAFT	VASTAGO CILINDRO
29	2731510003	VALVOLA IDRAULICA	HYDRAULIC VALVE	VALVE HYDRAULIQUE	HYDRAULIKVENTIL	VÁLVULA HIDRÁULICA

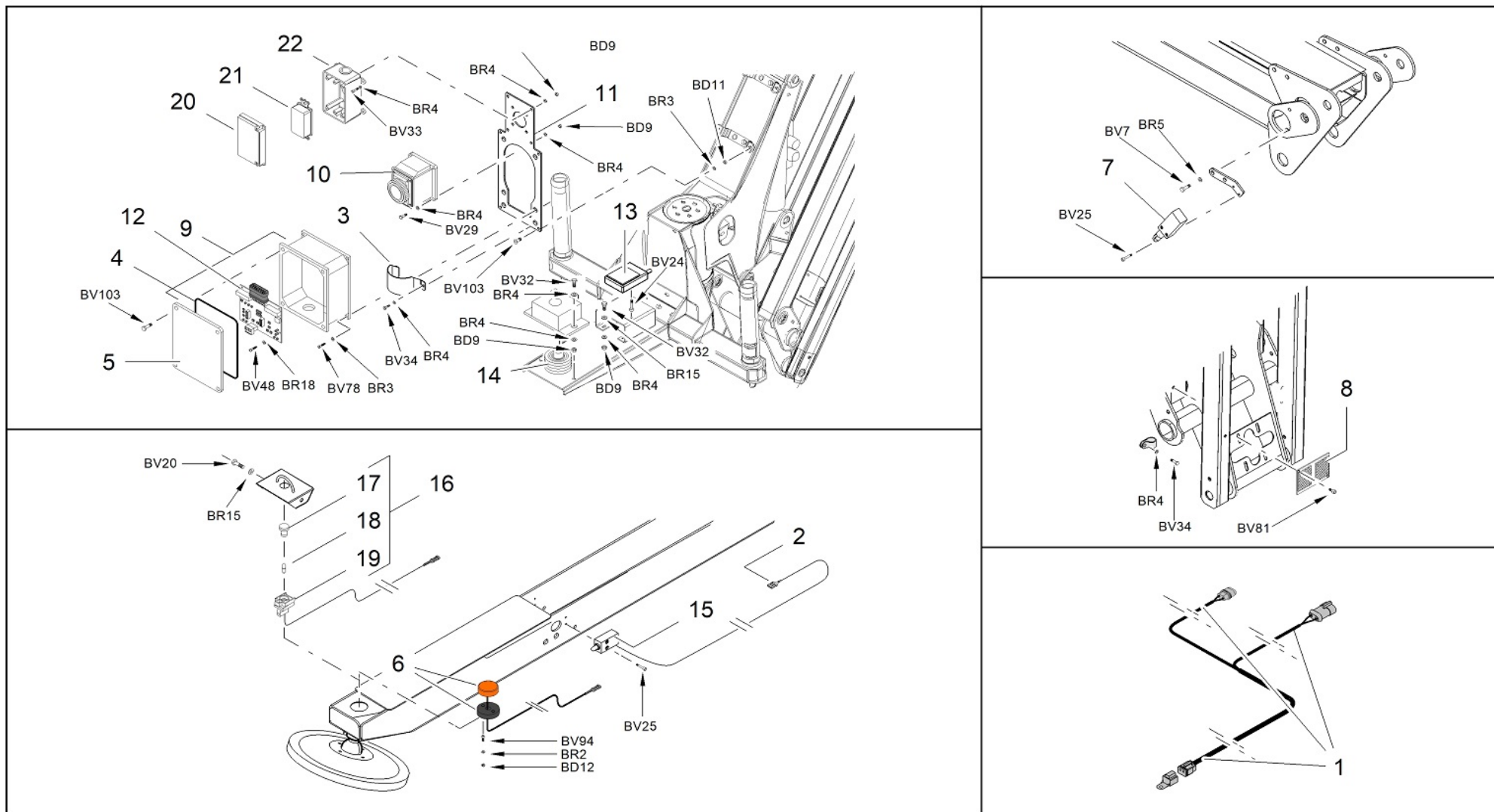

 COMPONENTI IMPIANTO ELETTRICO  
 ELECTRICAL SYSTEM COMPONENTS  
 COMPOSANTS INSTALLATION ÉLECTRIQUE

KOMPONENTEN ELEKTROANLAGE   
 COMPONENTES INSTALACIÓN ELÉCTRICA 









Main color codes:  J1 - JLG Cream,  J2 - JLG Orange,  C4 - Green



 COMPONENTI IMPIANTO ELETTRICO

 ELECTRICAL SYSTEM COMPONENTS

 COMPOSANTS INSTALLATION ÉLECTRIQUE

 KOMponenten Elektroanlage   
 Componentes Instalación Eléctrica 

POS	Codice	 Descrizione	 Description	 Designation	 Benennung	 Descripción
1	17727200	PROLUNGA PER LAMPEGGIANTE	CABLE EXTENSION FOR BEACON	RALLONGE	VERLÄNGERUNG	CABLE DE EXTENSIÓN
2	1730720085	CAVO STABILIZZATORE COMPLETO DI CONNETTORE E MICRO	STABILIZER CABLE WITH CONNECTOR AND MICRO	CONNECTEUR AVEC STABILISATEUR ET MICRO	KABELSTECKER MIT STABILISATOR UND MICRO	CABLE CONECTOR CON ESTABILIZADOR Y MICRO
2	1764250005	CAVO STABILIZZATORE COMPLETO DI CONNETTORE E MICRO PER LUCE A LED MK2 (DA C170000893)	STABILIZER CABLE WITH CONNECTOR AND MICRO FOR LED MK2 (FROM C170000893)	CONNECTEUR AVEC STABILISATEUR ET MICRO LED MK2 (FROM C170000893)	KABELSTECKER MIT STABILISATOR UND MICRO LED MK2 (FROM C170000893)	CABLE CONECTOR CON ESTABILIZADOR Y MICRO LED MK2 (FROM C170000893)
3	075163H3	PROTEZIONE CONNETTORI SCATOLA CELLA DICARICO MK2 (DA C170000893)	PROTECTION LOAD CELL CONNECTOR MK2 (FROM C170000893)	PROTECTION CONNECTEURS BOITE CELLULE DE CHARGE MK2 (FROM C170000893)	ABDECKUNG MK2 (FROM C170000893)	PROTECCION MK2 (FROM C170000893)
3	075914B8	PROTEZIONE CONNETTORI SCATOLA CELLA DICARICO AFTERMARKET	PROTECTION LOAD CELL CONNECTOR AFTER MARKET	PROTECTION CONNECTEURS BOITE CELLULE DE CHARGE	ABDECKUNG	PROTECCION
4	07141800	GUARNIZIONE SCATOLA CELLA DI CARICO IN ALLUMINIO	SEAL BOX ALUMINUM LOAD CELL	JOINT	DICHTUNG	SELLO
5	07141700	COPERCHIO SCATOLA CELLA DI CARICO IN ALLUMINIO	BOX COVER ALUMINUM LOAD CELL	COUVERCLE DE LA BOÎTE ALUMINIUM	SCHACHTELDECKEL ALUMINIUM	TAPA CAJA DE ALUMINIO



 Main color codes:  J1 - JLG Cream,  J2 - JLG Orange,  C4 - Green











 COMPONENTI IMPIANTO ELETTRICO

 ELECTRICAL SYSTEM COMPONENTS

 COMPOSANTS INSTALLATION ÉLECTRIQUE

 KOMponenten Elektroanlage   
 Componentes Instalación Eléctrica 



POS	Codice	 Descrizione	 Description	 Designation	 Benennung	 Descripción
6	1757250023	SPIA STABILIZZATORE LED COMPLETA DI CONNETTORE	LED LIGHT	TEMOIN LED	KONTROLLLAMPE	INDICADOR LED
7	1591270003	MICROINTERRUTTOR E 2 CONTATTI NC TESTINA ROTELLA ACCIAIO CAVO LUNGO 2 METRI	MICROSWITCH 2 NC CONTACTS HEAD STEEL WHEEL LONG CABLE 2M	MICROINTERRUPTEUR	MIKROSCHALTER	MICROINTERRUPTOR
8	1679890001	CATARIFRANGENTE 100X100 MM	REFLECTOR 100X100 MM	CATADIOPTRE	REFLEKTOR	CATADIÓPTRICO
9	1764250002	SCATOLA ALLUMINIO PER SCHEDA CELLA DI CARICO MV/V 2 CONNETTORI COMPLETA DI IMPIANTO, CONNETTORI E COPERCHIO (FINO A SC C170000893)	ALUMINUM BOX FOR LOAD CELL BOARD MV/V 2 CONNECTORS COMPLETE WITH SYSTEM, CONNECTORS AND COVER (UNTIL SN C170000893)	BOÎTE	GEHÄUSE	CAJA
9	17644500	SCATOLA ALLUMINIO PER SCHEDA CELLA DI CARICO IMPIANTI CON DOPPIO CONNETTORE PER SENSORE CELLA	BOX ALUMINUM SHEET LOAD CELL SYSTEMS WITH DUAL SENSOR CONNECTOR FOR CELL	BOÎTE ÉLECTRIQUE	ELEKTROGEHÄUSE	CAJA ELÉCTRICA
9	1779600003	SCATOLA CELLA DI CARICO 4-20MA COMPLETA DI CABLAGGIO INTERNO PER MK2 (NO TTC)	LOAD CELL BOARD 4- 20MA BOX WITH INTERNAL WIRING FOR MK2 (NO TTC)	BOÎTE CELLULE DE CHARGE	SCHALTKASTEN LASTÜBERWACHUNG SZELLE	CAJA CÉLULA DE CARGA
10	1585570005	PRESA ELETTRICA 230V	ELECTRICAL SOCKET 230V	PRISE ÉLECTRIQUE	STECKDOSE	ENCHUFE ELÉCTRICO





 Main color codes:  J1 - JLG Cream,  J2 - JLG Orange,  C4 - Green

 COMPONENTI IMPIANTO ELETTRICO

 ELECTRICAL SYSTEM COMPONENTS

 COMPOSANTS INSTALLATION ÉLECTRIQUE



 KOMponenten Elektroanlage   
 Componentes Instalación Eléctrica 





POS	Codice	 Descrizione	 Description	 Designation	 Benennung	 Descripción
10	1591700002	PRESA ELETTRICA 110V	ELECTRICAL SOCKET 110V	PRISE ÉLECTRIQUE 110V	STECKDOSE 110V	ENCHUFE ELÉCTRICO 110V
11	07173300	PIASTRA VERSIONE CE	PLATE CE VERSION	PLATINE	PLATTE	PLACA
11	07173800	PIASTRA VERSIONE ANSI	PLATE ANSI VERSION	PLATINE	PLATTE	PLACA
11	076710H3	LAMIERA FISSAGGIO SCATOLA MK2 (DA C170000893)	PROTECTION MK2 (FROM C170000893)	PROTECTION MK2 (FROM C170000893)	SCHUTZ MK2 (FROM C170000893)	PROTECCION MK2 (FROM C170000893)
11	076860H3	LAMIERA FISSAGGIO SCATOLA MK2 (DA C170000893)	PLATE MK2 (FROM C170000893)	PLAQUE MK2 (FROM C170000893)	PLATTE MK2 (FROM C170000893)	PLACA MK2 (FROM C170000893)
12	1764250007	RELE'	RELE'	RELAIS	RELAIS	RELÉ
12	17770300	SCHEDA CELLA DI CARICO 4-20MA RESINATA (MK2)	ELECTRONIC BOARD LOAD SENSOR 4-20MA (MK2)	CARTE ÉLECTRONIQUE (MK2)	ELEKTRONISCHE PLATINE (MK2)	PLACA ELECTRÓNICA (MK2)
12	27480300	SCHEDA ELETTRONICA SENSORE DI CARICO (PERFORMANCE- PLUS-AUSTRALIA)	ELECTRONIC BOARD LOAD SENSOR (PERFORMANCE- PLUS-AUSTRALIA)	CARTE ÉLECTRONIQUE	ELEKTRONISCHE PLATINE	PLACA ELECTRÓNICA
13	27031700	INTERUTTORE A PEDALE	FOOT SWITCH	INTERRUPTEUR	FUßSCHALTER	INTERRUPTOR
14	1730720095	SENSORE CELLA DI CARICO COMPLETA DI CAVO E CONNETTORE CABLATO PERFORMANCE E PLUS	SENSOR LOAD CELL COMPLETE WIRED CABLE AND CONNECTOR FOR PERFORMANCE AND PLUS	CAPTEUR CELLULE DE CHARGE COMPLÈTE DE CÂBLE ET CONNECTEUR AVEC CÂBLAGE PERFORMANCE ET PLUS	KORBLASTSENSOR KOMPLETT MIT KABEL UND VERBINDER FÜR PERFORMANCE UND PLUS	SENSOR CÉLULA DE CARGA COMPLETA DE CABLE Y CONECTOR CABLEADO PERFORMANCE Y PLUS



 COMPONENTI IMPIANTO ELETTRICO

 ELECTRICAL SYSTEM COMPONENTS



 COMPOSANTS INSTALLATION ÉLECTRIQUE

 KOMONENTEN ELEKTROANLAGE   
 COMPONENTES INSTALACIÓN ELÉCTRICA 

POS	Codice	 Descrizione	 Description	 Designation	 Benennung	 Descripción
14	17669800	SENSORE CELLA DI CARICO 4-20MA COMPLETO DI CAVO E CONNETTORI M12 (MK2)	SENSOR LOAD CELL 4-20MA WITH CABLE AND CONNECTORS M12 (MK2 VERSION)	CELLULE DE CHARGE (MK2)	MESSDOSE (MK2)	CÉLULA DE CARGA (MK2)
14	25611500	CELLA DI CARICO	LOAD CELL	CELLULE DE CHARGE	MESSDOSE	CÉLULA DE CARGA
15	1591270011	MICROINTERRUTTOR E 2 CONTATTI NC TESTINA A PULSANTE CAVO LUNGO 2 METRI	MICROSWITCH 2 NC CONTACTS BUTTON HEAD LONG CABLE 2M	MICROINTERRUPTEUR	MIKROSCHALTER	MICROINTERRUPTOR
16	1556350001	LUCE STABILIZZATORE	STABILIZER LIGHT	LUMIÈRE STABILISATEUR	ABSTÜTZUNGSBELEUCHTUNG	LUZ ESTABILIZADOR
17	1556350034	SPIA	PILOT LIGHT	TÉMOIN	KONTROLLLEUCHTE	INDICADOR LUMINOSO
18	1556350035	LAMPADINA	LAMP	AMPOULE	GLÜHBIRNE	BOMBILLA
19	1556350036	CORPO	BODY	CORPS	GEHÄUSE	CUERPO
20	27073800	COVER PRESE USA AL CESTO, RECEPTACLE BOX PART N°:1671207	COVER US SOCKETS TO BASKET, RECEPTACLE BOX PART N°:1671207	PRETECTION	SCHUTZ	PROTECCIÓN
21	27073900	PLUG PRESE USA AL CESTO, RECEPTACLE PART N°:4460346	US SOCKETS TO BASKET, RECEPTACLE PART N°:4460346	PRISE	STECKDOSE	ENCHUFE
22	07980600	PRESSACAVO NPT 1/2" IP68 GRIGIO	CABLE GLAND NPT 1/2 "IP68 GRAY	PRESSE-ÉTOUPE NPT 1/2 "IP68 GRIS	KABELDRÜCKE NPT 1/2 "IP68 GRAU	PRENSAESTOPAS NPT 1/2 "IP68 GRIS
22	27073700	BOX PRESE USA AL CESTO, RECEPTACLE PART N°:0861731	US SOCKET BOX TO BASKET, RECEPTACLE PART N°:0861731	BOX PRISES	SCHACHTEL STECKDOSEN	CAJA ENCHUFES



 Main color codes:  J1 - JLG Cream,  J2 - JLG Orange,  C4 - Green

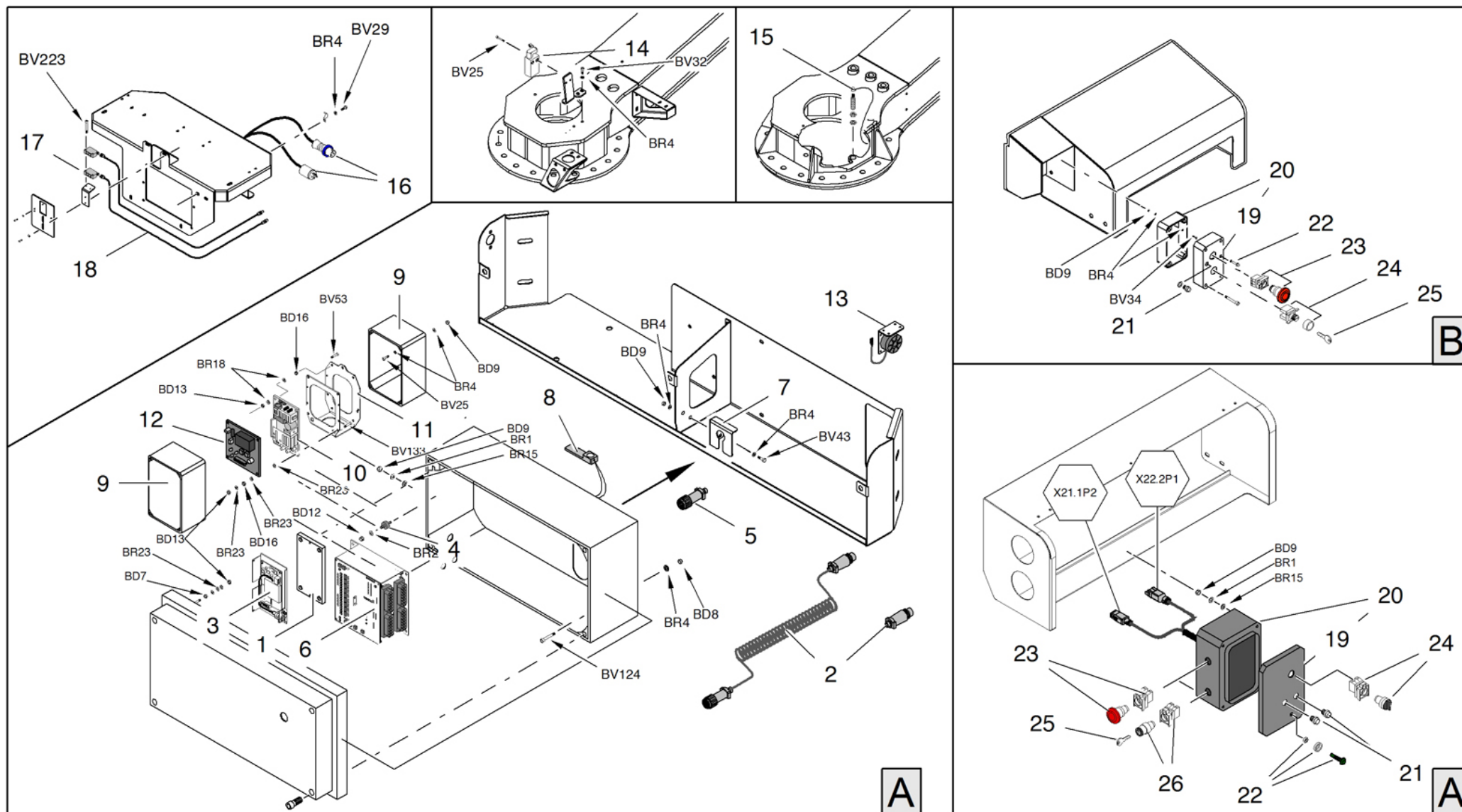

 COMPONENTI IMPIANTO ELETTRICO  
 ELECTRICAL SYSTEM COMPONENTS  
 COMPOSANTS INSTALLATION ÉLECTRIQUE

KOMPONENTEN ELEKTROANLAGE   
 COMPONENTES INSTALACIÓN ELÉCTRICA 









Main color codes:  J1 - JLG Cream,  J2 - JLG Orange,  C4 - Green



 COMPONENTI IMPIANTO ELETTRICO

 ELECTRICAL SYSTEM COMPONENTS

 COMPOSANTS INSTALLATION ÉLECTRIQUE

 KOMponenten Elektroanlage   
 Componentes Instalación Eléctrica 



POS	Codice	 Descrizione	 Description	 Designation	 Benennung	 Descripción
1	07396000	PIASTRA ADATTAMENTO	PLATE ADAPTER	REGLAGE DE LA PLAQUE	FUSSPLATTENVERSTELLUNG	AJUSTE DE LA PLACA
2	07844200	RESISTENZA 120 OHM PER CONNETTORE SERIALE RS-232	120 OHM RESISTANCE FOR CONNECTOR RS-232	120 OHM RESISTANCE POUR CONNECTEUR RS-232	120 OHM WIDERSTAND FÜR VERBINDER RS-232	RESISTENCIA 120 OHM PARA CONECTOR RS-232
2	17162400	KIT RAMHINO	RAMHINO KIT	KIT RAMHINO	KIT RAMHINO	KIT RAMHINO
2	17162500	CAVO RAMHINO SCHALTBAU	CAVO RAMHINO SCHALTBAU	CÂBLE	KABEL	CABLE
2	17264200	CAVO TELECOMANDO COMPLETO PER OPTIONAL	COMPLETE REMOTE CONTROL CABLE FOR OPTIONAL	CÂBLE TÉLÉCOMMANDE COMPLET	FERNBEDIENUNGSKABEL KOMPLETT	CABLE TELECOMANDO COMPLETO
2	2646170037	CONNETTORE PORTA MASCHI COLLEGAMENTO TELECOMANDO	CONNECTOR MALE PINS FOR REMOTE CONTROL	CONNECTEUR	VERBINGER	CONECTOR
2	26582800	ADATTATORE PCAN-USB (IPEH-002021)	ADAPTER	ADAPTEUR	ADAPTER	ADAPTADOR
3	27321800	SCHEDA MODEM CON NUOVO PROCESSORE (SUPPORTO A RICAMBIO 07396000) PER MACCHINE AUSTRALIA E PLUS	MODEM CARD WITH NEW CPU (MOUNTING SPARE PARTS 07396000) FOR AUSTRALIAN AND PLUS MACHINES	CARTE MODEM AVEC UN NOUVEAU PROCESSEUR	MODEMKARTE MIT NEUEN PROZESSOR	MODEM TARJETA CON NUEVO PROCESADOR
4	1730720018	ANTIVIBRANTE SCATOLA GENERALE SUPPORTO SCHEDA MASTER CIAM	ANTI-VIBRATING ELEMENT	INSERT EN CAOUTCHOUC	VIBRATIONSDÄMPFER	ANTIVIBRACION
5	17306800	CONNETTORE COMPLETO PER TELECOMANDO A TERRA E SERVICE	COMPLETE CONNECTOR FOR REMOTE CONTROL ON THE GROUND AND SERVICE	CONNECTEUR COMPLET	VERBINDER	CONECTOR





 Main color codes:  J1 - JLG Cream,  J2 - JLG Orange,  C4 - Green



 COMPONENTI IMPIANTO ELETTRICO

 ELECTRICAL SYSTEM COMPONENTS

 COMPOSANTS INSTALLATION ÉLECTRIQUE

 KOMponenten Elektroanlage   
 Componentes Instalación Eléctrica 

POS	Codice	 Descrizione	 Description	 Designation	 Benennung	 Descripción
6	07844200	RESISTENZA 120 OHM PER CONNETTORE SERIALE RS-232	120 OHM RESISTANCE FOR CONNECTOR RS- 232	120 OHM RESISTANCE POUR CONNECTEUR RS-232	120 OHM WIDERSTAND FÜR VERBINDER RS-232	RESISTENCIA 120 OHM PARA CONECTOR RS-232
6	17506700	KIT BANCO PROGRAMMAZIONE SCHEDE PIATTAFORME	PROGRAMMATION KIT	KIT PROGRAMMATION	PROGRAMMATIONS A TZ	KIT PROGRAMACION
6	26582800	ADATTATORE PCAN- USB (IPEH-002021)	ADAPTER	ADAPTEUR	ADAPTER	ADAPTADOR
6	27179900	SCHEDA ELETTRONICA NUOVO PROCESSORE (PER MACCHINE AUSTRALIA E PLUS)	ELECTRONIC BOARD NEW CPU (FOR AUSTRALIAN AND PLUS MACHINES)	FICHE ÉLECTRONIQUE	ELEKTRONISCHE PLATINE	TARJETA ELECTRÓNICA
6	27180000	SCHEDA ELETTRICA NUOVO PROCESSORE VERSIONE LITIO	ELECTRIC BOARD NEW CHIP LITHIUM VERSION	FICHE ÉLECTRIQUE	ELEKTRISCHE PLATINE	TARJETA ELÉCTRICA
7	073181Y1	STAFFA	BRACKET	ÉTRIER	HALTEBÜGEL	ESTRIBO
8	27396100	ANTENNA	AERIAL	ANTENNE	ANTENNE	ANTENA
9	17348200	SCATOLA ELETTRICA SWITCHING (A PARTIRE DA C170000340 PER MACCHINE ANSI)	SWITCHING ELECTRICAL BOX (FROM C170000340 FOR ANSI MACHINES)	BOÎTE ÉLECTRIQUE	ELEKTROGEHÄUSE	CAJA ELÉCTRICA
10	27249800	ALIMENTATORE SWITCHING (DA C170000340 PER MACCHINE ANSI)	SWITCHING POWER SUPPLY (FROM C170000340 FOR ANSI MACHINES)	TRANSFORMATEUR	TRANSFORMATOR	TRANSFORMADOR
11	07243300	LAMIERA SUPPORTO SCHEDA E SWITCHING (DA C170000340 PER MACCHINE ANSI)	BRACKET FOR CARD AND SWITCHING (FROM C170000340 FOR ANSI MACHINES)	SUPPORT	HALTERUNG	SOPORTE





 Main color codes:  J1 - JLG Cream,  J2 - JLG Orange,  C4 - Green

 COMPONENTI IMPIANTO ELETTRICO

 ELECTRICAL SYSTEM COMPONENTS

 COMPOSANTS INSTALLATION ÉLECTRIQUE

 KOMponenten Elektroanlage   
 Componentes Instalación Eléctrica 

POS	Codice	 Descrizione	 Description	 Designation	 Benennung	 Descripción
12	17722600	SCHEDA ELETTRONICA	ELECTRONIC BOARD	FICHE ÉLECTRIQUE	ELEKTRONISCHE PLATINE	PLACA ELECTRÓNICA
13	06639100	AVVISATORE ACUSTICO	ACOUSTIC ALARM	BUZZER	SUMMER	ZUMBADOR
14	1590900003	MICROINTERRUTTOR E 2 CONTATTI NC TESTINA BRACCIO DISASSATO E ROTELLA IN PLASTICA CAVO LUNGO 2 METRI	2 NC CONTACTS MICROSWITCH HEAD OFFSET ARM AND WHEEL PLASTIC LONG CABLE 2M	MICROINTERRUPTEUR	MIKROSCHALTER	MICROINTERRUPTOR
15	1651290010	SENSORE DI PROSSIMITÀ	PROXIMITY SENSOR	CAPTEUR DE PROXIMITÉ	NÄHERUNGSSENSOR	SENSOR DE PROXIMIDAD
16	1556350013	SPINA FISSA 230V 90°	PLUG 230V 90 °	CHEVILLE	STIFT	CLAVIJA
16	1556350064	SPINA FISSA 110V 90°	PLUG	PRISE	STECKER	ENCHUFE
16	1757250001	SPINA VOLANTE 230V 16A	FREE PLUG 230V 16A	FICHE	STECKER	ENCHUFE
16	1757250002	SPINA VOLANTE 110V 32A	FREE PLUG 110V 32A	CHEVILLE	STIF	CLAVIJA
16	1757250003	SPINA VOLANTE 110V 16A	FREE PLUG 110V 16A	CHEVILLE	STIF	CLAVIJA
16	27074000	TERMINAL PRESA USA A TERRA, CONN PLUG PART N°:4460138	TERMINAL GROUND SOCKET USA, CONN PLUG PART N °: 4460138	CONNECTEUR	VERBINDER	CONECTOR
17	1591270001	FOTOCCELLULA	PHOTOCELL	CELLULE PHOTO-ÉLECTRIQUE	PHOTOZELLE	FOTOCÉLULA
18	159127000101	CAVO ELETTRICO	ELECTRIC CABLE	CÂBLE ÉLECTRIQUE	ELEKTROKABEL	CABLE ELÉCTRICO
19	175726002401	COPERCHIO SCATOLA STOP A TERRA DIESEL LL2614-X26JP-X770AJ	BOX COVER	COUVERCLE BOÎTE	KASTENABDECKUNG	TAPA DE CAJA











 COMPONENTI IMPIANTO ELETTRICO

 ELECTRICAL SYSTEM COMPONENTS





 COMPOSANTS INSTALLATION ÉLECTRIQUE



 KOMponenten Elektroanlage   
 Componentes Instalación Eléctrica 



POS	Codice	 Descrizione	 Description	 Designation	 Benennung	 Descripción
19	175727000201	COPERCHIO SCATOLA STOP A TERRA LITHIUM 83V	BOX COVER	COUVERCLE BOÎTE	KASTENABDECKUNG	TAPA DE CAJA
20	1730720011	SCATOLA STOP A TERRA BENZINA/DIESEL COMPLETA DI CABLAGGIO E CONNETTORE	BOX GROUND STOP PETROL / DIESEL COMPLETE WIRING AND CONNECTOR	CONNECTEUR	VERBINDER	CONECTOR
20	173072001101	SCATOLA VUOTA STOP A TERRA BENZINA/DIESEL	BOX GROUND STOP PETROL / DIESEL	BOÎTE	GEHÄUSE	CAJA
20	1730720093	SCATOLA STOP A TERRA LITHIUM COMPLETA DI CABLAGGIO E CONNETTORE	BOX GROUND STOP LITHIUM COMPLETE WIRING AND CONNECTOR	BOITE	GEHÄUSE	CAJA
20	1757260024	SCATOLA STOP A TERRA DIESEL LL2614-X26JP-X770AJ COMPLETA DI CABLAGGIO E CONNETTORE	BOX WITH WIRING	BOÎTE AVEC CÂBLAGE	KASTEN MIT VERKABELUNG	CAJA CON CABLEADO
20	175726002402	SCATOLA STOP A TERRA MK2 E LL2614 VUOTA	STOP BOX MK2 AND LL2614 EMPTY	BOÎTE STOP	KASTEN STOP	CAJA STOP
20	1757270002	SCATOLA STOP A TERRA LITHIUM 83V COMPLETA DI CABLAGGIO E CONNETTORE	BOX WITH WIRING	BOÎTE AVEC CÂBLAGE	KASTEN MIT VERKABELUNG	CAJA CON CABLEADO
21	1628400005	PULSANTE	BUTTON	BOUTON	DRUCKKNOPF	BOTÓN
22	1730720005	SPIA VERDE PARTE AEREA GRANDE	BIG GREEN LIGHT AERIAL PART	VOYANT	KONTROLLLEUCHTE	INDICADOR



 Main color codes:  J1 - JLG Cream,  J2 - JLG Orange,  C4 - Green

 COMPONENTI IMPIANTO ELETTRICO ELECTRICAL SYSTEM COMPONENTS COMPOSANTS INSTALLATION ÉLECTRIQUEKOMPONENTEN ELEKTROANLAGE   
COMPONENTES INSTALACIÓN ELÉCTRICA 



POS	Codice	 Descrizione	 Description	 Designation	 Benennung	 Descripción
22	18096200	KIT ELETTRICO SPIA ROSSA LAMPEGGIANTE PER MACCHINE AUSTRALIA	ELECTRIC LIGHT BLINKING KIT FOR AUSTRALIA MACHINES	KIT ELECTRIQUE	ELEKTRISCHES KIT	KIT ELECTRICO
23	1591270004	PULSANTE	BUTTON	BOUTON	DRUCKKNOPF	BOTÓN
24	1556350068	SELETTORE A LEVA 3 POSIZIONI	3 POSITION LEVER SWITCH	SÉLECTEUR	WÄHLSCHALTER	SELECTOR
25	1651290015	CHIAVE	KEY	CLÉ	SCHLÜSSEL	LLAVE
26	1692150001	BLOCCHETTO	BLOCK	BLOC	BLOCK	BLOQUE



Main color codes:  J1 - JLG Cream,  J2 - JLG Orange,  C4 - Green

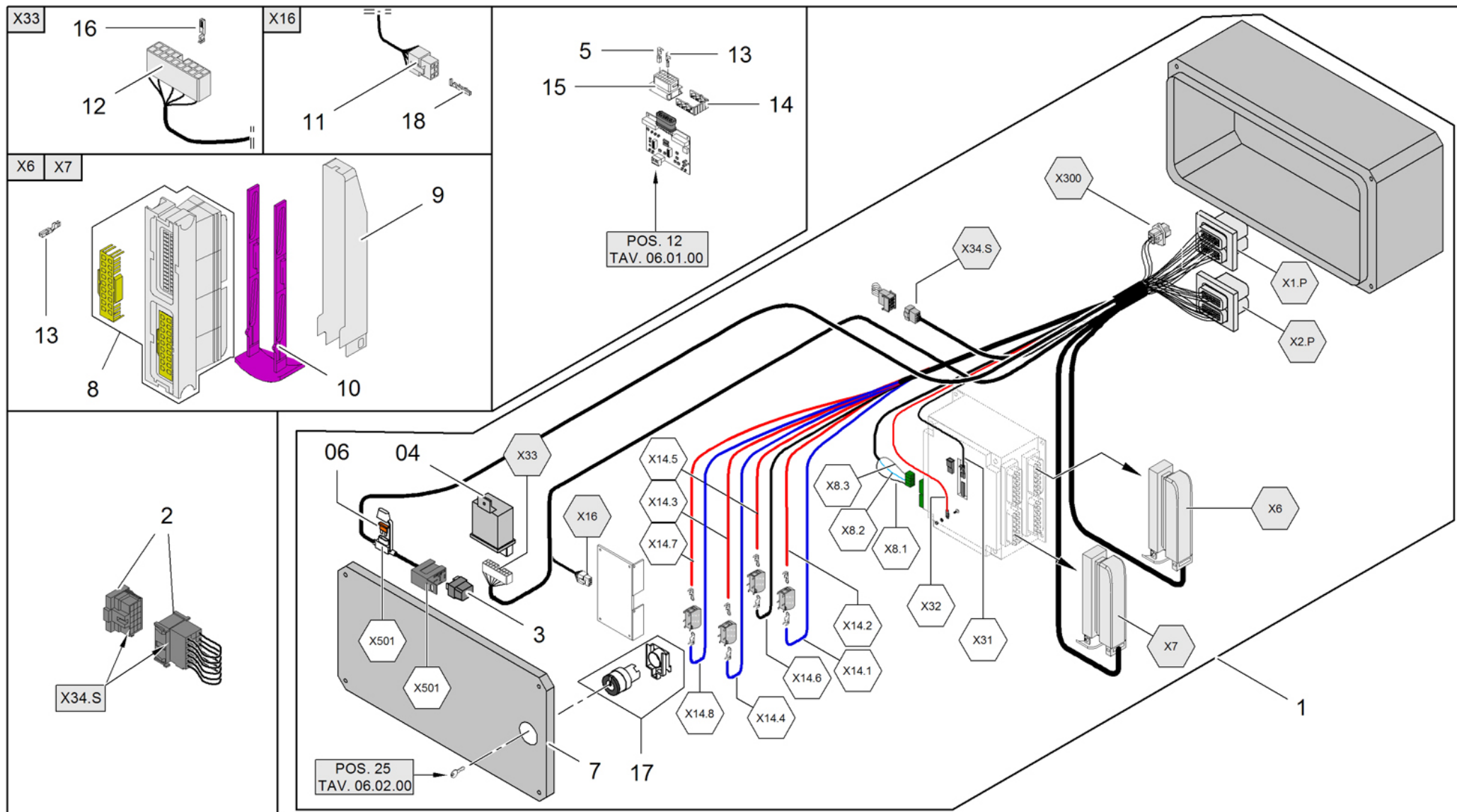

 IMPIANTO ELETTRICO  
 ELECTRICAL SYSTEM  
 INSTALLATION ÉLECTRIQUE





ELEKTRISCHE ANLAGE   
 INSTALACIÓN ELÉCTRICA 









**Main color codes:**  J1 - JLG Cream,  J2 - JLG Orange,  C4 - Green



 IMPIANTO ELETTRICO  
 ELECTRICAL SYSTEM  
 INSTALLATION ÉLECTRIQUE





ELEKTRISCHE ANLAGE   
 INSTALACIÓN ELÉCTRICA 



POS	Codice	 Descrizione	 Description	 Designation	 Benennung	 Descripción
1	1730720009	SCATOLA GENERALE IMPIANTO ELETTRICO COMPLETA DI CABLAGGIO, CONNETTORI E COPERCHIO	MAIN BOX ELECTRICAL WIRING COMPLETE WITH CONNECTORS AND COVER	BOITE	GEHÄUSE	CAJA
1	1764250003	SCATOLA GENERALE IMPIANTO ELETTRICO COMPLETA DI CABLAGGIO, CONNETTORI E COPERCHIO MK2 (DA C170000893)	MAIN BOX ELECTRICAL WIRING COMPLETE WITH CONNECTORS AND COVER MK2 (FROM C170000893)	BOÎTE	GEHÄUSE	CAJA
2	1730720012	CONNETTORE PONTE VERSIONE BENZINA	CONNECTOR BRIDGE VERSION PETROL	CONNECTEUR	VERBINDER	CONECTOR
2	1730720014	CONNETTORE PONTE VERSIONE DIESEL 10RPM (LL1775)	CONNECTOR BRIDGE VERSION DIESEL 10 (LL1775)	CONNECTEUR	VERBINDER	CONECTOR
2	1730720073	TERMINALE MASCHIO D.0,5-1 MM (X34)	TERMINAL MALE D.0 0.5 TO 1 MM (X34)	BORNE MALE D.0 0,5 A 1 MM (X34)	TERMINAL MALE D.0 0,5 BIS 1 MM (X34)	TERMINAL MACHO D.0 0,5 A 1 MM (X34)
2	1730720074	TERMINALE MASCHIO D.1,5-2,5 MM (X34)	TERMINAL MALE D.1 0.5 TO 2, 5 MM (X34)	BORNE MALE D.1 0,5 A 2, 5 MM (X34)	TERMINAL MALE D.1 0,5 BIS 2, 5 MM (X34)	TERMINAL MACHO D.1 0,5 A 2, 5 MM (X34)
2	1730720075	TERMINALE FEMMINA D 0,5-1 MM (X34)	TERMINAL FEMALE D 0.5-1 MM (X34)	BORNE FEMELLE D 0,5-1 MM (X34)	TERMINAL FEMALE D 0,5-1 MM (X34)	TERMINAL HEMBRA D 0.5-1 MM (X34)
2	1730720076	TERMINALE FEMMINA D 1,5-2,5 MM (X34)	TERMINAL FEMALE D 1.5-2.5 MM (X34)	BORNE FEMELLE D 1,5-2,5 MM (X34)	TERMINAL FEMALE D 1,5-2,5 MM (X34)	TERMINAL HEMBRA D 1.5 A 2.5 MM (X34)
2	1730720089	CONNETTORE PONTE VERSIONE LITIO 48V	CONNECTOR BRIDGE 48V LITHIUM VERSION	CONNEXION	CONNECTOR	CONECTOR



Main color codes:  J1 - JLG Cream,  J2 - JLG Orange,  C4 - Green



 IMPIANTO ELETTRICO  
 ELECTRICAL SYSTEM  
 INSTALLATION ÉLECTRIQUE





ELEKTRISCHE ANLAGE   
 INSTALACIÓN ELÉCTRICA 



POS	Codice	 Descrizione	 Description	 Designation	 Benennung	 Descripción
2	1776330001	CONNETTORE PONTE VERSIONE BENZINA MK2 (DA C170000893)	CONNECTOR BRIDGE VERSION PETROL MK2 (FROM C170000893)	CONNECTEUR	VERBINDER	CONECTADOR
3	1739150059	RELE' MICRO PER MONTAGGIO INTERNO SCATOLA 12V CON DIODO	MICRO RELAY 'FOR INTERNAL MOUNTING BOX WITH DIODE 12V	RELAIS MICRO POUR MONTAGE INTÉRIEUR BOÎTIER 12V AVEC DIODE	RELAIS MICROSCHALTER IM 12V KASTEN MIT DIODE	RELÉ MICRO PARA MONTAJE INTERNO CAJA 12V CON DIODO
4	1730720004	CENTRALINA 4 RELE' REGOLAZIONE RPM	RELAY BOX 4 'RPM ADJUSTMENT	BOÎTE RELAIS DE COMMANDE	RELAIS SCHACHTEL 4 RPM	CAJA RELÉ 4 RPM
5	17473800	PUNTALINO FEMMINA PER CONNETTORE 24 VIE SCHEDE CELLA DI CARICO D=2.8	FERRULE FEMALE CONNECTOR 24 WAY BOARD LOAD CELL D = 2.8	EMBOUT FEMELLE POUR CONNECTEUR 24 VOIES CARTE CELLULE DE CHARGE D=2.8	VERSCHRAUBUNG BUCHSE FÜR 24-WEGE-VERBINDER KORBLAST-PLATINE D=2,8	PUNTAL HEMBRA PARA CONECTOR 24 VÍAS CELULA DE CARGA D=2.8
6	05760800	FUSIBILE 7,5 A	FUSE 7,5 A	FUSIBLE 7,5 A	SICHERUNG 7,5 A	FUSIBLE 7,5 A
7	1730720010	COPERCHIO SCATOLA GENERALE IMPIANTO ELETTRICO	MAIN BOX ELECTRIC COVER	COUVERCLE	DECKEL	TAPA
8	17306000	PARTE DI CONNETTORE	CONNECTOR PART	CONNECTEUR	VERBINDER	CONECTADOR
9	17306100	COPERCHIO	COVER	COUVERCLE	DECKEL	TAPA
10	17306200	SLITTA	SLIDE	COULISSEAU	SCHLITTEN	CORREDERA
11	07503600	CONNETTORE PORTA FEMMINE 6 VIE PER MODEM	PORT CONNECTOR 6 WAY FEMALE FOR MODEM	CONNECTEUR PORTE-FEMELLES 6 VOIES POUR MODEM	VERBINDER	CONECTOR
12	1730720077	CONNETTORE 17 VIE M CENTRALINA RELE' RPM (X33)	CONNECTOR	CONNECTEUR	VERBINDER	CONECTADOR
13	17306300	PUNTALINO FEMMINA PER CONNETTORE 56 VIE SCHEDE MASTER D=1.5	FERRULE FEMALE CONNECTOR 56 WAY MAIN BOARD D = 1.5	BUTÉE FEMELLE CONNECTEUR 56 VOIES CARTE MASTER D = 1.5	AUFLAGESTIFT BUCHSE 56-WEGE-VERBINDER MASTERPLATINE D = 1.5	CONECTOR PUNTA HEMBRA 56 VÍAS TARJETA MASTER D=1,5



Main color codes:  J1 - JLG Cream,  J2 - JLG Orange,  C4 - Green

 IMPIANTO ELETTRICO  
 ELECTRICAL SYSTEM  
 INSTALLATION ÉLECTRIQUE



ELEKTRISCHE ANLAGE   
 INSTALACIÓN ELÉCTRICA 



POS	Codice	 Descrizione	 Description	 Designation	 Benennung	 Descripción
14	17473700	SLITTA PER CONNETTORE 24 VIE	SLIDE FOR 24-WAY CONNECTOR	COULISSEAU	SCHLITTEN	CORREDERA
15	17473600	PARTE DI CONNETTORE 24VIE	CONNECTOR PART 24 WAY	CONNECTEUR	VERBINGER	CONECTADOR
16	1730720078	CONTATTO FEMMINA (X33)	CONTACT FEMALE (X33)	CONTACT FEMELLE (X33)	CONTACT FEMALE (X33)	CONTACTO HEMBRA (X33)
17	1585570006	SELETORE	SELECTOR	SÉLECTEUR	WÄHLSCHALTER	SELECTOR
18	07503700	PUNTALINO FEMMINA PER CONNETTORE MODEM	CLAMP	BORNE	KLEMME	BORNE

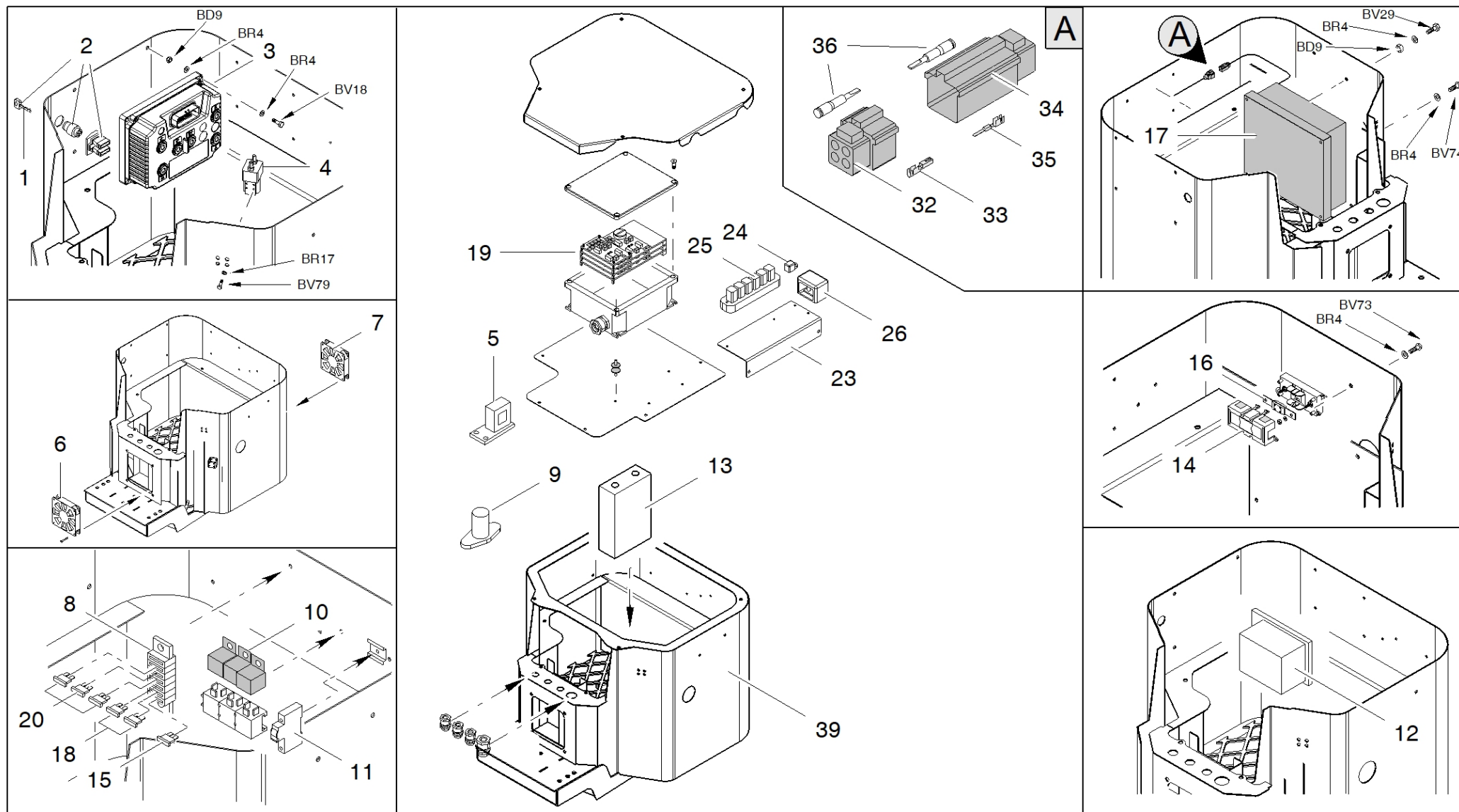

 COMPONENTI IMPIANTO ELETTRICO LITIO  
 ELECTRICAL SYSTEM COMPONENTS LITHIUM  
 COMPOSANTS INSTALLATION ÉLECTRIQUE LITHIUM





KOMPONENTEN ELEKTROANLAGE LITHIUM   
 COMPONENTES INSTALACIÓN ELÉCTRICA LITHIUM 





Main color codes:  J1 - JLG Cream,  J2 - JLG Orange,  C4 - Green



 COMPONENTI IMPIANTO ELETTRICO LITIO  
 ELECTRICAL SYSTEM COMPONENTS LITHIUM  
 COMPOSANTS INSTALLATION ÉLECTRIQUE LITHIUM



KOMPONENTEN ELEKTROANLAGE LITHIUM   
 COMPONENTES INSTALACIÓN ELÉCTRICA LITHIUM 

POS	Codice	 Descrizione	 Description	 Designation	 Benennung	 Descripción
2	1730720091	BLOCCHETTO CHIAVE COMPLETO DI CHIAVE PER PACCHI LITIO PERFORMANCE (PLUS)	KEY BLOCK COMPLETE WITH KEY FOR LITHIUM PERFORMANCE (PLUS)	BLOC CLÉ COMPLÈTE	KEY BLOCK COMPLETE	BLOQUE CLAVE COMPLETO
3	1677460003	INVERTER	INVERTER	INVERTER	INVERTER	INVERTER
4	26429300	TELERUTTORE	POWER SWITCH RELAY	TÉLÉRUPTEUR	FERNSCHALTER	TELERUPTOR
5	1735210002	TRASDUTTORE DI CORRENTE (DA C170000330)	CURRENT TRANSDUCER (FROM C170000330)	TRANSFORMATEUR D'INTENSITÉ (DA C170000330)	STROMMESSUMFORM ER (DA C170000330)	TRANSDUCTOR DE CORRIENTE ELÉCTRICA (DA C170000330)
6	1690690001	VENTOLA ANTERIORE	FRONT FAN	VENTILATEUR	LÜFTERRAD	VENTILADOR
7	1690690002	VENTOLA POSTERIORE	REAR FAN	VENTILATEUR	LÜFTERRAD	VENTILADOR
8	1690690003	BLOCCHETTO	FUSE HOLDERS BLOCK	BLOC	BLOCK	BLOQUE
8	1735210003	PUNTALINO PER CAVO SINGOLO SU FUSIBILE PACCO LITIO	CONNECTOR FOR FUSE ON SINGLE WIRE BATTERY PACK	CAPTEUR LEM	SENSOR LEM	SENSOR LEM
8	1735210004	PUNTALINO PER CAVO DOPPIO SU FUSIBILE PACCO LITIO	CONNECTOR FOR FUSE ON DOUBLE WIRE BATTERY PACK	CAPTEUR LEM	SENSOR LEM	SENSOR LEM
9	1690690020	TELERUTTORE	REMOTE-CONTROL SWITCH	TÉLÉRUPTEUR	FERNSCHALTER	TELERUPTOR
10	1690690005	RELÈ	RELAY	RELAIS	RELAIS	RELÉ
12	27032500	DC-DC IN36-72V OUT 12V16A VERSIONE LITHIUM CON TRATTAMENTO TRP	DC-DC IN36-72V OUT 12V16A LITHIUM VERSION WITH TRP TREATMENT	TRANSFORMATEUR	TRANSFORMATOR	TRANSFORMADOR



Main color codes:  J1 - JLG Cream,  J2 - JLG Orange,  C4 - Green







 COMPONENTI IMPIANTO ELETTRICO LITIO  
 ELECTRICAL SYSTEM COMPONENTS LITHIUM  
 COMPOSANTS INSTALLATION ÉLECTRIQUE LITHIUM





KOMPONENTEN ELEKTROANLAGE LITHIUM   
 COMPONENTES INSTALACIÓN ELÉCTRICA LITHIUM 



POS	Codice	 Descrizione	 Description	 Designation	 Benennung	 Descripción
13	1690690022	CELLA SINGOLA VERSIONE A	SINGLE CELL VERSION A	CELLULE UNIQUE A	EINZELZELLE A	UNICELULARES A
13	1742410001	CELLA LITIO VERSIONE B	LITHIUM CELL VERSION B	CELLULE LITHIUM UNIQUE B	LITHIUM EINZELZELLE B	CELDA BATERIA LITIO VERSION B
14	1690690009	COPERCHIO	COVER	COUVERCLE	DECKEL	TAPA
15	05760800	FUSIBILE 7,5 A	FUSE 7,5 A	FUSIBLE 7,5 A	SICHERUNG 7,5 A	FUSIBILE 7,5 A
16	1690690011	FUSIBILE 160A	FUSE 160A	FUSIBLE 160A	SICHERUNG 160A	FUSIBILE 160A
17	17193200	CARICABATTERIE LITIO 48V-230V COMPLETO DI CABLAGGIO	LITHIUM BATTERY CHARGER 48V-230V COMPLETE WITH WIRING	CHARGEUR DE BATTERIE	LADEGERÄT	CARGADOR DE BATERÍA
17	17193300	CARICABATTERIE LITIO 48V-110/120V COMPLETO DI CABLAGGIO	LITHIUM BATTERY CHARGER 48V- 110/120V COMPLETE WITH WIRING	CHARGEUR DE BATTERIE	LADEGERÄT	CARGADOR DE BATERÍA
18	05760600	FUSIBILE 3A	FUSE 3A	FUSIBLE 3A	SICHERUNG 3A	FUSIBILE 3A
19	1735210001	BMS 48V NUOVA VERSIONE (DA C170000330)	BMS 48V NEW VERSION (FROM C170000330)	BMS 48V	BMS 48V	BMS 48V
19	1737990002	CONTATTI A CRIMPARE C PER BMS	FERRULE CRIMP C FOR BMS	FERRULE	NUTMUTTER	ANILLO
19	1737990003	CONTATTI A CRIMPARE F PER BMS	FERRULE CRIMP F FOR BMS	FERRULE	NUTMUTTER	ANILLO
19	1737990004	HOUSING F CAN 4VIE PER BMS	HOUSING F CAN 4 WAY FOR BMS	LOGEMENT	GEHÄUSE	ALOJAMIENTO
19	1737990005	HOUSING F OPTO POWER 8VIE PER BMS	HOUSING F OPTO POWER 8 WAY FOR BMS	LOGEMENT	GEHÄUSE	ALOJAMIENTO
19	1737990006	HOUSING F VOLTAGE 20VIE PER BMS	HOUSING F VOLTAGE 20 WAY FOR BMS	LOGEMENT	GEHÄUSE	ALOJAMIENTO
19	1737990007	HOUSING C NO OPTO SIGNAL 18VIE PER BMS	HOUSING C NO OPTO SIGNAL 18 WAY FOR BMS	LOGEMENT	GEHÄUSE	ALOJAMIENTO



Main color codes:  J1 - JLG Cream,  J2 - JLG Orange,  C4 - Green



 COMPONENTI IMPIANTO ELETTRICO LITIO  
 ELECTRICAL SYSTEM COMPONENTS LITHIUM  
 COMPOSANTS INSTALLATION ÉLECTRIQUE LITHIUM





KOMPONENTEN ELEKTROANLAGE LITHIUM   
 COMPONENTES INSTALACIÓN ELÉCTRICA LITHIUM 

POS	Codice	 Descrizione	 Description	 Designation	 Benennung	 Descripción
19	1737990008	HOUSING C OPTO SIGNAL 14VIE FOR BMS	HOUSING C OPTO SIGNAL 14 WAY FOR BMS	LOGEMENT	GEHÄUSE	ALOJAMIENTO
19	1737990009	HOUSING C TEMPERATURE 16VIE FOR BMS	HOUSING C TEMPERATURE 16 WAY FOR BMS	LOGEMENT	GEHÄUSE	ALOJAMIENTO
20	05760900	FUSIBILE 10A	FUSE 10A	FUSIBLE 10A	SICHERUNG 10A	FUSIBLE 10A
23	073964Y1	PIASTRA	PLATE	PLATINE	PLATTE	PLACA
24	1730720086	TAPPO CONNETTORE 2 VIE	CONNECTOR PLUG 2 WAY	BOUCHON CONNECTEUR	VERSCHLUSS VERBINDER	TAPA CONECTOR
25	1730720087	CONNETTORE DERIVAZIONE CAN	JUNCTION CONNECTOR CAN	CONNECTEUR	VERBINDER	CONECTOR
26	1730720088	ISOLATORE CONNESSIONE MASSA	INSULATOR EARTH CONNECTION	ISOLATEUR	ISOLATOR	AISLADOR
32	1757250009	CONNETTORE PORTA FEMMINE 4 VIE MOLEX 220-110V 20- 25A	CONNECTOR	CONNECTEUR	VERBINDER	CONECTOR
33	1757250011	PUNTALINO	FERRULE	EMBOUT	ZWINGE	PUNTERA
34	1757250010	CONNETTORE PORTA MASCHI 4 VIE MOLEX 220-110V 20-25A	CONNECTOR	CONNECTEUR	VERBINDER	CONECTOR
35	1757250013	PUNTALINO MASCHIO PER CONNETTORE 4 VIE MOLEX 220-110V 20-25A	FERRULE	EMBOUT	ZWINGE	PUNTERA
36	1757250012	TAPPO PER CHIUSURA FORI SU CONNETTORE 4 VIE MOLEX 220-110V 20- 25A	CAP	BOUCHON	DECKEL	TAPA



Main color codes:  J1 - JLG Cream,  J2 - JLG Orange,  C4 - Green

 COMPONENTI IMPIANTO ELETTRICO LITIO  
 ELECTRICAL SYSTEM COMPONENTS LITHIUM  
 COMPOSANTS INSTALLATION ÉLECTRIQUE LITHIUM

KOMPONENTEN ELEKTROANLAGE LITHIUM   
 COMPONENTES INSTALACIÓN ELÉCTRICA LITHIUM 



POS	Codice	 Descrizione	 Description	 Designation	 Benennung	 Descripción
37	078574D1	CHIUSURA FORI FISSAGGIO PER LAMPEGGIANTE SU PACCO LITIO	CLOSING FIXING HOLES FOR FLASHING ON PACK LITHIUM	FERMETURE	SCHLUSS	CIERRE
38	1742410002	CABLAGGIO COMPLETO PACCO LITIO NUOVO BMS 48V (DA C170000330)	WIRING	CÂBLAGE	VERKABELUNG	CABLEADO
39	16851000	ASSIEME CARPENTERIA CASSONE LITHIUM UNIFICATO	STRUCTURAL BODY WITH LITHIUM UNIFIED	CHARPENTERIE	ZIMMERHANDWERK	CARPINTERIA





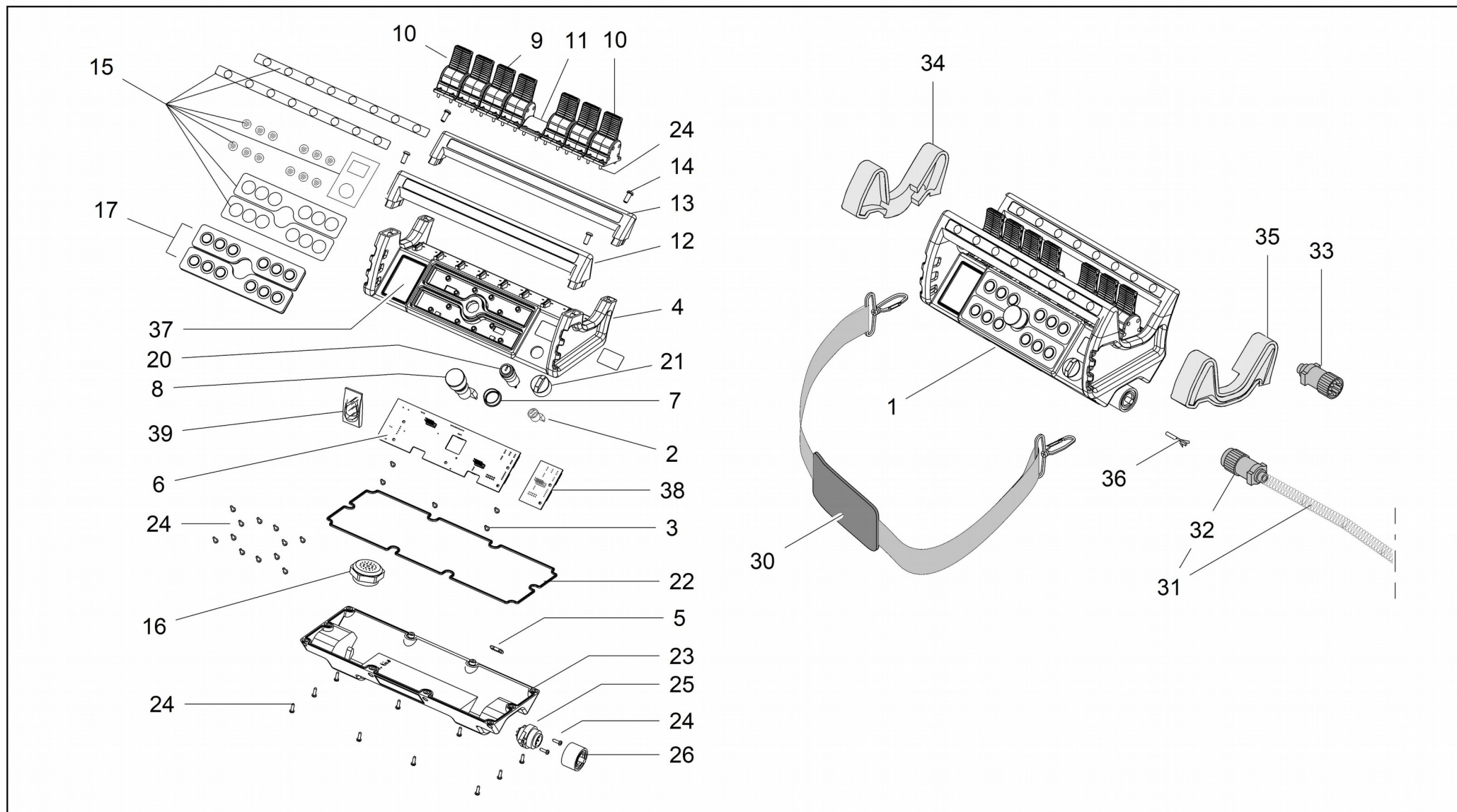

 TELECOMANDO  
 REMOTE CONTROL  
 TÉLÉCOMMANDE





FERNSTEUERUNG   
 TELECOMANDO 









Main color codes:  J1 - JLG Cream,  J2 - JLG Orange,  C4 - Green



 TELECOMANDO  
 REMOTE CONTROL  
 TÉLÉCOMMANDE

FERNSTEUERUNG   
 TELECOMANDO 



POS	Codice	 Descrizione	 Description	 Designation	 Benennung	 Descripción
1	27237400	TELECOMANDO CASE GRIGIO	REMOTE CONTROL GREY CASE	TÉLÉCOMMANDE	FERNSTEUERUNG	TELECOMANDO
2	07359400	CONTATTO PER STOP EMERGENZA TELECOMANDO 3S	CONTACT FOR EMERGENCY STOP REMOTE CONTROL 3S	CONTACTE POUR ARRET D'URGENCE	KONTAKT FÜR NOTSTOP	CONTACTO PARA PARADA DE EMERGENCIA
3	2646170003	VITI SCHEDA ELETTRONICA	ELECTRONIC BOARD SCREWS	VIS	SCHRAUBEN	TORNILLOS
4	2723740001	COPERCHIO SUPERIORE TELECOMANDO CASE GRIGIO + DISPLAY E PULSANTI (PER RICAMBIO È NECESSARIO IL SN DEL TELECOMANDO)	TOP COVER REMOTE CONTROL CASE GREY + DISPLAY AND BUTTONS (AS SPARE IS COMPULSORY THE SN OF REMOTE CONTROL)	COUVERCLE	DECKEL	TAPA
4	2723740002	COPERCHIO SUPERIORE TELECOMANDO CASE GRIGIO SOLO COPERCHIO, SENZA COMPONENTI E SENZA DISPLAY	TOP COVER REMOTE CONTROL CASE GREY ONLY CASE, WITHOUT COMPONENTS AND DISPLAY	COUVERCLE	DECKEL	TAPA
5	07359500	CONTATTO REED INTERNO TELECOMANDO 3S	REED CONTACT INTERNAL REMOTE 3S	REED CONTACT INTÉRIEUR 3S DISTANCE	REEDKONTAKT INDOOR REMOTE 3S	CONTACTO REED 3S REMOTO DE INTERIOR
6	2646170002	SCHEDA ELETTRONICA PER TELECOMANDO	ELECTRONIC BOARD FOR REMOTE CONTROL	FICHE ÉLECTRIQUE	ELEKTRONISCHE PLATINE	PLACA ELECTRÓNICA
7	2646170007	ANELLO	RING	BAGUE	RING	ANILLO
8	2646170008	PULSANTE EMERGENZA	EMERGENCY BUTTON	BOUTON D'URGENCE	NOTSTOP KNOPF	PULSADOR DE EMERGENCIA
9	17550700	KIT PROTEZIONE IN GOMMA PER JOYSTICK NERA	PROTECTION KIT	PROTECTION KIT	GUMMISCHUTZ KIT	PROTECCIÓN DE GOMA



Main color codes:  J1 - JLG Cream,  J2 - JLG Orange,  C4 - Green

 TELECOMANDO  
 REMOTE CONTROL  
 TÉLÉCOMMANDE





FERNSTEUERUNG   
 TELECOMANDO 

POS	Codice	 Descrizione	 Description	 Designation	 Benennung	 Descripción
9	2646170009	LEVA NERA	LEVER BLACK	LEVIER	HEBEL	PALANCA
10	17550800	KIT PROTEZIONE IN GOMMA PER JOYSTICK ROSSA	PROTECTION	PROTECTION	GUMMISCHUTZ	PROTECCION DE GOMA
10	2646170010	LEVA ROSSA	LEVER RED	LEVIER	HEBEL	PALANCA
12	2646170012	IMPUGNATURA SUPERIORE	GRIP UPPER PART	POIGNÉE	GRIFF	EMPUÑADURA
13	2646170013	IMPUGNATURA INFERIORE	GRIP LOWER PART	POIGNÉE	GRIFF	EMPUÑADURA
14	2646170014	VITE	SCREW	VIS	SCHRAUBE	TORNILLO
15	27005200	KIT ADESIVI	DECALS KIT	KIT AUTOCOLLANTS	AUFKLEBERSATZ	KIT PEGATINAS
16	2646170027	CICALINO COMPLETO DI SCHEDA ELETTRONICA TELECOMANDO	BEEPER FOR REMOTE CONTROL	BUZZER	SUMMER	ZUMBADOR COMPLETO DE TARJETA ELECTRÓNICA TELEMANDO
17	2646170017	PULSANTI	BUTTONS	BOUTONS	DRUCKKNÖPFE	BOTONES
20	2683930001	INTERRUTTORE	SWITCH	INTERRUPTEUR	SCHALTER	INTERRUPTOR
21	2683930002	CHIAVE ACCENSIONE	IGNITION KEY	CLÉ DE DÉMARRAGE	ZÜNDSCHLÜSSEL	LLAVE DE ENCENDIDO
22	2646170022	GUARNIZIONE	GASKET	JOINT	DICHTUNG	GUARNICIÓN
23	2646170023	COPERCHIO INFERIORE	COVER LOWER PART	COUVERCLE	DECKEL	TAPA
24	2646170024	VITE	SCREW	VIS	SCHRAUBE	TORNILLO
25	2646170025	CONNETTORE	CONNECTOR	CONNECTEUR	VERBINGER	CONECTOR
26	2646170026	COPERCHIO CONNETTORE	COVER CONNECTOR	COUVERCLE	DECKEL	TAPA
30	2646170030	CINGHIA	BELT	COURROIE	RIEMEN	CORREA
31	17235800	CAVO TELECOMANDO COMPLETO IIS /200	COMPLETE REMOTE CONTROL CABLE IIS / 200	CÂBLE COMPLET TÉLÉCOMMANDE IIS /200	FERNBEDIENUNGSKABEL KOMPLETT IIS / 200	CABLE TELECOMANDO COMPLETO IIS /200
32	2646170032	CONNETTORE COLLEGAMENTO TELECOMANDO	CONNECTOR FOR REMOTE CONTROL	CONNECTEUR	VERBINGER	CONECTOR



Main color codes:  J1 - JLG Cream,  J2 - JLG Orange,  C4 - Green



 TELECOMANDO  
 REMOTE CONTROL  
 TÉLÉCOMMANDE

FERNSTEUERUNG   
 TELECOMANDO 



POS	Codice	 Descrizione	 Description	 Designation	 Benennung	 Descripción
33	1684540001	DISPOSITIVO DI COMANDO PER ABILITAZIONE EMERGENZA A TERRA	CONTROL DEVICE FOR ACTIVATING THE EMERGENCY GROUND	DISPOSITIF DE COMMANDE EN CAS D'URGENCE	STEUERVORRICHTUNG IM NOTFALL	DISPOSITIVO DE CONTROL DE EMERGENCIA
34	07027200	PROTEZIONE DESTRA	RIGHT PROTECTION	PROTECTION DROITE	ABDECKUNG RECHTS	PROTECCIÓN DERECHA
35	07027100	PROTEZIONE SINISTRA	LEFT PROTECTION	PROTECTION GAUCHE	ABDECKUNG LINKS	PROTECCIÓN IZQUIERDA
36	27283000	PUNTALINO FEMMINA PER CONNETTORE TELECOMANDO	TERMINAL FEMALE CONNECTOR FOR REMOTE CONTROL	CONNECTEUR FEMELLE	VERBINDUNG	CONECTOR
37	07320200	SCHERMO LCD	DISPLAY	ÉCRAN	DISPLAY	PANTALLA
38	2646170006	SCHEDA DI TENSIONE TELECOMANDO	POWER BOARD FOR REMOTE CONTROL	CARTE	PLATINE	PLACA
39	2646170036	KIT CABLAGGIO INTERNO TELECOMANDO	INTERNAL CABLE KIT FOR REMOTE CONTROL	KIT CÂBLES TELECOMMANDE	SATZ KABEL FERNBEDIENUNG	KIT CABLES TELEMANDO





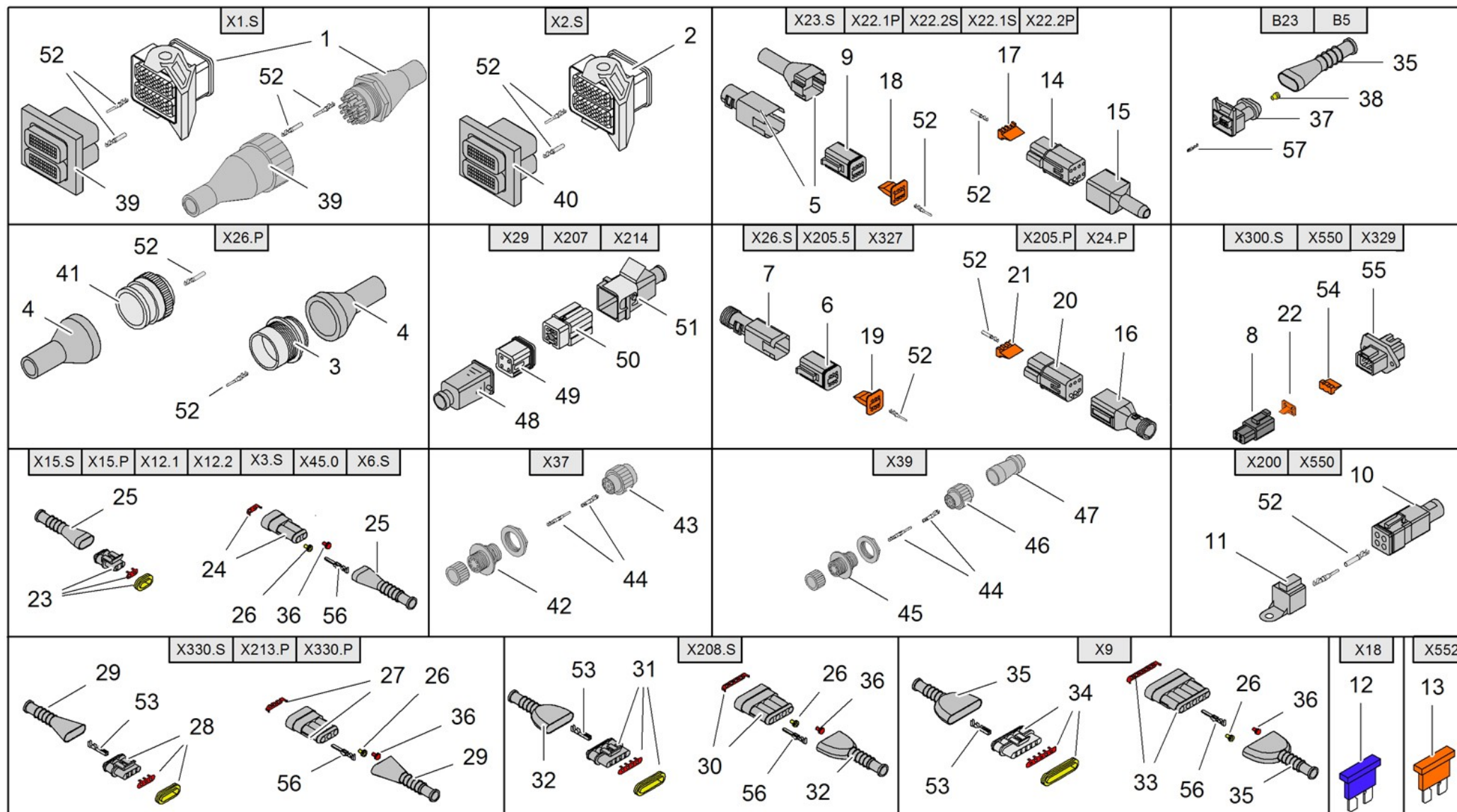

 IMPIANTO ELETTRICO  
 ELECTRICAL SYSTEM  
 INSTALLATION ÉLECTRIQUE





ELEKTRISCHE ANLAGE   
 INSTALACIÓN ELÉCTRICA 









Main color codes:  J1 - JLG Cream,  J2 - JLG Orange,  C4 - Green



 IMPIANTO ELETTRICO  
 ELECTRICAL SYSTEM  
 INSTALLATION ÉLECTRIQUE





ELEKTRISCHE ANLAGE   
 INSTALACIÓN ELÉCTRICA 



POS	Codice	 Descrizione	 Description	 Designation	 Benennung	 Descripción
1	1730720066	CONNETTORE	CONNECTOR	CONNECTEUR	VERBINDER	CONECTADOR
1	1764250004	CONNETTORE ROTONDO 47VIE PM (X1) MK2 (DA C170000893)	CONNECTOR 47 WAY ROUND PM (X1) MK2 (FROM C170000893)	CONNECTEUR MK2 (FROM C170000893)	VERBINDER MK2 (FROM C170000893)	CONECTADOR MK2 (FROM C170000893)
2	1730720067	CONNETTORE 64VIE PM (X2) POLAR "A"	CONNECTOR	CONNECTEUR	VERBINDER	CONECTADOR
3	1730720051	CONNETTORE 29 VIE M MOTORE (X26)	CONNECTOR	CONNECTEUR	VERBINDER	CONECTOR
4	1730720054	CAPPUCCIO POSTERIORE	CAP	CAPUCHON	KAPPE	CAPUCHO
5	1730720035	COVER POSTERIORE RIGIDA PER CONNETTORE 8 VIE MASCHIO	PROTECTION	PROTECTION	SCHUTZ	PROTECCION
5	1757250025	CAPPUCCIO POSTERIORE PER CONNETTORE MASCHIO	CAP	CAPUCHON	KAPPE	TAPA
6	1730720037	CONNETTORE 6 VIE MASCHIO	6-WAY MALE CONNECTOR	CONNECTEUR 6 VOIES MÂLE	6-WEGE-VERBINDER	CONECTOR 6 VÍAS
7	1730720039	COVER POSTERIORE RIGIDA PER CONNETTORE 6 VIE MASCHIO	PROTECTION	PROTECTION	SCHUTZ	PROTECCION
8	1757250028	CONNETTORE 4 VIE MASCHIO DEUTSCH PF POTENZA 25A	4-WAY MALE CONNECTOR 25A	CONNECTEUR 4 VOIES MÂLE 25A	4-WEGE-VERBINDER STIFT 25A	CONECTOR 4 VÍAS MACHO 25A
9	1730720033	CONNETTORE 8 VIE MASCHIO	8-WAY MALE CONNECTOR	CONNECTEUR 8 VOIES MÂLE	8-WEGE-VERBINDER STIFT	CONECTOR 8 VÍAS MACHO
10	1763330001	CONNETTORE 4 VIE MASCHIO DEUTSCH	4-WAY MALE CONNECTOR DEUTSCH	CONNECTEUR 4 VOIES MÂLE DEUTSCH	4-WEGE-VERBINDER STIFT DEUTSCH	CONECTOR 4 VÍAS MACHO DEUTSCH



Main color codes:  J1 - JLG Cream,  J2 - JLG Orange,  C4 - Green

 IMPIANTO ELETTRICO  
 ELECTRICAL SYSTEM  
 INSTALLATION ÉLECTRIQUE





ELEKTRISCHE ANLAGE   
 INSTALACIÓN ELÉCTRICA 



POS	Codice	 Descrizione	 Description	 Designation	 Benennung	 Descripción
11	1763330002	CAPPUCCIO FRONTALE CONNETTORE 4 VIE MASCHIO DEUTSCH	CAP FOR 4-WAY MALE CONNECTOR DEUTSCH	PAC CONNECTEUR 4 VOIES MÂLE DEUTSCH	CAP 4-WEGE-VERBINDER STIFT DEUTSCH	CAP CONECTOR 4 VÍAS MACHO DEUTSCH
12	07700700	FUSIBILE A LAMA 25A	FUSE 25A	FUSIBLE 25A	SICHERUNG 25A	FUSIBLE 25A
13	05760700	FUSIBILE A LAMA 5A	FUSE 5A	FUSIBLE 5A	SICHERUNG 5A	FUSIBLE 5A
14	1730720029	CONNETTORE 8 VIE FEMMINA	8-WAY FEMALE CONNECTOR	CONNECTEUR 8 VOIES FEMELLE	8-WEGE-VERBINDER BUCHSE	CONECTOR 8 VÍAS HEMBRA
15	1730720031	COVER POSTERIORE RIGIDA PER CONNETTORE 8 VIE FEMMINA	PROTECTION	PROTECTION	SCHUTZ	PROTECCION
15	1757250026	CAPPUCCIO POSTERIORE PER CONNETTORE FEMMINA	CAP	CAPUCHON	KAPPE	TAPA
16	1730720084	COVER POSTERIORE RIGIDA PER CONNETTORE 6 VIE FEMMINA	PROTECTION	PROTECTION	SCHUTZ	PROTECCION
16	1757250027	CAPPUCCIO POSTERIORE PER CONNETTORE 6 VIE FEMMINA	CAP	CAPUCHON	KAPPE	TAPA
17	1730720030	PIASTRINA DI BLOCCAGGIO CONNETTORE 8 VIE FEMMINA	PLATE	PLAQUE	PLATTE	PLACA
18	1730720034	PIASTRINA DI BLOCCAGGIO CONNETTORE 8 VIE MASCHIO	PLATE	PLAQUE	PLATTE	PLACA



Main color codes:  J1 - JLG Cream,  J2 - JLG Orange,  C4 - Green



 IMPIANTO ELETTRICO  
 ELECTRICAL SYSTEM  
 INSTALLATION ÉLECTRIQUE





ELEKTRISCHE ANLAGE   
 INSTALACIÓN ELÉCTRICA 



POS	Codice	 Descrizione	 Description	 Designation	 Benennung	 Descripción
19	1730720038	PIASTRINA DI BLOCCAGGIO CONNETTORE 6 VIE MASCHIO	PLATE	PLAQUE	PLATTE	PLACA
20	1730720041	CONNETTORE 6 VIE FEMMINA	6-WAY FEMALE CONNECTOR	CONNECTEUR 6 VOIES FEMELLE	6-WEGE-VERBINDER BUCHSE	CONECTOR 6 VÍAS HEMBRA
21	1730720042	PIASTRA BLOCCAGGIO CONNETTORE 6 VIE FEMMINA	CONNECTOR	CONNECTEUR	VERBINDER	CONECTADOR
22	1757250029	PIASTRINA DI BLOCCAGGIO CONNETTORE 4 VIE M POTENZA 25A	PLATE	PLAQUE	PLATTE	PLACA
23	1757250031	CONNETTORE SUPERSEAL PF 2 VIE	CONNECTOR	CONNECTEUR	VERBINDER	CONECTADOR
24	1757250032	CONNETTORE SUPERSEAL PM 2 VIE	CONNECTOR	CONNECTEUR	VERBINDER	CONECTADOR
25	1757250033	CAPPUCCIO POSTERIOERE CONNETTORE SUPERSEAL 2 VIE	CAP	CAPUCHON	KAPPE	CAPUCHO
26	1757250043	GOMMINO TENUTA PER CAVI CONNETTORI SUPERSEAL	RUBBER SEAL	JOINT EN CAOUTCHOUC	GUMMIDICHTUNG	JUNTA DE GOMA
27	1757250035	CONNETTORE SUPERSEAL PM 3 VIE	CONNECTOR	CONNECTEUR	VERBINDER	CONECTADOR
28	1757250034	CONNETTORE SUPERSEAL PF 3 VIE	CONNECTOR	CONNECTEUR	VERBINDER	CONECTADOR
29	1757250036	CAPPUCCIO POSTERIOERE CONNETTORE SUPERSEAL 3 VIE	CAP	CAPUCHON	KAPPE	CAPUCHO



Main color codes:  J1 - JLG Cream,  J2 - JLG Orange,  C4 - Green



 IMPIANTO ELETTRICO  
 ELECTRICAL SYSTEM  
 INSTALLATION ÉLECTRIQUE





ELEKTRISCHE ANLAGE   
 INSTALACIÓN ELÉCTRICA 



POS	Codice	 Descrizione	 Description	 Designation	 Benennung	 Descripción
30	1757250038	CONNETTORE SUPERSEAL PM 4 VIE	CONNECTOR	CONNECTEUR	VERBINDER	CONECTADOR
31	1757250037	CONNETTORE SUPERSEAL PF 4 VIE	CONNECTOR	CONNECTEUR	VERBINDER	CONECTADOR
32	1757250039	CAPPUCCIO POSTERIORE CONNETTORE SUPERSEAL 4 VIE	CAP	CAPUCHON	KAPPE	CAPUCHO
33	1757250041	CONNETTORE SUPERSEAL PM 5 VIE	CONNECTOR	CONNECTEUR	VERBINDER	CONECTADOR
34	1757250040	CONNETTORE SUPERSEAL PF 5 VIE	CONNECTOR	CONNECTEUR	VERBINDER	CONECTADOR
34	1757250056	CONNETTORE SUPERSEAL PF 6 VIE	CONNECTOR	CONNECTEUR	VERBINDER	CONECTADOR
34	1757250057	CAPPUCCIO POSTERIOERE CONNETTORE SUPERSEAL 6-7 VIE	CAP	CAPUCHON	KAPPE	CAPUCHO
35	1757250042	CAPPUCCIO POSTERIOERE CONNETTORE SUPERSEAL 5 VIE	CAP	CAPUCHON	KAPPE	CAPUCHO
36	1757250046	GOMMINO TENUTA TAPPO PER CONNETTORI SUPERSEAL	RUBBER SEAL	JOINT EN CAOUTCHOUC	GUMMIDICHTUNG	JUNTA DE GOMA
37	1757250044	CONNETTORE JPT 2 VIE PER ELETTROVALVOLE	CONNECTOR	CONNECTEUR	VERBINDER	CONECTADOR
38	1757250045	GOMMINO TENUTA PER CAVI CONNETTORI JPT	RUBBER SEAL	JOINT EN CAOUTCHOUC	GUMMIDICHTUNG	JUNTA DE GOMA
39	1730720064	CONNETTORE 50VIE PF (X1)	CONNECTOR 50 WAY PF (X1)	CONNECTEUR	VERBINDER	CONECTADOR



Main color codes:  J1 - JLG Cream,  J2 - JLG Orange,  C4 - Green



 IMPIANTO ELETTRICO  
 ELECTRICAL SYSTEM  
 INSTALLATION ÉLECTRIQUE





ELEKTRISCHE ANLAGE   
 INSTALACIÓN ELÉCTRICA 



POS	Codice	 Descrizione	 Description	 Designation	 Benennung	 Descripción
39	1764250006	CONNETTORE ROTONDO 47VIE PF (X1) MK2 (DA C170000893)	CONNECTOR 47 WAY ROUND PF (X1) MK2 (FROM C170000893)	CONNECTEUR MK2 (FROM C170000893)	VERBINDER MK2 (FROM C170000893)	CONECTADOR MK2 (FROM C170000893)
40	1730720065	CONNETTORE 64VIE PF (X2) POLAR A	CONNECTOR	CONNECTEUR	VERBINDER	CONECTADOR
41	1730720059	CONNETTORE 29 VIE F MOTORE (X26)	CONNECTOR	CONNECTEUR	VERBINDER	CONECTADOR
42	1730720019	CONNETTORE 19 VIE F SCATOLA CELLA (X37)	CONNECTOR 19 WAY FEMALE CELL BOX (X37)	CONNECTEUR	VERBINDER	CONECTADOR
43	1730720020	CONNETTORE 19 VIE M SCATOLA CELLA (X37)	CONNECTOR 19 WAY MALE CELL BOX (X37)	CONNECTEUR	AUFKLEBER	PEGATINA
44	1730720022	TERMINALE MASCHIO 16A (X37)	TERMINAL MALE 16A (X37)	BORNE	TERMINAL MALE	MALE TERMINAL
44	1730720023	TERMINALE FEMMINA 16A (X37)	TERMINAL FEMALE 16A (X37)	BORNE FEMELLE	TERMINAL FEMALE	TERMINAL HEMBRA
44	1730720025	TERMINALE F 0,25-0,50 MMQ (X39)	TERMINAL F 0.25-0.50 MMQ (X39)	TERMINAL	TERMINAL	TERMINAL
44	1730720027	TERMINALE M 0,25-0,50 MMQ (X39)	TERMINAL M 0.25-0.50 MMQ (X39)	TERMINAL	TERMINAL	TERMINAL
45	1730720024	CONNETTORE 12 VIE F SCATOLA CELLA	CONNECTOR 12 WAY FEMALE CELL BOX	CONNECTEUR	VERBINDER	CONECTADOR
46	1730720026	CONNETTORE 12 VIE M SCATOLA CELLA (X39)	CONNECTOR 12 WAY MALE BOX CELL (X39)	CONNECTEUR	VERBINDER	CONECTADOR
47	1730720028	FERMA CAVO CONNETTORE 12 VIE M SCATOLA CELLA (X39)	LOCK CABLE CONNECTOR 12 WAY MALE BOX CELL (X39)	ARRÊT CÂBLE	KABELHALTERUNG	PARADA DE CABLE



Main color codes:  J1 - JLG Cream,  J2 - JLG Orange,  C4 - Green



 IMPIANTO ELETTRICO  
 ELECTRICAL SYSTEM  
 INSTALLATION ÉLECTRIQUE





ELEKTRISCHE ANLAGE   
 INSTALACIÓN ELÉCTRICA 

POS	Codice	 Descrizione	 Description	 Designation	 Benennung	 Descripción
48	1730720083	CUSTODIA 3 POLI GRIGIA VOLANTE PER CONN.PM 4+1VIE 230/110V (X29)	HOUSING 3 POLE GREY FOR CONN. PM 4 + 1 WAY 230V / 110V (X29)	LOGEMENT	GEHÄUSE	ALOJAMIENTO
49	1730720082	FRUTTO CONN.PM 4+1VIE 230/110V (X29)	CONNECTOR PM 4 + 1 WAY 230V / 110V (X29)	CONNECTEUR	VERBINDER	CONECTADOR
50	1730720080	FRUTTO CONN. PF 4+1 VIA 230/110V (X29)	CONNECTOR PF 4 + 1 WAY 230V / 110V (X29)	CONNECTEUR	VERBINDER	CONECTADOR
51	1730720081	CUSTODIA 3 POLI GRIGIA CON GANCIO PER CONN. PF 4+1 VIA 230/110V (X29)	HOUSING 3 POLE GREY WITH HOOK FOR CONN. PF 4 + 1 ROUTE 230 / 110V (X29)	LOGEMENT	GEHÄUSE	ALOJAMIENTO
52	1730720032	TERMINALE MASCHIO CAVO 0.75-1.5	TERMINAL MALE CABLE 0.75-1.5	MALE TERMINAL	TERMINAL MALE	MALE TERMINAL
52	1730720036	TERMINALE FEMMINA CONNETTORE M CAVO 0.5-1	TERMINAL FEMALE MALE CONNECTOR CABLE 0.5-1	BORNE FEMELLE	TERMINAL FEMALE	TERMINAL HEMBRA
52	1730720040	TERMINALE FEMMINA (X24)	TERMINAL FEMALE (X24)	BORNE FEMELLE (X24)	TERMINAL FEMALE (X24)	TERMINAL HEMBRA (X24)
52	1730720043	TERMINALE MASCHIO (X24) DA 0.5 A 0.75	TERMINAL MALE (X24) DA 0.5 A 0.75	BORNE MALE (X24)	TERMINAL MALE (X24)	TERMINAL MACHO (X24)
52	1730720055	CONTATTO MASCHIO 25A CAVO 2.5-4	CONTACT MALE 25A CABLE 2.5-4	CONTACT MALE 25A	CONTACT MALE 25A	CONTACT MALE 25A
52	1730720056	TAPPO SIZE 12-16 (X26)	CAP SIZE 12-16 (X26)	CAP TAILLE 12-16 (X26)	CAP SIZE 12-16 (X26)	CAP TAMAÑO 12-16 (X26)
52	1730720057	TAPPO SIZE 16 (X26)	CAP SIZE 16 (X26)	PLUG SIZE 16 (X26)	PLUG SIZE 16 (X26)	MACHO TALLA 16 (X26)



Main color codes:  J1 - JLG Cream,  J2 - JLG Orange,  C4 - Green



 IMPIANTO ELETTRICO  
 ELECTRICAL SYSTEM  
 INSTALLATION ÉLECTRIQUE

ELEKTRISCHE ANLAGE   
 INSTALACIÓN ELÉCTRICA 



POS	Codice	 Descrizione	 Description	 Designation	 Benennung	 Descripción
52	1730720058	CONTATTO MASCHIO 7.5A (X26)	CONTACT PIN 7.5A (X26)	CONTACT PIN 7.5A (X26)	CONTACT PIN 7.5A (X26)	CONTACT 7.5A (X26)
52	1730720061	CONTATTO FEMMINA 7.5A (X26)	CONTACT FEMALE 7.5A (X26)	CONTACTER 7,5 FEMELLE (X26)	CONTACT FEMALE 7.5A (X26)	CONTACT 7.5A FEMENINO (X26)
52	1730720068	TAPPO SIZE 20 (X1)	CAP SIZE 20 (X1)	PLUG SIZE 20 (X1)	PLUG SIZE 20 (X1)	TAMAÑO DE ENCHUFE 20 (X1)
52	1730720069	CONTATTO FEMMINA 25A CONNETTORE M CAVO 2.5-4	CONTACT FEMALE 25A MALE CONNECTOR CABLE 2.5-4	CONTACT FEMELLE 25A	KONTAKT BUCHSE 25A	CONTACT HEMBRA 25A
53	1757250048	PUNTALINO FEMMINA PER SUPERSEAL	FERRULE FEMALE FOR SUPERSEAL	FERRULE	NUTMUTTER	ANILLO
54	1757250030	PIASTRINA DI BLOCCAGGIO CONNETTORE 4 VIE FEMMINA POTENZA 25A	PLATE	PLAQUE	PLATTE	PLACA
55	1757250018	CONNETTORE 4 VIE DEUTSCH A PARETE PM POTENZA 25A (X300)	CONNECTOR	CONNECTEUR	VERBINDER	CONECTADOR
56	1757250049	PUNTALINO MASCHIO PER SUPERSEAL	FERRULE MALE FOR SUPERSEAL	FERRULE	NUTMUTTER	ANILLO
57	1739150047	CONTATTO FEMMINA PER CONNETTORE JPT	CONTACT FEMALE FOR CONNECTOR JPT	CONTACT FEMELLE POUR CONNECTEUR JPT	KONTAKT BUCHSE FÜR JPT VERBINDER	CONTACTO HEMBRA PARA CONECTOR JPT





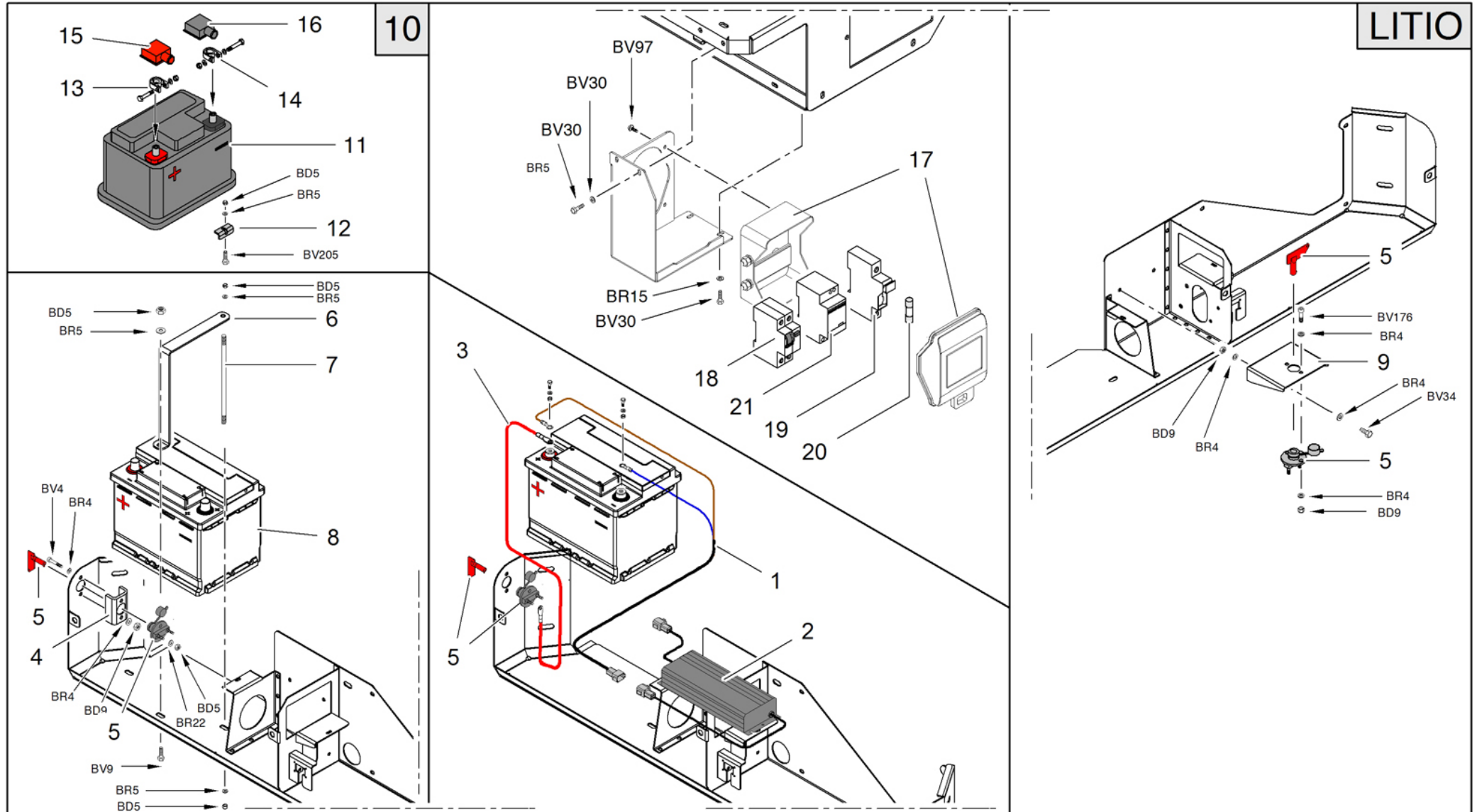

 IMPIANTO ELETTRICO  
 ELECTRICAL SYSTEM  
 INSTALLATION ÉLECTRIQUE





ELEKTRISCHE ANLAGE   
 INSTALACIÓN ELÉCTRICA 









Main color codes:  J1 - JLG Cream,  J2 - JLG Orange,  C4 - Green



 IMPIANTO ELETTRICO  
 ELECTRICAL SYSTEM  
 INSTALLATION ÉLECTRIQUE





ELEKTRISCHE ANLAGE   
 INSTALACIÓN ELÉCTRICA 



POS	Codice	 Descrizione	 Description	 Designation	 Benennung	 Descripción
1	1757260008	CABLAGGIO DA BATTERIA A CARICABATTERIA CON DIODO E CONNETTORE	WIRING FROM BATTERY TO CHARGER WITH DIODE AND CONNECTOR	CÂBLAGE	VERKABELUNG	CABLEADO
1	1764260002	LINEA DA ALIMENTATORE A BATTERIA COMPLETA DI CONNETTORI E DIODO	LINE FROM CHARGER TO BATTERY WITH CONNECTORS AND DIODE	LIGNE	LEITUNG	LÍNEA
2	1757250007	ALIMENTATORE ELETTRONICO 285W REGOLABILE IP65 PER BATTERIE 55-75 AH COMPLETO DI CONNETTORI	ELECTRONIC BALLAST	ALIMENTATEUR ÉLECTRONIQUE	ELEKTRONISCHES NETZGERÄT	ALIMENTADOR ELETRÓNICO
2	17572600081	CONNETTORE DEUTSCH 2 VIE COMPLETO DI DIODO CON PROTEZIONE	DEUTSCH CONNECTOR 2 WAYS OF COMPLETE WITH PROTECTION DIODE	CONNECTEUR	VERBINDER	CONECTOR
2	1764260003	DIODO IN LINEA P600 20A	DIODE ON 20A LINE	DIODE EN LIGNE 20A	DIODE IN LINIE 20A	DIODO EN LÍNEA 20A
3	1764260001	CAVO POSITIVO BATTERIA	12V BATTERY CABLE	CÂBLE	KABEL	CABLE
4	055687Y1	SUPPORTO	SUPPORT	SUPPORT	HALTERUNG	SOPORTE
5	04774900	STACCA BATTERIA	BATTERY CUT-OFF DEVICE	COUPE BATTERIE	BATTERIETRENNSCH ALTER	CORTA-BATERÍA
9	069226Y1	SUPPORTO	SUPPORT	SUPPORT	HALTERUNG	SOPORTE
10	17688300	KIT AGGIUNTA BATTERIA 27668600 SU LL1775-X17JP-X500AJ	BATTERY KIT	KIT BATTERIE	AKKUSATZ	KIT BATERIA
11	27668600	BATTERIA AGM S&S 12V 60AH 680A L02	BATTERY AGM S&S 12V 60AH 680A L02	BATTERIE AGM S&S 12V 60AH 680A L02	BATTERIE AGM S&S 12V 60AH 680A L02	BATERÍA AGM S&S 12V 60AH 680A L02



Main color codes:  J1 - JLG Cream,  J2 - JLG Orange,  C4 - Green



 IMPIANTO ELETTRICO  
 ELECTRICAL SYSTEM  
 INSTALLATION ÉLECTRIQUE





ELEKTRISCHE ANLAGE   
 INSTALACIÓN ELÉCTRICA 



POS	Codice	 Descrizione	 Description	 Designation	 Benennung	 Descripción
12	051705Y1	PIATTO FERMO BATTERIA	BATTERY BLOCK PLATE	PLACQUE D'ATTERT BATTERIE	BLOCKPLATTE BATTERIE	PLATO DE SUJECIÓN BATERÍA
13	06793100	MORSETTO POSITIVO BATTERIA CON RIDUTTORE	POSITIVE BATTERY TERMINAL	BORNE POSITIVE BATTERIE HS1100 AVEC RÉDUCTEUR	KLEMME PLUSPOL DER BATTERIE MIT REDUKTOR	BORNE POSITIVO BATERÍA HS1100 CON REDUCTOR
13	1739150023	MORSETTO POSITIVO A C PER BATTERIA M10	POSITIVE BATTERY CLAMP "C" M10	BORNE POSITIVE A C POUR BATTERIE M10	POSITIVE KLEMME FÜR BATTERIE M10	BORNE POSITIVO A C PARA BATERÍA M10
14	06793200	MORSETTO NEGATIVO BATTERIA CON RIDUTTORE	NEGATIVE BATTERY TERMINAL	BORNE NEGATIF BATTERIE AVEC RÉDUCTEUR	KLEMME MINUSPOL DER BATTERIE MIT REDUKTOR	BORNE NEGATIVO BATERÍA CON REDUCTOR
14	1739150025	MORSETTO NEGATIVO A C PER BATTERIA M10	NEGATIVE BATTERY TERMINAL C M10	BORNE NEGATIVE A C POUR BATTERIE M10	NEGATIVE KLEMME FÜR BATTERIE M10	BORNE NEGATIVO A C PARA BATERÍA M10
15	2632920007	COPRI POLI BATTERIA QUADRATO ROSSO	POLE BATTERY COVER RED SQUARE	POLE CACHE BATTERIE RED SQUARE	POLE BATTERY COVER RED SQUARE	TAPAS DE LA BATERIA
16	2632920008	COPRI POLI BATTERIA QUADRATO NERO	POLE BATTERY COVER BLACK SQUARE	POLE BATTERIE COUVERTURE CARRÉ NOIR	POLE BATTERY COVER BLACK SQUARE	TAPAS BATERIA
17	1730720006	SCATOLA ELETTRICA MAGNETOTERMICO FORATA CIAM	ELECTRICAL MAGNETOTHERMIC BOX DRILLED CIAM	BOÎTE ÉLECTRIQUE	ELEKTROGEHÄUSE	CAJA ELÉCTRICA
17	1757250008	SCATOLA ELETTRICO PLASTICA 6 MODULI BI COPERCHIO TRASPARENTE	ELECTRICAL BOX	BOÎTE ÉLECTRIQUE	SCHALTKASTEN	CAJA ELÉCTRICA
18	1556350015	INTERUTTORE AUTOMATICO MAGNETOTERMICO 220V	AUTOMATIC THERMAL SWITCH 220V	INTERRUPTEUR	INTERRUPTORES	INTERRUPTOR



Main color codes:  J1 - JLG Cream,  J2 - JLG Orange,  C4 - Green

 IMPIANTO ELETTRICO  
 ELECTRICAL SYSTEM  
 INSTALLATION ÉLECTRIQUE



ELEKTRISCHE ANLAGE   
 INSTALACIÓN ELÉCTRICA 



POS	Codice	 Descrizione	 Description	 Designation	 Benennung	 Descripción
18	1556350063	INTERUTTORE AUTOMATICO MAGNETOTERMICO 110-120V 25A (FINO A C170000355 MONTATO C16 SU MACCHINE 120V)	AUTOMATIC THERMAL SWITCH 110-120V 25A (UNTIL C170000355 MOUNTED C16 ON 120V MACHINES)	INTERRUPTEUR	SCHALTER	INTERRUPTOR
19	1730720015	PORTAFUSIBILE A TUBO 220/110V	FUSE HOLDER TUBE 220/110V	BOÎTE À FUSIBLES	SICHERUNGSKASTEN	PORTAFUSIBLES
20	1730720017	FUSIBILE A TUBO 10A	TUBE FUSE 10A	FUSIBLE	SICHERUNG	FUSIBLE
21	1757250006	TELERUTTORE 4POLI 63A CA/CC	RELAY	RELAIS	RELAIS	RELÉ

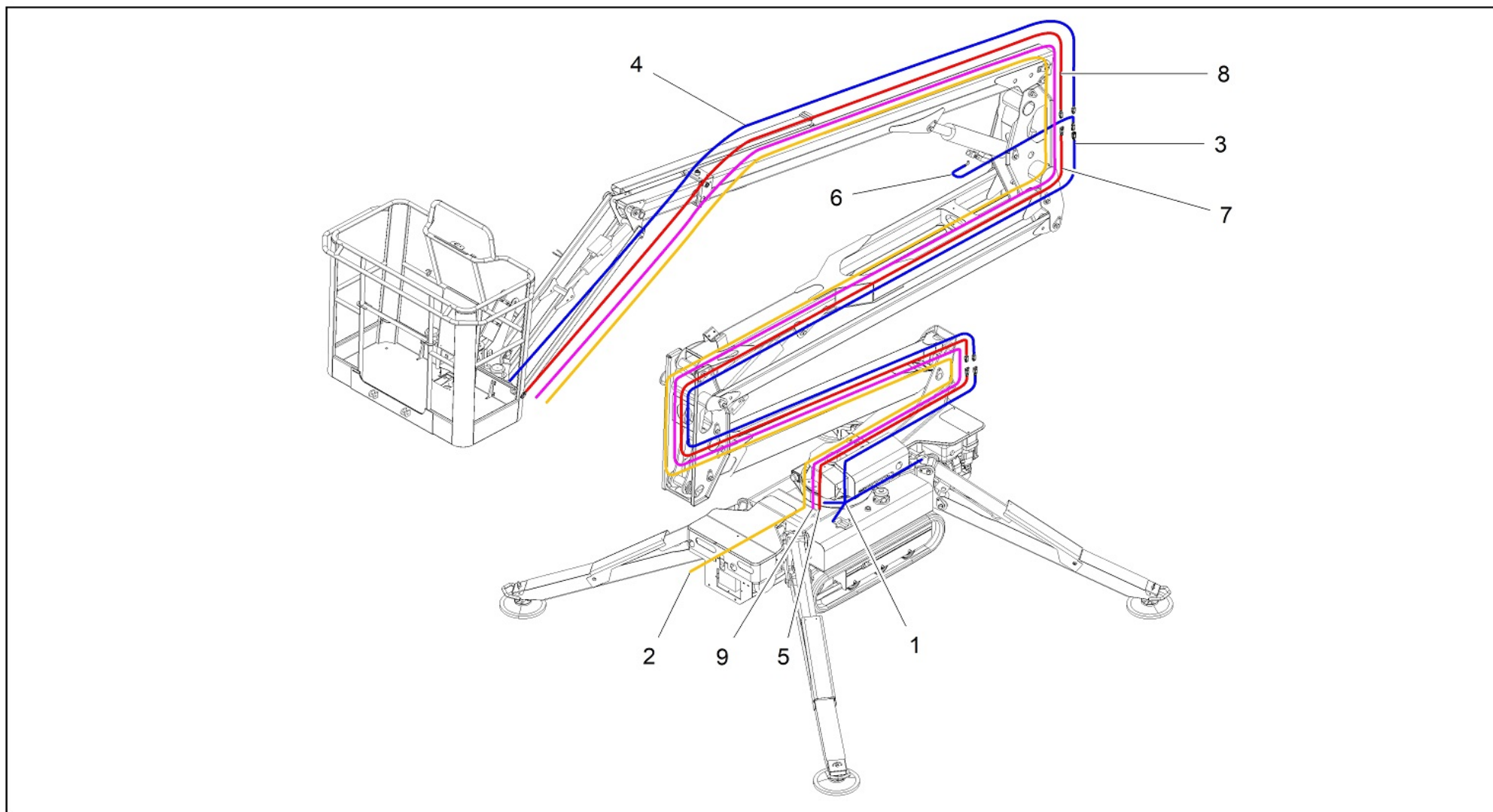

-  IMPIANTO ELETTRICO
-  ELECTRICAL SYSTEM
-  INSTALLATION ÉLECTRIQUE





- ELEKTRISCHE ANLAGE 
- INSTALACIÓN ELÉCTRICA 









Main color codes:  J1 - JLG Cream,  J2 - JLG Orange,  C4 - Green



 IMPIANTO ELETTRICO  
 ELECTRICAL SYSTEM  
 INSTALLATION ÉLECTRIQUE





ELEKTRISCHE ANLAGE   
 INSTALACIÓN ELÉCTRICA 



POS	Codice	 Descrizione	 Description	 Designation	 Benennung	 Descripción
1	17307200	KIT IMPIANTO GENERALE LL1775-X17JP-X500AJ-LL2010-X20JP-X600AJ (FINO A SN C170000892)	MAIN HARNESS KIT LL1775-X17JP-X500AJ-LL2010-X20JP-X600AJ (UNTIL SN C170000892)	KIT COMPOSANTS ÉLECTRIQUES	SATZ ELEKTRISCHE BAUTEILE	KIT COMPONENTES ELÉCTRICOS
1	17642500	KIT IMPIANTO GENERALE LL1775-X17JP-X500AJ-LL2010-X20JP-X600AJ (DA SN C170000893)	MAIN HARNESS KIT LL1775-X17JP-X500AJ-LL2010-X20JP-X600AJ (FROM SN C170000893)	KIT COMPOSANTS ÉLECTRIQUES	SATZ ELEKTRISCHER BAUTEILE	JUEGO COMPONENTES ELÉCTRICOS
3	1764290001	CAVO PROLUNGA 220-110V DA PRIMO BRACCIO A 3 BRACCIO (FINO A C170000892)	EXTENSION CABLE 220V-110V FROM 1 BOOM TO 3 BOOM (UNTIL SN C170000892)	CÂBLE	KABEL	CABLE
3	1764290004	CAVO PROLUNGA 7POLI DA 1 BRACCIO A 3 BRACCIO	EXTENSION CABLE 7WAY FROM 1 BOOM TO 3 BOOM	CÂBLE	KABEL	CABLE
4	1730720097	CABLAGGIO LINEA CESTO LL1775	BASKET WIRING LINE LL1775	CÂBLAGE	VERKABELUNG	CABLEADO
5	1764290002	CAVO PROLUNGA 220-110V DA BASE A PRIMO BRACCIO (FINO A C170000892)	EXTENSION CABLE 220V-110V FROM BASE TO 1 BOOM (UNTIL SN C170000892)	CÂBLE	KABEL	CABLE
5	1764290007	CAVO PROLUNGA 220-110V DA BASE A PRIMO BRACCIO LL1775-LL2010 CONNETTORI SOURIAU (DA C170000893)	EXTENSION CABLE 220-110V FROM BASE TO FIRST ARM LL1775-LL2010 SOURIAU CONNECTORS (FROM C170000893)	CÂBLE	KABEL	CABLE

Main color codes:  J1 - JLG Cream,  J2 - JLG Orange,  C4 - Green

 IMPIANTO ELETTRICO  
 ELECTRICAL SYSTEM  
 INSTALLATION ÉLECTRIQUE



ELEKTRISCHE ANLAGE   
 INSTALACIÓN ELÉCTRICA 



POS	Codice	 Descrizione	 Description	 Designation	 Benennung	 Descripción
6	1730720094	CAVO COMPLETO PER SENSORE DI POSIZIONE 3 CILINDRO BRACCIO	CABLE ASSEMBLY FOR POSITION SENSOR 3 BOOM CYLINDER	CÂBLE COMPLET POUR CAPTEUR DE POSITION 3° CYLINDRE BRAS	KABEL KOMPLETT FÜR POSITIONSSENSOR 3. AUSLEGERARM- ZYLINDER	CABLE COMPLETO PARA SENSOR DE POSICIÓN 3ERO CILINDRO BRAZO
6	1764290006	CAVO SENSORE CILINDRO 3 BRACCIO MK2 (DA C170000893)	CABLE CYLINDER SENSOR 3 BOOM MK2 (FROM C170000893)	CÂBLE	KABEL	CABLE
7	1764290008	CAVO PROLUNGA 220-110V DA PRIMO BRACCIO A TERZO BRACCIO LL1775- LL2010 CONNETTORI SOURIAU (DA C170000893)	EXTENSION CABLE 220-110V FROM FIRST ARM TO THIRD ARM LL1775-LL2010 SOURIAU CONNECTORS (FROM C170000893)	CÂBLE	KABEL	CABLE
8	1764290003	CAVO PROLUNGA 220-110V SFILO (FINO A C170000892)	EXTENSION CABLE 220V-110V EXTENSION BOOM (UNTIL SN C170000892)	CÂBLE	KABEL	CABLE
8	1764290009	CAVO PROLUNGA 220-110V SFILO LL1775 CONNETTORI SOURIAU (DA C170000893)	EXTENSION CABLE 220-110V LL1775 SOURIAU CONNECTORS (FROM C170000893)	CÂBLE	KABEL	CABLE
9	1730720008	CAVO 7 POLI LL1775/200 DA BASE A CESTO	7-POLE CABLE LL1775/200 FROM BASE TO BASKET	CABLE	KABEL	CABLE
9	17359200	CAVO ELETTRICO	ELECTRIC CABLE	CÂBLE ÉLECTRIQUE	ELEKTROKABEL	CABLE ELÉCTRICO

Main color codes:  J1 - JLG Cream,  J2 - JLG Orange,  C4 - Green













 ADESIVI  
 STICKER  
 AUTOCOLLANT





AUFKLEBER   
PEGATINA 



# DECALS LIST



Main color codes:  **J1** - JLG Cream,  **J2** - JLG Orange,  **C4** - Green



 ADESIVI  
 STICKER  
 AUTOCOLLANT





AUFKLEBER   
 PEGATINA 



POS	Codice	 Descrizione	 Description	 Designation	 Benennung	 Descripción
0	06039700	ADESIVO	STICKER	AUTOCOLLANT	AUFKLEBER	PEGATINA
0	06040300	ADESIVO	STICKER	AUTOCOLLANT	AUFKLEBER	PEGATINA
0	06040500	ADESIVO	STICKER	AUTOCOLLANT	AUFKLEBER	PEGATINA
0	06040900	ADESIVO	STICKER	AUTOCOLLANT	AUFKLEBER	PEGATINA
0	06041200	ADESIVO	STICKER	AUTOCOLLANT	AUFKLEBER	PEGATINA
0	06041300	ADESIVO	STICKER	AUTOCOLLANT	AUFKLEBER	PEGATINA
0	06041600	ADESIVO CARBURANTE BENZINA COLORE VERDE L=60 X 80 (**)	DECAL	AUTOCOLLANT	AUFKLEBER	PEGATINA
0	06042400	ADESIVO	STICKER	AUTOCOLLANT	AUFKLEBER	PEGATINA
0	06043900	ADESIVO	STICKER	AUTOCOLLANT	AUFKLEBER	PEGATINA
0	06044000	ADESIVO	STICKER	AUTOCOLLANT	AUFKLEBER	PEGATINA
0	06056300	ADESIVO	STICKER	AUTOCOLLANT	AUFKLEBER	PEGATINA
0	06060000	ADESIVO	STICKER	AUTOCOLLANT	AUFKLEBER	PEGATINA
0	06085900	ADESIVO	STICKER	AUTOCOLLANT	AUFKLEBER	PEGATINA
0	06086000	ADESIVO	STICKER	AUTOCOLLANT	AUFKLEBER	PEGATINA
0	06086700	ADESIVO	STICKER	AUTOCOLLANT	AUFKLEBER	PEGATINA
0	06136900	ADESIVO PUNTI INGRASSAGGIO Ø 55 TESTO NERO - SFONDO BIANCO (**)	STICKER GREASE POINTS Ø 55	AUTOCOLLANT POINTS GRAISSANGE Ø 55 TEXTE NOIR - FOND BLANC (**)	AUFKLEBER SCHMIERPUNKTE Ø 55, SCHWARZER TEXT - WEIßER UNTERGRUND	PEGATINS PUNTOS ENGRASE Ø 55 TEXTO NEGRO - FONDO BLANCO (**)
0	06164600	ADESIVO	STICKER	AUTOCOLLANT	AUFKLEBER	PEGATINA
0	06164700	ADESIVO	STICKER	AUTOCOLLANT	AUFKLEBER	PEGATINA
0	06165000	ADESIVO	STICKER	AUTOCOLLANT	AUFKLEBER	PEGATINA
0	06227200	ADESIVO "CONTROLLARE LIVELLO OLIO MOTORE " 7 LINGUE GIALLO L=82X108 (**)	DECAL	AUTOCOLLANT	AUFKLEBER	PEGATINA
0	06232100	ADESIVO	STICKER	AUTOCOLLANT	AUFKLEBER	PEGATINA



Main color codes:  J1 - JLG Cream,  J2 - JLG Orange,  C4 - Green



 ADESIVO  
 STICKER  
 AUTOCOLLANT





AUFKLEBER   
 PEGATINA 



POS	Codice	 Descrizione	 Description	 Designation	 Benennung	 Descripción
0	06254800	ADESIVO" STOP EMERGENZA" SFONDO GIALLO L=100X50 (**)	DECAL	AUTOCOLLANT	AUFKLEBER	PEGATINA
0	06436900	ADESIVO	DECAL	AUTOCOLLANT	AUFKLEBER	PEGATINA
0	06448100	ADESIVO	STICKER	AUTOCOLLANT	AUFKLEBER	PEGATINA
0	06448200	ADESIVO	STICKER	AUTOCOLLANT	AUFKLEBER	PEGATINA
0	06506400	ADESIVO	STICKER	AUTOCOLLANT	AUFKLEBER	PEGATINA
0	06520600	ADESIVO	STICKER	AUTOCOLLANT	AUFKLEBER	PEGATINA
0	06555500	ADESIVO	STICKER	AUTOCOLLANT	AUFKLEBER	PEGATINA
0	06555600	ADESIVO	STICKER	AUTOCOLLANT	AUFKLEBER	PEGATINA
0	06555700	ADESIVO	STICKER	AUTOCOLLANT	AUFKLEBER	PEGATINA
0	06555800	ADESIVO	STICKER	AUTOCOLLANT	AUFKLEBER	PEGATINA
0	06561200	ADESIVO	STICKER	AUTOCOLLANT	AUFKLEBER	PEGATINA
0	06706500	ADESIVO	STICKER	AUTOCOLLANT	AUFKLEBER	PEGATINA
0	06840400	ADESIVO	STICKER	AUTOCOLLANT	AUFKLEBER	PEGATINA
0	06924300	ADESIVO	STICKER	AUTOCOLLANT	AUFKLEBER	PEGATINA
0	06998800	ADESIVO	STICKER	AUTOCOLLANT	AUFKLEBER	PEGATINA
0	07034200	ADESIVO	STICKER	AUTOCOLLANT	AUFKLEBER	PEGATINA
0	07056400	ADESIVO	STICKER	AUTOCOLLANT	AUFKLEBER	PEGATINA
0	07056700	ADESIVO	STICKER	AUTOCOLLANT	AUFKLEBER	PEGATINA
0	07056800	ADESIVO	STICKER	AUTOCOLLANT	AUFKLEBER	PEGATINA
0	07058800	ADESIVO	STICKER	AUTOCOLLANT	AUFKLEBER	PEGATINA
0	07060500	ADESIVO	STICKER	AUTOCOLLANT	AUFKLEBER	PEGATINA
0	07060600	ADESIVO	STICKER	AUTOCOLLANT	AUFKLEBER	PEGATINA
0	07060700	ADESIVO	STICKER	AUTOCOLLANT	AUFKLEBER	PEGATINA
0	07071000	ADESIVO	STICKER	AUTOCOLLANT	AUFKLEBER	PEGATINA
0	07071200	ADESIVO	STICKER	AUTOCOLLANT	AUFKLEBER	PEGATINA
0	07198800	ADESIVO	STICKER	AUTOCOLLANT	AUFKLEBER	PEGATINA
0	07199100	ADESIVO	STICKER	AUTOCOLLANT	AUFKLEBER	PEGATINA
0	07240300	ADESIVO	STICKER	AUTOCOLLANT	AUFKLEBER	PEGATINA
0	07242000	ADESIVO	STICKER	AUTOCOLLANT	AUFKLEBER	PEGATINA
0	07242100	ADESIVO	STICKER	AUTOCOLLANT	AUFKLEBER	PEGATINA



Main color codes:  J1 - JLG Cream,  J2 - JLG Orange,  C4 - Green



 ADESIVI  
 STICKER  
 AUTOCOLLANT



AUFKLEBER   
 PEGATINA 



POS	Codice	 Descrizione	 Description	 Designation	 Benennung	 Descripció
0	07243000	ADESIVO	STICKER	AUTOCOLLANT	AUFKLEBER	PEGATINA
0	07264700	ADESIVO INDICATORE LED CARICABATTERIE 48V (Ø EST.31MM Ø INT.6 MM) VECCHIO BMS (FINO A C170000329)	DECAL	AUTOCOLLANT	AUFKLEBER	PEGATINA
0	07264800	ADESIVO	DECAL	AUTOCOLLANT	AUFKLEBER	PEGATINA
0	07268300	ADESIVO	DECAL	AUTOCOLLANT	AUFKLEBER	PEGATINA
0	07268400	ADESIVO	DECAL	AUTOCOLLANT	AUFKLEBER	PEGATINA
0	07281100	ADESIVO	DECAL	AUTOCOLLANT	AUFKLEBER	PEGATINA
0	07349200	ADESIVO	DECAL	AUTOCOLLANT	AUFKLEBER	PEGATINA
0	07350300	ADESIVO	DECAL	AUTOCOLLANT	AUFKLEBER	PEGATINA
0	07394800	ADESIVO INDICATORE LED CARICABATTERIE 48V (Ø EST.31MM Ø INT.6 MM) NUOVO BMS/4 (DA C170000330)	DECAL	AUTOCOLLANT	AUFKLEBER	PEGATINA
0	07397100	ADESIVO	DECAL	AUTOCOLLANT	AUFKLEBER	PEGATINA
0	07499300	ADESIVO DON'T OPEN THE CASE SFONDO GIALLO L=60X17 MM	DECAL	AUTOCOLLANT	AUFKLEBER	PEGATINA
0	07506500	ADESIVO JLG - EMERGENCY STOP L= 170X100 MM	DECAL	AUTOCOLLANT	AUFKLEBER	PEGATINA
0	07512700	ADESIVO ATTENZIONE! NON COLLEGARE IL COMPUTER L=75X75 MM	STICKER	AUTOCOLLANT	AUFKLEBER	PEGATINA
0	07668000	ADESIVO PERICOLO 110 VOLT 32A GIALLO	DECAL	AUTOCOLLANT	AUFKLEBER	PEGATINA



Main color codes:  J1 - JLG Cream,  J2 - JLG Orange,  C4 - Green



 ADESIVI  
 STICKER  
 AUTOCOLLANT





AUFKLEBER   
 PEGATINA 



POS	Codice	 Descrizione	 Description	 Designation	 Benennung	 Descripción
0	07668100	ADESIVO PULSANTI DISTRIBUTORE PARTE AEREA LL2614 L=318X52 MM	DECAL	AUTOCOLLANT	AUFKLEBER	PEGATINA
0	07668200	ADESIVO EMERGENCY STOP E BLOCCHETTO ACCENSIONE L=85X160 MM	DECAL	AUTOCOLLANT	AUFKLEBER	PEGATINA
0	07668300	ADESIVO	DECAL	AUTOCOLLANT	AUFKLEBER	PEGATINA
0	07690100	ADESIVO	DECAL	AUTOCOLLANT	AUFKLEBER	PEGATINA
0	07691500	ADESIVO	DECAL	AUTOCOLLANT	AUFKLEBER	PEGATINA
0	07802200	ADESIVO RUMORE 102 DB L=90X100 MM	STICKER NOISE 102 DB L = 90 X 100 MM	AUTOCOLLANT	AUFKLEBER	PEGATINA
0	07846600	ADESIVO	DECAL	AUTOCOLLANT	AUFKLEBER	PEGATINA
0	07878400	ADESIVO CASCO IMBRAGATURA E DIVIETI LL1370 L=175X118 MM	STICKER HELMET HARNES AND BANS	AUTOCOLLANT CASQUE HARNAIS ET INTERDICTION	STICKER HELMGURT UND VERBOTE	ETIQUETA ARNÉS CASCO Y PROHIBICIONES
0	08141300	ADESIVO	DECAL	AUTOCOLLANT	AUFKLEBER	PEGATINA
0	08318500	ADESIVO	DECAL	AUTOCOLLANT	AUFKLEBER	PEGATINA
0	08347400	STRISCIA BIANCA E ROSSA	DECAL	AUTOCOLLANT	AUFKLEBER	PEGATINA
0	08347500	STRISCIA BIANCA E ROSSA	DECAL	AUTOCOLLANT	AUFKLEBER	PEGATINA
0	1001125483	ADESIVO	STICKER	AUTOCOLLANT	AUFKLEBER	PEGATINA
0	1001223055	ADESIVO ISPEZIONE ANNUALE	DECAL YEARLY INSPECTION	INSPECTION ANNUELLE DES DÉCALQUES	AUFKLEBER JAHRESKONTROLLE	INSPECCIÓN ANUAL DE LA CALCOMANÍA
0	1001223453	ADESIVO NORMATIVA CANADESE ICES-002	CANADIAN REGULATIONS DECAL ICES-002	AUTOCOLLANT RÉGLEMENTAIRE CANADIEN ICES-002	KANADISCHE VORSCHRIFT AUFKLEBER	PEGATINA REGULATORIO CANADIENSE

Main color codes:  J1 - JLG Cream,  J2 - JLG Orange,  C4 - Green

 ADESIVO  
 STICKER  
 AUTOCOLLANT

AUFKLEBER   
 PEGATINA 

POS	Codice	 Descrizione	 Description	 Designation	 Benennung	 Descripcìon
0	1001228370	ADESIVO NORMATIVA CANADESE ICES-001	CANADIAN REGULATIONS DECAL ICES-001	AUTOCOLLANT RÉGLEMENTAIRE CANADIEN ICES-001	KANADISCHE VORSCHRIFTEN AUFKLEBER ICES-001	PEGATINA REGULATORIO CANADIENSE ICES- 001
0	1608710001	ADESIVO	STICKER	AUTOCOLLANT	AUFKLEBER	PEGATINA
0	1608710002	ADESIVO	STICKER	AUTOCOLLANT	AUFKLEBER	PEGATINA
0	1701499	ADESIVO	STICKER	AUTOCOLLANT	AUFKLEBER	PEGATINA
0	1701504	ADESIVO	STICKER	AUTOCOLLANT	AUFKLEBER	PEGATINA
0	1701505	ADESIVO	STICKER	AUTOCOLLANT	AUFKLEBER	PEGATINA
0	1701542	ADESIVO	STICKER	AUTOCOLLANT	AUFKLEBER	PEGATINA
0	1701640	ADESIVO	STICKER	AUTOCOLLANT	AUFKLEBER	PEGATINA
0	1701644	ADESIVO JLG CAVO CARICABATTERIA	STICKER JLG CABLE CHARGER	AUTOCOLLANT	AUFKLEBER	PEGATINA
0	1702155	ADESIVO	STICKER	AUTOCOLLANT	AUFKLEBER	PEGATINA
0	1703813	ADESIVO	STICKER	AUTOCOLLANT	AUFKLEBER	PEGATINA
0	1703814	ADESIVO	STICKER	AUTOCOLLANT	AUFKLEBER	PEGATINA
0	1704125	ADESIVO	DECAL	AUTOCOLLANT	AUFKLEBER	PEGATINA
0	1704277	ADESIVO	STICKER	AUTOCOLLANT	AUFKLEBER	PEGATINA
0	1705828	ADESIVO	STICKER	AUTOCOLLANT	AUFKLEBER	PEGATINA
0	1706098	ADESIVO	STICKER	AUTOCOLLANT	AUFKLEBER	PEGATINA
0	1706385	ADESIVO	STICKER	AUTOCOLLANT	AUFKLEBER	PEGATINA
0	1706493	ADESIVO	STICKER	AUTOCOLLANT	AUFKLEBER	PEGATINA
0	1706898	ADESIVO	STICKER	AUTOCOLLANT	AUFKLEBER	PEGATINA
0	1848760001	ADESIVO PER MACCHINE CON OLIO BIODEGRADABILE	STICKER FOR MACHINES WITH OIL BIODEGRADABLE	AUTOCOLLANT	AUFKLEBER	PEGATINA

Main color codes:  J1 - JLG Cream,  J2 - JLG Orange,  C4 - Green

# Cod. 17107300

**KIT INTEGRAZIONE ADESIVI PER PIATTAFORME AEREE LITHIUM-ANSI**  
*INTEGRATION KIT STICKERS PLATFORMS LITHIUM-ANSI*

**X370AJ • X390AJ • X430AJ • X500AJ • X550AJ • X600AJ • X700AJ • X770AJ**

**Da usare in aggiunta ai seguenti kit di sicurezza /**  
*To use in addition to the following safety kit*

**X370AJ .....cod.17788300**  
**X390AJ .....cod.17065200**  
**X430AJ.....cod.17788300**  
**X500AJ / MK2.....cod. 17776800**  
**X550AJ.....cod. 17065300**  
**X600AJ / MK2.....cod. 17777000**  
**X700AJ.....cod. 17065400**  
**X770AJ.....cod. 17633600**

**+ kit in lingua non inclusi nel codice generale / language code not included in the standard kit**

**+171073GB + 171073FR + 171073ES + 171073PT**





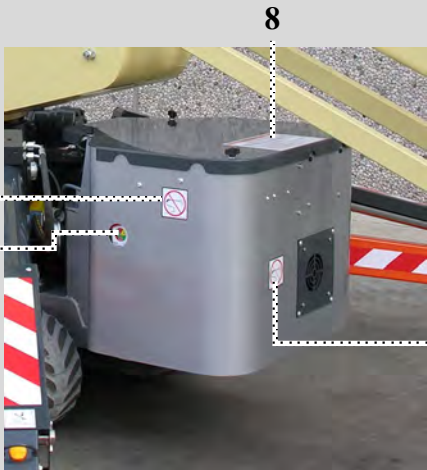

KIT ADESIVI - X390AJ

SET OF DECALS - X390AJ

KIT COLLANTS - X390AJ

AUFKLEBERSATZ - X390AJ

KIT ADHESIVOS - X390AJ

ADHESIEKIT - X390AJ

**cod. 17107300**

**Tav 01**

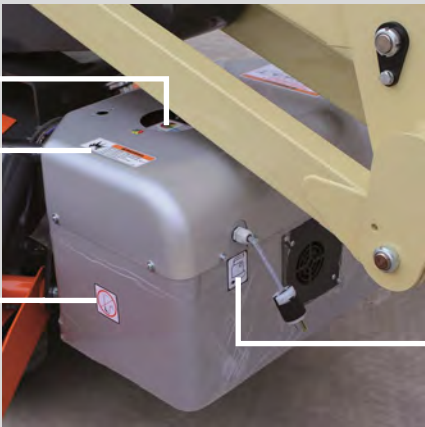

KIT ADESIVI - X370AJ / X430AJ

SET OF DECALS - X370AJ / X430AJ

KIT COLLANTS - X370AJ / X430AJ

AUFKLEBERSATZ - X370AJ / X430AJ

KIT ADHESIVOS - X370AJ / X430AJ

ADHESIEKIT - X370AJ / X430AJ

**cod. 17107300**

**Tav 01**



11

3

3

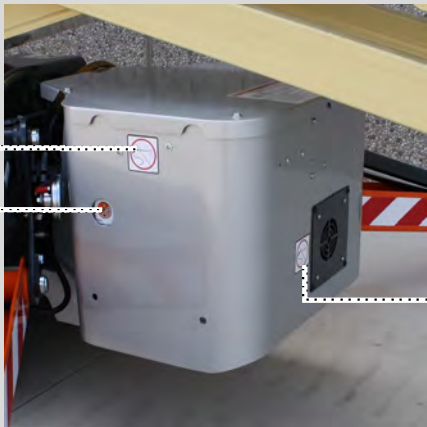

1

4



1

1

8

2

1



9



10

KIT ADESIVI - X500AJ

SET OF DECALS - X500AJ

KIT COLLANTS - X500AJ

AUFKLEBERSATZ - X500AJ

KIT ADHESIVOS - X500AJ

ADHESIEKIT - X500AJ

**cod. 17107300**

**Tav 01**



Sotto il coperchio /  
under the cover

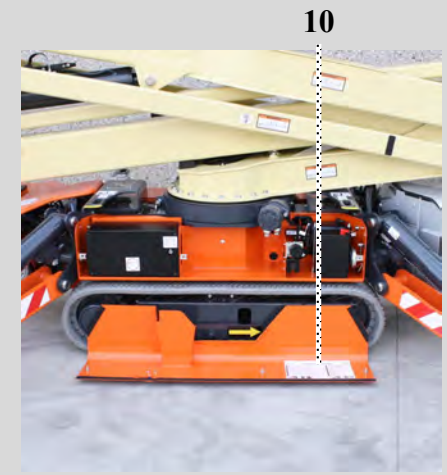

KIT ADESIVI - X600AJ

SET OF DECALS - X600AJ

KIT COLLANTS - X600AJ

AUFKLEBERSATZ - X600AJ

KIT ADHESIVOS - X600AJ

ADHESIEKIT - X600AJ

**cod. 17107300**

**Tav 01**



11



Sotto il coperchio /  
under the cover

3

3



8



2

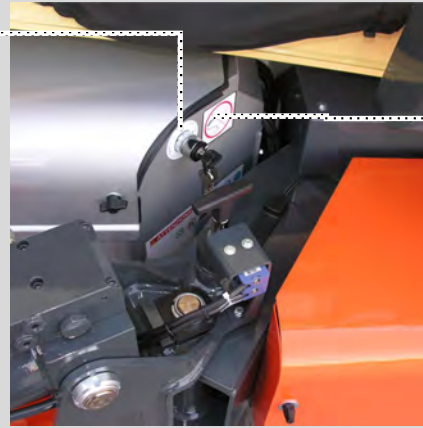

1

9

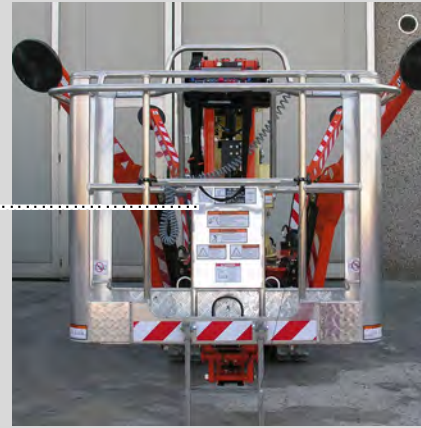

5 5 1

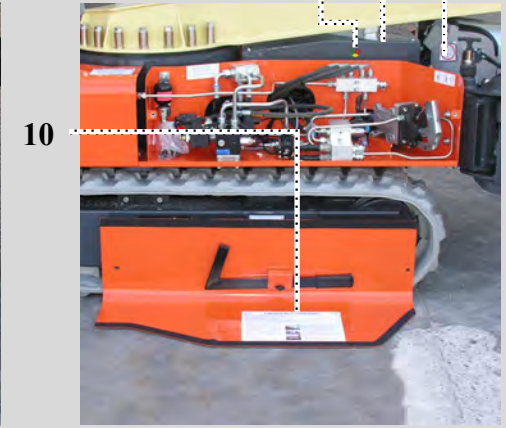

10

KIT ADESIVI - X700AJ

SET OF DECALS - X700AJ

KIT COLLANTS - X700AJ

AUFKLEBERSATZ - X700AJ

KIT ADHESIVOS - X700AJ

ADHESIEKIT - X700AJ

**cod. 17107300**

**Tav 01**



Sotto il coperchio /  
under the cover

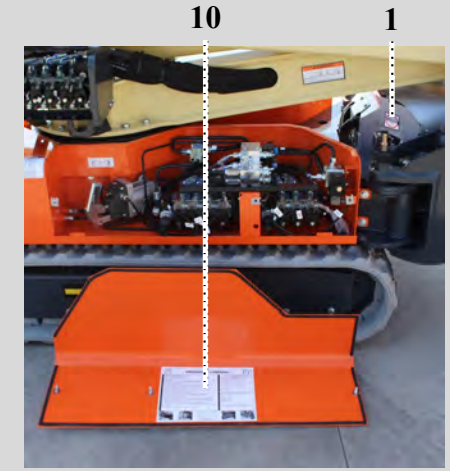
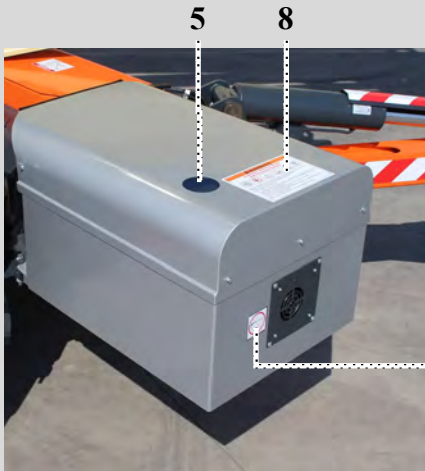

KIT ADESIVI - X770AJ

SET OF DECALS - X770AJ

KIT COLLANTS - X770AJ

AUFKLEBERSATZ - X770AJ

KIT ADHESIVOS - X770AJ

ADHESIEKIT - X770AJ

**cod. 17107300**

**Tav 01**

POS.	COD.	DESCRIZIONE / DESCRIPTION	Q.tà
01	1001125483	ADESIVO JLG VIETATO LAVARE L=63,5X63,5 MM	03
02	06506400	ADESIVO " CHIAVE DI ACCENSIONE" ESTERNO Ø 49 FORO Ø 22 SERIE LITHIUM ION <b>_MOD_B (**)</b>	01
03	06520600	ADESIVO RUMORE 88 dB L=90x100 MM <b>_MOD_B (**)</b>	02
04	07264700	ADESIVO INDICATORE LED CARICABATTERIE 48V (Ø EST.31MM Ø INT.6 MM) VECCHIO BMS (FINO A C170000329)	01
	07394800	ADESIVO INDICATORE LED CARICABATTERIE 48V (Ø EST.31MM Ø INT.6 MM) NUOVO BMS/4 (DA C170000330)	01
05	07264800	ADESIVO INDICATORE LED RICARICA BATTERIE Ø EST.21MM Ø INT.4 MM	02
06	1701644	ADESIVO JLG CAVO CARICABATTERIA L: 50,8X63,5 MM	01
07	1703813	ADESIVO JLG PERICOLO ESPLOSIONE BATTERIE - ING L=149,25X47,62 MM	01
08			
09			
10			
11	07194400	ADESIVO BOLLINO PER TELECOMANDO SERE IIIS COLORE GRIGIO Ø 10,50 MM	03
12			
13			
14			
15			
16			
17			
18			
19			
20			
21			





**AGGIORNATO IL / UPDATED 03/11/2017**

**Cod. 17187700**

**KIT INTEGRAZIONE ADESIVI PER PIATTAFORME AEREE LITHIUM-CE /  
*INTEGRATION KIT STICKERS PLATFORMS LITHIUM-CE***

**X14J - X17J - X19J - X23J**

**X13JPLUS - X15JPLUS - X17JPLUS - X20JPLUS - X26JPLUS**

**Da usare in aggiunta a / *To use in added to***

**X14J - cod.17063500**

**X14J-H - cod.17065000**

**X17J cod.17063700**

**X19J cod.17063200**

**X23J cod.17062700**

**X13JPLUS cod. 17788100**

**X15JPLUS cod. 17788100**

**X17JPLUS cod. 17242800**

**X20JPLUS cod. 17351800**

**X26JPLUS cod. 17633400**

**+ kit in lingua non inclusi nel codice generale + *language code not included in the standard kit***

**171877IT / 171877GB / 171877FR / 171877DE / 171877ES / 171877NL / 171877SW / 171877PT /  
171877DA / 171877NO / 171877RU / 171877PL / 171877SL / 171877FI / 171877CE / 171877JA**





KIT ADESIVI X14J LITHIUM

SET OF DECALS X14J LITHIUM

KIT COLLANTS X14J LITHIUM

AUFKLEBERSATZ X14J LITHIUM

KIT ADHESIVOS X14J LITHIUM

ADHESIEKIT X14J LITHIUM

**cod. 17187700**

**Tav 01**



9



8



1

4

3



6

1

1

2



7



3

KIT ADESIVI X17J LITHIUM

SET OF DECALS X17J LITHIUM

KIT COLLANTS X17J LITHIUM

AUFKLEBERSATZ X17J LITHIUM

KIT ADHESIVOS X17J LITHIUM

ADHESIEKIT X17J LITHIUM

**cod. 17187700**

**Tav 01**



9

3

3

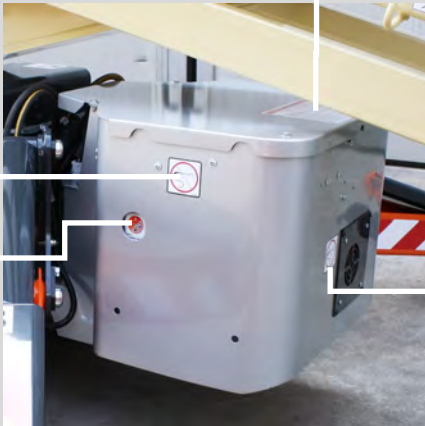

6

1

4



1

1

2



7



8

KIT ADESIVI X19J LITHIUM

SET OF DECALS X19J LITHIUM

KIT COLLANTS X19J LITHIUM

AUFKLEBERSATZ X19J LITHIUM

KIT ADHESIVOS X19J LITHIUM

ADHESIEKIT X19J LITHIUM

**cod. 17187700**

**Tav 01**

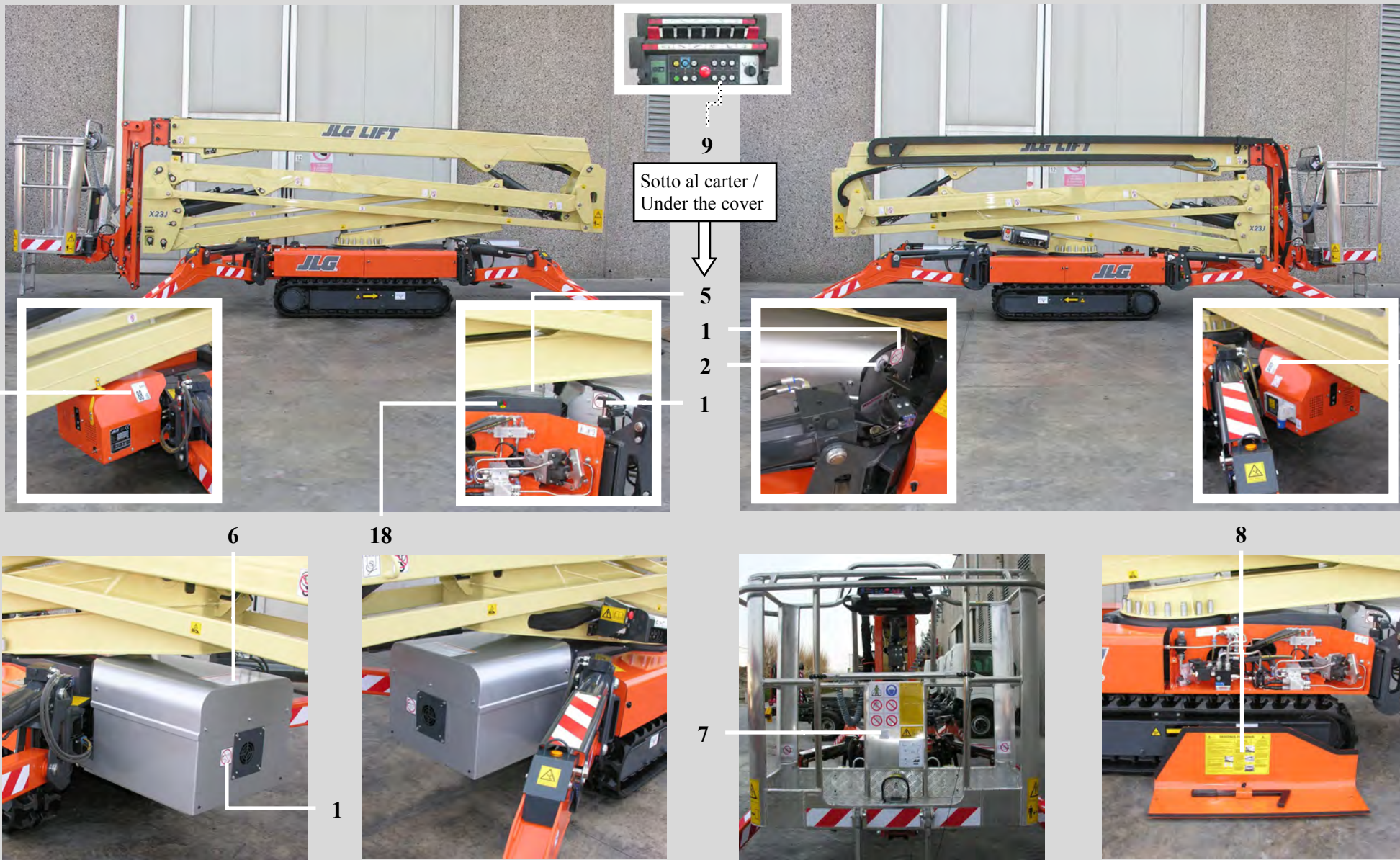

KIT ADESIVI X23J LITHIUM

SET OF DECALS X23J LITHIUM

KIT COLLANTS X23J LITHIUM

AUFKLEBERSATZ X23J LITHIUM

KIT ADHESIVOS X23J LITHIUM

ADHESIEKIT X23J LITHIUM

**cod. 17187700**

**Tav 01**



9



3

3



1

4



1

6

7

1



8

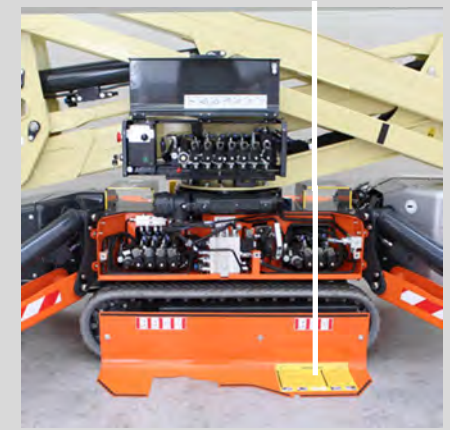

KIT ADESIVI - X13JPLUS LITHIUM	AUFKLEBERSATZ X - X13JPLUS LITHIUM	<b>cod. 17187700</b>
SET OF DECALS - X13JPLUS LITHIUM	KIT ADHESIVOS - X13JPLUS LITHIUM	
KIT COLLANTS - X13JPLUS LITHIUM	ADHESIEKIT - X13JPLUS LITHIUM	<b>Tav 01</b>



KIT ADESIVI - X15JPLUS LITHIUM  
 SET OF DECALS - X15JPLUS LITHIUM  
 KIT COLLANTS - X15JPLUS LITHIUM

AUFKLEBERSATZ X - X15JPLUS LITHIUM  
 KIT ADHESIVOS - X15JPLUS LITHIUM  
 ADHESIEKIT - X15JPLUS LITHIUM

**cod. 17187700**

**Tav 01**





9

3

3

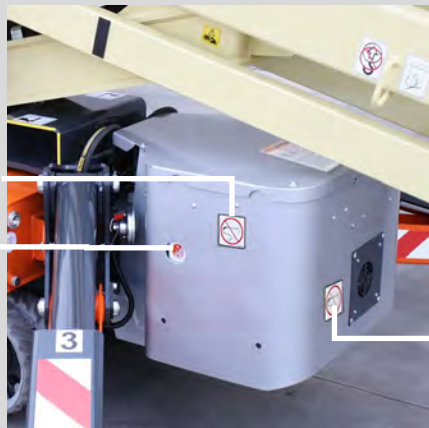

1

4

3

1



6

7

1



8

KIT ADESIVI X17JPLUS LITHIUM

SET OF DECALS X17JPLUS LITHIUM

KIT COLLANTS X17JPLUS LITHIUM

AUFKLEBERSATZ X17JPLUS LITHIUM

KIT ADHESIVOS X17JPLUS LITHIUM

ADHESIEKIT X17JPLUS LITHIUM

**cod. 17187700**

**Tav 01**



KIT ADESIVI X20JPLUS LITHIUM

SET OF DECALS X20JPLUS LITHIUM

KIT COLLANTS X20JPLUS LITHIUM

AUFKLEBERSATZ X20JPLUS LITHIUM

KIT ADHESIVOS X20JPLUS LITHIUM

ADHESIEKIT X20JPLUS LITHIUM

**cod. 17187700**

**Tav 01**

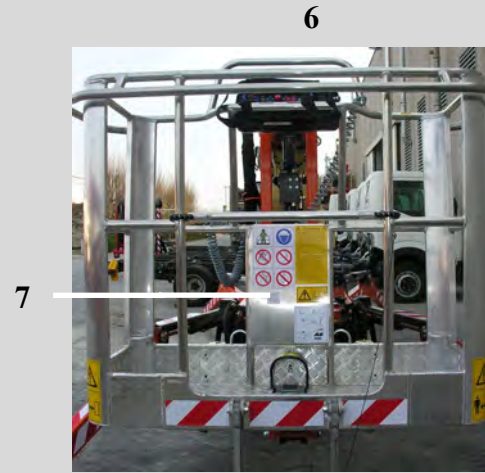
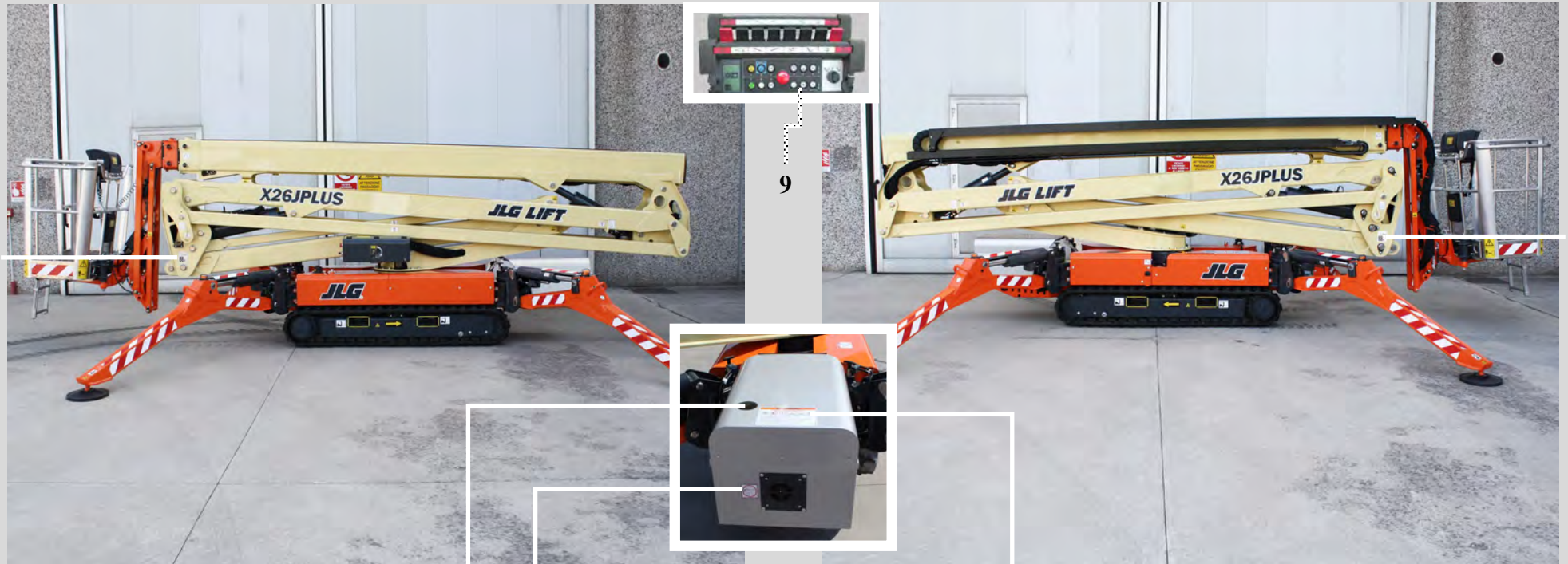

KIT ADESIVI X26JPLUS LITHIUM	AUFKLEBERSATZ X26JPLUS LITHIUM	<b>cod. 17187700</b>
SET OF DECALS X26JPLUS LITHIUM	KIT ADHESIVOS X26JPLUS LITHIUM	
KIT COLLANTS X26JPLUS LITHIUM	ADHESIEKIT X26JPLUS LITHIUM	<b>Tav 01</b>



**KIT LITHIUM SERIE JLG/CE COD. 171877\*\* POSIZIONE ADESIVI IN LINGUA / POSITION LANGUAGE STICKERS**

POS.	COD.	REV.	DESCRIZIONE / DESCRIPTION	Q.tà
	171877IT		KIT ADESIVI INTEGRAZIONE PIATTAFORME AEREE JLG/CE LITHIUM - LINGUA ITALIANO	
06	07188700	A	ADESIVO JLG ATTENZIONE PERICOLO BATTERIE - ITA L=210X145 MM	01
07	07188100	A	ADESIVO JLG RICARICARE LE BATTERIE DOPO L'USO O ALMENO OGNI 3 MESI L=50x50 MM – ITA	01
08 solo X17J	1705720001	A	ADESIVO ISTRUZIONI DISCESA DI EMERGENZA GL14703S LITHIUM ITALIANO L=290X175 MM (**)	01
08	<b>Per le / for X14J-X19J-X23J • X13JP-X15JP-X17JP-X20JP-X26JP</b> <b>Vedere discesa di emergenza motore termico / See emergency lowering heat engine</b>			
	171877GB		KIT ADESIVI INTEGRAZIONE PIATTAFORME AEREE JLG/CE LITHIUM - LINGUA INGLESE	
06	07201700	A	ADESIVO JLG ATTENZIONE PERICOLO BATTERIE - ING L=210X145 MM	01
07	07202100	A	ADESIVO JLG-CE RICARICARE LE BATTERIE DOPO L'USO ALMENO OGNI 3 MESI - ING L=50x50 MM	01
08 per X17J	1705720002	A	ADESIVO ISTRUZIONI DISCESA DI EMERGENZA GL14703S LITHIUM INGLESE L=290X175 MM	01
08	<b>Per le / for X14J-X19J-X23J • X13JP-X15JP-X17JP-X20JP-X26JP</b> <b>Vedere discesa di emergenza motore termico / See emergency lowering heat engine</b>			
	171877FR		KIT ADESIVI INTEGRAZIONE PIATTAFORME AEREE JLG/CE LITHIUM - LINGUA FRANCESE	
06	07201800	A	ADESIVO JLG ADESIVO ATTENZIONE PERICOLO BATTERIE - FRA L=210X145 MM	01
07	07202200	A	ADESIVO JLG RICARICARE LE BATTERIE DOPO L'USO ALMENO OGNI 3 MESI - FRA L=50x50 MM	01
08 per X17J	1705720003	A	ADESIVO ISTRUZIONI DISCESA DI EMERGENZA GL14703S LITHIUM FRANCESE L=290X175 MM (**)	01
08	<b>Per le / for X14J-X19J-X23J • X13JP-X15JP-X17JP-X20JP-X26JP</b> <b>Vedere discesa di emergenza motore termico / See emergency lowering heat engine</b>			

**KIT LITHIUM SERIE JLG/CE COD. 171877\*\* POSIZIONE ADESIVI IN LINGUA / POSITION LANGUAGE STICKERS**

POS.	COD.	REV.	DESCRIZIONE / DESCRIPTION	Q.tà
	171877DE		KIT ADESIVI INTEGRAZIONE PIATTAFORME AEREE JLG/CE LITHIUM - LINGUA TEDESCO	
06	07188800	A	ADESIVO JLG ATTENZIONE PERICOLO BATTERIE - TED L=210X145 MM	01
07	07188200	A	ADESIVO JLG RICARICARE LE BATTERIE DOPO L'USO O ALMENO OGNI 3 MESI L=50x50 MM –TED	01
08 per X17J	1705720004	A	ADESIVO ISTRUZIONI DISCESA DI EMERGENZA GL14703S LITHIUM TEDESCO L=290X175 MM (**)	01
08	<b>Per le / for X14J-X19J-X23J • X13JP-X15JP-X17JP-X20JP-X26JP</b> <b>Vedere discesa di emergenza motore termico / See emergency lowering heat engine</b>			
	171877ES		KIT ADESIVI INTEGRAZIONE PIATTAFORME AEREE JLG/CE LITHIUM - LINGUA SPAGNOLO	
06	07201900	A	ADESIVO JLG ATTENZIONE PERICOLO BATTERIE - SPA L=210X145 MM -	01
07	07202300	A	ADESIVO JLG RICARICARE LE BATTERIE DOPO L'USO ALMENO OGNI 3 MESI - SPA L=50x50 MM	01
08 per X17J	1705720005	A	ADESIVO ISTRUZIONI DISCESA DI EMERGENZA GL14703S LITHIUM SPAGNOLO L=290X175 MM (**)	01
08	<b>Per le / for X14J-X19J-X23J • X13JP-X15JP-X17JP-X20JP-X26JP</b> <b>Vedere discesa di emergenza motore termico / See emergency lowering heat engine</b>			
	171877NL		KIT ADESIVI INTEGRAZIONE PIATTAFORME AEREE JLG/CE LITHIUM - LINGUA OLANDESE	
06	07188900	A	ADESIVO JLG ATTENZIONE PERICOLO BATTERIE - OLA L=210X145 MM	01
07	07188300	A	ADESIVO JLG RICARICARE LE BATTERIE DOPO L'USO O ALMENO OGNI 3 MESI L=50x50 MM – OLA	01
08 per X17J	1705720006	A	ADESIVO ISTRUZIONI DISCESA DI EMERGENZA GL14703S LITHIUM OLANDESE L=290X175 MM (**)	01
08	<b>Per le / for X14J-X19J-X23J • X13JP-X15JP-X17JP-X20JP-X26JP</b> <b>Vedere discesa di emergenza motore termico / See emergency lowering heat engine</b>			

**KIT LITHIUM SERIE JLG/CE COD. 171877\*\* POSIZIONE ADESIVI IN LINGUA / POSITION LANGUAGE STICKERS**

POS.	COD.	REV.	DESCRIZIONE / DESCRIPTION	Q.tà
	171877SW		KIT ADESIVI INTEGRAZIONE PIATTAFORME AEREE JLG/CE LITHIUM - LINGUA SVEDESE	
06	07189000	A	ADESIVO JLG ATTENZIONE PERICOLO BATTERIE - SVE L=210X145 MM	01
07	07188400	A	ADESIVO JLG RICARICARE LE BATTERIE DOPO L'USO O ALMENO OGNI 3 MESI L=50x50 MM – SVE	01
08 per X17J	1705720010	A	ADESIVO ISTRUZ. DISCESA DI EMERGENZA GL14703S LITHIUM SVEDESE L=290X175 MM (**)	01
08	<b>Per le / for X14J-X19J-X23J • X13JP-X15JP-X17JP-X20JP-X26JP</b>			
	<b>Vedere discesa di emergenza motore termico / See emergency lowering heat engine</b>			
	171877PT		KIT ADESIVI INTEGRAZIONE PIATTAFORME AEREE JLG/CE LITHIUM - LINGUA PORTOGHESE	
06	07202000	A	ADESIVO JLG ATTENZIONE PERICOLO BATTERIE - POR L=210X145 MM	01
07	07202400	A	ADESIVO JLG RICARICARE LE BATTERIE DOPO L'USO O ALMENO OGNI 3 MESI L=50x50 MM – POR	01
08 per X17J	1705720007	A	ADESIVO ISTRUZ. DISCESA DI EMERGENZA GL14703S LITHIUM PORTOGHESE L=290X175 MM (**)	01
08	<b>Per le / for X14J-X19J-X23J • X13JP-X15JP-X17JP-X20JP-X26JP</b>			
	<b>Vedere discesa di emergenza motore termico / See emergency lowering heat engine</b>			
	171877DA		KIT ADESIVI INTEGRAZIONE PIATTAFORME AEREE JLG/CE LITHIUM - LINGUA DANESE	
06	07189100	A	ADESIVO JLG ATTENZIONE PERICOLO BATTERIE - DAN L=210X145 MM	01
07	07188500	A	ADESIVO JLG RICARICARE LE BATTERIE DOPO L'USO O ALMENO OGNI 3 MESI L=50x50 MM – DAN	01
08 per X17J	1705720011	A	ADESIVO ISTRUZ. DISCESA DI EMERGENZA GL14703S LITHIUM DANESE L=290X175 MM (**)	01
08	<b>Per le / for X14J-X19J-X23J • X13JP-X15JP-X17JP-X20JP-X26JP</b>			
	<b>Vedere discesa di emergenza motore termico / See emergency lowering heat engine</b>			

**KIT LITHIUM SERIE JLG/CE COD. 171877\*\* POSIZIONE ADESIVI IN LINGUA / POSITION LANGUAGE STICKERS**

POS.	COD.	REV.	DESCRIZIONE / DESCRIPTION	Q.tà
	171877NO		KIT ADESIVI INTEGRAZIONE PIATTAFORME AEREE JLG/CE LITHIUM - LINGUA NORVEGESE	
06	07189200	A	ADESIVO JLG ATTENZIONE PERICOLO BATTERIE - NOR L=210X145 MM	01
07	07188600	A	ADESIVO JLG RICARICARE LE BATTERIE DOPO L'USO O ALMENO OGNI 3 MESI L=50x50 MM – NOR	01
08 per X17J	1705720012	A	ADESIVO ISTRUZ. DISCESA DI EMERGENZA GL14703S LITHIUM NORVEGESE L=290X175 MM (**)	01
08	<b>Per le / for X14J - X17JPLUS - X19J - X20JPLUS - X23J - X26JPLUS</b> <b>Vedere discesa di emergenza motore termico / See emergency lowering heat engine</b>			
	171877RU		KIT ADESIVI INTEGRAZIONE PIATTAFORME AEREE JLG/CE LITHIUM - LINGUA RUSSO	
06	07920800	A	ADESIVO JLG ATTENZIONE PERICOLO BATTERIE - RUSSO L=210X145 MM	01
07	07910300	A	ADESIVO JLG RICARICARE LE BATTERIE DOPO L'USO O ALMENO OGNI 3 MESI L=50x50 MM – RUS	01
08 per X17J	/		/	/
08	<b>Per le / for X14J - X17JPLUS - X19J - X20JPLUS - X23J - X26JPLUS</b> <b>Vedere discesa di emergenza motore termico / See emergency lowering heat engine</b>			
	171877PL		KIT ADESIVI INTEGRAZIONE PIATTAFORME AEREE JLG/CE LITHIUM - LINGUA POLACCO	
06	07508000	A	ADESIVO JLG-ANSI ATTENZIONE PERICOLO BATTERIE - POLACCO L=210X145 MM	01
07	07508100	A	ADESIVO JLG-CE RICARICARE LE BATTERIE DOPO L'USO - POLACCO L=50x50 MM	01
08 per X17J	/		/	/
08	<b>Per le / for X14J - X17JPLUS - X19J - X20JPLUS - X23J - X26JPLUS</b> <b>Vedere discesa di emergenza motore termico / See emergency lowering heat engine</b>			



**KIT LITHIUM SERIE JLG/CE COD. 171877\*\* POSIZIONE ADESIVI IN LINGUA / POSITION LANGUAGE STICKERS**

POS.	COD.	REV.	DESCRIZIONE / DESCRIPTION	Q.tà
	171877SL		KIT ADESIVI INTEGRAZIONE PIATTAFORME AEREE JLG/CE LITHIUM - LINGUA SLOVENO	
06	07920900	A	ADESIVO JLG / CE ATTENZIONE PERICOLO BATTERIE - SLOVENO L=210X145 MM	01
07	07910500	A	ADESIVO JLG RICARICARE LE BATTERIE DOPO L'USO O ALMENO OGNI 3 MESI L=50x50 MM – SLO	01
08 per X17J	/	/	/	/
08	<b>Per le / for X14J - X17JPLUS - X19J - X20JPLUS - X23J - X26JPLUS</b> <b>Vedere discesa di emergenza motore termico / See emergency lowering heat engine</b>			
	171877FI		KIT ADESIVI INTEGRAZIONE PIATTAFORME AEREE JLG/CE LITHIUM - LINGUA FINLANDESE	
06	07921000	A	ADESIVO JLG / CE ATTENZIONE PERICOLO BATTERIE - FINLANDESE L=210X145 MM	01
07	07910600	A	ADESIVO JLG RICAR. LE BATTERIE DOPO L'USO O ALMENO OGNI 3 MESI L=50x50 MM – FINLANDE	01
08 per X17J	/	/	/	/
08	<b>Per le / for X14J - X17JPLUS - X19J - X20JPLUS - X23J - X26JPLUS</b> <b>Vedere discesa di emergenza motore termico / See emergency lowering heat engine</b>			
	171877CE		KIT ADESIVI INTEGRAZIONE PIATTAFORME AEREE JLG/CE LITHIUM - LINGUA CECO	
06	07921100	A	ADESIVO JLG-CE ATTENZIONE PERICOLO BATTERIE - CECO L=210X145 MM	01
07	07910700	A	ADESIVO JLG-CE RICARICARE LE BATTERIE DOPO L'USO ALMENO OGNI 3 MESI - JAPAN L=50x50 MM	01
08 per X17J	/		/	/
08	<b>Per le / for X14J - X17JPLUS - X19J - X20JPLUS - X23J - X26JPLUS</b> <b>Vedere discesa di emergenza motore termico / See emergency lowering heat engine</b>			
	171877JA		KIT ADESIVI INTEGRAZIONE PIATTAFORME AEREE JLG/CE LITHIUM - LINGUA GIAPPONESE	
06	07341100	A	ADESIVO JLG - CE ATTENZIONE PERICOLO BATTERIE - JAPAN L=210X145 MM	01
07	07341200	A	ADESIVO JLG-CE RICARICARE LE BATTERIE DOPO L'USO - JAPAN L=50x50 MM	01
08 per X17J	/		/	/
08	<b>Per le / for X14J - X17JPLUS - X19J - X20JPLUS - X23J - X26JPLUS</b> <b>Vedere discesa di emergenza motore termico / See emergency lowering heat engine</b>			



**Cod. 17224100**

**KIT ADESIVI SICUREZZA PIATTAFORMA AEREA /  
AERIAL PLATFORM KIT STICKERS SAFETY**

**JLG/ANSI - X500AJ**

**+ kit in lingua non inclusi nel codice generale**

**+ language code not included in the standard kit**

**172241GB**

**172241FR**

**172241ES**

**172241PT**

**DA USARE CON / FOR USE WITH**

- **17224200 KIT ADESIVI COMMERCIALI PIATTAFORMA AEREA X500AJ ANSI /  
STICKERS KIT COMMERCIAL AERIAL PLATFORM**
- **17107300 KIT ADESIVI INTEGRZIONE PER PIATTAFORME AEREE JLG-ANSI LITHIUM /  
STICKER KITS FOR INTEGRATION PLATFORMS JLG-ANSI LITHIUM /  
X390AJ - X500AJ - X550AJ - X600AJ - X700AJ - X770AJ**
- **171073\*\* KIT IN LINGUA / KIT IN LANGUAGE**



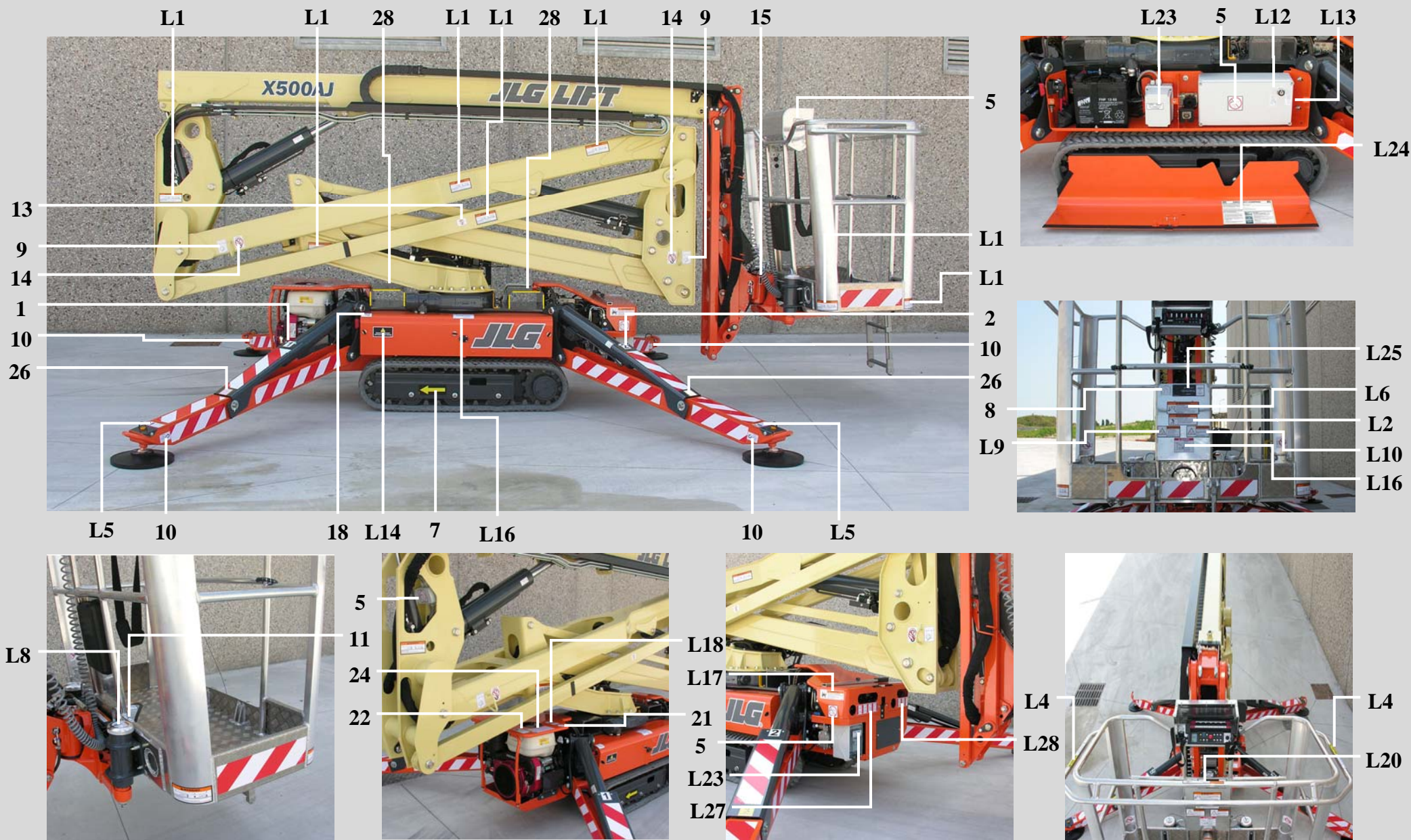

KIT ADESIVI - X500AJ

SET OF DECALS - X500AJ

KIT COLLANTS - X500AJ

AUFKLEBERSATZ - X500AJ

KIT ADHESIVOS - X500AJ

ADHESIEKIT - X500AJ

**Cod. 17224100**

**Tav 01**

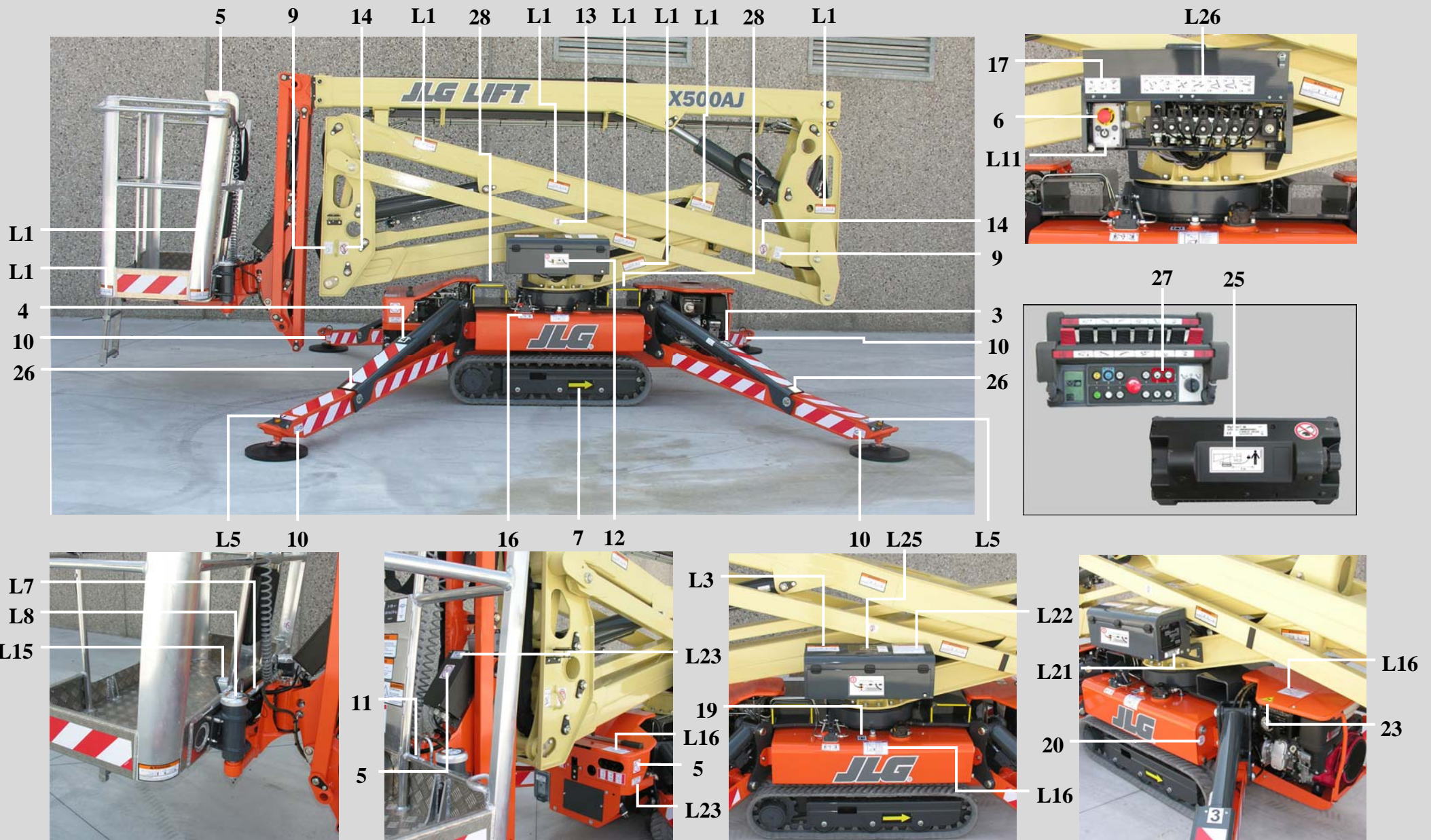

KIT ADESIVI - X500AJ

SET OF DECALS - X500AJ

KIT COLLANTS - X500AJ

AUFKLEBERSATZ - X500AJ

KIT ADHESIVOS - X500AJ

ADHESIEKIT - X500AJ

**Cod. 17224100**

**Tav 02**

**Cod. 17224100**

**KIT ADESIVI PIATTAFORMA AEREA /**  
*AERIAL PLATFORM KIT STICKERS*  
**JLG/ANSI - X500AJ**

**17224100 POSIZIONE ADESIVI / POSITION STICKERS****IN LINGUA / LANGUAGE****JLG****VOLTAGGIO / VOLTAGE**

POSIZIONE	CODICE	REV.	DESCRIZIONE	QUANTITA'
01	06555500	A	ADESIVO NR 1 L=50X60 BIANCO	01
02	06555600	A	ADESIVO NR 2 L=50X60 BIANCO	01
03	06555700	A	ADESIVO N° 3 L=50X60 BIANCO	01
04	06555800	A	ADESIVO N° 4 L=50X60 BIANCO	01
05	1001125483	A	ADESIVO JLG VIETATO LAVARE L=63,5X63,5 MM	06
06	1706898	A	ADESIVO JLG EMERGENCY STOP Ø EST.57,15 Ø INT. 30,58	01
07	06040500	A	ADESIVO DIREZ. TRASLAZIONE FRECCIA GIALLA SFONDO NERO L=61 X 160	02
08	1701640	A	ADESIVO JLG LEGGERE IL MANUALE L= 69,85x69,85 MM	01
09	1703814	A	ADESIVO JLG ATTACCO ANCORAGGIO L=55,56X76,2 MM	04
10	07071200	A	ADESIVO JLG PUNTO DI SOLLEVAMENTO L= 40X66 MM	08
11	1704277	A	ADESIVO JLG ATTACCO CINTURE DI SICUREZZA L= 76,2X19,05 MM	02
12	07506500	A	ADESIVO JLG - EMERGENCY STOP L= 170X100 MM	01
13	07056700	A	ADESIVO JLG DIVIETO DI SOLLEVAMENTO L=40X54,88	02
14	1701499	A	ADESIVO JLG DIVIETO DI SOLLEVAMENTO DAL PUNTO DI ANCORAGGIO L= 55,56X76 MM (**)	04
15	06706500	A	ADESIVO ALLINEAMENTO CESTO (2 PEZZI) L=16X50+13	01
16	06998800	A	ADESIVO DEVIATORE POMPA MANUALE PIATTAFORMA GL17.80XL L=86X34	01
17	07242000	A	ADESIVO SELETTORE 3 POSIZIONI 2° TELECOMANDO	01
18	1702155	A	ADESIVO JLG STACCABATTERIA L= 63,5X50,80 MM	01
19	1701504	A	ADESIVO JLG OLIO IDRAULICO L=50,8x63,5 MM	01
20	06165000	A	ADESIVO LIVELLO OLIO IDRAULICO Ø50 SFONDO BIANCO	01
21	06060000	A	ADESIVO LIVELLO OLIO MOTORE Ø50mm	01
22	1701542	A	ADESIVO JLG CARBURANTE BENZINA L= 101X63,5	01
	1701505	A	ADESIVO JLG CARBURANTE DIESEL L= 50,8X63,5	01
23	06056300	A	ADESIVO PERICOLO SCOTTATURE L=60X51 TRIANGOLARE SFONDO GIALLO	01



**17224100 POSIZIONE ADESIVI / POSITION STICKERS**

**IN LINGUA / LANGUAGE**

**JLG**

**VOLTAGGIO / VOLTAGE**

POSIZIONE	CODICE	REV.	DESCRIZIONE	QUANTITA'
24	06232100	B	ADESIVO ATTENZIONE BENZINA INFIAMMABILE L=170X42 MM	01
25	07240300	B	ADESIVO DISTANZA 1m SU TELE/RADIO COMANDI	01
26	07242100	B	ADESIVO REAZIONE AL SUOLO STABILIZZATORI X500AJ L50X50 - BIANCO	04
27	07071000	B	ADESIVO JLG CLAXON SU PIATTAFORME L=38,3X28,55	01
28	07350300	A	ADESIVO SOLLEVAMENTO PIATTAFORMA CON MULETTO L=90X70 MM	04
29				
30				
31				
32				
33				
34				
35				
36				
37				
38				
39				
40				
41				
42				
43				
44				
45				
46				
47				

**KIT ADESIVI IN LINGUA /  
*LANGUAGEKIT STICKERS*  
JLG/ANSI - X500AJ**

**Cod.**

**172241GB**

**172241FR**

**172241ES**

**172241PT**

<b>172241** ADESIVI IN LINGUA / ADHESIVES IN LANGUAGE</b>	<b>IN LINGUA / LANGUAGE</b>	<b>JLG</b>
	<b>VOLTAGGIO / VOLTAGE</b>	

POSIZIONE	CODICE	REV.	DESCRIZIONE	QUANTITA'
	172241GB		KIT ADESIVI SICUREZZA PIATTAFORMA AEREA X500AJ ANSI LINGUA INGLESE	
L1	07056100	A	ADESIVO JLG PERICOLO SCHIACCIAMENTO L= 140x60,71 MM	14
L2	1706387	A	ADESIVO JLG PERICOLO SCHIACCIAMENTO L=177,80x69,85 MM ( SUL CESTO )	01
L3	1706099	A	ADESIVO JLG PERICOLO SCHIACCIAMENTO L= 161,92X69,85 MM ( A TERRA )	01
L4	1702868	B	ADESIVO JLG PERICOLO SCHIACCIAMENTO MANO L= 241,30X25.40 MM ( SUL CESTO )	02
L5	07056200	A	ADESIVO JLG ATTACCO SCHIACCIAMENTO ARTO INFERIORE L= 110x60 (PRES. STABILIZZATORI )	04
L6	1706386	A	ADESIVO JLG PERICOLO CADUTE L=196,85x76,2 MM	01
L7	07051100	A	ADESIVO JLG PERICOLO CADUTA - RIPRISTINARE I TAPPI L=196,5x35 MM	01
L8	07051000	A	ADESIVO JLG PERICOLO DI CADUTA - SBLOCCARE SOLO NEI CASI PREVISTI L= 50X50 MM	02
L9	1706133	C	ADESIVO JLG PERICOLO RIBALTAMENTO L=139,7X68,85 MM	01
L10	07058600	A	ADESIVO JLG POSIZIONE STABILIZZATORI X390, X550	01
L11	07349200	A	ADESIVO AVVIAMENTO MOTORE DA TERRA LL2010 IIIS L=76,5X37 MM	01
L12	07042100	A	ADESIVO JLG SISTEMA BYPASS PARTE AEREA L=30X50	01
L13	07042200	A	ADESIVO JLG SISTEMA BYPASS TRASLAZIONE L= 30X50	01
L14	1702901	A	ADESIVO JLG ISTRUZIONI DISCESA EMERGENZA / POMPA MAUALE L=114,3x58,73MM	01
L15	3252347	B	ADESIVO JLG ATTENZIONE PEDALE L= 69,85x57,15 MM	01
L16	1706128	E	ADESIVO JLG PERICOLO DI FOLGORAZIONE L=120,65x91,50 MM	05
L17	1703813	A	ADESIVO JLG PERICOLO ESLOSIONE BATTERIE L=149,25X47,62 MM	01
L18	1704972	C	ADESIVO JLG PERICOLO ESPLOSIONE L=63,5x92,07 MM	01
L19				
L20	1706385	C	ADESIVO JLG SCORRIMENTO SBARRA CHIUSURA CESTO L=184,15X25,4 MM	01
L21	1705514	A	ADESIVO JLG CONFORMITA' CSA L= 76,20x22,22 MM	01
L22	1706135	B	ADESIVO JLG USO PIATTAFORMA (GB) L=139,70x88,90 MM	01
L23	07056400	B	ADESIVO JLG PERICOLO 120V - 60HZ L= 75x32,68 MM	04



AGGIORNATO IL / UPDATED 28/11/2019

**Cod. 17224200**

**KIT ADESIVI COMMERCIALI PIATTAFORMA AEREA**  
*AERIAL PLATFORM KIT STICKERS COMMERCIAL*

**JLG/ANSI X500AJ - MK2**

**+ Kit in lingua non inclusi nel codice generale e non gestiti a ricambio**

*+ Language code not included in the standard kit and no spare kit*

**172242GB**

**172242FR**

**172242ES**

**172242PT**

**DA USARE CON / FOR USE WITH**

**17224100 KIT ADESIVI SICUREZZA PIATTAFORMA AEREA JLG/ANSI X500AJ - MK2**  
*/ STICKERS KIT SAFETY AERIAL PLATFORM JLG/ANSI X500AJ - MK2*



Centrare il logo X500AJ in altezza e larghezza fra lo spazio rimanente  
Center the logo X500AJ in height and width among the remaining space

A stabilizzatori chiusi centrare sul braccio sia in altezza che in larghezza il logo JLG LIFT  
A closed centralise regulators on arm is in height to width in the logo JLG LIFT

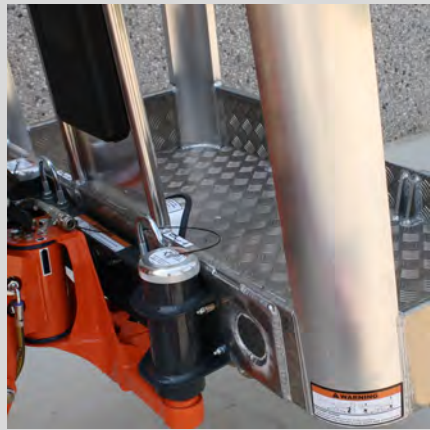
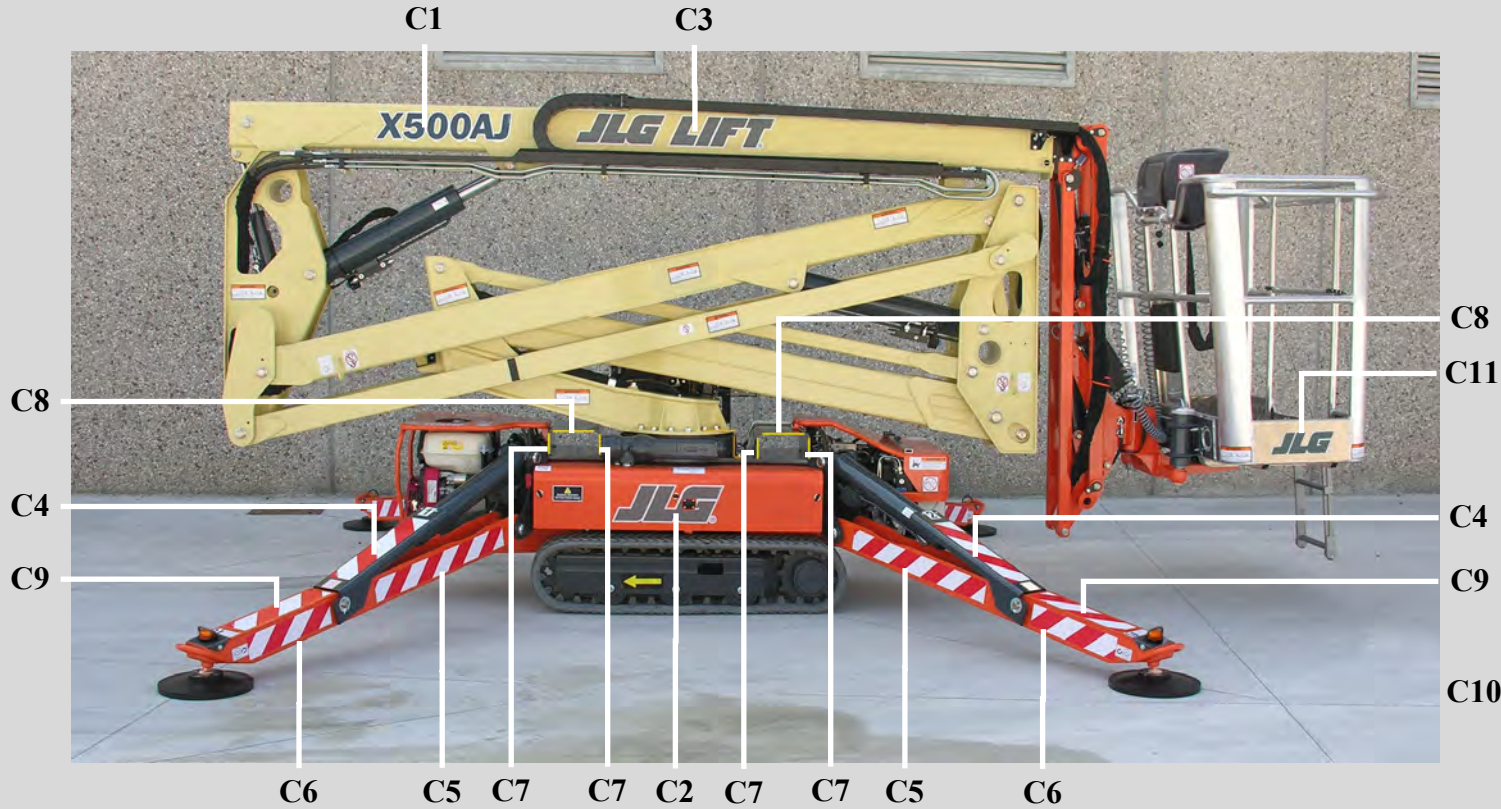

KIT ADESIVI - X500AJ - MK2

SET OF DECALS - X500AJ - MK2

KIT COLLANTS - X500AJ - MK2

AUFKLEBERSATZ - X500AJ - MK2

KIT ADHESIVOS - X500AJ - MK2

ADHESIEKIT - X500AJ - MK2

**cod. 17224200**

Ed. 28/11/2019

Tav 01

**A stabilizzatori chiusi centrare sul braccio sia in altezza che in larghezza il logo JLG LIFT**  
*A closed centralize regulators on arm is in height to width in the logo JLG LIFT*

**Centrare il logo X500AJ in altezza e larghezza fra lo spazio rimanente**  
*Center the logo X500AJ in height and width among the remaining space*

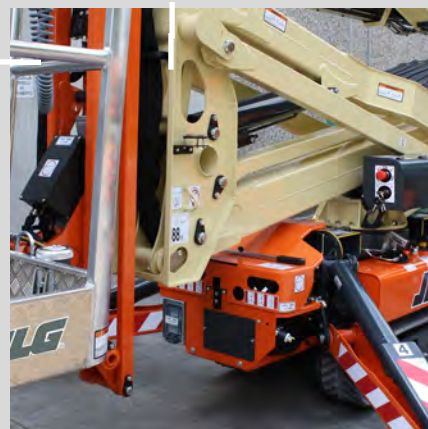
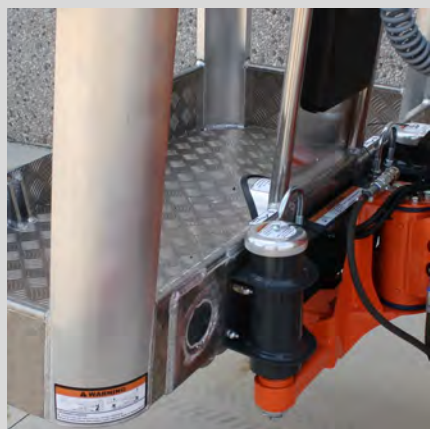
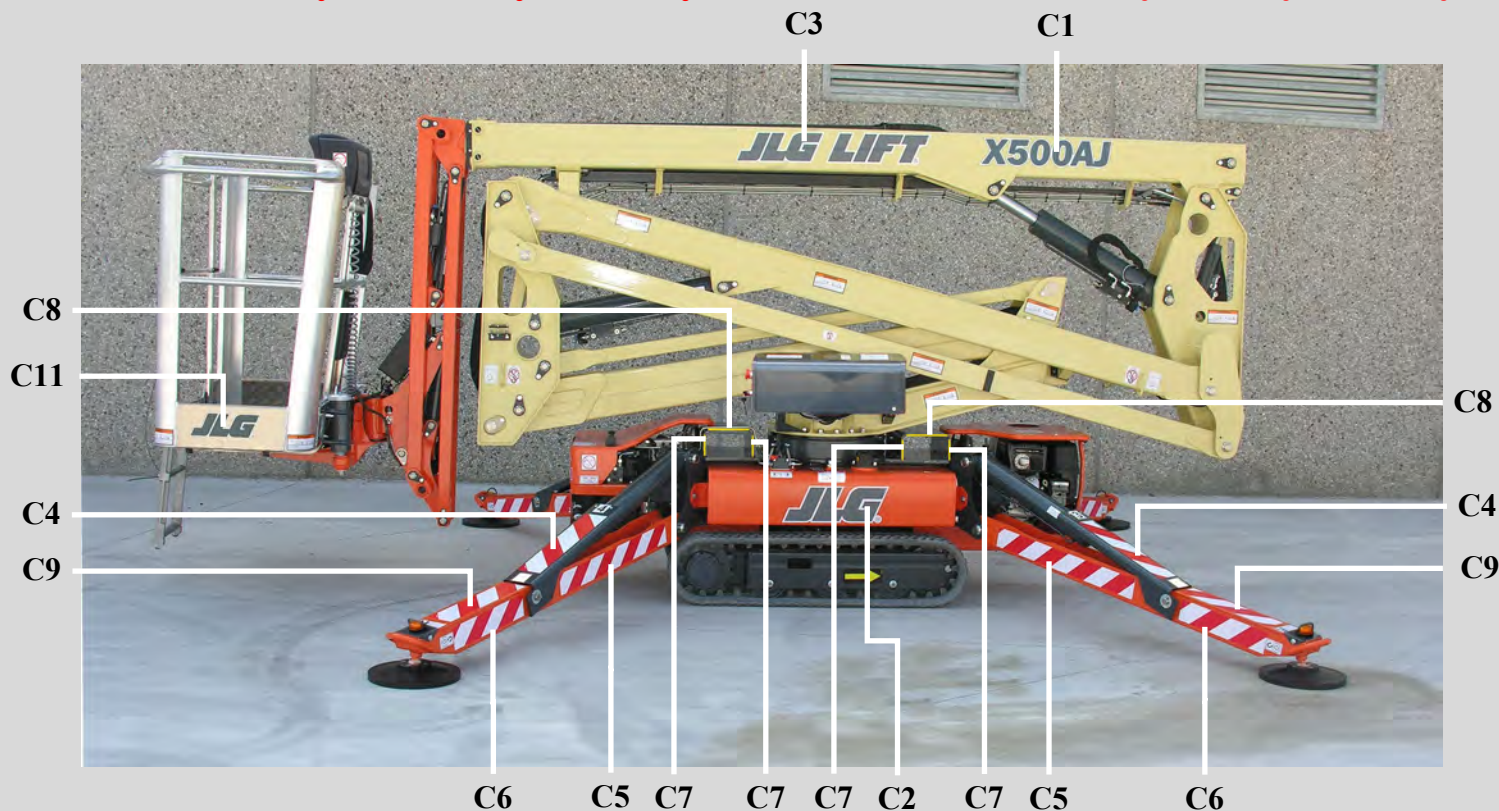

KIT ADESIVI - X500AJ - MK2

SET OF DECALS - X500AJ - MK2

KIT COLLANTS - X500AJ - MK2

AUFKLEBERSATZ - X500AJ - MK2

KIT ADHESIVOS - X500AJ - MK2

ADHESIEKIT - X500AJ - MK2

**cod. 17224200**

Ed. 28/11/2019

Tav 02



**JLG/ANSI X500AJ - MK2 COD. 17224200 POSIZIONE ADESIVI / POSITION STICKERS**  
 Aggiornato il / Updated 28/11/2019

**JLG**

POS.	COD.	REV.	DESCRIZIONE / DESCRIPTION	Q.tà
C1	07846600	A	ADESIVO LOGO X500AJ COLORE GRIGIO PANTONE 432C L=605X130 MM	02
C2	07060500	A	ADESIVO JLG LOGO JLG COLORE GRIGIO PANTONE 432C L=432x150MM (**)	02
C3	07060700	A	ADESIVO JLG LOGO JLG LIFT COLORE GRIGIO PANTONE 432C L=809x130 MM (**)	02
C4	06086700	A	ADESIVO CON RIGHE BIANCHE E ROSSE L=430X100 (**)	04
C5	06039700	A	ADESIVO CON RIGHE BIANCHE ROSSE L= 700 X 80 (**)	10
C6	06436900	A	ADESIVO CON RIGHE BIANCHE ROSSE L= 375 X 80 MM (**)	08
C7	07268300	A	ADESIVO ATTENZIONE SOLLEVAMENTO FORCHE L= 80X7 MM	08
C8	07268400	A	ADESIVO ATTENZIONE SOLLEVAMENTO FORCHE L= 180X7 MM	04
C9	07281100	A	ADESIVO CON RIGHE BIANCHE E ROSSE L=380X100 MM	04
C10	07691500	A	ADESIVO LOGO WWW.JLG.COM COLORE PANTONE 432C L=200X33 MM	01
C11	07690100	A	ADESIVO JLG - LOGO JLG PER CESTO COLORE GRIGIO PANTONE 432C L=300x104,2 MM	02
C12				
C13				
C14				
C15				
C16				
C17				
C18				
C19				
C20				
C21				
C22				
C23				
C24				



AGGIORNATO IL / Updated 30/09/2015

**Cod. 17242800**

**KIT ADESIVI SICUREZZA PIATTAFORMA AEREA /  
AERIAL PLATFORM KIT STICKERS SAFETY  
X17JPLUS**

**+ kit in lingua non inclusi nel codice generale**

*+ language code not included in the standard kit*

**172428IT / 172428GB / 172428FR / 172428DE / 172428ES / 172428NL /  
172428PT / 172428DA / 172428SW / 172428NO / 172428PL**

*DA USARE CON / FOR USE WITH*

**17242900 KIT ADESIVI COMMERCIALI PIATTAFORMA AEREA X17JPLUS /  
STICKER KITS COMMERCIAL AERIAL PLATFORM X17JPLUS**

**17187700 KIT INTEGRAZIONE ADESIVI PER PIATTAFORME LITHIUM /  
STICKER KIT INTEGRATION FOR PLATFORM LITHIUM  
X14J\_14J-H\_X17J\_17JPLUS \_X19J\_X20JPLUS\_X23J**





KIT ADESIVI - X17JPLUS

SET OF DECALS - X17JPLUS

KIT COLLANTS - X17JPLUS

AUFKLEBERSATZ - X17JPLUS

KIT ADHESIVOS - X17JPLUS

ADHESIEKIT - X17JPLUS

**Cod. 17242800**

**Tav 01**

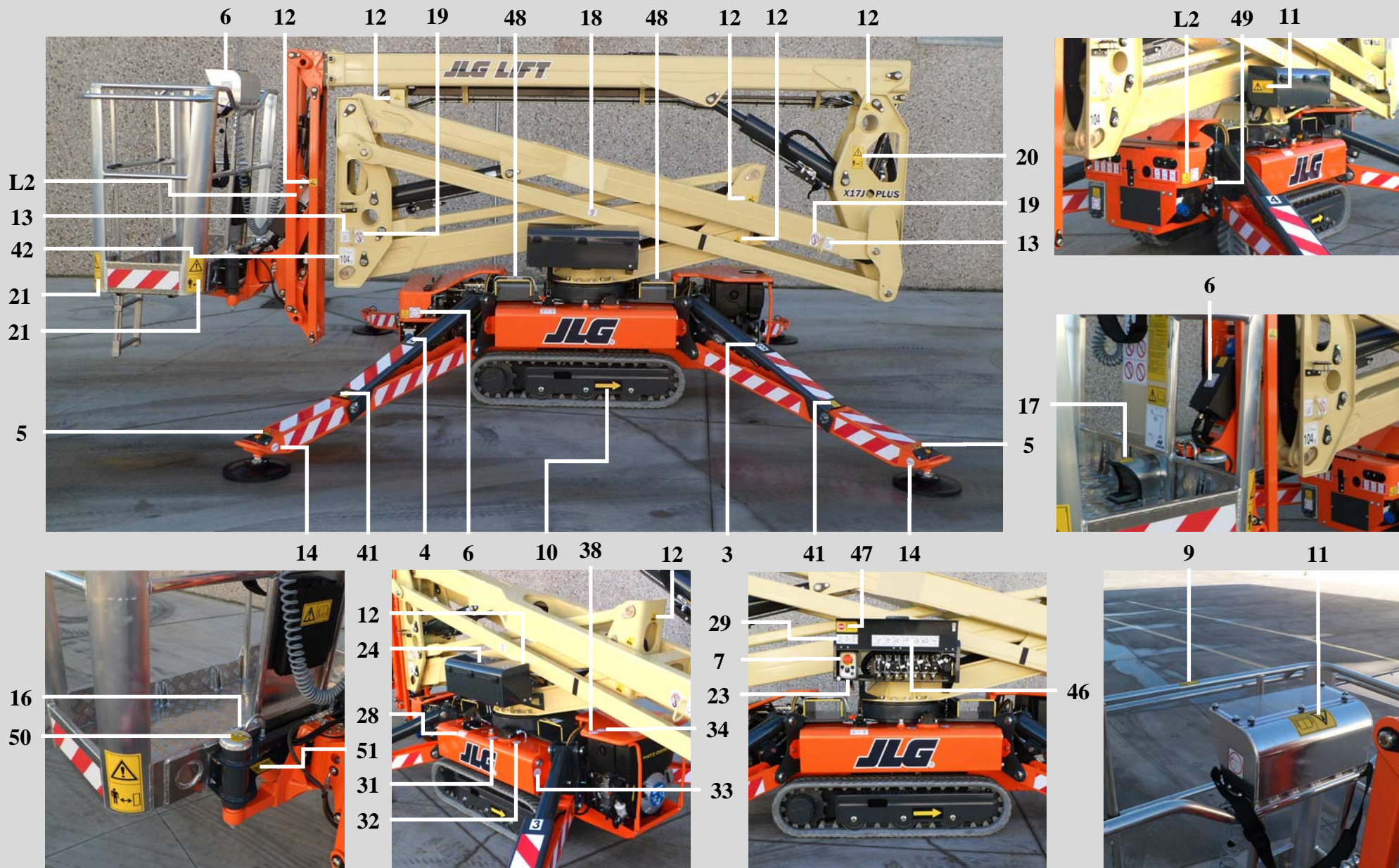

KIT ADESIVI - X17JPLUS

SET OF DECALS - X17JPLUS

KIT COLLANTS - X17JPLUS

AUFKLEBERSATZ - X17JPLUS

KIT ADHESIVOS - X17JPLUS

ADHESIEKIT - X17JPLUS

**Cod. 17242800**

**Tav 02**

**Cod. 17242800**

**KIT ADESIVI SICUREZZA PIATTAFORMA AEREA /  
*AERIAL PLATFORM KIT STICKERS SAFETY*  
**X17JPLUS****

**17242800 POSIZIONE ADESIVI / POSITION ADHESIVE**

**JLG**

POS.	COD.	REV.	DESCRIZIONE / DESCRIPTION	Q.tà
01	06555500	A	ADESIVO NR 1 L=50X60 BIANCO	01
02	06555600	A	ADESIVO NR 2 L=50X60 BIANCO	01
03	06555700	A	ADESIVO N° 3 L=50X60 BIANCO	01
04	06555800	A	ADESIVO N° 4 L=50X60 BIANCO	01
05	06041200	A	ADESIVO SCHIACCIAMENTO PIEDI TRIANGOLARE L=53X46 GIALLO	04
06	1001125483	A	ADESIVO JLG VIETATO LAVARE L=63,5X63,5 MM (**)	06
07	1706898	A	ADESIVO JLG EMERGENCY STOP Ø EST.57,15 Ø INT. 30,58 (**)	01
08	06924300	A	ADESIVO CASCO - IMBRAGATURA - DIVIETI SERIE METAL-IIIS L= 170X250 MM	01
09	1706493	<b>B</b>	ADESIVO JLG SCORRIMENTO SBARRA CHIUSURA CESTO L= 76,2X25,4 MM (**)	01
10	06040500	A	ADESIVO DIREZ. TRASLAZIONE FRECCIA GIALLA SFONDO NERO L=61 X 160	02
11	06040900	A	ADESIVO LEGGERE IL MANUALE L=125 X 65 GIALLO	05
12	06041300	<b>B</b>	ADESIVO ATTENZIONE PERICOLO TAGLI L=35 X 40 MM GIALLO (**)	13
13	1703814	A	ADESIVO JLG ATTACCO ANCORAGGIO L=55,56X76,2 MM (**)	04
14	06044000	A	ADESIVO ATTACCO SOLLEVAMENTO SFONDO BIANCO COLORE BLU Ø40	08
15	06041600	<b>B</b>	ADESIVO CARBURANTE BENZINA COLORE VERDE L=60 X 80 MM	01
16	1704277	A	ADESIVO JLG ATTACCO CINTURE DI SICUREZZA L= 76,2X19,05 MM (**)	02
17	1705828	<b>B</b>	ADESIVO JLG INTERUTTORE PEDALE L= 69,85X54 (**)	01
18	07056700	A	ADESIVO JLG DIVIETO DI SOLLEVAMENTO L=54,88X40 (**)	02
19	1701499	A	ADESIVO JLG DIVIETO DI SOLLEVAMENTO DAL PUNTO DI ANCORAGGIO L= 55,56X76 MM (**)	04
20	07058800	A	ADESIVO PERICOLO MANTENERE LE DISTANZE L=65X130 MM	02
21	06040300	A	ADESIVO PERICOLO MANTENERE LE DISTANZE GIALLO L=100 X 200 MM (**)	04
22	1706098	<b>B</b>	ADESIVO JLG PERICOLO ESPLOSIONE L=63,5X117,475 MM (**)	01
23	07349200	A	ADESIVO AVVIAMENTO MOTORE DA TERRA LL2010 IIIS L=76,5X37 MM	01
24	07056800	<b>B</b>	ADESIVO JLG DISCESA DI EMERGENZA ALL'INTERNO L=114X130 MM (**)	02



**17242800 POSIZIONE ADESIVI / POSITION ADHESIVE**

**JLG**

POS.	COD.	REV.	DESCRIZIONE / DESCRIPTION	Q.tà
25	06086000	A	ADESIVO SISTEMA BYPASS TRASLAZIONE L=30X50	01
26	06085900	A	ADESIVO SISTEMA BYPASS PARTE AEREA L=30X50	01
27	06706500	A	ADESIVO ALLINEAMENTO CESTO (2 PEZZI) L=16X50+13	01
28	06998800	A	ADESIVO DEVIATORE POMPA MANUALE PIATTAFORMA GL17.80XL L=86X34	01
29	07242000	A	ADESIVO SELETTORE 3 POSIZIONI 2° TELECOMANDO	01
30	1702155	A	ADESIVO JLG STACCABATTERIA L= 63,5X50,80 MM (**)	01
31	1701504	A	ADESIVO JLG OLIO IDRAULICO L=50,8x63,5 MM (**)	01
32	06164700	A	ADESIVO FILTRO OLIO Ø50 SFONDO BIANCO	01
33	06165000	A	ADESIVO LIVELLO OLIO IDRAULICO Ø50 SFONDO BIANCO	01
34	06060000	A	ADESIVO LIVELLO OLIO MOTORE Ø50mm	01
35	06227200	B	ADESIVO CONTROLLARE LIVELLO OLIO MOTORE L=80X80 MM	01
36	1701505	A	ADESIVO JLG CARBURANTE DIESEL L= 50,8X63,5 (**)	01
37	06056300	A	ADESIVO PERICOLO SCOTTATURE L=60X51 TRIANGOLARE SFONDO GIALLO	01
38	06164600	A	ADESIVO FILTRO ARIA Ø50 SFONDO BIANCO (**)	01
39	06232100	B	ADESIVO ATTENZIONE BENZINA INFIAMMABILE L=170X42 MM	01
40	07240300	B	ADESIVO DISTANZA 1m SU TELE/RADIO COMANDI	01
41	07198800	A	ADESIVO REAZIONE AL SUOLO STABILIZZATORI LL1775 L=45x48 MM	04
42	07034200	B	ADESIVO RUMORE 104 dB L=90X100	02
43	07243000	A	ADESIVO JLG X17JPLUS PORTATA CESTO 2 PERSONE L=135X145	01
44	1608710001	C	ADESIVO PULSANTI DISTR. A TERRA LATO SX GL17.80 L=194X50 MM	01
45	1608710002	C	ADESIVO PULSANTI DISTRIB A TERRA GL 17.80 LATO SX L= 150X50 mm	01
46	07199100	A	ADESIVO COMANDI AEREI DA TERRA LL1775	01

**17242800 POSIZIONE ADESIVI / POSITION ADHESIVE**

**JLG**

POS.	COD.	REV.	DESCRIZIONE / DESCRIPTION	Q.tà
47	06254800	B	ADESIVO STOP EMERGENZA SFONDO GIALLO L=70X50 MM (**)	01
48	07350300	A	ADESIVO SOLLEVAMENTO PIATTAFORMA CON MULETTO L=90X70 MM	04
49	06136900	A	ADESIVO PUNTI INGRASSAGGIO Ø 55 TESTO NERO - SFONDO BIANCO (**)	01
50	06448200	B	ADESIVO "SBLOCCARE SOLO NEI CASI PREVISTI" Ø 60 MM	02
51	06448100	B	ADESIVO RIPRISTINARE I TAPPI FERMO GUIDA L= 100X35 MM	02
52				
53				
54				
55				
56				
57				
58				
59				
60				
61				
62				
63				
64				
65				
66				
67				
68				
69				
70	07669000	B	ADESIVO JLG X17JPLUS PORTATA CESTO 1 PERSONA L=135X145 MM - NON IN DISTINTA	01

**KIT ADESIVI IN LINGUA / *LANGUAGE KIT STICKERS***  
**X17JPLUS**

**Cod.**

**172428IT**

**172428GB**

**172428FR**

**172428DE**

**172428ES**

**172428NL**

**172428PT**

**172428SW**

**172428DA**

**172428NO**

**172428PO**

**172428\*\* POSIZIONE ADESIVI IN LINGUA /**  
**POSITION LANGUAGE STICKERS**

**IN LINGUA / LANGUAGE**

**VOLTAGGIO / VOLTAGE**

**JLG**

POS.	COD.	REV.	DESCRIZIONE / DESCRIPTION	Q.tà
	172428IT		ADESIVI PIATTAFORMA AEREA X17JPLUS LINGUA ITALIANO	
L1	06555300	<b>B</b>	ADESIVO USO PIATTAFORMA LINGUA ITALIANA LL 23.12 L=128X230 MM	01
L2	06561200	<b>B</b>	ADESIVO PERICOLO 230 VOLT 16A GIALLO	05
L3	07319100	A	ADESIVO DISCESA DI EMERGENZA LL 1775/200 MOTORE TERMICO E LITHIUM - ITA L=290X205 MM	01
	172428GB		ADESIVI PIATTAFORMA AEREA X17JPLUSLINGUA INGLESE	
L1	06562600	<b>B</b>	ADESIVO USO PIATTAFORMA INGLESE L=128X230 MM	01
L2	06561200	<b>B</b>	ADESIVO PERICOLO 230 VOLT 16A GIALLO	05
L2	06042400	<b>B</b>	ADESIVO PERICOLO 110 VOLT 16A GIALLO	05
L3	073191GB	A	ADESIVO DISCESA DI EMERGENZA LL 1775/200 MOTORE TERMICO E LITHIUM - ING L=290X205 MM	01
	172428FR		ADESIVI PIATTAFORMA AEREA X17JPLUS LINGUA FRANCESE	
L1	06562700	<b>B</b>	ADESIVO USO PIATTAFORMA FRANCESE L=128X230 MM	01
L2	06561200	<b>B</b>	ADESIVO PERICOLO 230 VOLT 16A GIALLO	05
L3	073191FR	A	ADESIVO DISCESA DI EMERGENZA LL1775/200 MOTORE TERMICO E LITHIUM - FRA L=290X205 MM	01
	172428DE		ADESIVI PIATTAFORMA AEREA X17JPLUS LINGUA TEDESCO	
L1	06562800	<b>B</b>	ADESIVO USO PIATTAFORMA TEDESCO L=128X230 MM	01
L2	06561200	<b>B</b>	ADESIVO PERICOLO 230 VOLT 16A GIALLO	05
L3	073191DE	A	ADESIVO DISCESA DI EMERGENZA LL 1775/200 MOTORE TERMICO E LITHIUM - TED L=290X205 MM	01

**172428\*\* POSIZIONE ADESIVI IN LINGUA /**  
**POSITION LANGUAGE STICKERS**

**IN LINGUA / LANGUAGE**

**VOLTAGGIO / VOLTAGE**

**JLG**

POS.	COD.	REV.	DESCRIZIONE / DESCRIPTION	Q.tà
	172428ES		ADESIVI PIATTAFORMA AEREA X17JPLUS LINGUA SPAGNOLO	
L1	06562900	<b>B</b>	ADESIVO USO PIATTAFORMA SPAGNOLO L=128X230 MM	01
L2	06561200	<b>B</b>	ADESIVO PERICOLO 230 VOLT 16A GIALLO	05
L3	073191ES	A	ADESIVO DISCESA DI EMERGENZA LL 1775/200 MOTORE TERMICO E LITHIUM - SPA L=290X205 MM	01
	172428NL		ADESIVI PIATTAFORMA AEREA X17JPLUS LINGUA OLANDESE	
L1	06563000	<b>B</b>	ADESIVO USO PIATTAFORMA OLANDESE L=128X230 MM	01
L2	06561200	<b>B</b>	ADESIVO PERICOLO 230 VOLT 16A GIALLO	05
L3	073191NL	A	ADESIVO DISCESA DI EMERGENZA LL 1775/200 MOTORE TERMICO E LITHIUM - OLA L=290X205 MM	01
	172428PT		ADESIVI PIATTAFORMA AEREA X17JPLUS LINGUA PORTOGHESE	
L1	06563100	<b>B</b>	ADESIVO USO PIATTAFORMA PORTOGHESE L=128X230 MM	01
L2	06561200	<b>B</b>	ADESIVO PERICOLO 230 VOLT 16A GIALLO	05
L3	073191PT	A	ADESIVO DISCESA DI EMERGENZA LL 1775/200 MOTORE TERMICO E LITHIUM - OLA L=290X205 MM	01
	172428SW		ADESIVI PIATTAFORMA AEREA X17JPLUS LINGUA SVEDESE	
L1	07137300	<b>B</b>	ADESIVO USO PIATTAFORMA AEREA CINGOLATA - SVEDESE L= 128X230 MM	01
L2	06561200	<b>B</b>	ADESIVO PERICOLO 230 VOLT 16A GIALLO	05
L3	073191SW	A	ADESIVO DISCESA DI EMERGENZA LL 1775/200 MOTORE TERMICO E LITHIUM - SWE L=290X205 MM	01
	172428DA		ADESIVI PIATTAFORMA AEREA X17JPLUS LINGUA DANESE	
L1	07138100	<b>B</b>	ADESIVO USO PIATTAFORMA AEREA CINGOLATA - DANESE L= 128X230 MM **	01
L2	06561200	<b>B</b>	ADESIVO PERICOLO 230 VOLT 16A GIALLO	05
L3	073191DA	A	ADESIVO DISCESA DI EMERGENZA LL 1775/200 MOTORE TERMICO E LITHIUM - DAN L=290X205 MM	01



**Cod. 17242900 (no a ricambio/no spare kit)**

**KIT ADESIVI COMMERCIALI PIATTAFORMA AEREA /  
*AERIAL PLATFORM KIT STICKERS COMMERCIAL*  
**X17JPLUS****

*DA USARE CON / FOR USE WITH*

**17776400 KIT ADESIVI DI SICUREZZA PIATTAFORMA AEREA X17JPLUS MK2 /  
*STICKER KITS SAFETY AERIAL PLATFORM X17JPLUS MK2***

**17242800 KIT ADESIVI DI SICUREZZA PIATTAFORMA AEREA X17JPLUS/  
*STICKER KITS SAFETY AERIAL PLATFORM X17JPLUS***

**17187700 KIT INTEGRAZIONE ADESIVI PER PIATTAFORME LITHIUM /  
*STICKER KIT INTEGRATION FOR PLATFORM LITHIUM*  
**X14J / 14J-H / X17J / 17JPLUS / X19J / X20JPLUS / X23****





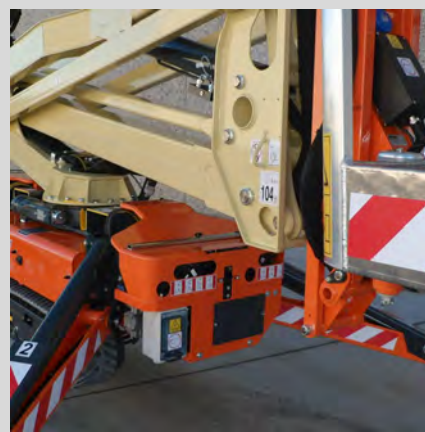
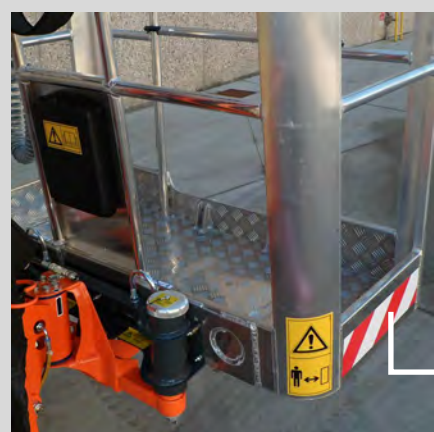
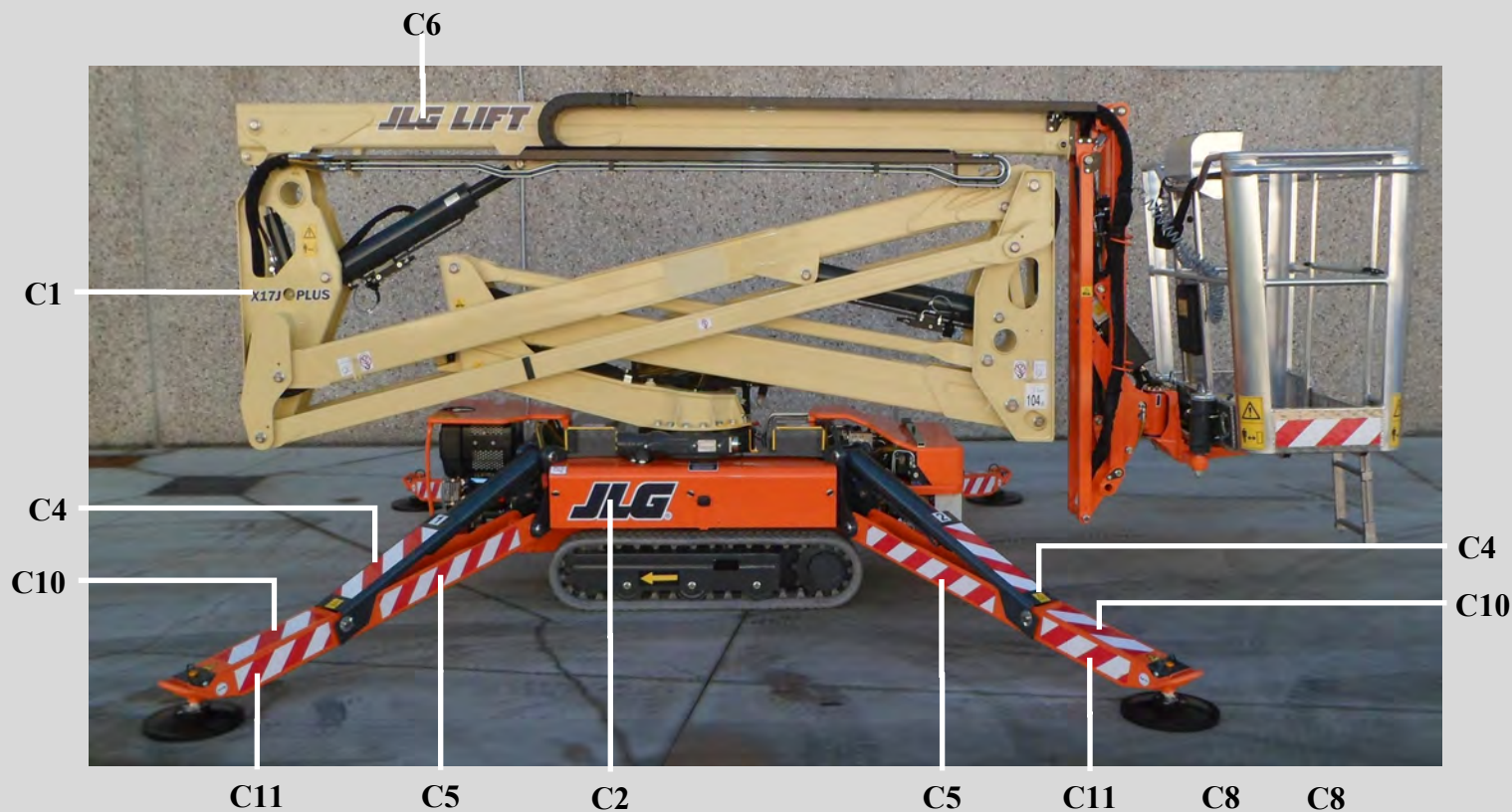

	KIT ADESIVI - X17JPLUS	AUFKLEBERSATZ - X17JPLUS	<b>cod. 17242900</b>	
	SET OF DECALS - X17JPLUS	KIT ADHESIVOS - X17JPLUS		
	KIT COLLANTS - X17JPLUS	ADHESIEKIT - X17JPLUS	Ed. 19/11/2014	Tav 01

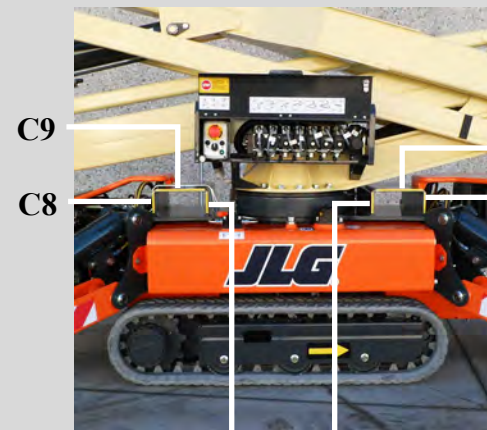

KIT ADESIVI - X17JPLUS

SET OF DECALS - X17JPLUS

KIT COLLANTS - X17JPLUS

AUFKLEBERSATZ - X17JPLUS

KIT ADHESIVOS - X17JPLUS

ADHESIEKIT - X17JPLUS

**cod. 17242900**

Ed. 19/11/2014

Tav 02

**Cod. 17242900 (no a ricambio/no spare kit)**

**KIT ADESIVI COMMERCIALI PIATTAFORMA AEREA /  
*AERIAL PLATFORM KIT STICKERS COMMERCIAL*  
**X17JPLUS****

17242900 POSIZIONE ADESIVI / POSITION ADHESIVE **Aggiornato il / Updated 19/11/2014**

**JLG**

POS.	COD.	REV.	DESCRIZIONE / DESCRIPTION	Q.tà
C1	07397100	A	ADESIVO JLG LOGO PIATTAFORMA AEREA CINGOLATA X7JPLUS L= 334X46 MM	02
C2	07060500	A	ADESIVO LOGO JLG L=432x150MM	02
C3		A		
C4	06086700	A	ADESIVO CON RIGHE BIANCHE E ROSSE L=430X100 (**)	06
C5	06039700	A	ADESIVO CON RIGHE BIANCHE ROSSE L= 700 X 80 (**)	09
C6	07060600	A	ADESIVO LOGO JLG LIFT L=624x100 MM	02
C7				
C8	07268300	A	ADESIVO ATTENZIONE SOLLEVAMENTO FORCHE L=80X7 MM	08
C9	07268400	A	ADESIVO ATTENZIONE SOLLEVAMENTO FORCHE L=180X7 MM	04
C10	07281100	A	ADESIVO CON RIGHE BIANCHE E ROSSE L= 380X100 MM	04
C11	06436900	A	ADESIVO CON RIGHE BIANCHE E ROSSE L= 375X80 MM	08
C12				
C13				
C14				
C15				
C16				
C17				
C18				
C19				
C20				
C21				
C22				
C23				
C24				

**KIT ADESIVI SICUREZZA PIATTAFORMA AEREA /**  
*AERIAL PLATFORM KIT STICKERS SAFETY*  
**JLG/CE - X17JPLUS - MK2**

**Cod. 17776400**

**kit in lingua non inclusi nel codice generale / language code not included in the standard kit**

**177764IT / 177764GB / 177764FR / 177764DE / 177764ES / 177764NL / 177764SW /**  
**177764PT / 177764DA / 177764NO / 177764RU / 177764PL / 177764SL / 177764FI /**  
**177764CE / 177764JA /**

*DA USARE CON / FOR USE WITH*

**17242900 KIT ADESIVI COMMERCIALI PIATTAFORMA AEREA X17JPLUS /**  
*STICKER KITS COMMERCIAL AERIAL PLATFORM X17JPLUS*

**17187700 KIT INTEGRAZIONE ADESIVI PER PIATTAFORME AEREE JLG/CE LITHIUM /**  
*INTEGRATION KIT STICKERS PLATFORMS JLG / CE LITHIUM*





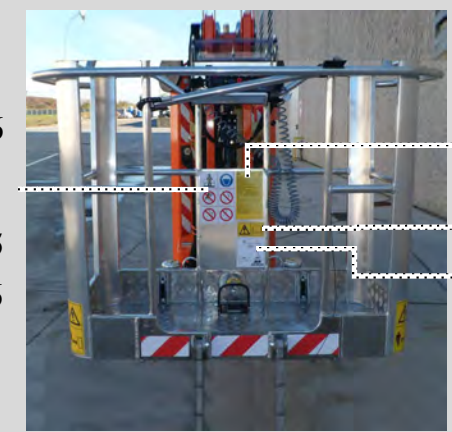
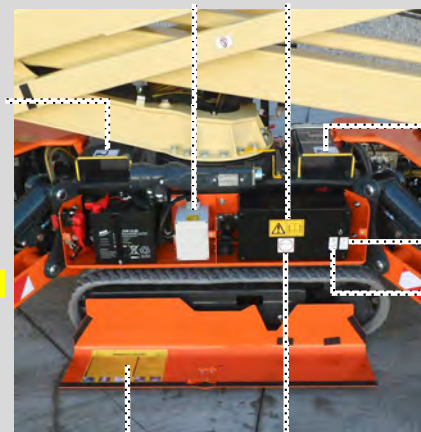
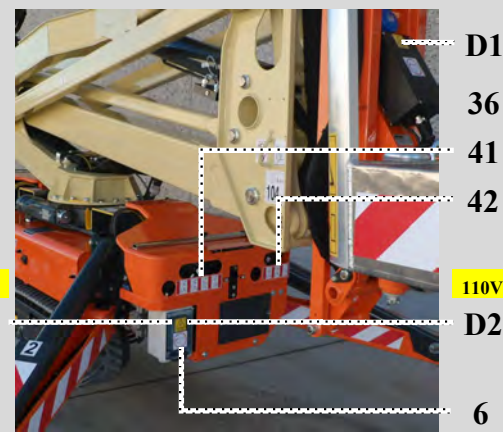
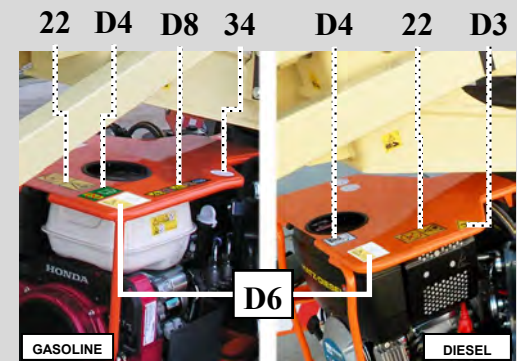
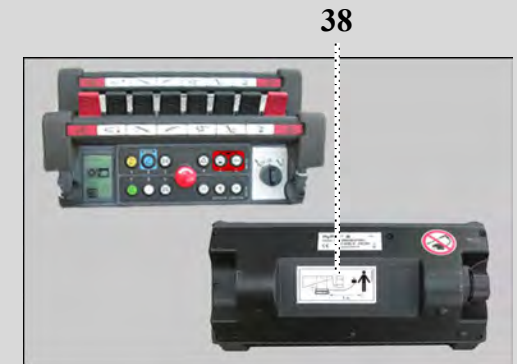
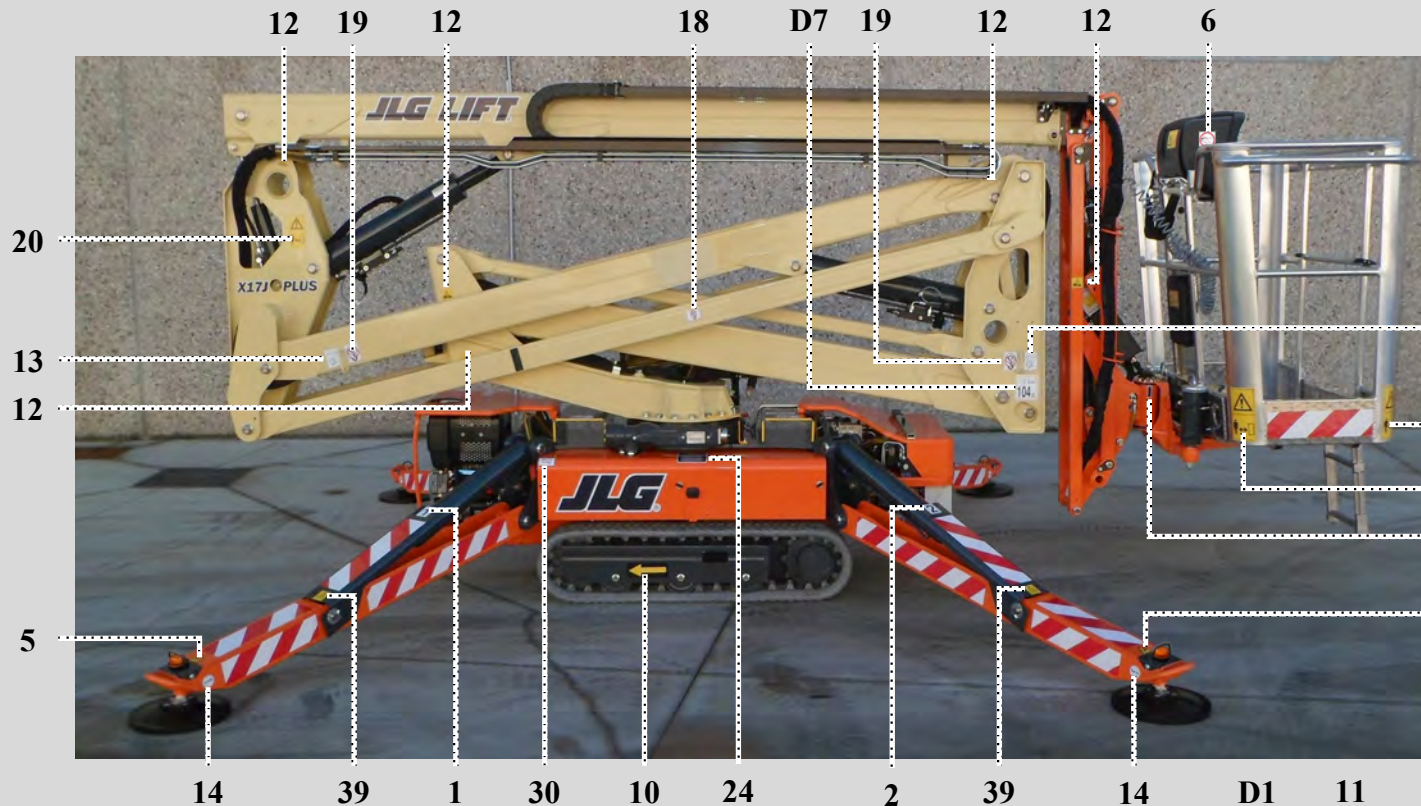

KIT ADESIVI - X17JPLUS - MK2

SET OF DECALS - X17JPLUS - MK2

KIT COLLANTS - X17JPLUS - MK2

AUFKLEBERSATZ - X17JPLUS - MK2

KIT ADHESIVOS - X17JPLUS - MK2

ADHESIEKIT - X17JPLUS - MK2

**Cod. 17776400**

**Tav 01**



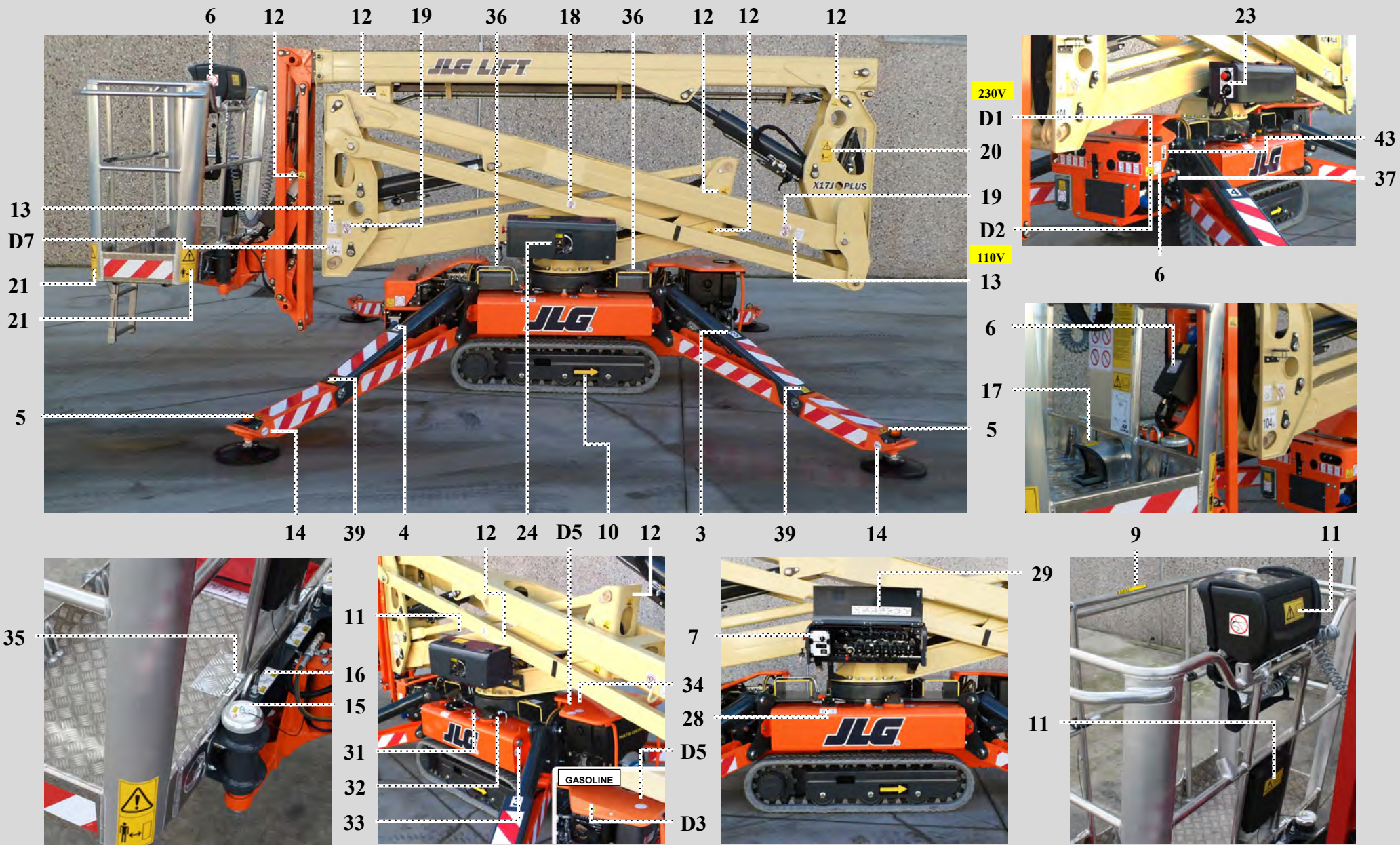

KIT ADESIVI - X17JPLUS - MK2

SET OF DECALS - X17JPLUS - MK2

KIT COLLANTS - X17JPLUS - MK2

AUFKLEBERSATZ - X17JPLUS - MK2

KIT ADHESIVOS - X17JPLUS - MK2

ADHESIEKIT - X17JPLUS - MK2

**Cod. 17776400**

**Tav 02**

17776400 POSIZIONE ADESIVI / POSITION ADHESIVE

JLG

POS.	COD.	REV.	DESCRIZIONE / DESCRIPTION	Q.tà
01	06555500	A	ADESIVO NR 1 L=50X60 BIANCO	01
02	06555600	A	ADESIVO NR 2 L=50X60 BIANCO	01
03	06555700	A	ADESIVO N° 3 L=50X60 BIANCO	01
04	06555800	A	ADESIVO N° 4 L=50X60 BIANCO	01
05	06041200	A	ADESIVO SCHIACCIAMENTO PIEDI TRIANGOLARE L=53X46 GIALLO	04
06	1001125483	A	ADESIVO JLG VIETATO LAVARE L=63,5X63,5 MM (**)	06
07	07668300	A	ADESIVO SELETTORE SCATOLA COMANDI TERRA / CESTO L=105X155 MM	01
08	07878400	A	ADESIVO CASCO IMBRAGATURA E DIVIETI LL1370 L=175X118 MM	01
09	1706493	B	ADESIVO JLG SCORRIMENTO SBARRA CHIUSURA CESTO L= 76,2X25,4 MM <b>_MOD_B (**)</b>	01
10	06040500	A	ADESIVO DIREZ. TRASLAZIONE FRECCIA GIALLA SFONDO NERO L=61 X 160	02
11	06040900	A	ADESIVO LEGGERE IL MANUALE L=125 X 65 GIALLO	05
12	06041300	B	ADESIVO ATTENZIONE PERICOLO TAGLI L=35 X 40 MM GIALLO <b>_MOD_B (**)</b>	13
13	1703814	A	ADESIVO JLG ATTACCO ANCORAGGIO L=55,56X76,2 MM (**)	04
14	06044000	A	ADESIVO ATTACCO SOLLEVAMENTO SFONDO BIANCO COLORE BLU Ø40 MM	08
15	06448200	B	ADESIVO SBLOCCARE SOLO NEI CASI PREVISTI Ø 60 MM <b>_MOD_B</b>	02
16	06448100	B	ADESIVO RIPRISTINARE I TAPPI FERMO GUIDA L= 100X35 MM <b>_MOD_B</b>	02
17	1705828	B	ADESIVO JLG INTERUTTORE PEDALE L= 69,85X54 <b>_MOD_B (**)</b>	01
18	07056700	A	ADESIVO JLG DIVIETO DI SOLLEVAMENTO L=54,88X40 (**)	02
19	1701499	A	ADESIVO JLG DIVIETO DI SOLLEVAMENTO DAL PUNTO DI ANCORAGGIO L= 55,56X76 MM (**)	04
20	07058800	A	ADESIVO PERICOLO MANTENERE LE DISTANZE L=65X130 MM	02
21	06040300	A	ADESIVO PERICOLO MANTENERE LE DISTANZE GIALLO L=100 X 200 MM (**)	04
22	1706098	B	ADESIVO JLG PERICOLO ESPLOSIONE L=63,5X117,475 MM <b>_MOD_B (**)</b>	01
23	07668200	B	ADESIVO EMERGENCY STOP E BLOCCHETTO ACCENSIONE L=85x160 MM <b>_MOD_B</b>	01
24	07056800	B	ADESIVO JLG DISCESA DI EMERGENZA ALL'INTERNO L=114X130 MM <b>_MOD_B (**)</b>	02

**17776400 POSIZIONE ADESIVI / POSITION ADHESIVE**

**JLG**

POS.	COD.	REV.	DESCRIZIONE / DESCRIPTION	Q.tà
25	06086000	A	ADESIVO SISTEMA BYPASS TRASLAZIONE L=30X50	01
26	06085900	A	ADESIVO SISTEMA BYPASS PARTE AEREA L=30X50	01
27	06706500	A	ADESIVO ALLINEAMENTO CESTO (2 PEZZI) L=16X50+13	01
28	06998800	A	ADESIVO DEVIATORE POMPA MANUALE PIATTAFORMA GL17.80XL L=86X34	01
29	07668100	A	ADESIVO PULSANTI DISTRIBUTORE PARTE AEREA LL2614 L=318X52 MM	01
30	1702155	A	ADESIVO JLG STACCABATTERIA L= 63,5X50,80 MM (**)	01
31	1701504	A	ADESIVO JLG OLIO IDRAULICO L=50,8x63,5 MM (**)	01
32	06164700	A	ADESIVO FILTRO OLIO Ø50 SFONDO BIANCO	01
33	06165000	A	ADESIVO LIVELLO OLIO IDRAULICO Ø50 SFONDO BIANCO	01
34	06060000	A	ADESIVO LIVELLO OLIO MOTORE Ø50mm	01
35	1704277	A	ADESIVO JLG ATTACCO CINTURE DI SICUREZZA L= 76,2X19,05 MM (**)	02
36	07350300	A	ADESIVO SOLLEVAMENTO PIATTAFORMA CON MULETTO L=90X70 MM	04
37	06136900	A	ADESIVO PUNTI INGRASSAGGIO Ø 55 TESTO NERO - SFONDO BIANCO (**)	01
38	07240300	B	ADESIVO DISTANZA 1m SU TELE/RADIO COMANDI <b>_MOD_B</b>	01
39	07198800	A	ADESIVO REAZIONE AL SUOLO STABILIZZATORI LL1775 L=45x48 MM	04
40	07243000	A	ADESIVO JLG X17JPLUS PORTATA CESTO 2 PERSONE L=135X145	01
41	1608710001	C	ADESIVO PULSANTI DISTR. A TERRA LATO SX GL17.80 L=194X50 MM <b>_MOD_C</b>	01
42	1608710002	C	ADESIVO PULSANTI DISTRIB A TERRA GL 17.80 LATO SX L= 150X50 MM <b>_MOD_C</b>	01
43	1704125	A	ADESIVO JLG ATTACCO ARIA E ACQUA L=25,4X76,2 MM ( da montare dalla prossima barra in produzione da gennaio 2018 )	01
44				
45				

17776400 POSIZIONE ADESIVI / POSITION ADHESIVE

JLG

POS.	COD.	REV.	ADESIVI IN DISTINTA MACCHINA / STICKERS IN LIST MACHINE	Q.tà
D1	06561200	B	ADESIVO PERICOLO 230 VOLT16 AMPERE GIALLO L=47X47 MM <b>_MOD_B</b>	05
	06042400	B	ADESIVO PERICOLO 110 VOLT16 AMPERE GIALLO L=47 X 47 MM <b>_MOD_B</b>	05
	06257300	A	ADESIVO PERICOLO 240 VOLT GIALLO L=47 X 47 MM	05
D2	07668000	A	ADESIVO PERICOLO 110 VOLT 32A GIALLO L=47 X 47 MM	02
D3	06056300	A	ADESIVO PERICOLO SCOTTATURE TRIANGOLARE SFONDO GIALLO L=60X51 MM	01
D4	06041600	B	ADESIVO CARBURANTE BENZINA COLORE VERDE L=60 X 80 MM <b>_MOD_B</b>	01
	1701505	A	ADESIVO JLG CARBURANTE DIESEL L= 50,8X63,5 (**)	01
D5	06164600	A	ADESIVO FILTRO ARIA SFONDO BIANCO Ø50 MM	01
D6	06227200	B	ADESIVO CONTROLLARE LIVELLO OLIO MOTORE L=80X80 MM <b>_MOD_B</b>	01
D7	07034200	B	ADESIVO RUMORE 104 dB L=90X100 MM <b>_MOD_B</b>	02
D8	06232100	B	ADESIVO ATTENZIONE BENZINA INFIAMMABILE <b>_MOD_B</b>	01
D19				
D12				
D13				
D14				
D15				
D16				
D17				
D19				
D20				
			<b>PER MACCHINE CON CESTO A 1 PERSONA / FOR MACHINE WITH BASKET 1 PERSONA</b>	
40	07669000	B	ADESIVO JLG X17JPLUS PORTATA CESTO 1 PERSONA L=110X145 MM " non in distinta "	01

**177764\*\* POSIZIONE ADESIVI IN LINGUA /**  
**POSITION LANGUAGE STICKERS**

**IN LINGUA / LANGUAGE**

**JLG**

POS.	COD.	REV.	DESCRIZIONE / DESCRIPTION	Q.tà
	177764IT		ADESIVI PIATTAFORMA AEREA X17JPLUS MK2 - LINGUA ITALIANO	
L1	06555300	C	ADESIVO USO PIATTAFORMA AEREA CINGOLATA - ITALIANO L=128X230_MOD_C	01
L2	07319100	A	ADESIVO DISCESA DI EMERGENZA LL 1775/200 MOTORE TERMICO E LITHIUM - ITA L=290X205 MM	01
	177764GB		ADESIVI PIATTAFORMA AEREA X17JPLUS MK2 - LINGUA INGLESE	
L1	06562600	C	ADESIVO USO PIATTAFORMA AEREA CINGOLATA - INGLESE L=128X230_MOD_C	01
L2	073191GB	A	ADESIVO DISCESA DI EMERGENZA LL 1775/200 MOTORE TERMICO E LITHIUM - ING L=290X205 MM	01
	177764FR		ADESIVI PIATTAFORMA AEREA X17JPLUS MK2 - LINGUA FRANCESE	
L1	06562700	C	ADESIVO USO PIATTAFORMA AEREA CINGOLATA - FRANCESE L=128X230_MOD_C	01
L2	073191FR	A	ADESIVO DISCESA DI EMERGENZA LL1775/200 MOTORE TERMICO E LITHIUM - FRA L=290X205 MM	01
	177764DE		ADESIVI PIATTAFORMA AEREA X17JPLUS MK2 - LINGUA TEDESCO	
L1	06562800	C	ADESIVO USO PIATTAFORMA AEREA CINGOLATA - TEDESCO L=128X230_MOD_C	01
L2	073191DE	A	ADESIVO DISCESA DI EMERGENZA LL 1775/200 MOTORE TERMICO E LITHIUM - TED L=290X205 MM	01
	177764ES		ADESIVI PIATTAFORMA AEREA X17JPLUS MK2 - LINGUA SPAGNOLO	
L1	06562900	C	ADESIVO USO PIATTAFORMA AEREA CINGOLATA - SPAGNOLO L=128X230_MOD_C	01
L2	073191ES	A	ADESIVO DISCESA DI EMER. LL 1775/200 MOT. TERMICO E LITHIUM - SPA L=290X205 MM	01
	177764NL		ADESIVI PIATTAFORMA AEREA X17JPLUS MK2 - LINGUA OLANDESE	
L1	06563000	C	ADESIVO USO PIATTAFORMA AEREA CINGOLATA - OLANDESE L=128X230_MOD_C	01
L2	073191NL	A	ADESIVO DISCESA DI EMERGENZA LL 1775/200 MOTORE TERMICO E LITHIUM - OLA L=290X205 MM	01

**177764\*\* POSIZIONE ADESIVI IN LINGUA /**  
**POSITION LANGUAGE STICKERS**

**IN LINGUA / LANGUAGE**

**JLG**

POS.	COD.	REV.	DESCRIZIONE / DESCRIPTION	Q.tà
	177764SW		ADESIVI PIATTAFORMA AEREA X17JPLUS MK2 - LINGUA SVEDESE	
L1	07137300	<b>C</b>	ADESIVO USO PIATTAFORMA AEREA CINGOLATA - SVEDESE L= 128X230 MM <b>_MOD_C</b>	01
L2	073191SW	A	ADESIVO DISCESA DI EMERGENZA LL 1775/200 MOTORE TERMICO E LITHIUM - SWE L=290X205 MM	01
	177764PT		ADESIVI PIATTAFORMA AEREA X17JPLUS MK2 - LINGUA PORTOGHESE	
L1	06563100	<b>C</b>	ADESIVO USO PIATTAFORMA AEREA CINGOLATA - PORTOGHESE L=128X230 <b>_MOD_C</b>	01
L2	073191PT	A	ADESIVO DISCESA DI EMERGENZA LL 1775/200 MOTORE TERMICO E LITHIUM - OLA L=290X205 MM	01
	177764DA		ADESIVI PIATTAFORMA AEREA X17JPLUS MK2 - LINGUA DANESE	
L1	07138100	<b>C</b>	ADESIVO USO PIATTAFORMA AEREA CINGOLATA - DANESE L= 128X230 MM <b>_MOD_C</b>	01
L2	073191DA	A	ADESIVO DISCESA DI EMERGENZA LL 1775/200 MOTORE TERMICO E LITHIUM - DAN L=290X205 MM	01
	177764NO		ADESIVI PIATTAFORMA AEREA X17JPLUS MK2 - LINGUA NORVEGESE	
L1	07162000	<b>C</b>	ADESIVO USO PIATTAFORMA AEREA CINGOLATA - NORVEGESE L=128X230 MM <b>_MOD_C</b>	01
L2	073191NO	A	ADESIVO DISCESA DI EMERGENZA LL 1775/200 MOTORE TERMICO E LITHIUM - NOR L=290X205 MM	01
	177764RU		ADESIVI PIATTAFORMA AEREA X17JPLUS MK2 - LINGUA RUSSO	
L1	07514800	A	ADESIVO USO PIATTAFORMA AEREA CINGOLATA - RUSSO L=128X230 MM	01
L2	073191RU	A	ADESIVO DISCESA DI EMERGENZA LL 1775/200 MOTORE TERMICO E LITHIUM - RUSSO L=290X205 MM	01
	177764PL		ADESIVI PIATTAFORMA AEREA X17JPLUS MK2 - LINGUA POLACCO	
L1	07506600	<b>B</b>	ADESIVO USO PIATTAFORMA AEREA CINGOLATA - POLACCO L= 128X230 MM <b>_MOD_B**</b>	01
L2	073191PL	A	ADESIVO DISCESA DI EMERGENZA LL 1775/200 MOTORE TERMICO E LITHIUM - POL L=290X205 MM	01







**KIT ADESIVI SICUREZZA PIATTAFORMA AEREA /  
*AERIAL PLATFORM KIT STICKERS SAFETY*  
JLG/ANSI - X500AJ - MK2**

**Cod. 17776800**

**+ kit in lingua non inclusi nel codice generale / *language code not included in the standard kit***

**177768GB - 177768FR - 177768ES - 177768PT**

**DA USARE CON / *FOR USE WITH***  
**17224200 KIT ADESIVI COMMERCIALI PIATTAFORMA AEREA X500AJ ANSI /  
*STICKERS KIT COMMERCIAL AERIAL PLATFORM***

**17107300 KIT ADESIVI INTEGRZIONE PER PIATTAFORME AEREE JLG-ANSI LITHIUM /  
*STICKER KITS FOR INTEGRATION PLATFORMS JLG-ANSI LITHIUM /***  
**X370AJ • X390AJ • X430AJ • X500AJ • X550AJ • X600AJ • X700AJ • X770AJ**

**• 171073\*\* KIT IN LINGUA / *KIT IN LANGUAGE***



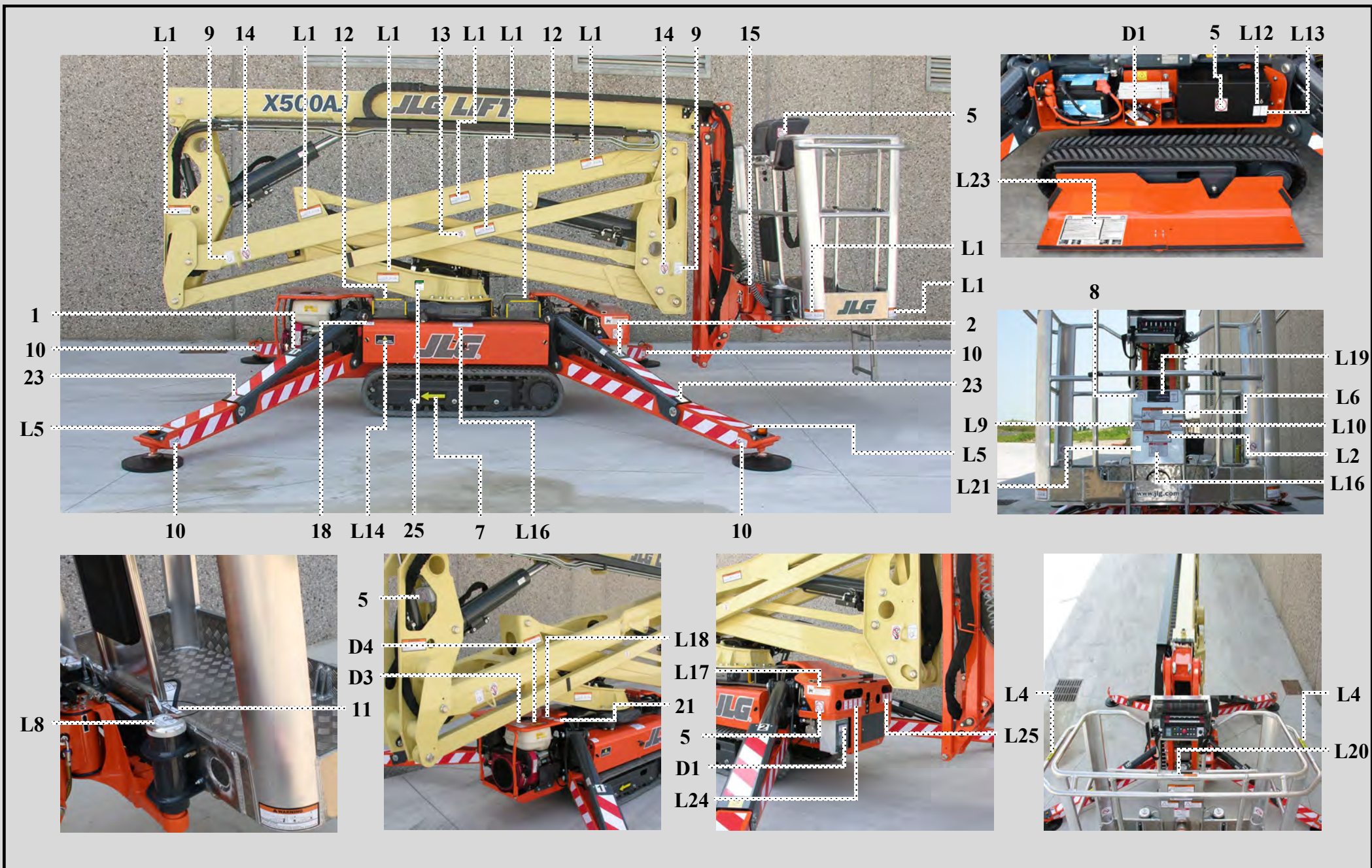

KIT ADESIVI - X500AJ - MK2	AUFKLEBERSATZ - X500AJ - MK2	<b>Cod. 17776800</b>
SET OF DECALS - X500AJ - MK2	KIT ADHESIVOS - X500AJ - MK2	
KIT COLLANTS - X500AJ - MK2	ADHESIEKIT - X500AJ - MK2	<b>Tav 01</b>

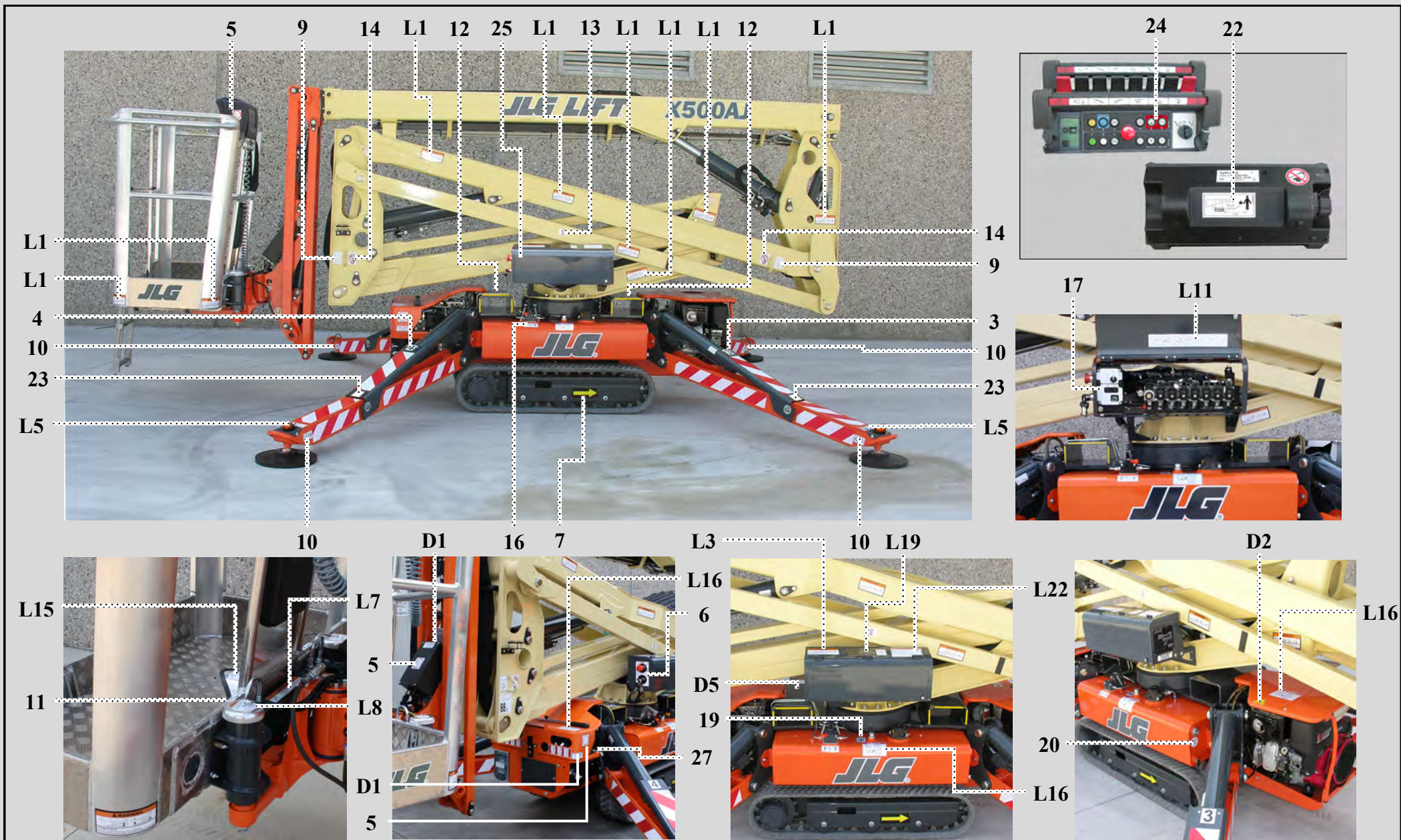

KIT ADESIVI - X500AJ - MK2	AUFKLEBERSATZ - X500AJ - MK2	<b>Cod. 17776800</b>
SET OF DECALS - X500AJ - MK2	KIT ADHESIVOS - X500AJ - MK2	
KIT COLLANTS - X500AJ - MK2	ADHESIEKIT - X500AJ - MK2	<b>Tav 02</b>

**JLG/ANSI - X500AJ - MK2 COD. 17776800 POSIZIONE ADESIVI / POSITION STICKERS**

**JLG**

POSIZIONE	CODICE	REV.	DESCRIZIONE	QUANTITA'
01	06555500	A	ADESIVO NR 1 L=50X60 BIANCO	01
02	06555600	A	ADESIVO NR 2 L=50X60 BIANCO	01
03	06555700	A	ADESIVO N° 3 L=50X60 BIANCO	01
04	06555800	A	ADESIVO N° 4 L=50X60 BIANCO	01
05	1001125483	A	ADESIVO JLG VIETATO LAVARE L=63,5X63,5 MM	06
06	07668200	<b>B</b>	ADESIVO EMERGENCY STOP E BLOCCHETTO ACCENSIONE L=85x160 MM <b>_MOD_B</b>	01
07	06040500	A	ADESIVO DIREZ. TRASLAZIONE FRECCIA GIALLA SFONDO NERO L=61 X 160	02
08	1701640	A	ADESIVO JLG LEGGERE IL MANUALE L= 69,85x69,85 MM	01
09	1703814	A	ADESIVO JLG ATTACCO ANCORAGGIO L=55,56X76,2 MM	04
10	07071200	A	ADESIVO JLG PUNTO DI SOLLEVAMENTO L= 40X66 MM	08
11	1704277	A	ADESIVO JLG ATTACCO CINTURE DI SICUREZZA L= 76,2X19,05 MM	02
12	07350300	A	ADESIVO SOLLEVAMENTO PIATTAFORMA CON MULETTO L=90X70 MM	04
13	07056700	A	ADESIVO JLG DIVIETO DI SOLLEVAMENTO L=40X54,88	02
14	1701499	A	ADESIVO JLG DIVIETO DI SOLLEVAMENTO DAL PUNTO DI ANCORAGGIO L= 55,56X76 MM (**)	04
15	06706500	A	ADESIVO ALLINEAMENTO CESTO (2 PEZZI) L=16X50+13	01
16	06998800	A	ADESIVO DEVIATORE POMPA MANUALE PIATTAFORMA GL17.80XL L=86X34	01
17	07668300	A	ADESIVO SELETTORE SCATOLA COMANDI TERRA / CESTO L=105X155 MM	01
18	1702155	A	ADESIVO JLG STACCABATTERIA L= 63,5X50,80 MM	01
19	1701504	A	ADESIVO JLG OLIO IDRAULICO L=50,8x63,5 MM	01
20	06165000	A	ADESIVO LIVELLO OLIO IDRAULICO Ø50 SFONDO BIANCO	01
21	06060000	A	ADESIVO LIVELLO OLIO MOTORE Ø50mm	01
22	07240300	<b>B</b>	ADESIVO DISTANZA 1 METRO SU TELE/RADIO COMANDI L= 75x35 MM <b>_MOD_B</b>	01
23	07242100	<b>B</b>	ADESIVO REAZIONE AL SUOLO STABILIZZATORI X500AJ L= 50X50 - BIANCO <b>_MOD_B</b>	04
24	07071000	<b>B</b>	ADESIVO JLG CLAXON SU PIATTAFORME L=39,3X28,55 MM <b>_MOD_B</b>	01
25	1001223055	A	ADESIVO JLG INSPEZIONE ANNUALE RICHIESTA	01
26	/	/	/	/





**JLG/ANSI - X500AJ - MK2 COD. 177768\*\* ADESIVI IN LINGUA / ADHESIVES IN LANGUAGE**

**JLG**

POS.	CODICE				DESCRIZIONE	Q.TA'
	177768FR	177768PT	177768ES	177768GB	KIT ADESIVI SICUREZZA PIATTAFORMA AEREA X500AJ JLG/ANSI LINGUA INGLESE	
L1	07116800	07121400		07056100	ADESIVO JLG PERICOLO SCHIACCIAMENTO - ING L= 140x60,71 MM	14
L2	07119100	07123700		1706387	ADESIVO JLG PERICOLO SCHIACCIAMENTO - ING L=177,80x69,85 MM ( SUL CESTO )	01
L3	07118500	07123100		1706099	ADESIVO JLG PERICOLO SCHIACCIAMENTO - ING L= 161,925X69,85 MM ( A TERRA )	01
L4	07117800	07122400		1702868_B	ADESIVO JLG PERICOLO SCHIACCIAMENTO MANO - ING L= 241,30X25.40 MM (CESTO)_MOD_B	02
L5	07116900	07121500		07056200	ADESIVO JLG ATTACCO SCHIACCIAMENTO ARTO INFERIORE - ING L= 110x60 (PRES. STABILIZZ.)	04
L6	07119000	07123600		1706386	ADESIVO JLG PERICOLO CADUTE - ING L=196,85x76,2 MM	01
L7	07116700	07121300		07051100_B	ADESIVO JLG PERICOLO CADUTA - RIPRISTINARE I TAPPI - ING L=196,5x35 MM )_MOD_B	01
L8	07116600	07121200		07051000	ADESIVO JLG ATTENZ.CADUTE - SBLOCCARE SOLO NEI CASI PREVISTI - ING D Ø 60 FORO 4 MM (**)	02
L9	07118700	07123300		1706133_C	ADESIVO JLG PERICOLO RIBALTAMENTO - ING L=139,7X68,85 MM )_MOD_C	01
L10	07117200	07121800		07058600	ADESIVO JLG POSIZIONE STABILIZZATORI X390 - X550 - ING L=139,7X69,85 MM	01
L11	076787FR	076787PT		076787GB	ADESIVO JLG ANSI PULSANTI DISTRIBUTORE PARTE AEREA X770AJ - ING L=318X52 MM	01
L12	07115200	07119800		07042100	ADESIVO JLG SISTEMA BYPASS PARTE AEREA - ING L=30X50 (**)	01
L13	07115300	07119900		07042200	ADESIVO JLG SISTEMA BYPASS TRASLAZIONE - ING L= 30X50 (**)	01
L14	07117900	07122500		1702901	ADESIVO JLG ISTRUZIONI DISCESA EMERGENZA / POMPA MANUALE - ING L=114,3x58,73MM	01
L15	07119200	07123800		3252347_B	ADESIVO JLG ATTENZIONE PEDALE - ING L= 69,85x57,15 MM MOD_B	01
L16	07118600	07123200		1706128_E	ADESIVO JLG PERICOLO FOLGORAZIONE - ING L=120,65x91,50 MM MOD_E	05
L17	07118200	07122800		1703813	ADESIVO JLG PERICOLO ESPLOSIONE BATTERIE - ING L=149,25X47,62 MM	01
L18	07118300	07122900		1704972_C	ADESIVO JLG PERICOLO ESPLOSIONE - ING L=63,5x92,07 MM )_MOD_C	01
L19	081081FR	081081PT		081081GB	ADESIVO JLG/ ANSI CARICO MAX IN CESTA X1000AJ - L=196, 85x76,2 MM	02
L20	07118900	07123500		1706385_C	ADESIVO JLG SCORRIMENTO SBARRA CHIUSURA CESTO - ING L=184,15X25,4 MM )_MOD_C	01
L21	08069800	08069800		08069800	ADESIVO JLG ATTENZIONE PROP.65 L=101,6X57,1 MM RIF JLG CODE. 1001231801C	01
L22	07118800	07123400		1706135_B	ADESIVO JLG USO PIATTAFORMA - ING L=139,70x88,90 MM )_MOD_B	01
L23	072422FR	072422PT		072422GB	ADESIVO JLG ANSI ISTRUZIONI DISCESA DI EMERG. X500AJ - ING L=290X205 MM	01
L24	072425FR	072425PT		072425GB	ADESIVO JLG ANSI PULSANTI DISTRIBUTORI A TERRA LATO SX X500AJ - ING L=194X50 MM	01
L25	072426FR	072426PT		072426GB	ADESIVO JLG ANSI PULSANTI DISTRIBUTORI A TERRA LATO DX X500AJ - ING L=150X50 MM	01
	000000FR	000000PT		076358GB	ADESIVO JLG ANSI CARICO MAX IN CESTA 1 PERSONA X500AJ-X600AJ-X770AJ / ING L=196,85x76,2 MM - NON IN DISTINTA	01



KIT INTEGRAZIONE ADESIVI  
CESTO RETTANGOLARE DSE

DECALS KIT INTEGRATION  
RECTANGULAR DSE BASKET

18374500

# HISTORY REVISION

DATA/DATE	VERSION	MODIFICHE/CHANGES	AUTORE
01/04/2021	1.0	Realizzata nuova versione senza foto. New version without photos.	Masaggia Mattia

**LISTA ADESIVI**  
**DECALS LIST**

<b>CODE</b>	<b>DESCRIZIONE</b>	<b>QTA'</b>
07058800	ADESIVO PERICOLO MANTENERE LE DISTANZE L=65X130 MM - GIALLO	2,00
08141300	ADESIVO NEW LOGO HINOWA GRAFFIATO H=40mm L=100mm	1,00
08347400	ADESIVO STRISCIA BIANCA E ROSSA H100 X L220 MM	2,00
08347500	ADESIVO STRISCIA BIANCA E ROSSA H100 X L350 MM	2,00
08318500	ADESIVO PRESPAZIATO CESTO DSE NERO	1,00

VEDI  
MODELLO  
MACCHINA

06040900

07878400

06040400

VEDI  
MODELLO  
MACCHINA

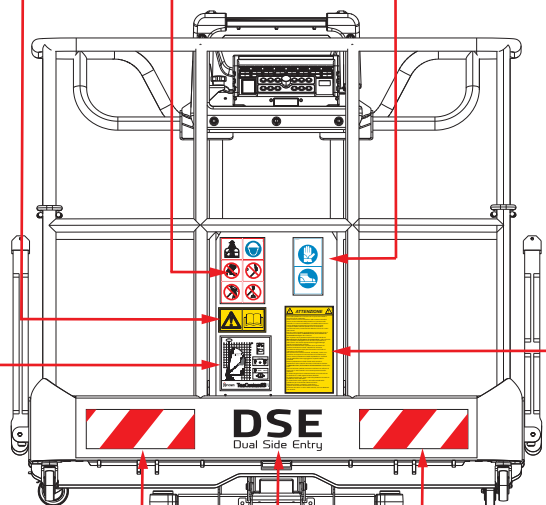

08347500

08318500

08347500

08141300

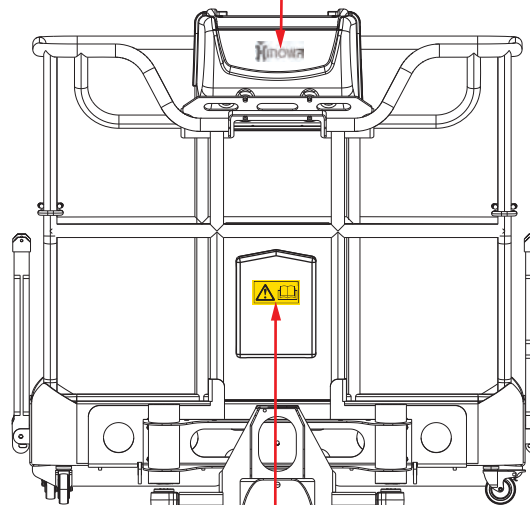

06040900

06448100

06448200



06448200

06448100

1001125483

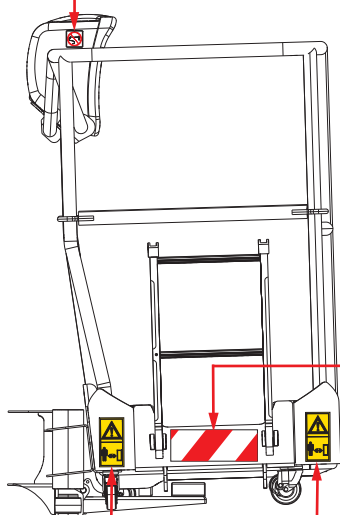

07058800

1001125483

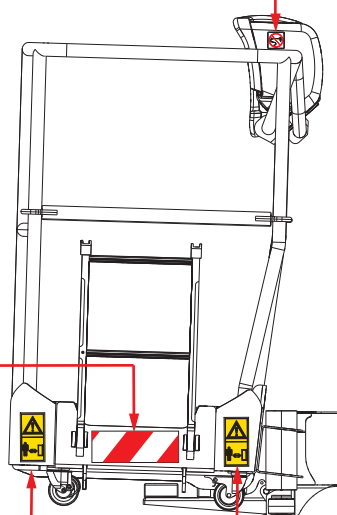

07058800

08347400

1704277

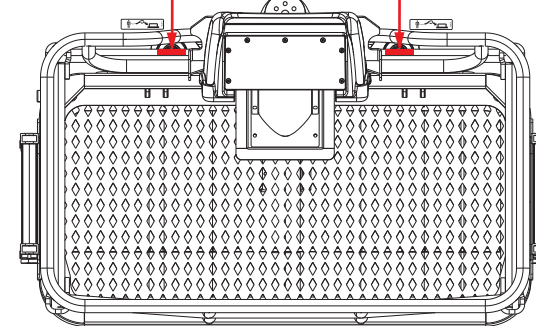

1704277

KIT INTEGRAZIONE ADESIVI  
CESTO RETTANGOLARE DSE ANSI

DECALS INTEGRATION KIT  
DSE RECTANGULAR BASKET ANSI

**18486500**

# HISTORY REVISION

<b>DATA/DATE</b>	<b>VERSION</b>	<b>MODIFICHE/CHANGES</b>	<b>AUTORE</b>
24/01/2022	1.0	Realizzato nuovo KIT New KIT made	Masaggia Mattia

**LISTA ADESIVI IN KIT CODE. 18486500****DECALS LIST KIT CODE 18486500**

POS	CODE			DESCRIZIONE DESCRIPTION	QTA QTY
	ENGLISH	FRENCH	PORTUGUESE		
L20	1706385	07118900	07123500	ADESIVO JLG SCORRIMENTO SBARRA CHIUSURA CESTO - ING L=184,15X25,4 MM_MOD_C	01

CODE	DESCRIPTION	QTY
1701640	ADESIVO JLG LEGGERE IL MANUALE L= 69,85x69,85 MM	01
08347500	ADESIVO STRISCIA BIANCA E ROSSA H100 X L350 MM	02
08347400	ADESIVO STRISCIA BIANCA E ROSSA H100 X L220 MM	02
07690100	ADESIVO JLG - LOGO JLG PER CESTO COLORE GRIGIO PANTONE 432C L=300x104,2 MM	01

LISTA ADESIVI CESTO COMPLETO COMPLETE BASKET DECALS LIST						
POS	CODE			DESCRIZIONE DESCRIPTION	QTA QTY	
	ENGLISH	FRENCH	PORTUGUESE			
L1	07056100	07116800	07121400	ADESIVO JLG PERICOLO SCHIACCIAMENTO - ING L= 140x60,71 MM	04	
L2	1706387	07119100	07123700	ADESIVO JLG PERICOLO SCHIACCIAMENTO - ING L=177,80x69,85 MM ( SUL CESTO )	01	
L4	1702868	07117800	07122400	ADESIVO JLG PERICOLO SCHIACCIAMENTO MANO - ING L= 241,30X25.40 MM_MOD_B (**)	01	
L6	1706386	071190000	07123600	ADESIVO JLG PERICOLO CADUTE - ING L=196,85x76,2 MM	01	
L7	07051100	07116700	07121300	ADESIVO JLG PERICOLO CADUTA - RIPRISTINARE I TAPPI - ING L=196,5x35 MM_MOD_B	01	
L8	07051000	07116600	07121200	ADESIVO JLG ATTENZ.CADUTE - SBLOCCARE SOLO NEI CASI PREVISTI - ING D Ø 60 FORO 4 MM (**)	02	
L9	1706133	07118700	07123300	ADESIVO JLG PERICOLO RIBALTAMENTO - ING L=139,7X68,85 MM_MOD_C	01	
L10	07058600	07117200	07121800	ADESIVO JLG POSIZIONE STABILIZZATORI X700 - ING L=139,7X68,85 MM	01	
L16	1706128	07118600	07123200	ADESIVO JLG PERICOLO FOLGORAZIONE - ING L=120,65x91,50 MM_MOD_E	01	
L19	081081GB	081081FR	081081PT	ADESIVO JLG/ANSI CARICO MAX IN CESTA 2 PERSONE X1000AJ - ING L=196,85x76,2 MM (INGLESE)	01	
L20	1706385	07118900	07123500	ADESIVO JLG SCORRIMENTO SBARRA CHIUSURA CESTO - ING L=184,15X25,4 MM_MOD_C	02	
L21	08069800			ADESIVO JLG ATTENZIONI PROP.65 L=101,6x57,1 MM RIF JLG CODE. 1001231801 C	01	

ADESIVI NON IN LINGUA / DECALS NOT IN LANGUAGE		
CODE	DESCRIPTION	QTY
1701640	ADESIVO JLG LEGGERE IL MANUALE L= 69,85x69,85 MM	02
08347500	ADESIVO STRISCIA BIANCA E ROSSA H100 X L350 MM	02
08347400	ADESIVO STRISCIA BIANCA E ROSSA H100 X L220 MM	02
1704277	DECAL,LANYARD ATTACH	02
07690100	ADESIVO JLG - LOGO JLG PER CESTO COLORE GRIGIO PANTONE 432C L=300x104,2 MM	01
1001125483	ADESIVO JLG VIETATO LAVARE L=63,5X63,5 MM	02



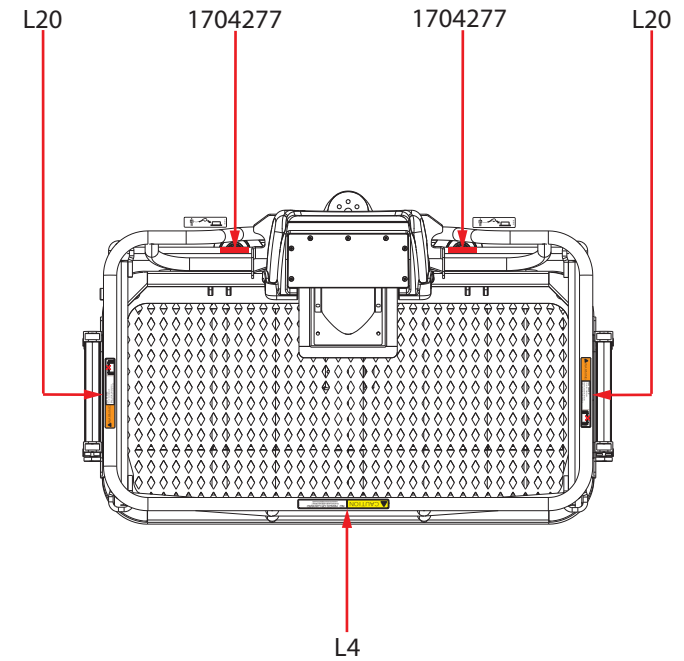
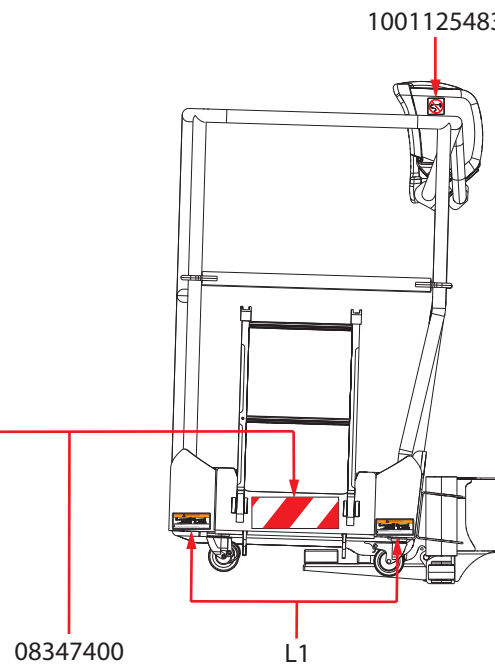
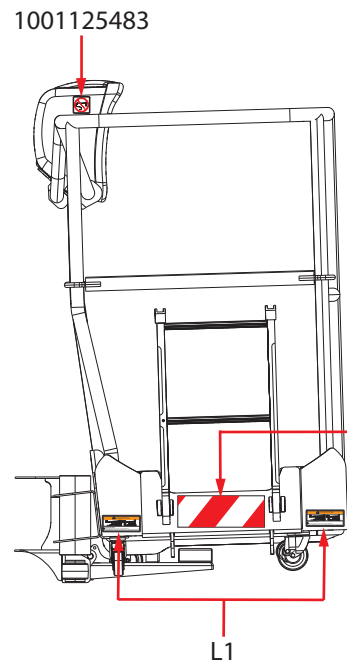
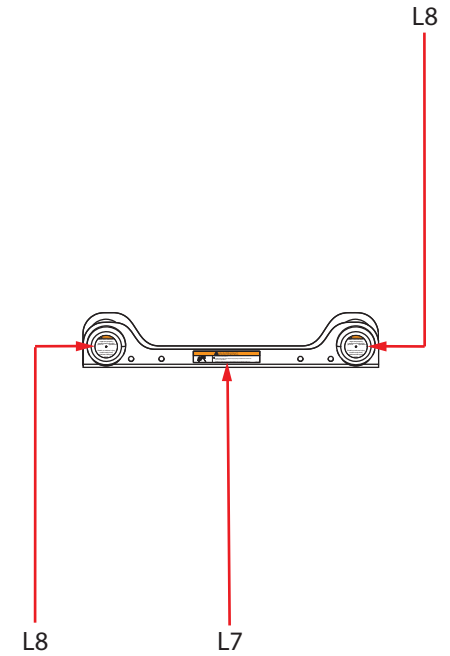
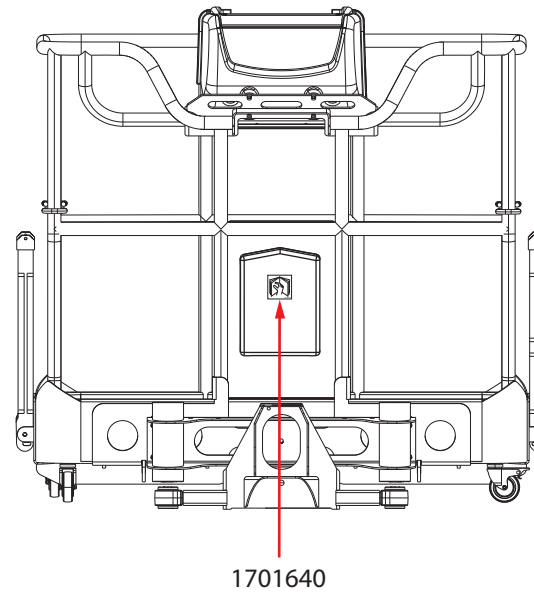
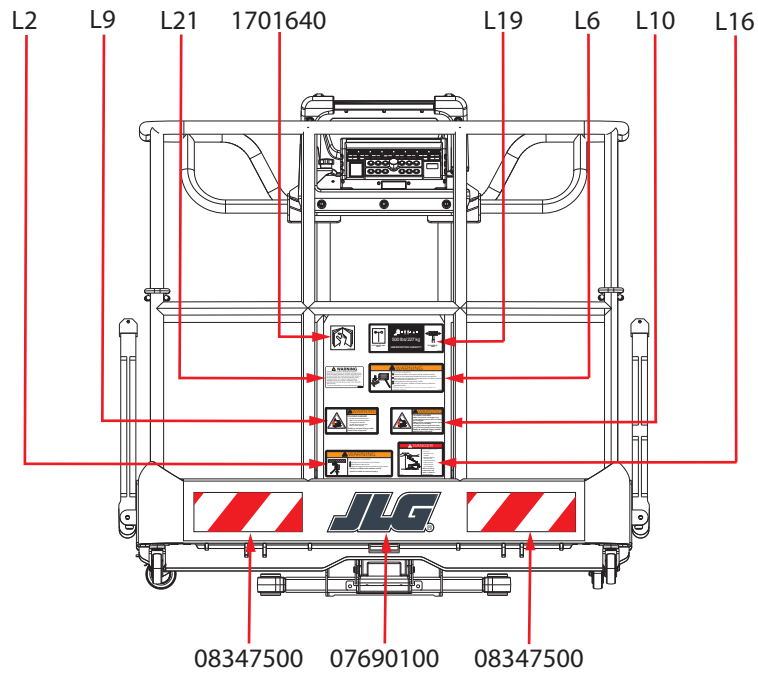



# TABELLA PERNI/SPINE (PINS TABLE)

LOCKING SYSTEM  
GHIERA  
(LOCKNUTS CODE)  
REF. TABLE BELOW

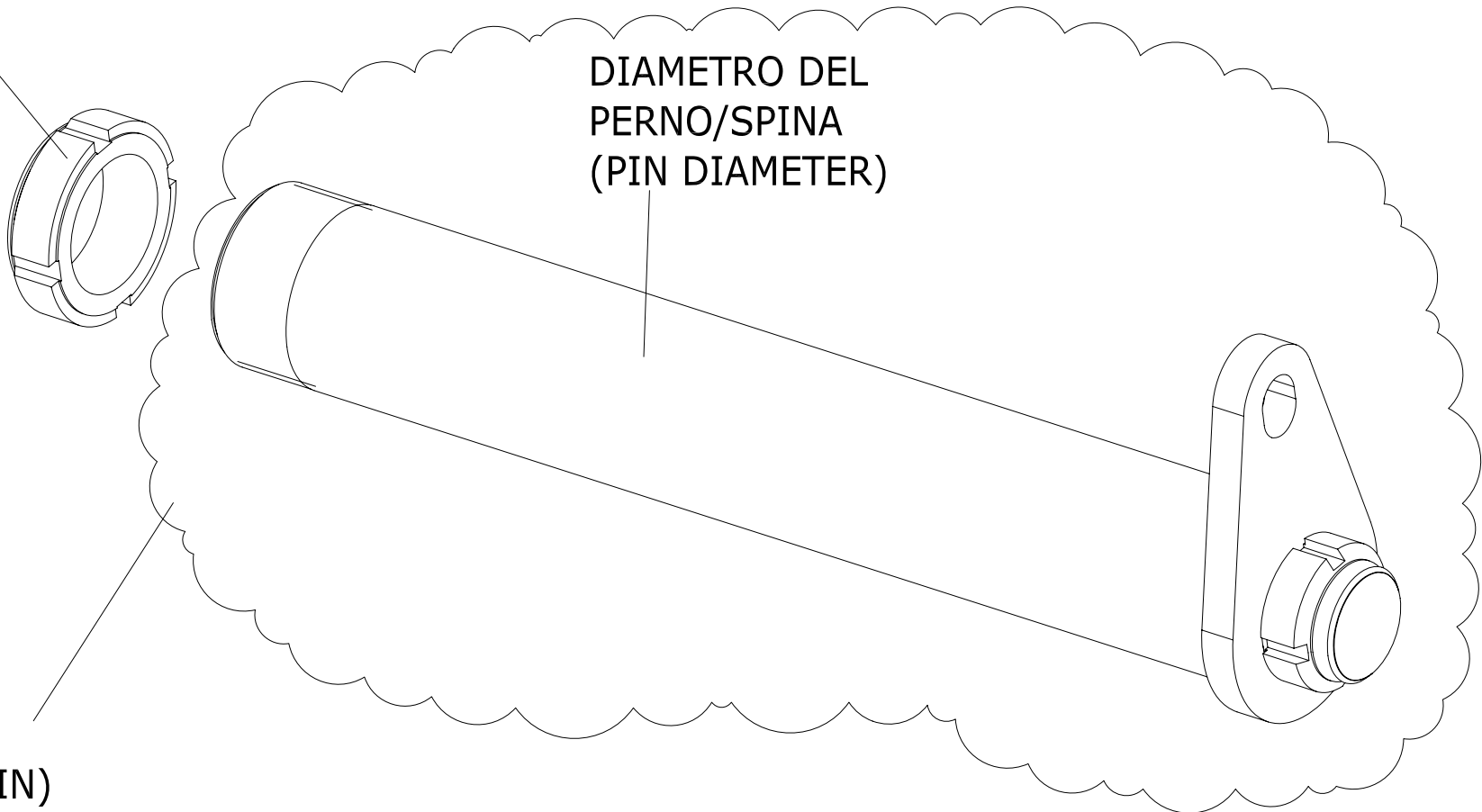

PERNO/SPINA (PIN)





IL CODICE DEL PERNO A RICAMBIO COMPRENDE LA GOCCIA MONTATA E LA GHIERA DI FISSAGGIO DELLA GOCCIA

THE CODE OF A PIN INCLUDES DROP PARTS MOUNTED AND THE LOCK NUT TO FIXING THE DROP, ALL THESE PARTS ARE SHIPPED ALREADY MOUNTED TOGETHER

<b>DIAMETRO DEL PERNO/SPINA mm SISTEMA METRICO (PIN DIAMETER mm METRIC)</b>	<b>GHIERA (LOCKNUTS CODE)</b>	<b>DADO (NUTS CODE)</b>
25	BG4	
30	BG5	
35	BG3	
40	BG2	
45	BG7	
50	BG8	
20 (DIAMETER OF THREADED PART M17 PITCH=1)	BG1	
20 (DIAMETER OF THREADED PART M20 PITCH=1)	BG6	
20 (DIAMETER OF THREADED PART M20 PITCH=1,5)	BG12	

07825700 BUSSOLA PER GHIERE S12GU  
 07825800 BUSSOLA PER GHIERE S17GU  
 07825900 BUSSOLA PER GHIERE S20GU  
 07826000 BUSSOLA PER GHIERE S25GU  
 07826100 BUSSOLA PER GHIERE S30GU  
 07826200 BUSSOLA PER GHIERE S35GU  
 07826300 BUSSOLA PER GHIERE S40GU  
 07826400 BUSSOLA PER GHIERE S45GU  
 07826500 BUSSOLA PER GHIERE S50GU  
 07826600 BUSSOLA PER GHIERE S55GU  
 07826700 BUSSOLA PER CHIÈRE S65GU

POS	Codice	U.M.	 Descrizione	 Description	 Designation	 Benennung	 Descripción
BC1	BC000100	NR	COPPIGLIA 4X40	COTTER PIN 4X40	GOUPILLE 4X40	SPLINT 4X40	CLAVIJA 4X40
BC2	BC000200	NR	COPPIGLIA 5X40	COTTER PIN 5X40			
BC3	BC000300	NR	SEEGER ESTERNO Ø20 GEOMET	SEEGER EXTERNAL Ø20 GEOMET	SEGER EXTERNE Ø20 GEOMET	EXTERNEN SEGER Ø20 GEOMET	SEGER ESTERNO Ø20 GEOMET
BC4	BC000400	NR	SEEGER ESTERNO Ø8	SEEGER EXTERNAL Ø8	CIRCLIP	RING	ANILLO
BC5	BC000500	NR	SEEGER ESTERNO Ø25 GEOMET	SEEGER EXTERNAL Ø25 GEOMET	SEEGER CIRCLIP	SEEGERRING	ANILLO DE RETENCIÓN SEEGER
BC6	BC000600	NR	COPPIGLIA 1,8X8	COTTER PIN 1,8X8			
BC7	BC000700	NR	COPPIGLIA 4X55	COTTER PIN 4X55	GOUPILLE 4X55	SPLINT 4X55	CLAVIJA 4X55
BC8	BC000800	NR	SEEGER ESTERNO Ø15	SEEGER EXTERNAL Ø15	CIRCLIP	RING	ANILLO
BC9	BC000900	NR	SEEGER ESTERNO Ø30	SEEGER EXTERNAL Ø30	CIRCLIP	RING	ANILLO
BC11	BC001100	NR	ANELLI ELASTICI X ALBERI (SEEGER) DIN 471 ACC.MOLLE 10 ZINCATA D. BIANCA	SNAP RINGS FOR SHAFTS (SEEGER) DIN 471 ACC. SPRINGS 10 Z WITHE	CIRCLIP	RING	ANILLO
BC12	BC001200	NR	ANELLI ELASTICI X ALBERI (SEEGER) DIN 471 ACC.MOLLE 12 GEO 321A	SNAP RINGS FOR SHAFTS (SEEGER) DIN 471 ACC. SPRINGS 12 GEO 321A	CIRCLIP	RING	ANILLO
BC13	BC001300	NR	ANELLI ELASTICI X FORI (SEEGER) DIN 472 ACC.MOLLE 33 GEO 321A	SNAP RINGS FOR HOLES (SEEGER) DIN 472 ACC. SPRINGS 33 GEO 321A	CIRCLIP	RING	ANILLO
BC14	BC001400	NR	ANELLI ELASTICI X FORI (SEEGER) DIN 472 ACC.MOLLE 62 GEO 321A	SNAP RINGS FOR HOLES (SEEGER) DIN 472 ACC. SPRINGS 62 GEO 321A	CIRCLIP	RING	ANILLO
BC15	BC001500	NR	ANELLI ELASTICI X FORI (SEEGER) DIN 472 ACC.MOLLE 75 GEO 321A	SNAP RINGS FOR HOLES (SEEGER) DIN 472 ACC. SPRINGS 75 GEO 321A	CIRCLIP	RING	ANILLO
BC16	BC001600	NR	COPIGLIA RICOTTA DIN 94 FERRO RICOTTO D 5 X 70 Z.BIANCA	COTTER PIN DIN 94 IRON ANNEALED D 5 X 70 Z. WHITE	CIRCLIP	RING	ANILLO

POS	Codice	U.M.	 Descrizione	 Description	 Designation	 Benennung	 Descripción
BC17	BC001700	NR	COPIGLIA ELASTICA DI SICUREZZA ACC.MOLLE D 2 Z.BIANCA	ELASTIC COTTER PIN ACC. SPRINGS D 2 Z. WHITE	CIRCLIP	RING	ANILLO
BC18	BC001800	NR	ANELLI ELASTICI X ALBERI (SEEGER) DIN 471 ACC.MOLLE 35 GEO 321A	SNAP RINGS FOR SHAFTS (SEEGER) DIN 471 ACC. SPRINGS 35 GEO 321A	CIRCLIP	RING	ANILLO
BC19	BC001900	NR	ANELLI ELASTICI X ALBERI (SEEGER) DIN 471 ACC.MOLLE 70 GEO 321A	SNAP RINGS FOR SHAFTS (SEEGER) DIN 471 ACC. SPRINGS 70 GEO 321A	CIRCLIP	RING	ANILLO
BC20	BC002000	NR	COPIGLIA RICOTTA DIN 94 FERRO RICOTTO D 5 X 50 Z.BIANCA	COTTER PIN DIN 94 IRON ANNEALED D 5 X 50 Z. WHITE	CIRCLIP	RING	ANILLO
BC21	BC002100	NR	ANELLI ELASTICI X FORI (SEEGER) DIN 472 ACC.MOLLE 55 GEO 321A	SNAP RINGS FOR HOLES (SEEGER) DIN 472 ACC. SPRINGS 55 GEO 321A	CIRCLIP	RING	ANILLO
BD1	BD000100	NR	DADO ESAGONALE FLANGIATO LISCIO PG DIN 6923 CL 8 M 14 Z.BIANCA	HEX FLANGE NUT DIN 6923 CL SMOOTH PG 8 M 14 Z. WHITE	ÉCROU HEXAGONAL BRIDÉ LISSE PG DIN 6923 CL 8 M 14 Z.BLANCHE	GEWINDE SECHSKANTMUTTER DIN 6923 CL SMOOTH PG 8 M 14 Z. WEIß	ARANDELA HEXAGONAL ROSCADA LISA DIN 6923 CL 8 M 14 GALVANIZADA BLANCA
BD2	BD000200	NR	DADO ESAGONALE BASSO PG DIN 936 CL 04 M 8 Z.BIANCA	LOW HEX NUT DIN 936 PG 04 M CL 8 Z. WHITE	ÉCROU HEXAGONAL BAS PG DIN 936 CL 04 M 8 GALVANISÉ BLANC	NUTTER	TUERCA
BD3	BD000300	NR	DADO ESAGONALE ALTO PG UNI 5587 CL 8 M 8 Z.BIANCA	HEX NUT HIGH PG UNI 5587 CL 8 M 8 Z. WHITE	ÉCROU HEXAGONAL PG UNI 5587 CL 8 M 8 Z.BLANCHE	HOHE SECHSKANTMUTTER PG UNI 5587 CL 8 M 8 Z. WEIß	ARANDELA ALTA HEXAGONAL UNI 5587 CL 8 M 8 GALVANIZADA BLANCA
BD4	BD000400	NR	DADO ALTO AUTOBLOCCANTE PG DIN 982 CL 8 M 12 Z.BIANCA	HIGH SELF LOCKING NUT DIN 982 PG 12 CL 8 M Z. WHITE	HAUT ÉCROU AUTOBLOQUANT DIN 982 PG 12 CL 8 M Z. BLANCHE	HOHE SELBSTSICHERUNGSMUTTER DIN 982 PG 12 CL 8 M Z. WEIß	ARANDELA ALTA AUTOBLOCANTE DIN 982 CL 8 M 12 GALVANIZADA BLANCA
BD5	BD000500	NR	DADO ALTO AUTOBLOCCANTE PG DIN 982 CL 8 M 8 Z.BIANCA	HIGH SELF LOCKING NUT DIN 982 PG CL 8 M 8 Z. WHITE	HAUT ÉCROU AUTOBLOQUAND DIN 982 PG CL 8 M 8 Z. BLANCHE	HOHE SELBSTSICHERUNGSMUTTER DIN 982 PG CL 8 M 8 Z. WEIß	ARANDELA ALTA AUTOBLOCANTE DIN 982 CL 8 M 8 GALVANIZADA BLANCA
BD6	BD000600	NR	DADO ESAGONALE ALTO PG UNI 5587 CL 8 M 4 Z.BIANCA	HEX NUT HIGH PG UNI 5587 M 4 CL 8 Z. WHITE	ÉCROU HEXAGONAL HAUT PG UNI 5587 CL 8 M 4 GALVANISÉ BLANC	NUTTER	TUERCA





POS	Codice	U.M.	 Descrizione	 Description	 Designation	 Benennung	 Descripción
BD7	BD000700	NR	DADO ESAGONALE BASSO PG DIN 936 CL 04 M 6 Z.BIANCA	LOW HEX NUT DIN 936 PG 6 CL 04 M Z. WHITE	ÉCROU BAS HEXAGONAL DIN 936 PG 6 CL 04 M Z. BLANCHE	NIEDRIGE SECHSKANTMUTTER DIN 936 PG 6 CL 04 M Z. WEIß	ARANDELA BAJA HEXAGONAL DIN 936 CL 04 M 6 GALVANIZADA BLANCA
BD8	BD000800	NR	DADO BASSO AUTOBLOCCANTE PG DIN 985 CL 8 M 6 Z.BIANCA	LOW SELF-LOCKING NUT DIN 985 PG 6 CL 8 M Z. WHITE	ÉCROU BAS AUTOBLOQUANT DIN 985 PG 6 CL 8 M Z. BLANCHE	NIEDRIGE SELBSTSICHERUNGSMUTTER DIN 985 PG 6 CL 8 M Z. WEIß	ARANDELA BAJA AUTOBLOCANTE DIN 985 CL 8 M 6 GALVANIZADA BLANCA
BD9	BD000900	NR	DADO ALTO AUTOBLOCCANTE PG DIN 982 CL 8 M 6 Z.BIANCA	HIGH SELF LOCKING NUT DIN 982 PG CL 8 M6 Z. WHITE	ÉCROU HAUT AUTOBLOQUANT NUT DIN 982 PG CL 8 M6 Z. BLANCHE	SELBSTSICHERUNGSMUTTER DIN 982 PG CL 8 M6 Z. WEIß	TUERCA AUTOBLOCANTE ALTA DIN 982 CL 8 M 6 GALVANIZADA BLANCA
BD10	BD001000	NR	DADO BASSO AUTOBLOCCANTE PG DIN 985 CL 8 M 5 Z.BIANCA	LOW SELF-LOCKING NUT DIN 985 PG CL 8 M5 Z. WHITE	ÉCROU BAS AUTOBLOQUANT PG DIN 985 CL 8 M 5 GALVANISÉ BLANC	NUTTER	TUERCA
BD11	BD001100	NR	DADO ALTO AUTOBLOCCANTE PG DIN 982 CL 8 M 5 Z.BIANCA	HIGH SELF LOCKING NUT DIN 982 PG CL 8 M5 Z. WHITE	ÉCROU HAUT AUTOBLOQUANT PG DIN 982 CL 8 M 5 Z.BLANCHE	SELBSTSICHERUNGSMUTTER DIN 982 PG CL 8 M5 Z. WEIß	TUERCA AUTOBLOCANTE ALTA PG DIN 982 CL 8 M 5 GALVANIZADA BLANCA
BD12	BD001200	NR	DADO ALTO AUTOBLOCCANTE PG DIN 982 CL 8 M 4 Z.BIANCA	HIGH SELF LOCKING NUT DIN 982 PG CL 8 M4 Z. WHITE	ÉCROU HAUT AUTOBLOQUANT PG DIN 982 CL 8 M 4 Z.BLANCHE	SELBSTSICHERUNGSMUTTER DIN 982 PG CL 8 M4 Z. WEIß	TUERCA ALTA AUTOBLOCANTE PG DIN 982 CL 8 M 4 GALVANIZADO BLANCA
BD13	BD001300	NR	DADO ALTO AUTOBLOCCANTE PG DIN 982 CL 8 M 3 Z.BIANCA	HIGH SELF LOCKING NUT DIN 982 PG CL 8 M3 Z. WHITE	ÉCROU HAUT AUTOBLOQUANT PG DIN 982 CL 8 M 3 GALVANISÉ BLANC	NUTTER	TUERCA
BD14	BD001400	NR	DADO ALTO AUTOBLOCCANTE PF DIN 982 CL 8 M 20 X 1,5 Z.BIANCA	HIGH SELF LOCKING NUT DIN 982 PF CL 8 M 20 X 1.5 Z WHITE	ÉCROU HAUT AUTOBLOQUANT PF DIN 982 CL 8 M 20 X 1,5 Z.BLANCHE	SELBSTSICHERUNGSMUTTER DIN 982 PF CL 8 M 20 X 1.5 Z WEIß	TUERCA AUTOBLOCANTE ALTA DIN 982 CL 8 M 20 X 1,5 GALVANIZADA BLANCA
BD15	BD001500	NR	DADO ALTO AUTOBLOCCANTE PG DIN 982 CL 8 M 10 Z.BIANCA	HIGH SELF LOCKING NUT DIN 982 PG CL 8 M10 Z. WHITE	ÉCROU HAUT AUTOBLOQUANT DIN 982 PG CL 8 M10 Z. BLANCHE	SELBSTSICHERUNGSMUTTER DIN 982 PG CL 8 M10 Z. WEIß	TUERCA AUTOBLOCANTE ALTA DIN 982 CL 8 M 10 GALVANIZADA BLANCA
BD16	BD001600	NR	DADO ESAGONALE ALTO PG UNI 5587 CL 8 M 3 Z.BIANCA	HEX NUT HIGH PG UNI 5587 CL 8 M3 Z. WHITE	ÉCROU HEXAGONAL HAUT PG UNI 5587 CL 8 M 3 GALVANISÉ BLANC	NUTTER	TUERCA
BD17	BD001700	NR	DADO BASSO AUTOBLOCCANTE PG DIN 985 CL 8 M 8 Z.BIANCA	LOW SELF-LOCKING NUT DIN 985 PG CL 8 M8 Z. WHITE	ÉCROU BAS AUTOBLOQUANT PG DIN 985 CL 8 M 8 Z.BLANCHE	SELBSTSICHERUNGSMUTTER DIN 985 PG CL 8 M8 Z. WEIß	TUERCA BAJA AUTOBLOCANTE DIN 985 CL 8 M 8 GALVANIZADA BLANCA





POS	Codice	U.M.	 Descrizione	 Description	 Designation	 Benennung	 Descripción
BD18	BD001800	NR	DADO ALTO AUTOBLOCCANTE PG DIN 982 CL 8 M 16 Z.BIANCA	HIGH SELF LOCKING NUT DIN 982 PG CL 8 M16 Z. WHITE	ÉCROU AUTOBLOQUANT PG DIN 982 CL 8 M 16 GALVANISÉ BLANC	NUTTER	TUERCA
BD22	BD002200	NR	DADO ALTO AUTOBLOCCANTE PG DIN 982 CL 8 M 14 Z.BIANCA	HEX FLANGE NUT DIN 982 CL 8 M 14 Z. WHITE	ÉCROU HAUT AUTOBLOQUANT PG DIN 982 CL 8 M 14 Z.BLANCHE	SELBSTSICHERUNGSMUTTER DIN 982 CL 8 M 14 Z. WEIß	TUERCA ALTA AUTOBLOCANTE 982 CL 8 M 14 GALVANIZADA BLANCA
BD23	BD002300	NR	DADO BASSO AUTOBLOCCANTE PG DIN 985 CL 8 M 10 Z.BIANCA	LOW SELF-LOCKING NUT DIN 985 PG CL 8 M 10 Z. WHITE	ÉCROU BAS AUTOBLAQUANT PG DIN 985 CL 8 M 10 GALVANISÉ BLANC	NUTTER	TUERCA
BD24	BD002400	NR	DADO ALTO AUTOBLOCCANTE PG DIN 982 CL 8 M 24 Z.BIANCA	HIGH SELF LOCKING NUT DIN 982 PG CL 8 M24 Z. WHITE	ÉCROU HAUT AUTOBLOQUANT PG DIN 982 CL 8 M 24 GALVANISÉ BLANC	NUTTER	TUERCA
BD25	BD002500	NR	DADO ESAGONALE ALTO PG UNI 5587 CL 8 M 6 Z.BIANCA	HEX NUT HIGH PG UNI 5587 M 6 CL 8 Z. WHITE	ÉCROU HEXAGONAL HAUT PG UNI 5587 CL 8 M 6 Z.BLANCHE	SECHSKANTMUTTER PG UNI 5587 M 6 CL 8 Z. WEIß	TUERCA ALTA HEXAGONAL UNI 5587 CL 8 M 6 GALVANIZADA BLANCA
BD26	BD002600	NR	DADO ESAGONALE ALTO PG UNI 5587 CL 10 M 10 Z.BIANCA	HEX NUT HIGH PG UNI 5587 M 10 CL 10 Z. WHITE	ÉCROU HEXAGONAL HAUT PG UNI 5587 CL 10 M 10 Z.BLANCHE	SECHSKANTMUTTER PG UNI 5587 M 10 CL 10 Z. WEIß	TUERCA ALTA HEXAGONAL UNI 5587 CL 10 M 10 GALVANIZADA BLANCA
BD27	BD002700	NR	DADO ALTO AUTOBLOCCANTE PG DIN 982 CL 8 M 18 Z.BIANCA	HIGH SELF LOCKING NUT DIN 982 PG CL 8 M18 Z. WHITE	ÉCROU HAUT AUTOBLOQUANT PG DIN 982 CL 8 M 18 Z.BLANCHE	SELBSTSICHERUNGSMUTTER DIN 982 PG CL 8 M18 Z. WEIß	TUERCA ALTA AUTOBLOCANTE DIN 982 CL 8 M 18 GALVANIZADA BLANCA
BD28	BD002800	NR	DADO BASSO AUTOBLOCCANTE PG DIN 985 CL 8 M 16 Z.BIANCA	LOW SELF-LOCKING NUT DIN 985 PG CL 8 M 16 Z. WHITE	ÉCROU BAS AUTOBLOQUANT PG DIN 985 CL 8 M 16 GALVANISÉ BLANC	NIEDRIGE SELBSTSICHERUNGSMUTTER DIN 985 PG CL 8 M 16 Z. WEIß	TUERCA BAJA AUTOBLOCANTE PG DIN 985 CL 8 M 16 GALVANIZADA BLANCA
BD29	BD002900	NR	DADO ESAGONALE ALTO PG UNI 5587 CL 8 M 5 Z.BIANCA	HEX NUT HIGH PG UNI 5587 M 5 CL 8 Z. WHITE	ÉCROU HEXAGONAL HAUT PG UNI 5587 CL 8 M 5 Z.BLANCHE	SECHSKANTMUTTER PG UNI 5587 M 5 CL 8 Z. WEIß	TUERCA ALTA HEXAGONAL UNI 5587 CL 8 M 5 GALVANIZADA BLANCA
BD30	BD003000	NR	DADO ESAGONALE ALTO PG UNI 5587 CL 12 M 5 Z.BIANCA	HEX NUT HIGH PG UNI 5587 M 5 CL 12 Z. WHITE	ÉCROU HEXAGONAL HAUT PG UNI 5587 CL 12 M 5 Z.BLANCHE	SECHSKANTMUTTER PG UNI 5587 M 5 CL 12 Z. WEIß	TUERCA ALTA HEXAGONAL UNI 5587 CL 12 M 5 GALVANIZADA BLANCA
BD31	BD003100	NR	DADO ESAGONALE ALTO PG UNI 5587 CL 16 M 5 Z.BIANCA	HEX NUT HIGH PG UNI 5587 M 5 CL 16 Z. WHITE	ÉCROU HEXAGONAL HAUT PG UNI 5587 CL 16 M 5 Z.BLANCHE	SECHSKANTMUTTER PG UNI 5587 M 5 CL 16 Z. WEIß	TUERCA ALTA HEXAGONAL UNI 5587 CL 16 M 5 GALVANIZADA BLANCA



POS	Codice	U.M.	 Descrizione	 Description	 Designation	 Benennung	 Descripción
BD32	BD003200	NR	DADO ALTO AUTOBLOCCANTE PG DIN 982 CL 8 M 20 Z.BIANCA	HIGH SELF LOCKING NUT DIN 982 PG CL 8 M20 Z. WHITE	ÉCROU HAUT AUTOBLOQUANT PG DIN 982 CL 8 M 20 GALVANISÉ BLANC	NUTTER	TUERCA
BD33	BD003300	NR	DADO BASSO AUTOBLOCCANTE PG DIN 985 CL 8 M 12 Z.BIANCA	LOW SELF-LOCKING NUT DIN 985 PG CL 8 M 12 Z. WHITE	ÉCROU BAS AUTOBLAQUANT PG DIN 985 CL 8 M 12 GALVANISÉ BLANC	NUTTER	TUERCA
BD35	BD003500	NR	DADO ESAGONALE ALTO PG UNI 5587 CL 10 M 12 Z.BIANCA	HEXAGON NUT ALTO UNI 5587 CL 10 M 12 Z. WHITE	ÉCROU	NUTTER	TUERCA
BD36	BD003600	NR	DADO ESAGONALE ALTO PG UNI 5587 CL 10 M 16 Z.BIANCA	HEXAGON NUT ALTO UNI 5587 CL 10 M 16 Z. WHITE	ÉCROU	NUTTER	TUERCA
BD37	BD003700	NR	DADO ESAGONALE ALTO PG UNI 5587 CL 8 M 20 Z.BIANCA	HEXAGON NUT ALTO UNI 5587 CL 8 M 20 Z. WHITE	ÉCROU	NUTTER	TUERCA
BD39	BD003900	NR	DADO ALTO AUTOBLOCCANTE PG DIN 982 CL 8 M 22 Z.BIANCA	HIGH SELF-LOCKING NUT DIN 982 CL 8 M 22 Z. WHITE	ÉCROU	NUTTER	TUERCA
BD40	BD004000	NR	DADO BASSO AUTOBLOCCANTE PG DIN 985 CL 8 M 14 Z.BIANCA	LOW SELF-LOCKING NUT DIN 985 CL 8 M 14 Z. WHITE	ÉCROU	NUTTER	TUERCA
BD41	BD004100	NR	DADO ESAGONALE MEDIO PF DIN 934 CL 10 M 16 X 1,5 Z.BIANCA	MEDIUM HEXAGONAL NUT PF DIN 934 CL 10 M 16 X 1.5 Z.BIANCA	ÉCROU HEXAGONAL	NUTTER	TUERCA
BD42	BD004200	NR	DADO ALTO PG DIN 982 CL 8 M 24 Z.BIANCA	HIGH NUT DIN 982 PG CL 8 M24 Z. WHITE	ÉCROU PG DIN 982 CL 8 M 24 GALVANISÉ BLANC	NUTTER	TUERCA
BD45	BD004500	NR	DADO ESAGONALE BASSO MB DIN439 INOX A2 M10 X 1	LOW NUT DIN439 INOX MB M10 X 1	ÉCROU BAS DIN439 INOX MB M10 X 1	NUTTER	TUERCA
BD46	BD004600	NR	DADO ALTO AUTOBLOCCANTE PG DIN 982 INOX A2 M4	NUT PG DIN 982 INOX A2 M4	ÉCROU PG DIN 982 INOX A2 M4	NUTTER	TUERCA
BG1	BG000100	NR	GHIERA AUTOBLOCCANTE GN CL 6 GN 3 D. 17 X 1 Z.BIANCA	SELF-LOCKING NUT GN GN 3 CL 6 D. 17 X 1 Z. WHITE			
BG2	BG000200	NR	GHIERA AUTOBLOCCANTE PESANTE CL 6 GUP 40 X 1,5 Z.BIANCA	SELF-LOCKING NUT HEAVY CL 6 GUP 40 X 1.5 Z WHITE			

POS	Codice	U.M.	 Descrizione	 Description	 Designation	 Benennung	 Descripción
BG3	BG000300	NR	GHIERA AUTOBLOCCANTE PESANTE CL 6 GUP 35 X 1,5 Z.BIANCA	SELF-LOCKING NUT HEAVY CL 6 GUP 35 X 1.5 Z WHITE			
BG4	BG000400	NR	GHIERA AUTOBLOCCANTE PESANTE CL 6 GUP 25 X 1,5 Z.BIANCA	SELF-LOCKING NUT HEAVY CL 6 GUP 25 X 1.5 Z WHITE	ÉCROU AUTO-BLOQUANT	SELBSTSICHERNDE NUTMUTTER	
BG5	BG000500	NR	GHIERA AUTOBLOCCANTE PESANTE CL 6 GUP 30 X 1,5 Z.BIANCA	SELF-LOCKING NUT HEAVY CL 6 GUP 30 X 1.5 Z WHITE	BAGUE AUTOBLOQUANT LOURDE CL 6 GUP 30 X 1,5 Z.BLANCHE	SELBSTSICHERUNGSNUTMUTTER CL 6 GUP 30 X 1.5 Z WEIß	CASQUILLO AUTOBLOCANTE CL 6 GUP 30 X 1,5 GALVANIZADO BLANCO
BG6	BG000600	NR	GHIERA AUTOBLOCCANTE PESANTE CL 6 GUP 20 X 1 Z.BIANCA	SELF-LOCKING NUT HEAVY CL 6 GUP 20 X 1 Z. WHITE	BAGUE AUTOBLOQUANTE CL 6 GUP 20 X 1 Z.BLANCHE	SELBSTSICHERUNGSNUTMUTTER CL 6 GUP 20 X 1 Z. WEIß	CASQUILLO AUTOBLOCANTE CL 6 GUP 20 X 1 GALVANIZADO BLANCO
BG7	BG000700	NR	GHIERA AUTOBLOCCANTE GN CL 6 GN 3 D. 45 X 1,5 Z.BIANCA	NUT	BAGUE	NUTMUTTER	TUERCA
BG8	BG000800	NR	GHIERA AUTOBLOCCANTE GN CL 6 GN 3 D. 50 X 1,5 Z.BIANCA	NUT	BAGUE	NUTMUTTER	TUERCA
BG9	BG000900	NR	GHIERA AUTOBLOCCANTE GN CL 6 GN 3 D. 20 X 1,5 Z.BIANCA	NUT	BAGUE	NUTMUTTER	TUERCA
BG10	BG001000	NR	GHIERA AUTOBLOCCANTE RIBASSATA CL 6 GUK 25 X 1,5 Z.BIANCA	SELF-LOCKING NUT LOWERED CL 6 GUK 25 X 1.5 Z.BIANCA	BAGUE	NUTMUTTER	TUERCA
BG11	BG001100	NR	GHIERA AUTOBLOCCANTE RIBASSATA CL 6 GUK 20 X 1 Z.BIANCA	SELF-LOCKING NUT LOWERED CL 6 GUK 20 X 1 Z.BIANCA	BAGUE	NUTMUTTER	TUERCA
BG12	BG001200	NR	GHIERA AUTOBLOCCANTE RIBASSATA CL 6 GUA 20 X 1.5 Z.BIANCA	SELF-LOCKING NUT LOWERED CL 6 GUA 20 X 1.5 Z.BIANCA	BAGUE	NUTMUTTER	TUERCA
BG13	BG001300	NR	GHIERA AUTOBLOCCANTE RIBASSATA CL 6 GUK 30 X 1.5 Z.BIANCA	SELF-LOCKING NUT LOWERED CL 6 GUK 30 X 1.5 Z.BIANCA	BAGUE	NUTMUTTER	TUERCA
BG14	BG001400	NR	GHIERA AUTOBLOCCANTE RIBASSATA CL 6 GUK 45 X 1.5 Z.BIANCA	SELF-LOCKING NUT LOWERED CL 6 GUK 45 X 1.5 Z.BIANCA	BAGUE	NUTMUTTER	TUERCA

POS	Codice	U.M.	 Descrizione	 Description	 Designation	 Benennung	 Descripción
BG15	BG001500	NR	GHIERA AUTOBLOCCANTE RIBASSATA CL 6 GUK 50 X 1.5 Z.BIANCA	SELF-LOCKING NUT LOWERED CL 6 GUK 50 X 1.5 Z.BIANCA	BAGUE	NUTMUTTER	TUERCA
BG16	BG001600	NR	GHIERA AUTOBLOCCANTE RIBASSATA CL 6 GUK 55 X 2 Z.BIANCA	SELF-LOCKING NUT LOWERED CL 6 GUK 55 X 2 Z.BIANCA	BAGUE	NUTMUTTER	TUERCA
BG17	BG001700	NR	GHIERA AUTOBLOCCANTE GN CL 6 GN 1 D. 12 X 1 Z.BIANCA	SELF-LOCKING NUT GN CL 6 GN 1 D. 12 X 1 Z. WHITE	BAGUE	NUTMUTTER	TUERCA
BG18	BG001800	NR	GHIERA AUTOBLOCCANTE GN CL 6 GN 3 D. 65 X 2 Z.BIANCA	NUT	BAGUE	NUTMUTTER	TUERCA
BI1	BI000100	NR	INSERTO ESAGONALE M6	INSERT HEX M6	INSERT FILETE M9 TETE REDUITE	GEWINDEINSERT M9 REDUZIERTER KOPF	INSERTO ROSCADO M9 CABEZA REDUCIDA
BI2	BI000200	NR	INSERTO ESAGONALE M5	INSERT HEX M5	INSERT FILETE M5 TETE REDUITE	GEWINDEINSERT M5 REDUZIERTER KOPF	INSERTO ROSCADO M5 CABEZA REDUCIDA
BI3	BI000300	NR	INSERTO CILINDRICO M4	INSERT M4			
BI4	BI000400	NR	INSERTO CILINDRICO M6	INSERT M6			
BI5	BI000500	NR	INSERTO ESAGONALE M8	INSERT HEX M8	INSERT FILETE M8 TETE REDUITE	GEWINDEINSERT M8 REDUZIERTER KOPF	INSERTO ROSCADO M8 CABEZA REDUCIDA
BI6	BI000600	NR	INSERTO ESAGONALE M4	INSERT HEX M4	INSERT FILETE M4 TETE REDUITE	GEWINDEINSERT M4 REDUZIERTER KOPF	INSERTO ROSCADO M4 CABEZA REDUCIDA
BI7	BI000700	NR	INSERTO CILINDRICO M8	INSERT M8			
BR1	BR000100	NR	GROWER SEZ.RETT.SPIGOLI VIVI PESANTE UNI 9195 ACC.MOLLE D 6 Z.D.BIANCA	GROWER SEZ.RETT. SHARP HEAVY UNI 9195 ACC.MOLLE D 6 Z.D. WHITE	RONDELLE GROWER SECT.RECT. UNI 9195 ACC.MOLLE D 6 GALVANISÉE BLANCHE	GROWER UNTERLEGSCHIEBE UNI 9195 D 6 Z.D. WEIß	ARANDELA GROWER SEC. RECT. UNI 9195 D 6 GALVANIZADA BLANCA
BR2	BR000200	NR	RONDELLA PIANA DIN 125-A HV100 D 4 Z.BIANCA	PLAIN WASHER DIN 125-A HV100 D 4 Z. WHITE	RONDELLE PLATE DIN 125-A HV100 D 4 Z.BLANCHE	FLACHE UNTERLEGSCHIEBE DIN 125-A HV100 D 4 Z.WEIß	ARANDELA PLANA DIN 125-A HV100 D 4 GALVANIZADA BLANCA
BR3	BR000300	NR	RONDELLA PIANA DIN 125-A HV100 D 5 Z.BIANCA	PLAIN WASHER DIN 125-A HV100 D 5 Z. WHITE	RONDELLE PLATE DIN 125-A HV100 D 5 Z.BLANCHE	FLACHE UNTERLEGSCHIEBE DIN 125-A HV100 D 5 Z.WEIß	ARANDELA PLANA DIN 125-A HV100 D 5 GALVANIZADA BLANCA

POS	Codice	U.M.	 Descrizione	 Description	 Designation	 Benennung	 Descripción
BR4	BR000400	NR	RONDELLA PIANA DIN 125-A HV100 D 6 Z.BIANCA	PLAIN WASHER DIN 125-A HV100 D 6 Z. WHITE	RONDELLE PLATE DIN 125-A HV100 D 6 Z.BLANCHE	FLACHE UNTERLEGSCHLEIBE DIN 125-A HV100 D 6 Z. WEIß	ARANDELA PLANA DIN 125-A HV100 D 6 GALVANIZADA BLANCA
BR5	BR000500	NR	RONDELLA PIANA DIN 125-A HV100 D 8 Z.BIANCA	PLAIN WASHER DIN 125-A HV100 D 8 Z. WHITE	RONDELLE PLATE DIN 125-A HV100 D 8 Z.BLANCHE	FLACHE UNTERLEGSCHLEIBE DIN 125-A HV100 D 8 Z. WEIß	ARANDELA PLANA DIN 125-A HV100 D 8 GALVANIZADA BLANCA
BR6	BR000600	NR	RONDELLA PIANA DIN 125-A HV100 D 10 Z.BIANCA	PLAIN WASHER DIN 125-A HV100 D 10 Z. WHITE	RONDELLE PLATE DIN 125-A HV100 D 10 Z.BLANCHE	FLACHE UNTERLEGSCHLEIBE DIN 125-A HV100 D 10 Z. WEIß	ARANDELA PLANA DIN 125-A HV100 D 10 GALVANIZADA BLANCA
BR7	BR000700	NR	RONDELLA PIANA DIN 125-A HV100 D 12 Z.BIANCA	PLAIN WASHER DIN 125-A HV100 D 12 Z. WHITE	RONDELLE PLATE DIN 125-A HV100 D 12 Z.BLANCHE	FLACHE UNTERLEGSCHLEIBE DIN 125-A HV100 D 12 Z. WEIß	ARANDELA PLANA DIN 125-A HV100 D 12 GALVANIZADA BLANCA
BR8	BR000800	NR	ROSETTA PIANA FASCIA LARGA E=3D DIN 9021 HV100 D 10 X 30 X 2,5 Z.BIANCA	WIDE BAND AND FLAT WASHER DIN 9021 HV100 3D = D 10 X 30 X 2.5 Z WHITE	RONDELLE PLATE BANDE LARGE E=3D DIN 9021 HV100 D 10 X 30 X 2,5 Z.BLANCHE	FLACHE UNTERLEGSCHLEIBE DIN 9021 HV100 3D = D 10 X 30 X 2.5 Z WEIß	ARANDELA DE BANDA ANCHA DIN 9021 HV100 D 10 X 30 X 2,5 GALVANIZADA BLANCA
BR9	BR000900	NR	ROSETTA PIANA FASCIA LARGA E=3D DIN 9021 HV100 D 12 X 36 X 2,5 Z.BIANCA	WIDE BAND AND FLAT WASHER DIN 9021 HV100 3D = D 12 X 36 X 2.5 Z WHITE	RONDELLE PLATE LARGE BANDE =3D DIN 9021 HV100 D 12 X 36 X 2,5 GALVANISÉE BLANCHE	SCHEIBE	ARANDELA
BR10	BR001000	NR	RONDELLA X CARPENTERIA DIN 6916 HV 300 D 16 Z.BIANCA	CARPENTRY WASHER DIN 6916 HV 300 D 16 Z WHITE	RONDELLE POUR CHARPENTERIE DIN 6916 HV 300 D 16 Z.BLANCHE	ZIMMEREI UNTERLEGSCHLEIBE DIN 6916 HV 300 D 16 Z WEIß	ARANDELA DE CARPINTERÍA DIN 6916 HV 300 D 16 GALVANIZADA BLANCA
BR11	BR001100	NR	ROSETTE SPECIALI HV100 D 25 X 51 X 1 Z.BIANCA	SPECIAL WASHERS HV100 D 25 X 51 X 1 Z. WHITE	RONDELLES SPÉCIALES HV100 D 25 X 51 X 1 GALVANISATION BLANCHE	SCHEIBE	ARANDELA
BR13	BR001300	NR	RONDELLA DENTELLATURA ESTERNA DIN 6798-A ACC.MOLLE D 3 Z.D.BIANCA	WASHER EXTERNAL SERRATION DIN 6798-A ACC.MOLLE D 3 ZD WHITE	RONDELLE À DENTURE EXTÉRIEURE DIN 6798-A ACC.MOLLE D 3 Z.D GALVANISATION BLANCHE	SCHEIBE	ARANDELA
BR14	BR001400	NR	ROSETTA PIANA FASCIA LARGA E=3D DIN 9021 HV100 D 5 X 15 X 1,2 Z.BIANCA	WIDE BAND AND FLAT WASHER DIN 9021 HV100 3D = D 5 X 15 X 1.2 Z WHIT	RONDELLE PLATE BANDE LARGE E=3D DIN 9021 HV100 D 5 X 15 X 1,2 Z.BLANCHE	UNTERLEGSCHLEIBE DIN 9021 HV100 3D = D 5 X 15 X 1.2 Z WEIß	ARANDELA PLANA CINTA LUNGA DIN 9021 HV100 D 5 X 15 X 1,2 GALVANIZADA BLANCA

POS	Codice	U.M.	 Descrizione	 Description	 Designation	 Benennung	 Descripción
BR15	BR001500	NR	ROSETTA PIANA FASCIA LARGA E=3D DIN 9021 HV100 D 6 X 18 X 1,5 Z.BIANCA	WIDE BAND AND FLAT WASHER DIN 9021 HV100 3D = D 6 X 18 X 1.5 Z WHITE	RONDELLE PLATE BANDE LARGE E=3D DIN 9021 HV100 D 6 X 18 X 1,5 Z.BLANCHE	UNTERLEGSSCHEIBE DIN 9021 HV100 3D = D 6 X 18 X 1.5 Z WEIß	ARANDELA PLANA CINTA LUNGA E=3D DIN 9021 HV100 D 6 X 18 X 1,5 GALVANIZADA BLANCA
BR16	BR001600	NR	ROSETTA PIANA FASCIA LARGA E=3D DIN 9021 HV100 D 8 X 24 X 2 Z.BIANCA	WIDE BAND AND FLAT WASHER DIN 9021 HV100 3D = D 8 X 24 X 2 Z. WHITE	RONDELLE PLATE BANDE LARGE E=3D DIN 9021 HV100 D 8 X 24 X 2 Z.BLANCHE	UNTERLEGSSCHEIBE DIN 9021 HV100 3D = D 8 X 24 X 2 Z. WEIß	ARANDELA PLANA CINTA LUNGA E=3D DIN 9021 HV100 D 8 X 24 X 2 GALVANIZADA BLANCA
BR17	BR001700	NR	ROSETTA PIANA FASCIA LARGA E=3D DIN 9021 HV100 D 4 X 12 X 1 Z.BIANCA	WIDE BAND AND FLAT WASHER DIN 9021 HV100 D = 3D 4 X 12 X 1 Z. WHITE	RONDELLE PLASTE BANDE LARGEDIN 9021 HV100 D 4 X 12 X 1 GALVANISATION BLANCHE	SCHEIBE	ARANDELA
BR18	BR001800	NR	RONDELLA PIANA DIN 125-A NYLON D 4	PLAIN WASHER DIN 125-A NYLON D 4	RONDELLE PLATE DIN 125-A NYLON D 4	SCHEIBE	ARANDELA
BR19	BR001900	NR	RONDELLA PIANA DIN 125-A HV100 D 3 Z.BIANCA	PLAIN WASHER DIN 125-A HV100 D 3 Z. WHITE	RONDELLE PLATE DIN 125-A HV100 D 3 GALVANISATION BLANCHE	SCHEIBE	ARANDELA
BR20	BR002000	NR	RONDELLA PIANA DIN 125-A HV100 D 16 Z.BIANCA	PLAIN WASHER DIN 125-A HV100 D 16 Z. WHITE	RONDELLE PLATE DIN 125-A HV100 D 16 GALVANISATION BLANCHE	SCHEIBE	ARANDELA
BR21	BR002100	NR	ROSETTA PIANA FASCIA LARGA E=3D DIN 9021 HV100 D 16 X 48 X 4 Z.BIANCA	WIDE BAND AND FLAT WASHER DIN 9021 HV100 3D = D 16 X 48 X 4 Z. WHITE	RONDELLE PLATE BANDE LARGE E=3D DIN 9021 HV100 D 16 X 48 X 4 GALVANISÉE BLANCHE	FLACHE UNTERLEGSSCHEIBE DIN 9021 HV100 3D = D 16 X 48 X 4 Z. WEIß	ARANDELA PLANA BANDA ANCHA DIN 9021 HV100 D 16 X 48 X 4 GALVANIZADA BLANCA
BR22	BR002200	NR	GROWER SEZ.RETT.SPIGOLI VIVI PESANTE UNI 9195 ACC.MOLLE D 8 Z.D.BIANCA	GROWER SECTION. RECT. SHARP HEAVY UNI 9195 STAINLESS SPRINGS D 8 Z.D. WHITE	RONDELLE GROWER SECT. RECT. ARÊTES AIGUËS D 8 Z.D. BLANC	GROWER UNTERLEGSSCHEIBE - WEIß	ARANDELA GROWER SECT. RECT. ÁNGULOS VIVOS UNI 9195 GALVANIZADA BLANCA
BR23	BR002300	NR	ROSETTA PIANA FASCIA LARGA E=3D DIN 9021 HV100 D 3 X 12 X 1 Z.BIANCA	WIDE BAND AND FLAT WASHER DIN 9021 HV100 D = 3D 3 X 12 X 1 Z. WHITE	RONDELLE PLATE BANDE LARGE DIN 9021 HV100 D 3 X 12 X 1 GALVANISATION BLANCHE	SCHEIBE	ARANDELA
BR24	BR002400	NR	ROSETTA PIANA FASCIA LARGA E=3D DIN 9021 HV100 D 14 X 42 X 3 Z.BIANCA	WIDE BAND AND FLAT WASHER DIN 9021 HV100 D = 3D 14 X 42 X 3 Z. WHITE	RONDELLE PLATE BANDE LARGE DIN 9021 HV100 D 14 X 42 X 3 GALVANISATION BLANCHE	SCHEIBE	ARANDELA

POS	Codice	U.M.	 Descrizione	 Description	 Designation	 Benennung	 Descripción
BR25	BR002500	NR	GROWER SEZ.RETT.SPIGOLI VIVI PESANTE UNI 9195 ACC.MOLLE D 10 Z.D.BIANCA	GROWER SEZ.RETT. SHARP HEAVY UNI 9195 ACC.MOLLE D 10 Z.D. WHITE	RONDELLE GROWER SECT. RECT. ARÊTES AIGUËS UNI 9195 D 10 Z.D. BLANC	GROWER UNTERLEGSCHIEBE - WEIß	ARANDELA GROWER SECT. RECT. ÁNGULOS VIVOS UNI 9195 GALVANIZADA BLANCA
BR26	BR002600	NR	RONDELLA PIANA DIN 125-A D 30 Z.BIANCA	PLAIN WASHER DIN 125-A D 30 Z. WHITE	RONDELLE PLATE DIN 125-A D 30 GALVANISATION BLANCHE	SCHEIBE	ARANDELA
BR27	BR002700	NR	RONDELLA PIANA DIN 125-A HV100 D 14 Z.BIANCA	PLAIN WASHER DIN 125-A HV100 D 14 Z. WHITE	RONDELLE PLATE DIN 125-A HV100 D 14 Z.BLANCHE	FLACHE UNTERLEGSCHIEBE DIN 125-A HV100 D 14 Z. - WEIß	ARANDELA PLANA DIN 125-A HV100 D 14 GALVANIZADA BLANCA
BR28	BR002800	NR	ROSETTA PIANA FASCIA LARGA D 6 X 24 X 2 Z.BIANCA	WIDE BAND AND FLAT WASHER D 6 X 24 X 2 Z WHITE	RONDELLE PLATE BANDE LARGE D 6 X 24 X 2 Z BLANCHE	UNTERLEGSCHIEBE D 6 X 24 X 2 Z - WEIß	ARANDELA PLANA CINTA LUNGA D 6 X 24 X 2 GALVANIZADA BLANCA
BR29	BR002900	NR	RONDELLA PIANA DIN 125-A HV100 D 18 Z.BIANCA	PLAIN WASHER DIN 125-A HV100 D 18 Z. WHITE	RONDELLE PLATE DIN 125-A HV100 D 18 Z. BLANC	FLACHE UNTERLEGSCHIEBE DIN 125-A HV100 D 18 Z. WEIß	ARANDELA PLANA DIN 125-A HV100 D 18 GALVANIZADA BLANCA
BR30	BR003000	NR	RONDELLA PIANA DIN 125-A HV100 D 20 Z.BIANCA	PLAIN WASHER DIN 125-A HV100 D 20 Z. WHITE	RONDELLE PLATE DIN 125-A HV100 D 20 GALVANISÉE BLANCHE	FLACHE UNTERLEGSCHIEBE DIN 125-A HV100 D 20 Z. WEIß	ARANDELA PLANA DIN 125-A HV100 D 20 GALVANIZADA BLANCA
BR31	BR003100	NR	GROWER SEZ.RETT.SPIGOLI VIVI PESANTE UNI 9195 ACC.MOLLE D 12 Z.D.BIANCA	GROWER SEZ.RETT. SHARP HEAVY UNI 9195 ACC.MOLLE D 12 Z.D. WHITE	RONDELLE GROWER SECT. RECT. ARÊTE AIGUË UNI 9195 ACC.MOLLE D 12 Z.D.BLANC	GROWER UNTERLEGSCHIEBE UNI 9195 ACC.MOLLE D 12 Z.D. WEIß	ARANDELA GROWER SECT. RECT. ÁNGULOS VIVOS UNI 9195 D 12 GALVANIZADA BLANCA
BR32	BR003200	NR	ROSETTE SPECIALI HV100 D 30 X 42 X 0.5 Z.BIANCA	SPECIAL WASHERS HV100 D 30 X 42 X 0.5 Z. WHITE	RONDELLES SPÉCIALES HV100 D 30 X 42 X 0.5 GALVANISATION BLANCHE	SCHEIBE	ARANDELA
BR33	BR003300	NR	ROSETTE SPECIALI HV100 D 30 X 61 X 1 Z.BIANCA	SPECIAL WASHERS HV100 D 30 X 61 X 1 Z. WHITE	RONDELLES SPÉCIALES HV100 D 30 X 61 X 1 GALVANISATION BLANCHE	SCHEIBE	ARANDELA
BR34	BR003400	NR	ROSETTE SPECIALI HV100 D 42 X 52 X 0.2 Z.BIANCA	SPECIAL WASHERS HV100 D 42 X 52 X 0.2 Z. WHITE	RONDELLES SPÉCIALES HV100 D 42 X 52 X 0.2 GALVANISATION BLANCHE	SCHEIBE	ARANDELA
BR35	BR003500	NR	ROSETTE SPECIALI HV100 D 42 X 52 X 0.3 Z.BIANCA	SPECIAL WASHERS HV100 D 42 X 52 X 0.3 Z. WHITE	RONDELLES SPÉCIALES HV100 D 42 X 52 X 0.3 GALVANISATION BLANCHE	SCHEIBE	ARANDELA







Viteria







Fasteners





POS	Codice	U.M.	Descrizione	Description	Designation	Benennung	Descripción
BR36	BR003600	NR	ROSETTE SPECIALI HV100 D 42 X 52 X 1 Z.BIANCA	SPECIAL WASHERS HV100 D 42 X 52 X 1 Z. WHITE	RONDELLES SPÉCIALES HV100 D 42 X 52 X 1 GALVANISATION BLANCHE	SCHEIBE	ARANDELA
BR37	BR003700	NR	ROSETTE SPECIALI HV100 D 42 X 52 X 1.5 Z.BIANCA	SPECIAL WASHERS HV100 D 42 X 52 X 1.5 Z. WHITE	RONDELLES SPÉCIALES HV100 D 42 X 52 X 1.5 GALVANISATION BLANCHE	SCHEIBE	ARANDELA
BR38	BR003800	NR	ROSETTE SPECIALI HV100 D 42 X 52 X 2 Z.BIANCA	SPECIAL WASHERS HV100 D 42 X 52 X 2 Z. WHITE	RONDELLES SPÉCIALES HV100 D 42 X 52 X 2 GALVANISATION BLANCHE	SCHEIBE	ARANDELA
BR39	BR003900	NR	ROSETTA PIANA FASCIA LARGA E=3D DIN 9021 HV100 D 18 X 48 X 4 Z.BIANCA	WIDE BAND AND FLAT WASHER DIN 9021 HV100 3D = D 18 X 48 X 4 Z. WHITE	RONDELLE PLATE BANDE LARGE E=3D DIN 9021 HV100 D 18 X 48 X 4 GALVANISÉE BLANCHE	FLACHE UNTERLEGSCHIEBE DIN 9021 HV100 3D = D 18 X 48 X 4 Z. WEIß	ARANDELA PLANA BANDA ANCHA DIN 9021 HV100 D 18 X 48 X 4 GALVANIZADA BLANCA
BR40	BR004000	NR	ROSETTA SCHNORR ZINCATE D 6	WASHER	RONDELLE	SCHEIBE	ARANDELA
BR41	BR004100	NR	GROWER SEZ.RETT.SPIGOLI VIVI PESANTE UNI 9195 ACC.MOLLE D 14 Z.D.BIANCA	GROWER SEZ.RETT. SHARP HEAVY UNI 9195 ACC.MOLLE D 14 Z.D. WHITE	RONDELLE GROWER SECT. RECT. ARÊTE AIGUË UNI 9195 ACC.MOLLE D 14 Z.D.BLANC	GROWER UNTERLEGSCHIEBE UNI 9195 ACC.MOLLE D 14 Z.D. WEIß	ARANDELA GROWER SECT. RECT. ÁNGULOS VIVOS UNI 9195 D 14 GALVANIZADA BLANCA
BR42	BR004200	NR	RONDELLA X CARPENTERIA DIN 6916 HV 300 D 14 Z.BIANCA	CARPENTRY WASHER DIN 6916 HV 300 D 14 Z WHITE	RONDELLE POUR CHARPENTERIE DIN 6916 HV 300 D 14 Z.BLANCHE	ZIMMEREI UNTERLEGSCHIEBE DIN 6916 HV 300 D 14 Z WEIß	ARANDELA DE CARPINTERÍA DIN 6916 HV 300 D 14 GALVANIZADA BLANCA
BR43	BR004300	NR	RONDELLA X CARPENTERIA DIN 125-A HV 300 D 10 Z.BIANCA	CARPENTRY WASHER DIN 125-A HV 300 D 10 Z WHITE	RONDELLE POUR CHARPENTERIE DIN 125-A HV 300 D 10 Z.BLANCHE	ZIMMEREI UNTERLEGSCHIEBE DIN 125-A HV 300 D 10 Z WEIß	ARANDELA DE CARPINTERÍA DIN 125-A HV 300 D 10 GALVANIZADA BLANCA
BR44	BR004400	NR	RONDELLA X CARPENTERIA DIN 125-A HV 300 D 20 Z.BIANCA	CARPENTRY WASHER DIN 125-A HV 300 D 20 Z WHITE	RONDELLE POUR CHARPENTERIE DIN 125-A HV 300 D 20 Z.BLANCHE	ZIMMEREI UNTERLEGSCHIEBE DIN 125-A HV 300 D 20 Z WEIß	ARANDELA DE CARPINTERÍA DIN 125-A HV 300 D 20 GALVANIZADA BLANCA
BR45	BR004500	NR	RONDELLA PIANA DIN 125-A HV200 D 10 Z.BIANCA	PLAIN WASHER DIN 125-A HV200 D 10 Z. WHITE	RONDELLE POUR CHARPENTERIE	ZIMMEREI UNTERLEGSCHIEBE	ARANDELA DE CARPINTERÍA
BR48	BR004800	NR	RONDELLA PIANA DIN 125-A HV100 D 22 Z.BIANCA	PLAIN WASHER DIN 125-A HV100 D 22 Z. WHITE	RONDELLE POUR CHARPENTERIE	ZIMMEREI UNTERLEGSCHIEBE	ARANDELA DE CARPINTERÍA





POS	Codice	U.M.	 Descrizione	 Description	 Designation	 Benennung	 Descripción
BR49	BR004900	NR	ROSETTA PIANA FASCIA LARGA E=4D DIN 9021 HV100 D 12 X 48 X 2,5 Z.BIANCA	WASHER FLAT AND WIDE BAND E = 4D DIN 9021 HV100 D 12 X 48 X 2.5 Z. WHITE	RONDELLE POUR CHARPENTERIE	ZIMMEREI UNTERLEGSCHIEBE	ARANDELA DE CARPINTERÍA
BR50	BR005000	NR	ROSETTA PIANA FASCIA LARGA E=3D DIN 9021 HV100 D 20 X 60 X 4 Z.BIANCA	WASHER FLAT AND WIDE BAND E = 3D DIN 9021 HV100 D 20 X 60 X 4 Z. WHITE	RONDELLE POUR CHARPENTERIE	ZIMMEREI UNTERLEGSCHIEBE	ARANDELA DE CARPINTERÍA
BR53	BR005300	NR	RONDELLE ELASTICHE GROWER DIN 127-B ACC.MOLLE D 6 Z.D.BIANCA	ELASTIC WASHERS GROWER DIN 127-B ACC. SPRINGS D 6 Z.D. WHITE	RONDELLE POUR CHARPENTERIE	ZIMMEREI UNTERLEGSCHIEBE	ARANDELA DE CARPINTERÍA
BR54	BR005400	NR	ROSETTA DI SICUREZZA TIPO SCHNORR TIPO S INOX D 6	WASHER SCHNORR TYPE S INOX D 6 SECURITY	RONDELLE POUR CHARPENTERIE	ZIMMEREI UNTERLEGSCHIEBE	ARANDELA DE CARPINTERÍA
BR55	BR005500	NR	RONDELLA DENTELLATURA ESTERNA DIN 6798-A ACC.MOLLE D 5 Z.D.BIANCA	WASHER EXTERNAL SERRATION DIN 6798-A ACC. SPRINGS D 5 Z.D. WHITE	RONDELLE POUR CHARPENTERIE	ZIMMEREI UNTERLEGSCHIEBE	ARANDELA DE CARPINTERÍA
BR56	BR005600	NR	RONDELLA X CARPENTERIA DIN 6916 HV 300 D 12 Z.BIANCA	WASHER DIN 6916 HV 300 D 12 Z. WHITE	RONDELLE POUR CHARPENTERIE	ZIMMEREI UNTERLEGSCHIEBE	ARANDELA DE CARPINTERÍA
BR57	BR005700	NR	ROSETTE SPECIALI HV100 D 36 X 65 X 1 Z.BIANCA	SPECIAL WASHERS HV100 D 36 X 65 X 1 Z. WHITE	RONDELLES SPÉCIALES HV100 D 36 X 65 X 1 GALVANISATION BLANCHE	SCHEIBE	ARANDELA
BR58	BR005800	NR	ROSETTE SPECIALI HV100 D 50 X 60 X 1 Z.BIANCA	SPECIAL WASHERS HV100 D 50 X 60 X 1 Z. WHITE	RONDELLES SPÉCIALES HV100 D 50 X 60 X 1 GALVANISATION BLANCHE	SCHEIBE	ARANDELA
BR59	BR005900	NR	ROSETTE SPECIALI HV300 D 20 X 54 X 3 Z.BIANCA	SPECIAL WASHERS HV300 D 20 X 54 X 3 Z. WHITE	RONDELLES SPÉCIALES HV300 D 20 X 54 X 3 GALVANISATION BLANCHE	SCHEIBE HV300 D 20 X 54 X 3	ARANDELA HV300 D 20 X 54 X 3 Z.
BR60	BR006000	NR	RONDELLA PIANA DIN 125-A NYLON D 12	PLAIN WASHER DIN 125-A NYLON D 12	RONDELLE PLATE DIN 125-A NYLON D 12	SCHEIBE	ARANDELA
BR61	BR006100	NR	RONDELLA PIANA DIN 125-A INOX A2 D4	PLAIN WASHER DIN 125-A INOX A2 D4	RONDELLE POUR CHARPENTERIE	ZIMMEREI UNTERLEGSCHIEBE	ARANDELA DE CARPINTERÍA
BR62	BR006200	NR	RONDELLA PIANA DIN 125-A HV300 D 20 Z.BIANCA	PLAIN WASHER DIN 125-A HV300 D 20 Z. WHITE	RONDELLE POUR CHARPENTERIE	ZIMMEREI UNTERLEGSCHIEBE	ARANDELA DE CARPINTERÍA
BR63	BR006300	NR	RONDELLA ANTIROTAZIONE DIN463 HV100 D6.4 X M6	WASHER DIN463 HV100 D6.4 X M6	RONDELLE POUR CHARPENTERIE	ZIMMEREI UNTERLEGSCHIEBE	ARANDELA DE CARPINTERÍA







POS	Codice	U.M.	 Descrizione	 Description	 Designation	 Benennung	 Descripción
BS1	BS000100	NR	GRANO FILETTATO M6X12	SCREW	VIS	SCHRAUBE	TORNILLO
BS2	BS000200	NR	SPINA CIL. 8X16 UNI 6364-A H6 CMT + TMP	PIN CYLINDER 8 X 16 UNI 6364-A CMT H6 + TMP			
BS3	BS000300	NR	PRIGIONIERO M10X35	PIN	AXE	GEWINDESTIFT	CLAVIJA
BS4	BS000400	NR	SPINA ELASTICA 6X60 UNI 6873	PIN	AXE	STIFT	CLAVIJA
BS5	BS000500	NR	SPINA ELASTICA 6X14 UNI 6873	PIN	AXE	STIFT	CLAVIJA
BS6	BS000600	NR	SPINA SPIROL NORMALE DIN 7343 INOX A2 D 5X10	PIN	AXE	STIFT	CLAVIJA
BS7	BS000700	NR	RIVETTO ALLUMINIO Ø3X12	ALUMINUM RIVET Ø3X12			
BS8	BS000800	NR	MOLLA COMPRESSIONE INOX AISI 302 D10.668 S1.066 L31.75	SPRING COMPRESSION AISI 302 D10.668 S1.066 L31.75			
BS13	BS001300	NR	SPINA ELASTICA DIN 1481 ACC.MOLLE D 8 X 50	ELASTIC PIN DIN 1481 ACC SPRINGS D 8 X 50			
BS14	BS001400	NR	SPINA SPIROL NORMALE DIN 7343 ACC.MOLLE D 5 X 10	PIN SPIROL NORMAL DIN 7343 ACC. SPRINGS D 5 X 10			
BS15	BS001500	NR	RIVETTI A STRAPPO TB AL/AC DIN 7337 D 3,2 X 12	BLIND RIVETS TB AL / AC DIN 7337 D 3.2 X 12			
BS16	BS001600	NR	RIVETTI A STRAPPO TB AL/AC DIN 7337 D 4,8 X 12	BLIND RIVETS TB AL / AC DIN 7337 D 4.8 X 12			
BS17	BS001700	NR	RIVETTI A STRAPPO TB A2/A2 DIN 7337 D 4,8 X 12	BLIND RIVETS TB A2 / A2 DIN 7337 D 4.8 X 12			
BS21	BS002100	NR	RIVETTO ALLUMINIO Ø4X10	ALUMINUM RIVET Ø4X10			
BS22	BS002200	NR	PRIGIONIERO M10X80	PIN M10X80	AXE M10X80	GEWINDESTIFT M10X80	CLAVIJA M10X80
BV1	BV000100	NR	VITE TE PARZIALE FILETTO PG DIN 931 CL 8.8 M 8 X 80 Z.BIANCA	SCREW PARTIAL THREAD DIN 931 PG CL 8.8 M 8 X 80 Z. WHITE	VIS PARTIELLEMENT FILETÉE DIN 931 CL 8.8 M 8 X 80 GALVANISATION BLANCHE	SCHRAUBE	TORNILLO
BV2	BV000200	NR	VITE TE TUTTO FILETTO PG DIN 933 CL 8.8 M 8 X 60 Z.BIANCA	SCREW ALL THREAD DIN 933 PG CL 8.8 M 8 X 60 Z. WHITE	VIS ENTIÈREMENT FILETÉE DIN 933 CL 8.8 M 8 X 60 GALVANISATION BLANCHE	SCHRAUBE	TORNILLO

POS	Codice	U.M.	 Descrizione	 Description	 Designation	 Benennung	 Descripción
BV3	BV000300	NR	VITE TCEI PG DIN 912 CL 8.8 M 8 X 60 Z.BIANCA	SCREW DIN 912 PG CL 8.8 M8 X 60 Z. WHITE	VIS DIN 912 CL 8.8 M 8 X 60 GALVANISATION BLANCHE	SCHRAUBE	TORNILLO
BV4	BV000400	NR	VITE TE PARZIALE FILETTO PG DIN 931 CL 8.8 M 8 X 50 Z.BIANCA	SCREW PARTIAL THREAD DIN 931 PG CL 8.8 M 8 X 50 Z. WHITE	VIS PARTIELLEMENT FILETÉE BLANC	TEILGEWINDESCHRAUBE DIN 931 PG CL 8.8 M 8 X 50 Z. WEIß	TORNILLO PARCIALMENTE ROSCADO PG DIN 931 CL 8.8 M 8 X 50 GALVANIZADO BLANCO
BV5	BV000500	NR	VITE TCEI PG DIN 912 CL 8.8 M 8 X 45 Z.BIANCA	SCREW DIN 912 PG CL 8.8 M8 X 45 Z. WHITE	VIS DIN 912 CL 8.8 M 8 X 45 GALVANISATION BLANCHE	SCHRAUBE	TORNILLOL
BV6	BV000600	NR	VITE TCEI PG DIN 912 CL 8.8 M 8 X 40 Z.BIANCA	SCREW DIN 912 PG CL 8.8 M8 X 40 Z.BIANCA	VIS DIN 912 CL 8.8 M 8 X 40 GALVANISATION BLANCHE	SCHRAUBE	TORNILLO
BV7	BV000700	NR	VITE TE TUTTO FILETTO PG DIN 933 CL 8.8 M 8 X 35 Z.BIANCA	SCREW ALL THREAD DIN 933 PG CL 8.8 M 8 X 35 Z. WHITE	VIS TE ENTIÈREMENT FILETÉE DIN 933 PG CL 8.8 M 8 X 35 Z. BLANC	VOLLGEWINDESCHRAUBE DIN 933 PG CL 8.8 M 8 X 35 Z. WEIß	TORNILLO TOTALMENTE ROSCADO PG DIN 933 CL 8.8 M 8 X 35 GALVANIZADO BLANCO
BV8	BV000800	NR	VITE TE TUTTO FILETTO PG DIN 933 CL 8.8 M 8 X 30 Z.BIANCA	SCREW ALL THREAD DIN 933 PG CL 8.8 M 8 X 30 Z. WHITE	VIS TE ENTIÈREMENT FILETÉE DIN 933 PG CL 8.8 M 8 X 30 Z. BLANC	VOLLGEWINDESCHRAUBE DIN 933 PG CL 8.8 M 8 X 30 Z. WEIß	TORNILLO TOTALMENTE ROSCADO PG DIN 933 CL 8.8 M 8 X 30 GALVANIZADO BLANCO
BV9	BV000900	NR	VITE TE TUTTO FILETTO PG DIN 933 CL 8.8 M 8 X 25 Z.BIANCA	SCREW ALL THREAD DIN 933 PG CL 8.8 M 8 X 25 Z. WHITE	VIS TE ENTIÈREMENT FILETÉE PG DIN 933 CL 8.8 M 8 X 25 Z.BLANC	VOLLGEWINDESCHRAUBE DIN 933 PG CL 8.8 M 8 X 25 Z. WEIß	TORNILLO TOTALMENTE ROSCADO PG DIN 933 CL 8.8 M 8 X 25 GALVANIZADO BLANCO
BV10	BV001000	NR	VITE TCEI PG DIN 912 CL 8.8 M 8 X 25 Z.BIANCA	SCREW DIN 912 PG CL 8.8 M8 X 25 Z. WHITE	VIS TCEI PG DIN 912 CL 8.8 M 8 X 25 Z.BLANC	SCHRAUBE DIN 912 PG CL 8.8 M8 X 25 Z. WEIß	TORNILLO TCEI PG DIN 912 CL 8.8 M 8 X 25 GALVANIZADO BLANCO
BV11	BV001100	NR	VITE TE TUTTO FILETTO PG DIN 933 CL 8.8 M 8 X 20 Z.BIANCA	SCREW ALL THREAD DIN 933 PG CL 8.8 M 8 X 20 Z. WHITE	VIS TE ENTIÈREMENT FILETÉE PG DIN 933 CL 8.8 M 8 X 20 Z.BLANC	VOLLGEWINDESCHRAUBE DIN 933 PG CL 8.8 M 8 X 20 Z. WEIß	TORNILLO TOTALMENTE ROSCADO PG DIN 933 CL 8.8 M 8 X 20 GALVANIZADO BLANCO
BV12	BV001200	NR	VITE TE TUTTO FILETTO PG DIN 933 CL 8.8 M 8 X 16 Z.BIANCA	SCREW ALL THREAD DIN 933 PG CL 8.8 M 8 X 16 Z. WHITE	VIS TE ENTIÈREMENT FILETÉE PG DIN 933 CL 8.8 M 8 X 16 Z.BLANC	VOLLGEWINDESCHREUBE DIN 933 PG CL 8.8 M 8 X 16 Z. WEIß	TORNILLO TOTALMENTE ROSCADO PG DIN 933 CL 8.8 M 8 X 16 GALVANIZADO BLANCO
BV13	BV001300	NR	VITE TCEI PG DIN 912 CL 8.8 M 8 X 16 Z.BIANCA	SCREW DIN 912 PG CL 8.8 M8 X 16 Z. WHITE	VIS TCEI PG DIN 912 CL 8.8 M 8 X 16 GALVANISÉE BLANCHE	SCHRAUBE DIN 912 PG CL 8.8 M8 X 16 Z. WEIß	TORNILLO DIN 912 CL 8.8 M 8 X 16 GALVANIZADO BLANCO
BV14	BV001400	NR	VITE TE TUTTO FILETTO PG DIN 933 CL 8.8 M 8 X 14 Z.BIANCA	SCREW ALL THREAD DIN 933 PG CL 8.8 M 8 X 14 Z. WHITE	VIS ENTIÈREMENT FILETÉE DIN 933 CL 8.8 M 8 X 14 GALVANISATION BLANCHE	SCHRAUBE	TORNILLO

POS	Codice	U.M.	 Descrizione	 Description	 Designation	 Benennung	 Descripción
BV15	BV001500	NR	VITE TCEI PG DIN 912 CL 8.8 M 6 X 45 Z.BIANCA	SCREW DIN 912 M6 X 45 CL 8.8 Z. WHITE	VIS DIN 912 CL 8.8 M 6 X 45 GALVANISATION BLANCHE	SCHRAUBE	TORNILLO
BV16	BV001600	NR	VITE TCEI PG DIN 912 CL 8.8 M 6 X 30 Z.BIANCA	SCREW DIN 912 M6 X 30 CL 8.8 Z. WHITE	VIS TCEI PG DIN 912 CL 8.8 M 6 X 30 Z.BLANC	SCHRAUBE DIN 912 M6 X 30 CL 8.8 Z. WEIß	TORNILLO TCEI PG DIN 912 CL 8.8 M 6 X 30 GALVANIZADO BLANCO
BV17	BV001700	NR	VITE TSPEI PG DIN 7991 CL 10.9 M 6 X 30 Z.BIANCA	SCREW DIN 7991 CL 10.9 M 6 X 30 Z. WHITE	VIS DIN 7991 CL 10.9 M 6 X 30 GALVANISATION BLANCHE	SCHRAUBE	TORNILLO
BV18	BV001800	NR	VITE TE TUTTO FILETTO PG DIN 933 CL 8.8 M 6 X 30 Z.BIANCA	SCREW ALL THREAD DIN 933 PG CL 8.8 M 6 X 30 Z. WHITE	VIS ENTIÈREMENT FILETÉE DIN 933 CL 8.8 M 6 X 30 GALVANISÉE BLANCHE	VOLLGEWINDESCHRAUBE DIN 933 PG CL 8.8 M 6 X 30 Z. WEIß	TORNILLO TOTALMENTE ROSCADO DIN 933 CL 8.8 M 6 X 30 GALVANIZADO BLANCO
BV19	BV001900	NR	VITE TBEI PG ISO 7380 CL 10.9 M 6 X 30 Z.BIANCA	SCREW ISO 7380 CL 10.9 M 6 X 30 Z. WHITE	VIS ISO 7380 CL 10.9 M 6 X 30 GALVANISATION BLANCHE	SCHRAUBE	TORNILLO
BV20	BV002000	NR	VITE TE TUTTO FILETTO PG DIN 933 CL 8.8 M 6 X 12 Z.BIANCA	SCREW ALL THREAD DIN 933 PG CL 8.8 M 6 X 12 Z. WHITE	VIS TE ENTIÈREMENT FILETÉE PG DIN 933 CL 8.8 M 6 X 12 Z.BIANCA	VOLLGEWINDESCHRAUBE DIN 933 PG CL 8.8 M 6 X 12 Z. WEIß	TORNILLO TOTALMENTE ROSCADO PG DIN 933 CL 8.8 M 6 X 12 GALVANIZADO BLANCO
BV21	BV002100	NR	VITE TCEI PG DIN 912 CL 8.8 M 6 X 12 Z.BIANCA	SCREW DIN 912 PG CL 8.8 M 6 X 12 Z. WHITE	VIS DIN 912 CL 8.8 M 6 X 12 GALVANISATION BLANCHE	SCHRAUBE	TORNILLO
BV22	BV002200	NR	VITE TCEI PG DIN 912 CL 8.8 M 5 X 45 Z.BIANCA	SCREW DIN 912 PG CL 8.8 M 5 X 45 Z. WHITE	VIS DIN 912 CL 8.8 M 5 X 45 GALVANISATION BLANCHE	SCHRAUBE	TORNILLO
BV23	BV002300	NR	VITE TE UNF ANSI B18.2.1 GR.5 5/16 X 1" Z.BIANCA	SCREW UNF ANSI B18.2.1 GR.5 5/16 X 1" Z. WHITE	VIS UNF ANSI B18.2.1 GR.5 5/16 X 1" GALVANISATION BLANCHE	SCHRAUBE	TORNILLO
BV24	BV002400	NR	VITE TC CROCE PG DIN 7985 CL 4.8 M 4 X 8 Z.BIANCA	CROSS HEAD SCREW DIN 7985 PG CL 4.8 M 4 X 8 Z. WHITE	VIS TC EN CROIX PG DIN 7985 CL 4.8 M 4 X 8 Z.BLANC	KREUZSCHLITZCHRAUBE DIN 7985 PG CL 4.8 M 4 X 8 Z. WEIß	TORNILLO TC DE CRUZ PG DIN 7985 CL 4.8 M 4 X 8 GALVANIZADO BLANCO
BV25	BV002500	NR	VITE TCEI PG DIN 912 CL 8.8 M 4 X 16 Z.BIANCA	SCREW DIN 912 PG CL 8.8 M 4 X 16 Z. WHITE	VIS DIN 912 CL 8.8 M 4 X 16 GALVANISATION BLANCHE	SCHRAUBE	TORNILLO
BV26	BV002600	NR	VITE TCEI PG DIN 912 CL 8.8 M 6 X 50 Z.BIANCA	SCREW DIN 912 PG CL 8.8 M 6 X 50 Z. WHITE	VIS DIN 912 CL 8.8 M 6 X 50 GALVANISATION BLANCHE	SCHRAUBE	TORNILLO
BV27	BV002700	NR	VITE TSPEI PG DIN 7991 CL 10.9 M 6 X 40 Z.BIANCA	SCREW DIN 7991 CL 10.9 M 6 X 40 Z. WHITE	VIS DIN 7991 CL 10.9 M 6 X 40 GALVANISÉE BLANCHE	SCHRAUBE DIN 7991 CL 10.9 M 6 X 40 Z. WEIß	TORNILLO DIN 7991 CL 10.9 M 6 X 40 GALVANIZADO BLANCO

POS	Codice	U.M.	 Descrizione	 Description	 Designation	 Benennung	 Descripción
BV28	BV002800	NR	VITE TSPEI PG DIN 7991 CL 10.9 M 6 X 25 Z.BIANCA	SCREW DIN 7991 CL 10.9 M 6 X 25 Z. WHITE	VIS TSPEI PG DIN 7991 CL 10.9 M 6 X 25 Z.BLANC	SCHRAUBE DIN 7991 CL 10.9 M 6 X 25 Z. WEIß	TORNILLO TSPEI PG DIN 7991 CL 10.9 M 6 X 25 GALVANIZADO BLANCO
BV29	BV002900	NR	VITE TE TUTTO FILETTO PG DIN 933 CL 8.8 M 6 X 25 Z.BIANCA	SCREW ALL THREAD DIN 933 PG CL 8.8 M 6 X 25 Z. WHITE	VIS TE ENTIÈREMENT FILETÉE PG DIN 933 CL 8.8 M 6 X 25 Z.BLANC	VOLLGEWINDESCHRAUBE DIN 933 PG CL 8.8 M 6 X 25 Z. WEIß	TORNILLO TOTALMENTE ROSCADO PG DIN 933 CL 8.8 M 6 X 25 GALVANIZADO BLANCO
BV30	BV003000	NR	VITE TE TUTTO FILETTO PG DIN 933 CL 8.8 M 6 X 22 Z.BIANCA	SCREW ALL THREAD DIN 933 PG CL 8.8 M 6 X 22 Z. WHITE	VIS TE ENTIÈREMENT FILETÉE PG DIN 933 CL 8.8 M 6 X 22 Z.BLANC	VOLLGEWINDESCHRAUBE DIN 933 PG CL 8.8 M 6 X 22 Z. WEIß	TORNILLO TE TOTALMENTE ROSCADO PG DIN 933 CL 8.8 M 6 X 22 GALVANIZADO BLANCO
BV31	BV003100	NR	VITE TSPEI PG DIN 7991 CL 10.9 M 6 X 20 Z.BIANCA	SCREW DIN 7991 CL 10.9 M 6 X 20 Z. WHITE	VIS TSPEI PG DIN 7991 CL 10.9 M 6 X 20 Z.BLANC	SCHRAUBE DIN 7991 CL 10.9 M 6 X 20 Z. WEIß	TORNILLO TSPEI PG DIN 7991 CL 10.9 M 6 X 20 GALVANIZADO BLANCO
BV32	BV003200	NR	VITE TE TUTTO FILETTO PG DIN 933 CL 8.8 M 6 X 20 Z.BIANCA	SCREW ALL THREAD DIN 933 PG CL 8.8 M 6 X 20 Z. WHITE	VIS TE ENTIÈREMENT FILETÉE PG DIN 933 CL 8.8 M 6 X 20 Z.BLANC	VOLLGEWINDESCHRAUBE DIN 933 PG CL 8.8 M 6 X 20 Z. WEIß	TORNILLO TOTALMENTE ROSCADO PG DIN 933 CL 8.8 M 6 X 20 GALVANIZADO BLANCO
BV33	BV003300	NR	VITE TCEI PG DIN 912 CL 8.8 M 6 X 20 Z.BIANCA	SCREW DIN 912 PG CL 8.8 M 6 X 20 Z. WHITE	VIS TCEI PG DIN 912 CL 8.8 M 6 X 20 Z.BLANC	SCHRAUBE DIN 912 PG CL 8.8 M 6 X 20 Z. WEIß	TORNILLO TCEI PG DIN 912 CL 8.8 M 6 X 20 GALVANIZADO BLANCO
BV34	BV003400	NR	VITE TE TUTTO FILETTO PG DIN 933 CL 8.8 M 6 X 16 Z.BIANCA	SCREW ALL THREAD DIN 933 PG CL 8.8 M 6 X 16 Z. WHITE	VIS TE ENTIÈREMENT FILETÉE G DIN 933 CL 8.8 M 6 X 16 Z.BLANC	VOLLGEWINDESCHRAUBE DIN 933 PG CL 8.8 M 6 X 16 Z. WEIß	TORNILLO TOTALMENTE ROSCADO PG DIN 933 CL 8.8 M 6 X 16 GALVANIZADO BLANCO
BV35	BV003500	NR	VITE TBEI PG ISO 7380 CL 10.9 M 6 X 16 Z.BIANCA	SCREW ISO 7380 CL 10.9 M 6 X 16 Z. WHITE	VIS TBEI PG ISO 7380 CL 10.9 M 6 X 16 Z.BLANC	SCHRAUBE ISO 7380 CL 10.9 M 6 X 16 Z. WEIß	TORNILLO TBEI PG ISO 7380 CL 10.9 M 6 X 16 GALVANIZADO BLANCO
BV36	BV003600	NR	VITE TCEI PG DIN 912 CL 8.8 M 5 X 8 Z.BIANCA	SCREW DIN 912 PG CL 8.8 M 5 X 8 Z. WHITE	VIS DIN 912 CL 8.8 M 5 X 8 GALVANISATION BLANCHE	SCHRAUBE	TORNILLO
BV37	BV003700	NR	VITE TSPEI PG DIN 7991 CL 10.9 M 5 X 60 Z.BIANCA	SCREW DIN 7991 CL 10.9 M 5 X 60 Z. WHITE	VIS DIN 7991 CL 10.9 M 5 X 60 GALVANISATION BLANCHE	SCHRAUBE	TORNILLO
BV38	BV003800	NR	VITE TE PARZIALE FILETTO PG DIN 931 CL 8.8 M 5 X 60 Z.BIANCA	SCREW PARTIAL THREAD DIN 931 PG CL 8.8 M 5 X 60 Z. WHITE	VIS PARTILLEMENT FILETÉE DIN 931 CL 8.8 M 5 X 60 GALVANISATION BLANCHE	SCHRAUBE	TORNILLO
BV39	BV003900	NR	VITE TCEI PG DIN 912 CL 8.8 M 5 X 60 Z.BIANCA	SCREW DIN 912 PG CL 8.8 M 5 X 60 Z. WHITE	VIS DIN 912 CL 8.8 M 5 X 60 GALVANISATION BLANCHE	SCHRAUBE	TORNILLO





POS	Codice	U.M.	 Descrizione	 Description	 Designation	 Benennung	 Descripción
BV40	BV004000	NR	VITE TE PARZIALE FILETTO PG DIN 931 CL 8.8 M 5 X 55 Z.BIANCA	SCREW PARTIAL THREAD DIN 931 PG CL 8.8 M 5 X 55 Z. WHITE	VIS PARTIELLEMENT FILETÉE DIN 931 CL 8.8 M 5 X 55 GALVANISATION BLANCHE	SCHRAUBE	TORNILLO
BV41	BV004100	NR	VITE TE TUTTO FILETTO PG DIN 933 CL 8.8 M 5 X 16 Z.BIANCA	SCREW ALL THREAD DIN 933 PG CL 8.8 M 5 X 16 Z. WHITE	VIS TE ENTIÈREMENT FILETÉE PG DIN 933 CL 8.8 M 5 X 16 Z.BLANC	VOLLGEWINDESCHRAUBE DIN 933 PG CL 8.8 M 5 X 16 Z. WEIß	TORNILLO TOTALMENTE ROSCADO PG DIN 933 CL 8.8 M 5 X 16 GALVANIZADO BLANCO
BV42	BV004200	NR	VITE TC CROCE PG DIN 7985 CL 4.8 M 5 X 16 Z.BIANCA	CROSS HEAD SCREW DIN 7985 PG CL 4.8 M 5 X 16 Z. WHITE	VIS TC EN CROIX PG DIN 7985 CL 4.8 M 5 X 16 Z.BLANC	KREUZSCHLITZSCHRAUBE DIN 7985 PG CL 4.8 M 5 X 16 Z. WEIß	TORNILLO TC DE CRUZ PG DIN 7985 CL 4.8 M 5 X 16 GALVANIZADO BLANCO
BV43	BV004300	NR	VITE TE TUTTO FILETTO PG DIN 933 CL 8.8 M 5 X 12 Z.BIANCA	SCREW ALL THREAD DIN 933 PG CL 8.8 M 5 X 12 Z. WHITE	VIS ENTIÈREMENT FILETÉE DIN 933 CL 8.8 M 5 X 12 GALVANISATION BLANCHE	SCHRAUBE	TORNILLO
BV44	BV004400	NR	VITE TE UNF ANSI B18.2.1 GR.5 5/16 X 1"1/4 Z.BIANCA	SCREW UNF ANSI B18.2.1 GR.5 5/16 X 1 "1/4 Z. WHITE	VIS UNF ANSI B18.2.1 GR.5 5/16 X 1"1/4 GALVANISATION BLANCHE	SCHRAUBE	TORNILLO
BV45	BV004500	NR	VITE TE UNF ANSI B18.2.1 GR.5 5/16 X 1"1/4 Z.BIANCA	SCREW UNF ANSI B18.2.1 GR.5 5/16 X 1 "1/4 Z. WHITE	VIS UNF ANSI B18.2.1 GR.5 5/16 X 1"1/4 GALVANISATION BLANCHE	SCHRAUBE	TORNILLO
BV46	BV004600	NR	VITE TCEI PG DIN 912 CL 8.8 M 4 X 40 Z.BIANCA	SCREW DIN 912 PG CL 8.8 M 4 X 40 Z. WHITE	VIS DIN 912 CL 8.8 M 4 X 40 GALVANISATION BLANCHE	SCHRAUBE	TORNILLO
BV47	BV004700	NR	VITE TRILOB. AUTOFORM. TC CROCE PG DIN 7500-C C15 M 4 X 40 Z.BIANCA	TRILOB SCREW. AUTOFORM. TC CROSS PH DIN 7500-C C 15 M 4 X 40 Z. WHITE	VIS TRILOB. AUTOFORM. TC CROIX PG DIN 7500-C C15 M 4 X 40 GALVANISATION BLANCHE	SCHRAUBE	TORNILLO
BV48	BV004800	NR	VITE TRILOB. AUTOFORM. TC CROCE PG DIN 7500-C C15 M 4 X 20 Z.BIANCA	TRILOB SCREW. AUTOFORM. TC CROSS PG DIN 7500-C C15 M 4 X 20 Z. WHITE	VIS TRILOB. AUTOFORM. TC CROIX PG DIN 7500-C C15 M 4 X 20 GALVANISATION BLANCHE	SCHRAUBE	TORNILLO
BV49	BV004900	NR	VITE TC CROCE PG DIN 7985 CL 4.8 M 4 X 16 Z.BIANCA	CROSS HEAD SCREW DIN 7985 PG CL 4.8 M 4 X 16 Z. WHITE	VIS TC CROIX DIN 7985 CL 4.8 M 4 X 16 GALVANISATION BLANCHE	SCHRAUBE	TORNILLO
BV50	BV005000	NR	VITE AUTOFILETTANTE TE C/BORDINO DIN 6928 C15 4,8X50 Z.BIANCA	TAPPING SCREW TE C / BORDINO DIN 6928 C15 4.8 X50 Z. WHITE	VIS AUTOFILETÉE TE C/BORDINO DIN 6928 C15 4,8X50 GALVANISATION BLANCHE	SCHRAUBE	TORNILLO





POS	Codice	U.M.	 Descrizione	 Description	 Designation	 Benennung	 Descripción
BV51	BV005100	NR	VITE AUTOFILETTANTE TE C/BORDINO DIN 6928 C15 4,8X25 Z.BIANCA	TAPPING SCREW TE C / BORDINO DIN 6928 C15 4.8 X25 Z. WHITE	VIS AUTOFILETÉE TE C/BORDINO DIN 6928 C15 4,8X25 GALVANISATION BLANCHE	SCHRAUBE	TORNILLO
BV52	BV005200	NR	VITE TCEI PG DIN 912 CL 12.9 M 3 X 25 Z.D.BIANCA	SCREW DIN 912 M 3 CL 12.9 X 25 Z.D. WHITE	VIS TCEI PG DIN 912 CL 12.9 M 3 X 25 GALVANISATION BLANCHE	SCHRAUBE	TORNILLO
BV53	BV005300	NR	VITE TSPEI PG DIN 7991 CL 10.9 M 3 X 14 Z.BIANCA	SCREW DIN 7991 CL 10.9 M 3 X 14 Z. WHITE	VIS DIN 7991 CL 10.9 M 3 X 14 GALVANISATION BLANCHE	SCHRAUBLE	TORNILLO
BV54	BV005400	NR	VITE AUTOFIL.TC CROCE DIN 7981 C15 3,5 X 6,5 Z.BIANCA	AUTOFIL.TC CROSS SCREW DIN 7981 C15 3.5 X 6.5 Z. WHITE	VIS AUTOFILETÉE CROIX DIN 7981 C15 3,5 X 6,5 GALVANISATION BLANCHE	SCHRAUBE	TORNILLO
BV55	BV005500	NR	VITE TE PARZIALE FILETTO PG DIN 931 CL 10.9 M 16 X 55	SCREW PARTIAL THREAD DIN 931 PG CL 10.9 M 16 X 55	VIS TE PARTIELLEMENT FILETÉE PG DIN 931 CL 10.9 M 16 X 55	TEILGEWINDESCHRAUBE DIN 931 PG CL 10.9 M 16 X 55	TORNILLO PARCIALMENTE ROSCADO PG DIN 931 CL 10.9 M 16 X 55
BV56	BV005600	NR	VITE TE TUTTO FILETTO PG DIN 933 CL 8.8 M 16 X 40 Z.BIANCA	SCREW ALL THREAD DIN 933 PG CL 8.8 M 16 X 40 Z. WHITE	VIS ENTIÈREMENT FILETÉE DIN 933 CL 8.8 M 16 X 40 GALVANISATION BLANCHE	SCHRAUBE	TORNILLO
BV57	BV005700	NR	VITE TE PARZIALE FILETTO PG DIN 931 CL 10.9 M 16 X 220	SCREW PARTIAL THREAD DIN 931 PG CL 10.9 M 16 X 220	VIS PARTIELLEMENT FILETÉE DIN 931 CL 10.9 M 16 X 220	SCHRAUBE	TORNILLO
BV58	BV005800	NR	VITE TE 8.8 DIN933 M16X20 TESTA ALTA 8 ZN BIANCA	SCREW M16X20 DIN933 8.8 HEAD HIGH 8 ZN WHITE	VIS 8.8 DIN933 M16X20 TÊTE HAUTE 8 GALVANISATION BLANCHE	SCHRAUBE	TORNILLO
BV59	BV005900	NR	VITE TE TUTTO FILETTO PG DIN 933 CL 8.8 M 12 X 16 Z.BIANCA	SCREW ALL THREAD DIN 933 PG CL 8.8 M 12 X 16 Z. WHITE	VIS ENTIÈREMENT FILETÉE DIN 933 CL 8.8 M 12 X 16 GALVANISATION BLANCHE	SCHRAUBE	TORNILLO
BV60	BV006000	NR	VITE TE PARZIALE FILETTO PG DIN 931 CL 8.8 M 12 X 120 Z.BIANCA	SCREW PARTIAL THREAD DIN 931 PG CL 8.8 M 12 X 120 Z. WHITE	VIS PARTIELLEMENT FILETÉE DIN 931 CL 8.8 M 12 X 120 GALVANISATION BLANCHE	SCHRAUBE	TORNILLO
BV61	BV006100	NR	VITE TE PARZIALE FILETTO PG DIN 931 CL 8.8 M 10 X 50 Z.BIANCA	SCREW PARTIAL THREAD DIN 931 PG CL 8.8 M 10 X 50 Z. WHITE	VIS TE PARTIELLEMENT FILETÉE PG DIN 931 CL 8.8 M 10 X 50 Z.BLANC	TEILGEWINDESCHRAUBE DIN 931 PG CL 8.8 M 10 X 50 Z. WEIß	TORNILLO PARCIALMENTE ROSCADO PG DIN 931 CL 8.8 M 10 X 50 GALVANIZADO BLANCO

POS	Codice	U.M.	 Descrizione	 Description	 Designation	 Benennung	 Descripción
BV62	BV006200	NR	VITE TE TUTTO FILETTO PG DIN 933 CL 8.8 M 10 X 35 Z.BIANCA	SCREW ALL THREAD DIN 933 PG CL 8.8 M 10 X 35 Z. WHITE	VIS TE ENTIÈREMENT FILETÉE PG DIN 933 CL 8.8 M 10 X 35 Z.BLANC	VOLLGEWINDESCHRAUBE DIN 933 PG CL 8.8 M 10 X 35 Z. WEIß	TORNILLO TOTALMENTE ROSCADO PG DIN 933 CL 8.8 M 10 X 35 GALVANIZADO BLANCO
BV63	BV006300	NR	VITE TSPEI PG DIN 7991 CL 10.9 M 10 X 30 Z.BIANCA	SCREW DIN 7991 CL 10.9 M 10 X 30 Z. WHITE	VIS DIN 7991 CL 10.9 M 10 X 30 GALVANISATION BLANCHE	SCHRAUBE	TORNILLO
BV64	BV006400	NR	VITE TE TUTTO FILETTO PG DIN 933 CL 8.8 M 10 X 30 Z.BIANCA	SCREW ALL THREAD DIN 933 PG CL 8.8 M 10 X 30 Z. WHITE	VIS TE ENTIÈREMENT FILETÉE PG DIN 933 CL 8.8 M 10 X 30 Z.BLANC	VOLLGEWINDESCHRAUBE DIN 933 PG CL 8.8 M 10 X 30 Z. WEIß	TORNILLO PG DIN 933 CL 8.8 M 10 X 30 GALVANIZADO BLANCO
BV65	BV006500	NR	VITE TCEI PG DIN 912 CL 12.9 M 10 X 25 GEO 321 A	SCREW DIN 912 PG CL 12.9 M 10 X 25 GEO 321 A	VIS DIN 912 PG CL 12.9 M 10 X 25 GEO 321 A	SCHRAUBE DIN 912 PG CL 12.9 M 10 X 25 GEO 321 A	TORNILLO TCEI PG DIN 912 CL 12.9 M 10 X 25 GEO 321 A
BV66	BV006600	NR	VITE TCEI PG DIN 912 CL 8.8 M 10 X 25 Z.BIANCA	SCREW DIN 912 PG CL 8.8 M 10 X 25 Z. WHITE	VIS DIN 912 CL 8.8 M 10 X 25 GALVANISATION BLANCHE	SCHRAUBE	TORNILLO
BV67	BV006700	NR	VITE TE TUTTO FILETTO PG DIN 933 CL 8.8 M 10 X 20 Z.BIANCA	SCREW ALL THREAD DIN 933 PG CL 8.8 M 10 X 20 Z. WHITE	VIS ENTIÈREMENT FILETÉE PG DIN 933 CL 8.8 M 10 X 20 Z.BLANC	VOLLGEWINDESCHRAUBE DIN 933 PG CL 8.8 M 10 X 20 Z. WEIß	TORNILLO TOTALMENTE ROSCADO PG DIN 933 CL 8.8 M 10 X 20 GALVANIZADO BLANCO
BV68	BV006800	NR	VITE TE TUTTO FILETTO PG DIN 933 CL 8.8 M 10 X 18 Z.BIANCA	SCREW ALL THREAD DIN 933 PG CL 8.8 M 10 X 18 Z. WHITE	VIS ENTIÈREMENT FILETÉE DIN 933 PG CL 8.8 M 10 X 18 Z. BLANC	VOLLGEWINDESCHRAUBE DIN 933 PG CL 8.8 M 10 X 18 Z. WEIß	TORNILLO TOTALMENTE ROSCADO PG DIN 933 CL 8.8 M 10 X 18 GALVANIZADO BLANCO
BV69	BV006900	NR	VITE TRILOB. AUTOFORM. TSP CROCE PG DIN 7500-M C15 M 5 X 16 Z.BIANCA	TRILOB SCREW. AUTOFORM. TSP CROSS PG DIN 7500-M C15 M 5 X 16 Z. WHITE	VIS TRILOB. AUTOFORM. TSP CROIX PG DIN 7500-M C15 M 5 X 16 GALVANISATION BLANCHE	SCHRAUBE	TORNILLO
BV70	BV007000	NR	VITE TE PARZIALE FILETTO PG DIN 931 CL 8.8 M 8 X 70 Z.BIANCA	SCREW PARTIAL THREAD DIN 931 PG CL 8.8 M 8 X 70 Z. WHITE	VIS PARTIELLEMENT FILETÉE DIN 931 PG CL 8.8 M 8 X 70 Z. BLANC	TEILGEWINDESCHRAUBE DIN 931 PG CL 8.8 M 8 X 70 Z. WEIß	TORNILLO PARCIALMENTE ROSCADO PG DIN 931 CL 8.8 M 8 X 70 GALVANIZADO BLANCO
BV71	BV007100	NR	VITE TE PARZIALE FILETTO PG DIN 931 CL 8.8 M 8 X 65 Z.BIANCA	SCREW PARTIAL THREAD DIN 931 PG CL 8.8 M 8 X 65 Z. WHITE	VIS PARTIELLEMENT FILETÉE DIN 931 CL 8.8 M 8 X 65 GALVANISÉE BLANCHE	TEILGEWINDESCHRAUBE DIN 931 PG CL 8.8 M 8 X 65 Z. WEIß	TORNILLO PARCIALMENTE ROSCADO DIN 931 CL 8.8 M 8 X 65 GALVANIZADO BLANCO
BV72	BV007200	NR	VITE TE PARZIALE FILETTO PG DIN 931 CL 8.8 M 6 X 55 Z.BIANCA	SCREW PARTIAL THREAD DIN 931 PG CL 8.8 M 6 X 55 Z. WHITE	VIS PARTIELLEMENT FILETÉE DIN 931 CL 8.8 M 6 X 55 GALVANISÉE BLANCHE	TEILGEWINDESCHRAUBE DIN 931 PG CL 8.8 M 6 X 55 Z. WEIß	TORNILLO PARCIALMENTE ROSCADO DIN 931 CL 8.8 M 6 X 55 GALVANIZADO BLANCO





POS	Codice	U.M.	 Descrizione	 Description	 Designation	 Benennung	 Descripción
BV73	BV007300	NR	VITE TCEI PG DIN 912 CL 8.8 M 6 X 55 Z.BIANCA	SCREW DIN 912 PG CL 8.8 M 6 X 55 Z. WHITE	VIS TCEI PG DIN 912 CL 8.8 M 6 X 55 GALVANISATION BLANCHE	SCHRAUBE	TORNILLO
BV74	BV007400	NR	VITE TCEI PG DIN 912 CL 8.8 M 6 X 16 Z.BIANCA	SCREW DIN 912 PG CL 8.8 M 6 X 16 Z. WHITE	VIS DIN 912 CL 8.8 M 6 X 16 GALVANISATION BLANCHE	SCHRAUBE	TORNILLO
BV75	BV007500	NR	VITE TSPEI PG DIN 7991 CL 10.9 M 6 X 10 Z.BIANCA	SCREW DIN 7991 CL 10.9 M 6 X 10 Z. WHITE	VIS DIN 7991 CL 10.9 M 6 X 10 GALVANISATION BLANCHE	SCHRAUBE	TORNILLO
BV76	BV007600	NR	VITE TCEI PG DIN 912 CL 8.8 M 5 X 55 Z.BIANCA	SCREW DIN 912 PG CL 8.8 M 5 X 55 Z. WHITE	VIS DIN 912 CL 8.8 M 5 X 55 GALVANISATION BLANCHE	SCHRAUBE	TORNILLO
BV77	BV007700	NR	VITE TC CROCE PG DIN 7985 CL 4.8 M 6 X 16 Z.BIANCA	CROSS HEAD SCREW DIN 7985 PG CL 4.8 M 6 X 16 Z. WHITE	VIS DIN 7985 CL 4.8 M 6 X 16 GALVANISATION BLANCHE	SCHRAUBE	TORNILLO
BV78	BV007800	NR	VITE TRILOB. AUTOFORM. TC CROCE PG DIN 7500-C C15 M 5 X 12 Z.BIANCA	TRILOB SCREW. AUTOFORM. TC CROSS PG DIN 7500-C C15 M 5 X 12 Z. WHITE	VIS TRILOB. AUTOFORM. TC CROIX PG DIN 7500-C C15 M 5 X 12 GALVANISATION BLANCHE	SCHRAUBE	TORNILLO
BV79	BV007900	NR	VITE TE TUTTO FILETTO PG DIN 933 CL 8.8 M 4 X 35 Z.BIANCA	SCREW ALL THREAD DIN 933 PG CL 8.8 M 4 X 35 Z. WHITE	VIS ENTIÈREMENT FILETÉE DIN 933 CL 8.8 M 4 X 35 GALVANISATION BLANCHE	SCHRAUBE	TORNILLO
BV80	BV008000	NR	VITE AUTOFILETTANTE TE C/BORDINO DIN 6928 C15 4,8X35 Z.BIANCA	TAPPING SCREW TE C / BORDINO DIN 6928 C15 4.8 X35 Z. WHITE	VIS AUTOFILETÉE TE C/BORDINO DIN 6928 C15 4,8X35 GALVANISATION BLANCHE	SCHRAUBE	TORNILLO
BV81	BV008100	NR	VITE TCEI PG DIN 912 CL 12.9 M 3 X 14 Z.D.BIANCA	SCREW DIN 912 M 3 CL 12.9 X 14 Z.D. WHITE	VIS DIN 912 CL 12.9 M 3 X 14 GALVANISATION BLANCHE	SCHRAUBE	TORNILLO
BV82	BV008200	NR	VITE TE PARZIALE FILETTO PG DIN 931 CL 8.8 M 16 X 70 Z.BIANCA	SCREW PARTIAL THREAD DIN 931 PG CL 8.8 M 16 X 70 Z. WHITE	VIS PARTIELLEMENT FILETÉE PG DIN 931 CL 8.8 M 16 X 70 GALVANISATION BLANCHE	SCHRAUBE	TORNILLO
BV83	BV008300	NR	VITE TE PARZIALE FILETTO PG DIN 931 CL 8.8 M 16 X 260 Z.BIANCA	SCREW PARTIAL THREAD DIN 931 PG CL 8.8 M 16 X 260 Z. WHITE	VIS PARTIELLEMENT FILETÉE PG DIN 931 CL 8.8 M 16 X 260 GALVANISATION BLANCHE	SCHRAUBE	TORNILLO
BV84	BV008400	NR	VITE TE PARZIALE FILETTO PG DIN 931 CL 8.8 M 12 X 110 Z.BIANCA	SCREW PARTIAL THREAD DIN 931 PG CL 8.8 M 12 X 110 Z. WHITE	VIS PARTIELLEMENT FILETÉE DIN 931 CL 8.8 M 12 X 110 GALVANISATION BLANCHE	SCHRAUBE	TORNILLO













POS	Codice	U.M.	 Descrizione	 Description	 Designation	 Benennung	 Descripción
BV85	BV008500	NR	VITE TE TUTTO FILETTO PG DIN 933 CL 8.8 M 10 X 40 Z.BIANCA	SCREW THREAD DIN 933 PG CL 8.8 M 10 X 40 Z. WHITE	VIS FILETÉE DIN 933 PG CL 8.8 M 10 X 40 Z. BLANC	TEILGEWINDESCHRAUBE DIN 933 PG CL 8.8 M 10 X 40 Z. WEIß	TORNILLO ROSCADO PG DIN 933 CL 8.8 M 10 X 40 GALVANIZADO BLANCO
BV86	BV008600	NR	VITE TCEI PG DIN 912 CL 8.8 M 8 X 65 Z.BIANCA	SCREW DIN 912 PG CL 8.8 M 8 X 65 Z. WHITE	VIS DIN 912 CL 8.8 M 8 X 65 GALVANISATION BLANCHE	SCHRAUBE	TORNILLO
BV87	BV008700	NR	VITE TCEI PG DIN 912 CL 8.8 M 8 X 20 Z.BIANCA	SCREW DIN 931 PG CL 8.8 M 10 X 40 Z. WHITE	VIS DIN 931 PG CL 8.8 M 10 X 40 Z. BLANC	SCHRAUBE DIN 931 PG CL 8.8 M 10 X 40 Z. WEIß	TORNILLO TCEI PG DIN 912 CL 8.8 M 8 X 20 GALVANIZADO BLANCO
BV88	BV008800	NR	VITE TCEI PG DIN 912 CL 10.9 M 10 X 18 Z.BIANCA	SCREW DIN 912 PG CL 10.9 M 10 X 18 Z. WHITE	VIS DIN 912 CL 10.9 M 10 X 18 GALVANISATION BLANCHE	SCHRAUBE	TORNILLO
BV89	BV008900	NR	VITE TCEI PG DIN 912 CL 8.8 M 8 X 70 Z.BIANCA	SCREW DIN 912 PG CL 8.8 M 8 X 70 Z. WHITE	VIS DIN 912 CL 8.8 M 8 X 70 GALVANISATION BLANCHE	SCHRAUBE	TORNILLO
BV91	BV009100	NR	VITE TE PARZIALE FILETTO PG DIN 931 CL 8.8 M 6 X 40 Z.BIANCA	SCREW PARTIAL THREAD DIN 931 PG CL 8.8 M 6 X 40 Z. WHITE	VIS FILETÉE DIN 931 PG CL 8.8 M 6 X 40 Z. BLANC	VOLLGEWINDESCHRAUBE DIN 931 PG CL 8.8 M 6 X 40 Z. WEIß	TORNILLO PG DIN 931 CL 8.8 M 6 X 40 GALVANIZADO BLANCO
BV92	BV009200	NR	VITE TE TUTTO FILETTO PG DIN 933 CL 8.8 M 10 X 60 Z.BIANCA	SCREW ALL THREAD DIN 933 PG CL 8.8 M 10 X 60 Z. WHITE	VIS	SCHRAUBE	TORNILLO
BV93	BV009300	NR	VITE TSPEI PG DIN 7991 CL 10.9 M 5 X 20 Z.BIANCA	SCREW DIN 7991 CL 10.9 M 5 X 20 Z. WHITE	VIS DIN 7991 CL 10.9 M 5 X 20 GALVANISATION BLANCHE	SCHRAUBE	TORNILLO
BV94	BV009400	NR	VITE TC CROCE PG DIN 7985 CL 4.8 M 4 X 12 Z.BIANCA	CROSS HEAD SCREW DIN 7985 PG CL 4.8 M 4 X 12 Z. WHITE	VIS CROIX DIN 7985 CL 4.8 M 4 X 12 GALVANISATION BLANCHE	SCHRAUBE	TORNILLO
BV95	BV009500	NR	VITE TE TUTTO FILETTO PG DIN 933 CL 8.8 M 4 X 12 Z.BIANCA	SCREW ALL THREAD DIN 933 PG CL 8.8 M 4 X 12 Z. WHITE	VIS ENTIÈREMENT FILETÉE DIN 933 CL 8.8 M 4 X 12 GALVANISATION BLANCHE	SCHRAUBE	TORNILLO
BV96	BV009600	NR	VITE TCEI PG DIN 912 CL 12.9 M 12 X 30 DAC 320A	SCREW DIN 912 CL 12.9 M 12 X 30 DAC 320A	VIS DIN 912 CL 12.9 M 12 X 30 DAC 320A	SCHRAUBE DIN 912 CL 12.9 M 12 X 30 DAC 320A	TORNILLO TCEI PG DIN 912 CL 12.9 M 12 X 30 DAC 320A
BV97	BV009700	NR	VITE AUTOFIL.TESTA MEZZA TONDA C15 4,8 X 13 Z.BIANCA	HALF ROUND HEAD SELF TAPPING SCREW C15 4,8 X 13	VIS AUTOFILETÉE TÊTE DEMI-RONDE C15 4,8 X 13 GALVANISATION BLANCHE	SCHRAUBE	TORNILLO

POS	Codice	U.M.	 Descrizione	 Description	 Designation	 Benennung	 Descripción
BV98	BV009800	NR	VITE TC CROCE PG DIN 7985 CL 4.8 M 4 X 14 Z.BIANCA	SCREW DIN 7985 CL 4.8 M 4 X 14	VIS EN CROIX PG DIN 7985 CL 4.8 M 4 X 14 GALVANISÉE BLANCHE	KREUZSCHLITZSCHRAUBE DIN 7985 CL 4.8 M 4 X 14	TORNILLO CRUZ 7985 CL 4.8 M 4 X 14 GALVANIZADO BLANCO
BV99	BV009900	NR	VITE TE PARZIALE FILETTO PG DIN 931 CL 8.8 M 5 X 65 Z.BIANCA	SCREW PARTIAL THREAD DIN 931 PG CL 8.8 M 5 X 65 Z. WHITE	VIS PARTIELLEMENT FILETÉE DIN 931 CL 8.8 M 5 X 65 GALVANISATION BLANCHE	SCHRAUBE	TORNILLO
BV100	BV010000	NR	VITE AUTOFIL.TESTA MEZZA TONDA C15 4,8 X 16 Z.BIANCA	HALF ROUND HEAD SELF TAPPING SCREW C15 4,8 X 16	VIS AUTOFILETÉE TÊTE DEMI-RONDE C15 4,8 X 16 GALVANISATION BLANCHE	SCHRAUBE	TORNILLO
BV101	BV010100	NR	VITE TSPEI PG DIN 7991 CL 10.9 M 8 X 25 Z.BIANCA	SCREW DIN 7991 CL 10.9 M 8 X 25 Z. WHITE	VIS DIN 7991 CL 10.9 M 8 X 25 GALVANISATION BLANCHE		
BV102	BV010200	NR	VITE TCEI PG DIN 912 CL 8.8 M 4 X 30 Z.BIANCA	SCREW DIN 912 PG CL 8.8 M 4 X 30 WHITE Z	VIS DIN 912 CL 8.8 M 4 X 30 GALVANISATION BLANCHE	SCHRAUBE	TORNILLO
BV103	BV010300	NR	VITE TSPEI PG DIN 7991 CL 10.9 M 5 X 16 Z.BIANCA	SCREW DIN 7991 CL 10.9 M 5 X 16 Z. WHITE	VIS DIN 7991 CL 10.9 M 5 X 16 GALVANISATION BLANCHE	SCHRAUBE	TORNILLO
BV104	BV010400	NR	VITE TCEI BASSA PG DIN 7984 CL 10.9 M 12 X 18 Z.D.BIANCA	SCREW DIN 7984 LOW PG CL 10.9 M 12 X 18 Z. D. WHITE	VIS BASSE DIN 7984 CL 10.9 M 12 X 18 Z. BLANCHE	SCHRAUBE	TORNILLO
BV105	BV010500	NR	VITE TE PARZIALE FILETTO PG DIN 931 CL 8.8 M 12 X 75 Z.BIANCA	SCREW PARTIAL THREAD DIN 931 PG CL 8.8 M 12 X 75 Z. WHITE	VIS PARTIELLEMENT FILETÉE DIN 931 CL 8.8 M 12 X 75 GALVANISATION BLANCHE	SCHRAUBE	TORNILLO
BV106	BV010600	NR	VITE TE TUTTO FILETTO PG DIN 933 CL 8.8 M 8 X 22 Z.BIANCA	SCREW ALL THREAD DIN 933 PG CL 8.8 M 8 X 22 Z. WHITE	VIS ENTIÈREMENT FILETÉE DIN 933 PG CL 8.8 M 8 X 22 Z. BLANC	VOLLGEWINDESCHRAUBE DIN 933 PG CL 8.8 M 8 X 22 Z. WEIß	TORNILLO TOTALMENTE ROSCADO PG DIN 933 CL 8.8 M 8 X 22 GALVANIZADO BLANCO
BV107	BV010700	NR	VITE TE TUTTO FILETTO PG DIN 933 CL 8.8 M 6 X 35 Z.BIANCA	SCREW ALL THREAD DIN 933 PG CL 8.8 M 6 X 35 Z. WHITE	VIS ENTIÈREMENT FILETÉE DIN 933 CL 8.8 M 6 X 35 GALVANISATION BLANCHE	SCHRAUBE	TORNILLO
BV108	BV010800	NR	VITE TE PARZIALE FILETTO PG DIN 931 CL 8.8 M 4 X 45 Z.BIANCA	SCREW PARTIAL THREAD DIN 931 PG CL 8.8 M 4 X 45 Z. WHITE	VIS PARTIELLEMENT FILETÉE DIN 931 CL 8.8 M 4 X 45 GALVANISATION BLANCHE	SCHRAUBE	TORNILLO
BV109	BV010900	NR	VITE TE TUTTO FILETTO PG DIN 933 CL 10.9 M 16 X 45 Z.D.BIANCA	SCREW ALL THREAD DIN 933 PG CL 10.9 M 16 X 45 ZD WHITE	VIS ENTIÈREMENT FILETÉE DIN 933 CL 10.9 M 16 X 45 GALVANISATION BLANCHE	SCHRAUBE	TORNILLO





POS	Codice	U.M.	 Descrizione	 Description	 Designation	 Benennung	 Descripción
BV110	BV011000	NR	VITE TE PARZIALE FILETTO PG DIN 931 CL 10.9 M 16 X 100	SCREW PARTIAL THREAD DIN 931 PG CL 10.9 M 16 X 100	VIS PARTIELLEMENT FILETÉE DIN 931 CL 10.9 M 16 X 100	SCHRAUBE	TORNILLO
BV111	BV011100	NR	VITE TE PARZIALE FILETTO PG DIN 931 CL 10.9 M 16 X 105	SCREW PARTIAL THREAD DIN 931 PG CL 10.9 M 16 X 105	VIS PARTIELLEMENT FILETÉE DIN 931 CL 10.9 M 16 X 105	SCHRAUBE	TORNILLO
BV112	BV011200	NR	VITE TE TUTTO FILETTO PG DIN 933 CL 8.8 M 10 X 25 Z.BIANCA	SCREW ALL THREAD DIN 933 PG CL 8.8 M 10 X 25 Z. WHITE	VIS ENTIÈREMENT FILETÉE DIN 933 PG CL 8.8 M 10 X 25 Z. BLANC	VOLLGEWINDESCHRAUBE DIN 933 PG CL 8.8 M 10 X 25 Z. WEIß	TORNILLO TOTALMENTE ROSCADO PG DIN 933 CL 8.8 M 10 X 25 GALVANIZADO BLANCO
BV113	BV011300	NR	VITE TSPEI PG DIN 7991 CL 10.9 M 6 X 50 Z.BIANCA	TSPEI PG SCREW DIN 7991 CL 10.9 M 6 X 50 Z. WHITE	VIS DIN 7991 CL 10.9 M 6 X 50 Z. BLANC	TSPEI PG SCHRAUBE DIN 7991 CL 10.9 M 6 X 50 Z. WEIß	TORNILLO TSPEI PG DIN 7991 CL 10.9 M 6 X 50 GALVANIZADO BLANCO
BV114	BV011400	NR	VITE TSPEI PG DIN 7991 CL 10.9 M 8 X 25 Z.BIANCA	TSPEI PG SCREW DIN 7991 CL 10.9 M 8 X 25 Z. WHITE	VIS DIN 7991 CL 10.9 M 8 X 25 GALVANISATION BLANCHE	SCHRAUBE	TORNILLO
BV115	BV011500	NR	VITE TE TUTTO FILETTO PG DIN 933 CL 8.8 M 10 X 45 Z.BIANCA	SCREW ALL THREAD DIN 933 PG CL 8.8 M 10 X 45 Z. WHITE	VIS ENTIÈREMENT FILETÉE DIN 933 CL 8.8 M 10 X 45 GALVANISATION BLANCHE	SCHRAUBE	TORNILLO
BV116	BV011600	NR	VITE TE TUTTO FILETTO PG DIN 933 CL 8.8 M 5 X 8 Z.BIANCA	SCREW ALL THREAD DIN 933 PG CL 8.8 M 5 X 8 Z. WHITE	VIS ENTIÈREMENT FILETÉE DIN 933 CL 8.8 M 5 X 8 GALVANISATION BLANCHE	SCHRAUBE	TORNILLO
BV117	BV011700	NR	VITE TE TUTTO FILETTO PG DIN 933 CL 8.8 M 8 X 18 Z.BIANCA	SCREW ALL THREAD DIN 933 PG CL 8.8 M 8 X 18 Z. WHITE	VIS ENTIÈREMENT FILETÉE DIN 933 CL 8.8 M 8 X 18 GALVANISATION BLANCHE	SCHRAUBE	TORNILLO
BV118	BV011800	NR	VITE TE TUTTO FILETTO PG DIN 933 CL 8.8 M 8 X 40 Z.BIANCA	SCREW ALL THREAD DIN 933 PG CL 8.8 M 8 X 40 Z. WHITE	VIS ENTIÈREMENT FILETÉE DIN 933 PG CL 8.8 M 8 X 40 Z. BLANC	VOLLGEWINDESCHRAUBE DIN 933 PG CL 8.8 M 8 X 40 Z. WEIß	TORNILLO DIN 933 CL 8.8 M 8 X 40 GALVANIZADO BLANCO
BV119	BV011900	NR	VITE TCEI PG DIN 912 CL 8.8 M 8 X 100 Z.BIANCA	SCREW DIN 912 PG CL 8.8 M 8 X 100 Z. WHITE	VIS DIN 912 CL 8.8 M 8 X 100 GALVANISATION BLANCHE	SCHRAUBE	TORNILLO
BV120	BV012000	NR	VITE TCEI PG DIN 912 CL 8.8 M 8 X 110 Z.BIANCA	SCREW DIN 912 PG CL 8.8 M 8 X 110 Z. WHITE	VIS DIN 912 CL 8.8 M 8 X 110 GALVANISATION BLANCHE	SCHRAUBE	TORNILLO
BV121	BV012100	NR	VITE TE PARZIALE FILETTO PG DIN 931 CL 8.8 M 5 X 75 Z.BIANCA	SCREW PARTIAL THREAD DIN 931 PG CL 8.8 M 5 X 75 Z. WHITE	VIS PARTIELLEMENT FILETÉE DIN 931 CL 8.8 M 5 X 75 GALVANISATION BLANCHE	SCHRAUBE	TORNILLO

POS	Codice	U.M.	 Descrizione	 Description	 Designation	 Benennung	 Descripción
BV122	BV012200	NR	VITE TE PARZIALE FILETTO PG DIN 931 CL 8.8 M 12 X 130 Z.BIANCA	SCREW PARTIAL THREAD DIN 931 PG CL 8.8 M 12 X 130 Z. WHITE	VIS PARTIELLEMENT FILETÉE DIN 931 CL 8.8 M 12 X 130 GALVANISATION BLANCHE	SCHRAUBE	TORNILLO
BV123	BV012300	NR	VITE TC CROCE PG DIN 7985 CL 4.8 M 4 X 8 Z.BIANCA	CROSS HEAD SCREW DIN 7985 PG CL 4.8 M 4 X 8 Z. WHITE	VIS TC EN CROIX PG DIN 7985 CL 4.8 M 4 X 8 Z.BLANC	KREUZSCHLITZCHRAUBE DIN 7985 PG CL 4.8 M 4 X 8 Z. WEIß	TORNILLO TC DE CRUZ PG DIN 7985 CL 4.8 M 4 X 8 GALVANIZADO BLANCO
BV124	BV012400	NR	VITE TCEI PG DIN 912 CL 8.8 M 6 X 40 Z.BIANCA	SCREW DIN 912 PG CL 8.8 M 6 X 40 Z. WHITE	VIS DIN 912 CL 8.8 M 6 X 40 GALVANISATION BLANCHE	SCHRAUBE	TORNILLO
BV125	BV012500	NR	VITE TE TUTTO FILETTO PG DIN 933 CL 8.8 M 4 X 20 Z.BIANCA	SCREW ALL THREAD DIN 933 PG CL 8.8 M 4 X 20 Z. WHITE	VIS ENTIÈREMENT FILETÉE DIN 933 CL 8.8 M 4 X 20 GALVANISATION BLANCHE	SCHRAUBE	TORNILLO
BV126	BV012600	NR	VITE TE UNC ANSI B18.2.1 GR.5 3/8 X 1" Z.BIANCA	SCREW UNC ANSI B18.2.1 GR.5 3/8 X 1" Z. WHITE	VIS UNC ANSI B18.2.1 GR.5 3/8 X 1" GALVANISATION BLANCHE	SCHRAUBE	TORNILLO
BV127	BV012700	NR	VITE TE UNC ANSI B18.2.1 GR.5 3/8 X 1" 1/4Z.BIANCA	SCREW UNC ANSI B18.2.1 GR.5 3/8 X 1" 1/4 Z. WHITE	VIS UNC ANSI B18.2.1 GR.5 3/8 X 1" 1/4 GALVANISATION BLANCHE	SCHRAUBE	TORNILLO
BV128	BV012800	NR	VITE TE TUTTO FILETTO PG DIN 933 CL 8.8 M 4 X 16 Z.BIANCA	SCREW ALL THREAD DIN 933 PG CL 8.8 M 4 X 16 Z. WHITE	VIS ENTIÈREMENT FILETÉE DIN 933 CL 8.8 M 4 X 16 GALVANISATION BLANCHE	SCHRAUBE	TORNILLO
BV129	BV012900	NR	VITE TCEI PG DIN 912 CL 8.8 M 5 X 16 Z.BIANCA	SCREW DIN 912 PG CL 8.8 M 5 X 16 Z. WHITE	VIS DIN 912 CL 8.8 M 5 X 16 GALVANISATION BLANCHE	SCHRAUBE	TORNILLO
BV130	BV013000	NR	VITE TCEI PG DIN 912 CL 8.8 M 3 X 12 Z.BIANCA	SCREW DIN 912 PG CL 8.8 M 3 X 12 Z. WHITE	VIS DIN 912 CL 8.8 M 3 X 12 GALVANISATION BLANCHE	SCHRAUBE	TORNILLO
BV131	BV013100	NR	VITE TSPEI PG DIN 7991 CL 10.9 M 5 X 30 Z.BIANCA	TSPEI PG SCREW DIN 7991 CL 10.9 M 5 X 30 Z. WHITE	VIS DIN 7991 CL 10.9 M 5 X 30 GALVANISATION BLANCHE	SCHRAUBE	TORNILLO
BV132	BV013200	NR	VITE TSPEI PG DIN 7991 CL 10.9 M 5 X 55 Z.BIANCA	TSPEI PG SCREW DIN 7991 CL 10.9 M 5 X 55 Z. WHITE	VIS DIN 7991 CL 10.9 M 5 X 55 GALVANISATION BLANCHE	SCHRAUBE	TORNILLO
BV133	BV013300	NR	VITE TE TUTTO FILETTO PG DIN 933 CL 8.8 M 3 X 25 Z.BIANCA	SCREW ALL THREAD DIN 933 PG CL 8.8 M 3 X 25 Z. WHITE	VIS ENTIÈREMENT FILETÉE DIN 933 CL 8.8 M 3 X 25 GALVANISATION BLANCHE	SCHRAUBE	TORNILLO
BV134	BV013400	NR	VITE TE PARZIALE FILETTO PG DIN 931 CL 8.8 M 10 X 65 Z.BIANCA	SCREW PARTIAL THREAD DIN 931 PG CL 8.8 M 10 X 65 Z. WHITE	VIS PARTIELLEMENT FILETÉE DIN 931 CL 8.8 M 10 X 65 GALVANISATION BLANCHE	SCHRAUBE	TORNILLO





POS	Codice	U.M.	 Descrizione	 Description	 Designation	 Benennung	 Descripción
BV135	BV013500	NR	VITE TCEI PG DIN 912 CL 8.8 M 12 X 50	SCREW DIN 912 CL 9.8 M 12 X 50	VIS DIN 912 CL 8.8 M 12 X 50	SCHRAUBE DIN 912 CL 8.8 M 12 X 50	TORNILLO DIN 912 CL 8.8 M 12 X 50
BV136	BV013600	NR	VITE TSPEI PG DIN 7991 CL 10.9 M 5 X 25 Z.BIANCA	TSPEI PG SCREW DIN 7991 CL 10.9 M 5 X 25 Z. WHITE	VIS DIN 7991 CL 10.9 M 5 X 25 GALVANISATION BLANCHE	SCHRAUBE	TORNILLO
BV137	BV013700	NR	VITE TCEI PG DIN 912 CL 8.8 M 8 X 30	SCREW DIN 912 CL 8.8 M 8 X 30	VIS DIN 912 CL 8.8 M 8 X 30	SCHRAUBE DIN 912 CL 8.8 M 8 X 30	TORNILLO DIN 912 CL 8.8 M 8 X 30
BV138	BV013800	NR	VITE TC CROCE PG DIN 7985 CL 4.8 M 5 X 10 Z.BIANCA	SCREW DIN 7985 CL 4.8 M 5 X 10	VIS CROIX DIN 7985 CL 4.8 M 5 X 10 GALVANISATION BLANCHE	SCHRAUBE	TORNILLO
BV139	BV013900	NR	VITE TCEI PG DIN 912 CL 8.8 M 4 X 25 Z. BIANCA	SCREW DIN 912 CL 8.8 M 4 X 25 Z.WITHE	VIS DIN 912 CL 8.8 M 4 X 25 GALVANISATION BLANCHE	SCHRAUBE	TONILLO
BV140	BV014000	NR	VITE TE PARZIALE FILETTO PG DIN 931 CL 8.8 M 5 X 70 Z.BIANCA	SCREW PARTIAL THREAD DIN 931 PG CL 8.8 M 5 X 70 Z. WHITE	VIS PARTIELLEMENT FILETÉE DIN 931 CL 8.8 M 5 X 70 GALVANISATION BLANCHE	SCHRAUBE	TORNILLO
BV141	BV014100	NR	VITE TE PARZIALE FILETTO PG DIN 931 CL 8.8 M 12 X 90 Z.BIANCA	SCREW PARTIAL THREAD DIN 931 PG CL 8.8 M 12 X 90 Z. WHITE	VIS PARTIELLEMENT FILETÉE DIN 931 CL 8.8 M 12 X 90 GALVANISATION BLANCHE	SCHRAUBE	TORNILLO
BV142	BV014200	NR	VITE TE PARZIALE FILETTO PG DIN 931 CL 8.8 M 8 X 55 Z.BIANCA	SCREW PARTIAL THREAD DIN 931 PG CL 8.8 M 8 X 55 Z. WHITE	VIS PARTIELLEMENT FILETÉE DIN 931 CL 8.8 M 8 X 55 GALVANISATION BLANCHE	SCHRAUBE	TORNILLO
BV143	BV014300	NR	VITE TSPEI PG DIN 7991 CL 10.9 M 10 X 20 Z.BIANCA	TSPEI PG SCREW DIN 7991 CL 10.9 M 10 X 20 Z. WHITE	VIS DIN 7991 CL 10.9 M 10 X 20 GALVANISATION BLANCHE	SCHRAUBE	TORNILLO
BV144	BV014400	NR	VITE TE TUTTO FILETTO PG DIN 933 CL 8.8 M 12 X 20 Z.BIANCA	SCREW ALL THREAD DIN 933 PG CL 8.8 M 12 X 20 Z. WHITE	VIS ENTIÈREMENT FILETÉE DIN 933 CL 8.8 M 12 X 20 GALVANISATION BLANCHE	SCHRAUBE	TORNILLO
BV145	BV014500	NR	VITE TE TUTTO FILETTO PG DIN 933 CL 8.8 M 12 X 35 Z.BIANCA	SCREW ALL THREAD DIN 933 PG CL 8.8 M 12 X 35 Z. WHITE	VIS ENTIÈREMENT FILETÉE DIN 933 PG CL 8.8 M 12 X 35 Z. BLANC	VOLLGEWINDESCHRAUBE DIN 933 PG CL 8.8 M 12 X 35 Z. WEIß	TORNILLO TOTALMENTE ROSCADO DIN 933 CL 8.8 M 12 X 35 GALVANIZADO BLANCO
BV146	BV014600	NR	VITE TE TUTTO FILETTO PF DIN 961 CL 10.9 M 10 X 1,25 X 25 Z.D.BIANCO	ALL PF THREAD HEX HEAD SCREW DIN 961 CL 10.9 M 10 X 1,25 X 25 Z.BIANCA	VIS ENTIÈREMENT FILETÉE DIN 961 CL 10.9 M 10 X 1,25 X 25 GALVANISÉE BLANCHE	VOLLGEWINDESCHRAUBE DIN 961 CL 10.9 M 10 X 1,25 X 25 Z. WEIß	TORNILLO TOTALMENTE ROSCADO DIN 961 CL 10.9 M 10 X 1,25 X 25 GALVANIZADO BLANCO





POS	Codice	U.M.	 Descrizione	 Description	 Designation	 Benennung	 Descripción
BV147	BV014700	NR	VITE TSPEI PARZIALE FILETTO PG DIN 7991 CL 10.9 M 12 X 90 Z.BIANCA	TSPEI PARTIAL THREAD PG SCREW DIN 7991 CL 10.9 M12 X 90 Z. WHITE	VIS TSPEI PG DIN 7991 CL 10.9 M 12 X 90 GALVANISATION BLANCHE	SCHRAUBE	TORNILLO
BV148	BV014800	NR	VITE TSPEI PG DIN 7991 CL 10.9 M 6 X 16 Z.BIANCA	TSPEI PG SCREW DIN 7991 CL 10.9 M6 X 16 Z. WHITE	VIS TSPEI PG DIN 7991 CL 10.9 M 6 X 16 GALVANISATION BLANCHE	SCHRAUBE	TORNILLO
BV149	BV014900	NR	VITE TBEI PG ISO 7380 CL 10.9 M 6 X 20 Z.BIANCA	HEX SOCKET SCREW ISO 7380 PG CL 10.9 M 6 X 20 Z. WHITE	VIS ISO 7380 CL 10.9 M 6 X 20 GALVANISATION BLANCHE	SCHRAUBE	TORNILLO
BV150	BV015000	NR	VITE TE TUTTO FILETTO PG DIN 933 CL 10.9 M 14 X 40 Z.BIANCA	SCREW ALL THREAD DIN 933 PG CL 10.9 M 14 X 40 Z. WHITE	VIS ENTIÈREMENT FILETÉE DIN 933 CL 10.9 M 14 X 40 GALVANISATION BLANCHE	SCHRAUBE	TORNILLO
BV151	BV015100	NR	VITE TE PARZIALE FILETTO PG DIN 931 CL 8.8 M 10 X 85 Z.BIANCA	SCREW PARTIAL THREAD DIN 931 PG CL 8.8 M 10 X 85 Z. WHITE	VIS PARTIELLEMENT FILETÉE DIN 931 PG CL 8.8 M 10 X 85 Z. BLANC	TEILGEWINDESCHRAUBE DIN 931 PG CL 8.8 M 10 X 85 Z. WEIß	TORNILLO PARCIALMENTE ROSCADO PG DIN 931 CL 8.8 M 10 X 85 GALVANIZADO BLANCO
BV152	BV015200	NR	VITE TE PARZIALE FILETTO PG DIN 931 CL 8.8 M 10 X 75 Z.BIANCA	SCREW PARTIAL THREAD DIN 931 PG CL 8.8 M 10 X 75 Z. WHITE	VIS PARTIELLEMENT FILETÉE DIN 931 PG CL 8.8 M 10 X 75 Z. BLANC	TEILGEWINDESCHRAUBE DIN 931 PG CL 8.8 M 10 X 75 Z. WEIß	TORNILLO PARCIALMENTE ROSCADO PG DIN 931 CL 8.8 M 10 X 75 GALVANIZADO BLANCO
BV154	BV015400	NR	VITE TCEI PG DIN 912 CL 8.8 M 8 X 35	SCREW DIN 912 CL 8.8 M 8 X 35	VIS DIN 912 CL 8.8 M 8 X 35	SCHRAUBE DIN 912 CL 8.8 M 8 X 35	TORNILLO TCEI PG DIN 912 CL 8.8 M 8 X 35
BV155	BV015500	NR	VITE TCEI PG DIN 912 CL 8.8 M 5 X 20 GEOMET 321A	SCREW DIN 912 CL 8.8 M 5 X 20 GEOMET 321A	VIS DIN 912 CL 8.8 M 5 X 20 GEOMET 321A	SCHRAUBE DIN 912 CL 8.8 M 5 X 20 GEOMET 321A	TORNILLO TCEI PG DIN 912 CL 8.8 M 5 X 20 GEOMET 321A
BV156	BV015600	NR	VITE TBEI PG ISO 7380 CL 10.9 M 6 X 25 Z.BIANCA	HEX SOCKET SCREW ISO 7380 PG CL 10.9 M 6 X 25 Z. WHITE	VIS ISO 7380 PG CL 10.9 M 6 X 25 Z. BLANC	SCHRAUBE ISO 7380 PG CL 10.9 M 6 X 25 Z. WEIß	TORNILLO TBEI PG ISO 7380 CL 10.9 M 6 X 25 GALVANIZADO BLANCO
BV157	BV015700	NR	VITE TBEI PG ISO 7380 CL 10.9 M 8 X 20 Z.BIANCA	HEX SOCKET SCREW ISO 7380 PG CL 10.9 M 8 X 20 Z. WHITE	VIS ISO 7380 PG CL 10.9 M 8 X 20 Z. BLANC	TBEI PG SCHRAUBE ISO 7380 CL 10.9 M 8 X 20 Z. WEIß	TORNILLO TBEI PG ISO 7380 CL 10.9 M 8 X 20 GALVANIZADO BLANCO
BV158	BV015800	NR	VITE TBEI PG ISO 7380 CL 10.9 M 6 X 70 Z.BIANCA	HEX SOCKET SCREW ISO 7380 PG CL 10.9 M 6 X 70 Z. WHITE	VIS ISO 7380 PG CL 10.9 M 6 X 70 Z. BLANC	TBEI PG SCHRAUBE ISO 7380 PG CL 10.9 M 6 X 70 Z. WEIß	TORNILLO TBEI PG ISO 7380 CL 10.9 M 6 X 70 GALVANIZADO BLANCO

POS	Codice	U.M.	 Descrizione	 Description	 Designation	 Benennung	 Descripción
BV159	BV015900	NR	VITE TBEI PG ISO 7380 CL 10.9 M 10 X 20 Z.BIANCA	HEX SOCKET SCREW ISO 7380 PG CL 10.9 M 10 X 20 Z. WHITE	VIS SO 7380 PG CL 10.9 M 10 X 20 Z. BLANC	TBEI PG SCHRAUBE ISO 7380 PG CL 10.9 M 10 X 20 Z. WEIß	TORNILLO TBEI PG ISO 7380 CL 10.9 M 10 X 20 GALVANIZADO BLANCO
BV160	BV016000	NR	VITE TSPEI PG DIN 7991 CL 10.9 M 4 X 16 Z.BIANCA	TSPEI PG SCREW DIN 7991 CL 10.9 M4 X 16 Z. WHITE	VIS DIN 7991 CL 10.9 M4 X 16 Z. WHITE	TSPEI PG SCHRAUBE DIN 7991 CL 10.9 M4 X 16 Z. WEIß	TORNILLO TSPEI PG DIN 7991 CL 10.9 M 4 X 16 GALVANIZADO BLANCO
BV162	BV016200	NR	VITE TCEI PG DIN 912 CL 12.9 M14 X 45 GEOMET 321A	SCREW DIN 912 CL 12.9 M14 X 45 GEOMET 321A	VIS TCEI PG DIN 912 CL 12.9 M14 X 45 GEOMET 321A	SCHRAUBE TCEI PG DIN 912 CL 12.9 M14 X 45 GEOMET 321A	TORNILLO TCEI PG DIN 912 CL 12.9 M14 X 45 GEOMET 321A
BV163	BV016300	NR	VITE TCEI PG DIN 912 CL 8.8 M6 X 35	SCREW DIN 912 CL 8.8 M6 X 35	VIS DIN 912 CL 8.8 M6 X 35	SCHRAUBE DIN 912 CL 8.8 M6 X 35	TORNILLO DIN 912 CL 8.8 M6 X 35
BV164	BV016400	NR	VITE TCEI PG DIN 912 CL 8.8 M10 X 35	SCREW DIN 912 CL 8.8 M10 X 35	VIS DIN 912 CL 8.8 M10 X 35	SCHRAUBE DIN 912 CL 8.8 M10 X 35	TORNILLO DIN 912 CL 8.8 M10 X 35
BV165	BV016500	NR	VITE TE TUTTO FILETTO PG DIN 933 CL 8.8 M8 X 12 Z.BIANCA	SCREW ALL THREAD DIN 933 PG CL 8.8 M8 X 12 Z. WHITE	VIS ENTIÈREMENT FILETÉE DIN 933 PG CL 8.8 M8 X 12 Z. BLANC	VOLLGEWINDESCHRAUBE DIN 933 PG CL 8.8 M8 X 12 Z. WEIß	TORNILLO TOTALMENTE ROSCADO PG DIN 933 CL 8.8 M8 X 12 GALVANIZADO BLANCO
BV166	BV016600	NR	VITE TCEI PG DIN 912 CL 8.8 M4 X 20 Z. BIANCA	SCREW DIN 912 CL 8.8 M4 X 20 Z. WITHE	VIS DIN 912 CL 8.8 M4 X 20	SCHRAUBE DIN 912 CL 8.8 M4 X 20	TORNILLO TCEI PG DIN 912 CL 8.8 M4 X 20
BV167	BV016700	NR	VITE TCEI PG DIN 912 CL 8.8 M4 X 20 GEOMET 321A	ALL PF THREAD HEX HEAD SCREW DIN 961 CL 8.8 M 12 X 1,25 X 30 Z.BIANCA	VIS ENTIÈREMENT FILETÉE DIN 961 CL 8.8 M 12 X 1,25 X 30 Z.BLANC	VOLLGEWINDESCHRAUBE DIN 961 CL 8.8 M 12 X 1,25 X 30 Z. WEIß	TORNILLO TOTALMENTE ROSCADO TCEI PG DIN 912 CL 8.8 M4 X 20 GEOMET 321A
BV168	BV016800	NR	VITE TE TUTTO FILETTO PF DIN 961 CL 8.8 M 10 X 1,25 X 30 Z.BIANCA	ALL PF THREAD HEX HEAD SCREW DIN 961 CL 8.8 M 10 X 1,25 X 30 Z.BIANCA	VIS ENTIÈREMENT FILETÉE DIN 961 CL 8.8 M 10 X 1,25 X 30 Z.BLANC	VOLLGEWINDESCHRAUBE DIN 961 CL 8.8 M 10 X 1,25 X 30 Z. WEIß	TORNILLO TOTALMENTE ROSCADO PF DIN 961 CL 8.8 M 10 X 1,25 X 30 GALVANIZADO BLANCO
BV169	BV016900	NR	VITE TCEI PG DIN 912 CL 8.8 M 10 X 1,25 X 30 ZINCATA BIANCA	SCREW DIN 912 CL 8.8 M10 X 1,25 X 30	VIS DIN 912 CL 8.8 M10 X 1,25 X 30	SCHRAUBE DIN 912 CL 8.8 M10 X 1,25 X 30	TORNILLO TCEI PG DIN 912 CL 8.8 M 10 X 1,25 X 30
BV170	BV017000	NR	VITE TE PARZIALE FILETTO PF DIN 960 CL 8.8 M 10 X 1,25 X 60 Z.BIANCA	PARTIAL PF THREAD HEX HEAD SCREW DIN 960 CL 8.8 M 10 X 1,25 X 60 Z.BIANCA	VIS FILETÉE DIN 960 CL 8.8 M 10 X 1,25 X 60 Z.BLANC	VOLLGEWINDESCHRAUBE DIN 960 CL 8.8 M 10 X 1,25 X 60 Z. WEIß	TORNILLO ROSCADO DIN 960 CL 8.8 M 10 X 1,25 X 30 GALVANIZADO BLANCO
BV171	BV017100	NR	VITE TE TUTTO FILETTO PF DIN 961 CL 10.9 M 12 X 1,25 X 25 Z.BIANCA	ALL PF THREAD HEX HEAD SCREW DIN 961 CL 10.9 M 12 X 1,25 X 25 Z.BIANCA	VIS ENTIÈREMENT FILETÉE DIN 961 CL 10.9 M 12 X 1,25 X 25 Z.BLANC	VOLLGEWINDESCHRAUBE DIN 961 CL 10.9 M 12 X 1,25 X 25 Z. WEIß	TORNILLO TOTALMENTE ROSCADO DIN 961 CL 10.9 M 12 X 1,25 X 25 GALVANIZADO BLANCO





POS	Codice	U.M.	 Descrizione	 Description	 Designation	 Benennung	 Descripción
BV172	BV017200	NR	VITE TCEI UNC ASME/ANSI B18.3 ASTM A 574 5/8 X 11/2 GEO 321A	VITE TCEI UNC ASME/ANSI B18.3 ASTM A 574 5/8 X 11/2 GEO 321A	VIS TCEI UNC ASME/ANSI B18.3 ASTM A 574 5/8 X 11/2 GEO 321A	SCHRAUBE TCEI UNC ASME/ANSI B18.3 ASTM A 574 5/8 X 11/2 GEO 321A	TORNILLO TCEI UNC ASME/ANSI B18.3 ASTM A 574 5/8 X 11/2 GEO 321A
BV173	BV017300	NR	VITE TE TUTTO FILETTO PG DIN 933 CL 8.8 M12 X 30 Z.BIANCA	SCREW ALL THREAD DIN 933 PG CL 8.8 M12 X 30 Z. WHITE	VIS ENTIÈREMENT FILETÉE DIN 933 PG CL 8.8 M12 X 30 Z. BLANC	VOLLGEWINDESCHRAUBE DIN 933 PG CL 8.8 M12 X 30 Z. WEIß	TORNILLO TOTALMENTE ROSCADO DIN 933 CL 8.8 M12 X 30 GALVANIZADO BLANCO
BV174	BV017400	NR	VITE TE TUTTO FILETTO PG DIN 933 CL 8.8 M5 X 45 Z.BIANCA	SCREW ALL THREAD DIN 933 PG CL 8.8 M5 X 45 Z. WHITE	VIS ENTIÈREMENT FILETÉE DIN 933 PG CL 8.8 M5 X 45 Z. BLANC	VOLLGEWINDESCHRAUBE DIN 933 PG CL 8.8 M5 X 45 Z. WEIß	TORNILLO TOTALMENTE ROSCADO DIN 933 CL 8.8 M5 X 45 GALVANIZADO BLANCO
BV175	BV017500	NR	VITE TE PARZIALE FILETTO PG DIN 931 CL 8.8 M 12 X 80 Z.BIANCA	SCREW PARTIAL THREAD DIN 931 PG CL 8.8 M12 X 80 Z. WHITE	VIS FILETÉE DIN 931 PG CL 8.8 M12 X 80 Z. BLANC	VOLLGEWINDESCHRAUBE DIN 931 PG CL 8.8 M12 X 80 Z. WEIßE	VIS ROSCADO DIN 931 CL 8.8 M12 X 80 GALVANIZADO BLANCO
BV176	BV017600	NR	VITE TCEI PG DIN 912 CL 8.8 M 6 X 25 Z.BIANCA	SCREW DIN 912 CL 8.8 M6 X 25	VIS DIN 912 CL 8.8 M6 X 25	SCHRAUBE DIN 912 CL 8.8 M6 X 25	TORNILLO TCEI PG DIN 912 CL 8.8 M6 X 25
BV177	BV017700	NR	VITE TE PARZIALE FILETTO PG DIN 931 CL 8.8 M 12 X 85 Z.BIANCA	SCREW PARTIAL THREAD DIN 931 PG CL 8.8 M12 X 85 Z. WHITE	VIS FILETÉE DIN 931 PG CL 8.8 M12 X 85 Z. BLANC	VOLLGEWINDESCHRAUBE DIN 931 PG CL 8.8 M12 X 85 Z. WEIßE	TORNILLO ROSCADO DIN 931 CL 8.8 M12 X 85 GALVANIZADO BLANCO
BV178	BV017800	NR	VITE TE TUTTO FILETTO PG DIN 933 CL 8.8 M8 X 90 Z.BIANCA	SCREW ALL THREAD DIN 933 PG CL 8.8 M8 X 90 Z. WHITE	VIS ENTIÈREMENT FILETÉE DIN 933 PG CL 8.8 M8 X 90 Z. BLANC	VOLLGEWINDESCHRAUBE DIN 933 PG CL 8.8 M8 X 90 Z. WEIßE	TORNILLO TOTALMENTE ROSCADO DIN 933 CL 8.8 M8 X 90 GALVANIZADO BLANCO
BV179	BV017900	NR	VITE TE TUTTO FILETTO PG DIN 933 CL 8.8 M5 X 40 Z.BIANCA	SCREW ALL THREAD DIN 933 PG CL 8.8 M5 X 40 Z. WHITE	VIS ENTIÈREMENT FILETÉE DIN 933 PG CL 8.8 M5 X 40 Z. BLANC	VOLLGEWINDESCHRAUBE DIN 933 PG CL 8.8 M5 X 40 Z. WEIßE	TORNILLO TOTALMENTE ROSCADO PG DIN 933 CL 8.8 M5 X 40 GALVANIZADO BLANCO
BV180	BV018000	NR	VITE TE TUTTO FILETTO PG DIN 933 CL 8.8 M6 X 75 Z.BIANCA	SCREW ALL THREAD DIN 933 PG CL 8.8 M6 X 75 Z. WHITE	VIS ENTIÈREMENT FILETÉE DIN 933 PG CL 8.8 M6 X 75 Z. BLANC	VOLLGEWINDESCHRAUBE DIN 933 PG CL 8.8 M6 X 75 Z. WEIß	TORNILLO TOTALMENTE ROSCADO DIN 933 CL 8.8 M6 X 75 GALVANIZADO BLANCO
BV182	BV018200	NR	VITE TE TUTTO FILETTO PG DIN 933 CL 10.9 M 16 X 70 Z.BIANCA	SCREW ALL THREAD DIN 933 PG CL 10.9 M 16 X 70 Z. WHITE	VIS ENTIÈREMENT FILETÉE DIN 933 CL 10.9 M 16 X 70 GALVANISÉE BLANCHE	VOLLGEWINDESCHRAUBE DIN 933 PG CL 10.9 M 16 X 70 Z. WEIß	TORNILLO TOTALMENTE FILETADO DIN 933 CL 10.9 M 16 X 70 TOTALMENTE ROSCADO
BV183	BV018300	NR	VITE TE TUTTO FILETTO PG DIN 933 CL 8.8 M5 X 10 Z.BIANCA	SCREW ALL THREAD DIN 933 PG CL 8.8 M5 X 10 Z. WHITE	VIS ENTIÈREMENT FILETÉE DIN 933 PG CL 8.8 M5 X 10 Z. BLANC	VOLLGEWINDESCHRAUBE DIN 933 PG CL 8.8 M5 X 10 Z. WEIß	TORNILLO TOTALMENTE ROSCADO DIN 933 CL 8.8 M5 X 10 GALVANIZADO BLANCO









POS	Codice	U.M.	 Descrizione	 Description	 Designation	 Benennung	 Descripción
BV184	BV018400	NR	VITE TE TUTTO FILETTO PG DIN 933 CL 8.8 M10 X 16 Z.BIANCA	SCREW ALL THREAD DIN 933 PG CL 8.8 M10 X 16 Z. WHITE	VIS ENTIÈREMENT FILETÉE DIN 933 PG CL 8.8 M10 X 16 Z. BLANC	VOLLGEWINDESCHRAUBE DIN 933 PG CL 8.8 M10 X 16 Z. WEIß	TORNILLO TOTALMENTE ROSCADO DIN 933 CL 8.8 M10 X 16 GALVANIZADO BLANCO
BV185	BV018500	NR	VITE TCEI PG DIN 912 CL 8.8 M 8 X 55 Z.BIANCA	SCREW DIN 912 CL 8.8 M8 X 55	VIS DIN 912 CL 8.8 M8 X 55	SCHRAUBE DIN 912 CL 8.8 M8 X 55	TORNILLO DIN 912 CL 8.8 M8 X 55
BV186	BV018600	NR	VITE TCEI PG DIN 912 CL 12.9 M10 X 30 GEOMET 321A	SCREW DIN 912 CL 12.9 M10 X 30 GEOMET 321A	VIS DIN 912 CL 12.9 M10 X 30 GEOMET 321A	SCHRAUBE DIN 912 CL 12.9 M10 X 30 GEOMET 321A	TORNILLO DIN 912 CL 12.9 M10 X 30 GEOMET 321A
BV187	BV018700	NR	VITE TCEI PG DIN 912 CL 12.9 M14 X 40 GEOMET 321A	SCREW DIN 912 CL 12.9 M14 X 40 GEOMET 321A	VIS TCEI PG DIN 912 CL 12.9 M14 X 40 GEOMET 321A	SCHRAUBE DIN 912 CL 12.9 M14 X 40 GEOMET 321A	TORNILLO DIN 912 CL 12.9 M14 X 40 GEOMET 321A
BV188	BV018800	NR	VITE TE TUTTO FILETTO PG DIN 933 CL 8.8 M 12 X 60 Z.BIANCA	SCREW ALL THREAD DIN 933 PG CL 8.8 M12 X 60 Z. WHITE	VIS ENTIÈREMENT FILETÉE DIN 933 PG CL 8.8 M12 X 60 Z. BLANC	VOLLGEWINDESCHRAUBE DIN 933 PG CL 8.8 M12 X 60 Z. WEIßE	VIS TOTALMENTE ROSCADO DIN 933 CL 8.8 M12 X 60 GALVANIZADO BLANCO
BV189	BV018900	NR	VITE TE TUTTO FILETTO PG DIN 933 CL 8.8 M 12 X 55 Z.BIANCA	SCREW ALL THREAD DIN 933 PG CL 8.8 M12 X 55 Z. WHITE	VIS ENTIÈREMENT FILETÉE DIN 933 PG CL 8.8 M12 X 55 Z. BLANC	VOLLGEWINDESCHRAUBE DIN 933 PG CL 8.8 M12 X 55 Z. WEIßE	VIS TOTALMENTE ROSCADO DIN 933 CL 8.8 M12 X 55 GALVANIZADO BLANCO
BV190	BV019000	NR	VITE TE TUTTO FILETTO PG DIN 933 CL 8.8 M 12 X 50 Z.BIANCA	SCREW ALL THREAD DIN 933 PG CL 8.8 M12 X 50 Z. WHITE	VIS ENTIÈREMENT FILETÉE DIN 933 PG CL 8.8 M12 X 50 Z. BLANC	VOLLGEWINDESCHRAUBE DIN 933 PG CL 8.8 M12 X 50 Z. WEIßE	VIS TOTALMENTE ROSCADO DIN 933 CL 8.8 M12 X 50 GALVANIZADO BLANCO
BV191	BV019100	NR	VITE TE TUTTO FILETTO PG DIN 933 CL 8.8 M 16 X 50 Z.BIANCA	SCREW ALL THREAD DIN 933 PG CL 8.8 M16 X 50 Z. WHITE	VIS ENTIÈREMENT FILETÉE DIN 933 PG CL 8.8 M16 X 50 Z. BLANC	VOLLGEWINDESCHRAUBE DIN 933 PG CL 8.8 M16 X 50 Z. WEIßE	VIS TOTALMENTE ROSCADO DIN 933 CL 8.8 M16 X 50 GALVANIZADO BLANCO
BV192	BV019200	NR	VITE TE TUTTO FILETTO PG DIN 933 CL 8.8 M 16 X 55 Z.BIANCA	SCREW ALL THREAD DIN 933 PG CL 8.8 M16 X 55 Z. WHITE	VIS ENTIÈREMENT FILETÉE DIN 933 PG CL 8.8 M16 X 55 Z. BLANC	VOLLGEWINDESCHRAUBE DIN 933 PG CL 8.8 M16 X 55 Z. WEIßE	VIS TOTALMENTE ROSCADO DIN 933 CL 8.8 M16 X 55 GALVANIZADO BLANCO
BV193	BV019300	NR	VITE TE PARZIALE FILETTO PG DIN 931 CL 8.8 M 10 X 55 Z.BIANCA	SCREW PARTIAL THREAD DIN 931 PG CL 8.8 M 10 X 55 Z. WHITE	VIS PARTIELLEMENT FILETÉE DIN 931 PG CL 8.8 M 10 X 55 Z. BLANC	TEILGEWINDESCHRAUBE DIN 931 PG CL 8.8 M 10 X 55 Z. WEIß	TORNILLO PARCIALMENTE ROSCADO PG DIN 931 CL 8.8 M 10 X 55 GALVANIZADO BLANCO
BV194	BV019400	NR	VITE TE PARZIALE FILETTO PG DIN 931 CL 8.8 M 16 X 230 Z.BIANCA	SCREW PARTIAL THREAD DIN 931 PG CL 8.8 M 16 X 230 Z. WHITE	VIS PARTIELLEMENT FILETÉE DIN 931 PG CL 8.8 M 16 X 230 Z. BLANC	TEILGEWINDESCHRAUBE DIN 931 PG CL 8.8 M 16 X 230 Z. WEIß	TORNILLO PARCIALMENTE ROSCADO PG DIN 931 CL 8.8 M 16 X 230 GALVANIZADO BLANCO





POS	Codice	U.M.	 Descrizione	 Description	 Designation	 Benennung	 Descripción
BV195	BV019500	NR	VITE TE PARZIALE FILETTO PG DIN 931 CL 8.8 M 6 X 50 Z.BIANCA	SCREW PARTIAL THREAD DIN 931 PG CL 8.8 M 6 X 50 Z. WHITE	VIS PARTIELLEMENT FILETÉE DIN 931 PG CL 8.8 M 6 X 50 Z. BLANC	TEILGEWINDESCHRAUBE DIN 931 PG CL 8.8 M 6 X 50 Z. WEIß	TORNILLO PARCIALMENTE ROSCADO PG DIN 931 CL 8.8 M 6 X 50 GALVANIZADO BLANCO
BV196	BV019600	NR	VITE TE PARZIALE FILETTO PG DIN 931 CL 8.8 M 6 X 65 Z.BIANCA	SCREW PARTIAL THREAD DIN 931 PG CL 8.8 M 6 X 65 Z. WHITE	VIS PARTIELLEMENT FILETÉE DIN 931 PG CL 8.8 M 6 X 65 Z. BLANC	TEILGEWINDESCHRAUBE DIN 931 PG CL 8.8 M 6 X 65 Z. WEIß	TORNILLO PARCIALMENTE ROSCADO PG DIN 931 CL 8.8 M 6 X 65 GALVANIZADO BLANCO
BV197	BV019700	NR	VITE TE PARZIALE FILETTO PG DIN 931 CL 8.8 M 8 X 45 Z.BIANCA	SCREW PARTIAL THREAD DIN 931 PG CL 8.8 M 8 X 45 Z. WHITE	VIS PARTIELLEMENT FILETÉE DIN 931 PG CL 8.8 M 8 X 45 Z. BLANC	TEILGEWINDESCHRAUBE DIN 931 PG CL 8.8 M 8 X 45 Z. WEIß	TORNILLO PARCIALMENTE ROSCADO PG DIN 931 CL 8.8 M 8 X 45 GALVANIZADO BLANCO
BV198	BV019800	NR	VITE TE PARZIALE FILETTO PG DIN 931 CL 8.8 M 8 X 55 Z.BIANCA	SCREW PARTIAL THREAD DIN 931 PG CL 8.8 M 8 X 55 Z. WHITE	VIS PARTIELLEMENT FILETÉE DIN 931 PG CL 8.8 M 8 X 55 Z. BLANC	TEILGEWINDESCHRAUBE DIN 931 PG CL 8.8 M 8 X 55 Z. WEIß	TORNILLO PARCIALMENTE ROSCADO PG DIN 931 CL 8.8 M 8 X 55 GALVANIZADO BLANCO
BV199	BV019900	NR	VITE TE PARZIALE FILETTO PG DIN 931 CL 8.8 M 8 X 60 Z.BIANCA	SCREW PARTIAL THREAD DIN 931 PG CL 8.8 M 8 X 60 Z. WHITE	VIS PARTIELLEMENT FILETÉE DIN 931 PG CL 8.8 M 8 X 60 Z. BLANC	TEILGEWINDESCHRAUBE DIN 931 PG CL 8.8 M 8 X 60 Z. WEIß	TORNILLO PARCIALMENTE ROSCADO PG DIN 931 CL 8.8 M 8 X 60 GALVANIZADO BLANCO
BV200	BV020000	NR	VITE TE TUTTO FILETTO PG DIN 933 CL 10.9 M 16 X 40	SCREW ALL THREAD DIN 933 PG CL 10.9 M 16 X 40	VIS ENTIÈREMENT FILETÉE DIN 933 CL 10.9 M 16 X 40	VOLLGEWINDESCHRAUBE DIN 933 PG CL 10.9 M 16 X 40	TORNILLO TOTALMENTE FILETADO DIN 933 CL 10.9 M 16 X 40
BV201	BV020100	NR	VITE TSPEI PG DIN 7991 CL 10.9 M16 X 45 Z.BIANCA	TSPEI PG SCREW DIN 7991 CL 10.9 M16 X 45 Z. WHITE	VIS DIN 7991 CL 10.9 M16 X 45 Z. WHITE	TSPEI PG SCHRAUBE DIN 7991 CL 10.9 M16 X 45 Z. WEIß	TORNILLO TSPEI PG DIN 7991 CL 10.9 M 16 X 45 GALVANIZADO BLANCO
BV202	BV020200	NR	VITE TCEI PG DIN 912 CL 12.9 M3 X 12 ZINC. IRIDESCENTE FE/ZN5IVS	SCREW DIN 912 CL 12.9 M3 X 12 ZINC. IRIDESCENTE FE/ZN5IVS	VIS DIN 912 CL 12.9 M3 X 12 ZINC. IRIDESCENTE FE/ZN5IVS	SCHRAUBE DIN 912 CL 12.9 M3 X 12 ZINC. IRIDESCENTE FE/ZN5IVS	TORNILLO DIN 912 CL 12.9 M3 X 12 ZINC. IRIDESCENTE FE/ZN5IVS
BV203	BV020300	NR	VITE TC CROCE PG DIN 7985 CL 4.8 M M 3 X 5 Z.BIANCA	SCREW DIN 7985 CL 4.8 M M 3 X 5	VIS CROIX DIN 7985 CL 4.8 M M 3 X 5 GALVANISATION BLANCHE	SCHRAUBE	TORNILLO
BV204	BV020400	NR	VITE TC CROCE PG DIN 7985 CL 4.8 M M 3 X 8 Z.BIANCA	SCREW DIN 7985 CL 4.8 M M 3 X 8	VIS CROIX DIN 7985 CL 4.8 M M 3 X 8 GALVANISATION BLANCHE	SCHRAUBE	TORNILLO
BV205	BV020500	NR	VITE TTQST DIN 603 CL 4.8 M 8 X 35 Z.BIANCA	TTQST SCREW DIN 603 CL 4.8 M 8 X 35 Z. WHITE			





POS	Codice	U.M.	 Descrizione	 Description	 Designation	 Benennung	 Descripción
BV206	BV020600	NR	VITE TC CROCE PG DIN 7985 CL 4.8 M M 5 X 80 Z.BIANCA	SCREW DIN 7985 CL 4.8 M M 5 X 80	VIS CROIX DIN 7985 CL 4.8 M M 5 X 80 GALVANISATION BLANCHE	SCHRAUBE	TORNILLO
BV207	BV020700	NR	VITE TE PARZIALE FILETTO PG DIN 931 CL 8.8 M 10 X 80 Z.BIANCA	SCREW PARTIAL THREAD DIN 931 PG CL 8.8 M 10 X 80 Z. WHITE	VIS PARTIELLEMENT FILETÉE DIN 931 PG CL 8.8 M 10 X 80 Z. BLANC	TEILGEWINDESCHRAUBE DIN 931 PG CL 8.8 M 10 X 80 Z. WEIß	TORNILLO PARCIALMENTE ROSCADO PG DIN 931 CL 8.8 M 10 X 80 GALVANIZADO BLANCO
BV208	BV020800	NR	VITE TE TUTTO FILETTO PG DIN 933 CL 8.8 M 16 X 35 Z.D.BIANCA	SCREW ALL THREAD DIN 933 PG CL 8.8 M 16 X 35 ZD WHITE	VIS ENTIÈREMENT FILETÉE DIN 933 CL 8.8 M 16 X 35 GALVANISATION BLANCHE	SCHRAUBE	TORNILLO
BV209	BV020900	NR	VITE TE PARZIALE FILETTO PG DIN 931 CL 8.8 M 10 X 95 Z.BIANCA	SCREW PARTIAL THREAD DIN 931 PG CL 8.8 M 10 X 95 Z. WHITE	VIS PARTIELLEMENT FILETÉE DIN 931 PG CL 8.8 M 10 X 95 Z. BLANC	TEILGEWINDESCHRAUBE DIN 931 PG CL 8.8 M 10 X 95 Z. WEIß	TORNILLO PARCIALMENTE ROSCADO PG DIN 931 CL 8.8 M 10 X 95 GALVANIZADO BLANCO
BV210	BV021000	NR	VITE TE TUTTO FILETTO PG DIN 933 CL 8.8 M 6 X 14 Z.D.BIANCA	SCREW ALL THREAD DIN 933 PG CL 8.8 M 6 X 14 ZD WHITE	VIS ENTIÈREMENT FILETÉE DIN 933 CL 8.8 M 6 X 14 GALVANISATION BLANCHE	SCHRAUBE	TORNILLO
BV211	BV021100	NR	VITE TE TUTTO FILETTO PG DIN 933 CL 8.8 M 12 X 25 Z.D.BIANCA	SCREW ALL THREAD DIN 933 PG CL 8.8 M 12 X 25 ZD WHITE	VIS ENTIÈREMENT FILETÉE DIN 933 CL 8.8 M 12 X 25 GALVANISATION BLANCHE	SCHRAUBE	TORNILLO
BV212	BV021200	NR	VITE TE TUTTO FILETTO PG DIN 933 CL 8.8 M 4 X 14 Z.D.BIANCA	SCREW ALL THREAD DIN 933 PG CL 8.8 M 4 X 14 ZD WHITE	VIS ENTIÈREMENT FILETÉE DIN 933 CL 8.8 M 4 X 14 GALVANISATION BLANCHE	SCHRAUBE	TORNILLO
BV213	BV021300	NR	VITE TE TUTTO FILETTO PG DIN 933 CL 10.9 M 16 X 60	SCREW ALL THREAD DIN 933 PG CL 10.9 M 16 X 60	VIS ENTIÈREMENT FILETÉE DIN 933 CL 10.9 M 16 X 60	SCHRAUBE	TORNILLO
BV214	BV021400	NR	VITE TE PARZIALE FILETTO PG DIN 931 CL 8.8 M 6 X 100 Z.BIANCA	SCREW PARTIAL THREAD DIN 931 PG CL 8.8 M 6 X 100 Z. WHITE	VIS PARTIELLEMENT FILETÉE DIN 931 PG CL 8.8 M 6 X 100 Z. BLANC	TEILGEWINDESCHRAUBE DIN 931 PG CL 8.8 M 6 X 100 Z. WEIß	TORNILLO PARCIALMENTE ROSCADO PG DIN 931 CL 8.8 M 6 X 100 GALVANIZADO BLANCO
BV215	BV021500	NR	VITE TE PARZIALE FILETTO PG DIN 931 CL 10.9 M 16 X 110	SCREW PARTIAL THREAD DIN 931 PG CL 10.9 M 16 X 110	VIS PARTIELLEMENT FILETÉE DIN 931 CL 10.9 M 16 X 110	SCHRAUBE	TORNILLO
BV216	BV021600	NR	VITE TE PARZIALE FILETTO PG DIN 931 CL 10.9 M 16 X 240 Z.D.BIANCA	SCREW PARTIAL THREAD DIN 931 PG CL 10.9 M 16 X 240 ZD WHITE	VIS PARTIELLEMENT FILETÉE DIN 931 CL 10.9 M 16 X 240 GALVANISATION BLANCHE	SCHRAUBE	TORNILLO

POS	Codice	U.M.	 Descrizione	 Description	 Designation	 Benennung	 Descripción
BV217	BV021700	NR	VITE TSPEI PG DIN 7991 CL 10.9 M 8 X 30 Z.BIANCA	TSPEI PG SCREW DIN 7991 CL 10.9 M8 X 30 Z. WHITE	VIS TSPEI PG DIN 7991 CL 10.9 M 8 X 30 GALVANISATION BLANCHE	SCHRAUBE	TORNILLO
BV218	BV021800	NR	VITE TSPEI PG DIN 7991 CL 10.9 M 5 X 6 Z.BIANCA	TSPEI PG SCREW DIN 7991 CL 10.9 M5 X 6 Z. WHITE	VIS TSPEI PG DIN 7991 CL 10.9 M 5 X 6 GALVANISATION BLANCHE	SCHRAUBE	TORNILLO
BV219	BV021900	NR	VITE TSPEI PG DIN 7991 CL 10.9 M 5 X 70 Z.BIANCA	TSPEI PG SCREW DIN 7991 CL 10.9 M5 X 70 Z. WHITE	VIS TSPEI PG DIN 7991 CL 10.9 M 5 X 70 GALVANISATION BLANCHE	SCHRAUBE	TORNILLO
BV220	BV022000	NR	VITE TSPEI PG DIN 7991 CL 10.9 M 12 X 35 Z.BIANCA	TSPEI PG SCREW DIN 7991 CL 10.9 M12 X 35 Z. WHITE	VIS TSPEI PG DIN 7991 CL 10.9 M 12 X 35 GALVANISATION BLANCHE	SCHRAUBE	TORNILLO
BV221	BV022100	NR	VITE TCEI PG DIN 912 CL 12.9 M10 X 20 GEOMET 321A	SCREW DIN 912 CL 12.9 M10 X 20 GEOMET 321A	VIS DIN 912 CL 12.9 M10 X 20 GEOMET 321A	SCHRAUBE DIN 912 CL 12.9 M10 X 20 GEOMET 321A	TORNILLO DIN 912 CL 12.9 M10 X 20 GEOMET 321A
BV222	BV022200	NR	VITE TCEI PG DIN 912 CL 12.9 M8 X 90 GEOMET 321A	SCREW DIN 912 CL 12.9 M8 X 90 GEOMET 321A	VIS DIN 912 CL 12.9 M8 X 90 GEOMET 321A	SCHRAUBE DIN 912 CL 12.9 M8 X 90 GEOMET 321A	TORNILLO DIN 912 CL 12.9 M8 X 90 GEOMET 321A
BV223	BV022300	NR	VITE TCEI PG DIN 912 CL 12.9 M3 X 5 ZINC.	SCREW DIN 912 CL 12.9 M3 X 5 ZINC.	VIS DIN 912 CL 12.9 M3 X 5 ZINC.	SCHRAUBE DIN 912 CL 12.9 M3 X 5 ZINC.	TORNILLO DIN 912 CL 12.9 M3 X 5 ZINC.
BV224	BV022400	NR	VITE TBEI PG ISO 7380 CL 10.9 M 8 X 22 Z.BIANCA	HEX SOCKET SCREW ISO 7380 PG CL 10.9 M 8 X 22 Z. WHITE	VIS ISO 7380 PG CL 10.9 M 8 X 22 Z. BLANC	SCHRAUBE ISO 7380 PG CL 10.9 M 8 X 22 Z. WEIß	TORNILLO TBEI PG ISO 7380 CL 10.9 M 8 X 22 GALVANIZADO BLANCO
BV225	BV022500	NR	VITE TE PARZIALE FILETTO PG DIN 931 CL 8.8 M 10 X 100 Z.BIANCA	SCREW PARTIAL THREAD DIN 931 PG CL 8.8 M 10 X 100 Z. WHITE	VIS PARTIELLEMENT FILETÉE DIN 931 PG CL 8.8 M 10 X 100 Z. BLANC	TEILGEWINDESCHRAUBE DIN 931 PG CL 8.8 M 10 X 100 Z. WEIß	TORNILLO PARCIALMENTE ROSCADO PG DIN 931 CL 8.8 M 10 X 100 GALVANIZADO BLANCO
BV226	BV022600	NR	VITE TE PARZIALE FILETTO PG DIN 931 CL 8.8 M 10 X 110 Z.BIANCA	SCREW PARTIAL THREAD DIN 931 PG CL 8.8 M 10 X 110 Z. WHITE	VIS PARTIELLEMENT FILETÉE DIN 931 PG CL 8.8 M 10 X 110 Z. BLANC	TEILGEWINDESCHRAUBE DIN 931 PG CL 8.8 M 10 X 110 Z. WEIß	TORNILLO PARCIALMENTE ROSCADO PG DIN 931 CL 8.8 M 10 X 110 GALVANIZADO BLANCO
BV227	BV022700	NR	VITE TE PARZIALE FILETTO PG DIN 931 CL 10.9 M 12 X 45 Z.D.BIANCA	SCREW PARTIAL THREAD DIN 931 PG CL 10.9 M 12 X 45 ZD WHITE	VIS PARTIEL FILETÉE DIN 931 CL 10.9 M 12 X 45 GALVANISATION BLANCHE	SCHRAUBE	TORNILLO

POS	Codice	U.M.	 Descrizione	 Description	 Designation	 Benennung	 Descripción
BV228	BV022800	NR	VITE TE TUTTO FILETTO PG DIN 933 CL 10.9 M 14 X 35 Z.D.BIANCA	SCREW ALL THREAD DIN 933 PG CL 10.9 M 14 X 35 ZD WHITE	VIS ENTIÈREMENT FILETÉE DIN 933 CL 10.9 M 14 X 35 GALVANISATION BLANCHE	SCHRAUBE	TORNILLO
BV229	BV022900	NR	VITE TSPEI PG DIN 7991 CL 10.9 M 12 X 30 Z.BIANCA	TSPEI PG SCREW DIN 7991 CL 10.9 M12 X 30 Z. WHITE	VIS TSPEI PG DIN 7991 CL 10.9 M 12 X 30 GALVANISATION BLANCHE	SCHRAUBE	TORNILLO
BV230	BV023000	NR	VITE TE FLANGIATA TUTTO FILETTO PG DIN 6921 CL 8.8 M 5 X 12 ZINCONICKEL NERO +SIGILLANTE	FLANGE SCREW ALL THREAD DIN 6921 PG CL 8.8 M 5 X 12 ZINCNICKEL BLACK +SEALANT	VIS	SCHRAUBE	TORNILLO
BV231	BV023100	NR	VITE TE FLANGIATA TUTTO FILETTO PG DIN 6921 CL 8.8 M 6 X 16 ZINCONICKEL NERO +SIGILLANTE	FLANGE SCREW ALL THREAD DIN 6921 PG CL 8.8 M 6 X 16 ZINCNICKEL BLACK +SEALANT	VIS	SCHRAUBE	TORNILLO
BV232	BV023200	NR	VITE TE TUTTO FILETTO PG DIN 933 CL 8.8 M 5 X 25 Z.D.BIANCA	SCREW ALL THREAD DIN 933 PG CL 8.8 M 5 X 25 ZD WHITE	VIS ENTIÈREMENT FILETÉE DIN 933 CL 8.8 M 5 X 25 GALVANISATION BLANCHE	SCHRAUBE	TORNILLO
BV233	BV023300	NR	VITE TE TUTTO FILETTO PG DIN 933 CL 8.8 M 8 X 130 Z.D.BIANCA	SCREW ALL THREAD DIN 933 PG CL 8.8 M 8 X 130 ZD WHITE	VIS ENTIÈREMENT FILETÉE DIN 933 CL 8.8 M 8 X 130 GALVANISATION BLANCHE	SCHRAUBE	TORNILLO
BV234	BV023400	NR	VITE TBEI PG ISO 7380 CL 10.9 M 10 X 30 Z.BIANCA	HEX SOCKET SCREW ISO 7380 PG CL 10.9 M 10 X 30 Z. WHITE	VIS ISO 7380 PG CL 10.9 M 10 X 30 Z. BLANC	SCHRAUBE ISO 7380 PG CL 10.9 M10 X 30 Z. WEIß	TORNILLO TBEI PG ISO 7380 CL 10.9 M 10 X 30 GALVANIZADO BLANCO
BV235	BV023500	NR	VITE TE TUTTO FILETTO PG DIN 933 CL 10.9 M 16 X 35 Z.D.BIANCA	SCREW ALL THREAD DIN 933 PG CL 10.9 M 16 X 35 ZD WHITE	VIS ENTIÈREMENT FILETÉE DIN 933 CL 10.9 M 16 X 35 GALVANISATION BLANCHE	SCHRAUBE	TORNILLO
BV236	BV023600	NR	VITE TE PARZIALE FILETTO PG DIN 931 CL 8.8 M 6 X 45 Z.BIANCA	SCREW PARTIAL THREAD DIN 931 PG CL 8.8 M 6 X 45 Z. WHITE	VIS PARTIELLEMENT FILETÉE DIN 931 PG CL 8.8 M 6 X 45 Z. BLANC	TEILGEWINDESCHRAUBE DIN 931 PG CL 8.8 M 6 X 45 Z. WEIß	TORNILLO PARCIALMENTE ROSCADO PG DIN 931 CL 8.8 M 6 X 45 GALVANIZADO BLANCO
BV237	BV023700	NR	VITE TE TUTTO FILETTO PG DIN 933 CL 10.9 M 12 X 30 Z.D.BIANCA	SCREW ALL THREAD DIN 933 PG CL 10.9 M 12 X 30 ZD WHITE	VIS ENTIÈREMENT FILETÉE DIN 933 CL 10.9 M 12 X 30 GALVANISATION BLANCHE	SCHRAUBE	TORNILLO

POS	Codice	U.M.	 Descrizione	 Description	 Designation	 Benennung	 Descripción
BV238	BV023800	NR	VITE TE PARZIALE FILETTO PG DIN 931 CL 8.8 M 16 X 90 Z.BIANCA	SCREW PARTIAL THREAD DIN 931 PG CL 8.8 M 16 X 90 Z. WHITE	VIS PARTIELLEMENT FILETÉE DIN 931 PG CL 8.8 M 16 X 90 Z. BLANC	TEILGEWINDESCHRAUBE DIN 931 PG CL 8.8 M 16 X 90 Z. WEIß	TORNILLO PARCIALMENTE ROSCADO PG DIN 931 CL 8.8 M 16 X 90 GALVANIZADO BLANCO
BV239	BV023900	NR	VITE TE PARZIALE FILETTO PG DIN 931 CL 8.8 M 12 X 65 Z.BIANCA	SCREW PARTIAL THREAD DIN 931 PG CL 8.8 M 12 X 65 Z. WHITE	VIS PARTIELLEMENT FILETÉE DIN 931 PG CL 8.8 M 12 X 65 Z. BLANC	TEILGEWINDESCHRAUBE DIN 931 PG CL 8.8 M 12 X 65 Z. WEIß	TORNILLO PARCIALMENTE ROSCADO PG DIN 931 CL 8.8 M 12 X 65 GALVANIZADO BLANCO
BV240	BV024000	NR	VITE TC CROCE PG DIN 7985 CL 4.8 M 5 X 20 Z.BIANCA	SCREW DIN 7985 CL 4.8 M 5 X 20	VIS CROIX DIN 7985 CL 4.8 M 5 X 20 GALVANISATION BLANCHE	SCHRAUBE	TORNILLO
BV241	BV024100	NR	VITE TSPEI PG DIN 7991 CL 10.9 M 10 X 35 Z.BIANCA	TSPEI PG SCREW DIN 7991 CL 10.9 M 10 X 35 Z. WHITE	VIS TSPEI PG DIN 7991 CL 10.9 M 10 X 35 GALVANISATION BLANCHE	SCHRAUBE	TORNILLO
BV242	BV024200	NR	VITE TSPEI PG DIN 7991 CL 10.9 M 6 X 12 Z.BIANCA	TSPEI PG SCREW DIN 7991 CL 10.9 M 6 X 12 Z. WHITE	VIS TSPEI PG DIN 7991 CL 10.9 M 6 X 12 GALVANISATION BLANCHE	SCHRAUBE	TORNILLO
BV243	BV024300	NR	VITE TE PARZIALE FILETTO PG DIN 931 CL 8.8 M 12 X 150 Z.BIANCA	SCREW PARTIAL THREAD DIN 931 PG CL 8.8 M 12 X 150 Z. WHITE	VIS PARTIELLEMENT FILETÉE DIN 931 PG CL 8.8 M 12 X 150 Z. BLANC	TEILGEWINDESCHRAUBE DIN 931 PG CL 8.8 M 12 X 150 Z. WEIß	TORNILLO PARCIALMENTE ROSCADO PG DIN 931 CL 8.8 M 12 X 150 GALVANIZADO BLANCO
BV244	BV024400	NR	VITE TCEI PG DIN 912 CL 8.8 M5 X 50 ZINGATA BIANCA	SCREW DIN 912 CL 8.8 M5 X 50	VIS DIN 912 CL 8.8 M5 X 50	SCHRAUBE DIN 912 CL 8.8 M5 X 50	TORNILLO DIN 912 CL 8.8 M5 X 50
BV245	BV024500	NR	VITE TE PARZIALE FILETTO PG DIN 931 CL 8.8 M 8 X 110 Z.BIANCA	SCREW PARTIAL THREAD DIN 931 PG CL 8.8 M 8 X 110 Z. WHITE	VIS PARTIELLEMENT FILETÉE DIN 931 PG CL 8.8 M 8 X 110 Z. BLANC	TEILGEWINDESCHRAUBE DIN 931 PG CL 8.8 M 8 X 110 Z. WEIß	TORNILLO PARCIALMENTE ROSCADO PG DIN 931 CL 8.8 M 8 X 110 GALVANIZADO BLANCO
BV246	BV024600	NR	VITE TE PARZIALE FILETTO PG DIN 931 CL 8.8 M 8 X 40 Z.BIANCA	SCREW PARTIAL THREAD DIN 931 PG CL 8.8 M 8 X 40 Z. WHITE	VIS PARTIELLEMENT FILETÉE DIN 931 PG CL 8.8 M 8 X 40 Z. BLANC	TEILGEWINDESCHRAUBE DIN 931 PG CL 8.8 M 8 X 40 Z. WEIß	TORNILLO PARCIALMENTE ROSCADO PG DIN 931 CL 8.8 M 8 X 40 GALVANIZADO BLANCO
BV247	BV024700	NR	VITE TE TUTTO FILETTO PG DIN 933 CL 8.8 M 5 X 50 Z.D.BIANCA	SCREW ALL THREAD DIN 933 PG CL 8.8 M 5 X 50 ZD WHITE	VIS ENTIÈREMENT FILETÉE DIN 933 CL 8.8 M 5 X 50 GALVANISATION BLANCHE	SCHRAUBE	TORNILLO
BV248	BV024800	NR	VITE TCEI PG DIN 912 CL 8.8 M5 X 18 Z. BIANCA	SCREW DIN 912 CL 8.8 M5 X 18 Z. WITHE	VIS DIN 912 CL 8.8 M5 X 18	SCHRAUBE DIN 912 CL 8.8 M5 X 18	TORNILLO DIN 912 CL 8.8 M5 X 18





POS	Codice	U.M.	 Descrizione	 Description	 Designation	 Benennung	 Descripción
BV249	BV024900	NR	VITE TSPEI PG DIN 7991 CL 10.9 M 5 X 65 Z.BIANCA	TSPEI PG SCREW DIN 7991 CL 10.9 M 5 X 65 Z. WHITE	VIS TSPEI PG DIN 7991 CL 10.9 M 5 X 65 GALVANISATION BLANCHE	SCHRAUBE	TORNILLO
BV251	BV025100	NR	VITE TSPEI PG DIN 7991 CL 10.9 M 8 X 35 Z.BIANCA	TSPEI PG SCREW DIN 7991 CL 10.9 M 8 X 35 Z. WHITE	VIS TSPEI PG DIN 7991 CL 10.9 M 8 X 35 GALVANISATION BLANCHE	SCHRAUBE	TORNILLO
BV252	BV025200	NR	VITE TE TUTTO FILETTO PG DIN 933 CL 10.9 M 12 X 40 Z.D.BIANCA	SCREW ALL THREAD DIN 933 PG CL 10.9 M 12 X 40 ZD WHITE	VIS ENTIÈREMENT FILETÉE DIN 933 CL 10.9 M 12 X 40 GALVANISATION BLANCHE	SCHRAUBE	TORNILLO
BV253	BV025300	NR	VITE TBEI PG ISO 7380 M 6 X 55 Z.BIANCA	HEX SOCKET SCREW ISO 7380 PG M 6 X 55 Z. WHITE	VIS ISO 7380 PG M 6 X 55 Z. BLANC	SCHRAUBE ISO 7380 PG M 6 X 55 Z. WEIß	TORNILLO TBEI PG ISO 7380 M 6 X 55 GALVANIZADO BLANCO
BV254	BV025400	NR	VITE TE TUTTO FILETTO PG DIN 933 CL 10.9 M 10 X 35 Z.D.BIANCA	SCREW ALL THREAD DIN 933 PG CL 10.9 M 10 X 35 ZD WHITE	VIS ENTIÈREMENT FILETÉE DIN 933 CL 10.9 M 10 X 35 GALVANISATION BLANCHE	SCHRAUBE	TORNILLO
BV255	BV025500	NR	VITE TE TUTTO FILETTO PG DIN 933 CL 12.9 M 14 X 55 Z.D.BIANCA	SCREW ALL THREAD DIN 933 PG CL 12.9 M 14 X 55 ZD WHITE	VIS ENTIÈREMENT FILETÉE DIN 933 CL 12.9 M 14 X 55 GALVANISATION BLANCHE	SCHRAUBE	TORNILLO
BV256	BV025600	NR	VITE TESTA SVASATA CROCE AUTOFILETTANTE 6 X 25	SCREW HEAD CROSS COUNTERSUNK SELF TAPPING 6 X 25			
BV257	BV025700	NR	VITE TE TUTTO FILETTO PG DIN 933 CL 8.8 M14 X 30 Z.BIANCA	SCREW ALL THREAD DIN 933 PG CL 8.8 M14 X 30 Z. WHITE	VIS ENTIÈREMENT FILETÉE DIN 933 PG CL 8.8 M14 X 30 Z. BLANC	VOLLGEWINDESCHRAUBE DIN 933 PG CL 8.8 M14 X 30 Z. WEIß	TORNILLO TOTALMENTE ROSCADO PG DIN 933 CL 8.8 M14 X 30 GALVANIZADO BLANCO
BV258	BV025800	NR	VITE TE TUTTO FILETTO PG DIN 933 CL 10.9 M 12 X 35 Z.D.BIANCA	SCREW ALL THREAD DIN 933 PG CL 10.9 M 12 X 35 ZD WHITE	VIS ENTIÈREMENT FILETÉE DIN 933 CL 10.9 M 12 X 35 GALVANISATION BLANCHE	SCHRAUBE	TORNILLO
BV259	BV025900	NR	VITE TE TUTTO FILETTO PG DIN 933 CL 8.8 M 16 X 45 Z.BIANCA	SCREW ALL THREAD DIN 933 PG CL 8.8 M16 X 45 Z. WHITE	VIS ENTIÈREMENT FILETÉE DIN 933 PG CL 8.8 M16 X 45 Z. BLANC	VOLLGEWINDESCHRAUBE DIN 933 PG CL 8.8 M16 X 45 Z. WEIßE	VIS TOTALMENTE ROSCADO DIN 933 CL 8.8 M16 X 45 GALVANIZADO BLANCO
BV260	BV026000	NR	VITE TCEI PG DIN 912 CL 10.9 M 12 X 30 ZINCATA BIANCA	SCREW DIN 912 CL 10.9 M 12 X 30	VIS DIN 912 CL 12.9 M 10 X 30	SCHRAUBE DIN 912 CL 10.9 M 12 X 30	TORNILLO TCEI PG DIN 912 CL 10.9 M 12 X 30
BV261	BV026100	NR	VITE TCEI PG DIN 912 CL 10.9 M 12 X 20 ZINCATA BIANCA	SCREW DIN 912 CL 10.9 M 12 X 20	VIS DIN 912 CL 12.9 M 10 X 20	SCHRAUBE DIN 912 CL 10.9 M 12 X 20	TORNILLO TCEI PG DIN 912 CL 10.9 M 12 X 20

POS	Codice	U.M.	 Descrizione	 Description	 Designation	 Benennung	 Descripción
BV262	BV026200	NR	VITE TCEI PG DIN 912 CL 12.9 M14 X 35 GEOMET 321A	SCREW DIN 912 CL 12.9 M14 X 35 GEOMET 321A	VIS TCEI PG DIN 912 CL 12.9 M14 X 35 GEOMET 321A	SCHRAUBE DIN 912 CL 12.9 M14 X 35 GEOMET 321A	TORNILLO DIN 912 CL 12.9 M14 X 35 GEOMET 321A
BV263	BV026300	NR	VITE TCEI PG DIN 912 CL 12.9 M14 X 3 GEOMET 321A	SCREW DIN 912 CL 12.9 M14 X 3 GEOMET 321A	VIS TCEI PG DIN 912 CL 12.9 M14 X 3 GEOMET 321A	SCHRAUBE DIN 912 CL 12.9 M14 X 3 GEOMET 321A	TORNILLO DIN 912 CL 12.9 M14 X 30 GEOMET 321A
BV264	BV026400	NR	VITE TSPEI PG DIN 7991 CL 10.9 M 12 X 25 Z.BIANCA	TSPEI PG SCREW DIN 7991 CL 10.9 M12 X 25 Z. WHITE	VIS TSPEI PG DIN 7991 CL 10.9 M 12 X 25 GALVANISATION BLANCHE	SCHRAUBE	TORNILLO
BV265	BV026500	NR	VITE TE PARZIALE FILETTO PG DIN 931 CL 10.9 M 16 X 180 GEOMET 321A	SCREW PARTIAL THREAD DIN 931 PG CL 10.9 M 16 X 180 GEOMET 321A	VIS PARTIELLEMENT FILETÉE DIN 931 CL 10.9 M 16 X 180 GEOMET 321A	SCHRAUBE	TORNILLO
BV266	BV026600	NR	VITE TE TUTTO FILETTO PG DIN 933 CL 8.8 M8 X 10 Z.BIANCA	SCREW ALL THREAD DIN 933 PG CL 8.8 M8 X 10 Z. WHITE	VIS ENTIÈREMENT FILETÉE DIN 933 PG CL 8.8 M8 X 10 Z. BLANC	VOLLGEWINDESCHRAUBE DIN 933 PG CL 8.8 M8 X 10 Z. WEIß	TORNILLO TOTALMENTE ROSCADO PG DIN 933 CL 8.8 M8 X 10 GALVANIZADO BLANCO
BV267	BV026700	NR	VITE TCEI PG DIN 912 CL 8.8 M 12 X 40	SCREW DIN 912 CL 9.8 M 12 X 40	VIS DIN 912 CL 8.8 M 12 X 40	SCHRAUBE DIN 912 CL 8.8 M 12 X 40	TORNILLO DIN 912 CL 8.8 M 12 X 40
BV268	BV026800	NR	VITE TE PARZIALE FILETTO PG DIN 931 CL 8.8 M 12 X 140 Z.BIANCA	SCREW PARTIAL THREAD DIN 931 PG CL 8.8 M 12 X 140 Z. WHITE	VIS PARTIELLEMENT FILETÉE DIN 931 PG CL 8.8 M 12 X 140 Z. BLANC	TEILGEWINDESCHRAUBE DIN 931 PG CL 8.8 M 12 X 140 Z. WEIß	TORNILLO PARCIALMENTE ROSCADO PG DIN 931 CL 8.8 M 12 X 140 GALVANIZADO BLANCO
BV269	BV026900	NR	VITE TC CROCE PG DIN 7985 CL 4.8 M 6 X 25 Z.BIANCA	SCREW DIN 7985 CL 4.8 M 6 X 25	VIS CROIX DIN 7985 CL 4.8 M 6 X 25 GALVANISATION BLANCHE	SCHRAUBE	TORNILLO
BV270	BV027000	NR	VITE TCEI PG DIN 912 CL 8.8 M 12 X 40	SCREW DIN 912 CL 9.8 M 12 X 40	VIS DIN 912 CL 8.8 M 12 X 40	SCHRAUBE DIN 912 CL 8.8 M 12 X 40	TORNILLO DIN 912 CL 8.8 M 12 X 40
BV271	BV027100	NR	TCEI UNC ASME/ANSI B18.3 ASTM A 574 1/2 X 1"1/4 GEOMET	TCEI UNC ASME/ANSI B18.3 ASTM A 574 1/2 X 1"1/4 GEOMET	TCEI UNC ASME/ANSI B18.3 ASTM A 574 1/2 X 1"1/4 GEOMET	TCEI UNC ASME/ANSI B18.3 ASTM A 574 1/2 X 1"1/4 GEOMET	TCEI UNC ASME/ANSI B18.3 ASTM A 574 1/2 X 1"1/4 GEOMET
BV272	BV027200	NR	TCEI UNC ASME/ANSI B18.3 ASTM A 574 1/4-20 X 1"1/2 GEOMET	TCEI UNC ASME/ANSI B18.3 ASTM A 574 1/4-20 X 1"1/2 GEOMET	TCEI UNC ASME/ANSI B18.3 ASTM A 574 1/4-20 X 1"1/2 GEOMET	TCEI UNC ASME/ANSI B18.3 ASTM A 574 1/4-20 X 1"1/2 GEOMET	TCEI UNC ASME/ANSI B18.3 ASTM A 574 1/4-20 X 1"1/2 GEOMET
BV273	BV027300	NR	VITE TE PARZIALE FILETTO PG DIN 931 CL 8.8 M 12 X 70 Z.BIANCA	SCREW PARTIAL THREAD DIN 931 PG CL 8.8 M 12 X 70 Z. WHITE	VIS PARTIELLEMENT FILETÉE DIN 931 PG CL 8.8 M 12 X 70 Z. BLANC	TEILGEWINDESCHRAUBE DIN 931 PG CL 8.8 M 12 X 70 Z. WEIß	TORNILLO PARCIALMENTE ROSCADO PG DIN 931 CL 8.8 M 12 X 70 GALVANIZADO BLANCO





POS	Codice	U.M.	 Descrizione	 Description	 Designation	 Benennung	 Descripción
BV274	BV027400	NR	VITE TE TUTTO FILETTO PG DIN 933 CL 8.8 M 5 X 20 Z.D.BIANCA	SCREW ALL THREAD DIN 933 PG CL 8.8 M 5 X 20 ZD WHITE	VIS ENTIÈREMENT FILETÉE DIN 933 CL 8.8 M 5 X 20 GALVANISATION BLANCHE	SCHRAUBE	TORNILLO
BV275	BV027500	NR	VITE TSPEI PG DIN 7991 CL 10.9 M 6 X 70 Z.BIANCA	TSPEI PG SCREW DIN 7991 CL 10.9 M 6 X 70 Z. WHITE	VIS DIN 7991 CL 10.9 M 6 X 70 Z. BLANC	TSPEI PG SCHRAUBE DIN 7991 CL 10.9 M 6 X 70 Z. WEIß	TORNILLO TSPEI PG DIN 7991 CL 10.9 M 6 X 70 GALVANIZADO BLANCO
BV276	BV027600	NR	VITE TCEI PG DIN 912 CL 8.8 M 5 X 14 Z.BIANCA	SCREW DIN 912 PG CL 8.8 M 5 X 14 Z. WHITE	VIS DIN 912 CL 8.8 M 5 X 14 GALVANISATION BLANCHE	SCHRAUBE	TORNILLO
BV277	BV027700	NR	VITE TBEI PG ISO 7380 CL 10.9 M 10 X 35 Z.BIANCA	HEX SOCKET SCREW ISO 7380 PG CL 10.9 M 10 X 35 Z. WHITE	VIS ISO 7380 PG CL 10.9 M 10 X 35 Z. BLANC	SCHRAUBE ISO 7380 PG CL 10.9 M 10 X 35 Z. WEIß	TORNILLO TBEI PG ISO 7380 CL 10.9 M 10 X 35 GALVANIZADO BLANCO
BV278	BV027800	NR	VITE TE PARZIALE FILETTO PG DIN 931 CL 10.9 M 16 X 60	SCREW PARTIAL THREAD DIN 931 PG CL 10.9 M 16 X 60	VIS TE PARTIELLEMENT FILETÉE PG DIN 931 CL 10.9 M 16 X 60	TEILGEWINDESCHRAUBE DIN 931 PG CL 10.9 M 16 X 60	TORNILLO PARCIALMENTE ROSCADO PG DIN 931 CL 10.9 M 16 X 60
BV279	BV027900	NR	VITE TE PARZIALE FILETTO PG DIN 931 CL 8.8 M 12 X 60 Z.BIANCA	SCREW PARTIAL THREAD DIN 931 PG CL 8.8 M 12 X 60 Z. WHITE	VIS PARTIELLEMENT FILETÉE DIN 931 PG CL 8.8 M 12 X 60 Z. BLANC	TEILGEWINDESCHRAUBE DIN 931 PG CL 8.8 M 12 X 60 Z. WEIß	TORNILLO PARCIALMENTE ROSCADO PG DIN 931 CL 8.8 M 12 X 60 GALVANIZADO BLANCO
BV280	BV028000	NR	VITE TE PARZIALE FILETTO PG DIN 931 CL 8.8 M 12 X 55 Z.BIANCA	SCREW PARTIAL THREAD DIN 931 PG CL 8.8 M 12 X 55 Z. WHITE	VIS PARTIELLEMENT FILETÉE DIN 931 PG CL 8.8 M 12 X 55 Z. BLANC	TEILGEWINDESCHRAUBE DIN 931 PG CL 8.8 M 12 X 55 Z. WEIß	TORNILLO PARCIALMENTE ROSCADO PG DIN 931 CL 8.8 M 12 X 55 GALVANIZADO BLANCO
BV281	BV028100	NR	VITE TE PARZIALE FILETTO PG DIN 931 CL 8.8 M 14 X 45 Z.BIANCA	SCREW PARTIAL THREAD DIN 931 PG CL 8.8 M 14 X 45 Z. WHITE	VIS PARTIELLEMENT FILETÉE DIN 931 PG CL 8.8 M 14 X 45 Z. BLANC	TEILGEWINDESCHRAUBE DIN 931 PG CL 8.8 M 14 X 45 Z. WEIß	TORNILLO PARCIALMENTE ROSCADO PG DIN 931 CL 8.8 M 14 X 45 GALVANIZADO BLANCO
BV282	BV028200	NR	VITE TE TUTTO FILETTO PG DIN 933 CL 8.8 M 8 X 55 Z.BIANCA	SCREW ALL THREAD DIN 933 PG CL 8.8 M 8 X 55 Z. WHITE	VIS TE ENTIÈREMENT FILETÉE PG DIN 933 CL 8.8 M 8 X 55 Z.BLANC	VOLLGEWINDESCHRAUBE DIN 933 PG CL 8.8 M 8 X 55 Z. WEIß	TORNILLO TOTALMENTE ROSCADO PG DIN 933 CL 8.8 M 8 X 55 GALVANIZADO BLANCO
BV283	BV028300	NR	VITE TCEI INTERAMENTE FILETTATA PG CL 8.8 M 8 X 45 Z.BIANCA	SCREW TCEI FULLY THREADED PG CL 8.8 M 8 X 45 Z. WHITE	VIS	SCHRAUBE	TORNILLO
BV284	BV028400	NR	VITE TCEI PG DIN 912 CL 8.8 M 4 X 35 Z.BIANCA	SCREW TCEI DIN 912 CL 8.8 M 4 X 35 Z. WHITE	VIS	SCHRAUBE	TORNILLO





POS	Codice	U.M.	 Descrizione	 Description	 Designation	 Benennung	 Descripción
BV285	BV028500	NR	VITE TCEI PG DIN 912 CL 8.8 M 4 X 50 Z.BIANCA	SCREW TCEI DIN 912 CL 8.8 M 4 X 50 Z. WHITE	VIS	SCHRAUBE	TORNILLO
BV286	BV028600	NR	VITE TCEI PG DIN 912 CL 8.8 M 5 X 25 Z.BIANCA	SCREW TCEI DIN 912 CL 8.8 M 5 X 25 Z. WHITE	VIS	SCHRAUBE	TORNILLO
BV287	BV028700	NR	VITE TCEI PG DIN 912 CL 8.8 M 5 X 50 GEO 321 A	SCREW TCEI DIN 912 CL 8.8 M 5 X 50 GEO 321 A	VIS	SCHRAUBE	TORNILLO
BV293	BV029300	NR	VITE TCEI PG DIN 912 CL 8.8 M 8 X 90 Z.BIANCA	SCREW TCEI DIN 912 CL 8.8 M 8 X 90 Z. WHITE	VIS	SCHRAUBE	TORNILLO
BV294	BV029400	NR	VITE TCEI PG DIN 912 CL 8.8 M 10 X 16 Z.BIANCA	SCREW TCEI DIN 912 CL 8.8 M 10 X 16 Z. WHITE	VIS	SCHRAUBE	TORNILLO
BV295	BV029500	NR	VITE TCEI PG DIN 912 CL 8.8 M 10 X 20 Z.BIANCA	SCREW TCEI DIN 912 CL 8.8 M 10 X 20 Z. WHITE	VIS	SCHRAUBE	TORNILLO
BV297	BV029700	NR	VITE TCEI PG DIN 912 CL 8.8 M 10 X 40 Z.BIANCA	SCREW TCEI DIN 912 CL 8.8 M 10 X 40 Z. WHITE	VIS	SCHRAUBE	TORNILLO
BV298	BV029800	NR	VITE TCEI PG DIN 912 CL 8.8 M 10 X 65 Z.BIANCA	SCREW TCEI DIN 912 CL 8.8 M 10 X 65 Z. WHITE	VIS	SCHRAUBE	TORNILLO
BV299	BV029900	NR	VITE TCEI PG DIN 912 CL 8.8 M 10 X 120 Z.BIANCA	SCREW TCEI DIN 912 CL 8.8 M 10 X 120 Z. WHITE	VIS	SCHRAUBE	TORNILLO
BV300	BV030000	NR	VITE TCEI PG DIN 912 CL 8.8 M 12 X 30 Z.BIANCA	VITE TCEI PG DIN 912 CL 8.8 M 12 X 30 Z.BIANCA	VIS	SCHRAUBE	TORNILLO
BV301	BV030100	NR	VITE TCEI UNC ASME/ANSI B18.3 ASTM A 574 1/4 X 1"3/4	TCEI SCREW UNC ASME / ANSI B18.3 ASTM A 574 1/4 X 1 "3/4	VIS	SCHRAUBE	TORNILLO
BV303	BV030300	NR	VITE TCEI UNC ASME/ANSI B18.3 ASTM A 574 5/16 X 3/4	TCEI SCREW UNC ASME / ANSI B18.3 ASTM A 574 5/16 X 3/4	VIS	SCHRAUBE	TORNILLO
BV304	BV030400	NR	VITE TCEI PG DIN 912 CL 12.9 M 10 X 75	SCREW TCEI DIN 912 CL 12.9 M 10 X 75	VIS	SCHRAUBE	TORNILLO
BV305	BV030500	NR	VITE TCEI PG DIN 912 CL 12.9 M 14 X 55	SCREW TCEI DIN 912 CL 12.9 M 14 X 55	VIS	SCHRAUBE	TORNILLO
BV306	BV030600	NR	VITE TCEI BASSA PG DIN 7984 CL 10.9 M 12 X 20 Z.D.BIANCA	LOW TCEI SCREW DIN 7984 CL 10.9 M 12 X 20 Z.D. WHITE	VIS	SCHRAUBE	TORNILLO

POS	Codice	U.M.	 Descrizione	 Description	 Designation	 Benennung	 Descripción
BV307	BV030700	NR	VITE TSPEI TUTTO FILETTO PG DIN 7991 CL 10.9 M 12 X 90 ZIC. BIANCO DEID.	TSPEI SCREW FULLY THREADED DIN 7991 CL 10.9 M 12 X 90 ZIC. DEID WHITE.	VIS	SCHRAUBE	TORNILLO
BV308	BV030800	NR	VITE TSPEI TUTTO FIL. PG DIN 7991 CL 10.9 M 14 X 100 ZIC. BIANCO DEID.	TSPEI SCREW ALL THREAD DIN 7991 CL 10.9 M 14 X 100 ZIC. DEID WHITE.	VIS	SCHRAUBE	TORNILLO
BV309	BV030900	NR	VITE TSPEI PG DIN 7991 CL 10.9 M 4 X 25 ZIC. BIANCO DEID.	SCREW TSPEI DIN 7991 CL 10.9 M 4 X 25 ZIC. DEID WHITE.	VIS	SCHRAUBE	TORNILLO
BV310	BV031000	NR	VITE TSPEI PG DIN 7991 CL 10.9 M 5 X 40	SCREW TSPEI DIN 7991 CL 10.9 M 5 X 40	VIS	SCHRAUBE	TORNILLO
BV311	BV031100	NR	VITE TSPEI PG DIN 7991 CL 10.9 M 5 X 80 ZIC. BIANCO DEID.	SCREW TSPEI DIN 7991 CL 10.9 M 5 X 80 ZIC. DEID WHITE.	VIS	SCHRAUBE	TORNILLO
BV312	BV031200	NR	VITE TSPEI PG DIN 7991 CL 10.9 M 8 X 20 ZIC. BIANCO DEID.	SCREW TSPEI DIN 7991 CL 10.9 M 8 X 20 ZIC. DEID WHITE.	VIS	SCHRAUBE	TORNILLO
BV313	BV031300	NR	VITE TSPEI PG DIN 7991 CL 10.9 M 16 X 50 ZIC. BIANCO DEID.	SCREW TSPEI DIN 7991 CL 10.9 M 16 X 50 ZIC. DEID WHITE.	VIS	SCHRAUBE	TORNILLO
BV315	BV031500	NR	VITE TE UNC ANSI B18.2.1 GR.5 5/8 X 3"1/2	SCREW TE UNC ANSI B18.2.1 GR.5 5/8 X 3 1/2 "	VIS	SCHRAUBE	TORNILLO
BV316	BV031600	NR	VITE TE TUTTO FILETTO PG DIN 933 CL 8.8 M 4 X 40 Z.BIANCA	ALL SCREW TE THREAD DIN 933 CL 8.8 M 4 X 40 Z. WHITE	VIS	SCHRAUBE	TORNILLO
BV317	BV031700	NR	VITE TE TUTTO FILETTO PG DIN 933 CL 8.8 M 5 X 55 Z.BIANCA	ALL SCREW TE THREAD DIN 933 CL 8.8 M 5 X 55 Z. WHITE	VIS	SCHRAUBE	TORNILLO
BV318	BV031800	NR	VITE TE TUTTO FILETTO PG DIN 933 CL 8.8 M 6 X 10 Z.BIANCA	ALL SCREW TE THREAD DIN 933 CL 8.8 M 6 X 10 Z. WHITE	VIS	SCHRAUBE	TORNILLO
BV319	BV031900	NR	VITE TE TUTTO FILETTO PG DIN 933 CL 8.8 M 6 X 50 Z.BIANCA	ALL SCREW TE THREAD DIN 933 CL 8.8 M 6 X 50 Z. WHITE	VIS	SCHRAUBE	TORNILLO
BV320	BV032000	NR	VITE TE TUTTO FILETTO PG DIN 933 CL 8.8 M 8 X 45 Z.BIANCA	ALL SCREW TE THREAD DIN 933 CL 8.8 M 8 X 45 Z. WHITE	VIS	SCHRAUBE	TORNILLO

POS	Codice	U.M.	 Descrizione	 Description	 Designation	 Benennung	 Descripción
BV321	BV032100	NR	VITE TE TUTTO FILETTO PG DIN 933 CL 8.8 M 8 X 65 Z.BIANCA	ALL SCREW TE THREAD DIN 933 CL 8.8 M 8 X 65 Z. WHITE	VIS	SCHRAUBE	TORNILLO
BV322	BV032200	NR	VITE TE TUTTO FILETTO PG DIN 933 CL 8.8 M 8 X 80 Z.BIANCA	ALL SCREW TE THREAD DIN 933 CL 8.8 M 8 X 80 Z. WHITE	VIS	SCHRAUBE	TORNILLO
BV323	BV032300	NR	VITE TE TUTTO FILETTO PG DIN 933 CL 8.8 M 10 X 75 Z.BIANCA	ALL SCREW TE THREAD DIN 933 CL 8.8 M 10 X 75 Z. WHITE	VIS	SCHRAUBE	TORNILLO
BV324	BV032400	NR	VITE TE TUTTO FILETTO PG DIN 933 CL 8.8 M 12 X 75 Z.BIANCA	ALL SCREW TE THREAD DIN 933 CL 8.8 M 12 X 75 Z. WHITE	VIS	SCHRAUBE	TORNILLO
BV326	BV032600	NR	VITE TE PARZIALE FILETTO PG DIN 931 CL 8.8 M 8 X 90 Z.BIANCA	SCREW TE PARTIAL THREAD DIN 931 CL 8.8 M 8 X 90 Z. WHITE	VIS	SCHRAUBE	TORNILLO
BV327	BV032700	NR	VITE TE PARZIALE FILETTO PG DIN 931 CL 8.8 M 8 X 100 Z.BIANCA	SCREW TE PARTIAL THREAD DIN 931 CL 8.8 M 8 X 100 Z. WHITE	VIS	SCHRAUBE	TORNILLO
BV329	BV032900	NR	VITE TE PARZIALE FILETTO PG DIN 931 CL 8.8 M 10 X 40 Z.BIANCA	SCREW TE PARTIAL THREAD DIN 931 CL 8.8 M 10 X 40 Z. WHITE	VIS	SCHRAUBE	TORNILLO
BV330	BV033000	NR	VITE TE PARZIALE FILETTO PG DIN 931 CL 8.8 M 10 X 45 Z.BIANCA	SCREW TE PARTIAL THREAD DIN 931 CL 8.8 M 10 X 45 Z. WHITE	VIS	SCHRAUBE	TORNILLO
BV331	BV033100	NR	VITE TE PARZIALE FILETTO PG DIN 931 CL 8.8 M 10 X 60 Z.BIANCA	SCREW TE PARTIAL THREAD DIN 931 CL 8.8 M 10 X 60 Z. WHITE	VIS	SCHRAUBE	TORNILLO
BV332	BV033200	NR	VITE TE PARZIALE FILETTO PG DIN 931 CL 8.8 M 12 X 40 Z.BIANCA	SCREW TE PARTIAL THREAD DIN 931 CL 8.8 M 12 X 40 Z. WHITE	VIS	SCHRAUBE	TORNILLO
BV333	BV033300	NR	VITE TE PARZIALE FILETTO PG DIN 931 CL 8.8 M 12 X 45 Z.BIANCA	SCREW TE PARTIAL THREAD DIN 931 CL 8.8 M 12 X 45 Z. WHITE	VIS	SCHRAUBE	TORNILLO

POS	Codice	U.M.	 Descrizione	 Description	 Designation	 Benennung	 Descripción
BV334	BV033400	NR	VITE TE PARZIALE FILETTO PG DIN 931 CL 8.8 M 12 X 50 Z.BIANCA	SCREW TE PARTIAL THREAD DIN 931 CL 8.8 M 12 X 50 Z. WHITE	VIS	SCHRAUBE	TORNILLO
BV337	BV033700	NR	VITE TE PARZIALE FILETTO PG DIN 931 CL 8.8 M 14 X 60 Z.BIANCA	SCREW TE PARTIAL THREAD DIN 931 CL 8.8 M 14 X 60 Z. WHITE	VIS	SCHRAUBE	TORNILLO
BV338	BV033800	NR	VITE TE PARZIALE FILETTO PG DIN 931 CL 8.8 M 14 X 120 Z.BIANCA	SCREW TE PARTIAL THREAD DIN 931 CL 8.8 M 14 X 120 Z. WHITE	VIS	SCHRAUBE	TORNILLO
BV339	BV033900	NR	VITE TE PARZIALE FILETTO PG DIN 931 CL 8.8 M 16 X 50 Z.BIANCA	SCREW TE PARTIAL THREAD DIN 931 CL 8.8 M 16 X 50 Z. WHITE	VIS	SCHRAUBE	TORNILLO
BV340	BV034000	NR	VITE TE PARZIALE FILETTO PG DIN 931 CL 8.8 M 16 X 65 Z.BIANCA	SCREW TE PARTIAL THREAD DIN 931 CL 8.8 M 16 X 65 Z. WHITE	VIS	SCHRAUBE	TORNILLO
BV341	BV034100	NR	VITE TE TUTTO FILETTO PF DIN 961 CL 8.8 M 8 X 1 X 35 Z.BIANCA	ALL SCREW TE THREAD DIN 961 CL 8.8 M 8 X 1 X 35 Z. WHITE	VIS	SCHRAUBE	TORNILLO
BV342	BV034200	NR	VITE TE TUTTO FILETTO PF DIN 961 CL 8.8 M 20 X 1,5 X 35 Z.BIANCO	ALL SCREW TE THREAD DIN 961 CL 8.8 M 20 X 1.5 X 35 Z. WHITE	VIS	SCHRAUBE	TORNILLO
BV344	BV034400	NR	VITE TE TUTTO FILETTO PG DIN 933 CL 10.9 M 10 X 30 Z.D.BIANCA	ALL SCREW TE THREAD DIN 933 CL 10.9 M 10 X 30 Z.D. WHITE	VIS	SCHRAUBE	TORNILLO
BV346	BV034600	NR	VITE TE TUTTO FILETTO PG DIN 933 CL 10.9 M 16 X 65 GEO 321 A	ALL SCREW TE THREAD DIN 933 CL 10.9 M 16 X 65 GEO 321 A	VIS	SCHRAUBE	TORNILLO
BV347	BV034700	NR	VITE TE PARZIALE FILETTO PG DIN 931 CL 10.9 M 12 X 40 Z.D.BIANCA	SCREW TE PARTIAL THREAD DIN 931 CL 10.9 M 12 X 40 Z.D. WHITE	VIS	SCHRAUBE	TORNILLO
BV348	BV034800	NR	VITE TE PARZIALE FILETTO PG DIN 931 CL 10.9 M 12 X 75 Z.D.BIANCA	SCREW TE PARTIAL THREAD DIN 931 CL 10.9 M 12 X 75 Z.D. WHITE	VIS	SCHRAUBE	TORNILLO

POS	Codice	U.M.	 Descrizione	 Description	 Designation	 Benennung	 Descripción
BV349	BV034900	NR	VITE TE PARZIALE FILETTO PG DIN 931 CL 10.9 M 16 X 45 Z.D.BIANCA	SCREW TE PARTIAL THREAD DIN 931 CL 10.9 M 16 X 45 Z.D. WHITE	VIS	SCHRAUBE	TORNILLO
BV350	BV035000	NR	VITE TE PARZIALE FILETTO PG DIN 931 CL 10.9 M 16 X 75 Z.D.BIANCA	SCREW TE PARTIAL THREAD DIN 931 CL 10.9 M 16 X 75 Z.D. WHITE	VIS	SCHRAUBE	TORNILLO
BV351	BV035100	NR	VITE TE PARZIALE FILETTO PG DIN 931 CL 10.9 M 16 X 180	SCREW TE PARTIAL THREAD DIN 931 CL 10.9 M 16 X 180	VIS	SCHRAUBE	TORNILLO
BV352	BV035200	NR	VITE TE PARZIALE FILETTO PG DIN 931 CL 10.9 M 16 X 230 GEO 321 A	SCREW TE PARTIAL THREAD DIN 931 CL 10.9 M 16 X 230 GEO 321 A	VIS	SCHRAUBE	TORNILLO
BV354	BV035400	NR	VITE TE TUTTO FILETTO PF DIN 961 CL 10.9 M 12 X 1,25 X 35 Z.D.BIANCA	ALL SCREW TE THREAD DIN 961 CL 10.9 M 12 X 1.25 X 35 Z.D. WHITE	VIS	SCHRAUBE	TORNILLO
BV355	BV035500	NR	VITE TC CROCE PG DIN 7985 CL 4.8 M 4 X 10 Z.BIANCA	SCREW TC DIN 7985 CROSS CL 4.8 M 4 X 10 Z. WHITE	VIS	SCHRAUBE	TORNILLO
BV356	BV035600	NR	VITE TC CROCE PG DIN 7985 CL 4.8 M 5 X 22 Z.BIANCA	SCREW TC DIN 7985 CROSS CL 4.8 M 5 X 22 Z. WHITE	VIS	SCHRAUBE	TORNILLO
BV359	BV035900	NR	VITE TE 8.8 ZINCATE M 6 X 65 PARZIALE	SCREW TE 8.8 GALVANIZED M 6 X 65 PARTIAL	VIS	SCHRAUBE	TORNILLO
BV360	BV036000	NR	VITE TE 8.8 ZINCATE M 14 X 65 PARZIALE	SCREW TE 8.8 GALVANIZED M 14 X 65 PARTIAL	VIS	SCHRAUBE	TORNILLO
BV361	BV036100	NR	VITE TBEI PG ISO 7380 CL 10.9 M 5 X 20 Z.BIANCA	HEX SOCKET SCREW ISO 7380 PG CL 10.9 M 5 X 20 Z. WHITE	VIS ISO 7380 CL 10.9 M 5 X 20 GALVANISATION BLANCHE	SCHRAUBE	TORNILLO
BV362	BV036200	NR	VITE TSPEI PG DIN 7991 CL 10.9 M 6 X 35 Z.BIANCA	SCREW DIN 7991 CL 10.9 M 6 X 35 Z. WHITE			
BV363	BV036300	NR	VITE TC CROCE PG DIN 7985 CL 4.8 M 6 X 12 Z.BIANCA	CROSS HEAD SCREW DIN 7985 PG CL 4.8 M 6 X 12 Z. WHITE	VIS DIN 7985 CL 4.8 M 6 X 12 GALVANISATION BLANCHE	SCHRAUBE	TORNILLO
BV364	BV036400	NR	VITE TE PARZIALE FILETTO PG DIN 931 CL 10.9 M 16 X 160	SCREW PARTIAL THREAD DIN 931 PG CL 10.9 M 16 X 160	VIS TE PARTIELLEMENT FILETÉE PG DIN 931 CL 10.9 M 16 X 60	TEILGEWINDESCHRAUBE DIN 931 PG CL 10.9 M 16 X 160	TORNILLO PARCIALMENTE ROSCADO PG DIN 931 CL 10.9 M 16 X 160

POS	Codice	U.M.	 Descrizione	 Description	 Designation	 Benennung	 Descripción
BV365	BV036500	NR	VITE TSPEI PG DIN 7991 CL 10.9 M 10 X 25 Z.BIANCA	TSPEI PG SCREW DIN 7991 CL 10.9 M 10 X 25 Z. WHITE	VIS DIN 7991 CL 10.9 M 10 X 25 GALVANISATION BLANCHE	SCHRAUBE	TORNILLO
BV366	BV036600	NR	VITE TE TUTTO FILETTO PF DIN 961 CL 8.8 M 20 X 1,5 X 35 Z.BIANCO	ALL SCREW TE THREAD DIN 961 CL 8.8 M 20 X 1.5 X 35 Z. WHITE	VIS	SCHRAUBE	TORNILLO
BV367	BV036700	NR	VITE TE PARZIALE FILETTO PG DIN 931 CL 10.9 M 16 X 120	SCREW PARTIAL THREAD DIN 931 PG CL 10.9 M 16 X 120	VIS PARTIELLEMENT FILETÉE DIN 931 CL 10.9 M 16 X 120	SCHRAUBE	TORNILLO
BV368	BV036800	NR	VITE TSPEI PG DIN 7991 CL 10.9 M 8 X 16 Z.BIANCA	SCREW DIN 7991 CL 10.9 M 8 X 16 Z. WHITE	VIS DIN 7991 CL 10.9 M 8 X 16 GALVANISATION BLANCHE		
BV369	BV036900	NR	VITE TE PARZIALE FILETTO PG DIN 931 CL 8.8 M 6 X 90 Z.BIANCA	SCREW THREAD DIN 931 PG CL 8.8 M 6 X 90 Z. WHITE	VIS FILETÉE DIN 931 CL 8.8 M 6 X 90 GALVANISÉE BLANCHE	VOLLGEWINDESCHRAUBE DIN 931 PG CL 8.8 M 6 X 90 Z. WEIß	TORNILLO ROSCADO DIN 931 CL 8.8 M 6 X 90 GALVANIZADO BLANCO
BV370	BV037000	NR	VITE TBEI PG ISO 7380 CL 10.9 M 8 X 30 Z.BIANCA	HEX SOCKET SCREW ISO 7380 PG CL 10.9 M 8 X 30 Z. WHITE	VIS ISO 7380 PG CL 10.9 M 8 X 30 Z. BLANC	TBEI PG SCHRAUBE ISO 7380 CL 10.9 M 8 X 30 Z. WEIß	TORNILLO TBEI PG ISO 7380 CL 10.9 M 8 X 30 GALVANIZADO BLANCO
BV371	BV037100	NR	VITE TE TUTTO FILETTO PG DIN 933 CL 8.8 M 5 X 30 Z.BIANCA	SCREW ALL THREAD DIN 933 PG CL 8.8 M 5 X 30 Z. WHITE	VIS TE ENTIÈREMENT FILETÉE PG DIN 933 CL 8.8 M 5 X 30 Z.BLANC	VOLLGEWINDESCHRAUBE DIN 933 PG CL 8.8 M 5 X 30 Z. WEIß	TORNILLO TOTALMENTE ROSCADO PG DIN 933 CL 8.8 M 5 X 30 GALVANIZADO BLANCO
BV372	BV037200	NR	VITE TE TUTTO FILETTO PG DIN 933 CL 8.8 M 5 X 35 Z.BIANCA	SCREW ALL THREAD DIN 933 PG CL 8.8 M 5 X 35 Z. WHITE	VIS TE ENTIÈREMENT FILETÉE PG DIN 933 CL 8.8 M 5 X 35 Z.BLANC	VOLLGEWINDESCHRAUBE DIN 933 PG CL 8.8 M 5 X 35 Z. WEIß	TORNILLO TOTALMENTE ROSCADO PG DIN 933 CL 8.8 M 5 X 35 GALVANIZADO BLANCO
BV373	BV037300	NR	VITE TSPEI PG DIN 7991 CL 10.9 M 5 X 10 Z.BIANCA	TSPEI PG SCREW DIN 7991 CL 10.9 M 5 X 10 Z. WHITE	VIS DIN 7991 CL 10.9 M 5 X 10 GALVANISATION BLANCHE	SCHRAUBE	TORNILLO
BV374	BV037400	NR	VITE TE TUTTO FILETTO PG DIN 931 CL 8.8 M 20 X 130 Z.BIANCA	SCREW THREAD DIN 931 PG CL 8.8 M 20 X 130	VIS FILETÉE DIN 931 CL 8.8 M 20 X 130	SCHRAUBE	TORNILLO
BV375	BV037500	NR	VITE TSPEI PG DIN 7991 CL 10.9 M 8 X 120 Z.BIANCA	SCREW DIN 7991 CL 10.9 M 8 X 120 Z. WHITE	VIS DIN 7991 CL 10.9 M 8 X 120 GALVANISATION BLANCHE		
BV376	BV037600	NR	VITE TCEI PARZIALE FILETTO PG DIN 912 CL 8.8 M 6 X 65 Z.BIANCA	SCREW DIN 912 M6 X 65 CL 8.8 Z. WHITE	VIS DIN 912 CL 8.8 M 6 X 65 GALVANISATION BLANCHE	SCHRAUBE	TORNILLO



Viteria













Fasteners











POS	Codice	U.M.	Descrizione	Description	Designation	Benennung	Descripción
BV377	BV037700	NR	VITE TCEI PARZIALE FILETTO PG DIN 912 CL 8.8 M 6 X 85 Z.BIANCA	SCREW DIN 912 M6 X 85 CL 8.8 Z. WHITE	VIS DIN 912 CL 8.8 M 6 X 85 GALVANISATION BLANCHE	SCHRAUBE	TORNILLO
BV378	BV037800	NR	VITE TE TUTTO FILETTO PG DIN 933 INOX A2 M 4 X 25	SCREW ALL THREAD DIN 933 PG CL 8.8 M 4 X 25 INOX	VIS ENTièrement FILETÉE DIN 933 CL 8.8 M 4 X 25 INOX	SCHRAUBE	TORNILLO
BV379	BV037900	NR	VITE TBEI PG ISO 7380 CL 10.9 M 5 X 10 Z.BIANCA	HEX SOCKET SCREW ISO 7380 PG CL 10.9 M 5 X 10 Z. WHITE	VIS ISO 7380 CL 10.9 M 5 X 10 GALVANISATION BLANCHE	SCHRAUBE	TORNILLO













POS	Codice	U.M.	 Descrizione	 Description	 Designation	 Benennung	 Descripción
RB1	RB000100	NR	DADO PER OGIVA Ø=12	NUT FOR OGIVA Ø = 12	ÉCROU POUR OGIVE Ø=12	SCHRAUBENMUTTER FÜR OGIVA Ø = 12	TUERCA PARA OJIVA Ø=12
RD1	RD000100	NR	RACCORDO CORPO A "T" EO F(DKOL)-M-M 8L	FITTING BODY A "T" EO F (DKOL) M-M-8L	RACCORD CORP "T" EO F (DKOL) M-M-8L	T-ANSCHLUSSSTÜCK EO F (DKOL) M-M-8L	UNIÓN EN "T" EO F(DKOL)-M-M 8L
RD2	RD000200	NR	RACCORDO CORPO A "T" EO F(DKOL)-M-M 10L	FITTING BODY A "T" EO F (DKOL) M-M-10L	RACCORD EN "T" EO F(DKOL)-M-M 10L	ANSCHLUSS	CONEXION
RD3	RD000300	NR	RACCORDO CORPO A "T" EO F(DKOL)-M-M 12L	FITTING BODY A "T" EO F (DKOL) M-M-12L	RACCORD CORP "T" EO F(DKOL)-M-M 12L	T-ANSCHLUSSSTÜCK EO F (DKOL) M-M-12L	UNIÓN EN "T" EO F(DKOL)-M-M 12L
RD4	RD000400	NR	RACCORDO CORPO A "T" EO F(DKOL)-M-M 15L	FITTING BODY A "T" EO F (DKOL) M-M-15L	RACCORD CORPS EN "T" EO F(DKOL)-M-M 15L	T-ANSCHLUSSSTÜCK EO F (DKOL) M-M-15L	UNIÓN EN "T" EO F(DKOL)-M-M 15L
RD5	RD000500	NR	RACCORDO CORPO A "T" EO M-F(DKOL)-M 10L	FITTING BODY A "T" EO M-F (DKOL) M-10L	RACCORD CORPS EN "T" EO M-F (DKOL) M-10L	T-ANSCHLUSSSTÜCK EO M-F (DKOL) M-10L	UNIÓN EN "T" EO M-F(DKOL)-M 10L
RD6	RD000600	NR	RACCORDO CORPO A "T" EO M-F(DKOL)-M 12L	FITTING BODY A "T" EO M-F (DKOL) M-12L	RACCORD EN "T" EO M-F(DKOL)-M 12L	ANSCHLUSS	CONEXION
RD7	RD000700	NR	RACCORDO CORPO A "T" EO 8L M 14*1.5	FITTING BODY A "T" EO 8L M 14 * 1.5	RACCORD EN "T" EO 8L M 14*1.5	ANSCHLUSS	CONEXION
RD8	RD000800	NR	RACCORDO CORPO A "T" EO 10L M 16*1.5	FITTING BODY A "T" M 10L EO 16 * 1.5	RACCORD EN "T" EO 10L M 16*1.5	ANSCHLUSS	CONEXION
RD9	RD000900	NR	RACCORDO CORPO A "T" EO 28L M 36*2	FITTING BODY A "T" M 28L EO 36 * 2	RACCORD CORPS EN "T" M 28L EO 36 * 2	T-ANSCHLUSSSTÜCK M 28L EO 36 * 2	UNIÓN EN "T" EO 28L M 36*2
RD10	RD001000	NR	RACCORDO CORPO A "T" EO 28L M 36*2	FITTING BODY A "T" EO M-F (DKOL) M-10L	RACCORD CORPS EN "T" EO M-F (DKOL) M-10L	T-ANSCHLUSSSTÜCK EO M-F (DKOL) M-10L	UNIÓN EN "T" EO 28L M 36*2
RD11	RD001100	NR	RACCORDO CORPO A "T" EO M-F(DKOL)-M 10L	FITTING BODY A "T" EO M-F (DKOL) M-10L	RACCORD CORP EN "T" EO 28L M 36*2	T-ANSCHLUSSSTÜCK EO M-F (DKOL) M-10L	CUERPO EN "T" CODO EO M-F(DKOL)-M 10L
RD12	RD001200	NR	ADATTATORE "T" GAS M-FG-M 1/4 1/4 1/4	ADAPTOR	ADAPTATEUR	ADAPTER	ADAPTADOR
RG1	RG000100	NR	RACCORDO CORPO A GOMITO 10L MASCH.-FEMM. DKOL	ELBOW FITTING BODY 10L MASCH.-FEMM. DKOL	RACCORD CORPS À GENOUILLÈRE 10L MASCH.-FEMM. DKOL	WINKELSTÜCK	UNIÓN EN CODO 10L MACHO-HEMBRA DKOL
RG2	RG000200	NR	RACCORDO CORPO A GOMITO 12L MASCH.-FEMM. DKOL	ELBOW FITTING BODY 12L MASCH.-FEMM. DKOL	RACCORD COUDÉ 12L MÂLE-FEMELLE DKOL	ANSCHLUSS	CONEXION





POS	Codice	U.M.	 Descrizione	 Description	 Designation	 Benennung	 Descripción
RG3	RG000300	NR	RACCORDO CORPO A GOMITO 20S MASCHIO-FEMMINA DKOS	20S BODY FITTING ELBOW MALE-FEMALE DKOS	RACCORD À GENOUILLE 20S MÂLE-FEMELLE DKOS	WINKELSTÜCK 20S STIFT- BUCHSE DKOS	UNIÓN EN CODO 20S MACHO- HEMBRA DKOS
RG4	RG000400	NR	RACCORDO CORPO A GOMITO 28L MASCHIO-FEMMINA DKOL	28L BODY FITTING ELBOW MALE-FEMALE DKOL	RACCORD CORPS À GENOUILLE MÂLE-FEMELLE DKOL	WINKELSTÜCK 28L STIFT- BUCHSE DKOL	UNIÓN EN CODO 28L MACHO- HEMBRA DKOL
RG5	RG000500	NR	RACCORDO A L MASCHIO- FEMMINA 1/8	BODY 90 ° M / F 1/8 "			
RG6	RG000600	NR	ADATTATORE 90° BSPP M-FG 1/4	ADAPTOR	ADAPTATEUR	ADAPTER	ADAPTADOR
RN1	RN000100	NR	RACCORDO CORPO D'ESTREMITA' TENUTA ED 8L * 3/8 GAS *K*	END FITTING WITH SEAL ED 8L * 3/8 GAS * K *	RACCORD CORPS D'EXTRÉMITÉ AVEC JOINT ED 8L * 3/8 GAS *K*	ANSCHLUSSSTÜCK MIT DICHTUNG ED 8L * 3/8 GAS * K *	UNIÓN CON JUNTA ED 8L * 3/8 GAS *K*
RN2	RN000200	NR	RACCORDO CORPO D'ESTREMITA' TENUTA ED 12L * 3/8 GAS *K*	END FITTING WITH SEAL ED 12L * 3/8 GAS * K *	RACCORD CORPS D'EXTRÉMITÉ AVEC JOINT ED12L * 3/8 GAS *K*	ANSCHLUSSSTÜCK MIT DICHTUNG ED 12L * 3/8 GAS * K *	UNIÓN CON JUNTA ED 12L * 3/8 GAS *K*
RN3	RN000300	NR	RACCORDO CORPO D'ESTREMITA' TENUTA ED 10L * 3/8 GAS *K*	FITTING END OF BODY 'AND SEAL 10L * 3/8 GAS * K *	RACCORD D'EXTRÉMITÉ AVEC JOINT D'ÉTANCHÉITÉ 10L * 3/8 GAS *K*	ANSCHLUSS	CONEXION
RN4	RN000400	NR	RACCORDO CORPO D'ESTREMITA' TENUTA ED 8L * 1/4 GAS *K*	END FITTING WITH SEAL ED 8L * 1/4 GAS * K *	RACCORD CORPS D'EXTRÉMITÉ AVEC JOINT ED 8L * 1/4 GAS *K*	ANSCHLUSSSTÜCK MIT DICHTUNG ED 8L * 1/4 GAS * K *	UNIÓN CON JUNTA ED 8L * 1/4 GAS *K*
RN5	RN000500	NR	RACCORDO CORPO D'ESTREMITA' TENUTA ED 10L * 1/4 GAS *K*	FITTING END OF BODY 'AND SEAL 10L * 1/4 GAS * K *	RACCORD D'EXTRÉMITÉ AVEC JOINT D'ÉTANCHÉITÉ 10L * 1/4 GAS *K*	ANSCHLUSS	CONEXION
RN6	RN000600	NR	RACCORDO CORPO D'ESTREMITA' TENUTA ED 12L * 1/4 GAS	FITTING END OF BODY 'AND SEAL 12L * 1/4 GAS	RACCORD	ANSCHLUSS	CONEXION
RN7	RN000700	NR	RACCORDO NIPLES GAS CON.- GAS CON. 1/4" * 1/4"	FITTING	RACCORD	ANSCHLUSS	RACORD
RN8	RN000800	NR	RACCORDO CORPO D'ESTREMITA' TENUTA ED 15L * 1/2 GAS *K*	END FITTING WITH SEAL ED 15L * 1/2 * K * GAS	RACCORD CORPS D'EXTRÉMITÉ AVEC JOINT ED 15L * 1/2 GAS *K*	ANSCHLUSSSTÜCK MIT DICHTUNG ED 15L * 1/2 GAS *K*	UNIÓN CON JUNTA ED 15L * 1/2 GAS *K*

POS	Codice	U.M.	 Descrizione	 Description	 Designation	 Benennung	 Descripción
RN9	RN000900	NR	RACCORDO CORPO D'ESTREMITA' TENUTA ED 10L * 1/2 GAS *K*	FITTING END OF BODY 'AND SEAL 10L * 1/2 * K * GAS	RACCORD	ANSCHLUSS	CONEXION
RN10	RN001000	NR	RACCORDO CORPO D'ESTREMITA' TENUTA ED 15L * 3/4 GAS *K*	END FITTING WITH SEAL ED 15L * 3/4 GAS * K *	RACCORD CORPS D'EXTRÉMITÉ AVEC JOINT ED 15L * 3/4 GAS * K *	ANSCHLUSSSTÜCK MIT DICHTUNG ED 15L * 3/4 GAS *K*	UNIÓN CON JUNTA ED 15L * 3/4 GAS *K*
RN11	RN001100	NR	RACCORDO CORPO D'ESTREMITA' TENUTA ED 12L * 1/2 GAS *K*	END FITTING WITH SEAL ED 12L * 1/2 GAS * K *	RACCORD CORPS D'EXTRÉMITÉ AVEC JOINT ED 12L * 1/2 GAS *K*	ANSCHLUSSSTÜCK MIT DICHTUNG ED 12L * 1/2 GAS *K*	UNIÓN CON JUNTA ED 12L * 1/2 GAS *K*
RN12	RN001200	NR	RACCORDO CORPO D'ESTR. TENUTA ED 8L * 1/2 GAS	END FITTING WITH SEAL ED 8L * 1/2 GAS	RACCORD CORP D'EXTRÉMITÉ AVEC JOINT ED 8L * 1/2 GAS	ANSCHLUSSSTÜCK MIT DICHTUNG ED 8L * 1/2 GAS	UNIÓN CON JUNTA ED 8L * 1/2 GAS
RN13	RN001300	NR	RACCORDO CORPO D'ESTR. TENUTA ED 8L * 3/4 GAS	CONNECTOR BODY OF EXTR. SEAL AND 8L * 3/4 GAS	RACCORD	ANSCHLUSS	CONEXION
RN14	RN001400	NR	RACCORDO CORPO D'ESTR. TENUTA ED 12L * 3/4 GAS	CONNECTOR BODY OF EXTR. SEAL AND 12L * 3/4 GAS	RACCORD	ANSCHLUSS	CONEXION
RN15	RN001500	NR	RACCORDO CORPO D'ESTR.TENUTA ED 15L * 3/8 GAS	END FITTING WITH SEAL ED 15L * 3/8 GAS	RACCORD CORPS D'EXTRÉMITÉ AVEC JOINT ED15L * 3/8 GAS	ANSCHLUSSSTÜCK MIT DICHTUNG ED 15L * 3/8 GAS	UNIÓN CON JUNTA ED 15L * 3/8 GAS
RN16	RN001600	NR	RACCORDO CORPO D'ESTR.TENUTA ED 22L * 3/4 GAS	END FITTING WITH SEAL ED 22L * 3/4 GAS	RACCORD CORP D'EXTRÉMITÉ AVEC JOINT ED 22L * 3/4 GAS	ANSCHLUSSSTÜCK MIT DICHTUNG ED 22L * 3/4 GAS	UNIÓN CON JUNTA ED 22L * 3/4 GAS
RN17	RN001700	NR	RACCORDO CORPO D'ESTR. TENUTA ED 28L * 3/4" GAS	END FITTING WITH SEAL ED 28L * 3/4 BSP	RACCORD CORPS D'EXTRÉMITÉ AVEC JOINT ED 28L * 3/4 BSP	ANSCHLUSSSTÜCK MIT DICHTUNG ED 28L * 3/4" GAS	UNIÓN CON JUNTA ED 28L * 3/4" GAS
RN18	RN001800	NR	RACCORDO CORPO D'ESTR. TENUTA ED 20S * 3/4 GAS	CONNECTOR BODY OF EXTR. SEAL AND 20S * 3/4 GAS	RACCORD	ANSCHLUSS	CONEXION
RN19	RN001900	NR	RACCORDO CORPO D'ESTREMITA' 8L * M 12X1.5 ED	END FITTING 8L * M 12X1.5 ED	RACCORD CORPS D'EXTRÉMITÉ 8L * M 12X1.5 ED	ANSCHLUSSSTÜCK 8L * M 12X1.5 ED	UNIÓN 8L * M 12X1.5 ED
RN20	RN002000	NR	RACCORDO CORPO D'ESTREMITA' 8L * M 14X1.5 ED	FITTING END OF BODY 'AND 8L * M 14X1.5	RACCORD	ANSCHLUSS	CONEXION

POS	Codice	U.M.	 Descrizione	 Description	 Designation	 Benennung	 Descripción
RN21	RN002100	NR	RACCORDO CORPO D'ESTREMITA' 10L * M 18X1.5 ED	END FITTING 10L * M 18X1.5	RACCORD CORPS D'EXTRÉMITÉ 10L * M 18X1.5 ED	ANSCHLUSSSTÜCK 10L * M 18X1.5 ED	UNIÓN 10L * M 18X1.5 ED
RN22	RN002200	NR	RACCORDO CORPO D'ESTR. TENUTA ED 15L * M 18X1.5	CONNECTOR BODY OF EXTR. SEAL AND 15L * M 18X1.5	RACCORD	ANSCHLUSS	CONEXION
RN23	RN002300	NR	RACCORDO CORPO D'ESTR. TENUTA ED 15L * M 22X1.5	END FITTING WIHT SEAL ED 15L * M 22X1.5	RACCORD CORPS D'EXTRÉMITÉ AVEC JOINT ED 15L * M 22X1.5	ANSCHLUSSSTÜCK MIT DICHTUNG ED 15L * M 22X1.5	UNIÓN CON JUNTA ED 15L * M 22X1.5
RN24	RN002400	NR	RACCORDO CORPO D'ESTR. TENUTA ED 22L * M26X1.5	CONNECTOR BODY OF EXTR. SEAL AND 22L * M26X1.5	RACCORD	ANSCHLUSS	CONEXION
RN25	RN002500	NR	RACCORDO CORPO D'ESTR. TENUTA ED 20S * M27X2	CONNECTOR BODY OF EXTR. SEAL AND 20S * M27X2	RACCORD	ANSCHLUSS	CONEXION
RN26	RN002600	NR	RACCORDO CORPO D'ESTR. 8L * 9/16-18 UNF-2A	END FITTING 8L * 9/16-18 UNF-2A	RACCORD CORPS D'EXTRÉMITÉ 8L * 9/16-18 UNF-2A	ANSCHLUSSSTÜCK 8L * 9/16-18 UNF-2A	UNIÓN 8L * 9/16-18 UNF-2A
RN27	RN002700	NR	RACCORDO CORPO D'ESTR. 12L * 3/4 -16 UNF-2A	END FITTING 12L * 3/4 -16 UNF-2A	RACCORD CORPS D'EXTRÉMITÉ 12L * 3/4 -16 UNF-2A	ANSCHLUSSSTÜCK 12L * 3/4 -16 UNF-2A	UNIÓN 12L * 3/4 -16 UNF-2A
RN28	RN002800	NR	RACCORDO CORPO D'ESTR. 20S * 1.5/16 -12 UN-2A	END FITTING 20S * 1.5/16 -12 UN-2A	RACCORD CORPS D'EXTRÉMITÉ 20S * 1.5/16 -12 UN-2A	ANSCHLUSSSTÜCK 20S * 1.5/16 -12 UN-2A	UNIÓN 20S * 1.5/16 -12 UN-2A
RN29	RN002900	NR	RACCORDO CORPO D'ESTR. TENUTA ED 22L * M26X1.5	END FITTING WITH SEAL ED 22L * M26X1.5	RACCORD CORPS D'EXTRÉMITÉ AVEC JOINT ED 22L * M26X1.5	ANSCHLUSSSTÜCK MIT DICHTUNG ED 22L * M26X1.5	UNIÓN CON JUNTA 22L * M26X1.5
RN30	RN003000	NR	RACCORDO CORPO D'ESTR. TENUTA ED 22L * M26X1.5	END FITTING WITH SEAL ED 22L * M26X1.5	RACCORD CORPS D'EXTRÉMITÉ AVEC JOINT ED 22L * M26X1.5	ANSCHLUSSSTÜCK MIT DICHTUNG ED 22L * M26X1.5	UNIÓN CON JUNTA ED 22L * M26X1.5
RN31	RN003100	NR	RACCORDO CORPO D'ESTREMITA' TENUTA ED 6L * 1/4 GAS *K*	END FITTING WITH SEAL 1/4 BSPP 6L	RACCORD CORPS D'EXTRÉMITÉ AVEC JOINT 1/4 BSPP 6L	ANSCHLUSSSTÜCK MIT DICHTUNG 1/4 BSPP 6L	UNIÓN CON JUNTA 1/4 BSPP 6L
RN32	RN003200	NR	RACCORDO CORPO D'ESTREMITA' TENUTA ED 8L * 3/8 GAS *K*	END FITTING WITH SEAL ED 8L * 3/8 GAS * K *	RACCORD CORPS D'EXTRÉMITÉ AVEC JOINT ED 8L * 3/8 GAS *K*	ANSCHLUSSSTÜCK MIT DICHTUNG ED 8L * 3/8 GAS * K *	UNIÓN CON JUNTA ED 8L * 3/8 GAS *K*

POS	Codice	U.M.	 Descrizione	 Description	 Designation	 Benennung	 Descripción
RN33	RN003300	NR	NIPPLES 1/8" JIS 1/8"GAS	CAP	CAPUCHON	NIPPEL	CAPUCHO
RN34	RN003400	NR	NIPPLES 1/4" JIS 1/4"GAS	CAP	CAPUCHON	NIPPEL	CAPUCHO
RN35	RN003500	NR	NIPPLES 3/8" JIS 1/4"GAS	CAP	CAPUCHON	NIPPEL	CAPUCHO
RN36	RN003600	NR	NIPPLES 3/8" JIS 1/4"GAS	CAP	CAPUCHON	NIPPEL	CAPUCHO
RO1	RO000100	NR	OGIVA PER TUBO Ø=12	OGIVE FOR TUBE Ø = 12	OGIVE POUR TUYAU Ø = 12	OGIVE FÜR ROHR Ø = 12	OJIVA PARA TUBO Ø=12
RR1	RR000100	NR	RONDELLA RAME 1/4	COPPER WASHER 1/4	RONDELLE	SCHEIBE	ARANDELA
RR2	RR000200	NR	RONDELLA BONDED GAS 3/8" *K*	BONDED WASHER GAS 3/8 " * K *	RONDELLE	SCHEIBE	ARANDELA
RR3	RR000300	NR	RONDELLA BONDED METRICA 12 *K*	METRIC BONDED WASHER 12 * K *	RONDELLE BONDED MÉTRIQUE 12 *K*	BONDED UNTERLEGSCHIEBE 12 * K *	ARANDELA BONDED MÉTRICA 12 *K*
RR4	RR000400	NR	RONDELLA BONDED GAS 1/4" *K*	BONDED WASHER GAS 1/4 " * K *	RONDELLE		
RR5	RR000500	NR	RONDELLA BONDED GAS 1/2" *K*	BONDED WASHER GAS 1/2 " * K *	RONDELLE BONDED GAS 1/2" *K*	BONDED UNTERLEGSCHIEBE GAS 1/2" *K*	ARANDELA BONDED GAS 1/2" *K*
RR6	RR000600	NR	RONDELLA RAME 3/8	COPPER WASHER 3/8	RONDELLE	SCHEIBE	ARANDELA
RR7	RR000700	NR	RONDELLA BONDED GAS 1/8" *K*	BONDED WASHER GAS 1/8 " * K *	RONDELLE	SCHEIBE	ARANDELA
RR8	RR000800	NR	RONDELLA BONDED GAS 1" *K*	BONDED WASHER GAS 1 " * K *	RONDELLE BONDED GAS 1" *K*	BONDED UNTERLEGSCHIEBE GAS 1" *K*	ARANDELA BONDED GAS 1" *K*
RR9	RR000900	NR	RONDELLA BONDED GAS 3/4" *K*	BONDED WASHER GAS 3/4 " * K *	RONDELLE BONDED GAS 3/4" *K*	BONDED UNTERLEGSCHIEBE GAS 3/4" *K*	ARANDELA BONDED GAS 3/4" *K*
RR10	RR001000	NR	RONDELLA BONDED GAS 1.1/4"	BONDED WASHER GAS 1.1 / 4 "	RONDELLE	SCHEIBE	ARANDELA
RR11	RR001100	NR	RONDELLA RAME M10	COPPER WASHER M10	RONDELLE	SCHEIBE	ARANDELA
RR12	RR001200	NR	RONDELLA RAME 1/2	COPPER WASHER 1/2	RONDELLE	SCHEIBE	ARANDELA
RR13	RR001300	NR	RONDELLA BONDED M12	BONDED WASHER M12	RONDELLE	SCHEIBE	ARANDELA
RS1	RS000100	NR	COPPIA SEMIFLANGE SAE 6000 3/4"	PAIR 6000 SAE FLANGE HALVES 3/4 "	COUPLE SEMI-BRIDES SAE 6000 3/4"	SAE-HALBFLANSCHEN PAAR 6000 3/4"	PAREJA SEMIBRIDAS SAE 6000 3/4"

POS	Codice	U.M.	 Descrizione	 Description	 Designation	 Benennung	 Descripción
RS2	RS000200	NR	RACC.M 20S(M30X2) - ED M 1"5/16 UNF H=33	FITTING M 20S (M30X2) - ED M 1 "5/16 UNF H = 33	RACCORD M 20S(M30X2) - ED M 1"5/16 UNF H=33	ANSCHLUSSSTÜCK M 20S (M30X2) - ED M 1 "5/16 UNF H = 33	UNIÓN M 20S(M30X2) - ED M 1"5/16 UNF H=33
RS3	RS000300	NR	RIDUZIONE M-F GAS 1" * 1/2"	REDUCING GAS M-F 1 " * 1/2"	RÉDUCTION M-F GAS 1" * 1/2"	REDUKTION M-F GAS 1" * 1/2"	REDUCCIÓN M-F GAS 1" * 1/2"
RS4	RS000400	NR	RACCORDO COLONNETTA M15L - 3/8" GAS H=50	COLUMN CONNECTION M15L - 3/8 "GAS H = 50	RACCORD DOIGT M15L - 3/8 "GAS H = 50	ANSCHLUSS M15L - 3/8 "GAS H = 50	CODO M15L - 3/8" GAS H=50
RS5	RS000500	NR	RACCORDO COLONNETTA M15L - 3/8" GAS H=96	COLUMN CONNECTION M15L - 3/8 "GAS H = 96	RACCORD DOIGT M15L - 3/8" GAS H=96	ANSCHLUSS - 3/8 "GAS H = 96	CODO M15L - 3/8" GAS H=96
RS6	RS000600	NR	CODOLO M1/4" ED X FG 8L (M14X1.5)	FITTING M1 / 4 "X AND FG 8L (M14X1.5)	EMBOUT M1/4" ED X FG 8L (M14X1.5)	SCHAFT M1/4" ED X FG 8L (M14X1.5)	CODO M1/4" ED X FG 8L (M14X1.5)
RS7	RS000700	NR	RIDUZIONE M-F GAS 1" * 1/2"	REDUCING GAS M-F 1 " * 1/2"	RÉDUCTION M-F GAS 1" * 1/2"	REDUZIERUNG GAS M-F 1" * 1/2"	REDUCCIÓN M-F GAS 1" * 1/2"
RS8	RS000800	NR	RACCORDO CODOLO D' ESTR. FEM. DKO 12L*3/8 GAS ED	END FITTING FEM. DKO 12L*3/8 GAS ED	RACCORD FEM. DKO 12L*3/8 GAS ED	ANSCHLUSS FEM. DKO 12L*3/8 GAS ED	CONECTOR FEM. DKO 12L*3/8 GAS ED
RS9	RS000900	NR	MANICOTTO ARIA 1/8-1/8	AIR MANIFOLD 1/8-1/8			
RS10	RS001000	NR	RIDUZIONE M-F GAS 3/8" JIS 1/8" BSPP	REDUCING GAS M-F 3/8" JIS 1/8" BSPP	RÉDUCTION M-F GAS 3/8" JIS 1/8" BSPP	REDUZIERUNG GAS M-F 3/8" JIS 1/8" BSPP	REDUCCIÓN M-F GAS 3/8" JIS 1/8" BSPP
RS11	RS001100	NR	RACCORDO M-M 15L	FITTING M-M 15L			
RS12	RS001200	NR	RACCORDO NIPLES GAS CON.- GAS CON.1/2"1/2"	FITTING 1/2" - 1/2"	RACCORD	ANSCHLUSS	RACORD
RT1	RT000100	NR	TAPPO MASCHIO TE GAS 3/8" SVASATO 60° *K*	SCREW EYE FOR GAS 1/2 "H = 50	BOUCHON	VERSCHLUSS	TAPA
RT2	RT000200	NR	TAPPO MASCHIO ESAGONO INTERNO GAS 1/4" SVASATO 60° *K*	MALE PLUG GAS INTERNAL HEX 1/4 "FLARE 60 ° * K *	BOUCHON MÂLE HEXAGONAL INTÉRIEUR GAS 1/4" ÉVASÉ 60° *K*	ZYLINDRISCHER STOPFEN	TAPÓN MACHO HEXÁGONO INTERNO GAS 1/4" SVASATO 60° *K*
RT3	RT000300	NR	TAPPO MASCHIO TE GAS 1/2" SVASATO 60° *K*	MALE PLUG TE GAS 1/2 "FLARE 60 ° * K *	BOUCHON MÂLE TE GAS 1/2" ÉVASÉ 60° *K*	STECKER TE GAS 1/2 "GESENKT 60 ° * K *	TAPÓN MACHO TE GAS 1/2" ABOCINADO 60° *K*
RT4	RT000400	NR	TAPPO MASCHIO TE GAS 1/4" SVASATO 60° *K*	MALE PLUG TE GAS 1/4 "FLARE 60 ° * K *	BOUCHON	VERSCHLUSS	TAPA
RT5	RT000500	NR	TAPPO MASCHIO ESAGONO INTERNO GAS 3/8" SVASATO 60° *K*	MALE PLUG GAS INTERNAL HEX 3/8 "FLARE 60 ° * K *	BOUCHON	VERSCHLUSS	TAPA

POS	Codice	U.M.	 Descrizione	 Description	 Designation	 Benennung	 Descripción
RT6	RT000600	NR	TAPPO MASCHIO ESAGONO INTERNO GAS 1" SVASATO 60° *K*	MALE PLUG GAS INTERNAL HEX 1 "FLARE 60 ° * K *	BOUCHON MÂLE HEXAGONAL INTÉRIEUR GAS 1" ÉVASÉ 60° *K*	ZYLINDRISCHER STOPFEN + DICHTUNG	TAPÓN MACHO HEXÁGONO INTERNO GAS 1" ABOCINADO 60° *K*
RT7	RT000700	NR	TAPPO MASCHIO TE GAS 1/8" SVASATO 60° *K*	MALE PLUG TE GAS 1/8 "FLARE 60 ° * K *	BOUCHON	VERSCHLUSS	TAPA
RT8	RT000800	NR	TAPPO MASCHIO TE GAS 1/4" JIS	MALE PLUG TE GAS 1/4 " JIS	BOUCHON	VERSCHLUSS	TAPA
RT9	RT000900	NR	TAPPOO FEMMINA COMPLETO 6L	COMPLETE 6L FEMALE CAP			
RT10	RT001000	NR	TAPPOO FEMMINA COMPLETO 8L	COMPLETE 8L FEMALE CAP	COUVERCLE	DECKEL	TAPA
RT11	RT001100	NR	TAPPO CILINDRICO TCEI+GUARNIZIONE GAS CI 5.8 3/4 Z.BIANCA	CYLINDRICAL SOCKET HEAD CAP + SEAL GAS CI 5.8 3/4 Z. WHITE	BOUCHON	VERSCHLUSS	TAPA
RT12	RT001200	NR	TAPPO CILINDRICO TCEI+GUARNIZIONE GAS CI 5.8 1/2 Z.BIANCA	CYLINDRICAL SOCKET HEAD CAP + SEAL GAS CI 5.8 1/2 Z. WHITE	BOUCHON	VERSCHLUSS	TAPA
RV1	RV000100	NR	VITE PER OCCHIO GAS 1/4" H=29 *K*	SCREW EYE FOR GAS 1/4 "H = 29 * K *	VIS	SCHRAUBE	TORNILLO
RV2	RV000200	NR	VITE PER OCCHIO DOPPIA GAS 3/8"	SCREW EYE DOUBLE FOR GAS 3/8 "	VIS	SCHRAUBE	TORNILLO
RV3	RV000300	NR	VITE PER OCCHIO GAS 1/2" H=50	SCREW EYE FOR GAS 1/2 "H = 50	VIS	SCHRAUBE	TORNILLO
RV4	RV000400	NR	VITE PER OCCHIO DOPPIA GAS 1/4"	DOUBLE EYE SCREW FOR GAS 1/4"	VIS DOUBLE À OEIL GAS 1/4"	DOPPEL-AUGENSCHRAUBE GAS 1/4"	TORNILLO DOBLE OJO GAS 1/4"
RV5	RV000500	NR	VITE PER OCCHIO GAS 3/8"	SCREW EYE FOR GAS 3/8"	VIS	SCHRAUBE	TORNILLO
RV6	RV000600	NR	VITE PER OCCHIO GAS 1/8"	SCREW EYE FOR GAS 1/8"	VIS	SCHRAUBE	TORNILLO

