



An Oshkosh Corporation Company

Illustrated Parts Manual

Compact Crawler

X20JA/1, X20JA/2, X20JA/3

X20JP/1, X20JP/2, X20JP/3



X600AJ/1, X600AJ/2, X600AJ/3



Prior to C170003921







31217110

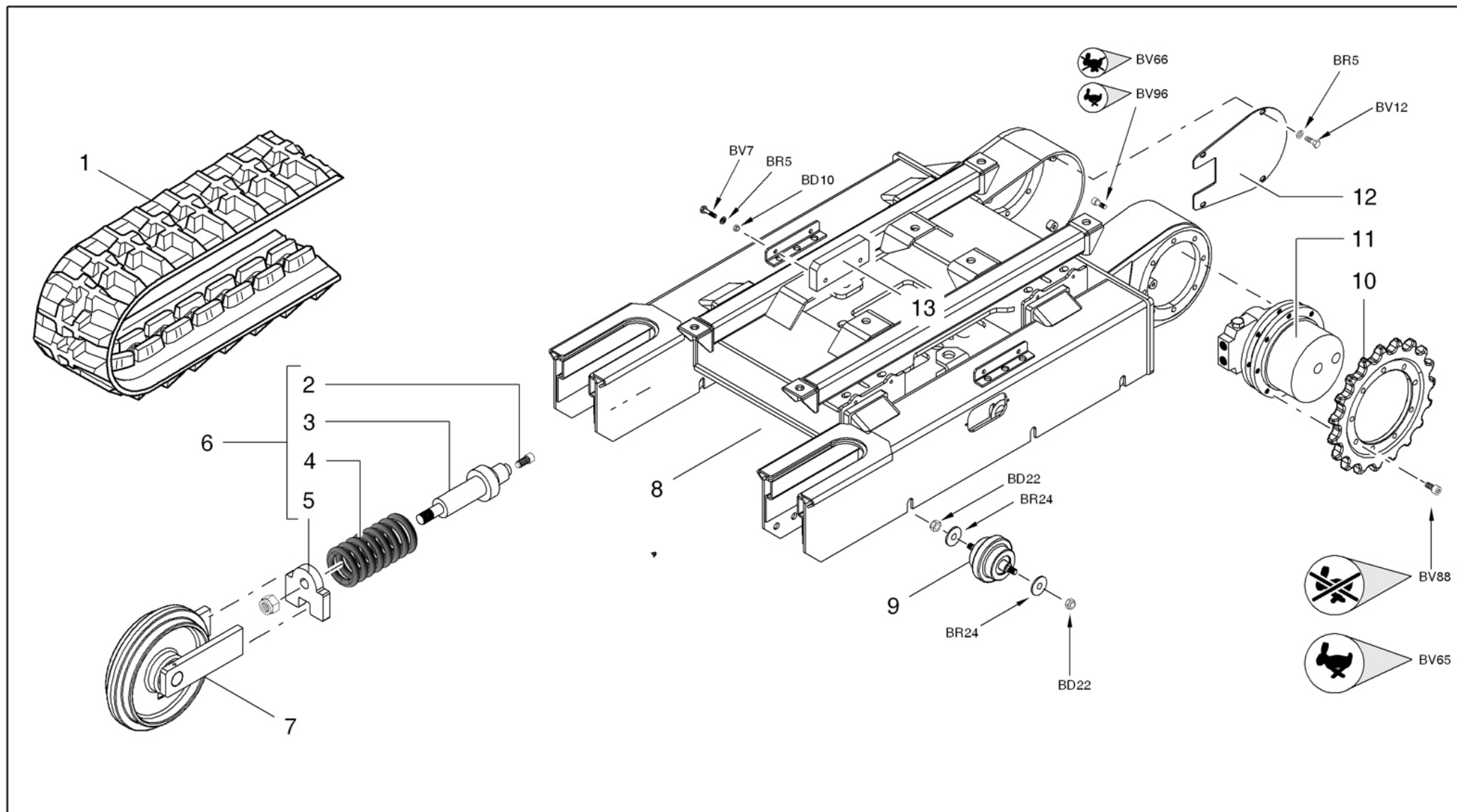

May 1 2024- Rev I



-  SOTTOCARRO CINGOLATO
-  TRACKED UNDERCARRIAGE
-  CHENILLARD

RAUPENFAHRWERK 
 CARRO DE ORUGAS 









Main color codes:  **J1** - JLG Cream,  **J2** - JLG Orange,  **C4** - Green



 SOTTOCARRO CINGOLATO
 TRACKED UNDERCARRIAGE
 CHENILLARD





 RAUPENFAHRWERK
 CARRO DE ORUGAS



POS	Codice	 Descrizione	 Description	 Designation	 Benennung	 Descripción
1	257215L0	CINGOLO IN GOMMA BASSO PROFILO PT10	RUBBER TRACK LOW PROFILE PT10	RUBBER TRACK LOW PROFILE PT10	GUMMIKETTE LOW PROFILE PT10	CAUCHO PISTA DE BAJO PERFIL PT10
1	257215LB	CINGOLO IN GOMMA BASSO PROFILO ANTITRACCIA PT10	RUBBER TRACK LOW PROFILE NO MARKING PT10	RUBBER TRACK LOW PROFILE ANTI-PT10	GUMMIKETTE LOW PROFILE ANTI-PT10	CAUCHO PISTA DE BAJO PERFIL ANTI-PT10
2	03149200	VALVOLA IDRAULICA	HYDRAULIC VALVE	VALVE HYDRAULIQUE	HYDRAULIKVENTIL	VÁLVULA HIDRÁULICA
3	10681670	CILINDRO	CYLINDER	VÉRIN	ZYLINDER	CILINDRO
4	03024801	MOLLA	SPRING	RESSORT	FEDER	MUELLE
5	04635800	PIASTRA	PLATE	PLATINE	PLATTE	PLACA
6	147306Y1	SUPPORTO TENDICINGOLO	IDLER SUPPORT	SUPPORT TENDEUR CHENILLE	KETTENSANNHALTE RUNG	SOPORTE TENSOR ORUGA
7	147309A3	RUOTA TENDICINGOLO	IDLER WHEEL	ROUE TENDEUR DE CHENILLE	RAUPENSPANNRAD	RUEDA TENSOR ORUGA
7	147309H2	RUOTA TENDICINGOLO	IDLER WHEEL	ROUE TENDEUR DE CHENILLE	RAUPENSPANNRAD	RUEDA TENSOR ORUGA
8	172491A3	SOTTOCARRO CINGOLATO	TRACKED UNDERCARRIAGE	CHENILLARD	RAUPENFAHRWERK	CARRO CON ORUGAS
8	172491H2	SOTTOCARRO CINGOLATO	TRACKED UNDERCARRIAGE	CHENILLARD	RAUPENFAHRWERK	CARRO CON ORUGAS
9	147310A3	RULLO INFERIORE	CARRIER ROLLER	ROULEAU INFÉRIEUR	TRAGROLLE	RODILLO INFERIOR
9	147310H2	RULLO INFERIORE	CARRIER ROLLER	ROULEAU INFÉRIEUR	TRAGROLLE	RODILLO INFERIOR
10	257225A3	RUOTA MOTRICE	DRIVE WHEEL	ROUE MOTRICE	ANTRIEBSRAD	WHEEL DRIVE
10	257225H2	RUOTA MOTRICE	DRIVE WHEEL	ROUE D'ENTRAINEMENT	ANTRIEBSRAD	RUEDAS
11	252182H2	MOTORIDUTTORE	GEAR MOTOR	MOTORÉDUCTEUR	GETRIEBEMOTOR	MOTORREDUCTOR
11	273305A3	MOTORIDUTTORE	GEAR MOTOR	MOTORÉDUCTEUR	GETRIEBEMOTOR	MOTORREDUCTOR
11	273305H2	MOTORIDUTTORE	GEAR MOTOR	MOTORÉDUCTEUR	GETRIEBEMOTOR	MOTORREDUCTOR
12	073135A3	COPERCHIO MOTORI CARRO	COVER TRUCK MOTORS	COUVERTURE MOTEURS DE CAMION	COVER LKW-MOTOREN	CUBRIR LOS MOTORES DE CAMIONES
12	073135H2	COPERCHIO MOTORI CARRO	COVER TRUCK MOTORS	COUVERTURE MOTEURS DE CAMION	COVER LKW-MOTOREN	CUBRIR LOS MOTORES DE CAMIONES



Main color codes:  J1 - JLG Cream,  J2 - JLG Orange,  C4 - Green

 SOTTOCARRO CINGOLATO
 TRACKED UNDERCARRIAGE
 CHENILLARD



RAUPENFAHRWERK 
 CARRO DE ORUGAS 

POS	Codice	 Descrizione	 Description	 Designation	 Benennung	 Descripción
13	07313400	PATTINO GUIDACINGOLO SUPERIORE	PAD GUIDE TRACK TOP	EMPEIGNE GUIDACINGOLO	SCHUHOBERTEILS GUIDACINGOLO	ZAPATO ALTO GUIDACINGOLO

-  ALLARGAMENTO IDRAULICO
-  HYDRAULIC EXTENSION
-  ECARTEMENT HYDRAULIQUE

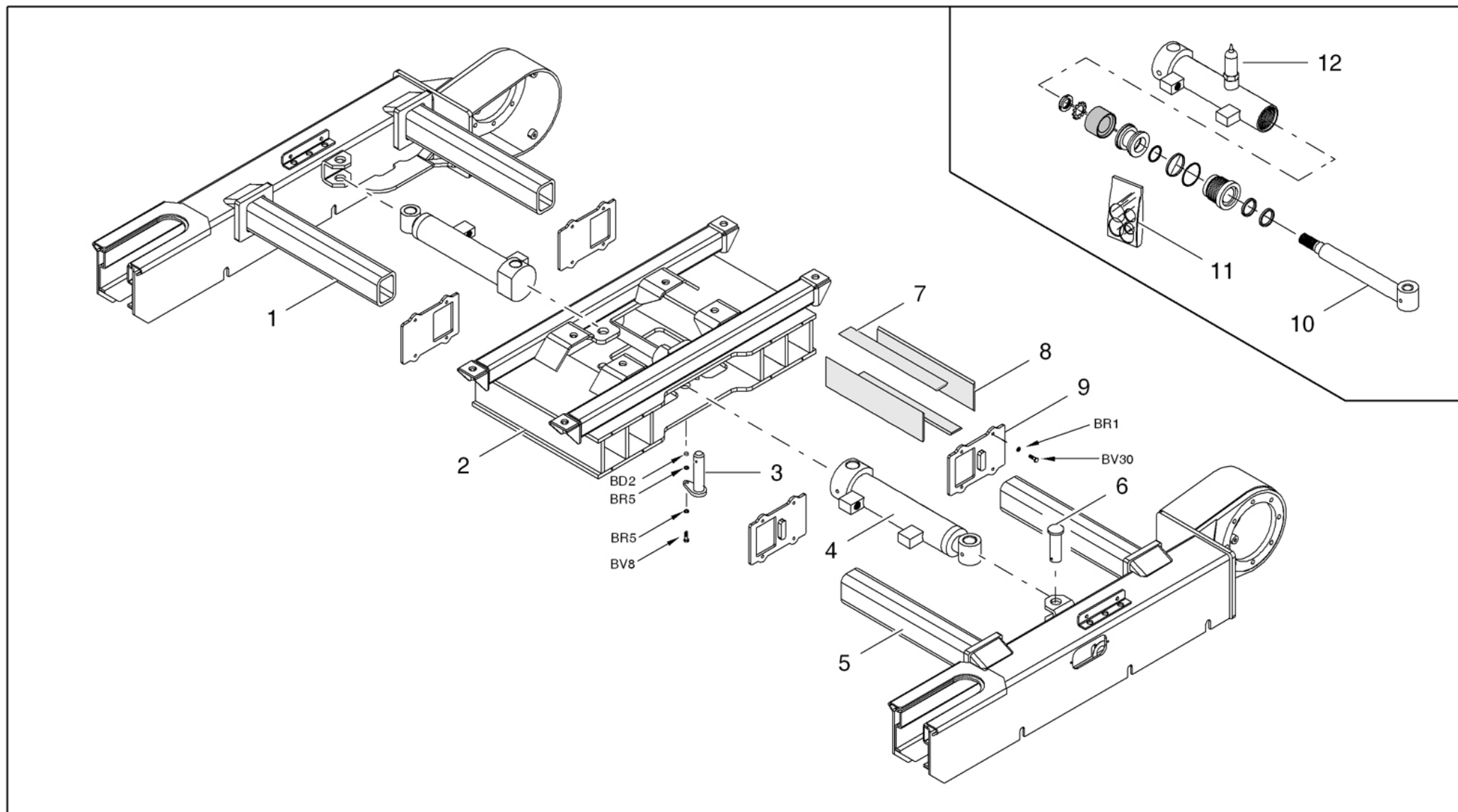
HYDR. SPURWEITENVER STELLEINRICHTUNG 
 EXTENSION HIDRAULICA 







Main color codes:  J1 - JLG Cream,  J2 - JLG Orange,  C4 - Green

 ALLARGAMENTO IDRAULICO

 HYDRAULIC EXTENSION

 ECARTEMENT HYDRAULIQUE
HYDR. SPURWEITENVER STELLEINRICHTUNG EXTENSION HIDRAULICA 





POS	Codice	 Descrizione	 Description	 Designation	 Benennung	 Descripción
1	372494A3	LONGHERONE DESTRO	RIGHT SIDE MEMBER UNDERCARRIAGE	LONGERON DROIT	RIGHT LAENGSTRAEGER	MIEMBRO DEL LADO DERECHO
1	372494H2	LONGHERONE DESTRO	RIGHT SIDE MEMBER UNDERCARRIAGE	LONGERON DROIT	RIGHT LAENGSTRAEGER	MIEMBRO DEL LADO DERECHO
2	372491A3	STRUTTURA CENTRALE SOTTOCARRO	CENTRAL STRUCTURE UNDERCARRIAGE	UNDERTRUCK DE STRUCTURE CENTRALE	ZENTRALE STRUKTUR UNDERTRUCK	UNDERTRUCK ESTRUCTURA CENTRAL
2	372491H2	STRUTTURA CENTRALE SOTTOCARRO	CENTRAL STRUCTURE UNDERCARRIAGE	UNDERTRUCK DE STRUCTURE CENTRALE	ZENTRALE STRUKTUR UNDERTRUCK	UNDERTRUCK ESTRUCTURA CENTRAL
3	06023800	SPINA FONDELLO ALLARGAMENTO	BOTTOM PLUG ENLARGEMENT	BAS PLUG ELARGISSEMENT	UNTEN PLUG ERWEITERUNG	BASE ENCHUFE AMPLIACIÓN
4	27227400	CILINDRO ALLARGAMENTO SOTTOCARRO	CYLINDER ENLARGEMENT UNDERCARRIAGE	UNDERTRUCK D'ELARGISSEMENT BOUTEILLE	ZYLINDER ERWEITERUNG UNDERTRUCK	UNDERTRUCK AMPLIACIÓN DEL CILINDRO
4	272274A3	CILINDRO ALLARGAMENTO SOTTOCARRO	CYLINDER ENLARGEMENT UNDERCARRIAGE	UNDERTRUCK D'ELARGISSEMENT BOUTEILLE	ZYLINDER ERWEITERUNG UNDERTRUCK	UNDERTRUCK AMPLIACIÓN DEL CILINDRO
4	272274H2	CILINDRO ALLARGAMENTO SOTTOCARRO	CYLINDER ENLARGEMENT UNDERCARRIAGE	UNDERTRUCK D'ELARGISSEMENT BOUTEILLE	ZYLINDER ERWEITERUNG UNDERTRUCK	UNDERTRUCK AMPLIACIÓN DEL CILINDRO
5	372495A3	LONGHERONE SINISTRO	LEFT SIDE MEMBER UNDERCARRIAGE	LONGERON DROIT	RIGHT LAENGSTRAEGER	MIEMBRO DEL LADO DERECHO
5	372495H2	LONGHERONE SINISTRO	LEFT SIDE MEMBER UNDERCARRIAGE	LONGERON DROIT	RIGHT LAENGSTRAEGER	MIEMBRO DEL LADO DERECHO
6	04256300	SPINA	PIN	CHEVILLE	STIFT	CLAVIJA
7	07278300	GUIDA ALLARGAMENTO	EXPANSION GUIDE	GLISSIÈRE ÉLARGISSEMENT	FÜHRUNGSVERBREITERUNG	GUÍA DE EXTENSIÓN
8	07278200	GUIDA ALLARGAMENTO	EXPANSION GUIDE	GLISSIÈRE ÉLARGISSEMENT	FÜHRUNGSVERBREITERUNG	GUÍA DE EXTENSIÓN
9	372768A3	COPERCHIO GUIDE ALLARGAMENTO	ENLARGEMENT GUIDE COVER	GUIDE TITRE DE L'ELARGISSEMENT	FÜHRUNGSABDECKUNG ERWEITERUNG	PORTADA DE LA GUÍA AMPLIACIÓN
9	372768H2	COPERCHIO GUIDE ALLARGAMENTO	ENLARGEMENT GUIDE COVER	ELARGISSEMENT GUIDE COUVERTURE	ERWEITERUNG GUIDE COVER	GUÍA DE AMPLIACIÓN COVER



Main color codes:  J1 - JLG Cream,  J2 - JLG Orange,  C4 - Green



 ALLARGAMENTO IDRAULICO

 HYDRAULIC EXTENSION



 ECARTEMENT HYDRAULIQUE
HYDR. SPURWEITENVER STELLEINRICHTUNG EXTENSION HIDRAULICA 

POS	Codice	 Descrizione	 Description	 Designation	 Benennung	 Descripción
10	2722740001	STELO ALLARGAMENTO CARRO	ROD CYLINDER ENLARGEMENT	TIGE D'EXTENSION CAMION	VERLÄNGERUNGSST ANGE TRUCK	EXTENSION ROD TRUCK
11	2722740002	KIT GUARNIZIONI CILINDRO ALLARGAMENTO CARRO	ENLARGEMENT CYLINDER GASKET KIT	ÉLARGISSEMENT CAMION KIT CYLINDRE JOINT	ERWEITERUNG CYLINDER GASKET KIT TRUCK	PLIACIÓN DE JUNTAS CILINDRO TRUCK KIT
12	17329500	MICROINTERRUPTOR E ALLARGAMENTO CARRO N/O COMPLETO DI CAVO E CONNETTORE	WIDENING SYSTEM MICRO SWITCH N/O CONTACT WITH CABLE AND CONNECTOR	MICRO INTERRUPTEUR ELARGISSEMENT AVEC CABLE ET CONNECTEUR	MIKROSCHALTER SPURVERBREITERUN G MIT KABEL UND STECKER	MICROINTERRUPTOR ENSANCHAMIENTO CON CABLE Y CONECTOR



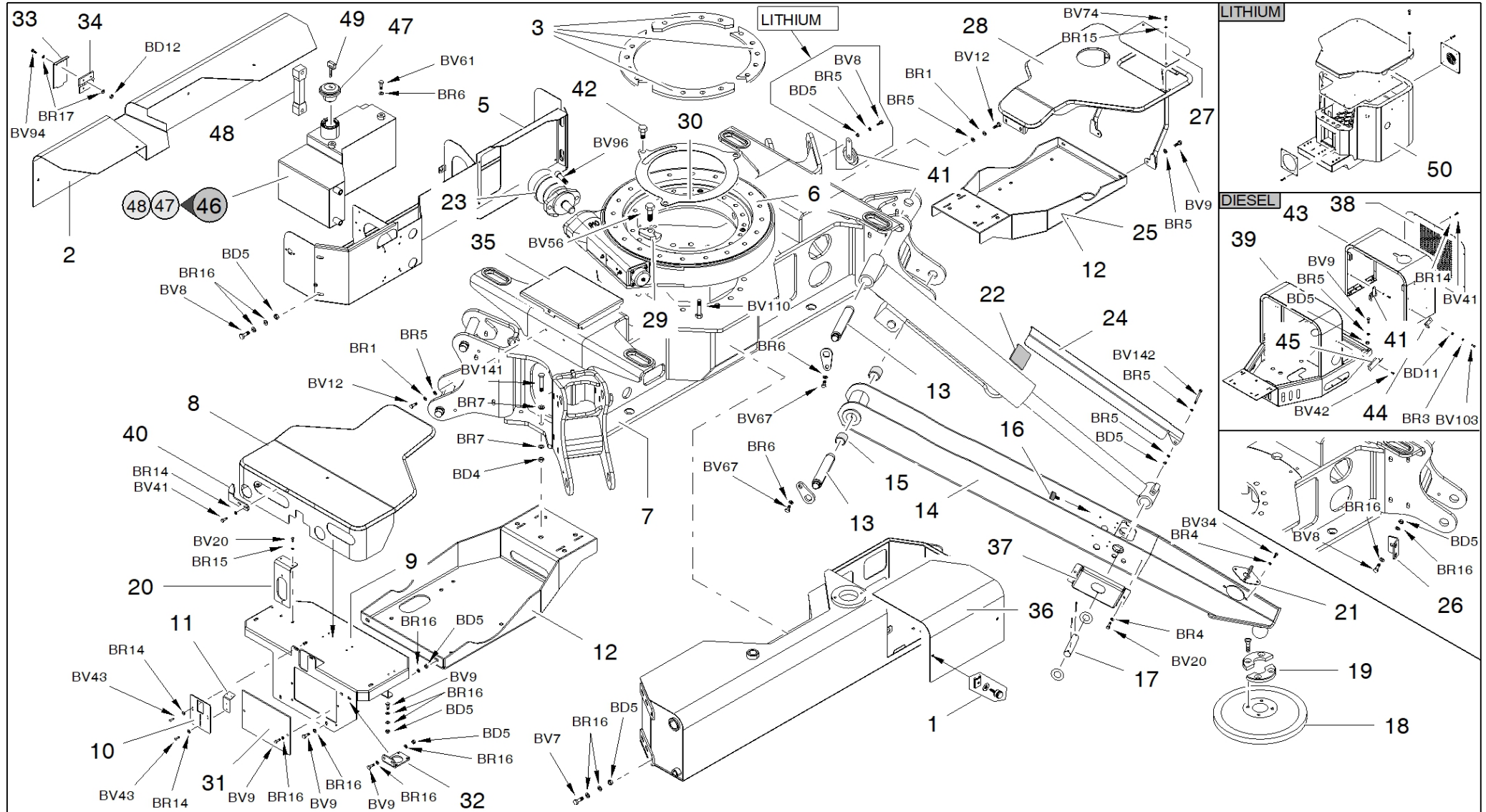

-  BASE TORRETTA
-  TURRET BASE
-  BASE TOURELLE

- ARBEITSTURM 
- BASE TORRETA GIRATORIA 











Main color codes:  J1 - JLG Cream,  J2 - JLG Orange,  C4 - Green

 BASE TORRETTA TURRET BASE BASE TOURELLEARBEITSTURM BASE TORRETTA GIRATORIA 





POS	Codice	 Descrizione	 Description	 Designation	 Benennung	 Descripción
1	07343200	VITE IMPERDIBILE ZIGRINATA CORTA	SHORT IMPERDIBLE KNURLED SCREW	VIS IMPERDABLE	SCHRAUBE	TORNILLO IMPERDIBLE
1	07343300	RICETTACOLO PER VITE IMPERDIBILE	RECEPTACLE FOR IMPERDIBLE SCREW	PRISE DE VIS POUR VIS IMPERDABLE	AUFNAHME FÜR SCHRAUBE	REFUGIO TORNILLO IMPERDIBLE
1	07343400	AGGANCIO PER VITE IMPERDIBILE	COUPLING FOR IMPERDIBLE SCREW	CROCHET VIS IMPERDABLE	HAKEN FÜR SCHRAUBE	GANCHO TORNILLO IMPERDIBLE
2	172726B1	COPERCHIO COMPONENTI ELETTRICI	COVER ELECTRICAL COMPONENTS	COUVRIR LES COMPOSANTS ÉLECTRIQUES	COVER ELEKTROKOMPEN TEN	CUBRIR LOS COMPONENTES ELÉCTRICOS
2	172726C4	COPERCHIO COMPONENTI ELETTRICI	COVER ELECTRICAL COMPONENTS	COUVRIR LES COMPOSANTS ÉLECTRIQUES	COVER ELEKTROKOMPEN TEN	CUBRIR LOS COMPONENTES ELÉCTRICOS
2	172726J0	COPERCHIO COMPONENTI ELETTRICI	COVER ELECTRICAL COMPONENTS	COUVRIR LES COMPOSANTS ÉLECTRIQUES	COVER ELEKTROKOMPEN TEN	CUBRIR LOS COMPONENTES ELÉCTRICOS
2	17312400	COPERCHIO COMPONENTI ELETTRICI VERSIONE DIESEL	ELECTRICAL COMPONENTS COVER DIESEL VERSION	COUVERTURE COMPOSANTS ÉLECTRIQUES DIESEL	COVER ELEKTROKOMPEN TEN DIESEL	CUBRIR LOS COMPONENTES ELÉCTRICOS DIESEL
2	173124BP	COPERCHIO COMPONENTI ELETTRICI VERSIONE DIESEL	ELECTRICAL COMPONENTS COVER DIESEL VERSION	COUVRIR LES COMPOSANTS ÉLECTRIQUES DIESEL	COVER ELEKTROKOMPEN TEN DIESEL	CUBRIR LOS COMPONENTES ELÉCTRICOS DIESEL
2	173124D5	COPERCHIO COMPONENTI ELETTRICI VERSIONE DIESEL	ELECTRICAL COMPONENTS COVER DIESEL VERSION	COUVRIR LES COMPOSANTS ÉLECTRIQUES DIESEL	COVER ELEKTROKOMPEN TEN DIESEL	CUBRIR LOS COMPONENTES ELÉCTRICOS DIESEL
2	173124EM	COPERCHIO COMPONENTI ELETTRICI VERSIONE DIESEL	ELECTRICAL COMPONENTS COVER DIESEL VERSION	COUVRIR LES COMPOSANTS ÉLECTRIQUES DIESEL	COVER ELEKTROKOMPEN TEN DIESEL	CUBRIR LOS COMPONENTES ELÉCTRICOS DIESEL



 BASE TORRETTA TURRET BASE BASE TOURELLEARBEITSTURM BASE TORRETTA GIRATORIA 

POS	Codice	 Descrizione	 Description	 Designation	 Benennung	 Descripción
2	173124J0	COPERCHIO COMPONENTI ELETTRICI VERSIONE DIESEL	ELECTRICAL COMPONENTS COVER DIESEL VERSION	COUVERTURE COMPOSANTS ÉLECTRIQUES DIESEL	COVER ELEKTROKOMPONEN TEN DIESEL	CUBRIR LOS COMPONENTES ELÉCTRICOS DIESEL
2	376837A1	COPERCHIO COMPONENTI ELETTRICI LL2010 BENZINA MK2 (FROM C170000893)	COVER FOR ELECTRICAL ELEMENTS LL2010 GASOLINE MK2 (FROM C170000893)	COUVERTE MK2 (FROM C170000893)	DECKEL MK2 (FROM C170000893)	TAPA MK2 (FROM C170000893)
2	376837A3	COPERCHIO COMPONENTI ELETTRICI LL2010 BENZINA MK2 (FROM C170000893)	COVER FOR ELECTRICAL ELEMENTS LL2010 GASOLINE MK2 (FROM C170000893)	COUVERTE MK2 (FROM C170000893)	DECKEL MK2 (FROM C170000893)	TAPA MK2 (FROM C170000893)
2	376837A7	COPERCHIO COMPONENTI ELETTRICI LL2010 BENZINA MK2 (FROM C170000893)	COVER FOR ELECTRICAL ELEMENTS LL2010 GASOLINE MK2 (FROM C170000893)	COUVERTE MK2 (FROM C170000893)	DECKEL MK2 (FROM C170000893)	TAPA MK2 (FROM C170000893)
2	376837BA	COPERCHIO COMPONENTI ELETTRICI LL2010 BENZINA MK2 (FROM C170000893)	COVER FOR ELECTRICAL ELEMENTS LL2010 GASOLINE MK2 (FROM C170000893)	COUVERTE MK2 (FROM C170000893)	DECKEL MK2 (FROM C170000893)	TAPA MK2 (FROM C170000893)
2	376837BC	COPERCHIO COMPONENTI ELETTRICI LL2010 BENZINA MK2 (FROM C170000893)	COVER FOR ELECTRICAL ELEMENTS LL2010 GASOLINE MK2 (FROM C170000893)	COUVERTE MK2 (FROM C170000893)	DECKEL MK2 (FROM C170000893)	TAPA MK2 (FROM C170000893)
2	376837BP	COPERCHIO COMPONENTI ELETTRICI LL2010 BENZINA MK2 (FROM C170000893)	COVER FOR ELECTRICAL ELEMENTS LL2010 GASOLINE MK2 (FROM C170000893)	COUVERTE MK2 (FROM C170000893)	DECKEL MK2 (FROM C170000893)	TAPA MK2 (FROM C170000893)





Main color codes:  J1 - JLG Cream,  J2 - JLG Orange,  C4 - Green



 BASE TORRETTA TURRET BASE BASE TOURELLEARBEITSTURM BASE TORRETTA GIRATORIA 

POS	Codice	 Descrizione	 Description	 Designation	 Benennung	 Descripción
2	376837C4	COPERCHIO COMPONENTI ELETTRICI LL2010 BENZINA MK2 (FROM C170000893)	COVER FOR ELECTRICAL ELEMENTS LL2010 GASOLINE MK2 (FROM C170000893)	COUVERTE MK2 (FROM C170000893)	DECKEL MK2 (FROM C170000893)	TAPA MK2 (FROM C170000893)
2	376837GC	COPERCHIO COMPONENTI ELETTRICI LL2010 BENZINA MK2 (FROM C170000893)	COVER FOR ELECTRICAL ELEMENTS LL2010 GASOLINE MK2 (FROM C170000893)	COUVERTE MK2 (FROM C170000893)	DECKEL MK2 (FROM C170000893)	TAPA MK2 (FROM C170000893)
2	376837H3	COPERCHIO COMPONENTI ELETTRICI LL2010 BENZINA MK2 (FROM C170000893)	COVER FOR ELECTRICAL ELEMENTS LL2010 GASOLINE MK2 (FROM C170000893)	COUVERTE MK2 (FROM C170000893)	DECKEL MK2 (FROM C170000893)	TAPA MK2 (FROM C170000893)
2	376837J2	COPERCHIO COMPONENTI ELETTRICI LL2010 BENZINA MK2 (FROM C170000893)	COVER FOR ELECTRICAL ELEMENTS LL2010 GASOLINE MK2 (FROM C170000893)	COUVERTE MK2 (FROM C170000893)	DECKEL MK2 (FROM C170000893)	TAPA MK2 (FROM C170000893)
2	376838A1	COPERCHIO COMPONENTI ELETTRICI LL2010 DIESEL MK2 (FROM C170000893)	COVER FOR ELECTRICAL ELEMENTS LL2010 DIESEL MK2 (FROM C170000893)	COUVERTE MK2 (FROM C170000893)	DECKEL MK2 (FROM C170000893)	TAPA MK2 (FROM C170000893)
2	376838A3	COPERCHIO COMPONENTI ELETTRICI LL2010 DIESEL MK2 (FROM C170000893)	COVER FOR ELECTRICAL ELEMENTS LL2010 DIESEL MK2 (FROM C170000893)	COUVERTE MK2 (FROM C170000893)	DECKEL MK2 (FROM C170000893)	TAPA MK2 (FROM C170000893)





Main color codes:  J1 - JLG Cream,  J2 - JLG Orange,  C4 - Green



 BASE TORRETTA TURRET BASE BASE TOURELLEARBEITSTURM BASE TORRETTA GIRATORIA 

POS	Codice	 Descrizione	 Description	 Designation	 Benennung	 Descripción
2	376838A5	COPERCHIO COMPONENTI ELETTRICI LL2010 DIESEL MK2 (FROM C170000893)	COVER FOR ELECTRICAL ELEMENTS LL2010 DIESEL MK2 (FROM C170000893)	COUVERTE MK2 (FROM C170000893)	DECKEL MK2 (FROM C170000893)	TAPA MK2 (FROM C170000893)
2	376838A6	COPERCHIO COMPONENTI ELETTRICI LL2010 DIESEL MK2 (FROM C170000893)	COVER FOR ELECTRICAL ELEMENTS LL2010 DIESEL MK2 (FROM C170000893)	COUVERTE MK2 (FROM C170000893)	DECKEL MK2 (FROM C170000893)	TAPA MK2 (FROM C170000893)
2	376838A7	COPERCHIO COMPONENTI ELETTRICI LL2010 DIESEL MK2 (FROM C170000893)	COVER FOR ELECTRICAL ELEMENTS LL2010 DIESEL MK2 (FROM C170000893)	COUVERTE MK2 (FROM C170000893)	DECKEL MK2 (FROM C170000893)	TAPA MK2 (FROM C170000893)
2	376838A8	COPERCHIO COMPONENTI ELETTRICI LL2010 DIESEL MK2 (FROM C170000893)	COVER FOR ELECTRICAL ELEMENTS LL2010 DIESEL MK2 (FROM C170000893)	COUVERTE MK2 (FROM C170000893)	DECKEL MK2 (FROM C170000893)	TAPA MK2 (FROM C170000893)
2	376838A9	COPERCHIO COMPONENTI ELETTRICI LL2010 DIESEL MK2 (FROM C170000893)	COVER FOR ELECTRICAL ELEMENTS LL2010 DIESEL MK2 (FROM C170000893)	COUVERTE MK2 (FROM C170000893)	DECKEL MK2 (FROM C170000893)	TAPA MK2 (FROM C170000893)
2	376838AG	COPERCHIO COMPONENTI ELETTRICI LL2010 DIESEL MK2 (FROM C170000893)	COVER FOR ELECTRICAL ELEMENTS LL2010 DIESEL MK2 (FROM C170000893)	COUVERTE MK2 (FROM C170000893)	DECKEL MK2 (FROM C170000893)	TAPA MK2 (FROM C170000893)





Main color codes:  J1 - JLG Cream,  J2 - JLG Orange,  C4 - Green



 BASE TORRETTA TURRET BASE BASE TOURELLEARBEITSTURM BASE TORRETTA GIRATORIA 

POS	Codice	 Descrizione	 Description	 Designation	 Benennung	 Descripción
2	376838B1	COPERCHIO COMPONENTI ELETTRICI LL2010 DIESEL MK2 (FROM C170000893)	COVER FOR ELECTRICAL ELEMENTS LL2010 DIESEL MK2 (FROM C170000893)	COUVERTE MK2 (FROM C170000893)	DECKEL MK2 (FROM C170000893)	TAPA MK2 (FROM C170000893)
2	376838BP	COPERCHIO COMPONENTI ELETTRICI LL2010 DIESEL MK2 (FROM C170000893)	COVER FOR ELECTRICAL ELEMENTS LL2010 DIESEL MK2 (FROM C170000893)	COUVERTE MK2 (FROM C170000893)	DECKEL MK2 (FROM C170000893)	TAPA MK2 (FROM C170000893)
2	376838CL	COPERCHIO COMPONENTI ELETTRICI LL2010 DIESEL MK2 (FROM C170000893)	COVER FOR ELECTRICAL ELEMENTS LL2010 DIESEL MK2 (FROM C170000893)	COUVERTE MK2 (FROM C170000893)	DECKEL MK2 (FROM C170000893)	TAPA MK2 (FROM C170000893)
2	376838CO	COPERCHIO COMPONENTI ELETTRICI LL2010 DIESEL MK2 (FROM C170000893)	COVER FOR ELECTRICAL ELEMENTS LL2010 DIESEL MK2 (FROM C170000893)	COUVERTE MK2 (FROM C170000893)	DECKEL MK2 (FROM C170000893)	TAPA MK2 (FROM C170000893)
2	376838D5	COPERCHIO COMPONENTI ELETTRICI LL2010 DIESEL MK2 (FROM C170000893)	COVER FOR ELECTRICAL ELEMENTS LL2010 DIESEL MK2 (FROM C170000893)	COUVERTE MK2 (FROM C170000893)	DECKEL MK2 (FROM C170000893)	TAPA MK2 (FROM C170000893)
2	376838DI	COPERCHIO COMPONENTI ELETTRICI LL2010 DIESEL MK2 (FROM C170000893)	COVER FOR ELECTRICAL ELEMENTS LL2010 DIESEL MK2 (FROM C170000893)	COUVERTE MK2 (FROM C170000893)	DECKEL MK2 (FROM C170000893)	TAPA MK2 (FROM C170000893)



Main color codes:  J1 - JLG Cream,  J2 - JLG Orange,  C4 - Green



 BASE TORRETTA TURRET BASE BASE TOURELLEARBEITSTURM BASE TORRETTA GIRATORIA 

POS	Codice	 Descrizione	 Description	 Designation	 Benennung	 Descripció
2	376838EM	COPERCHIO COMPONENTI ELETTRICI LL2010 DIESEL MK2 (FROM C170000893)	COVER FOR ELECTRICAL ELEMENTS LL2010 DIESEL MK2 (FROM C170000893)	COUVERTE MK2 (FROM C170000893)	DECKEL MK2 (FROM C170000893)	TAPA MK2 (FROM C170000893)
2	376838EW	COPERCHIO COMPONENTI ELETTRICI LL2010 DIESEL MK2 (FROM C170000893)	COVER FOR ELECTRICAL ELEMENTS LL2010 DIESEL MK2 (FROM C170000893)	COUVERTE MK2 (FROM C170000893)	DECKEL MK2 (FROM C170000893)	TAPA MK2 (FROM C170000893)
2	376838GB	COPERCHIO COMPONENTI ELETTRICI LL2010 DIESEL MK2 (FROM C170000893)	COVER FOR ELECTRICAL ELEMENTS LL2010 DIESEL MK2 (FROM C170000893)	COUVERTE MK2 (FROM C170000893)	DECKEL MK2 (FROM C170000893)	TAPA MK2 (FROM C170000893)
2	376838H1	COPERCHIO COMPONENTI ELETTRICI LL2010 DIESEL MK2 (FROM C170000893)	COVER FOR ELECTRICAL ELEMENTS LL2010 DIESEL MK2 (FROM C170000893)	COUVERTE MK2 (FROM C170000893)	DECKEL MK2 (FROM C170000893)	TAPA MK2 (FROM C170000893)
2	376838J2	COPERCHIO COMPONENTI ELETTRICI LL2010 DIESEL MK2 (FROM C170000893)	COVER FOR ELECTRICAL ELEMENTS LL2010 DIESEL MK2 (FROM C170000893)	COUVERTE MK2 (FROM C170000893)	DECKEL MK2 (FROM C170000893)	TAPA MK2 (FROM C170000893)
3	176090Y1	KIT 4 SPESSORI FISSAGGIO SUPPORTO BRACCI 15MM CATAFORESI	KIT 4 THICKNESSES FIXING SUPPORT ARMS 15MM	KIT 4 CALES	KIT VON 4 STÄRKEN	KIT 4 ESPESORES
5	359447A1	TIRANTE	TIE ROD	TIRANT	TURMGESTÄNGE	TIRANTE
5	359447A3	TIRANTE	TIE ROD	TIRANT	TURMGESTÄNGE	TIRANTE
5	359447A9	TIRANTE	TIE ROD	TIRANT	TURMGESTÄNGE	TIRANTE
5	359447B1	TIRANTE	TIE ROD	TIRANT	TURMGESTÄNGE	TIRANTE
5	359447BP	TIRANTE	TIE ROD	TIRANT	TURMGESTÄNGE	TIRANTE

Main color codes:  J1 - JLG Cream,  J2 - JLG Orange,  C4 - Green



 BASE TORRETTA TURRET BASE BASE TOURELLEARBEITSTURM BASE TORRETTA GIRATORIA 

POS	Codice	 Descrizione	 Description	 Designation	 Benennung	 Descripción
5	359447D4	TIRANTE	TIE ROD	TIRANT	TURMGESTÄNGE	TIRANTE
5	359447GB	TIRANTE	TIE ROD	TIRANT	TURMGESTÄNGE	TIRANTE
5	359447H1	TIRANTE	TIE ROD	TIRANT	TURMGESTÄNGE	TIRANTE
5	359447J2	TIRANTE JIB	TIE ROD JIB	TIRANT	ZUGSTANGE	TIRANTE
5	372721A1	SCATOLA COMPONENTI ELETTRICI SALDATA	ELECTRICAL COMPONENTS SEALED BOX	BOÎTE SCELLÉE COMPOSANTS ÉLECTRIQUES	SEALED BOX ELEKTROKOMPONEN TEN	CAJA SELLADA COMPONENTES ELÉCTRICOS
5	372721A3	SCATOLA COMPONENTI ELETTRICI SALDATA	ELECTRICAL COMPONENTS SEALED BOX	BOÎTE SCELLÉE COMPOSANTS ÉLECTRIQUES	SEALED BOX ELEKTROKOMPONEN TEN	CAJA SELLADA COMPONENTES ELÉCTRICOS
5	372721A5	SCATOLA COMPONENTI ELETTRICI SALDATA	ELECTRICAL COMPONENTS SEALED BOX	SULJETTU BOX SÄHKÖOSIA	SEALED BOX ELEKTROKOMPONEN TEN	CAJA SELLADA COMPONENTES ELÉCTRICOS
5	372721A6	SCATOLA COMPONENTI ELETTRICI SALDATA	ELECTRICAL COMPONENTS SEALED BOX	BOÎTE SCELLÉE COMPOSANTS ÉLECTRIQUES	SEALED BOX ELEKTROKOMPONEN TEN	CAJA SELLADA COMPONENTES ELÉCTRICOS
5	372721A7	SCATOLA COMPONENTI ELETTRICI SALDATA	ELECTRICAL COMPONENTS SEALED BOX	BOÎTE SCELLÉE COMPOSANTS ÉLECTRIQUES	SEALED BOX ELEKTROKOMPONEN TEN	CAJA SELLADA COMPONENTES ELÉCTRICOS
5	372721A8	SCATOLA COMPONENTI ELETTRICI SALDATA	ELECTRICAL COMPONENTS SEALED BOX	BOÎTE SCELLÉE COMPOSANTS ÉLECTRIQUES	SEALED BOX ELEKTROKOMPONEN TEN	CAJA SELLADA COMPONENTES ELÉCTRICOS
5	372721A9	SCATOLA COMPONENTI ELETTRICI SALDATA	ELECTRICAL COMPONENTS SEALED BOX	BOÎTE SCELLÉE COMPOSANTS ÉLECTRIQUES	SEALED BOX ELEKTROKOMPONEN TEN	CAJA SELLADA COMPONENTES ELÉCTRICOS
5	372721AG	SCATOLA COMPONENTI ELETTRICI SALDATA	ELECTRICAL COMPONENTS SEALED BOX	COMPOSANTS ÉLECTRIQUES BOÎTE SCELLÉE	ELEKTROKOMPONEN TEN SEALED BOX	COMPONENTES ELÉCTRICOS CAJA SELLADA
5	372721B1	SCATOLA COMPONENTI ELETTRICI SALDATA	ELECTRICAL COMPONENTS SEALED BOX	BOÎTE SCELLÉE COMPOSANTS ÉLECTRIQUES	SEALED BOX ELEKTROKOMPONEN TEN	CAJA SELLADA COMPONENTES ELÉCTRICOS
5	372721BA	SCATOLA COMPONENTI ELETTRICI SALDATA	ELECTRICAL COMPONENTS SEALED BOX	BOÎTE SCELLÉE COMPOSANTS ÉLECTRIQUES	SEALED BOX ELEKTROKOMPONEN TEN	CAJA SELLADA COMPONENTES ELÉCTRICOS

Main color codes:  J1 - JLG Cream,  J2 - JLG Orange,  C4 - Green

 BASE TORRETTA TURRET BASE BASE TOURELLEARBEITSTURM BASE TORRETTA GIRATORIA 





POS	Codice	 Descrizione	 Description	 Designation	 Benennung	 Descripcìon
5	372721BC	SCATOLA COMPONENTI ELETTRICI SALDATA	ELECTRICAL COMPONENTS SEALED BOX	BOÎTE SCELLÉE COMPOSANTS ÉLECTRIQUES	SEALED BOX ELEKTROKOMPONEN TEN	CAJA SELLADA COMPONENTES ELÉCTRICOS
5	372721BP	SCATOLA COMPONENTI ELETTRICI SALDATA	ELECTRICAL COMPONENTS SEALED BOX	BOÎTE SCELLÉE COMPOSANTS ÉLECTRIQUES	SEALED BOX ELEKTROKOMPONEN TEN	CAJA SELLADA COMPONENTES ELÉCTRICOS
5	372721C4	SCATOLA COMPONENTI ELETTRICI SALDATA	ELECTRICAL COMPONENTS SEALED BOX	BOÎTE SCELLÉE COMPOSANTS ÉLECTRIQUES	SEALED BOX ELEKTROKOMPONEN TEN	CAJA SELLADA COMPONENTES ELÉCTRICOS
5	372721CL	SCATOLA COMPONENTI ELETTRICI SALDATA	ELECTRICAL COMPONENTS SEALED BOX	COMPOSANTS ÉLECTRIQUES BOÎTE SCELLÉE	ELEKTROKOMPONEN TEN SEALED BOX	COMPONENTES ELÉCTRICOS CAJA SELLADA
5	372721CO	SCATOLA COMPONENTI ELETTRICI SALDATA	ELECTRICAL COMPONENTS SEALED BOX	BOÎTE SCELLÉE COMPOSANTS ÉLECTRIQUES	SEALED BOX ELEKTROKOMPONEN TEN	CAJA SELLADA COMPONENTES ELÉCTRICOS
5	372721D5	SCATOLA COMPONENTI ELETTRICI SALDATA	ELECTRICAL COMPONENTS SEALED BOX	BOÎTE SCELLÉE COMPOSANTS ÉLECTRIQUES	SEALED BOX ELEKTROKOMPONEN TEN	CAJA SELLADA COMPONENTES ELÉCTRICOS
5	372721DI	SCATOLA COMPONENTI ELETTRICI SALDATA	ELECTRICAL COMPONENTS SEALED BOX	BOÎTE SCELLÉE COMPOSANTS ÉLECTRIQUES	SEALED BOX ELEKTROKOMPONEN TEN	CAJA SELLADA COMPONENTES ELÉCTRICOS
5	372721EM	SCATOLA COMPONENTI ELETTRICI SALDATA	ELECTRICAL COMPONENTS SEALED BOX	BOÎTE SCELLÉE COMPOSANTS ÉLECTRIQUES	SEALED BOX ELEKTROKOMPONEN TEN	CAJA SELLADA COMPONENTES ELÉCTRICOS
5	372721EW	SCATOLA COMPONENTI ELETTRICI SALDATA	ELECTRICAL COMPONENTS SEALED BOX	BOÎTE SCELLÉE COMPOSANTS ÉLECTRIQUES	SEALED BOX ELEKTROKOMPONEN TEN	CAJA SELLADA COMPONENTES ELÉCTRICOS
5	372721GB	SCATOLA COMPONENTI ELETTRICI SALDATA	ELECTRICAL COMPONENTS SEALED BOX	BOÎTE SCELLÉE COMPOSANTS ÉLECTRIQUES	SEALED BOX ELEKTROKOMPONEN TEN	CAJA SELLADA COMPONENTES ELÉCTRICOS
5	372721GC	SCATOLA COMPONENTI ELETTRICI SALDATA	ELECTRICAL COMPONENTS SEALED BOX	SULJETTU BOX SÄHKÖOSIA	SEALED BOX ELEKTROKOMPONEN TEN	CAJA SELLADA COMPONENTES ELÉCTRICOS



Main color codes:  J1 - JLG Cream,  J2 - JLG Orange,  C4 - Green

 BASE TORRETTA

 TURRET BASE



 BASE TOURELLE
ARBEITSTURM BASE TORRETTA GIRATORIA 

POS	Codice	 Descrizione	 Description	 Designation	 Benennung	 Descripción
5	372721H1	SCATOLA COMPONENTI ELETTRICI SALDATA	ELECTRICAL COMPONENTS SEALED BOX	COMPOSANTS ÉLECTRIQUES BOÎTE SCELLÉE	ELEKTROKOMPONENTEN SEALED BOX	COMPONENTES ELÉCTRICOS CAJA SELLADA
5	372721H3	SCATOLA COMPONENTI ELETTRICI SALDATA	ELECTRICAL COMPONENTS SEALED BOX	BOÎTE SCELLÉE COMPOSANTS ÉLECTRIQUES	SEALED BOX ELEKTROKOMPONENTEN TEN	CAJA SELLADA COMPONENTES ELÉCTRICOS
5	372721J2	SCATOLA COMPONENTI ELETTRICI SALDATA	ELECTRICAL COMPONENTS SEALED BOX	COMPOSANTS ÉLECTRIQUES BOÎTE SCELLÉE	ELEKTROKOMPONENTEN TEN SEALED BOX	COMPONENTES ELÉCTRICOS CAJA SELLADA
6	26459300	RALLA	FIFTH WHEEL	COURONNE DENTÉE	DREHKRANZ	TEJUELO
6	264593A3	RALLA	FIFTH WHEEL	COURONNE DENTÉE	DREHKRANZ	TEJUELO
6	264593H2	RALLA	FIFTH WHEEL	COURONNE DENTÉE	DREHKRANZ	TEJUELO
7	372514A3	ASSIEME BASE SALDATA	BASE WELDED ASSEMBLY	BASE SOUDÉS ENSEMBLE	BASE ZUSAMMENGESCHWEISST	BASE SOLDADAS ENTRE SÍ
7	372514H2	ASSIEME BASE SALDATA	BASE WELDED ASSEMBLY	BASE SOUDÉS ENSEMBLE	BASE ZUSAMMENGESCHWEISST	BASE SOLDADAS ENTRE SÍ
8	372772A1	PROTEZIONE DISTRIBUTORI BASE SALDATA	WELDED COVER FOR GROUND HYDRAULIC DISTRIBUTOR	DISTRIBUTEURS DE BASE SUR LA PROTECTION DE SOUDURE	HÄNDLER SCHUTZ BASE GESCHWEISSTE	PROTECCIÓN DE DISTRIBUIDORES BASE SOLDADA
8	372772A3	PROTEZIONE DISTRIBUTORI BASE SALDATA	WELDED COVER FOR GROUND HYDRAULIC DISTRIBUTOR	DISTRIBUTEURS DE BASE SUR LA PROTECTION DE SOUDURE	HÄNDLER SCHUTZ BASE GESCHWEISSTE	PROTECCIÓN DE DISTRIBUIDORES BASE SOLDADA
8	372772A5	PROTEZIONE DISTRIBUTORI BASE SALDATA	WELDED COVER FOR GROUND HYDRAULIC DISTRIBUTOR	GUARD BASE SOUDÉE DISTRIBUTEURS	GUARD BASE GESCHWEISSTE DISTRIBUTORS	GUARDIA BASE SOLDADA DISTRIBUIDORES
8	372772A6	PROTEZIONE DISTRIBUTORI BASE SALDATA	WELDED COVER FOR GROUND HYDRAULIC DISTRIBUTOR	DISTRIBUTEURS DE BASE SUR LA PROTECTION DE SOUDURE	HÄNDLER SCHUTZ BASE GESCHWEISSTE	PROTECCIÓN DE DISTRIBUIDORES BASE SOLDADA

Main color codes:  J1 - JLG Cream,  J2 - JLG Orange,  C4 - Green

 BASE TORRETTA TURRET BASE BASE TOURELLEARBEITSTURM BASE TORRETTA GIRATORIA 

POS	Codice	 Descrizione	 Description	 Designation	 Benennung	 Descripción
8	372772A7	PROTEZIONE DISTRIBUTORI BASE SALDATA	WELDED COVER FOR GROUND HYDRAULIC DISTRIBUTOR	DISTRIBUTEURS DE BASE SUR LA PROTECTION DE SOUDURE	HÄNDLER SCHUTZ BASE GESCHWEISSTE	PROTECCIÓN DE DISTRIBUIDORES BASE SOLDADA
8	372772A8	PROTEZIONE DISTRIBUTORI BASE SALDATA	WELDED COVER FOR GROUND HYDRAULIC DISTRIBUTO	DISTRIBUTEURS DE BASE SUR LA PROTECTION DE SOUDURE	HÄNDLER SCHUTZ BASE GESCHWEISSTE	PROTECCIÓN DE DISTRIBUIDORES BASE SOLDADA
8	372772A9	PROTEZIONE DISTRIBUTORI BASE SALDATA	WELDED COVER FOR GROUND HYDRAULIC DISTRIBUTOR	GUARD BASE SOUDÉE DISTRIBUTEURS	GUARD BASE GESCHWEISSTE DISTRIBUTORS	GUARDIA BASE SOLDADA DISTRIBUIDORES
8	372772AG	PROTEZIONE DISTRIBUTORI BASE SALDATA	WELDED COVER FOR GROUND HYDRAULIC DISTRIBUTOR	GUARD BASE SOUDÉE DISTRIBUTEURS	GUARD BASE GESCHWEISSTE DISTRIBUTORS	GUARDIA BASE SOLDADA DISTRIBUIDORES
8	372772B1	PROTEZIONE DISTRIBUTORI BASE SALDATA	WELDED COVER FOR GROUND HYDRAULIC DISTRIBUTOR	DISTRIBUTEURS DE BASE SUR LA PROTECTION DE SOUDURE	HÄNDLER SCHUTZ BASE GESCHWEISSTE	PROTECCIÓN DE DISTRIBUIDORES BASE SOLDADA
8	372772BA	PROTEZIONE DISTRIBUTORI BASE SALDATA	WELDED COVER FOR GROUND HYDRAULIC DISTRIBUTOR	DISTRIBUTEURS DE BASE SUR LA PROTECTION DE SOUDURE	HÄNDLER SCHUTZ BASE GESCHWEISSTE	PROTECCIÓN DE DISTRIBUIDORES BASE SOLDADA
8	372772BC	PROTEZIONE DISTRIBUTORI BASE SALDATA	WELDED COVER FOR GROUND HYDRAULIC DISTRIBUTOR	DISTRIBUTEURS DE BASE SUR LA PROTECTION DE SOUDURE	HÄNDLER SCHUTZ BASE GESCHWEISSTE	PROTECCIÓN DE DISTRIBUIDORES BASE SOLDADA
8	372772BP	PROTEZIONE DISTRIBUTORI BASE SALDATA	WELDED COVER FOR GROUND HYDRAULIC DISTRIBUTOR	DISTRIBUTEURS DE BASE SUR LA PROTECTION DE SOUDURE	HÄNDLER SCHUTZ BASE GESCHWEISSTE	PROTECCIÓN DE DISTRIBUIDORES BASE SOLDADA
8	372772C4	PROTEZIONE DISTRIBUTORI BASE SALDATA	WELDED COVER FOR GROUND HYDRAULIC DISTRIBUTOR	DISTRIBUTEURS DE BASE SUR LA PROTECTION DE SOUDURE	HÄNDLER SCHUTZ BASE GESCHWEISSTE	PROTECCIÓN DE DISTRIBUIDORES BASE SOLDADA



Main color codes:  J1 - JLG Cream,  J2 - JLG Orange,  C4 - Green

 BASE TORRETTA





 TURRET BASE



 BASE TOURELLE
ARBEITSTURM BASE TORRETTA GIRATORIA 

POS	Codice	 Descrizione	 Description	 Designation	 Benennung	 Descripción
8	372772CL	PROTEZIONE DISTRIBUTORI BASE SALDATA	WELDED COVER FOR GROUND HYDRAULIC DISTRIBUTOR	GUARD BASE SOUDÉE DISTRIBUTEURS	GUARD BASE GESCHWEISSTE DISTRIBUTORS	GUARDIA BASE SOLDADA DISTRIBUIDORES
8	372772CO	PROTEZIONE DISTRIBUTORI BASE SALDATA	WELDED COVER FOR GROUND HYDRAULIC DISTRIBUTOR	GUARD BASE SOUDÉE DISTRIBUTEURS	GUARD BASE GESCHWEISSTE DISTRIBUTORS	GUARDIA BASE SOLDADA DISTRIBUIDORES
8	372772D5	PROTEZIONE DISTRIBUTORI BASE SALDATA	WELDED COVER FOR GROUND HYDRAULIC DISTRIBUTOR	DISTRIBUTEURS DE BASE SUR LA PROTECTION DE SOUDURE	HÄNDLER SCHUTZ BASE GESCHWEISSTE	PROTECCIÓN DE DISTRIBUIDORES BASE SOLDADA
8	372772DI	PROTEZIONE DISTRIBUTORI BASE SALDATA	WELDED COVER FOR GROUND HYDRAULIC DISTRIBUTOR	DISTRIBUTEURS DE BASE SUR LA PROTECTION DE SOUDURE	HÄNDLER SCHUTZ BASE GESCHWEISSTE	PROTECCIÓN DE DISTRIBUIDORES BASE SOLDADA
8	372772EM	PROTEZIONE DISTRIBUTORI BASE SALDATA	WELDED COVER FOR GROUND HYDRAULIC DISTRIBUTOR	DISTRIBUTEURS DE BASE SUR LA PROTECTION DE SOUDURE	HÄNDLER SCHUTZ BASE GESCHWEISSTE	PROTECCIÓN DE DISTRIBUIDORES BASE SOLDADA
8	372772EW	PROTEZIONE DISTRIBUTORI BASE SALDATA	WELDED COVER FOR GROUND HYDRAULIC DISTRIBUTOR	DISTRIBUTEURS DE BASE SUR LA PROTECTION DE SOUDURE	HÄNDLER SCHUTZ BASE GESCHWEISSTE	PROTECCIÓN DE DISTRIBUIDORES BASE SOLDADA
8	372772GB	PROTEZIONE DISTRIBUTORI BASE SALDATA	WELDED COVER FOR GROUND HYDRAULIC DISTRIBUTOR	DISTRIBUTEURS DE BASE SUR LA PROTECTION DE SOUDURE	HÄNDLER SCHUTZ BASE GESCHWEISSTE	PROTECCIÓN DE DISTRIBUIDORES BASE SOLDADA
8	372772GC	PROTEZIONE DISTRIBUTORI BASE SALDATA	WELDED COVER FOR GROUND HYDRAULIC DISTRIBUTOR	DISTRIBUTEURS DE BASE SUR LA PROTECTION DE SOUDURE	HÄNDLER SCHUTZ BASE GESCHWEISSTE	PROTECCIÓN DE DISTRIBUIDORES BASE SOLDADA
8	372772H1	PROTEZIONE DISTRIBUTORI BASE SALDATA	WELDED COVER FOR GROUND HYDRAULIC DISTRIBUTOR	DISTRIBUTEURS DE BASE SUR LA PROTECTION DE SOUDURE	HÄNDLER SCHUTZ BASE GESCHWEISSTE	PROTECCIÓN DE DISTRIBUIDORES BASE SOLDADA





Main color codes:  J1 - JLG Cream,  J2 - JLG Orange,  C4 - Green



 BASE TORRETTA TURRET BASE BASE TOURELLEARBEITSTURM BASE TORRETTA GIRATORIA 

POS	Codice	 Descrizione	 Description	 Designation	 Benennung	 Descripció
8	372772H2	PROTEZIONE DISTRIBUTORI BASE SALDATA	WELDED COVER FOR GROUND HYDRAULIC DISTRIBUTOR	GUARD BASE SOUDÉE DISTRIBUTEURS	GUARD BASE GESCHWEISSTE DISTRIBUTORS	GUARDIA BASE SOLDADA DISTRIBUIDORES
8	372772H3	PROTEZIONE DISTRIBUTORI BASE SALDATA	WELDED COVER FOR GROUND HYDRAULIC DISTRIBUTOR	GUARD BASE SOUDÉE DISTRIBUTEURS	GUARD BASE GESCHWEISSTE DISTRIBUTORS	GUARDIA BASE SOLDADA DISTRIBUIDORES
8	372772J2	PROTEZIONE DISTRIBUTORI BASE SALDATA	WELDED COVER FOR GROUND HYDRAULIC DISTRIBUTOR	GUARD BASE SOUDÉE DISTRIBUTEURS	GUARD BASE GESCHWEISSTE DISTRIBUTORS	GUARDIA BASE SOLDADA DISTRIBUIDORES
9	072699A1	SUPPORTO	SUPPORT	SOUTIEN	SUPPORT	APOYO
9	072699A3	SUPPORTO	SUPPORT	SOUTIEN	SUPPORT	APOYO
9	072699A5	SUPPORTO	SUPPORT	SOUTIEN	SUPPORT	APOYO
9	072699A6	SUPPORTO	SUPPORT	SOUTIEN	SUPPORT	APOYO
9	072699A7	SUPPORTO	SUPPORT	SOUTIEN	SUPPORT	APOYO
9	072699A8	SUPPORTO	SUPPORT	SOUTIEN	SUPPORT	APOYO
9	072699A9	SUPPORTO	SUPPORT	SOUTIEN	SUPPORT	APOYO
9	072699AG	SUPPORTO	SUPPORT	SOUTIEN	SUPPORT	APOYO
9	072699B1	SUPPORTO	SUPPORT	SOUTIEN	SUPPORT	APOYO
9	072699BA	SUPPORTO	SUPPORT	SOUTIEN	SUPPORT	APOYO
9	072699BC	SUPPORTO	SUPPORT	SOUTIEN	SUPPORT	APOYO
9	072699BP	SUPPORTO	SUPPORT	SOUTIEN	SUPPORT	APOYO
9	072699C4	SUPPORTO	SUPPORT	SOUTIEN	SUPPORT	APOYO
9	072699CL	SUPPORTO	SUPPORT	SOUTIEN	SUPPORT	APOYO
9	072699CO	SUPPORTO	SUPPORT	SOUTIEN	SUPPORT	APOYO
9	072699D5	SUPPORTO	SUPPORT	SOUTIEN	SUPPORT	APOYO
9	072699DI	SUPPORTO	SUPPORT	SOUTIEN	SUPPORT	APOYO
9	072699EM	SUPPORTO	SUPPORT	SOUTIEN	SUPPORT	APOYO
9	072699EW	SUPPORTO	SUPPORT	SOUTIEN	SUPPORT	APOYO
9	072699GB	SUPPORTO	SUPPORT	SOUTIEN	SUPPORT	APOYO
9	072699GC	SUPPORTO	SUPPORT	SOUTIEN	SUPPORT	APOYO
9	072699H1	SUPPORTO	SUPPORT	SOUTIEN	SUPPORT	APOYO
9	072699H3	SUPPORTO	SUPPORT	SOUTIEN	SUPPORT	APOYO
9	072699J2	SUPPORTO	SUPPORT	SOUTIEN	SUPPORT	APOYO





Main color codes:  J1 - JLG Cream,  J2 - JLG Orange,  C4 - Green



 BASE TORRETTA TURRET BASE BASE TOURELLEARBEITSTURM BASE TORRETTA GIRATORIA 

POS	Codice	 Descrizione	 Description	 Designation	 Benennung	 Descripción
10	061187Y1	PIASTRA	PLATE	PLAQUE	PLATTE	PLACA
11	061185Y1	LAMIERA PIEGATA	FOLDED PLATE	TÔLE PLIÉE	BLECH GEBOGEN	CHAPA DOBLADA
12	372691A1	SUPPORTO MOTORE BENZINA	PETROL ENGINE SUPPORT	MOTEUR ESSENCE DE SOUTIEN	MOTOR SUPPORT FUEL	SOPORTE DE MOTOR DE GASOLINA
12	372691A3	SUPPORTO MOTORE BENZINA	PETROL ENGINE SUPPORT	MOTEUR ESSENCE DE SOUTIEN	MOTOR SUPPORT FUEL	SOPORTE DE MOTOR DE GASOLINA
12	372691A5	SUPPORTO MOTORE BENZINA	PETROL ENGINE SUPPORT	MOTEUR DE CARBURANT	MOTOR SUPPORT FUEL	SOPORTE DE MOTOR DE GASOLINA
12	372691A6	SUPPORTO MOTORE BENZINA	PETROL ENGINE SUPPORT	MOTEUR ESSENCE DE SOUTIEN	MOTOR SUPPORT FUEL	SOPORTE DE MOTOR DE GASOLINA
12	372691A7	SUPPORTO MOTORE BENZINA	PETROL ENGINE SUPPORT	MOTEUR ESSENCE DE SOUTIEN	MOTOR SUPPORT FUEL	SOPORTE DE MOTOR DE GASOLINA
12	372691A8	SUPPORTO MOTORE BENZINA	PETROL ENGINE SUPPORT	MOTEUR ESSENCE DE SOUTIEN	MOTOR SUPPORT FUEL	SOPORTE DE MOTOR DE GASOLINA
12	372691A9	SUPPORTO MOTORE BENZINA	PETROL ENGINE SUPPORT	MOTEUR ESSENCE DE SOUTIEN	MOTOR SUPPORT FUEL	SOPORTE DE MOTOR DE GASOLINA
12	372691AG	SUPPORTO MOTORE BENZINA	PETROL ENGINE SUPPORT	ESSENCE SUPPORT MOTEUR	BENZINMOTOR SUPPORT	MOTOR DE GASOLINA DE APOYO
12	372691B1	SUPPORTO MOTORE BENZINA	PETROL ENGINE SUPPORT	MOTEUR ESSENCE DE SOUTIEN	MOTOR SUPPORT FUEL	SOPORTE DE MOTOR DE GASOLINA
12	372691BA	SUPPORTO MOTORE BENZINA	PETROL ENGINE SUPPORT	MOTEUR ESSENCE DE SOUTIEN	MOTOR SUPPORT FUEL	SOPORTE DE MOTOR DE GASOLINA
12	372691BC	SUPPORTO MOTORE BENZINA	PETROL ENGINE SUPPORT	MOTEUR ESSENCE DE SOUTIEN	MOTOR SUPPORT FUEL	SOPORTE DE MOTOR DE GASOLINA
12	372691BP	SUPPORTO MOTORE BENZINA	PETROL ENGINE SUPPORT	MOTEUR DE CARBURANT	MOTOR SUPPORT FUEL	SOPORTE DE MOTOR DE GASOLINA
12	372691C4	SUPPORTO MOTORE BENZINA	PETROL ENGINE SUPPORT	MOTEUR ESSENCE DE SOUTIEN	MOTOR SUPPORT FUEL	SOPORTE DE MOTOR DE GASOLINA
12	372691CL	SUPPORTO MOTORE BENZINA	PETROL ENGINE SUPPORT	ESSENCE SUPPORT MOTEUR	BENZINMOTOR SUPPORT	MOTOR DE GASOLINA DE APOYO
12	372691CO	SUPPORTO MOTORE BENZINA	PETROL ENGINE SUPPORT	MOTEUR ESSENCE DE SOUTIEN	MOTOR SUPPORT FUEL	SOPORTE DE MOTOR DE GASOLINA
12	372691D5	SUPPORTO MOTORE BENZINA	PETROL ENGINE SUPPORT	MOTEUR ESSENCE DE SOUTIEN	MOTOR SUPPORT FUEL	SOPORTE DE MOTOR DE GASOLINA

Main color codes:  J1 - JLG Cream,  J2 - JLG Orange,  C4 - Green



 BASE TORRETTA TURRET BASE BASE TOURELLEARBEITSTURM BASE TORRETTA GIRATORIA 

POS	Codice	 Descrizione	 Description	 Designation	 Benennung	 Descripción
12	372691DI	SUPPORTO MOTORE BENZINA	PETROL ENGINE SUPPORT	MOTEUR DE CARBURANT	MOTOR SUPPORT FUEL	SOPORTE DE MOTOR DE GASOLINA
12	372691EM	SUPPORTO MOTORE BENZINA	PETROL ENGINE SUPPORT	MOTEUR ESSENCE DE SOUTIEN	MOTOR SUPPORT FUEL	SOPORTE DE MOTOR DE GASOLINA
12	372691EW	SUPPORTO MOTORE BENZINA	PETROL ENGINE SUPPORT	MOTEUR ESSENCE DE SOUTIEN	MOTOR SUPPORT FUEL	SOPORTE DE MOTOR DE GASOLINA
12	372691GB	SUPPORTO MOTORE BENZINA	PETROL ENGINE SUPPORT	MOTEUR ESSENCE DE SOUTIEN	MOTOR SUPPORT FUEL	SOPORTE DE MOTOR DE GASOLINA
12	372691GC	SUPPORTO MOTORE BENZINA	PETROL ENGINE SUPPORT	MOTEUR DE CARBURANT	MOTOR SUPPORT FUEL	SOPORTE DE MOTOR DE GASOLINA
12	372691H1	SUPPORTO MOTORE BENZINA	PETROL ENGINE SUPPORT	ESSENCE SUPPORT MOTEUR	BENZINMOTOR SUPPORT	MOTOR DE GASOLINA DE APOYO
12	372691H3	SUPPORTO MOTORE BENZINA	PETROL ENGINE SUPPORT	MOTEUR ESSENCE DE SOUTIEN	MOTOR SUPPORT FUEL	SOPORTE DE MOTOR DE GASOLINA
12	372691J2	SUPPORTO MOTORE BENZINA	PETROL ENGINE SUPPORT	ESSENCE SUPPORT MOTEUR	BENZINMOTOR SUPPORT	MOTOR DE GASOLINA DE APOYO
13	07131600	SPINA	PIN	CHEVILLE	STIF	CLAVIJA
14	17252700	STABILIZZATORE COMPLETO	COMPLETE STABILIZER	STABILISATEUR COMPLET	STABILIZER KOMPLETT	ESTABILIZADOR COMPLETO
14	172527B1	STABILIZZATORE COMPLETO	COMPLETE STABILIZER	STABILISATEUR COMPLET	STABILIZER KOMPLETT	ESTABILIZADOR COMPLETO
14	172527BP	STABILIZZATORE COMPLETO	COMPLETE STABILIZER	STABILISATEUR COMPLET	STABILIZER KOMPLETT	ESTABILIZADOR COMPLETO
14	172527C4	STABILIZZATORE COMPLETO	COMPLETE STABILIZER	STABILISATEUR COMPLET	STABILIZER KOMPLETT	ESTABILIZADOR COMPLETO
14	172527D5	STABILIZZATORE COMPLETO	COMPLETE STABILIZER	STABILISATEUR COMPLET	STABILIZER KOMPLETT	ESTABILIZADOR COMPLETO
14	172527EM	STABILIZZATORE COMPLETO	COMPLETE STABILIZER	STABILISATEUR COMPLET	STABILIZER KOMPLETT	ESTABILIZADOR COMPLETO
14	172527J0	STABILIZZATORE COMPLETO	COMPLETE STABILIZER	STABILISATEUR COMPLET	STABILIZER KOMPLETT	ESTABILIZADOR COMPLETO
14	176835A1	STABILIZZATORE COMPLETO MK2 (FROM C170000893)	COMPLETE STABILIZER MK2 (FROM C170000893)	STABILISATEUR COMPLET MK2 (FROM C170000893)	STABILIZER KOMPLETT MK2 (FROM C170000893)	ESTABILIZADOR COMPLETO MK2 (FROM C170000893)

Main color codes:  J1 - JLG Cream,  J2 - JLG Orange,  C4 - Green



 BASE TORRETTA TURRET BASE BASE TOURELLEARBEITSTURM BASE TORRETTA GIRATORIA 

POS	Codice	 Descrizione	 Description	 Designation	 Benennung	 Descripción
14	176835A3	STABILIZZATORE COMPLETO MK2 (FROM C170000893)	COMPLETE STABILIZER MK2 (FROM C170000893)	STABILISATEUR COMPLET MK2 (FROM C170000893)	STABILIZER KOMPLETT MK2 (FROM C170000893)	ESTABILIZADOR COMPLETO MK2 (FROM C170000893)
14	176835A5	STABILIZZATORE COMPLETO MK2 (FROM C170000893)	COMPLETE STABILIZER MK2 (FROM C170000893)	STABILISATEUR COMPLET MK2 (FROM C170000893)	STABILIZER KOMPLETT MK2 (FROM C170000893)	ESTABILIZADOR COMPLETO MK2 (FROM C170000893)
14	176835A6	STABILIZZATORE COMPLETO MK2 (FROM C170000893)	COMPLETE STABILIZER MK2 (FROM C170000893)	STABILISATEUR COMPLET MK2 (FROM C170000893)	STABILIZER KOMPLETT MK2 (FROM C170000893)	ESTABILIZADOR COMPLETO MK2 (FROM C170000893)
14	176835A7	STABILIZZATORE COMPLETO MK2 (FROM C170000893)	COMPLETE STABILIZER MK2 (FROM C170000893)	STABILISATEUR COMPLET MK2 (FROM C170000893)	STABILIZER KOMPLETT MK2 (FROM C170000893)	ESTABILIZADOR COMPLETO MK2 (FROM C170000893)
14	176835A8	STABILIZZATORE COMPLETO MK2 (FROM C170000893)	COMPLETE STABILIZER MK2 (FROM C170000893)	STABILISATEUR COMPLET MK2 (FROM C170000893)	STABILIZER KOMPLETT MK2 (FROM C170000893)	ESTABILIZADOR COMPLETO MK2 (FROM C170000893)
14	176835A9	STABILIZZATORE COMPLETO MK2 (FROM C170000893)	COMPLETE STABILIZER MK2 (FROM C170000893)	STABILISATEUR COMPLET MK2 (FROM C170000893)	STABILIZER KOMPLETT MK2 (FROM C170000893)	ESTABILIZADOR COMPLETO MK2 (FROM C170000893)
14	176835AG	STABILIZZATORE COMPLETO MK2 (FROM C170000893)	COMPLETE STABILIZER MK2 (FROM C170000893)	STABILISATEUR COMPLET MK2 (FROM C170000893)	STABILIZER KOMPLETT MK2 (FROM C170000893)	ESTABILIZADOR COMPLETO MK2 (FROM C170000893)
14	176835B1	STABILIZZATORE COMPLETO MK2 (FROM C170000893)	COMPLETE STABILIZER MK2 (FROM C170000893)	STABILISATEUR COMPLET MK2 (FROM C170000893)	STABILIZER KOMPLETT MK2 (FROM C170000893)	ESTABILIZADOR COMPLETO MK2 (FROM C170000893)
14	176835BA	STABILIZZATORE COMPLETO MK2 (FROM C170000893)	COMPLETE STABILIZER MK2 (FROM C170000893)	STABILISATEUR COMPLET MK2 (FROM C170000893)	STABILIZER KOMPLETT MK2 (FROM C170000893)	ESTABILIZADOR COMPLETO MK2 (FROM C170000893)
14	176835BC	STABILIZZATORE COMPLETO MK2 (FROM C170000893)	COMPLETE STABILIZER MK2 (FROM C170000893)	STABILISATEUR COMPLET MK2 (FROM C170000893)	STABILIZER KOMPLETT MK2 (FROM C170000893)	ESTABILIZADOR COMPLETO MK2 (FROM C170000893)
14	176835BP	STABILIZZATORE COMPLETO MK2 (FROM C170000893)	COMPLETE STABILIZER MK2 (FROM C170000893)	STABILISATEUR COMPLET MK2 (FROM C170000893)	STABILIZER KOMPLETT MK2 (FROM C170000893)	ESTABILIZADOR COMPLETO MK2 (FROM C170000893)

Main color codes:  J1 - JLG Cream,  J2 - JLG Orange,  C4 - Green

 BASE TORRETTA TURRET BASE BASE TOURELLEARBEITSTURM BASE TORRETTA GIRATORIA 

POS	Codice	 Descrizione	 Description	 Designation	 Benennung	 Descripción
14	176835C4	STABILIZZATORE COMPLETO MK2 (FROM C170000893)	COMPLETE STABILIZER MK2 (FROM C170000893)	STABILISATEUR COMPLET MK2 (FROM C170000893)	STABILIZER KOMPLETT MK2 (FROM C170000893)	ESTABILIZADOR COMPLETO MK2 (FROM C170000893)
14	176835CL	STABILIZZATORE COMPLETO MK2 (FROM C170000893)	COMPLETE STABILIZER MK2 (FROM C170000893)	STABILISATEUR COMPLET MK2 (FROM C170000893)	STABILIZER KOMPLETT MK2 (FROM C170000893)	ESTABILIZADOR COMPLETO MK2 (FROM C170000893)
14	176835CO	STABILIZZATORE COMPLETO MK2 (FROM C170000893)	COMPLETE STABILIZER MK2 (FROM C170000893)	STABILISATEUR COMPLET MK2 (FROM C170000893)	STABILIZER KOMPLETT MK2 (FROM C170000893)	ESTABILIZADOR COMPLETO MK2 (FROM C170000893)
14	176835D5	STABILIZZATORE COMPLETO MK2 (FROM C170000893)	COMPLETE STABILIZER MK2 (FROM C170000893)	STABILISATEUR COMPLET MK2 (FROM C170000893)	STABILIZER KOMPLETT MK2 (FROM C170000893)	ESTABILIZADOR COMPLETO MK2 (FROM C170000893)
14	176835DI	STABILIZZATORE COMPLETO MK2 (FROM C170000893)	COMPLETE STABILIZER MK2 (FROM C170000893)	STABILISATEUR COMPLET MK2 (FROM C170000893)	STABILIZER KOMPLETT MK2 (FROM C170000893)	ESTABILIZADOR COMPLETO MK2 (FROM C170000893)
14	176835EM	STABILIZZATORE COMPLETO MK2 (FROM C170000893)	COMPLETE STABILIZER MK2 (FROM C170000893)	STABILISATEUR COMPLET MK2 (FROM C170000893)	STABILIZER KOMPLETT MK2 (FROM C170000893)	ESTABILIZADOR COMPLETO MK2 (FROM C170000893)
14	176835EW	STABILIZZATORE COMPLETO MK2 (FROM C170000893)	COMPLETE STABILIZER MK2 (FROM C170000893)	STABILISATEUR COMPLET MK2 (FROM C170000893)	STABILIZER KOMPLETT MK2 (FROM C170000893)	ESTABILIZADOR COMPLETO MK2 (FROM C170000893)
14	176835GB	STABILIZZATORE COMPLETO MK2 (FROM C170000893)	COMPLETE STABILIZER MK2 (FROM C170000893)	STABILISATEUR COMPLET MK2 (FROM C170000893)	STABILIZER KOMPLETT MK2 (FROM C170000893)	ESTABILIZADOR COMPLETO MK2 (FROM C170000893)
14	176835GC	STABILIZZATORE COMPLETO MK2 (FROM C170000893)	COMPLETE STABILIZER MK2 (FROM C170000893)	STABILISATEUR COMPLET MK2 (FROM C170000893)	STABILIZER KOMPLETT MK2 (FROM C170000893)	ESTABILIZADOR COMPLETO MK2 (FROM C170000893)
14	176835H1	STABILIZZATORE COMPLETO MK2 (FROM C170000893)	COMPLETE STABILIZER MK2 (FROM C170000893)	STABILISATEUR COMPLET MK2 (FROM C170000893)	STABILIZER KOMPLETT MK2 (FROM C170000893)	ESTABILIZADOR COMPLETO MK2 (FROM C170000893)
14	176835H2	STABILIZZATORE COMPLETO MK2 (FROM C170000893)	COMPLETE STABILIZER MK2 (FROM C170000893)	STABILISATEUR COMPLET MK2 (FROM C170000893)	STABILIZER KOMPLETT MK2 (FROM C170000893)	ESTABILIZADOR COMPLETO MK2 (FROM C170000893)



Main color codes:  J1 - JLG Cream,  J2 - JLG Orange,  C4 - Green

 BASE TORRETTA





 TURRET BASE



 BASE TOURELLE
ARBEITSTURM BASE TORRETTA GIRATORIA 

POS	Codice	 Descrizione	 Description	 Designation	 Benennung	 Descripción
14	176835H3	STABILIZZATORE COMPLETO MK2 (FROM C170000893)	COMPLETE STABILIZER MK2 (FROM C170000893)	STABILISATEUR COMPLET MK2 (FROM C170000893)	STABILIZER KOMPLETT MK2 (FROM C170000893)	ESTABILIZADOR COMPLETO MK2 (FROM C170000893)
14	176835J2	STABILIZZATORE COMPLETO MK2 (FROM C170000893)	COMPLETE STABILIZER MK2 (FROM C170000893)	STABILISATEUR COMPLET MK2 (FROM C170000893)	STABILIZER KOMPLETT MK2 (FROM C170000893)	ESTABILIZADOR COMPLETO MK2 (FROM C170000893)
15	06586200	BOCCOLA	BUSH	DOUILLE	BUCHSE	CASQUILLO
16	28185800	ANTIVIBRANTE	ANTI-VIBRATING	ANTI - VIBRANT	VIBRATIONSDÄMPFE R	ANTIVIBRANTE
17	07270400	SPINA	PIN	CHEVILLE	STIF	CLAVIJA
18	05446300	DISCO	DISK	DISQUE	SCHEIBE	DISCO
19	073147Y1	SEMIFLANGIA	HALF FLANGE	DEMI-BRIDE	HALB FLANSCH	SEMI BRIDA
20	068910Y1	STAFFA	BRACKET	ÉTRIER	HALTEBÜGEL	ESTRIBO
20	076966H3	CARTER PROTEZIONE CENTRALINO MK2 (DA C170000893)	CARTER PROTECTION SWITCHBOARD MK2 (FROM C170000893)	CARTER	KURBELGEHÄUSE	CÁRTER
21	37270200	SUPPORTO SPIA STABILIZZATORE	LIGHT STABILIZER SUPPORT	LUMIÈRE DE SOUTIEN DE STABILISATION	LICHTSCHUTZMITTEL SUPPORT	LUZ DE SOPORTE ESTABILIZADOR
21	376018A3	SUPPORTO SPIA STABILIZZATORE (FOR LL2010-X20JP- X600AJ MK2 FROM C170000893)	OUTRIGGER LIGHT SUPPORT (FOR LL2010-X20JP-X600AJ MK2 FROM C170000893)	SUPPORT LUMIÈRE STABILISATEUR (FOR LL2010-X20JP-X600AJ MK2 FROM C170000893)	LICHTHALTERUNG (FOR LL2010-X20JP- X600AJ MK2 FROM C170000893)	SOPORTE LUZ (FOR LL2010-X20JP-X600AJ MK2 FROM C170000893)
21	376018H2	SUPPORTO SPIA STABILIZZATORE (FOR LL2010-X20JP- X600AJ MK2 FROM C170000893)	OUTRIGGER LIGHT SUPPORT (FOR LL2010-X20JP-X600AJ MK2 FROM C170000893)	SUPPORT LUMIÈRE STABILISATEUR (FOR LL2010-X20JP-X600AJ MK2 FROM C170000893)	LICHTHALTERUNG (FOR LL2010-X20JP- X600AJ MK2 FROM C170000893)	SOPORTE LUZ (FOR LL2010-X20JP-X600AJ MK2 FROM C170000893)
21	376018NV	SUPPORTO SPIA STABILIZZATORE (FOR LL2010-X20JP- X600AJ MK2 FROM C170000893)	LIGHT STABILIZER SUPPORT (FOR LL2010-X20JP-X600AJ MK2 FROM C170000893)	LUMIÈRE DE SOUTIEN DE STABILISATION (FOR LL2010-X20JP- X600AJ MK2 FROM C170000893)	LICHTSCHUTZMITTEL SUPPORT (FOR LL2010-X20JP-X600AJ MK2 FROM C170000893)	LUZ DE SOPORTE ESTABILIZADOR (FOR LL2010-X20JP-X600AJ MK2 FROM C170000893)





Main color codes:  J1 - JLG Cream,  J2 - JLG Orange,  C4 - Green



 BASE TORRETTA TURRET BASE BASE TOURELLEARBEITSTURM BASE TORRETTA GIRATORIA 

POS	Codice	 Descrizione	 Description	 Designation	 Benennung	 Descripción
23	261308A3	MOTORE DI ROTAZIONE	ROTARY MOTOR	MOTEUR DE ROTATION	ROTATIONSMOTOR	MOTOR DE ROTACIÓN
23	261308H2	MOTORE DI ROTAZIONE	ROTARY MOTOR	MOTEUR DE ROTATION	ROTATIONSMOTOR	MOTOR DE ROTACIÓN
24	072700A3	CARTER DI PROTEZIONE	PROTECTION COVER	CARTER DE DE PROTECTION	CARTER VON SCHUTZ	CARTER DE PROTECCIÓN
24	072700H2	CARTER DI PROTEZIONE	PROTECTION COVER	CARTER DE PROTECTION	CARTER VON SCHUTZ	CARTER DE PROTECCIÓN
25	372843A5	SUPPORTO MOTORE DIESEL	DIESEL ENGINE SUPPORT	DIESEL SUPPORT MOTEUR	DIESEL MOTOR SUPPORT	MOTOR DIESEL DE APOYO
25	372843A9	SUPPORTO MOTORE DIESEL	DIESEL ENGINE SUPPORT	DIESEL SUPPORT MOTEUR	DIESEL MOTOR SUPPORT	MOTOR DIESEL DE APOYO
25	372843AG	SUPPORTO MOTORE DIESEL	DIESEL ENGINE SUPPORT	DIESEL SUPPORT MOTEUR	DIESEL MOTOR SUPPORT	MOTOR DIESEL DE APOYO
25	372843BP	SUPPORTO MOTORE DIESEL	DIESEL ENGINE SUPPORT	MOTEUR DIESEL SUPPORT	DIESEL MOTOR SUPPORT	DIESEL MOTOR SUPPORT
25	372843CL	SUPPORTO MOTORE DIESEL	DIESEL ENGINE SUPPORT	DIESEL SUPPORT MOTEUR	DIESEL MOTOR SUPPORT	MOTOR DIESEL DE APOYO
25	372843CO	SUPPORTO MOTORE DIESEL	DIESEL ENGINE SUPPORT	DIESEL SUPPORT MOTEUR	DIESEL MOTOR SUPPORT	MOTOR DIESEL DE APOYO
25	372843D5	SUPPORTO MOTORE DIESEL	DIESEL ENGINE SUPPORT	MOTEUR DIESEL SUPPORT	DIESEL MOTOR SUPPORT	MOTOR DIESEL DE APOYO
25	372843EM	SUPPORTO MOTORE DIESEL	DIESEL ENGINE SUPPORT	MOTEUR DIESEL SUPPORT	DIESEL MOTOR SUPPORT	MOTOR DIESEL DE APOYO
25	372843H1	SUPPORTO MOTORE DIESEL	DIESEL ENGINE SUPPORT	DIESEL SUPPORT MOTEUR	DIESEL MOTOR SUPPORT	MOTOR DIESEL DE APOYO
25	372843J2	SUPPORTO MOTORE DIESEL	DIESEL ENGINE SUPPORT	DIESEL SUPPORT MOTEUR	DIESEL MOTOR SUPPORT	MOTOR DIESEL DE APOYO
25	380502A1	SUPPORTO MOTORE KUBOTA	SUPPORT	SUPPORT	HALTERUNG	SOPORTE
25	380502A3	SUPPORTO MOTORE KUBOTA	SUPPORT	SUPPORT	HALTERUNG	SOPORTE
25	380502A6	SUPPORT MOTORE KUBOTA	SUPPORT	SUPPORT	HALTERUNG	SOPORTE

Main color codes:  J1 - JLG Cream,  J2 - JLG Orange,  C4 - Green



 BASE TORRETTA TURRET BASE BASE TOURELLEARBEITSTURM BASE TORRETTA GIRATORIA 

POS	Codice	 Descrizione	 Description	 Designation	 Benennung	 Descripción
25	380502A7	SUPPORTO MOTORE KUBOTA	SUPPORT	SUPPORT	HALTERUNG	SOPORTE
25	380502A8	SUPPORTO MOTORE KUBOTA	SUPPORT	SUPPORT	HALTERUNG	SOPORTE
25	380502A9	SUPPORTO MOTORE KUBOTA	SUPPORT	SUPPORT	HALTERUNG	SOPORTE
25	380502B1	SUPPORTO MOTORE KUBOTA	SUPPORT	SUPPORT	HALTERUNG	SOPORTE
25	380502BP	SUPPORTO MOTORE KUBOTA	SUPPORT	SUPPORT	HALTERUNG	SOPORTE
25	380502CO	SUPPORTO MOTORE KUBOTA	SUPPORT	SUPPORT	HALTERUNG	SOPORTE
25	380502D5	SUPPORTO MOTORE KUBOTA	SUPPORT	SUPPORT	HALTERUNG	SOPORTE
25	380502DI	SUPPORTO MOTORE KUBOTA	SUPPORT	SUPPORT	HALTERUNG	SOPORTE
25	380502EM	SUPPORT MOTORE KUBOTA	SUPPORT	SUPPORT	HALTERUNG	SOPORTE
25	380502EW	SUPPORT MOTORE KUBOTA	SUPPORT	SUPPORT	HALTERUNG	SOPORTE
25	380502GB	SUPPORTO MOTORE KUBOTA	SUPPORT	SUPPORT	HALTERUNG	SOPORTE
25	380502H1	SUPPORTO MOTORE	ENGINE SUPPORT	SUPPORT MOTEUR	MOTOR HALTERUNG	SOPORTE MOTOR
25	380502J2	SUPPORTO MOTORE	ENGINE SUPPORT	SUPPORT MOTEUR	MOTOR HALTERUNG	SOPORTE MOTOR
26	055629H3	STAFFA	BRACKET	ÉTRIER	HALTEBÜGEL	ESTRIBO
27	07141100	COPERCHIO FILTRO ARIA MOTORE HONDA	AIR FILTER COVER HONDA MOTOR	COUVERCLE	DECKEL	TAPA
28	172776A1	ASSIEME PROTEZIONE MOTORE BENZINA COMPLETA	ASSEMBLY PETROL ENGINE COMPLETE PROTECTION	PROTECTION MOTEUR ESSENCE COMPLET	BENZINMOTOR VOLLSTÄNDIGEN SCHUTZ	MOTOR DE GASOLINA DE PROTECCIÓN COMPLETA





Main color codes:  J1 - JLG Cream,  J2 - JLG Orange,  C4 - Green



 BASE TORRETTA TURRET BASE BASE TOURELLEARBEITSTURM BASE TORRETTA GIRATORIA 

POS	Codice	 Descrizione	 Description	 Designation	 Benennung	 Descripción
28	172776A3	ASSIEME PROTEZIONE MOTORE BENZINA COMPLETA	ASSEMBLY PETROL ENGINE COMPLETE PROTECTION	PROTECTION MOTEUR ESSENCE COMPLET	BENZINMOTOR VOLLSTÄNDIGEN SCHUTZ	MOTOR DE GASOLINA DE PROTECCIÓN COMPLETA
28	172776A7	ASSIEME PROTEZIONE MOTORE BENZINA COMPLETA	ASSEMBLY PETROL ENGINE COMPLETE PROTECTION	PROTECTION MOTEUR ESSENCE COMPLET	BENZINMOTOR VOLLSTÄNDIGEN SCHUTZ	MOTOR DE GASOLINA DE PROTECCIÓN COMPLETA
28	172776B1	ASSIEME PROTEZIONE MOTORE BENZINA COMPLETA	ASSEMBLY PETROL ENGINE COMPLETE PROTECTION	PROTECTION MOTEUR ESSENCE COMPLET	BENZINMOTOR VOLLSTÄNDIGEN SCHUTZ	MOTOR DE GASOLINA DE PROTECCIÓN COMPLETA
28	172776BA	ASSIEME PROTEZIONE MOTORE BENZINA COMPLETA	ASSEMBLY PETROL ENGINE COMPLETE PROTECTION	PROTECTION MOTEUR ESSENCE COMPLET	BENZINMOTOR VOLLSTÄNDIGEN SCHUTZ	MOTOR DE GASOLINA DE PROTECCIÓN COMPLETA
28	172776BP	ASSIEME PROTEZIONE MOTORE BENZINA COMPLETA	ASSEMBLY PETROL ENGINE COMPLETE PROTECTION	PROTECTION MOTEUR ESSENCE COMPLET	BENZINMOTOR VOLLSTÄNDIGEN SCHUTZ	MOTOR DE GASOLINA DE PROTECCIÓN COMPLETA
28	172776GC	ASSIEME PROTEZIONE MOTORE BENZINA COMPLETA	ASSEMBLY PETROL ENGINE COMPLETE PROTECTION	PROTECTION MOTEUR ESSENCE COMPLET	BENZINMOTOR VOLLSTÄNDIGEN SCHUTZ	MOTOR DE GASOLINA DE PROTECCIÓN COMPLETA
28	172776H3	ASSIEME PROTEZIONE MOTORE BENZINA COMPLETA	ASSEMBLY PETROL ENGINE COMPLETE PROTECTION	PROTECTION MOTEUR ESSENCE COMPLET	BENZINMOTOR VOLLSTÄNDIGEN SCHUTZ	MOTOR DE GASOLINA DE PROTECCIÓN COMPLETA
28	172776J2	ASSIEME PROTEZIONE MOTORE BENZINA COMPLETA	ASSEMBLY PETROL ENGINE COMPLETE PROTECTION	PROTECTION MOTEUR ESSENCE COMPLET	BENZINMOTOR VOLLSTÄNDIGEN SCHUTZ	MOTOR DE GASOLINA DE PROTECCIÓN COMPLETA
29	065511Y1	FERMO	RETAINER	ARRÊT	HALTERUNG	BLOQUE





Main color codes:  J1 - JLG Cream,  J2 - JLG Orange,  C4 - Green



 BASE TORRETTA TURRET BASE BASE TOURELLEARBEITSTURM BASE TORRETTA GIRATORIA 

POS	Codice	 Descrizione	 Description	 Designation	 Benennung	 Descripción
30	072786Y1	ANELLO DI RISCANTRO PER SENSORE ROTAZIONE	RING FEEDBACK SENSOR FOR ROTATION	RING SONDE DE JAUGE POUR LA ROTATION	RING-SENSOR FÜR DIE DREHUNG	ANILLO SENSOR DE CALIBRE DE ROTACIÓN
31	072839H3	CARTER	COVER	PLAT	FLAT	CARTER
32	069587H3	PIEGATO FISSAGGIO SPINA ELETTRICA 16A	FIXING FOLDED ELECTRIC PLUG 16A	TÔLE PLIÉE	BLECH GEBOGEN	CHAPA DOBLADA
33	072282A1	COPERCHIO	COVER	COUVERCLE	DECKEL	TAPA
33	072282A3	COPERCHIO	COVER	COUVERCLE	DECKEL	TAPA
33	072282A5	COPERCHIO	COVER	COUVERCLE	DECKEL	TAPA
33	072282A6	COPERCHIO	COVER	COUVERCLE	DECKEL	TAPA
33	072282A7	COPERCHIO	COVER	COUVERCLE	DECKEL	TAPA
33	072282A8	COPERCHIO	COVER	COUVERCLE	DECKEL	TAPA
33	072282A9	COPERCHIO	COVER	COUVERCLE	DECKEL	TAPA
33	072282AG	COPERCHIO	COVER	COUVERCLE	DECKEL	TAPA
33	072282B1	COPERCHIO	COVER	COUVERCLE	DECKEL	TAPA
33	072282BA	COPERCHIO	COVER	COUVERCLE	DECKEL	TAPA
33	072282BC	COPERCHIO	COVER	COUVERCLE	DECKEL	TAPA
33	072282BP	COPERCHIO	COVER	COUVERCLE	DECKEL	TAPA
33	072282C4	COPERCHIO	COVER	COUVERCLE	DECKEL	TAPA
33	072282CL	COPERCHIO	COVER	COUVERCLE	DECKEL	TAPA
33	072282CO	COPERCHIO	COVER	COUVERCLE	DECKEL	TAPA
33	072282D5	COPERCHIO	COVER	COUVERCLE	DECKEL	TAPA
33	072282DI	COPERCHIO	COVER	COUVERCLE	DECKEL	TAPA
33	072282EM	COPERCHIO	COVER	COUVERCLE	DECKEL	TAPA
33	072282EW	COPERCHIO	COVER	COUVERCLE	DECKEL	TAPA
33	072282GB	COPERCHIO	COVER	COUVERCLE	DECKEL	TAPA
33	072282GC	COPERCHIO	COVER	COUVERCLE	DECKEL	TAPA
33	072282H1	COPERCHIO	COVER	COUVERCLE	DECKEL	TAPA
33	072282H3	COPERCHIO	COVER	COUVERCLE	DECKEL	TAPA
33	072282J2	COPERCHIO	COVER	COUVERCLE	DECKEL	TAPA
34	07178700	CERNIERA CON CONTROLLO DELLA POSIZIONE	HINGES WITH POSITION CONTROL	CHARNIÈRE	SCHARNIER	BISAGRA

Main color codes:  J1 - JLG Cream,  J2 - JLG Orange,  C4 - Green

 BASE TORRETTA TURRET BASE BASE TOURELLEARBEITSTURM BASE TORRETTA GIRATORIA 

POS	Codice	 Descrizione	 Description	 Designation	 Benennung	 Descripción
34	07189900	CERNIERA A OSCILLAZIONE LIBERA	HINGE SWING FREE	CHARNIÈRE	SCHARNIER	BISAGRA
35	173505A3	PIEGATO SPESSORE VANO FORCHE LL2010 RAL5015	BENT FORKS SHAFT THICKNESS	SUPPORT	HALTERUNG	SOPORTE
35	173505H2	PIEGATO SPESSORE VANO FORCHE LL2010 HINOWA GRAY	BENT FORKS SHAFT THICKNESS	SUPPORT	HALTERUNG	SOPORTE
36	072690A1	COPERCHIO	COVER	COUVERTURE	DECKEL	CUBIERTA
36	072690A3	COPERCHIO	COVER	COUVERTURE	DECKEL	CUBIERTA
36	072690A5	COPERCHIO	COVER	COUVERTURE	DECKEL	CUBIERTA
36	072690A6	COPERCHIO	COVER	COUVERTURE	DECKEL	CUBIERTA
36	072690A7	COPERCHIO	COVER	COUVERTURE	DECKEL	CUBIERTA
36	072690A8	COPERCHIO	COVER	COUVERTURE	DECKEL	CUBIERTA
36	072690A9	COPERCHIO	COVER	COUVERTURE	DECKEL	CUBIERTA
36	072690AG	COPERCHIO	COVER	COUVERTURE	DECKEL	CUBIERTA
36	072690B1	COPERCHIO	COVER	COUVERTURE	DECKEL	CUBIERTA
36	072690BA	COPERCHIO	COVER	COUVERTURE	DECKEL	CUBIERTA
36	072690BC	COPERCHIO	COVER	COUVERTURE	DECKEL	CUBIERTA
36	072690BP	COPERCHIO	COVER	COUVERTURE	DECKEL	CUBIERTA
36	072690C4	COPERCHIO	COVER	COUVERTURE	DECKEL	CUBIERTA
36	072690CL	COPERCHIO	COVER	COUVERTURE	DECKEL	CUBIERTA
36	072690CO	COPERCHIO	COVER	COUVERTURE	DECKEL	CUBIERTA
36	072690D5	COPERCHIO	COVER	COUVERTURE	DECKEL	CUBIERTA
36	072690DI	COPERCHIO	COVER	COUVERTURE	DECKEL	CUBIERTA
36	072690EM	COPERCHIO	COVER	COUVERTURE	DECKEL	CUBIERTA
36	072690EW	COPERCHIO	COVER	COUVERTURE	DECKEL	CUBIERTA
36	072690GB	COPERCHIO	COVER	COUVERTURE	DECKEL	CUBIERTA
36	072690GC	COPERCHIO	COVER	COUVERTURE	DECKEL	CUBIERTA
36	072690H1	COPERCHIO	COVER	COUVERTURE	COVER	CUBIERTA
36	072690H3	COPERCHIO	COVER	COUVERTURE	DECKEL	CUBIERTA
36	072690J2	COPERCHIO	COVER	COUVERTURE	DECKEL	CUBIERTA



Main color codes:  J1 - JLG Cream,  J2 - JLG Orange,  C4 - Green

 BASE TORRETTA

 TURRET BASE



 BASE TOURELLE
ARBEITSTURM BASE TORRETTA GIRATORIA 

POS	Codice	 Descrizione	 Description	 Designation	 Benennung	 Descripción
37	072703A3	CARTER DI PROTEZIONE	PROTECTION COVER	CARTER DE DE PROTECTION	CARTER VON SCHUTZ	CARTER DE PROTECCIÓN
37	072703H2	CARTER DI PROTEZIONE	PROTECTION COVER	CARTER DE PROTECTION	CARTER VON SCHUTZ	CARTER DE PROTECCIÓN
38	372846A5	COPERCHIO RADIATORE MOTORE DIESEL	DIESEL ENGINE RADIATOR COVER	BOUCHON DE RADIATEUR MOTEUR DIESEL	KÜHLERVERSCHLUSS DIESEL MOTOR	RADIADOR CAP MOTOR DIESEL
38	372846A9	COPERCHIO RADIATORE MOTORE DIESEL	DIESEL ENGINE RADIATOR COVER	BOUCHON DE RADIATEUR MOTEUR DIESEL	KÜHLERVERSCHLUSS DIESEL MOTOR	RADIADOR CAP MOTOR DIESEL
38	372846AG	COPERCHIO RADIATORE MOTORE DIESEL	DIESEL ENGINE RADIATOR COVER	BOUCHON DE RADIATEUR MOTEUR DIESEL	KÜHLERVERSCHLUSS DIESEL MOTOR	RADIADOR CAP MOTOR DIESEL
38	372846BP	COPERCHIO RADIATORE MOTORE DIESEL	DIESEL ENGINE RADIATOR COVER	MOTEUR DIESEL RADIATEUR CAP	DIESEL MOTOR KÜHLERVERSCHLUSS	MOTOR DIESEL RADIATOR CAP
38	372846CL	COPERCHIO RADIATORE MOTORE DIESEL	DIESEL ENGINE RADIATOR COVER	BOUCHON DE RADIATEUR MOTEUR DIESEL	KÜHLERVERSCHLUSS DIESEL MOTOR	RADIADOR CAP MOTOR DIESEL
38	372846CO	COPERCHIO RADIATORE MOTORE DIESEL	DIESEL ENGINE RADIATOR COVER	BOUCHON DE RADIATEUR MOTEUR DIESEL	KÜHLERVERSCHLUSS DIESEL MOTOR	RADIADOR CAP MOTOR DIESEL
38	372846D5	COPERCHIO RADIATORE MOTORE DIESEL	DIESEL ENGINE RADIATOR COVER	MOTEUR DIESEL RADIATEUR CAP	DIESEL MOTOR KÜHLERVERSCHLUSS	MOTOR DIESEL RADIATOR CAP
38	372846EM	COPERCHIO RADIATORE MOTORE DIESEL	DIESEL ENGINE RADIATOR COVER	MOTEUR DIESEL RADIATEUR CAP	DIESEL MOTOR KÜHLERVERSCHLUSS	MOTOR DIESEL RADIATOR CAP
38	372846H1	COPERCHIO RADIATORE MOTORE DIESEL	DIESEL ENGINE RADIATOR COVER	BOUCHON DE RADIATEUR MOTEUR DIESEL	KÜHLERVERSCHLUSS DIESEL MOTOR	RADIADOR CAP MOTOR DIESEL
38	372846J2	COPERCHIO RADIATORE MOTORE DIESEL	DIESEL ENGINE RADIATOR COVER	BOUCHON DE RADIATEUR MOTEUR DIESEL	KÜHLERVERSCHLUSS DIESEL MOTOR	RADIADOR CAP MOTOR DIESEL

Main color codes:  J1 - JLG Cream,  J2 - JLG Orange,  C4 - Green

 BASE TORRETTA TURRET BASE BASE TOURELLEARBEITSTURM BASE TORRETTA GIRATORIA 





POS	Codice	 Descrizione	 Description	 Designation	 Benennung	 Descripcìon
38	380513A1	COPERCHIO RADIATORE MOTORE KUBOTA LL2010	RADIATOR COVER KUBOTA ENGINE LL2010	COUVERCLE DE RADIATEUR MOTEUR KUBOTA LL2010	KÜHLERDECKEL KUBOTA MOTOR LL2010	TAPA DE RADIADOR MOTOR KUBOTA LL2010
38	380513A3	COPERCHIO RADIATORE MOTORE KUBOTA LL2010	RADIATOR COVER KUBOTA ENGINE LL2010	COUVERCLE DE RADIATEUR MOTEUR KUBOTA LL2010	KÜHLERDECKEL KUBOTA MOTOR LL2010	TAPA DE RADIADOR MOTOR KUBOTA LL2010
38	380513A6	COPERCHIO RADIATORE MOTORE KUBOTA LL2010	RADIATOR COVER KUBOTA ENGINE LL2010	COUVERCLE DE RADIATEUR MOTEUR KUBOTA LL2010	KÜHLERDECKEL KUBOTA MOTOR LL2010	TAPA DE RADIADOR MOTOR KUBOTA LL2010
38	380513A7	COPERCHIO RADIATORE MOTORE KUBOTA LL2010	RADIATOR COVER KUBOTA ENGINE LL2010	COUVERCLE DE RADIATEUR MOTEUR KUBOTA LL2010	KÜHLERDECKEL KUBOTA MOTOR LL2010	TAPA DE RADIADOR MOTOR KUBOTA LL2010
38	380513A8	COPERCHIO RADIATORE MOTORE KUBOTA LL2010	RADIATOR COVER KUBOTA ENGINE LL2010	COUVERCLE DE RADIATEUR MOTEUR KUBOTA LL2010	KÜHLERDECKEL KUBOTA MOTOR LL2010	TAPA DE RADIADOR MOTOR KUBOTA LL2010
38	380513A9	COPERCHIO RADIATORE MOTORE KUBOTA LL2010	RADIATOR COVER KUBOTA ENGINE LL2010	COUVERCLE DE RADIATEUR MOTEUR KUBOTA LL2010	KÜHLERDECKEL KUBOTA MOTOR LL2010	TAPA DE RADIADOR MOTOR KUBOTA LL2010
38	380513B1	COPERCHIO RADIATORE MOTORE KUBOTA LL2010	RADIATOR COVER KUBOTA ENGINE LL2010	COUVERCLE DE RADIATEUR MOTEUR KUBOTA LL2010	KÜHLERDECKEL KUBOTA MOTOR LL2010	TAPA DE RADIADOR MOTOR KUBOTA LL2010
38	380513BP	COPERCHIO RADIATORE MOTORE KUBOTA LL2010	RADIATOR COVER KUBOTA ENGINE LL2010	COUVERCLE DE RADIATEUR MOTEUR KUBOTA LL2010	KÜHLERDECKEL KUBOTA MOTOR LL2010	TAPA DE RADIADOR MOTOR KUBOTA LL2010
38	380513CO	COPERCHIO RADIATORE MOTORE KUBOTA LL2010	RADIATOR COVER KUBOTA ENGINE LL2010	COUVERCLE DE RADIATEUR MOTEUR KUBOTA LL2010	KÜHLERDECKEL KUBOTA MOTOR LL2010	TAPA DE RADIADOR MOTOR KUBOTA LL2010
38	380513D5	COPERCHIO RADIATORE MOTORE KUBOTA LL2010	RADIATOR COVER KUBOTA ENGINE LL2010	COUVERCLE DE RADIATEUR MOTEUR KUBOTA LL2010	KÜHLERDECKEL KUBOTA MOTOR LL2010	TAPA DE RADIADOR MOTOR KUBOTA LL2010
38	380513DI	COPERCHIO RADIATORE MOTORE KUBOTA LL2010	RADIATOR COVER KUBOTA ENGINE LL2010	COUVERCLE DE RADIATEUR MOTEUR KUBOTA LL2010	KÜHLERDECKEL KUBOTA MOTOR LL2010	TAPA DE RADIADOR MOTOR KUBOTA LL2010



Main color codes:  J1 - JLG Cream,  J2 - JLG Orange,  C4 - Green

 BASE TORRETTA





 TURRET BASE



 BASE TOURELLE
ARBEITSTURM BASE TORRETTA GIRATORIA 

POS	Codice	 Descrizione	 Description	 Designation	 Benennung	 Descripción
38	380513EM	COPERCHIO RADIATORE MOTORE KUBOTA LL2010	RADIATOR COVER KUBOTA ENGINE LL2010	COUVERCLE DE RADIATEUR MOTEUR KUBOTA LL2010	KÜHLERDECKEL KUBOTA MOTOR LL2010	TAPA DE RADIADOR MOTOR KUBOTA LL2010
38	380513EW	COPERCHIO RADIATORE MOTORE KUBOTA LL2010	RADIATOR COVER KUBOTA ENGINE LL2010	COUVERCLE DE RADIATEUR MOTEUR KUBOTA LL2010	KÜHLERDECKEL KUBOTA MOTOR LL2010	TAPA DE RADIADOR MOTOR KUBOTA LL2010
38	380513GB	COPERCHIO RADIATORE MOTORE KUBOTA LL2010 RAL6016	RADIATOR COVER KUBOTA ENGINE LL2010 RAL6016	COUVERCLE DE RADIATEUR MOTEUR KUBOTA LL2010 RAL6016	KÜHLERDECKEL KUBOTA MOTOR LL2010 RAL6016	TAPA DE RADIADOR MOTOR KUBOTA LL2010 RAL 6016
38	380513H1	COPERCHIO RADIATORE MOTORE	ENGINE RADIATOR COVER	COUVERCLE DE RADIATEUR DE MOTEUR	MOTORKÜHLERABDE CKUNG	TAPA DEL RADIADOR DE MOTOR
38	380513J2	COPERCHIO RADIATORE MOTORE	ENGINE RADIATOR COVER	COUVERCLE DE RADIATEUR DE MOTEUR	MOTORKÜHLERABDE CKUNG	TAPA DEL RADIADOR DE MOTOR
39	372845A5	PROTEZIONE RIMOVIBILE MOTORE DIESEL	REMOVABLE PROTECTION DIESEL ENGINE	AMOVIBLE PROTECTION MOTEUR DIESEL	REMOVABLE SCHUTZ DIESEL MOTOR	PROTECCIÓN DESMONTABLE MOTOR DIESEL
39	372845A9	PROTEZIONE RIMOVIBILE MOTORE DIESEL	REMOVABLE PROTECTION DIESEL ENGINE	AMOVIBLE PROTECTION MOTEUR DIESEL	REMOVABLE SCHUTZ DIESEL MOTOR	PROTECCIÓN DESMONTABLE MOTOR DIESEL
39	372845AG	PROTEZIONE RIMOVIBILE MOTORE DIESEL	REMOVABLE PROTECTION DIESEL ENGINE	AMOVIBLE PROTECTION MOTEUR DIESEL	REMOVABLE SCHUTZ DIESEL MOTOR	PROTECCIÓN DESMONTABLE MOTOR DIESEL
39	372845BP	PROTEZIONE RIMOVIBILE MOTORE DIESEL	REMOVABLE PROTECTION DIESEL ENGINE	AMOVIBLE PROTECTION MOTEUR DIESEL	REMOVABLE SCHUTZ DIESEL MOTOR	EXTRAIBLE PROTECCION MOTOR DIESEL
39	372845CL	PROTEZIONE RIMOVIBILE MOTORE DIESEL	REMOVABLE PROTECTION DIESEL ENGINE	AMOVIBLE PROTECTION MOTEUR DIESEL	REMOVABLE SCHUTZ DIESEL MOTOR	PROTECCIÓN DESMONTABLE MOTOR DIESEL
39	372845CO	PROTEZIONE RIMOVIBILE MOTORE DIESEL	REMOVABLE PROTECTION DIESEL ENGINE	AMOVIBLE PROTECTION MOTEUR DIESEL	REMOVABLE SCHUTZ DIESEL MOTOR	PROTECCIÓN DESMONTABLE MOTOR DIESEL





Main color codes:  J1 - JLG Cream,  J2 - JLG Orange,  C4 - Green



 BASE TORRETTA TURRET BASE BASE TOURELLEARBEITSTURM BASE TORRETTA GIRATORIA 

POS	Codice	 Descrizione	 Description	 Designation	 Benennung	 Descripción
39	372845D5	PROTEZIONE RIMOVIBILE MOTORE DIESEL	REMOVABLE PROTECTION DIESEL ENGINE	AMOVIBLE PROTECTION MOTEUR DIESEL	REMOVABLE SCHUTZ DIESEL MOTOR	EXTRAIBLE PROTECCION MOTOR DIESEL
39	372845EM	PROTEZIONE RIMOVIBILE MOTORE DIESEL	REMOVABLE PROTECTION DIESEL ENGINE	AMOVIBLE PROTECTION MOTEUR DIESEL	REMOVABLE SCHUTZ DIESEL MOTOR	EXTRAIBLE PROTECCION MOTOR DIESEL
39	372845H1	PROTEZIONE RIMOVIBILE MOTORE DIESEL	REMOVABLE PROTECTION DIESEL ENGINE	AMOVIBLE PROTECTION MOTEUR DIESEL	REMOVABLE SCHUTZ DIESEL MOTOR	PROTECCIÓN DESMONTABLE MOTOR DIESEL
39	372845J2	PROTEZIONE RIMOVIBILE MOTORE DIESEL	REMOVABLE PROTECTION DIESEL ENGINE	AMOVIBLE PROTECTION MOTEUR DIESEL	REMOVABLE SCHUTZ DIESEL MOTOR	PROTECCIÓN DESMONTABLE MOTOR DIESEL
39	380515A1	PROTEZIONE MOBILE SALDATA MOTORE KUBOTA LL2010	SEALED MOBILE PROTECTION KUBOTA ENGINE LL2010	PROTECTION MOBILE SOUDEE MOTEUR KUBOTA LL2010	BEWEGLICHE KUBOTAMOTOR-ABDECKUNG LL2010	PROTECCION MOVIL SOLDADA MOTOR KUBOTA LL2010
39	380515A3	PROTEZIONE MOBILE SALDATA MOTORE KUBOTA LL2010	SEALED MOBILE PROTECTION KUBOTA ENGINE LL2010	PROTECTION MOBILE SOUDEE MOTEUR KUBOTA LL2010	BEWEGLICHE KUBOTAMOTOR-ABDECKUNG LL2010	PROTECCION MOVIL SOLDADA MOTOR KUBOTA LL2010
39	380515A6	PROTEZIONE MOBILE SALDATA MOTORE KUBOTA LL2010	SEALED MOBILE PROTECTION KUBOTA ENGINE LL2010	PROTECTION MOBILE SOUDEE MOTEUR KUBOTA LL2010	BEWEGLICHE KUBOTAMOTOR-ABDECKUNG LL2010	PROTECCION MOVIL SOLDADA MOTOR KUBOTA LL2010
39	380515A7	PROTEZIONE MOBILE SALDATA MOTORE KUBOTA LL2010	SEALED MOBILE PROTECTION KUBOTA ENGINE LL2010	PROTECTION MOBILE SOUDEE MOTEUR KUBOTA LL2010	BEWEGLICHE KUBOTAMOTOR-ABDECKUNG LL2010	PROTECCION MOVIL SOLDADA MOTOR KUBOTA LL2010
39	380515A8	PROTEZIONE MOBILE SALDATA MOTORE KUBOTA LL2010	SEALED MOBILE PROTECTION KUBOTA ENGINE LL2010	PROTECTION MOBILE SOUDEE MOTEUR KUBOTA LL2010	BEWEGLICHE KUBOTAMOTOR-ABDECKUNG LL2010	PROTECCION MOVIL SOLDADA MOTOR KUBOTA LL2010

Main color codes:  J1 - JLG Cream,  J2 - JLG Orange,  C4 - Green

 BASE TORRETTA TURRET BASE BASE TOURELLEARBEITSTURM BASE TORRETTA GIRATORIA 





POS	Codice	 Descrizione	 Description	 Designation	 Benennung	 Descripció
39	380515A9	PROTEZIONE MOBILE SALDATA MOTORE KUBOTA LL2010	SEALED MOBILE PROTECTION KUBOTA ENGINE LL2010	PROTECTION MOBILE SOUDEE MOTEUR KUBOTA LL2010	BEWEGLICHE KUBOTAMOTOR- ABDECKUNG LL2010	PROTECCION MOVIL SOLDADA MOTOR KUBOTA LL2010
39	380515B1	PROTEZIONE MOBILE SALDATA MOTORE KUBOTA LL2010	SEALED MOBILE PROTECTION KUBOTA ENGINE LL2010	PROTECTION MOBILE SOUDEE MOTEUR KUBOTA LL2010	BEWEGLICHE KUBOTAMOTOR- ABDECKUNG LL2010	PROTECCION MOVIL SOLDADA MOTOR KUBOTA LL2010
39	380515BP	PROTEZIONE MOBILE SALDATA MOTORE KUBOTA LL2010	SEALED MOBILE PROTECTION KUBOTA ENGINE LL2010	PROTECTION MOBILE SOUDEE MOTEUR KUBOTA LL2010	BEWEGLICHE KUBOTAMOTOR- ABDECKUNG LL2010	PROTECCION MOVIL SOLDADA MOTOR KUBOTA LL2010
39	380515CO	PROTEZIONE MOBILE SALDATA MOTORE KUBOTA LL2010	SEALED MOBILE PROTECTION KUBOTA ENGINE LL2010	PROTECTION MOBILE SOUDEE MOTEUR KUBOTA LL2010	BEWEGLICHE KUBOTAMOTOR- ABDECKUNG LL2010	PROTECCION MOVIL SOLDADA MOTOR KUBOTA LL2010
39	380515D5	PROTEZIONE MOBILE SALDATA MOTORE KUBOTA LL2010	SEALED MOBILE PROTECTION KUBOTA ENGINE LL2010	PROTECTION MOBILE SOUDEE MOTEUR KUBOTA LL2010	BEWEGLICHE KUBOTAMOTOR- ABDECKUNG LL2010	PROTECCION MOVIL SOLDADA MOTOR KUBOTA LL2010
39	380515DI	PROTEZIONE MOBILE SALDATA MOTORE KUBOTA LL2010	SEALED MOBILE PROTECTION KUBOTA ENGINE LL2010	PROTECTION MOBILE SOUDEE MOTEUR KUBOTA LL2010	BEWEGLICHE KUBOTAMOTOR- ABDECKUNG LL2010	PROTECCION MOVIL SOLDADA MOTOR KUBOTA LL2010
39	380515EM	PROTEZIONE MOBILE SALDATA MOTORE KUBOTA LL2010	SEALED MOBILE PROTECTION KUBOTA ENGINE LL2010	PROTECTION MOBILE SOUDEE MOTEUR KUBOTA LL2010	BEWEGLICHE KUBOTAMOTOR- ABDECKUNG LL2010	PROTECCION MOVIL SOLDADA MOTOR KUBOTA LL2010
39	380515EW	PROTEZIONE MOBILE SALDATA MOTORE KUBOTA LL2010	SEALED MOBILE PROTECTION KUBOTA ENGINE LL2010	PROTECTION MOBILE SOUDEE MOTEUR KUBOTA LL2010	BEWEGLICHE KUBOTAMOTOR- ABDECKUNG LL2010	PROTECCION MOVIL SOLDADA MOTOR KUBOTA LL2010



Main color codes:  J1 - JLG Cream,  J2 - JLG Orange,  C4 - Green

 BASE TORRETTA

 TURRET BASE

 BASE TOURELLE
ARBEITSTURM BASE TORRETTA GIRATORIA 





POS	Codice	 Descrizione	 Description	 Designation	 Benennung	 Descripción
39	380515GB	PROTEZIONE MOBILE SALDATA MOTORE KUBOTA LL2010 RAL6016	SEALED MOBILE PROTECTION KUBOTA ENGINE LL2010 RAL6016	PROTECTION MOBILE SOUDEE MOTEUR KUBOTA LL2010 RAL6016	BEWEGLICHE KUBOTAMOTOR- ABDECKUNG LL2010 RAL 6016	PROTECCION MOVIL SOLDADA MOTOR KUBOTA LL2010 RAL6016
39	380515H1	PROTEZIONE MOBILE MOTORE	ENGINE PROTECTION	SUPPORT MOTEUR	MOTOR HALTERUNG	SOPORTE MOTOR
39	380515J2	PROTEZIONE MOBILE MOTORE	ENGINE PROTECTION	SUPPORT MOTEUR	MOTOR HALTERUNG	SOPORTE MOTOR
40	084477D2	INDICE ALLINEAMENTO FISSO - SPEDIRE SEMPRE CON 084476D2	ALIGNMENT INDICATOR - SHIP ALWAYS WITH 084476D2	INDEX D'ALIGNEMENT FIXE - TOUJOURS LIVRER AVEC 084476D2	FESTE AUSRICHTUNGSMAR- KIERUNG - IMMER MIT 084476D2 LIEFERN	ÍNDICE DE ALINEACIÓN FIJO - OFRECER SIEMPRE CON 084476D2
41	04834500	CLAXON 12V	HORN	KLAXON	HORN	BOCINA
42	06550100	VITE M16X20 TESTA RIBASSATA	REDUCED HEAD SCREW M16X20	BAISSE VIS À TÊTE M16X20	GESENKTEN KOPF SCREW M16X20	BAJADO TORNILLO CABEZA M16X20
43	180507A1	COFANO FISSO	HOOD	COFFRE	MOTORHAUBE	CAPÓ
43	180507A3	COFANO FISSO	HOOD	CAPOT	MOTORHAUBE	CAPÓ
43	180507A6	COFANO FISSO	HOOD	COFFRE	MOTORHAUBE	CAPÓ
43	180507A7	COFANO FISSO	FIXED	CAPOT	MOTORHAUBE	CAPÓ
43	180507A8	COFANO FISSO	HOOD	COFFRE	MOTORHAUBE	CAPÓ
43	180507A9	COFANO FISSO	HOOD	COFFRE	MOTORHAUBE	CAPÓ
43	180507B1	COFANO FISSO	HOOD	COFFRE	MOTORHAUBE	CAPÓ
43	180507BP	COFANO FISSO	HOOD	COFFRE	MOTORHAUBE	CAPÓ
43	180507CO	COFANO FISSO	HOOD	CAPOT	MOTORHAUBE	CAPÓ
43	180507D5	COFANO FISSO	HOOD	COFFRE	MOTORHAUBE	CAPÓ
43	180507DI	COFANO FISSO	HOOD	COFFRE	MOTORHAUBE	CAPÓ
43	180507EM	COFANO FISSO	HOOD	COFFRE	MOTORHAUBE	CAPÓ
43	180507EW	COFANO FISSO	HOOD	COFFRE	MOTORHAUBE	CAPÓ
43	180507GB	COFANO FISSO	HOOD	COFFRE	MOTORHAUBE	CAPÓ
43	180507H1	COFANO FISSO	FIXED HOOD	BONNET FIXE	FIXE HAUBE	CUBIERTA FIJA
43	180507J2	COFANO FISSO	FIXED HOOD	BONNET FIXE	FIXE HAUBE	CUBIERTA FIJA



Main color codes:  J1 - JLG Cream,  J2 - JLG Orange,  C4 - Green

 BASE TORRETTA





 TURRET BASE



 BASE TOURELLE
ARBEITSTURM BASE TORRETTA GIRATORIA 



POS	Codice	 Descrizione	 Description	 Designation	 Benennung	 Descripción
43	372844A5	PROTEZIONE FISSA MOTORE DIESEL	DIESEL ENGINE PROTECTION	DIESEL PROTECTION MOTEUR FIXE	DIESEL MOTOR SCHUTZ FIXED	PROTECCIÓN DEL MOTOR DIESEL FIJO
43	372844A9	PROTEZIONE FISSA MOTORE DIESEL	DIESEL ENGINE PROTECTION	DIESEL PROTECTION MOTEUR FIXE	DIESEL MOTOR SCHUTZ FIXED	PROTECCIÓN DEL MOTOR DIESEL FIJO
43	372844AG	PROTEZIONE FISSA MOTORE DIESEL	DIESEL ENGINE PROTECTION	DIESEL PROTECTION MOTEUR FIXE	DIESEL MOTOR SCHUTZ FIXED	PROTECCIÓN DEL MOTOR DIESEL FIJO
43	372844BP	PROTEZIONE FISSA MOTORE DIESEL	DIESEL ENGINE PROTECTION	DIESEL PROTECTION MOTEUR FIXE	DIESEL MOTOR SCHUTZ FIXED	DIESEL ENGINE SKYDD FAST
43	372844CL	PROTEZIONE FISSA MOTORE DIESEL	DIESEL ENGINE PROTECTION	DIESEL PROTECTION MOTEUR FIXE	DIESEL MOTOR SCHUTZ FIXED	PROTECCIÓN DEL MOTOR DIESEL FIJO
43	372844CO	PROTEZIONE FISSA MOTORE DIESEL	DIESEL ENGINE PROTECTION	DIESEL PROTECTION MOTEUR FIXE	DIESEL MOTOR SCHUTZ FIXED	PROTECCIÓN DEL MOTOR DIESEL FIJO
43	372844D5	PROTEZIONE FISSA MOTORE DIESEL	DIESEL ENGINE PROTECTION	DIESEL PROTECTION MOTEUR FIXE	DIESEL MOTOR SCHUTZ FIXED	PROTECCIÓN DEL MOTOR DIESEL FIJO
43	372844EM	PROTEZIONE FISSA MOTORE DIESEL	DIESEL ENGINE PROTECTION	DIESEL PROTECTION MOTEUR FIXE	DIESEL MOTOR SCHUTZ FIXED	PROTECCIÓN DEL MOTOR DIESEL FIJO
43	372844H1	PROTEZIONE FISSA MOTORE DIESEL	DIESEL ENGINE PROTECTION	DIESEL PROTECTION MOTEUR FIXE	DIESEL MOTOR SCHUTZ FIXED	PROTECCIÓN DEL MOTOR DIESEL FIJO
43	372844J2	PROTEZIONE FISSA MOTORE DIESEL	DIESEL ENGINE PROTECTION	DIESEL PROTECTION MOTEUR FIXE	DIESEL MOTOR SCHUTZ FIXED	PROTECCIÓN DEL MOTOR DIESEL FIJO
44	05442500	RISCONTRO	FASTENER LOCATOR	PLAQUE POUR AGRAFAGE	ANSCHLAG	GANCHO
45	05442600	CHIUSURA A GANCIO	HOOK FASTENING	FERMETURE À CROCHET	HAKENVERSCHLUSS	GANCHO DE CIERRE
46	173126BP	SERBATOIO GASOLIO	DIESEL TANK	RÉSERVOIR DE GASOIL	DIESELTANK	DEPÓSITO DE GASÓLEO
46	173126D5	SERBATOIO GASOLIO	DIESEL TANK	RÉSERVOIR DE GASOIL	DIESELTANK	DEPÓSITO DE GASÓLEO
46	173126EM	SERBATOIO GASOLIO	DIESEL TANK	RÉSERVOIR DE GASOIL	DIESELTANK	DEPÓSITO DE GASÓLEO
46	173126H3	SERBATOIO GASOLIO	DIESEL TANK	RÉSERVOIR DE GASOIL	DIESELTANK	DEPÓSITO DE GASÓLEO
46	173126J0	SERBATOIO GASOLIO	DIESEL TANK	RÉSERVOIR DE GASOIL	DIESELTANK	DEPÓSITO DE GASÓLEO

Main color codes:  J1 - JLG Cream,  J2 - JLG Orange,  C4 - Green



 BASE TORRETTA TURRET BASE BASE TOURELLEARBEITSTURM BASE TORRETA GIRATORIA 



POS	Codice	 Descrizione	 Description	 Designation	 Benennung	 Descripción
47	25731300	TAPPO	CAP	BOUCHON	VERSCHLUSS	TAPÓN
48	07313100	LIVELLO GASOLIO	GAS OIL LEVEL	NIVEAU GASOIL	KRAFTSTOFFSTAND	NIVEL GASÓLEO
49	05656400	CHIAVE TAPPO DIESEL	KEY DIESEL CAP	CLÉ	SCHLÜSSEL	LLAVE
50	17496000	ASSIEME SALDATO CASSONE LL2010, X20JP CON COPERCHI	ASSEMBLY BOX WELDED FOR LL2010, X20JP, X600AJ WITH COVER	ENSEMBLE	MULDE	CAJON

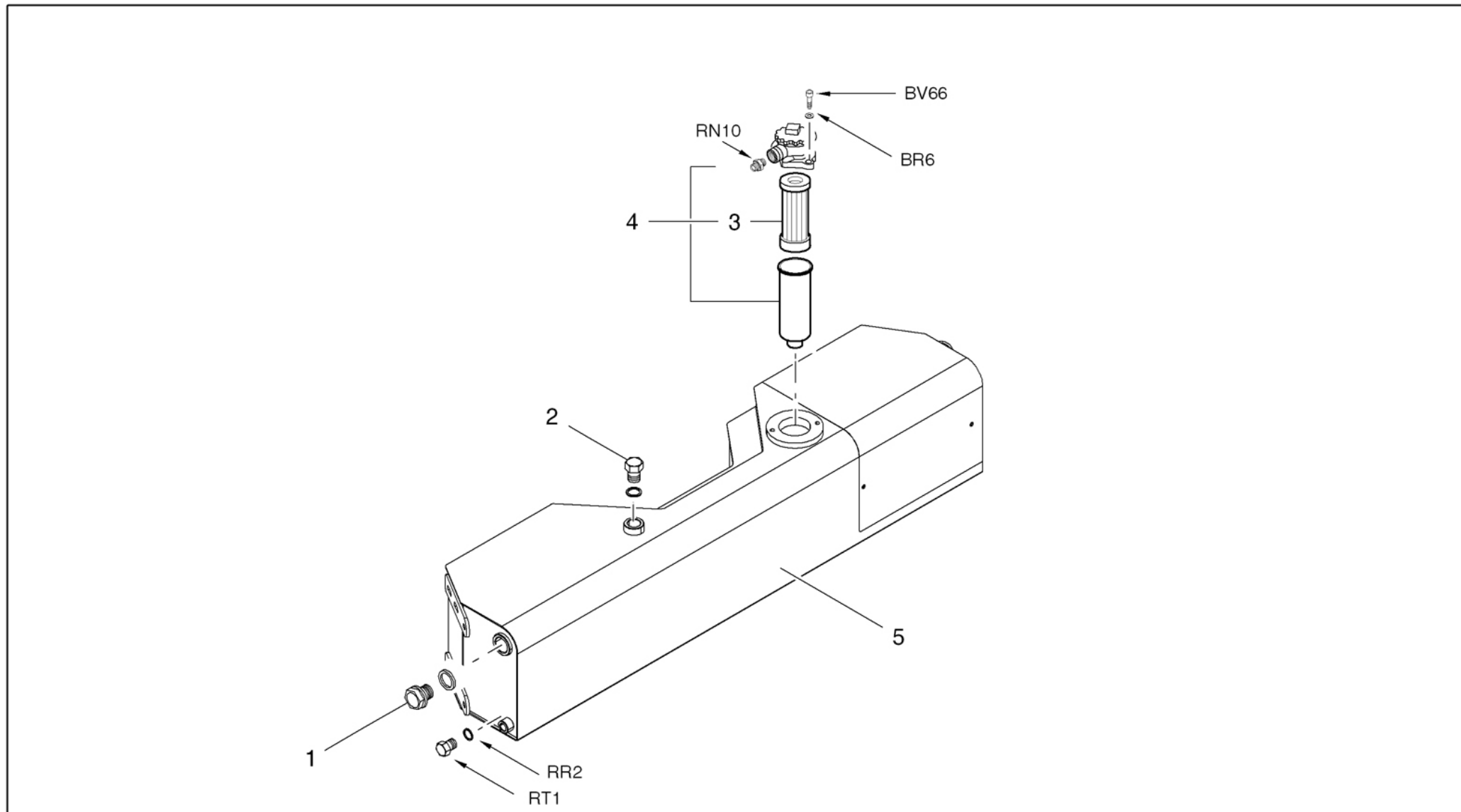

-  SERBATOIO OLIO
-  OIL TANK
-  RÉSERVOIR D'HUILE

ÖLTANK 
DEPÓSITO DE ACEITE 









Main color codes:  J1 - JLG Cream,  J2 - JLG Orange,  C4 - Green



 SERBATOIO OLIO
 OIL TANK
 RÉSERVOIR D'HUILE

ÖLTANK 
 DEPÓSITO DE ACEITE 



POS	Codice	 Descrizione	 Description	 Designation	 Benennung	 Descripción
1	05061800	LIVELLO OLIO	OIL LEVEL	NIVEAU HUILE	ÖLSTAND	NIVEL ACEITE
2	05611800	TAPPO OLIO	OIL PLUG	BOUCHON D'HUILE	ÖLDECKEL	TAPÓN ACEITE
3	05120200	CARTUCCIA FILTRO OLIO IDRAULICO	HYDRAULIC FILTER	CARTOUCHE FILTRE À HUILE	ÖLFILTEREINSATZ	CARTUCHO FILTRO ACEITE
4	15120100	FILTRO OLIO IDRAULICO COMPLETO	COMPLETE HYDRAULIC OIL FILTER	FILTRE À HUILE	HYDARULIKÖLFILTE R	FILTRO ACEITE HIDRÁULICO
5	172661A1	SERBATOIO OLIO COMPLETO	OIL TANK COMPLETE	SERBATOIO OLIO COMPLETO	OIL TANK COMPLETE	ACEITE COMPLETA
5	172661A3	SERBATOIO OLIO COMPLETO	OIL TANK COMPLETE	HUILE COMPLETE	OIL TANK COMPLETE	ACEITE COMPLETA
5	172661A5	SERBATOIO OLIO COMPLETO	OIL TANK COMPLETE	HUILE COMPLET	OIL TANK COMPLETE	ACEITE COMPLETA
5	172661A6	SERBATOIO OLIO COMPLETO	OIL TANK COMPLETE	HUILE COMPLETE	OIL TANK COMPLETE	ACEITE COMPLETA
5	172661A7	SERBATOIO OLIO COMPLETO	OIL TANK COMPLETE	SERBATOIO OLIO COMPLETO	OIL TANK COMPLETE	ACEITE COMPLETA
5	172661A8	SERBATOIO OLIO COMPLETO	OIL TANK COMPLETE	SERBATOIO OLIO COMPLETO	OIL TANK COMPLETE	ACEITE COMPLETA
5	172661A9	SERBATOIO OLIO COMPLETO	OIL TANK COMPLETE	HUILE COMPLETE	OIL TANK COMPLETE	ACEITE COMPLETA
5	172661AG	SERBATOIO OLIO COMPLETO LL2010	OIL TANK COMPLETE	HUILE COMPLETE	OIL TANK COMPLETE	ACEITE COMPLETA
5	172661B1	SERBATOIO OLIO COMPLETO	OIL TANK COMPLETE	HUILE COMPLETE	OIL TANK COMPLETE	ACEITE COMPLETA
5	172661BA	SERBATOIO OLIO COMPLETO	OIL TANK COMPLETE	HUILE COMPLETE	OIL TANK COMPLETE	ACEITE COMPLETA
5	172661BC	SERBATOIO OLIO COMPLETO	OIL TANK COMPLETE	HUILE COMPLETE	OIL TANK COMPLETE	ACEITE COMPLETA
5	172661BP	SERBATOIO OLIO COMPLETO	OIL TANK COMPLETE	HUILE COMPLETE	OIL TANK COMPLETE	ACEITE COMPLETA
5	172661C4	SERBATOIO OLIO COMPLETO	OIL TANK COMPLETE	SERBATOIO OLIO COMPLETO	OIL TANK COMPLETE	ACEITE COMPLETA



Main color codes:  J1 - JLG Cream,  J2 - JLG Orange,  C4 - Green



 SERBATOIO OLIO
 OIL TANK
 RÉSERVOIR D'HUILE

ÖLTANK 
 DEPÓSITO DE ACEITE 



POS	Codice	 Descrizione	 Description	 Designation	 Benennung	 Descripción
5	172661CL	SERBATOIO OLIO COMPLETO LL2010	OIL TANK COMPLETE	HUILE COMPLETE	OIL TANK COMPLETE	ACEITE COMPLETA
5	172661CO	SERBATOIO OLIO COMPLETO	OIL TANK COMPLETE	HUILE COMPLETE	OIL TANK COMPLET	ACEITE COMPLETA
5	172661D5	SERBATOIO OLIO COMPLETO	OIL TANK COMPLETE	HUILE COMPLETE	OIL TANK COMPLETE	ACEITE COMPLETA
5	172661DI	SERBATOIO OLIO COMPLETO	OIL TANK COMPLETE	HUILE COMPLETE	OIL TANK COMPLETE	ACEITE COMPLETA
5	172661EM	SERBATOIO OLIO COMPLETO	OIL TANK COMPLETE	HUILE COMPLETE	OIL TANK COMPLETE	ACEITE COMPLETA
5	172661EW	SERBATOIO OLIO COMPLETO	OIL TANK COMPLETE	HUILE COMPLETE	OIL TANK COMPLET	ACEITE COMPLETA
5	172661GB	SERBATOIO OLIO COMPLETO	OIL TANK COMPLETE	HUILE COMPLETE	OIL TANK COMPLETE	ACEITE COMPLETA
5	172661GC	SERBATOIO OLIO COMPLETO	OIL TANK COMPLETE	HUILE COMPLETE	OIL TANK COMPLETE	ACEITE COMPLETA
5	172661H1	SERBATOIO OLIO COMPLETO	OIL TANK COMPLETE	HUILE COMPLETE	OIL TANK COMPLETE	ACEITE COMPLETA
5	172661H3	SERBATOIO OLIO COMPLETO	OIL TANK COMPLETE	SERBATOIO OLIO COMPLETO	OIL TANK COMPLETE	ACEITE COMPLETA
5	172661J2	SERBATOIO OLIO COMPLETO LL2010	OIL TANK COMPLETE	HUILE COMPLETE	OIL TANK COMPLETE	ACEITE COMPLETA

Main color codes:  J1 - JLG Cream,  J2 - JLG Orange,  C4 - Green

-  PRIMO BRACCIO
-  FIRST ARM
-  PREMIER BRAS

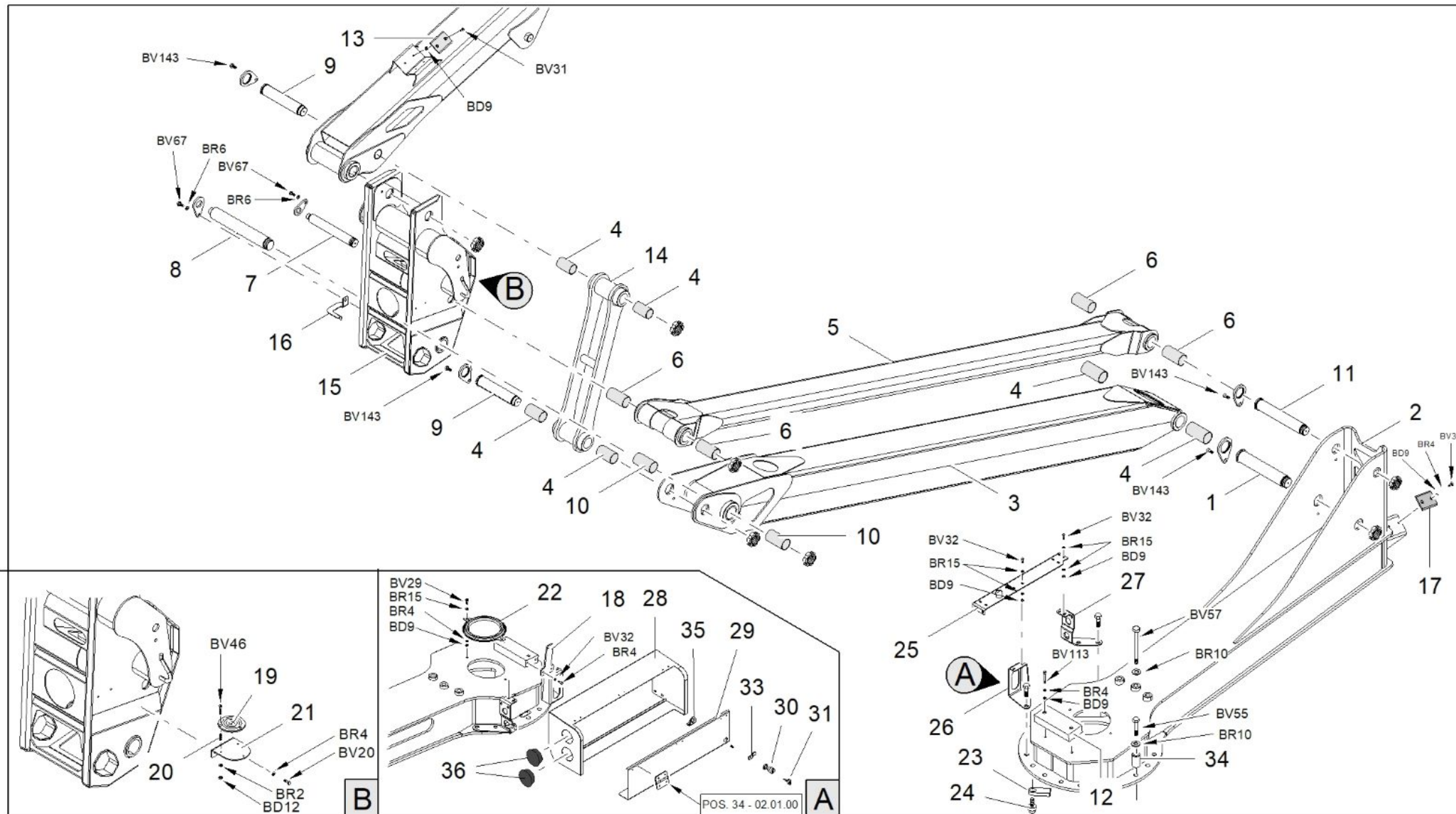
ERSTER AUSLEGERARM 
PRIMO BRAZO 











Main color codes:  J1 - JLG Cream,  J2 - JLG Orange,  C4 - Green

 PRIMO BRACCIO

 FIRST ARM

 PREMIER BRAS
ERSTER AUSLEGERARM PRIMO BRAZO 





POS	Codice	 Descrizione	 Description	 Designation	 Benennung	 Descripción
1	07270500	SPINA	PIN	CHEVILLE	STIF	CLAVIJA
2	372623A1	SUPPORTO BRACCI	SUPPORT MAIN BOOM	BRAZOS DE SOPORTE	TRAGARME	LOS BRAZOS DE SOPORTE
2	372623A3	SUPPORTO BRACCI	SUPPORT MAIN BOOM	BRAS DE SOUTIEN	TRAGARME	LOS BRAZOS DE SOPORTE
2	372623A5	SUPPORTO BRACCI	SUPPORT MAIN BOOM	BRAS DE SOUTIEN	TRAGARME	LOS BRAZOS DE SOPORTE
2	372623A6	SUPPORTO BRACCI	SUPPORT MAIN BOOM	BRAS DE SOUTIEN	TRAGARME	LOS BRAZOS DE SOPORTE
2	372623A7	SUPPORTO BRACCI	SUPPORT MAIN BOOM	BRAZOS DE SOPORTE	TRAGARME	LOS BRAZOS DE SOPORTE
2	372623A8	SUPPORTO BRACCI	SUPPORT MAIN BOOM	BRAZOS DE SOPORTE	TRAGARME	LOS BRAZOS DE SOPORTE
2	372623A9	SUPPORTO BRACCI	SUPPORT MAIN BOOM	BRAS DE SOUTIEN	TRAGARME	LOS BRAZOS DE SOPORTE
2	372623AG	SUPPORTO BRACCI	SUPPORT MAIN BOOM	BRAS DE SOUTIEN	TRAGARME	LOS BRAZOS DE SOPORTE
2	372623B1	SUPPORTO BRACCI	SUPPORT MAIN BOOM	BRAS DE SOUTIEN	TRAGARME	LOS BRAZOS DE SOPORTE
2	372623BA	SUPPORTO BRACCI	SUPPORT MAIN BOO	BRAS DE SOUTIEN	TRAGARM	LOS BRAZOS DE SOPORTE
2	372623BC	SUPPORTO BRACCI	SUPPORT MAIN BOOM	BRAS DE SOUTIEN	TRAGARME	LOS BRAZOS DE SOPORTE
2	372623BP	SUPPORTO BRACCI	SUPPORT MAIN BOOM	BRAZOS DE SOPORTE	TRAGARME	LOS BRAZOS DE SOPORTE
2	372623C4	SUPPORTO BRACCI	SUPPORT MAIN BOOM	BRAS DE SOUTIEN	TRAGARME	LOS BRAZOS DE SOPORTE
2	372623CL	SUPPORTO BRACCI	SUPPORT MAIN BOOM	BRAS DE SOUTIEN	TRAGARME	LOS BRAZOS DE SOPORTE
2	372623CO	SUPPORTO BRACCI	SUPPORT MAIN BOOM	BRAS DE SOUTIEN	TRAGARME	LOS BRAZOS DE SOPORTE
2	372623D5	SUPPORTO BRACCI	SUPPORT MAIN BOOM	BRAZOS DE SOPORTE	TRAGARME	LOS BRAZOS DE SOPORTE



Main color codes:  J1 - JLG Cream,  J2 - JLG Orange,  C4 - Green

 PRIMO BRACCIO

 FIRST ARM

 PREMIER BRAS
ERSTER AUSLEGERARM PRIMO BRAZO 





POS	Codice	 Descrizione	 Description	 Designation	 Benennung	 Descripción
2	372623DI	SUPPORTO BRACCI	SUPPORT MAIN BOOM	BRAS DE SOUTIEN	TRAGARME	LOS BRAZOS DE SOPORTE
2	372623FX	SUPPORTO BRACCI	SUPPORT MAIN BOOM	BRAZOS DE SOPORTE	TRAGARME	LOS BRAZOS DE SOPORTE
2	372623GB	SUPPORTO BRACCI	SUPPORT MAIN BOOM	BRAS DE SOUTIEN	TRAGARME	LOS BRAZOS DE SOPORTE
2	372623H1	SUPPORTO BRACCI	SUPPORT MAIN BOOM	BRAS DE SOUTIEN	TRAGARME	LOS BRAZOS DE SOPORTE
2	372623H3	SUPPORTO BRACCI	SUPPORT MAIN BOOM	BRAS DE SOUTIEN	TRAGARME	LOS BRAZOS DE SOPORTE
2	372623J1	SUPPORTO BRACCI	SUPPORT MAIN BOOM	BRAS DE SOUTIEN	TRAGARME	LOS BRAZOS DE SOPORTE
3	172613A1	PRIMO BRACCIO	FIRST ARM	PREMIER BRAS	ERSTER AUSLEGERARM	PRIMO BRAZO
3	172613A3	PRIMO BRACCIO	FIRST ARM	PREMIER BRAS	ERSTER AUSLEGERARM	PRIMO BRAZO
3	172613A5	PRIMO BRACCIO	FIRST ARM	PREMIER BRAS	ERSTER AUSLEGERARM	PRIMO BRAZO
3	172613A6	PRIMO BRACCIO	FIRST ARM	PREMIER BRAS	ERSTER AUSLEGERARM	PRIMO BRAZO
3	172613A7	PRIMO BRACCIO	FIRST ARM	PREMIER BRAS	ERSTER AUSLEGERARM	PRIMO BRAZO
3	172613A8	PRIMO BRACCIO	FIRST ARM	PREMIER BRAS	ERSTER AUSLEGERARM	PRIMO BRAZO
3	172613A9	PRIMO BRACCIO	FIRST ARM	PREMIER BRAS	ERSTER AUSLEGERARM	PRIMO BRAZO
3	172613AG	PRIMO BRACCIO	FIRST ARM	PREMIER BRAS	ERSTER AUSLEGERARM	PRIMO BRAZO
3	172613B1	PRIMO BRACCIO	FIRST ARM	PREMIER BRAS	ERSTER AUSLEGERARM	PRIMO BRAZO
3	172613BA	PRIMO BRACCIO	FIRST ARM	PREMIER BRAS	ERSTER AUSLEGERARM	PRIMO BRAZO
3	172613BC	PRIMO BRACCIO	FIRST ARM	PREMIER BRAS	ERSTER AUSLEGERARM	PRIMO BRAZO



Main color codes:  J1 - JLG Cream,  J2 - JLG Orange,  C4 - Green

 PRIMO BRACCIO

 FIRST ARM

 PREMIER BRAS
ERSTER AUSLEGERARM PRIMO BRAZO 





POS	Codice	 Descrizione	 Description	 Designation	 Benennung	 Descripción
3	172613BP	PRIMO BRACCIO	FIRST ARM	PREMIER BRAS	ERSTER AUSLEGERARM	PRIMO BRAZO
3	172613C4	PRIMO BRACCIO	FIRST ARM	PREMIER BRAS	ERSTER AUSLEGERARM	PRIMO BRAZO
3	172613CL	PRIMO BRACCIO	FIRST ARM	PREMIER BRAS	ERSTER AUSLEGERARM	PRIMO BRAZO
3	172613CO	PRIMO BRACCIO	FIRST ARM	PREMIER BRAS	ERSTER AUSLEGERARM	PRIMO BRAZO
3	172613D5	PRIMO BRACCIO	FIRST ARM	PREMIER BRAS	ERSTER AUSLEGERARM	PRIMO BRAZO
3	172613DI	PRIMO BRACCIO	FIRST ARM	PREMIER BRAS	ERSTER AUSLEGERARM	PRIMO BRAZO
3	172613FX	PRIMO BRACCIO	FIRST ARM	PREMIER BRAS	ERSTER AUSLEGERARM	PRIMO BRAZO
3	172613GB	PRIMO BRACCIO	FIRST ARM	PREMIER BRAS	ERSTER AUSLEGERARM	PRIMO BRAZO
3	172613H1	PRIMO BRACCIO	FIRST ARM	PREMIER BRAS	ERSTER AUSLEGERARM	PRIMO BRAZO
3	172613H3	PRIMO BRACCIO	FIRST ARM	PREMIER BRAS	ERSTER AUSLEGERARM	PRIMO BRAZO
3	172613J1	PRIMO BRACCIO	FIRST ARM	PREMIER BRAS	ERSTER AUSLEGERARM	PRIMO BRAZO
4	07256800	BOCCOLA	BUSH	DOUILLE	BUCHSE	CASQUILLO
5	172635A1	TIRANTE PRIMO BRACCIO	FIRST ARM TIE ROD	TIRANT	TURMGESTÄNGE	TIRANTE
5	172635A3	TIRANTE	TIE ROD	TIRANT	TURMGESTÄNGE	TIRANTE
5	172635A5	TIRANTE	TIE ROD	TIRANT	TURMGESTÄNGE	TIRANTE
5	172635A6	TIRANTE	TIE ROD	TIRANT	TURMGESTÄNGE	TIRANTE
5	172635A7	TIRANTE	TIE ROD	TIRANT	TURMGESTÄNGE	TIRANTE
5	172635A8	TIRANTE PRIMO BRACCIO	FIRST ARM TIE ROD	TIRANT	TURMGESTÄNGE	TIRANTE
5	172635A9	TIRANTE	TIE ROD	TIRANT	TURMGESTÄNGE	TIRANTE
5	172635AG	TIRANTE PRIMO BRACCIO	FIRST ARM TIE ROD	TIRANT	TURMGESTÄNGE	TIRANTE



Main color codes:  J1 - JLG Cream,  J2 - JLG Orange,  C4 - Green

 PRIMO BRACCIO

 FIRST ARM

 PREMIER BRAS
ERSTER AUSLEGERARM PRIMO BRAZO 

POS	Codice	 Descrizione	 Description	 Designation	 Benennung	 Descripción
5	172635B1	TIRANTE	TIE ROD	TIRANT	TURMGESTÄNGE	TIRANTE
5	172635BA	TIRANTE	TIE ROD	TIRANT	TURMGESTÄNGE	TIRANTE
5	172635BC	TIRANTE	TIE ROD	TIRANT	TURMGESTÄNGE	TIRANTE
5	172635BP	TIRANTE	TIE ROD	TIRANT	TURMGESTÄNGE	TIRANTE
5	172635C4	TIRANTE	TIE ROD	TIRANT	TURMGESTÄNGE	TIRANTE
5	172635CL	TIRANTE PRIMO BRACCIO	FIRST ARM TIE ROD	TIRANT	TURMGESTÄNGE	TIRANTE
5	172635CO	TIRANTE	TIE ROD	TIRANT	TURMGESTÄNGE	TIRANTE
5	172635D5	TIRANTE PRIMO BRACCIO	FIRST ARM TIE ROD	TIRANT	TURMGESTÄNGE	TIRANTE
5	172635DI	TIRANTE	TIE ROD	TIRANT	TURMGESTÄNGE	TIRANTE
5	172635FX	TIRANTE	TIE ROD	TIRANT	TURMGESTÄNGE	TIRANTE
5	172635GB	TIRANTE	TIE ROD	TIRANT	TURMGESTÄNGE	TIRANTE
5	172635H1	TIRANTE PRIMO BRACCIO	FIRST ARM TIE ROD	TIRANT	TURMGESTÄNGE	TIRANTE
5	172635H3	TIRANTE	TIE ROD	TIRANT	TURMGESTÄNGE	TIRANTE
5	172635J1	TIRANTE PRIMO BRACCIO	FIRST ARM TIE ROD	TIRANT	TURMGESTÄNGE	TIRANTE
6	06434200	BOCCOLA	BUSH	DOUILLE	BUCHSE	CASQUILLO
7	07271000	SPINA	PIN	CHEVILLE	STIF	CLAVIJA
8	07270900	SPINA	PIN	CHEVILLE	STIF	CLAVIJA
9	07271400	SPINA	PIN	CHEVILLE	STIF	CLAVIJA
10	07262200	BOCCOLA	BUSH	DOUILLE	BUCHSE	CASQUILLO
11	07270600	SPINA	PIN	CHEVILLE	STIF	CLAVIJA
12	07314000	TAMPONE APPOGGIO PRIMO BRACCIO	BUFFER SUPPORT FIRST ARM	TAMPON DE SUPPORT PREMIER BRAS	PUFFER ARMHALTERUNG	TAMPÓN PRIMER BRAZO
13	07314500	TAMPONE APPOGGIO TERZO BRACCIO	THIRD ARM PAD SUPPORT	TAMPON	PUFFER	TAMPÓN
14	172632A1	BIELLA PRIMO-SECONDO BRACCIO COMPLETA	TIEROD FIRST-SECOND BOOMS	TIGE PREMIER - DEUXIÈME ARM PLEIN	ROD ERSTE - ZWEITE ARM VOLL	BARRA PRIMERA - SEGUNDO ARM COMPLETO



Main color codes:  J1 - JLG Cream,  J2 - JLG Orange,  C4 - Green

 PRIMO BRACCIO

 FIRST ARM

 PREMIER BRAS
ERSTER AUSLEGERARM PRIMO BRAZO 

POS	Codice	 Descrizione	 Description	 Designation	 Benennung	 Descripción
14	172632A3	BIELLA PRIMO- SECONDO BRACCIO COMPLETA	TIEROD FIRST- SECOND BOOMS	TIGE PREMIER - DEUXIÈME ARM PLEIN	ROD ERSTE - ZWEITE ARM VOLL	BARRA PRIMERA - SEGUNDO ARM COMPLETO
14	172632A5	BIELLA PRIMO- SECONDO BRACCIO COMPLETA	TIEROD FIRST- SECOND BOOMS	TIGE PREMIER DEUXIEME ARM PLEIN	ROD ERSTE ZWEITE- ARM VOLL	BARRA PRIMERA SEGUNDA ARM COMPLETO
14	172632A6	BIELLA PRIMO- SECONDO BRACCIO COMPLETA	TIEROD FIRST- SECOND BOOMS	TIGE PREMIER - DEUXIÈME ARM PLEIN	ROD ERSTE - ZWEITE ARM VOLL	BARRA PRIMERA - SEGUNDO ARM COMPLETO
14	172632A7	BIELLA PRIMO- SECONDO BRACCIO COMPLETA	TIEROD FIRST- SECOND BOOMS	TIGE PREMIER DEUXIEME ARM PLEIN	ROD ERSTE ZWEITE- ARM VOLL	BARRA PRIMERA SEGUNDA ARM COMPLETO
14	172632A8	BIELLA PRIMO- SECONDO BRACCIO COMPLETA	TIEROD FIRST- SECOND BOOMS	TIGE PREMIER - DEUXIÈME ARM PLEIN	ROD ERSTE - ZWEITE ARM VOLL	BARRA PRIMERA - SEGUNDO ARM COMPLETO
14	172632A9	BIELLA PRIMO- SECONDO BRACCIO COMPLETA	TIEROD FIRST- SECOND BOOMS	TIGE PREMIER DEUXIEME ARM PLEIN	ROD ERSTE ZWEITE- ARM VOLL	BARRA PRIMERA SEGUNDA ARM COMPLETO
14	172632AG	BIELLA PRIMO- SECONDO BRACCIO COMPLETA	TIEROD FIRST- SECOND BOOMS	ROD PREMIERS DEUXIÈME BRAS COMPLET	ROD ERSTE ZWEITE- VOLL ARM	BARRA DE PRIMER SEGUNDO BRAZO COMPLETO
14	172632B1	BIELLA PRIMO- SECONDO BRACCIO COMPLETA	TIEROD FIRST- SECOND BOOMS	TIGE PREMIER - DEUXIÈME ARM PLEIN	ROD ERSTE - ZWEITE ARM VOLL	BARRA PRIMERA - SEGUNDO ARM COMPLETO
14	172632BA	BIELLA PRIMO- SECONDO BRACCIO COMPLETA	TIEROD FIRST- SECOND BOOMS	TIGE PREMIER - DEUXIÈME ARM PLEIN	ROD ERSTE - ZWEITE ARM VOLL	BARRA PRIMERA - SEGUNDO ARM COMPLETO
14	172632BC	BIELLA PRIMO- SECONDO BRACCIO COMPLETA	TIEROD FIRST- SECOND BOOMS	TIGE PREMIER - DEUXIÈME ARM PLEIN	ROD ERSTE - ZWEITE ARM VOLL	BARRA PRIMERA - SEGUNDO ARM COMPLETO
14	172632BP	BIELLA PRIMO- SECONDO BRACCIO COMPLETA	TIEROD FIRST- SECOND BOOMS	TIGE PREMIER DEUXIEME ARM PLEIN	ROD ERSTE ZWEITE- ARM VOLL	BARRA PRIMERA SEGUNDA ARM COMPLETO



Main color codes:  J1 - JLG Cream,  J2 - JLG Orange,  C4 - Green

 PRIMO BRACCIO

 FIRST ARM

 PREMIER BRAS
ERSTER AUSLEGERARM PRIMO BRAZO 





POS	Codice	 Descrizione	 Description	 Designation	 Benennung	 Descripción
14	172632C4	BIELLA PRIMO- SECONDO BRACCIO COMPLETA	TIEROD FIRST- SECOND BOOM	TIGE PREMIER - DEUXIÈME ARM PLEIN	ROD ERSTE - ZWEITE ARM VOLL	BARRA PRIMERA - SEGUNDO ARM COMPLETO
14	172632CL	BIELLA PRIMO- SECONDO BRACCIO COMPLETA	TIEROD FIRST- SECOND BOOMS	ROD PREMIERS DEUXIÈME BRAS COMPLET	ROD ERSTE ZWEITE- VOLL ARM	BARRA DE PRIMER SEGUNDO BRAZO COMPLETO
14	172632CO	BIELLA PRIMO- SECONDO BRACCIO COMPLETA	TIEROD FIRST- SECOND BOOMS	TIGE PREMIER DEUXIEME ARM PLEIN	ROD ERSTE ZWEITE- ARM VOLL	BARRA PRIMERA SEGUNDA ARM COMPLETO
14	172632D5	BIELLA PRIMO- SECONDO BRACCIO COMPLETA	TIEROD FIRST- SECOND BOOMS	TIGE PREMIER - DEUXIÈME ARM PLEIN	ROD ERSTE - ZWEITE ARM VOLL	BARRA PRIMERA - SEGUNDO ARM COMPLETO
14	172632DI	BIELLA PRIMO- SECONDO BRACCIO COMPLETA	TIEROD FIRST- SECOND BOOMS	TIGE PREMIER - DEUXIÈME ARM PLEIN	ROD ERSTE - ZWEITE ARM VOLL	BARRA PRIMERA - SEGUNDO ARM COMPLETO
14	172632FX	BIELLA PRIMO- SECONDO BRACCIO COMPLETA	TIEROD FIRST- SECOND BOOMS	TIGE PREMIER DEUXIEME ARM PLEIN	ROD ERSTE ZWEITE- ARM VOLL	BARRA PRIMERA SEGUNDA ARM COMPLETO
14	172632GB	BIELLA PRIMO- SECONDO BRACCIO COMPLETA	TIEROD FIRST- SECOND BOOMS	TIGE PREMIER DEUXIEME ARM PLEIN	ROD ERSTE ZWEITE- ARM VOLL	BARRA PRIMERA SEGUNDA ARM COMPLETO
14	172632H1	BIELLA PRIMO- SECONDO BRACCIO COMPLETA	TIEROD FIRST- SECOND BOOMS	ROD PREMIERS DEUXIÈME BRAS COMPLET	ROD ERSTE ZWEITE- VOLL ARM	BARRA DE PRIMER SEGUNDO BRAZO COMPLETO
14	172632H3	BIELLA PRIMO- SECONDO BRACCIO COMPLETA	TIEROD FIRST- SECOND BOOMS	TIGE PREMIER DEUXIEME ARM PLEIN	ROD ERSTE ZWEITE- ARM VOLL	BARRA PRIMERA SEGUNDA ARM COMPLETO
14	172632J1	BIELLA PRIMO- SECONDO BRACCIO COMPLETA	TIEROD FIRST- SECOND BOOMS	ROD PREMIERS DEUXIÈME BRAS COMPLET	ROD ERSTE ZWEITE- VOLL ARM	BARRA DE PRIMER SEGUNDO BRAZO COMPLETO
15	372569A1	RINVIO 1°-2° BRACCIO	UPRIGHT 1ST-2ND BOOMS	REFERENCE 1 ° -2 ° ARM	REFERENCE 1 ° -2 ° ARM	REFERENCIA 1 ° -2 ° ARM
15	372569A3	RINVIO 1°-2° BRACCIO	UPRIGHT 1ST-2ND BOOMS	REFERENCE 1 ° -2 ° ARM	REFERENCE 1 ° -2 ° ARM	REFERENCIA 1 ° -2 ° ARM



Main color codes:  J1 - JLG Cream,  J2 - JLG Orange,  C4 - Green

 PRIMO BRACCIO

 FIRST ARM

 PREMIER BRAS
ERSTER AUSLEGERARM PRIMO BRAZO 





POS	Codice	 Descrizione	 Description	 Designation	 Benennung	 Descripción
15	372569A5	RINVIO 1°-2° BRACCIO	UPRIGHT 1ST-2ND BOOMS	REFERENCE 1 ° -2 ° ARM	REFERENCE 1 ° -2 ° ARM	REFERENCIA 1 ° -2 ° ARM
15	372569A6	RINVIO 1°-2° BRACCIO	UPRIGHT 1ST-2ND BOOMS	REFERENCE 1 ° -2 ° ARM	REFERENCE 1 ° -2 ° ARM	REFERENCIA 1 ° -2 ° ARM
15	372569A7	RINVIO 1°-2° BRACCIO	UPRIGHT 1ST-2ND BOOMS	REFERENCE 1 ° -2 ° ARM	REFERENCE 1 ° -2 ° ARM	REFERENCIA 1 ° -2 ° ARM
15	372569A8	RINVIO 1°-2° BRACCIO	UPRIGHT 1ST-2ND BOOMS	REFERENCE 1 ° -2 ° ARM	REFERENCE 1 ° -2 ° ARM	REFERENCIA 1 ° -2 ° ARM
15	372569A9	RINVIO 1°-2° BRACCIO	UPRIGHT 1ST-2ND BOOMS	REFERENCE 1 ° -2 ° ARM	REFERENCE 1 ° -2 ° ARM	REFERENCIA 1 ° -2 ° ARM
15	372569AG	RINVIO 1°-2° BRACCIO	UPRIGHT 1ST-2ND BOOMS	REFERENCE 1 ° -2 ° ARM	REFERENCE 1 ° -2 ° ARM	REFERENCIA 1 ° -2 ° ARM
15	372569B1	RINVIO 1°-2° BRACCIO	UPRIGHT 1ST-2ND BOOMS	REFERENCE 1 ° -2 ° ARM	REFERENCE 1 ° -2 ° ARM	REFERENCIA 1 ° -2 ° ARM
15	372569BA	RINVIO 1°-2° BRACCIO	UPRIGHT 1ST-2ND BOOMS	REFERENCE 1 ° -2 ° ARM	REFERENCE 1 ° -2 ° ARM	REFERENCIA 1 ° -2 ° ARM
15	372569BC	RINVIO 1°-2° BRACCIO	UPRIGHT 1ST-2ND BOOMS	REFERENCE 1 ° -2 ° ARM	REFERENCE 1 ° -2 ° ARM	REFERENCIA 1 ° -2 ° ARM
15	372569BP	RINVIO 1°-2° BRACCIO	UPRIGHT 1ST-2ND BOOMS	REFERENCE 1 ° -2 ° ARM	REFERENCE 1 ° -2 ° ARM	REFERENCIA 1 ° -2 ° ARM
15	372569C4	RINVIO 1°-2° BRACCIO	UPRIGHT 1ST-2ND BOOMS	REFERENCE 1 ° -2 ° ARM	REFERENCE 1 ° -2 ° ARM	REFERENCIA 1 ° -2 ° ARM
15	372569CL	RINVIO 1°-2° BRACCIO	UPRIGHT 1ST-2ND BOOMS	REFERENCE 1 ° -2 ° ARM	REFERENCE 1 ° -2 ° ARM	REFERENCIA 1 ° -2 ° ARM
15	372569CO	RINVIO 1°-2° BRACCIO	UPRIGHT 1ST-2ND BOOMS	REFERENCE 1 ° -2 ° ARM	REFERENCE 1 ° -2 ° ARM	REFERENCIA 1 ° -2 ° ARM
15	372569D5	RINVIO 1°-2° BRACCIO	UPRIGHT 1ST-2ND BOOMS	REFERENCE 1 ° -2 ° ARM	REFERENCE 1 ° -2 ° ARM	REFERENCIA 1 ° -2 ° ARM
15	372569DI	RINVIO 1°-2° BRACCIO	UPRIGHT 1ST-2ND BOOMS	REFERENCE 1 ° -2 ° ARM	REFERENCE 1 ° -2 ° ARM	REFERENCIA 1 ° -2 ° ARM
15	372569FX	RINVIO 1°-2° BRACCIO	UPRIGHT 1ST-2ND BOOMS	REFERENCE 1 ° -2 ° ARM	REFERENCE 1 ° -2 ° ARM	REFERENCIA 1 ° -2 ° ARM
15	372569GB	RINVIO 1°-2° BRACCIO	UPRIGHT 1ST-2ND BOOMS	REFERENCE 1 ° -2 ° ARM 9006	REFERENCE 1 ° -2 ° ARM 9006	REFERENCIA 1 ° -2 ° ARM 9006



Main color codes:  J1 - JLG Cream,  J2 - JLG Orange,  C4 - Green

 PRIMO BRACCIO

 FIRST ARM

 PREMIER BRAS
ERSTER AUSLEGERARM PRIMO BRAZO 





POS	Codice	 Descrizione	 Description	 Designation	 Benennung	 Descripción
15	372569H1	RINVIO 1°-2° BRACCIO	UPRIGHT 1ST-2ND BOOMS	REFERENCE 1 ° -2 ° ARM	REFERENCE 1 ° -2 ° ARM	REFERENCIA 1 ° -2 ° ARM
15	372569H3	RINVIO 1°-2° BRACCIO	UPRIGHT 1ST-2ND BOOMS	REFERENCE 1 ° -2 ° ARM	REFERENCE 1 ° -2 ° ARM	REFERENCIA 1 ° -2 ° ARM
15	372569J1	RINVIO 1°-2° BRACCIO	UPRIGHT 1ST-2ND BOOMS	REFERENCE 1 ° -2 ° ARM	REFERENCE 1 ° -2 ° ARM	REFERENCIA 1 ° -2 ° ARM
16	084476D2	INDICE ALLINEAMENTO MOBILE - SPEDIRE SEMPRE CON 084477D2	ALIGNMENT INDICATOR - SHIP ALWAYS WITH 084477D2	INDEX D'ALIGNEMENT MOBILE - TOUJOURS LIVRER AVEC 084477D2	MOBILE AUSRICHTUNGSMARKIERUNG - IMMER MIT 084477D2 LIEFERN	ÍNDICE DE ALINEACIÓN MÓVIL - OFRECER SIEMPRE CON 084477D2
17	05849000	PATTINO	SLIDE BLOCK	PATIN	GLEITBLOCK	PATÍN
18	073141H3	STAFFA FISSAGGIO MICROINTERRUTTORE	BRACKET MICROSWITCH	MICRO SUPPORT DE L'INTERRUPTEUR	MICRO SWITCH BRACKET	SOPORTE FIJACIÓN MICRO
19	05427200	LIVELLA	LEVEL	NIVEAU	WASSERWAAGE	NIVEL DE BURBUJA
20	05444800	MOLLA	SPRING	RESSORT	FEDER	MUELLE
21	058832H3	SUPPORTO	SUPPORT	SUPPORT	HALTERUNG	SOPORTE
22	069590H3	PROTEZIONE	PROTECTION	PROTECTION	SCHUTZ	PROTECCIÓN
23	064422Y1	FERMO	RETAINER	ARRÊT	HALTEVORRICHTUNG	BLOQUE
24	064423Y1	PERNO	PIN	GOUJON	ZAPFEN	PERNIO
25	072773H3	SUPPORTO (FOR LL1775-X17JP-X500AJ MK2 FROM C170000893)	SUPPORT (FOR LL1775-X17JP-X500AJ MK2 FROM C170000893)	SOUTIEN (FOR LL1775-X17JP-X500AJ MK2 FROM C170000893)	SUPPORT (FOR LL1775-X17JP-X500AJ MK2 FROM C170000893)	APOYO (FOR LL1775-X17JP-X500AJ MK2 FROM C170000893)
26	07277500	STAFFA ANTERIORE SUPPORTO DISTRIBUTORE	FRONT BRACKET MOUNT DISTRIBUTOR	FRONT MOUNT SUPPORT DISTRIBUTEUR	FRONT MOUNT BRACKET HÄNDLER	FRONT MOUNT SOPORTE DISTRIBUIDOR
26	077097H3	STAFFA	BRACKE	BRIDE	BÜGEL	BRIDA
27	07277400	STAFFA POSTERIORE SUPPORTO DISTRIBUTORE	REAR BRACKET MOUNT DISTRIBUTOR	ARRIÈRE SUPPORT DE MONTAGE DISTRIBUTEUR	REAR BRACKET MOUNT DISTRIBUTOR	REAR MOUNT BRACKET HÄNDLER



Main color codes:  J1 - JLG Cream,  J2 - JLG Orange,  C4 - Green

 PRIMO BRACCIO





 FIRST ARM



 PREMIER BRAS
ERSTER AUSLEGERARM PRIMO BRAZO 



POS	Codice	 Descrizione	 Description	 Designation	 Benennung	 Descripción
27	077096H3	STAFFA POSTERIORE SUPPORTO DISTRIBUTORE LL2010 MK2 (FROM C170000893)	REAR SUPPORT BRACKET DISTRIBUTOR LL2010 MK2 (FROM C170000893)	BRIDE	BÜGEL	BRIDA
28	373142A3	CARTER DISTRIBUTORE BRACCI (FOR LL1775- X17JP-X500AJ MK2 FROM C170000893)	CARTER BOOM HYDRAULIC DISTRIBUTOR (FOR LL1775-X17JP-X500AJ MK2 FROM C170000893)	CARTER DISTRIBUTEUR (FOR LL1775-X17JP-X500AJ MK2 FROM C170000893)	CARTER HÄNDLER (FOR LL1775-X17JP- X500AJ MK2 FROM C170000893)	CARTER DISTRIBUIDOR (FOR LL1775-X17JP-X500AJ MK2 FROM C170000893)
28	373142H2	CARTER DISTRIBUTORE BRACCI (FOR LL1775- X17JP-X500AJ MK2 FROM C170000893)	PROTECTION BOOM HYDRAULIC DISTRIBUTOR (FOR LL1775-X17JP-X500AJ MK2 FROM C170000893)	PROTECTION DISTRIBUTEUR (FOR LL1775-X17JP-X500AJ MK2 FROM C170000893)	SCHUTZ VENTILBLOCK (FOR LL1775-X17JP-X500AJ MK2 FROM C170000893)	PROTECCION DISTRIBUIDOR (FOR LL1775-X17JP-X500AJ MK2 FROM C170000893)
29	073144A3	COPERCHIO (FOR LL1775-X17JP-X500AJ MK2 FROM C170000893)	COVER (FOR LL1775- X17JP-X500AJ MK2 FROM C170000893)	COUVERTURE (FOR LL1775-X17JP-X500AJ MK2 FROM C170000893)	ABDECKUNG (FOR LL1775-X17JP-X500AJ MK2 FROM C170000893)	CUBIERTA (FOR LL1775-X17JP-X500AJ MK2 FROM C170000893)
29	073144H2	COPERCHIO (FOR LL1775-X17JP-X500AJ MK2 FROM C170000893)	COVER (FOR LL1775- X17JP-X500AJ MK2 FROM C170000893)	COUVERTURE (FOR LL1775-X17JP-X500AJ MK2 FROM C170000893)	DECKUNG (FOR LL1775-X17JP-X500AJ MK2 FROM C170000893)	COBERTURA (FOR LL1775-X17JP-X500AJ MK2 FROM C170000893)
29	07505900	COPERCHIO SENZA CHIAVE VERSIONE ANSI (FOR LL1775- X17JP-X500AJ MK2 FROM C170000893)	COVER WITHOUT KEY ANSI VERSION (FOR LL1775-X17JP- X500AJ MK2 FROM C170000893)	COUVERTURE (FOR LL1775-X17JP-X500AJ MK2 FROM C170000893)	COVER (FOR LL1775- X17JP-X500AJ MK2 FROM C170000893)	CUBIERTA (FOR LL1775-X17JP-X500AJ MK2 FROM C170000893)



Main color codes:  J1 - JLG Cream,  J2 - JLG Orange,  C4 - Green

 PRIMO BRACCIO FIRST ARM PREMIER BRASERSTER AUSLEGERARM PRIMO BRAZO 



POS	Codice	 Descrizione	 Description	 Designation	 Benennung	 Descripción
29	075059H2	COPERCHIO SENZA CHIAVE VERSIONE ANSI (FOR LL1775-X17JP-X500AJ MK2 FROM C170000893)	COVER WITHOUT KEY ANSI VERSION (FOR LL1775-X17JP-X500AJ MK2 FROM C170000893)	COUVERTURE SANS CLÉ (FOR LL1775-X17JP-X500AJ MK2 FROM C170000893)	DECKUNG OHNE SCHLÜSSEL (FOR LL1775-X17JP-X500AJ MK2 FROM C170000893)	COBERTURA SIN LLAVE (FOR LL1775-X17JP-X500AJ MK2 FROM C170000893)
30	07178800	SERRATURA	LOCK	SERRURE	SCHLOSS	CERRADURA
31	07298800	CHIAVE PER SERRATURA POSTAZIONE COMANDO A TERRA	KEY TO THE LOCK ON THE GROUND CONTROL POSITION	CLÉ	SCHLÜSSEL	LLAVE
33	07178900	CAMMA PER SERRATURA DISASSAMENTO 3.2	CAM LOCK FOR OFFSET 3.2	CAME	NOCKEN	LEVA
34	06551600	PINZA	PLIERS	PINCE	KLEMME	PINZA
35	073138Y1	SUPPORTO SERRATURA	LOCK SUPPORT	SUPPORT SERRURE	SCHLOSSHALTERUNG	SOPORTE CERRADURA
36	06838700	TAPPO	CAP	BOUCHON	VERSCHLUSS	TAPÓN

Main color codes:  J1 - JLG Cream,  J2 - JLG Orange,  C4 - Green

-  SECONDO BRACCIO
-  SECOND ARM
-  SECOND BRAS

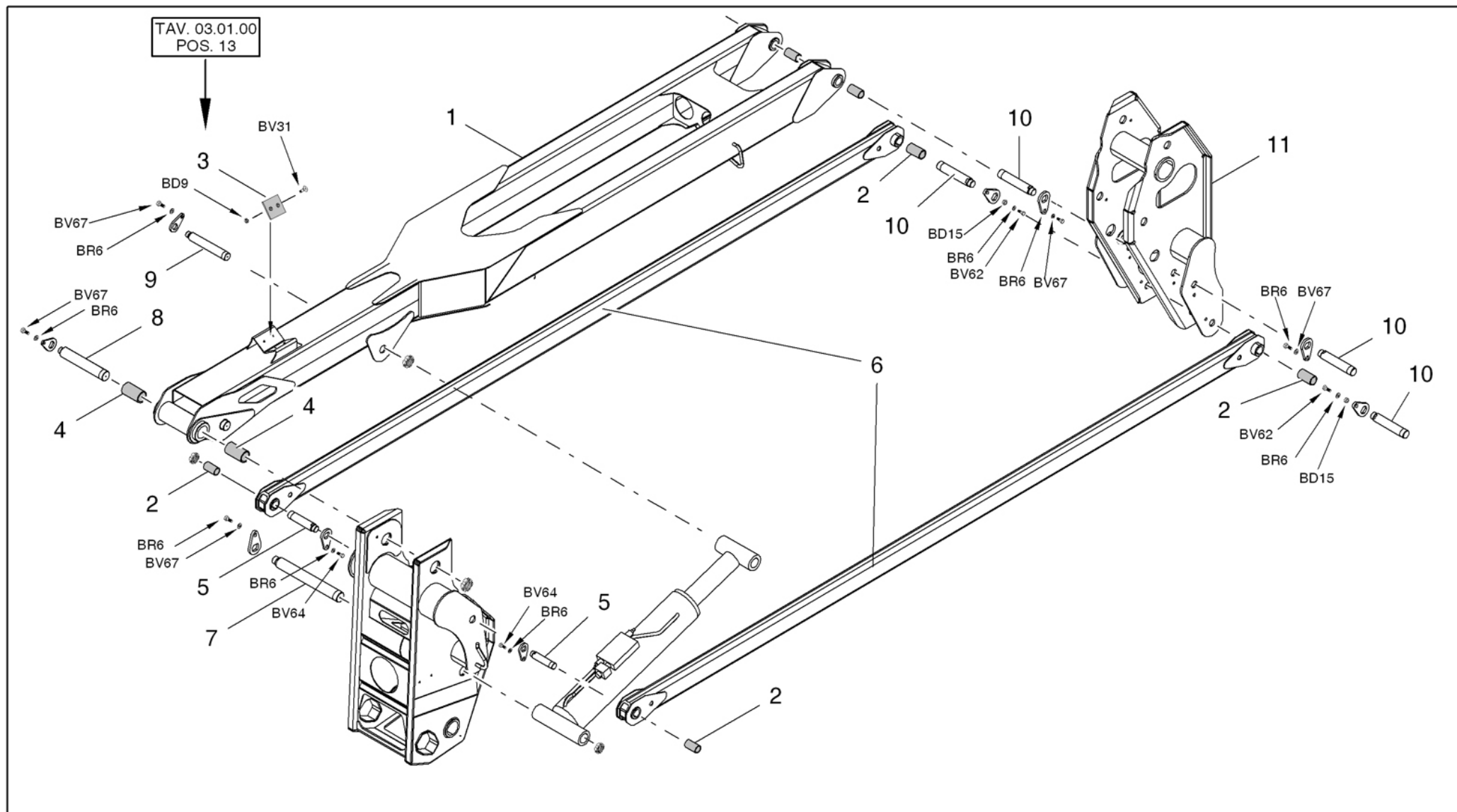
- ZWEITER AUSLEGERARM 
- SEGUNDO BRAZO 











Main color codes:  J1 - JLG Cream,  J2 - JLG Orange,  C4 - Green

 SECONDO BRACCIO

 SECOND ARM

 SECOND BRAS
ZWEITER AUSLEGERARM SEGUNDO BRAZO 





POS	Codice	 Descrizione	 Description	 Designation	 Benennung	 Descripción
1	172545A1	SECONDO BRACCIO COMPLETO	SECOND BOOM	ARM DEUXIÈME COMPLETE	ARM COMPLETE SECOND	BRAZO COMPLETO SEGUNDO
1	172545A3	SECONDO BRACCIO COMPLETO	SECOND BOOM	ARM DEUXIÈME COMPLETE	ARM COMPLETE SECOND	BRAZO COMPLETO SEGUNDO
1	172545A5	SECONDO BRACCIO COMPLETO	SECOND BOOM	ARM DEUXIÈME COMPLETE	ARM COMPLETE SECOND	BRAZO COMPLETO SEGUNDO
1	172545A6	SECONDO BRACCIO COMPLETO	SECOND BOOM	ARM DEUXIÈME COMPLETE	ARM COMPLETE SECOND	BRAZO COMPLETO SEGUNDO
1	172545A7	SECONDO BRACCIO COMPLETO	SECOND BOOM	ARM DEUXIÈME COMPLETE	ARM COMPLETE SECOND	BRAZO COMPLETO SEGUNDO
1	172545A8	SECONDO BRACCIO COMPLETO	SECOND BOOM	ARM DEUXIÈME COMPLETE	ARM COMPLETE SECOND	BRAZO COMPLETO SEGUNDO
1	172545A9	SECONDO BRACCIO COMPLETO	SECOND BOOM	ARM DEUXIÈME COMPLETE	ARM COMPLETE SECOND	BRAZO COMPLETO SEGUNDO
1	172545AG	SECONDO BRACCIO COMPLETO	SECOND BOOM	ARM DEUXIÈME COMPLETE	ARM COMPLETE SECOND	ARM SEGUNDO COMPLETO
1	172545B1	SECONDO BRACCIO COMPLETO	SECOND BOOM	ARM DEUXIÈME COMPLETE	ARM COMPLETE SECOND	BRAZO COMPLETO SEGUNDO
1	172545BA	SECONDO BRACCIO COMPLETO	SECOND BOOM	ARM DEUXIÈME COMPLETE	ARM COMPLETE SECOND	BRAZO COMPLETO SEGUNDO
1	172545BC	SECONDO BRACCIO	SECOND BOOM	ARM DEUXIÈME COMPLETE	ARM COMPLETE SECOND	BRAZO COMPLETO SEGUNDO
1	172545BP	SECONDO BRACCIO COMPLETO	SECOND BOOM	ARM DEUXIÈME COMPLETE	ARM COMPLETE SECOND	BRAZO COMPLETO SEGUNDO
1	172545C4	SECONDO BRACCIO COMPLETO	SECOND BOOM	ARM DEUXIÈME COMPLETE	ARM COMPLETE SECOND	BRAZO COMPLETO SEGUNDO
1	172545CL	SECONDO BRACCIO COMPLETO	SECOND BOOM	ARM DEUXIÈME COMPLETE	ARM COMPLETE SECOND	ARM SEGUNDO COMPLETO
1	172545CO	SECONDO BRACCIO COMPLETO	SECOND BOOM	ARM DEUXIÈME COMPLETE	ARM COMPLETE SECOND	BRAZO COMPLETO SEGUNDO
1	172545D5	SECONDO BRACCIO COMPLETO	SECOND BOOM	ARM DEUXIÈME COMPLETE	ARM COMPLETE SECOND	BRAZO COMPLETO SEGUNDO
1	172545DI	SECONDO BRACCIO COMPLETO	SECOND BOOM	ARM DEUXIÈME COMPLETE	ARM COMPLETE SECOND	BRAZO COMPLETO SEGUNDO



Main color codes:  J1 - JLG Cream,  J2 - JLG Orange,  C4 - Green

 SECONDO BRACCIO

 SECOND ARM

 SECOND BRAS
ZWEITER AUSLEGERARM SEGUNDO BRAZO 





POS	Codice	 Descrizione	 Description	 Designation	 Benennung	 Descripción
1	172545FX	SECONDO BRACCIO COMPLETO	SECOND BOOM	ARM DEUXIÈME COMPLETE	ARM COMPLETE SECOND	BRAZO COMPLETO SEGUNDO
1	172545GB	SECONDO BRACCIO COMPLETO	SECOND BOOM	ARM DEUXIÈME COMPLETE	ARM COMPLETE SECOND	BRAZO COMPLETO SEGUNDO
1	172545H1	SECONDO BRACCIO COMPLETO	SECOND BOOM	ARM DEUXIÈME COMPLETE	ARM COMPLETE SECOND	ARM SEGUNDO COMPLETO
1	172545H3	SECONDO BRACCIO COMPLETO	SECOND BOOM	ARM DEUXIÈME COMPLETE	ARM COMPLETE SECOND	BRAZO COMPLETO SEGUNDO
1	172545J1	SECONDO BRACCIO COMPLETO	SECOND BOOM	ARM DEUXIÈME COMPLETE	ARM COMPLETE SECOND	ARM SEGUNDO COMPLETO
2	06326300	BOCCOLA	BUSH	DOUILLE	BUCHSE	CASQUILLO
4	06422100	BOCCOLA	BUSH	DOUILLE	LUFTÖFFNUNG	BOQUILLA AIRE
5	07271200	SPINA	PIN	CHEVILLE	STIF	CLAVIJA
6	172656A1	TIRANTE SECONDO BRACCIO COMPLETO	TIE ROD SECOND BOOM	TIE DEUXIÈME ARM SOLD OUT	TIE ZWEITE ARM AUSVERKAUFT	TIE SEGUNDO ARM TERMINADO
6	172656A3	TIRANTE SECONDO BRACCIO COMPLET	TIE ROD SECOND BOOM	TIE DEUXIÈME ARM SOLD OUT	TIE ZWEITE ARM AUSVERKAUFT	TIE SEGUNDO ARM TERMINADO
6	172656A5	TIRANTE SECONDO BRACCIO COMPLETO	TIE ROD SECOND BOOM	TIE DEUXIÈME ARM SOLD OUT	TIE ZWEITE ARM AUSVERKAUFT	TIE SEGUNDO ARM TERMINADO
6	172656A6	TIRANTE SECONDO BRACCIO COMPLETO	TIE ROD SECOND BOOM	TIE DEUXIÈME ARM SOLD OUT	TIE ZWEITE ARM AUSVERKAUFT	TIE SEGUNDO ARM TERMINADO
6	172656A7	TIRANTE SECONDO BRACCIO COMPLETO	TIE ROD SECOND BOOM	TIE DEUXIÈME ARM SOLD OU	TIE ZWEITE ARM AUSVERKAUFT	TIE SEGUNDO ARM TERMINADO
6	172656A8	TIRANTE SECONDO BRACCIO COMPLET	TIE ROD SECOND BOOM	TIE DEUXIÈME ARM SOLD OUT	TIE ZWEITE ARM AUSVERKAUFT	TIE SEGUNDO ARM TERMINADO
6	172656A9	TIRANTE SECONDO BRACCIO COMPLETO	TIE ROD SECOND BOOM	TIE DEUXIÈME ARM SOLD OUT	TIE SEGUNDO ARM TERMINADO	TIE SEGUNDO ARM TERMINADO
6	172656AG	TIRANTE SECONDO BRACCIO COMPLETO	TIE ROD SECOND BOOM	TIE DEUXIÈME ARM SOLD OUT	TIE ZWEITE ARM AUSVERKAUFT	TIE SEGUNDO ARM TERMINADO
6	172656B1	TIRANTE SECONDO BRACCIO COMPLETO	TIE ROD SECOND BOOM	TIE DEUXIÈME ARM SOLD OUT	TIE ZWEITE ARM AUSVERKAUFT	TIE SEGUNDO ARM TERMINADO
6	172656BA	TIRANTE SECONDO BRACCIO COMPLETO	TIE ROD SECOND BOOM	TIE DEUXIÈME ARM SOLD OUT	TIE ZWEITE ARM AUSVERKAUFT	TIE SEGUNDO ARM TERMINADO



Main color codes:  J1 - JLG Cream,  J2 - JLG Orange,  C4 - Green

 SECONDO BRACCIO

 SECOND ARM

 SECOND BRAS
ZWEITER AUSLEGERARM SEGUNDO BRAZO 





POS	Codice	 Descrizione	 Description	 Designation	 Benennung	 Descripción
6	172656BC	TIRANTE SECONDO BRACCIO COMPLETO	TIE ROD SECOND BOOM	TIE DEUXIÈME ARM SOLD OUT	TIE ZWEITE ARM AUSVERKAUFT	TIE SEGUNDO ARM TERMINADO
6	172656BP	TIRANTE SECONDO BRACCIO COMPLET	TIE ROD SECOND BOOM	TIE DEUXIÈME ARM SOLD OUT	TIE ZWEITE ARM AUSVERKAUFT	TIE SEGUNDO ARM TERMINADO
6	172656C4	TIRANTE SECONDO BRACCIO COMPLETO	TIE ROD SECOND BOOM	TIE DEUXIÈME ARM SOLD OUT	TIE ZWEITE ARM AUSVERKAUFT	TIE SEGUNDO ARM TERMINADO
6	172656CL	TIRANTE SECONDO BRACCIO COMPLETO	TIE ROD SECOND BOOM	TIE DEUXIÈME ARM SOLD OUT	TIE ZWEITE ARM AUSVERKAUFT	TIE SEGUNDO ARM TERMINADO
6	172656CO	TIRANTE SECONDO BRACCIO COMPLETO	TIE ROD SECOND BOOM	TIE DEUXIÈME ARM SOLD OUT	TIE SEGUNDO ARM TERMINADO	TIE SEGUNDO ARM TERMINADO
6	172656D5	TIRANTE SECONDO BRACCIO COMPLETO	TIE ROD SECOND BOOM	TIE DEUXIÈME ARM SOLD OUT	TIE ZWEITE ARM AUSVERKAUFT	TIE SEGUNDO ARM TERMINADO
6	172656DI	TIRANTE SECONDO BRACCIO COMPLETO	TIE ROD SECOND BOOM	TIE DEUXIÈME ARM SOLD OUT	TIE ZWEITE ARM AUSVERKAUFT	TIE SEGUNDO ARM TERMINAD
6	172656FX	TIRANTE SECONDO BRACCIO COMPLETO	TIE ROD SECOND BOOM	TIE DEUXIÈME ARM SOLD OUT	TIE ZWEITE ARM AUSVERKAUFT	TIE SEGUNDO ARM TERMINADO
6	172656GB	TIRANTE SECONDO BRACCIO COMPLETO	TIE ROD SECOND BOOM	TIE DEUXIÈME ARM SOLD OUT	TIE SEGUNDO ARM TERMINADO	TIE SEGUNDO ARM TERMINADO
6	172656H1	TIRANTE SECONDO BRACCIO COMPLETO	TIE ROD SECOND BOOM	TIE DEUXIÈME ARM SOLD OUT	TIE ZWEITE ARM AUSVERKAUFT	TIE SEGUNDO ARM TERMINADO
6	172656H3	TIRANTE SECONDO BRACCIO COMPLETO	TIE ROD SECOND BOOM	TIE DEUXIÈME ARM SOLD OUT	TIE SEGUNDO ARM TERMINADO	TIE SEGUNDO ARM TERMINADO
6	172656J1	TIRANTE SECONDO BRACCIO COMPLETO	TIE ROD SECOND BOOM	TIE DEUXIÈME ARM SOLD OUT	TIE ZWEITE ARM AUSVERKAUFT	TIE SEGUNDO ARM TERMINADO
7	07271100	SPINA	PIN	CHEVILLE	STIF	CLAVIJA
8	07271300	SPINA	PIN	CHEVILLE	STIF	CLAVIJA
9	07271500	SPINA	PIN	CHEVILLE	STIF	CLAVIJA
10	07271600	SPINA	PIN	CHEVILLE	STIF	CLAVIJA
11	372515A1	RINVIO 2°-3° BRACCIO	UPRIGHT 2ND-3RD BOOMS	REFERENCE 2 ° -3 ° ARM	REFERENZ 2 ° -3 ° ARM	REFERENCIA 2 ° -3 ° ARM
11	372515A3	RINVIO 2°-3° BRACCIO	UPRIGHT 2ND-3RD BOOMS	REFERENCE 2 ° -3 ° ARM	REFERENZ 2 ° -3 ° ARM	REFERENCIA 2 ° -3 ° ARM
11	372515A5	RINVIO 2°-3° BRACCIO	UPRIGHT 2ND-3RD BOOMS	REFERENCE 2 ° -3 ° ARM	REFERENZ 2 ° -3 ° ARM	REFERENCIA 2 ° -3 ° ARM



Main color codes:  J1 - JLG Cream,  J2 - JLG Orange,  C4 - Green



 SECONDO BRACCIO





 SECOND ARM



 SECOND BRAS
ZWEITER AUSLEGERARM SEGUNDO BRAZO 

POS	Codice	 Descrizione	 Description	 Designation	 Benennung	 Descripción
11	372515A6	RINVIO 2°-3° BRACCIO	UPRIGHT 2ND-3RD BOOMS	REFERENCE 2 ° -3 ° ARM	REFERENZ 2 ° -3 ° ARM	REFERENCIA 2 ° -3 ° ARM R
11	372515A7	RINVIO 2°-3° BRACCIO	UPRIGHT 2ND-3RD BOOMS	REFERENCE 2 ° -3 ° ARM	REFERENZ 2 ° -3 ° ARM	REFERENCIA 2 ° -3 ° ARM
11	372515A8	RINVIO 2°-3° BRACCIO	UPRIGHT 2ND-3RD BOOMS	REFERENCE 2 ° -3 ° ARM	REFERENZ 2 ° -3 ° ARM	REFERENCIA 2 ° -3 ° ARM
11	372515A9	RINVIO 2°-3° BRACCIO	UPRIGHT 2ND-3RD BOOMS	REFERENCE 2 ° -3 ° ARM	REFERENZ 2 ° -3 ° ARM	REFERENCIA 2 ° -3 ° ARM
11	372515AG	RINVIO 2°-3° BRACCIO	UPRIGHT 2ND-3RD BOOMS	REFERENCE 2 ° -3 ° ARM	REFERENZ 2 ° -3 ° ARM	REFERENCIA 2 ° -3 ° ARM
11	372515B1	RINVIO 2°-3° BRACCIO	UPRIGHT 2ND-3RD BOOMS	REFERENCE 2 ° -3 ° ARM	REFERENZ 2 ° -3 ° ARM	REFERENCIA 2 ° -3 ° ARM
11	372515BA	RINVIO 2°-3° BRACCIO	UPRIGHT 2ND-3RD BOOMS	REFERENCE 2 ° -3 ° ARM	REFERENZ 2 ° -3 ° ARM	REFERENCIA 2 ° -3 ° ARM
11	372515BC	RINVIO 2°-3° BRACCIO	UPRIGHT 2ND-3RD BOOMS	REFERENCE 2 ° -3 ° ARM	REFERENZ 2 ° -3 ° ARM	REFERENCIA 2 ° -3 ° ARM
11	372515BP	RINVIO 2°-3° BRACCIO	UPRIGHT 2ND-3RD BOOMS	REFERENCE 2 ° -3 ° ARM	REFERENZ 2 ° -3 ° ARM	REFERENCIA 2 ° -3 ° ARM
11	372515C4	RINVIO 2°-3° BRACCIO	UPRIGHT 2ND-3RD BOOMS	REFERENCE 2 ° -3 ° ARM	REFERENZ 2 ° -3 ° ARM	REFERENCIA 2 ° -3 ° ARM
11	372515CL	RINVIO 2°-3° BRACCIO	UPRIGHT 2ND-3RD BOOMS	REFERENCE 2 ° -3 ° ARM	REFERENZ 2 ° -3 ° ARM	REFERENCIA 2 ° -3 ° ARM
11	372515CO	RINVIO 2°-3° BRACCIO	UPRIGHT 2ND-3RD BOOMS	REFERENCE 2 ° -3 ° ARM	REFERENZ 2 ° -3 ° ARM	REFERENCIA 2 ° -3 ° ARM
11	372515D5	RINVIO 2°-3° BRACCIO	UPRIGHT 2ND-3RD BOOMS	REFERENCE 2 ° -3 ° ARM	REFERENZ 2 ° -3 ° ARM	REFERENCIA 2 ° -3 ° ARM
11	372515DI	RINVIO 2°-3° BRACCIO	UPRIGHT 2ND-3RD BOOMS	REFERENCE 2 ° -3 ° ARM	REFERENZ 2 ° -3 ° ARM	REFERENCIA 2 ° -3 ° ARM
11	372515FX	RINVIO 2°-3° BRACCIO	UPRIGHT 2ND-3RD BOOMS	REFERENCE 2 ° -3 ° ARM	REFERENZ 2 ° -3 ° ARM	REFERENCIA 2 ° -3 ° ARM
11	372515GB	RINVIO 2°-3° BRACCIO	UPRIGHT 2ND-3RD BOOMS	REFERENCE 2 ° -3 ° ARM	REFERENZ 2 ° -3 ° ARM	REFERENCIA 2 ° -3 ° ARM
11	372515H1	RINVIO 2°-3° BRACCIO	UPRIGHT 2ND-3RD BOOMS	REFERENCE 2 ° -3 ° ARM	REFERENZ 2 ° -3 ° ARM	REFERENCIA 2 ° -3 ° ARM

Main color codes:  J1 - JLG Cream,  J2 - JLG Orange,  C4 - Green

 SECONDO BRACCIO SECOND ARM SECOND BRASZWEITER AUSLEGERARM SEGUNDO BRAZO 

POS	Codice	 Descrizione	 Description	 Designation	 Benennung	 Descripción
11	372515H3	RINVIO 2°-3° BRACCIO	UPRIGHT 2ND-3RD BOOMS	REFERENCE 2 ° -3 ° ARM	REFERENZ 2 ° -3 ° ARM	REFERENCIA 2 ° -3 ° ARM
11	372515J1	RINVIO 2°-3° BRACCIO	UPRIGHT 2ND-3RD BOOMS	REFERENCE 2 ° -3 ° ARM	REFERENZ 2 ° -3 ° ARM	REFERENCIA 2 ° -3 ° ARM



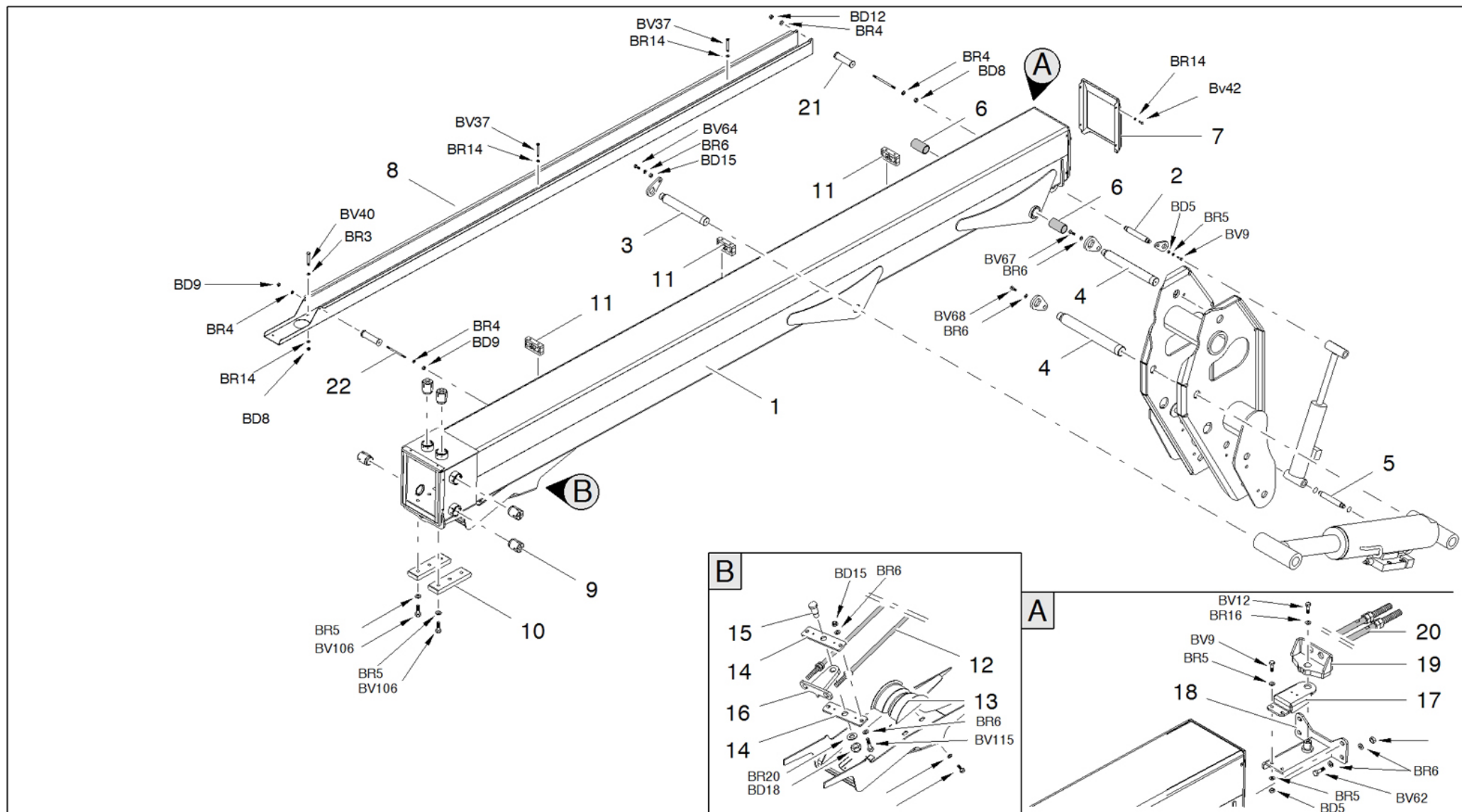

Main color codes:  J1 - JLG Cream,  J2 - JLG Orange,  C4 - Green





 TERZO BRACCIO

 THIRD ARM

 TIERS BRAS
THIRD AUSLEGERARM TERCERO BRAZO 

POS	Codice	 Descrizione	 Description	 Designation	 Benennung	 Descripció
1	172275A1	TERZO BRACCIO	THIRD ARM	TROISIÈME BRAS	DRITTER AUSLEGERARM	TERCER BRAZO
1	172275A3	TERZO BRACCIO	THIRD ARM	TROISIÈME BRAS	DRITTER AUSLEGERARM	TERCER BRAZO
1	172275A5	TERZO BRACCIO	THIRD ARM	TROISIÈME BRAS	DRITTER AUSLEGERARM	TERCER BRAZO
1	172275A6	TERZO BRACCIO	THIRD ARM	TROISIÈME BRAS	DRITTER AUSLEGERARM	TERCER BRAZO
1	172275A7	TERZO BRACCIO	THIRD ARM	TROISIÈME BRAS	DRITTER AUSLEGERARM	TERCER BRAZO
1	172275A8	TERZO BRACCIO	THIRD ARM	TROISIÈME BRAS	DRITTER AUSLEGERARM	TERCER BRAZO
1	172275A9	TERZO BRACCIO	THIRD ARM	TROISIÈME BRAS	DRITTER AUSLEGERARM	TERCER BRAZO
1	172275AG	TERZO BRACCIO	THIRD ARM	TROISIÈME BRAS	DRITTER AUSLEGERARM	TERCER BRAZO
1	172275B1	TERZO BRACCIO	THIRD ARM	TROISIÈME BRAS	DRITTER AUSLEGERARM	TERCER BRAZO
1	172275BA	TERZO BRACCIO	THIRD ARM	TROISIÈME BRAS	DRITTER AUSLEGERARM	TERCER BRAZO
1	172275BC	TERZO BRACCIO	THIRD ARM	TROISIÈME BRAS	DRITTER AUSLEGERARM	TERCER BRAZO
1	172275BP	TERZO BRACCIO	THIRD ARM	TROISIÈME BRAS	DRITTER AUSLEGERARM	TERCER BRAZO
1	172275C4	TERZO BRACCIO	THIRD ARM	TROISIÈME BRAS	DRITTER AUSLEGERARM	TERCER BRAZO
1	172275CL	TERZO BRACCIO	THIRD ARM	TROISIÈME BRAS	DRITTER AUSLEGERARM	TERCER BRAZO
1	172275CO	TERZO BRACCIO	THIRD ARM	TROISIÈME BRAS	DRITTER AUSLEGERARM	TERCER BRAZO
1	172275D5	TERZO BRACCIO	THIRD ARM	TROISIÈME BRAS	DRITTER AUSLEGERARM	TERCER BRAZO
1	172275DI	TERZO BRACCIO	THIRD ARM	TROISIÈME BRAS	DRITTER AUSLEGERARM	TERCER BRAZO



Main color codes:  J1 - JLG Cream,  J2 - JLG Orange,  C4 - Green

 TERZO BRACCIO

 THIRD ARM

 TIERS BRAS
THIRD AUSLEGERARM TERCERO BRAZO 

POS	Codice	 Descrizione	 Description	 Designation	 Benennung	 Descripción
1	172275FX	TERZO BRACCIO	THIRD ARM	TROISIÈME BRAS	DRITTER AUSLEGERARM	TERCER BRAZO
1	172275GB	TERZO BRACCIO	THIRD ARM	TROISIÈME BRAS	DRITTER AUSLEGERARM	TERCER BRAZO
1	172275H1	TERZO BRACCIO	THIRD ARM	TROISIÈME BRAS	DRITTER AUSLEGERARM	TERCER BRAZO
1	172275H3	TERZO BRACCIO	THIRD ARM	TROISIÈME BRAS	DRITTER AUSLEGERARM	TERCER BRAZO
1	172275J1	TERZO BRACCIO	THIRD ARM	TROISIÈME BRAS	DRITTER AUSLEGERARM	TERCER BRAZO
2	06230600	SPINA	PIN	CHEVILLE	STIFT	CLAVIJA
3	07278800	SPINA	PIN	CHEVILLE	STIF	CLAVIJA
4	07271700	SPINA	PIN	CHEVILLE	STIF	CLAVIJA
5	06867600	SPINA	PIN	CHEVILLE	STIFT	CLAVIJA
6	06422200	BOCCOLA	BUSH	DOUILLE	BUCHSE	CASQUILLO
7	072481H3	CARTER CHIUSURA TERZO BRACCIO	COVER THIRD ARM	COUVERTURE TROISIEME BRAS	COVER DRITTEN ARM	COBERTURA DO BRAÇO TERCEIRO
8	072472H3	PIEGATO SUPPORTO CATENARIA	SUPPORT	SUPPORT	HALTERUNG	SOPORTE
9	07246000	PATTINO IN PLASTICA	SLIDE BLOCK	PATIN	GLEITBLOCK	PATIN
10	07246700	PATTINO IN PLASTICA	SLIDE BLOCK	PATIN	GLEITELEMENT	PATIN
11	07284000	MORSETTO FERMA TUBI	CLAMP	PIPE CLAMP ARRÊTS	BOHRROHRKLEMME STOPPT	ABRAZADERA SE DETIENE
11	07874500	MORSETTO FERMA TUBI	CLAMP	PIPE CLAMP ARRÊTS	BOHRROHRKLEMME STOPPT	ABRAZADERA SE DETIENE
12	07247100	FUNE RIENTRO SFILO	ROPE EXTENSION IN	CABLE EXTENSION DE SORTIE	KABELVERLÄNGERU NG AUSGANG	CABLE DE EXTENSIÓN DE SALIDA
13	06306200	SLITTA	SLIDE	COULISSEAU	SCHLITTEN	CORREDERA
14	066189Y1	LAMA DI FISSAGGIO	FIXING BLADE	LAME DE FIXAGE	BEFESTIGUNGSSCHIL D	LAMA FIJACIÓN
15	06619000	PERNO	PIN	GOUJON	ZAPFEN	PERNIO

Main color codes:  J1 - JLG Cream,  J2 - JLG Orange,  C4 - Green





 TERZO BRACCIO



 THIRD ARM



 TIERS BRAS

 THIRD AUSLEGERARM



 TERCERO BRAZO

POS	Codice	 Descrizione	 Description	 Designation	 Benennung	 Descripción
16	366192Y1	PIATTO CONTENIMENTO FUNI	PLATE FOR CABLES	PLAQUE POUR CÂBLES	SEILHALTER	PLACA PARA CABLES
17	063061Y1	SUPPORTO	SUPPORT	SUPPORT	HALTERUNG	SOPORTE
18	363078Y1	SUPPORTO	SUPPORT	SUPPORT	HALTERUNG	SOPORTE
19	363074Y1	BILANCERE	ROCKER ARM	BALANCIER	KIPPHEBEL	BALANCÍN
20	07247000	FUNE SFILO USCITA	ROPE FOR EXTENSION EXIT	CABLE EXTENSION DE SORTIE	CABLE EXTENSION OUTPUT	CABLE DE EXTENSIÓN DE SALIDA
21	06518800	DISTANZIALE	SPACER	ENTRETOISE	DISTANZSTÜCK	DISTANCIADOR
22	06518900	TIRANTE	TIE ROD	TIRANT	TURMGESTÄNGE	TIRANTE

-  PRIMO SFILÒ
-  FIRST EXTENSION ARM
-  PREMIER BRAS D'EXTRACTION

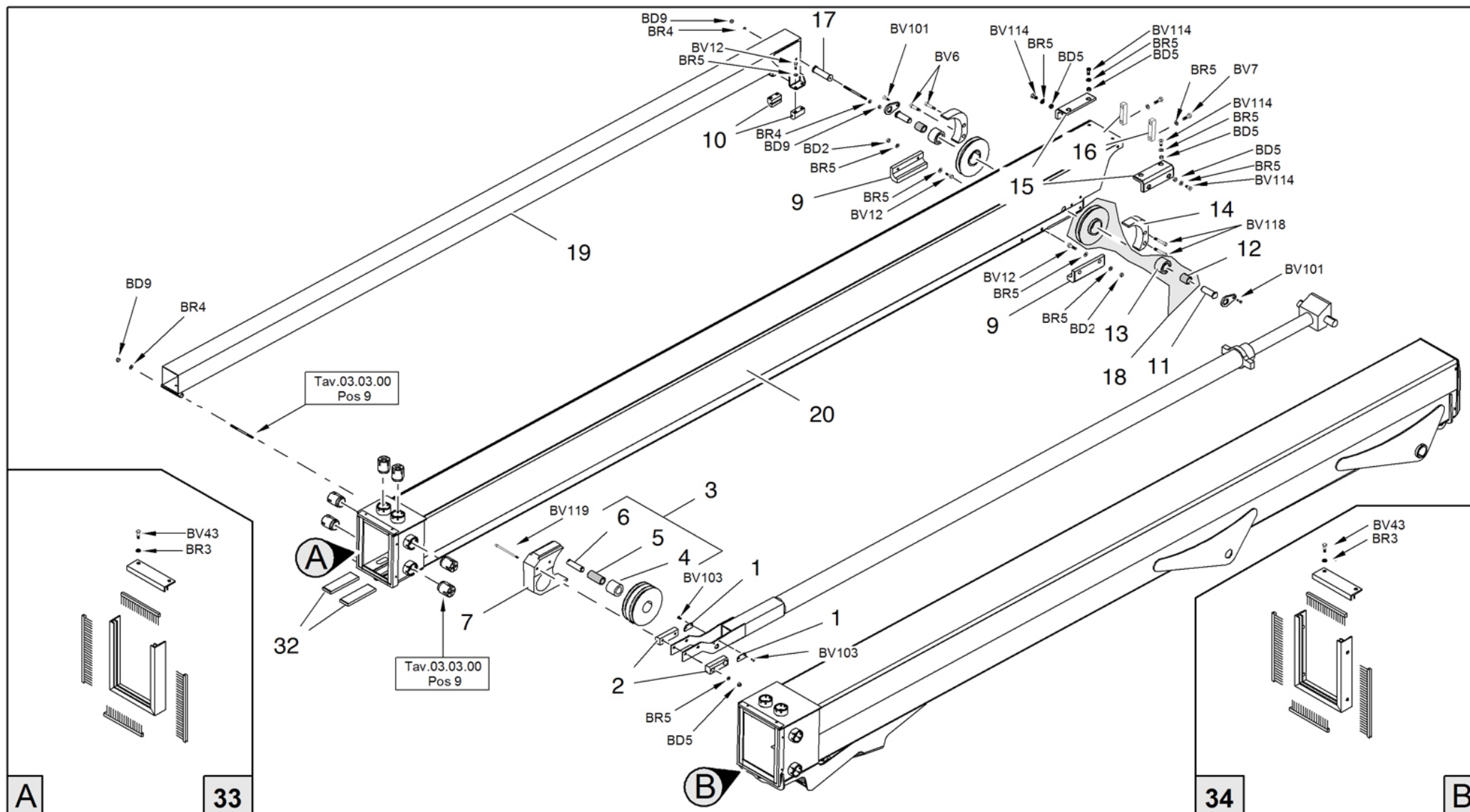
ERSTER TELESKOPARM 
 PRIMO BRAZO DE EXTENSION 





Main color codes:  J1 - JLG Cream,  J2 - JLG Orange,  C4 - Green



 PRIMO SFILO



 FIRST EXTENSION ARM





 PREMIER BRAS D'EXTRACTION
ERSTER TELESKOPARM PRIMO BRAZO DE EXTENSION 



POS	Codice	 Descrizione	 Description	 Designation	 Benennung	 Descripción
1	072787Y1	PIATTO	PLATE	PLATEAU	PLATTE	PLACA
2	06308800	PATTINO	SLIDE BLOCK	PATIN	GLEITBLOCK	PATÍN
3	16510800	PULEGGIA	PULLEY	POULIE	SCHEIBE	POLEA
4	06321100	BOCCOLA	BUSH	DOUILLE	BUCHSE	CASQUILLO
5	06422400	BOCCOLA	BUSH	DOUILLE	BUCHSE	CASQUILLO
6	06309900	SPINA	PIN	CHEVILLE	STIFT	CLAVIJA
7	07246900	PATTINO IN PLASTICA	SLIDE BLOCK	PLASTIQUE DE CHAUSSURE	SCHUH KUNSTSTOFF	PLÁSTICO DE ZAPATOS
9	07246400	PATTINO IN PLASTICA	SLIDE BLOCK	PLASTIQUE DE CHAUSSURE	SCHUH KUNSTSTOFF	PLÁSTICO DE ZAPATOS
10	06624100	GUIDA	GUIDE	GLISSIÈRE	FÜHRUNG	GUÍA
11	07271900	SPINA	PIN	CHEVILLE	STIF	CLAVIJA
12	06422300	BOCCOLA	BUSH	DOUILLE	BUCHSE	CASQUILLO
13	06321200	BOCCOLA	BUSH	DOUILLE	BUCHSE	CASQUILLO
14	06623000	PATTINO	SLIDE BLOCK	PATIN	GLEITBLOCK	PATÍN
15	07246300	PATTINO IN PLASTICA	SLIDE BLOCK	PLASTIQUE DE CHAUSSURE	SCHUH KUNSTSTOFF	PLÁSTICO DE ZAPATOS
16	083319Y2	PIATTO	PLATE	PLATEAU	PLATTE	PLACA
17	06539700	RULLO	ROLLER	ROULEAU	ROLLE	RODILLO
18	16710000	PULEGGIA	PULLEY	POULIE	SCHEIBE	POLEA
19	372475H3	SUPPORTO CATENARIA SU PRIMO SFILO	SUPPORT CABLE HOLDER CHAIN ON FIRST EXTENSION BOOM	APPUI AERIEN SUR PREMIÈRE EXTENSION	OBENLIEGENDE SUPPORT ON ERSTE ERWEITERUNG	APOYO SUPERIOR EN PRIMERA AMPLIACIÓN
20	372451A1	PRIMO SFILO	FIRST EXTENSION BOOM	PREMIÈRE PROLONGATION	ERSTE ERWEITERUNG	PRIMERA PRÓRROGA
20	372451A3	PRIMO SFILO	FIRST EXTENSION BOOM	PREMIÈRE PROLONGATION	ERSTE ERWEITERUNG	PRIMERA PRÓRROGA
20	372451A5	PRIMO SFILO	FIRST EXTENSION BOOM	PREMIER EXTENSION	ERSTE ERWEITERUNG	PRIMERA EXTENSION
20	372451A6	PRIMO SFILO	FIRST EXTENSION BOOM	PREMIÈRE PROLONGATION	ERSTE ERWEITERUNG	PRIMERA PRÓRROGA



Main color codes:  J1 - JLG Cream,  J2 - JLG Orange,  C4 - Green



 PRIMO SFILO
 FIRST EXTENSION ARM
 PREMIER BRAS D'EXTRACTION

ERSTER TELESKOPARM 
 PRIMO BRAZO DE EXTENSION 



POS	Codice	 Descrizione	 Description	 Designation	 Benennung	 Descripción
20	372451A7	PRIMO SFILO	FIRST EXTENSION BOOM	PREMIER EXTENSION	ERSTE ERWEITERUNG	PRIMERA EXTENSION
20	372451A8	PRIMO SFILO	FIRST EXTENSION BOOM	PREMIÈRE PROLONGATION	ERSTE ERWEITERUNG	PRIMERA PRÓRROGA
20	372451A9	PRIMO SFILO	FIRST EXTENSION BOOM	PREMIÈRE PROLONGATION	ERSTE ERWEITERUNG	PRIMERA PRÓRROGA
20	372451AG	PRIMO SFILO	FIRST EXTENSION BOOM	PREMIÈRE PROLONGATION	ERSTE ERWEITERUNG	PRIMERA AMPLIACIÓN
20	372451B1	PRIMO SFILO	FIRST EXTENSION BOOM	PREMIÈRE PROLONGATION	ERSTE ERWEITERUNG	PRIMERA PRÓRROGA
20	372451BA	PRIMO SFILO	FIRST EXTENSION BOOM	PREMIÈRE PROLONGATION	ERSTE ERWEITERUNG	PRIMERA PRÓRROGA
20	372451BC	PRIMO SFILO	FIRST EXTENSION BOOM	PREMIÈRE PROLONGATION	ERSTE ERWEITERUNG	PRIMERA PRÓRROGA
20	372451BP	PRIMO SFILO	FIRST EXTENSION BOOM	PREMIER EXTENSION	ERSTE ERWEITERUNG	PRIMERA EXTENSION
20	372451C4	PRIMO SFILO	FIRST EXTENSION BOOM	PREMIÈRE PROLONGATION	ERSTE ERWEITERUNG	PRIMERA PRÓRROGA
20	372451CL	PRIMO SFILO	FIRST EXTENSION BOOM	PREMIÈRE PROLONGATION	ERSTE ERWEITERUNG	PRIMERA AMPLIACIÓN
20	372451CO	PRIMO SFILO	FIRST EXTENSION BOOM	PREMIÈRE PROLONGATION	ERSTE ERWEITERUNG	PRIMERA PRÓRROGA
20	372451D4	PRIMO SFILO	FIRST EXTENSION BOOM	PREMIÈRE PROLONGATION	ERSTE ERWEITERUNG	PRIMERA PRÓRROGA
20	372451DI	PRIMO SFILO	FIRST EXTENSION BOOM	PREMIÈRE PROLONGATION	ERSTE ERWEITERUNG	PRIMERA PRÓRROGA
20	372451FX	PRIMO SFILO	FIRST EXTENSION BOOM	PREMIER EXTENSION	ERSTE ERWEITERUNG	PRIMERA EXTENSION
20	372451GB	PRIMO SFILO	FIRST EXTENSION BOOM	PREMIÈRE PROLONGATION	ERSTE ERWEITERUNG	PRIMERA PRÓRROGA
20	372451H1	PRIMO SFILO	FIRST EXTENSION BOOM	PREMIÈRE PROLONGATION	ERSTE ERWEITERUNG	PRIMERA AMPLIACIÓN
20	372451H3	PRIMO SFILO	FIRST EXTENSION BOOM	PREMIÈRE PROLONGATION	ERSTE ERWEITERUNG	PRIMERA PRÓRROGA



Main color codes:  J1 - JLG Cream,  J2 - JLG Orange,  C4 - Green



 PRIMO SFILO
 FIRST EXTENSION ARM
 PREMIER BRAS D'EXTRACTION



ERSTER TELESKOPARM 
 PRIMO BRAZO DE EXTENSION 



POS	Codice	 Descrizione	 Description	 Designation	 Benennung	 Descripción
20	372451J2	PRIMO SFILO	FIRST EXTENSION BOOM	PREMIÈRE PROLONGATION	ERSTE ERWEITERUNG	PRIMERA AMPLIACIÓN
21	07248800	SPAZZOLA VERTICALE TERZO BRACCIO	VERTICAL BRUSH THIRD ARM	BRAS DE LA BROUSSE TROISIÈME	DRITTE BÜRSTE ARM	TERCER CEPILLO ARM
22	07249000	PROFILO FISSAGGIO SPAZZOLE TERZO BRACCIO	PROFILE FITTING BRUSH THIRD BOOM	FIXATION DU BRAS DE BALAI TROISIÈME	BEFESTIGUNG DIE DRITTE BÜRSTE ARM	FIJACIÓN DEL CEPILLO TERCER BRAZO
23	07248600	SPAZZOLA SUPERIORE TERZO BRACCIO	BRUSH TOP THIRD ARM	BRAS DE LA BROUSSE TROISIÈME	DRITTE BÜRSTE ARM	TERCER CEPILLO ARM
24	07248900	PIEGATO FISSAGGIO SPAZZOLE TERZO BRACCIO	THIRD ARM FIXING FOLDED BRUSH	FIXATION DU BRAS DE BALAI TROISIÈME	BEFESTIGUNG DIE DRITTE BÜRSTE ARM	FIJACIÓN DEL CEPILLO TERCER BRAZO
26	07248200	PIEGATO FISSAGGIO SPAZZOLE PRIMO SFILO	FIXING FOLDED BRUSH FIRST EXTENSION	FIXATION DES BROUSSES	BEFESTIGUNG BRUSHES	FIJACIÓN DE LOS CEPILLOS
27	07248300	PROFILO FISSAGGIO SPAZZOLE PRIMO SFILO	PROFILE FITTING BRUSH FIRST EXTENSION	FIXATION DES BROUSSES	BEFESTIGUNG BRUSHES	FIJACIÓN DE LOS CEPILLOS
28	07248400	SPAZZOLA ORIZZONTALE PRIMO SFILO	HORIZONTAL BRUSH FIRST EXTENSION	BROSSE PREMIERE EXTENSION	BRUSH ERSTE ERWEITERUNG	CEPILLO PRIMERA EXTENSIÓN
29	07248500	SPAZZOLA VERTICALE PRIMO SFILO	VERTICAL BRUSH FIRST EXTENSION	BROSSE PREMIERE EXTENSION	BRUSH ERSTE ERWEITERUNG	CEPILLO PRIMERA EXTENSIÓN
31	07248700	SPAZZOLA INFERIORE TERZO BRACCIO	LOWER BRUSH THIRD BOOM	BRAS DE LA BROUSSE TROISIÈME	DRITTE BÜRSTE ARM	TERCER CEPILLO ARM
32	07246800	PATTINO IN PLASTICA	SLIDE BLOCK	PATIN	GLEITELEMENT	PATIN
33	17248500	KIT SPAZZOLE PRIMO SFILO LL2010	BRUSHES KIT	KIT BROUSSES	BÜRSTENSATZ	KIT CEPILLOS
35	17248800	KIT SPAZZOLE TERZO BRACCIO LL2010	BRUSHES KIT	KIT BROUSSES	BÜRSTENSATZ	KIT CEPILLOS



Main color codes:  J1 - JLG Cream,  J2 - JLG Orange,  C4 - Green

 PRIMO SFILO
 FIRST EXTENSION ARM
 PREMIER BRAS D'EXTRACTION



ERSTER TELESKOPARM 
PRIMO BRAZO DE EXTENSION 



Main color codes:  **J1** - JLG Cream,  **J2** - JLG Orange,  **C4** - Green

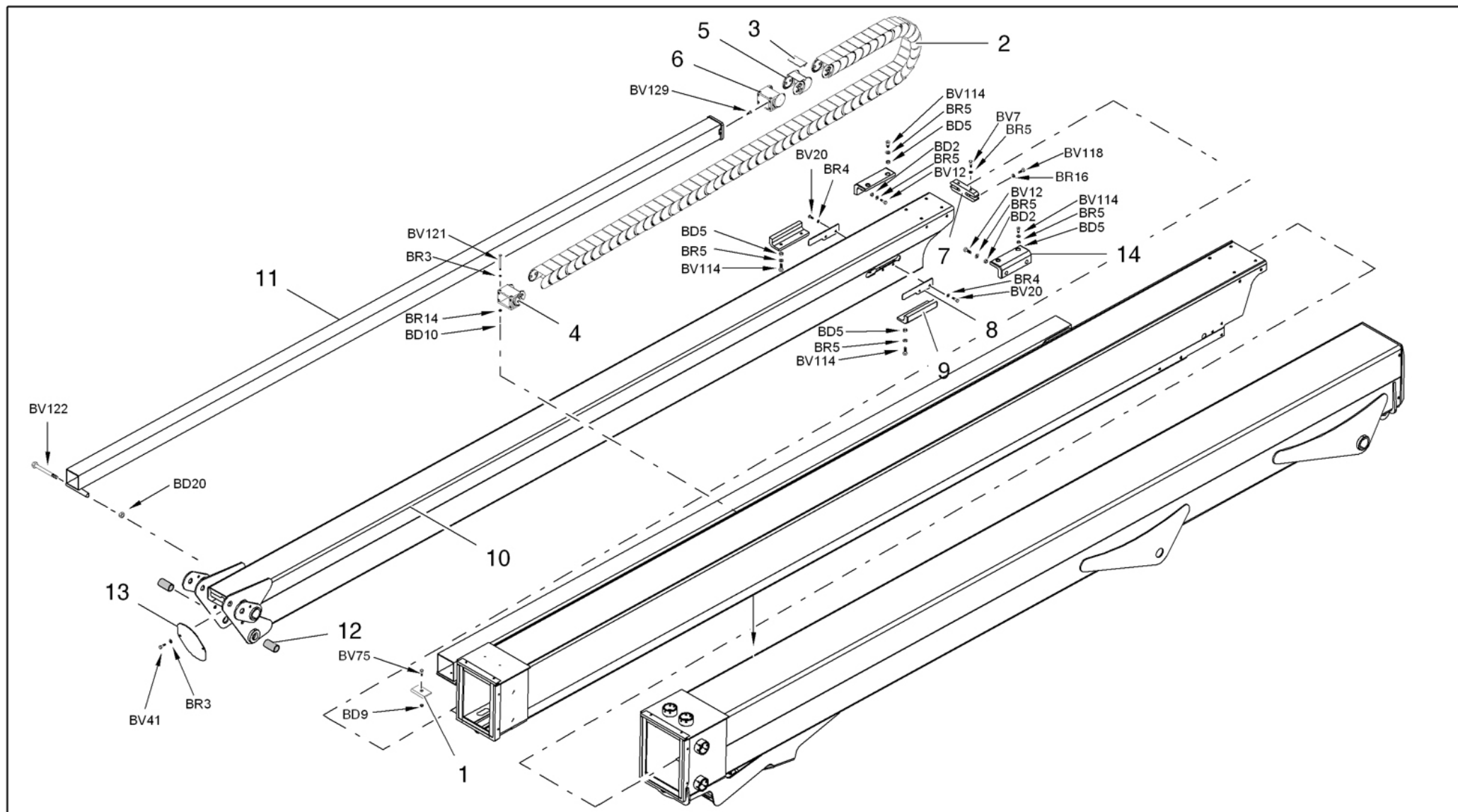

-  SECONDO SFILÒ
-  SECONDO EXTENSION ARM
-  DEUXIÈME BRAS D'EXTRACTION





ZWEITER TELESKOPARM 
 SEGUNDO BRAZO TELESCÓPICO 









Main color codes:  J1 - JLG Cream,  J2 - JLG Orange,  C4 - Green



 SECONDO SFILO
 SECONDO EXTENSION ARM
 DEUXIÈME BRAS D'EXTRACTION





ZWEITER TELESKOPARM 
 SEGUNDO BRAZO TELESCÓPICO 



POS	Codice	 Descrizione	 Description	 Designation	 Benennung	 Descripción
1	06586300	PATTINO	SLIDE BLOCK	PATIN	GLEITBLOCK	PATÍN
2	27247900	CATENA PORTACAVI	CABLE-HOLDER CHAIN	CHAÎNE PORTE-CÂBLES	KABELHALTERKETTE	CADENA PORTACABLES
3	2646160001	COPERCHIO CATENA PORTACAVI	COVER CABLE-HOLDER CHAIN	COUVERCLE	DECKEL	TAPA
4	2646160002	ATTACCO FEMMINA CATENA PORTACAVI	FEMALE COUPLING CABLE-HOLDER CHAIN	RACCORD FEMELLE	AUFSTECKANSCHLUSS	EMPALME HEMBRA
5	2646160003	MAGLIA CATENA PORTACAVI	CABLE-HOLDER CHAIN LINK	MAILLOT CHAÎNE	KETTENGLIED	ESLABÓN CADENA
6	2646160004	ATTACCO MASCHIO CATENA PORTACAVI	MALE COUPLING CABLE-HOLDER CHAIN	RACCORD MÂLE	STECKANSCHLUSS	EMPALME MACHO
7	062962Y2	PIASTRA	PLATE	PLATINE	PLATTE	PLACA
8	062967Y1	COPERCHIO	COVER	COUVERCLE	DECKEL	TAPA
9	07246600	PATTINO IN PLASTICA	SLIDE BLOCK	PLASTIQUE DE CHAUSSURE	SCHUH KUNSTSTOFF	PLÁSTICO DE ZAPATOS
10	172267A1	SECONDO SFILO	SECOND EXTENSION ARM	SECOND BRAS D'EXTRACTION	ZWEITER TELESKOPARM	SEGUNDO BRAZO DE EXTENSIÓN
10	172267A3	SECONDO SFILO	SECOND EXTENSION ARM	SECOND BRAS D'EXTRACTION	ZWEITER TELESKOPARM	SEGUNDO BRAZO DE EXTENSIÓN
10	172267A5	SECONDO SFILO	SECOND EXTENSION ARM	SECOND BRAS D'EXTRACTION	ZWEITER TELESKOPARM	SEGUNDO BRAZO DE EXTENSIÓN
10	172267A6	SECONDO SFILO	SECOND EXTENSION ARM	SECOND BRAS D'EXTRACTION	ZWEITER TELESKOPARM	SEGUNDO BRAZO DE EXTENSIÓN
10	172267A7	SECONDO SFILO	SECOND EXTENSION ARM	SECOND BRAS D'EXTRACTION	ZWEITER TELESKOPARM	SEGUNDO BRAZO DE EXTENSIÓN
10	172267A8	SECONDO SFILO	SECOND EXTENSION ARM	SECOND BRAS D'EXTRACTION	ZWEITER TELESKOPARM	SEGUNDO BRAZO DE EXTENSIÓN
10	172267A9	SECONDO SFILO	SECOND EXTENSION ARM	SECOND BRAS D'EXTRACTION	ZWEITER TELESKOPARM	SEGUNDO BRAZO DE EXTENSIÓN
10	172267AG	SECONDO SFILO	SECOND EXTENSION ARM	SECOND BRAS D'EXTRACTION	ZWEITER TELESKOPARM	SEGUNDO BRAZO DE EXTENSIÓN



Main color codes:  J1 - JLG Cream,  J2 - JLG Orange,  C4 - Green



 SECONDO SFILO
 SECONDO EXTENSION ARM
 DEUXIÈME BRAS D'EXTRACTION

ZWEITER TELESKOPARM 
 SEGUNDO BRAZO TELESCÓPICO 



POS	Codice	 Descrizione	 Description	 Designation	 Benennung	 Descripción
10	172267B1	SECONDO SFILO	SECOND EXTENSION ARM	SECOND BRAS D'EXTRACTION	ZWEITER TELESKOPARM	SEGUNDO BRAZO DE EXTENSIÓN
10	172267BA	SECONDO SFILO	SECOND EXTENSION ARM	SECOND BRAS D'EXTRACTION	ZWEITER TELESKOPARM	SEGUNDO BRAZO DE EXTENSIÓN
10	172267BC	SECONDO SFILO	SECOND EXTENSION ARM	SECOND BRAS D'EXTRACTION	ZWEITER TELESKOPARM	SEGUNDO BRAZO DE EXTENSIÓN
10	172267BP	SECONDO SFILO	SECOND EXTENSION ARM	SECOND BRAS D'EXTRACTION	ZWEITER TELESKOPARM	SEGUNDO BRAZO DE EXTENSIÓN
10	172267C4	SECONDO SFILO	SECOND EXTENSION ARM	SECOND BRAS D'EXTRACTION	ZWEITER TELESKOPARM	SEGUNDO BRAZO DE EXTENSIÓN
10	172267CL	SECONDO SFILO	SECOND EXTENSION ARM	SECOND BRAS D'EXTRACTION	ZWEITER TELESKOPARM	SEGUNDO BRAZO DE EXTENSIÓN
10	172267CO	SECONDO SFILO	SECOND EXTENSION ARM	SECOND BRAS D'EXTRACTION	ZWEITER TELESKOPARM	SEGUNDO BRAZO DE EXTENSIÓN
10	172267D4	SECONDO SFILO	SECOND EXTENSION ARM	SECOND BRAS D'EXTRACTION	ZWEITER TELESKOPARM	SEGUNDO BRAZO DE EXTENSIÓN
10	172267DI	SECONDO SFILO	SECOND EXTENSION ARM	SECOND BRAS D'EXTRACTION	ZWEITER TELESKOPARM	SEGUNDO BRAZO DE EXTENSIÓN
10	172267FX	SECONDO SFILO	SECOND EXTENSION ARM	SECOND BRAS D'EXTRACTION	ZWEITER TELESKOPARM	SEGUNDO BRAZO DE EXTENSIÓN
10	172267GB	SECONDO SFILO	SECOND EXTENSION ARM	SECOND BRAS D'EXTRACTION	ZWEITER TELESKOPARM	SEGUNDO BRAZO DE EXTENSIÓN
10	172267H1	SECONDO SFILO	SECOND EXTENSION ARM	SECOND BRAS D'EXTRACTION	ZWEITER TELESKOPARM	SEGUNDO BRAZO DE EXTENSIÓN
10	172267H3	SECONDO SFILO	SECOND EXTENSION ARM	SECOND BRAS D'EXTRACTION	ZWEITER TELESKOPARM	SEGUNDO BRAZO DE EXTENSIÓN
10	172267J2	SECONDO SFILO	SECOND EXTENSION ARM	SECOND BRAS D'EXTRACTION	ZWEITER TELESKOPARM	SEGUNDO BRAZO DE EXTENSIÓN
11	372478H3	SUPPORTO CATENARIA SU SECONDO SFILO	SUPPORT CABLE HOLDER CHAIN ON SECOND EXTENSION BOOM	APPUI AERIEN SUR SECONDE EXTENSION	OBENLIEGENDE SUPPORT ON ZWEITE VERLÄNGERUNG	APOYO SUPERIOR EN SEGUNDA AMPLIACIÓN
12	06900700	BOCCOLA	BUSH	DOUILLE	BUCHSE	CASQUILLO
13	072842H3	COPERCHIO	COVER	COUVERTURE	DECKUNG	COBERTURA



Main color codes:  J1 - JLG Cream,  J2 - JLG Orange,  C4 - Green

 SECONDO SFILO
 SECONDO EXTENSION ARM
 DEUXIÈME BRAS D'EXTRACTION



ZWEITER TELESKOPARM 
 SEGUNDO BRAZO TELESCÓPICO 

POS	Codice	 Descrizione	 Description	 Designation	 Benennung	 Descripción
14	07246500	PATTINO IN PLASTICA	SLIDE BLOCK	PLASTIQUE DE CHAUSSURE	SCHUH KUNSTSTOFF	PLÁSTICO DE ZAPATOS

 SUPPORTO CESTO
 BASKET SUPPORT
 PANIER CUPPORT

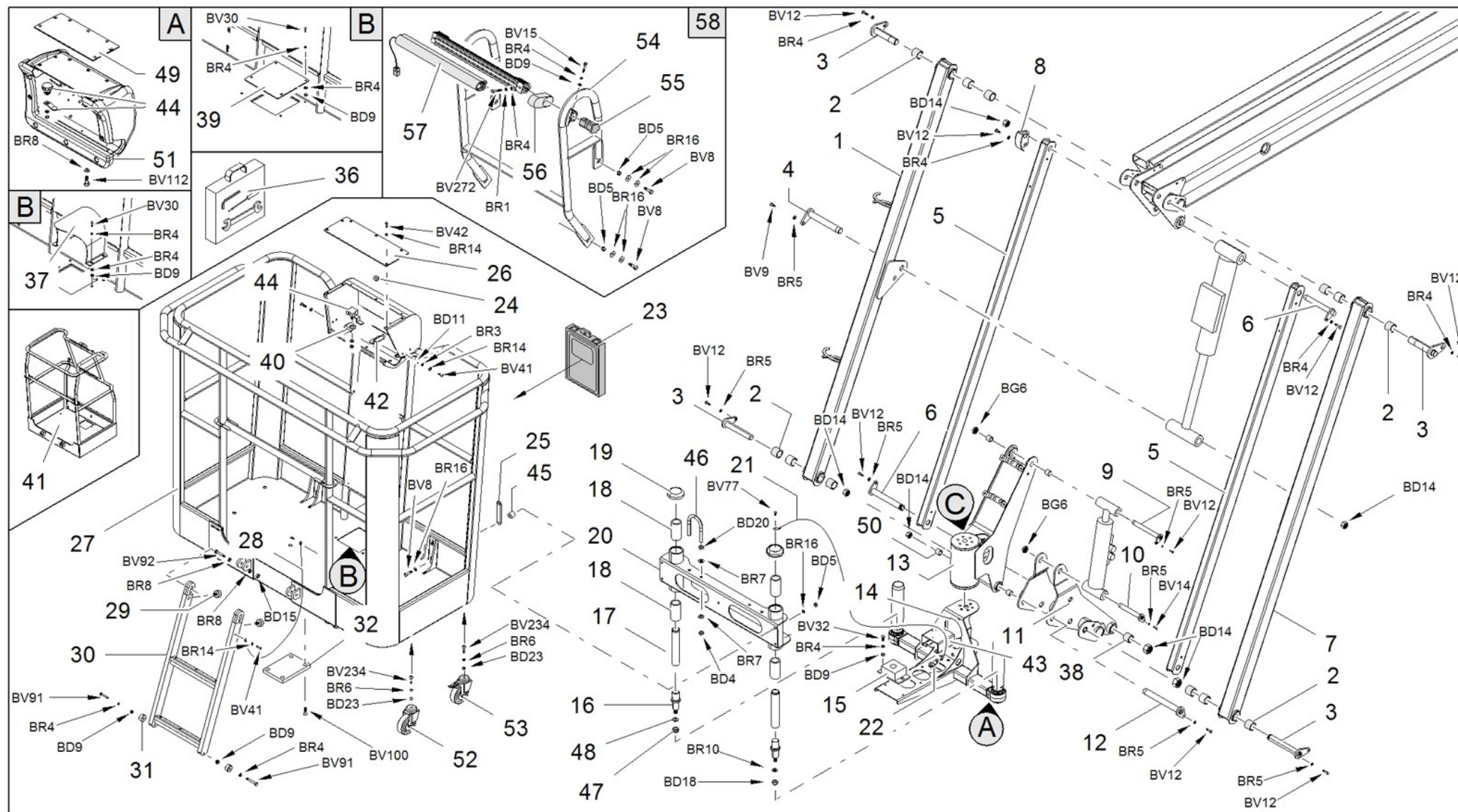
HALTERUNG ARBEITSKORB 
 SOPORTE CESTA 









Main color codes:  J1 - JLG Cream,  J2 - JLG Orange,  C4 - Green

 SUPPORTO CESTO

 BASKET SUPPORT

 PANIER CUPPORT
HALTERUNG ARBEITSKORB SOPORTE CESTA 

POS	Codice	 Descrizione	 Description	 Designation	 Benennung	 Descripción
1	170947A1	BRACCIO JIB COMPLETO	COMPLETE JIB ARM	FLÉCHETTE BRAS COMPLÈTE	ARM - SCHWENKARM	BRAZO JIB COMPLETO
1	170947A3	BRACCIO JIB COMPLETO	COMPLETE JIB ARM	FLÉCHETTE BRAS COMPLÈTE	ARM - SCHWENKARM	BRAZO JIB COMPLETO
1	170947A5	BRACCIO JIB COMPLETO	COMPLETE JIB ARM	FLÉCHETTE BRAS COMPLÈTE	ARM - SCHWENKARM	BRAZO JIB COMPLETO
1	170947A6	BRACCIO JIB COMPLETO	COMPLETE JIB ARM	FLÉCHETTE BRAS COMPLÈTE	ARM - SCHWENKARM	BRAZO JIB COMPLETO
1	170947A7	BRACCIO JIB COMPLETO	COMPLETE JIB ARM	FLÉCHETTE BRAS COMPLÈTE	ARM - SCHWENKARM	BRAZO JIB COMPLETO
1	170947A8	BRACCIO JIB COMPLETO	COMPLETE JIB ARM	FLÉCHETTE BRAS COMPLÈTE	ARM - SCHWENKARM	BRAZO JIB COMPLETO
1	170947A9	BRACCIO JIB COMPLETO	COMPLETE JIB ARM	FLÉCHETTE BRAS COMPLÈTE	ARM - SCHWENKARM	BRAZO JIB COMPLETO
1	170947AG	BRACCIO JIB COMPLETO SX	COMPLETE JIB ARM LEFT	BRAS JIB GAUCHE	KORBARM LINKS	BRAZO JIB IZQUIERDA
1	170947B1	BRACCIO JIB COMPLETO	COMPLETE JIB ARM	FLÉCHETTE BRAS COMPLÈTE	ARM - SCHWENKARM	BRAZO JIB COMPLETO
1	170947BA	BRACCIO JIB COMPLETO	COMPLETE JIB ARM	FLÉCHETTE BRAS COMPLÈTE	ARM - SCHWENKARM	BRAZO JIB COMPLETO
1	170947BC	BRACCIO JIB COMPLETO	COMPLETE JIB ARM	FLÉCHETTE BRAS COMPLÈTE	ARM - SCHWENKARM	BRAZO JIB COMPLETO
1	170947BP	BRACCIO JIB COMPLETO	COMPLETE JIB ARM	FLÉCHETTE BRAS COMPLÈTE	ARM - SCHWENKARM	BRAZO JIB COMPLETO
1	170947C4	BRACCIO JIB COMPLETO	COMPLETE JIB ARM	FLÉCHETTE BRAS COMPLÈTE	ARM - SCHWENKARM	BRAZO JIB COMPLETO
1	170947CL	BRACCIO JIB COMPLETO SX	COMPLETE JIB ARM LEFT	BRAS JIB GAUCHE	KORBARM LINKS	BRAZO JIB IZQUIERDA
1	170947CO	BRACCIO JIB COMPLETO	COMPLETE JIB ARM	FLÉCHETTE BRAS COMPLÈTE	ARM - SCHWENKARM	BRAZO JIB COMPLETO
1	170947D4	BRACCIO JIB COMPLETO	COMPLETE JIB ARM	FLÉCHETTE BRAS COMPLÈTE	ARM - SCHWENKARM	BRAZO JIB COMPLETO
1	170947DI	BRACCIO JIB COMPLETO	COMPLETE JIB ARM	FLÉCHETTE BRAS COMPLÈTE	ARM - SCHWENKARM	BRAZO JIB COMPLETO

Main color codes:  J1 - JLG Cream,  J2 - JLG Orange,  C4 - Green





 SUPPORTO CESTO



 BASKET SUPPORT

 PANIER CUPPORT

 HALTERUNG ARBEITSKORB

 SOPORTE CESTA

POS	Codice	 Descrizione	 Description	 Designation	 Benennung	 Descripción
1	170947FX	BRACCIO JIB COMPLETO	COMPLETE JIB ARM	FLÉCHETTE BRAS COMPLÈTE	ARM - SCHWENKARM	BRAZO JIB COMPLETO
1	170947GB	BRACCIO JIB COMPLETO	COMPLETE JIB ARM	FLÉCHETTE BRAS COMPLÈTE	ARM - SCHWENKARM	BRAZO JIB COMPLETO
1	170947H1	BRACCIO JIB COMPLETO	COMPLETE JIB ARM	FLÉCHETTE BRAS COMPLÈTE	ARM - SCHWENKARM	BRAZO JIB COMPLETO
1	170947H3	BRACCIO JIB COMPLETO	COMPLETE JIB ARM	FLÉCHETTE BRAS COMPLÈTE	ARM - SCHWENKARM	BRAZO JIB COMPLETO
1	170947J2	BRACCIO JIB COMPLETO SX	COMPLETE JIB ARM LEFT	BRAS JIB GAUCHE	KORBARM LINKS	BRAZO JIB IZQUIERDA
2	06272600	BOCCOLA	BUSH	DOUILLE	BUCHSE	CASQUILLO
3	07093500	SPINA	PIN	CHEVILLE	STIFT	CLAVIJA
4	07093800	SPINA	PIN	CHEVILLE	STIFT	CLAVIJA
5	359447A1	TIRANTE	TIE ROD	TIRANT	TURMGESTÄNGE	TIRANTE
5	359447A3	TIRANTE	TIE ROD	TIRANT	TURMGESTÄNGE	TIRANTE
5	359447A5	TIRANTE	TIE ROD	TIRANT	TURMGESTÄNGE	TIRANTE
5	359447A6	TIRANTE	TIE ROD	TIRANT	TURMGESTÄNGE	TIRANTE
5	359447A7	TIRANTE	TIE ROD	TIRANT	TURMGESTÄNGE	TIRANTE
5	359447A8	TIRANTE	TIE ROD	TIRANT	TURMGESTÄNGE	TIRANTE
5	359447A9	TIRANTE	TIE ROD	TIRANT	TURMGESTÄNGE	TIRANTE
5	359447AG	TIRANTE JIB	TIE ROD JIB	TIRANT	ZUGSTANGE	TIRANTE
5	359447B1	TIRANTE	TIE ROD	TIRANT	TURMGESTÄNGE	TIRANTE
5	359447BA	TIRANTE	TIE ROD	TIRANT	TURMGESTÄNGE	TIRANTE
5	359447BC	TIRANTE	TIE ROD	TIRANT	TURMGESTÄNGE	TIRANTE
5	359447BP	TIRANTE	TIE ROD	TIRANT	TURMGESTÄNGE	TIRANTE
5	359447C4	TIRANTE	TIE ROD	TIRANT	TURMGESTÄNGE	TIRANTE
5	359447CL	TIRANTE JIB	TIE ROD JIB	TIRANT	ZUGSTANGE	TIRANTE
5	359447CO	TIRANTE	TIE ROD	TIRANT	TURMGESTÄNGE	TIRANTE
5	359447D4	TIRANTE	TIE ROD	TIRANT	TURMGESTÄNGE	TIRANTE
5	359447DI	TIRANTE	TIE ROD	TIRANT	TURMGESTÄNGE	TIRANTE
5	359447FX	TIRANTE	TIE ROD	TIRANT	TURMGESTÄNGE	TIRANTE
5	359447H1	TIRANTE	TIE ROD	TIRANT	TURMGESTÄNGE	TIRANTE
5	359447H3	TIRANTE	TIE ROD	TIRANT	TURMGESTÄNGE	TIRANTE



Main color codes:  J1 - JLG Cream,  J2 - JLG Orange,  C4 - Green

 SUPPORTO CESTO

 BASKET SUPPORT

 PANIER CUPPORT
HALTERUNG ARBEITSKORB SOPORTE CESTA 





POS	Codice	 Descrizione	 Description	 Designation	 Benennung	 Descripción
5	359447J2	TIRANTE JIB	TIE ROD JIB	TIRANT	ZUGSTANGE	TIRANTE
6	07093600	SPINA	PIN	CHEVILLE	STIFT	CLAVIJA
7	170948A1	BRACCIO JIB COMPLETO	COMPLETE JIB ARM	FLÉCHETTE BRAS COMPLÈTE	ARM - SCHWENKARM	BRAZO JIB COMPLETO
7	170948A3	BRACCIO JIB COMPLETO	COMPLETE JIB ARM	FLÉCHETTE BRAS COMPLÈTE	ARM - SCHWENKARM	BRAZO JIB COMPLETO
7	170948A5	BRACCIO JIB COMPLETO	COMPLETE JIB ARM	FLÉCHETTE BRAS COMPLÈTE	ARM - SCHWENKARM	BRAZO JIB COMPLETO
7	170948A6	BRACCIO JIB COMPLETO	COMPLETE JIB ARM	FLÉCHETTE BRAS COMPLÈTE	ARM - SCHWENKARM	BRAZO JIB COMPLETO
7	170948A7	BRACCIO JIB COMPLETO	COMPLETE JIB ARM	FLÉCHETTE BRAS COMPLÈTE	ARM - SCHWENKARM	BRAZO JIB COMPLETO
7	170948A8	BRACCIO JIB COMPLETO	COMPLETE JIB ARM	FLÉCHETTE BRAS COMPLÈTE	ARM - SCHWENKARM	BRAZO JIB COMPLETO
7	170948A9	BRACCIO JIB COMPLETO	COMPLETE JIB ARM	FLÉCHETTE BRAS COMPLÈTE	ARM - SCHWENKARM	BRAZO JIB COMPLETO
7	170948AG	BRACCIO JIB COMPLETO DX	COMPLETE JIB ARM RIGHT	BRAS JIB DROITE COMPLÈTE	KORBARM RECHTS	BRAZO JIB DERECHA COMPLETO
7	170948B1	BRACCIO JIB COMPLETO	COMPLETE JIB ARM	FLÉCHETTE BRAS COMPLÈTE	ARM - SCHWENKARM	BRAZO JIB COMPLETO
7	170948BA	BRACCIO JIB COMPLETO	COMPLETE JIB ARM	FLÉCHETTE BRAS COMPLÈTE	ARM - SCHWENKARM	BRAZO JIB COMPLETO
7	170948BC	BRACCIO JIB COMPLETO	COMPLETE JIB ARM	FLÉCHETTE BRAS COMPLÈTE	ARM - SCHWENKARM	BRAZO JIB COMPLETO
7	170948BP	BRACCIO JIB COMPLETO	COMPLETE JIB ARM	FLÉCHETTE BRAS COMPLÈTE	ARM - SCHWENKARM	BRAZO JIB COMPLETO
7	170948C4	BRACCIO JIB COMPLETO	COMPLETE JIB ARM	FLÉCHETTE BRAS COMPLÈTE	ARM - SCHWENKARM	BRAZO JIB COMPLETO
7	170948CL	BRACCIO JIB COMPLETO DX	COMPLETE JIB ARM RIGHT	BRAS JIB DROITE COMPLÈTE	KORBARM RECHTS	BRAZO JIB DERECHA COMPLETO
7	170948CO	BRACCIO JIB COMPLETO	COMPLETE JIB ARM	FLÉCHETTE BRAS COMPLÈTE	ARM - SCHWENKARM	BRAZO JIB COMPLETO
7	170948D4	BRACCIO JIB COMPLETO	COMPLETE JIB ARM	FLÉCHETTE BRAS COMPLÈTE	ARM - SCHWENKARM	BRAZO JIB COMPLETO



Main color codes:  J1 - JLG Cream,  J2 - JLG Orange,  C4 - Green

 SUPPORTO CESTO

 BASKET SUPPORT

 PANIER CUPPORT
HALTERUNG ARBEITSKORB SOPORTE CESTA 





POS	Codice	 Descrizione	 Description	 Designation	 Benennung	 Descripción
7	170948DI	BRACCIO JIB COMPLETO	COMPLETE JIB ARM	FLÉCHETTE BRAS COMPLÈTE	ARM - SCHWENKARM	BRAZO JIB COMPLETO
7	170948FX	BRACCIO JIB COMPLETO	COMPLETE JIB ARM	FLÉCHETTE BRAS COMPLÈTE	ARM - SCHWENKARM	BRAZO JIB COMPLETO
7	170948GB	BRACCIO JIB COMPLETO	COMPLETE JIB ARM	FLÉCHETTE BRAS COMPLÈTE	ARM - SCHWENKARM	BRAZO JIB COMPLETO
7	170948H1	BRACCIO JIB COMPLETO	COMPLETE JIB ARM	FLÉCHETTE BRAS COMPLÈTE	ARM - SCHWENKARM	BRAZO JIB COMPLETO
7	170948H3	BRACCIO JIB COMPLETO	COMPLETE JIB ARM	FLÉCHETTE BRAS COMPLÈTE	ARM - SCHWENKARM	BRAZO JIB COMPLETO
7	170948J2	BRACCIO JIB COMPLETO DX	COMPLETE JIB ARM RIGHT	BRAS JIB DROITE COMPLÈTE	KORBARM RECHTS	BRAZO JIB DERECHA COMPLETO
8	372264H3	CAMMA MICRO JIB	MICROSWITCH CAM JIB	CAME	NOCKEN	LEVA
9	07093700	SPINA	PIN	CHEVILLE	STIFT	CLAVIJA
10	06235600	SPINA	PIN	CHEVILLE	STIFT	CLAVIJA
11	166242A1	RINVIO	TRANSMISSION	RENVOI	VORGELEGE	REENVIO
11	166242A3	RINVIO	TRANSMISSION	RENVOI	VORGELEGE	REENVIO
11	166242A5	RINVIO	TRANSMISSION	RENVOI	VORGELEGE	REENVIO
11	166242A6	RINVIO	TRANSMISSION	RENVOI	VORGELEGE	REENVIO
11	166242A7	RINVIO	TRANSMISSION	RENVOI	VORGELEGE	REENVIO
11	166242A8	RINVIO	TRANSMISSION	RENVOI	VORGELEGE	REENVIO
11	166242A9	RINVIO	TRANSMISSION	RENVOI	VORGELEGE	REENVIO
11	166242AG	RINVIO JIB	UPRIGHT JIB	RENVOI	VORGELEGE	REENVIO
11	166242B1	RINVIO	TRANSMISSION	RENVOI	VORGELEGE	REENVIO
11	166242BA	RINVIO	TRANSMISSION	RENVOI	VORGELEGE	REENVIO
11	166242BC	RINVIO	TRANSMISSION	RENVOI	VORGELEGE	REENVIO
11	166242BP	RINVIO	TRANSMISSION	RENVOI	VORGELEGE	REENVIO
11	166242C4	RINVIO	TRANSMISSION	RENVOI	VORGELEGE	REENVIO
11	166242CL	RINVIO JIB	UPRIGHT JIB	RENVOI	VORGELEGE	REENVIO
11	166242CO	RINVIO	TRANSMISSION	RENVOI	VORGELEGE	REENVIO
11	166242D4	RINVIO	TRANSMISSION	RENVOI	VORGELEGE	REENVIO
11	166242DI	RINVIO	TRANSMISSION	RENVOI	VORGELEGE	REENVIO



Main color codes:  J1 - JLG Cream,  J2 - JLG Orange,  C4 - Green

 SUPPORTO CESTO

 BASKET SUPPORT

 PANIER CUPPORT
HALTERUNG ARBEITSKORB SOPORTE CESTA 





POS	Codice	 Descrizione	 Description	 Designation	 Benennung	 Descripción
11	166242FX	RINVIO	TRANSMISSION	RENGVOI	VORGELEGE	REENVIO
11	166242GB	RINVIO	TRANSMISSION	RENGVOI	VORGELEGE	REENVIO
11	166242H1	RINVIO	TRANSMISSION	RENGVOI	VORGELEGE	REENVIO
11	166242H3	RINVIO	TRANSMISSION	RENGVOI	VORGELEGE	REENVIO
11	166242J2	RINVIO JIB	UPRIGHT JIB	RENGVOI	VORGELEGE	REENVIO
12	06235700	SPINA	PIN	CHEVILLE	STIFT	CLAVIJA
13	2648910002	KIT GUARNIZIONI	SEAL KIT	KIT DE JOINTS	DICHTUNGSSATZ	KIT DE JUNTAS
13	271778A1	MOTORE DI ROTAZIONE	ROTARY MOTOR	MOTEUR DE ROTATION	MOTORDREHZAHL	MOTOR ROTACIÓN
13	271778A6	ATTUATORE ROTANTE	ROTARY MOTOR	ROTARY ACTUATOR	SCHWENKEINHEIT	ACTUADOR ROTATIVO
13	271778B1	ATTUATORE ROTANTE	ROTARY MOTOR	ROTARY ACTUATOR	SCHWENKEINHEIT	ACTUADOR ROTATIVO
13	271778BP	MOTORE DI ROTAZIONE	ROTARY MOTOR	MOTEUR DE ROTATION	MOTORDREHZAHL	MOTOR ROTACIÓN
13	271778C4	ATTUATORE ROTANTE	ROTARY MOTOR	ROTARY ACTUATOR	SCHWENKEINHEIT	ACTUADOR ROTATIVO
13	271778D4	MOTORE DI ROTAZIONE	ROTARY MOTOR	MOTEUR DE ROTATION	MOTORDREHZAHL	MOTOR ROTACIÓN
13	271778H2	MOTORE DI ROTAZIONE	ROTARY MOTOR	MOTEUR DE ROTATION	DREHANTRIEB	MOTOR ROTACIÓN
13	271778J0	MOTORE DI ROTAZIONE	ROTARY MOTOR	MOTEUR DE ROTATION	ROTATIONSMOTOR	MOTOR DE ROTACIÓN
14	371463A1	ASSIEME SUPPORTO CESTO PERNI DIAM.50	TOGETHER SUPPORT PINS BASKET DIAM.50	ENSEMBLE SUPPORT PINS BASKET DIAM.50	TOGETHER AUFLAGESTIFTE BASKET DIAM.50	JUNTOS APOYO PINS CESTA DIAM.50
14	371463B1	ASSIEME SUPPORTO CESTO PERNI DIAM.50	BASKET ASSEMBLY SUPPORT PINS Ø50	ENSEMBLE SUPPORT PANIER	TOGETHER STÜTZKORBS	JUNTOS SOPORTE DE LA CESTA
14	371463BP	ASSIEME SUPPORTO CESTO PERNI DIAM.50	BASKET ASSEMBLY SUPPORT PINS Ø50	ENSEMBLE SUPPORT PANIER	TOGETHER STÜTZKORBS	JUNTOS SOPORTE DE LA CESTA
14	371463C4	ASSIEME SUPPORTO CESTO PERNI DIAM.50	BASKET ASSEMBLY SUPPORT PINS Ø50	ENSEMBLE SUPPORT PANIER	TOGETHER STÜTZKORBS	JUNTOS SOPORTE DE LA CESTA



Main color codes:  J1 - JLG Cream,  J2 - JLG Orange,  C4 - Green

 SUPPORTO CESTO

 BASKET SUPPORT

 PANIER CUPPORT
HALTERUNG ARBEITSKORB SOPORTE CESTA 

POS	Codice	 Descrizione	 Description	 Designation	 Benennung	 Descripción
14	371463D4	ASSIEME SUPPORTO CESTO PERNI DIAM.50	TOGETHER SUPPORT PINS BASKET DIAM.50	ENSEMBLE SUPPORT PINS BASKET DIAM.50	TOGETHER AUFLAGESTIFTE BASKET DIAM.50	JUNTOS APOYO PINS CESTA DIAM.50
14	371463H2	ASSIEME SUPPORTO CESTO PERNI DIAM.50	TOGETHER SUPPORT PINS BASKET DIAM.50	ENSEMBLE SUPPORT PINS BASKET DIAM.50	TOGETHER AUFLAGESTIFTE BASKET DIAM.50	JUNTOS APOYO PINS CESTA DIAM.50
14	371463J2	ASSIEME SUPPORTO CESTO PERNI DIAM.50	BASKET SUPPORT ASSEMBLY PINS Ø50	SUPPORT PANIER	KORBHALTERUNG	SOPORTE DE LA CESTA
14	377660A6	SUPPORTO CESTO	BASKET SUPPORT	SUPPORT PANIER	KORBHALTERUNG	SOPORTE CESTA
14	377660H2	SUPPORTO CESTO	BASKET SUPPORT	SUPPORT PANIER	KORBHALTERUNG	SOPORTE CESTA
14	377660Y1	SUPPORTO CESTO	BASKET SUPPORT	SUPPORT DE PANIER	KORBHALTERUNG	SOPORTE DE CESTA
15	056187H3	COPERCHIO	BOX	COUVERCLE	DECKEL	TAPA
16	07190900	VITE TE DIN960 CI 8.8 M16X1.5X115 FORATA GEOMET321 PLUS XL	TE SCREW DIN960 CI 8.8 M16X1.5X115 GEOMET321 PERFORATED PLUS XL	VIS TE DIN960 CI 8,8 M16X1.5X115 FORE PLUS GEOMET321 XL	TE SCHRAUBE DIN960 CI 8,8 M16X1.5X115 GEOMET321 PERFORATED PLUS XL	TE TORNILLO DIN960 CI 8,8 M16X1.5X115 GEOMET321 PERFORADA XL
17	07146500	PERNO SUPPORTO CESTO DIAM.50	PIN SUPPORT BASKET Ø50	AXE DIAM.50 PANIER DE SOUTIEN	BOLZEN KORBHALTERUNG	CLAVIJA CESTA
18	27146200	CUSCINETTO LINEARE A SFERE 50-100	LINEAR BALL BEARING 50-100	ROULEMENT Á BILLES	LINEAR-KUGELLAGER 50-100	COJINETE DE BOLAS 50-100
19	07146400	TAPPO CHIUSURA PERNI SUPPORTO CESTO DIAM.50	CAP PINS BASKET SUPPORT Ø50	BOUCHON	VERSCHLUSS	TAPÓN
20	371459A6	SLITTA FISSAGGIO CESTO PERNI DIAM.50	SLIDE BASKET MOUNTING BOLTS Ø50	GRILLE COULISSANTE MONTAGE	SLIDE RACKMONTAGE	PARRILLA CORREDIZA MONTAJE
20	371459H2	SLITTA FISSAGGIO CESTO PERNI DIAM.50	SLIDE BASKET MOUNTING BOLTS Ø50	COULISSEAU	SCHLITTEN	CORREDERA
20	371459Y1	SLITTA FISSAGGIO CESTO PERNI DIAM.50	SLIDE BASKET MOUNTING BOLTS Ø50	GRILLE COULISSANTE MONTAGE	SLIDE RACKMONTAGE	PARRILLA CORREDIZA MONTAJE



Main color codes:  J1 - JLG Cream,  J2 - JLG Orange,  C4 - Green

 SUPPORTO CESTO

 BASKET SUPPORT

 PANIER CUPPORT
HALTERUNG ARBEITSKORB SOPORTE CESTA 





POS	Codice	 Descrizione	 Description	 Designation	 Benennung	 Descripción
21	06665000	FUNE	CABLE	CÂBLE	SEIL	CABLE
22	07052900	STAFFA	BRACKET	ÉTRIER	HALTEBÜGEL	ESTRIBO
23	05643600	CASSETTA PORTAMANUALE	MANUAL BOX	BOÎTE PORTE- MANUEL	BEDIENUNGSANLEIT UNGSFACH	CAJA PORTAMANUAL
24	06477600	MAGNETE Ø20 CON FORO M3	MAGNETO Ø20 WITH M3 HOLE	AIMANT	MAGNET	IMÁN
25	072398H3	PIASTRA FISSAGGIO CESTO (SOLO MACCHINE MODELLO JP E JA E X17J)	FIXING PLATE BASKET (ONLY MACHINES MODEL JP AND JA AND X17J)	PLATE FIXATION DRUM	PLATE BEFESTIGUNG DRUM	PLACA FIJACIÓN TAMBOR
26	07190600	COPERTURA SUPPORTO TELECOMANDO (SOLO MACCHINE MODELLO JP E JA E X17J)	COVER SUPPORT REMOTE CONTROL (ONLY MACHINES MODEL JP AND JA AND X17J)	COUVERTURE SUPPORT DE LA TELECOMMANDE	COVER FERNBEDIENUNGS- HA LTER	CUBIERTA SOPORTE DE CONTROL REMOTO
27	27177700	CESTO BIPOSTO 230KG (SOLO MACCHINE MODELLO JP E JA)	BASKET 2 PERSON 230KG (ONLY MACHINES MODEL JP AND JA)	PANIER 2 PERSONNES	2 MANN- ARBEITSKORB	CESTA 2 PERSONAS
27	27589300	CESTO BIPOSTO 230KG PER MK2 (DA C170000893)	BASKET 2 PERSON 230KG FOR MK2 (FROM C170000893)	PANIER 2 PERSONNES POUR MK2 (FROM C170000893)	2 MANN- ARBEITSKORB FÜR MK2 (FROM C170000893)	CESTA 2 PERSONAS PARA MK2 (FROM C170000893)
27	28250000	CESTO	BASKET	PANIER POUR 2 PERSONNES	2-MANN- ARBEITSKORB	CESTA PARA DOS PERSONAS
27	28372000	CESTO MONOPOSTO LL2614 SKYLINE - NON PREDISPOSTO SKY GUARD	BASKET SINGLE SEAT LL2614 SKYLINE	PANIER MONOPLACE LL2614 SKYLINE	KORB EINZELSITZ LL2614 SKYLINE	CESTO MONOPLAZA LL2614 SKYLINE
28	06598500	FUNE	CABLE	CÂBLE	SEIL	CABLE
29	05475900	ANTIVIBRANTE	DAMPING	ANTI - VIBRANT	VIBRATIONSDÄMPFE R	ANTIVIBRANTE
30	36585800	SCALETTA	LADDER	ÉCHELLE	LEITER	ESCALERA



Main color codes:  J1 - JLG Cream,  J2 - JLG Orange,  C4 - Green

 SUPPORTO CESTO

 BASKET SUPPORT

 PANIER CUPPORT
HALTERUNG ARBEITSKORB SOPORTE CESTA 





POS	Codice	 Descrizione	 Description	 Designation	 Benennung	 Descripción
31	06585900	ROTELLINA	SMALL ROLLER	ROULETTE	RÄDCHEN	RUEDECILLA
32	058600H3	PIASTRA	PLATE	PLAQUE	PLATTE	PLACA
35	377661A6	MENSOLA SUPPORTO CELLA DI CARICO	BRACKET SUPPORT LOAD CELL	BRIDE SUPPORT CELLULE DE CHARGE	STEIGBÜGELHALTER UNG FÜRLASTÜBERWACH UNGSZELLE	BRIDA SOPORTE CELULA DE CARGA
35	377661H2	MENSOLA SUPPORTO CELLA DI CARICO	BRACKET SUPPORT LOAD CELL	BRIDE SUPPORT CELLULE DE CHARGE	STEIGBÜGELHALTER UNG FÜRLASTÜBERWACH UNGSZELLE	BRIDA SOPORTE CELULA DE CARGA
35	377661Y1	MENSOLA SUPPORTO CELLA DI CARICO	LOAD CELL SUPPORT	SUPPORT CELLULE DE CHARGE	LASTÜBERWACHUNG SZELLE HALTERUNG	SUPORTE CÉLULA DE CARGA
37	06418600	PROTEZIONE	PROTECTION	PROTECTION	SCHUTZ	PROTECCIÓN
40	071908H3	STAFFA FISSAGGIO CHIUSURA BLOCCAGGIO TELECOMANDO (SOLO MACCHINE MODELLO JP E JA E X17J)	BRACKET LOCKING REMOTE CONTROL (ONLY MACHINES MODEL JP AND JA AND X17J)	FIN DE SUPPORT DE BLOCAGE TELECOMMANDE	BRACKET END EINRASTEN FERNBEDIENUNG	SOPORTE DE FIN DE BLOQUEO DE CONTROL REMOTO
41	17668800	CESTO MONOPOSTO COMPLETO PER X17JP-X20JP	COMPLETE ONE PERSON BASKET	PANIER COMPLET UNE PERSONNE	1-MAN ARBEITSKORB KOMPLETT	CESTA 1 PERSONA
42	071905H3	PIEGATO BLOCCAGGIO TELECOMANDO (SOLO MACCHINE MODELLO JP E JA E X17J)	BENDED LOCKING REMOTE CONTROL (ONLY MACHINES MODEL JP AND JA AND X17J)	BENT BLOCAGE TELECOMMANDE	BENT EINRASTEN FERNBEDIENUNG	BENT BLOQUEO DE CONTROL REMOTO
43	072404H3	SUPPORTO PEDALE	PEDAL SUPPORT PLATE	TÔLE PLIÉE	HALTERUNG	SOPORTE

Main color codes:  J1 - JLG Cream,  J2 - JLG Orange,  C4 - Green

 SUPPORTO CESTO



 BASKET SUPPORT

 PANIER CUPPORT
HALTERUNG ARBEITSKORB SOPORTE CESTA 

POS	Codice	 Descrizione	 Description	 Designation	 Benennung	 Descripción
44	07192700	CHIUSURA A VOLANTINO CON LEVA PIEGATA (SOLO MACCHINE MODELLO JP E JA E X17J)	LOCKING WHEEL WITH BENT LEVER (ONLY MACHINES MODEL JP AND JA AND X17J)	POIGNEE DE BLOCAGE	KUGELVERSCHLUSS	POMO DE BLOQUEO
45	07239700	DISTANZIALE PER VITI M8 SUPPORTO CESTO (SOLO MACCHINE MODELLO JP E JA E X17J)	SPACER SCREW M8 SUPPORT BASKET (ONLY MACHINES MODEL JP AND JA AND X17J)	ENTRETOISE	DISTANZSTÜCK	DISTANCIADOR
46	07031800	TUBO	PIPE	TUYAU	ROHR	TUBO
47	07193000	DADO AD INTAGLI UNI5593 CI 8 M16X1.5 GEOMET321 PLUS XL	NUT M16X1.5 NOTCHES UNI5593 CI 8 GEOMET321 PLUS XL	ÉCROU UNI5593 CI 8 M16X1.5 GEOMET321 PLUS XL	MUTTER UNI5593 CI 8 M16X1.5 GEOMET321 PLUS XL	TUERCA UNI5593 CI 8 M16X1.5 GEOMET321 PLUS XL
48	07192600	RONDELLA SPECIALE HV 300 - D 17X48X6 GEOMET321/A+PLUS XL	SPECIAL WASHER HV 300 - 17X48X6 GEOMET321 D / A + PLUS XL	RONDELLE SPECIALE HV 300 - 17X48X6 GEOMET321 D / A + PLUS XL	SCHEIBE HV 300 - 17X48X6 GEOMET321 D / A + PLUS XL	ARANDELA ESPECIAL HV 300 - 17X48X6 GEOMET321 D / A + PLUS XL
49	07690700	PROTEZIONE TRASPARENTE	PROTECTION	PROTECTION	SCHUTZ	PROTECCIÓN
50	06272700	BOCCOLA	BUSH	DOUILLE	BUCHSE	CASQUILLO
51	17569900	PROTEZIONE TELECOMANDO	PROTECTION REMOTE CONTROL	PROTECTION	SCHUTZ	PROTECCIÓN
52	07687300	RUOTE INFERIORI PER CESTO	LOWER WHEEL	ROULEAU INFERIEUR	UNTERES RAD	RUEDA INFERIOR
53	07751100	RUOTE INFERIORI PER CESTO CON FRENO	LOWER WHEELS FOR BASKET WITH BRAKE	ROUES POUR PANIER	KORBRÄDER	RUEDAS
54	37609800	TELAIO SUPPORTO SKY-GUARD CESTO BIPOSTO	SKY-FRAME SUPPORT GUARD BASKET 2PERSON	CHÂSSIS	RAHMEN	CHASIS

 SUPPORTO CESTO BASKET SUPPORT PANIER CUPPORTHALTERUNG ARBEITSKORB SOPORTE CESTA 

POS	Codice	 Descrizione	 Description	 Designation	 Benennung	 Descripción
55	07796900	BLOCCHETTO PLASTICA PER FISSAGGIO SKYGUARD (1001188889)	BLOCK PLASTIC FOR SECURING SKYGUARD (1001188889)	BLOC	BLOCK	BLOQUE
56	07797000	COVER IN GOMMA PER PROTEZIONE FISSAGGIO SKY GUARD (1001186517)	COVER RUBBER PROTECTION FOR FIXING SKY GUARD (1001186517)	PROTECTION	SCHUTZ	PROTECCIÓN
57	27796800	SENSORE SKYGUARD	SENSOR SKYGUARD	CAPTEUR	SENSOR	SENSOR
58	17768100	KIT SKY GUARD COMPLETO BIPOSTO PER CCBS	SKYGUARD COMPLETE KIT FOR 2 PERSON CCBS	KIT SKY GUARD	SKY GUARD SATZ	KIT SKY GUARD
59	07766500	PERNO INCERNIERAMENTO MENSOLA SUPPORTO CESTO	PIN HINGE BRACKET SUPPORT BASKET	AXE	STIFT	PERNIO
60	07771500	MANIGLIA	HANDLE	POIGNÉE	GRIFF	MANIJA

Main color codes:  J1 - JLG Cream,  J2 - JLG Orange,  C4 - Green

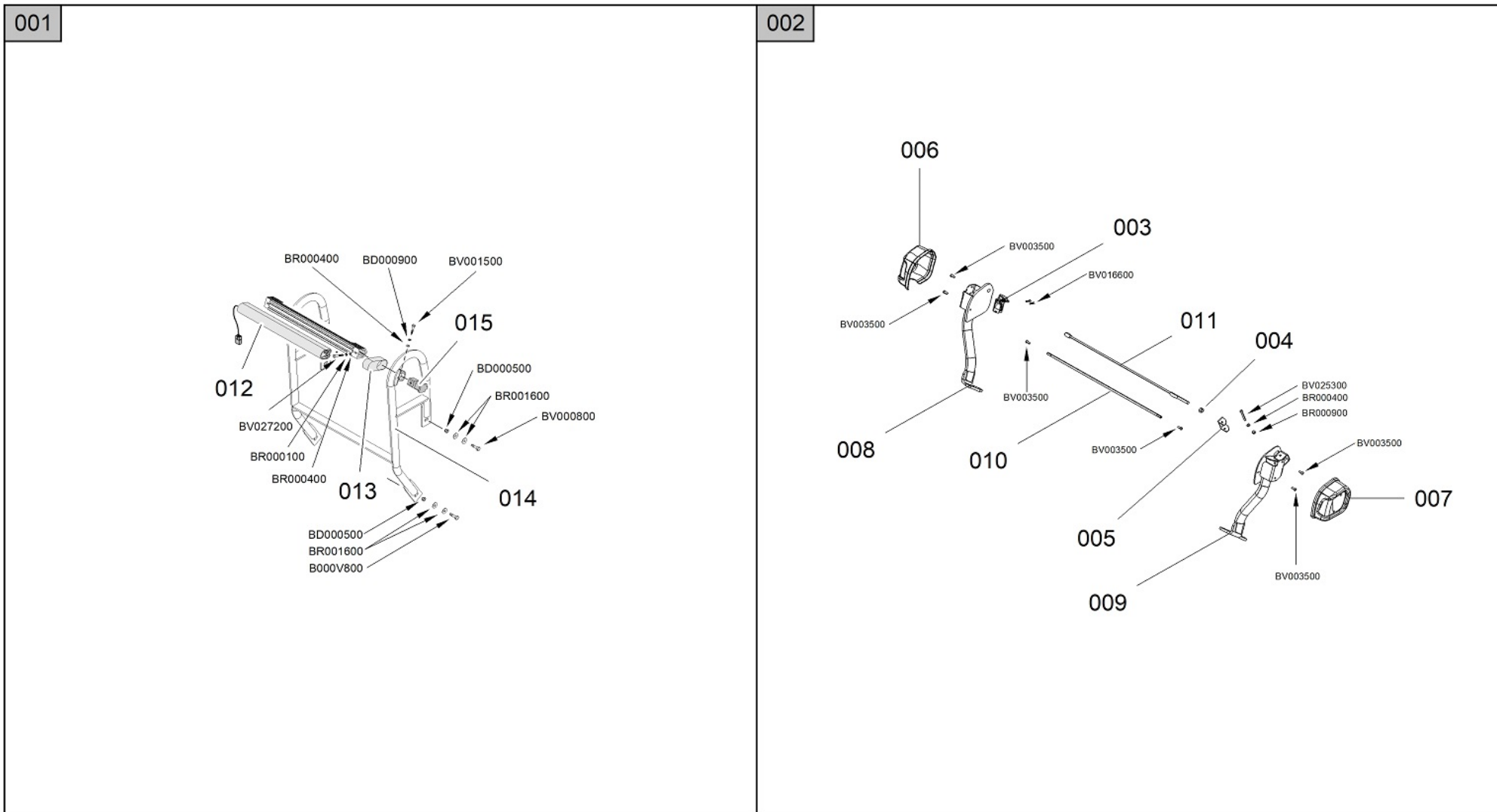



 SKY GUARD - SKY LINE

 SKY GUARD - SKY LINE

 SKY GUARD - SKY LINE
SKY GUARD - SKY LINE SKY GUARD - SKY LINE 



POS	Codice	 Descrizione	 Description	 Designation	 Benennung	 Descripción
2	18357200	KIT SKY LINE SU ATTACCO SKY GUARD MACCHINE JLG	CABLE ANTI- ENTRAPMENT SYSTEM	SYSTEME ANTI- ECRASEMENT AVEC CABLE	KABLE-ANTI- QUETSCH- VORRICHTUNG	SISTEMA ANTIAPLASTAMIENT O CON CABLE
2	18357300	KIT SKY LINE COMPLETO BIPOSTO HINOWA	SKYLINE COMPLETE KIT FOR 2 PERSON HINOWA	KIT SKY LINE	SKY LINE SATZ	KIT SKY LINE
3	18310600	MICRO	MICRO WITH WIRING	MICROINTERRPTEUR	MIKROSCHALTER	MICROINTERRUPTOR
4	3311601	DADO SPECIALE	NUT HEX, .375-16 REG HT	NUT HEX	NUT HEX	NUT HEX
5	383036Y1	SUPPORTO	SUPPORT	SUPPORT	HALTERUNG	SOPORTE
6	08310700	COVER DESTRA SKYLINE	SKYLINE RIGHT COVER	COUVERTURE DROITE	RECHTE ABDECKUNG	COBERTURA
7	08310800	COVER SINISTRA SKYLINE	SKYLINE LEFT COVER	COUVERTURE GAUCHE	LINKE ABDECKUNG	COBERTURA IZQUIERDA
8	38302200	SUPPORTO DESTRO	SUPPORT	SUPPORT	HALTERUNG	SOPORTE
9	38302300	SUPPORTO SINISTRO	SUPPORT	SUPPORT	HALTERUNG	SOPORTE
10	08309700	DISTANZIALE	SPACER	ÉPAISSEUR	DISTANZSTÜCK	ESPACIADOR
11	08132300	BACCHETTA IN FIBRA DI VETRO	GLASS FIBER WAND	BAGUETTE EN FIBRE DE VERRE	GLASFASERSTAB	VARILLA DE FIBRA DE VIDRIO

Main color codes:  J1 - JLG Cream,  J2 - JLG Orange,  C4 - Green



 ACCOPPIAMENTO MOTORE DIESEL- POMPA

 DIESEL ENGINE COUPLING - PUMP

 ACCOUPLEMENT MOTEUR DIESEL - POMPE

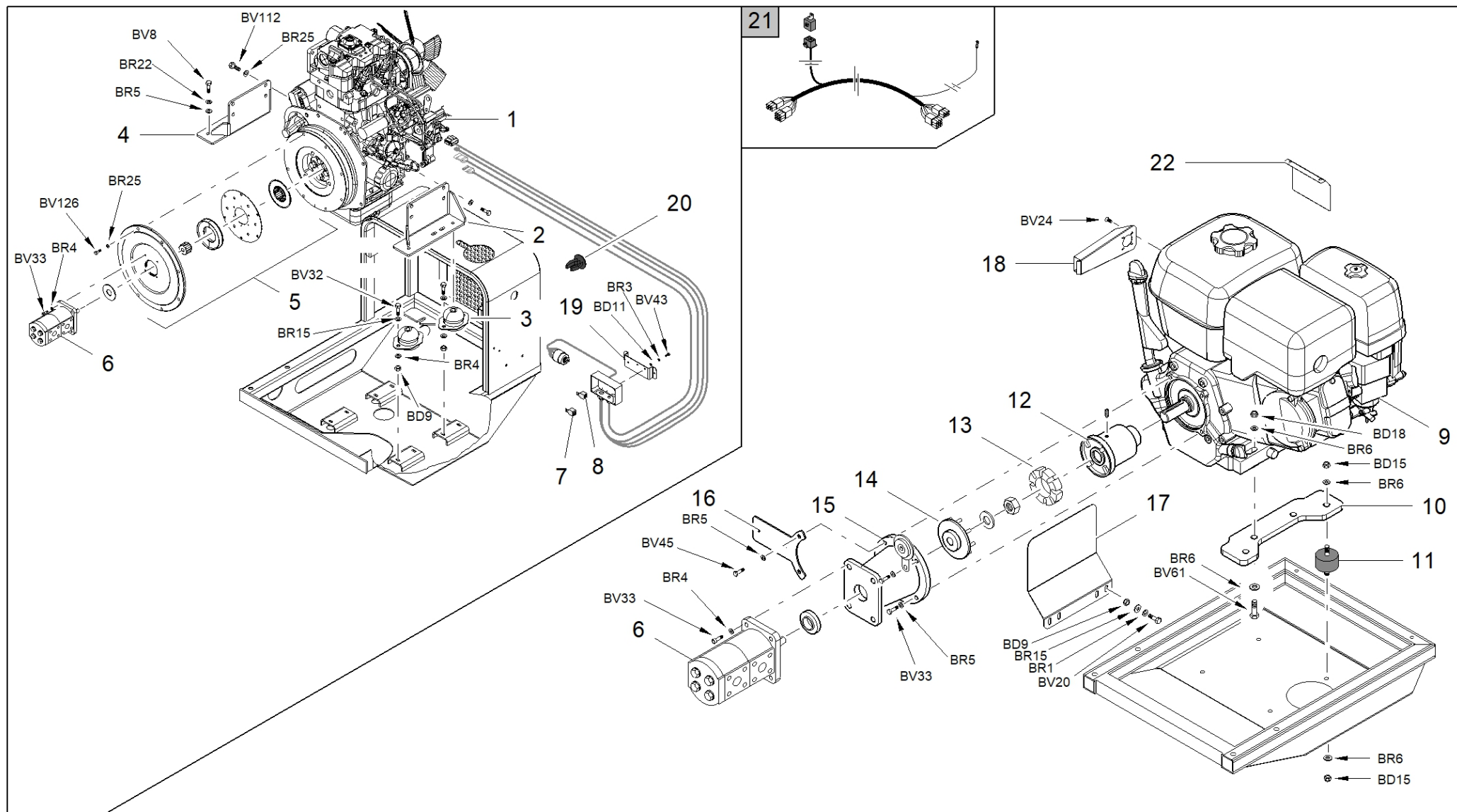
PUMPEN / DIESELMOTOR KUPPLUNG 
 ACOPLAMIENTO MOTOR DIESEL- BOMBA 









Main color codes:  J1 - JLG Cream,  J2 - JLG Orange,  C4 - Green



 ACCOPPIAMENTO MOTORE DIESEL- POMPA

 DIESEL ENGINE COUPLING - PUMP

 ACCOUPLEMENT MOTEUR DIESEL - POMPE

 PUMPEN / DIESELMOTOR KUPPLUNG 
 ACOPLAMIENTO MOTOR DIESEL- BOMBA 

POS	Codice	 Descrizione	 Description	 Designation	 Benennung	 Descripción
1	26458100	MOTORE DIESEL 14HP (NO CARB-EPA CERT)	DIESEL ENGINE 14HP (NO CARB-EPA CERT)	MOTEUR DIESEL	DIESELMOTOR	MOTOR DIESEL
1	2645810028	CINGHIA PER 102.05 - 103.07*	BELT FOR 102.05 - 103.07*	CEINTURE	RIEMEN	CORREA
2	063134Y1	SUPPORTO	SUPPORT	SUPPORT	HALTERUNG	SOPORTE
3	06458400	ANTIVIBRANTE	ANTI-VIBRATING	ANTI - VIBRANT	VIBRATIONSDÄMPFER	ANTIVIBRANTE
4	063135Y1	SUPPORTO	SUPPORT	SUPPORT	HALTERUNG	SOPORTE
5	26458500	ACCOPPIAMENTO MOTORE DIESEL - POMPA	DIESEL ENGINE COUPLING - PUMP	ACCOUPLEMENT MOTEUR DIESEL - POMPE	PUMPEN / DIESELMOTOR KUPPLUNG	ACOPLAMIENTO MOTOR DIESEL- BOMBA
6	146152H3	POMPA IDRAULICA	HYDRAULIC PUMP	POMPE HYDRAULIQUE	HYDRAULIKPUMPE	BOMBA HYDRÁULICA
7	1730720002	RELE' COMANDO MOTORE DIESEL	RELAY 'CONTROL DIESEL ENGINE	CONTROLE MOTEUR DIESEL RELAY '	RELAY 'CONTROL DIESEL MOTOR	RELE 'CONTROL DE MOTOR DIESEL
8	1730720003	FUSIBILE A LAMA 70A	FUSE BLADE 70A	FUSE BLADE 70A	FUSE BLADE 70A	HOJA FUSE 70A
9	25952600	MOTORE BENZINA	PETROL ENGINE	MOTEUR A ESSÉNCÉ	BENZINMOTOR	MOTOR DE GASOLINA
9	27676500	MOTORE HONDA IGX440 MODIFICATO SENZA BLOCCHETTO CHIAVE DI ACCENSIONE MK2 (FROM C170000893)	HONDA MOTOR IGX440 MODIFIED WITHOUT IGNITION SWITCH MK2 (FROM C170000893)	MOTEUR HONDA IGX440	HONDA MOTOR IGX440	MOTOR HONDA IGX440
10	046393H3	SUPPORTO MOTORE HONDA GX390	SUPPORT ENGINE HONDA GX390	SUPPORT HONDA GX390	HALTERUNG HONDA GX390	SOPORTE HONDA GX390
10	059551H2	PIATTO HONDA IGX440	PLATE HONDA IGX440	PLATEAU HONDA IGX440	PLATTE HONDA IGX440	PLACA HONDA IGX440
11	05535300	ANTIVIBRANTE VERSIONE BENZINA	ANTI-VIBRATING GASOLINE VERSION	ANTI - VIBRANT	VIBRATIONSDÄMPFER	ANTIVIBRANTE
12	04310200	SEMIGIUNTO	HALF COUPLING	DEMI-JOINT	HALBVERBINDUNG	SEMI-ACOPLAMIENTO
13	04310100	INSERTO IN GOMMA	RUBBER INSERT	INSERT EN CAOUTCHOUC	GUMMIEINSATZ	INSERTO DE GOMA
14	04615300	GIUNTO	COUPLING	JOINT	VERBINDUNG	ACOPLAMIENTO
15	04310300	LANTERNA	LANTERN	LANTERNE	LANTERNE	LINTERNA

 Main color codes:  J1 - JLG Cream,  J2 - JLG Orange,  C4 - Green





 ACCOPPIAMENTO MOTORE DIESEL- POMPA



 DIESEL ENGINE COUPLING - PUMP



 ACCOUPLEMENT MOTEUR DIESEL - POMPE

 PUMPEN / DIESELMOTOR KUPPLUNG



 ACOPLAMIENTO MOTOR DIESEL- BOMBA

POS	Codice	 Descrizione	 Description	 Designation	 Benennung	 Descripción
16	061177H2	STAFFA	BRACKET	ÉTRIER	HALTEBÜGEL	ESTRIBO
17	061907H2	PROTEZIONE	PROTECTION	PROTECTION	SCHUTZ	PROTECCIÓN
18	059220Y1	DEFLETTORE	DEFLECTOR	DÉFLECTEUR	ABWEISER	DEFLECTOR
19	073265Y1	PIEGATO FISSAGGIO COMPONENTI ELETTRICI	FIXING FOLDED ELECTRICAL COMPONENTS	FIXATION DES COMPOSANTS ÉLECTRIQUES PLIE	BEFESTIGUNG GEFALTETEN ELEKTROKOMPONEN TEN	FIJACIÓN DE COMPONENTES ELÉCTRICOS PLEGABLES
20	07690400	TAPPO IN PLASTICA PER FORO DA Ø=22- 30MM	PLASTIC CAP Ø=22- 30MM FOR CLOSING HOLES	COUVERCLE	ABDECKUNG	TAPA
21	17535700	KIT RELE' AGGIUNTIVO PER SPEGNIMENTO MOTORE HONDA IGX440	ADDITIONAL RELAY KIT FOR POWER-OFF HONDA MOTOR IGX440	RELAIS	RELAIS	RELÉ
21	17965000	KIT RELE' AGGIUNTIVO SEGNALE MOTORE ACCESO HONDA IGX390	KIT RELAY 'ADDITIONAL SIGNAL ON HONDA MOTOR IGX390	KIT RELAIS	RELAIS KIT	KIT RELÉ
22	07798300	PROTEZIONE CARBURATORE LL1775	CARBURETOR PROTECTION FOR LL1775	PROTECTION	SCHTUZ	PROTECCIÓN

 RICAMBI MOTORE DIESEL
 ENGINE SPARE PARTS DIESEL
 PIÈCES DÉTACHÉES DU MOTEUR DIESEL

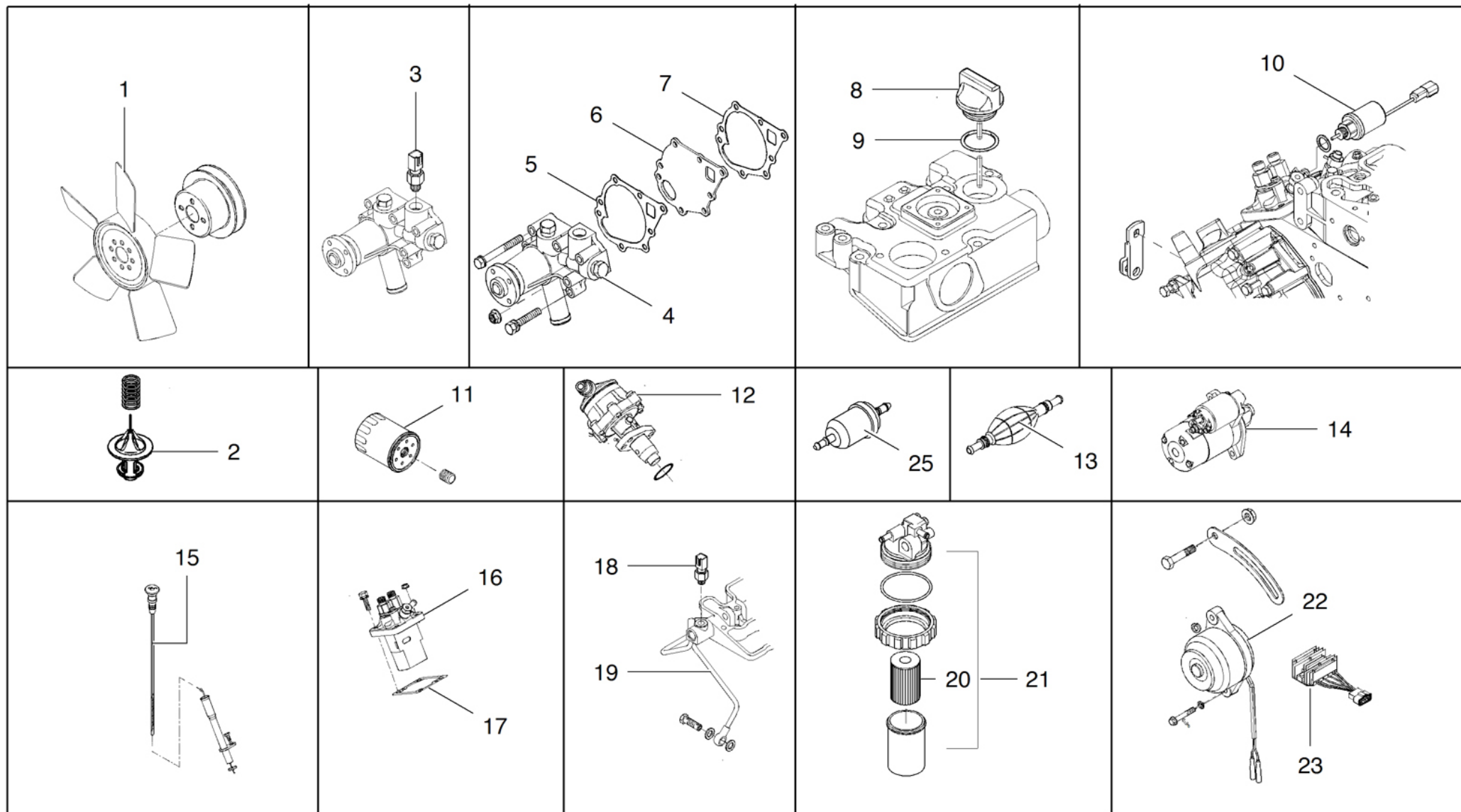
MOTORERSATZTEILE DIESEL 
 REPUESTOS MOTOR DIESEL 



Main color codes:  J1 - JLG Cream,  J2 - JLG Orange,  C4 - Green

 RICAMBI MOTORE DIESEL



 ENGINE SPARE PARTS DIESEL

 PIÈCES DÉTACHÉES DU MOTEUR DIESEL

 MOTORERSATZTEILE DIESEL

 REPUESTOS MOTOR DIESEL

POS	Codice	 Descrizione	 Description	 Designation	 Benennung	 Descripción
1	2645810008	VENTOLA	FAN	VENTILATEUR	LÜFTERRAD	VENTILADOR
2	2645810007	TERMOSTATO	THERMOSTAT	THERMOSTAT	TEMPERATURREGLER	TERMÓSTATO
3	2645810019	BULBO TEMPERATURA ACQUA	WATER TEMPERATURE BULB	BOULE TEMPÉRATURE EAU	WASSERTEMPERATU RKUGEL	CUBETA TEMPERATURA AGUA
4	2645810023	POMPA ACQUA	WATER PUMP	POMPE À EAU	WASSERPUMPE	BOMBA DE AGUA
5	2645810009	GUARNIZIONE	GASKET	JOINT	DICHTUNG	GUARNICIÓN
6	2645810006	PIASTRA	PLATE	PLATINE	PLATTE	PLACA
7	2645810010	GUARNIZIONE	GASKET	JOINT	DICHTUNG	GUARNICIÓN
8	2645810016	TAPPO OLIO	OIL PLUG	BOUCHON D'HUILE	ÖLDECKEL	OLIEDOP
9	2645810001	GUARNIZIONE	GASKET	JOINT	DICHTUNG	GUARNICIÓN
10	2645810020	SOLENOIDE	SOLENOID	SOLENOÏDE	SOLENOID	SOLENOIDE
11	04271000	FILTRO OLIO	OIL FILTER	FILTRE À HUILE	ÖLFILTER	FILTRO ACEITE
12	2645810021	POMPA ALIMENTAZIONE GASOLIO	GAS OIL FUEL PUMP	POMPE D'ALIMENTATION DIESEL	DIESEL FÖRDERPUMPE	BOMBA DEALIMENTACIÓN GASOLEO
13	07495500	POMPANTE ALIMENTAZIONE GASOLIO	GAS OIL FUEL PUMP	POMPE D'ALIMENTATION GASOIL	KRAFTSTOFFVRSOR GUNGSPUMPE	BOMBA DE ALIMENTACIÓN GASOLEO
14	2645810012	MOTORINO AVVIAMENTO	STARTER MOTOR	DÉMARREUR	ANLASSER	MOTOR DE ARRANQUE
15	2645810015	ASTINA LIVELLO OLIO	OIL DIPSTICK	TIPE NIVEAU HUILE	ÖLSTANDSTAB	VARILLA NIVEL ACEITE
16	2645810003	POMPA INIEZIONE	INJECTION PUMP	POMPE D'INJECTION	EINSPRITZPUMPE	EINSPRITZPUMPE
17	2645810004	GUARNIZIONE	GASKET	JOINT	DICHTUNG	GUARNICIÓN
18	2645810013	BULBO PRESSIONE OLIO	BULB	BOULE	OILTEMPERATUURBO L	CUBETA
19	2645810005	TUBO	PIPE	TUYAU	ROHR	TUBO
20	04089800	CARTUCCIA FILTRO OLIO	OIL FILTER CARTRIDGE	CARTOUCHE FILTRE À HUILE	ÖLFILTREINSATZ	FILTRO DE ACEITE
21	2645810002	FILTRO GASOLIO	GAS OIL FILTER	FILTRE À GASOIL	KRAFTSTOFFFILTER	FILTRO GASÓLEO
22	2645810011	ALTERNATORE	ALTERNATOR	ALTERNATEUR	WECHSELSTROMGEN ERATOR	ALTERNADOR

Main color codes:  J1 - JLG Cream,  J2 - JLG Orange,  C4 - Green





 RICAMBI MOTORE DIESEL

 ENGINE SPARE PARTS DIESEL

 PIÈCES DÉTACHÉES DU MOTEUR DIESEL

 MOTORERSATZTEILE DIESEL

 REPUESTOS MOTOR DIESEL

POS	Codice	 Descrizione	 Description	 Designation	 Benennung	 Descripción
23	2645810014	REGOLATORE DI TENSIONE	VOLTAGE REGULATOR	RÉGULATEUR DE TENSION	SPANNUNGSREGLER	REGULADOR DE TENSIÓN
25	05006700	FILTRO GASOLIO CON RETE FB13 PER MOTORE PERKINS	IN-LINE DIESEL FILTER VT3000-VT4000	FILTRE GASOIL	DIESELFILTER IN-LINIE VT3000-VT4000	FILTRO GASOLEO

 RICAMBI MOTORE DIESEL



 ENGINE SPARE PARTS DIESEL

 PIÈCES DÉTACHÉES DU MOTEUR DIESEL

 MOTORERSATZTEILE DIESEL

 REPUESTOS MOTOR DIESEL

POS	Codice	 Descrizione	 Description	 Designation	 Benennung	 Descripción
1	25659000	FILTRO ARIA	AIR FILTER	FILTER À AIR	LUFTFILTER	FILTRO AIRE
2	04091400	CARTUCCIA FILTRO ARIA	AIR FILTER CARTRIDGE	CARTOUCHE FILTRE À AIR	LUFTFILTEREINSATZ	CARTUCHO FILTRO DE AIRE
3	073266Y1	PIEGATO FISSAGGIO FILTRO ARIA	FIXING BENDED AIR FILTER	FIXATION PLIE FILTRE A AIR	BEFESTIGUNG GEFALTETEN AIR FILTER	FIJACIÓN DE FILTRO DE AIRE FOLDED
4	04125900	MANICOTTO	SLEEVE	MANCHON	MUFFE	MANGUITO
5	2645830001	TAPPO	CAP	BOUCHON	VERSCHLUSS	TAPÓN
6	064699Y1	STAFFA	BRACKET	ÉTRIER	HALTEBÜGEL	ESTRIBO
7	05689400	ANTIVIBRANTE Ø25 H=15 FILETTO M6X18	ANTIVIBRATION Ø25 H = 15 M6X18	ANTI - VIBRANT	VIBRATIONSDÄMPFER	ANTIVIBRANTE
8	27313000	RADIATORE	RADIATOR	RADIATEUR	KÜHLER	RADIATOR
9	06145700	ANTIVIBRANTE	ANTI-VIBRATING	ANTI - VIBRANT	VIBRATIONSDÄMPFER	ANTIVIBRANTE
10	07286500	MARMITTA	MUFFLER	SILENCIEUX	ABBLASDÄMPFER	SILENCIADOR
11	25779900	VASCHETTA ACQUA	WATER RESERVOIR	BASSINET EAU	WASSERBECKEN	PILA AQUA
12	372847Y1	SUPPORTO VASCHETTA ESPANSIONE RADIATORE	SUPPORT RADIATOR EXPANSION TANK	SUPPORT RADIATEUR EXPANSION TANK	SUPPORT KÜHLER EXPANSION TANK	SOPORTE RADIADOR TANQUE DE EXPANSIÓN
13	07326800	TUBO ASPIRAZIONE MOTORE DIESEL ARIA	DIESEL ENGINE AIR INTAKE PIPE	TUYAU D'ASPIRATION	SAUGSCHLAUCH	MANGUERA DE ASPIRACIÓN
14	27041300	INTERRUTTORE A CHIAVE PRERISCALDO ANTI-RIAVVIO	KEY SWITCH HEATING ANTI-RESTART	KEY CHAUFFAGE DE CONTACT ANTI-REDÉMARRAGE	KEY SWITCH HEIZUNG ANTI-NEUSTART	CLAVE DE CALEFACCIÓN INTERRUPTOR ANTI-ARRANQUE
15	2704130001	CHIAVE PER INTERRUTTORE PRERISCALDO ANTI-RIAVVIO DIESEL	KEY FOR SWITCH HEATING ANTI-RESTART	CLE CHAUFFAGE DIESEL ANTI-REDÉMARRAGE	KEY SWITCH HEIZUNG DIESEL ANTI-NEUSTART	LLAVE DE CALEFACCIÓN DIESEL ANTI-ARRANQUE
16	06518200	ADATTATORE	ADAPTER	ADAPTATEUR	ADAPTER	ADAPTADOR
17	26514900	SENSORE	SENSOR	CAPTEUR	SENSOR	SENSOR
18	06471500	PERNO	PIN	GOUJON	ZAPFEN	PERNIO

Main color codes:  J1 - JLG Cream,  J2 - JLG Orange,  C4 - Green





 RICAMBI MOTORE DIESEL



 ENGINE SPARE PARTS DIESEL



 PIÈCES DÉTACHÉES DU MOTEUR DIESEL

 MOTORERSATZTEILE DIESEL



 REPUESTOS MOTOR DIESEL

POS	Codice	 Descrizione	 Description	 Designation	 Benennung	 Descripción
19	06471400	TIRANTE	TIE ROD	TIRANT	TURMGESTÄNGE	TIRANTE
20	26551500	PISTONE	PISTON	PISTON	KOLBEN	PISTÓN
21	06551400	ANTIVIBRANTE	ANTI-VIBRATING	ANTI - VIBRANT	VIBRATIONSDÄMPFER	ANTIVIBRANTE
22	065513Y1	STAFFA	BRACKET	ÉTRIER	HALTEBÜGEL	ESTRIBO
23	05476400	MANICOTTO	SLEEVE	MANCHON	MUFFE	MANGUITO
24	073267Y1	PIEGATO FISSAGGIO FILTRO DIESEL	FIXING BENDED FILTER DIESEL	FIXATION PLIE FILTRE À GAZOLE	BEFESTIGUNG FALTENFILTERS DIESEL	FIJACIÓN DE DOBLADO FILTRO DIESEL

 RICAMBI MOTORE BENZINA
 ENGINE SPARE PARTS GASOLINE
 PIÈCES DÉTACHÉES DU MOTEUR PETROL

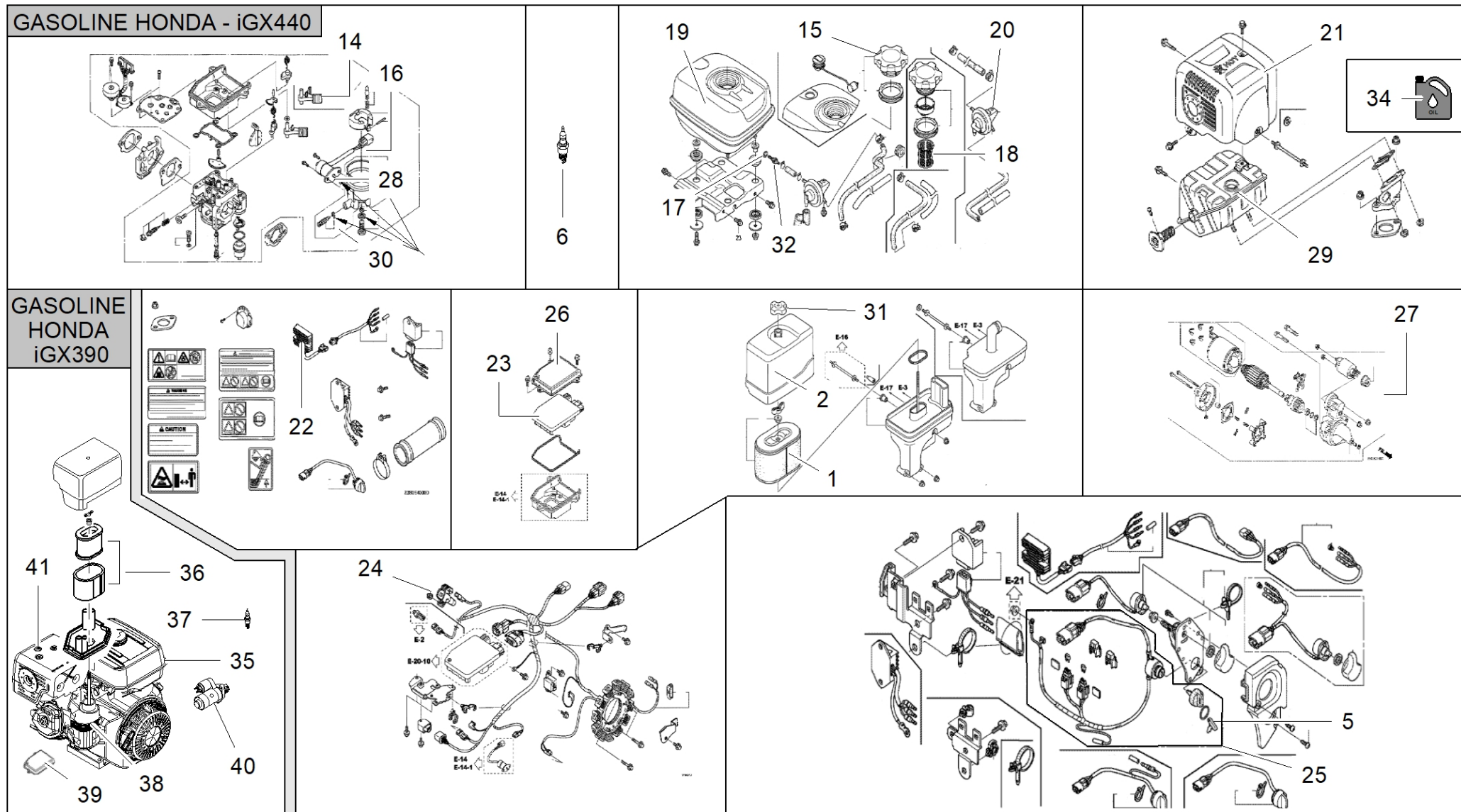
MOTORERSATZTEILE BENZIN 
 REPUESTOS MOTOR GASOLINA 











Main color codes:  J1 - JLG Cream,  J2 - JLG Orange,  C4 - Green

 RICAMBI MOTORE BENZINA

 ENGINE SPARE PARTS GASOLINE

 PIÈCES DÉTACHÉES DU MOTEUR PETROL
MOTORERSATZTEILE BENZIN REPUESTOS MOTOR GASOLINA 

POS	Codice	 Descrizione	 Description	 Designation	 Benennung	 Descripción
1	2595260001	FILTRO ARIA	AIR FILTER	FILTER À AIR	LUFTFILTER	FILTRO AIRE
2	2595260002	COPERCHIO	COVER	COUVERCLE	DECKEL	TAPA
5	2595260003	CHIAVE ACCENSIONE MOTORE	KEY IGNITION ENGINE	CLÉ MOTEUR D'ALLUMAGE	ZÜNDUNGSSCHALTER ENGINE	MOTOR LLAVE
6	2595260004	CANDELA ACCENSIONE	SPARKING PLUG	BOUGIE ÉLECTRIQUE	ZÜNDKERZE	BUJÍA ENCENDIDO
14	2558640008	SPIILLO	SPIILLO	AIGUILLE	NADEL	AGUJA
15	2558640012	TAPPO SERBATOIO BENZINA	FUEL TANK CAP	BOUCHON RESERVOIR CARBURANT	TANKDECKEL	TANQUE CAP
16	2595260005	CARBURATORE PER IGX440	CARBURETOR FOR IGX440	CARBURATEUR POUR IGX440	VERGASER FÜR IGX440	CARBURADOR PARA IGX440
17	2558640031	O-RING PER FILTRO BENZINA	O-RING FOR FUEL FILTER	O-RING POUR FILTRE A CARBURANT	O-RING FÜR KRAFTSTOFF FILTER	ANILLO DE FILTRO DE COMBUSTIBLE
18	2595260006	FILTRO BENZINA SERBATOIO	FILTER FUEL TANK	RESERVOIR DE CARBURANT FILTRE	FILTER FUEL TANK	TANQUE DE COMBUSTIBLE FILTRO
19	2595260008	SERBATOIO BENZINA IGX440IU	FUEL TANK IGX440IU	RESERVOIR DE CARBURANT IGX440IU	FUEL TANK IGX440IU	TANQUE DE COMBUSTIBLE IGX440IU
20	2595260007	ASSIEME RUBINETTO AUTOMATICO CARBURANTE	AUTOMATIC FUEL VALVE ASSEMBLY	ROBINET AUTOMATIQUE	AUTOMATISCHER WASSERHAHN	GRIFO AUTOMÁTICO
21	2595260009	PROTEZIONE MARMITTA HONDA IGX440	PROTECTION MUFFLER HONDA IGX440	PROTECTION D'ECHAPPEMENT	HITZESCHUTZGITTER	PROTECCIÓN DEL SILENCIADOR
22	2595260012	REGOLATORE MOTORI HONDA IGX440	REGULATOR HONDA MOTORS IGX440	REGULATEUR	REGULATOR	REGULADOR
23	2595260013	SCHEDA CARBURATORE GX440	BOARD CARBURETOR GX440	CARTE DE CARBURANT	VERGASER KARTE	TARJETA DE COMBUSTIBLE
24	2595260024	BOBINA ACCENSIONE MOTORE IGX440	IGNITION COIL MOTOR IGX440	BOBINE D'ALLUMAGE MOTEUR IGX440	ZÜNDSPULE MOTOR IGX440	BOBINA MOTOR IGX440

Main color codes:  J1 - JLG Cream,  J2 - JLG Orange,  C4 - Green





 RICAMBI MOTORE BENZINA

 ENGINE SPARE PARTS GASOLINE

 PIÈCES DÉTACHÉES DU MOTEUR PETROL

 MOTORERSATZTEILE BENZIN

 REPUESTOS MOTOR GASOLINA

POS	Codice	 Descrizione	 Description	 Designation	 Benennung	 Descripción
25	2595260015	ASSIEME INTERUTTORI MOTORE IGX440 DA MATRICOLA MOTORE N°1002823	MOTOR ASSEMBLY SWITCHES IGX440 FROM ENGINE SERIAL N ° 1002823	COMMUTATEURS MOTEUR IGX440	SCHALTER MOTOR IGX440	INTERRUPTORES MOTOR IGX440
26	2595260014	COPERCHIO CARBURATORE GX440	COVER CARBURETOR GX440	COVER CARBURATEUR GX440	COVER VERGASER GX440	CUBIERTA CARBURADOR GX440
27	2595260025	MOTORINO AVVIAMENTO MOTORE HONDA IGX440	STARTER MOTOR HONDA IGX440	STARTER MOTOR HONDA IGX440	STARTER MOTOR HONDA IGX440	MOTOR HONDA IGX440
28	2595260027	VASCHETTA CARBURATORE	TANK CARBURATOR	TANQUE DE COMBUSTÍVEL	FUEL TANK	TANQUE DE COMBUSTIBLE
29	2595260028	MARMITTA PER HONDA 440	SILENCER FOR HONDA 440	SILENCIEUX POUR HONDA 440	MUFFLER FÜR HONDA 440	SILENCIADOR PARA HONDA 440
30	2595260026	KIT GUARNIZIONI CARBURATORE	CARBURATOR GASKET KIT	CARBURETOR TROUSSE DE JOINT	VERGASERDICHTSAT Z KIT	CARBURADOR KIT DE JUNTAS
31	2595260029	DADO PER COPERCHIO FILTRO ARIA	NUT FOR AIR FILTER COVER	NUT POUR FILTRE A AIR COVER	NUT FOR LUFTFILTERDECKEL	TUERCA DE FILTRO DE AIRE CUBIERTA
32	2598600002	RACCORDO PER SERBATOIO	FITTING FOR TANK	MONTAGE DE RÉSERVOIR	PASSEND FÜR TANK	MONTAJE DE TANQUE
35	2775200002	SERBATOIO BENZINA COMPLETO HONDA IGX390	FUEL TANK COMPLETE HONDA IGX390	RÉSERVOIR ESSENCE	BENZINTANK	DEPÓSITO DE GASOLINA
36	2775200001	CARTUCCIA FILTRO ARIA COMPLETA HONDA IGX390	AIR FILTER CARTRIDGE COMPLETE HONDA IGX390	FILTRE À AIR	LUFTFILTER	FILTRO DE AIRE
37	2558640003	CANDELA ACCENSIONE	SPARKING PLUG	BOUGIE ÉLECTRIQUE	ZÜNDKERZE	BUJÍA ENCENDIDO





 RICAMBI MOTORE BENZINA

 ENGINE SPARE PARTS GASOLINE

 PIÈCES DÉTACHÉES DU MOTEUR PETROL

 MOTORERSATZTEILE BENZIN

 REPUESTOS MOTOR GASOLINA

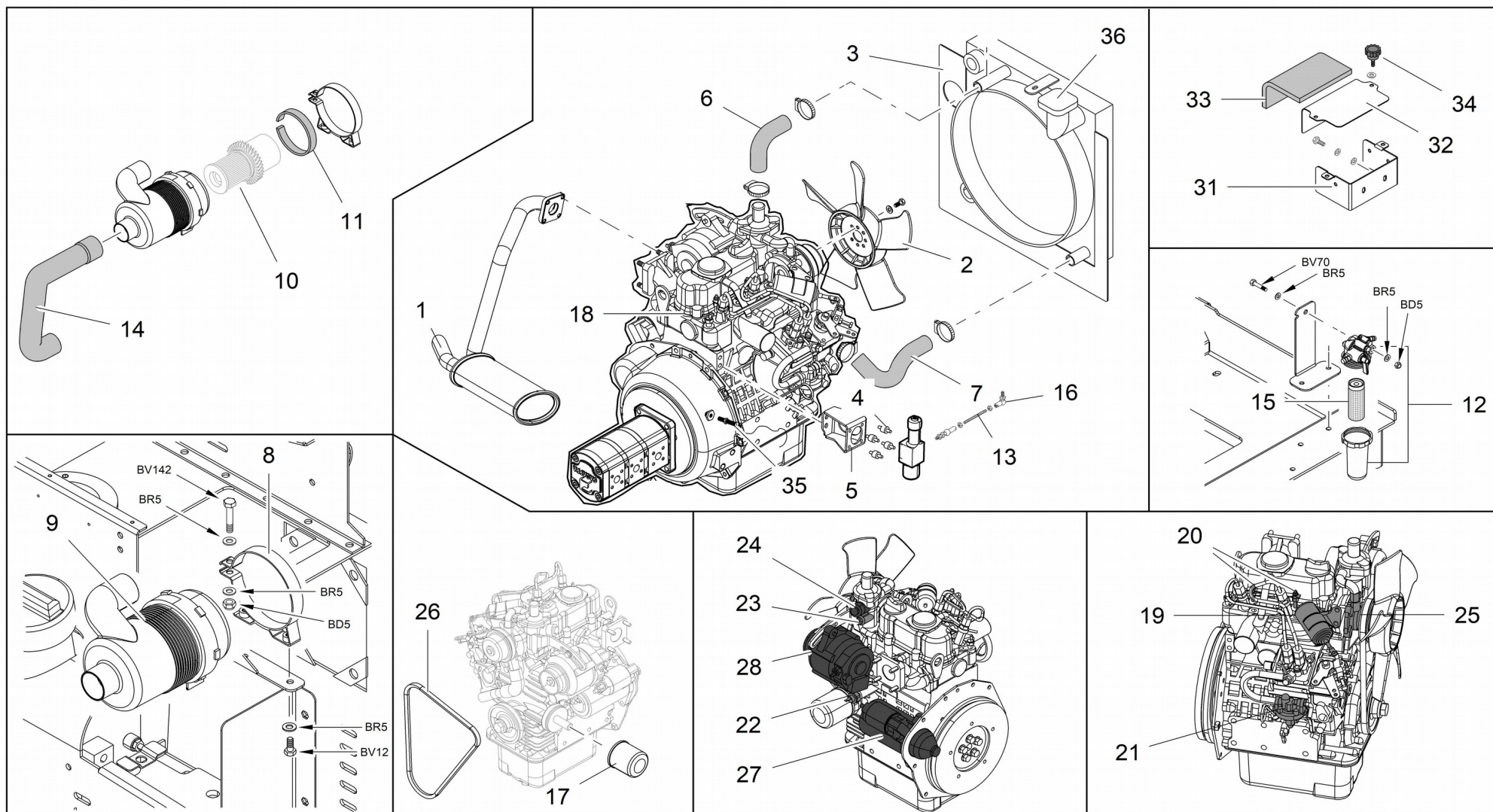

POS	Codice	 Descrizione	 Description	 Designation	 Benennung	 Descripció
38	2775200003	CARBURATORE COMPLETO HONDA IGX390 EURO 2(VALIDO FINO A SN MOTORE 3000001)	CARBURETOR COMPLETE HONDA IGX390 EURO 2 (VALID UNTIL ENGINE SN 3000001)	CARBURATEUR COMPLET HONDA IGX390 EURO 2 (VALABLE JUSQU'AU MOTEUR SN 3000001)	VERGASER KOMPLETT HONDA IGX390 EURO 2 (GÜLTIG BIS MOTOR SN 3000001)	CARBURADOR COMPLETO HONDA IGX390 EURO 2 (VÁLIDO HASTA MOTOR SN 3000001)
38	2775200006	CARBURATORE COMPLETO HONDA IGX390 STAGE V (VALIDO DA SN MOTORE 3000001)	CARBURETOR COMPLETE HONDA IGX390 STAGE V (VALID FROM ENGINE SN 3000001)	CARBURATEUR COMPLET HONDA IGX390 STAGE V (VALABLE A PARTIR DU NUMERO DE SERIE 3000001)	VERGASER KMPL. HONDA IGX390 STAGEV (GÜLTIG AB SERIENNR. 3000001)	CARBURADOR COMPLETO HONDA IGX390 STAGE V (VÁLIDO A PARTIR DEL NÚMERO DE SERIE 3000001)
39	2775200004	CENTRALINA ELETTRONICA HONDA IGX390	ELECTRONIC CONTROL UNIT HONDA IGX390	UNITÉ ÉLECTRONIQUE	ELEKTRONISCHE EINHEIT	UNIDAD ELECTRÓNICA
40	2775200005	MOTORINO DI AVVIAMENTO COMPLETO HONDA IGX390	ELECTRIC STARTER COMPLETE HONDA IGX390	MOTEUR DE DÉMARRAGE	MOTORSTART	MOTOR DE ARRANQUE
41	27775900	MOTORE HONDA IGX390 MODIFICATO SENZA BLOCCHETTO CHIAVE DI ACCENSIONE MK2 (DA C170000893)	HONDA MOTOR IGX390 MODIFIED WITHOUT IGNITION SWITCH MK2 (FROM C170000893)	MOTEUR HONDA IGX390	HONDA MOTOR IGX390	MOTOR HONDA IGX390



 RICAMBI MOTORE DIESEL KUBOTA





 ENGINE SPARE PARTS DIESEL KUBOTA





POS	Codice	 Descrizione	 Description	 Designation	 Benennung	 Descripción
1	08051800	MARMITTA	MUFFLER	SILENCIEUX	ABBLASDÄMPFER	SILENCIADOR
2	2805670005	VENTOLA SOFFIANTE	FAN BLOWER	VENTILATEUR	GEBLÄSE	VENTILADOR
3	28052700	RADIATORE	RADIATOR	RADIATEUR	KÜHLER	RADIATOR
4	08060600	ANTIVIBRANTE VERSIONE BENZINA	ANTI-VIBRATING GASOLINE VERSION	ANTI - VIBRANT	VIBRATIONSDÄMPFER	ANTIVIBRANTE
5	080523Y1	STAFFA FISSAGGIO ATTUATORE	ACTUATOR FIXING BRACKET	SUPPORT DE FIXATION ACTUATEUR	BEFESTIGUNGSHALTER ZU AKTUATOR	SOPORTE DE FIJACIÓN DEL ACTUADOR
6	08051900	MANICOTTO	SLEEVE	MANCHON	MUFFE	MANGUITO
7	08052000	MANICOTTO	SLEEVE	MANCHON	MUFFE	MANGUITO
8	07343100	STAFFA PER FILTRO ARIA	BRACKET FOR AIR FILTER	BRIDE FILTRE À AIR	KLAUE LUFTFILTER	ESTRIBO FILTRO DE AIRE
9	27345100	FILTRO ARIA PER MOTORE KUBOTA Z602	AIR FILTER FOR KUBOTA ENGINE Z602	FILTRE À AIR POUR MOTEUR KUBOTA Z602	LUFTFILTER FÜR KUBOTA MOTOR Z602	FILTRO DE AIRE MOTOR KUBOTA Z602
10	2734510001	CARTUCCIA ESTERNA FILTRO ARIA PER MOTORE KUBOTA Z602	EXTERNAL CARTRIDGE AIR FILTER FOR KUBOTA ENGINE Z602	CARTOUCHE EXTÉRIEURE FILTRE À AIR POUR MOTEUR KUBOTA Z602	AUßENPATRONE LUFTFILTER FÜR KUBOTAMOTOR Z602	CARTUCHO EXTERIOR FILTRO DE AIRE PARA MOTOR KUBOTA Z602
10	2734510002	CARTUCCIA INTERNA FILTRO ARIA PER MOTORE KUBOTA Z602	INTERNAL CARTRIDGE AIR FILTER FOR KUBOTA ENGINE Z602	CARTOUCHE INTÉRIEURE FILTRE À AIR POUR MOTEUR KUBOTA Z602	INNENPATRONE LUFTFILTER FÜR KUBOTAMOTOR Z602	CARTUCHO INTERNO FILTRO DE AIRE PARA MOTOR KUBOTA Z602
11	07430200	GUARNIZIONE PER STAFFA FILTRO ARIA 07342100	SEAL FOR BRACKET AIR FILTER 07342100	JOINT POUR BRIDE FILTRE À AIR 07342100	DICHTUNG FÜR LUFTFILTER-KLEMME 07342100	JUNTA PARA BRIDA FILTRO DE AIRE 07342100
12	17404200	FILTRO GASOLIO PER MOTORE KUBOTA Z602 D902	DIESEL FILTER FOR KUBOTA ENGINE Z602 D902	FILTRE À GASOIL POUR MOTEUR KUBOTA Z602 D902	DIESELFILTER FÜR KUBOTA MOTOR Z602 D902	FILTRO GASOIL PARA MOTOR KUBOTA Z602 D902
13	07598600	TIRANTE FILETTATO M6	TIE ROD	TIRANT	ZUGSTANGE	TIRANTE
14	07578000	MANICOTTO	SLEEVE	MANCHON	MUFFE	MANGUITO

Main color codes:  J1 - JLG Cream,  J2 - JLG Orange,  C4 - Green

 RICAMBI MOTORE DIESEL KUBOTA





 ENGINE SPARE PARTS DIESEL KUBOTA





POS	Codice	 Descrizione	 Description	 Designation	 Benennung	 Descripción
15	1740420001	CARTUCCIA FILTRO GASOLIO PER MOTORE Z602 D902	DIESEL FILTER CARTRIDGE FOR Z602 ENGINE D902	CARTOUCHE FILTRE À GASOIL POUR MOTEUR Z602 D902	DIESELFILTERELEME NT FÜR Z602 MOTOR D902	CARTUCHO FILTRO GASOIL PARA MOTOR Z602 D902
16	07598700	SNODO	ANGLE JOINTS	ARTICULATION	GELENK	ARTICULACIÓN
17	2734250002	CARTUCCIA FILTRO OLIO PER MOTORE Z602 D902	CARTRIDGE OIL FILTER FOR DIESEL Z602 D902	CARTOUCHE FILTRE À HUILE POUR MOTEUR Z602 D902	ÖLFILTERPATRONE FÜR MOTOR Z602 D902	CARTUCHO FILTRO ACEITE PARA MOTOR Z602 D902
18	2734250003	GUARNIZIONE COPERCHIO PUNTERIE PER MOTORE Z602 HS1102	TAPPETS ENGINE COVER SEAL FOR Z602 HS1102	KIT JOINT COUVERCLE POUSSOIRS POUR MOTEUR Z602 HS1102	DICHTUNG STÖSSELABDECKUNG FÜR MOTOR Z602 HS1102	JUNTA TAPA VÁLVULAS PARA MOTOR Z602 HS1102
19	2734250004	SOLENOIDE STOP PER MOTORE Z602 D902	STOP SOLENOID FOR MOTOR Z602 D902	ARRÊT SOLENOÏDE POUR MOTEUR Z602 D902	MAGNETSCHALTER FÜR MOTOR Z602 D902	SOLENOIDE STOP PARA MOTOR Z602 D902
20	2805670002	CANDELETTE PER MOTORE Z602 STAGE V	GLOW PLUGS ENGINE Z602 STAGE V	PETITES BOUGIES POUR MOTEUR Z602 STAGE V	KERZEN FÜR MOTOR Z602 STAGE V	BOUJÍAS PARA MOTOR Z602 STAGE V
21	2734250006	POMPA GASOLIO PER MOTORE Z602 HS1102	FUEL PUMP FOR MOTOR Z602 HS1102	POMPE GASOIL POUR MOTEUR Z602 HS1102	KRAFTSTOFFPUMPE Z602 HS1102	BOMBA GASOIL PARA MOTOR Z602 HS1102
22	2734250007	BULBO OLIO PER MOTORE Z602 D902	SENSOR ENGINE OIL Z602 D902	BOULE HUILE POUR MOTEUR Z602 D902	ÖLSENSOR FÜR MOTOR Z602 D902	BOLA ACEITE PARA MOTOR Z602 D902
23	2734250008	TERMOSTATO PER MOTORE Z602 D902	TEMPERATURE SENSOR FOR MOTOR Z602 D902	THERMOSTAT POUR MOTEUR Z602 D902	THERMOSTAT FÜR MOTOR Z602 D902	TERMÓSTATO PARA MOTOR Z602 D902
24	2734250009	BULBO ACQUA PER MOTORE Z602 D902	WATER SENSOR FOR MOTOR Z602 D902	BOULE EAU POUR MOTEUR Z602 D902	WASSER-SENSOR FÜR MOTOR Z602 D902	BOLA AGUA PARA MOTOR Z602 D902
25	2805670003	POMPA ACQUA PER MOTORE Z602 STAGE V	WATER PUMP FOR MOTOR Z602 STAGE V	POMPE À EAU POUR MOTEUR Z602 STAGE V	WASSERPUMPE FÜR MOTOR Z602 STAGE V	BOMBA DE AGUA PARA MOTOR Z602 STAGE V
26	2734250011	CINGHIA PER MOTORE Z602 D722 D902	BELT FOR MOTOR Z602 D722 D902	COURROIE POUR MOTEUR Z602 D722 D902	MOTORRIEMEN Z602 D722 D902	CORREA PARA MOTOR Z602 D722 D902



Main color codes:  J1 - JLG Cream,  J2 - JLG Orange,  C4 - Green

 RICAMBI MOTORE DIESEL KUBOTA



 ENGINE SPARE PARTS DIESEL KUBOTA

POS	Codice	 Descrizione	 Description	 Designation	 Benennung	 Descripción
27	2805670004	MOTORINO AVVIAMENTO PER MOTORE Z602 STAGE V	STARTER MOTOR Z602 STAGE V	MOTEUR DE DÉMARRAGE POUR MOTEUR Z602 STAGE V	ANLASSER Z602 STAGE V	MOTOR DE ARRANQUE PARA MOTOR Z602 STAGE V
28	2734250013	ALTERNATORE PER MOTORE Z602 D902	ALTERNATOR FOR MOTOR Z602 D902	ALTERNATEUR POUR MOTEUR Z602 D902	ALTERNATOR FÜR MOTOR Z602 D902	ALTERNADOR PARA MOTOR Z602 D902
29	07495500	POMPANTE ALIMENTAZIONE GASOLIO	GAS OIL FUEL PUMP	POMPE D'ALIMENTATION GASOIL	KRAFTSTOFFVERSOR GUNGSPUMPE	BOMBA DE ALIMENTACIÓN GASOLEO
30	05689500	ANTIVIBRANTE Ø20 H=8 FILETTO M6X18	ANTI-VIBRATION MOUNTS Ø20 M6X18	SUPPORT ELASTIQUE Ø20 M6X18	VIBRATIONSDÄMPFE R Ø20 M6X18	ANTIVIBRANTE Ø20 M6X18
31	075991Y1	PIEGATO FISSAGGIO COMPONENTI ELETTRICI	SUPPORT	SUPPORT	HALTERUNG	SOPORTE
31	1776330003	RELE' MINI TYCO 12V PER CONNETTORE A TENUTA (MK2 DA C170000893)	RELAY 'MINI 12V TYCO CONNECTOR SEAL (MK2 FROM C170000893)	RELAIS	RELAIS	RELÉ
31	2734250014	TIMER CANDELETTE PER MOTORE Z602 D902	TIMER FOR GLOW ENGINE Z602 D902	TEMPORISATEUR PETITES BOUGIES POUR MOTEUR Z602 D902	TIMER ZÜNDKERZEN FÜR MOTOR Z602 D902	TEMPORIZADOR BUJÍAS PARA MOTOR Z602 D902
31	2734250015	TIMER SPEGNIMENTO PER MOTORE Z602 D902	TIMER ENGINE STOP Z602 D902	TEMPORISATEUR POUR MOTEUR Z602 D902	TIMER FÜR MOTOR Z602 D902	TEMPORIZADOR PARA MOTOR Z602 D902
32	075992Y1	COPERCHIO	COVER	COUVERCLE	DECKEL	TAPA
33	07647100	RIVESTIMENTO	PROTECTION	PROTECTION	SCHUTZ	PROTECCION
34	05903300	POMELLO	KNOB	POIGNÉE	KUGELGRIFF	POMO
35	27602400	SENSORE DI GIRI PICK UP L=20,62MM	RPM SENSOR	CAPTEUR	DREHZAHLSENSOR	SENSOR
36	2805270001	TAPPO PER RADIATORE ACQUA	WATER RADIATOR CAP	BOUCHON POUR RADIATEUR D'EAU MOTEUR KUBOTA	KAPPE FÜR WASSERKÜHLER MOTOR KUBOTA	TAPA PARA RADIADOR DE AGUA MOTOR KUBOTA

 MOTORE ELETTRICO
 ELECTRIC MOTOR
 MOTEUR ÉLECTRIQUE

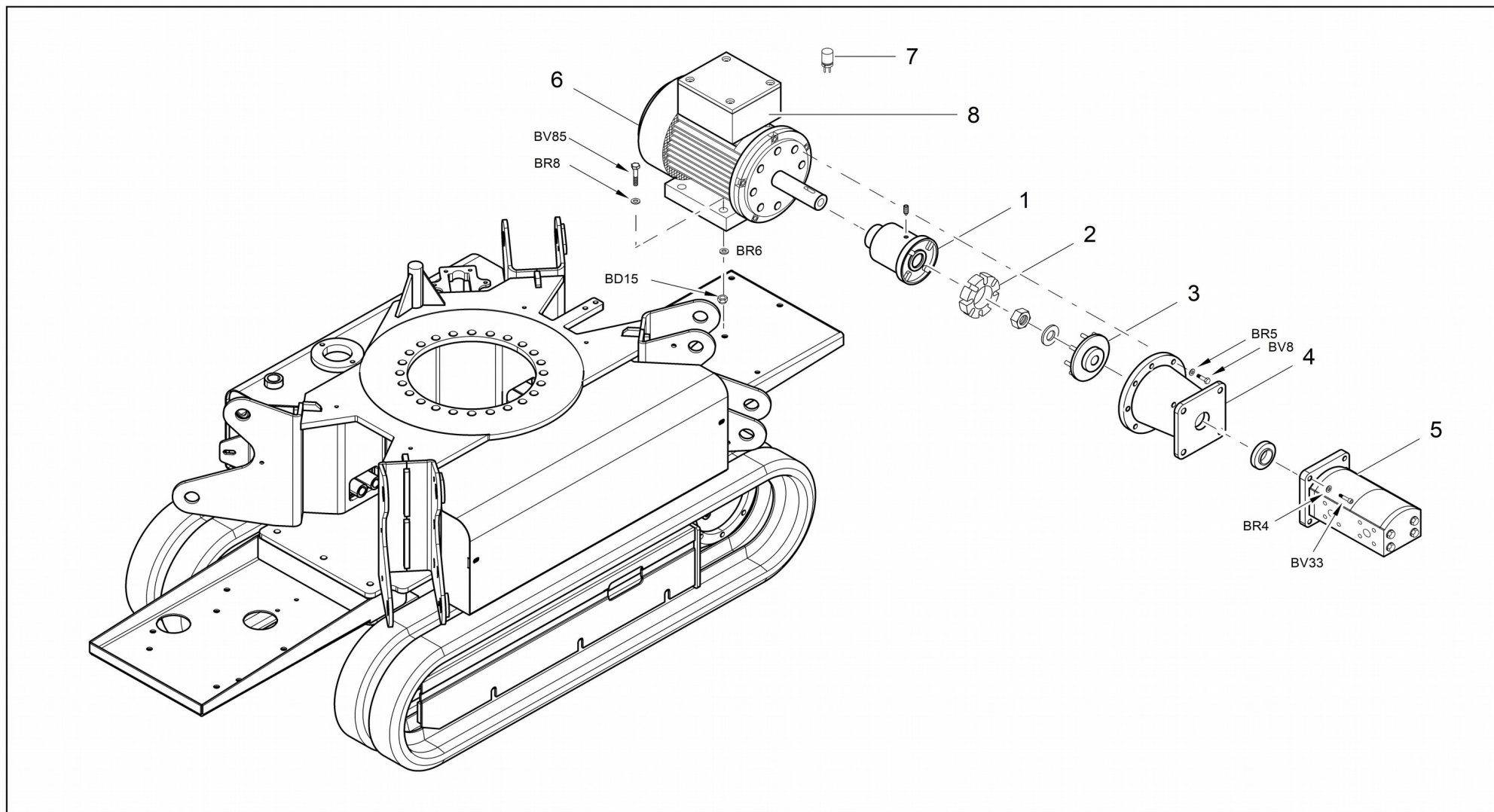
E-MOTOR 
MOTOR ELÉCTRICO 









Main color codes:  J1 - JLG Cream,  J2 - JLG Orange,  C4 - Green



 MOTORE ELETTRICO

 ELECTRIC MOTOR





 MOTEUR ÉLECTRIQUE

 E-MOTOR
 MOTOR ELÉCTRICO

POS	Codice	 Descrizione	 Description	 Designation	 Benennung	 Descripción
1	05563400	SEMIGIUNTO VERSIONE MOTORE ELETTRICO STANDARD	HALF COUPLING ELECTRIC MOTOR STANDARD VERSION	DEMI-JOINT	HALBKUPPLUNG	SEMI-ACOPLAMIENTO
1	06997800	SEMIGIUNTO VERSIONE LITIO	HALF COUPLING LITHIUM VERSION	DEMI-JOINT	HALBKUPPLUNG	SEMI-ACOPLAMIENTO
2	04310100	INSERTO IN GOMMA	RUBBER INSERT	INSERT EN CAOUTCHOUC	GUMMIEINSATZ	INSERTO DE GOMA
3	04615300	GIUNTO	COUPLING	JOINT	VERBINDUNG	ACOPLAMIENTO
4	05510200	LANTERNA	LANTERN	LANTERNE	LATERNE	LINTERNA
5	146152H3	POMPA IDRAULICA	HYDRAULIC PUMP	POMPE HYDRAULIQUE	HYDRAULIKPUMPE	BOMBA HYDRÁULICA
5	284674H3	POMPA IDRAULICA	HYDRAULIC PUMP	POMPE HYDRAULIQUE	HYDRAULIKPUMPE	BOMBA HYDRÁULICA
6	25510100	MOTORE ELETTRICO 230V 50HZ	ELECTRIC MOTOR 230V 50HZ	MOTEUR ÉLECTRIQUE 230V 50HZ	E-MOTOR 230V 50HZ	MOTOR ELÉCTRICO 230V 50HZ
6	25576400	MOTORE ELETTRICO 110V	ELECTRIC MOTOR 110V	MOTEUR ÉLECTRIQUE 110V	E-MOTOR 110V	MOTOR ELÉCTRICO 110V
6	26328300	MOTORE ELETTRICO 120V 60HZ 1.2KW 16A	ELECTRIC MOTOR 120V 60HZ 1.2KW 16A	MOTEUR ÉLECTRIQUE	E-MOTOR	MOTOR ELÉCTRICO
6	26948000	MOTORE ELETTRICO 3500W LITHIUM 72V	ELECTRIC MOTOR 3500W LITHIUM 72V	MOTEUR ÉLECTRIQUE 3500W LITHIUM 72V	E-MOTOR 3500W LITHIUM 72V	MOTOR ELÉCTRICO 3500W LITHIUM 72V
6	27691100	MOTORE ELETTRICO 230V 50HZ MK2 (DA C170000893)	ELECTRIC MOTOR 230V 50HZ MK2 (FROM C170000893)	MOTEUR ÉLECTRIQUE 230V 50HZ MK2 (FROM C170000893)	E-MOTOR 230V 50HZ MK2 (FROM C170000893)	MOTOR ELÉCTRICO 230V 50HZ MK2 (FROM C170000893)
7	2557640001	CONDENSATORE 110V MF200 D=65	CAPACITOR 110V MF200 D=65	CONDENSATEUR	CAPACITOR	CAPACITOR
7	2557640002	CONDENSATORE 110V MF500	CAPACITOR 110V MF500	CONDENSATEUR	CAPACITOR	CAPACITOR



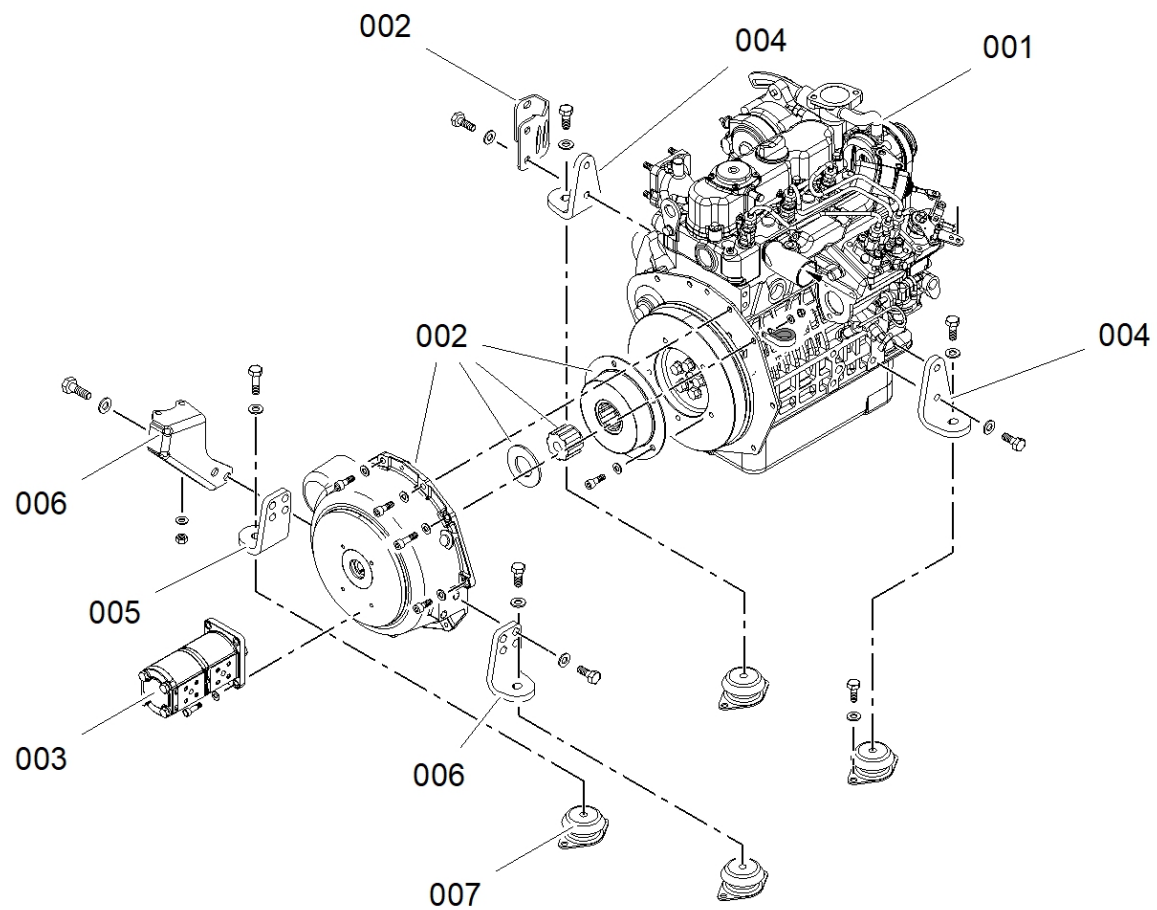

Main color codes:  J1 - JLG Cream,  J2 - JLG Orange,  C4 - Green

 MOTORE ELETTRICO ELECTRIC MOTOR MOTEUR ÉLECTRIQUEE-MOTOR MOTOR ELÉCTRICO 

POS	Codice	 Descrizione	 Description	 Designation	 Benennung	 Descripción
7	2632830001	CONDENSATORE PER MOTORE 120V MF120 D=55	CAPACITOR MOTOR 120V MF120 D = 55	CONDENSATEUR	KONDENSATOR	CONDENSADOR
7	2632830002	CONDENSATORE PER MOTORE 120V MF160 D=60	CAPACITOR MOTOR 120V MF160 D = 60	CONDENSATEUR	KONDENSATOR	CONDENSADOR
7	2769110001	CONDENSATORE 230V MF80 D=60 CL.B	CAPACITOR 230V MF80 D=60 CL.B	CONDENSATEUR D=60 CL.B	KONDENSATOR D=60 CL.B	CONDENSADOR D=60 CL.B
8	2769110002	SCATOLA CONDENSATORE CON GUARNIZIONE	CONDENSER BOX WITH GASKET	BOÎTE DE CONDENSEUR	KONDENSATORKAST EN	CAJA CONDENSADOR







POS	Codice	 Descrizione	 Description	 Designation	 Benennung	 Descripción
1	28056700	KIT MOTORE KUBOTA CON ACCESSORI PER LL2010-X20JP-X600AJ	KIT KUBOTA ENGINE WITH ATTACHMENTS FOR LL2010-X20JP-X600AJ	KIT MOTEUR KUBOTA AVEC ACCESSOIRES POUR LL2010-X20JP-X600AJ	KUBOTA MOTOR MIT ZUBEHÖRE LL2010-X20JP-X600AJ	KIT MOTOR KUBOTA CON ACCESORIOS PARA LL2010-X20JP-X600AJ
2	28053100	ACCOPPIAMENTO MOTORE DIESEL - POMPA	DIESEL ENGINE COUPLING - PUMP	ACCOUPLMENT MOTEUR DIESEL - POMPE	PUMPEN / DIESELMOTOR KUPPLUNG	ACOPLAMIENTO MOTOR DIESEL-BOMBA
3	263281H3	POMPA IDRAULICA	HYDRAULIC PUMP	POMPE HYDRAULIQUE	HYDRAULIKPUMPE	BOMBA HYDRÁULICA
4	075718Y1	SUPPORTO MOTORE KUBOTA POSTERIORE	SUPPORT	SUPPORT	HALTERUNG	SOPORTE
5	075716Y1	SUPPORTO MOTORE KUBOTA SINISTRO	LEFT KUBOTA ENGINE SUPPORT	SUPPORT MOTEUR KUBOTA GAUCHE	HALTERUNG KUBOTA MOTOR	SOPORTE MOTOR KUBOTA IZQUIERDO
6	075717Y1	SUPPORTO MOTORE KUBOTA DESTRO	RIGHT KUBOTA ENGINE SUPPORT	SUPPORT MOTEUR KUBOTA DROITE	KUBOTA MOTOR HALTERUNG	SOPORTE MOTOR KUBOTA DERECHO
7	27018000	ANTIVIBRANTE	ANTI-VIBRATING	ANTI - VIBRANT	VIBRATIONSDÄMPFER	ANTIVIBRANTE



 IMPIANTO IDRAULICO MANDATE E SCARICO

 SUPPLY AND DISCHARGE HYDRAULIC SYSTEM

 SYSTÈME HYDRAULIQUE REFOULEMENT ET DÉCHARGEME

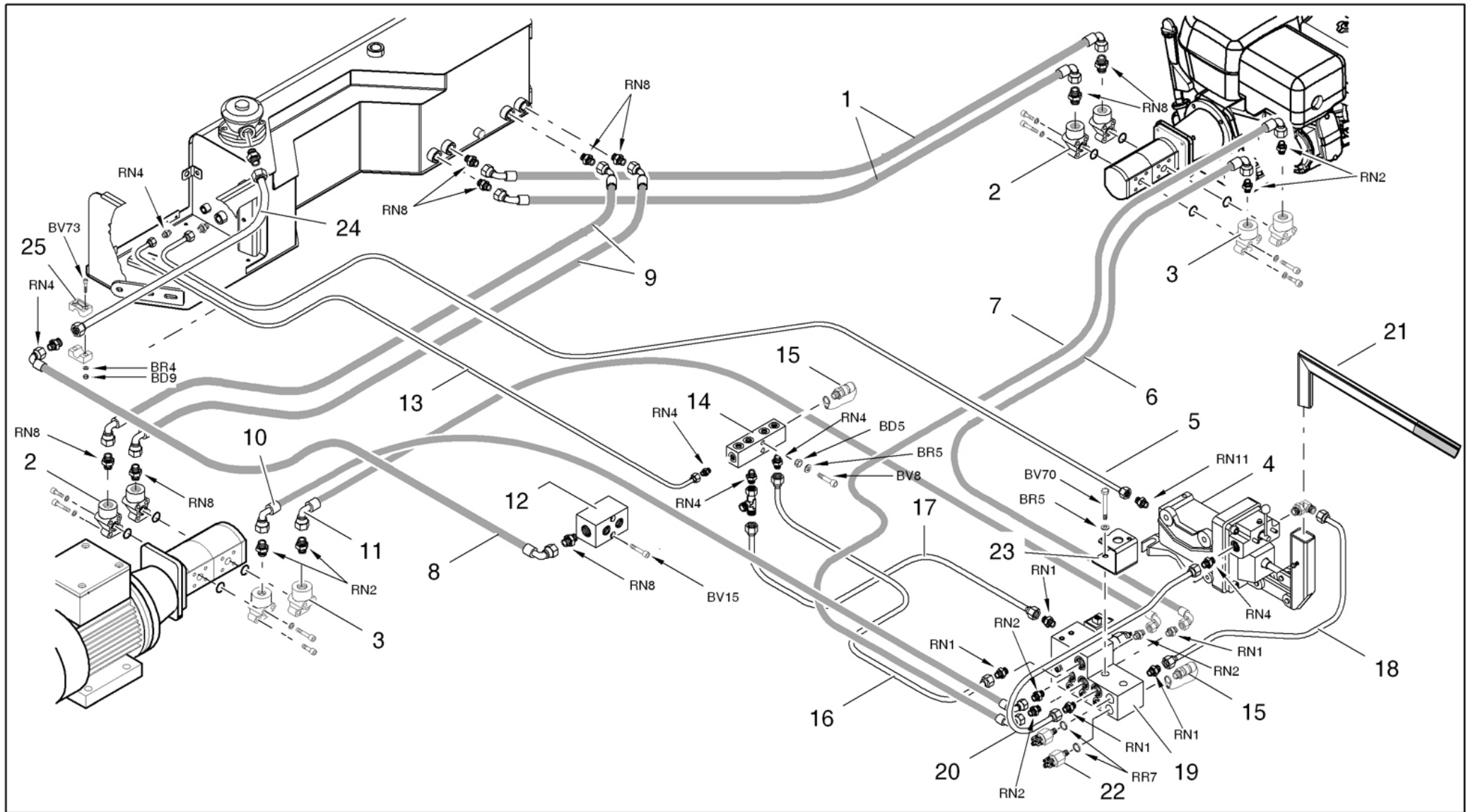
HYDRAULIKANLAGE VORLÄUFE UND RÜCKLAUF 
 INSTALACIÓN HIDRÁULICA IMPULSIONES Y DESCARGA 



Main color codes:  J1 - JLG Cream,  J2 - JLG Orange,  C4 - Green



 IMPIANTO IDRAULICO MANDATE E SCARICO

 SUPPLY AND DISCHARGE HYDRAULIC SYSTEM

 SYSTÈME HYDRAULIQUE REFOULEMENT ET DÉCHARGEME

 HYDRAULIKANLAGE VORLÄUFE UND RÜCKLAUF



 INSTALACIÓN HIDRÁULICA IMPULSIONES Y DESCARGA





POS	Codice	 Descrizione	 Description	 Designation	 Benennung	 Descripción
1	07301500	TUBO FLESSIBILE	FLEXIBLE PIPE	TUYAU FLEXIBLE	SCHLAUCH	TUBO FLEXIBLE
2	04845400	FLANGIA 1/2"G	FLANGE 1/2"G	BRIDE 1/2"G	FLANSCH 1/2"G	BRIDA 1/2"G
3	04048100	FLANGIA 3/8" G	FLANGE 3/8" G	BRIDE 3/8" G	FLANSCH 3/8" G	BRIDA 3/8" G
4	26459400	POMPA A MANO	HAND PUMP	POMPE MANUELLE	HANDPUMPE	BOMBA DE MANO
5	07267600	TUBO RIGIDO	RIGID PIPE	TUYAU RIGIDE	ROHR	TUBO RÍGIDO
6	07301900	TUBO FLESSIBILE	FLEXIBLE PIPE	TUYAU FLEXIBLE	SCHLAUCH	TUBO FLEXIBLE
7	07302000	TUBO FLESSIBILE	FLEXIBLE PIPE	TUYAU FLEXIBLE	SCHLAUCH	TUBO FLEXIBLE
8	07301700	TUBO FLESSIBILE	FLEXIBLE PIPE	TUYAU FLEXIBLE	SCHLAUCH	TUBO FLEXIBLE
9	07301600	TUBO FLESSIBILE	FLEXIBLE PIPE	TUYAU FLEXIBLE	SCHLAUCH	TUBO FLEXIBLE
10	07302100	TUBO FLESSIBILE	FLEXIBLE PIPE	TUYAU FLEXIBLE	SCHLAUCH	TUBO FLEXIBLE
11	07302200	TUBO FLESSIBILE	FLEXIBLE PIPE	TUYAU FLEXIBLE	SCHLAUCH	TUBO FLEXIBLE
12	05497500	BLOCCHETTO TUBI	HOSES BLOCK	BLOC TUYAUX	ROHRBLOCK	BLOQUE TUBOS
13	07267500	TUBO RIGIDO	RIGID PIPE	TUYAU RIGIDE	ROHR	TUBO RÍGIDO
14	04707700	COLLETTORE	MANIFOLD	COLLECTEUR	KOLLEKTOR	COLECTOR
15	03014400	PROVA PRESSIONE 1/4" G	PRESSURE TEST 1/4" G	PREUVE PRESSION 1/4" G	DRUCKKONTROLLE 1/4" G	PRUEBA PRESIÓN 1/4" G
16	07267400	TUBO RIGIDO	RIGID PIPE	TUYAU RIGIDE	ROHR	TUBO RÍGIDO
16	07502700	TUBO RIGIDO	RIGID PIPE	TUYAU RIGIDE	ROHR	TUBO RÍGIDO
17	07345600	TUBO RIGIDO	RIGID PIPE	TUYAU RIGIDE	ROHR	TUBO RÍGIDO
18	07267100	TUBO RIGIDO	RIGID PIPE	TUYAU RIGIDE	ROHR	TUBO RÍGIDO
19	16478200	VALVOLA IDRAULICA	HYDRAULIC VALVE	VALVE HYDRAULIQUE	HYDRAULIKVENTIL	VÁLVULA HIDRÁULICA
20	07267200	TUBO RIGIDO	RIGID PIPE	TUYAU RIGIDE	ROHR	TUBO RÍGIDO
21	16517700	LEVA	LEVER	LEVIER	HEBEL	PALANCA
22	26964400	PRESSOSTATO	PRESSURE SWITCH	PRESSOSTAT	DRUCKSCHALTER	PRESÓSTATO
23	07268800	SUPPORTO	SUPPORT	SOUTIEN	SUPPORT	APOYO
23	075025Y1	SUPPORTO	SUPPORT	SOUTIEN	SUPPORT	APOYO
24	07267000	TUBO RIGIDO	RIGID PIPE	TUYAU RIGIDE	ROHR	TUBO RÍGIDO
25	04096900	MORSETTO	CLAMP	ÉTAU	KLEMME	ABRAZADERA

 IMPIANTO IDRAULICO MANDATE E SCARICO

 SUPPLY AND DISCHARGE HYDRAULIC SYSTEM

 SYSTÈME HYDRAULIQUE REFOULEMENT ET DÉCHARGEMENT

 HYDRAULIKANLAGE VORLÄUFE UND RÜCKLAUF 
 INSTALACIÓN HIDRÁULICA IMPULSIONES Y DESCARGA 

POS	Codice	 Descrizione	 Description	 Designation	 Benennung	 Descripción
1	27299100	DISTRIBUTORE LC STABILIZZATORI- TRAINO 4 ELEMENTI CON LEVE EMERGENZA A PULSANTE	HYDRAULIC DISTRIBUTOR STABILIZERS-TRACKS 4 PARTS WITH LEVERS EMERGENCY BUTTON	DISTRIBUTEUR HYDRAULIQUE	HYDRAULIKVENTILB LOCK	DISTRIBUIDOR HIDRÁULICO
2	07269300	TUBO RIGIDO	RIGID PIPE	TUYAU RIGIDE	ROHR	TUBO RÍGIDO
3	07302800	TUBO FLESSIBILE	FLEXIBLE PIPE	TUYAU FLEXIBLE	SCHLAUCH	TUBO FLEXIBLE
4	27299000	DISTRIBUTORE LC STABILIZZATORI- TRAINO 3 ELEMENTI CON LEVE EMERGENZA A PULSANTE	HYDRAULIC DISTRIBUTOR STABILIZERS-TRACKS 3 PARTS WITH LEVERS EMERGENCY BUTTON	DISTRIBUTEUR HYDRAULIQUE	HYDR. REGELSTEUERGERÄT	DISTRIBUIDOR HIDRÁULICO
5	07269200	TUBO RIGIDO	RIGID PIPE	TUYAU RIGIDE	ROHR	TUBO RÍGIDO
6	07302900	TUBO FLESSIBILE	FLEXIBLE PIPE	TUYAU FLEXIBLE	SCHLAUCH	TUBO FLEXIBLE
7	25908400	DISPOSITIVO DI COMANDO MANUALE IDRAULICO	HAND CONTROL HYDRAULIC	COMMANDE HYDRAULIQUE	HYDRAULISCHER ANTRIEB	COMANDO HIDRÁULICO
7	28140600	DISPOSITIVO DI COMANDO MANUALE IDRAULICO NEW SOLENOID CONCEPT	HAND CONTROL HYDRAULIC NEW SOLENOID CONCEPT	COMMANDE HYDRAULIQUE	HYDRAULISCHER ANTRIEB	COMANDO HIDRÁULICO
8	25732900	DEVIATORE IDRAULICO	HYDRAULIC DIVERTER	DÈVIATEUR	WECHSELSCHLTER	DESVIADOR
9	27323500	DISTRIBUTORE IDRAULICO 7 ELEMENTI PARTE AEREA CON PULSANTE	HYDRAULIC DISTRIBUTOR 7 ELEMENTS AERIAL PART WITH BUTTON	DISTRIBUTEUR HYDRAULIQUE	HYDRAULISCHER VERTEILER	DISTRIBUIDOR HIDRÁULICO





 IMPIANTO IDRAULICO MANDATE E SCARICO



 SUPPLY AND DISCHARGE HYDRAULIC SYSTEM



 SYSTÈME HYDRAULIQUE REFOULEMENT ET DÉCHARGEMENT

 HYDRAULIKANLAGE VORLÄUFE UND RÜCKLAUF



 INSTALACIÓN HIDRÁULICA IMPULSIONES Y DESCARGA



POS	Codice	 Descrizione	 Description	 Designation	 Benennung	 Descripció
9	27533400	DISTRIBUTORE IDRAULICO 7 ELEMENTI PARTE AEREA CON PULSANTE (FOR LL1775-X17JP-X500AJ-LL2010-X20JP-X600AJ MK2 FROM C170000893)	HYDRAULIC DISTRIBUTOR 7 ELEMENTS AERIAL PART WITH BUTTON (FOR LL1775-X17JP-X500AJ-LL2010-X20JP-X600AJ MK2 FROM C170000893)	DISTRIBUTEUR HYDRAULIQUE (FOR LL1775-X17JP-X500AJ-LL2010-X20JP-X600AJ MK2 FROM C170000893)	HYDRAULISCHER VERTEILER (FOR LL1775-X17JP-X500AJ-LL2010-X20JP-X600AJ MK2 FROM C170000893)	DISTRIBUIDOR HIDRÁULICO (FOR LL1775-X17JP-X500AJ-LL2010-X20JP-X600AJ MK2 FROM C170000893)
10	07302400	TUBO FLESSIBILE	FLEXIBLE PIPE	TUYAU FLEXIBLE	SCHLAUCH	TUBO FLEXIBLE
11	07302600	TUBO FLESSIBILE	FLEXIBLE PIPE	TUYAU FLEXIBLE	SCHLAUCH	TUBO FLEXIBLE
12	07267300	TUBO RIGIDO	RIGID PIPE	TUYAU RIGIDE	ROHR	TUBO RÍGIDO
12	07502600	TUBO RIGIDO	RIGID PIPE	TUYAU RIGIDE	ROHR	TUBO RÍGIDO
13	07302700	TUBO FLESSIBILE	FLEXIBLE PIPE	TUYAU FLEXIBLE	SCHLAUCH	TUBO FLEXIBLE
14	07302500	TUBO FLESSIBILE	FLEXIBLE PIPE	TUYAU FLEXIBLE	SCHLAUCH	TUBO FLEXIBLE
15	07302300	TUBO FLESSIBILE	FLEXIBLE PIPE	TUYAU FLEXIBLE	SCHLAUCH	TUBO FLEXIBLE
16	26062200	ACCUMULATORE	ACCUMULATOR	ACCUMULTEUR	AKKUMULATOR	ACUMULADOR
17	07057000	RACCORDO	FITTING	RACCORD	ANSCHLUSS	CONEXIÓN
18	1647820003	ELETTROVALVOLA	SOLENOID VALVE	ÉLECTROVANNE	MAGNETVENTIL	ELECTROVÁLVULA
20	1647820001	VALVOLA IDRAULICA	HYDRAULIC VALVE	VALVE HYDRAULIQUE	HYDRAULIKVENTIL	VÁLVULA HIDRÁULICA
21	36470800	SUPPORTO	SUPPORT	SUPPORT	HALTERUNG	SOPORTE



 DISTRIBUTORI IDRAULICI
 HYDRAULIC DISTRIBUTORS
 DISTRIBUTEURS HYDRAULIQUES





HYDRAULISCHE REGELSTEUERGERÄTE 
DISTRIBUIDORES HIDRÁULICOS 



POS	Codice	 Descrizione	 Description	 Designation	 Benennung	 Descripción
1	2666800007	SEZIONE DISTRIBUTORE ROTAZIONE AEREA AB CHIUSO	CONTROL VALVE SECTION AERIAL ROTATION AB CLOSED	CORPS	GEHÄUSE	CUERPO
2	07325200	VALVOLA PROPORZIONALE (CARTUCCIA) PARTE AEREA PIATTAFORME CON RITORNO A MOLLA COMPLETA DI PULSANTE	PROPORTIONAL VALVE AERIAL PARTS WITH SPRING RETURN COMPLETE BUTTON	SOUPAPE PROPORTIONELLE	PROPORTIONALVENT IL	VALVULA PROPORCIONAL
3	06037900	BOBINA PER VALVOLA PROPORZIONALE PARTE AEREA	COIL PROPORTIONAL VALVE FOR AERIAL PART	BOBINE	SPULE	BOBINA
4	2719290001	SEZIONE DISTRIBUTORE SOLO CORPO METALLICO	CONTROL VALVE SECTION ONLY METAL BODY	CORPS	GEHÄUSE	CUERPO
5	2645900005	SEZIONE DISTRIBUTORE AB CHIUSO CON LEVA (LATO A) E BOBINA	VALVE BLOCK SECTION AB CLOSED WITH LEVER (SIDE A) AND COIL	SECTION DISTRIBUTEUR	VENTILBLOCKSEKTIO N	SECCIÓN DISTRIBUIDOR
6	07324900	COMANDO MANUALE EMERGENZA CON RITORNO A MOLLA	EMERGENCY MAUAL CONTROL WITH SPRING RETURN	COMMANDE MANUEL D'URGENCE	MANUELLES ANTRIEB FÜR NOTSTAND	MANDO MANUAL DE EMERGENCIA
7	2645900006	SEZIONE DISTRIBUTORE ABT CON LEVA (LATO A) E BOBINA	VALVE BLOCK SECTION ABT WITH LEVER (SIDE A) AND COIL	SECTION DISTRIBUTEUR	VENTILBLOCKSEKTIO N	SECCIÓN DISTRIBUIDOR
8	2645900002	CARTUCCIA VALVOLA DI MASSIMA PRESSIONE	CARTRIDGE PRESSURE RELIEF VALVE	CARTOUCHE SOUPAPE DE SÉCURITÉ	PARTONE ÜBERDRUCKVENTIL	CATUCHO VÁLVULA LIMITADORA DE PRESIÓN



Main color codes:  J1 - JLG Cream,  J2 - JLG Orange,  C4 - Green





 DISTRIBUTORI IDRAULICI
 HYDRAULIC DISTRIBUTORS
 DISTRIBUTEURS HYDRAULIQUES

HYDRAULISCHE REGELSTEUERGERÄTE 
DISTRIBUIDORES HIDRÁULICOS 

POS	Codice	 Descrizione	 Description	 Designation	 Benennung	 Descripción
10	2666800005	SEZIONE DISTRIBUTORE AB CHIUSO CON LEVA (LATO B 180°) E BOBINA	SECTION DISTRIBUTOR AB CHIUSO WITH LEVER (SIDE B 180°) AND COIL	CORPS	GEHÄUSE	CUERPO
11	2729900001	VALVOLA PROPORZIONALE TRAINI CON BOBINA E SENZA COMANDO MANUALE A MOLLA	PROPORTIONAL VALVE FOR TRACK WITH COIL AND WITHOUT MANUAL SPRING	SOUPAPE PROPORTIONELLE	PROPORTIONALVENTIL	VÁLVULA PROPORCIONAL
16	2585560004	BLOCCO VALVOLA BILANCIAMENTO BRACCI SU DISTRIBUTORI PARTE AEREA	BALANCING VALVE BLOCK BOOMS OF DISTRIBUTORS AERIAL PART	BLOC SOUPAPE	VENTILSPERRE	BLOQUE VÁLVULA
21	06037100	BOBINA PER VALVOLA PROPORZIONALE PARTE CARRO	COIL PROPORTIONAL VALVE FOR UNDERCARRIAGE	BOBINE	SPULE	BOBINA
22	05913800	BOBINA PER ON-OFF	COIL FOR ON-OFF	BOBINE	SPULE	BOBINA
23	07300200	LEVA DISTRIBUTORE	LEVER HYDRAULIC DISTRIBUTOR	LEVIER	HEBEL	PALANCA
24	2585560005	O-RING	O-RING	O-RING	O-RING	O-RING
25	1730720001	ELETTROVALVOLA ON-OFF CON LED	SOLENOID ON-OFF WITH LED	ELECTROVANNE ON-OFF AVEC LED	SOLENOID ON-OFF WITH LED	SOLENOIDE ON-OFF CON LED
26	2666800006	SEZIONE DISTRIBUTORE ABT CON LEVA (LATO B 180°) E BOBINA	SECTION DISTRIBUTOR ABT WITH LEVER (SIDE B 180°) AND COIL	CORPS	GEHÄUSE	CUERPO

 DISTRIBUTORI IDRAULICI
 HYDRAULIC DISTRIBUTORS
 DISTRIBUTEURS HYDRAULIQUES

HYDRAULISCHE REGELSTEUERGERÄTE 
DISTRIBUIDORES HIDRÁULICOS 

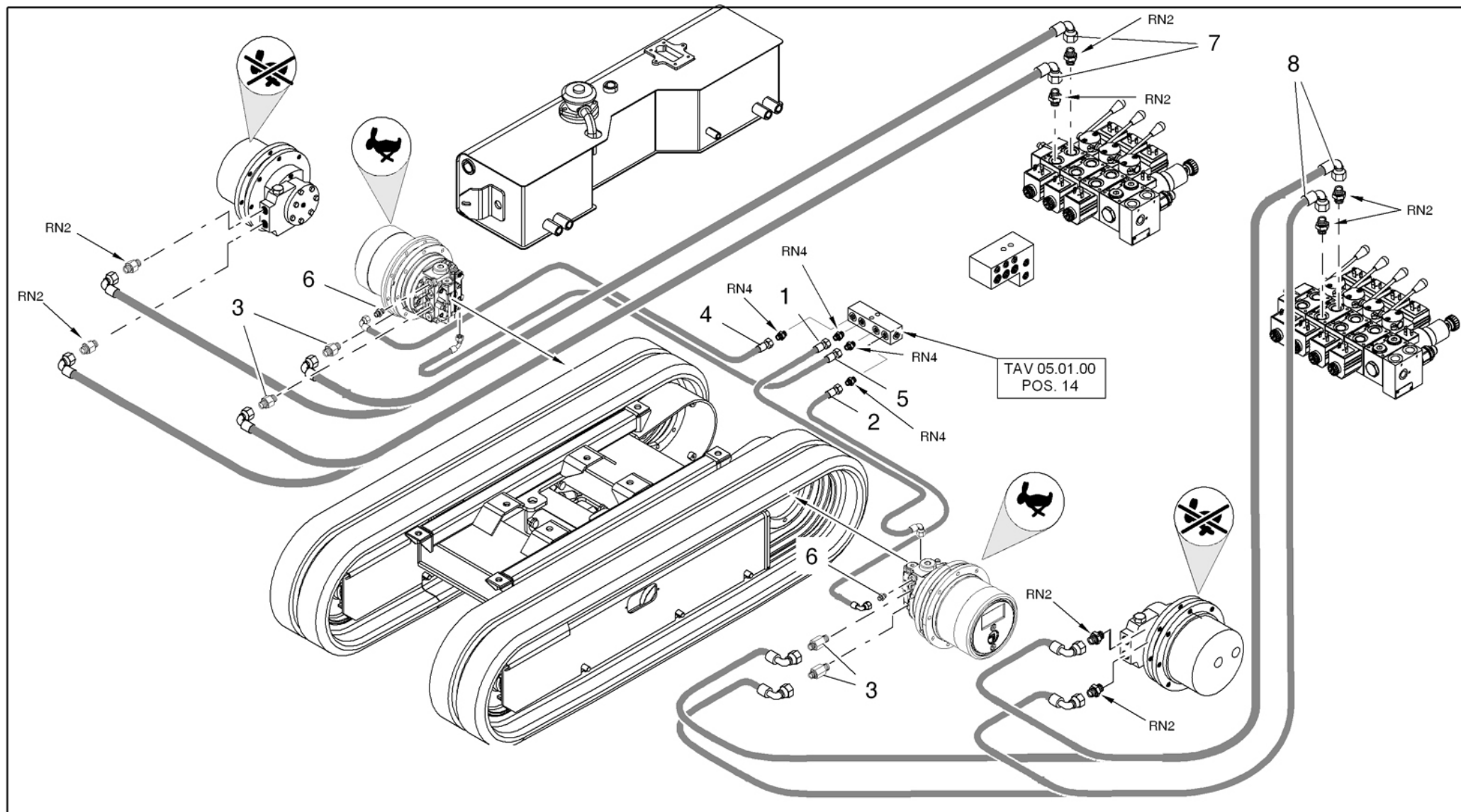

POS	Codice	 Descrizione	 Description	 Designation	 Benennung	 Descripción
26	2753340004	ELEMENTO DISTRIBUTORE COMPLETO DI PROPORZIONALE PARTE AEREA CON LEVA ROSSA (LATO 1)	VALVE BLOCK ELEMENT	ELEMENT DISTRIBUTEUR	VENTILBLOCKSATZ	ELEMENTO DISTRIBUIDOR
27	2753340003	LEVA ROSSA DISTRIBUTORE	RED LEVER HYDRAULIC DISTRIBUTOR	LEVIER	HEBEL	PALANCA
28	2753340001	SEZIONE DISTRIBUTORE AB CHIUSO CON LEVA (LATO 1) E BOBINA	SECTION DISTRIBUTOR AB CLOSED WITH LEVER (SIDE 1) AND COIL	SECTION DISTRIBUTEUR	VENTILBLOCKSEKTIO N	SECCIÓN DISTRIBUIDOR
29	2753340002	SEZIONE DISTRIBUTORE ABT CON LEVA (LATO 1) E BOBINA	SECTION DISTRIBUTOR ABT WITH LEVER (SIDE 1) AND COIL	SECTION DISTRIBUTEUR	VENTILBLOCKSEKTIO N	SECCIÓN DISTRIBUIDOR











 IMPIANTO IDRAULICO TRAZIONE



 HYDRAULIC SYSTEM FOR TRACTION

 SYSTÈME HYDRAULIQUE DE TRACTION



 HYDRAULIKANLAGE ANTRIEB 
 INSTALACIÓN HIDRÁULICA TRACCIÓN 



POS	Codice	 Descrizione	 Description	 Designation	 Benennung	 Descripción
1	07305000	TUBO FLESSIBILE	FLEXIBLE PIPE	TUYAU FLEXIBLE	SCHLAUCH	TUBO FLEXIBLE
2	07304900	TUBO FLESSIBILE	FLEXIBLE PIPE	TUYAU FLEXIBLE	SCHLAUCH	TUBO FLEXIBLE
3	05093900	RACCORDO 12L-3/8 JIS ESAGONO 22 H40	12L-FITTING 3/8 JIS HEX22 H40	RACCORD	ANSCHLUSS	CONEXIÓN
4	07305100	TUBO FLESSIBILE	FLEXIBLE PIPE	TUYAU FLEXIBLE	SCHLAUCH	TUBO FLEXIBLE
5	07304800	TUBO FLESSIBILE	FLEXIBLE PIPE	TUYAU FLEXIBLE	SCHLAUCH	TUBO FLEXIBLE
6	05093800	RACCORDO	FITTING	RACCORD	ANSCHLUSS	CONEXIÓN
7	07300900	TUBO FLESSIBILE	FLEXIBLE PIPE	TUYAU FLEXIBLE	SCHLAUCH	TUBO FLEXIBLE
8	07300800	TUBO FLESSIBILE	FLEXIBLE PIPE	TUYAU FLEXIBLE	SCHLAUCH	TUBO FLEXIBLE

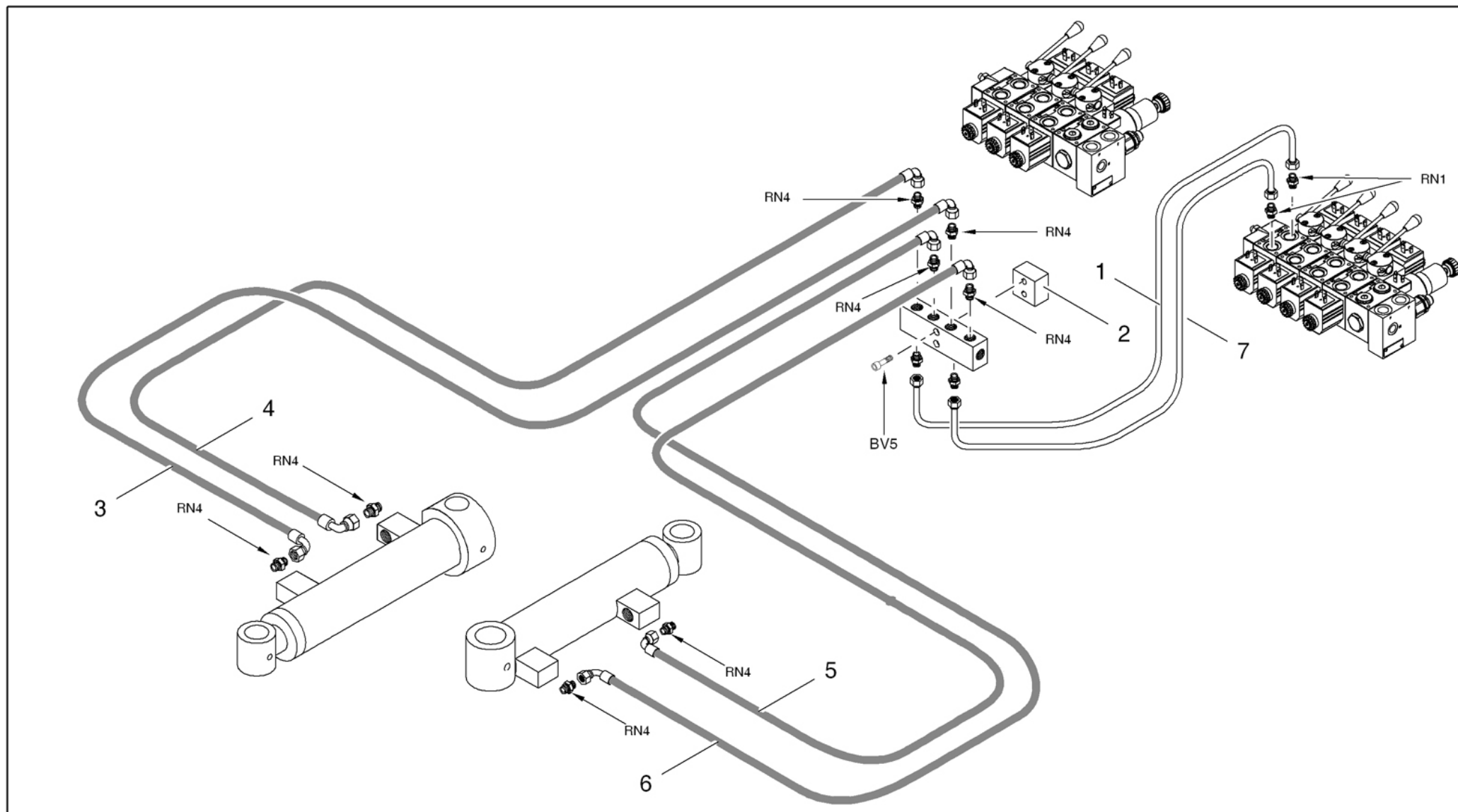

 IMPIANTO IDRAULICO ALLARGAMENTO CARRO
 HYDRAULIC SYSTEM UNDERCARRIAGE EXPANSION
 SYSTÈME HYDRAULIQUE EXTENSION DU CHARIOT





HYDRAULIKANLAGE VERBREITERUNG WAGEN 
 INSTALACIÓN HIDRAULICA ENSANCHAMIENTO CARRO 



Main color codes:  **J1** - JLG Cream,  **J2** - JLG Orange,  **C4** - Green

 IMPIANTO IDRAULICO ALLARGAMENTO CARRO
 HYDRAULIC SYSTEM UNDERCARRIAGE EXPANSION
 SYSTÈME HYDRAULIQUE EXTENSION DU CHARIOT

HYDRAULIKANLAGE VERBREITERUNG WAGEN 
 INSTALACIÓN HIDRAULICA ENSANCHAMIENTO CARRO 

POS	Codice	 Descrizione	 Description	 Designation	 Benennung	 Descripción
1	07269400	TUBO RIGIDO	RIGID PIPE	TUYAU RIGIDE	ROHR	TUBO RÍGIDO
2	07172500	DISTANZIALE	SPACER	ENTRETOISE	DISTANZSCHEIBE	SEPARADOR
3	07301200	TUBO FLESSIBILE	FLEXIBLE PIPE	TUYAU FLEXIBLE	SCHLAUCH	TUBO FLEXIBLE
4	07301300	TUBO FLESSIBILE	FLEXIBLE PIPE	TUYAU FLEXIBLE	SCHLAUCH	TUBO FLEXIBLE
5	07301100	TUBO FLESSIBILE	FLEXIBLE PIPE	TUYAU FLEXIBLE	SCHLAUCH	TUBO FLEXIBLE
6	07301000	TUBO FLESSIBILE	FLEXIBLE PIPE	TUYAU FLEXIBLE	SCHLAUCH	TUBO FLEXIBLE
7	07269500	TUBO RIGIDO	RIGID PIPE	TUYAU RIGIDE	ROHR	TUBO RÍGIDO

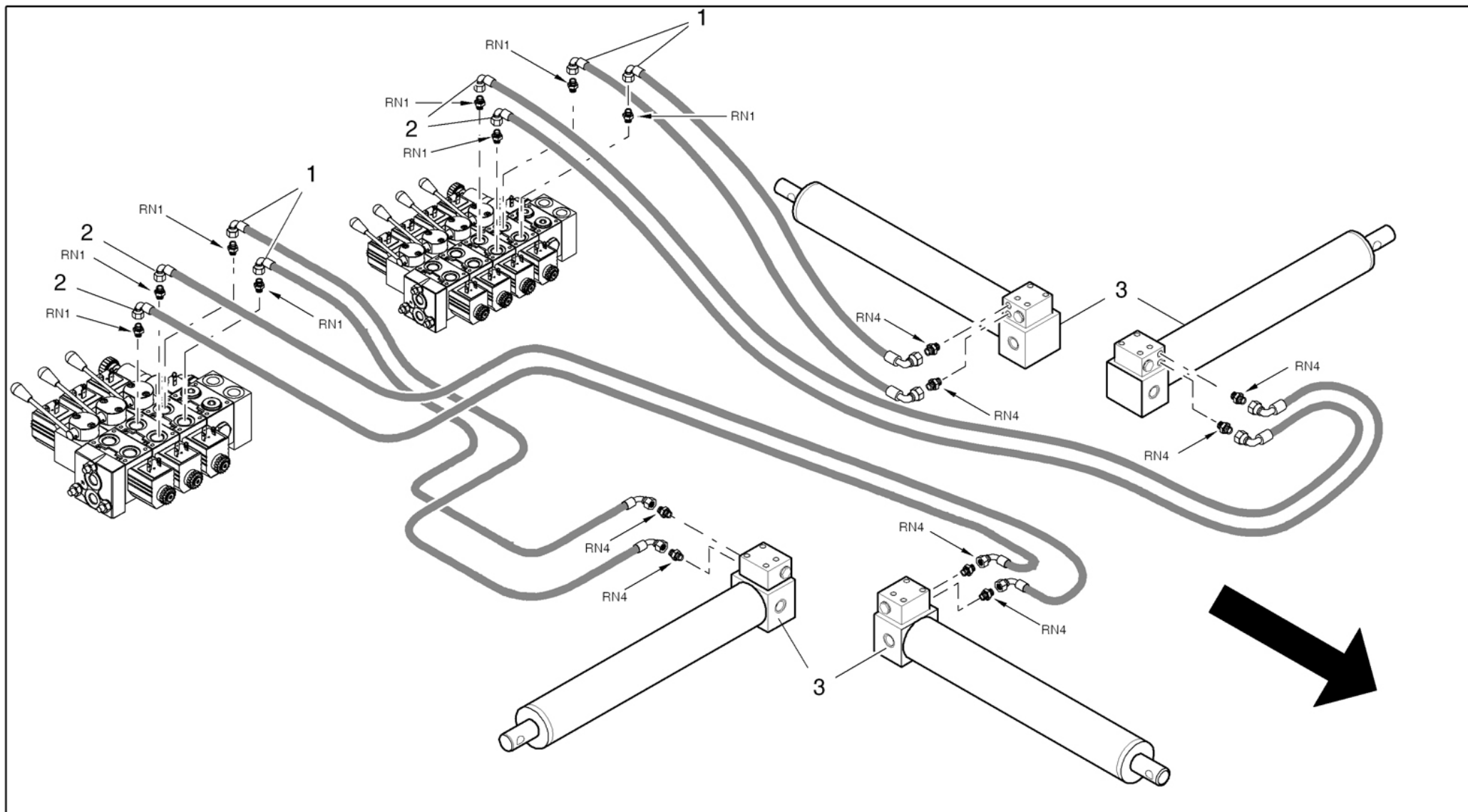





 IMPIANTO IDRAULICO STABILIZZATORI



 STABILIZERS HYDRAULIC SYSTEM

 INSTALLATION HYDRAULIQUE STABILISATERS

 ABSTÜTZUNG ABSTÜTZUNGSHYDRAULIKZYLIND

 INSTALACIÓN HIDRAULICA ESTABILIZADORS

POS	Codice	 Descrizione	 Description	 Designation	 Benennung	 Descripción
1	07301400	TUBO FLESSIBILE	FLEXIBLE PIPE	TUYAU FLEXIBLE	SCHLAUCH	TUBO FLEXIBLE
2	07301800	TUBO FLESSIBILE	FLEXIBLE PIPE	TUYAU FLEXIBLE	SCHLAUCH	TUBO FLEXIBLE
3	27226100	CILINDRO STABILIZZATORE LL2010	CYLINDER OUTRIGGER	DÉTENDEUR DE LA BOUTEILLE LL2010	FLASCHENDRUCKMI NDERER LL2010	CILINDRO ESTABILIZADOR LL2010
3	272261A3	CILINDRO STABILIZZATORE LL2010	CYLINDER OUTRIGGER	DÉTENDEUR DE LA BOUTEILLE LL2010	FLASCHENDRUCKMI NDERER LL2010	CILINDRO ESTABILIZADOR LL2010
3	272261H2	CILINDRO STABILIZZATORE LL2010	CYLINDER OUTRIGGER	DÉTENDEUR DE LA BOUTEILLE LL2010	FLASCHENDRUCKMI NDERER LL2010	CILINDRO ESTABILIZADOR LL2010



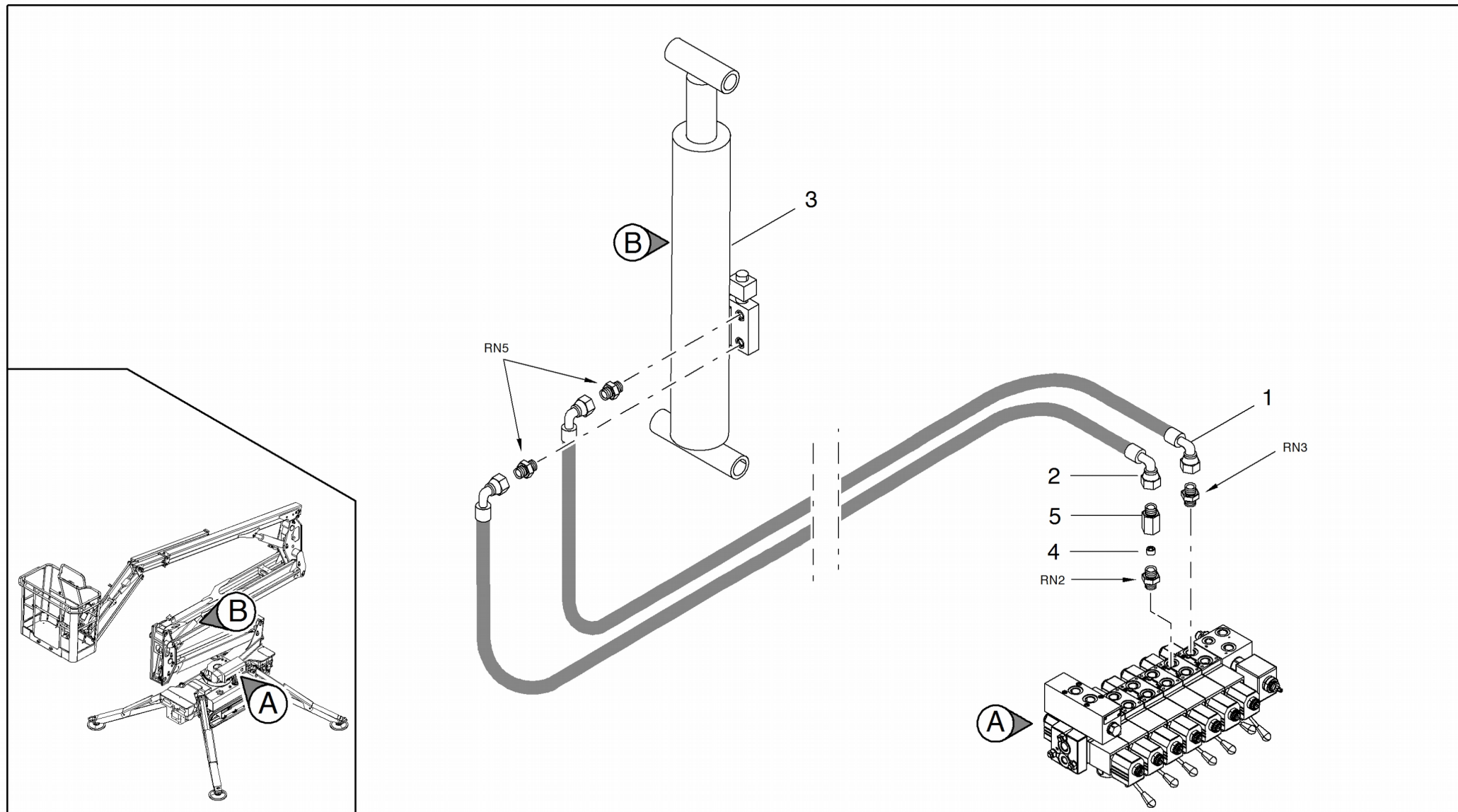

Main color codes:  J1 - JLG Cream,  J2 - JLG Orange,  C4 - Green







 IMPIANTO IDRAULICO 1-2 BRACCI

 1-2 ARMS HYDRAULIC SYSTEM



 SYSTÈME HYDRAULIQUE 1-2 BRAS
HYDRAULIKANLAGE 1-2 ARM INSTALACIÓN HIDRÁULICA 1-2 BRAZOS 

POS	Codice	 Descrizione	 Description	 Designation	 Benennung	 Descripción
1	07303000	TUBO FLESSIBILE	FLEXIBLE PIPE	TUYAU FLEXIBLE	SCHLAUCH	TUBO FLEXIBLE
1	07722300	TUBO FLESSIBILE MK2 (FROM C170000893)	FLEXIBLE PIPE MK2 (FROM C170000893)	TUYAU FLEXIBLE MK2 (FROM C170000893)	SCHLAUCH MK2 (FROM C170000893)	TUBO FLEXIBLE MK2 (FROM C170000893)
2	07303100	TUBO FLESSIBILE	FLEXIBLE PIPE	TUYAU FLEXIBLE	SCHLAUCH	TUBO FLEXIBLE
2	07722400	TUBO FLESSIBILE MK2 (FROM C170000893)	FLEXIBLE PIPE MK2 (FROM C170000893)	TUYAU FLEXIBLE MK2 (FROM C170000893)	SCHLAUCH MK2 (FROM C170000893)	TUBO FLEXIBLE MK2 (FROM C170000893)
3	27225900	CILINDRO 1° E 2° BRACCIO	FIRST AND SECOND ARM CYLINDER	CYLINDRE 1IER ET 2ÈME BRAS	ZYLINDER 1. U. 2. ARM	CILINDRO PRIMERO Y SEGUNDO BRAZO
3	272259A3	CILINDRO 1° E 2° BRACCIO	FIRST AND SECOND ARM CYLINDER	CYLINDRE 1IER ET 2ÈME BRAS	ZYLINDER 1. U. 2. ARM	CILINDRO PRIMERO Y SEGUNDO BRAZO
3	272259H2	CILINDRO 1° E 2° BRACCIO	FIRST AND SECOND ARM CYLINDER	CYLINDRE 1IER ET 2ÈME BRAS	ZYLINDER 1. U. 2. ARM	CILINDRO PRIMERO Y SEGUNDO BRAZO
4	07688500	PASTIGLIA VNR STROZZATA 3/8 FORO DA Ø=2MM	VALVE	SOUPAPE	VENTIL	VALVULA
5	07688400	RACCORDO PROLUNGA M-F 3/8 H=30 FILETTO UTILE 25	FITTING	RACCORD	ANSCHLUSS	CONEXIÓN

 IMPIANTO IDRAULICO 3 BRACCIO
 3 ARM HYDRAULIC SYSTEM
 SYSTÈME HYDRAULIQUE 3 BRAS

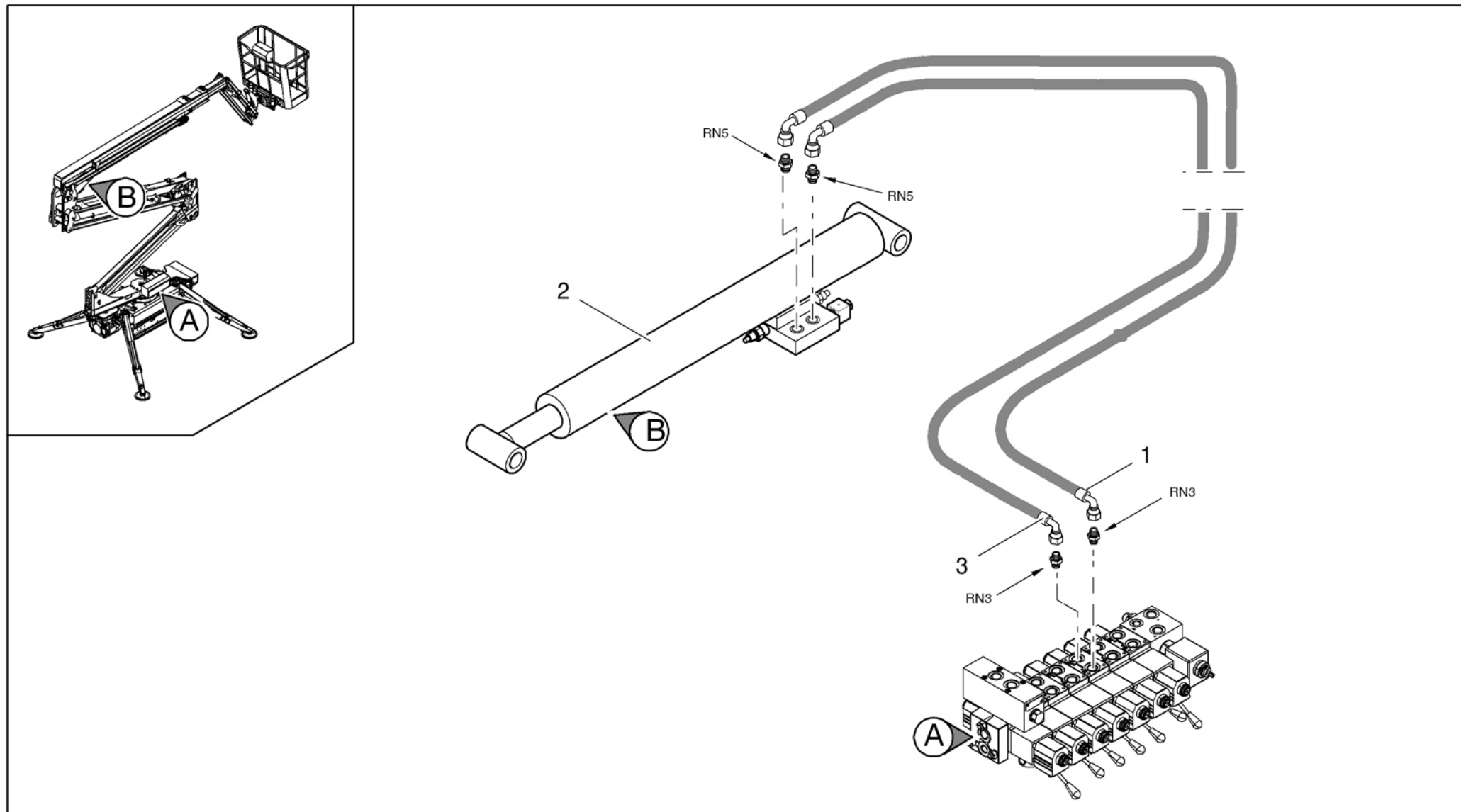
HYDRAULIKANLAGE 3 ARM 
INSTALACIÓN HIDRÁULICA 3 BRAZO 











Main color codes:  J1 - JLG Cream,  J2 - JLG Orange,  C4 - Green



 IMPIANTO IDRAULICO 3 BRACCIO

 3 ARM HYDRAULIC SYSTEM

 SYSTÈME HYDRAULIQUE 3 BRAS
HYDRAULIKANLAGE 3 ARM INSTALACIÓN HIDRÁULICA 3 BRAZO 



POS	Codice	 Descrizione	 Description	 Designation	 Benennung	 Descripción
1	07303500	TUBO FLESSIBILE	FLEXIBLE PIPE	TUYAU FLEXIBLE	SCHLAUCH	TUBO FLEXIBLE
1	07720600	TUBO FLESSIBILE MK2 (FROM C170000893)	FLEXIBLE PIPE MK2 (FROM C170000893)	TUYAU FLEXIBLE MK2 (FROM C170000893)	SCHLAUCH MK2 (FROM C170000893)	TUBO FLEXIBLE MK2 (FROM C170000893)
1	07721600	TUBO FLESSIBILE MK2 (FROM C170000893)	FLEXIBLE PIPE MK2 (FROM C170000893)	TUYAU FLEXIBLE MK2 (FROM C170000893)	SCHLAUCH MK2 (FROM C170000893)	TUBO FLEXIBLE MK2 (FROM C170000893)
2	27226000	CILINDRO 3° BRACCIO	THIRD ARM CYLINDER	CYLINDRE 3ÈME BRAS	ZYLINDER 3. ARM	CILINDRO 3ER BRAZO
2	272260A3	CILINDRO 3° BRACCIO	THIRD ARM CYLINDER	CYLINDRE 3ÈME BRAS	ZYLINDER 3. ARM	CILINDRO 3ER BRAZO
2	272260H2	CILINDRO 3° BRACCIO	THIRD ARM CYLINDER	CYLINDRE 3ÈME BRAS	ZYLINDER 3. ARM	CILINDRO 3ER BRAZO
3	07303400	TUBO FLESSIBILE	FLEXIBLE PIPE	TUYAU FLEXIBLE	SCHLAUCH	TUBO FLEXIBLE
3	07720500	TUBO FLESSIBILE MK2 (FROM C170000893)	FLEXIBLE PIPE MK2 (FROM C170000893)	TUYAU FLEXIBLE MK2 (FROM C170000893)	SCHLAUCH MK2 (FROM C170000893)	TUBO FLEXIBLE MK2 (FROM C170000893)
3	07721500	TUBO FLESSIBILE MK2 (FROM C170000893)	FLEXIBLE PIPE MK2 (FROM C170000893)	TUYAU FLEXIBLE MK2 (FROM C170000893)	SCHLAUCH MK2 (FROM C170000893)	TUBO FLEXIBLE MK2 (FROM C170000893)

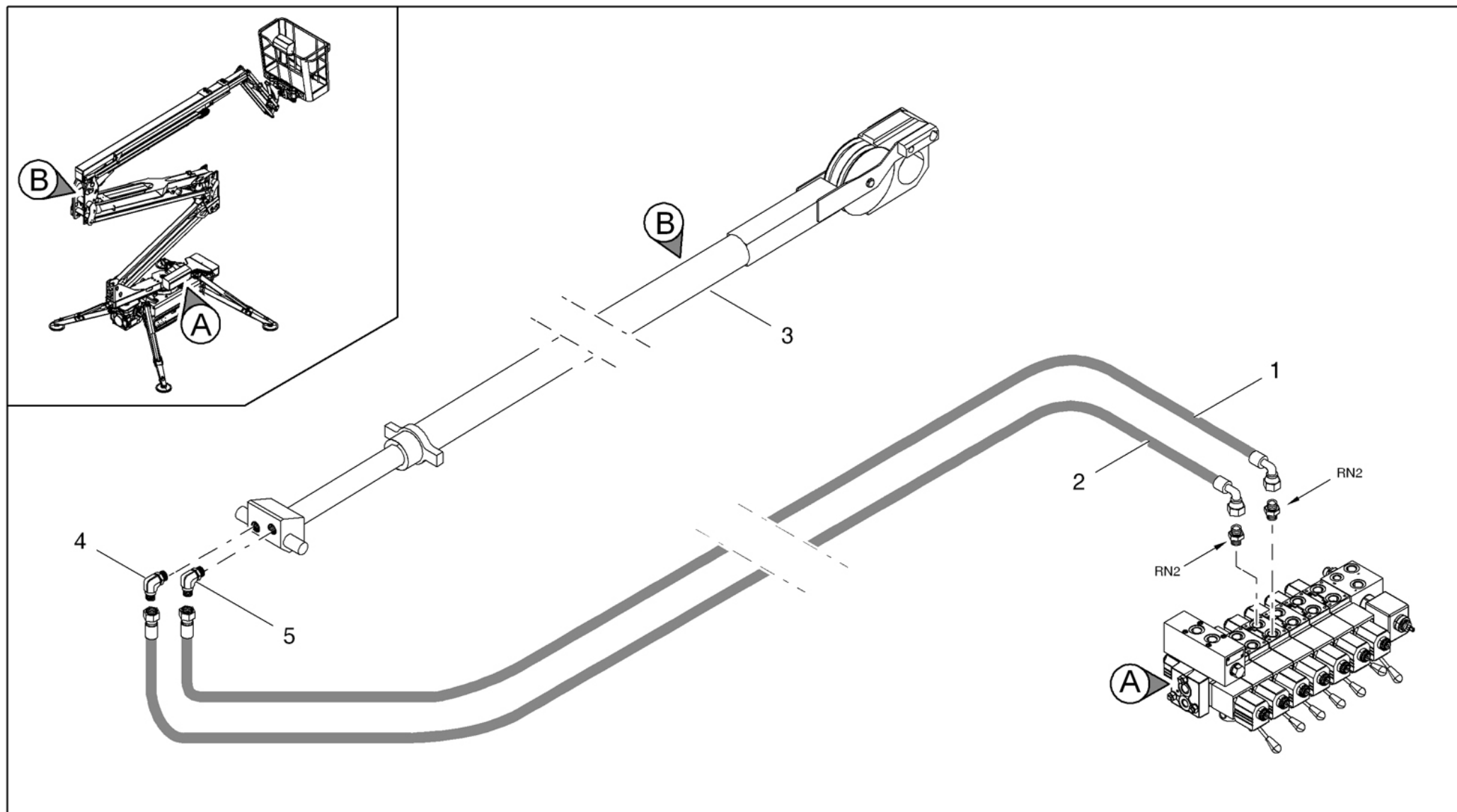

Main color codes:  J1 - JLG Cream,  J2 - JLG Orange,  C4 - Green

-  IMPIANTO IDRAULICO SFILO
-  TELESCOPIC HYDRAULIC SYSTEM
-  TELESCOPIQUE HIDRAULIQUE





TELESKOPHYDRAULIK 
INSTALACIÓN EXTENSIÓN HIDRÁULICA 





Main color codes:  J1 - JLG Cream,  J2 - JLG Orange,  C4 - Green



 IMPIANTO IDRAULICO SFILO
 TELESCOPIC HYDRAULIC SYSTEM
 TELESCOPIQUE HIDRAULIQUE



TELESKOPHYDRAULIK 
 INSTALACIÓN EXTENSIÓN HIDRÁULICA 

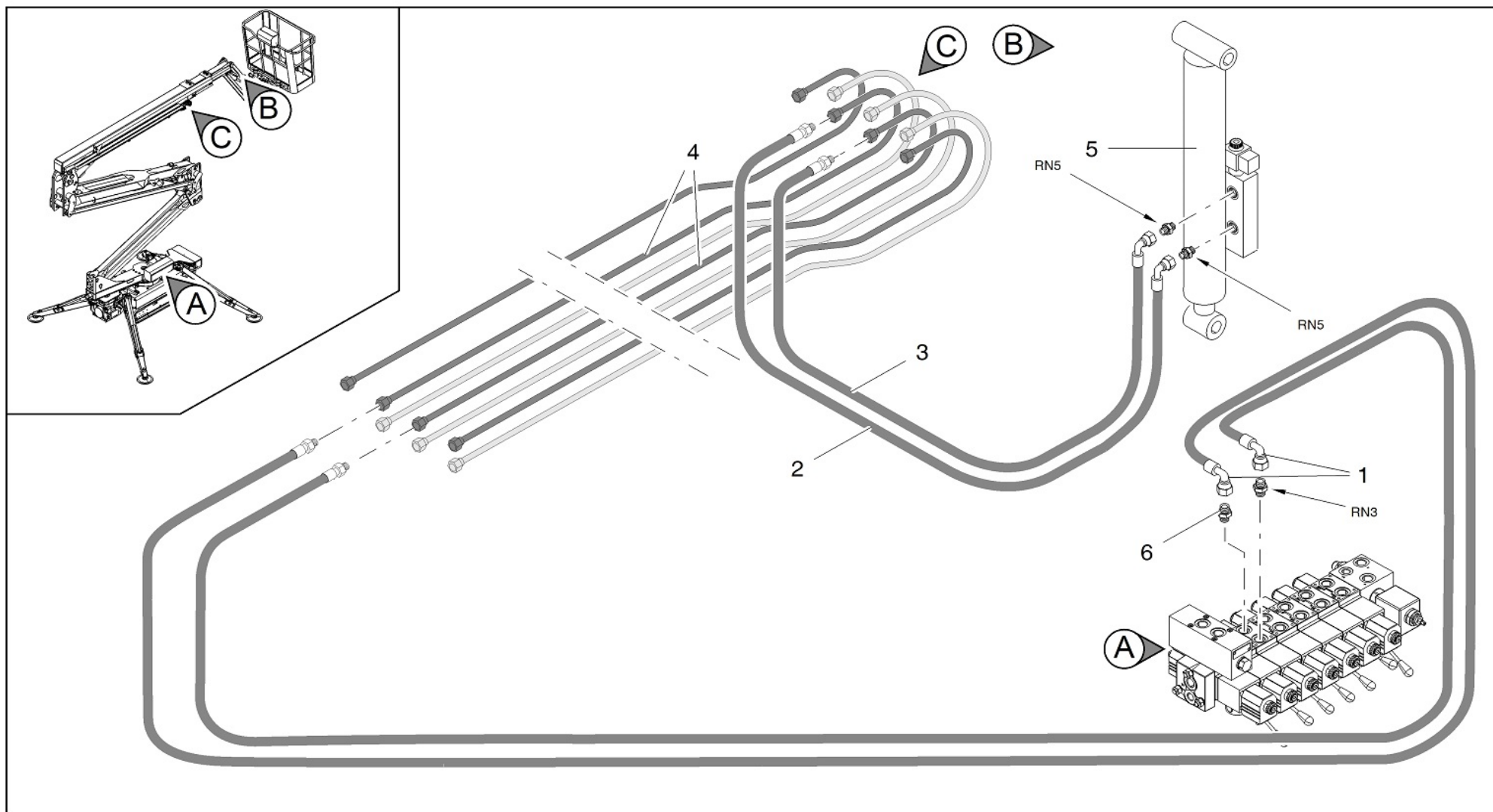



POS	Codice	 Descrizione	 Description	 Designation	 Benennung	 Descripción
1	07304100	TUBO FLESSIBILE	FLEXIBLE PIPE	TUYAU FLEXIBLE	SCHLAUCH	TUBO FLEXIBLE
1	07721200	TUBO FLESSIBILE MK2 (FROM C170000893)	FLEXIBLE PIPE MK2 (FROM C170000893)	TUYAU FLEXIBLE MK2 (FROM C170000893)	SCHLAUCH MK2 (FROM C170000893)	TUBO FLEXIBLE MK2 (FROM C170000893)
1	07722200	TUBO FLESSIBILE MK2 (FROM C170000893)	FLEXIBLE PIPE MK2 (FROM C170000893)	TUYAU FLEXIBLE MK2 (FROM C170000893)	SCHLAUCH MK2 (FROM C170000893)	TUBO FLEXIBLE MK2 (FROM C170000893)
2	07304000	TUBO FLESSIBILE	FLEXIBLE PIPE	TUYAU FLEXIBLE	SCHLAUCH	TUBO FLEXIBLE
2	07721100	TUBO FLESSIBILE MK2 (FROM C170000893)	FLEXIBLE PIPE MK2 (FROM C170000893)	TUYAU FLEXIBLE MK2 (FROM C170000893)	SCHLAUCH MK2 (FROM C170000893)	TUBO FLEXIBLE MK2 (FROM C170000893)
2	07722100	TUBO FLESSIBILE MK2 (FROM C170000893)	FLEXIBLE PIPE MK2 (FROM C170000893)	TUYAU FLEXIBLE MK2 (FROM C170000893)	SCHLAUCH MK2 (FROM C170000893)	TUBO FLEXIBLE MK2 (FROM C170000893)
3	272262H2	CILINDRO SFILO	EXTENSION CYLINDER	EXTENSION DU CYLINDRE	ZYLINDERVERLÄNGE RUNG	EXTENSION DE CILINDRO
4	04995000	RACCORDO	FITTING	RACCORD	ANSCHLUSS	CONEXIÓN
5	05510300	CURVA	CURVE	COURBE	KURVE	CURVA



Main color codes:  J1 - JLG Cream,  J2 - JLG Orange,  C4 - Green







 IMPIANTO JIB
 JIB HYDRAULIC SYSTEM
 SYSTÈME HYDRAULIQUE JIB

ZYLINDER JIB ARM 
 INSTALACIÓN HIDRÁULICA JIB 



POS	Codice	 Descrizione	 Description	 Designation	 Benennung	 Descripcìon
1	07303700	TUBO FLESSIBILE	FLEXIBLE PIPE	TUYAU FLEXIBLE	SCHLAUCH	TUBO FLEXIBLE
1	07720700	TUBO FLESSIBILE MK2 (FROM C170000893)	FLEXIBLE PIPE MK2 (FROM C170000893)	TUYAU FLEXIBLE MK2 (FROM C170000893)	SCHLAUCH MK2 (FROM C170000893)	TUBO FLEXIBLE MK2 (FROM C170000893)
1	07721700	TUBO FLESSIBILE MK2 (FROM C170000893)	FLEXIBLE PIPE MK2 (FROM C170000893)	TUYAU FLEXIBLE MK2 (FROM C170000893)	SCHLAUCH MK2 (FROM C170000893)	TUBO FLEXIBLE MK2 (FROM C170000893)
2	07304300	TUBO FLESSIBILE	FLEXIBLE PIPE	TUYAU FLEXIBLE	SCHLAUCH	TUBO FLEXIBLE
3	07304200	TUBO FLESSIBILE	FLEXIBLE PIPE	TUYAU FLEXIBLE	SCHLAUCH	TUBO FLEXIBLE
4	07266700	TUBO RIGIDO	RIGID PIPE	TUYAU RIGIDE	ROHR	TUBO RÍGIDO
4	07877800	TUBO RIGIDO	RIGID PIPE	TUYAU RIGIDE	ROHR	TUBO RÍGIDO
5	27069500	CILINDRO JIB	JIB CYLINDER	CYLINDRE SECT.TÉLESCOP.	TELESKOPZYLINDER	CIL. BRAZO TELESCÓP.
5	270695A3	CILINDRO SFILO	EXTENSION CYLINDER	CYLINDRE SECT.TÉLESCOP.	TELESKOPZYLINDER	CIL. BRAZO TELESCÓP.
5	270695H2	CILINDRO JIB	JIB CYLINDER	CYLINDRE JIB	KORBARMZYLINDER	CILINDRO JIB
6	06786700	RACCORDO	FITTING	RACCORD	ANSCHLUSS	CONEXIÓN



Main color codes:  J1 - JLG Cream,  J2 - JLG Orange,  C4 - Green

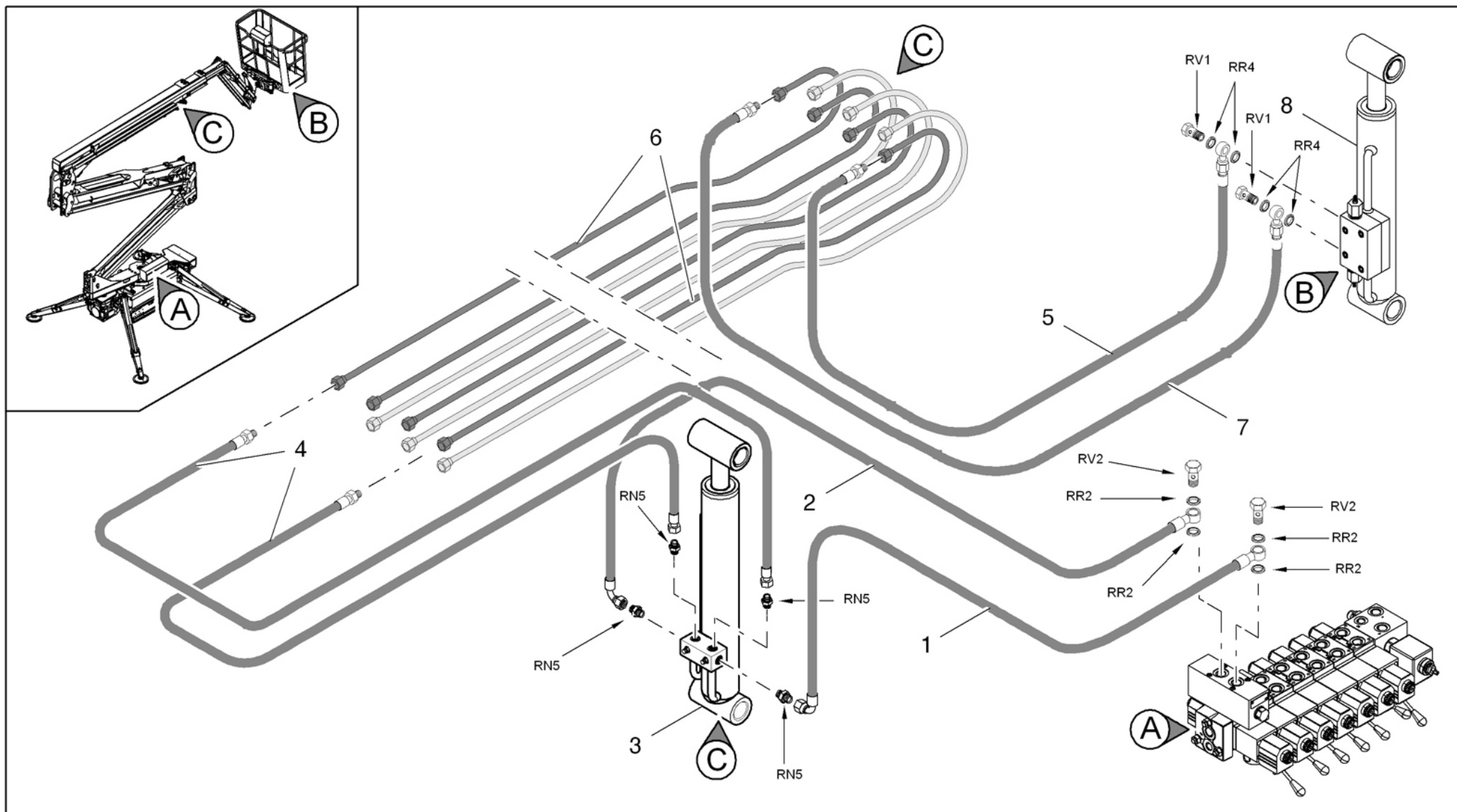

 IMPIANTO IDRAULICO LIVELLAMENTO
 LEVELING CYLINDERS HYDRAULIC SYSTEM
 SYSTÈME HYDRAULIQUE CYLINDRES BRAS





HYDRAULIKANLAGE ZYLINDER ARM 
 INSTALACIÓN HIDRÁULICA CILINDROS BRAZOS 









Main color codes:  J1 - JLG Cream,  J2 - JLG Orange,  C4 - Green



 IMPIANTO IDRAULICO LIVELLAMENTO
 LEVELING CYLINDERS HYDRAULIC SYSTEM
 SYSTÈME HYDRAULIQUE CYLINDRES BRAS





HYDRAULIKANLAGE ZYLINDER ARM 
 INSTALACIÓN HIDRÁULICA CILINDROS BRAZOS 



POS	Codice	 Descrizione	 Description	 Designation	 Benennung	 Descripción
1	07303200	TUBO FLESSIBILE	FLEXIBLE PIPE	TUYAU FLEXIBLE	SCHLAUCH	TUBO FLEXIBLE
1	07720300	TUBO FLESSIBILE MK2 (FROM C170000893)	FLEXIBLE PIPE MK2 (FROM C170000893)	TUYAU FLEXIBLE MK2 (FROM C170000893)	SCHLAUCH MK2 (FROM C170000893)	TUBO FLEXIBLE MK2 (FROM C170000893)
1	07721300	TUBO FLESSIBILE MK2 (FROM C170000893)	FLEXIBLE PIPE MK2 (FROM C170000893)	TUYAU FLEXIBLE MK2 (FROM C170000893)	SCHLAUCH MK2 (FROM C170000893)	TUBO FLEXIBLE MK2 (FROM C170000893)
2	07303300	TUBO FLESSIBILE	FLEXIBLE PIPE	TUYAU FLEXIBLE	SCHLAUCH	TUBO FLEXIBLE
2	07720400	TUBO FLESSIBILE MK2 (FROM C170000893)	FLEXIBLE PIPE MK2 (FROM C170000893)	TUYAU FLEXIBLE MK2 (FROM C170000893)	SCHLAUCH MK2 (FROM C170000893)	TUBO FLEXIBLE MK2 (FROM C170000893)
2	07721400	TUBO FLESSIBILE MK2 (FROM C170000893)	FLEXIBLE PIPE MK2 (FROM C170000893)	TUYAU FLEXIBLE MK2 (FROM C170000893)	SCHLAUCH MK2 (FROM C170000893)	TUBO FLEXIBLE MK2 (FROM C170000893)
3	27069300	CILINDRO LIVELLAMENTO CESTO	LEVELLING CYLINDER	CYLINDRE SECT.TÉLESCOP.	TELESKOPZYLINDER	CIL. BRAZO TELESCÓP.
3	270693A3	CILINDRO SFILO	EXTENSION CYLINDER	CYLINDRE SECT.TÉLESCOP.	TELESKOPZYLINDER	CIL. BRAZO TELESCÓP.
3	270693H2	CILINDRO LIVELLAMENTO CESTO	BASKET LEVELLING CYLINDER	CYLINDRE NIVELLEMENT PANIER	ZYLINDER KORBNIVELLIERUNG	CILINDRO NIVELACIÓN CESTA
4	07303600	TUBO FLESSIBILE	FLEXIBLE PIPE	TUYAU FLEXIBLE	SCHLAUCH	TUBO FLEXIBLE
5	07304500	TUBO FLESSIBILE	FLEXIBLE PIPE	TUYAU FLEXIBLE	SCHLAUCH	TUBO FLEXIBLE
6	07266600	TUBO RIGIDO	RIGID PIPE	TUYAU RIGIDE	ROHR	TUBO RÍGIDO
6	07877700	TUBO RIGIDO	RIGID PIPE	TUYAU RIGIDE	ROHR	TUBO RÍGIDO
7	07304400	TUBO FLESSIBILE	FLEXIBLE PIPE	TUYAU FLEXIBLE	SCHLAUCH	TUBO FLEXIBLE
8	27315100	CILINDRO LIVELLAMENTO CESTO SU CESTO	LEVELING CYLINDER BASKET ON BASKET	CYLINDRE SUR LEVEL BASKET BASKET	NIVELLIERZYLINDER	CILINDRO DE NIVEL DE BASKET BASKET
8	273151A3	CILINDRO LIVELLAMENTO CESTO SU CESTO	CYLINDER LEVEL BASKET ON BASKET	CYLINDRE SUR LEVEL BASKET BASKET	ZYLINDER AUF LEVEL WARENKORB WARENKORB	CILINDRO DE NIVEL DE BASKET BASKET



Main color codes:  J1 - JLG Cream,  J2 - JLG Orange,  C4 - Green

 IMPIANTO IDRAULICO LIVELLAMENTO
 LEVELING CYLINDERS HYDRAULIC SYSTEM
 SYSTÈME HYDRAULIQUE CYLINDRES BRAS



HYDRAULIKANLAGE ZYLINDER ARM 
 INSTALACIÓN HIDRÁULICA CILINDROS BRAZOS 

POS	Codice	 Descrizione	 Description	 Designation	 Benennung	 Descripción
8	273151H2	CILINDRO LIVELLAMENTO CESTO SU CESTO	LEVELING CYLINDER BASKET ON BASKET	CYLINDRE NIVELLEMENT PANIER SUR PANIER	ZYLINDER KORBNIVELLIERUNG	CILINDRO NIVELACIÓN CESTA

 IMPIANTO IDRAULICO ROTAZIONE CESTO
 CAGE ROTATION HYDRAULIC SYSTEM
 SYSTÈME HYDRAULIQUE ROTATION PANIER

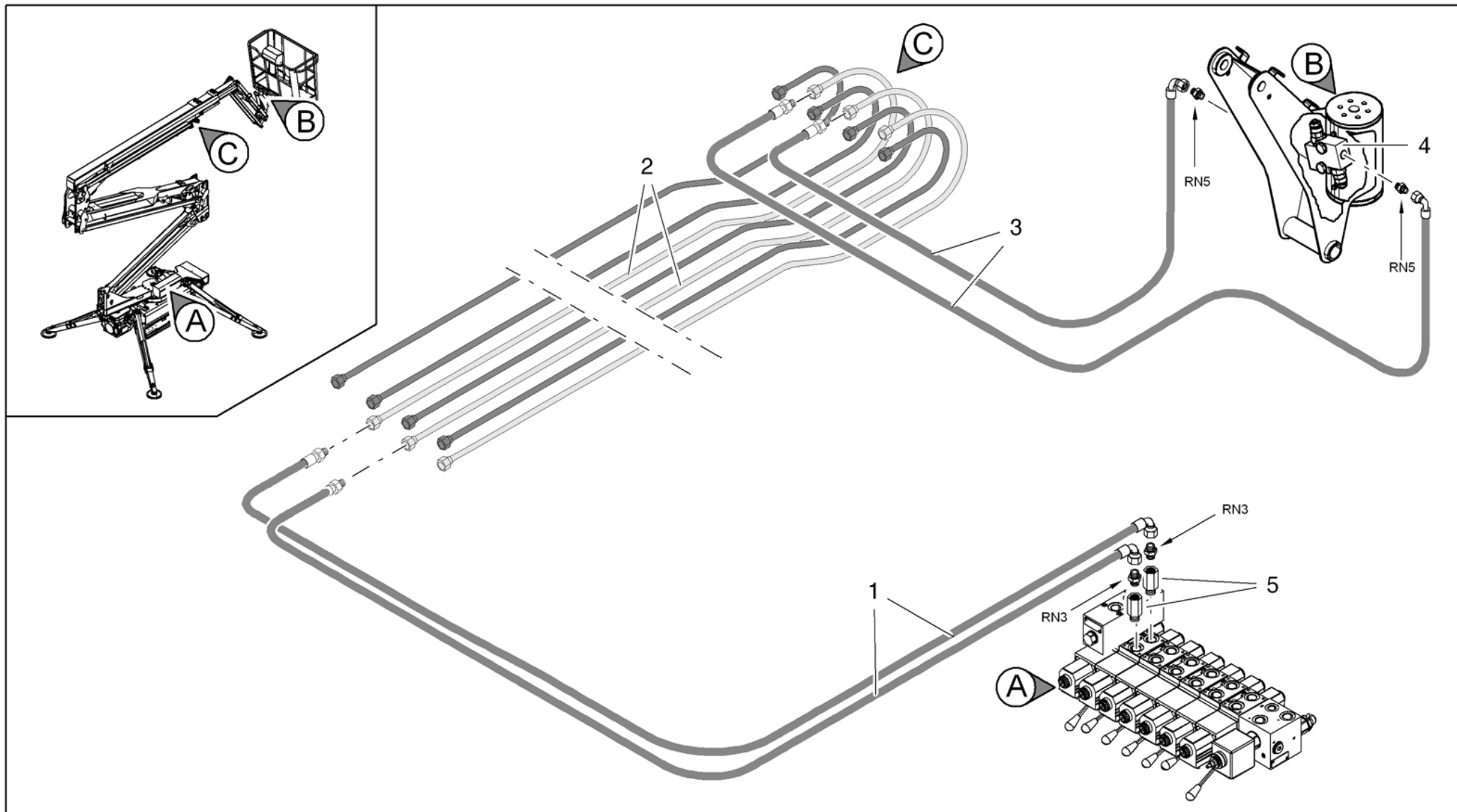
HYDRAULIKANLAGE KORBSCHWENKUNG 
 INSTALACIÓN HIDRÁULICA ROTACIÓN CESTA 









Main color codes:  J1 - JLG Cream,  J2 - JLG Orange,  C4 - Green



 IMPIANTO IDRAULICO ROTAZIONE CESTO



 CAGE ROTATION HYDRAULIC SYSTEM



 SYSTÈME HYDRAULIQUE ROTATION PANIER

 HYDRAULIKANLAGE KORBSCHWENKUNG 
 INSTALACIÓN HIDRÁULICA ROTACIÓN CESTA 



POS	Codice	 Descrizione	 Description	 Designation	 Benennung	 Descripción
1	07303800	TUBO FLESSIBILE	FLEXIBLE PIPE	TUYAU FLEXIBLE	SCHLAUCH	TUBO FLEXIBLE
1	07720800	TUBO FLESSIBILE MK2 (FROM C170000893)	FLEXIBLE PIPE MK2 (FROM C170000893)	TUYAU FLEXIBLE MK2 (FROM C170000893)	SCHLAUCH MK2 (FROM C170000893)	TUBO FLEXIBLE MK2 (FROM C170000893)
1	07720900	TUBO FLESSIBILE MK2 (FROM C170000893)	FLEXIBLE PIPE MK2 (FROM C170000893)	TUYAU FLEXIBLE MK2 (FROM C170000893)	SCHLAUCH MK2 (FROM C170000893)	TUBO FLEXIBLE MK2 (FROM C170000893)
1	07721800	TUBO FLESSIBILE MK2 (FROM C170000893)	FLEXIBLE PIPE MK2 (FROM C170000893)	TUYAU FLEXIBLE MK2 (FROM C170000893)	SCHLAUCH MK2 (FROM C170000893)	TUBO FLEXIBLE MK2 (FROM C170000893)
1	07721900	TUBO FLESSIBILE MK2 (FROM C170000893)	FLEXIBLE PIPE MK2 (FROM C170000893)	TUYAU FLEXIBLE MK2 (FROM C170000893)	SCHLAUCH MK2 (FROM C170000893)	TUBO FLEXIBLE MK2 (FROM C170000893)
2	07266800	TUBO RIGIDO	RIGID PIPE	TUYAU RIGIDE	ROHR	TUBO RÍGIDO
2	07877500	TUBO RIGIDO	RIGID PIPE	TUYAU RIGIDE	ROHR	TUBO RÍGIDO
3	07304600	TUBO FLESSIBILE	FLEXIBLE PIPE	TUYAU FLEXIBLE	SCHLAUCH	TUBO FLEXIBLE
4	2648910001	VALVOLA IDRAULICA	HYDRAULIC VALVE	VALVE HYDRAULIQUE	HYDRAULIKVENTIL	VÁLVULA HIDRÁULICA
5	03149500	RACCORDO A COLONNA 3/8" H=20	EXTENSION 3/8" H=20	RACCORD	ANSCHLUSS	CONEXIÓN



 Main color codes:  J1 - JLG Cream,  J2 - JLG Orange,  C4 - Green

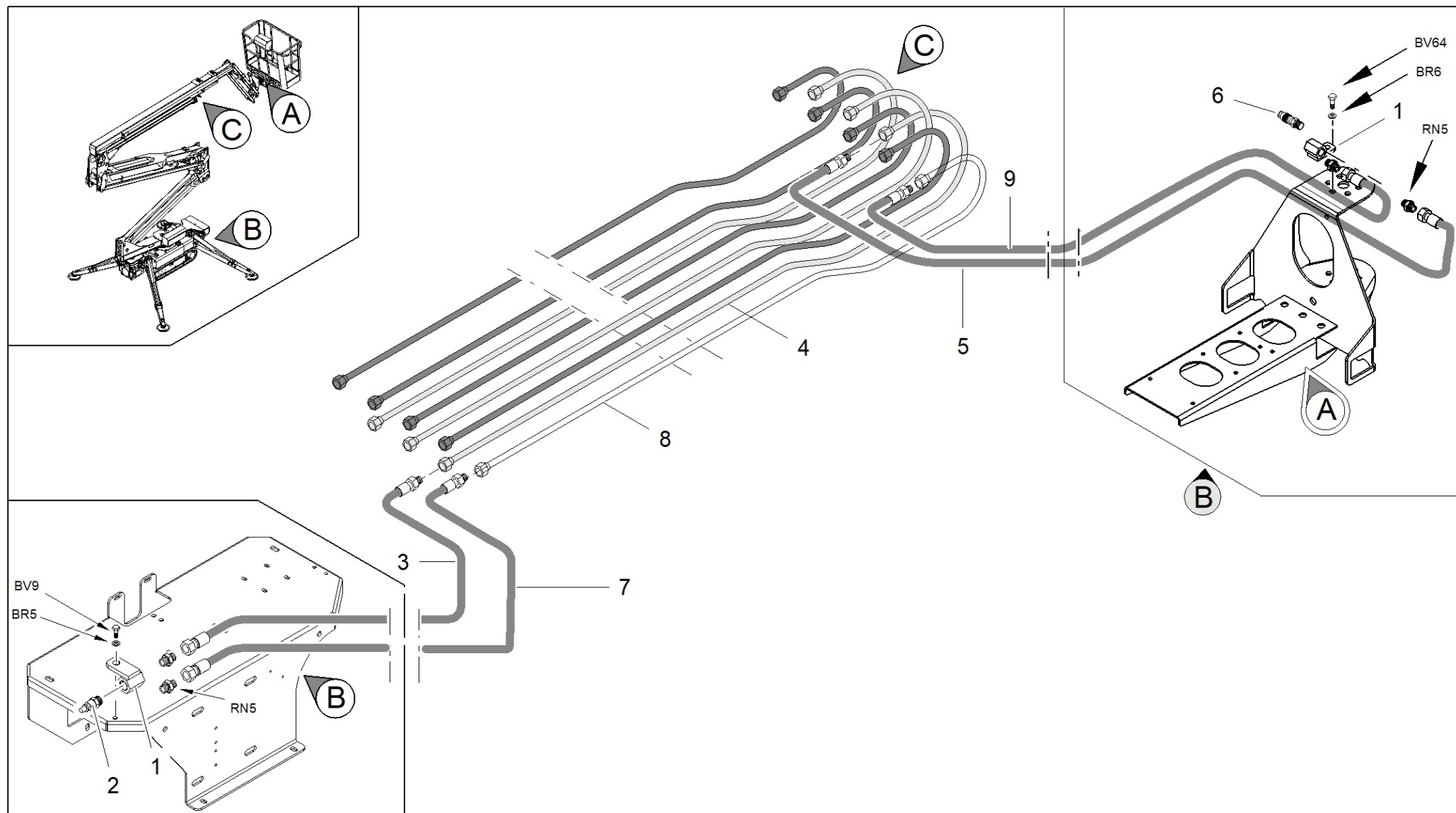

 IMPIANTO IDRAULICO ARIA COMPRESSA
 COMPRESSED AIR HYDRAULIC SYSTEM
 SYSTÈME HYDRAULIQUE AIR COMPRIMÉ





HYDRAULIKANLAGE DRUCKLUFT 
 INSTALACIÓN HIDRÁULICA AIRE COMPRIMIDO 





Main color codes:  J1 - JLG Cream,  J2 - JLG Orange,  C4 - Green



 IMPIANTO IDRAULICO ARIA COMPRESSA
 COMPRESSED AIR HYDRAULIC SYSTEM
 SYSTÈME HYDRAULIQUE AIR COMPRIMÉ

HYDRAULIKANLAGE DRUCKLUFT 
 INSTALACIÓN HIDRÁULICA AIRE COMPRIMIDO 

POS	Codice	 Descrizione	 Description	 Designation	 Benennung	 Descripción
1	04845100	SUPPORTO	SUPPORT	SUPPORT	HALTERUNG	SOPORTE
1	07611000	RACCORDO	PIPE FITTING	TUYAU	ANSCHLUSS	MANGUITO
1	07611100	RACCORDO	HOSE FITTING	TUYAU	ANSCHLUSS	CONEXIÓN
2	05509900	INNESTO RAPIDO	QUICK COUPLING	RACCORD RAPIDE	SCHNELLKUPPLUNG	CONEXIÓN RÁPIDA
3	07303900	TUBO FLESSIBILE	FLEXIBLE PIPE	TUYAU FLEXIBLE	SCHLAUCH	TUBO FLEXIBLE
3	07721000	TUBO FLESSIBILE MK2 (FROM C170000893)	FLEXIBLE PIPE MK2 (FROM C170000893)	TUYAU FLEXIBLE MK2 (FROM C170000893)	SCHLAUCH MK2 (FROM C170000893)	TUBO FLEXIBLE MK2 (FROM C170000893)
3	07722000	TUBO FLESSIBILE MK2 (FROM C170000893)	FLEXIBLE PIPE MK2 (FROM C170000893)	TUYAU FLEXIBLE MK2 (FROM C170000893)	SCHLAUCH MK2 (FROM C170000893)	TUBO FLEXIBLE MK2 (FROM C170000893)
4	07266900	TUBO RIGIDO	RIGID PIPE	TUYAU RIGIDE	ROHR	TUBO RÍGIDO
4	07877600	TUBO RIGIDO	RIGID PIPE	TUYAU RIGIDE	ROHR	TUBO RÍGIDO
5	07304700	TUBO FLESSIBILE	FLEXIBLE PIPE	TUYAU FLEXIBLE	SCHLAUCH	TUBO FLEXIBLE
6	05580200	RUBINETTO	FAUCET	ROBINET	WASSERHAHN	GRIFO
7	07915400	TUBO FLESSIBILE MK2 (FROM C170000893)	FLEXIBLE PIPE MK2 (FROM C170000893)	TUYAU FLEXIBLE MK2 (FROM C170000893)	SCHLAUCH MK2 (FROM C170000893)	TUBO FLEXIBLE MK2 (FROM C170000893)
7	07915500	TUBO FLESSIBILE MK2 (FROM C170000893)	FLEXIBLE PIPE MK2 (FROM C170000893)	TUYAU FLEXIBLE MK2 (FROM C170000893)	SCHLAUCH MK2 (FROM C170000893)	TUBO FLEXIBLE MK2 (FROM C170000893)
8	07877300	TUBO RIGIDO	RIGID PIPE	TUYAU RIGIDE	ROHR	TUBO RÍGIDO
8	07877400	TUBO RIGIDO	RIGID PIPE	TUYAU RIGIDE	ROHR	TUBO RÍGIDO
9	07915600	TUBO FLESSIBILE MK2 (FROM C170000893)	FLEXIBLE PIPE MK2 (FROM C170000893)	TUYAU FLEXIBLE MK2 (FROM C170000893)	SCHLAUCH MK2 (FROM C170000893)	TUBO FLEXIBLE MK2 (FROM C170000893)

Main color codes:  J1 - JLG Cream,  J2 - JLG Orange,  C4 - Green

 CILINDRI
 CYLINDERS
 CYLINDRES

ZYLINDER 
 CILINDROS 

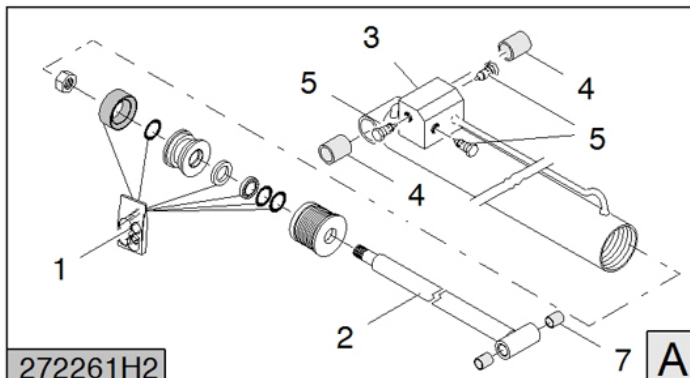

272261H2

A

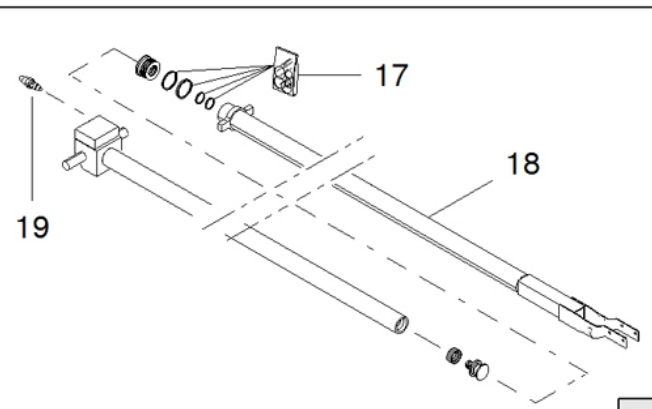

272262H2

D

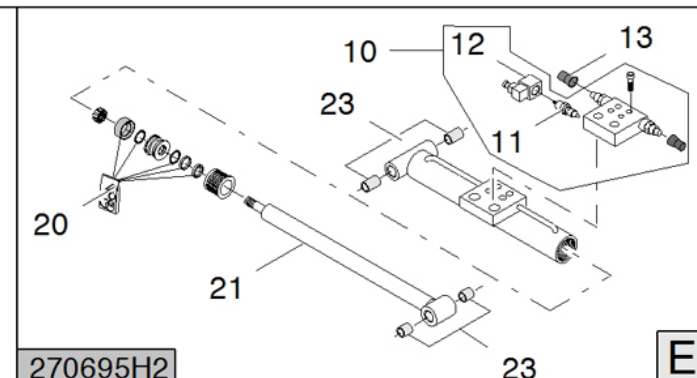

270695H2

E

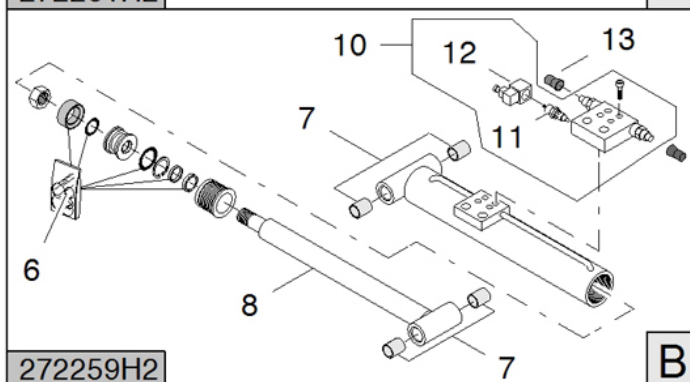

272259H2

B

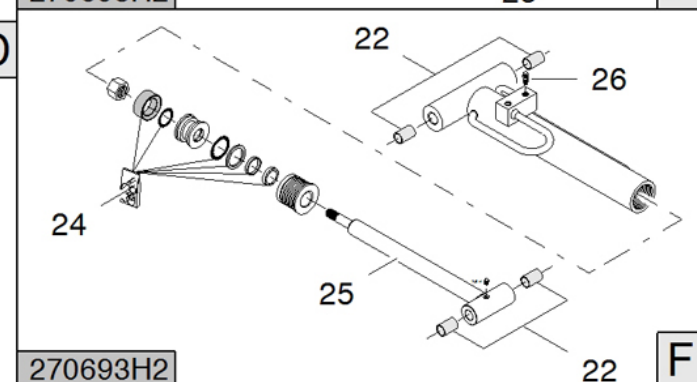
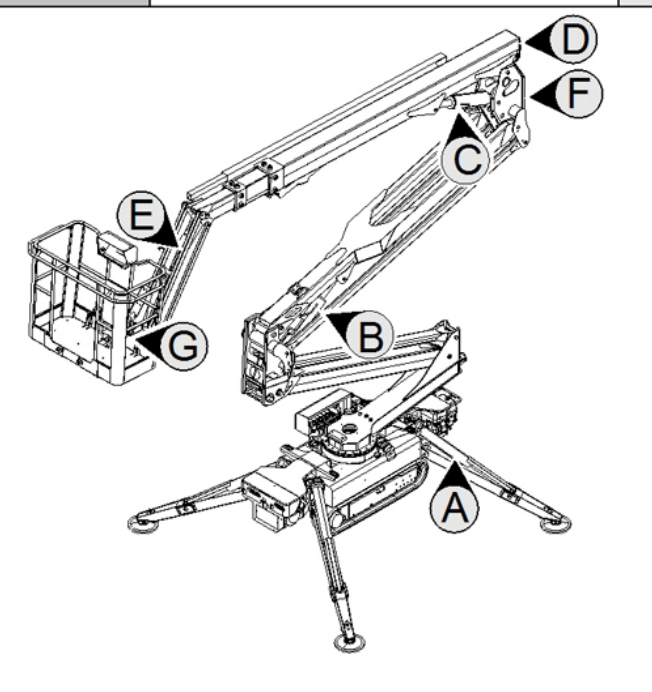

270693H2

F

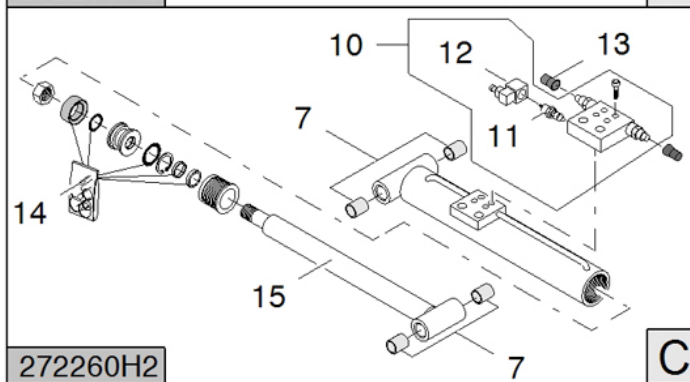

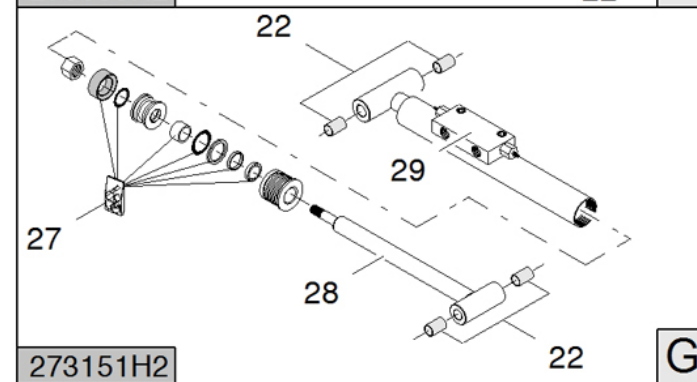

272260H2

C







273151H2



G

Main color codes:  J1 - JLG Cream,  J2 - JLG Orange,  C4 - Green

 CILINDRI
 CYLINDERS
 CYLINDRES



ZYLINDER 
 CILINDROS 



POS	Codice	 Descrizione	 Description	 Designation	 Benennung	 Descripción
1	2722610001	KIT GUARNIZIONI	GASKET KIT	KIT JOINTS	DICHTUNGSSATZ	KIT GUARNICIÓNES
2	2722610002	STELO	ROD	TIGE	SCHAFT	VÁSTAGO
3	2705540002	BLOCCETTO	BLOCK	BLOC	BLOCK	BLOQUE
4	2627880005	BOCCOLA	BUSH	DOUILLE	BUCHSE	CASQUILLO
5	1541150011	VALVOLA IDRAULICA	HYDRAULIC VALVE	VALVE HYDRAULIQUE	HYDRAULIKVENTIL	VÁLVULA HIDRÁULICA
6	2722590001	KIT GUARNIZIONI	GASKET KIT	KIT JOINTS	DICHTUNGSSATZ	KIT GUARNICIÓNES
7	2644250003	BOCCOLA	BUSH	DOUILLE	BUCHSE	CASQUILLO
8	2722590002	STELO	ROD	TIGE	SCHAFT	VÁSTAGO
10	08402000	VALVOLA IDRAULICA	HYDRAULIC VALVE	VALVE HYDRAULIQUE	HYDRAULIKVENTIL	VÁLVULA HIDRÁULICA
10	26119300	VALVOLA IDRAULICA	HYDRAULIC VALVE	VALVE HYDRAULIQUE	HYDRAULIKVENTIL	VÁLVULA HIDRÁULICA
11	0552550001	ELETTROVALVOLA	SOLENOID VALVE	ÉLECTROVANNE	MAGNETVENTIL	ELECTROVÁLVULA
12	0552550003	BOBINA	COIL	BOBINE	SPULE	BOBINA
12	0840200001	BOBINA	COIL	BOBINE	SPULE	BOBINA
13	05576200	PROTEZIONE	PROTECTION	PROTECTION	SCHUTZ	PROTECCIÓN
14	2722600001	KIT GUARNIZIONI	GASKET KIT	KIT JOINTS	DICHTUNGSSATZ	KIT GUARNICIÓNES
15	2722600002	STELO	ROD	TIGE	SCHAFT	VÁSTAGO
15	2722600003	SENSORE LINEARE CON LETTURA 355MM	SENSOR LINEAR WITH RANGE 355MM	CAPTEUR	SENSOR	SENSOR
17	2722620001	KIT GUARNIZIONI	GASKET KIT	KIT JOINTS	DICHTUNGSSATZ	KIT GUARNICIÓNES
18	2722620002	STELO	ROD	TIGE	SCHAFT	VÁSTAGO
19	2706900003	BLOCCO VALVOLA RIGENERATRICE CILINDRO SFILO	CYLINDER VALVE EXTENSION REGENERATIVE	SERRURE A CYLINDRE REGENERATIVE EXTENSION VALVE	SCHLIESSZYLINDER VALVE EXTENSION REGENERATIVE	QUEO DEL CILINDRO DE EXTENSIÓN DE LA VÁLVULA REGENERATIVA
20	2706950001	KIT GUARNIZIONI CILINDRO JIB	SEAL KIT CYLINDER JIB	KIT DE JOINTS	DICHTUNGSSATZ	KIT JUNTAS CILINDRO JIB
21	2706950002	STELO CILINDRO JIB	ROD CYLINDER JIB	TIGE DE CYLINDRE JIB	KORBARM ZYLINDERSCHAFT	VASTAGO CILINDRO JIB
22	2627890006	BOCCOLA	BUSH	DOUILLE	BUCHSE	CASQUILLO
23	2627910006	BOCCOLA	BUSH	DOUILLE	BUCHSE	CASQUILLO

Main color codes:  J1 - JLG Cream,  J2 - JLG Orange,  C4 - Green

 CILINDRI
 CYLINDERS
 CYLINDRES



ZYLINDER 
 CILINDROS 

POS	Codice	 Descrizione	 Description	 Designation	 Benennung	 Descripción
24	2706930001	KIT GUARNIZIONI CILINDRO LIVELLAMENTO SU RINVIO	CYLINDER GASKET KIT	KIT DE JOINTS CYLINDRE NIVELLEMENT	DICHTSATZ ZYLINDER AUSNIVELLIERUNG	KIT DE JUNTAS CILINDRO NIVELACIÓN
25	2706930002	STELO CILINDRO LIVELLAMENTO SU RINVIO	ROD CYLINDER	TIGE CYLINDRE	ZYLINDERSCHAFT	VASTAGO CILINDRO
26	2588290008	VITE	SCREW	VIS	SCHRAUBE	TORNILLO
27	2706940001	KIT GUARNIZIONI CILINDRO LIVELLAMENTO SU CESTO	CYLINDER GASKET KIT	KIT DE JOINTS CYLINDRE NIVELLEMENT	DICHTSATZ	KIT JUNTAS
28	2706940002	STELO CILINDRO LIVELLAMENTO SU CESTO	BASKET LEVELING CYLINDER ROD ON BASKET	CYLINDRE TIGE	ZYLINDERSCHAFT	VASTAGO CILINDRO
29	2731510003	VALVOLA IDRAULICA	HYDRAULIC VALVE	VALVE HYDRAULIQUE	HYDRAULIKVENTIL	VÁLVULA HIDRÁULICA

 COMPONENTI IMPIANTO ELETTRICO
 ELECTRICAL SYSTEM COMPONENTS
 COMPOSANTS INSTALLATION ÉLECTRIQUE

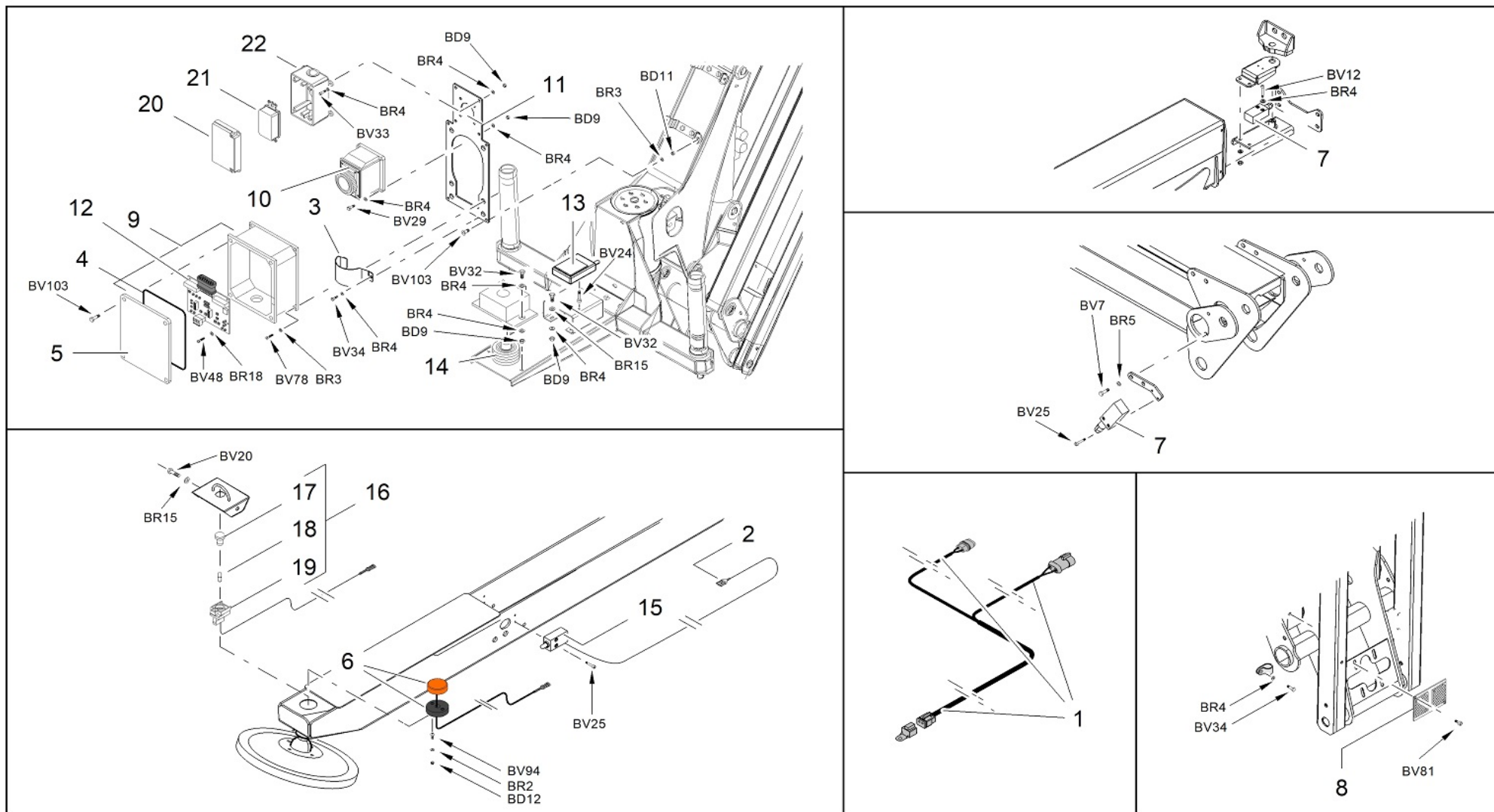
KOMponenten Elektroanlage 
 Componentes Instalación Eléctrica 









Main color codes:  J1 - JLG Cream,  J2 - JLG Orange,  C4 - Green



 COMPONENTI IMPIANTO ELETTRICO

 ELECTRICAL SYSTEM COMPONENTS

 COMPOSANTS INSTALLATION ÉLECTRIQUE

 KOMponenten Elektroanlage 
 Componentes Instalación Eléctrica 



POS	Codice	 Descrizione	 Description	 Designation	 Benennung	 Descripción
1	17727200	PROLUNGA PER LAMPEGGIANTE	CABLE EXTENSION FOR BEACON	RALLONGE	VERLÄNGERUNG	CABLE DE EXTENSIÓN
2	1730720085	CAVO STABILIZZATORE COMPLETO DI CONNETTORE E MICRO	STABILIZER CABLE WITH CONNECTOR AND MICRO	CONNECTEUR AVEC STABILISATEUR ET MICRO	KABELSTECKER MIT STABILISATOR UND MICRO	CABLE CONECTOR CON ESTABILIZADOR Y MICRO
2	1764250005	CAVO STABILIZZATORE COMPLETO DI CONNETTORE E MICRO PER LUCE A LED MK2 (DA C170000893)	STABILIZER CABLE WITH CONNECTOR AND MICRO FOR LED MK2 (FROM C170000893)	CONNECTEUR AVEC STABILISATEUR ET MICRO LED MK2 (FROM C170000893)	KABELSTECKER MIT STABILISATOR UND MICRO LED MK2 (FROM C170000893)	CABLE CONECTOR CON ESTABILIZADOR Y MICRO LED MK2 (FROM C170000893)
3	075163H3	PROTEZIONE CONNETTORI SCATOLA CELLA DICARICO MK2 (DA C170000893)	PROTECTION LOAD CELL CONNECTOR MK2 (FROM C170000893)	PROTECTION CONNECTEURS BOITE CELLULE DE CHARGE MK2 (FROM C170000893)	ABDECKUNG MK2 (FROM C170000893)	PROTECCION MK2 (FROM C170000893)
3	075914B8	PROTEZIONE CONNETTORI SCATOLA CELLA DICARICO AFTERMARKET	PROTECTION LOAD CELL CONNECTOR AFTER MARKET	PROTECTION CONNECTEURS BOITE CELLULE DE CHARGE	ABDECKUNG	PROTECCION
4	07141800	GUARNIZIONE SCATOLA CELLA DI CARICO IN ALLUMINIO	SEAL BOX ALUMINUM LOAD CELL	JOINT	DICHTUNG	SELLO
5	07141700	COPERCHIO SCATOLA CELLA DI CARICO IN ALLUMINIO	BOX COVER ALUMINUM LOAD CELL	COUVERCLE DE LA BOÎTE ALUMINIUM	SCHACHTELDECKEL ALUMINIUM	TAPA CAJA DE ALUMINIO





 Main color codes:  J1 - JLG Cream,  J2 - JLG Orange,  C4 - Green



 COMPONENTI IMPIANTO ELETTRICO

 ELECTRICAL SYSTEM COMPONENTS

 COMPOSANTS INSTALLATION ÉLECTRIQUE

 KOMponenten Elektroanlage 
 Componentes Instalación Eléctrica 



POS	Codice	 Descrizione	 Description	 Designation	 Benennung	 Descripción
6	1757250023	SPIA STABILIZZATORE LED COMPLETA DI CONNETTORE	LED LIGHT	TEMOIN LED	KONTROLLLAMPE	INDICADOR LED
7	1591270003	MICROINTERRUTTOR E 2 CONTATTI NC TESTINA ROTELLA ACCIAIO CAVO LUNGO 2 METRI	MICROSWITCH 2 NC CONTACTS HEAD STEEL WHEEL LONG CABLE 2M	MICROINTERRUPTEUR	MIKROSCHALTER	MICROINTERRUPTOR
8	1679890001	CATARIFRANGENTE 100X100 MM	REFLECTOR 100X100 MM	CATADIOPTRE	REFLEKTOR	CATADIÓPTRICO
9	1764250002	SCATOLA ALLUMINIO PER SCHEDA CELLA DI CARICO MV/V 2 CONNETTORI COMPLETA DI IMPIANTO, CONNETTORI E COPERCHIO (FINO A SC C170000893)	ALUMINUM BOX FOR LOAD CELL BOARD MV/V 2 CONNECTORS COMPLETE WITH SYSTEM, CONNECTORS AND COVER (UNTIL SN C170000893)	BOÎTE	GEHÄUSE	CAJA
9	17644500	SCATOLA ALLUMINIO PER SCHEDA CELLA DI CARICO IMPIANTI CON DOPPIO CONNETTORE PER SENSORE CELLA	BOX ALUMINUM SHEET LOAD CELL SYSTEMS WITH DUAL SENSOR CONNECTOR FOR CELL	BOÎTE ÉLECTRIQUE	ELEKTROGEHÄUSE	CAJA ELÉCTRICA
9	1779600003	SCATOLA CELLA DI CARICO 4-20MA COMPLETA DI CABLAGGIO INTERNO PER MK2 (NO TTC)	LOAD CELL BOARD 4- 20MA BOX WITH INTERNAL WIRING FOR MK2 (NO TTC)	BOÎTE CELLULE DE CHARGE	SCHALTKASTEN LASTÜBERWACHUNG SZELLE	CAJA CÉLULA DE CARGA
10	1585570005	PRESA ELETTRICA 230V	ELECTRICAL SOCKET 230V	PRISE ÉLECTRIQUE	STECKDOSE	ENCHUFE ELÉCTRICO





 Main color codes:  J1 - JLG Cream,  J2 - JLG Orange,  C4 - Green



 COMPONENTI IMPIANTO ELETTRICO

 ELECTRICAL SYSTEM COMPONENTS

 COMPOSANTS INSTALLATION ÉLECTRIQUE

 KOMONENTEN ELEKTROANLAGE 
 COMPONENTES INSTALACIÓN ELÉCTRICA 



POS	Codice	 Descrizione	 Description	 Designation	 Benennung	 Descripción
10	1591700002	PRESA ELETTRICA 110V	ELECTRICAL SOCKET 110V	PRISE ÉLECTRIQUE 110V	STECKDOSE 110V	ENCHUFE ELÉCTRICO 110V
11	07173300	PIASTRA VERSIONE CE	PLATE CE VERSION	PLATINE	PLATTE	PLACA
11	07173800	PIASTRA VERSIONE ANSI	PLATE ANSI VERSION	PLATINE	PLATTE	PLACA
11	076710H3	LAMIERA FISSAGGIO SCATOLA MK2 (DA C170000893)	PROTECTION MK2 (FROM C170000893)	PROTECTION MK2 (FROM C170000893)	SCHUTZ MK2 (FROM C170000893)	PROTECCION MK2 (FROM C170000893)
11	076860H3	LAMIERA FISSAGGIO SCATOLA MK2 (DA C170000893)	PLATE MK2 (FROM C170000893)	PLAQUE MK2 (FROM C170000893)	PLATTE MK2 (FROM C170000893)	PLACA MK2 (FROM C170000893)
12	1764250007	RELE'	RELE'	RELAIS	RELAIS	RELÉ
12	17770300	SCHEDA CELLA DI CARICO 4-20MA RESINATA (MK2)	ELECTRONIC BOARD LOAD SENSOR 4-20MA (MK2)	CARTE ÉLECTRONIQUE (MK2)	ELEKTRONISCHE PLATINE (MK2)	PLACA ELECTRÓNICA (MK2)
12	27480300	SCHEDA ELETTRONICA SENSORE DI CARICO (PERFORMANCE- PLUS-AUSTRALIA)	ELECTRONIC BOARD LOAD SENSOR (PERFORMANCE- PLUS-AUSTRALIA)	CARTE ÉLECTRONIQUE	ELEKTRONISCHE PLATINE	PLACA ELECTRÓNICA
13	27031700	INTERUTTORE A PEDALE	FOOT SWITCH	INTERRUPTEUR	FUßSCHALTER	INTERRUPTOR
14	1730720095	SENSORE CELLA DI CARICO COMPLETA DI CAVO E CONNETTORE CABLATO PERFORMANCE E PLUS(Until snC170000893 (with connector))	SENSOR LOAD CELL COMPLETE WIRED CABLE AND CONNECTOR FOR PERFORMANCE AND PLUS(Until snC170000893 (with connector))	CAPTEUR CELLULE DE CHARGE COMPLÈTE DE CÂBLE ET CONNECTEUR AVEC CÂBLAGE PERFORMANCE ET PLUS(Until snC170000893 (with connector))	KORBLASTSENSOR KOMPLETT MIT KABEL UND VERBINDER FÜR PERFORMANCE UND PLUS(Until snC170000893 (with connector))	SENSOR CÉLULA DE CARGA COMPLETA DE CABLE Y CONECTOR CABLEADO PERFORMANCE Y PLUS(Until snC170000893 (with connector))





 Main color codes:  J1 - JLG Cream,  J2 - JLG Orange,  C4 - Green



 COMPONENTI IMPIANTO ELETTRICO

 ELECTRICAL SYSTEM COMPONENTS





 COMPOSANTS INSTALLATION ÉLECTRIQUE



 KOMponenten Elektroanlage 
 Componentes Instalación Eléctrica 



POS	Codice	 Descrizione	 Description	 Designation	 Benennung	 Descripción
14	17669800	SENSORE CELLA DI CARICO 4-20MA COMPLETO DI CAVO E CONNETTORI M12 (MK2)	SENSOR LOAD CELL 4-20MA WITH CABLE AND CONNECTORS M12 (MK2 VERSION)	CELLULE DE CHARGE (MK2)	MESSDOSE (MK2)	CÉLULA DE CARGA (MK2)
14	17669800	SENSORE CELLA DI CARICO 4-20MA COMPLETO DI CAVO E CONNETTORI M12 (MK2)(Starting from MK2 sn C170000893)	SENSOR LOAD CELL 4-20MA WITH CABLE AND CONNECTORS M12 (MK2 VERSION) (Starting from MK2 sn C170000893)	CELLULE DE CHARGE (MK2)(Starting from MK2 sn C170000893)	MESSDOSE (MK2) (Starting from MK2 sn C170000893)	CÉLULA DE CARGA (MK2)(Starting from MK2 sn C170000893)
14	25611500	CELLA DI CARICO(Until snC170000893 (without connector))	LOAD CELL(Until snC170000893 (without connector))	CELLULE DE CHARGE(Until snC170000893 (without connector))	MESSDOSE(Until snC170000893 (without connector))	CÉLULA DE CARGA(Until snC170000893 (without connector))
15	1591270011	MICROINTERRUPTOR E 2 CONTATTI NC TESTINA A PULSANTE CAVO LUNGO 2 METRI	MICROSWITCH 2 NC CONTACTS BUTTON HEAD LONG CABLE 2M	MICROINTERRUPTEUR	MIKROSCHALTER	MICROINTERRUPTOR
16	1556350001	LUCE STABILIZZATORE	STABILIZER LIGHT	LUMIÈRE STABILISATEUR	ABSTÜTZUNGSBELEUCHTUNG	LUZ ESTABILIZADOR
17	1556350034	SPIA	PILOT LIGHT	TÉMOIN	KONTROLLLEUCHTE	INDICADOR LUMINOSO
18	1556350035	LAMPADINA	LAMP	AMPOULE	GLÜHBIRNE	BOMBILLA
19	1556350036	CORPO	BODY	CORPS	GEHÄUSE	CUERPO
20	27073800	COVER PRESE USA AL CESTO, RECEPTACLE BOX PART N°:1671207	COVER US SOCKETS TO BASKET, RECEPTACLE BOX PART N°:1671207	PRETECTION	SCHUTZ	PROTECCIÓN
21	27073900	PLUG PRESE USA AL CESTO, RECEPTACLE PART N°:4460346	US SOCKETS TO BASKET, RECEPTACLE PART N°:4460346	PRISE	STECKDOSE	ENCHUFE

 Main color codes:  J1 - JLG Cream,  J2 - JLG Orange,  C4 - Green

 COMPONENTI IMPIANTO ELETTRICO ELECTRICAL SYSTEM COMPONENTS COMPOSANTS INSTALLATION ÉLECTRIQUEKOMPONENTEN ELEKTROANLAGE COMPONENTES INSTALACIÓN ELÉCTRICA 



POS	Codice	 Descrizione	 Description	 Designation	 Benennung	 Descripción
22	27073700	BOX PRESE USA AL CESTO, RECEPTACLE PART N°:0861731	US SOCKET BOX TO BASKET, RECEPTACLE PART N°:0861731	BOX PRISES	SCHACHTEL STECKDOSEN	CAJA ENCHUFES

Main color codes:  J1 - JLG Cream,  J2 - JLG Orange,  C4 - Green

 COMPONENTI IMPIANTO ELETTRICO
 ELECTRICAL SYSTEM COMPONENTS
 COMPOSANTS INSTALLATION ÉLECTRIQUE

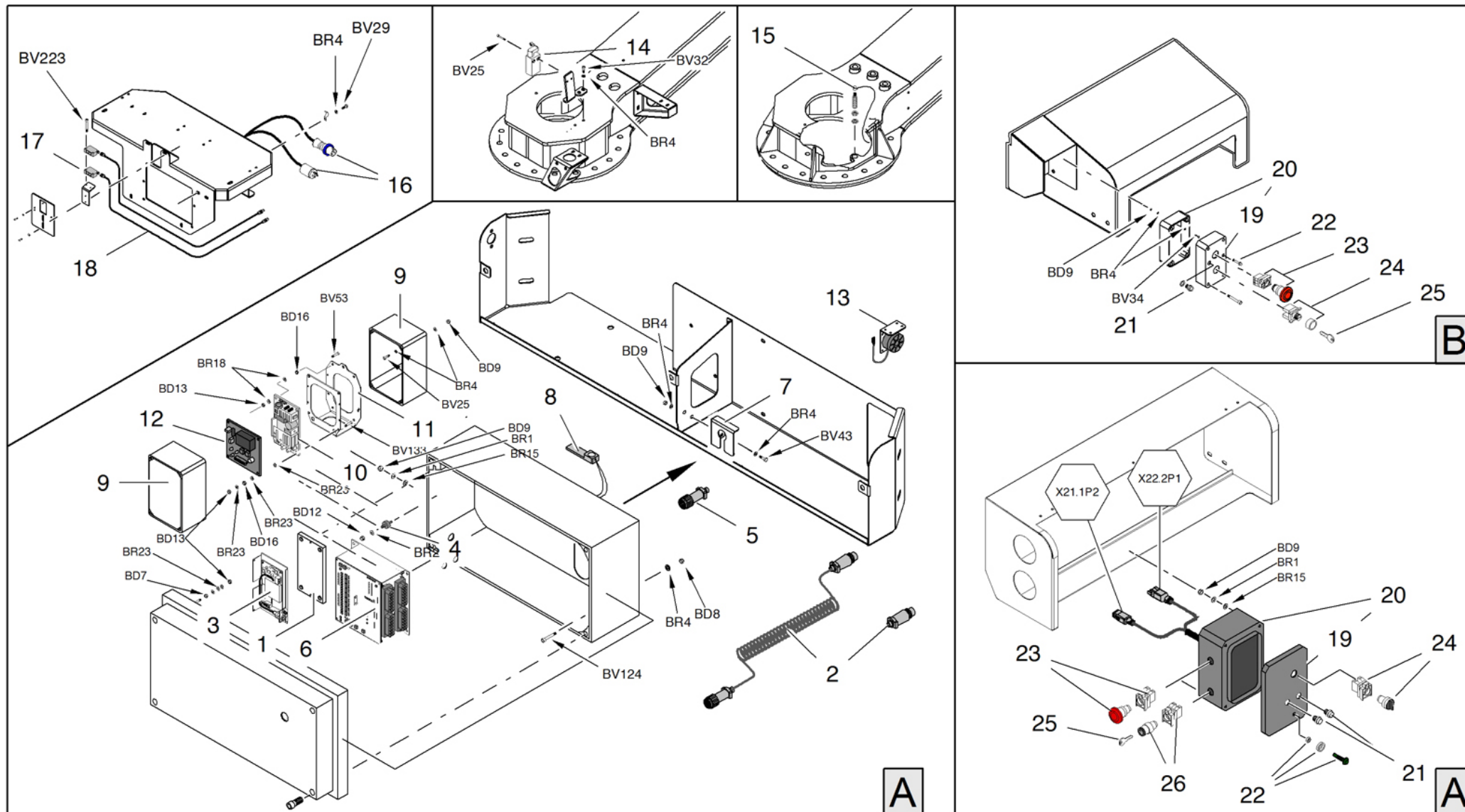
KOMPONENTEN ELEKTROANLAGE 
 COMPONENTES INSTALACIÓN ELÉCTRICA 









Main color codes:  J1 - JLG Cream,  J2 - JLG Orange,  C4 - Green



 COMPONENTI IMPIANTO ELETTRICO

 ELECTRICAL SYSTEM COMPONENTS

 COMPOSANTS INSTALLATION ÉLECTRIQUE

 KOMONENTEN ELEKTROANLAGE 
 COMPONENTES INSTALACIÓN ELÉCTRICA 



POS	Codice	 Descrizione	 Description	 Designation	 Benennung	 Descripción
1	07396000	PIASTRA ADATTAMENTO	PLATE ADAPTER	REGLAGE DE LA PLAQUE	FUSSPLATTENVERSTELLUNG	AJUSTE DE LA PLACA
2	07264200	CAVO SPIRALATO PER SERVICE/TELECOMANDO A TERRA	CABLE FOR SERVICE/REMOTE CONTROL GROUND	CÂBLE DE SERVICE / TELECOMMANDE A TERRE	KABEL FÜR SERVICE / FERNBEDIENUNG AM BODEN	CABLE PARA SERVICIO / CONTROL REMOTO A TIERRA
2	17264200	CAVO TELECOMANDO COMPLETO PER OPTIONAL	COMPLETE REMOTE CONTROL CABLE FOR OPTIONAL	CÂBLE TÉLÉCOMMANDE COMPLET	FERNBEDIENUNGSKABEL KOMPLETT	CABLE TELECOMANDO COMPLETO
2	2646170037	CONNETTORE PORTA MASCHI COLLEGAMENTO TELECOMANDO	CONNECTOR MALE PINS FOR REMOTE CONTROL	CONNECTEUR	VERBINGER	CONECTOR
3	27321800	SCHEDA MODEM CON NUOVO PROCESSORE (SUPPORTO A RICAMBIO 07396000) PER MACCHINE AUSTRALIA E PLUS	MODEM CARD WITH NEW CPU (MOUNTING SPARE PARTS 07396000) FOR AUSTRALIAN AND PLUS MACHINES	CARTE MODEM AVEC UN NOUVEAU PROCESSEUR	MODEMKARTE MIT NEUEN PROZESSOR	MODEM TARJETA CON NUEVO PROCESADOR
4	1730720018	ANTIVIBRANTE SCATOLA GENERALE SUPPORTO SCHEDA MASTER CIAM	ANTI-VIBRATING ELEMENT	INSERT EN CAOUTCHOUC	VIBRATIONSDÄMPFER	ANTIVIBRACION
5	17306800	CONNETTORE COMPLETO PER TELECOMANDO A TERRA E SERVICE	COMPLETE CONNECTOR FOR REMOTE CONTROL ON THE GROUND AND SERVICE	CONNECTEUR COMPLET	VERBINDER	CONECTOR
6	17162400	KIT RAMHINO	RAMHINO KIT	KIT RAMHINO	KIT RAMHINO	KIT RAMHINO
6	17162500	CAVO RAMHINO SCHALTBAU	CAVO RAMHINO SCHALTBAU	CÂBLE	KABEL	CABLE





 Main color codes:  J1 - JLG Cream,  J2 - JLG Orange,  C4 - Green

 COMPONENTI IMPIANTO ELETTRICO

 ELECTRICAL SYSTEM COMPONENTS

 COMPOSANTS INSTALLATION ÉLECTRIQUE



 KOMponenten Elektroanlage 
 Componentes Instalación Eléctrica 





POS	Codice	 Descrizione	 Description	 Designation	 Benennung	 Descripción
6	17506700	KIT BANCO PROGRAMMAZIONE SCHEDE PIATTAFORME	PROGRAMMATION KIT	KIT PROGRAMMATION	PROGRAMMATIONS A TZ	KIT PROGRAMACION
6	27179900	SCHEDA ELETTRONICA NUOVO PROCESSORE (PER MACCHINE AUSTRALIA E PLUS)	ELECTRONIC BOARD NEW CPU (FOR AUSTRALIAN AND PLUS MACHINES)	FICHE ÉLECTRONIQUE	ELEKTRONISCHE PLATINE	TARJETA ELECTRÓNICA
6	27180000	SCHEDA ELETTRICA NUOVO PROCESSORE VERSIONE LITIO	ELECTRIC BOARD NEW CHIP LITHIUM VERSION	FICHE ÉLECTRIQUE	ELEKTRISCHE PLATINE	TARJETA ELÉCTRICA
7	073181Y1	STAFFA	BRACKET	ÉTRIER	HALTEBÜGEL	ESTRIBO
8	27396100	ANTENNA	AERIAL	ANTENNE	ANTENNE	ANTENA
9	17348200	SCATOLA ELETTRICA SWITCHING (A PARTIRE DA C170000340 PER MACCHINE ANSI)	SWITCHING ELECTRICAL BOX (FROM C170000340 FOR ANSI MACHINES)	BOÎTE ÉLECTRIQUE	ELEKTROGEHÄUSE	CAJA ELÉCTRICA
10	27249800	ALIMENTATORE SWITCHING (DA C170000340 PER MACCHINE ANSI)	SWITCHING POWER SUPPLY (FROM C170000340 FOR ANSI MACHINES)	TRANSFORMATEUR	TRANSFORMATOR	TRANSFORMADOR
11	07243300	LAMIERA SUPPORTO SCHEDA E SWITCHING (DA C170000340 PER MACCHINE ANSI)	BRACKET FOR CARD AND SWITCHING (FROM C170000340 FOR ANSI MACHINES)	SUPPORT	HALTERUNG	SOPORTE
12	17722600	SCHEDA ELETTRONICA	ELECTRONIC BOARD	FICHE ÉLECTRIQUE	ELEKTRONISCHE PLATINE	PLACA ELECTRÓNICA
13	06639100	AVVISATORE ACUSTICO	ACOUSTIC ALARM	BUZZER	SUMMER	ZUMBADOR



 COMPONENTI IMPIANTO ELETTRICO

 ELECTRICAL SYSTEM COMPONENTS

 COMPOSANTS INSTALLATION ÉLECTRIQUE

 KOMONENTEN ELEKTROANLAGE 
 COMPONENTES INSTALACIÓN ELÉCTRICA 

POS	Codice	 Descrizione	 Description	 Designation	 Benennung	 Descripción
14	1590900003	MICROINTERRUTTOR E 2 CONTATTI NC TESTINA BRACCIO DISASSATO E ROTELLA IN PLASTICA CAVO LUNGO 2 METRI	2 NC CONTACTS MICROSWITCH HEAD OFFSET ARM AND WHEEL PLASTIC LONG CABLE 2M	MICROINTERRUPTEU R	MIKROSCHALTER	MICROINTERRUPTOR
15	1651290010	SENSORE DI PROSSIMITÀ	PROXIMITY SENSOR	CAPTEUR DE PROXIMITÉ	NÄHERUNGSSENSOR	SENSOR DE PROXIMIDAD
16	1556350013	SPINA FISSA 230V 90°	PLUG 230V 90 °	CHEVILLE	STIFT	CLAVIJA
16	1556350064	SPINA FISSA 110V 90°	PLUG	PRISE	STECKER	ENCHUFE
16	1757250001	SPINA VOLANTE 230V 16A	FREE PLUG 230V 16A	FICHE	STECKER	ENCHUFE
16	1757250002	SPINA VOLANTE 110V 32A	FREE PLUG 110V 32A	CHEVILLE	STIF	CLAVIJA
16	1757250003	SPINA VOLANTE 110V 16A	FREE PLUG 110V 16A	CHEVILLE	STIF	CLAVIJA
16	27074000	TERMINAL PRESA USA A TERRA, CONN PLUG PART N°:4460138	TERMINAL GROUND SOCKET USA, CONN PLUG PART N °: 4460138	CONNECTEUR	VERBINDER	CONECTOR
17	1591270001	FOTOCCELLULA	PHOTOCELL	CELLULE PHOTO- ÉLECTRIQUE	PHOTOZELLE	FOTOCÉLULA
18	159127000101	CAVO ELETTRICO	ELECTRIC CABLE	CÂBLE ÉLECTRIQUE	ELEKTROKABEL	CABLE ELÉCTRICO
19	175726002401	COPERCHIO SCATOLA STOP A TERRA DIESEL LL2614-X26JP- X770AJ	BOX COVER	COUVERCLE BOÎTE	KASTENABDECKUNG	TAPA DE CAJA
19	175727000201	COPERCHIO SCATOLA STOP A TERRA LITHIUM 83V	BOX COVER	COUVERCLE BOÎTE	KASTENABDECKUNG	TAPA DE CAJA





 Main color codes:  J1 - JLG Cream,  J2 - JLG Orange,  C4 - Green



 COMPONENTI IMPIANTO ELETTRICO

 ELECTRICAL SYSTEM COMPONENTS

 COMPOSANTS INSTALLATION ÉLECTRIQUE

 KOMponenten Elektroanlage 
 Componentes Instalación Eléctrica 

POS	Codice	 Descrizione	 Description	 Designation	 Benennung	 Descripción
20	1730720011	SCATOLA STOP A TERRA BENZINA/DIESEL COMPLETA DI CABLAGGIO E CONNETTORE	BOX GROUND STOP PETROL / DIESEL COMPLETE WIRING AND CONNECTOR	CONNECTEUR	VERBINDER	CONECTOR
20	173072001101	SCATOLA VUOTA STOP A TERRA BENZINA/DIESEL	BOX GROUND STOP PETROL / DIESEL	BOÎTE	GEHÄUSE	CAJA
20	1730720093	SCATOLA STOP A TERRA LITHIUM COMPLETA DI CABLAGGIO E CONNETTORE	BOX GROUND STOP LITHIUM COMPLETE WIRING AND CONNECTOR	BOITE	GEHÄUSE	CAJA
20	1757260024	SCATOLA STOP A TERRA DIESEL LL2614-X26JP-X770AJ COMPLETA DI CABLAGGIO E CONNETTORE	BOX WITH WIRING	BOÎTE AVEC CÂBLAGE	KASTEN MIT VERKABELUNG	CAJA CON CABLEADO
20	175726002402	SCATOLA STOP A TERRA MK2 E LL2614 VUOTA	STOP BOX MK2 AND LL2614 EMPTY	BOÎTE STOP	KASTEN STOP	CAJA STOP
20	1757270002	SCATOLA STOP A TERRA LITHIUM 83V COMPLETA DI CABLAGGIO E CONNETTORE	BOX WITH WIRING	BOÎTE AVEC CÂBLAGE	KASTEN MIT VERKABELUNG	CAJA CON CABLEADO
20	18096200	KIT ELETTRICO SPIA ROSSA LAMPEGGIANTE PER MACCHINE AUSTRALIA	ELECTRIC LIGHT BLINKING KIT FOR AUSTRALIA MACHINES	KIT ELECTRIQUE	ELEKTRISCHES KIT	KIT ELECTRICO
21	1628400005	PULSANTE	BUTTON	BOUTON	DRUCKKNOPF	BOTÓN

 Main color codes:  J1 - JLG Cream,  J2 - JLG Orange,  C4 - Green



 COMPONENTI IMPIANTO ELETTRICO



 ELECTRICAL SYSTEM COMPONENTS



 COMPOSANTS INSTALLATION ÉLECTRIQUE





 KOMponenten Elektroanlage 
 Componentes Instalación Eléctrica 



POS	Codice	 Descrizione	 Description	 Designation	 Benennung	 Descripción
22	1730720005	SPIA VERDE PARTE AEREA GRANDE	BIG GREEN LIGHT AERIAL PART	VOYANT	KONTROLLLEUCHTE	INDICADOR
23	1591270004	PULSANTE	BUTTON	BOUTON	DRUCKKNOPF	BOTÓN
24	1556350068	SELETTORE A LEVA 3 POSIZIONI	3 POSITION LEVER SWITCH	SÉLECTEUR	WÄHLSCHALTER	SELECTOR
25	1651290015	CHIAVE	KEY	CLÉ	SCHLÜSSEL	LLAVE
26	1692150001	BLOCCHETTO	BLOCK	BLOC	BLOCK	BLOQUE



 Main color codes:  J1 - JLG Cream,  J2 - JLG Orange,  C4 - Green



 IMPIANTO ELETTRICO
 ELECTRICAL SYSTEM
 INSTALLATION ÉLECTRIQUE





ELEKTRISCHE ANLAGE 
 INSTALACIÓN ELÉCTRICA 



POS	Codice	 Descrizione	 Description	 Designation	 Benennung	 Descripción
1	1730720009	SCATOLA GENERALE IMPIANTO ELETTRICO COMPLETA DI CABLAGGIO, CONNETTORI E COPERCHIO	MAIN BOX ELECTRICAL WIRING COMPLETE WITH CONNECTORS AND COVER	BOITE	GEHÄUSE	CAJA
1	1764250003	SCATOLA GENERALE IMPIANTO ELETTRICO COMPLETA DI CABLAGGIO, CONNETTORI E COPERCHIO MK2 (DA C170000893)	MAIN BOX ELECTRICAL WIRING COMPLETE WITH CONNECTORS AND COVER MK2 (FROM C170000893)	BOÎTE	GEHÄUSE	CAJA
2	1730720012	CONNETTORE PONTE VERSIONE BENZINA	CONNECTOR BRIDGE VERSION PETROL	CONNECTEUR	VERBINDER	CONECTOR
2	1730720013	CONNETTORE PONTE VERSIONE DIESEL 14RPM (LL2010)	CONNECTOR BRIDGE VERSION DIESEL 14RPM (LL2010)	CONNECTEUR	VERBINDER	CONECTOR
2	1730720073	TERMINALE MASCHIO D.0,5-1 MM (X34)	TERMINAL MALE D.0 0.5 TO 1 MM (X34)	BORNE MALE D.0 0,5 A 1 MM (X34)	TERMINAL MALE D.0 0,5 BIS 1 MM (X34)	TERMINAL MACHO D.0 0,5 A 1 MM (X34)
2	1730720074	TERMINALE MASCHIO D.1,5-2,5 MM (X34)	TERMINAL MALE D.1 0.5 TO 2, 5 MM (X34)	BORNE MALE D.1 0,5 A 2, 5 MM (X34)	TERMINAL MALE D.1 0,5 BIS 2, 5 MM (X34)	TERMINAL MACHO D.1 0,5 A 2, 5 MM (X34)
2	1730720075	TERMINALE FEMMINA D 0,5-1 MM (X34)	TERMINAL FEMALE D 0.5-1 MM (X34)	BORNE FEMELLE D 0,5-1 MM (X34)	TERMINAL FEMALE D 0,5-1 MM (X34)	TERMINAL HEMBRA D 0.5-1 MM (X34)
2	1730720076	TERMINALE FEMMINA D 1,5-2,5 MM (X34)	TERMINAL FEMALE D 1.5-2.5 MM (X34)	BORNE FEMELLE D 1,5-2,5 MM (X34)	TERMINAL FEMALE D 1,5-2,5 MM (X34)	TERMINAL HEMBRA D 1.5 A 2.5 MM (X34)
2	1730720090	CONNETTORE PONTE VERSIONE LITIO 72V	CONNECTOR BRIDGE VERSION LITHIUM 72V	CONNEXION PONT 72V VERSION DU LITHIUM	STECKVERBINDER BRÜCKE 72V LITHIUM VERSION	CONECTOR PUENTE VERSIÓN DE LITIO 72V



Main color codes:  J1 - JLG Cream,  J2 - JLG Orange,  C4 - Green



 IMPIANTO ELETTRICO
 ELECTRICAL SYSTEM
 INSTALLATION ÉLECTRIQUE





ELEKTRISCHE ANLAGE 
 INSTALACIÓN ELÉCTRICA 



POS	Codice	 Descrizione	 Description	 Designation	 Benennung	 Descripción
2	1776330001	CONNETTORE PONTE VERSIONE BENZINA MK2 (DA C170000893)	CONNECTOR BRIDGE VERSION PETROL MK2 (FROM C170000893)	CONNECTEUR	VERBINDER	CONECTADOR
3	1739150059	RELE' MICRO PER MONTAGGIO INTERNO SCATOLA 12V CON DIODO	MICRO RELAY 'FOR INTERNAL MOUNTING BOX WITH DIODE 12V	RELAIS MICRO POUR MONTAGE INTÉRIEUR BOÎTIER 12V AVEC DIODE	RELAIS MICROSCHALTER IM 12V KASTEN MIT DIODE	RELÉ MICRO PARA MONTAJE INTERNO CAJA 12V CON DIODO
4	1730720004	CENTRALINA 4 RELE' REGOLAZIONE RPM	RELAY BOX 4 'RPM ADJUSTMENT	BOÎTE RELAIS DE COMMANDE	RELAIS SCHACHTEL 4 RPM	CAJA RELÉ 4 RPM
5	17473800	PUNTALINO FEMMINA PER CONNETTORE 24 VIE SCHEDE CELLA DI CARICO D=2.8	FERRULE FEMALE CONNECTOR 24 WAY BOARD LOAD CELL D = 2.8	EMBOUT FEMELLE POUR CONNECTEUR 24 VOIES CARTE CELLULE DE CHARGE D=2.8	VERSCHRAUBUNG BUCHSE FÜR 24-WEGE-VERBINDER KORBLAST-PLATINE D=2,8	PUNTAL HEMBRA PARA CONECTOR 24 VÍAS CELULA DE CARGA D=2.8
6	05760800	FUSIBILE 7,5 A	FUSE 7,5 A	FUSIBLE 7,5 A	SICHERUNG 7,5 A	FUSIBLE 7,5 A
7	1730720010	COPERCHIO SCATOLA GENERALE IMPIANTO ELETTRICO	MAIN BOX ELECTRIC COVER	COUVERCLE	DECKEL	TAPA
8	17306000	PARTE DI CONNETTORE	CONNECTOR PART	CONNECTEUR	VERBINDER	CONECTADOR
9	17306100	COPERCHIO	COVER	COUVERCLE	DECKEL	TAPA
10	17306200	SLITTA	SLIDE	COULISSEAU	SCHLITTEN	CORREDERA
11	07503600	CONNETTORE PORTA FEMMINE 6 VIE PER MODEM	PORT CONNECTOR 6 WAY FEMALE FOR MODEM	CONNECTEUR PORTE-FEMELLES 6 VOIES POUR MODEM	VERBINDER	CONECTOR
12	1730720077	CONNETTORE 17 VIE M CENTRALINA RELE' RPM (X33)	CONNECTOR	CONNECTEUR	VERBINDER	CONECTADOR
13	17306300	PUNTALINO FEMMINA PER CONNETTORE 56 VIE SCHEDE MASTER D=1.5	FERRULE FEMALE CONNECTOR 56 WAY MAIN BOARD D = 1.5	BUTÉE FEMELLE CONNECTEUR 56 VOIES CARTE MASTER D = 1.5	AUFLAGESTIFT BUCHSE 56-WEGE-VERBINDER MASTERPLATINE D = 1.5	CONECTOR PUNTA HEMBRA 56 VÍAS TARJETA MASTER D=1,5



Main color codes:  J1 - JLG Cream,  J2 - JLG Orange,  C4 - Green

 IMPIANTO ELETTRICO
 ELECTRICAL SYSTEM
 INSTALLATION ÉLECTRIQUE



ELEKTRISCHE ANLAGE 
 INSTALACIÓN ELÉCTRICA 



POS	Codice	 Descrizione	 Description	 Designation	 Benennung	 Descripción
14	17473700	SLITTA PER CONNETTORE 24 VIE	SLIDE FOR 24-WAY CONNECTOR	COULISSEAU	SCHLITTEN	CORREDERA
15	17473600	PARTE DI CONNETTORE 24VIE	CONNECTOR PART 24 WAY	CONNECTEUR	VERBINGER	CONECTADOR
16	1730720078	CONTATTO FEMMINA (X33)	CONTACT FEMALE (X33)	CONTACT FEMELLE (X33)	CONTACT FEMALE (X33)	CONTACTO HEMBRA (X33)
17	1585570006	SELETORE	SELECTOR	SÉLECTEUR	WÄHLSCHALTER	SELECTOR
18	07503700	PUNTALINO FEMMINA PER CONNETTORE MODEM	CLAMP	BORNE	KLEMME	BORNE

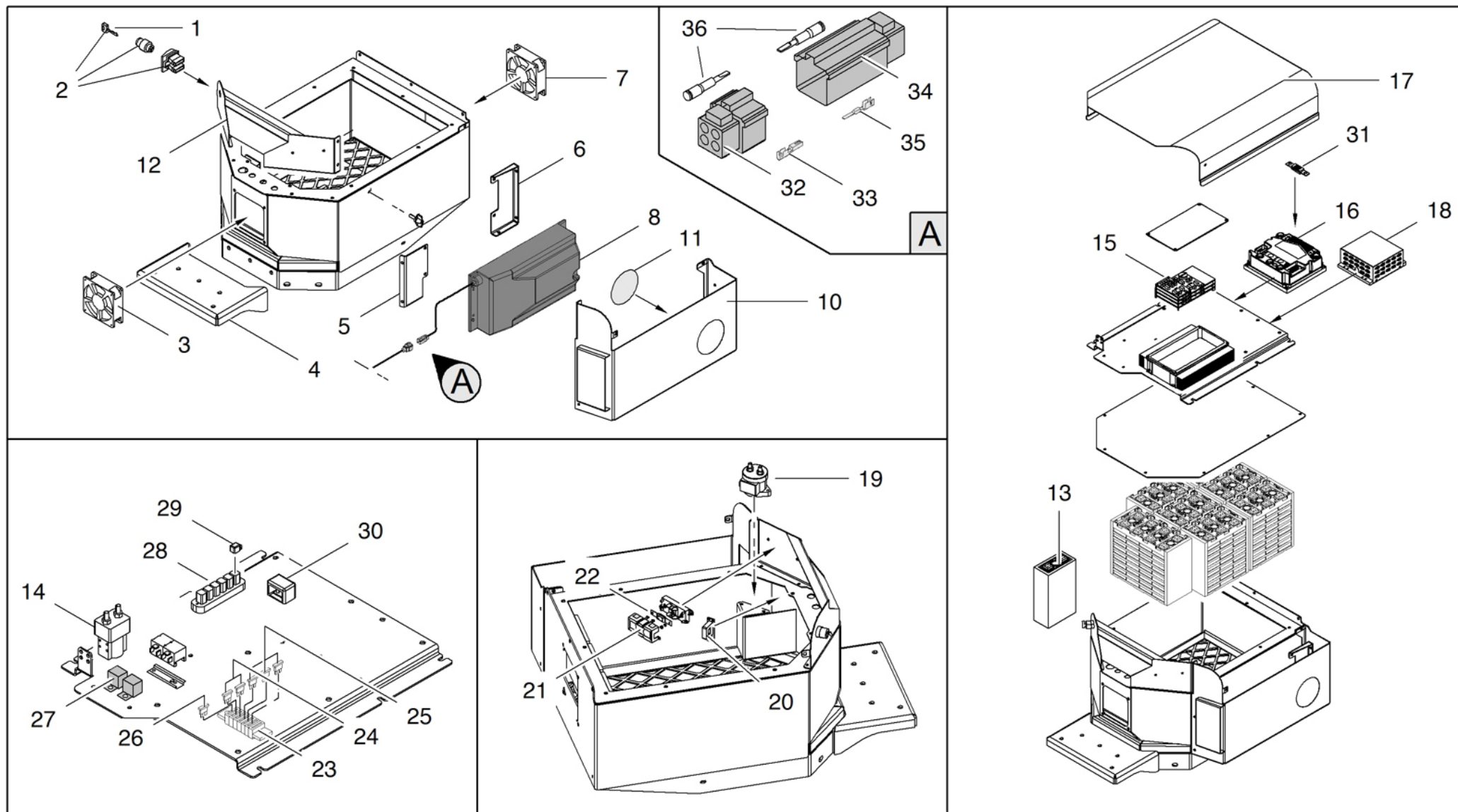

 COMPONENTI IMPIANTO ELETTRICO LITIO
 ELECTRICAL SYSTEM COMPONENTS LITHIUM
 COMPOSANTS INSTALLATION ÉLECTRIQUE LITHIUM





KOMponenten Elektroanlage Lithium 
 Componentes Instalación Eléctrica Lithium 







Main color codes:  J1 - JLG Cream,  J2 - JLG Orange,  C4 - Green





 COMPONENTI IMPIANTO ELETTRICO LITIO
 ELECTRICAL SYSTEM COMPONENTS LITHIUM
 COMPOSANTS INSTALLATION ÉLECTRIQUE LITHIUM



KOMPONENTEN ELEKTROANLAGE LITHIUM 
 COMPONENTES INSTALACIÓN ELÉCTRICA LITHIUM 



POS	Codice	 Descrizione	 Description	 Designation	 Benennung	 Descripción
2	1730720091	BLOCCHETTO CHIAVE COMPLETO DI CHIAVE PER PACCHI LITIO PERFORMANCE (PLUS)	KEY BLOCK COMPLETE WITH KEY FOR LITHIUM PERFORMANCE (PLUS)	BLOC CLÉ COMPLÈTE	KEY BLOCK COMPLETE	BLOQUE CLAVE COMPLETO
3	1690690001	VENTOLA ANTERIORE	FRONT FAN	VENTILATEUR	LÜFTERRAD	VENTILADOR
7	1690690002	VENTOLA POSTERIORE	REAR FAN	VENTILATEUR	LÜFTERRAD	VENTILADOR
8	16947800	CARICA BATTERIA LITIO 72V 230V	BATTERY CHARGER LITHIUM 72V 230V	CHARGE BATTERIE	BATTERIELADER	CARGA BATERÍAS
8	17085100	CARICA BATTERIA LITIO 72V 110/120V	BATTERY CHARGER LITHIUM 72V 110/120V	CHARGE BATTERIE	BATTERIELADER	CARGA BATERÍAS
8	17604200	CARICABATTERIE 80V-240V LITHIUM	LITHIUM BATTERY CHARGER 80V-240V	LITHIUM BATTERIE 80V-240V	BATTERIELADEGERÄ T 80V-240V LITHIUM	CARGADOR DE BATERÍA 80V-240V LITIO
8	27604200	CARICABATTERIE 80V-240V LITHIUM	LITHIUM BATTERY CHARGER 80V-240V	LITHIUM BATTERIE 80V-240V	BATTERIELADEGERÄ T 80V-240V LITHIUM	CARGADOR DE BATERÍA 80V-240V LITIO
10	37496300	SALDATO PROTEZIONE CARICABATTERIE LL2010, X20JP	WELDED PROTECTION FOR BATTERY CHARGER LL2010, X20JP, X600AJ	PROTECTION SAUDÉE CHARGEUR DE BATTERIE LL201, X20JP	SCHUTZ FÜR BATTERIELADEGERÄ T LL2010, X20JP, X600AJ	PROTECCIÓN CARGADOR DE BATERÍAS LL2010, X20JP
10	37634600	SALDATO PER CASSONE LITHIUM LL2010 X20JP	SUPPORT	SUPPORT	HALTERUNG	SOPORTE
11	07377300	PROTEZIONE TRASPARENTE LED CARICABATTERIE PACCO LITIO 72V	TRANSPARENT PROTECTION CHARGER LED	PROTECTION TRANSPARENT	TRANSPARENT SCHUTZART	PROTECCIÓN TRANSPARENTE



 COMPONENTI IMPIANTO ELETTRICO LITIO
 ELECTRICAL SYSTEM COMPONENTS LITHIUM
 COMPOSANTS INSTALLATION ÉLECTRIQUE LITHIUM

KOMPONENTEN ELEKTROANLAGE LITHIUM 
 COMPONENTES INSTALACIÓN ELÉCTRICA LITHIUM 



POS	Codice	 Descrizione	 Description	 Designation	 Benennung	 Descripción
12	37496200	SALDATO PROTEZIONE SUPERIORE CASSONE LITHIUM LL2010, X20JP	UPPER PROTECTION FOR LITHIUM BOX LL2010, X20JP, X600AJ	PROTECTION SUPÉRIEUR SAUDÉE CAISSON LITHIUM LL2010, X20JP	OBERSCHUTZ FÜR LITHIUM KASTEN LL2010, X20JP	PROTECCIÓN SUPERIOR CAJÓN LITHIUM LL2010, X20JP
13	1742410001	CELLA LITIO VERSIONE B	LITHIUM CELL VERSION B	CELLULE LITHIUM UNIQUE B	LITHIUM EINZELZELLE B	CELDA BATERIA LITIO VERSION B
14	26429300	TELERUTTORE	POWER SWITCH RELAY	TÉLÉRUPTEUR	FERNSCHALTER	TELERUPTOR
15	1737990001	BMS 72V NUOVA VERSIONE (DA C170000352)	BMS 72V NEW VERSION (FROM C170000352)	BMS 72V	BMS 72V	BMS 72V
15	1737990002	CONTATTI A CRIMPARE C PER BMS	FERRULE CRIMP C FOR BMS	FERRULE	NUTMUTTER	ANILLO
15	1737990003	CONTATTI A CRIMPARE F PER BMS	FERRULE CRIMP F FOR BMS	FERRULE	NUTMUTTER	ANILLO
15	1737990004	HOUSING F CAN 4VIE PER BMS	HOUSING F CAN 4 WAY FOR BMS	LOGEMENT	GEHÄUSE	ALOJAMIENTO
15	1737990005	HOUSING F OPTO POWER 8VIE PER BMS	HOUSING F OPTO POWER 8 WAY FOR BMS	LOGEMENT	GEHÄUSE	ALOJAMIENTO
15	1737990006	HOUSING F VOLTAGE 20VIE PER BMS	HOUSING F VOLTAGE 20 WAY FOR BMS	LOGEMENT	GEHÄUSE	ALOJAMIENTO
15	1737990007	HOUSING C NO OPTO SIGNAL 18VIE PER BMS	HOUSING C NO OPTO SIGNAL 18 WAY FOR BMS	LOGEMENT	GEHÄUSE	ALOJAMIENTO
15	1737990008	HOUSING C OPTO SIGNAL 14VIE FOR BMS	HOUSING C OPTO SIGNAL 14 WAY FOR BMS	LOGEMENT	GEHÄUSE	ALOJAMIENTO
15	1737990009	HOUSING C TEMPERATURE 16VIE FOR BMS	HOUSING C TEMPERATURE 16 WAY FOR BMS	LOGEMENT	GEHÄUSE	ALOJAMIENTO
16	1694760002	INVERTER	INVERTER	INVERTER	INVERTER	INVERTER
16	26947600	INVERTER	INVERTER	INVERTER	INVERTER	INVERTER



Main color codes:  J1 - JLG Cream,  J2 - JLG Orange,  C4 - Green

 COMPONENTI IMPIANTO ELETTRICO LITIO
 ELECTRICAL SYSTEM COMPONENTS LITHIUM
 COMPOSANTS INSTALLATION ÉLECTRIQUE LITHIUM





KOMPONENTEN ELEKTROANLAGE LITHIUM 
 COMPONENTES INSTALACIÓN ELÉCTRICA LITHIUM 



POS	Codice	 Descrizione	 Description	 Designation	 Benennung	 Descripció
17	07496100	COPERCHIO SUPERIORE PER CASSONE LITHIUM LL2010, X20JP	UPPER COVER FOR LITHIUM BOX LL2010, X20JP, X600AJ	COUVERCLE SUPÉRIEUR POUR CAISSON LITHIUM LL2010, X20JP, X600AJ	OBERDECKEL FÜR LITHIUM-BOX LL2010, X20JP, X600AJ	TAPA SUPERIOR PARA CAJÓN LITHIUM LL2010, X20JP
17	07634900	COPERCHIO	COVER	COUVERCLE	DECKEL	TAPA
18	26947900	TRASFORMATORE	TRANSFORMER	TRANSFORMATEUR	TRANSFORMATOR	TRANSFORMADOR
19	1690690020	TELERUTTORE	REMOTE-CONTROL SWITCH	TÉLÉRUPTEUR	FERNSCHALTER	TELERUPTOR
20	1735210002	TRASDUTTORE DI CORRENTE (DA C170000330)	CURRENT TRANSDUCER (FROM C170000330)	TRANSFORMATEUR D'INTENSITÉ (DA C170000330)	STROMMESSUMFORMER (DA C170000330)	TRANSDUCTOR DE CORRIENTE ELÉCTRICA (DA C170000330)
21	1690690009	COPERCHIO	COVER	COUVERCLE	DECKEL	TAPA
22	1690690011	FUSIBILE 160A	FUSE 160A	FUSIBLE 160A	SICHERUNG 160A	FUSIBLE 160A
23	1690690003	BLOCCHETTO	FUSE HOLDERS BLOCK	BLOC	BLOCK	BLOQUE
23	1735210003	PUNTALINO PER CAVO SINGOLO SU FUSIBILE PACCO LITIO	CONNECTOR FOR FUSE ON SINGLE WIRE BATTERY PACK	CAPTEUR LEM	SENSOR LEM	SENSOR LEM
23	1735210004	PUNTALINO PER CAVO DOPPIO SU FUSIBILE PACCO LITIO	CONNECTOR FOR FUSE ON DOUBLE WIRE BATTERY PACK	CAPTEUR LEM	SENSOR LEM	SENSOR LEM
24	05760600	FUSIBILE 3A	FUSE 3A	FUSIBLE 3A	SICHERUNG 3A	FUSIBLE 3A
25	05760900	FUSIBILE 10A	FUSE 10A	FUSIBLE 10A	SICHERUNG 10A	FUSIBLE 10A
26	05760800	FUSIBILE 7,5 A	FUSE 7,5 A	FUSIBLE 7,5 A	SICHERUNG 7,5 A	FUSIBLE 7,5 A
26	1757250012	TAPPO PER CHIUSURA FORI SU CONNETTORE 4 VIE MOLEX 220-110V 20-25A	CAP	BOUCHON	DECKEL	TAPA
27	1690690005	RELÈ	RELAY	RELAIS	RELAIS	RELÉ

Main color codes:  J1 - JLG Cream,  J2 - JLG Orange,  C4 - Green



 COMPONENTI IMPIANTO ELETTRICO LITIO
 ELECTRICAL SYSTEM COMPONENTS LITHIUM
 COMPOSANTS INSTALLATION ÉLECTRIQUE LITHIUM



KOMPONENTEN ELEKTROANLAGE LITHIUM 
 COMPONENTES INSTALACIÓN ELÉCTRICA LITHIUM 

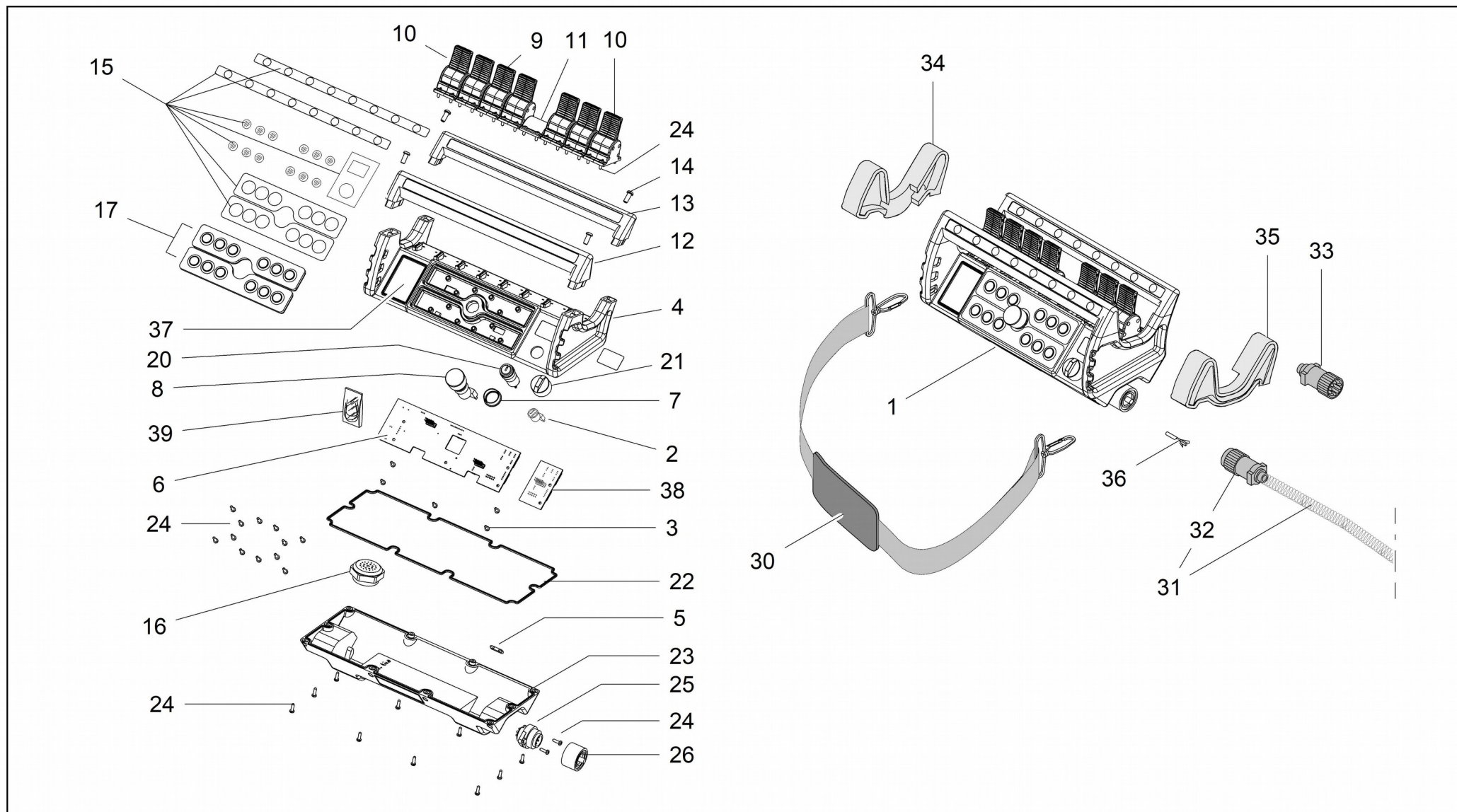



POS	Codice	 Descrizione	 Description	 Designation	 Benennung	 Descripción
28	1730720087	CONNETTORE DERIVAZIONE CAN	JUNCTION CONNECTOR CAN	CONNECTEUR	VERBINDER	CONECTOR
29	1730720086	TAPPO CONNETTORE 2 VIE	CONNECTOR PLUG 2 WAY	BOUCHON CONNECTEUR	VERSCHLUSS VERBINDER	TAPA CONECTOR
30	1730720088	ISOLATORE CONNESSIONE MASSA	INSULATOR EARTH CONNECTION	ISOLATEUR	ISOLATOR	AISLADOR
31	2694760001	FUSIBILE	FUSE	FUSIBLE	SICHERUNG	FUSIBLE
32	1757250009	CONNETTORE PORTA FEMMINE 4 VIE MOLEX 220-110V 20-25A	CONNECTOR	CONNECTEUR	VERBINDER	CONECTOR
33	1757250011	PUNTALINO	FERRULE	EMBOUT	ZWINGE	PUNTERA
34	1757250010	CONNETTORE PORTA MASCHI 4 VIE MOLEX 220-110V 20-25A	CONNECTOR	CONNECTEUR	VERBINDER	CONECTOR
35	1757250013	PUNTALINO MASCHIO PER CONNETTORE 4 VIE MOLEX 220-110V 20-25A	FERRULE	EMBOUT	ZWINGE	PUNTERA
36	1757250012	TAPPO PER CHIUSURA FORI SU CONNETTORE 4 VIE MOLEX 220-110V 20-25A	CAP	BOUCHON	DECKEL	TAPA
37	078574D1	CHIUSURA FORI FISSAGGIO PER LAMPEGGIANTE SU PACCO LITIO	CLOSING FIXING HOLES FOR FLASHING ON PACK LITHIUM	FERMETURE	SCHLUSS	CIERRE
38	1742420001	CABLAGGIO COMPLETO PACCO LITIO NUOVO BMS 72V (DA C170000352)	WIRING	CÂBLAGE	VERKABELUNG	CABLEADO



Main color codes:  J1 - JLG Cream,  J2 - JLG Orange,  C4 - Green







 TELECOMANDO
 REMOTE CONTROL
 TÉLÉCOMMANDE

FERNSTEUERUNG 
 TELECOMANDO 



POS	Codice	 Descrizione	 Description	 Designation	 Benennung	 Descripción
1	27237400	TELECOMANDO CASE GRIGIO	REMOTE CONTROL GREY CASE	TÉLÉCOMMANDE	FERNSTEUERUNG	TELECOMANDO
2	07359400	CONTATTO PER STOP EMERGENZA TELECOMANDO 3S	CONTACT FOR EMERGENCY STOP REMOTE CONTROL 3S	CONTACTE POUR ARRET D'URGENCE	KONTAKT FÜR NOTSTOP	CONTACTO PARA PARADA DE EMERGENCIA
3	2646170003	VITI SCHEDA ELETTRONICA	ELECTRONIC BOARD SCREWS	VIS	SCHRAUBEN	TORNILLOS
4	2723740001	COPERCHIO SUPERIORE TELECOMANDO CASE GRIGIO + DISPLAY E PULSANTI (PER RICAMBIO È NECESSARIO IL SN DEL TELECOMANDO)	TOP COVER REMOTE CONTROL CASE GREY + DISPLAY AND BUTTONS (AS SPARE IS COMPULSORY THE SN OF REMOTE CONTROL)	COUVERCLE	DECKEL	TAPA
4	2723740002	COPERCHIO SUPERIORE TELECOMANDO CASE GRIGIO SOLO COPERCHIO, SENZA COMPONENTI E SENZA DISPLAY	TOP COVER REMOTE CONTROL CASE GREY ONLY CASE, WITHOUT COMPONENTS AND DISPLAY	COUVERCLE	DECKEL	TAPA
5	07359500	CONTATTO REED INTERNO TELECOMANDO 3S	REED CONTACT INTERNAL REMOTE 3S	REED CONTACT INTÉRIEUR 3S DISTANCE	REEDKONTAKT INDOOR REMOTE 3S	CONTACTO REED 3S REMOTO DE INTERIOR
6	2646170002	SCHEDA ELETTRONICA PER TELECOMANDO	ELECTRONIC BOARD FOR REMOTE CONTROL	FICHE ÉLECTRIQUE	ELEKTRONISCHE PLATINE	PLACA ELECTRÓNICA
7	2646170007	ANELLO	RING	BAGUE	RING	ANILLO
8	2646170008	PULSANTE EMERGENZA	EMERGENCY BUTTON	BOUTON D'URGENCE	NOTSTOP KNOPF	PULSADOR DE EMERGENCIA
9	17550700	KIT PROTEZIONE IN GOMMA PER JOYSTICK NERA	PROTECTION KIT	PROTECTION KIT	GUMMISCHUTZ KIT	PROTECCIÓN DE GOMA



Main color codes:  J1 - JLG Cream,  J2 - JLG Orange,  C4 - Green

 TELECOMANDO
 REMOTE CONTROL
 TÉLÉCOMMANDE





FERNSTEUERUNG 
 TELECOMANDO 



POS	Codice	 Descrizione	 Description	 Designation	 Benennung	 Descripción
9	2646170009	LEVA NERA	LEVER BLACK	LEVIER	HEBEL	PALANCA
10	17550800	KIT PROTEZIONE IN GOMMA PER JOYSTICK ROSSA	PROTECTION	PROTECTION	GUMMISCHUTZ	PROTECCION DE GOMA
10	2646170010	LEVA ROSSA	LEVER RED	LEVIER	HEBEL	PALANCA
12	2646170012	IMPUGNATURA SUPERIORE	GRIP UPPER PART	POIGNÉE	GRIFF	EMPUÑADURA
13	2646170013	IMPUGNATURA INFERIORE	GRIP LOWER PART	POIGNÉE	GRIFF	EMPUÑADURA
14	2646170014	VITE	SCREW	VIS	SCHRAUBE	TORNILLO
15	27005200	KIT ADESIVI	DECALS KIT	KIT AUTOCOLLANTS	AUFKLEBERSATZ	KIT PEGATINAS
16	2646170027	CICALINO COMPLETO DI SCHEDA ELETTRONICA TELECOMANDO	BEEPER FOR REMOTE CONTROL	BUZZER	SUMMER	ZUMBADOR COMPLETO DE TARJETA ELECTRÓNICA TELEMANDO
17	2646170017	PULSANTI	BUTTONS	BOUTONS	DRUCKKNÖPFE	BOTONES
20	2683930001	INTERRUPTORE	SWITCH	INTERRUPTEUR	SCHALTER	INTERRUPTOR
21	2683930002	CHIAVE ACCENSIONE	IGNITION KEY	CLÉ DE DÉMARRAGE	ZÜNDSCHLÜSSEL	LLAVE DE ENCENDIDO
22	2646170022	GUARNIZIONE	GASKET	JOINT	DICHTUNG	GUARNICIÓN
23	2646170023	COPERCHIO INFERIORE	COVER LOWER PART	COUVERCLE	DECKEL	TAPA
24	2646170024	VITE	SCREW	VIS	SCHRAUBE	TORNILLO
25	2646170025	CONNETTORE	CONNECTOR	CONNECTEUR	VERBINGER	CONECTOR
26	2646170026	COPERCHIO CONNETTORE	COVER CONNECTOR	COUVERCLE	DECKEL	TAPA
30	2646170030	CINGHIA	BELT	COURROIE	RIEMEN	CORREA
31	17235800	CAVO TELECOMANDO COMPLETO IIS /200	COMPLETE REMOTE CONTROL CABLE IIS / 200	CÂBLE COMPLET TÉLÉCOMMANDE IIS /200	FERNBEDIENUNGSKABEL KOMPLETT IIS / 200	CABLE TELECOMANDO COMPLETO IIS /200
32	2646170032	CONNETTORE COLLEGAMENTO TELECOMANDO	CONNECTOR FOR REMOTE CONTROL	CONNECTEUR	VERBINGER	CONECTOR



Main color codes:  J1 - JLG Cream,  J2 - JLG Orange,  C4 - Green



 TELECOMANDO
 REMOTE CONTROL
 TÉLÉCOMMANDE

FERNSTEUERUNG 
 TELECOMANDO 



POS	Codice	 Descrizione	 Description	 Designation	 Benennung	 Descripción
33	1684540001	DISPOSITIVO DI COMANDO PER ABILITAZIONE EMERGENZA A TERRA	CONTROL DEVICE FOR ACTIVATING THE EMERGENCY GROUND	DISPOSITIF DE COMMANDE EN CAS D'URGENCE	STEUERVORRICHTUNG IM NOTFALL	DISPOSITIVO DE CONTROL DE EMERGENCIA
34	07027100	PROTEZIONE SINISTRA	LEFT PROTECTION	PROTECTION GAUCHE	ABDECKUNG LINKS	PROTECCIÓN IZQUIERDA
35	07027200	PROTEZIONE DESTRA	RIGHT PROTECTION	PROTECTION DROITE	ABDECKUNG RECHTS	PROTECCIÓN DERECHA
36	27283000	PUNTALINO FEMMINA PER CONNETTORE TELECOMANDO	TERMINAL FEMALE CONNECTOR FOR REMOTE CONTROL	CONNECTEUR FEMELLE	VERBINDUNG	CONECTOR
36	2728300001	PUNTALINO MASCHIO PER CONNETTORE TELECOMANDO	TERMINAL MALE CONNECTOR FOR REMOTE CONTROL	CONNECTEUR	VERBINDER	CONECTOR
37	07320200	SCHERMO LCD (PER RICAMBIO È NECESSARIO IL SN DEL TELECOMANDO)	DISPLAY (AS SPARE IS COMPULSORY THE SN OF REMOTE CONTROL)	ÉCRAN	DISPLAY	PANTALLA
38	2646170006	SCHEDA DI TENSIONE TELECOMANDO	POWER BOARD FOR REMOTE CONTROL	CARTE	PLATINE	PLACA
39	2646170036	KIT CABLAGGIO INTERNO TELECOMANDO	INTERNAL CABLE KIT FOR REMOTE CONTROL	KIT CÂBLES TELECOMMANDE	SATZ KABEL FERNBEDIENUNG	KIT CABLES TELEMANDO



Main color codes:  J1 - JLG Cream,  J2 - JLG Orange,  C4 - Green

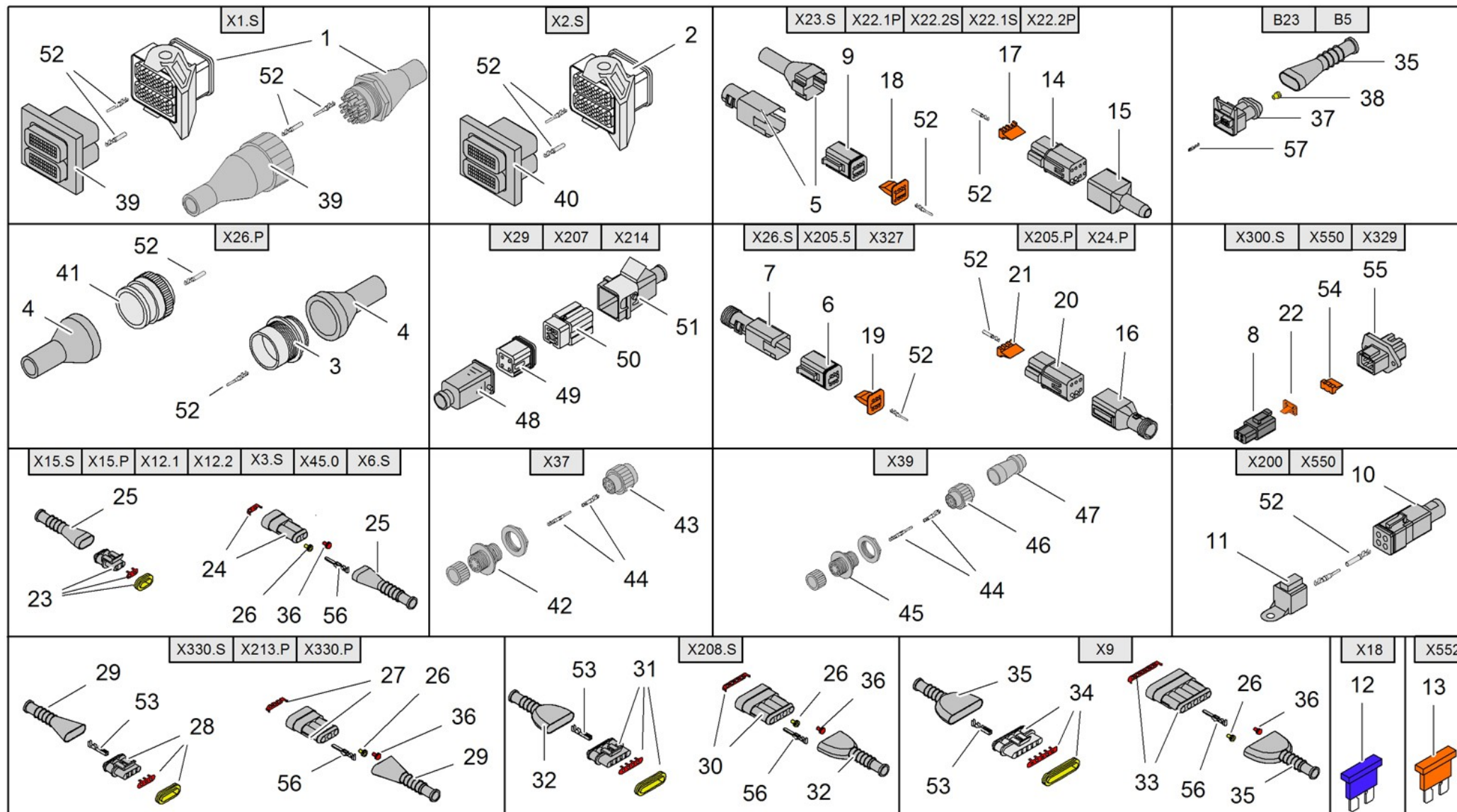

 IMPIANTO ELETTRICO
 ELECTRICAL SYSTEM
 INSTALLATION ÉLECTRIQUE





ELEKTRISCHE ANLAGE 
 INSTALACIÓN ELÉCTRICA 









Main color codes:  J1 - JLG Cream,  J2 - JLG Orange,  C4 - Green



 IMPIANTO ELETTRICO
 ELECTRICAL SYSTEM
 INSTALLATION ÉLECTRIQUE





ELEKTRISCHE ANLAGE 
 INSTALACIÓN ELÉCTRICA 



POS	Codice	 Descrizione	 Description	 Designation	 Benennung	 Descripción
1	1730720066	CONNETTORE	CONNECTOR	CONNECTEUR	VERBINDER	CONECTADOR
1	1764250004	CONNETTORE ROTONDO 47VIE PM (X1) MK2 (DA C170000893)	CONNECTOR 47 WAY ROUND PM (X1) MK2 (FROM C170000893)	CONNECTEUR MK2 (FROM C170000893)	VERBINDER MK2 (FROM C170000893)	CONECTADOR MK2 (FROM C170000893)
2	1730720067	CONNETTORE 64VIE PM (X2) POLAR "A"	CONNECTOR	CONNECTEUR	VERBINDER	CONECTADOR
3	1730720051	CONNETTORE 29 VIE M MOTORE (X26)	CONNECTOR	CONNECTEUR	VERBINDER	CONECTOR
4	1730720054	CAPPUCCIO POSTERIORE	CAP	CAPUCHON	KAPPE	CAPUCHO
5	1730720035	COVER POSTERIORE RIGIDA PER CONNETTORE 8 VIE MASCHIO	PROTECTION	PROTECTION	SCHUTZ	PROTECCION
5	1757250025	CAPPUCCIO POSTERIORE PER CONNETTORE MASCHIO	CAP	CAPUCHON	KAPPE	TAPA
6	1730720037	CONNETTORE 6 VIE MASCHIO	6-WAY MALE CONNECTOR	CONNECTEUR 6 VOIES MÂLE	6-WEGE-VERBINDER	CONECTOR 6 VÍAS
7	1730720039	COVER POSTERIORE RIGIDA PER CONNETTORE 6 VIE MASCHIO	PROTECTION	PROTECTION	SCHUTZ	PROTECCION
8	1757250028	CONNETTORE 4 VIE MASCHIO DEUTSCH PF POTENZA 25A	4-WAY MALE CONNECTOR 25A	CONNECTEUR 4 VOIES MÂLE 25A	4-WEGE-VERBINDER STIFT 25A	CONECTOR 4 VÍAS MACHO 25A
9	1730720033	CONNETTORE 8 VIE MASCHIO	8-WAY MALE CONNECTOR	CONNECTEUR 8 VOIES MÂLE	8-WEGE-VERBINDER STIFT	CONECTOR 8 VÍAS MACHO
10	1763330001	CONNETTORE 4 VIE MASCHIO DEUTSCH	4-WAY MALE CONNECTOR DEUTSCH	CONNECTEUR 4 VOIES MÂLE DEUTSCH	4-WEGE-VERBINDER STIFT DEUTSCH	CONECTOR 4 VÍAS MACHO DEUTSCH



Main color codes:  J1 - JLG Cream,  J2 - JLG Orange,  C4 - Green

 IMPIANTO ELETTRICO
 ELECTRICAL SYSTEM
 INSTALLATION ÉLECTRIQUE





ELEKTRISCHE ANLAGE 
 INSTALACIÓN ELÉCTRICA 



POS	Codice	 Descrizione	 Description	 Designation	 Benennung	 Descripción
11	1763330002	CAPPUCCIO FRONTALE CONNETTORE 4 VIE MASCHIO DEUTSCH	CAP FOR 4-WAY MALE CONNECTOR DEUTSCH	PAC CONNECTEUR 4 VOIES MÂLE DEUTSCH	CAP 4-WEGE-VERBINDER STIFT DEUTSCH	CAP CONECTOR 4 VÍAS MACHO DEUTSCH
12	07700700	FUSIBILE A LAMA 25A	FUSE 25A	FUSIBLE 25A	SICHERUNG 25A	FUSIBLE 25A
13	05760700	FUSIBILE A LAMA 5A	FUSE 5A	FUSIBLE 5A	SICHERUNG 5A	FUSIBLE 5A
14	1730720029	CONNETTORE 8 VIE FEMMINA	8-WAY FEMALE CONNECTOR	CONNECTEUR 8 VOIES FEMELLE	8-WEGE-VERBINDER BUCHSE	CONECTOR 8 VÍAS HEMBRA
15	1730720031	COVER POSTERIORE RIGIDA PER CONNETTORE 8 VIE FEMMINA	PROTECTION	PROTECTION	SCHUTZ	PROTECCION
15	1757250026	CAPPUCCIO POSTERIORE PER CONNETTORE FEMMINA	CAP	CAPUCHON	KAPPE	TAPA
16	1730720084	COVER POSTERIORE RIGIDA PER CONNETTORE 6 VIE FEMMINA	PROTECTION	PROTECTION	SCHUTZ	PROTECCION
16	1757250027	CAPPUCCIO POSTERIORE PER CONNETTORE 6 VIE FEMMINA	CAP	CAPUCHON	KAPPE	TAPA
17	1730720030	PIASTRINA DI BLOCCAGGIO CONNETTORE 8 VIE FEMMINA	PLATE	PLAQUE	PLATTE	PLACA
18	1730720034	PIASTRINA DI BLOCCAGGIO CONNETTORE 8 VIE MASCHIO	PLATE	PLAQUE	PLATTE	PLACA



Main color codes:  J1 - JLG Cream,  J2 - JLG Orange,  C4 - Green



 IMPIANTO ELETTRICO
 ELECTRICAL SYSTEM
 INSTALLATION ÉLECTRIQUE





ELEKTRISCHE ANLAGE 
 INSTALACIÓN ELÉCTRICA 



POS	Codice	 Descrizione	 Description	 Designation	 Benennung	 Descripción
19	1730720038	PIASTRINA DI BLOCCAGGIO CONNETTORE 6 VIE MASCHIO	PLATE	PLAQUE	PLATTE	PLACA
20	1730720041	CONNETTORE 6 VIE FEMMINA	6-WAY FEMALE CONNECTOR	CONNECTEUR 6 VOIES FEMELLE	6-WEGE-VERBINDER BUCHSE	CONECTOR 6 VÍAS HEMBRA
21	1730720042	PIASTRA BLOCCAGGIO CONNETTORE 6 VIE FEMMINA	CONNECTOR	CONNECTEUR	VERBINDER	CONECTADOR
22	1757250029	PIASTRINA DI BLOCCAGGIO CONNETTORE 4 VIE M POTENZA 25A	PLATE	PLAQUE	PLATTE	PLACA
23	1757250031	CONNETTORE SUPERSEAL PF 2 VIE	CONNECTOR	CONNECTEUR	VERBINDER	CONECTADOR
24	1757250032	CONNETTORE SUPERSEAL PM 2 VIE	CONNECTOR	CONNECTEUR	VERBINDER	CONECTADOR
25	1757250033	CAPPUCCIO POSTERIOERE CONNETTORE SUPERSEAL 2 VIE	CAP	CAPUCHON	KAPPE	CAPUCHO
26	1757250043	GOMMINO TENUTA PER CAVI CONNETTORI SUPERSEAL	RUBBER SEAL	JOINT EN CAOUTCHOUC	GUMMIDICHTUNG	JUNTA DE GOMA
27	1757250035	CONNETTORE SUPERSEAL PM 3 VIE	CONNECTOR	CONNECTEUR	VERBINDER	CONECTADOR
28	1757250034	CONNETTORE SUPERSEAL PF 3 VIE	CONNECTOR	CONNECTEUR	VERBINDER	CONECTADOR
29	1757250036	CAPPUCCIO POSTERIOERE CONNETTORE SUPERSEAL 3 VIE	CAP	CAPUCHON	KAPPE	CAPUCHO



Main color codes:  J1 - JLG Cream,  J2 - JLG Orange,  C4 - Green



 IMPIANTO ELETTRICO
 ELECTRICAL SYSTEM
 INSTALLATION ÉLECTRIQUE





ELEKTRISCHE ANLAGE 
 INSTALACIÓN ELÉCTRICA 



POS	Codice	 Descrizione	 Description	 Designation	 Benennung	 Descripción
30	1757250038	CONNETTORE SUPERSEAL PM 4 VIE	CONNECTOR	CONNECTEUR	VERBINDER	CONECTADOR
31	1757250037	CONNETTORE SUPERSEAL PF 4 VIE	CONNECTOR	CONNECTEUR	VERBINDER	CONECTADOR
32	1757250039	CAPPUCCIO POSTERIORE CONNETTORE SUPERSEAL 4 VIE	CAP	CAPUCHON	KAPPE	CAPUCHO
33	1757250041	CONNETTORE SUPERSEAL PM 5 VIE	CONNECTOR	CONNECTEUR	VERBINDER	CONECTADOR
34	1757250040	CONNETTORE SUPERSEAL PF 5 VIE	CONNECTOR	CONNECTEUR	VERBINDER	CONECTADOR
35	1757250042	CAPPUCCIO POSTERIOERE CONNETTORE SUPERSEAL 5 VIE	CAP	CAPUCHON	KAPPE	CAPUCHO
35	1757250056	CONNETTORE SUPERSEAL PF 6 VIE	CONNECTOR	CONNECTEUR	VERBINDER	CONECTADOR
35	1757250057	CAPPUCCIO POSTERIOERE CONNETTORE SUPERSEAL 6-7 VIE	CAP	CAPUCHON	KAPPE	CAPUCHO
36	1757250046	GOMMINO TENUTA TAPPO PER CONNETTORI SUPERSEAL	RUBBER SEAL	JOINT EN CAOUTCHOUC	GUMMIDICHTUNG	JUNTA DE GOMA
37	1757250044	CONNETTORE JPT 2 VIE PER ELETTROVALVOLE	CONNECTOR	CONNECTEUR	VERBINDER	CONECTADOR
38	1757250045	GOMMINO TENUTA PER CAVI CONNETTORI JPT	RUBBER SEAL	JOINT EN CAOUTCHOUC	GUMMIDICHTUNG	JUNTA DE GOMA
39	1730720064	CONNETTORE 50VIE PF (X1)	CONNECTOR 50 WAY PF (X1)	CONNECTEUR	VERBINDER	CONECTADOR



Main color codes:  J1 - JLG Cream,  J2 - JLG Orange,  C4 - Green



 IMPIANTO ELETTRICO
 ELECTRICAL SYSTEM
 INSTALLATION ÉLECTRIQUE





ELEKTRISCHE ANLAGE 
 INSTALACIÓN ELÉCTRICA 



POS	Codice	 Descrizione	 Description	 Designation	 Benennung	 Descripción
39	1764250006	CONNETTORE ROTONDO 47VIE PF (X1) MK2 (DA C170000893)	CONNECTOR 47 WAY ROUND PF (X1) MK2 (FROM C170000893)	CONNECTEUR MK2 (FROM C170000893)	VERBINDER MK2 (FROM C170000893)	CONECTADOR MK2 (FROM C170000893)
40	1730720065	CONNETTORE 64VIE PF (X2) POLAR A	CONNECTOR	CONNECTEUR	VERBINDER	CONECTADOR
41	1730720059	CONNETTORE 29 VIE F MOTORE (X26)	CONNECTOR	CONNECTEUR	VERBINDER	CONECTADOR
42	1730720019	CONNETTORE 19 VIE F SCATOLA CELLA (X37)	CONNECTOR 19 WAY FEMALE CELL BOX (X 37)	CONNECTEUR	VERBINDER	CONECTADOR
43	1730720020	CONNETTORE 19 VIE M SCATOLA CELLA (X37)	CONNECTOR 19 WAY MALE CELL BOX (X 37)	CONNECTEUR	AUFKLEBER	PEGATINA
44	1730720022	TERMINALE MASCHIO 16A (X37)	TERMINAL MALE 16A (X37)	BORNE	TERMINAL MALE	MALE TERMINAL
44	1730720023	TERMINALE FEMMINA 16A (X37)	TERMINAL FEMALE 16A (X37)	BORNE FEMELLE	TERMINAL FEMALE	TERMINAL HEMBRA
44	1730720025	TERMINALE F 0,25- 0,50 MMQ (X39)	TERMINAL F 0.25-0.50 MMQ (X39)	TERMINAL	TERMINAL	TERMINAL
44	1730720027	TERMINALE M 0,25- 0,50 MMQ (X39)	TERMINAL M 0.25-0.50 MMQ (X39)	TERMINAL	TERMINAL	TERMINAL
45	1730720024	CONNETTORE 12 VIE F SCATOLA CELLA	CONNECTOR 12 WAY FEMALE CELL BOX	CONNECTEUR	VERBINDER	CONECTADOR
46	1730720026	CONNETTORE 12 VIE M SCATOLA CELLA (X39)	CONNECTOR 12 WAY MALE BOX CELL (X39)	CONNECTEUR	VERBINDER	CONECTADOR
47	1730720028	FERMA CAVO CONNETTORE 12 VIE M SCATOLA CELLA (X39)	LOCK CABLE CONNECTOR 12 WAY MALE BOX CELL (X39)	ARRÊT CÂBLE	KABELHALTERUNG	PARADA DE CABLE



Main color codes:  J1 - JLG Cream,  J2 - JLG Orange,  C4 - Green



 IMPIANTO ELETTRICO
 ELECTRICAL SYSTEM
 INSTALLATION ÉLECTRIQUE





ELEKTRISCHE ANLAGE 
 INSTALACIÓN ELÉCTRICA 



POS	Codice	 Descrizione	 Description	 Designation	 Benennung	 Descripción
48	1730720083	CUSTODIA 3 POLI GRIGIA VOLANTE PER CONN.PM 4+1VIE 230/110V (X29)	HOUSING 3 POLE GREY FOR CONN. PM 4 + 1 WAY 230V / 110V (X29)	LOGEMENT	GEHÄUSE	ALOJAMIENTO
49	1730720082	FRUTTO CONN.PM 4+1VIE 230/110V (X29)	CONNECTOR PM 4 + 1 WAY 230V / 110V (X29)	CONNECTEUR	VERBINDER	CONECTADOR
50	1730720080	FRUTTO CONN. PF 4+1 VIA 230/110V (X29)	CONNECTOR PF 4 + 1 WAY 230V / 110V (X29)	CONNECTEUR	VERBINDER	CONECTADOR
51	1730720081	CUSTODIA 3 POLI GRIGIA CON GANCIO PER CONN. PF 4+1 VIA 230/110V (X29)	HOUSING 3 POLE GREY WITH HOOK FOR CONN. PF 4 + 1 ROUTE 230 / 110V (X29)	LOGEMENT	GEHÄUSE	ALOJAMIENTO
52	1730720031	COVER POSTERIORE RIGIDA PER CONNETTORE 8 VIE FEMMINA	PROTECTION	PROTECTION	SCHUTZ	PROTECCION
52	1730720032	TERMINALE MASCHIO CAVO 0.75-1.5	TERMINAL MALE CABLE 0.75-1.5	MALE TERMINAL	TERMINAL MALE	MALE TERMINAL
52	1730720036	TERMINALE FEMMINA CONNETTORE M CAVO 0.5-1	TERMINAL FEMALE MALE CONNECTOR CABLE 0.5-1	BORNE FEMELLE	TERMINAL FEMALE	TERMINAL HEMBRA
52	1730720040	TERMINALE FEMMINA (X24)	TERMINAL FEMALE (X24)	BORNE FEMELLE (X24)	TERMINAL FEMALE (X24)	TERMINAL HEMBRA (X24)
52	1730720043	TERMINALE MASCHIO (X24) DA 0.5 A 0.75	TERMINAL MALE (X24) DA 0.5 A 0.75	BORNE MALE (X24)	TERMINAL MALE (X24)	TERMINAL MACHO (X24)
52	1730720055	CONTATTO MASCHIO 25A CAVO 2.5-4	CONTACT MALE 25A CABLE 2.5-4	CONTACT MALE 25A	CONTACT MALE 25A	CONTACT MALE 25A



Main color codes:  J1 - JLG Cream,  J2 - JLG Orange,  C4 - Green



 IMPIANTO ELETTRICO
 ELECTRICAL SYSTEM
 INSTALLATION ÉLECTRIQUE

ELEKTRISCHE ANLAGE 
 INSTALACIÓN ELÉCTRICA 

POS	Codice	 Descrizione	 Description	 Designation	 Benennung	 Descripción
52	1730720056	TAPPO SIZE 12-16 (X26)	CAP SIZE 12-16 (X26)	CAP TAILLE 12-16 (X26)	CAP SIZE 12-16 (X26)	CAP TAMAÑO 12-16 (X26)
52	1730720057	TAPPO SIZE 16 (X26)	CAP SIZE 16 (X26)	PLUG SIZE 16 (X26)	PLUG SIZE 16 (X26)	MACHO TALLA 16 (X26)
52	1730720058	CONTATTO MASCHIO 7.5A (X26)	CONTACT PIN 7.5A (X26)	CONTACT PIN 7.5A (X26)	CONTACT PIN 7.5A (X26)	CONTACT 7.5A (X26)
52	1730720061	CONTATTO FEMMINA 7.5A (X26)	CONTACT FEMALE 7.5A (X26)	CONTACTER 7,5 FEMELLE (X26)	CONTACT FEMALE 7.5A (X26)	CONTACT 7.5A FEMENINO (X26)
52	1730720068	TAPPO SIZE 20 (X1)	CAP SIZE 20 (X1)	PLUG SIZE 20 (X1)	PLUG SIZE 20 (X1)	TAMAÑO DE ENCHUFE 20 (X1)
52	1730720069	CONTATTO FEMMINA 25A CONNETTORE M CAVO 2.5-4	CONTACT FEMALE 25A MALE CONNECTOR CABLE 2.5-4	CONTACT FEMELLE 25A	KONTAKT BUCHSE 25A	CONTACT HEMBRA 25A
53	1757250048	PUNTALINO FEMMINA PER SUPERSEAL	FERRULE FEMALE FOR SUPERSEAL	FERRULE	NUTMUTTER	ANILLO
54	1757250030	PIASTRINA DI BLOCCAGGIO CONNETTORE 4 VIE FEMMINA POTENZA 25A	PLATE	PLAQUE	PLATTE	PLACA
55	1757250018	CONNETTORE 4 VIE DEUTSCH A PARETE PM POTENZA 25A (X300)	CONNECTOR	CONNECTEUR	VERBINDER	CONECTADOR
56	1757250049	PUNTALINO MASCHIO PER SUPERSEAL	FERRULE MALE FOR SUPERSEAL	FERRULE	NUTMUTTER	ANILLO
57	1739150047	CONTATTO FEMMINA PER CONNETTORE JPT	CONTACT FEMALE FOR CONNECTOR JPT	CONTACT FEMELLE POUR CONNECTEUR JPT	KONTAKT BUCHSE FÜR JPT VERBINDER	CONTACTO HEMBRA PARA CONECTOR JPT



Main color codes:  J1 - JLG Cream,  J2 - JLG Orange,  C4 - Green

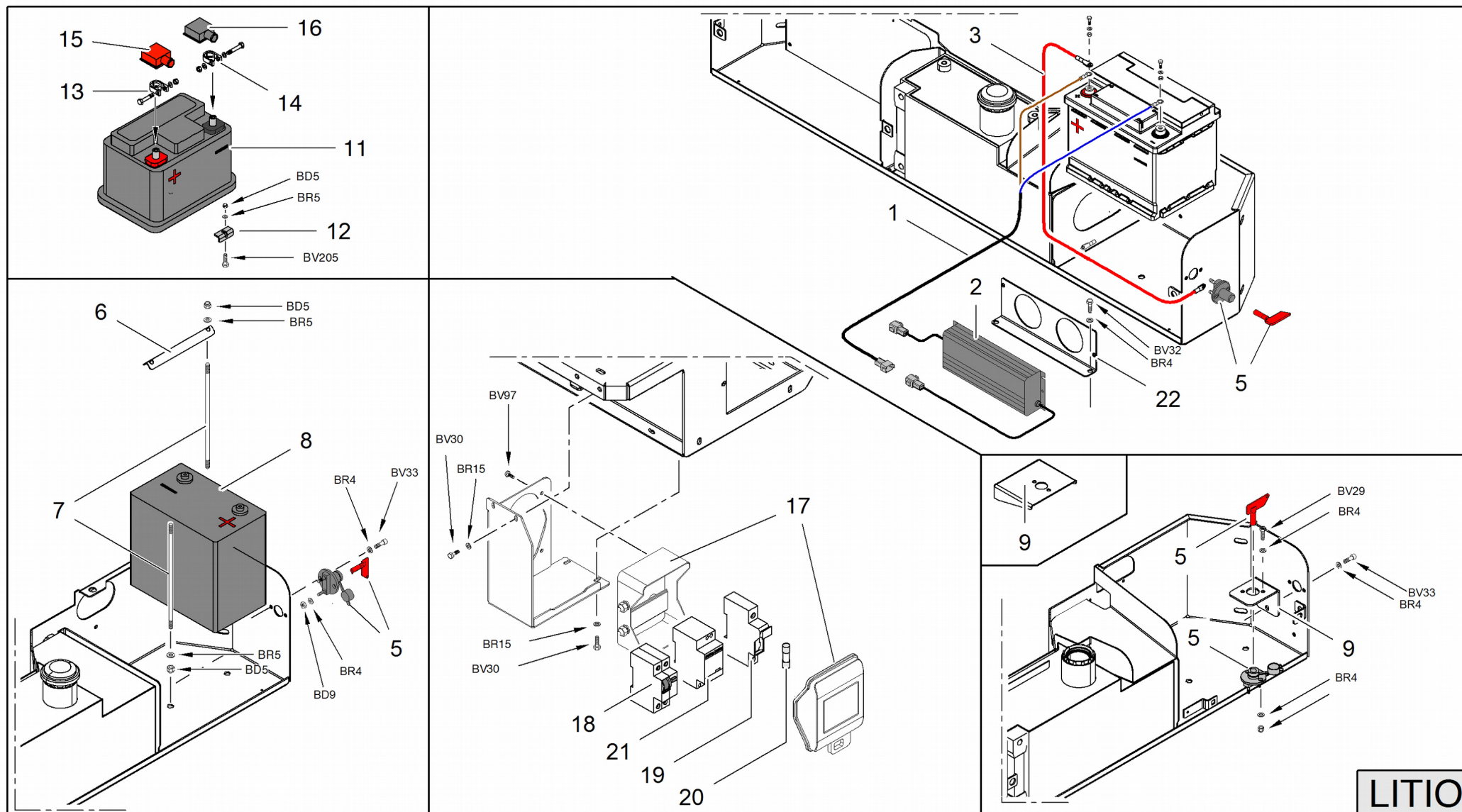

 IMPIANTO ELETTRICO
 ELECTRICAL SYSTEM
 INSTALLATION ÉLECTRIQUE



ELEKTRISCHE ANLAGE 
 INSTALACIÓN ELÉCTRICA 











LITIO



Main color codes:  J1 - JLG Cream,  J2 - JLG Orange,  C4 - Green



 IMPIANTO ELETTRICO
 ELECTRICAL SYSTEM
 INSTALLATION ÉLECTRIQUE





ELEKTRISCHE ANLAGE 
 INSTALACIÓN ELÉCTRICA 



POS	Codice	 Descrizione	 Description	 Designation	 Benennung	 Descripción
1	1757260008	CABLAGGIO DA BATTERIA A CARICABATTERIA CON DIODO E CONNETTORE	WIRING FROM BATTERY TO CHARGER WITH DIODE AND CONNECTOR	CÂBLAGE	VERKABELUNG	CABLEADO
1	1764260002	LINEA DA ALIMENTATORE A BATTERIA COMPLETA DI CONNETTORI E DIODO	LINE FROM CHARGER TO BATTERY WITH CONNECTORS AND DIODE	LIGNE	LEITUNG	LÍNEA
2	1757250007	ALIMENTATORE ELETTRONICO 285W REGOLABILE IP65 PER BATTERIE 55-75 AH COMPLETO DI CONNETTORI	ELECTRONIC BALLAST	ALIMENTATEUR ÉLECTRONIQUE	ELEKTRONISCHES NETZGERÄT	ALIMENTADOR ELETRÓNICO
2	17572600081	CONNETTORE DEUTSCH 2 VIE COMPLETO DI DIODO CON PROTEZIONE	DEUTSCH CONNECTOR 2 WAYS OF COMPLETE WITH PROTECTION DIODE	CONNECTEUR	VERBINDER	CONECTOR
3	1764260001	CAVO POSITIVO BATTERIA	12V BATTERY CABLE	CÂBLE	KABEL	CABLE
5	04774900	STACCA BATTERIA	BATTERY CUT-OFF DEVICE	COUPE BATTERIE	BATTERIETRENNSCH ALTER	CORTA-BATERÍA
6	055618Y1	LAMIERA	PLATE	TÔLE	BLECH	CHAPA
7	06551000	TIRANTE	TIE ROD	TIRANT	TURMGESTÄNGE	TIRANTE
8	26550700	BATTERIA	BATTERY	BATTERIE	BATTERIE	BATERÍA
9	069226Y1	SUPPORTO	SUPPORT	SUPPORT	HALTERUNG	SOPORTE
9	074167Y1	PIEGATO PER STACCABATTERIA MK2 (FROM C170000893)	SUPPORT FOR BATTERY CUTOFF MK2 (FROM C170000893)	SUPPORT POUR COUPE BATTERIE MK2 (FROM C170000893)	HALTERUNG FÜR BATTERIETRENNSCH ALTER MK2 (FROM C170000893)	SOPORTE PARA DESCONECTADOR DE BATERÍA MK2 (FROM C170000893)
11	27668600	BATTERIA AGM S&S 12V 60AH 680A L02	BATTERY AGM S&S 12V 60AH 680A L02	BATTERIE AGM S&S 12V 60AH 680A L02	BATTERIE AGM S&S 12V 60AH 680A L02	BATERÍA AGM S&S 12V 60AH 680A L02

Main color codes:  J1 - JLG Cream,  J2 - JLG Orange,  C4 - Green

 IMPIANTO ELETTRICO
 ELECTRICAL SYSTEM
 INSTALLATION ÉLECTRIQUE

ELEKTRISCHE ANLAGE 
 INSTALACIÓN ELÉCTRICA 





POS	Codice	 Descrizione	 Description	 Designation	 Benennung	 Descripció
12	051705Y1	PIATTO FERMO BATTERIA	BATTERY BLOCK PLATE	PLACQUE D'ATTERT BATTERIE	BLOCKPLATTE BATTERIE	PLATO DE SUJECIÓN BATERÍA
13	1739150023	MORSETTO POSITIVO A C PER BATTERIA M10	POSITIVE BATTERY CLAMP "C" M10	BORNE POSITIVE A C POUR BATTERIE M10	POSITIVE KLEMME FÜR BATTERIE M10	BORNE POSITIVO A C PARA BATERÍA M10
14	1739150025	MORSETTO NEGATIVO A C PER BATTERIA M10	NEGATIVE BATTERY TERMINAL C M10	BORNE NEGATIVE A C POUR BATTERIE M10	NEGATIVE KLEMME FÜR BATTERIE M10	BORNE NEGATIVO A C PARA BATERÍA M10
15	2632920007	COPRI POLI BATTERIA QUADRATO ROSSO	POLE BATTERY COVER RED SQUARE	POLE CACHE BATTERIE RED SQUARE	POLE BATTERY COVER RED SQUARE	TAPAS DE LA BATERIA
16	2632920008	COPRI POLI BATTERIA QUADRATO NERO	POLE BATTERY COVER BLACK SQUARE	POLE BATTERIE COUVERTURE CARRÉ NOIR	POLE BATTERY COVER BLACK SQUARE	TAPAS BATERIA
17	1730720006	SCATOLA ELETTRICA MAGNETOTERMICO FORATA CIAM	ELECTRICAL MAGNETOTHERMIC BOX DRILLED CIAM	BOÎTE ÉLECTRIQUE	ELEKTROGEHÄUSE	CAJA ELÉCTRICA
17	1757250008	SCATOLA ELETTRICO PLASTICA 6 MODULI BI COPERCHIO TRASPARENTE	ELECTRICAL BOX	BOÎTE ÉLECTRIQUE	SCHALTKASTEN	CAJA ELÉCTRICA
18	1556350015	INTERUTTORE AUTOMATICO MAGNETOTERMICO 220V	AUTOMATIC THERMAL SWITCH 220V	INTERRUPTEUR	INTERRUPTORES	INTERRUPTOR
18	1556350063	INTERUTTORE AUTOMATICO MAGNETOTERMICO 110-120V 25A (FINO A C170000355 MONTATO C16 SU MACCHINE 120V)	AUTOMATIC THERMAL SWITCH 110-120V 25A (UNTIL C170000355 MOUNTED C16 ON 120V MACHINES)	INTERRUPTEUR	SCHALTER	INTERRUPTOR
19	1730720015	PORTAFUSIBILE A TUBO 220/110V	FUSE HOLDER TUBE 220/110V	BOÎTE À FUSIBLES	SICHERUNGSKASTEN	PORTAFUSIBLES



Main color codes:  J1 - JLG Cream,  J2 - JLG Orange,  C4 - Green



 IMPIANTO ELETTRICO

 ELECTRICAL SYSTEM



 INSTALLATION ÉLECTRIQUE
ELEKTRISCHE ANLAGE INSTALACIÓN ELÉCTRICA 



POS	Codice	 Descrizione	 Description	 Designation	 Benennung	 Descripción
20	1730720017	FUSIBILE A TUBO 10A	TUBE FUSE 10A	FUSIBLE	SICHERUNG	FUSIBLE
21	1757250006	TELERUTTORE 4POLI 63A CA/CC	RELAY	RELAIS	RELAIS	RELÉ
22	076841Y1	STAFFA FISSAGGIO ALIMENTATORE	PLATE SUPPORT BATTERY CHARGER	BRIDE	FLANSCH	BRIDA

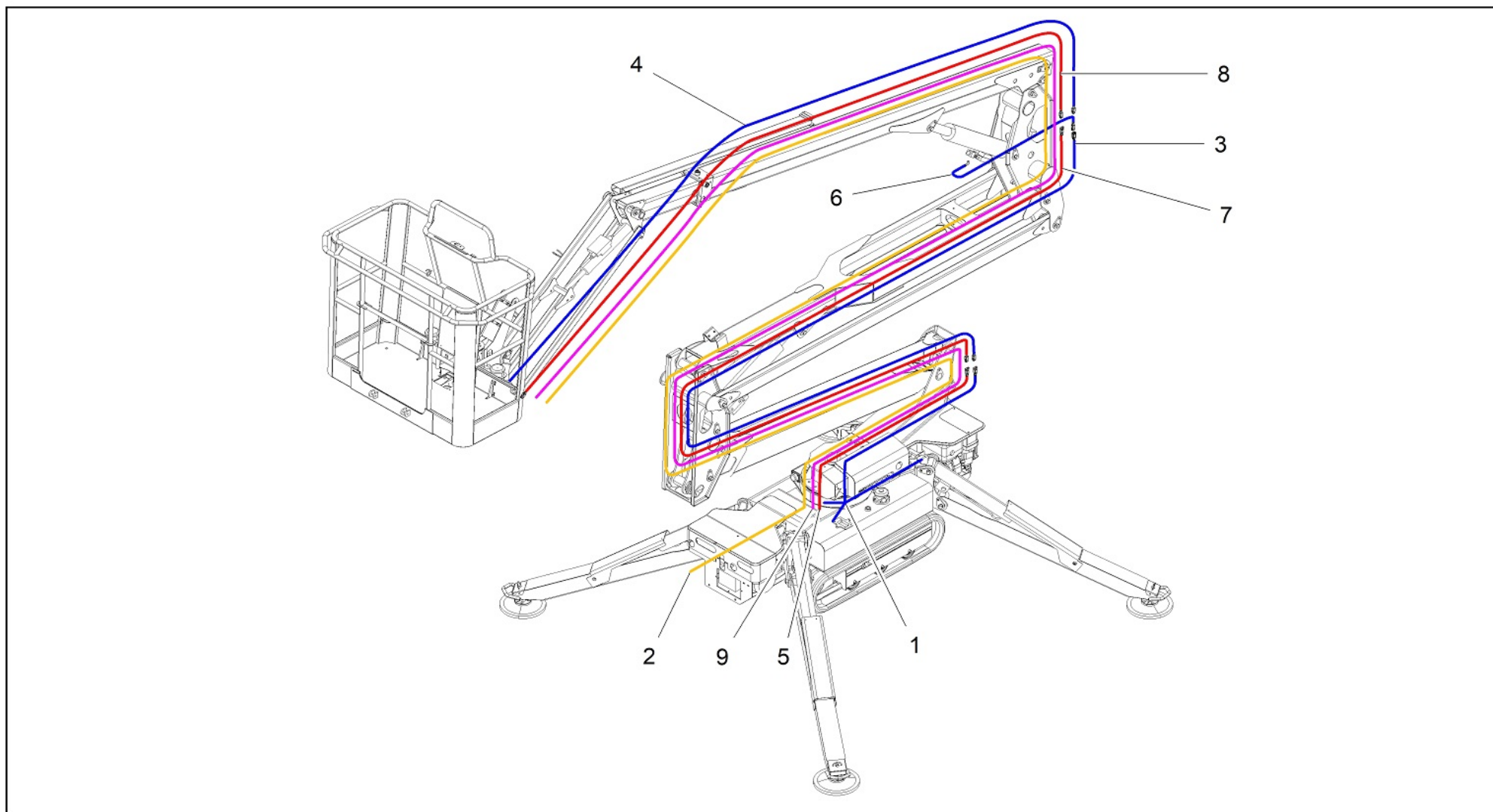

-  IMPIANTO ELETTRICO
-  ELECTRICAL SYSTEM
-  INSTALLATION ÉLECTRIQUE





- ELEKTRISCHE ANLAGE 
- INSTALACIÓN ELÉCTRICA 









Main color codes:  J1 - JLG Cream,  J2 - JLG Orange,  C4 - Green



 IMPIANTO ELETTRICO
 ELECTRICAL SYSTEM
 INSTALLATION ÉLECTRIQUE





ELEKTRISCHE ANLAGE 
 INSTALACIÓN ELÉCTRICA 



POS	Codice	 Descrizione	 Description	 Designation	 Benennung	 Descripción
1	17307200	KIT IMPIANTO GENERALE LL1775-X17JP-X500AJ-LL2010-X20JP-X600AJ (FINO A SN C170000892)	MAIN HARNESS KIT LL1775-X17JP-X500AJ-LL2010-X20JP-X600AJ (UNTIL SN C170000892)	KIT COMPOSANTS ÉLECTRIQUES	SATZ ELEKTRISCHE BAUTEILE	KIT COMPONENTES ELÉCTRICOS
1	17642500	KIT IMPIANTO GENERALE LL1775-X17JP-X500AJ-LL2010-X20JP-X600AJ (DA SN C170000893)	MAIN HARNESS KIT LL1775-X17JP-X500AJ-LL2010-X20JP-X600AJ (FROM SN C170000893)	KIT COMPOSANTS ÉLECTRIQUES	SATZ ELEKTRISCHER BAUTEILE	JUEGO COMPONENTES ELÉCTRICOS
3	1764300002	CAVO PROLUNGA 7POLI DA 1 BRACCIO A 3 BRACCIO MK2 (DA C170000893)	EXTENSION CABLE 7WAY FROM 1 BOOM TO 3 BOOM MK2 (FROM C170000893)	CÂBLE	KABEL	CABLE
4	1730790001	CABLAGGIO LL2010 CESTO SENZA SCATOLA IN ALLUMINO E RELATIVO IMPIANTO INTERNO	WIRING LL2010 BASKET WITHOUT BOX ALUMINIUM AND ITS INTERNAL INSTALLATION	CÂBLAGE	VERKABELUNG	CABLEADO
5	1764290002	CAVO PROLUNGA 220-110V DA BASE A PRIMO BRACCIO (FINO A C170000892)	EXTENSION CABLE 220V-110V FROM BASE TO 1 BOOM (UNTIL SN C170000892)	CÂBLE	KABEL	CABLE
5	1764290007	CAVO PROLUNGA 220-110V DA BASE A PRIMO BRACCIO LL1775-LL2010 CONNETTORI SOURIAU (DA C170000893)	EXTENSION CABLE 220-110V FROM BASE TO FIRST ARM LL1775-LL2010 SOURIAU CONNECTORS (FROM C170000893)	CÂBLE	KABEL	CABLE



Main color codes:  J1 - JLG Cream,  J2 - JLG Orange,  C4 - Green



 IMPIANTO ELETTRICO
 ELECTRICAL SYSTEM
 INSTALLATION ÉLECTRIQUE

ELEKTRISCHE ANLAGE 
 INSTALACIÓN ELÉCTRICA 



POS	Codice	 Descrizione	 Description	 Designation	 Benennung	 Descripción
6	1730720094	CAVO COMPLETO PER SENSORE DI POSIZIONE 3 CILINDRO BRACCIO	CABLE ASSEMBLY FOR POSITION SENSOR 3 BOOM CYLINDER	CÂBLE COMPLET POUR CAPTEUR DE POSITION 3° CYLINDRE BRAS	KABEL KOMPLETT FÜR POSITIONSSENSOR 3. AUSLEGERARM- ZYLINDER	CABLE COMPLETO PARA SENSOR DE POSICIÓN 3ERO CILINDRO BRAZO
6	1764300004	CAVO SENSORE CILINDRO 3 BRACCIO MK2 (DA C170000893)	CABLE CYLINDER SENSOR 3 BOOM MK2 (FROM C170000893)	CÂBLE	KABEL	CABLE
7	1764290001	CAVO PROLUNGA 220-110V DA PRIMO BRACCIO A 3 BRACCIO (FINO A C170000892)	EXTENSION CABLE 220V-110V FROM 1 BOOM TO 3 BOOM (UNTIL SN C170000892)	CÂBLE	KABEL	CABLE
7	1764290008	CAVO PROLUNGA 220-110V DA PRIMO BRACCIO A TERZO BRACCIO LL1775- LL2010 CONNETTORI SOURIAU (DA C170000893)	EXTENSION CABLE 220-110V FROM FIRST ARM TO THIRD ARM LL1775-LL2010 SOURIAU CONNECTORS (FROM C170000893)	CÂBLE	KABEL	CABLE
8	1764300001	CAVO PROLUNGA 220-110V SFILO (FINO A C170000892)	EXTENSION CABLE 220V-110V EXTENSION BOOM (UNTIL SN C170000892)	CÂBLE	KABEL	CABLE
8	1764300006	CAVO PROLUNGA 220-110V SFILO LL2010 CONNETTORI SOURIAU (DA C170000893)	EXTENSION CABLE 220-110V SFILO LL2010 SOURIAU CONNECTORS (FROM C170000893)	CÂBLE	KABEL	CABLE



Main color codes:  J1 - JLG Cream,  J2 - JLG Orange,  C4 - Green



 ADESIVI
 STICKER
 AUTOCOLLANT





AUFKLEBER 
PEGATINA 



DECALS LIST



Main color codes:  **J1** - JLG Cream,  **J2** - JLG Orange,  **C4** - Green



 ADESIVI
 STICKER
 AUTOCOLLANT





AUFKLEBER 
 PEGATINA 



POS	Codice	 Descrizione	 Description	 Designation	 Benennung	 Descripción
0	06039600	ADESIVO	STICKER	AUTOCOLLANT	AUFKLEBER	PEGATINA
0	06039700	ADESIVO	STICKER	AUTOCOLLANT	AUFKLEBER	PEGATINA
0	06040100	ADESIVO	STICKER	AUTOCOLLANT	AUFKLEBER	PEGATINA
0	06040300	ADESIVO	STICKER	AUTOCOLLANT	AUFKLEBER	PEGATINA
0	06040500	ADESIVO	STICKER	AUTOCOLLANT	AUFKLEBER	PEGATINA
0	06040900	ADESIVO	STICKER	AUTOCOLLANT	AUFKLEBER	PEGATINA
0	06041200	ADESIVO	STICKER	AUTOCOLLANT	AUFKLEBER	PEGATINA
0	06041300	ADESIVO	STICKER	AUTOCOLLANT	AUFKLEBER	PEGATINA
0	06041600	ADESIVO CARBURANTE BENZINA COLORE VERDE L=60 X 80 (**)	DECAL	AUTOCOLLANT	AUFKLEBER	PEGATINA
0	06042400	ADESIVO	STICKER	AUTOCOLLANT	AUFKLEBER	PEGATINA
0	06043900	ADESIVO	STICKER	AUTOCOLLANT	AUFKLEBER	PEGATINA
0	06044000	ADESIVO	STICKER	AUTOCOLLANT	AUFKLEBER	PEGATINA
0	06056300	ADESIVO	STICKER	AUTOCOLLANT	AUFKLEBER	PEGATINA
0	06060000	ADESIVO	STICKER	AUTOCOLLANT	AUFKLEBER	PEGATINA
0	06085900	ADESIVO	STICKER	AUTOCOLLANT	AUFKLEBER	PEGATINA
0	06086000	ADESIVO	STICKER	AUTOCOLLANT	AUFKLEBER	PEGATINA
0	06086700	ADESIVO	STICKER	AUTOCOLLANT	AUFKLEBER	PEGATINA
0	06136900	ADESIVO PUNTI INGRASSAGGIO Ø 55 TESTO NERO - SFONDO BIANCO (**)	STICKER GREASE POINTS Ø 55	AUTOCOLLANT POINTS GRAISSANGE Ø 55 TEXTE NOIR - FOND BLANC (**)	AUFKLEBER SCHMIERPUNKTE Ø 55, SCHWARZER TEXT - WEIßER UNTERGRUND	PEGATINS PUNTOS ENGRASE Ø 55 TEXTO NEGRO - FONDO BLANCO (**)
0	06164600	ADESIVO	STICKER	AUTOCOLLANT	AUFKLEBER	PEGATINA
0	06164700	ADESIVO	STICKER	AUTOCOLLANT	AUFKLEBER	PEGATINA
0	06165000	ADESIVO	STICKER	AUTOCOLLANT	AUFKLEBER	PEGATINA
0	06214200	ADESIVO	STICKER	AUTOCOLLANT	AUFKLEBER	PEGATINA



Main color codes:  J1 - JLG Cream,  J2 - JLG Orange,  C4 - Green



 ADESIVI
 STICKER
 AUTOCOLLANT





AUFKLEBER 
 PEGATINA 



POS	Codice	 Descrizione	 Description	 Designation	 Benennung	 Descripción
0	06227200	ADESIVO "CONTROLLARE LIVELLO OLIO MOTORE " 7 LINGUE GIALLO L=82X108 (**)	DECAL	AUTOCOLLANT	AUFKLEBER	PEGATINA
0	06232100	ADESIVO	STICKER	AUTOCOLLANT	AUFKLEBER	PEGATINA
0	06254800	ADESIVO" STOP EMERGENZA" SFONDO GIALLO L=100X50 (**)	DECAL	AUTOCOLLANT	AUFKLEBER	PEGATINA
0	06448100	ADESIVO	STICKER	AUTOCOLLANT	AUFKLEBER	PEGATINA
0	06448200	ADESIVO	STICKER	AUTOCOLLANT	AUFKLEBER	PEGATINA
0	06506400	ADESIVO	STICKER	AUTOCOLLANT	AUFKLEBER	PEGATINA
0	06520600	ADESIVO	STICKER	AUTOCOLLANT	AUFKLEBER	PEGATINA
0	06555500	ADESIVO	STICKER	AUTOCOLLANT	AUFKLEBER	PEGATINA
0	06555600	ADESIVO	STICKER	AUTOCOLLANT	AUFKLEBER	PEGATINA
0	06555700	ADESIVO	STICKER	AUTOCOLLANT	AUFKLEBER	PEGATINA
0	06555800	ADESIVO	STICKER	AUTOCOLLANT	AUFKLEBER	PEGATINA
0	06561200	ADESIVO	STICKER	AUTOCOLLANT	AUFKLEBER	PEGATINA
0	06594500	ADESIVO	STICKER	AUTOCOLLANT	AUFKLEBER	PEGATINA
0	06706500	ADESIVO	STICKER	AUTOCOLLANT	AUFKLEBER	PEGATINA
0	06840400	ADESIVO	STICKER	AUTOCOLLANT	AUFKLEBER	PEGATINA
0	06922700	ADESIVO	STICKER	AUTOCOLLANT	AUFKLEBER	PEGATINA
0	06924300	ADESIVO	STICKER	AUTOCOLLANT	AUFKLEBER	PEGATINA
0	06998800	ADESIVO	STICKER	AUTOCOLLANT	AUFKLEBER	PEGATINA
0	07034200	ADESIVO	STICKER	AUTOCOLLANT	AUFKLEBER	PEGATINA
0	07050700	ADESIVO	STICKER	AUTOCOLLANT	AUFKLEBER	PEGATINA
0	07056300	ADESIVO	STICKER	AUTOCOLLANT	AUFKLEBER	PEGATINA
0	07056400	ADESIVO	STICKER	AUTOCOLLANT	AUFKLEBER	PEGATINA
0	07056700	ADESIVO	STICKER	AUTOCOLLANT	AUFKLEBER	PEGATINA
0	07056800	ADESIVO	STICKER	AUTOCOLLANT	AUFKLEBER	PEGATINA
0	07058800	ADESIVO	STICKER	AUTOCOLLANT	AUFKLEBER	PEGATINA
0	07060500	ADESIVO	STICKER	AUTOCOLLANT	AUFKLEBER	PEGATINA



Main color codes:  J1 - JLG Cream,  J2 - JLG Orange,  C4 - Green



 ADESIVI
 STICKER
 AUTOCOLLANT

AUFKLEBER 
 PEGATINA 



POS	Codice	 Descrizione	 Description	 Designation	 Benennung	 Descripción
0	07060600	ADESIVO	STICKER	AUTOCOLLANT	AUFKLEBER	PEGATINA
0	07060700	ADESIVO	STICKER	AUTOCOLLANT	AUFKLEBER	PEGATINA
0	07071000	ADESIVO	STICKER	AUTOCOLLANT	AUFKLEBER	PEGATINA
0	07071200	ADESIVO	STICKER	AUTOCOLLANT	AUFKLEBER	PEGATINA
0	07194400	ADESIVO	DECAL	AUTOCOLLANT	AUFKLEBER	PEGATINA
0	07199100	ADESIVO	STICKER	AUTOCOLLANT	AUFKLEBER	PEGATINA
0	07240300	ADESIVO	STICKER	AUTOCOLLANT	AUFKLEBER	PEGATINA
0	07242000	ADESIVO	STICKER	AUTOCOLLANT	AUFKLEBER	PEGATINA
0	07264700	ADESIVO INDICATORE LED CARICABATTERIE 48V (Ø EST.31MM Ø INT.6 MM) VECCHIO BMS (FINO A C170000329)	DECAL	AUTOCOLLANT	AUFKLEBER	PEGATINA
0	07264800	ADESIVO	DECAL	AUTOCOLLANT	AUFKLEBER	PEGATINA
0	07268300	ADESIVO	DECAL	AUTOCOLLANT	AUFKLEBER	PEGATINA
0	07320400	ADESIVO	STICKER	AUTOCOLLANT	AUFKLEBER	PEGATINA
0	07349200	ADESIVO	DECAL	AUTOCOLLANT	AUFKLEBER	PEGATINA
0	07350300	ADESIVO	DECAL	AUTOCOLLANT	AUFKLEBER	PEGATINA
0	07394800	ADESIVO INDICATORE LED CARICABATTERIE 48V (Ø EST.31MM Ø INT.6 MM) NUOVO BMS/4 (DA C170000330)	DECAL	AUTOCOLLANT	AUFKLEBER	PEGATINA
0	07396900	ADESIVO	DECAL	AUTOCOLLANT	AUFKLEBER	PEGATINA
0	07397200	ADESIVO	DECAL	AUTOCOLLANT	AUFKLEBER	PEGATINA
0	07499300	ADESIVO DON'T OPEN THE CASE SFONDO GIALLO L=60X17 MM	DECAL	AUTOCOLLANT	AUFKLEBER	PEGATINA
0	07506500	ADESIVO JLG - EMERGENCY STOP L= 170X100 MM	DECAL	AUTOCOLLANT	AUFKLEBER	PEGATINA



Main color codes:  J1 - JLG Cream,  J2 - JLG Orange,  C4 - Green



 ADESIVI
 STICKER
 AUTOCOLLANT





AUFKLEBER 
 PEGATINA 



POS	Codice	 Descrizione	 Description	 Designation	 Benennung	 Descripción
0	07508200	ADESIVO BLOCCHETTO ACCENSIONE MOTORE DIESEL - EST. Ø70 - INT. Ø 35 MM	DECAL	AUTOCOLLANT	AUFKLEBER	PEGATINA
0	07512700	ADESIVO ATTENZIONE! NON COLLEGARE IL COMPUTER L=75X75 MM	STICKER	AUTOCOLLANT	AUFKLEBER	PEGATINA
0	07526800	ADESIVO REAZIONE AL SUOLO STABILIZZATORI X600AJ L= 50X50 - BIANCO	DECAL	AUTOCOLLANT	AUFKLEBER	PEGATINA
0	07668000	ADESIVO PERICOLO 110 VOLT 32A GIALLO	DECAL	AUTOCOLLANT	AUFKLEBER	PEGATINA
0	07668100	ADESIVO PULSANTI DISTRIBUTORE PARTE AEREA LL2614 L=318X52 MM	DECAL	AUTOCOLLANT	AUFKLEBER	PEGATINA
0	07668200	ADESIVO EMERGENCY STOP E BLOCCHETTO ACCENSIONE L=85X160 MM	DECAL	AUTOCOLLANT	AUFKLEBER	PEGATINA
0	07668300	ADESIVO	DECAL	AUTOCOLLANT	AUFKLEBER	PEGATINA
0	07669000	ADESIVO	DECAL	AUTOCOLLANT	AUFKLEBER	PEGATINA
0	07669100	ADESIVO	DECAL	AUTOCOLLANT	AUFKLEBER	PEGATINA
0	07690100	ADESIVO	DECAL	AUTOCOLLANT	AUFKLEBER	PEGATINA
0	07691500	ADESIVO	DECAL	AUTOCOLLANT	AUFKLEBER	PEGATINA
0	07802200	ADESIVO RUMORE 102 DB L=90X100 MM	STICKER NOISE 102 DB L = 90 X 100 MM	AUTOCOLLANT	AUFKLEBER	PEGATINA



Main color codes:  J1 - JLG Cream,  J2 - JLG Orange,  C4 - Green



 ADESIVI
 STICKER
 AUTOCOLLANT





AUFKLEBER 
 PEGATINA 



POS	Codice	 Descrizione	 Description	 Designation	 Benennung	 Descripción
0	07846700	ADESIVO	DECAL	AUTOCOLLANT	AUFKLEBER	PEGATINA
0	07878400	ADESIVO CASCO IMBRAGATURA E DIVIETI LL1370 L=175X118 MM	STICKER HELMET HARNESS AND BANS	AUTOCOLLANT CASQUE HARNAIS ET INTERDICTION	STICKER HELMGURT UND VERBOTE	ETIQUETA ARNÉS CASCO Y PROHIBICIONES
0	08069800	ADESIVO	STICKER	AUTOCOLLANT	AUFKLEBER	PEGATINA
0	080760GB	ADESIVO	STICKER	AUTOCOLLANT	AUFKLEBER	PEGATINA
0	08141300	ADESIVO	DECAL	AUTOCOLLANT	AUFKLEBER	PEGATINA
0	08318500	ADESIVO	DECAL	AUTOCOLLANT	AUFKLEBER	PEGATINA
0	08347400	STRISCIA BIANCA E ROSSA	DECAL	AUTOCOLLANT	AUFKLEBER	PEGATINA
0	08347500	STRISCIA BIANCA E ROSSA	DECAL	AUTOCOLLANT	AUFKLEBER	PEGATINA
0	1001125483	ADESIVO	STICKER	AUTOCOLLANT	AUFKLEBER	PEGATINA
0	1001223055	ADESIVO ISPEZIONE ANNUALE	DECAL YEARLY INSPECTION	INSPECTION ANNUELLE DES DÉCALQUES	AUFKLEBER JAHRESKONTROLLE	INSPECCIÓN ANUAL DE LA CALCOMANÍA
0	1001223453	ADESIVO NORMATIVA CANADESE ICES-002	CANADIAN REGULATIONS DECAL ICES-002	AUTOCOLLANT RÉGLEMENTAIRE CANADIEN ICES-002	KANADISCHE VORSCHRIFT AUFKLEBER	PEGATINA REGULATORIO CANADIENSE
0	1001228370	ADESIVO NORMATIVA CANADESE ICES-001	CANADIAN REGULATIONS DECAL ICES-001	AUTOCOLLANT RÉGLEMENTAIRE CANADIEN ICES-001	KANADISCHE VORSCHRIFTEN AUFKLEBER ICES-001	PEGATINA REGULATORIO CANADIENSE ICES- 001
0	1608710001	ADESIVO	STICKER	AUTOCOLLANT	AUFKLEBER	PEGATINA
0	1608710002	ADESIVO	STICKER	AUTOCOLLANT	AUFKLEBER	PEGATINA
0	1701499	ADESIVO	STICKER	AUTOCOLLANT	AUFKLEBER	PEGATINA
0	1701504	ADESIVO	STICKER	AUTOCOLLANT	AUFKLEBER	PEGATINA
0	1701505	ADESIVO	STICKER	AUTOCOLLANT	AUFKLEBER	PEGATINA
0	1701542	ADESIVO	STICKER	AUTOCOLLANT	AUFKLEBER	PEGATINA
0	1701640	ADESIVO	STICKER	AUTOCOLLANT	AUFKLEBER	PEGATINA
0	1701644	ADESIVO JLG CAVO CARICABATTERIA	STICKER JLG CABLE CHARGER	AUTOCOLLANT	AUFKLEBER	PEGATINA
0	1702155	ADESIVO	STICKER	AUTOCOLLANT	AUFKLEBER	PEGATINA

Main color codes:  J1 - JLG Cream,  J2 - JLG Orange,  C4 - Green

 ADESIVI
 STICKER
 AUTOCOLLANT

AUFKLEBER 
 PEGATINA 

POS	Codice	 Descrizione	 Description	 Designation	 Benennung	 Descripció
0	1703813	ADESIVO	STICKER	AUTOCOLLANT	AUFKLEBER	PEGATINA
0	1703814	ADESIVO	STICKER	AUTOCOLLANT	AUFKLEBER	PEGATINA
0	1704125	ADESIVO	DECAL	AUTOCOLLANT	AUFKLEBER	PEGATINA
0	1704277	ADESIVO	STICKER	AUTOCOLLANT	AUFKLEBER	PEGATINA
0	1705828	ADESIVO	STICKER	AUTOCOLLANT	AUFKLEBER	PEGATINA
0	1706098	ADESIVO	STICKER	AUTOCOLLANT	AUFKLEBER	PEGATINA
0	1706385	ADESIVO	STICKER	AUTOCOLLANT	AUFKLEBER	PEGATINA
0	1706493	ADESIVO	STICKER	AUTOCOLLANT	AUFKLEBER	PEGATINA
0	1706898	ADESIVO	STICKER	AUTOCOLLANT	AUFKLEBER	PEGATINA
0	1848760001	ADESIVO PER MACCHINE CON OLIO BIODEGRADABILE	STICKER FOR MACHINES WITH OIL BIODEGRADABLE	AUTOCOLLANT	AUFKLEBER	PEGATINA



Main color codes:  J1 - JLG Cream,  J2 - JLG Orange,  C4 - Green



OPTIONAL



POS	Codice	 Descrizione	 Description	 Designation	 Benennung	 Descripció
0	17890500	KIT RIPRISTINO IMPIANTO FUNI SU 20 METRI	CABLES KIT	KIT CÂBLES	KABELSATZ	KIT CABLES

Main color codes:  **J1** - JLG Cream,  **J2** - JLG Orange,  **C4** - Green

Cod. 17107300

KIT INTEGRAZIONE ADESIVI PER PIATTAFORME AEREE LITHIUM-ANSI
INTEGRATION KIT STICKERS PLATFORMS LITHIUM-ANSI

X370AJ • X390AJ • X430AJ • X500AJ • X550AJ • X600AJ • X700AJ • X770AJ

Da usare in aggiunta ai seguenti kit di sicurezza /
To use in addition to the following safety kit

X370AJcod.17788300
X390AJcod.17065200
X430AJ.....cod.17788300
X500AJ / MK2.....cod. 17776800
X550AJ.....cod. 17065300
X600AJ / MK2.....cod. 17777000
X700AJ.....cod. 17065400
X770AJ.....cod. 17633600

+ kit in lingua non inclusi nel codice generale / language code not included in the standard kit

+171073GB + 171073FR + 171073ES + 171073PT

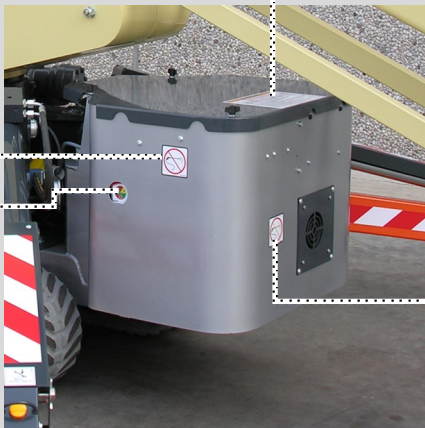

KIT ADESIVI - X390AJ

SET OF DECALS - X390AJ

KIT COLLANTS - X390AJ

AUFKLEBERSATZ - X390AJ

KIT ADHESIVOS - X390AJ

ADHESIEKIT - X390AJ

cod. 17107300

Tav 01

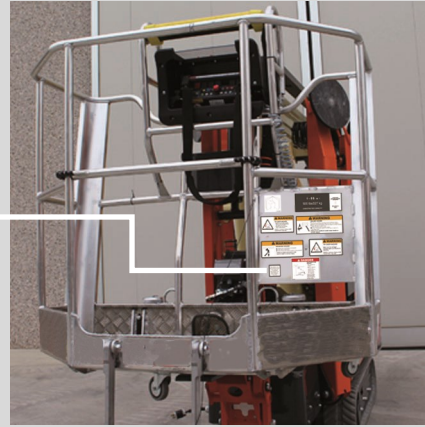
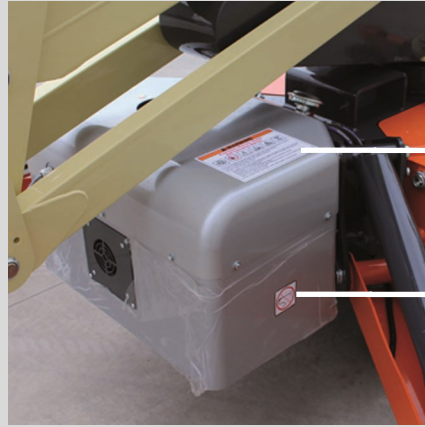
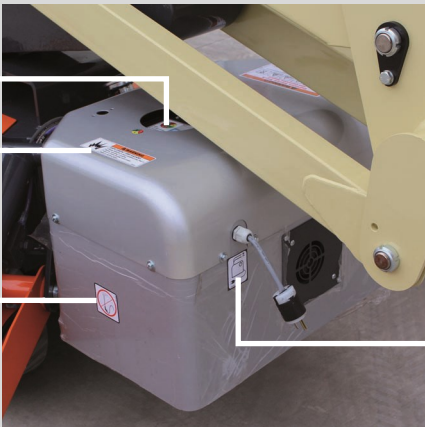
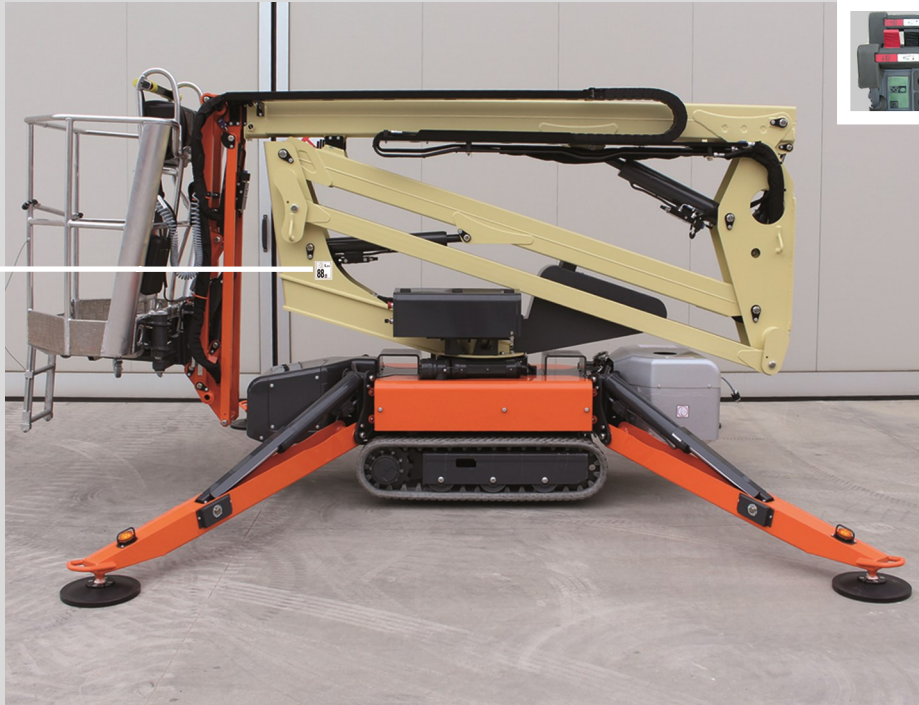

KIT ADESIVI - X370AJ / X430AJ

SET OF DECALS - X370AJ / X430AJ

KIT COLLANTS - X370AJ / X430AJ

AUFKLEBERSATZ - X370AJ / X430AJ

KIT ADHESIVOS - X370AJ / X430AJ

ADHESIEKIT - X370AJ / X430AJ

cod. 17107300

Tav 01



11



3

3

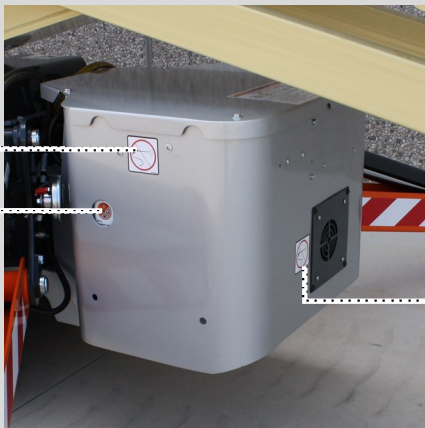

1

4

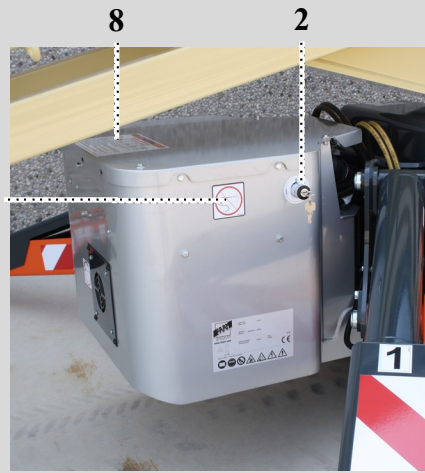

8

2

1

1

1

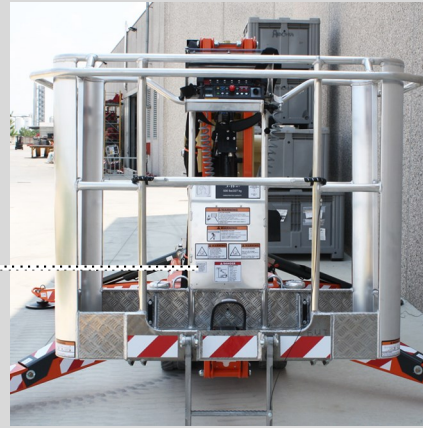

9

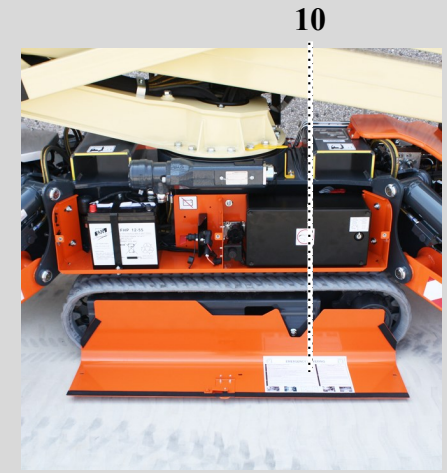

10

KIT ADESIVI - X500AJ

SET OF DECALS - X500AJ

KIT COLLANTS - X500AJ

AUFKLEBERSATZ - X500AJ

KIT ADHESIVOS - X500AJ

ADHESIEKIT - X500AJ

cod. 17107300

Tav 01



Sotto il coperchio /
under the cover



KIT ADESIVI - X600AJ

SET OF DECALS - X600AJ

KIT COLLANTS - X600AJ

AUFKLEBERSATZ - X600AJ

KIT ADHESIVOS - X600AJ

ADHESIEKIT - X600AJ

cod. 17107300

Tav 01



11

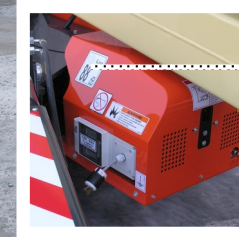

Sotto il coperchio /
under the cover

3

3



8



2

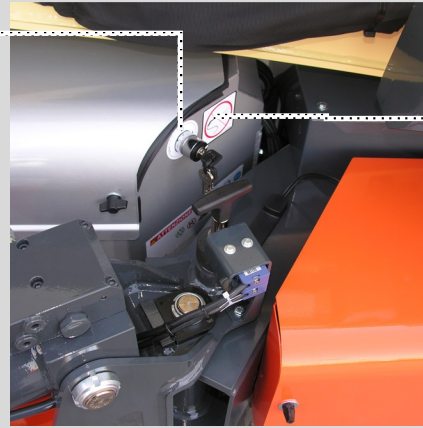

1

9

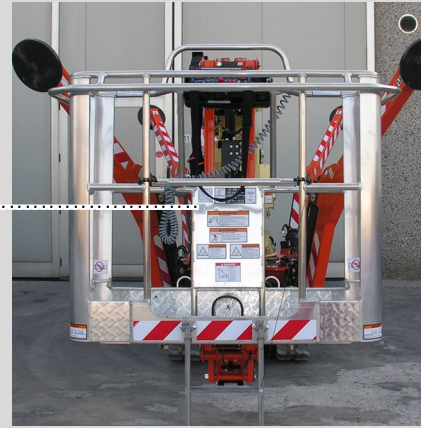

5 5 1

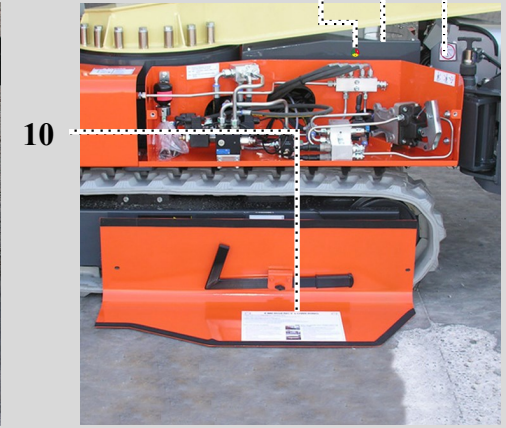

10

KIT ADESIVI - X700AJ

SET OF DECALS - X700AJ

KIT COLLANTS - X700AJ

AUFKLEBERSATZ - X700AJ

KIT ADHESIVOS - X700AJ

ADHESIEKIT - X700AJ

cod. 17107300

Tav 01



Sotto il coperchio /
under the cover

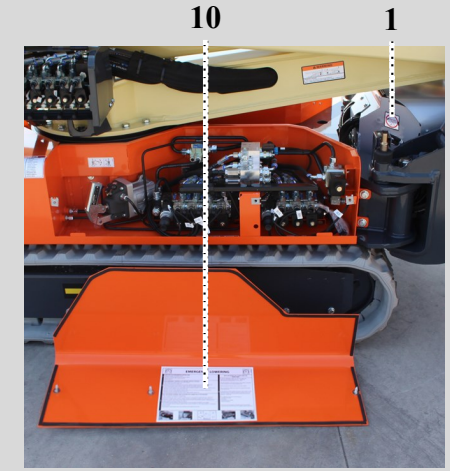
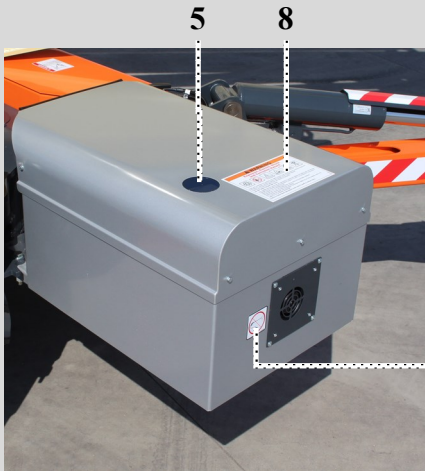

KIT ADESIVI - X770AJ

SET OF DECALS - X770AJ

KIT COLLANTS - X770AJ

AUFKLEBERSATZ - X770AJ

KIT ADHESIVOS - X770AJ

ADHESIEKIT - X770AJ

cod. 17107300

Tav 01

POS.	COD.	DESCRIZIONE / DESCRIPTION	Q.tà
01	1001125483	ADESIVO JLG VIETATO LAVARE L=63,5X63,5 MM	03
02	06506400	ADESIVO " CHIAVE DI ACCENSIONE" ESTERNO Ø 49 FORO Ø 22 SERIE LITHIUM ION _MOD_B (**)	01
03	06520600	ADESIVO RUMORE 88 dB L=90x100 MM _MOD_B (**)	02
04	07264700	ADESIVO INDICATORE LED CARICABATTERIE 48V (Ø EST.31MM Ø INT.6 MM) VECCHIO BMS (FINO A C170000329)	01
	07394800	ADESIVO INDICATORE LED CARICABATTERIE 48V (Ø EST.31MM Ø INT.6 MM) NUOVO BMS/4 (DA C170000330)	01
05	07264800	ADESIVO INDICATORE LED RICARICA BATTERIE Ø EST.21MM Ø INT.4 MM	02
06	1701644	ADESIVO JLG CAVO CARICABATTERIA L: 50,8X63,5 MM	01
07	1703813	ADESIVO JLG PERICOLO ESPLOSIONE BATTERIE - ING L=149,25X47,62 MM	01
08			
09			
10			
11	07194400	ADESIVO BOLLINO PER TELECOMANDO SERE IIIS COLORE GRIGIO Ø 10,50 MM	03
12			
13			
14			
15			
16			
17			
18			
19			
20			
21			

Cod. 17187700

KIT INTEGRAZIONE ADESIVI PER PIATTAFORME AEREE LITHIUM-CE /
INTEGRATION KIT STICKERS PLATFORMS LITHIUM-CE

X14J - X17J - X19J - X23J

X13JPLUS - X15JPLUS - X17JPLUS - X20JPLUS - X26JPLUS

Da usare in aggiunta a / To use in added to

X14J - cod.17063500

X14J-H - cod.17065000

X17J cod.17063700

X19J cod.17063200

X23J cod.17062700

X13JPLUS cod. 17788100

X15JPLUS cod. 17788100

X17JPLUS cod. 17242800

X20JPLUS cod. 17351800

X26JPLUS cod. 17633400

+ kit in lingua non inclusi nel codice generale + language code not included in the standard kit

171877IT / 171877GB / 171877FR / 171877DE / 171877ES / 171877NL / 171877SW / 171877PT /
171877DA / 171877NO / 171877RU / 171877PL / 171877SL / 171877FI / 171877CE / 171877JA



KIT ADESIVI X14J LITHIUM

SET OF DECALS X14J LITHIUM

KIT COLLANTS X14J LITHIUM

AUFKLEBERSATZ X14J LITHIUM

KIT ADHESIVOS X14J LITHIUM

ADHESIEKIT X14J LITHIUM

cod. 17187700

Tav 01



9



8



1

4

3

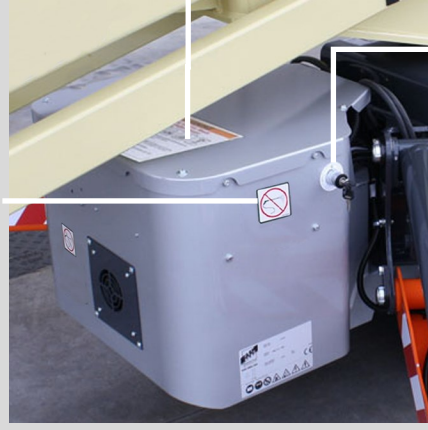

6

1

1

2

7



3

KIT ADESIVI X17J LITHIUM

SET OF DECALS X17J LITHIUM

KIT COLLANTS X17J LITHIUM

AUFKLEBERSATZ X17J LITHIUM

KIT ADHESIVOS X17J LITHIUM

ADHESIEKIT X17J LITHIUM

cod. 17187700

Tav 01



9

3

3

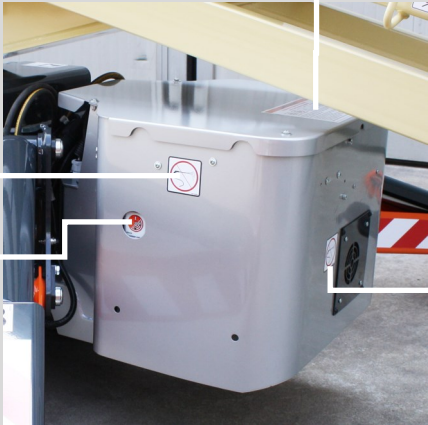

2

1

1

4

1

6

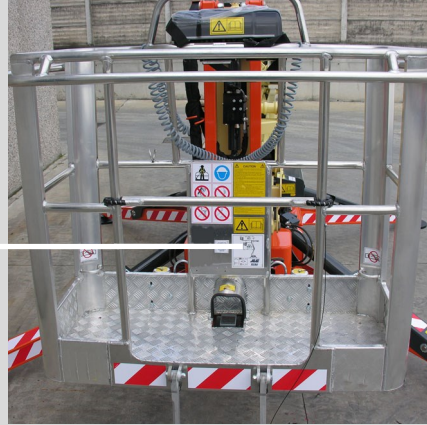

7



8

KIT ADESIVI X19J LITHIUM

SET OF DECALS X19J LITHIUM

KIT COLLANTS X19J LITHIUM

AUFKLEBERSATZ X19J LITHIUM

KIT ADHESIVOS X19J LITHIUM

ADHESIEKIT X19J LITHIUM

cod. 17187700

Tav 01

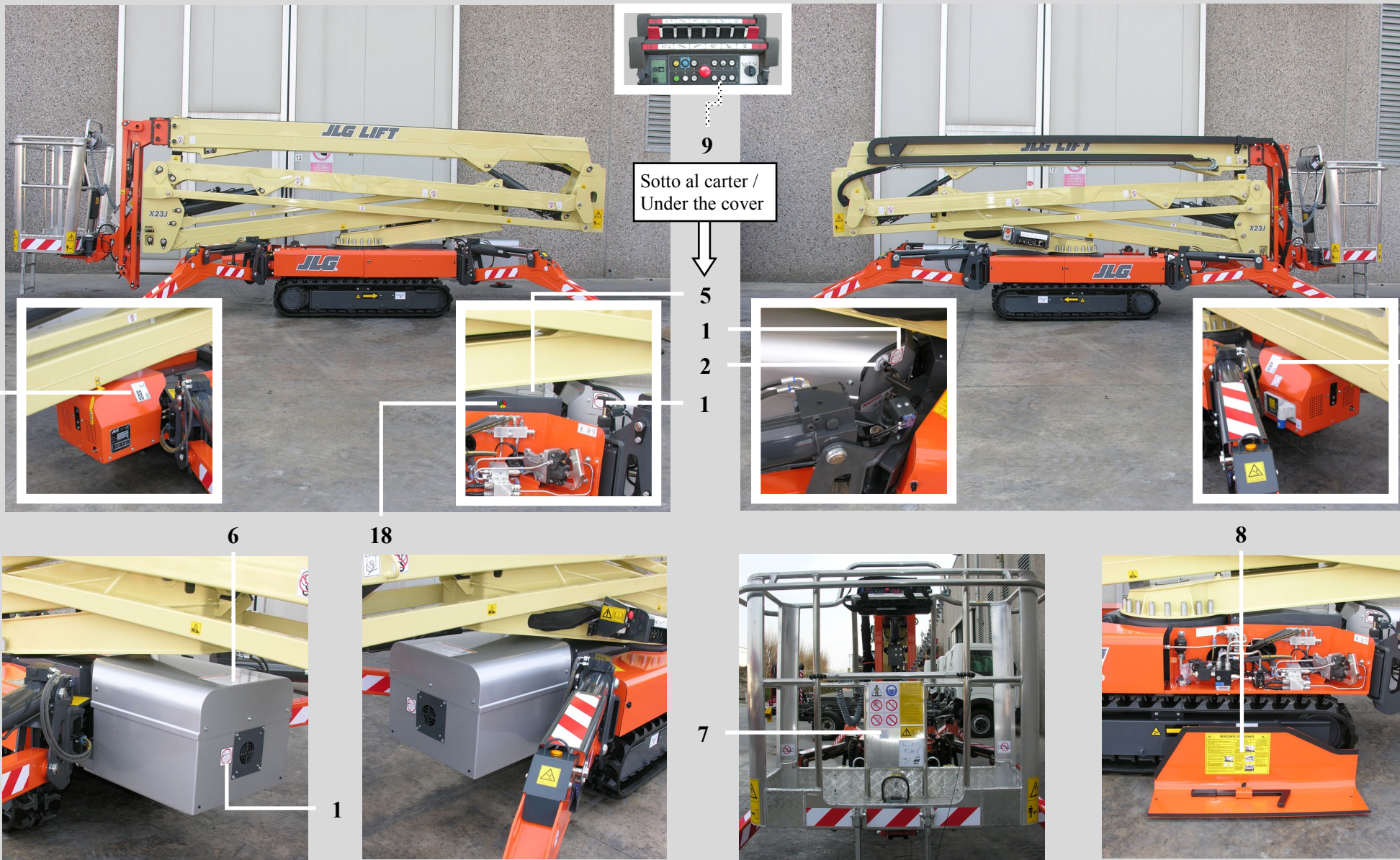

KIT ADESIVI X23J LITHIUM

SET OF DECALS X23J LITHIUM

KIT COLLANTS X23J LITHIUM

AUFKLEBERSATZ X23J LITHIUM

KIT ADHESIVOS X23J LITHIUM

ADHESIEKIT X23J LITHIUM

cod. 17187700

Tav 01



9



3

3



4

1



1

6

7

1



8

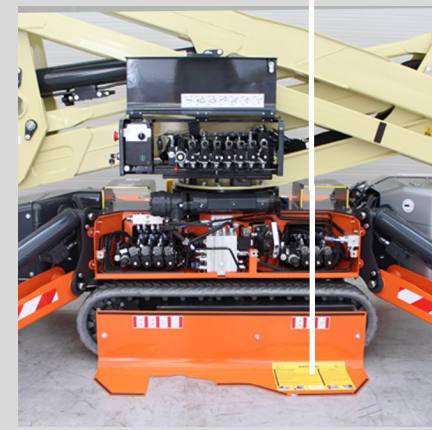

KIT ADESIVI - X13JPLUS LITHIUM
 SET OF DECALS - X13JPLUS LITHIUM
 KIT COLLANTS - X13JPLUS LITHIUM

AUFKLEBERSATZ X - X13JPLUS LITHIUM
 KIT ADHESIVOS - X13JPLUS LITHIUM
 ADHESIEKIT - X13JPLUS LITHIUM

cod. 17187700

Tav 01

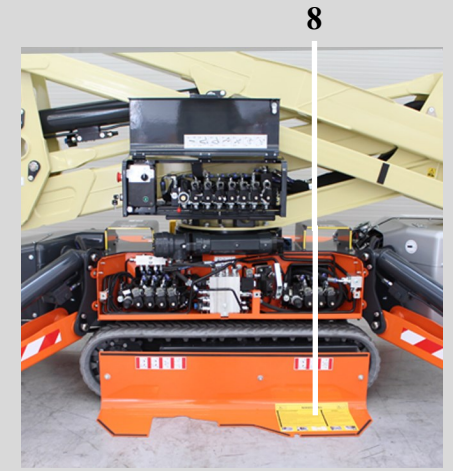

KIT ADESIVI - X15JPLUS LITHIUM
 SET OF DECALS - X15JPLUS LITHIUM
 KIT COLLANTS - X15JPLUS LITHIUM

AUFKLEBERSATZ X - X15JPLUS LITHIUM
 KIT ADHESIVOS - X15JPLUS LITHIUM
 ADHESIEKIT - X15JPLUS LITHIUM

cod. 17187700

Tav 01



9

3

3

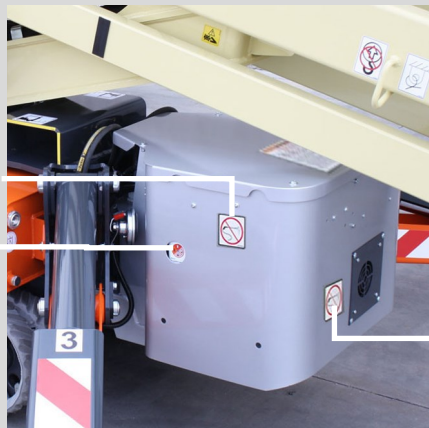

1

4

3



1

6

7

1



8



KIT ADESIVI X17JPLUS LITHIUM

SET OF DECALS X17JPLUS LITHIUM

KIT COLLANTS X17JPLUS LITHIUM

AUFKLEBERSATZ X17JPLUS LITHIUM

KIT ADHESIVOS X17JPLUS LITHIUM

ADHESIEKIT X17JPLUS LITHIUM

cod. 17187700

Tav 01



9



3

6



1

5

1



2

1

7



8



KIT ADESIVI X20JPLUS LITHIUM

SET OF DECALS X20JPLUS LITHIUM

KIT COLLANTS X20JPLUS LITHIUM

AUFKLEBERSATZ X20JPLUS LITHIUM

KIT ADHESIVOS X20JPLUS LITHIUM

ADHESIEKIT X20JPLUS LITHIUM

cod. 17187700

Tav 01

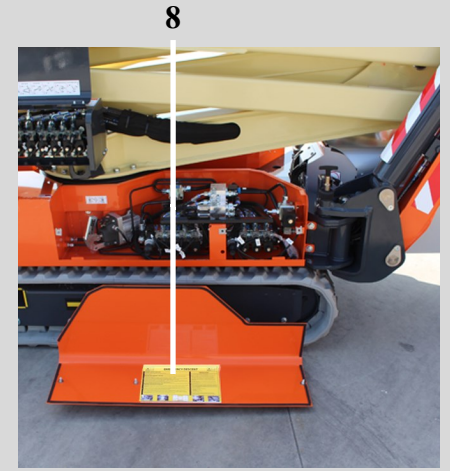
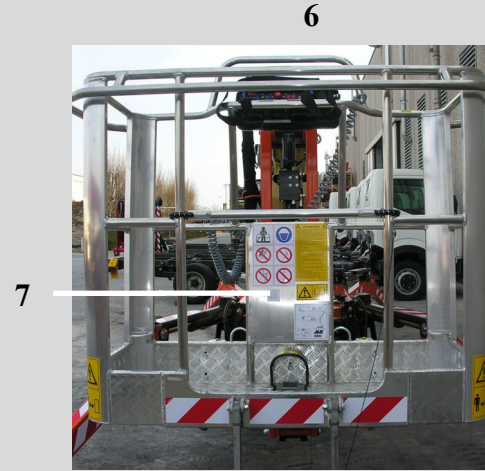
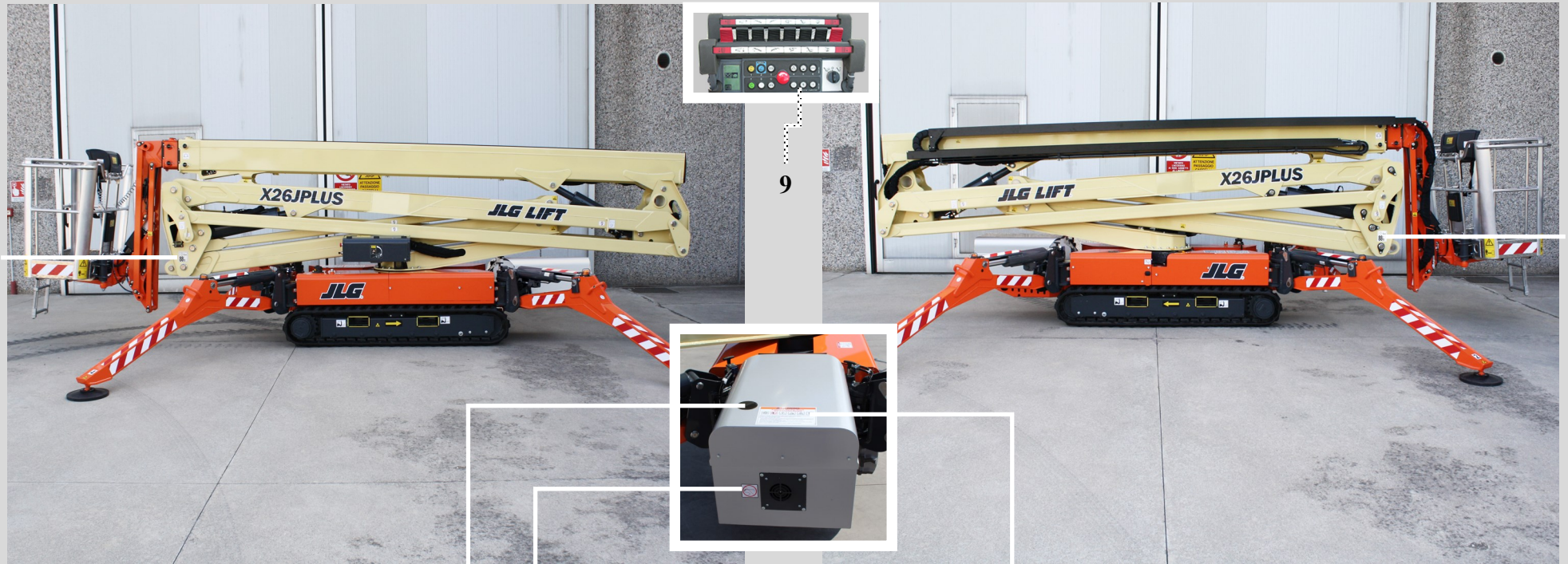

KIT ADESIVI X26JPLUS LITHIUM

SET OF DECALS X26JPLUS LITHIUM

KIT COLLANTS X26JPLUS LITHIUM

AUFKLEBERSATZ X26JPLUS LITHIUM

KIT ADHESIVOS X26JPLUS LITHIUM

ADHESIEKIT X26JPLUS LITHIUM

cod. 17187700

Tav 01

KIT LITHIUM SERIE JLG/CE COD. 171877 POSIZIONE ADESIVI IN LINGUA / POSITION LANGUAGE STICKERS**

POS.	COD.	REV.	DESCRIZIONE / DESCRIPTION	Q.tà
	171877IT		KIT ADESIVI INTEGRAZIONE PIATTAFORME AEREE JLG/CE LITHIUM - LINGUA ITALIANO	
06	07188700	A	ADESIVO JLG ATTENZIONE PERICOLO BATTERIE - ITA L=210X145 MM	01
07	07188100	A	ADESIVO JLG RICARICARE LE BATTERIE DOPO L'USO O ALMENO OGNI 3 MESI L=50x50 MM – ITA	01
08 solo X17J	1705720001	A	ADESIVO ISTRUZIONI DISCESA DI EMERGENZA GL14703S LITHIUM ITALIANO L=290X175 MM (**)	01
08			Per le / for X14J-X19J-X23J • X13JP-X15JP-X17JP-X20JP-X26JP Vedere discesa di emergenza motore termico / See emergency lowering heat engine	
	171877GB		KIT ADESIVI INTEGRAZIONE PIATTAFORME AEREE JLG/CE LITHIUM - LINGUA INGLESE	
06	07201700	A	ADESIVO JLG ATTENZIONE PERICOLO BATTERIE - ING L=210X145 MM	01
07	07202100	A	ADESIVO JLG-CE RICARICARE LE BATTERIE DOPO L'USO ALMENO OGNI 3 MESI - ING L=50x50 MM	01
08 per X17J	1705720002	A	ADESIVO ISTRUZIONI DISCESA DI EMERGENZA GL14703S LITHIUM INGLESE L=290X175 MM	01
08			Per le / for X14J-X19J-X23J • X13JP-X15JP-X17JP-X20JP-X26JP Vedere discesa di emergenza motore termico / See emergency lowering heat engine	
	171877FR		KIT ADESIVI INTEGRAZIONE PIATTAFORME AEREE JLG/CE LITHIUM - LINGUA FRANCESE	
06	07201800	A	ADESIVO JLG ADESIVO ATTENZIONE PERICOLO BATTERIE - FRA L=210X145 MM	01
07	07202200	A	ADESIVO JLG RICARICARE LE BATTERIE DOPO L'USO ALMENO OGNI 3 MESI - FRA L=50x50 MM	01
08 per X17J	1705720003	A	ADESIVO ISTRUZIONI DISCESA DI EMERGENZA GL14703S LITHIUM FRANCESE L=290X175 MM (**)	01
08			Per le / for X14J-X19J-X23J • X13JP-X15JP-X17JP-X20JP-X26JP Vedere discesa di emergenza motore termico / See emergency lowering heat engine	

KIT LITHIUM SERIE JLG/CE COD. 171877 POSIZIONE ADESIVI IN LINGUA / POSITION LANGUAGE STICKERS**

POS.	COD.	REV.	DESCRIZIONE / DESCRIPTION	Q.tà
	171877DE		KIT ADESIVI INTEGRAZIONE PIATTAFORME AEREE JLG/CE LITHIUM - LINGUA TEDESCO	
06	07188800	A	ADESIVO JLG ATTENZIONE PERICOLO BATTERIE - TED L=210X145 MM	01
07	07188200	A	ADESIVO JLG RICARICARE LE BATTERIE DOPO L'USO O ALMENO OGNI 3 MESI L=50x50 MM –TED	01
08 per X17J	1705720004	A	ADESIVO ISTRUZIONI DISCESA DI EMERGENZA GL14703S LITHIUM TEDESCO L=290X175 MM (**)	01
08	Per le / for X14J-X19J-X23J • X13JP-X15JP-X17JP-X20JP-X26JP Vedere discesa di emergenza motore termico / See emergency lowering heat engine			
	171877ES		KIT ADESIVI INTEGRAZIONE PIATTAFORME AEREE JLG/CE LITHIUM - LINGUA SPAGNOLO	
06	07201900	A	ADESIVO JLG ATTENZIONE PERICOLO BATTERIE - SPA L=210X145 MM -	01
07	07202300	A	ADESIVO JLG RICARICARE LE BATTERIE DOPO L'USO ALMENO OGNI 3 MESI - SPA L=50x50 MM	01
08 per X17J	1705720005	A	ADESIVO ISTRUZIONI DISCESA DI EMERGENZA GL14703S LITHIUM SPAGNOLO L=290X175 MM (**)	01
08	Per le / for X14J-X19J-X23J • X13JP-X15JP-X17JP-X20JP-X26JP Vedere discesa di emergenza motore termico / See emergency lowering heat engine			
	171877NL		KIT ADESIVI INTEGRAZIONE PIATTAFORME AEREE JLG/CE LITHIUM - LINGUA OLANDESE	
06	07188900	A	ADESIVO JLG ATTENZIONE PERICOLO BATTERIE - OLA L=210X145 MM	01
07	07188300	A	ADESIVO JLG RICARICARE LE BATTERIE DOPO L'USO O ALMENO OGNI 3 MESI L=50x50 MM – OLA	01
08 per X17J	1705720006	A	ADESIVO ISTRUZIONI DISCESA DI EMERGENZA GL14703S LITHIUM OLANDESE L=290X175 MM (**)	01
08	Per le / for X14J-X19J-X23J • X13JP-X15JP-X17JP-X20JP-X26JP Vedere discesa di emergenza motore termico / See emergency lowering heat engine			

KIT LITHIUM SERIE JLG/CE COD. 171877 POSIZIONE ADESIVI IN LINGUA / POSITION LANGUAGE STICKERS**

POS.	COD.	REV.	DESCRIZIONE / DESCRIPTION	Q.tà
	171877SW		KIT ADESIVI INTEGRAZIONE PIATTAFORME AEREE JLG/CE LITHIUM - LINGUA SVEDESE	
06	07189000	A	ADESIVO JLG ATTENZIONE PERICOLO BATTERIE - SVE L=210X145 MM	01
07	07188400	A	ADESIVO JLG RICARICARE LE BATTERIE DOPO L'USO O ALMENO OGNI 3 MESI L=50x50 MM – SVE	01
08 per X17J	1705720010	A	ADESIVO ISTRUZ. DISCESA DI EMERGENZA GL14703S LITHIUM SVEDESE L=290X175 MM (**)	01
08	Per le / for X14J-X19J-X23J • X13JP-X15JP-X17JP-X20JP-X26JP			
	Vedere discesa di emergenza motore termico / See emergency lowering heat engine			
	171877PT		KIT ADESIVI INTEGRAZIONE PIATTAFORME AEREE JLG/CE LITHIUM - LINGUA PORTOGHESE	
06	07202000	A	ADESIVO JLG ATTENZIONE PERICOLO BATTERIE - POR L=210X145 MM	01
07	07202400	A	ADESIVO JLG RICARICARE LE BATTERIE DOPO L'USO O ALMENO OGNI 3 MESI L=50x50 MM – POR	01
08 per X17J	1705720007	A	ADESIVO ISTRUZ. DISCESA DI EMERGENZA GL14703S LITHIUM PORTOGHESE L=290X175 MM (**)	01
08	Per le / for X14J-X19J-X23J • X13JP-X15JP-X17JP-X20JP-X26JP			
	Vedere discesa di emergenza motore termico / See emergency lowering heat engine			
	171877DA		KIT ADESIVI INTEGRAZIONE PIATTAFORME AEREE JLG/CE LITHIUM - LINGUA DANESE	
06	07189100	A	ADESIVO JLG ATTENZIONE PERICOLO BATTERIE - DAN L=210X145 MM	01
07	07188500	A	ADESIVO JLG RICARICARE LE BATTERIE DOPO L'USO O ALMENO OGNI 3 MESI L=50x50 MM – DAN	01
08 per X17J	1705720011	A	ADESIVO ISTRUZ. DISCESA DI EMERGENZA GL14703S LITHIUM DANESE L=290X175 MM (**)	01
08	Per le / for X14J-X19J-X23J • X13JP-X15JP-X17JP-X20JP-X26JP			
	Vedere discesa di emergenza motore termico / See emergency lowering heat engine			

KIT LITHIUM SERIE JLG/CE COD. 171877 POSIZIONE ADESIVI IN LINGUA / POSITION LANGUAGE STICKERS**

POS.	COD.	REV.	DESCRIZIONE / DESCRIPTION	Q.tà
	171877NO		KIT ADESIVI INTEGRAZIONE PIATTAFORME AEREE JLG/CE LITHIUM - LINGUA NORVEGESE	
06	07189200	A	ADESIVO JLG ATTENZIONE PERICOLO BATTERIE - NOR L=210X145 MM	01
07	07188600	A	ADESIVO JLG RICARICARE LE BATTERIE DOPO L'USO O ALMENO OGNI 3 MESI L=50x50 MM – NOR	01
08 per X17J	1705720012	A	ADESIVO ISTRUZ. DISCESA DI EMERGENZA GL14703S LITHIUM NORVEGESE L=290X175 MM (**)	01
08	Per le / for X14J - X17JPLUS - X19J - X20JPLUS - X23J - X26JPLUS Vedere discesa di emergenza motore termico / See emergency lowering heat engine			
	171877RU		KIT ADESIVI INTEGRAZIONE PIATTAFORME AEREE JLG/CE LITHIUM - LINGUA RUSSO	
06	07920800	A	ADESIVO JLG ATTENZIONE PERICOLO BATTERIE - RUSSO L=210X145 MM	01
07	07910300	A	ADESIVO JLG RICARICARE LE BATTERIE DOPO L'USO O ALMENO OGNI 3 MESI L=50x50 MM – RUS	01
08 per X17J	/		/	/
08	Per le / for X14J - X17JPLUS - X19J - X20JPLUS - X23J - X26JPLUS Vedere discesa di emergenza motore termico / See emergency lowering heat engine			
	171877PL		KIT ADESIVI INTEGRAZIONE PIATTAFORME AEREE JLG/CE LITHIUM - LINGUA POLACCO	
06	07508000	A	ADESIVO JLG-ANSI ATTENZIONE PERICOLO BATTERIE - POLACCO L=210X145 MM	01
07	07508100	A	ADESIVO JLG-CE RICARICARE LE BATTERIE DOPO L'USO - POLACCO L=50x50 MM	01
08 per X17J	/		/	/
08	Per le / for X14J - X17JPLUS - X19J - X20JPLUS - X23J - X26JPLUS Vedere discesa di emergenza motore termico / See emergency lowering heat engine			

KIT LITHIUM SERIE JLG/CE COD. 171877 POSIZIONE ADESIVI IN LINGUA / POSITION LANGUAGE STICKERS**

POS.	COD.	REV.	DESCRIZIONE / DESCRIPTION	Q.tà
	171877SL		KIT ADESIVI INTEGRAZIONE PIATTAFORME AEREE JLG/CE LITHIUM - LINGUA SLOVENO	
06	07920900	A	ADESIVO JLG / CE ATTENZIONE PERICOLO BATTERIE - SLOVENO L=210X145 MM	01
07	07910500	A	ADESIVO JLG RICARICARE LE BATTERIE DOPO L'USO O ALMENO OGNI 3 MESI L=50x50 MM – SLO	01
08 per X17J	/	/	/	/
08	Per le / for X14J - X17JPLUS - X19J - X20JPLUS - X23J - X26JPLUS Vedere discesa di emergenza motore termico / See emergency lowering heat engine			
	171877FI		KIT ADESIVI INTEGRAZIONE PIATTAFORME AEREE JLG/CE LITHIUM - LINGUA FINLANDESE	
06	07921000	A	ADESIVO JLG / CE ATTENZIONE PERICOLO BATTERIE - FINLANDESE L=210X145 MM	01
07	07910600	A	ADESIVO JLG RICAR. LE BATTERIE DOPO L'USO O ALMENO OGNI 3 MESI L=50x50 MM – FINLANDE	01
08 per X17J	/	/	/	/
08	Per le / for X14J - X17JPLUS - X19J - X20JPLUS - X23J - X26JPLUS Vedere discesa di emergenza motore termico / See emergency lowering heat engine			
	171877CE		KIT ADESIVI INTEGRAZIONE PIATTAFORME AEREE JLG/CE LITHIUM - LINGUA CECO	
06	07921100	A	ADESIVO JLG-CE ATTENZIONE PERICOLO BATTERIE - CECO L=210X145 MM	01
07	07910700	A	ADESIVO JLG-CE RICARICARE LE BATTERIE DOPO L'USO ALMENO OGNI 3 MESI - JAPAN L=50x50 MM	01
08 per X17J	/		/	/
08	Per le / for X14J - X17JPLUS - X19J - X20JPLUS - X23J - X26JPLUS Vedere discesa di emergenza motore termico / See emergency lowering heat engine			
	171877JA		KIT ADESIVI INTEGRAZIONE PIATTAFORME AEREE JLG/CE LITHIUM - LINGUA GIAPPONESE	
06	07341100	A	ADESIVO JLG - CE ATTENZIONE PERICOLO BATTERIE - JAPAN L=210X145 MM	01
07	07341200	A	ADESIVO JLG-CE RICARICARE LE BATTERIE DOPO L'USO - JAPAN L=50x50 MM	01
08 per X17J	/		/	/
08	Per le / for X14J - X17JPLUS - X19J - X20JPLUS - X23J - X26JPLUS Vedere discesa di emergenza motore termico / See emergency lowering heat engine			

AGGIORNATO IL / UPDATED 26/10/2015

Cod. 17351800

**KIT ADESIVI SICUREZZA PIATTAFORMA AEREA /
AERIAL PLATFORM KIT STICKERS SAFETY
JLG - CE / X20JPLUS**

+ **kit in lingua non inclusi nel codice generale** + *language code not included in the standard kit*

**173518IT / 173518GB / 173518FR / 173518DE / 173518ES / 173518NL /
173518PT / 173518DA / 173518NO / 173518SW / 173518FI**

DA USARE CON / FOR USE WITH

- **17351900** KIT ADESIVI COMMERCIALI PIATTAFORMA AEREA / *STICKER KITS COMMERCIAL AERIAL PLATFORM X20JPLUS*
- **17187700** KIT INTEGRAZIONE ADESIVI PIATTAFORME 3S LITHIUM /*STICKER KIT INTEGRATION PLATFORM LITHIUM X14J_14J-H_X17J_X17JPLUS_X20JPLUS_X19J_X23J*

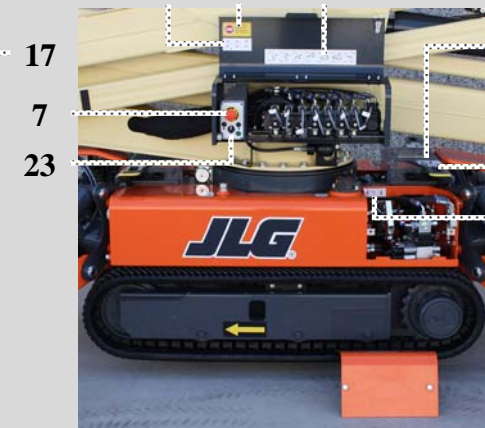
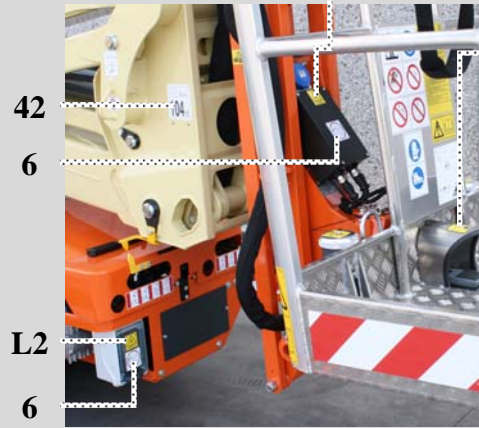
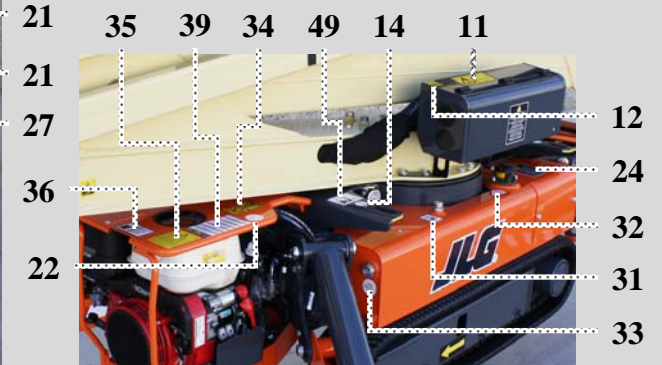
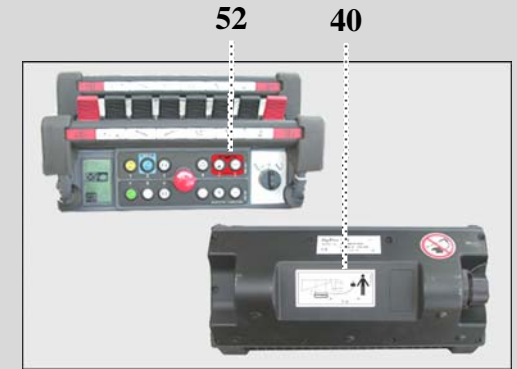
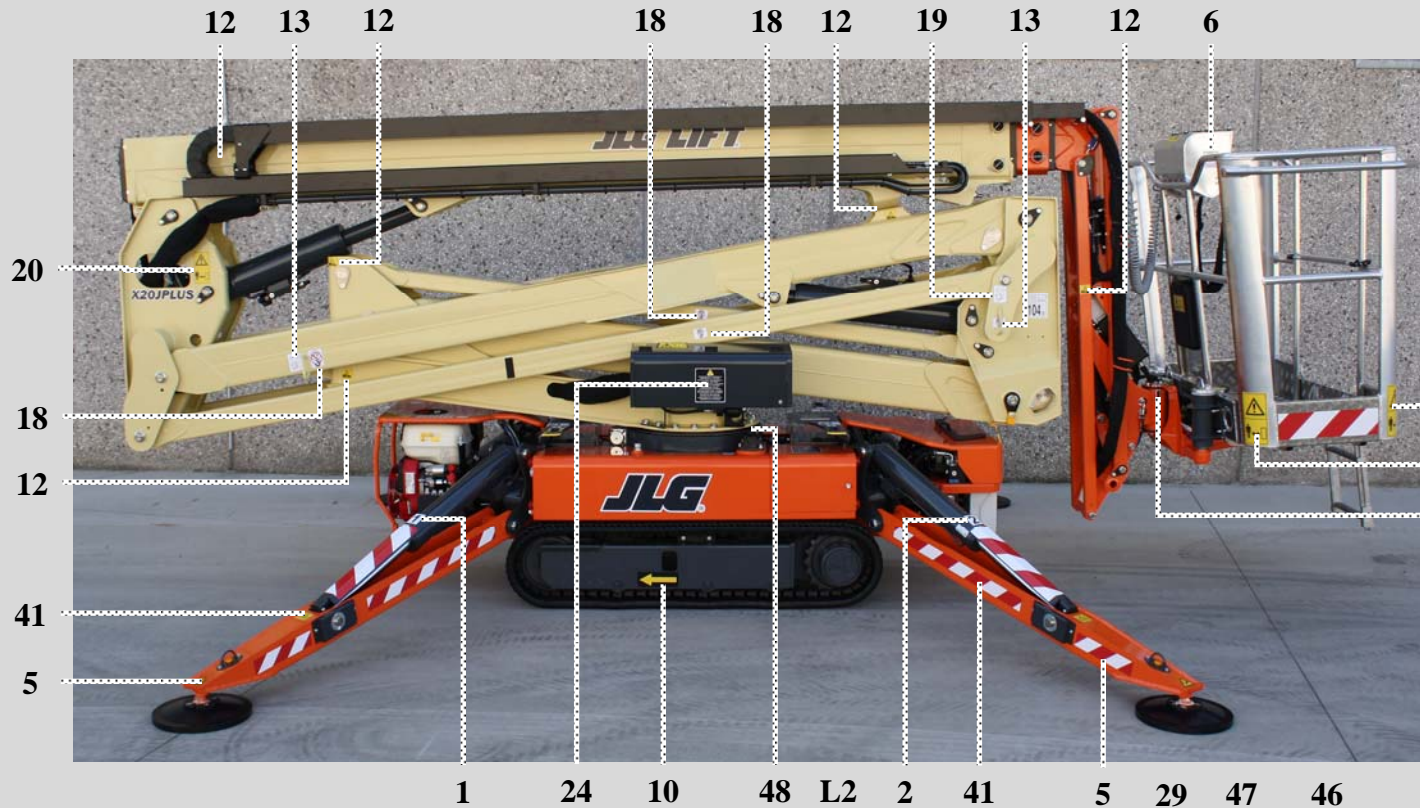

KIT ADESIVI - X20JPLUS	AUFKLEBERSATZ - X20JPLUS	cod. 17351800
SET OF DECALS - X20JPLUS	KIT ADHESIVOS - X20JPLUS	
KIT COLLANTS - X20JPLUS	ADHESIEKIT - X20JPLUS	Tav 01

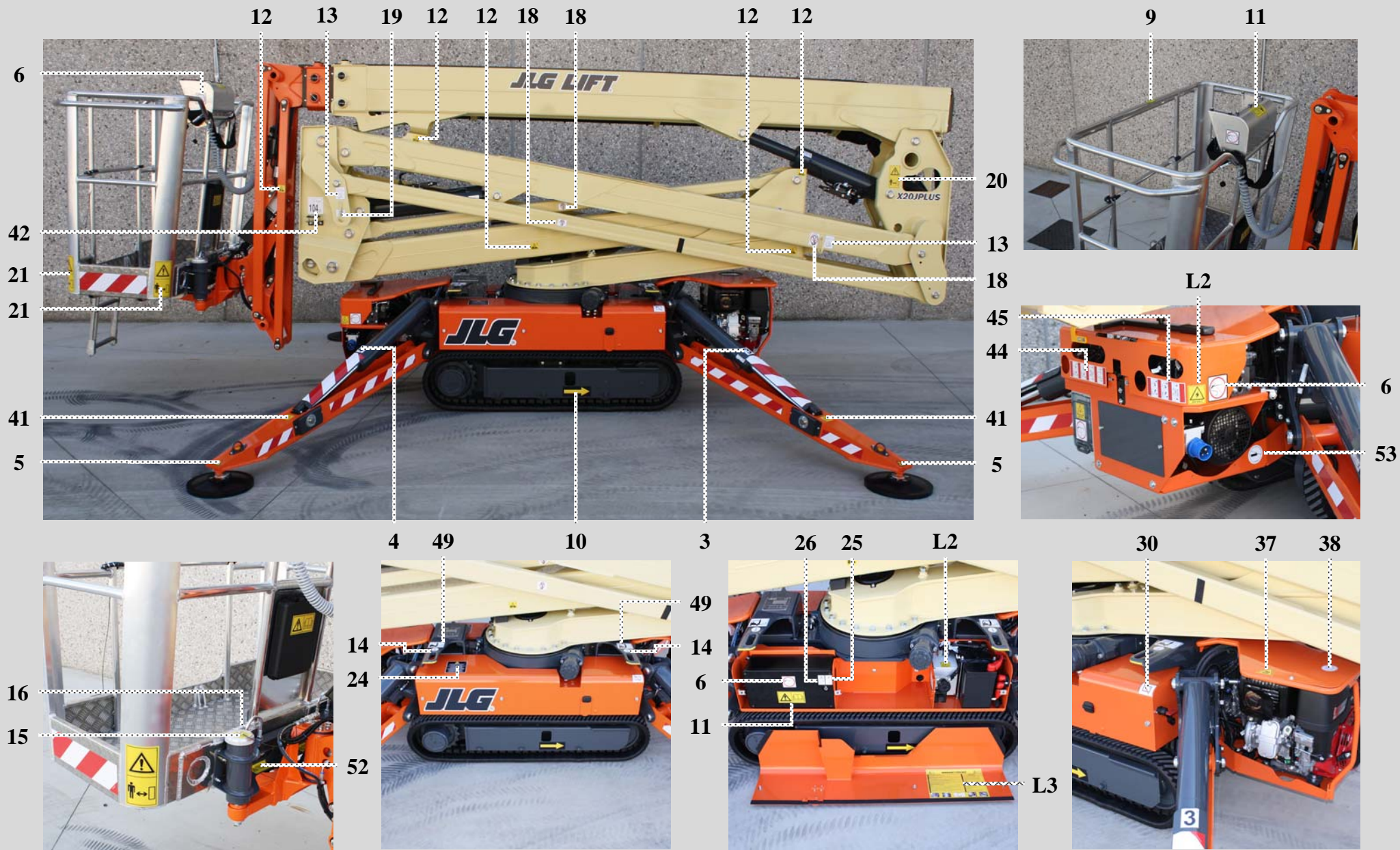

KIT ADESIVI - X20JPLUS

SET OF DECALS - X20JPLUS

KIT COLLANTS - X20JPLUS

AUFKLEBERSATZ - X20JPLUS

KIT ADHESIVOS - X20JPLUS

ADHESIEKIT - X20JPLUS

cod. 17351800

Tav 02

MOTORE DIESEL / DIESEL ENGINE



38 50 54 11



22 34 35 37

KIT ADESIVI - X20JPLUS

SET OF DECALS - - X20JPLUS

KIT COLLANTS - - X20JPLUS

AUFKLEBERSATZ - - X20JPLUS

KIT ADHESIVOS - - X20JPLUS

ADHESIEKIT - - X20JPLUS

cod. 17351800

Tav 03

Cod. 17351800

KIT ADESIVI SICUREZZA PIATTAFORMA AEREA /
AERIAL PLATFORM KIT STICKERS SAFETY

JLG - CE / X20JPLUS

X20JPLUS COD. 17351800 POSIZIONE ADESIVI / POSITION ADHESIVE

JLG

POS.	COD.	REV.	DESCRIZIONE / DESCRIPTION	Q.tà
01	06555500	A	ADESIVO NR 1 L=50X60 BIANCO	01
02	06555600	A	ADESIVO NR 2 L=50X60 BIANCO	01
03	06555700	A	ADESIVO N° 3 L=50X60 BIANCO	01
04	06555800	A	ADESIVO N° 4 L=50X60 BIANCO	01
05	06041200	A	ADESIVO SCHIACCIAMENTO PIEDI TRIANGOLARE L=53X46 GIALLO	04
06	1001125483	A	ADESIVO JLG VIETATO LAVARE L=63,5X63,5 MM (**)	06
07	1706898	A	ADESIVO JLG EMERGENCY STOP Ø EST.57,15 Ø INT. 30,58 (**)	01
08	06924300	A	ADESIVO CASCO - IMBRAGATURA - DIVIETI SERIE METAL-IIIS L= 170X250 MM	01
09	1706493	B	ADESIVO JLG SCORRIMENTO SBARRA CHIUSURA CESTO L= 76,2X25,4 MM (**)	01
10	06040500	A	ADESIVO DIREZ. TRASLAZIONE FRECCIA GIALLA SFONDO NERO L=61 X 160	02
11	06040900	A	ADESIVO LEGGERE IL MANUALE L=125 X 65 GIALLO	06
12	06041300	B	ADESIVO ATTENZIONE PERICOLO TAGLI L=35 X 40 GIALLO	11
13	1703814	A	ADESIVO JLG ATTACCO ANCORAGGIO L=55,56X76,2 MM (**)	04
14	06044000	A	ADESIVO ATTACCO SOLLEVAMENTO SFONDO BIANCO COLORE BLU Ø40 (**)	04
15	06448200	B	ADESIVO "SBLOCCARE SOLO NEI CASI PREVISTI" Ø 60 MM	02
16	1704277	A	ADESIVO JLG ATTACCO CINTURE DI SICUREZZA L= 76,2X19,05 MM	02
17	1705828	B	ADESIVO JLG INTERUTTORE PEDALE L= 69,85X54 (**)	01
18	07056700	A	ADESIVO JLG DIVIETO DI SOLLEVAMENTO L=54,88X40 (**)	06
19	1701499	A	ADESIVO JLG DIVIETO DI SOLLEVAMENTO DAL PUNTO DI ANCORAGGIO L= 55,56X76 MM (**)	02
20	07058800	A	ADESIVO PERICOLO MANTENERE LE DISTANZE L=65X130 MM	02
21	06040300	A	ADESIVO PERICOLO MANTENERE LE DISTANZE GIALLO L=100 X 200 MM (**)	04
22	1706098	B	ADESIVO JLG PERICOLO ESPLOSIONE L=63,5X117,475 MM (**)	01
23	07349200	A	ADESIVO AVVIAMENTO MOTORE DA TERRA LL2010 IIIS L=76,5X37 MM	01
24	07056800	B	ADESIVO JLG DISCESA DI EMERGENZA ALL'INTERNO L=114X130 MM (**)	03

X20JPLUS COD. 17351800 POSIZIONE ADESIVI / POSITION ADHESIVE

JLG

POS.	COD.	REV.	DESCRIZIONE / DESCRIPTION	Q.tà
25	06086000	A	ADESIVO SISTEMA BYPASS TRASLAZIONE L=30X50	01
26	06085900	A	ADESIVO SISTEMA BYPASS PARTE AEREA L=30X50	01
27	06706500	A	ADESIVO ALLINEAMENTO CESTO (2 PEZZI) L=16X50+13	01
28	06998800	A	ADESIVO DEVIATORE POMPA MANUALE PIATTAFORMA GL17.80XL L=86X34	01
29	07242000	A	ADESIVO SELETTORE 3 POSIZIONI 2° TELECOMANDO	01
30	1702155	A	ADESIVO JLG STACCABATTERIA L= 63,5X50,80 MM (**)	01
31	1701504	A	ADESIVO JLG OLIO IDRAULICO L=50,8x63,5 MM (**)	01
32	06164700	A	ADESIVO FILTRO OLIO Ø50 SFONDO BIANCO	01
33	06165000	A	ADESIVO LIVELLO OLIO IDRAULICO Ø50 SFONDO BIANCO	01
34	06060000	A	ADESIVO LIVELLO OLIO MOTORE Ø50mm	01
35	06227200	B	ADESIVO CONTROLLARE LIVELLO OLIO GIALLO L= 80x80 MM	01
36	06041600	B	ADESIVO CARBURANTE BENZINA COLORE VERDE L=60 X 80 MM	01
36	1701505	A	ADESIVO JLG CARBURANTE DIESEL L= 50,8X63,5 (**)	01
37	06056300	A	ADESIVO PERICOLO SCOTTATURE L=60X51 TRIANGOLARE SFONDO GIALLO	01
38	06164600	A	ADESIVO FILTRO ARIA Ø50 SFONDO BIANCO	01
39	06232100	B	ADESIVO ATTENZIONE BENZINA INFIAMMABILE L= 170X42 MM	01
40	07240300	B	ADESIVO DISTANZA 1m SU TELE/RADIO COMANDI	01
41	07320400	A	ADESIVO REAZIONE AL SUOLO STABILIZZATORI LL2010	04
42	07034200	B	ADESIVO RUMORE 104 dB L=90X100	02
43	07397200	A	ADESIVO JLG X20JPLUS PORTATA CESTO 2 PERSONE L=135X145 MM	01
44	1608710001	C	ADESIVO PULSANTI DISTR. A TERRA LATO SX GL17.80 L=194X50 MM	01
45	1608710002	C	ADESIVO PULSANTI DISTRIB A TERRA GL 17.80 LATO DX L= 150X50 mm	01
46	07199100	A	ADESIVO COMANDI AEREI DA TERRA LL1775	01
47	06254800	B	ADESIVO STOP EMERGENZA SFONDO GIALLO L=70X50 (**)	01

X20JPLUS COD. 17351800 POSIZIONE ADESIVI / POSITION ADHESIVE**JLG**

POS.	COD.	REV.	DESCRIZIONE / DESCRIPTION	Q.tà
48	06922700	A	ADESIVO FRECCIA ALLINEAMENTO L=50x15 (**)	02
49	07350300	A	ADESIVO SOLLEVAMENTO PIATTAFORMA CON MULETTO L=90X70 MM	04
50	06214200	A	ADESIVO LIQUIDO REFRIGERANTE SFONDO BIANCO Ø 50	01
51	06448100	B	ADESIVO RIPRISTINARE I TAPPI FERMO GUIDA L= 100X35 MM	02
52	07071000	B	ADESIVO JLG CLAXON SU PIATTAFORME L=38,3X28,55 MM (**)	01
53	06136900	A	ADESIVO PUNTI DI INGRASSAGGIO Ø 55 mm	01
54	07508200	A	ADESIVO BLOCCHETTO ACCENSIONE MOTORE DIESEL - EST. Ø 70 - INT. Ø 35 MM	01
55				
56				
57				
58				
59				
60				
61				
62				
63				
64				
65				
66				
67				
68				
69				
70				
71	07669100	B	ADESIVO JLG X20JPLUS PORTATA CESTO 1 PERSONA L=135X145 MM - NON IN DISTINTA	01

KIT ADESIVI IN LINGUA / *LANGUAGE KIT STICKERS*
X20JPLUS - JLG

Cod. 173518IT

Cod. 173518GB

Cod. 173518FR

Cod. 173518DE

Cod. 173518ES

Cod. 173518NL

Cod. 173518PT

Cod. 173518SW

Cod. 173518DA

Cod. 173518NO

Cod. 173518FI

173518 POSIZIONE ADESIVI IN LINGUA /**
POSITION LANGUAGE STICKERS

IN LINGUA / LANGUAGE

VOLTAGGIO / VOLTAGE

POS.	COD.	REV.	DESCRIZIONE / DESCRIPTION	Q.tà
	1735181IT		ADESIVI PIATTAFORMA AEREA X20JPLUS LINGUA ITALIANO	
L1	06555300	B	ADESIVO USO PIATTAFORMA LINGUA ITALIANA LL 23.12 L=128X230 MM	01
L2	06561200	B	ADESIVO PERICOLO 230 VOLT 16A GIALLO L=47 X 47 MM	04
L3	07348900	A	ADESIVO DISCESA DI EMERGENZA LL 2010 MOTORE TERMICO E LITHIUM - ITA L=290X205 MM	01
	173518GB		ADESIVI PIATTAFORMA AEREA X20JPLUS LINGUA INGLESE	
L1	06562600	B	ADESIVO USO PIATTAFORMA INGLESE L=128X230 MM	01
L2	06561200	B	ADESIVO PERICOLO 230 VOLT 16A GIALLO L=47 X 47 MM	04
L3	073489GB	A	ADESIVO DISCESA DI EMERGENZA LL 2010 MOTORE TERMICO E LITHIUM - ING L=290X205 MM	01
	173518FR		ADESIVI PIATTAFORMA AEREA X20JPLUS LINGUA FRANCESE	
L1	06562700	B	ADESIVO USO PIATTAFORMA FRANCESE L=128X230 MM	01
L2	06561200	B	ADESIVO PERICOLO 230 VOLT 16A GIALLO L=47 X 47 MM	04
L3	073489FR	A	ADESIVO DISCESA DI EMERGENZA LL2010 MOTORE TERMICO E LITHIUM - FRA L=290X205 MM	01
	173518DE		ADESIVI PIATTAFORMA AEREA X20JPLUS LINGUA TEDESCO	
L1	06562800	B	ADESIVO USO PIATTAFORMA TEDESCO L=128X230 MM	01
L2	06561200	B	ADESIVO PERICOLO 230 VOLT 16A GIALLO L=47 X 47 MM	04
L3	073489DE	A	ADESIVO DISCESA DI EMERGENZA LL 2010 MOTORE TERMICO E LITHIUM - TED L=290X205 MM	01
	173518ES		ADESIVI PIATTAFORMA AEREA X20JPLUS LINGUA SPAGNOLO	
L1	06562900	B	ADESIVO USO PIATTAFORMA SPAGNOLO L=128X230 MM	01
L2	06561200	B	ADESIVO PERICOLO 230 VOLT 16A GIALLO L=47 X 47 MM	04
L3	073489ES	A	ADESIVO DISCESA DI EMERGENZA LL 2010 MOTORE TERMICO E LITHIUM - SPA L=290X205 MM	01

173518 POSIZIONE ADESIVI IN LINGUA /**
POSITION LANGUAGE STICKERS

IN LINGUA / LANGUAGE

VOLTAGGIO / VOLTAGE

POS.	COD.	REV.	DESCRIZIONE / DESCRIPTION	Q.tà
	173518NL		ADESIVI PIATTAFORMA AEREA X20JPLUS LINGUA OLANDESE	
L1	06563000	B	ADESIVO USO PIATTAFORMA OLANDESE L=128X230 MM	01
L2	06561200	B	ADESIVO PERICOLO 230 VOLT 16A GIALLO L=47 X 47 MM	04
L3	073489NL	A	ADESIVO DISCESA DI EMERGENZA LL 2010 MOTORE TERMICO E LITHIUM - OLA L=290X205 MM	01
	173518PT		ADESIVI PIATTAFORMA AEREA X20JPLUS LINGUA PORTOGHESE	
L1	06563100	B	ADESIVO USO PIATTAFORMA PORTOGHESE L=128X230 MM	01
L2	06561200	B	ADESIVO PERICOLO 230 VOLT 16A GIALLO L=47 X 47 MM	04
L3	073489PT	A	ADESIVO DISCESA DI EMERGENZA LL2010 MOTORE TERMICO E LITHIUM - POR L=290X205 MM	01
	173518SW		ADESIVI PIATTAFORMA AEREA X20JPLUS LINGUA SVEDESE	
L1	07137300	B	ADESIVO USO PIATTAFORMA AEREA CINGOLATA - SVEDESE L= 128X230 MM	01
L2	06561200	B	ADESIVO PERICOLO 230 VOLT 16A GIALLO L=47 X 47 MM	04
L3	073489SW	A	ADESIVO DISCESA DI EMERGENZA LL2010 MOTORE TERMICO E LITHIUM - SVE L=290X205 MM	01
	173518DA		ADESIVI PIATTAFORMA AEREA X20JPLUS LINGUA DANESE	
L1	07138100	B	ADESIVO USO PIATTAFORMA DANESE L=128X230 MM	01
L2	06561200	B	ADESIVO PERICOLO 230 VOLT 16A GIALLO L=47 X 47 MM	04
L3	073489DA	A	ADESIVO DISCESA DI EMERGENZA LL 2010 MOTORE TERMICO E LITHIUM - DAN L=290X205 MM	01
	173518NO		ADESIVI PIATTAFORMA AEREA X20JPLUS LINGUA NORVEGESE	
L1	07162000	B	ADESIVO USO PIATTAFORMA AEREA CINGOLATA - NORVEGESE L=128X230 MM	01
L2	06561200	B	ADESIVO PERICOLO 230 VOLT 16A GIALLO L=47 X 47 MM	04
L3	073489NO	A	ADESIVO DISCESA DI EMERGENZA .LL 2010 MOTORE TERMICO E LITHIUM - NOR L=290X205 MM	01

AGGIORNATO IL / UPDATED 06/04/2017

Cod. 17351900

**KIT ADESIVI COMMERCIALI PIATTAFORMA AEREA /
AERIAL PLATFORM KIT STICKERS COMMERCIAL
JLG/CE - X20JPLUS**

DA USARE CON / FOR USE WITH

**17776600 KIT ADESIVI DI SICUREZZA PIATTAFORMA AEREA JLG/CE X20JPLUS MK2 /
*STICKER KITS SAFETY AERIAL PLATFORM X20JPLUS MK2***

**17351800 KIT ADESIVI DI SICUREZZA PIATTAFORMA AEREA JLG/CE X20JPLUS /
*STICKER KITS SAFETY AERIAL PLATFORM X20JPLUS***

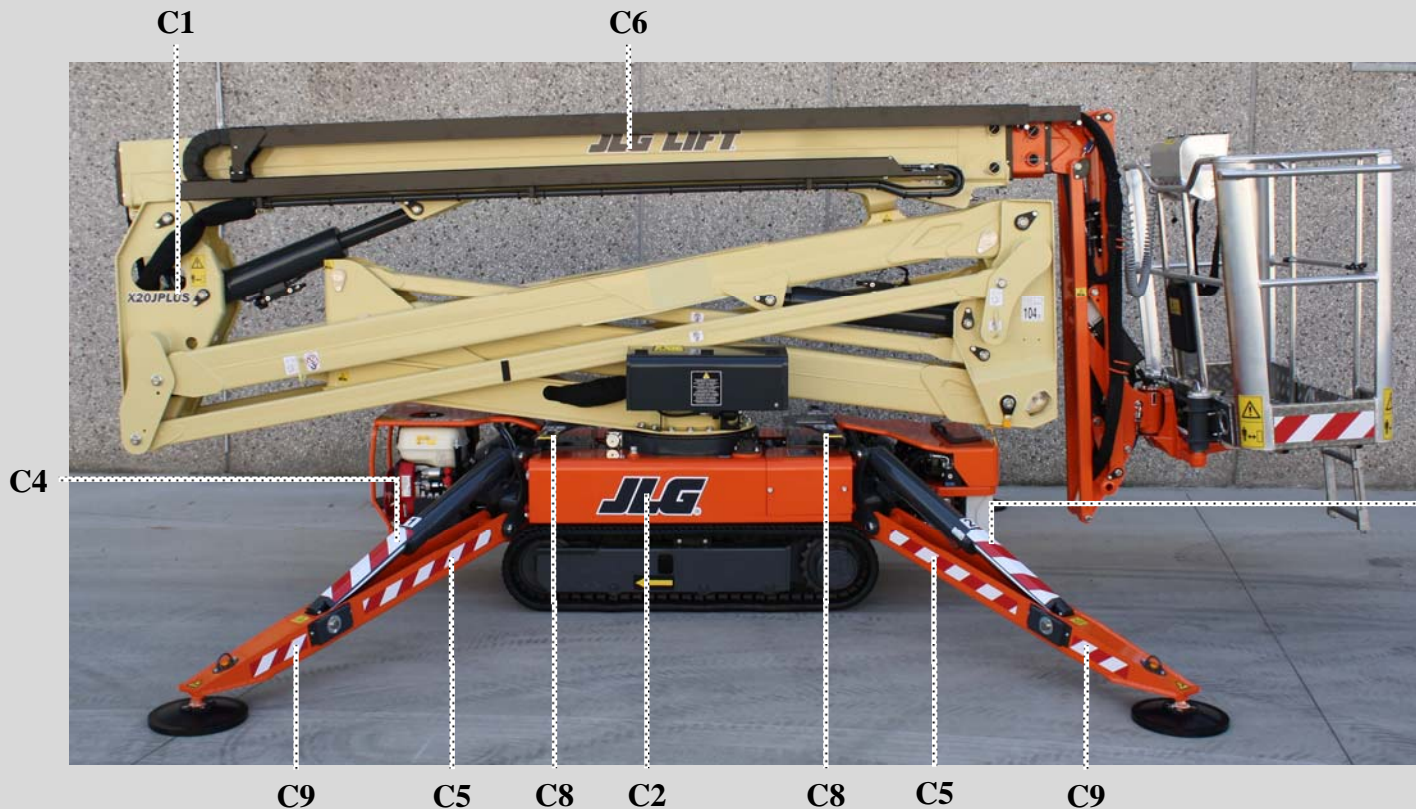

C10

KIT ADESIVI - X20JPLUS

SET OF DECALS - X20JPLUS

KIT COLLANTS - X20JPLUS

AUFKLEBERSATZ - X20JPLUS

KIT ADHESIVOS - X20JPLUS

ADHESIEKIT - X20JPLUS

cod. 17351900

Ed. 16/06/2015

Tav 01

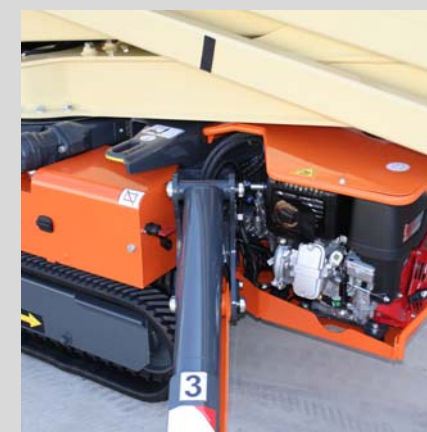
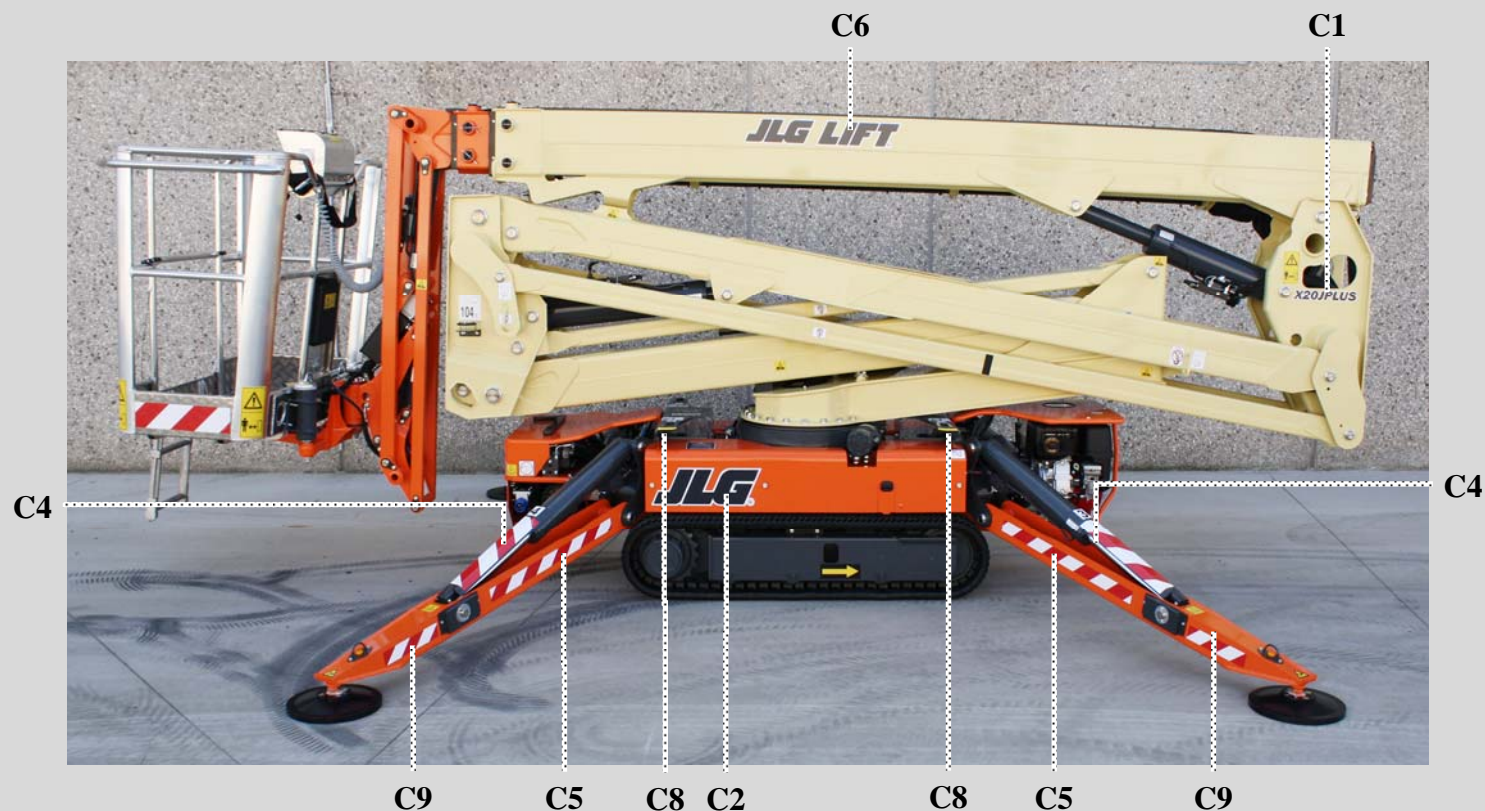

KIT ADESIVI - X20JPLUS

SET OF DECALS - X20JPLUS

KIT COLLANTS - X20JPLUS

AUFKLEBERSATZ - X20JPLUS

KIT ADHESIVOS - X20JPLUS

ADHESIEKIT - X20JPLUS

cod. 17351900

Ed. 16/06/2015

Tav 02

Cod. 17351900

**KIT ADESIVI COMMERCIALI PIATTAFORMA AEREA /
*AERIAL PLATFORM KIT STICKERS COMMERCIAL***

JLG/CE - X20JPLUS

17351900 POSIZIONE ADESIVI / POSITION ADHESIVE **Aggiornato il / Updated 16/06/2015**

JLG

POS.	COD.	REV.	DESCRIZIONE / DESCRIPTION	Q.tà
C1	07396900	A	ADESIVO JLG LOGO PIATTAFORMA AEREA CINGOLATA X20JPLUS L= 270X46 MM	02
C2	07060500	A	ADESIVO LOGO JLG L=432x150MM	02
C3				
C4	06086700	A	ADESIVO CON RIGHE BIANCHE E ROSSE L=430X100 (**)	06
C5	06039600	A	ADESIVO CON RIGHE BIANCHE ROSSE L= 700 X 50 (**)	08
C6	07060600	A	ADESIVO LOGO JLG LIFT L=624x100 MM	02
C7				
C8	07268300	A	ADESIVO ATTENZIONE SOLLEVAMENTO FORCHE L=80X7 MM	04
C9	06040100	A	ADESIVO CON RIGHE BIANCHE ROSSE L= 240 X 50 (**)	08
C10	06039700	A	ADESIVO CON RIGHE BIANCHE ROSSE L= 700 X 80	01
C11				
C12				
C13				
C14				
C15				
C16				
C17				
C18				
C19				
C20				
C21				
C22				
C23				
C24				

Cod. 17485000

KIT ADESIVI SICUREZZA PIATTAFORMA AEREA /
AERIAL PLATFORM KIT STICKERS SAFETY

JLG / ANSI - X600AJ

+ **Kit in lingua non inclusi nel codice generale**

+ *Language code not included in the standard kit*

174850GB

174850FR

174850ES

174850PT

DA USARE CON / FOR USE WITH

17485100 KIT ADESIVI COMMERCIALI PIATTAFORMA AEREA X600AJ ANSI /
STICKERS KIT COMMERCIAL AERIAL PLATFORM

17107300 KIT ADESIVI INTEGRAZIONE PER PIATTAFORME JLG-ANSI LITIUM /
STICKER KIT FOR INTEGRATION LITIUM PLATFORM

X390AJ - X500AJ - X550AJ - X600AJ - X700AJ - X770AJ

171073 KIT IN LINGUA / KIT IN LANGUAGE**

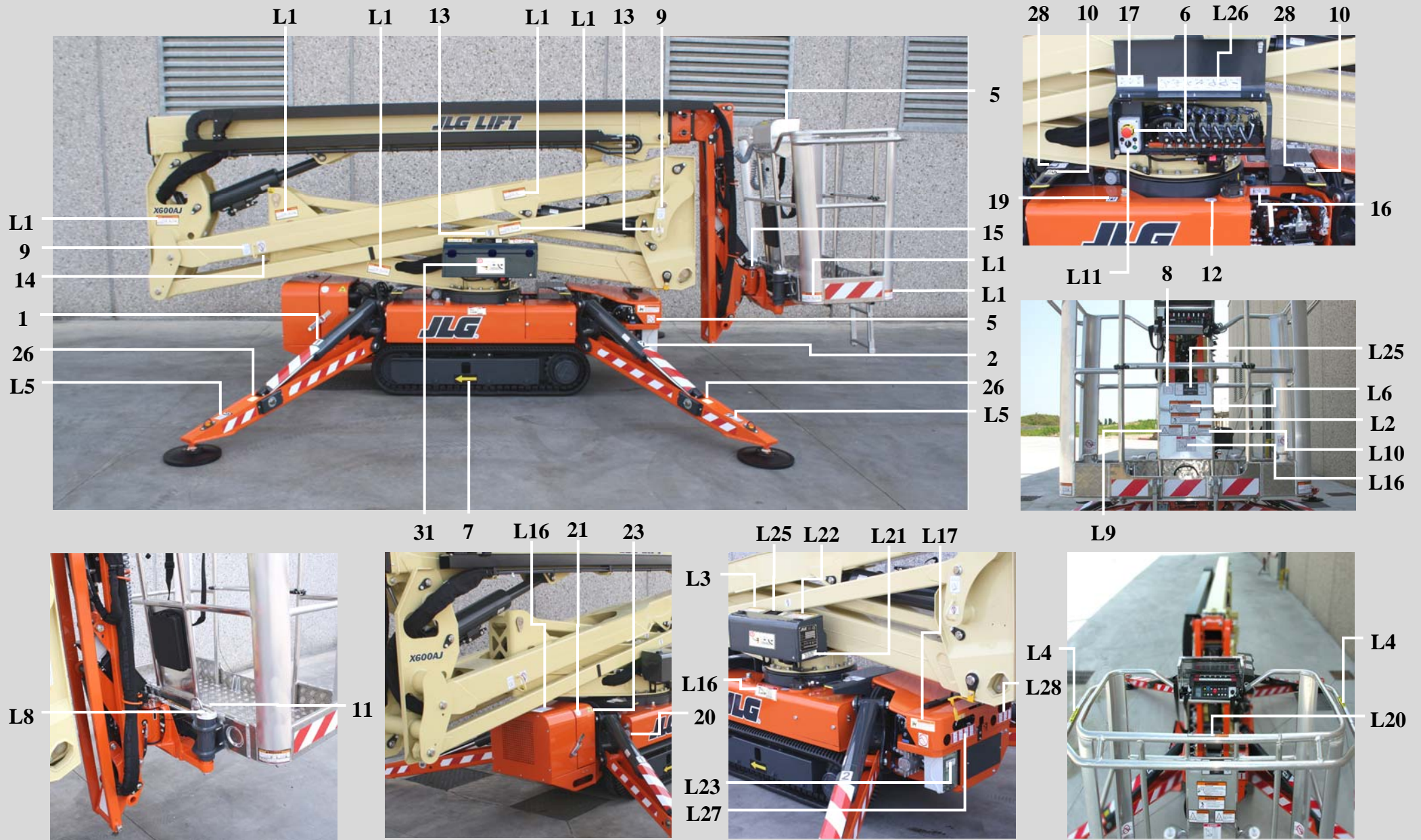

KIT ADESIVI - X600AJ

SET OF DECALS - X600AJ

KIT COLLANTS - X600AJ

AUFKLEBERSATZ - X600AJ

KIT ADHESIVOS - X600AJ

ADHESIEKIT - X600AJ

Cod. 17485000

Tav 01

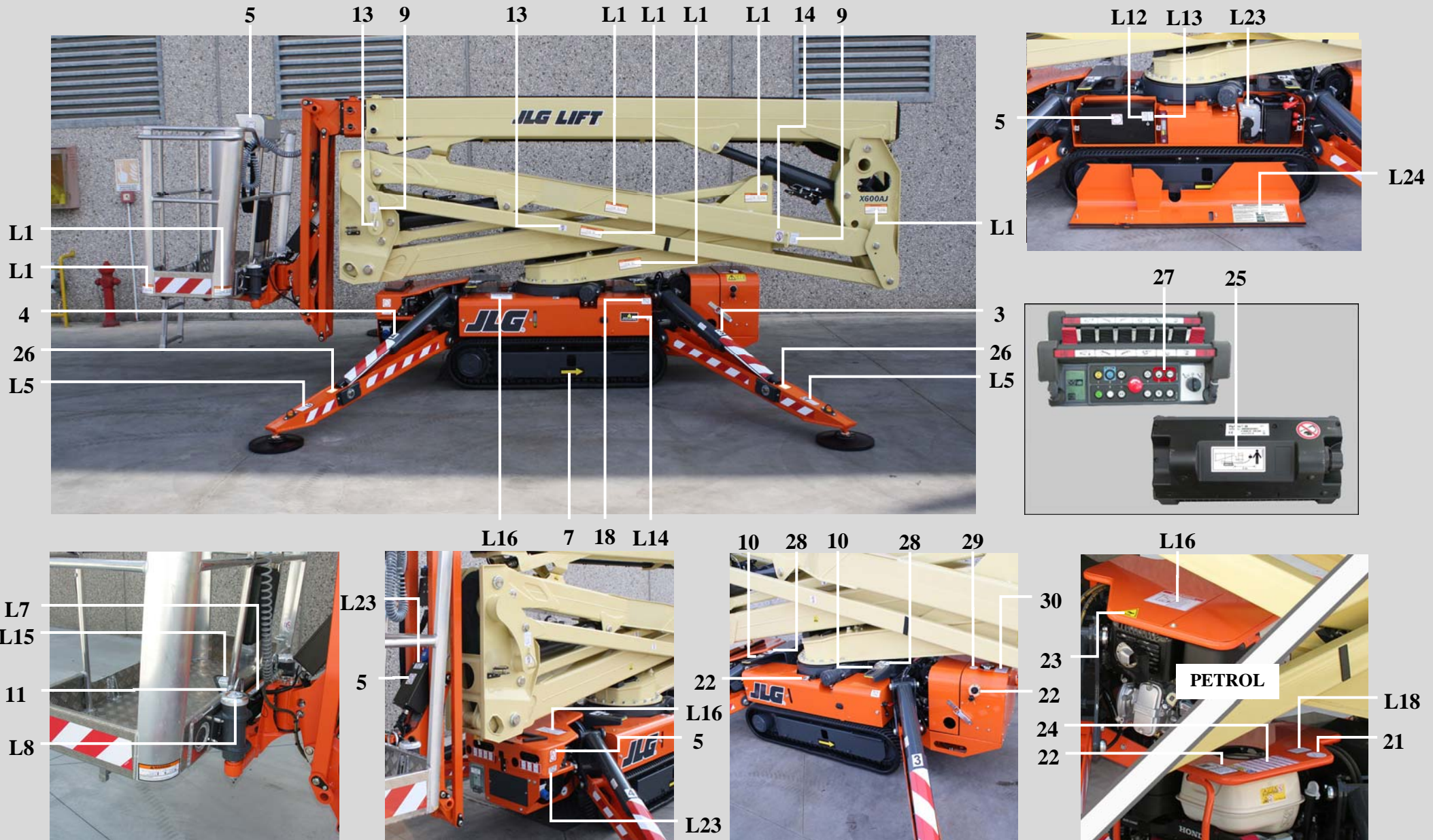

KIT ADESIVI - X600AJ

SET OF DECALS - X600AJ

KIT COLLANTS - X600AJ

AUFKLEBERSATZ - X600AJ

KIT ADHESIVOS - X600AJ

ADHESIEKIT - X600AJ

Cod. 17485000

Tav 02

Cod. 17485000

**KIT ADESIVI SICUREZZA PIATTAFORMA AEREA /
AERIAL PLATFORM KIT STICKERS SAFETY
JLG / ANSI - X600AJ**

17485000 POSIZIONE ADESIVI / POSITION STICKERS	IN LINGUA / LANGUAGE	JLG
	VOLTAGGIO / VOLTAGE	

POSIZIONE	CODICE	REV.	DESCRIZIONE	QUANTITA'
01	06555500	A	ADESIVO NR 1 L=50X60 BIANCO	01
02	06555600	A	ADESIVO NR 2 L=50X60 BIANCO	01
03	06555700	A	ADESIVO N° 3 L=50X60 BIANCO	01
04	06555800	A	ADESIVO N° 4 L=50X60 BIANCO	01
05	1001125483	A	ADESIVO JLG VIETATO LAVARE L=63,5X63,5 MM	06
06	1706898	A	ADESIVO JLG EMERGENCY STOP Ø EST.57,15 Ø INT. 30,58	01
07	06040500	A	ADESIVO DIREZ. TRASLAZIONE FRECCIA GIALLA SFONDO NERO L=61 X 160	02
08	1701640	A	ADESIVO JLG LEGGERE IL MANUALE L= 69,85x69,85 MM	01
09	1703814	A	ADESIVO JLG ATTACCO ANCORAGGIO L=55,56X76,2 MM	04
10	07071200	A	ADESIVO JLG PUNTO DI SOLLEVAMENTO L= 40X66 MM	04
11	1704277	A	ADESIVO JLG ATTACCO CINTURE DI SICUREZZA L= 76,2X19,05 MM	02
12	06164700	A	ADESIVO FILTRO OILO IDRAULICO Ø SFONDO BIANCO	01
13	07056700	A	ADESIVO JLG DIVIETO DI SOLLEVAMENTO L=40X54,88	04
14	1701499	A	ADESIVO JLG DIVIETO DI SOLLEVAMENTO DAL PUNTO DI ANCORAGGIO L= 55,56X76 MM (**)	02
15	06706500	A	ADESIVO ALLINEAMENTO CESTO (2 PEZZI) L=16X50+13	01
16	06998800	A	ADESIVO DEVIATORE POMPA MANUALE PIATTAFORMA GL17.80XL L=86X34	01
17	07242000	A	ADESIVO SELETTORE 3 POSIZIONI 2° TELECOMANDO	01
18	1702155	A	ADESIVO JLG STACCABATTERIA L= 63,5X50,80 MM	01
19	1701504	A	ADESIVO JLG OLIO IDRAULICO L=50,8x63,5 MM	01
20	06165000	A	ADESIVO LIVELLO OLIO IDRAULICO Ø50 SFONDO BIANCO	01
21	06060000	A	ADESIVO LIVELLO OLIO MOTORE Ø50mm	01
22	1701542	A	ADESIVO JLG CARBURANTE BENZINA L= 101X63,5	01
	1701505	A	ADESIVO JLG CARBURANTE DIESEL L= 50,8X63,5	01
23	06056300	A	ADESIVO PERICOLO SCOTTATURE L=60X51 TRIANGOLARE SFONDO GIALLO	01

**KIT ADESIVI IN LINGUA /
LANGUAGEKIT STICKERS
JLG / ANSI- X600AJ**

Cod.

174850GB

174850FR

174850ES

174850PT

174850** ADESIVI IN LINGUA / ADHESIVES IN LANGUAGE	IN LINGUA / LANGUAGE	JLG
	VOLTAGGIO / VOLTAGE	

POSIZIONE	CODICE	REV.	DESCRIZIONE	QUANTITA'
	174850GB		KIT ADESIVI SICUREZZA PIATTAFORMA AEREA X600AJ JLG / ANSI LINGUA INGLESE	
L1	07056100	A	ADESIVO JLG PERICOLO SCHIACCIAMENTO L= 140x60,71 MM	14
L2	1706387	A	ADESIVO JLG PERICOLO SCHIACCIAMENTO L=177,80x69,85 MM (SUL CESTO)	01
L3	1706099	A	ADESIVO JLG PERICOLO SCHIACCIAMENTO L= 161,92X69,85 MM (A TERRA)	01
L4	1702868	B	ADESIVO JLG PERICOLO SCHIACCIAMENTO MANO L= 241,30X25.40 MM (SUL CESTO)	02
L5	07056200	A	ADESIVO JLG ATTACCO SCHIACCIAMENTO ARTO INFERIORE L= 110x60 (PRES. STABILIZZATORI)	04
L6	1706386	A	ADESIVO JLG PERICOLO CADUTE L=196,85x76,2 MM	01
L7	07051100	A	ADESIVO JLG PERICOLO CADUTA - RIPRISTINARE I TAPPI L=196,5x35 MM	01
L8	07051000	A	ADESIVO JLG PERICOLO DI CADUTA - SBLOCCARE SOLO NEI CASI PREVISTI L= 50X50 MM	02
L9	1706133	C	ADESIVO JLG PERICOLO RIBALTAMENTO L=139,7X68,85 MM	01
L10	07058600	A	ADESIVO JLG POSIZIONE STABILIZZATORI X390, X550	01
L11	07349200	A	ADESIVO AVVIAMENTO MOTORE DA TERRA LL2010 IIIS L=76,5X37 MM	01
L12	07042100	A	ADESIVO JLG SISTEMA BYPASS PARTE AEREA L=30X50	01
L13	07042200	A	ADESIVO JLG SISTEMA BYPASS TRASLAZIONE L= 30X50	01
L14	1702901	A	ADESIVO JLG ISTRUZIONI DISCESA EMERGENZA / POMPA MAUALE L=114,3x58,73MM	01
L15	3252347	B	ADESIVO JLG ATTENZIONE PEDALE L= 69,85x57,15 MM	01
L16	1706128	E	ADESIVO JLG PERICOLO DI FOLGORAZIONE L=120,65x91,50 MM	05
L17	1703813	A	ADESIVO JLG PERICOLO ESLOSIONE BATTERIE L=149,25X47,62 MM	01
L18	1704972	C	ADESIVO JLG PERICOLO ESPLOSIONE L=63,5x92,07 MM	01
L19				
L20	1706385	C	ADESIVO JLG SCORRIMENTO SBARRA CHIUSURA CESTO L=184,15X25,4 MM	01
L21	1705514	A	ADESIVO JLG CONFORMITA' CSA L= 76,20x22,22 MM	01
L22	1706135	B	ADESIVO JLG USO PIATTAFORMA (GB) L=139,70x88,90 MM	01
L23	07056400	B	ADESIVO JLG PERICOLO 120V - 60HZ L= 75x32,68 MM	04

AGGIORNATO IL / UPDATED 28/11/2019

Cod. 17485100 (no a ricambio/no spare kit)

**KIT ADESIVI COMMERCIALI PIATTAFORMA AEREA /
STICKERS KIT COMMERCIAL AERIAL PLATFORM
JLG/ANSI X600AJ-MK2**

DA USARE CON / *FOR USE WITH*

**- 17777000 KIT ADESIVI SICUREZZAPIATTAFORMA AEREA JLG/ANSI X600AJ-MK2
*/ AERIAL PLATFORM SECURITY STICKERS KIT JLG/ANSI X600AJ-MK2***

Centrare il logo X600AJ in altezza e larghezza fra lo spazio rimanente
Center the logo X600AJ in height and width among the remaining space

A stabilizzatori chiusi centrare sul braccio sia in altezza che in larghezza il logo JLG LIFT
A closed centralise regulators on arm is in height to width in the logo JLG LIFT

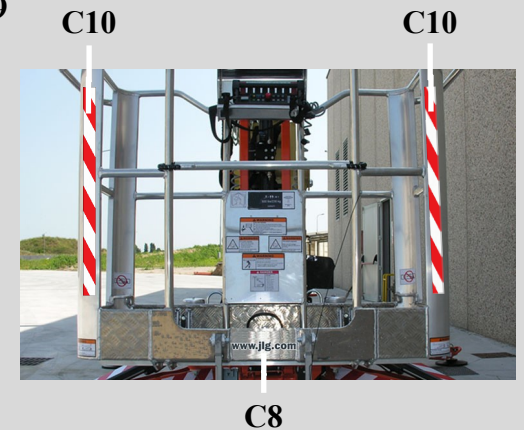
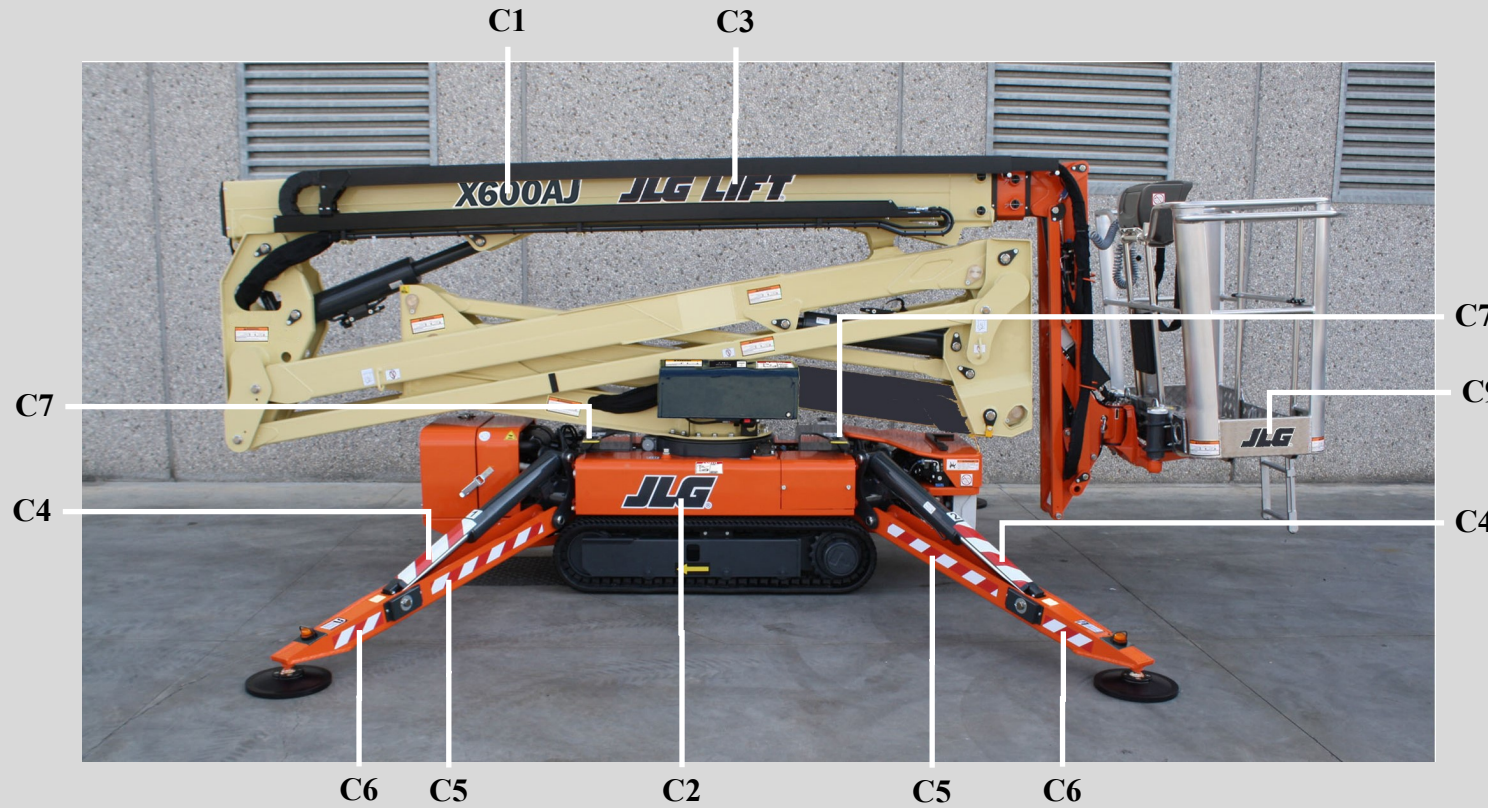

KIT ADESIVI - X600AJ - MK2	AUFKLEBERSATZ - X600AJ - MK2	Cod. 17485100	
SET OF DECALS - X600AJ - MK2	KIT ADHESIVOS - X600AJ - MK2		
KIT COLLANTS - X600AJ - MK2	ADHESIEKIT - X600AJ - MK2	Ed. 28/11/2019	Tav 01

A stabilizzatori chiusi centrare sul braccio sia in altezza che in larghezza il logo JLG LIFT
A closed centralise regulators on arm is in height to width in the logo JLG LIFT

Centrare il logo X600AJ in altezza e larghezza fra lo spazio rimanente
Center the logo X500AJ in height and width among the remaining space

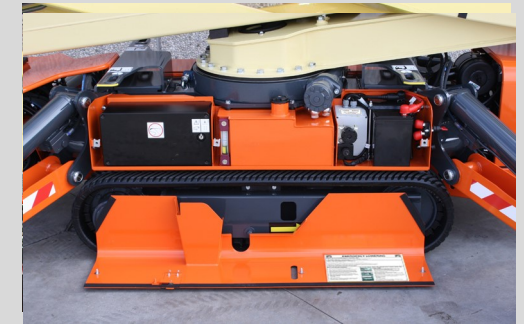
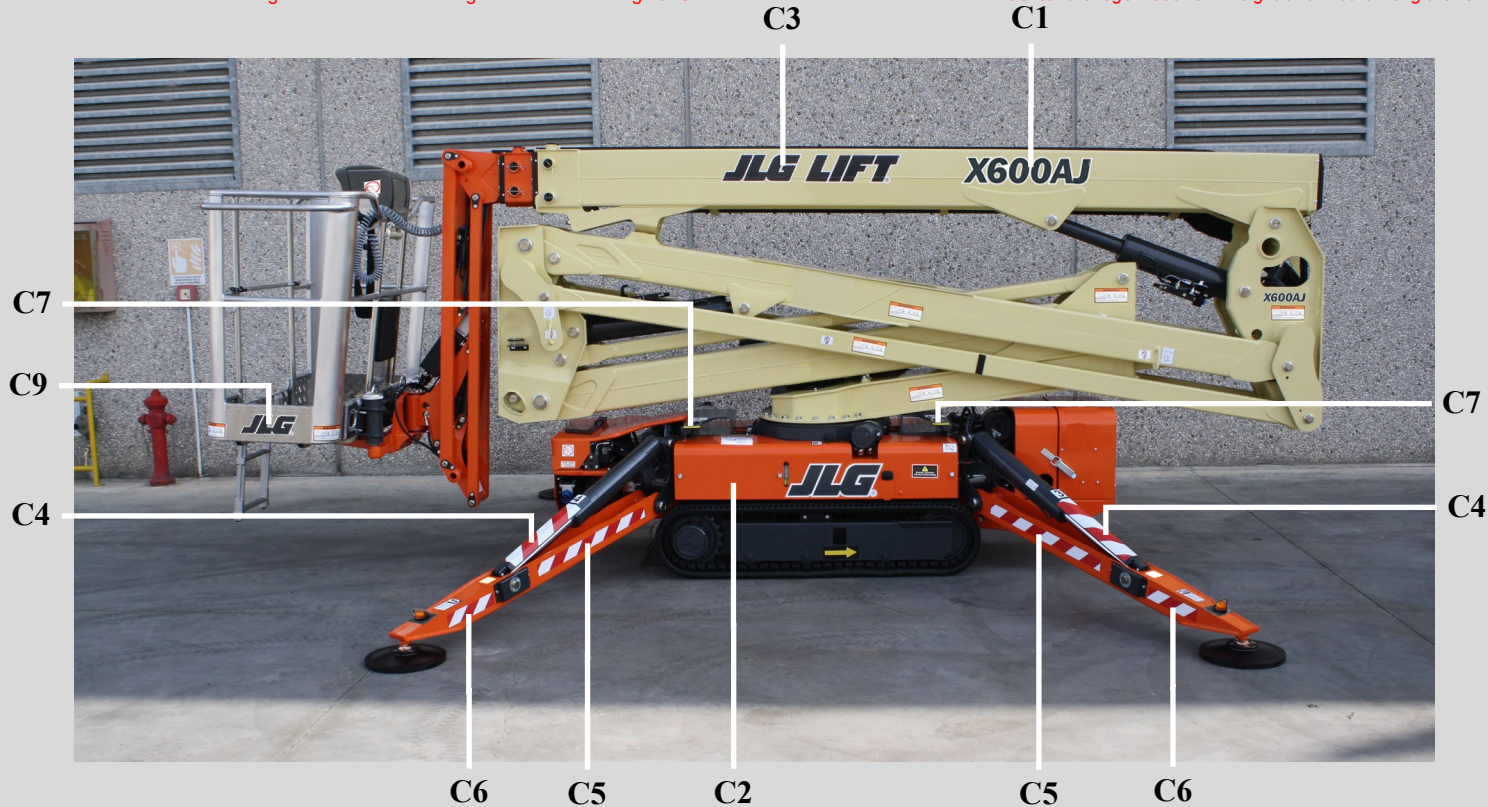

KIT ADESIVI - X600AJ - MK2

SET OF DECALS - X600AJ - MK2

KIT COLLANTS - X600AJ - MK2

AUFKLEBERSATZ - X600AJ - MK2

KIT ADHESIVOS - X600AJ - MK2

ADHESIEKIT - X600AJ - MK2

Cod. 17485100

Ed. 28/11/2019

Tav 02

POSIZIONE ADESIVI / POSITION STICKERS
JLG /ANSI - X600AJ-MK2 COD. 17485100
Aggiornato il / Updated 28/11/2019

IN LINGUA / LANGUAGE

JLG

VOLTAGGIO / VOLTAGE

POS.	COD.	REV.	DESCRIZIONE / DESCRIPTION	Q.tà
C1	07846700	A	ADESIVO JLG LOGO PIATTAFORMA AEREA CINGOLATA X600AJ L=605X130 MM	02
C2	07060500	A	ADESIVO JLG LOGO JLG COLORE GRIGIO PANTONE 432C L=432x150MM (**)	02
C3	07060700	A	ADESIVO JLG LOGO JLG LIFT COLORE GRIGIO PANTONE 432C L=809x130 MM (**)	02
C4	06086700	A	ADESIVO CON RIGHE BIANCHE E ROSSE L=430X100 (**)	04
C5	06039600	A	ADESIVO CON RIGHE BIANCHE ROSSE L= 700 X 50 (**)	08
C6	06040100	A	ADESIVO CON RIGHE BIANCHE ROSSE L= 240 X 50 (**)	08
C7	07268300	A	ADESIVO ATTENZIONE SOLLEVAMENTO FORCHE L= 80X7 MM	04
C8	07691500	A	ADESIVO LOGO WWW.JLG.COM COLORE PANTONE 432C L=200X33 MM	01
C9	07690100	A	ADESIVO JLG - LOGO JLG PER CESTO COLORE GRIGIO PANTONE 432C L=300x104,2 MM	02
C10	06039700	A	ADESIVO CON RIGHE BIANCHE ROSSE L= 700 X 80 MM	02
C11				
C12				
C13				
C14				
C15				
C16				
C17				
C18				
C19				
C20				
C21				
C22				
C23				
C24				

Cod. 17776600

KIT ADESIVI SICUREZZA PER PIATTAFORMA AEREA /
STICKERS KIT SAFETY FOR AERIAL PLATFORM
JLG/CE X20JPLUS - MK2

+ **Kit in lingua non inclusi nel codice generale** + *language code not included in the standard kit*

177766IT / 177766GB / 177766FR / 177766DE / 177766ES / 177766NL / 177766SW /
177766PT / 177766DA / 177766NO / 177766RU / 177766PL / 177766SL / 177766FI /
177766CE / 177766JA

DA USARE CON / FOR USE WITH

17351900 KIT ADESIVI COMMERCIALI PIATTAFORMA AEREA X20JPLUS /
STICKER KITS COMMERCIAL AERIAL PLATFORM X20JPLUS

17187700 KIT INTEGRAZIONE ADESIVI PER PIATTAFORME AEREE JLG/CE LITHIUM /
INTEGRATION KIT STICKERS PLATFORMS JLG / CE LITHIUM

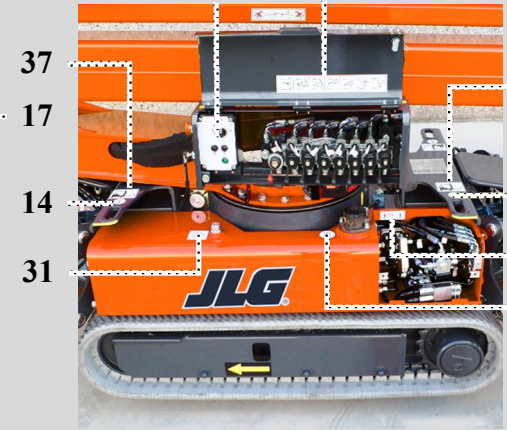
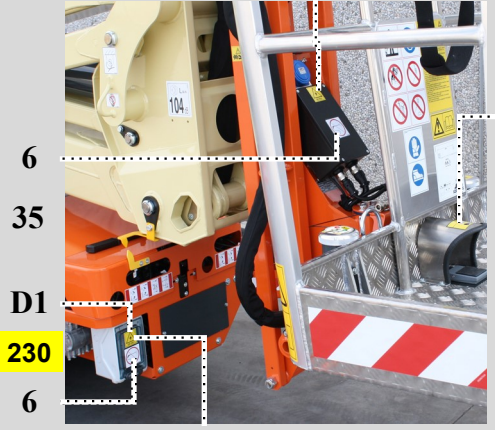
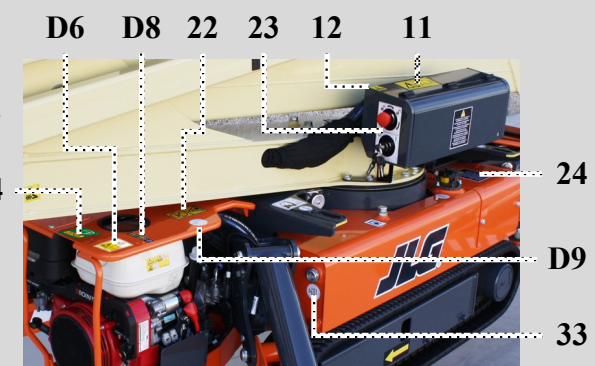
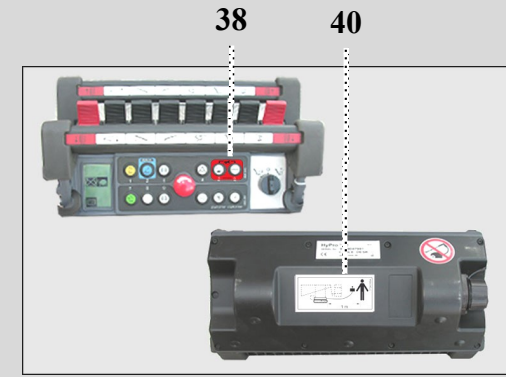
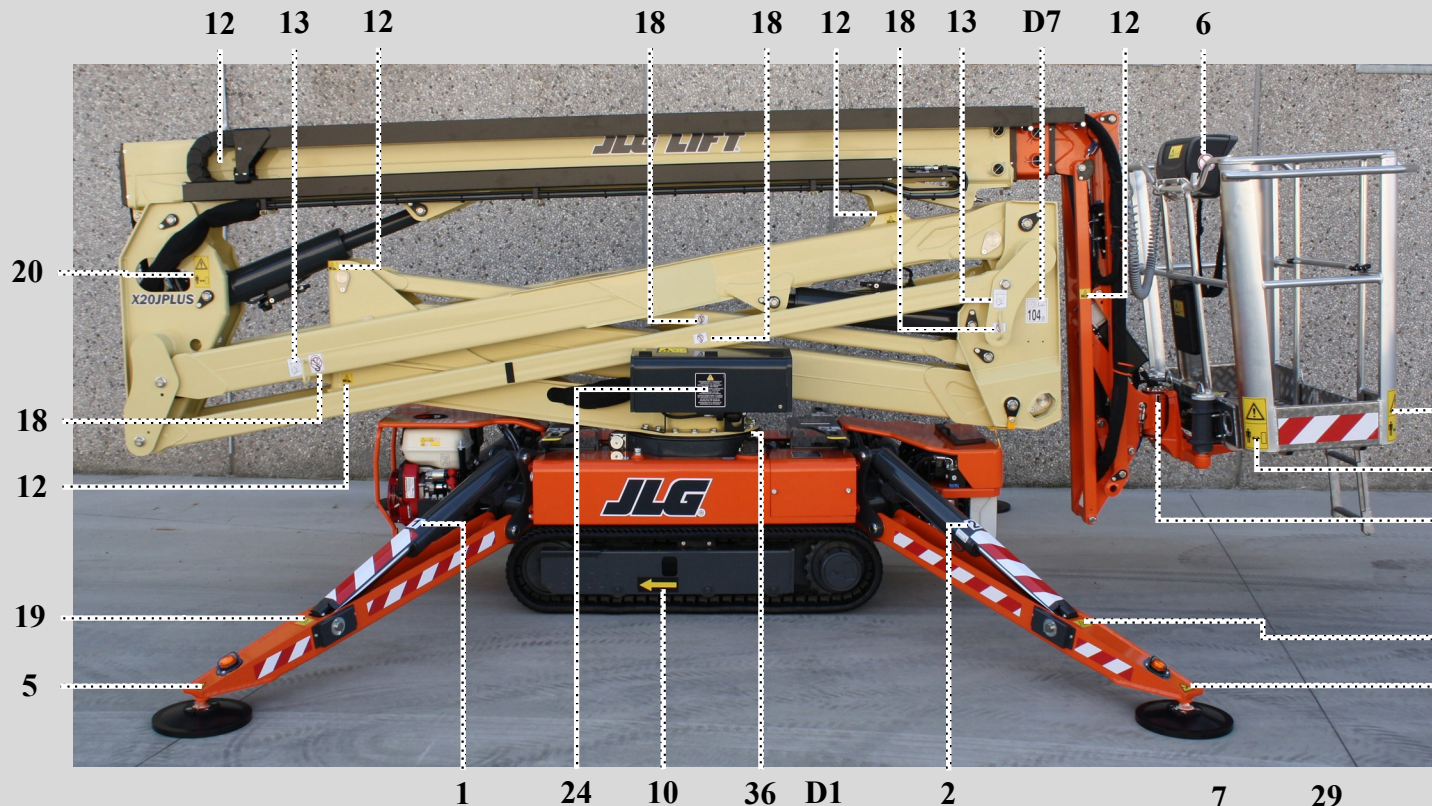

D2 110

KIT ADESIVI - JLG LIFT X20JPLUS - MK2

SET OF DECALS - JLG LIFT X20JPLUS - MK2

KIT COLLANTS - JLG LIFT X20JPLUS - MK2

AUFKLEBERSATZ - JLG LIFT X20JPLUS - MK2

KIT ADHESIVOS - JLG LIFT X20JPLUS - MK2

ADHESIEKIT - JLG LIFT X20JPLUS - MK2

cod. 17776600

Tav 01

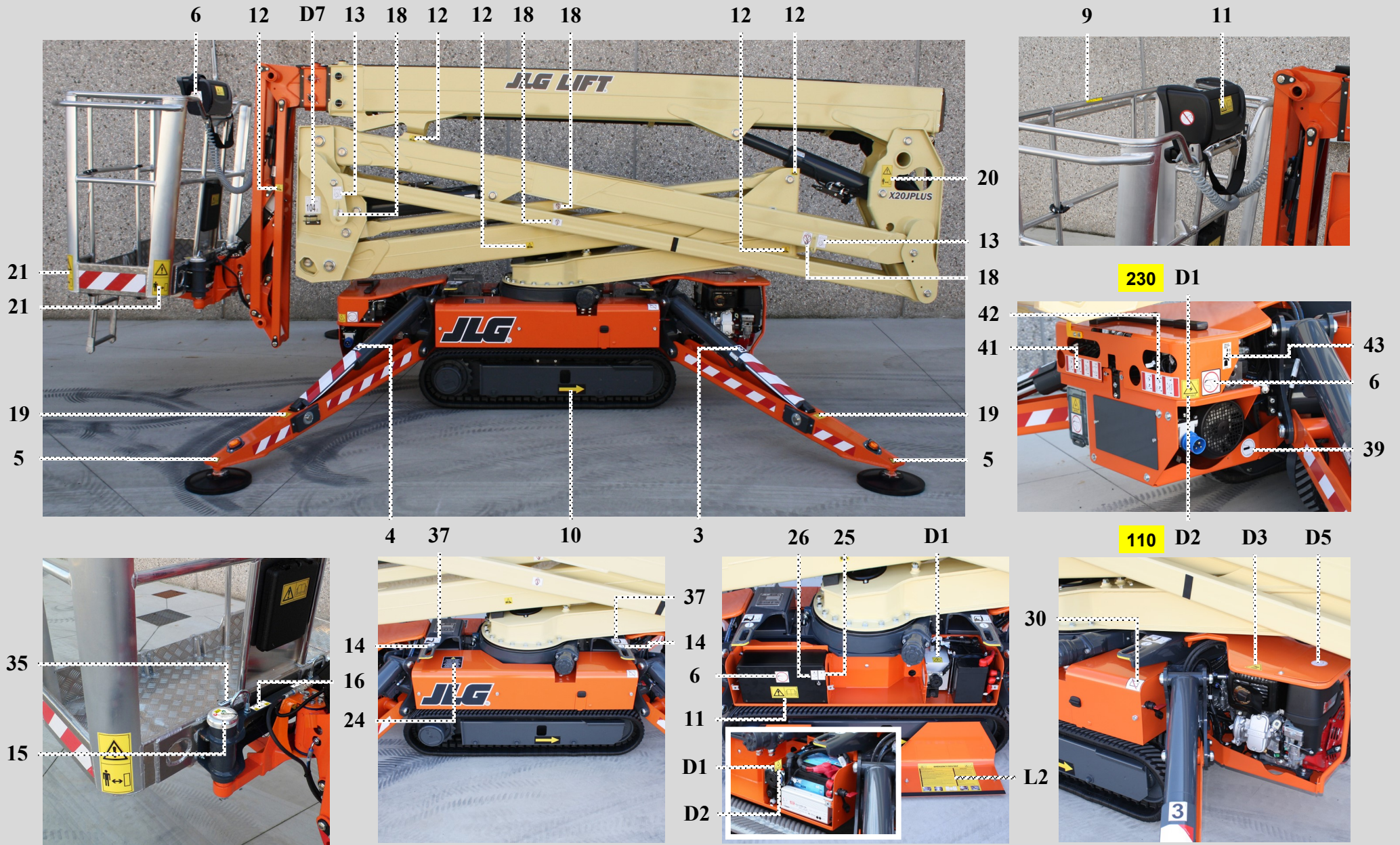

KIT ADESIVI - JLG LIFT X20JPLUS - MK2

SET OF DECALS - JLG LIFT X20JPLUS - MK2

KIT COLLANTS - JLG LIFT X20JPLUS - MK2

AUFKLEBERSATZ - JLG LIFT X20JPLUS - MK2

KIT ADHESIVOS - JLG LIFT X20JPLUS - MK2

ADHESIEKIT - JLG LIFT X20JPLUS - MK2

cod. 17776600

Tav 02

MOTORE DIESEL / DIESEL ENGINE



D4

D5

D10

11



22

D9

D6

D3

KIT ADESIVI - JLG LIFT X20JPLUS - MK2

SET OF DECALS - JLG LIFT X20JPLUS - MK2

KIT COLLANTS - JLG LIFT X20JPLUS - MK2

AUFKLEBERSATZ - JLG LIFT X20JPLUS - MK2

KIT ADHESIVOS - JLG LIFT X20JPLUS - MK2

ADHESIEKIT - JLG LIFT X20JPLUS - MK2

cod. 17776600

Tav 03

17776600 POSIZIONE ADESIVI / POSITION ADHESIVE

JLG

POS.	COD.	REV.	DESCRIZIONE / DESCRIPTION	Q.tà
01	06555500	A	ADESIVO NR 1 L=50X60 BIANCO	01
02	06555600	A	ADESIVO NR 2 L=50X60 BIANCO	01
03	06555700	A	ADESIVO N° 3 L=50X60 BIANCO	01
04	06555800	A	ADESIVO N° 4 L=50X60 BIANCO	01
05	06041200	A	ADESIVO SCHIACCIAMENTO PIEDI TRIANGOLARE L=53X46 GIALLO	04
06	1001125483	A	ADESIVO JLG VIETATO LAVARE L=63,5X63,5 MM (**)	06
07	07668300	A	ADESIVO SELETTORE SCATOLA COMANDI TERRA / CESTO L=105x155 MM	01
08	07878400	A	ADESIVO CASCO IMBRAGATURA E DIVIETI LL1370 L=175X118 MM	01
09	1706493	B	ADESIVO JLG SCORRIMENTO SBARRA CHIUSURA CESTO L= 76,2X25,4 MM _MOD_B (**)	01
10	06040500	A	ADESIVO DIREZ. TRASLAZIONE FRECCIA GIALLA SFONDO NERO L=61 X 160	02
11	06040900	A	ADESIVO LEGGERE IL MANUALE L=125 X 65 GIALLO	06
12	06041300	B	ADESIVO ATTENZIONE PERICOLO TAGLI L=35 X 40 GIALLO MM _MOD_B	11
13	1703814	A	ADESIVO JLG ATTACCO ANCORAGGIO L=55,56X76,2 MM (**)	04
14	06044000	A	ADESIVO ATTACCO SOLLEVAMENTO SFONDO BIANCO COLORE BLU Ø40 MM	04
15	06448200	B	ADESIVO SBLOCCARE SOLO NEI CASI PREVISTI" Ø 60 MM _MOD_B	02
16	06448100	B	ADESIVO RIPRISTINARE I TAPPI FERMO GUIDA L= 100X35 MM _MOD_B	02
17	1705828	B	ADESIVO JLG INTERUTTORE PEDALE L= 69,85X54 _MOD_B (**)	01
18	07056700	A	ADESIVO JLG DIVIETO DI SOLLEVAMENTO L=54,88X40 (**)	08
19	07320400	A	ADESIVO REAZIONE AL SUOLO STABILIZZATORI LL2010	04
20	07058800	A	ADESIVO PERICOLO MANTENERE LE DISTANZE L=65X130 MM	02
21	06040300	A	ADESIVO PERICOLO MANTENERE LE DISTANZE GIALLO L=100 X 200 MM (**)	04
22	1706098	B	ADESIVO JLG PERICOLO ESPLOSIONE L=63,5X117,475 MM _MOD_B (**)	01
23	07668200	B	ADESIVO EMERGENCY STOP E BLOCCHETTO ACCENSIONE L=85x160 MM _MOD_B	01
24	07056800	B	ADESIVO JLG DISCESA DI EMERGENZA ALL'INTERNO L=114X130 MM _MOD_B(**)	03

17776600 POSIZIONE ADESIVI / POSITION ADHESIVE

JLG

POS.	COD.	REV.	DESCRIZIONE / DESCRIPTION	Q.tà
25	06086000	A	ADESIVO SISTEMA BYPASS TRASLAZIONE L=30X50	01
26	06085900	A	ADESIVO SISTEMA BYPASS PARTE AEREA L=30X50	01
27	06706500	A	ADESIVO ALLINEAMENTO CESTO (2 PEZZI) L=16X50+13	01
28	06998800	A	ADESIVO DEVIATORE POMPA MANUALE PIATTAFORMA GL17.80XL L=86X34	01
29	07668100	A	ADESIVO PULSANTI DISTRIBUTORE PARTE AEREA LL2614 L=318X52 MM	01
30	1702155	A	ADESIVO JLG STACCABATTERIA L= 63,5X50,80 MM (**)	01
31	1701504	A	ADESIVO JLG OLIO IDRAULICO L=50,8x63,5 MM (**)	01
32	06164700	A	ADESIVO FILTRO OLIO Ø50 SFONDO BIANCO	01
33	06165000	A	ADESIVO LIVELLO OLIO IDRAULICO Ø50 SFONDO BIANCO	01
34	07397200	A	ADESIVO JLG X20JPLUS PORTATA CESTO 2 PERSONE L=135X145 MM	01
35	1704277	A	ADESIVO JLG ATTACCO CINTURE DI SICUREZZA L= 76,2X19,05 MM	02
36	06922700	A	ADESIVO FRECCIA ALLINEAMENTO L=50x15 (**)	02
37	07350300	A	ADESIVO SOLLEVAMENTO PIATTAFORMA CON MULETTO L=90X70 MM	04
38	07071000	B	ADESIVO JLG CLAXON SU PIATTAFORME L=38,3X28,55 MM _MOD_B (**)	01
39	06136900	A	ADESIVO PUNTI DI INGRASSAGGIO Ø 55 mm	01
40	07240300	B	ADESIVO DISTANZA 1m SU TELE/RADIO COMANDI MM _MOD_B	01
41	1608710001	C	ADESIVO PULSANTI DISTR. A TERRA LATO SX GL17.80 L=194X50 MM _MOD_C	01
42	1608710002	C	ADESIVO PULSANTI DISTRIB A TERRA GL 17.80 LATO DX L= 150X50 MM _MOD_C	01
43	1704125	A	ADESIVO JLG ATTACCO ARIA E ACQUA L=25,4X76,2 MM (da montare dalla prossima barra in produzione da gennaio 2018)	01
44				
45				
46				
47				

17776600 POSIZIONE ADESIVI / POSITION ADHESIVE

POS.	COD.	REV.	ADESIVI IN DISTINTA MACCHINA / STICKERS IN LIST MACHINE	Q.tà
D1	06561200	B	ADESIVO PERICOLO 230 VOLT16 AMPERE GIALLO L=47X47 MM _MOD_B	04
	06042400	B	ADESIVO PERICOLO 110 VOLT16 AMPERE GIALLO L=47 X 47 MM _MOD_B	04
	06257300	A	ADESIVO PERICOLO 240 VOLT GIALLO L=47 X 47 MM	04
D2	07668000	A	ADESIVO PERICOLO 110 VOLT 32A GIALLO L=47 X 47 MM	02
D3	06056300	A	ADESIVO PERICOLO SCOTTATURE TRIANGOLARE SFONDO GIALLO L=60X51 MM	01
D4	06041600	B	ADESIVO CARBURANTE BENZINA COLORE VERDE L=60 X 80 MM _MOD_B	01
	06043900	A	ADESIVO CARBURANTE DIESEL SFONDO BIANCO Ø 50 MM	01
D5	06164600	A	ADESIVO FILTRO ARIA SFONDO BIANCO Ø50 MM	01
D6	06227200	B	ADESIVO CONTROLLARE LIVELLO OLIO MOTORE L=80X80 MM _MOD_B	01
D7	07802200	B	ADESIVO RUMORE 102 dB L=90X100 MM _MOD_B	02
D8	06232100	B	ADESIVO ATTENZIONE BENZINA INFIAMMABILE L=170X42 MM _MOD_B	01
D9	06060000	A	ADESIVO LIVELLO OLIO MOTORE Ø50 MM	01
D10	06214200	A	ADESIVO LIQUIDO REFRIGERANTE SFONDO BIANCO Ø 50	01
D11				
D12				
D13				
D14				
D15				
D16				
D17				
			PER MACCHINE CON CESTO A 1 PERSONA / FOR MACHINE WITH BASKET 1 PERSONA	
43	07669100	B	ADESIVO JLG X20JPLUS PORTATA CESTO 1 PERSONA L=135X145 MM - NON IN DISTINTA	01

177766 POSIZIONE ADESIVI IN LINGUA / POSITION LANGUAGE STICKERS**

POS.	COD.	REV.	DESCRIZIONE / DESCRIPTION	Q.tà
	1777661IT		ADESIVI PIATTAFORMA AEREA CINGOLATA X20JPLUS - MK2 - LINGUA ITALIANO	
L1	06555300	C	ADESIVO USO PIATTAFORMA LINGUA ITALIANO LL 23.12 L=128X230 MM_MOD_C	01
L2	07348900	A	ADESIVO DISCESA DI EMERGENZA LL 2010 MOTORE TERMICO E LITHIUM - ITA L=290X205 MM	01
	177766GB		ADESIVI PIATTAFORMA AEREA CINGOLATA X20JPLUS - MK2 - LINGUA INGLESE	
L1	06562600	C	ADESIVO USO PIATTAFORMA INGLESE L=128X230 MM_MOD_C	01
L2	073489GB	A	ADESIVO DISCESA DI EMERGENZA LL 2010 MOTORE TERMICO E LITHIUM - ING L=290X205 MM	01
	177766FR		ADESIVI PIATTAFORMA AEREA CINGOLATA X20JPLUS - MK2 - LINGUA FRANCESE	
L1	06562700	C	ADESIVO USO PIATTAFORMA FRANCESE L=128X230 MM_MOD_C	01
L2	073489FR	A	ADESIVO DISCESA DI EMERGENZA LL2010 MOTORE TERMICO E LITHIUM - FRA L=290X205 MM	01
	177766DE		ADESIVI PIATTAFORMA AEREA CINGOLATA X20JPLUS - MK2 - LINGUA TEDESCO	
L1	06562800	C	ADESIVO USO PIATTAFORMA TEDESCO L=128X230 MM_MOD_C	01
L2	073489DE	A	ADESIVO DISCESA DI EMERGENZA LL 2010 MOTORE TERMICO E LITHIUM - TED L=290X205 MM	01
	177766ES		ADESIVI PIATTAFORMA AEREA CINGOLATA X20JPLUS - MK2 - LINGUA SPAGNOLO	
L1	06562900	C	ADESIVO USO PIATTAFORMA SPAGNOLO L=128X230 MM_MOD_C	01
L2	073489ES	A	ADESIVO DISCESA DI EMERGENZA LL 2010 MOTORE TERMICO E LITHIUM - SPA L=290X205 MM	01
	177766NL		ADESIVI PIATTAFORMA AEREA CINGOLATA X20JPLUS - MK2 - LINGUA OLANDESE	
L1	06563000	C	ADESIVO USO PIATTAFORMA OLANDESE L=128X230 MM_MOD_C	01
L2	073489NL	A	ADESIVO DISCESA DI EMERGENZA LL 2010 MOTORE TERMICO E LITHIUM - OLA L=290X205 MM	01

177766 POSIZIONE ADESIVI IN LINGUA / POSITION LANGUAGE STICKERS**

POS.	COD.	REV.	DESCRIZIONE / DESCRIPTION	Q.tà
	177766SW		ADESIVI PIATTAFORMA AEREA CINGOLATA X20JPLUS - MK2 - LINGUA SVEDESE	
L1	07137300	C	ADESIVO USO PIATTAFORMA AEREA CINGOLATA - SVEDESE L= 128X230 MM _MOD_C	01
L2	073489SW	A	ADESIVO DISCESA DI EMERGENZA LL2010 MOTORE TERMICO E LITHIUM - SVE L=290X205 MM	01
	177766PT		ADESIVI PIATTAFORMA AEREA CINGOLATA X20JPLUS - MK2 - LINGUA PORTOGHESE	
L1	06563100	C	ADESIVO USO PIATTAFORMA PORTOGHESE L=128X230 MM _MOD_C	01
L2	073489PT	A	ADESIVO DISCESA DI EMERGENZA LL2010 MOTORE TERMICO E LITHIUM - POR L=290X205 MM	01
	1177766DA		ADESIVI PIATTAFORMA AEREA CINGOLATA X20JPLUS - MK2 - LINGUA DANESE	
L1	07138100	C	ADESIVO USO PIATTAFORMA DANESE L=128X230 MM _MOD_C	01
L2	073489DA	A	ADESIVO DISCESA DI EMERGENZA LL 2010 MOTORE TERMICO E LITHIUM - DAN L=290X205 MM	01
	177766NO		ADESIVI PIATTAFORMA AEREA CINGOLATA X20JPLUS - MK2 - LINGUA NORVEGESE	
L1	07162000	C	ADESIVO USO PIATTAFORMA AEREA CINGOLATA - NORVEGESE L=128X230 MM _MOD_C	01
L2	073489NO	A	ADESIVO DISCESA DI EMERGENZA .LL 2010 MOTORE TERMICO E LITHIUM - NOR L=290X205 MM	01
	177766RU		ADESIVI PIATTAFORMA AEREA CINGOLATA X20JPLUS - MK2 - LINGUA RUSSO	
L1	07514800	A	ADESIVO USO PIATTAFORMA AEREA CINGOLATA - RUSSO L=128X230 MM	01
L2	073489RU	A	ADESIVO DISCESA DI EMERGENZA LL2010 MOTORE TERMICO E LITHIUM - RUSSO L=290X205 MM	01
	177766PL		ADESIVI PIATTAFORMA AEREA CINGOLATA X20JPLUS - MK2 - LINGUA POLACCO	
L1	07506600	B	ADESIVO USO PIATTAFORMA AEREA CINGOLATA - POLACCO L= 128X230 MM _MOD_B	01
L2	073489PL	A	ADESIVO DISCESA DI EMERGENZA LL2010 MOTORE TERM. E LITHIUM - POL L=290X205 MM	01

**KIT ADESIVI SICUREZZA PER PIATTAFORMA AEREA /
AERIAL PLATFORM KIT STICKERS SAFETY
JLG/ANSI - X600AJ - MK2**

Cod. 17777000

Kit in lingua non inclusi nel codice generale + *Language code not included in the standard kit*

177770GB - 177770FR - 177770ES - 177770PT

DA USARE CON / FOR USE WITH

**17485100 KIT ADESIVI COMMERCIALI PIATTAFORMA AEREA JLG/ANSI - X600AJ - MK2
/ STICKERS KIT COMMERCIAL AERIAL PLATFORM JLG/ANSI - X600AJ - MK2**

**17107300 KIT ADESIVI INTEGRAZIONE PER PIATTAFORME JLG-ANSI LITIUM /
STICKER KIT FOR INTEGRATION LITIUM PLATFORM
X390AJ - X500AJ - X550AJ - X600AJ - X700AJ - X770AJ**

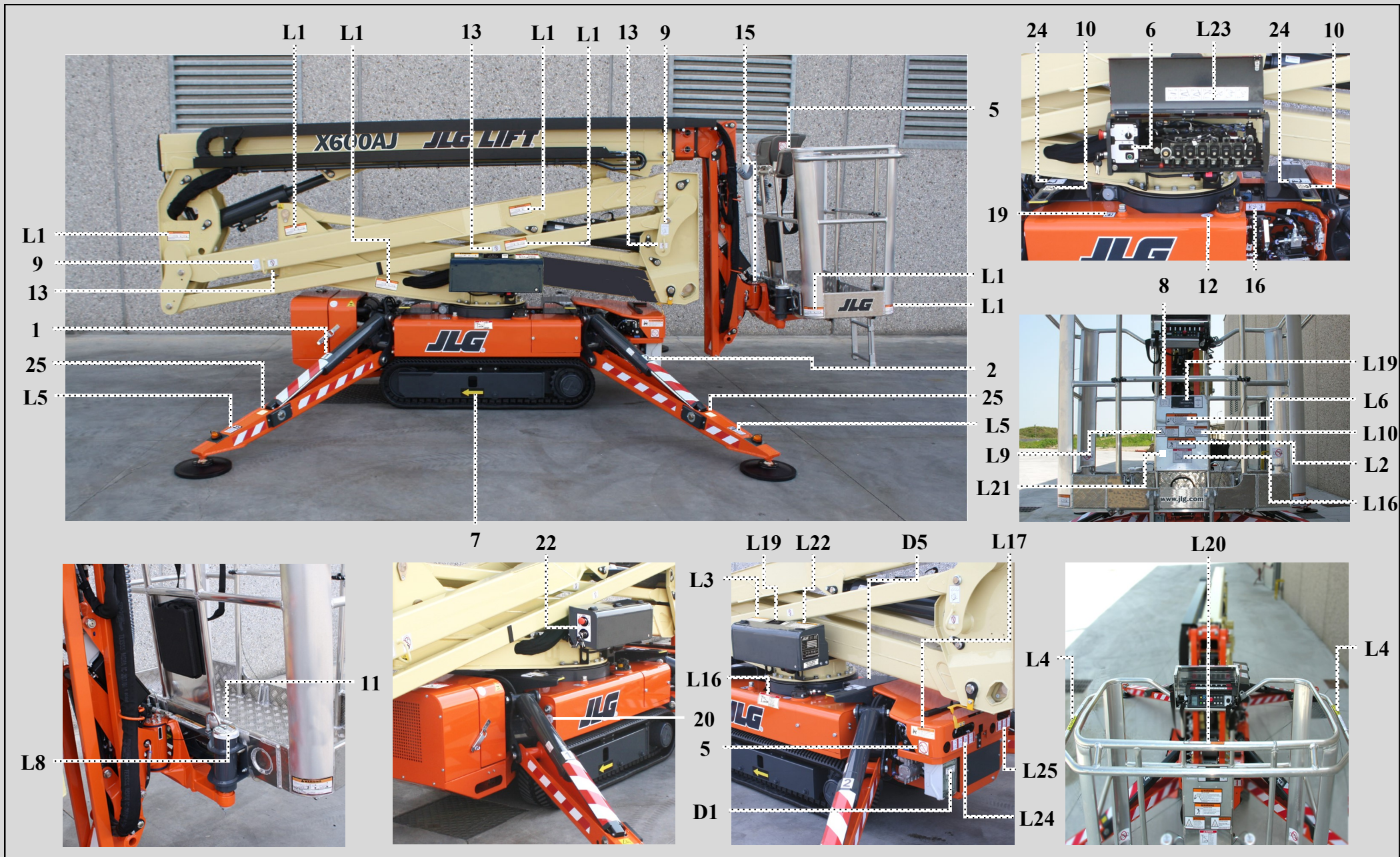

KIT ADESIVI - X600AJ - MK2

SET OF DECALS - X600AJ - MK2

KIT COLLANTS - X600AJ - MK2

AUFKLEBERSATZ - X600AJ - MK2

KIT ADHESIVOS - X600AJ - MK2

ADHESIEKIT - X600AJ - MK2

Cod. 17777000

Tav 01

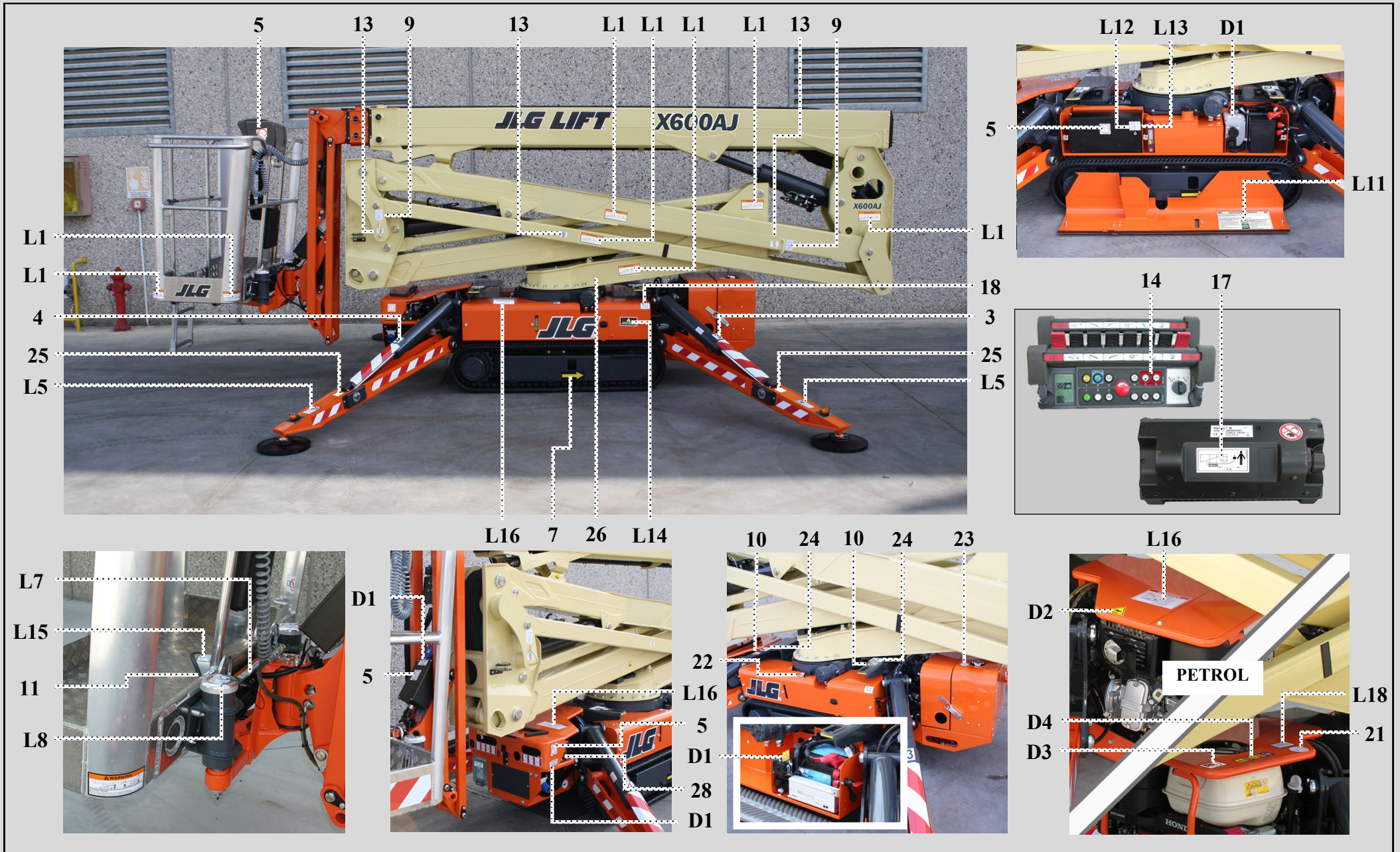

KIT ADESIVI - X600AJ - MK2	AUFKLEBERSATZ - X600AJ - MK2	Cod. 17777000
SET OF DECALS - X600AJ - MK2	KIT ADHESIVOS - X600AJ - MK2	
KIT COLLANTS - X600AJ - MK2	ADHESIEKIT - X600AJ - MK2	Tav 02

JLG/ANSI - X600AJ - COD 17777000 POSIZIONE ADESIVI / POSITION STICKERS

JLG

POSIZIONE	CODICE	REV.	DESCRIZIONE	QUANTITA'
01	06555500	A	ADESIVO NR 1 L=50X60 BIANCO	01
02	06555600	A	ADESIVO NR 2 L=50X60 BIANCO	01
03	06555700	A	ADESIVO N° 3 L=50X60 BIANCO	01
04	06555800	A	ADESIVO N° 4 L=50X60 BIANCO	01
05	1001125483	A	ADESIVO JLG VIETATO LAVARE L=63,5X63,5 MM	06
06	07668300	A	ADESIVO SELETTORE SCATOLA COMANDI TERRA / CESTO L=105X155 MM	01
07	06040500	A	ADESIVO DIREZ. TRASLAZIONE FRECCIA GIALLA SFONDO NERO L=61 X 160	02
08	1701640	A	ADESIVO JLG LEGGERE IL MANUALE L= 69,85x69,85 MM	01
09	1703814	A	ADESIVO JLG ATTACCO ANCORAGGIO L=55,56X76,2 MM	04
10	07071200	A	ADESIVO JLG PUNTO DI SOLLEVAMENTO L= 40X66 MM	04
11	1704277	A	ADESIVO JLG ATTACCO CINTURE DI SICUREZZA L= 76,2X19,05 MM	02
12	06164700	A	ADESIVO FILTRO OILO IDRAULICO Ø SFONDO BIANCO	01
13	07056700	A	ADESIVO JLG DIVIETO DI SOLLEVAMENTO L=40X54,88	06
14	07071000	B	ADESIVO JLG CLAXON SU PIATTAFORME L=38,3X28,55 _MOD_B	01
15	06706500	A	ADESIVO ALLINEAMENTO CESTO (2 PEZZI) L=16X50+13	01
16	06998800	A	ADESIVO DEVIATORE POMPA MANUALE PIATTAFORMA GL17.80XL L=86X34	01
17	07240300	B	ADESIVO DISTANZA 1m SU TELE/RADIO COMANDI _MOD_B	01
18	1702155	A	ADESIVO JLG STACCABATTERIA L= 63,5X50,80 MM	01
19	1701504	A	ADESIVO JLG OLIO IDRAULICO L=50,8x63,5 MM	01
20	06165000	A	ADESIVO LIVELLO OLIO IDRAULICO Ø50 SFONDO BIANCO	01
21	06060000	A	ADESIVO LIVELLO OLIO MOTORE Ø50mm	01
22	07668200	B	ADESIVO EMERGENCY STOP E BLOCCHETTO ACCENSIONE L=85x160 MM _MOD_B	01
23	06214200	A	ADESIVO LIQUIDO REFRIGERANTE SFONDO BIANCO Ø 50 MM (**)	01
24	07350300	A	ADESIVO SOLLEVAMENTO PIATTAFORMA CON MULETTO L=90X70 MM	04
25	07526800	A	ADESIVO REAZIONE AL SUOLO STABILIZZATORI X600AJ L= 50X50 - BIANCO	04
26	1001223055	A	ADESIVO JLG INSPEZIONE ANNUALE RICHIESTA	01
28	1704125	A	ADESIVO JLG ATTACCO ARIA E ACQUA	01

JLG/ANSI - X600AJ - COD. 177770 ADESIVI IN LINGUA / ADHESIVES IN LANGUAGE**

JLG

POS.				CODICE	DESCRIZIONE	Q.TA'
	177770FR	177770PT	177770ES	177770GB	KIT ADESIVI SICUREZZA PIATTAFORMA AEREA X600AJ JLG / ANSI LINGUA INGLESE	
L1	07116800	07121400		07056100	ADESIVO JLG PERICOLO SCHIACCIAMENTO L= 140x60,71 MM	14
L2	07119100	07123700		1706387	ADESIVO JLG PERICOLO SCHIACCIAMENTO L=177,80x69,85 MM (SUL CESTO)	01
L3	07118500	07123100		1706099	ADESIVO JLG PERICOLO SCHIACCIAMENTO L= 161,92X69,85 MM (A TERRA)	01
L4	07117800	07122400		1702868_B	ADESIVO JLG PERICOLO SCHIACCIAMENTO MANO L= 241,30X25.40 MM (SUL CESTO)_MOD_B	02
L5	07116900	07121500		07056200	ADESIVO JLG ATTACCO SCHIACCIAMENTO ARTO INFERIORE L= 110x60 (PRES. STABILIZZATORI)	04
L6	07119000	07123600		1706386	ADESIVO JLG PERICOLO CADUTE L=196,85x76,2 MM	01
L7	07116700	07121300		07051100_B	ADESIVO JLG PERICOLO CADUTA - RIPRISTINARE I TAPPI L=196,5x35 MM_MOD_B	01
L8	07116600	07121200		07051000	ADESIVO JLG PERICOLO DI CADUTA - SBLOCCARE SOLO NEI CASI PREVISTI L= 50X50 MM	02
L9	07118700	07123300		1706133_C	ADESIVO JLG PERICOLO RIBALTAMENTO L=139,7X68,85 MM_MOD_C	01
L10	07117200	07121800		07058600	ADESIVO JLG POSIZIONE STABILIZZATORI X390, X550	01
L11	075039FR	075039PT		075039GB	ADESIVO JLG DISCESA DI EMERGENZA X600AJ MOTORE TERMICO E LITHIUM - ING L=290X205 MM	01
L12	07115200	07119800		07042100	ADESIVO JLG SISTEMA BYPASS PARTE AEREA L=30X50	01
L13	07115300	07119900		07042200	ADESIVO JLG SISTEMA BYPASS TRASLAZIONE L= 30X50	01
L14	07117900	07122500		1702901	ADESIVO JLG ISTRUZIONI DISCESA EMERGENZA / POMPA MAUALE L=114,3x58,73MM	01
L15	07119200	07123800		3252347_B	ADESIVO JLG ATTENZIONE PEDALE L= 69,85x57,15 MM_MOD_B	01
L16	07118600	07123200		1706128_E	ADESIVO JLG PERICOLO DI FOLGORAZIONE L=120,65x91,50 MM_MOD_E	05
L17	07118200	07122800		1703813	ADESIVO JLG PERICOLO ESLOSIONE BATTERIE L=149,25X47,62 MM	01
L18	07118300	07122900		1704972_C	ADESIVO JLG PERICOLO ESPLOSIONE L=63,5x92,07 MM_MOD_C	01
L19	081081FR	081081PT		081081GB	ADESIVO JLG ANSI CARICO MAX IN CESTA X500AJ	02
L20	07118900	07123500		1706385_C	ADESIVO JLG SCORRIMENTO SBARRA CHIUSURA CESTO L=184,15X25,4 MM_MOD_C	01
L21	08069800	08069800		08069800	ADESIVO JLG ATTENZIONE PROP.65 L=101,6X57,1 MM RIF JLG CODE. 1001231801C	01
L22	07118800	07123400		1706135_B	ADESIVO JLG USO PIATTAFORMA (GB) L=139,70x88,90 MM_MOD_B	01
L23	076787FR	076787PT		076787GB	ADESIVO JLG ANSI PULSANTI DISTRIBUTORE PARTE AEREA X770AJ L=318X52 MM - ING	01
L24	072425FR	072425PT		072425GB	ADESIVO JLG ANSI PULSANTI DISTRIB A TERRA X500AJ LATO SX	01
L25	072426FR	072426PT		072426GB	ADESIVO JLG ANSI PULSANTI DISTR. A TERRA LATO DX X500AJ	01
	000000FR	000000PT		076385GB	ADESIVO JLG ANSI CARICO MAX IN CESTA 1 PERSONA X500AJ-X600AJ-X770AJ / ING L=196,85x76,2 MM NON IN DISTINTA	01

AGGIORNATO IL / UPDATED 30/10/2019

KIT ADESIVI CESTO MONOPOSTO E BIPOSTO PER PIATTAFORME AEREE /
BASKET KIT STICKERS SINGLE POSTAND TANDEM FOR PLATFORMS

SERIE/SERIES JLG/CE

X14J • X17J • X19J • X23J
X13JPLUS • X15JPLUS • X17JPLUS • X20JPLUS • X26JPLUS

CON MOTORE TERMICO E LITHIUM / WITH HEAT ENGINE AND LITHIUM

Cod. 17876800

+ kit adesivi portata cesto non inclusi nel codice generale
Sticker kits basket capacity not included in the standard kit

178768X14J / 178768X17J / 178768X19J / 178768X23J
178768X13JP / 178768X15JP / 178768X17JP / 178768X20JP / 178768X26JP

+ kit in lingua non inclusi nel codice generale
language code not included in the standard kit

174164IT / 1174164GB / 174164FR / 174164DE / 174164ES / 174164NL / 174164SW / 174164PT /
174164DA / 174164NO / 174164RU / 174164PL / 174164SL / 174164FI / 174164CE / 174164JA

JLG/CE X13JPLUS • X15JPLUS • X17JPLUS • X20JPLUS • X26JPLUS

JLG/CE 14J • X17J • X19J • X23J

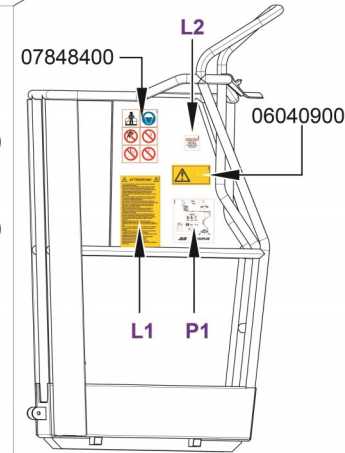
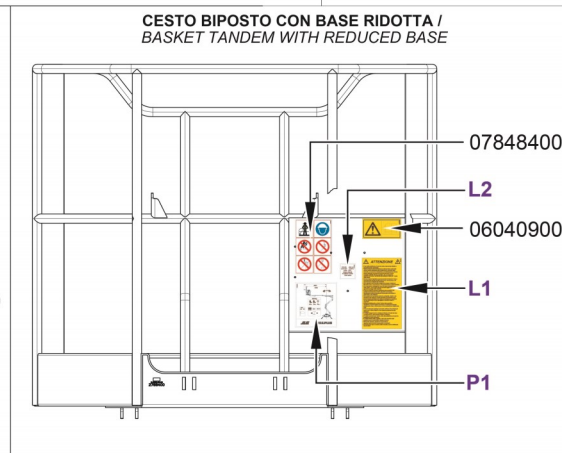
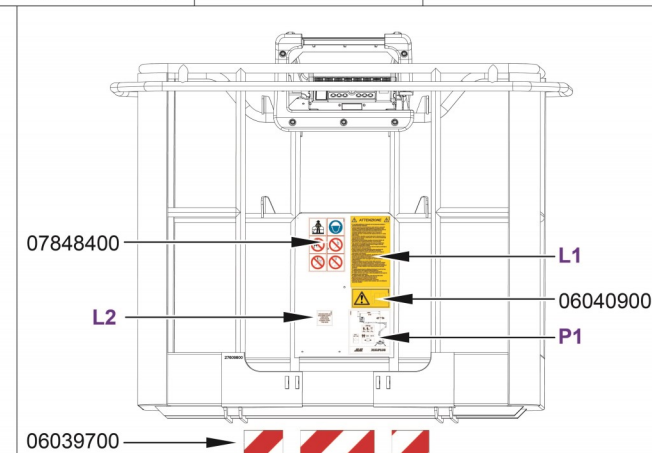
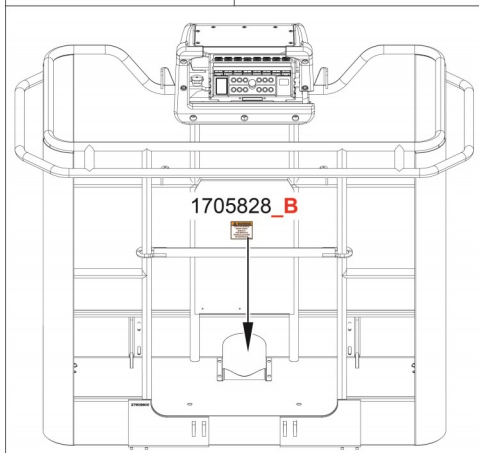
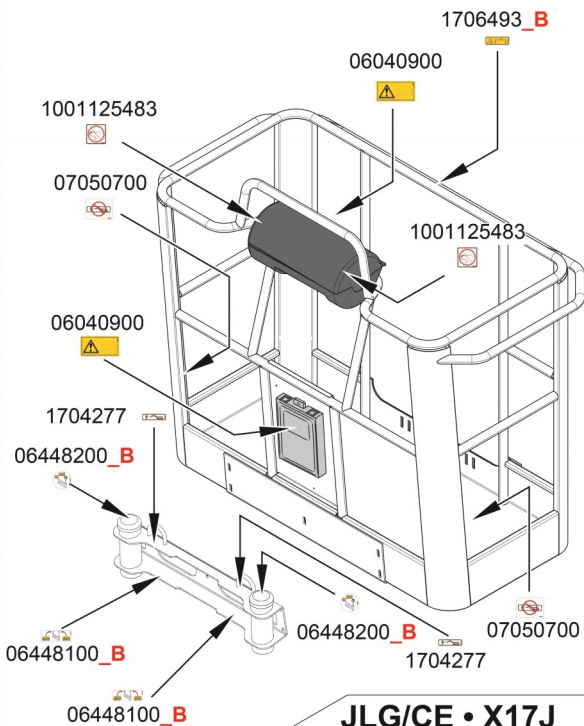
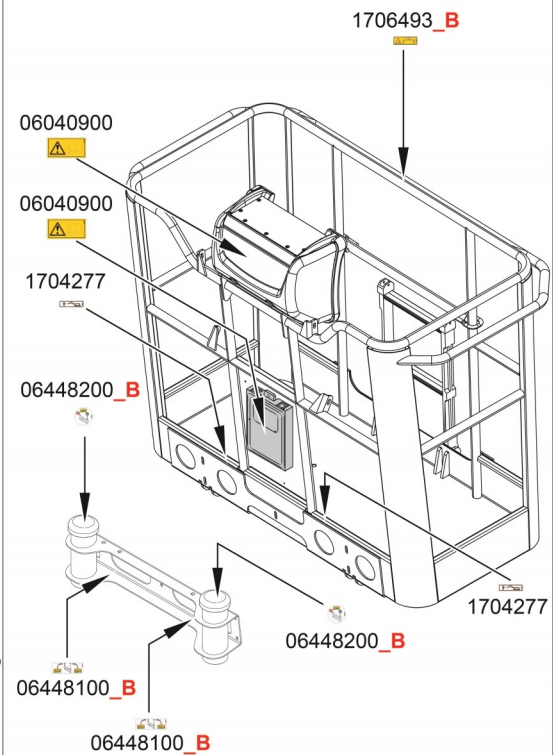
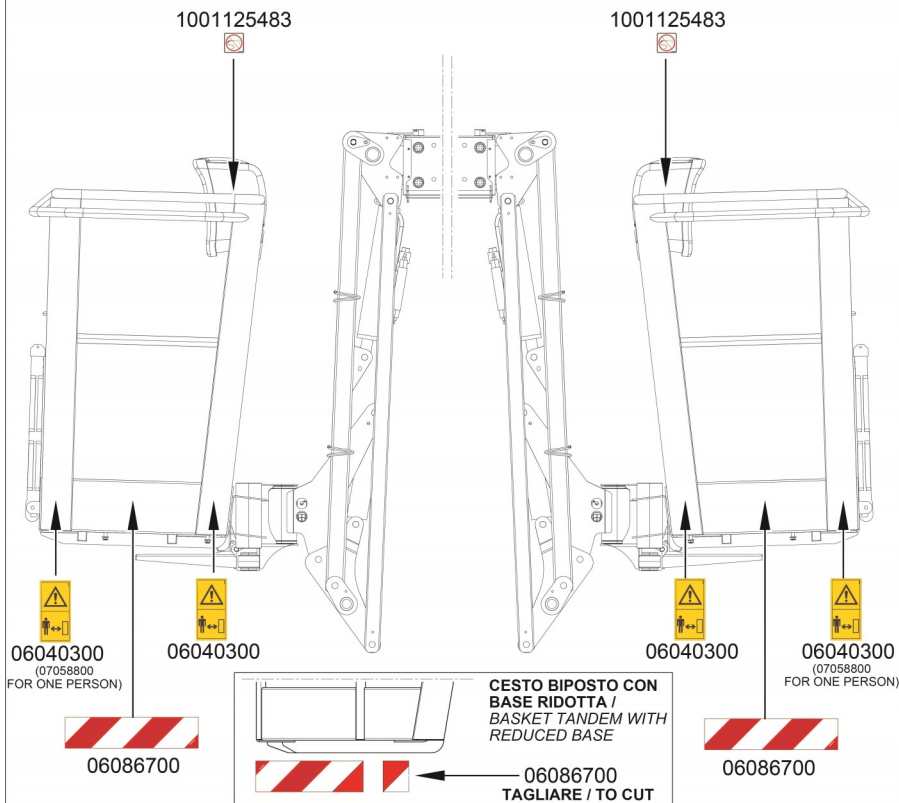

JLG/CE • X17J

KIT ADESIVI CESTO / ADHESIVE KIT BASKET / AUTOCOLLANTS PANIER KIT / AUFKLEBER-KIT BASKET / KIT DE ETIQUETA CESTA / STICKERS KIT DE MAND VAN
X14J_X17J_X19J_X23J ... X13JPLUS_X15JPLUS_X17JPLUS_X20JPLUS_X26JPLUS

SCALA 1:8 COD. 17878600 TAV. 01 A1

P Kit portata cesto L Kit adesivi in lingua

SERIE / SERIES JLG /CE COD. 178768 POSIZIONE ADESIVI PORTATA CESTO /POSITION ADHESIVE**

POS.	COD.	REV.	DESCRIZIONE / DESCRIPTION	Q.tà
P1	178768X14J		KIT ADESIVI PORTATA CESTO X14J CON MOTORE TERMICO E LITHIUM	
	07059400	A	ADESIVO JLG PORTATA CESTO 2 PERSONE X14J L=135X145 MM	01
	07059300	A	ADESIVO JLG PORTATA CESTO 1 PERSONA X14J L=135X145 MM	01
P1	178768X17J		KIT ADESIVI PORTATA CESTO X17J CON MOTORE TERMICO E LITHIUM	
	07059600	A	ADESIVO JLG PORTATA CESTO 2 PERSONE X17J L=135X145 MM	01
	07059500	A	ADESIVO JLG PORTATA CESTO 1 PERSONA X17J L=135X145 MM	01
P1	178768X19J		KIT ADESIVI PORTATA CESTO X19J CON MOTORE TERMICO E LITHIUM	
	07059800	A	ADESIVO JLG PORTATA CESTO 2 PERSONE X19J L=135X145 MM	01
	07059700	A	ADESIVO JLG PORTATA CESTO 1 PERSONA X19J L=135X145 MM	01
P1	178768X23J		KIT ADESIVI PORTATA CESTO X23J CON MOTORE TERMICO E LITHIUM	
	07060000	A	ADESIVO JLG PORTATA CESTO 2 PERSONE X23J L=135X145 MM	01
	07059900	A	ADESIVO JLG PORTATA CESTO 1 PERSONA X23J L=135X145 MM	01
P1	178768X13JP		KIT ADESIVI PORTATA CESTO X13JPLUS CON MOTORE TERMICO E LITHIUM	
	07868200	A	ADESIVO JLG PORTATA CESTO 2 PERSONE X13JPLUS L=135X145 MM	01
	07868400	A	ADESIVO JLG PORTATA CESTO 1 PERSONA X13JPLUS L=135X145 MM	01
P1	178768X15JP		KIT ADESIVI PORTATA CESTO X15JPLUS CON MOTORE TERMICO E LITHIUM	
	07799400	A	ADESIVO JLG PORTATA CESTO 2 PERSONE X15JPLUS L=135X145 MM	01
	07799500	A	ADESIVO JLG PORTATA CESTO 1 PERSONA X15JPLUS L=135X145 MM	01

SERIE / SERIES JLG / CE COD. 178768 POSIZIONE ADESIVI IN LINGUA / POSITION LANGUAGE STICKERS**

POS.	COD.	REV.	DESCRIZIONE / DESCRIPTION	Q.tà
	178768IT		ADESIVI IN LINGUA PER KIT CESTO SERIE JLG/CE X13_X15_X17_X20_X26 - ITALIANO	
L1	06555300	C	ADESIVO USO PIATTAFORMA AEREA CINGOLATA - ITALIANO L=128X230_MOD_C	01
L2	07188100	A	ADESIVO JLG-CE RICARICARE LE BATTERIE DOPO L'USO ALMENO OGNI 3 MESI - ITALIANO L=50x50 MM	01
	178768GB		ADESIVI IN LINGUA PER KIT CESTO SERIE JLG/CE X13_X15_X17_X20_X26 - INGLESE	
L1	06562600	C	ADESIVO USO PIATTAFORMA AEREA CINGOLATA - INGLESE L=128X230_MOD_C	01
L2	07202100	A	ADESIVO JLG-CE RICARICARE LE BATTERIE DOPO L'USO ALMENO OGNI 3 MESI - INGLESE L=50x50 MM	01
	178768FR		ADESIVI IN LINGUA PER KIT CESTO SERIE JLG/CE X13_X15_X17_X20_X26 - FRANCESE	
L1	06562700	C	ADESIVO USO PIATTAFORMA AEREA CINGOLATA - FRANCESE L=128X230_MOD_C	01
L2	07202200	A	ADESIVO JLG-CE RICARICARE LE BATTERIE DOPO L'USO ALMENO OGNI 3 MESI - FRANCESE L=50x50 MM	01
	178768DE		ADESIVI IN LINGUA PER KIT CESTO SERIE JLG/CE X13_X15_X17_X20_X26 - TEDESCO	
L1	06562800	C	ADESIVO USO PIATTAFORMA AEREA CINGOLATA - TEDESCO L=128X230_MOD_C	01
L2	07188200	A	ADESIVO JLG-CE RICARICARE LE BATTERIE DOPO L'USO ALMENO OGNI 3 MESI - TEDESCO L=50x50 MM	01
	178768ES		ADESIVI IN LINGUA PER KIT CESTO SERIE JLG/CE X13_X15_X17_X20_X26 - SPAGNOLO	
L1	06562900	C	ADESIVO USO PIATTAFORMA AEREA CINGOLATA - SPAGNOLO L=128X230_MOD_C	01
L2	07202300	A	ADESIVO JLG-CE RICARICARE LE BATTERIE DOPO L'USO ALMENO OGNI 3 MESI - SPAGNOLO L=50x50 MM	01
	178768NL		ADESIVI IN LINGUA PER KIT CESTO SERIE JLG/CE X13_X15_X17_X20_X26 - OLANDESE	
L1	06563000	C	ADESIVO USO PIATTAFORMA AEREA CINGOLATA - OLANDESE L=128X230_MOD_C	01
L2	07188300	A	ADESIVO JLG-CE RICARICARE LE BATTERIE DOPO L'USO ALMENO OGNI 3 MESI - OLANDESE L=50x50 MM	01

SERIE / SERIES JLG / CE COD. 178768 POSIZIONE ADESIVI IN LINGUA / POSITION LANGUAGE STICKERS**

POS.	COD.	REV.	DESCRIZIONE / DESCRIPTION	Q.tà
	178768SW		ADESIVI IN LINGUA PER KIT CESTO SERIE JLG/CE X13_X15_X17_X20_X26 - SVEDESE	
L1	07137300	C	ADESIVO USO PIATTAFORMA AEREA CINGOLATA - SVEDESE L= 128X230 MM _MOD_C	01
L2	07188400	A	ADESIVO JLG-CE RICARICARE LE BATTERIE DOPO L'USO ALMENO OGNI 3 MESI - SVEDESE L=50x50 MM	01
	178768PT		ADESIVI IN LINGUA PER KIT CESTO SERIE JLG/CE X13_X15_X17_X20_X26 - PORTOGHESE	
L1	06563100	C	ADESIVO USO PIATTAFORMA AEREA CINGOLATA - PORTOGHESE L=128X230 _MOD_C	01
L2	07202400	A	ADESIVO JLG-CE RICARICARE LE BATTERIE DOPO L'USO ALMENO OGNI 3 MESI - PORTOGHESE L=50x50 MM	01
	178768DA		ADESIVI IN LINGUA PER KIT CESTO SERIE JLG/CE X13_X15_X17_X20_X26 - DANESE	
L1	07138100	C	ADESIVO USO PIATTAFORMA AEREA CINGOLATA - DANESE L= 128X230 MM _MOD_C	01
L2	07188500	A	ADESIVO JLG-CE RICARICARE LE BATTERIE DOPO L'USO ALMENO OGNI 3 MESI - DANESE L=50x50 MM	01
	178768NO		ADESIVI IN LINGUA PER KIT CESTO SERIE JLG/CE X13_X15_X17_X20_X26 - NORVEGESE	
L1	07162000	C	ADESIVO USO PIATTAFORMA AEREA CINGOLATA - NORVEGESE L=128X230 MM _MOD_C	01
L2	07188600	A	ADESIVO JLG-CE RICARICARE LE BATTERIE DOPO L'USO ALMENO OGNI 3 MESI - NORVEGESE L=50x50 MM	01
	178768RU		ADESIVI IN LINGUA PER KIT CESTO SERIE JLG/CE X13_X15_X17_X20_X26 - RUSSO	
L1	07514800	A	ADESIVO USO PIATTAFORMA AEREA CINGOLATA - RUSSO L=128X230 MM	01
L2	07910300	A	ADESIVO JLG-CE RICARICARE LE BATTERIE DOPO L'USO ALMENO OGNI 3 MESI - RUSSO L=50x50 MM	01
	178768PL		ADESIVI IN LINGUA PER KIT CESTO SERIE JLG/CE X13_X15_X17_X20_X26 - POLACCO	
L1	07506600	B	ADESIVO USO PIATTAFORMA CINGOLATA LINGUA POLACCO L= 128X230MM _MOD_B	01
L2	07508100	A	ADESIVO JLG-CE RICARICARE LE BATTERIE DOPO L'USO ALMENO OGNI 3 MESI - POL ACCO L=50x50 MM	01

KIT INTEGRAZIONE ADESIVI
CESTO RETTANGOLARE DSE

DECALS KIT INTEGRATION
RECTANGULAR DSE BASKET

18374500

HISTORY REVISION

DATA/DATE	VERSION	MODIFICHE/CHANGES	AUTORE
01/04/2021	1.0	Realizzata nuova versione senza foto. New version without photos.	Masaggia Mattia

LISTA ADESIVI
DECALS LIST

CODE	DESCRIZIONE	QTA'
07058800	ADESIVO PERICOLO MANTENERE LE DISTANZE L=65X130 MM - GIALLO	2,00
08141300	ADESIVO NEW LOGO HINOWA GRAFFIATO H=40mm L=100mm	1,00
08347400	ADESIVO STRISCIA BIANCA E ROSSA H100 X L220 MM	2,00
08347500	ADESIVO STRISCIA BIANCA E ROSSA H100 X L350 MM	2,00
08318500	ADESIVO PRESPAZIATO CESTO DSE NERO	1,00

VEDI
MODELLO
MACCHINA

06040900

07878400

06040400

VEDI
MODELLO
MACCHINA

08141300

06448100

06448200

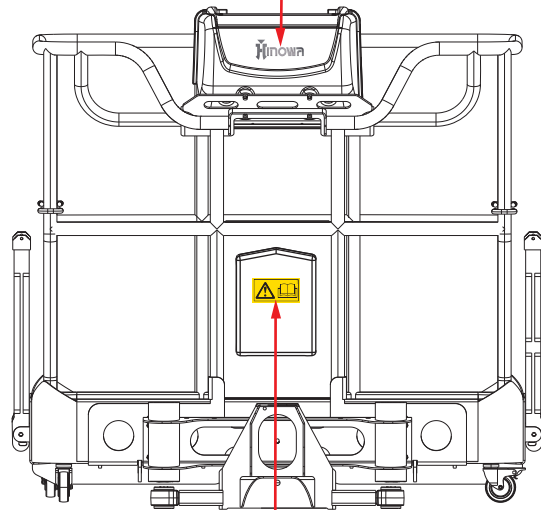
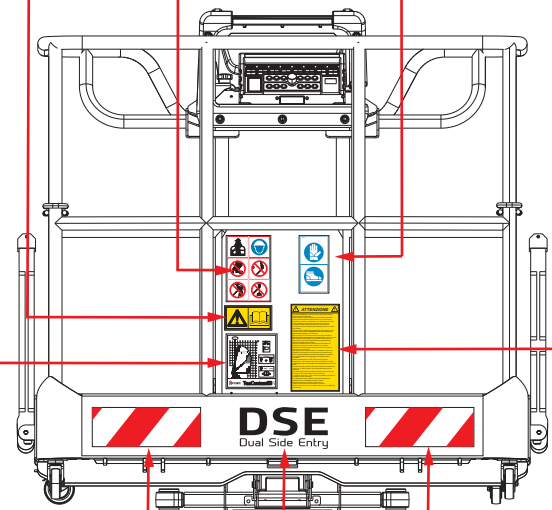

08347500 08318500 08347500

06040900

06448200

06448100

1001125483

1001125483

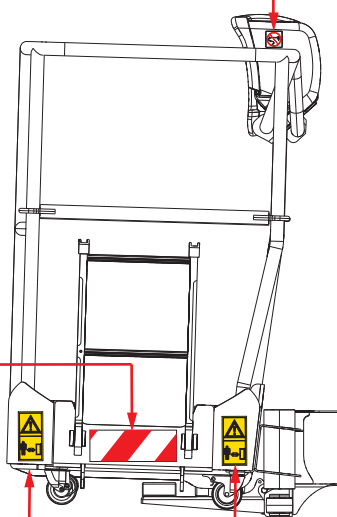
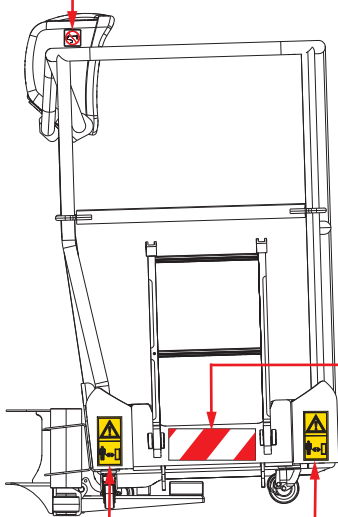

1704277

1704277

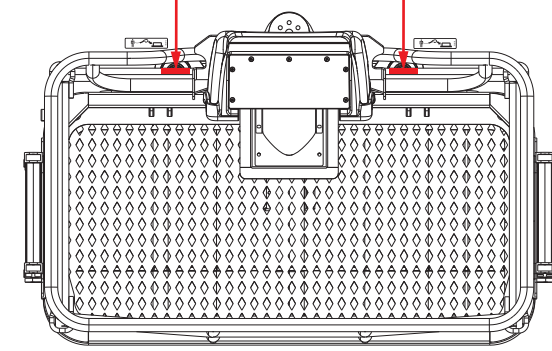

07058800

08347400

07058800

KIT INTEGRAZIONE ADESIVI
CESTO RETTANGOLARE DSE ANSI

DECALS INTEGRATION KIT
DSE RECTANGULAR BASKET ANSI

18486500

HISTORY REVISION

DATA/DATE	VERSION	MODIFICHE/CHANGES	AUTORE
24/01/2022	1.0	Realizzato nuovo KIT New KIT made	Masaggia Mattia

LISTA ADESIVI IN KIT CODE. 18486500**DECALS LIST KIT CODE 18486500**

POS	CODE			DESCRIZIONE DESCRIPTION	QTA QTY
	ENGLISH	FRENCH	PORTUGUESE		
L20	1706385	07118900	07123500	ADESIVO JLG SCORRIMENTO SBARRA CHIUSURA CESTO - ING L=184,15X25,4 MM_MOD_C	01

CODE	DESCRIPTION	QTY
1701640	ADESIVO JLG LEGGERE IL MANUALE L= 69,85x69,85 MM	01
08347500	ADESIVO STRISCIA BIANCA E ROSSA H100 X L350 MM	02
08347400	ADESIVO STRISCIA BIANCA E ROSSA H100 X L220 MM	02
07690100	ADESIVO JLG - LOGO JLG PER CESTO COLORE GRIGIO PANTONE 432C L=300x104,2 MM	01

LISTA ADESIVI CESTO COMPLETO COMPLETE BASKET DECALS LIST						
POS	CODE			DESCRIZIONE DESCRIPTION	QTA QTY	
	ENGLISH	FRENCH	PORTUGUESE			
L1	07056100	07116800	07121400	ADESIVO JLG PERICOLO SCHIACCIAMENTO - ING L= 140x60,71 MM	04	
L2	1706387	07119100	07123700	ADESIVO JLG PERICOLO SCHIACCIAMENTO - ING L=177,80x69,85 MM (SUL CESTO)	01	
L4	1702868	07117800	07122400	ADESIVO JLG PERICOLO SCHIACCIAMENTO MANO - ING L= 241,30X25.40 MM_MOD_B (**)	01	
L6	1706386	071190000	07123600	ADESIVO JLG PERICOLO CADUTE - ING L=196,85x76,2 MM	01	
L7	07051100	07116700	07121300	ADESIVO JLG PERICOLO CADUTA - RIPRISTINARE I TAPPI - ING L=196,5x35 MM_MOD_B	01	
L8	07051000	07116600	07121200	ADESIVO JLG ATTENZ.CADUTE - SBLOCCARE SOLO NEI CASI PREVISTI - ING D Ø 60 FORO 4 MM (**)	02	
L9	1706133	07118700	07123300	ADESIVO JLG PERICOLO RIBALTAMENTO - ING L=139,7X68,85 MM_MOD_C	01	
L10	07058600	07117200	07121800	ADESIVO JLG POSIZIONE STABILIZZATORI X700 - ING L=139,7X68,85 MM	01	
L16	1706128	07118600	07123200	ADESIVO JLG PERICOLO FOLGORAZIONE - ING L=120,65x91,50 MM_MOD_E	01	
L19	081081GB	081081FR	081081PT	ADESIVO JLG/ANSI CARICO MAX IN CESTA 2 PERSONE X1000AJ - ING L=196,85x76,2 MM (INGLESE)	01	
L20	1706385	07118900	07123500	ADESIVO JLG SCORRIMENTO SBARRA CHIUSURA CESTO - ING L=184,15X25,4 MM_MOD_C	02	
L21	08069800			ADESIVO JLG ATTENZIONI PROP.65 L=101,6x57,1 MM RIF JLG CODE. 1001231801 C	01	

ADESIVI NON IN LINGUA / DECALS NOT IN LANGUAGE		
CODE	DESCRIPTION	QTY
1701640	ADESIVO JLG LEGGERE IL MANUALE L= 69,85x69,85 MM	02
08347500	ADESIVO STRISCIA BIANCA E ROSSA H100 X L350 MM	02
08347400	ADESIVO STRISCIA BIANCA E ROSSA H100 X L220 MM	02
1704277	DECAL,LANYARD ATTACH	02
07690100	ADESIVO JLG - LOGO JLG PER CESTO COLORE GRIGIO PANTONE 432C L=300x104,2 MM	01
1001125483	ADESIVO JLG VIETATO LAVARE L=63,5X63,5 MM	02

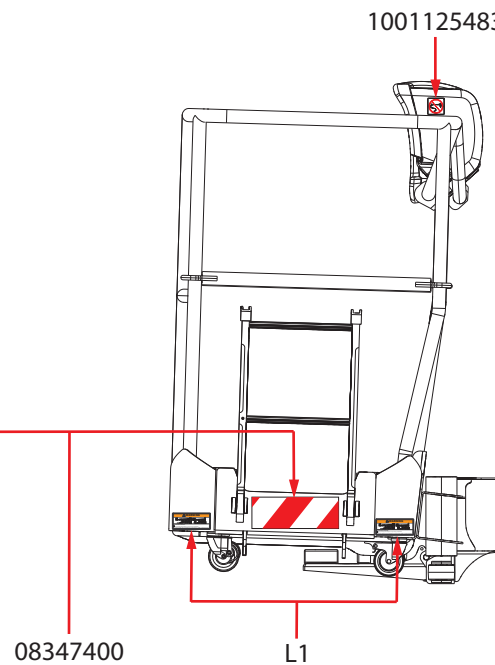
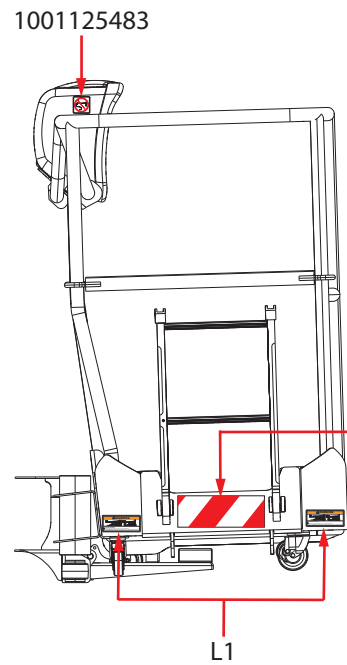
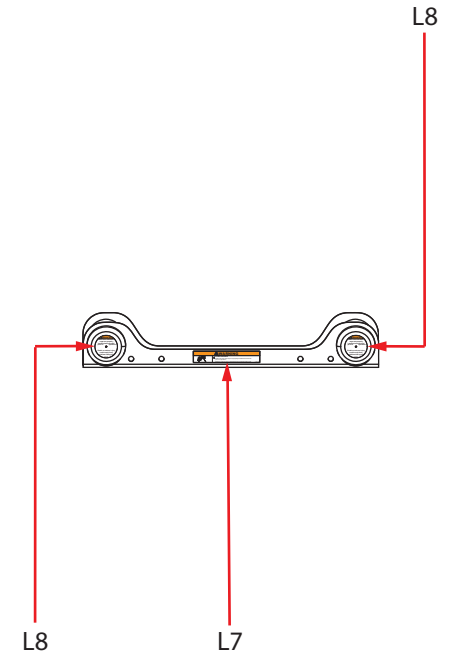
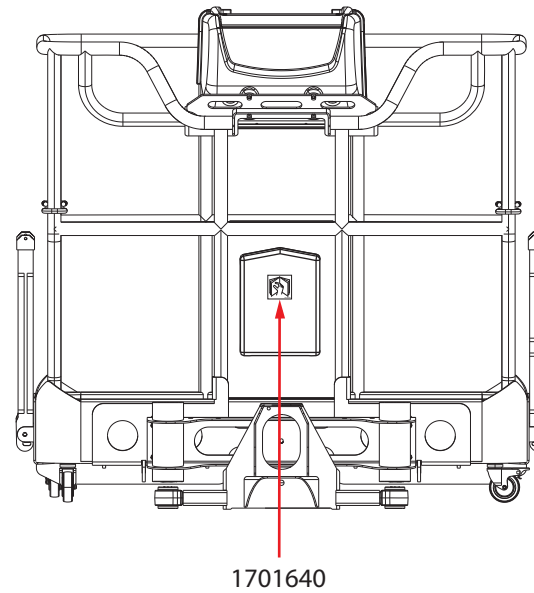
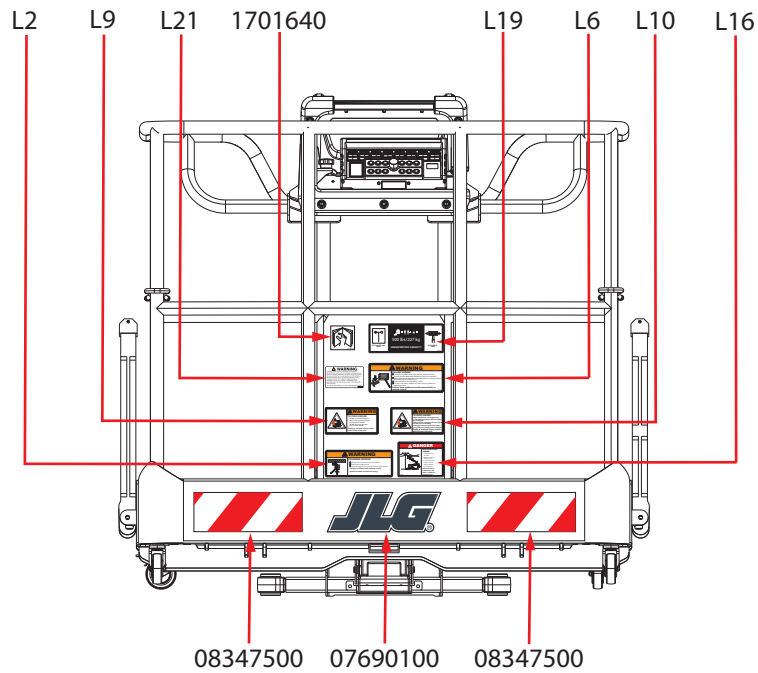

08347400



TABELLA PERNI/SPINE (PINS TABLE)

LOCKING SYSTEM
GHIERA
(LOCKNUTS CODE)
REF. TABLE BELOW



PERNO/SPINA (PIN)

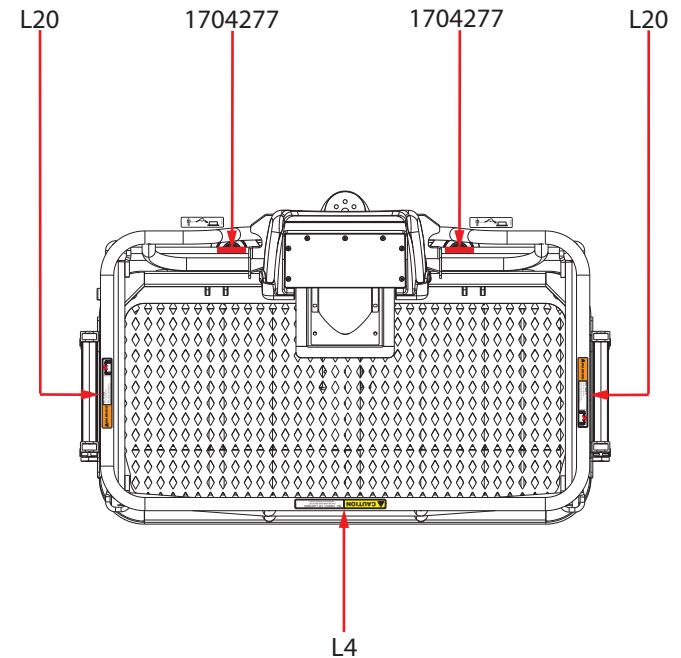
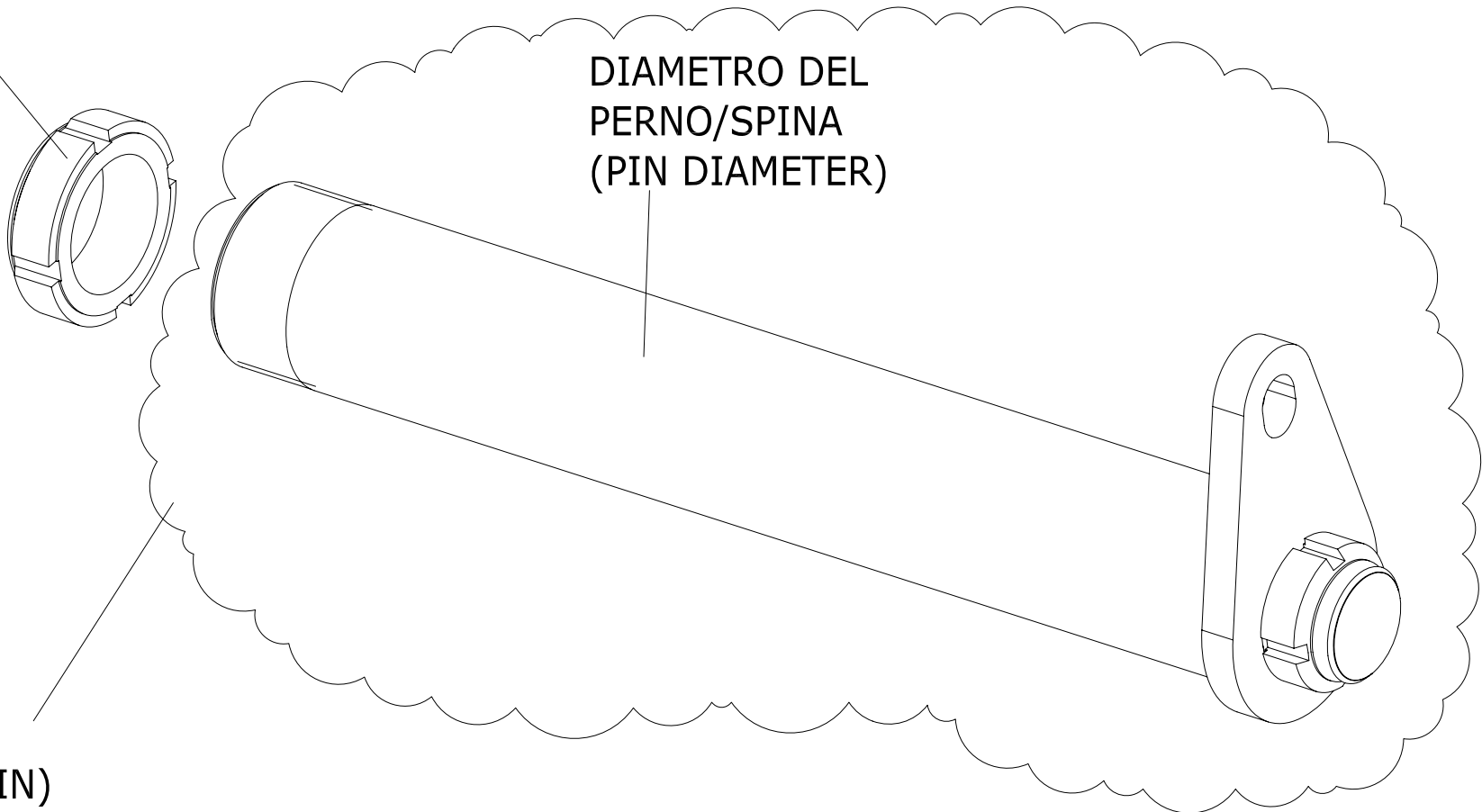



IL CODICE DEL PERNO A RICAMBIO COMPRENDE LA GOCCIA MONTATA E LA GHIERA DI FISSAGGIO DELLA GOCCIA

THE CODE OF A PIN INCLUDES DROP PARTS MOUNTED AND THE LOCK NUT TO FIXING THE DROP,
ALL THESE PARTS ARE SHIPPED ALREADY MOUNTED TOGETHER

DIAMETRO DEL PERNO/SPINA mm SISTEMA METRICO (PIN DIAMETER mm METRIC)	GHIERA (LOCKNUTS CODE)	DADO (NUTS CODE)
25	BG4	
30	BG5	
35	BG3	
40	BG2	
45	BG7	
50	BG8	
20 (DIAMETER OF THREADED PART M17 PITCH=1)	BG1	
20 (DIAMETER OF THREADED PART M20 PITCH=1)	BG6	
20 (DIAMETER OF THREADED PART M20 PITCH=1,5)	BG12	

07825700	BUSSOLA PER GHIERE S12GU
07825800	BUSSOLA PER GHIERE S17GU
07825900	BUSSOLA PER GHIERE S20GU
07826000	BUSSOLA PER GHIERE S25GU
07826100	BUSSOLA PER GHIERE S30GU
07826200	BUSSOLA PER GHIERE S35GU
07826300	BUSSOLA PER GHIERE S40GU
07826400	BUSSOLA PER GHIERE S45GU
07826500	BUSSOLA PER GHIERE S50GU
07826600	BUSSOLA PER GHIERE S55GU
07826700	BUSSOLA PER CHIARE S65GU

POS	Codice	U.M.	 Descrizione	 Description	 Designation	 Benennung	 Descripción
BC1	BC000100	NR	COPPIGLIA 4X40	COTTER PIN 4X40	GOUPILLE 4X40	SPLINT 4X40	CLAVIJA 4X40
BC2	BC000200	NR	COPPIGLIA 5X40	COTTER PIN 5X40			
BC3	BC000300	NR	SEEGER ESTERNO Ø20 GEOMET	SEEGER EXTERNAL Ø20 GEOMET	SEGER EXTERNE Ø20 GEOMET	EXTERNEN SEGER Ø20 GEOMET	SEGER ESTERNO Ø20 GEOMET
BC4	BC000400	NR	SEEGER ESTERNO Ø8	SEEGER EXTERNAL Ø8	CIRCLIP	RING	ANILLO
BC5	BC000500	NR	SEEGER ESTERNO Ø25 GEOMET	SEEGER EXTERNAL Ø25 GEOMET	SEEGER CIRCLIP	SEEGERRING	ANILLO DE RETENCIÓN SEEGER
BC6	BC000600	NR	COPPIGLIA 1,8X8	COTTER PIN 1,8X8			
BC7	BC000700	NR	COPPIGLIA 4X55	COTTER PIN 4X55	GOUPILLE 4X55	SPLINT 4X55	CLAVIJA 4X55
BC8	BC000800	NR	SEEGER ESTERNO Ø15	SEEGER EXTERNAL Ø15	CIRCLIP	RING	ANILLO
BC9	BC000900	NR	SEEGER ESTERNO Ø30	SEEGER EXTERNAL Ø30	CIRCLIP	RING	ANILLO
BC11	BC001100	NR	ANELLI ELASTICI X ALBERI (SEEGER) DIN 471 ACC.MOLLE 10 ZINCATA D. BIANCA	SNAP RINGS FOR SHAFTS (SEEGER) DIN 471 ACC. SPRINGS 10 Z WITHE	CIRCLIP	RING	ANILLO
BC12	BC001200	NR	ANELLI ELASTICI X ALBERI (SEEGER) DIN 471 ACC.MOLLE 12 GEO 321A	SNAP RINGS FOR SHAFTS (SEEGER) DIN 471 ACC. SPRINGS 12 GEO 321A	CIRCLIP	RING	ANILLO
BC13	BC001300	NR	ANELLI ELASTICI X FORI (SEEGER) DIN 472 ACC.MOLLE 33 GEO 321A	SNAP RINGS FOR HOLES (SEEGER) DIN 472 ACC. SPRINGS 33 GEO 321A	CIRCLIP	RING	ANILLO
BC14	BC001400	NR	ANELLI ELASTICI X FORI (SEEGER) DIN 472 ACC.MOLLE 62 GEO 321A	SNAP RINGS FOR HOLES (SEEGER) DIN 472 ACC. SPRINGS 62 GEO 321A	CIRCLIP	RING	ANILLO
BC15	BC001500	NR	ANELLI ELASTICI X FORI (SEEGER) DIN 472 ACC.MOLLE 75 GEO 321A	SNAP RINGS FOR HOLES (SEEGER) DIN 472 ACC. SPRINGS 75 GEO 321A	CIRCLIP	RING	ANILLO
BC16	BC001600	NR	COPIGLIA RICOTTA DIN 94 FERRO RICOTTO D 5 X 70 Z.BIANCA	COTTER PIN DIN 94 IRON ANNEALED D 5 X 70 Z. WHITE	CIRCLIP	RING	ANILLO

POS	Codice	U.M.	 Descrizione	 Description	 Designation	 Benennung	 Descripción
BC17	BC001700	NR	COPIGLIA ELASTICA DI SICUREZZA ACC.MOLLE D 2 Z.BIANCA	ELASTIC COTTER PIN ACC. SPRINGS D 2 Z. WHITE	CIRCLIP	RING	ANILLO
BC18	BC001800	NR	ANELLI ELASTICI X ALBERI (SEEGER) DIN 471 ACC.MOLLE 35 GEO 321A	SNAP RINGS FOR SHAFTS (SEEGER) DIN 471 ACC. SPRINGS 35 GEO 321A	CIRCLIP	RING	ANILLO
BC19	BC001900	NR	ANELLI ELASTICI X ALBERI (SEEGER) DIN 471 ACC.MOLLE 70 GEO 321A	SNAP RINGS FOR SHAFTS (SEEGER) DIN 471 ACC. SPRINGS 70 GEO 321A	CIRCLIP	RING	ANILLO
BC20	BC002000	NR	COPIGLIA RICOTTA DIN 94 FERRO RICOTTO D 5 X 50 Z.BIANCA	COTTER PIN DIN 94 IRON ANNEALED D 5 X 50 Z. WHITE	CIRCLIP	RING	ANILLO
BC21	BC002100	NR	ANELLI ELASTICI X FORI (SEEGER) DIN 472 ACC.MOLLE 55 GEO 321A	SNAP RINGS FOR HOLES (SEEGER) DIN 472 ACC. SPRINGS 55 GEO 321A	CIRCLIP	RING	ANILLO
BD1	BD000100	NR	DADO ESAGONALE FLANGIATO LISCIO PG DIN 6923 CL 8 M 14 Z.BIANCA	HEX FLANGE NUT DIN 6923 CL SMOOTH PG 8 M 14 Z. WHITE	ÉCROU HEXAGONAL BRIDÉ LISSE PG DIN 6923 CL 8 M 14 Z.BLANCHE	GEWINDE SECHSKANTMUTTER DIN 6923 CL SMOOTH PG 8 M 14 Z. WEIß	ARANDELA HEXAGONAL ROSCADA LISA DIN 6923 CL 8 M 14 GALVANIZADA BLANCA
BD2	BD000200	NR	DADO ESAGONALE BASSO PG DIN 936 CL 04 M 8 Z.BIANCA	LOW HEX NUT DIN 936 PG 04 M CL 8 Z. WHITE	ÉCROU HEXAGONAL BAS PG DIN 936 CL 04 M 8 GALVANISÉ BLANC	NUTTER	TUERCA
BD3	BD000300	NR	DADO ESAGONALE ALTO PG UNI 5587 CL 8 M 8 Z.BIANCA	HEX NUT HIGH PG UNI 5587 CL 8 M 8 Z. WHITE	ÉCROU HEXAGONAL PG UNI 5587 CL 8 M 8 Z.BLANCHE	HOHE SECHSKANTMUTTER PG UNI 5587 CL 8 M 8 Z. WEIß	ARANDELA ALTA HEXAGONAL UNI 5587 CL 8 M 8 GALVANIZADA BLANCA
BD4	BD000400	NR	DADO ALTO AUTOBLOCCANTE PG DIN 982 CL 8 M 12 Z.BIANCA	HIGH SELF LOCKING NUT DIN 982 PG 12 CL 8 M Z. WHITE	HAUT ÉCROU AUTOBLOQUANT DIN 982 PG 12 CL 8 M Z. BLANCHE	HOHE SELBSTSICHERUNGSMUTTER DIN 982 PG 12 CL 8 M Z. WEIß	ARANDELA ALTA AUTOBLOCANTE DIN 982 CL 8 M 12 GALVANIZADA BLANCA
BD5	BD000500	NR	DADO ALTO AUTOBLOCCANTE PG DIN 982 CL 8 M 8 Z.BIANCA	HIGH SELF LOCKING NUT DIN 982 PG CL 8 M 8 Z. WHITE	HAUT ÉCROU AUTOBLOQUAND DIN 982 PG CL 8 M 8 Z. BLANCHE	HOHE SELBSTSICHERUNGSMUTTER DIN 982 PG CL 8 M 8 Z. WEIß	ARANDELA ALTA AUTOBLOCANTE DIN 982 CL 8 M 8 GALVANIZADA BLANCA
BD6	BD000600	NR	DADO ESAGONALE ALTO PG UNI 5587 CL 8 M 4 Z.BIANCA	HEX NUT HIGH PG UNI 5587 M 4 CL 8 Z. WHITE	ÉCROU HEXAGONAL HAUT PG UNI 5587 CL 8 M 4 GALVANISÉ BLANC	NUTTER	TUERCA

POS	Codice	U.M.	 Descrizione	 Description	 Designation	 Benennung	 Descripción
BD7	BD000700	NR	DADO ESAGONALE BASSO PG DIN 936 CL 04 M 6 Z.BIANCA	LOW HEX NUT DIN 936 PG 6 CL 04 M Z. WHITE	ÉCROU BAS HEXAGONAL DIN 936 PG 6 CL 04 M Z. BLANCHE	NIEDRIGE SECHSKANTMUTTER DIN 936 PG 6 CL 04 M Z. WEIß	ARANDELA BAJA HEXAGONAL DIN 936 CL 04 M 6 GALVANIZADA BLANCA
BD8	BD000800	NR	DADO BASSO AUTOBLOCCANTE PG DIN 985 CL 8 M 6 Z.BIANCA	LOW SELF-LOCKING NUT DIN 985 PG 6 CL 8 M Z. WHITE	ÉCROU BAS AUTOBLOQUANT DIN 985 PG 6 CL 8 M Z. BLANCHE	NIEDRIGE SELBSTSICHERUNGSMUTTER DIN 985 PG 6 CL 8 M Z. WEIß	ARANDELA BAJA AUTOBLOCANTE DIN 985 CL 8 M 6 GALVANIZADA BLANCA
BD9	BD000900	NR	DADO ALTO AUTOBLOCCANTE PG DIN 982 CL 8 M 6 Z.BIANCA	HIGH SELF LOCKING NUT DIN 982 PG CL 8 M6 Z. WHITE	ÉCROU HAUT AUTOBLOQUANT NUT DIN 982 PG CL 8 M6 Z. BLANCHE	SELBSTSICHERUNGSMUTTER DIN 982 PG CL 8 M6 Z. WEIß	TUERCA AUTOBLOCANTE ALTA DIN 982 CL 8 M 6 GALVANIZADA BLANCA
BD10	BD001000	NR	DADO BASSO AUTOBLOCCANTE PG DIN 985 CL 8 M 5 Z.BIANCA	LOW SELF-LOCKING NUT DIN 985 PG CL 8 M5 Z. WHITE	ÉCROU BAS AUTOBLOQUANT PG DIN 985 CL 8 M 5 GALVANISÉ BLANC	NUTTER	TUERCA
BD11	BD001100	NR	DADO ALTO AUTOBLOCCANTE PG DIN 982 CL 8 M 5 Z.BIANCA	HIGH SELF LOCKING NUT DIN 982 PG CL 8 M5 Z. WHITE	ÉCROU HAUT AUTOBLOQUANT PG DIN 982 CL 8 M 5 Z.BLANCHE	SELBSTSICHERUNGSMUTTER DIN 982 PG CL 8 M5 Z. WEIß	TUERCA AUTOBLOCANTE ALTA PG DIN 982 CL 8 M 5 GALVANIZADA BLANCA
BD12	BD001200	NR	DADO ALTO AUTOBLOCCANTE PG DIN 982 CL 8 M 4 Z.BIANCA	HIGH SELF LOCKING NUT DIN 982 PG CL 8 M4 Z. WHITE	ÉCROU HAUT AUTOBLOQUANT PG DIN 982 CL 8 M 4 Z.BLANCHE	SELBSTSICHERUNGSMUTTER DIN 982 PG CL 8 M4 Z. WEIß	TUERCA ALTA AUTOBLOCANTE PG DIN 982 CL 8 M 4 GALVANIZADO BLANCA
BD13	BD001300	NR	DADO ALTO AUTOBLOCCANTE PG DIN 982 CL 8 M 3 Z.BIANCA	HIGH SELF LOCKING NUT DIN 982 PG CL 8 M3 Z. WHITE	ÉCROU HAUT AUTOBLOQUANT PG DIN 982 CL 8 M 3 GALVANISÉ BLANC	NUTTER	TUERCA
BD14	BD001400	NR	DADO ALTO AUTOBLOCCANTE PF DIN 982 CL 8 M 20 X 1,5 Z.BIANCA	HIGH SELF LOCKING NUT DIN 982 PF CL 8 M 20 X 1.5 Z WHITE	ÉCROU HAUT AUTOBLOQUANT PF DIN 982 CL 8 M 20 X 1,5 Z.BLANCHE	SELBSTSICHERUNGSMUTTER DIN 982 PF CL 8 M 20 X 1.5 Z WEIß	TUERCA AUTOBLOCANTE ALTA DIN 982 CL 8 M 20 X 1,5 GALVANIZADA BLANCA
BD15	BD001500	NR	DADO ALTO AUTOBLOCCANTE PG DIN 982 CL 8 M 10 Z.BIANCA	HIGH SELF LOCKING NUT DIN 982 PG CL 8 M10 Z. WHITE	ÉCROU HAUT AUTOBLOQUANT DIN 982 PG CL 8 M10 Z. BLANCHE	SELBSTSICHERUNGSMUTTER DIN 982 PG CL 8 M10 Z. WEIß	TUERCA AUTOBLOCANTE ALTA DIN 982 CL 8 M 10 GALVANIZADA BLANCA
BD16	BD001600	NR	DADO ESAGONALE ALTO PG UNI 5587 CL 8 M 3 Z.BIANCA	HEX NUT HIGH PG UNI 5587 CL 8 M3 Z. WHITE	ÉCROU HEXAGONAL HAUT PG UNI 5587 CL 8 M 3 GALVANISÉ BLANC	NUTTER	TUERCA
BD17	BD001700	NR	DADO BASSO AUTOBLOCCANTE PG DIN 985 CL 8 M 8 Z.BIANCA	LOW SELF-LOCKING NUT DIN 985 PG CL 8 M8 Z. WHITE	ÉCROU BAS AUTOBLOQUANT PG DIN 985 CL 8 M 8 Z.BLANCHE	SELBSTSICHERUNGSMUTTER DIN 985 PG CL 8 M8 Z. WEIß	TUERCA BAJA AUTOBLOCANTE DIN 985 CL 8 M 8 GALVANIZADA BLANCA

POS	Codice	U.M.	 Descrizione	 Description	 Designation	 Benennung	 Descripción
BD18	BD001800	NR	DADO ALTO AUTOBLOCCANTE PG DIN 982 CL 8 M 16 Z.BIANCA	HIGH SELF LOCKING NUT DIN 982 PG CL 8 M16 Z. WHITE	ÉCROU AUTOBLOQUANT PG DIN 982 CL 8 M 16 GALVANISÉ BLANC	NUTTER	TUERCA
BD22	BD002200	NR	DADO ALTO AUTOBLOCCANTE PG DIN 982 CL 8 M 14 Z.BIANCA	HEX FLANGE NUT DIN 982 CL 8 M 14 Z. WHITE	ÉCROU HAUT AUTOBLOQUANT PG DIN 982 CL 8 M 14 Z.BLANCHE	SELBSTSICHERUNGSMUTTER DIN 982 CL 8 M 14 Z. WEIß	TUERCA ALTA AUTOBLOCANTE 982 CL 8 M 14 GALVANIZADA BLANCA
BD23	BD002300	NR	DADO BASSO AUTOBLOCCANTE PG DIN 985 CL 8 M 10 Z.BIANCA	LOW SELF-LOCKING NUT DIN 985 PG CL 8 M 10 Z. WHITE	ÉCROU BAS AUTOBLAQUANT PG DIN 985 CL 8 M 10 GALVANISÉ BLANC	NUTTER	TUERCA
BD24	BD002400	NR	DADO ALTO AUTOBLOCCANTE PG DIN 982 CL 8 M 24 Z.BIANCA	HIGH SELF LOCKING NUT DIN 982 PG CL 8 M24 Z. WHITE	ÉCROU HAUT AUTOBLOQUANT PG DIN 982 CL 8 M 24 GALVANISÉ BLANC	NUTTER	TUERCA
BD25	BD002500	NR	DADO ESAGONALE ALTO PG UNI 5587 CL 8 M 6 Z.BIANCA	HEX NUT HIGH PG UNI 5587 M 6 CL 8 Z. WHITE	ÉCROU HEXAGONAL HAUT PG UNI 5587 CL 8 M 6 Z.BLANCHE	SECHSKANTMUTTER PG UNI 5587 M 6 CL 8 Z. WEIß	TUERCA ALTA HEXAGONAL UNI 5587 CL 8 M 6 GALVANIZADA BLANCA
BD26	BD002600	NR	DADO ESAGONALE ALTO PG UNI 5587 CL 10 M 10 Z.BIANCA	HEX NUT HIGH PG UNI 5587 M 10 CL 10 Z. WHITE	ÉCROU HEXAGONAL HAUT PG UNI 5587 CL 10 M 10 Z.BLANCHE	SECHSKANTMUTTER PG UNI 5587 M 10 CL 10 Z. WEIß	TUERCA ALTA HEXAGONAL UNI 5587 CL 10 M 10 GALVANIZADA BLANCA
BD27	BD002700	NR	DADO ALTO AUTOBLOCCANTE PG DIN 982 CL 8 M 18 Z.BIANCA	HIGH SELF LOCKING NUT DIN 982 PG CL 8 M18 Z. WHITE	ÉCROU HAUT AUTOBLOQUANT PG DIN 982 CL 8 M 18 Z.BLANCHE	SELBSTSICHERUNGSMUTTER DIN 982 PG CL 8 M18 Z. WEIß	TUERCA ALTA AUTOBLOCANTE DIN 982 CL 8 M 18 GALVANIZADA BLANCA
BD28	BD002800	NR	DADO BASSO AUTOBLOCCANTE PG DIN 985 CL 8 M 16 Z.BIANCA	LOW SELF-LOCKING NUT DIN 985 PG CL 8 M 16 Z. WHITE	ÉCROU BAS AUTOBLOQUANT PG DIN 985 CL 8 M 16 GALVANISÉ BLANC	NIEDRIGE SELBSTSICHERUNGSMUTTER DIN 985 PG CL 8 M 16 Z. WEIß	TUERCA BAJA AUTOBLOCANTE PG DIN 985 CL 8 M 16 GALVANIZADA BLANCA
BD29	BD002900	NR	DADO ESAGONALE ALTO PG UNI 5587 CL 8 M 5 Z.BIANCA	HEX NUT HIGH PG UNI 5587 M 5 CL 8 Z. WHITE	ÉCROU HEXAGONAL HAUT PG UNI 5587 CL 8 M 5 Z.BLANCHE	SECHSKANTMUTTER PG UNI 5587 M 5 CL 8 Z. WEIß	TUERCA ALTA HEXAGONAL UNI 5587 CL 8 M 5 GALVANIZADA BLANCA
BD30	BD003000	NR	DADO ESAGONALE ALTO PG UNI 5587 CL 12 M 5 Z.BIANCA	HEX NUT HIGH PG UNI 5587 M 5 CL 12 Z. WHITE	ÉCROU HEXAGONAL HAUT PG UNI 5587 CL 12 M 5 Z.BLANCHE	SECHSKANTMUTTER PG UNI 5587 M 5 CL 12 Z. WEIß	TUERCA ALTA HEXAGONAL UNI 5587 CL 12 M 5 GALVANIZADA BLANCA
BD31	BD003100	NR	DADO ESAGONALE ALTO PG UNI 5587 CL 16 M 5 Z.BIANCA	HEX NUT HIGH PG UNI 5587 M 5 CL 16 Z. WHITE	ÉCROU HEXAGONAL HAUT PG UNI 5587 CL 16 M 5 Z.BLANCHE	SECHSKANTMUTTER PG UNI 5587 M 5 CL 16 Z. WEIß	TUERCA ALTA HEXAGONAL UNI 5587 CL 16 M 5 GALVANIZADA BLANCA

POS	Codice	U.M.	 Descrizione	 Description	 Designation	 Benennung	 Descripción
BD32	BD003200	NR	DADO ALTO AUTOBLOCCANTE PG DIN 982 CL 8 M 20 Z.BIANCA	HIGH SELF LOCKING NUT DIN 982 PG CL 8 M20 Z. WHITE	ÉCROU HAUT AUTOBLOQUANT PG DIN 982 CL 8 M 20 GALVANISÉ BLANC	NUTTER	TUERCA
BD33	BD003300	NR	DADO BASSO AUTOBLOCCANTE PG DIN 985 CL 8 M 12 Z.BIANCA	LOW SELF-LOCKING NUT DIN 985 PG CL 8 M 12 Z. WHITE	ÉCROU BAS AUTOBLAQUANT PG DIN 985 CL 8 M 12 GALVANISÉ BLANC	NUTTER	TUERCA
BD35	BD003500	NR	DADO ESAGONALE ALTO PG UNI 5587 CL 10 M 12 Z.BIANCA	HEXAGON NUT ALTO UNI 5587 CL 10 M 12 Z. WHITE	ÉCROU	NUTTER	TUERCA
BD36	BD003600	NR	DADO ESAGONALE ALTO PG UNI 5587 CL 10 M 16 Z.BIANCA	HEXAGON NUT ALTO UNI 5587 CL 10 M 16 Z. WHITE	ÉCROU	NUTTER	TUERCA
BD37	BD003700	NR	DADO ESAGONALE ALTO PG UNI 5587 CL 8 M 20 Z.BIANCA	HEXAGON NUT ALTO UNI 5587 CL 8 M 20 Z. WHITE	ÉCROU	NUTTER	TUERCA
BD39	BD003900	NR	DADO ALTO AUTOBLOCCANTE PG DIN 982 CL 8 M 22 Z.BIANCA	HIGH SELF-LOCKING NUT DIN 982 CL 8 M 22 Z. WHITE	ÉCROU	NUTTER	TUERCA
BD40	BD004000	NR	DADO BASSO AUTOBLOCCANTE PG DIN 985 CL 8 M 14 Z.BIANCA	LOW SELF-LOCKING NUT DIN 985 CL 8 M 14 Z. WHITE	ÉCROU	NUTTER	TUERCA
BD41	BD004100	NR	DADO ESAGONALE MEDIO PF DIN 934 CL 10 M 16 X 1,5 Z.BIANCA	MEDIUM HEXAGONAL NUT PF DIN 934 CL 10 M 16 X 1.5 Z.BIANCA	ÉCROU HEXAGONAL	NUTTER	TUERCA
BD42	BD004200	NR	DADO ALTO PG DIN 982 CL 8 M 24 Z.BIANCA	HIGH NUT DIN 982 PG CL 8 M24 Z. WHITE	ÉCROU PG DIN 982 CL 8 M 24 GALVANISÉ BLANC	NUTTER	TUERCA
BD45	BD004500	NR	DADO ESAGONALE BASSO MB DIN439 INOX A2 M10 X 1	LOW NUT DIN439 INOX MB M10 X 1	ÉCROU BAS DIN439 INOX MB M10 X 1	NUTTER	TUERCA
BD46	BD004600	NR	DADO ALTO AUTOBLOCCANTE PG DIN 982 INOX A2 M4	NUT PG DIN 982 INOX A2 M4	ÉCROU PG DIN 982 INOX A2 M4	NUTTER	TUERCA
BG1	BG000100	NR	GHIERA AUTOBLOCCANTE GN CL 6 GN 3 D. 17 X 1 Z.BIANCA	SELF-LOCKING NUT GN GN 3 CL 6 D. 17 X 1 Z. WHITE			
BG2	BG000200	NR	GHIERA AUTOBLOCCANTE PESANTE CL 6 GUP 40 X 1,5 Z.BIANCA	SELF-LOCKING NUT HEAVY CL 6 GUP 40 X 1.5 Z WHITE			







Viteria







Fasteners



POS	Codice	U.M.	Descrizione	Description	Designation	Benennung	Descripción
BG3	BG000300	NR	GHIERA AUTOBLOCCANTE PESANTE CL 6 GUP 35 X 1,5 Z.BIANCA	SELF-LOCKING NUT HEAVY CL 6 GUP 35 X 1.5 Z WHITE			
BG4	BG000400	NR	GHIERA AUTOBLOCCANTE PESANTE CL 6 GUP 25 X 1,5 Z.BIANCA	SELF-LOCKING NUT HEAVY CL 6 GUP 25 X 1.5 Z WHITE	ÉCROU AUTO-BLOQUANT	SELBSTSICHERNDE NUTMUTTER	
BG5	BG000500	NR	GHIERA AUTOBLOCCANTE PESANTE CL 6 GUP 30 X 1,5 Z.BIANCA	SELF-LOCKING NUT HEAVY CL 6 GUP 30 X 1.5 Z WHITE	BAGUE AUTOBLOQUANT LOURDE CL 6 GUP 30 X 1,5 Z.BLANCHE	SELBSTSICHERUNGSNUTMUTTER CL 6 GUP 30 X 1.5 Z WEIß	CASQUILLO AUTOBLOCANTE CL 6 GUP 30 X 1,5 GALVANIZADO BLANCO
BG6	BG000600	NR	GHIERA AUTOBLOCCANTE PESANTE CL 6 GUP 20 X 1 Z.BIANCA	SELF-LOCKING NUT HEAVY CL 6 GUP 20 X 1 Z. WHITE	BAGUE AUTOBLOQUANTE CL 6 GUP 20 X 1 Z.BLANCHE	SELBSTSICHERUNGSNUTMUTTER CL 6 GUP 20 X 1 Z. WEIß	CASQUILLO AUTOBLOCANTE CL 6 GUP 20 X 1 GALVANIZADO BLANCO
BG7	BG000700	NR	GHIERA AUTOBLOCCANTE GN CL 6 GN 3 D. 45 X 1,5 Z.BIANCA	NUT	BAGUE	NUTMUTTER	TUERCA
BG8	BG000800	NR	GHIERA AUTOBLOCCANTE GN CL 6 GN 3 D. 50 X 1,5 Z.BIANCA	NUT	BAGUE	NUTMUTTER	TUERCA
BG9	BG000900	NR	GHIERA AUTOBLOCCANTE GN CL 6 GN 3 D. 20 X 1,5 Z.BIANCA	NUT	BAGUE	NUTMUTTER	TUERCA
BG10	BG001000	NR	GHIERA AUTOBLOCCANTE RIBASSATA CL 6 GUK 25 X 1,5 Z.BIANCA	SELF-LOCKING NUT LOWERED CL 6 GUK 25 X 1.5 Z.BIANCA	BAGUE	NUTMUTTER	TUERCA
BG11	BG001100	NR	GHIERA AUTOBLOCCANTE RIBASSATA CL 6 GUK 20 X 1 Z.BIANCA	SELF-LOCKING NUT LOWERED CL 6 GUK 20 X 1 Z.BIANCA	BAGUE	NUTMUTTER	TUERCA
BG12	BG001200	NR	GHIERA AUTOBLOCCANTE RIBASSATA CL 6 GUA 20 X 1.5 Z.BIANCA	SELF-LOCKING NUT LOWERED CL 6 GUA 20 X 1.5 Z.BIANCA	BAGUE	NUTMUTTER	TUERCA
BG13	BG001300	NR	GHIERA AUTOBLOCCANTE RIBASSATA CL 6 GUK 30 X 1.5 Z.BIANCA	SELF-LOCKING NUT LOWERED CL 6 GUK 30 X 1.5 Z.BIANCA	BAGUE	NUTMUTTER	TUERCA
BG14	BG001400	NR	GHIERA AUTOBLOCCANTE RIBASSATA CL 6 GUK 45 X 1.5 Z.BIANCA	SELF-LOCKING NUT LOWERED CL 6 GUK 45 X 1.5 Z.BIANCA	BAGUE	NUTMUTTER	TUERCA

POS	Codice	U.M.	 Descrizione	 Description	 Designation	 Benennung	 Descripción
BG15	BG001500	NR	GHIERA AUTOBLOCCANTE RIBASSATA CL 6 GUK 50 X 1.5 Z.BIANCA	SELF-LOCKING NUT LOWERED CL 6 GUK 50 X 1.5 Z.BIANCA	BAGUE	NUTMUTTER	TUERCA
BG16	BG001600	NR	GHIERA AUTOBLOCCANTE RIBASSATA CL 6 GUK 55 X 2 Z.BIANCA	SELF-LOCKING NUT LOWERED CL 6 GUK 55 X 2 Z.BIANCA	BAGUE	NUTMUTTER	TUERCA
BG17	BG001700	NR	GHIERA AUTOBLOCCANTE GN CL 6 GN 1 D. 12 X 1 Z.BIANCA	SELF-LOCKING NUT GN CL 6 GN 1 D. 12 X 1 Z. WHITE	BAGUE	NUTMUTTER	TUERCA
BG18	BG001800	NR	GHIERA AUTOBLOCCANTE GN CL 6 GN 3 D. 65 X 2 Z.BIANCA	NUT	BAGUE	NUTMUTTER	TUERCA
BI1	BI000100	NR	INSERTO ESAGONALE M6	INSERT HEX M6	INSERT FILETE M9 TETE REDUITE	GEWINDEINSERT M9 REDUZIERTER KOPF	INSERTO ROSCADO M9 CABEZA REDUCIDA
BI2	BI000200	NR	INSERTO ESAGONALE M5	INSERT HEX M5	INSERT FILETE M5 TETE REDUITE	GEWINDEINSERT M5 REDUZIERTER KOPF	INSERTO ROSCADO M5 CABEZA REDUCIDA
BI3	BI000300	NR	INSERTO CILINDRICO M4	INSERT M4			
BI4	BI000400	NR	INSERTO CILINDRICO M6	INSERT M6			
BI5	BI000500	NR	INSERTO ESAGONALE M8	INSERT HEX M8	INSERT FILETE M8 TETE REDUITE	GEWINDEINSERT M8 REDUZIERTER KOPF	INSERTO ROSCADO M8 CABEZA REDUCIDA
BI6	BI000600	NR	INSERTO ESAGONALE M4	INSERT HEX M4	INSERT FILETE M4 TETE REDUITE	GEWINDEINSERT M4 REDUZIERTER KOPF	INSERTO ROSCADO M4 CABEZA REDUCIDA
BI7	BI000700	NR	INSERTO CILINDRICO M8	INSERT M8			
BR1	BR000100	NR	GROWER SEZ.RETT.SPIGOLI VIVI PESANTE UNI 9195 ACC.MOLLE D 6 Z.D.BIANCA	GROWER SEZ.RETT. SHARP HEAVY UNI 9195 ACC.MOLLE D 6 Z.D. WHITE	RONDELLE GROWER SECT.RECT. UNI 9195 ACC.MOLLE D 6 GALVANISÉE BLANCHE	GROWER UNTERLEGSCHIEBE UNI 9195 D 6 Z.D. WEIß	ARANDELA GROWER SEC. RECT. UNI 9195 D 6 GALVANIZADA BLANCA
BR2	BR000200	NR	RONDELLA PIANA DIN 125-A HV100 D 4 Z.BIANCA	PLAIN WASHER DIN 125-A HV100 D 4 Z. WHITE	RONDELLE PLATE DIN 125-A HV100 D 4 Z.BLANCHE	FLACHE UNTERLEGSCHIEBE DIN 125-A HV100 D 4 Z.WEIß	ARANDELA PLANA DIN 125-A HV100 D 4 GALVANIZADA BLANCA
BR3	BR000300	NR	RONDELLA PIANA DIN 125-A HV100 D 5 Z.BIANCA	PLAIN WASHER DIN 125-A HV100 D 5 Z. WHITE	RONDELLE PLATE DIN 125-A HV100 D 5 Z.BLANCHE	FLACHE UNTERLEGSCHIEBE DIN 125-A HV100 D 5 Z.WEIß	ARANDELA PLANA DIN 125-A HV100 D 5 GALVANIZADA BLANCA

POS	Codice	U.M.	 Descrizione	 Description	 Designation	 Benennung	 Descripción
BR4	BR000400	NR	RONDELLA PIANA DIN 125-A HV100 D 6 Z.BIANCA	PLAIN WASHER DIN 125-A HV100 D 6 Z. WHITE	RONDELLE PLATE DIN 125-A HV100 D 6 Z.BLANCHE	FLACHE UNTERLEGSCHLEIBE DIN 125-A HV100 D 6 Z. WEIß	ARANDELA PLANA DIN 125-A HV100 D 6 GALVANIZADA BLANCA
BR5	BR000500	NR	RONDELLA PIANA DIN 125-A HV100 D 8 Z.BIANCA	PLAIN WASHER DIN 125-A HV100 D 8 Z. WHITE	RONDELLE PLATE DIN 125-A HV100 D 8 Z.BLANCHE	FLACHE UNTERLEGSCHLEIBE DIN 125-A HV100 D 8 Z. WEIß	ARANDELA PLANA DIN 125-A HV100 D 8 GALVANIZADA BLANCA
BR6	BR000600	NR	RONDELLA PIANA DIN 125-A HV100 D 10 Z.BIANCA	PLAIN WASHER DIN 125-A HV100 D 10 Z. WHITE	RONDELLE PLATE DIN 125-A HV100 D 10 Z.BLANCHE	FLACHE UNTERLEGSCHLEIBE DIN 125-A HV100 D 10 Z. WEIß	ARANDELA PLANA DIN 125-A HV100 D 10 GALVANIZADA BLANCA
BR7	BR000700	NR	RONDELLA PIANA DIN 125-A HV100 D 12 Z.BIANCA	PLAIN WASHER DIN 125-A HV100 D 12 Z. WHITE	RONDELLE PLATE DIN 125-A HV100 D 12 Z.BLANCHE	FLACHE UNTERLEGSCHLEIBE DIN 125-A HV100 D 12 Z. WEIß	ARANDELA PLANA DIN 125-A HV100 D 12 GALVANIZADA BLANCA
BR8	BR000800	NR	ROSETTA PIANA FASCIA LARGA E=3D DIN 9021 HV100 D 10 X 30 X 2,5 Z.BIANCA	WIDE BAND AND FLAT WASHER DIN 9021 HV100 3D = D 10 X 30 X 2.5 Z WHITE	RONDELLE PLATE BANDE LARGE E=3D DIN 9021 HV100 D 10 X 30 X 2,5 Z.BLANCHE	FLACHE UNTERLEGSCHLEIBE DIN 9021 HV100 3D = D 10 X 30 X 2.5 Z WEIß	ARANDELA DE BANDA ANCHA DIN 9021 HV100 D 10 X 30 X 2,5 GALVANIZADA BLANCA
BR9	BR000900	NR	ROSETTA PIANA FASCIA LARGA E=3D DIN 9021 HV100 D 12 X 36 X 2,5 Z.BIANCA	WIDE BAND AND FLAT WASHER DIN 9021 HV100 3D = D 12 X 36 X 2.5 Z WHITE	RONDELLE PLATE LARGE BANDE =3D DIN 9021 HV100 D 12 X 36 X 2,5 GALVANISÉE BLANCHE	SCHEIBE	ARANDELA
BR10	BR001000	NR	RONDELLA X CARPENTERIA DIN 6916 HV 300 D 16 Z.BIANCA	CARPENTRY WASHER DIN 6916 HV 300 D 16 Z WHITE	RONDELLE POUR CHARPENTERIE DIN 6916 HV 300 D 16 Z.BLANCHE	ZIMMEREI UNTERLEGSCHLEIBE DIN 6916 HV 300 D 16 Z WEIß	ARANDELA DE CARPINTERÍA DIN 6916 HV 300 D 16 GALVANIZADA BLANCA
BR11	BR001100	NR	ROSETTE SPECIALI HV100 D 25 X 51 X 1 Z.BIANCA	SPECIAL WASHERS HV100 D 25 X 51 X 1 Z. WHITE	RONDELLES SPÉCIALES HV100 D 25 X 51 X 1 GALVANISATION BLANCHE	SCHEIBE	ARANDELA
BR13	BR001300	NR	RONDELLA DENTELLATURA ESTERNA DIN 6798-A ACC.MOLLE D 3 Z.D.BIANCA	WASHER EXTERNAL SERRATION DIN 6798-A ACC.MOLLE D 3 ZD WHITE	RONDELLE À DENTURE EXTÉRIEURE DIN 6798-A ACC.MOLLE D 3 Z.D GALVANISATION BLANCHE	SCHEIBE	ARANDELA
BR14	BR001400	NR	ROSETTA PIANA FASCIA LARGA E=3D DIN 9021 HV100 D 5 X 15 X 1,2 Z.BIANCA	WIDE BAND AND FLAT WASHER DIN 9021 HV100 3D = D 5 X 15 X 1.2 Z WHIT	RONDELLE PLATE BANDE LARGE E=3D DIN 9021 HV100 D 5 X 15 X 1,2 Z.BLANCHE	UNTERLEGSCHLEIBE DIN 9021 HV100 3D = D 5 X 15 X 1.2 Z WEIß	ARANDELA PLANA CINTA LUNGA DIN 9021 HV100 D 5 X 15 X 1,2 GALVANIZADA BLANCA

POS	Codice	U.M.	 Descrizione	 Description	 Designation	 Benennung	 Descripción
BR15	BR001500	NR	ROSETTA PIANA FASCIA LARGA E=3D DIN 9021 HV100 D 6 X 18 X 1,5 Z.BIANCA	WIDE BAND AND FLAT WASHER DIN 9021 HV100 3D = D 6 X 18 X 1.5 Z WHITE	RONDELLE PLATE BANDE LARGE E=3D DIN 9021 HV100 D 6 X 18 X 1,5 Z.BLANCHE	UNTERLEGSSCHEIBE DIN 9021 HV100 3D = D 6 X 18 X 1.5 Z WEIß	ARANDELA PLANA CINTA LUNGA E=3D DIN 9021 HV100 D 6 X 18 X 1,5 GALVANIZADA BLANCA
BR16	BR001600	NR	ROSETTA PIANA FASCIA LARGA E=3D DIN 9021 HV100 D 8 X 24 X 2 Z.BIANCA	WIDE BAND AND FLAT WASHER DIN 9021 HV100 3D = D 8 X 24 X 2 Z. WHITE	RONDELLE PLATE BANDE LARGE E=3D DIN 9021 HV100 D 8 X 24 X 2 Z.BLANCHE	UNTERLEGSSCHEIBE DIN 9021 HV100 3D = D 8 X 24 X 2 Z. WEIß	ARANDELA PLANA CINTA LUNGA E=3D DIN 9021 HV100 D 8 X 24 X 2 GALVANIZADA BLANCA
BR17	BR001700	NR	ROSETTA PIANA FASCIA LARGA E=3D DIN 9021 HV100 D 4 X 12 X 1 Z.BIANCA	WIDE BAND AND FLAT WASHER DIN 9021 HV100 D = 3D 4 X 12 X 1 Z. WHITE	RONDELLE PLASTE BANDE LARGEDIN 9021 HV100 D 4 X 12 X 1 GALVANISATION BLANCHE	SCHEIBE	ARANDELA
BR18	BR001800	NR	RONDELLA PIANA DIN 125-A NYLON D 4	PLAIN WASHER DIN 125-A NYLON D 4	RONDELLE PLATE DIN 125-A NYLON D 4	SCHEIBE	ARANDELA
BR19	BR001900	NR	RONDELLA PIANA DIN 125-A HV100 D 3 Z.BIANCA	PLAIN WASHER DIN 125-A HV100 D 3 Z. WHITE	RONDELLE PLATE DIN 125-A HV100 D 3 GALVANISATION BLANCHE	SCHEIBE	ARANDELA
BR20	BR002000	NR	RONDELLA PIANA DIN 125-A HV100 D 16 Z.BIANCA	PLAIN WASHER DIN 125-A HV100 D 16 Z. WHITE	RONDELLE PLATE DIN 125-A HV100 D 16 GALVANISATION BLANCHE	SCHEIBE	ARANDELA
BR21	BR002100	NR	ROSETTA PIANA FASCIA LARGA E=3D DIN 9021 HV100 D 16 X 48 X 4 Z.BIANCA	WIDE BAND AND FLAT WASHER DIN 9021 HV100 3D = D 16 X 48 X 4 Z. WHITE	RONDELLE PLATE BANDE LARGE E=3D DIN 9021 HV100 D 16 X 48 X 4 GALVANISÉE BLANCHE	FLACHE UNTERLEGSSCHEIBE DIN 9021 HV100 3D = D 16 X 48 X 4 Z. WEIß	ARANDELA PLANA BANDA ANCHA DIN 9021 HV100 D 16 X 48 X 4 GALVANIZADA BLANCA
BR22	BR002200	NR	GROWER SEZ.RETT.SPIGOLI VIVI PESANTE UNI 9195 ACC.MOLLE D 8 Z.D.BIANCA	GROWER SECTION. RECT. SHARP HEAVY UNI 9195 STAINLESS SPRINGS D 8 Z.D. WHITE	RONDELLE GROWER SECT. RECT. ARÊTES AIGUËS D 8 Z.D. BLANC	GROWER UNTERLEGSSCHEIBE - WEIß	ARANDELA GROWER SECT. RECT. ÁNGULOS VIVOS UNI 9195 GALVANIZADA BLANCA
BR23	BR002300	NR	ROSETTA PIANA FASCIA LARGA E=3D DIN 9021 HV100 D 3 X 12 X 1 Z.BIANCA	WIDE BAND AND FLAT WASHER DIN 9021 HV100 D = 3D 3 X 12 X 1 Z. WHITE	RONDELLE PLATE BANDE LARGE DIN 9021 HV100 D 3 X 12 X 1 GALVANISATION BLANCHE	SCHEIBE	ARANDELA
BR24	BR002400	NR	ROSETTA PIANA FASCIA LARGA E=3D DIN 9021 HV100 D 14 X 42 X 3 Z.BIANCA	WIDE BAND AND FLAT WASHER DIN 9021 HV100 D = 3D 14 X 42 X 3 Z. WHITE	RONDELLE PLATE BANDE LARGE DIN 9021 HV100 D 14 X 42 X 3 GALVANISATION BLANCHE	SCHEIBE	ARANDELA

POS	Codice	U.M.	 Descrizione	 Description	 Designation	 Benennung	 Descripción
BR25	BR002500	NR	GROWER SEZ.RETT.SPIGOLI VIVI PESANTE UNI 9195 ACC.MOLLE D 10 Z.D.BIANCA	GROWER SEZ.RETT. SHARP HEAVY UNI 9195 ACC.MOLLE D 10 Z.D. WHITE	RONDELLE GROWER SECT. RECT. ARÊTES AIGUËS UNI 9195 D 10 Z.D. BLANC	GROWER UNTERLEGSCHIEBE - WEIß	ARANDELA GROWER SECT. RECT. ÁNGULOS VIVOS UNI 9195 GALVANIZADA BLANCA
BR26	BR002600	NR	RONDELLA PIANA DIN 125-A D 30 Z.BIANCA	PLAIN WASHER DIN 125-A D 30 Z. WHITE	RONDELLE PLATE DIN 125-A D 30 GALVANISATION BLANCHE	SCHEIBE	ARANDELA
BR27	BR002700	NR	RONDELLA PIANA DIN 125-A HV100 D 14 Z.BIANCA	PLAIN WASHER DIN 125-A HV100 D 14 Z. WHITE	RONDELLE PLATE DIN 125-A HV100 D 14 Z.BLANCHE	FLACHE UNTERLEGSCHIEBE DIN 125-A HV100 D 14 Z. - WEIß	ARANDELA PLANA DIN 125-A HV100 D 14 GALVANIZADA BLANCA
BR28	BR002800	NR	ROSETTA PIANA FASCIA LARGA D 6 X 24 X 2 Z.BIANCA	WIDE BAND AND FLAT WASHER D 6 X 24 X 2 Z WHITE	RONDELLE PLATE BANDE LARGE D 6 X 24 X 2 Z BLANCHE	UNTERLEGSCHIEBE D 6 X 24 X 2 Z - WEIß	ARANDELA PLANA CINTA LUNGA D 6 X 24 X 2 GALVANIZADA BLANCA
BR29	BR002900	NR	RONDELLA PIANA DIN 125-A HV100 D 18 Z.BIANCA	PLAIN WASHER DIN 125-A HV100 D 18 Z. WHITE	RONDELLE PLATE DIN 125-A HV100 D 18 Z. BLANC	FLACHE UNTERLEGSCHIEBE DIN 125-A HV100 D 18 Z. WEIß	ARANDELA PLANA DIN 125-A HV100 D 18 GALVANIZADA BLANCA
BR30	BR003000	NR	RONDELLA PIANA DIN 125-A HV100 D 20 Z.BIANCA	PLAIN WASHER DIN 125-A HV100 D 20 Z. WHITE	RONDELLE PLATE DIN 125-A HV100 D 20 GALVANISÉE BLANCHE	FLACHE UNTERLEGSCHIEBE DIN 125-A HV100 D 20 Z. WEIß	ARANDELA PLANA DIN 125-A HV100 D 20 GALVANIZADA BLANCA
BR31	BR003100	NR	GROWER SEZ.RETT.SPIGOLI VIVI PESANTE UNI 9195 ACC.MOLLE D 12 Z.D.BIANCA	GROWER SEZ.RETT. SHARP HEAVY UNI 9195 ACC.MOLLE D 12 Z.D. WHITE	RONDELLE GROWER SECT. RECT. ARÊTE AIGUË UNI 9195 ACC.MOLLE D 12 Z.D.BLANC	GROWER UNTERLEGSCHIEBE UNI 9195 ACC.MOLLE D 12 Z.D. WEIß	ARANDELA GROWER SECT. RECT. ÁNGULOS VIVOS UNI 9195 D 12 GALVANIZADA BLANCA
BR32	BR003200	NR	ROSETTE SPECIALI HV100 D 30 X 42 X 0.5 Z.BIANCA	SPECIAL WASHERS HV100 D 30 X 42 X 0.5 Z. WHITE	RONDELLES SPÉCIALES HV100 D 30 X 42 X 0.5 GALVANISATION BLANCHE	SCHEIBE	ARANDELA
BR33	BR003300	NR	ROSETTE SPECIALI HV100 D 30 X 61 X 1 Z.BIANCA	SPECIAL WASHERS HV100 D 30 X 61 X 1 Z. WHITE	RONDELLES SPÉCIALES HV100 D 30 X 61 X 1 GALVANISATION BLANCHE	SCHEIBE	ARANDELA
BR34	BR003400	NR	ROSETTE SPECIALI HV100 D 42 X 52 X 0.2 Z.BIANCA	SPECIAL WASHERS HV100 D 42 X 52 X 0.2 Z. WHITE	RONDELLES SPÉCIALES HV100 D 42 X 52 X 0.2 GALVANISATION BLANCHE	SCHEIBE	ARANDELA
BR35	BR003500	NR	ROSETTE SPECIALI HV100 D 42 X 52 X 0.3 Z.BIANCA	SPECIAL WASHERS HV100 D 42 X 52 X 0.3 Z. WHITE	RONDELLES SPÉCIALES HV100 D 42 X 52 X 0.3 GALVANISATION BLANCHE	SCHEIBE	ARANDELA







Viteria











Fasteners







POS	Codice	U.M.	Descrizione	Description	Designation	Benennung	Descripción
BR36	BR003600	NR	ROSETTE SPECIALI HV100 D 42 X 52 X 1 Z.BIANCA	SPECIAL WASHERS HV100 D 42 X 52 X 1 Z. WHITE	RONDELLES SPÉCIALES HV100 D 42 X 52 X 1 GALVANISATION BLANCHE	SCHEIBE	ARANDELA
BR37	BR003700	NR	ROSETTE SPECIALI HV100 D 42 X 52 X 1.5 Z.BIANCA	SPECIAL WASHERS HV100 D 42 X 52 X 1.5 Z. WHITE	RONDELLES SPÉCIALES HV100 D 42 X 52 X 1.5 GALVANISATION BLANCHE	SCHEIBE	ARANDELA
BR38	BR003800	NR	ROSETTE SPECIALI HV100 D 42 X 52 X 2 Z.BIANCA	SPECIAL WASHERS HV100 D 42 X 52 X 2 Z. WHITE	RONDELLES SPÉCIALES HV100 D 42 X 52 X 2 GALVANISATION BLANCHE	SCHEIBE	ARANDELA
BR39	BR003900	NR	ROSETTA PIANA FASCIA LARGA E=3D DIN 9021 HV100 D 18 X 48 X 4 Z.BIANCA	WIDE BAND AND FLAT WASHER DIN 9021 HV100 3D = D 18 X 48 X 4 Z. WHITE	RONDELLE PLATE BANDE LARGE E=3D DIN 9021 HV100 D 18 X 48 X 4 GALVANISÉE BLANCHE	FLACHE UNTERLEGSCHIEBE DIN 9021 HV100 3D = D 18 X 48 X 4 Z. WEIß	ARANDELA PLANA BANDA ANCHA DIN 9021 HV100 D 18 X 48 X 4 GALVANIZADA BLANCA
BR40	BR004000	NR	ROSETTA SCHNORR ZINCATE D 6	WASHER	RONDELLE	SCHEIBE	ARANDELA
BR41	BR004100	NR	GROWER SEZ.RETT.SPIGOLI VIVI PESANTE UNI 9195 ACC.MOLLE D 14 Z.D.BIANCA	GROWER SEZ.RETT. SHARP HEAVY UNI 9195 ACC.MOLLE D 14 Z.D. WHITE	RONDELLE GROWER SECT. RECT. ARÊTE AIGUË UNI 9195 ACC.MOLLE D 14 Z.D.BLANC	GROWER UNTERLEGSCHIEBE UNI 9195 ACC.MOLLE D 14 Z.D. WEIß	ARANDELA GROWER SECT. RECT. ÁNGULOS VIVOS UNI 9195 D 14 GALVANIZADA BLANCA
BR42	BR004200	NR	RONDELLA X CARPENTERIA DIN 6916 HV 300 D 14 Z.BIANCA	CARPENTRY WASHER DIN 6916 HV 300 D 14 Z WHITE	RONDELLE POUR CHARPENTERIE DIN 6916 HV 300 D 14 Z.BLANCHE	ZIMMEREI UNTERLEGSCHIEBE DIN 6916 HV 300 D 14 Z WEIß	ARANDELA DE CARPINTERÍA DIN 6916 HV 300 D 14 GALVANIZADA BLANCA
BR43	BR004300	NR	RONDELLA X CARPENTERIA DIN 125-A HV 300 D 10 Z.BIANCA	CARPENTRY WASHER DIN 125-A HV 300 D 10 Z WHITE	RONDELLE POUR CHARPENTERIE DIN 125-A HV 300 D 10 Z.BLANCHE	ZIMMEREI UNTERLEGSCHIEBE DIN 125-A HV 300 D 10 Z WEIß	ARANDELA DE CARPINTERÍA DIN 125-A HV 300 D 10 GALVANIZADA BLANCA
BR44	BR004400	NR	RONDELLA X CARPENTERIA DIN 125-A HV 300 D 20 Z.BIANCA	CARPENTRY WASHER DIN 125-A HV 300 D 20 Z WHITE	RONDELLE POUR CHARPENTERIE DIN 125-A HV 300 D 20 Z.BLANCHE	ZIMMEREI UNTERLEGSCHIEBE DIN 125-A HV 300 D 20 Z WEIß	ARANDELA DE CARPINTERÍA DIN 125-A HV 300 D 20 GALVANIZADA BLANCA
BR45	BR004500	NR	RONDELLA PIANA DIN 125-A HV200 D 10 Z.BIANCA	PLAIN WASHER DIN 125-A HV200 D 10 Z. WHITE	RONDELLE POUR CHARPENTERIE	ZIMMEREI UNTERLEGSCHIEBE	ARANDELA DE CARPINTERÍA
BR48	BR004800	NR	RONDELLA PIANA DIN 125-A HV100 D 22 Z.BIANCA	PLAIN WASHER DIN 125-A HV100 D 22 Z. WHITE	RONDELLE POUR CHARPENTERIE	ZIMMEREI UNTERLEGSCHIEBE	ARANDELA DE CARPINTERÍA





POS	Codice	U.M.	 Descrizione	 Description	 Designation	 Benennung	 Descripción
BR49	BR004900	NR	ROSETTA PIANA FASCIA LARGA E=4D DIN 9021 HV100 D 12 X 48 X 2,5 Z.BIANCA	WASHER FLAT AND WIDE BAND E = 4D DIN 9021 HV100 D 12 X 48 X 2.5 Z. WHITE	RONDELLE POUR CHARPENTERIE	ZIMMEREI UNTERLEGSCHIEBE	ARANDELA DE CARPINTERÍA
BR50	BR005000	NR	ROSETTA PIANA FASCIA LARGA E=3D DIN 9021 HV100 D 20 X 60 X 4 Z.BIANCA	WASHER FLAT AND WIDE BAND E = 3D DIN 9021 HV100 D 20 X 60 X 4 Z. WHITE	RONDELLE POUR CHARPENTERIE	ZIMMEREI UNTERLEGSCHIEBE	ARANDELA DE CARPINTERÍA
BR53	BR005300	NR	RONDELLE ELASTICHE GROWER DIN 127-B ACC.MOLLE D 6 Z.D.BIANCA	ELASTIC WASHERS GROWER DIN 127-B ACC. SPRINGS D 6 Z.D. WHITE	RONDELLE POUR CHARPENTERIE	ZIMMEREI UNTERLEGSCHIEBE	ARANDELA DE CARPINTERÍA
BR54	BR005400	NR	ROSETTA DI SICUREZZA TIPO SCHNORR TIPO S INOX D 6	WASHER SCHNORR TYPE S INOX D 6 SECURITY	RONDELLE POUR CHARPENTERIE	ZIMMEREI UNTERLEGSCHIEBE	ARANDELA DE CARPINTERÍA
BR55	BR005500	NR	RONDELLA DENTELLATURA ESTERNA DIN 6798-A ACC.MOLLE D 5 Z.D.BIANCA	WASHER EXTERNAL SERRATION DIN 6798-A ACC. SPRINGS D 5 Z.D. WHITE	RONDELLE POUR CHARPENTERIE	ZIMMEREI UNTERLEGSCHIEBE	ARANDELA DE CARPINTERÍA
BR56	BR005600	NR	RONDELLA X CARPENTERIA DIN 6916 HV 300 D 12 Z.BIANCA	WASHER DIN 6916 HV 300 D 12 Z. WHITE	RONDELLE POUR CHARPENTERIE	ZIMMEREI UNTERLEGSCHIEBE	ARANDELA DE CARPINTERÍA
BR57	BR005700	NR	ROSETTE SPECIALI HV100 D 36 X 65 X 1 Z.BIANCA	SPECIAL WASHERS HV100 D 36 X 65 X 1 Z. WHITE	RONDELLES SPÉCIALES HV100 D 36 X 65 X 1 GALVANISATION BLANCHE	SCHEIBE	ARANDELA
BR58	BR005800	NR	ROSETTE SPECIALI HV100 D 50 X 60 X 1 Z.BIANCA	SPECIAL WASHERS HV100 D 50 X 60 X 1 Z. WHITE	RONDELLES SPÉCIALES HV100 D 50 X 60 X 1 GALVANISATION BLANCHE	SCHEIBE	ARANDELA
BR59	BR005900	NR	ROSETTE SPECIALI HV300 D 20 X 54 X 3 Z.BIANCA	SPECIAL WASHERS HV300 D 20 X 54 X 3 Z. WHITE	RONDELLES SPÉCIALES HV300 D 20 X 54 X 3 GALVANISATION BLANCHE	SCHEIBE HV300 D 20 X 54 X 3	ARANDELA HV300 D 20 X 54 X 3 Z.
BR60	BR006000	NR	RONDELLA PIANA DIN 125-A NYLON D 12	PLAIN WASHER DIN 125-A NYLON D 12	RONDELLE PLATE DIN 125-A NYLON D 12	SCHEIBE	ARANDELA
BR61	BR006100	NR	RONDELLA PIANA DIN 125-A INOX A2 D4	PLAIN WASHER DIN 125-A INOX A2 D4	RONDELLE POUR CHARPENTERIE	ZIMMEREI UNTERLEGSCHIEBE	ARANDELA DE CARPINTERÍA
BR62	BR006200	NR	RONDELLA PIANA DIN 125-A HV300 D 20 Z.BIANCA	PLAIN WASHER DIN 125-A HV300 D 20 Z. WHITE	RONDELLE POUR CHARPENTERIE	ZIMMEREI UNTERLEGSCHIEBE	ARANDELA DE CARPINTERÍA
BR63	BR006300	NR	RONDELLA ANTIROTAZIONE DIN463 HV100 D6.4 X M6	WASHER DIN463 HV100 D6.4 X M6	RONDELLE POUR CHARPENTERIE	ZIMMEREI UNTERLEGSCHIEBE	ARANDELA DE CARPINTERÍA

POS	Codice	U.M.	 Descrizione	 Description	 Designation	 Benennung	 Descripción
BS1	BS000100	NR	GRANO FILETTATO M6X12	SCREW	VIS	SCHRAUBE	TORNILLO
BS2	BS000200	NR	SPINA CIL. 8X16 UNI 6364-A H6 CMT + TMP	PIN CYLINDER 8 X 16 UNI 6364-A CMT H6 + TMP			
BS3	BS000300	NR	PRIGIONIERO M10X35	PIN	AXE	GEWINDESTIFT	CLAVIJA
BS4	BS000400	NR	SPINA ELASTICA 6X60 UNI 6873	PIN	AXE	STIFT	CLAVIJA
BS5	BS000500	NR	SPINA ELASTICA 6X14 UNI 6873	PIN	AXE	STIFT	CLAVIJA
BS6	BS000600	NR	SPINA SPIROL NORMALE DIN 7343 INOX A2 D 5X10	PIN	AXE	STIFT	CLAVIJA
BS7	BS000700	NR	RIVETTO ALLUMINIO Ø3X12	ALUMINUM RIVET Ø3X12			
BS8	BS000800	NR	MOLLA COMPRESSIONE INOX AISI 302 D10.668 S1.066 L31.75	SPRING COMPRESSION AISI 302 D10.668 S1.066 L31.75			
BS13	BS001300	NR	SPINA ELASTICA DIN 1481 ACC.MOLLE D 8 X 50	ELASTIC PIN DIN 1481 ACC SPRINGS D 8 X 50			
BS14	BS001400	NR	SPINA SPIROL NORMALE DIN 7343 ACC.MOLLE D 5 X 10	PIN SPIROL NORMAL DIN 7343 ACC. SPRINGS D 5 X 10			
BS15	BS001500	NR	RIVETTI A STRAPPO TB AL/AC DIN 7337 D 3,2 X 12	BLIND RIVETS TB AL / AC DIN 7337 D 3.2 X 12			
BS16	BS001600	NR	RIVETTI A STRAPPO TB AL/AC DIN 7337 D 4,8 X 12	BLIND RIVETS TB AL / AC DIN 7337 D 4.8 X 12			
BS17	BS001700	NR	RIVETTI A STRAPPO TB A2/A2 DIN 7337 D 4,8 X 12	BLIND RIVETS TB A2 / A2 DIN 7337 D 4.8 X 12			
BS21	BS002100	NR	RIVETTO ALLUMINIO Ø4X10	ALUMINUM RIVET Ø4X10			
BS22	BS002200	NR	PRIGIONIERO M10X80	PIN M10X80	AXE M10X80	GEWINDESTIFT M10X80	CLAVIJA M10X80
BV1	BV000100	NR	VITE TE PARZIALE FILETTO PG DIN 931 CL 8.8 M 8 X 80 Z.BIANCA	SCREW PARTIAL THREAD DIN 931 PG CL 8.8 M 8 X 80 Z. WHITE	VIS PARTIELLEMENT FILETÉE DIN 931 CL 8.8 M 8 X 80 GALVANISATION BLANCHE	SCHRAUBE	TORNILLO
BV2	BV000200	NR	VITE TE TUTTO FILETTO PG DIN 933 CL 8.8 M 8 X 60 Z.BIANCA	SCREW ALL THREAD DIN 933 PG CL 8.8 M 8 X 60 Z. WHITE	VIS ENTIÈREMENT FILETÉE DIN 933 CL 8.8 M 8 X 60 GALVANISATION BLANCHE	SCHRAUBE	TORNILLO

POS	Codice	U.M.	 Descrizione	 Description	 Designation	 Benennung	 Descripción
BV3	BV000300	NR	VITE TCEI PG DIN 912 CL 8.8 M 8 X 60 Z.BIANCA	SCREW DIN 912 PG CL 8.8 M8 X 60 Z. WHITE	VIS DIN 912 CL 8.8 M 8 X 60 GALVANISATION BLANCHE	SCHRAUBE	TORNILLO
BV4	BV000400	NR	VITE TE PARZIALE FILETTO PG DIN 931 CL 8.8 M 8 X 50 Z.BIANCA	SCREW PARTIAL THREAD DIN 931 PG CL 8.8 M 8 X 50 Z. WHITE	VIS PARTIELLEMENT FILETÉE BLANC	TEILGEWINDESCHRAUBE DIN 931 PG CL 8.8 M 8 X 50 Z. WEIß	TORNILLO PARCIALMENTE ROSCADO PG DIN 931 CL 8.8 M 8 X 50 GALVANIZADO BLANCO
BV5	BV000500	NR	VITE TCEI PG DIN 912 CL 8.8 M 8 X 45 Z.BIANCA	SCREW DIN 912 PG CL 8.8 M8 X 45 Z. WHITE	VIS DIN 912 CL 8.8 M 8 X 45 GALVANISATION BLANCHE	SCHRAUBE	TORNILLOL
BV6	BV000600	NR	VITE TCEI PG DIN 912 CL 8.8 M 8 X 40 Z.BIANCA	SCREW DIN 912 PG CL 8.8 M8 X 40 Z.BIANCA	VIS DIN 912 CL 8.8 M 8 X 40 GALVANISATION BLANCHE	SCHRAUBE	TORNILLO
BV7	BV000700	NR	VITE TE TUTTO FILETTO PG DIN 933 CL 8.8 M 8 X 35 Z.BIANCA	SCREW ALL THREAD DIN 933 PG CL 8.8 M 8 X 35 Z. WHITE	VIS TE ENTIÈREMENT FILETÉE DIN 933 PG CL 8.8 M 8 X 35 Z. BLANC	VOLLGEWINDESCHRAUBE DIN 933 PG CL 8.8 M 8 X 35 Z. WEIß	TORNILLO TOTALMENTE ROSCADO PG DIN 933 CL 8.8 M 8 X 35 GALVANIZADO BLANCO
BV8	BV000800	NR	VITE TE TUTTO FILETTO PG DIN 933 CL 8.8 M 8 X 30 Z.BIANCA	SCREW ALL THREAD DIN 933 PG CL 8.8 M 8 X 30 Z. WHITE	VIS TE ENTIÈREMENT FILETÉE DIN 933 PG CL 8.8 M 8 X 30 Z. BLANC	VOLLGEWINDESCHRAUBE DIN 933 PG CL 8.8 M 8 X 30 Z. WEIß	TORNILLO TOTALMENTE ROSCADO PG DIN 933 CL 8.8 M 8 X 30 GALVANIZADO BLANCO
BV9	BV000900	NR	VITE TE TUTTO FILETTO PG DIN 933 CL 8.8 M 8 X 25 Z.BIANCA	SCREW ALL THREAD DIN 933 PG CL 8.8 M 8 X 25 Z. WHITE	VIS TE ENTIÈREMENT FILETÉE PG DIN 933 CL 8.8 M 8 X 25 Z.BLANC	VOLLGEWINDESCHRAUBE DIN 933 PG CL 8.8 M 8 X 25 Z. WEIß	TORNILLO TOTALMENTE ROSCADO PG DIN 933 CL 8.8 M 8 X 25 GALVANIZADO BLANCO
BV10	BV001000	NR	VITE TCEI PG DIN 912 CL 8.8 M 8 X 25 Z.BIANCA	SCREW DIN 912 PG CL 8.8 M8 X 25 Z. WHITE	VIS TCEI PG DIN 912 CL 8.8 M 8 X 25 Z.BLANC	SCHRAUBE DIN 912 PG CL 8.8 M8 X 25 Z. WEIß	TORNILLO TCEI PG DIN 912 CL 8.8 M 8 X 25 GALVANIZADO BLANCO
BV11	BV001100	NR	VITE TE TUTTO FILETTO PG DIN 933 CL 8.8 M 8 X 20 Z.BIANCA	SCREW ALL THREAD DIN 933 PG CL 8.8 M 8 X 20 Z. WHITE	VIS TE ENTIÈREMENT FILETÉE PG DIN 933 CL 8.8 M 8 X 20 Z.BLANC	VOLLGEWINDESCHRAUBE DIN 933 PG CL 8.8 M 8 X 20 Z. WEIß	TORNILLO TOTALMENTE ROSCADO PG DIN 933 CL 8.8 M 8 X 20 GALVANIZADO BLANCO
BV12	BV001200	NR	VITE TE TUTTO FILETTO PG DIN 933 CL 8.8 M 8 X 16 Z.BIANCA	SCREW ALL THREAD DIN 933 PG CL 8.8 M 8 X 16 Z. WHITE	VIS TE ENTIÈREMENT FILETÉE PG DIN 933 CL 8.8 M 8 X 16 Z.BLANC	VOLLGEWINDESCHREUBE DIN 933 PG CL 8.8 M 8 X 16 Z. WEIß	TORNILLO TOTALMENTE ROSCADO PG DIN 933 CL 8.8 M 8 X 16 GALVANIZADO BLANCO
BV13	BV001300	NR	VITE TCEI PG DIN 912 CL 8.8 M 8 X 16 Z.BIANCA	SCREW DIN 912 PG CL 8.8 M8 X 16 Z. WHITE	VIS TCEI PG DIN 912 CL 8.8 M 8 X 16 GALVANISÉE BLANCHE	SCHRAUBE DIN 912 PG CL 8.8 M8 X 16 Z. WEIß	TORNILLO DIN 912 CL 8.8 M 8 X 16 GALVANIZADO BLANCO
BV14	BV001400	NR	VITE TE TUTTO FILETTO PG DIN 933 CL 8.8 M 8 X 14 Z.BIANCA	SCREW ALL THREAD DIN 933 PG CL 8.8 M 8 X 14 Z. WHITE	VIS ENTIÈREMENT FILETÉE DIN 933 CL 8.8 M 8 X 14 GALVANISATION BLANCHE	SCHRAUBE	TORNILLO

POS	Codice	U.M.	 Descrizione	 Description	 Designation	 Benennung	 Descripción
BV15	BV001500	NR	VITE TCEI PG DIN 912 CL 8.8 M 6 X 45 Z.BIANCA	SCREW DIN 912 M6 X 45 CL 8.8 Z. WHITE	VIS DIN 912 CL 8.8 M 6 X 45 GALVANISATION BLANCHE	SCHRAUBE	TORNILLO
BV16	BV001600	NR	VITE TCEI PG DIN 912 CL 8.8 M 6 X 30 Z.BIANCA	SCREW DIN 912 M6 X 30 CL 8.8 Z. WHITE	VIS TCEI PG DIN 912 CL 8.8 M 6 X 30 Z.BLANC	SCHRAUBE DIN 912 M6 X 30 CL 8.8 Z. WEIß	TORNILLO TCEI PG DIN 912 CL 8.8 M 6 X 30 GALVANIZADO BLANCO
BV17	BV001700	NR	VITE TSPEI PG DIN 7991 CL 10.9 M 6 X 30 Z.BIANCA	SCREW DIN 7991 CL 10.9 M 6 X 30 Z. WHITE	VIS DIN 7991 CL 10.9 M 6 X 30 GALVANISATION BLANCHE	SCHRAUBE	TORNILLO
BV18	BV001800	NR	VITE TE TUTTO FILETTO PG DIN 933 CL 8.8 M 6 X 30 Z.BIANCA	SCREW ALL THREAD DIN 933 PG CL 8.8 M 6 X 30 Z. WHITE	VIS ENTIÈREMENT FILETÉE DIN 933 CL 8.8 M 6 X 30 GALVANISÉE BLANCHE	VOLLGEWINDESCHRAUBE DIN 933 PG CL 8.8 M 6 X 30 Z. WEIß	TORNILLO TOTALMENTE ROSCADO DIN 933 CL 8.8 M 6 X 30 GALVANIZADO BLANCO
BV19	BV001900	NR	VITE TBEI PG ISO 7380 CL 10.9 M 6 X 30 Z.BIANCA	SCREW ISO 7380 CL 10.9 M 6 X 30 Z. WHITE	VIS ISO 7380 CL 10.9 M 6 X 30 GALVANISATION BLANCHE	SCHRAUBE	TORNILLO
BV20	BV002000	NR	VITE TE TUTTO FILETTO PG DIN 933 CL 8.8 M 6 X 12 Z.BIANCA	SCREW ALL THREAD DIN 933 PG CL 8.8 M 6 X 12 Z. WHITE	VIS TE ENTIÈREMENT FILETÉE PG DIN 933 CL 8.8 M 6 X 12 Z.BIANCA	VOLLGEWINDESCHRAUBE DIN 933 PG CL 8.8 M 6 X 12 Z. WEIß	TORNILLO TOTALMENTE ROSCADO PG DIN 933 CL 8.8 M 6 X 12 GALVANIZADO BLANCO
BV21	BV002100	NR	VITE TCEI PG DIN 912 CL 8.8 M 6 X 12 Z.BIANCA	SCREW DIN 912 PG CL 8.8 M 6 X 12 Z. WHITE	VIS DIN 912 CL 8.8 M 6 X 12 GALVANISATION BLANCHE	SCHRAUBE	TORNILLO
BV22	BV002200	NR	VITE TCEI PG DIN 912 CL 8.8 M 5 X 45 Z.BIANCA	SCREW DIN 912 PG CL 8.8 M 5 X 45 Z. WHITE	VIS DIN 912 CL 8.8 M 5 X 45 GALVANISATION BLANCHE	SCHRAUBE	TORNILLO
BV23	BV002300	NR	VITE TE UNF ANSI B18.2.1 GR.5 5/16 X 1" Z.BIANCA	SCREW UNF ANSI B18.2.1 GR.5 5/16 X 1" Z. WHITE	VIS UNF ANSI B18.2.1 GR.5 5/16 X 1" GALVANISATION BLANCHE	SCHRAUBE	TORNILLO
BV24	BV002400	NR	VITE TC CROCE PG DIN 7985 CL 4.8 M 4 X 8 Z.BIANCA	CROSS HEAD SCREW DIN 7985 PG CL 4.8 M 4 X 8 Z. WHITE	VIS TC EN CROIX PG DIN 7985 CL 4.8 M 4 X 8 Z.BLANC	KREUZSCHLITZCHRAUBE DIN 7985 PG CL 4.8 M 4 X 8 Z. WEIß	TORNILLO TC DE CRUZ PG DIN 7985 CL 4.8 M 4 X 8 GALVANIZADO BLANCO
BV25	BV002500	NR	VITE TCEI PG DIN 912 CL 8.8 M 4 X 16 Z.BIANCA	SCREW DIN 912 PG CL 8.8 M 4 X 16 Z. WHITE	VIS DIN 912 CL 8.8 M 4 X 16 GALVANISATION BLANCHE	SCHRAUBE	TORNILLO
BV26	BV002600	NR	VITE TCEI PG DIN 912 CL 8.8 M 6 X 50 Z.BIANCA	SCREW DIN 912 PG CL 8.8 M 6 X 50 Z. WHITE	VIS DIN 912 CL 8.8 M 6 X 50 GALVANISATION BLANCHE	SCHRAUBE	TORNILLO
BV27	BV002700	NR	VITE TSPEI PG DIN 7991 CL 10.9 M 6 X 40 Z.BIANCA	SCREW DIN 7991 CL 10.9 M 6 X 40 Z. WHITE	VIS DIN 7991 CL 10.9 M 6 X 40 GALVANISÉE BLANCHE	SCHRAUBE DIN 7991 CL 10.9 M 6 X 40 Z. WEIß	TORNILLO DIN 7991 CL 10.9 M 6 X 40 GALVANIZADO BLANCO





POS	Codice	U.M.	 Descrizione	 Description	 Designation	 Benennung	 Descripción
BV28	BV002800	NR	VITE TSPEI PG DIN 7991 CL 10.9 M 6 X 25 Z.BIANCA	SCREW DIN 7991 CL 10.9 M 6 X 25 Z. WHITE	VIS TSPEI PG DIN 7991 CL 10.9 M 6 X 25 Z.BLANC	SCHRAUBE DIN 7991 CL 10.9 M 6 X 25 Z. WEIß	TORNILLO TSPEI PG DIN 7991 CL 10.9 M 6 X 25 GALVANIZADO BLANCO
BV29	BV002900	NR	VITE TE TUTTO FILETTO PG DIN 933 CL 8.8 M 6 X 25 Z.BIANCA	SCREW ALL THREAD DIN 933 PG CL 8.8 M 6 X 25 Z. WHITE	VIS TE ENTIÈREMENT FILETÉE PG DIN 933 CL 8.8 M 6 X 25 Z.BLANC	VOLLGEWINDESCHRAUBE DIN 933 PG CL 8.8 M 6 X 25 Z. WEIß	TORNILLO TOTALMENTE ROSCADO PG DIN 933 CL 8.8 M 6 X 25 GALVANIZADO BLANCO
BV30	BV003000	NR	VITE TE TUTTO FILETTO PG DIN 933 CL 8.8 M 6 X 22 Z.BIANCA	SCREW ALL THREAD DIN 933 PG CL 8.8 M 6 X 22 Z. WHITE	VIS TE ENTIÈREMENT FILETÉE PG DIN 933 CL 8.8 M 6 X 22 Z.BLANC	VOLLGEWINDESCHRAUBE DIN 933 PG CL 8.8 M 6 X 22 Z. WEIß	TORNILLO TE TOTALMENTE ROSCADO PG DIN 933 CL 8.8 M 6 X 22 GALVANIZADO BLANCO
BV31	BV003100	NR	VITE TSPEI PG DIN 7991 CL 10.9 M 6 X 20 Z.BIANCA	SCREW DIN 7991 CL 10.9 M 6 X 20 Z. WHITE	VIS TSPEI PG DIN 7991 CL 10.9 M 6 X 20 Z.BLANC	SCHRAUBE DIN 7991 CL 10.9 M 6 X 20 Z. WEIß	TORNILLO TSPEI PG DIN 7991 CL 10.9 M 6 X 20 GALVANIZADO BLANCO
BV32	BV003200	NR	VITE TE TUTTO FILETTO PG DIN 933 CL 8.8 M 6 X 20 Z.BIANCA	SCREW ALL THREAD DIN 933 PG CL 8.8 M 6 X 20 Z. WHITE	VIS TE ENTIÈREMENT FILETÉE PG DIN 933 CL 8.8 M 6 X 20 Z.BLANC	VOLLGEWINDESCHRAUBE DIN 933 PG CL 8.8 M 6 X 20 Z. WEIß	TORNILLO TOTALMENTE ROSCADO PG DIN 933 CL 8.8 M 6 X 20 GALVANIZADO BLANCO
BV33	BV003300	NR	VITE TCEI PG DIN 912 CL 8.8 M 6 X 20 Z.BIANCA	SCREW DIN 912 PG CL 8.8 M 6 X 20 Z. WHITE	VIS TCEI PG DIN 912 CL 8.8 M 6 X 20 Z.BLANC	SCHRAUBE DIN 912 PG CL 8.8 M 6 X 20 Z. WEIß	TORNILLO TCEI PG DIN 912 CL 8.8 M 6 X 20 GALVANIZADO BLANCO
BV34	BV003400	NR	VITE TE TUTTO FILETTO PG DIN 933 CL 8.8 M 6 X 16 Z.BIANCA	SCREW ALL THREAD DIN 933 PG CL 8.8 M 6 X 16 Z. WHITE	VIS TE ENTIÈREMENT FILETÉE G DIN 933 CL 8.8 M 6 X 16 Z.BLANC	VOLLGEWINDESCHRAUBE DIN 933 PG CL 8.8 M 6 X 16 Z. WEIß	TORNILLO TOTALMENTE ROSCADO PG DIN 933 CL 8.8 M 6 X 16 GALVANIZADO BLANCO
BV35	BV003500	NR	VITE TBEI PG ISO 7380 CL 10.9 M 6 X 16 Z.BIANCA	SCREW ISO 7380 CL 10.9 M 6 X 16 Z. WHITE	VIS TBEI PG ISO 7380 CL 10.9 M 6 X 16 Z.BLANC	SCHRAUBE ISO 7380 CL 10.9 M 6 X 16 Z. WEIß	TORNILLO TBEI PG ISO 7380 CL 10.9 M 6 X 16 GALVANIZADO BLANCO
BV36	BV003600	NR	VITE TCEI PG DIN 912 CL 8.8 M 5 X 8 Z.BIANCA	SCREW DIN 912 PG CL 8.8 M 5 X 8 Z. WHITE	VIS DIN 912 CL 8.8 M 5 X 8 GALVANISATION BLANCHE	SCHRAUBE	TORNILLO
BV37	BV003700	NR	VITE TSPEI PG DIN 7991 CL 10.9 M 5 X 60 Z.BIANCA	SCREW DIN 7991 CL 10.9 M 5 X 60 Z. WHITE	VIS DIN 7991 CL 10.9 M 5 X 60 GALVANISATION BLANCHE	SCHRAUBE	TORNILLO
BV38	BV003800	NR	VITE TE PARZIALE FILETTO PG DIN 931 CL 8.8 M 5 X 60 Z.BIANCA	SCREW PARTIAL THREAD DIN 931 PG CL 8.8 M 5 X 60 Z. WHITE	VIS PARTILLEMENT FILETÉE DIN 931 CL 8.8 M 5 X 60 GALVANISATION BLANCHE	SCHRAUBE	TORNILLO
BV39	BV003900	NR	VITE TCEI PG DIN 912 CL 8.8 M 5 X 60 Z.BIANCA	SCREW DIN 912 PG CL 8.8 M 5 X 60 Z. WHITE	VIS DIN 912 CL 8.8 M 5 X 60 GALVANISATION BLANCHE	SCHRAUBE	TORNILLO





POS	Codice	U.M.	 Descrizione	 Description	 Designation	 Benennung	 Descripción
BV40	BV004000	NR	VITE TE PARZIALE FILETTO PG DIN 931 CL 8.8 M 5 X 55 Z.BIANCA	SCREW PARTIAL THREAD DIN 931 PG CL 8.8 M 5 X 55 Z. WHITE	VIS PARTIELLEMENT FILETÉE DIN 931 CL 8.8 M 5 X 55 GALVANISATION BLANCHE	SCHRAUBE	TORNILLO
BV41	BV004100	NR	VITE TE TUTTO FILETTO PG DIN 933 CL 8.8 M 5 X 16 Z.BIANCA	SCREW ALL THREAD DIN 933 PG CL 8.8 M 5 X 16 Z. WHITE	VIS TE ENTIÈREMENT FILETÉE PG DIN 933 CL 8.8 M 5 X 16 Z.BLANC	VOLLGEWINDESCHRAUBE DIN 933 PG CL 8.8 M 5 X 16 Z. WEIß	TORNILLO TOTALMENTE ROSCADO PG DIN 933 CL 8.8 M 5 X 16 GALVANIZADO BLANCO
BV42	BV004200	NR	VITE TC CROCE PG DIN 7985 CL 4.8 M 5 X 16 Z.BIANCA	CROSS HEAD SCREW DIN 7985 PG CL 4.8 M 5 X 16 Z. WHITE	VIS TC EN CROIX PG DIN 7985 CL 4.8 M 5 X 16 Z.BLANC	KREUZSCHLITZSCHRAUBE DIN 7985 PG CL 4.8 M 5 X 16 Z. WEIß	TORNILLO TC DE CRUZ PG DIN 7985 CL 4.8 M 5 X 16 GALVANIZADO BLANCO
BV43	BV004300	NR	VITE TE TUTTO FILETTO PG DIN 933 CL 8.8 M 5 X 12 Z.BIANCA	SCREW ALL THREAD DIN 933 PG CL 8.8 M 5 X 12 Z. WHITE	VIS ENTIÈREMENT FILETÉE DIN 933 CL 8.8 M 5 X 12 GALVANISATION BLANCHE	SCHRAUBE	TORNILLO
BV44	BV004400	NR	VITE TE UNF ANSI B18.2.1 GR.5 5/16 X 1"1/4 Z.BIANCA	SCREW UNF ANSI B18.2.1 GR.5 5/16 X 1 "1/4 Z. WHITE	VIS UNF ANSI B18.2.1 GR.5 5/16 X 1"1/4 GALVANISATION BLANCHE	SCHRAUBE	TORNILLO
BV45	BV004500	NR	VITE TE UNF ANSI B18.2.1 GR.5 5/16 X 1"1/4 Z.BIANCA	SCREW UNF ANSI B18.2.1 GR.5 5/16 X 1 "1/4 Z. WHITE	VIS UNF ANSI B18.2.1 GR.5 5/16 X 1"1/4 GALVANISATION BLANCHE	SCHRAUBE	TORNILLO
BV46	BV004600	NR	VITE TCEI PG DIN 912 CL 8.8 M 4 X 40 Z.BIANCA	SCREW DIN 912 PG CL 8.8 M 4 X 40 Z. WHITE	VIS DIN 912 CL 8.8 M 4 X 40 GALVANISATION BLANCHE	SCHRAUBE	TORNILLO
BV47	BV004700	NR	VITE TRILOB. AUTOFORM. TC CROCE PG DIN 7500-C C15 M 4 X 40 Z.BIANCA	TRILOB SCREW. AUTOFORM. TC CROSS PH DIN 7500-C C 15 M 4 X 40 Z. WHITE	VIS TRILOB. AUTOFORM. TC CROIX PG DIN 7500-C C15 M 4 X 40 GALVANISATION BLANCHE	SCHRAUBE	TORNILLO
BV48	BV004800	NR	VITE TRILOB. AUTOFORM. TC CROCE PG DIN 7500-C C15 M 4 X 20 Z.BIANCA	TRILOB SCREW. AUTOFORM. TC CROSS PG DIN 7500-C C15 M 4 X 20 Z. WHITE	VIS TRILOB. AUTOFORM. TC CROIX PG DIN 7500-C C15 M 4 X 20 GALVANISATION BLANCHE	SCHRAUBE	TORNILLO
BV49	BV004900	NR	VITE TC CROCE PG DIN 7985 CL 4.8 M 4 X 16 Z.BIANCA	CROSS HEAD SCREW DIN 7985 PG CL 4.8 M 4 X 16 Z. WHITE	VIS TC CROIX DIN 7985 CL 4.8 M 4 X 16 GALVANISATION BLANCHE	SCHRAUBE	TORNILLO
BV50	BV005000	NR	VITE AUTOFILETTANTE TE C/BORDINO DIN 6928 C15 4,8X50 Z.BIANCA	TAPPING SCREW TE C / BORDINO DIN 6928 C15 4.8 X50 Z. WHITE	VIS AUTOFILETÉE TE C/BORDINO DIN 6928 C15 4,8X50 GALVANISATION BLANCHE	SCHRAUBE	TORNILLO





POS	Codice	U.M.	 Descrizione	 Description	 Designation	 Benennung	 Descripción
BV51	BV005100	NR	VITE AUTOFILETTANTE TE C/BORDINO DIN 6928 C15 4,8X25 Z.BIANCA	TAPPING SCREW TE C / BORDINO DIN 6928 C15 4.8 X25 Z. WHITE	VIS AUTOFILETÉE TE C/BORDINO DIN 6928 C15 4,8X25 GALVANISATION BLANCHE	SCHRAUBE	TORNILLO
BV52	BV005200	NR	VITE TCEI PG DIN 912 CL 12.9 M 3 X 25 Z.D.BIANCA	SCREW DIN 912 M 3 CL 12.9 X 25 Z.D. WHITE	VIS TCEI PG DIN 912 CL 12.9 M 3 X 25 GALVANISATION BLANCHE	SCHRAUBE	TORNILLO
BV53	BV005300	NR	VITE TSPEI PG DIN 7991 CL 10.9 M 3 X 14 Z.BIANCA	SCREW DIN 7991 CL 10.9 M 3 X 14 Z. WHITE	VIS DIN 7991 CL 10.9 M 3 X 14 GALVANISATION BLANCHE	SCHRAUBLE	TORNILLO
BV54	BV005400	NR	VITE AUTOFIL.TC CROCE DIN 7981 C15 3,5 X 6,5 Z.BIANCA	AUTOFIL.TC CROSS SCREW DIN 7981 C15 3.5 X 6.5 Z. WHITE	VIS AUTOFILETÉE CROIX DIN 7981 C15 3,5 X 6,5 GALVANISATION BLANCHE	SCHRAUBE	TORNILLO
BV55	BV005500	NR	VITE TE PARZIALE FILETTO PG DIN 931 CL 10.9 M 16 X 55	SCREW PARTIAL THREAD DIN 931 PG CL 10.9 M 16 X 55	VIS TE PARTIELLEMENT FILETÉE PG DIN 931 CL 10.9 M 16 X 55	TEILGEWINDESCHRAUBE DIN 931 PG CL 10.9 M 16 X 55	TORNILLO PARCIALMENTE ROSCADO PG DIN 931 CL 10.9 M 16 X 55
BV56	BV005600	NR	VITE TE TUTTO FILETTO PG DIN 933 CL 8.8 M 16 X 40 Z.BIANCA	SCREW ALL THREAD DIN 933 PG CL 8.8 M 16 X 40 Z. WHITE	VIS ENTIÈREMENT FILETÉE DIN 933 CL 8.8 M 16 X 40 GALVANISATION BLANCHE	SCHRAUBE	TORNILLO
BV57	BV005700	NR	VITE TE PARZIALE FILETTO PG DIN 931 CL 10.9 M 16 X 220	SCREW PARTIAL THREAD DIN 931 PG CL 10.9 M 16 X 220	VIS PARTIELLEMENT FILETÉE DIN 931 CL 10.9 M 16 X 220	SCHRAUBE	TORNILLO
BV58	BV005800	NR	VITE TE 8.8 DIN933 M16X20 TESTA ALTA 8 ZN BIANCA	SCREW M16X20 DIN933 8.8 HEAD HIGH 8 ZN WHITE	VIS 8.8 DIN933 M16X20 TÊTE HAUTE 8 GALVANISATION BLANCHE	SCHRAUBE	TORNILLO
BV59	BV005900	NR	VITE TE TUTTO FILETTO PG DIN 933 CL 8.8 M 12 X 16 Z.BIANCA	SCREW ALL THREAD DIN 933 PG CL 8.8 M 12 X 16 Z. WHITE	VIS ENTIÈREMENT FILETÉE DIN 933 CL 8.8 M 12 X 16 GALVANISATION BLANCHE	SCHRAUBE	TORNILLO
BV60	BV006000	NR	VITE TE PARZIALE FILETTO PG DIN 931 CL 8.8 M 12 X 120 Z.BIANCA	SCREW PARTIAL THREAD DIN 931 PG CL 8.8 M 12 X 120 Z. WHITE	VIS PARTIELLEMENT FILETÉE DIN 931 CL 8.8 M 12 X 120 GALVANISATION BLANCHE	SCHRAUBE	TORNILLO
BV61	BV006100	NR	VITE TE PARZIALE FILETTO PG DIN 931 CL 8.8 M 10 X 50 Z.BIANCA	SCREW PARTIAL THREAD DIN 931 PG CL 8.8 M 10 X 50 Z. WHITE	VIS TE PARTIELLEMENT FILETÉE PG DIN 931 CL 8.8 M 10 X 50 Z.BLANC	TEILGEWINDESCHRAUBE DIN 931 PG CL 8.8 M 10 X 50 Z. WEIß	TORNILLO PARCIALMENTE ROSCADO PG DIN 931 CL 8.8 M 10 X 50 GALVANIZADO BLANCO





POS	Codice	U.M.	 Descrizione	 Description	 Designation	 Benennung	 Descripción
BV62	BV006200	NR	VITE TE TUTTO FILETTO PG DIN 933 CL 8.8 M 10 X 35 Z.BIANCA	SCREW ALL THREAD DIN 933 PG CL 8.8 M 10 X 35 Z. WHITE	VIS TE ENTIÈREMENT FILETÉE PG DIN 933 CL 8.8 M 10 X 35 Z.BLANC	VOLLGEWINDESCHRAUBE DIN 933 PG CL 8.8 M 10 X 35 Z. WEIß	TORNILLO TOTALMENTE ROSCADO PG DIN 933 CL 8.8 M 10 X 35 GALVANIZADO BLANCO
BV63	BV006300	NR	VITE TSPEI PG DIN 7991 CL 10.9 M 10 X 30 Z.BIANCA	SCREW DIN 7991 CL 10.9 M 10 X 30 Z. WHITE	VIS DIN 7991 CL 10.9 M 10 X 30 GALVANISATION BLANCHE	SCHRAUBE	TORNILLO
BV64	BV006400	NR	VITE TE TUTTO FILETTO PG DIN 933 CL 8.8 M 10 X 30 Z.BIANCA	SCREW ALL THREAD DIN 933 PG CL 8.8 M 10 X 30 Z. WHITE	VIS TE ENTIÈREMENT FILETÉE PG DIN 933 CL 8.8 M 10 X 30 Z.BLANC	VOLLGEWINDESCHRAUBE DIN 933 PG CL 8.8 M 10 X 30 Z. WEIß	TORNILLO PG DIN 933 CL 8.8 M 10 X 30 GALVANIZADO BLANCO
BV65	BV006500	NR	VITE TCEI PG DIN 912 CL 12.9 M 10 X 25 GEO 321 A	SCREW DIN 912 PG CL 12.9 M 10 X 25 GEO 321 A	VIS DIN 912 PG CL 12.9 M 10 X 25 GEO 321 A	SCHRAUBE DIN 912 PG CL 12.9 M 10 X 25 GEO 321 A	TORNILLO TCEI PG DIN 912 CL 12.9 M 10 X 25 GEO 321 A
BV66	BV006600	NR	VITE TCEI PG DIN 912 CL 8.8 M 10 X 25 Z.BIANCA	SCREW DIN 912 PG CL 8.8 M 10 X 25 Z. WHITE	VIS DIN 912 CL 8.8 M 10 X 25 GALVANISATION BLANCHE	SCHRAUBE	TORNILLO
BV67	BV006700	NR	VITE TE TUTTO FILETTO PG DIN 933 CL 8.8 M 10 X 20 Z.BIANCA	SCREW ALL THREAD DIN 933 PG CL 8.8 M 10 X 20 Z. WHITE	VIS ENTIÈREMENT FILETÉE PG DIN 933 CL 8.8 M 10 X 20 Z.BLANC	VOLLGEWINDESCHRAUBE DIN 933 PG CL 8.8 M 10 X 20 Z. WEIß	TORNILLO TOTALMENTE ROSCADO PG DIN 933 CL 8.8 M 10 X 20 GALVANIZADO BLANCO
BV68	BV006800	NR	VITE TE TUTTO FILETTO PG DIN 933 CL 8.8 M 10 X 18 Z.BIANCA	SCREW ALL THREAD DIN 933 PG CL 8.8 M 10 X 18 Z. WHITE	VIS ENTIÈREMENT FILETÉE DIN 933 PG CL 8.8 M 10 X 18 Z. BLANC	VOLLGEWINDESCHRAUBE DIN 933 PG CL 8.8 M 10 X 18 Z. WEIß	TORNILLO TOTALMENTE ROSCADO PG DIN 933 CL 8.8 M 10 X 18 GALVANIZADO BLANCO
BV69	BV006900	NR	VITE TRILOB. AUTOFORM. TSP CROCE PG DIN 7500-M C15 M 5 X 16 Z.BIANCA	TRILOB SCREW. AUTOFORM. TSP CROSS PG DIN 7500-M C15 M 5 X 16 Z. WHITE	VIS TRILOB. AUTOFORM. TSP CROIX PG DIN 7500-M C15 M 5 X 16 GALVANISATION BLANCHE	SCHRAUBE	TORNILLO
BV70	BV007000	NR	VITE TE PARZIALE FILETTO PG DIN 931 CL 8.8 M 8 X 70 Z.BIANCA	SCREW PARTIAL THREAD DIN 931 PG CL 8.8 M 8 X 70 Z. WHITE	VIS PARTIELLEMENT FILETÉE DIN 931 PG CL 8.8 M 8 X 70 Z. BLANC	TEILGEWINDESCHRAUBE DIN 931 PG CL 8.8 M 8 X 70 Z. WEIß	TORNILLO PARCIALMENTE ROSCADO PG DIN 931 CL 8.8 M 8 X 70 GALVANIZADO BLANCO
BV71	BV007100	NR	VITE TE PARZIALE FILETTO PG DIN 931 CL 8.8 M 8 X 65 Z.BIANCA	SCREW PARTIAL THREAD DIN 931 PG CL 8.8 M 8 X 65 Z. WHITE	VIS PARTIELLEMENT FILETÉE DIN 931 CL 8.8 M 8 X 65 GALVANISÉE BLANCHE	TEILGEWINDESCHRAUBE DIN 931 PG CL 8.8 M 8 X 65 Z. WEIß	TORNILLO PARCIALMENTE ROSCADO DIN 931 CL 8.8 M 8 X 65 GALVANIZADO BLANCO
BV72	BV007200	NR	VITE TE PARZIALE FILETTO PG DIN 931 CL 8.8 M 6 X 55 Z.BIANCA	SCREW PARTIAL THREAD DIN 931 PG CL 8.8 M 6 X 55 Z. WHITE	VIS PARTIELLEMENT FILETÉE DIN 931 CL 8.8 M 6 X 55 GALVANISÉE BLANCHE	TEILGEWINDESCHRAUBE DIN 931 PG CL 8.8 M 6 X 55 Z. WEIß	TORNILLO PARCIALMENTE ROSCADO DIN 931 CL 8.8 M 6 X 55 GALVANIZADO BLANCO





POS	Codice	U.M.	 Descrizione	 Description	 Designation	 Benennung	 Descripción
BV73	BV007300	NR	VITE TCEI PG DIN 912 CL 8.8 M 6 X 55 Z.BIANCA	SCREW DIN 912 PG CL 8.8 M 6 X 55 Z. WHITE	VIS TCEI PG DIN 912 CL 8.8 M 6 X 55 GALVANISATION BLANCHE	SCHRAUBE	TORNILLO
BV74	BV007400	NR	VITE TCEI PG DIN 912 CL 8.8 M 6 X 16 Z.BIANCA	SCREW DIN 912 PG CL 8.8 M 6 X 16 Z. WHITE	VIS DIN 912 CL 8.8 M 6 X 16 GALVANISATION BLANCHE	SCHRAUBE	TORNILLO
BV75	BV007500	NR	VITE TSPEI PG DIN 7991 CL 10.9 M 6 X 10 Z.BIANCA	SCREW DIN 7991 CL 10.9 M 6 X 10 Z. WHITE	VIS DIN 7991 CL 10.9 M 6 X 10 GALVANISATION BLANCHE	SCHRAUBE	TORNILLO
BV76	BV007600	NR	VITE TCEI PG DIN 912 CL 8.8 M 5 X 55 Z.BIANCA	SCREW DIN 912 PG CL 8.8 M 5 X 55 Z. WHITE	VIS DIN 912 CL 8.8 M 5 X 55 GALVANISATION BLANCHE	SCHRAUBE	TORNILLO
BV77	BV007700	NR	VITE TC CROCE PG DIN 7985 CL 4.8 M 6 X 16 Z.BIANCA	CROSS HEAD SCREW DIN 7985 PG CL 4.8 M 6 X 16 Z. WHITE	VIS DIN 7985 CL 4.8 M 6 X 16 GALVANISATION BLANCHE	SCHRAUBE	TORNILLO
BV78	BV007800	NR	VITE TRILOB. AUTOFORM. TC CROCE PG DIN 7500-C C15 M 5 X 12 Z.BIANCA	TRILOB SCREW. AUTOFORM. TC CROSS PG DIN 7500-C C15 M 5 X 12 Z. WHITE	VIS TRILOB. AUTOFORM. TC CROIX PG DIN 7500-C C15 M 5 X 12 GALVANISATION BLANCHE	SCHRAUBE	TORNILLO
BV79	BV007900	NR	VITE TE TUTTO FILETTO PG DIN 933 CL 8.8 M 4 X 35 Z.BIANCA	SCREW ALL THREAD DIN 933 PG CL 8.8 M 4 X 35 Z. WHITE	VIS ENTIÈREMENT FILETÉE DIN 933 CL 8.8 M 4 X 35 GALVANISATION BLANCHE	SCHRAUBE	TORNILLO
BV80	BV008000	NR	VITE AUTOFILETTANTE TE C/BORDINO DIN 6928 C15 4,8X35 Z.BIANCA	TAPPING SCREW TE C / BORDINO DIN 6928 C15 4.8 X35 Z. WHITE	VIS AUTOFILETÉE TE C/BORDINO DIN 6928 C15 4,8X35 GALVANISATION BLANCHE	SCHRAUBE	TORNILLO
BV81	BV008100	NR	VITE TCEI PG DIN 912 CL 12.9 M 3 X 14 Z.D.BIANCA	SCREW DIN 912 M 3 CL 12.9 X 14 Z.D. WHITE	VIS DIN 912 CL 12.9 M 3 X 14 GALVANISATION BLANCHE	SCHRAUBE	TORNILLO
BV82	BV008200	NR	VITE TE PARZIALE FILETTO PG DIN 931 CL 8.8 M 16 X 70 Z.BIANCA	SCREW PARTIAL THREAD DIN 931 PG CL 8.8 M 16 X 70 Z. WHITE	VIS PARTIELLEMENT FILETÉE PG DIN 931 CL 8.8 M 16 X 70 GALVANISATION BLANCHE	SCHRAUBE	TORNILLO
BV83	BV008300	NR	VITE TE PARZIALE FILETTO PG DIN 931 CL 8.8 M 16 X 260 Z.BIANCA	SCREW PARTIAL THREAD DIN 931 PG CL 8.8 M 16 X 260 Z. WHITE	VIS PARTIELLEMENT FILETÉE PG DIN 931 CL 8.8 M 16 X 260 GALVANISATION BLANCHE	SCHRAUBE	TORNILLO
BV84	BV008400	NR	VITE TE PARZIALE FILETTO PG DIN 931 CL 8.8 M 12 X 110 Z.BIANCA	SCREW PARTIAL THREAD DIN 931 PG CL 8.8 M 12 X 110 Z. WHITE	VIS PARTIELLEMENT FILETÉE DIN 931 CL 8.8 M 12 X 110 GALVANISATION BLANCHE	SCHRAUBE	TORNILLO





POS	Codice	U.M.	 Descrizione	 Description	 Designation	 Benennung	 Descripción
BV85	BV008500	NR	VITE TE TUTTO FILETTO PG DIN 933 CL 8.8 M 10 X 40 Z.BIANCA	SCREW THREAD DIN 933 PG CL 8.8 M 10 X 40 Z. WHITE	VIS FILETÉE DIN 933 PG CL 8.8 M 10 X 40 Z. BLANC	TEILGEWINDESCHRAUBE DIN 933 PG CL 8.8 M 10 X 40 Z. WEIß	TORNILLO ROSCADO PG DIN 933 CL 8.8 M 10 X 40 GALVANIZADO BLANCO
BV86	BV008600	NR	VITE TCEI PG DIN 912 CL 8.8 M 8 X 65 Z.BIANCA	SCREW DIN 912 PG CL 8.8 M 8 X 65 Z. WHITE	VIS DIN 912 CL 8.8 M 8 X 65 GALVANISATION BLANCHE	SCHRAUBE	TORNILLO
BV87	BV008700	NR	VITE TCEI PG DIN 912 CL 8.8 M 8 X 20 Z.BIANCA	SCREW DIN 931 PG CL 8.8 M 10 X 40 Z. WHITE	VIS DIN 931 PG CL 8.8 M 10 X 40 Z. BLANC	SCHRAUBE DIN 931 PG CL 8.8 M 10 X 40 Z. WEIß	TORNILLO TCEI PG DIN 912 CL 8.8 M 8 X 20 GALVANIZADO BLANCO
BV88	BV008800	NR	VITE TCEI PG DIN 912 CL 10.9 M 10 X 18 Z.BIANCA	SCREW DIN 912 PG CL 10.9 M 10 X 18 Z. WHITE	VIS DIN 912 CL 10.9 M 10 X 18 GALVANISATION BLANCHE	SCHRAUBE	TORNILLO
BV89	BV008900	NR	VITE TCEI PG DIN 912 CL 8.8 M 8 X 70 Z.BIANCA	SCREW DIN 912 PG CL 8.8 M 8 X 70 Z. WHITE	VIS DIN 912 CL 8.8 M 8 X 70 GALVANISATION BLANCHE	SCHRAUBE	TORNILLO
BV91	BV009100	NR	VITE TE PARZIALE FILETTO PG DIN 931 CL 8.8 M 6 X 40 Z.BIANCA	SCREW PARTIAL THREAD DIN 931 PG CL 8.8 M 6 X 40 Z. WHITE	VIS FILETÉE DIN 931 PG CL 8.8 M 6 X 40 Z. BLANC	VOLLGEWINDESCHRAUBE DIN 931 PG CL 8.8 M 6 X 40 Z. WEIß	TORNILLO PG DIN 931 CL 8.8 M 6 X 40 GALVANIZADO BLANCO
BV92	BV009200	NR	VITE TE TUTTO FILETTO PG DIN 933 CL 8.8 M 10 X 60 Z.BIANCA	SCREW ALL THREAD DIN 933 PG CL 8.8 M 10 X 60 Z. WHITE	VIS	SCHRAUBE	TORNILLO
BV93	BV009300	NR	VITE TSPEI PG DIN 7991 CL 10.9 M 5 X 20 Z.BIANCA	SCREW DIN 7991 CL 10.9 M 5 X 20 Z. WHITE	VIS DIN 7991 CL 10.9 M 5 X 20 GALVANISATION BLANCHE	SCHRAUBE	TORNILLO
BV94	BV009400	NR	VITE TC CROCE PG DIN 7985 CL 4.8 M 4 X 12 Z.BIANCA	CROSS HEAD SCREW DIN 7985 PG CL 4.8 M 4 X 12 Z. WHITE	VIS CROIX DIN 7985 CL 4.8 M 4 X 12 GALVANISATION BLANCHE	SCHRAUBE	TORNILLO
BV95	BV009500	NR	VITE TE TUTTO FILETTO PG DIN 933 CL 8.8 M 4 X 12 Z.BIANCA	SCREW ALL THREAD DIN 933 PG CL 8.8 M 4 X 12 Z. WHITE	VIS ENTIÈREMENT FILETÉE DIN 933 CL 8.8 M 4 X 12 GALVANISATION BLANCHE	SCHRAUBE	TORNILLO
BV96	BV009600	NR	VITE TCEI PG DIN 912 CL 12.9 M 12 X 30 DAC 320A	SCREW DIN 912 CL 12.9 M 12 X 30 DAC 320A	VIS DIN 912 CL 12.9 M 12 X 30 DAC 320A	SCHRAUBE DIN 912 CL 12.9 M 12 X 30 DAC 320A	TORNILLO TCEI PG DIN 912 CL 12.9 M 12 X 30 DAC 320A
BV97	BV009700	NR	VITE AUTOFIL.TESTA MEZZA TONDA C15 4,8 X 13 Z.BIANCA	HALF ROUND HEAD SELF TAPPING SCREW C15 4,8 X 13	VIS AUTOFILETÉE TÊTE DEMI- RONDE C15 4,8 X 13 GALVANISATION BLANCHE	SCHRAUBE	TORNILLO

POS	Codice	U.M.	 Descrizione	 Description	 Designation	 Benennung	 Descripción
BV98	BV009800	NR	VITE TC CROCE PG DIN 7985 CL 4.8 M 4 X 14 Z.BIANCA	SCREW DIN 7985 CL 4.8 M 4 X 14	VIS EN CROIX PG DIN 7985 CL 4.8 M 4 X 14 GALVANISÉE BLANCHE	KREUZSCHLITZSCHRAUBE DIN 7985 CL 4.8 M 4 X 14	TORNILLO CRUZ 7985 CL 4.8 M 4 X 14 GALVANIZADO BLANCO
BV99	BV009900	NR	VITE TE PARZIALE FILETTO PG DIN 931 CL 8.8 M 5 X 65 Z.BIANCA	SCREW PARTIAL THREAD DIN 931 PG CL 8.8 M 5 X 65 Z. WHITE	VIS PARTIELLEMENT FILETÉE DIN 931 CL 8.8 M 5 X 65 GALVANISATION BLANCHE	SCHRAUBE	TORNILLO
BV100	BV010000	NR	VITE AUTOFIL.TESTA MEZZA TONDA C15 4,8 X 16 Z.BIANCA	HALF ROUND HEAD SELF TAPPING SCREW C15 4,8 X 16	VIS AUTOFILETÉE TÊTE DEMI-RONDE C15 4,8 X 16 GALVANISATION BLANCHE	SCHRAUBE	TORNILLO
BV101	BV010100	NR	VITE TSPEI PG DIN 7991 CL 10.9 M 8 X 25 Z.BIANCA	SCREW DIN 7991 CL 10.9 M 8 X 25 Z. WHITE	VIS DIN 7991 CL 10.9 M 8 X 25 GALVANISATION BLANCHE		
BV102	BV010200	NR	VITE TCEI PG DIN 912 CL 8.8 M 4 X 30 Z.BIANCA	SCREW DIN 912 PG CL 8.8 M 4 X 30 WHITE Z	VIS DIN 912 CL 8.8 M 4 X 30 GALVANISATION BLANCHE	SCHRAUBE	TORNILLO
BV103	BV010300	NR	VITE TSPEI PG DIN 7991 CL 10.9 M 5 X 16 Z.BIANCA	SCREW DIN 7991 CL 10.9 M 5 X 16 Z. WHITE	VIS DIN 7991 CL 10.9 M 5 X 16 GALVANISATION BLANCHE	SCHRAUBE	TORNILLO
BV104	BV010400	NR	VITE TCEI BASSA PG DIN 7984 CL 10.9 M 12 X 18 Z.D.BIANCA	SCREW DIN 7984 LOW PG CL 10.9 M 12 X 18 Z. D. WHITE	VIS BASSE DIN 7984 CL 10.9 M 12 X 18 Z. BLANCHE	SCHRAUBE	TORNILLO
BV105	BV010500	NR	VITE TE PARZIALE FILETTO PG DIN 931 CL 8.8 M 12 X 75 Z.BIANCA	SCREW PARTIAL THREAD DIN 931 PG CL 8.8 M 12 X 75 Z. WHITE	VIS PARTIELLEMENT FILETÉE DIN 931 CL 8.8 M 12 X 75 GALVANISATION BLANCHE	SCHRAUBE	TORNILLO
BV106	BV010600	NR	VITE TE TUTTO FILETTO PG DIN 933 CL 8.8 M 8 X 22 Z.BIANCA	SCREW ALL THREAD DIN 933 PG CL 8.8 M 8 X 22 Z. WHITE	VIS ENTIÈREMENT FILETÉE DIN 933 PG CL 8.8 M 8 X 22 Z. BLANC	VOLLGEWINDESCHRAUBE DIN 933 PG CL 8.8 M 8 X 22 Z. WEIß	TORNILLO TOTALMENTE ROSCADO PG DIN 933 CL 8.8 M 8 X 22 GALVANIZADO BLANCO
BV107	BV010700	NR	VITE TE TUTTO FILETTO PG DIN 933 CL 8.8 M 6 X 35 Z.BIANCA	SCREW ALL THREAD DIN 933 PG CL 8.8 M 6 X 35 Z. WHITE	VIS ENTIÈREMENT FILETÉE DIN 933 CL 8.8 M 6 X 35 GALVANISATION BLANCHE	SCHRAUBE	TORNILLO
BV108	BV010800	NR	VITE TE PARZIALE FILETTO PG DIN 931 CL 8.8 M 4 X 45 Z.BIANCA	SCREW PARTIAL THREAD DIN 931 PG CL 8.8 M 4 X 45 Z. WHITE	VIS PARTIELLEMENT FILETÉE DIN 931 CL 8.8 M 4 X 45 GALVANISATION BLANCHE	SCHRAUBE	TORNILLO
BV109	BV010900	NR	VITE TE TUTTO FILETTO PG DIN 933 CL 10.9 M 16 X 45 Z.D.BIANCA	SCREW ALL THREAD DIN 933 PG CL 10.9 M 16 X 45 ZD WHITE	VIS ENTIÈREMENT FILETÉE DIN 933 CL 10.9 M 16 X 45 GALVANISATION BLANCHE	SCHRAUBE	TORNILLO





POS	Codice	U.M.	 Descrizione	 Description	 Designation	 Benennung	 Descripción
BV110	BV011000	NR	VITE TE PARZIALE FILETTO PG DIN 931 CL 10.9 M 16 X 100	SCREW PARTIAL THREAD DIN 931 PG CL 10.9 M 16 X 100	VIS PARTIELLEMENT FILETÉE DIN 931 CL 10.9 M 16 X 100	SCHRAUBE	TORNILLO
BV111	BV011100	NR	VITE TE PARZIALE FILETTO PG DIN 931 CL 10.9 M 16 X 105	SCREW PARTIAL THREAD DIN 931 PG CL 10.9 M 16 X 105	VIS PARTIELLEMENT FILETÉE DIN 931 CL 10.9 M 16 X 105	SCHRAUBE	TORNILLO
BV112	BV011200	NR	VITE TE TUTTO FILETTO PG DIN 933 CL 8.8 M 10 X 25 Z.BIANCA	SCREW ALL THREAD DIN 933 PG CL 8.8 M 10 X 25 Z. WHITE	VIS ENTIÈREMENT FILETÉE DIN 933 PG CL 8.8 M 10 X 25 Z. BLANC	VOLLGEWINDESCHRAUBE DIN 933 PG CL 8.8 M 10 X 25 Z. WEIß	TORNILLO TOTALMENTE ROSCADO PG DIN 933 CL 8.8 M 10 X 25 GALVANIZADO BLANCO
BV113	BV011300	NR	VITE TSPEI PG DIN 7991 CL 10.9 M 6 X 50 Z.BIANCA	TSPEI PG SCREW DIN 7991 CL 10.9 M 6 X 50 Z. WHITE	VIS DIN 7991 CL 10.9 M 6 X 50 Z. BLANC	TSPEI PG SCHRAUBE DIN 7991 CL 10.9 M 6 X 50 Z. WEIß	TORNILLO TSPEI PG DIN 7991 CL 10.9 M 6 X 50 GALVANIZADO BLANCO
BV114	BV011400	NR	VITE TSPEI PG DIN 7991 CL 10.9 M 8 X 25 Z.BIANCA	TSPEI PG SCREW DIN 7991 CL 10.9 M 8 X 25 Z. WHITE	VIS DIN 7991 CL 10.9 M 8 X 25 GALVANISATION BLANCHE	SCHRAUBE	TORNILLO
BV115	BV011500	NR	VITE TE TUTTO FILETTO PG DIN 933 CL 8.8 M 10 X 45 Z.BIANCA	SCREW ALL THREAD DIN 933 PG CL 8.8 M 10 X 45 Z. WHITE	VIS ENTIÈREMENT FILETÉE DIN 933 CL 8.8 M 10 X 45 GALVANISATION BLANCHE	SCHRAUBE	TORNILLO
BV116	BV011600	NR	VITE TE TUTTO FILETTO PG DIN 933 CL 8.8 M 5 X 8 Z.BIANCA	SCREW ALL THREAD DIN 933 PG CL 8.8 M 5 X 8 Z. WHITE	VIS ENTIÈREMENT FILETÉE DIN 933 CL 8.8 M 5 X 8 GALVANISATION BLANCHE	SCHRAUBE	TORNILLO
BV117	BV011700	NR	VITE TE TUTTO FILETTO PG DIN 933 CL 8.8 M 8 X 18 Z.BIANCA	SCREW ALL THREAD DIN 933 PG CL 8.8 M 8 X 18 Z. WHITE	VIS ENTIÈREMENT FILETÉE DIN 933 CL 8.8 M 8 X 18 GALVANISATION BLANCHE	SCHRAUBE	TORNILLO
BV118	BV011800	NR	VITE TE TUTTO FILETTO PG DIN 933 CL 8.8 M 8 X 40 Z.BIANCA	SCREW ALL THREAD DIN 933 PG CL 8.8 M 8 X 40 Z. WHITE	VIS ENTIÈREMENT FILETÉE DIN 933 PG CL 8.8 M 8 X 40 Z. BLANC	VOLLGEWINDESCHRAUBE DIN 933 PG CL 8.8 M 8 X 40 Z. WEIß	TORNILLO DIN 933 CL 8.8 M 8 X 40 GALVANIZADO BLANCO
BV119	BV011900	NR	VITE TCEI PG DIN 912 CL 8.8 M 8 X 100 Z.BIANCA	SCREW DIN 912 PG CL 8.8 M 8 X 100 Z. WHITE	VIS DIN 912 CL 8.8 M 8 X 100 GALVANISATION BLANCHE	SCHRAUBE	TORNILLO
BV120	BV012000	NR	VITE TCEI PG DIN 912 CL 8.8 M 8 X 110 Z.BIANCA	SCREW DIN 912 PG CL 8.8 M 8 X 110 Z. WHITE	VIS DIN 912 CL 8.8 M 8 X 110 GALVANISATION BLANCHE	SCHRAUBE	TORNILLO
BV121	BV012100	NR	VITE TE PARZIALE FILETTO PG DIN 931 CL 8.8 M 5 X 75 Z.BIANCA	SCREW PARTIAL THREAD DIN 931 PG CL 8.8 M 5 X 75 Z. WHITE	VIS PARTIELLEMENT FILETÉE DIN 931 CL 8.8 M 5 X 75 GALVANISATION BLANCHE	SCHRAUBE	TORNILLO





POS	Codice	U.M.	 Descrizione	 Description	 Designation	 Benennung	 Descripción
BV122	BV012200	NR	VITE TE PARZIALE FILETTO PG DIN 931 CL 8.8 M 12 X 130 Z.BIANCA	SCREW PARTIAL THREAD DIN 931 PG CL 8.8 M 12 X 130 Z. WHITE	VIS PARTIELLEMENT FILETÉE DIN 931 CL 8.8 M 12 X 130 GALVANISATION BLANCHE	SCHRAUBE	TORNILLO
BV123	BV012300	NR	VITE TC CROCE PG DIN 7985 CL 4.8 M 4 X 8 Z.BIANCA	CROSS HEAD SCREW DIN 7985 PG CL 4.8 M 4 X 8 Z. WHITE	VIS TC EN CROIX PG DIN 7985 CL 4.8 M 4 X 8 Z.BLANC	KREUZSCHLITZCHRAUBE DIN 7985 PG CL 4.8 M 4 X 8 Z. WEIß	TORNILLO TC DE CRUZ PG DIN 7985 CL 4.8 M 4 X 8 GALVANIZADO BLANCO
BV124	BV012400	NR	VITE TCEI PG DIN 912 CL 8.8 M 6 X 40 Z.BIANCA	SCREW DIN 912 PG CL 8.8 M 6 X 40 Z. WHITE	VIS DIN 912 CL 8.8 M 6 X 40 GALVANISATION BLANCHE	SCHRAUBE	TORNILLO
BV125	BV012500	NR	VITE TE TUTTO FILETTO PG DIN 933 CL 8.8 M 4 X 20 Z.BIANCA	SCREW ALL THREAD DIN 933 PG CL 8.8 M 4 X 20 Z. WHITE	VIS ENTIÈREMENT FILETÉE DIN 933 CL 8.8 M 4 X 20 GALVANISATION BLANCHE	SCHRAUBE	TORNILLO
BV126	BV012600	NR	VITE TE UNC ANSI B18.2.1 GR.5 3/8 X 1" Z.BIANCA	SCREW UNC ANSI B18.2.1 GR.5 3/8 X 1" Z. WHITE	VIS UNC ANSI B18.2.1 GR.5 3/8 X 1" GALVANISATION BLANCHE	SCHRAUBE	TORNILLO
BV127	BV012700	NR	VITE TE UNC ANSI B18.2.1 GR.5 3/8 X 1" 1/4Z.BIANCA	SCREW UNC ANSI B18.2.1 GR.5 3/8 X 1" 1/4 Z. WHITE	VIS UNC ANSI B18.2.1 GR.5 3/8 X 1" 1/4 GALVANISATION BLANCHE	SCHRAUBE	TORNILLO
BV128	BV012800	NR	VITE TE TUTTO FILETTO PG DIN 933 CL 8.8 M 4 X 16 Z.BIANCA	SCREW ALL THREAD DIN 933 PG CL 8.8 M 4 X 16 Z. WHITE	VIS ENTIÈREMENT FILETÉE DIN 933 CL 8.8 M 4 X 16 GALVANISATION BLANCHE	SCHRAUBE	TORNILLO
BV129	BV012900	NR	VITE TCEI PG DIN 912 CL 8.8 M 5 X 16 Z.BIANCA	SCREW DIN 912 PG CL 8.8 M 5 X 16 Z. WHITE	VIS DIN 912 CL 8.8 M 5 X 16 GALVANISATION BLANCHE	SCHRAUBE	TORNILLO
BV130	BV013000	NR	VITE TCEI PG DIN 912 CL 8.8 M 3 X 12 Z.BIANCA	SCREW DIN 912 PG CL 8.8 M 3 X 12 Z. WHITE	VIS DIN 912 CL 8.8 M 3 X 12 GALVANISATION BLANCHE	SCHRAUBE	TORNILLO
BV131	BV013100	NR	VITE TSPEI PG DIN 7991 CL 10.9 M 5 X 30 Z.BIANCA	TSPEI PG SCREW DIN 7991 CL 10.9 M 5 X 30 Z. WHITE	VIS DIN 7991 CL 10.9 M 5 X 30 GALVANISATION BLANCHE	SCHRAUBE	TORNILLO
BV132	BV013200	NR	VITE TSPEI PG DIN 7991 CL 10.9 M 5 X 55 Z.BIANCA	TSPEI PG SCREW DIN 7991 CL 10.9 M 5 X 55 Z. WHITE	VIS DIN 7991 CL 10.9 M 5 X 55 GALVANISATION BLANCHE	SCHRAUBE	TORNILLO
BV133	BV013300	NR	VITE TE TUTTO FILETTO PG DIN 933 CL 8.8 M 3 X 25 Z.BIANCA	SCREW ALL THREAD DIN 933 PG CL 8.8 M 3 X 25 Z. WHITE	VIS ENTIÈREMENT FILETÉE DIN 933 CL 8.8 M 3 X 25 GALVANISATION BLANCHE	SCHRAUBE	TORNILLO
BV134	BV013400	NR	VITE TE PARZIALE FILETTO PG DIN 931 CL 8.8 M 10 X 65 Z.BIANCA	SCREW PARTIAL THREAD DIN 931 PG CL 8.8 M 10 X 65 Z. WHITE	VIS PARTIELLEMENT FILETÉE DIN 931 CL 8.8 M 10 X 65 GALVANISATION BLANCHE	SCHRAUBE	TORNILLO





POS	Codice	U.M.	 Descrizione	 Description	 Designation	 Benennung	 Descripción
BV135	BV013500	NR	VITE TCEI PG DIN 912 CL 8.8 M 12 X 50	SCREW DIN 912 CL 9.8 M 12 X 50	VIS DIN 912 CL 8.8 M 12 X 50	SCHRAUBE DIN 912 CL 8.8 M 12 X 50	TORNILLO DIN 912 CL 8.8 M 12 X 50
BV136	BV013600	NR	VITE TSPEI PG DIN 7991 CL 10.9 M 5 X 25 Z.BIANCA	TSPEI PG SCREW DIN 7991 CL 10.9 M 5 X 25 Z. WHITE	VIS DIN 7991 CL 10.9 M 5 X 25 GALVANISATION BLANCHE	SCHRAUBE	TORNILLO
BV137	BV013700	NR	VITE TCEI PG DIN 912 CL 8.8 M 8 X 30	SCREW DIN 912 CL 8.8 M 8 X 30	VIS DIN 912 CL 8.8 M 8 X 30	SCHRAUBE DIN 912 CL 8.8 M 8 X 30	TORNILLO DIN 912 CL 8.8 M 8 X 30
BV138	BV013800	NR	VITE TC CROCE PG DIN 7985 CL 4.8 M 5 X 10 Z.BIANCA	SCREW DIN 7985 CL 4.8 M 5 X 10	VIS CROIX DIN 7985 CL 4.8 M 5 X 10 GALVANISATION BLANCHE	SCHRAUBE	TORNILLO
BV139	BV013900	NR	VITE TCEI PG DIN 912 CL 8.8 M 4 X 25 Z. BIANCA	SCREW DIN 912 CL 8.8 M 4 X 25 Z.WITHE	VIS DIN 912 CL 8.8 M 4 X 25 GALVANISATION BLANCHE	SCHRAUBE	TONILLO
BV140	BV014000	NR	VITE TE PARZIALE FILETTO PG DIN 931 CL 8.8 M 5 X 70 Z.BIANCA	SCREW PARTIAL THREAD DIN 931 PG CL 8.8 M 5 X 70 Z. WHITE	VIS PARTIELLEMENT FILETÉE DIN 931 CL 8.8 M 5 X 70 GALVANISATION BLANCHE	SCHRAUBE	TORNILLO
BV141	BV014100	NR	VITE TE PARZIALE FILETTO PG DIN 931 CL 8.8 M 12 X 90 Z.BIANCA	SCREW PARTIAL THREAD DIN 931 PG CL 8.8 M 12 X 90 Z. WHITE	VIS PARTIELLEMENT FILETÉE DIN 931 CL 8.8 M 12 X 90 GALVANISATION BLANCHE	SCHRAUBE	TORNILLO
BV142	BV014200	NR	VITE TE PARZIALE FILETTO PG DIN 931 CL 8.8 M 8 X 55 Z.BIANCA	SCREW PARTIAL THREAD DIN 931 PG CL 8.8 M 8 X 55 Z. WHITE	VIS PARTIELLEMENT FILETÉE DIN 931 CL 8.8 M 8 X 55 GALVANISATION BLANCHE	SCHRAUBE	TORNILLO
BV143	BV014300	NR	VITE TSPEI PG DIN 7991 CL 10.9 M 10 X 20 Z.BIANCA	TSPEI PG SCREW DIN 7991 CL 10.9 M 10 X 20 Z. WHITE	VIS DIN 7991 CL 10.9 M 10 X 20 GALVANISATION BLANCHE	SCHRAUBE	TORNILLO
BV144	BV014400	NR	VITE TE TUTTO FILETTO PG DIN 933 CL 8.8 M 12 X 20 Z.BIANCA	SCREW ALL THREAD DIN 933 PG CL 8.8 M 12 X 20 Z. WHITE	VIS ENTIÈREMENT FILETÉE DIN 933 CL 8.8 M 12 X 20 GALVANISATION BLANCHE	SCHRAUBE	TORNILLO
BV145	BV014500	NR	VITE TE TUTTO FILETTO PG DIN 933 CL 8.8 M 12 X 35 Z.BIANCA	SCREW ALL THREAD DIN 933 PG CL 8.8 M 12 X 35 Z. WHITE	VIS ENTIÈREMENT FILETÉE DIN 933 PG CL 8.8 M 12 X 35 Z. BLANC	VOLLGEWINDESCHRAUBE DIN 933 PG CL 8.8 M 12 X 35 Z. WEIß	TORNILLO TOTALMENTE ROSCADO DIN 933 CL 8.8 M 12 X 35 GALVANIZADO BLANCO
BV146	BV014600	NR	VITE TE TUTTO FILETTO PF DIN 961 CL 10.9 M 10 X 1,25 X 25 Z.D.BIANCO	ALL PF THREAD HEX HEAD SCREW DIN 961 CL 10.9 M 10 X 1,25 X 25 Z.BIANCA	VIS ENTIÈREMENT FILETÉE DIN 961 CL 10.9 M 10 X 1,25 X 25 GALVANISÉE BLANCHE	VOLLGEWINDESCHRAUBE DIN 961 CL 10.9 M 10 X 1,25 X 25 Z. WEIß	TORNILLO TOTALMENTE ROSCADO DIN 961 CL 10.9 M 10 X 1,25 X 25 GALVANIZADO BLANCO

POS	Codice	U.M.	 Descrizione	 Description	 Designation	 Benennung	 Descripción
BV147	BV014700	NR	VITE TSPEI PARZIALE FILETTO PG DIN 7991 CL 10.9 M 12 X 90 Z.BIANCA	TSPEI PARTIAL THREAD PG SCREW DIN 7991 CL 10.9 M12 X 90 Z. WHITE	VIS TSPEI PG DIN 7991 CL 10.9 M 12 X 90 GALVANISATION BLANCHE	SCHRAUBE	TORNILLO
BV148	BV014800	NR	VITE TSPEI PG DIN 7991 CL 10.9 M 6 X 16 Z.BIANCA	TSPEI PG SCREW DIN 7991 CL 10.9 M6 X 16 Z. WHITE	VIS TSPEI PG DIN 7991 CL 10.9 M 6 X 16 GALVANISATION BLANCHE	SCHRAUBE	TORNILLO
BV149	BV014900	NR	VITE TBEI PG ISO 7380 CL 10.9 M 6 X 20 Z.BIANCA	HEX SOCKET SCREW ISO 7380 PG CL 10.9 M 6 X 20 Z. WHITE	VIS ISO 7380 CL 10.9 M 6 X 20 GALVANISATION BLANCHE	SCHRAUBE	TORNILLO
BV150	BV015000	NR	VITE TE TUTTO FILETTO PG DIN 933 CL 10.9 M 14 X 40 Z.BIANCA	SCREW ALL THREAD DIN 933 PG CL 10.9 M 14 X 40 Z. WHITE	VIS ENTIÈREMENT FILETÉE DIN 933 CL 10.9 M 14 X 40 GALVANISATION BLANCHE	SCHRAUBE	TORNILLO
BV151	BV015100	NR	VITE TE PARZIALE FILETTO PG DIN 931 CL 8.8 M 10 X 85 Z.BIANCA	SCREW PARTIAL THREAD DIN 931 PG CL 8.8 M 10 X 85 Z. WHITE	VIS PARTIELLEMENT FILETÉE DIN 931 PG CL 8.8 M 10 X 85 Z. BLANC	TEILGEWINDESCHRAUBE DIN 931 PG CL 8.8 M 10 X 85 Z. WEIß	TORNILLO PARCIALMENTE ROSCADO PG DIN 931 CL 8.8 M 10 X 85 GALVANIZADO BLANCO
BV152	BV015200	NR	VITE TE PARZIALE FILETTO PG DIN 931 CL 8.8 M 10 X 75 Z.BIANCA	SCREW PARTIAL THREAD DIN 931 PG CL 8.8 M 10 X 75 Z. WHITE	VIS PARTIELLEMENT FILETÉE DIN 931 PG CL 8.8 M 10 X 75 Z. BLANC	TEILGEWINDESCHRAUBE DIN 931 PG CL 8.8 M 10 X 75 Z. WEIß	TORNILLO PARCIALMENTE ROSCADO PG DIN 931 CL 8.8 M 10 X 75 GALVANIZADO BLANCO
BV154	BV015400	NR	VITE TCEI PG DIN 912 CL 8.8 M 8 X 35	SCREW DIN 912 CL 8.8 M 8 X 35	VIS DIN 912 CL 8.8 M 8 X 35	SCHRAUBE DIN 912 CL 8.8 M 8 X 35	TORNILLO TCEI PG DIN 912 CL 8.8 M 8 X 35
BV155	BV015500	NR	VITE TCEI PG DIN 912 CL 8.8 M 5 X 20 GEOMET 321A	SCREW DIN 912 CL 8.8 M 5 X 20 GEOMET 321A	VIS DIN 912 CL 8.8 M 5 X 20 GEOMET 321A	SCHRAUBE DIN 912 CL 8.8 M 5 X 20 GEOMET 321A	TORNILLO TCEI PG DIN 912 CL 8.8 M 5 X 20 GEOMET 321A
BV156	BV015600	NR	VITE TBEI PG ISO 7380 CL 10.9 M 6 X 25 Z.BIANCA	HEX SOCKET SCREW ISO 7380 PG CL 10.9 M 6 X 25 Z. WHITE	VIS ISO 7380 PG CL 10.9 M 6 X 25 Z. BLANC	SCHRAUBE ISO 7380 PG CL 10.9 M 6 X 25 Z. WEIß	TORNILLO TBEI PG ISO 7380 CL 10.9 M 6 X 25 GALVANIZADO BLANCO
BV157	BV015700	NR	VITE TBEI PG ISO 7380 CL 10.9 M 8 X 20 Z.BIANCA	HEX SOCKET SCREW ISO 7380 PG CL 10.9 M 8 X 20 Z. WHITE	VIS ISO 7380 PG CL 10.9 M 8 X 20 Z. BLANC	TBEI PG SCHRAUBE ISO 7380 CL 10.9 M 8 X 20 Z. WEIß	TORNILLO TBEI PG ISO 7380 CL 10.9 M 8 X 20 GALVANIZADO BLANCO
BV158	BV015800	NR	VITE TBEI PG ISO 7380 CL 10.9 M 6 X 70 Z.BIANCA	HEX SOCKET SCREW ISO 7380 PG CL 10.9 M 6 X 70 Z. WHITE	VIS ISO 7380 PG CL 10.9 M 6 X 70 Z. BLANC	TBEI PG SCHRAUBE ISO 7380 PG CL 10.9 M 6 X 70 Z. WEIß	TORNILLO TBEI PG ISO 7380 CL 10.9 M 6 X 70 GALVANIZADO BLANCO





POS	Codice	U.M.	 Descrizione	 Description	 Designation	 Benennung	 Descripción
BV159	BV015900	NR	VITE TBEI PG ISO 7380 CL 10.9 M 10 X 20 Z.BIANCA	HEX SOCKET SCREW ISO 7380 PG CL 10.9 M 10 X 20 Z. WHITE	VIS SO 7380 PG CL 10.9 M 10 X 20 Z. BLANC	TBEI PG SCHRAUBE ISO 7380 PG CL 10.9 M 10 X 20 Z. WEIß	TORNILLO TBEI PG ISO 7380 CL 10.9 M 10 X 20 GALVANIZADO BLANCO
BV160	BV016000	NR	VITE TSPEI PG DIN 7991 CL 10.9 M 4 X 16 Z.BIANCA	TSPEI PG SCREW DIN 7991 CL 10.9 M4 X 16 Z. WHITE	VIS DIN 7991 CL 10.9 M4 X 16 Z. WHITE	TSPEI PG SCHRAUBE DIN 7991 CL 10.9 M4 X 16 Z. WEIß	TORNILLO TSPEI PG DIN 7991 CL 10.9 M 4 X 16 GALVANIZADO BLANCO
BV162	BV016200	NR	VITE TCEI PG DIN 912 CL 12.9 M14 X 45 GEOMET 321A	SCREW DIN 912 CL 12.9 M14 X 45 GEOMET 321A	VIS TCEI PG DIN 912 CL 12.9 M14 X 45 GEOMET 321A	SCHRAUBE TCEI PG DIN 912 CL 12.9 M14 X 45 GEOMET 321A	TORNILLO TCEI PG DIN 912 CL 12.9 M14 X 45 GEOMET 321A
BV163	BV016300	NR	VITE TCEI PG DIN 912 CL 8.8 M6 X 35	SCREW DIN 912 CL 8.8 M6 X 35	VIS DIN 912 CL 8.8 M6 X 35	SCHRAUBE DIN 912 CL 8.8 M6 X 35	TORNILLO DIN 912 CL 8.8 M6 X 35
BV164	BV016400	NR	VITE TCEI PG DIN 912 CL 8.8 M10 X 35	SCREW DIN 912 CL 8.8 M10 X 35	VIS DIN 912 CL 8.8 M10 X 35	SCHRAUBE DIN 912 CL 8.8 M10 X 35	TORNILLO DIN 912 CL 8.8 M10 X 35
BV165	BV016500	NR	VITE TE TUTTO FILETTO PG DIN 933 CL 8.8 M8 X 12 Z.BIANCA	SCREW ALL THREAD DIN 933 PG CL 8.8 M8 X 12 Z. WHITE	VIS ENTIÈREMENT FILETÉE DIN 933 PG CL 8.8 M8 X 12 Z. BLANC	VOLLGEWINDESCHRAUBE DIN 933 PG CL 8.8 M8 X 12 Z. WEIß	TORNILLO TOTALMENTE ROSCADO PG DIN 933 CL 8.8 M8 X 12 GALVANIZADO BLANCO
BV166	BV016600	NR	VITE TCEI PG DIN 912 CL 8.8 M4 X 20 Z. BIANCA	SCREW DIN 912 CL 8.8 M4 X 20 Z. WITHE	VIS DIN 912 CL 8.8 M4 X 20	SCHRAUBE DIN 912 CL 8.8 M4 X 20	TORNILLO TCEI PG DIN 912 CL 8.8 M4 X 20
BV167	BV016700	NR	VITE TCEI PG DIN 912 CL 8.8 M4 X 20 GEOMET 321A	ALL PF THREAD HEX HEAD SCREW DIN 961 CL 8.8 M 12 X 1,25 X 30 Z.BIANCA	VIS ENTIÈREMENT FILETÉE DIN 961 CL 8.8 M 12 X 1,25 X 30 Z.BLANC	VOLLGEWINDESCHRAUBE DIN 961 CL 8.8 M 12 X 1,25 X 30 Z. WEIß	TORNILLO TOTALMENTE ROSCADO TCEI PG DIN 912 CL 8.8 M4 X 20 GEOMET 321A
BV168	BV016800	NR	VITE TE TUTTO FILETTO PF DIN 961 CL 8.8 M 10 X 1,25 X 30 Z.BIANCA	ALL PF THREAD HEX HEAD SCREW DIN 961 CL 8.8 M 10 X 1,25 X 30 Z.BIANCA	VIS ENTIÈREMENT FILETÉE DIN 961 CL 8.8 M 10 X 1,25 X 30 Z.BLANC	VOLLGEWINDESCHRAUBE DIN 961 CL 8.8 M 10 X 1,25 X 30 Z. WEIß	TORNILLO TOTALMENTE ROSCADO PF DIN 961 CL 8.8 M 10 X 1,25 X 30 GALVANIZADO BLANCO
BV169	BV016900	NR	VITE TCEI PG DIN 912 CL 8.8 M 10 X 1,25 X 30 ZINCATA BIANCA	SCREW DIN 912 CL 8.8 M10 X 1,25 X 30	VIS DIN 912 CL 8.8 M10 X 1,25 X 30	SCHRAUBE DIN 912 CL 8.8 M10 X 1,25 X 30	TORNILLO TCEI PG DIN 912 CL 8.8 M 10 X 1,25 X 30
BV170	BV017000	NR	VITE TE PARZIALE FILETTO PF DIN 960 CL 8.8 M 10 X 1,25 X 60 Z.BIANCA	PARTIAL PF THREAD HEX HEAD SCREW DIN 960 CL 8.8 M 10 X 1,25 X 60 Z.BIANCA	VIS FILETÉE DIN 960 CL 8.8 M 10 X 1,25 X 60 Z.BLANC	VOLLGEWINDESCHRAUBE DIN 960 CL 8.8 M 10 X 1,25 X 60 Z. WEIß	TORNILLO ROSCADO DIN 960 CL 8.8 M 10 X 1,25 X 30 GALVANIZADO BLANCO
BV171	BV017100	NR	VITE TE TUTTO FILETTO PF DIN 961 CL 10.9 M 12 X 1,25 X 25 Z.BIANCA	ALL PF THREAD HEX HEAD SCREW DIN 961 CL 10.9 M 12 X 1,25 X 25 Z.BIANCA	VIS ENTIÈREMENT FILETÉE DIN 961 CL 10.9 M 12 X 1,25 X 25 Z.BLANC	VOLLGEWINDESCHRAUBE DIN 961 CL 10.9 M 12 X 1,25 X 25 Z. WEIß	TORNILLO TOTALMENTE ROSCADO DIN 961 CL 10.9 M 12 X 1,25 X 25 GALVANIZADO BLANCO





POS	Codice	U.M.	 Descrizione	 Description	 Designation	 Benennung	 Descripción
BV172	BV017200	NR	VITE TCEI UNC ASME/ANSI B18.3 ASTM A 574 5/8 X 11/2 GEO 321A	VITE TCEI UNC ASME/ANSI B18.3 ASTM A 574 5/8 X 11/2 GEO 321A	VIS TCEI UNC ASME/ANSI B18.3 ASTM A 574 5/8 X 11/2 GEO 321A	SCHRAUBE TCEI UNC ASME/ANSI B18.3 ASTM A 574 5/8 X 11/2 GEO 321A	TORNILLO TCEI UNC ASME/ANSI B18.3 ASTM A 574 5/8 X 11/2 GEO 321A
BV173	BV017300	NR	VITE TE TUTTO FILETTO PG DIN 933 CL 8.8 M12 X 30 Z.BIANCA	SCREW ALL THREAD DIN 933 PG CL 8.8 M12 X 30 Z. WHITE	VIS ENTIÈREMENT FILETÉE DIN 933 PG CL 8.8 M12 X 30 Z. BLANC	VOLLGEWINDESCHRAUBE DIN 933 PG CL 8.8 M12 X 30 Z. WEIß	TORNILLO TOTALMENTE ROSCADO DIN 933 CL 8.8 M12 X 30 GALVANIZADO BLANCO
BV174	BV017400	NR	VITE TE TUTTO FILETTO PG DIN 933 CL 8.8 M5 X 45 Z.BIANCA	SCREW ALL THREAD DIN 933 PG CL 8.8 M5 X 45 Z. WHITE	VIS ENTIÈREMENT FILETÉE DIN 933 PG CL 8.8 M5 X 45 Z. BLANC	VOLLGEWINDESCHRAUBE DIN 933 PG CL 8.8 M5 X 45 Z. WEIß	TORNILLO TOTALMENTE ROSCADO DIN 933 CL 8.8 M5 X 45 GALVANIZADO BLANCO
BV175	BV017500	NR	VITE TE PARZIALE FILETTO PG DIN 931 CL 8.8 M 12 X 80 Z.BIANCA	SCREW PARTIAL THREAD DIN 931 PG CL 8.8 M12 X 80 Z. WHITE	VIS FILETÉE DIN 931 PG CL 8.8 M12 X 80 Z. BLANC	VOLLGEWINDESCHRAUBE DIN 931 PG CL 8.8 M12 X 80 Z. WEIßE	VIS ROSCADO DIN 931 CL 8.8 M12 X 80 GALVANIZADO BLANCO
BV176	BV017600	NR	VITE TCEI PG DIN 912 CL 8.8 M 6 X 25 Z.BIANCA	SCREW DIN 912 CL 8.8 M6 X 25	VIS DIN 912 CL 8.8 M6 X 25	SCHRAUBE DIN 912 CL 8.8 M6 X 25	TORNILLO TCEI PG DIN 912 CL 8.8 M6 X 25
BV177	BV017700	NR	VITE TE PARZIALE FILETTO PG DIN 931 CL 8.8 M 12 X 85 Z.BIANCA	SCREW PARTIAL THREAD DIN 931 PG CL 8.8 M12 X 85 Z. WHITE	VIS FILETÉE DIN 931 PG CL 8.8 M12 X 85 Z. BLANC	VOLLGEWINDESCHRAUBE DIN 931 PG CL 8.8 M12 X 85 Z. WEIßE	TORNILLO ROSCADO DIN 931 CL 8.8 M12 X 85 GALVANIZADO BLANCO
BV178	BV017800	NR	VITE TE TUTTO FILETTO PG DIN 933 CL 8.8 M8 X 90 Z.BIANCA	SCREW ALL THREAD DIN 933 PG CL 8.8 M8 X 90 Z. WHITE	VIS ENTIÈREMENT FILETÉE DIN 933 PG CL 8.8 M8 X 90 Z. BLANC	VOLLGEWINDESCHRAUBE DIN 933 PG CL 8.8 M8 X 90 Z. WEIßE	TORNILLO TOTALMENTE ROSCADO DIN 933 CL 8.8 M8 X 90 GALVANIZADO BLANCO
BV179	BV017900	NR	VITE TE TUTTO FILETTO PG DIN 933 CL 8.8 M5 X 40 Z.BIANCA	SCREW ALL THREAD DIN 933 PG CL 8.8 M5 X 40 Z. WHITE	VIS ENTIÈREMENT FILETÉE DIN 933 PG CL 8.8 M5 X 40 Z. BLANC	VOLLGEWINDESCHRAUBE DIN 933 PG CL 8.8 M5 X 40 Z. WEIßE	TORNILLO TOTALMENTE ROSCADO PG DIN 933 CL 8.8 M5 X 40 GALVANIZADO BLANCO
BV180	BV018000	NR	VITE TE TUTTO FILETTO PG DIN 933 CL 8.8 M6 X 75 Z.BIANCA	SCREW ALL THREAD DIN 933 PG CL 8.8 M6 X 75 Z. WHITE	VIS ENTIÈREMENT FILETÉE DIN 933 PG CL 8.8 M6 X 75 Z. BLANC	VOLLGEWINDESCHRAUBE DIN 933 PG CL 8.8 M6 X 75 Z. WEIß	TORNILLO TOTALMENTE ROSCADO DIN 933 CL 8.8 M6 X 75 GALVANIZADO BLANCO
BV182	BV018200	NR	VITE TE TUTTO FILETTO PG DIN 933 CL 10.9 M 16 X 70 Z.BIANCA	SCREW ALL THREAD DIN 933 PG CL 10.9 M 16 X 70 Z. WHITE	VIS ENTIÈREMENT FILETÉE DIN 933 CL 10.9 M 16 X 70 GALVANISÉE BLANCHE	VOLLGEWINDESCHRAUBE DIN 933 PG CL 10.9 M 16 X 70 Z. WEIß	TORNILLO TOTALMENTE FILETADO DIN 933 CL 10.9 M 16 X 70 TOTALMENTE ROSCADO
BV183	BV018300	NR	VITE TE TUTTO FILETTO PG DIN 933 CL 8.8 M5 X 10 Z.BIANCA	SCREW ALL THREAD DIN 933 PG CL 8.8 M5 X 10 Z. WHITE	VIS ENTIÈREMENT FILETÉE DIN 933 PG CL 8.8 M5 X 10 Z. BLANC	VOLLGEWINDESCHRAUBE DIN 933 PG CL 8.8 M5 X 10 Z. WEIß	TORNILLO TOTALMENTE ROSCADO DIN 933 CL 8.8 M5 X 10 GALVANIZADO BLANCO

POS	Codice	U.M.	 Descrizione	 Description	 Designation	 Benennung	 Descripción
BV184	BV018400	NR	VITE TE TUTTO FILETTO PG DIN 933 CL 8.8 M10 X 16 Z.BIANCA	SCREW ALL THREAD DIN 933 PG CL 8.8 M10 X 16 Z. WHITE	VIS ENTIÈREMENT FILETÉE DIN 933 PG CL 8.8 M10 X 16 Z. BLANC	VOLLGEWINDESCHRAUBE DIN 933 PG CL 8.8 M10 X 16 Z. WEIß	TORNILLO TOTALMENTE ROSCADO DIN 933 CL 8.8 M10 X 16 GALVANIZADO BLANCO
BV185	BV018500	NR	VITE TCEI PG DIN 912 CL 8.8 M 8 X 55 Z.BIANCA	SCREW DIN 912 CL 8.8 M8 X 55	VIS DIN 912 CL 8.8 M8 X 55	SCHRAUBE DIN 912 CL 8.8 M8 X 55	TORNILLO DIN 912 CL 8.8 M8 X 55
BV186	BV018600	NR	VITE TCEI PG DIN 912 CL 12.9 M10 X 30 GEOMET 321A	SCREW DIN 912 CL 12.9 M10 X 30 GEOMET 321A	VIS DIN 912 CL 12.9 M10 X 30 GEOMET 321A	SCHRAUBE DIN 912 CL 12.9 M10 X 30 GEOMET 321A	TORNILLO DIN 912 CL 12.9 M10 X 30 GEOMET 321A
BV187	BV018700	NR	VITE TCEI PG DIN 912 CL 12.9 M14 X 40 GEOMET 321A	SCREW DIN 912 CL 12.9 M14 X 40 GEOMET 321A	VIS TCEI PG DIN 912 CL 12.9 M14 X 40 GEOMET 321A	SCHRAUBE DIN 912 CL 12.9 M14 X 40 GEOMET 321A	TORNILLO DIN 912 CL 12.9 M14 X 40 GEOMET 321A
BV188	BV018800	NR	VITE TE TUTTO FILETTO PG DIN 933 CL 8.8 M 12 X 60 Z.BIANCA	SCREW ALL THREAD DIN 933 PG CL 8.8 M12 X 60 Z. WHITE	VIS ENTIÈREMENT FILETÉE DIN 933 PG CL 8.8 M12 X 60 Z. BLANC	VOLLGEWINDESCHRAUBE DIN 933 PG CL 8.8 M12 X 60 Z. WEIßE	VIS TOTALMENTE ROSCADO DIN 933 CL 8.8 M12 X 60 GALVANIZADO BLANCO
BV189	BV018900	NR	VITE TE TUTTO FILETTO PG DIN 933 CL 8.8 M 12 X 55 Z.BIANCA	SCREW ALL THREAD DIN 933 PG CL 8.8 M12 X 55 Z. WHITE	VIS ENTIÈREMENT FILETÉE DIN 933 PG CL 8.8 M12 X 55 Z. BLANC	VOLLGEWINDESCHRAUBE DIN 933 PG CL 8.8 M12 X 55 Z. WEIßE	VIS TOTALMENTE ROSCADO DIN 933 CL 8.8 M12 X 55 GALVANIZADO BLANCO
BV190	BV019000	NR	VITE TE TUTTO FILETTO PG DIN 933 CL 8.8 M 12 X 50 Z.BIANCA	SCREW ALL THREAD DIN 933 PG CL 8.8 M12 X 50 Z. WHITE	VIS ENTIÈREMENT FILETÉE DIN 933 PG CL 8.8 M12 X 50 Z. BLANC	VOLLGEWINDESCHRAUBE DIN 933 PG CL 8.8 M12 X 50 Z. WEIßE	VIS TOTALMENTE ROSCADO DIN 933 CL 8.8 M12 X 50 GALVANIZADO BLANCO
BV191	BV019100	NR	VITE TE TUTTO FILETTO PG DIN 933 CL 8.8 M 16 X 50 Z.BIANCA	SCREW ALL THREAD DIN 933 PG CL 8.8 M16 X 50 Z. WHITE	VIS ENTIÈREMENT FILETÉE DIN 933 PG CL 8.8 M16 X 50 Z. BLANC	VOLLGEWINDESCHRAUBE DIN 933 PG CL 8.8 M16 X 50 Z. WEIßE	VIS TOTALMENTE ROSCADO DIN 933 CL 8.8 M16 X 50 GALVANIZADO BLANCO
BV192	BV019200	NR	VITE TE TUTTO FILETTO PG DIN 933 CL 8.8 M 16 X 55 Z.BIANCA	SCREW ALL THREAD DIN 933 PG CL 8.8 M16 X 55 Z. WHITE	VIS ENTIÈREMENT FILETÉE DIN 933 PG CL 8.8 M16 X 55 Z. BLANC	VOLLGEWINDESCHRAUBE DIN 933 PG CL 8.8 M16 X 55 Z. WEIßE	VIS TOTALMENTE ROSCADO DIN 933 CL 8.8 M16 X 55 GALVANIZADO BLANCO
BV193	BV019300	NR	VITE TE PARZIALE FILETTO PG DIN 931 CL 8.8 M 10 X 55 Z.BIANCA	SCREW PARTIAL THREAD DIN 931 PG CL 8.8 M 10 X 55 Z. WHITE	VIS PARTIELLEMENT FILETÉE DIN 931 PG CL 8.8 M 10 X 55 Z. BLANC	TEILGEWINDESCHRAUBE DIN 931 PG CL 8.8 M 10 X 55 Z. WEIß	TORNILLO PARCIALMENTE ROSCADO PG DIN 931 CL 8.8 M 10 X 55 GALVANIZADO BLANCO
BV194	BV019400	NR	VITE TE PARZIALE FILETTO PG DIN 931 CL 8.8 M 16 X 230 Z.BIANCA	SCREW PARTIAL THREAD DIN 931 PG CL 8.8 M 16 X 230 Z. WHITE	VIS PARTIELLEMENT FILETÉE DIN 931 PG CL 8.8 M 16 X 230 Z. BLANC	TEILGEWINDESCHRAUBE DIN 931 PG CL 8.8 M 16 X 230 Z. WEIß	TORNILLO PARCIALMENTE ROSCADO PG DIN 931 CL 8.8 M 16 X 230 GALVANIZADO BLANCO





POS	Codice	U.M.	 Descrizione	 Description	 Designation	 Benennung	 Descripción
BV195	BV019500	NR	VITE TE PARZIALE FILETTO PG DIN 931 CL 8.8 M 6 X 50 Z.BIANCA	SCREW PARTIAL THREAD DIN 931 PG CL 8.8 M 6 X 50 Z. WHITE	VIS PARTIELLEMENT FILETÉE DIN 931 PG CL 8.8 M 6 X 50 Z. BLANC	TEILGEWINDESCHRAUBE DIN 931 PG CL 8.8 M 6 X 50 Z. WEIß	TORNILLO PARCIALMENTE ROSCADO PG DIN 931 CL 8.8 M 6 X 50 GALVANIZADO BLANCO
BV196	BV019600	NR	VITE TE PARZIALE FILETTO PG DIN 931 CL 8.8 M 6 X 65 Z.BIANCA	SCREW PARTIAL THREAD DIN 931 PG CL 8.8 M 6 X 65 Z. WHITE	VIS PARTIELLEMENT FILETÉE DIN 931 PG CL 8.8 M 6 X 65 Z. BLANC	TEILGEWINDESCHRAUBE DIN 931 PG CL 8.8 M 6 X 65 Z. WEIß	TORNILLO PARCIALMENTE ROSCADO PG DIN 931 CL 8.8 M 6 X 65 GALVANIZADO BLANCO
BV197	BV019700	NR	VITE TE PARZIALE FILETTO PG DIN 931 CL 8.8 M 8 X 45 Z.BIANCA	SCREW PARTIAL THREAD DIN 931 PG CL 8.8 M 8 X 45 Z. WHITE	VIS PARTIELLEMENT FILETÉE DIN 931 PG CL 8.8 M 8 X 45 Z. BLANC	TEILGEWINDESCHRAUBE DIN 931 PG CL 8.8 M 8 X 45 Z. WEIß	TORNILLO PARCIALMENTE ROSCADO PG DIN 931 CL 8.8 M 8 X 45 GALVANIZADO BLANCO
BV198	BV019800	NR	VITE TE PARZIALE FILETTO PG DIN 931 CL 8.8 M 8 X 55 Z.BIANCA	SCREW PARTIAL THREAD DIN 931 PG CL 8.8 M 8 X 55 Z. WHITE	VIS PARTIELLEMENT FILETÉE DIN 931 PG CL 8.8 M 8 X 55 Z. BLANC	TEILGEWINDESCHRAUBE DIN 931 PG CL 8.8 M 8 X 55 Z. WEIß	TORNILLO PARCIALMENTE ROSCADO PG DIN 931 CL 8.8 M 8 X 55 GALVANIZADO BLANCO
BV199	BV019900	NR	VITE TE PARZIALE FILETTO PG DIN 931 CL 8.8 M 8 X 60 Z.BIANCA	SCREW PARTIAL THREAD DIN 931 PG CL 8.8 M 8 X 60 Z. WHITE	VIS PARTIELLEMENT FILETÉE DIN 931 PG CL 8.8 M 8 X 60 Z. BLANC	TEILGEWINDESCHRAUBE DIN 931 PG CL 8.8 M 8 X 60 Z. WEIß	TORNILLO PARCIALMENTE ROSCADO PG DIN 931 CL 8.8 M 8 X 60 GALVANIZADO BLANCO
BV200	BV020000	NR	VITE TE TUTTO FILETTO PG DIN 933 CL 10.9 M 16 X 40	SCREW ALL THREAD DIN 933 PG CL 10.9 M 16 X 40	VIS ENTIÈREMENT FILETÉE DIN 933 CL 10.9 M 16 X 40	VOLLGEWINDESCHRAUBE DIN 933 PG CL 10.9 M 16 X 40	TORNILLO TOTALMENTE FILETADO DIN 933 CL 10.9 M 16 X 40
BV201	BV020100	NR	VITE TSPEI PG DIN 7991 CL 10.9 M16 X 45 Z.BIANCA	TSPEI PG SCREW DIN 7991 CL 10.9 M16 X 45 Z. WHITE	VIS DIN 7991 CL 10.9 M16 X 45 Z. WHITE	TSPEI PG SCHRAUBE DIN 7991 CL 10.9 M16 X 45 Z. WEIß	TORNILLO TSPEI PG DIN 7991 CL 10.9 M 16 X 45 GALVANIZADO BLANCO
BV202	BV020200	NR	VITE TCEI PG DIN 912 CL 12.9 M3 X 12 ZINC. IRIDESCENTE FE/ZN5IVS	SCREW DIN 912 CL 12.9 M3 X 12 ZINC. IRIDESCENTE FE/ZN5IVS	VIS DIN 912 CL 12.9 M3 X 12 ZINC. IRIDESCENTE FE/ZN5IVS	SCHRAUBE DIN 912 CL 12.9 M3 X 12 ZINC. IRIDESCENTE FE/ZN5IVS	TORNILLO DIN 912 CL 12.9 M3 X 12 ZINC. IRIDESCENTE FE/ZN5IVS
BV203	BV020300	NR	VITE TC CROCE PG DIN 7985 CL 4.8 M M 3 X 5 Z.BIANCA	SCREW DIN 7985 CL 4.8 M M 3 X 5	VIS CROIX DIN 7985 CL 4.8 M M 3 X 5 GALVANISATION BLANCHE	SCHRAUBE	TORNILLO
BV204	BV020400	NR	VITE TC CROCE PG DIN 7985 CL 4.8 M M 3 X 8 Z.BIANCA	SCREW DIN 7985 CL 4.8 M M 3 X 8	VIS CROIX DIN 7985 CL 4.8 M M 3 X 8 GALVANISATION BLANCHE	SCHRAUBE	TORNILLO
BV205	BV020500	NR	VITE TTQST DIN 603 CL 4.8 M 8 X 35 Z.BIANCA	TTQST SCREW DIN 603 CL 4.8 M 8 X 35 Z. WHITE			

POS	Codice	U.M.	 Descrizione	 Description	 Designation	 Benennung	 Descripción
BV206	BV020600	NR	VITE TC CROCE PG DIN 7985 CL 4.8 M M 5 X 80 Z.BIANCA	SCREW DIN 7985 CL 4.8 M M 5 X 80	VIS CROIX DIN 7985 CL 4.8 M M 5 X 80 GALVANISATION BLANCHE	SCHRAUBE	TORNILLO
BV207	BV020700	NR	VITE TE PARZIALE FILETTO PG DIN 931 CL 8.8 M 10 X 80 Z.BIANCA	SCREW PARTIAL THREAD DIN 931 PG CL 8.8 M 10 X 80 Z. WHITE	VIS PARTIELLEMENT FILETÉE DIN 931 PG CL 8.8 M 10 X 80 Z. BLANC	TEILGEWINDESCHRAUBE DIN 931 PG CL 8.8 M 10 X 80 Z. WEIß	TORNILLO PARCIALMENTE ROSCADO PG DIN 931 CL 8.8 M 10 X 80 GALVANIZADO BLANCO
BV208	BV020800	NR	VITE TE TUTTO FILETTO PG DIN 933 CL 8.8 M 16 X 35 Z.D.BIANCA	SCREW ALL THREAD DIN 933 PG CL 8.8 M 16 X 35 ZD WHITE	VIS ENTIÈREMENT FILETÉE DIN 933 CL 8.8 M 16 X 35 GALVANISATION BLANCHE	SCHRAUBE	TORNILLO
BV209	BV020900	NR	VITE TE PARZIALE FILETTO PG DIN 931 CL 8.8 M 10 X 95 Z.BIANCA	SCREW PARTIAL THREAD DIN 931 PG CL 8.8 M 10 X 95 Z. WHITE	VIS PARTIELLEMENT FILETÉE DIN 931 PG CL 8.8 M 10 X 95 Z. BLANC	TEILGEWINDESCHRAUBE DIN 931 PG CL 8.8 M 10 X 95 Z. WEIß	TORNILLO PARCIALMENTE ROSCADO PG DIN 931 CL 8.8 M 10 X 95 GALVANIZADO BLANCO
BV210	BV021000	NR	VITE TE TUTTO FILETTO PG DIN 933 CL 8.8 M 6 X 14 Z.D.BIANCA	SCREW ALL THREAD DIN 933 PG CL 8.8 M 6 X 14 ZD WHITE	VIS ENTIÈREMENT FILETÉE DIN 933 CL 8.8 M 6 X 14 GALVANISATION BLANCHE	SCHRAUBE	TORNILLO
BV211	BV021100	NR	VITE TE TUTTO FILETTO PG DIN 933 CL 8.8 M 12 X 25 Z.D.BIANCA	SCREW ALL THREAD DIN 933 PG CL 8.8 M 12 X 25 ZD WHITE	VIS ENTIÈREMENT FILETÉE DIN 933 CL 8.8 M 12 X 25 GALVANISATION BLANCHE	SCHRAUBE	TORNILLO
BV212	BV021200	NR	VITE TE TUTTO FILETTO PG DIN 933 CL 8.8 M 4 X 14 Z.D.BIANCA	SCREW ALL THREAD DIN 933 PG CL 8.8 M 4 X 14 ZD WHITE	VIS ENTIÈREMENT FILETÉE DIN 933 CL 8.8 M 4 X 14 GALVANISATION BLANCHE	SCHRAUBE	TORNILLO
BV213	BV021300	NR	VITE TE TUTTO FILETTO PG DIN 933 CL 10.9 M 16 X 60	SCREW ALL THREAD DIN 933 PG CL 10.9 M 16 X 60	VIS ENTIÈREMENT FILETÉE DIN 933 CL 10.9 M 16 X 60	SCHRAUBE	TORNILLO
BV214	BV021400	NR	VITE TE PARZIALE FILETTO PG DIN 931 CL 8.8 M 6 X 100 Z.BIANCA	SCREW PARTIAL THREAD DIN 931 PG CL 8.8 M 6 X 100 Z. WHITE	VIS PARTIELLEMENT FILETÉE DIN 931 PG CL 8.8 M 6 X 100 Z. BLANC	TEILGEWINDESCHRAUBE DIN 931 PG CL 8.8 M 6 X 100 Z. WEIß	TORNILLO PARCIALMENTE ROSCADO PG DIN 931 CL 8.8 M 6 X 100 GALVANIZADO BLANCO
BV215	BV021500	NR	VITE TE PARZIALE FILETTO PG DIN 931 CL 10.9 M 16 X 110	SCREW PARTIAL THREAD DIN 931 PG CL 10.9 M 16 X 110	VIS PARTIELLEMENT FILETÉE DIN 931 CL 10.9 M 16 X 110	SCHRAUBE	TORNILLO
BV216	BV021600	NR	VITE TE PARZIALE FILETTO PG DIN 931 CL 10.9 M 16 X 240 Z.D.BIANCA	SCREW PARTIAL THREAD DIN 931 PG CL 10.9 M 16 X 240 ZD WHITE	VIS PARTIELLEMENT FILETÉE DIN 931 CL 10.9 M 16 X 240 GALVANISATION BLANCHE	SCHRAUBE	TORNILLO

POS	Codice	U.M.	 Descrizione	 Description	 Designation	 Benennung	 Descripción
BV217	BV021700	NR	VITE TSPEI PG DIN 7991 CL 10.9 M 8 X 30 Z.BIANCA	TSPEI PG SCREW DIN 7991 CL 10.9 M8 X 30 Z. WHITE	VIS TSPEI PG DIN 7991 CL 10.9 M 8 X 30 GALVANISATION BLANCHE	SCHRAUBE	TORNILLO
BV218	BV021800	NR	VITE TSPEI PG DIN 7991 CL 10.9 M 5 X 6 Z.BIANCA	TSPEI PG SCREW DIN 7991 CL 10.9 M5 X 6 Z. WHITE	VIS TSPEI PG DIN 7991 CL 10.9 M 5 X 6 GALVANISATION BLANCHE	SCHRAUBE	TORNILLO
BV219	BV021900	NR	VITE TSPEI PG DIN 7991 CL 10.9 M 5 X 70 Z.BIANCA	TSPEI PG SCREW DIN 7991 CL 10.9 M5 X 70 Z. WHITE	VIS TSPEI PG DIN 7991 CL 10.9 M 5 X 70 GALVANISATION BLANCHE	SCHRAUBE	TORNILLO
BV220	BV022000	NR	VITE TSPEI PG DIN 7991 CL 10.9 M 12 X 35 Z.BIANCA	TSPEI PG SCREW DIN 7991 CL 10.9 M12 X 35 Z. WHITE	VIS TSPEI PG DIN 7991 CL 10.9 M 12 X 35 GALVANISATION BLANCHE	SCHRAUBE	TORNILLO
BV221	BV022100	NR	VITE TCEI PG DIN 912 CL 12.9 M10 X 20 GEOMET 321A	SCREW DIN 912 CL 12.9 M10 X 20 GEOMET 321A	VIS DIN 912 CL 12.9 M10 X 20 GEOMET 321A	SCHRAUBE DIN 912 CL 12.9 M10 X 20 GEOMET 321A	TORNILLO DIN 912 CL 12.9 M10 X 20 GEOMET 321A
BV222	BV022200	NR	VITE TCEI PG DIN 912 CL 12.9 M8 X 90 GEOMET 321A	SCREW DIN 912 CL 12.9 M8 X 90 GEOMET 321A	VIS DIN 912 CL 12.9 M8 X 90 GEOMET 321A	SCHRAUBE DIN 912 CL 12.9 M8 X 90 GEOMET 321A	TORNILLO DIN 912 CL 12.9 M8 X 90 GEOMET 321A
BV223	BV022300	NR	VITE TCEI PG DIN 912 CL 12.9 M3 X 5 ZINC.	SCREW DIN 912 CL 12.9 M3 X 5 ZINC.	VIS DIN 912 CL 12.9 M3 X 5 ZINC.	SCHRAUBE DIN 912 CL 12.9 M3 X 5 ZINC.	TORNILLO DIN 912 CL 12.9 M3 X 5 ZINC.
BV224	BV022400	NR	VITE TBEI PG ISO 7380 CL 10.9 M 8 X 22 Z.BIANCA	HEX SOCKET SCREW ISO 7380 PG CL 10.9 M 8 X 22 Z. WHITE	VIS ISO 7380 PG CL 10.9 M 8 X 22 Z. BLANC	SCHRAUBE ISO 7380 PG CL 10.9 M 8 X 22 Z. WEIß	TORNILLO TBEI PG ISO 7380 CL 10.9 M 8 X 22 GALVANIZADO BLANCO
BV225	BV022500	NR	VITE TE PARZIALE FILETTO PG DIN 931 CL 8.8 M 10 X 100 Z.BIANCA	SCREW PARTIAL THREAD DIN 931 PG CL 8.8 M 10 X 100 Z. WHITE	VIS PARTIELLEMENT FILETÉE DIN 931 PG CL 8.8 M 10 X 100 Z. BLANC	TEILGEWINDESCHRAUBE DIN 931 PG CL 8.8 M 10 X 100 Z. WEIß	TORNILLO PARCIALMENTE ROSCADO PG DIN 931 CL 8.8 M 10 X 100 GALVANIZADO BLANCO
BV226	BV022600	NR	VITE TE PARZIALE FILETTO PG DIN 931 CL 8.8 M 10 X 110 Z.BIANCA	SCREW PARTIAL THREAD DIN 931 PG CL 8.8 M 10 X 110 Z. WHITE	VIS PARTIELLEMENT FILETÉE DIN 931 PG CL 8.8 M 10 X 110 Z. BLANC	TEILGEWINDESCHRAUBE DIN 931 PG CL 8.8 M 10 X 110 Z. WEIß	TORNILLO PARCIALMENTE ROSCADO PG DIN 931 CL 8.8 M 10 X 110 GALVANIZADO BLANCO
BV227	BV022700	NR	VITE TE PARZIALE FILETTO PG DIN 931 CL 10.9 M 12 X 45 Z.D.BIANCA	SCREW PARTIAL THREAD DIN 931 PG CL 10.9 M 12 X 45 ZD WHITE	VIS PARTIEL FILETÉE DIN 931 CL 10.9 M 12 X 45 GALVANISATION BLANCHE	SCHRAUBE	TORNILLO

POS	Codice	U.M.	 Descrizione	 Description	 Designation	 Benennung	 Descripción
BV228	BV022800	NR	VITE TE TUTTO FILETTO PG DIN 933 CL 10.9 M 14 X 35 Z.D.BIANCA	SCREW ALL THREAD DIN 933 PG CL 10.9 M 14 X 35 ZD WHITE	VIS ENTIÈREMENT FILETÉE DIN 933 CL 10.9 M 14 X 35 GALVANISATION BLANCHE	SCHRAUBE	TORNILLO
BV229	BV022900	NR	VITE TSPEI PG DIN 7991 CL 10.9 M 12 X 30 Z.BIANCA	TSPEI PG SCREW DIN 7991 CL 10.9 M12 X 30 Z. WHITE	VIS TSPEI PG DIN 7991 CL 10.9 M 12 X 30 GALVANISATION BLANCHE	SCHRAUBE	TORNILLO
BV230	BV023000	NR	VITE TE FLANGIATA TUTTO FILETTO PG DIN 6921 CL 8.8 M 5 X 12 ZINCONICKEL NERO +SIGILLANTE	FLANGE SCREW ALL THREAD DIN 6921 PG CL 8.8 M 5 X 12 ZINCNICKEL BLACK +SEALANT	VIS	SCHRAUBE	TORNILLO
BV231	BV023100	NR	VITE TE FLANGIATA TUTTO FILETTO PG DIN 6921 CL 8.8 M 6 X 16 ZINCONICKEL NERO +SIGILLANTE	FLANGE SCREW ALL THREAD DIN 6921 PG CL 8.8 M 6 X 16 ZINCNICKEL BLACK +SEALANT	VIS	SCHRAUBE	TORNILLO
BV232	BV023200	NR	VITE TE TUTTO FILETTO PG DIN 933 CL 8.8 M 5 X 25 Z.D.BIANCA	SCREW ALL THREAD DIN 933 PG CL 8.8 M 5 X 25 ZD WHITE	VIS ENTIÈREMENT FILETÉE DIN 933 CL 8.8 M 5 X 25 GALVANISATION BLANCHE	SCHRAUBE	TORNILLO
BV233	BV023300	NR	VITE TE TUTTO FILETTO PG DIN 933 CL 8.8 M 8 X 130 Z.D.BIANCA	SCREW ALL THREAD DIN 933 PG CL 8.8 M 8 X 130 ZD WHITE	VIS ENTIÈREMENT FILETÉE DIN 933 CL 8.8 M 8 X 130 GALVANISATION BLANCHE	SCHRAUBE	TORNILLO
BV234	BV023400	NR	VITE TBEI PG ISO 7380 CL 10.9 M 10 X 30 Z.BIANCA	HEX SOCKET SCREW ISO 7380 PG CL 10.9 M 10 X 30 Z. WHITE	VIS ISO 7380 PG CL 10.9 M 10 X 30 Z. BLANC	SCHRAUBE ISO 7380 PG CL 10.9 M10 X 30 Z. WEIß	TORNILLO TBEI PG ISO 7380 CL 10.9 M 10 X 30 GALVANIZADO BLANCO
BV235	BV023500	NR	VITE TE TUTTO FILETTO PG DIN 933 CL 10.9 M 16 X 35 Z.D.BIANCA	SCREW ALL THREAD DIN 933 PG CL 10.9 M 16 X 35 ZD WHITE	VIS ENTIÈREMENT FILETÉE DIN 933 CL 10.9 M 16 X 35 GALVANISATION BLANCHE	SCHRAUBE	TORNILLO
BV236	BV023600	NR	VITE TE PARZIALE FILETTO PG DIN 931 CL 8.8 M 6 X 45 Z.BIANCA	SCREW PARTIAL THREAD DIN 931 PG CL 8.8 M 6 X 45 Z. WHITE	VIS PARTIELLEMENT FILETÉE DIN 931 PG CL 8.8 M 6 X 45 Z. BLANC	TEILGEWINDESCHRAUBE DIN 931 PG CL 8.8 M 6 X 45 Z. WEIß	TORNILLO PARCIALMENTE ROSCADO PG DIN 931 CL 8.8 M 6 X 45 GALVANIZADO BLANCO
BV237	BV023700	NR	VITE TE TUTTO FILETTO PG DIN 933 CL 10.9 M 12 X 30 Z.D.BIANCA	SCREW ALL THREAD DIN 933 PG CL 10.9 M 12 X 30 ZD WHITE	VIS ENTIÈREMENT FILETÉE DIN 933 CL 10.9 M 12 X 30 GALVANISATION BLANCHE	SCHRAUBE	TORNILLO





POS	Codice	U.M.	 Descrizione	 Description	 Designation	 Benennung	 Descripción
BV238	BV023800	NR	VITE TE PARZIALE FILETTO PG DIN 931 CL 8.8 M 16 X 90 Z.BIANCA	SCREW PARTIAL THREAD DIN 931 PG CL 8.8 M 16 X 90 Z. WHITE	VIS PARTIELLEMENT FILETÉE DIN 931 PG CL 8.8 M 16 X 90 Z. BLANC	TEILGEWINDESCHRAUBE DIN 931 PG CL 8.8 M 16 X 90 Z. WEIß	TORNILLO PARCIALMENTE ROSCADO PG DIN 931 CL 8.8 M 16 X 90 GALVANIZADO BLANCO
BV239	BV023900	NR	VITE TE PARZIALE FILETTO PG DIN 931 CL 8.8 M 12 X 65 Z.BIANCA	SCREW PARTIAL THREAD DIN 931 PG CL 8.8 M 12 X 65 Z. WHITE	VIS PARTIELLEMENT FILETÉE DIN 931 PG CL 8.8 M 12 X 65 Z. BLANC	TEILGEWINDESCHRAUBE DIN 931 PG CL 8.8 M 12 X 65 Z. WEIß	TORNILLO PARCIALMENTE ROSCADO PG DIN 931 CL 8.8 M 12 X 65 GALVANIZADO BLANCO
BV240	BV024000	NR	VITE TC CROCE PG DIN 7985 CL 4.8 M 5 X 20 Z.BIANCA	SCREW DIN 7985 CL 4.8 M 5 X 20	VIS CROIX DIN 7985 CL 4.8 M 5 X 20 GALVANISATION BLANCHE	SCHRAUBE	TORNILLO
BV241	BV024100	NR	VITE TSPEI PG DIN 7991 CL 10.9 M 10 X 35 Z.BIANCA	TSPEI PG SCREW DIN 7991 CL 10.9 M 10 X 35 Z. WHITE	VIS TSPEI PG DIN 7991 CL 10.9 M 10 X 35 GALVANISATION BLANCHE	SCHRAUBE	TORNILLO
BV242	BV024200	NR	VITE TSPEI PG DIN 7991 CL 10.9 M 6 X 12 Z.BIANCA	TSPEI PG SCREW DIN 7991 CL 10.9 M 6 X 12 Z. WHITE	VIS TSPEI PG DIN 7991 CL 10.9 M 6 X 12 GALVANISATION BLANCHE	SCHRAUBE	TORNILLO
BV243	BV024300	NR	VITE TE PARZIALE FILETTO PG DIN 931 CL 8.8 M 12 X 150 Z.BIANCA	SCREW PARTIAL THREAD DIN 931 PG CL 8.8 M 12 X 150 Z. WHITE	VIS PARTIELLEMENT FILETÉE DIN 931 PG CL 8.8 M 12 X 150 Z. BLANC	TEILGEWINDESCHRAUBE DIN 931 PG CL 8.8 M 12 X 150 Z. WEIß	TORNILLO PARCIALMENTE ROSCADO PG DIN 931 CL 8.8 M 12 X 150 GALVANIZADO BLANCO
BV244	BV024400	NR	VITE TCEI PG DIN 912 CL 8.8 M5 X 50 ZINGATA BIANCA	SCREW DIN 912 CL 8.8 M5 X 50	VIS DIN 912 CL 8.8 M5 X 50	SCHRAUBE DIN 912 CL 8.8 M5 X 50	TORNILLO DIN 912 CL 8.8 M5 X 50
BV245	BV024500	NR	VITE TE PARZIALE FILETTO PG DIN 931 CL 8.8 M 8 X 110 Z.BIANCA	SCREW PARTIAL THREAD DIN 931 PG CL 8.8 M 8 X 110 Z. WHITE	VIS PARTIELLEMENT FILETÉE DIN 931 PG CL 8.8 M 8 X 110 Z. BLANC	TEILGEWINDESCHRAUBE DIN 931 PG CL 8.8 M 8 X 110 Z. WEIß	TORNILLO PARCIALMENTE ROSCADO PG DIN 931 CL 8.8 M 8 X 110 GALVANIZADO BLANCO
BV246	BV024600	NR	VITE TE PARZIALE FILETTO PG DIN 931 CL 8.8 M 8 X 40 Z.BIANCA	SCREW PARTIAL THREAD DIN 931 PG CL 8.8 M 8 X 40 Z. WHITE	VIS PARTIELLEMENT FILETÉE DIN 931 PG CL 8.8 M 8 X 40 Z. BLANC	TEILGEWINDESCHRAUBE DIN 931 PG CL 8.8 M 8 X 40 Z. WEIß	TORNILLO PARCIALMENTE ROSCADO PG DIN 931 CL 8.8 M 8 X 40 GALVANIZADO BLANCO
BV247	BV024700	NR	VITE TE TUTTO FILETTO PG DIN 933 CL 8.8 M 5 X 50 Z.D.BIANCA	SCREW ALL THREAD DIN 933 PG CL 8.8 M 5 X 50 ZD WHITE	VIS ENTIÈREMENT FILETÉE DIN 933 CL 8.8 M 5 X 50 GALVANISATION BLANCHE	SCHRAUBE	TORNILLO
BV248	BV024800	NR	VITE TCEI PG DIN 912 CL 8.8 M5 X 18 Z. BIANCA	SCREW DIN 912 CL 8.8 M5 X 18 Z. WHITE	VIS DIN 912 CL 8.8 M5 X 18	SCHRAUBE DIN 912 CL 8.8 M5 X 18	TORNILLO DIN 912 CL 8.8 M5 X 18

POS	Codice	U.M.	 Descrizione	 Description	 Designation	 Benennung	 Descripción
BV249	BV024900	NR	VITE TSPEI PG DIN 7991 CL 10.9 M 5 X 65 Z.BIANCA	TSPEI PG SCREW DIN 7991 CL 10.9 M 5 X 65 Z. WHITE	VIS TSPEI PG DIN 7991 CL 10.9 M 5 X 65 GALVANISATION BLANCHE	SCHRAUBE	TORNILLO
BV251	BV025100	NR	VITE TSPEI PG DIN 7991 CL 10.9 M 8 X 35 Z.BIANCA	TSPEI PG SCREW DIN 7991 CL 10.9 M 8 X 35 Z. WHITE	VIS TSPEI PG DIN 7991 CL 10.9 M 8 X 35 GALVANISATION BLANCHE	SCHRAUBE	TORNILLO
BV252	BV025200	NR	VITE TE TUTTO FILETTO PG DIN 933 CL 10.9 M 12 X 40 Z.D.BIANCA	SCREW ALL THREAD DIN 933 PG CL 10.9 M 12 X 40 ZD WHITE	VIS ENTIÈREMENT FILETÉE DIN 933 CL 10.9 M 12 X 40 GALVANISATION BLANCHE	SCHRAUBE	TORNILLO
BV253	BV025300	NR	VITE TBEI PG ISO 7380 M 6 X 55 Z.BIANCA	HEX SOCKET SCREW ISO 7380 PG M 6 X 55 Z. WHITE	VIS ISO 7380 PG M 6 X 55 Z. BLANC	SCHRAUBE ISO 7380 PG M 6 X 55 Z. WEIß	TORNILLO TBEI PG ISO 7380 M 6 X 55 GALVANIZADO BLANCO
BV254	BV025400	NR	VITE TE TUTTO FILETTO PG DIN 933 CL 10.9 M 10 X 35 Z.D.BIANCA	SCREW ALL THREAD DIN 933 PG CL 10.9 M 10 X 35 ZD WHITE	VIS ENTIÈREMENT FILETÉE DIN 933 CL 10.9 M 10 X 35 GALVANISATION BLANCHE	SCHRAUBE	TORNILLO
BV255	BV025500	NR	VITE TE TUTTO FILETTO PG DIN 933 CL 12.9 M 14 X 55 Z.D.BIANCA	SCREW ALL THREAD DIN 933 PG CL 12.9 M 14 X 55 ZD WHITE	VIS ENTIÈREMENT FILETÉE DIN 933 CL 12.9 M 14 X 55 GALVANISATION BLANCHE	SCHRAUBE	TORNILLO
BV256	BV025600	NR	VITE TESTA SVASATA CROCE AUTOFILETTANTE 6 X 25	SCREW HEAD CROSS COUNTERSUNK SELF TAPPING 6 X 25			
BV257	BV025700	NR	VITE TE TUTTO FILETTO PG DIN 933 CL 8.8 M14 X 30 Z.BIANCA	SCREW ALL THREAD DIN 933 PG CL 8.8 M14 X 30 Z. WHITE	VIS ENTIÈREMENT FILETÉE DIN 933 PG CL 8.8 M14 X 30 Z. BLANC	VOLLGEWINDESCHRAUBE DIN 933 PG CL 8.8 M14 X 30 Z. WEIß	TORNILLO TOTALMENTE ROSCADO PG DIN 933 CL 8.8 M14 X 30 GALVANIZADO BLANCO
BV258	BV025800	NR	VITE TE TUTTO FILETTO PG DIN 933 CL 10.9 M 12 X 35 Z.D.BIANCA	SCREW ALL THREAD DIN 933 PG CL 10.9 M 12 X 35 ZD WHITE	VIS ENTIÈREMENT FILETÉE DIN 933 CL 10.9 M 12 X 35 GALVANISATION BLANCHE	SCHRAUBE	TORNILLO
BV259	BV025900	NR	VITE TE TUTTO FILETTO PG DIN 933 CL 8.8 M 16 X 45 Z.BIANCA	SCREW ALL THREAD DIN 933 PG CL 8.8 M16 X 45 Z. WHITE	VIS ENTIÈREMENT FILETÉE DIN 933 PG CL 8.8 M16 X 45 Z. BLANC	VOLLGEWINDESCHRAUBE DIN 933 PG CL 8.8 M16 X 45 Z. WEIßE	VIS TOTALMENTE ROSCADO DIN 933 CL 8.8 M16 X 45 GALVANIZADO BLANCO
BV260	BV026000	NR	VITE TCEI PG DIN 912 CL 10.9 M 12 X 30 ZINCATA BIANCA	SCREW DIN 912 CL 10.9 M 12 X 30	VIS DIN 912 CL 12.9 M 10 X 30	SCHRAUBE DIN 912 CL 10.9 M 12 X 30	TORNILLO TCEI PG DIN 912 CL 10.9 M 12 X 30
BV261	BV026100	NR	VITE TCEI PG DIN 912 CL 10.9 M 12 X 20 ZINCATA BIANCA	SCREW DIN 912 CL 10.9 M 12 X 20	VIS DIN 912 CL 12.9 M 10 X 20	SCHRAUBE DIN 912 CL 10.9 M 12 X 20	TORNILLO TCEI PG DIN 912 CL 10.9 M 12 X 20

POS	Codice	U.M.	 Descrizione	 Description	 Designation	 Benennung	 Descripción
BV262	BV026200	NR	VITE TCEI PG DIN 912 CL 12.9 M14 X 35 GEOMET 321A	SCREW DIN 912 CL 12.9 M14 X 35 GEOMET 321A	VIS TCEI PG DIN 912 CL 12.9 M14 X 35 GEOMET 321A	SCHRAUBE DIN 912 CL 12.9 M14 X 35 GEOMET 321A	TORNILLO DIN 912 CL 12.9 M14 X 35 GEOMET 321A
BV263	BV026300	NR	VITE TCEI PG DIN 912 CL 12.9 M14 X 3 GEOMET 321A	SCREW DIN 912 CL 12.9 M14 X 3 GEOMET 321A	VIS TCEI PG DIN 912 CL 12.9 M14 X 3 GEOMET 321A	SCHRAUBE DIN 912 CL 12.9 M14 X 3 GEOMET 321A	TORNILLO DIN 912 CL 12.9 M14 X 30 GEOMET 321A
BV264	BV026400	NR	VITE TSPEI PG DIN 7991 CL 10.9 M 12 X 25 Z.BIANCA	TSPEI PG SCREW DIN 7991 CL 10.9 M12 X 25 Z. WHITE	VIS TSPEI PG DIN 7991 CL 10.9 M 12 X 25 GALVANISATION BLANCHE	SCHRAUBE	TORNILLO
BV265	BV026500	NR	VITE TE PARZIALE FILETTO PG DIN 931 CL 10.9 M 16 X 180 GEOMET 321A	SCREW PARTIAL THREAD DIN 931 PG CL 10.9 M 16 X 180 GEOMET 321A	VIS PARTIELLEMENT FILETÉE DIN 931 CL 10.9 M 16 X 180 GEOMET 321A	SCHRAUBE	TORNILLO
BV266	BV026600	NR	VITE TE TUTTO FILETTO PG DIN 933 CL 8.8 M8 X 10 Z.BIANCA	SCREW ALL THREAD DIN 933 PG CL 8.8 M8 X 10 Z. WHITE	VIS ENTIÈREMENT FILETÉE DIN 933 PG CL 8.8 M8 X 10 Z. BLANC	VOLLGEWINDESCHRAUBE DIN 933 PG CL 8.8 M8 X 10 Z. WEIß	TORNILLO TOTALMENTE ROSCADO PG DIN 933 CL 8.8 M8 X 10 GALVANIZADO BLANCO
BV267	BV026700	NR	VITE TCEI PG DIN 912 CL 8.8 M 12 X 40	SCREW DIN 912 CL 9.8 M 12 X 40	VIS DIN 912 CL 8.8 M 12 X 40	SCHRAUBE DIN 912 CL 8.8 M 12 X 40	TORNILLO DIN 912 CL 8.8 M 12 X 40
BV268	BV026800	NR	VITE TE PARZIALE FILETTO PG DIN 931 CL 8.8 M 12 X 140 Z.BIANCA	SCREW PARTIAL THREAD DIN 931 PG CL 8.8 M 12 X 140 Z. WHITE	VIS PARTIELLEMENT FILETÉE DIN 931 PG CL 8.8 M 12 X 140 Z. BLANC	TEILGEWINDESCHRAUBE DIN 931 PG CL 8.8 M 12 X 140 Z. WEIß	TORNILLO PARCIALMENTE ROSCADO PG DIN 931 CL 8.8 M 12 X 140 GALVANIZADO BLANCO
BV269	BV026900	NR	VITE TC CROCE PG DIN 7985 CL 4.8 M 6 X 25 Z.BIANCA	SCREW DIN 7985 CL 4.8 M 6 X 25	VIS CROIX DIN 7985 CL 4.8 M 6 X 25 GALVANISATION BLANCHE	SCHRAUBE	TORNILLO
BV270	BV027000	NR	VITE TCEI PG DIN 912 CL 8.8 M 12 X 40	SCREW DIN 912 CL 9.8 M 12 X 40	VIS DIN 912 CL 8.8 M 12 X 40	SCHRAUBE DIN 912 CL 8.8 M 12 X 40	TORNILLO DIN 912 CL 8.8 M 12 X 40
BV271	BV027100	NR	TCEI UNC ASME/ANSI B18.3 ASTM A 574 1/2 X 1"1/4 GEOMET	TCEI UNC ASME/ANSI B18.3 ASTM A 574 1/2 X 1"1/4 GEOMET	TCEI UNC ASME/ANSI B18.3 ASTM A 574 1/2 X 1"1/4 GEOMET	TCEI UNC ASME/ANSI B18.3 ASTM A 574 1/2 X 1"1/4 GEOMET	TCEI UNC ASME/ANSI B18.3 ASTM A 574 1/2 X 1"1/4 GEOMET
BV272	BV027200	NR	TCEI UNC ASME/ANSI B18.3 ASTM A 574 1/4-20 X 1"1/2 GEOMET	TCEI UNC ASME/ANSI B18.3 ASTM A 574 1/4-20 X 1"1/2 GEOMET	TCEI UNC ASME/ANSI B18.3 ASTM A 574 1/4-20 X 1"1/2 GEOMET	TCEI UNC ASME/ANSI B18.3 ASTM A 574 1/4-20 X 1"1/2 GEOMET	TCEI UNC ASME/ANSI B18.3 ASTM A 574 1/4-20 X 1"1/2 GEOMET
BV273	BV027300	NR	VITE TE PARZIALE FILETTO PG DIN 931 CL 8.8 M 12 X 70 Z.BIANCA	SCREW PARTIAL THREAD DIN 931 PG CL 8.8 M 12 X 70 Z. WHITE	VIS PARTIELLEMENT FILETÉE DIN 931 PG CL 8.8 M 12 X 70 Z. BLANC	TEILGEWINDESCHRAUBE DIN 931 PG CL 8.8 M 12 X 70 Z. WEIß	TORNILLO PARCIALMENTE ROSCADO PG DIN 931 CL 8.8 M 12 X 70 GALVANIZADO BLANCO





POS	Codice	U.M.	 Descrizione	 Description	 Designation	 Benennung	 Descripción
BV274	BV027400	NR	VITE TE TUTTO FILETTO PG DIN 933 CL 8.8 M 5 X 20 Z.D.BIANCA	SCREW ALL THREAD DIN 933 PG CL 8.8 M 5 X 20 ZD WHITE	VIS ENTIÈREMENT FILETÉE DIN 933 CL 8.8 M 5 X 20 GALVANISATION BLANCHE	SCHRAUBE	TORNILLO
BV275	BV027500	NR	VITE TSPEI PG DIN 7991 CL 10.9 M 6 X 70 Z.BIANCA	TSPEI PG SCREW DIN 7991 CL 10.9 M 6 X 70 Z. WHITE	VIS DIN 7991 CL 10.9 M 6 X 70 Z. BLANC	TSPEI PG SCHRAUBE DIN 7991 CL 10.9 M 6 X 70 Z. WEIß	TORNILLO TSPEI PG DIN 7991 CL 10.9 M 6 X 70 GALVANIZADO BLANCO
BV276	BV027600	NR	VITE TCEI PG DIN 912 CL 8.8 M 5 X 14 Z.BIANCA	SCREW DIN 912 PG CL 8.8 M 5 X 14 Z. WHITE	VIS DIN 912 CL 8.8 M 5 X 14 GALVANISATION BLANCHE	SCHRAUBE	TORNILLO
BV277	BV027700	NR	VITE TBEI PG ISO 7380 CL 10.9 M 10 X 35 Z.BIANCA	HEX SOCKET SCREW ISO 7380 PG CL 10.9 M 10 X 35 Z. WHITE	VIS ISO 7380 PG CL 10.9 M 10 X 35 Z. BLANC	SCHRAUBE ISO 7380 PG CL 10.9 M 10 X 35 Z. WEIß	TORNILLO TBEI PG ISO 7380 CL 10.9 M 10 X 35 GALVANIZADO BLANCO
BV278	BV027800	NR	VITE TE PARZIALE FILETTO PG DIN 931 CL 10.9 M 16 X 60	SCREW PARTIAL THREAD DIN 931 PG CL 10.9 M 16 X 60	VIS TE PARTIELLEMENT FILETÉE PG DIN 931 CL 10.9 M 16 X 60	TEILGEWINDESCHRAUBE DIN 931 PG CL 10.9 M 16 X 60	TORNILLO PARCIALMENTE ROSCADO PG DIN 931 CL 10.9 M 16 X 60
BV279	BV027900	NR	VITE TE PARZIALE FILETTO PG DIN 931 CL 8.8 M 12 X 60 Z.BIANCA	SCREW PARTIAL THREAD DIN 931 PG CL 8.8 M 12 X 60 Z. WHITE	VIS PARTIELLEMENT FILETÉE DIN 931 PG CL 8.8 M 12 X 60 Z. BLANC	TEILGEWINDESCHRAUBE DIN 931 PG CL 8.8 M 12 X 60 Z. WEIß	TORNILLO PARCIALMENTE ROSCADO PG DIN 931 CL 8.8 M 12 X 60 GALVANIZADO BLANCO
BV280	BV028000	NR	VITE TE PARZIALE FILETTO PG DIN 931 CL 8.8 M 12 X 55 Z.BIANCA	SCREW PARTIAL THREAD DIN 931 PG CL 8.8 M 12 X 55 Z. WHITE	VIS PARTIELLEMENT FILETÉE DIN 931 PG CL 8.8 M 12 X 55 Z. BLANC	TEILGEWINDESCHRAUBE DIN 931 PG CL 8.8 M 12 X 55 Z. WEIß	TORNILLO PARCIALMENTE ROSCADO PG DIN 931 CL 8.8 M 12 X 55 GALVANIZADO BLANCO
BV281	BV028100	NR	VITE TE PARZIALE FILETTO PG DIN 931 CL 8.8 M 14 X 45 Z.BIANCA	SCREW PARTIAL THREAD DIN 931 PG CL 8.8 M 14 X 45 Z. WHITE	VIS PARTIELLEMENT FILETÉE DIN 931 PG CL 8.8 M 14 X 45 Z. BLANC	TEILGEWINDESCHRAUBE DIN 931 PG CL 8.8 M 14 X 45 Z. WEIß	TORNILLO PARCIALMENTE ROSCADO PG DIN 931 CL 8.8 M 14 X 45 GALVANIZADO BLANCO
BV282	BV028200	NR	VITE TE TUTTO FILETTO PG DIN 933 CL 8.8 M 8 X 55 Z.BIANCA	SCREW ALL THREAD DIN 933 PG CL 8.8 M 8 X 55 Z. WHITE	VIS TE ENTIÈREMENT FILETÉE PG DIN 933 CL 8.8 M 8 X 55 Z.BLANC	VOLLGEWINDESCHRAUBE DIN 933 PG CL 8.8 M 8 X 55 Z. WEIß	TORNILLO TOTALMENTE ROSCADO PG DIN 933 CL 8.8 M 8 X 55 GALVANIZADO BLANCO
BV283	BV028300	NR	VITE TCEI INTERAMENTE FILETTATA PG CL 8.8 M 8 X 45 Z.BIANCA	SCREW TCEI FULLY THREADED PG CL 8.8 M 8 X 45 Z. WHITE	VIS	SCHRAUBE	TORNILLO
BV284	BV028400	NR	VITE TCEI PG DIN 912 CL 8.8 M 4 X 35 Z.BIANCA	SCREW TCEI DIN 912 CL 8.8 M 4 X 35 Z. WHITE	VIS	SCHRAUBE	TORNILLO





POS	Codice	U.M.	 Descrizione	 Description	 Designation	 Benennung	 Descripción
BV285	BV028500	NR	VITE TCEI PG DIN 912 CL 8.8 M 4 X 50 Z.BIANCA	SCREW TCEI DIN 912 CL 8.8 M 4 X 50 Z. WHITE	VIS	SCHRAUBE	TORNILLO
BV286	BV028600	NR	VITE TCEI PG DIN 912 CL 8.8 M 5 X 25 Z.BIANCA	SCREW TCEI DIN 912 CL 8.8 M 5 X 25 Z. WHITE	VIS	SCHRAUBE	TORNILLO
BV287	BV028700	NR	VITE TCEI PG DIN 912 CL 8.8 M 5 X 50 GEO 321 A	SCREW TCEI DIN 912 CL 8.8 M 5 X 50 GEO 321 A	VIS	SCHRAUBE	TORNILLO
BV293	BV029300	NR	VITE TCEI PG DIN 912 CL 8.8 M 8 X 90 Z.BIANCA	SCREW TCEI DIN 912 CL 8.8 M 8 X 90 Z. WHITE	VIS	SCHRAUBE	TORNILLO
BV294	BV029400	NR	VITE TCEI PG DIN 912 CL 8.8 M 10 X 16 Z.BIANCA	SCREW TCEI DIN 912 CL 8.8 M 10 X 16 Z. WHITE	VIS	SCHRAUBE	TORNILLO
BV295	BV029500	NR	VITE TCEI PG DIN 912 CL 8.8 M 10 X 20 Z.BIANCA	SCREW TCEI DIN 912 CL 8.8 M 10 X 20 Z. WHITE	VIS	SCHRAUBE	TORNILLO
BV297	BV029700	NR	VITE TCEI PG DIN 912 CL 8.8 M 10 X 40 Z.BIANCA	SCREW TCEI DIN 912 CL 8.8 M 10 X 40 Z. WHITE	VIS	SCHRAUBE	TORNILLO
BV298	BV029800	NR	VITE TCEI PG DIN 912 CL 8.8 M 10 X 65 Z.BIANCA	SCREW TCEI DIN 912 CL 8.8 M 10 X 65 Z. WHITE	VIS	SCHRAUBE	TORNILLO
BV299	BV029900	NR	VITE TCEI PG DIN 912 CL 8.8 M 10 X 120 Z.BIANCA	SCREW TCEI DIN 912 CL 8.8 M 10 X 120 Z. WHITE	VIS	SCHRAUBE	TORNILLO
BV300	BV030000	NR	VITE TCEI PG DIN 912 CL 8.8 M 12 X 30 Z.BIANCA	VITE TCEI PG DIN 912 CL 8.8 M 12 X 30 Z.BIANCA	VIS	SCHRAUBE	TORNILLO
BV301	BV030100	NR	VITE TCEI UNC ASME/ANSI B18.3 ASTM A 574 1/4 X 1"3/4	TCEI SCREW UNC ASME / ANSI B18.3 ASTM A 574 1/4 X 1 "3/4	VIS	SCHRAUBE	TORNILLO
BV303	BV030300	NR	VITE TCEI UNC ASME/ANSI B18.3 ASTM A 574 5/16 X 3/4	TCEI SCREW UNC ASME / ANSI B18.3 ASTM A 574 5/16 X 3/4	VIS	SCHRAUBE	TORNILLO
BV304	BV030400	NR	VITE TCEI PG DIN 912 CL 12.9 M 10 X 75	SCREW TCEI DIN 912 CL 12.9 M 10 X 75	VIS	SCHRAUBE	TORNILLO
BV305	BV030500	NR	VITE TCEI PG DIN 912 CL 12.9 M 14 X 55	SCREW TCEI DIN 912 CL 12.9 M 14 X 55	VIS	SCHRAUBE	TORNILLO
BV306	BV030600	NR	VITE TCEI BASSA PG DIN 7984 CL 10.9 M 12 X 20 Z.D.BIANCA	LOW TCEI SCREW DIN 7984 CL 10.9 M 12 X 20 Z.D. WHITE	VIS	SCHRAUBE	TORNILLO

POS	Codice	U.M.	 Descrizione	 Description	 Designation	 Benennung	 Descripción
BV307	BV030700	NR	VITE TSPEI TUTTO FILETTO PG DIN 7991 CL 10.9 M 12 X 90 ZIC. BIANCO DEID.	TSPEI SCREW FULLY THREADED DIN 7991 CL 10.9 M 12 X 90 ZIC. DEID WHITE.	VIS	SCHRAUBE	TORNILLO
BV308	BV030800	NR	VITE TSPEI TUTTO FIL. PG DIN 7991 CL 10.9 M 14 X 100 ZIC. BIANCO DEID.	TSPEI SCREW ALL THREAD DIN 7991 CL 10.9 M 14 X 100 ZIC. DEID WHITE.	VIS	SCHRAUBE	TORNILLO
BV309	BV030900	NR	VITE TSPEI PG DIN 7991 CL 10.9 M 4 X 25 ZIC. BIANCO DEID.	SCREW TSPEI DIN 7991 CL 10.9 M 4 X 25 ZIC. DEID WHITE.	VIS	SCHRAUBE	TORNILLO
BV310	BV031000	NR	VITE TSPEI PG DIN 7991 CL 10.9 M 5 X 40	SCREW TSPEI DIN 7991 CL 10.9 M 5 X 40	VIS	SCHRAUBE	TORNILLO
BV311	BV031100	NR	VITE TSPEI PG DIN 7991 CL 10.9 M 5 X 80 ZIC. BIANCO DEID.	SCREW TSPEI DIN 7991 CL 10.9 M 5 X 80 ZIC. DEID WHITE.	VIS	SCHRAUBE	TORNILLO
BV312	BV031200	NR	VITE TSPEI PG DIN 7991 CL 10.9 M 8 X 20 ZIC. BIANCO DEID.	SCREW TSPEI DIN 7991 CL 10.9 M 8 X 20 ZIC. DEID WHITE.	VIS	SCHRAUBE	TORNILLO
BV313	BV031300	NR	VITE TSPEI PG DIN 7991 CL 10.9 M 16 X 50 ZIC. BIANCO DEID.	SCREW TSPEI DIN 7991 CL 10.9 M 16 X 50 ZIC. DEID WHITE.	VIS	SCHRAUBE	TORNILLO
BV315	BV031500	NR	VITE TE UNC ANSI B18.2.1 GR.5 5/8 X 3"1/2	SCREW TE UNC ANSI B18.2.1 GR.5 5/8 X 3 1/2 "	VIS	SCHRAUBE	TORNILLO
BV316	BV031600	NR	VITE TE TUTTO FILETTO PG DIN 933 CL 8.8 M 4 X 40 Z.BIANCA	ALL SCREW TE THREAD DIN 933 CL 8.8 M 4 X 40 Z. WHITE	VIS	SCHRAUBE	TORNILLO
BV317	BV031700	NR	VITE TE TUTTO FILETTO PG DIN 933 CL 8.8 M 5 X 55 Z.BIANCA	ALL SCREW TE THREAD DIN 933 CL 8.8 M 5 X 55 Z. WHITE	VIS	SCHRAUBE	TORNILLO
BV318	BV031800	NR	VITE TE TUTTO FILETTO PG DIN 933 CL 8.8 M 6 X 10 Z.BIANCA	ALL SCREW TE THREAD DIN 933 CL 8.8 M 6 X 10 Z. WHITE	VIS	SCHRAUBE	TORNILLO
BV319	BV031900	NR	VITE TE TUTTO FILETTO PG DIN 933 CL 8.8 M 6 X 50 Z.BIANCA	ALL SCREW TE THREAD DIN 933 CL 8.8 M 6 X 50 Z. WHITE	VIS	SCHRAUBE	TORNILLO
BV320	BV032000	NR	VITE TE TUTTO FILETTO PG DIN 933 CL 8.8 M 8 X 45 Z.BIANCA	ALL SCREW TE THREAD DIN 933 CL 8.8 M 8 X 45 Z. WHITE	VIS	SCHRAUBE	TORNILLO

POS	Codice	U.M.	 Descrizione	 Description	 Designation	 Benennung	 Descripción
BV321	BV032100	NR	VITE TE TUTTO FILETTO PG DIN 933 CL 8.8 M 8 X 65 Z.BIANCA	ALL SCREW TE THREAD DIN 933 CL 8.8 M 8 X 65 Z. WHITE	VIS	SCHRAUBE	TORNILLO
BV322	BV032200	NR	VITE TE TUTTO FILETTO PG DIN 933 CL 8.8 M 8 X 80 Z.BIANCA	ALL SCREW TE THREAD DIN 933 CL 8.8 M 8 X 80 Z. WHITE	VIS	SCHRAUBE	TORNILLO
BV323	BV032300	NR	VITE TE TUTTO FILETTO PG DIN 933 CL 8.8 M 10 X 75 Z.BIANCA	ALL SCREW TE THREAD DIN 933 CL 8.8 M 10 X 75 Z. WHITE	VIS	SCHRAUBE	TORNILLO
BV324	BV032400	NR	VITE TE TUTTO FILETTO PG DIN 933 CL 8.8 M 12 X 75 Z.BIANCA	ALL SCREW TE THREAD DIN 933 CL 8.8 M 12 X 75 Z. WHITE	VIS	SCHRAUBE	TORNILLO
BV326	BV032600	NR	VITE TE PARZIALE FILETTO PG DIN 931 CL 8.8 M 8 X 90 Z.BIANCA	SCREW TE PARTIAL THREAD DIN 931 CL 8.8 M 8 X 90 Z. WHITE	VIS	SCHRAUBE	TORNILLO
BV327	BV032700	NR	VITE TE PARZIALE FILETTO PG DIN 931 CL 8.8 M 8 X 100 Z.BIANCA	SCREW TE PARTIAL THREAD DIN 931 CL 8.8 M 8 X 100 Z. WHITE	VIS	SCHRAUBE	TORNILLO
BV329	BV032900	NR	VITE TE PARZIALE FILETTO PG DIN 931 CL 8.8 M 10 X 40 Z.BIANCA	SCREW TE PARTIAL THREAD DIN 931 CL 8.8 M 10 X 40 Z. WHITE	VIS	SCHRAUBE	TORNILLO
BV330	BV033000	NR	VITE TE PARZIALE FILETTO PG DIN 931 CL 8.8 M 10 X 45 Z.BIANCA	SCREW TE PARTIAL THREAD DIN 931 CL 8.8 M 10 X 45 Z. WHITE	VIS	SCHRAUBE	TORNILLO
BV331	BV033100	NR	VITE TE PARZIALE FILETTO PG DIN 931 CL 8.8 M 10 X 60 Z.BIANCA	SCREW TE PARTIAL THREAD DIN 931 CL 8.8 M 10 X 60 Z. WHITE	VIS	SCHRAUBE	TORNILLO
BV332	BV033200	NR	VITE TE PARZIALE FILETTO PG DIN 931 CL 8.8 M 12 X 40 Z.BIANCA	SCREW TE PARTIAL THREAD DIN 931 CL 8.8 M 12 X 40 Z. WHITE	VIS	SCHRAUBE	TORNILLO
BV333	BV033300	NR	VITE TE PARZIALE FILETTO PG DIN 931 CL 8.8 M 12 X 45 Z.BIANCA	SCREW TE PARTIAL THREAD DIN 931 CL 8.8 M 12 X 45 Z. WHITE	VIS	SCHRAUBE	TORNILLO

POS	Codice	U.M.	 Descrizione	 Description	 Designation	 Benennung	 Descripción
BV334	BV033400	NR	VITE TE PARZIALE FILETTO PG DIN 931 CL 8.8 M 12 X 50 Z.BIANCA	SCREW TE PARTIAL THREAD DIN 931 CL 8.8 M 12 X 50 Z. WHITE	VIS	SCHRAUBE	TORNILLO
BV337	BV033700	NR	VITE TE PARZIALE FILETTO PG DIN 931 CL 8.8 M 14 X 60 Z.BIANCA	SCREW TE PARTIAL THREAD DIN 931 CL 8.8 M 14 X 60 Z. WHITE	VIS	SCHRAUBE	TORNILLO
BV338	BV033800	NR	VITE TE PARZIALE FILETTO PG DIN 931 CL 8.8 M 14 X 120 Z.BIANCA	SCREW TE PARTIAL THREAD DIN 931 CL 8.8 M 14 X 120 Z. WHITE	VIS	SCHRAUBE	TORNILLO
BV339	BV033900	NR	VITE TE PARZIALE FILETTO PG DIN 931 CL 8.8 M 16 X 50 Z.BIANCA	SCREW TE PARTIAL THREAD DIN 931 CL 8.8 M 16 X 50 Z. WHITE	VIS	SCHRAUBE	TORNILLO
BV340	BV034000	NR	VITE TE PARZIALE FILETTO PG DIN 931 CL 8.8 M 16 X 65 Z.BIANCA	SCREW TE PARTIAL THREAD DIN 931 CL 8.8 M 16 X 65 Z. WHITE	VIS	SCHRAUBE	TORNILLO
BV341	BV034100	NR	VITE TE TUTTO FILETTO PF DIN 961 CL 8.8 M 8 X 1 X 35 Z.BIANCA	ALL SCREW TE THREAD DIN 961 CL 8.8 M 8 X 1 X 35 Z. WHITE	VIS	SCHRAUBE	TORNILLO
BV342	BV034200	NR	VITE TE TUTTO FILETTO PF DIN 961 CL 8.8 M 20 X 1,5 X 35 Z.BIANCO	ALL SCREW TE THREAD DIN 961 CL 8.8 M 20 X 1.5 X 35 Z. WHITE	VIS	SCHRAUBE	TORNILLO
BV344	BV034400	NR	VITE TE TUTTO FILETTO PG DIN 933 CL 10.9 M 10 X 30 Z.D.BIANCA	ALL SCREW TE THREAD DIN 933 CL 10.9 M 10 X 30 Z.D. WHITE	VIS	SCHRAUBE	TORNILLO
BV346	BV034600	NR	VITE TE TUTTO FILETTO PG DIN 933 CL 10.9 M 16 X 65 GEO 321 A	ALL SCREW TE THREAD DIN 933 CL 10.9 M 16 X 65 GEO 321 A	VIS	SCHRAUBE	TORNILLO
BV347	BV034700	NR	VITE TE PARZIALE FILETTO PG DIN 931 CL 10.9 M 12 X 40 Z.D.BIANCA	SCREW TE PARTIAL THREAD DIN 931 CL 10.9 M 12 X 40 Z.D. WHITE	VIS	SCHRAUBE	TORNILLO
BV348	BV034800	NR	VITE TE PARZIALE FILETTO PG DIN 931 CL 10.9 M 12 X 75 Z.D.BIANCA	SCREW TE PARTIAL THREAD DIN 931 CL 10.9 M 12 X 75 Z.D. WHITE	VIS	SCHRAUBE	TORNILLO

POS	Codice	U.M.	 Descrizione	 Description	 Designation	 Benennung	 Descripción
BV349	BV034900	NR	VITE TE PARZIALE FILETTO PG DIN 931 CL 10.9 M 16 X 45 Z.D.BIANCA	SCREW TE PARTIAL THREAD DIN 931 CL 10.9 M 16 X 45 Z.D. WHITE	VIS	SCHRAUBE	TORNILLO
BV350	BV035000	NR	VITE TE PARZIALE FILETTO PG DIN 931 CL 10.9 M 16 X 75 Z.D.BIANCA	SCREW TE PARTIAL THREAD DIN 931 CL 10.9 M 16 X 75 Z.D. WHITE	VIS	SCHRAUBE	TORNILLO
BV351	BV035100	NR	VITE TE PARZIALE FILETTO PG DIN 931 CL 10.9 M 16 X 180	SCREW TE PARTIAL THREAD DIN 931 CL 10.9 M 16 X 180	VIS	SCHRAUBE	TORNILLO
BV352	BV035200	NR	VITE TE PARZIALE FILETTO PG DIN 931 CL 10.9 M 16 X 230 GEO 321 A	SCREW TE PARTIAL THREAD DIN 931 CL 10.9 M 16 X 230 GEO 321 A	VIS	SCHRAUBE	TORNILLO
BV354	BV035400	NR	VITE TE TUTTO FILETTO PF DIN 961 CL 10.9 M 12 X 1,25 X 35 Z.D.BIANCA	ALL SCREW TE THREAD DIN 961 CL 10.9 M 12 X 1.25 X 35 Z.D. WHITE	VIS	SCHRAUBE	TORNILLO
BV355	BV035500	NR	VITE TC CROCE PG DIN 7985 CL 4.8 M 4 X 10 Z.BIANCA	SCREW TC DIN 7985 CROSS CL 4.8 M 4 X 10 Z. WHITE	VIS	SCHRAUBE	TORNILLO
BV356	BV035600	NR	VITE TC CROCE PG DIN 7985 CL 4.8 M 5 X 22 Z.BIANCA	SCREW TC DIN 7985 CROSS CL 4.8 M 5 X 22 Z. WHITE	VIS	SCHRAUBE	TORNILLO
BV359	BV035900	NR	VITE TE 8.8 ZINCATE M 6 X 65 PARZIALE	SCREW TE 8.8 GALVANIZED M 6 X 65 PARTIAL	VIS	SCHRAUBE	TORNILLO
BV360	BV036000	NR	VITE TE 8.8 ZINCATE M 14 X 65 PARZIALE	SCREW TE 8.8 GALVANIZED M 14 X 65 PARTIAL	VIS	SCHRAUBE	TORNILLO
BV361	BV036100	NR	VITE TBEI PG ISO 7380 CL 10.9 M 5 X 20 Z.BIANCA	HEX SOCKET SCREW ISO 7380 PG CL 10.9 M 5 X 20 Z. WHITE	VIS ISO 7380 CL 10.9 M 5 X 20 GALVANISATION BLANCHE	SCHRAUBE	TORNILLO
BV362	BV036200	NR	VITE TSPEI PG DIN 7991 CL 10.9 M 6 X 35 Z.BIANCA	SCREW DIN 7991 CL 10.9 M 6 X 35 Z. WHITE			
BV363	BV036300	NR	VITE TC CROCE PG DIN 7985 CL 4.8 M 6 X 12 Z.BIANCA	CROSS HEAD SCREW DIN 7985 PG CL 4.8 M 6 X 12 Z. WHITE	VIS DIN 7985 CL 4.8 M 6 X 12 GALVANISATION BLANCHE	SCHRAUBE	TORNILLO
BV364	BV036400	NR	VITE TE PARZIALE FILETTO PG DIN 931 CL 10.9 M 16 X 160	SCREW PARTIAL THREAD DIN 931 PG CL 10.9 M 16 X 160	VIS TE PARTIELLEMENT FILETÉE PG DIN 931 CL 10.9 M 16 X 60	TEILGEWINDESCHRAUBE DIN 931 PG CL 10.9 M 16 X 160	TORNILLO PARCIALMENTE ROSCADO PG DIN 931 CL 10.9 M 16 X 160

POS	Codice	U.M.	 Descrizione	 Description	 Designation	 Benennung	 Descripción
BV365	BV036500	NR	VITE TSPEI PG DIN 7991 CL 10.9 M 10 X 25 Z.BIANCA	TSPEI PG SCREW DIN 7991 CL 10.9 M 10 X 25 Z. WHITE	VIS DIN 7991 CL 10.9 M 10 X 25 GALVANISATION BLANCHE	SCHRAUBE	TORNILLO
BV366	BV036600	NR	VITE TE TUTTO FILETTO PF DIN 961 CL 8.8 M 20 X 1,5 X 35 Z.BIANCO	ALL SCREW TE THREAD DIN 961 CL 8.8 M 20 X 1.5 X 35 Z. WHITE	VIS	SCHRAUBE	TORNILLO
BV367	BV036700	NR	VITE TE PARZIALE FILETTO PG DIN 931 CL 10.9 M 16 X 120	SCREW PARTIAL THREAD DIN 931 PG CL 10.9 M 16 X 120	VIS PARTIELLEMENT FILETÉE DIN 931 CL 10.9 M 16 X 120	SCHRAUBE	TORNILLO
BV368	BV036800	NR	VITE TSPEI PG DIN 7991 CL 10.9 M 8 X 16 Z.BIANCA	SCREW DIN 7991 CL 10.9 M 8 X 16 Z. WHITE	VIS DIN 7991 CL 10.9 M 8 X 16 GALVANISATION BLANCHE		
BV369	BV036900	NR	VITE TE PARZIALE FILETTO PG DIN 931 CL 8.8 M 6 X 90 Z.BIANCA	SCREW THREAD DIN 931 PG CL 8.8 M 6 X 90 Z. WHITE	VIS FILETÉE DIN 931 CL 8.8 M 6 X 90 GALVANISÉE BLANCHE	VOLLGEWINDESCHRAUBE DIN 931 PG CL 8.8 M 6 X 90 Z. WEIß	TORNILLO ROSCADO DIN 931 CL 8.8 M 6 X 90 GALVANIZADO BLANCO
BV370	BV037000	NR	VITE TBEI PG ISO 7380 CL 10.9 M 8 X 30 Z.BIANCA	HEX SOCKET SCREW ISO 7380 PG CL 10.9 M 8 X 30 Z. WHITE	VIS ISO 7380 PG CL 10.9 M 8 X 30 Z. BLANC	TBEI PG SCHRAUBE ISO 7380 CL 10.9 M 8 X 30 Z. WEIß	TORNILLO TBEI PG ISO 7380 CL 10.9 M 8 X 30 GALVANIZADO BLANCO
BV371	BV037100	NR	VITE TE TUTTO FILETTO PG DIN 933 CL 8.8 M 5 X 30 Z.BIANCA	SCREW ALL THREAD DIN 933 PG CL 8.8 M 5 X 30 Z. WHITE	VIS TE ENTIÈREMENT FILETÉE PG DIN 933 CL 8.8 M 5 X 30 Z.BLANC	VOLLGEWINDESCHRAUBE DIN 933 PG CL 8.8 M 5 X 30 Z. WEIß	TORNILLO TOTALMENTE ROSCADO PG DIN 933 CL 8.8 M 5 X 30 GALVANIZADO BLANCO
BV372	BV037200	NR	VITE TE TUTTO FILETTO PG DIN 933 CL 8.8 M 5 X 35 Z.BIANCA	SCREW ALL THREAD DIN 933 PG CL 8.8 M 5 X 35 Z. WHITE	VIS TE ENTIÈREMENT FILETÉE PG DIN 933 CL 8.8 M 5 X 35 Z.BLANC	VOLLGEWINDESCHRAUBE DIN 933 PG CL 8.8 M 5 X 35 Z. WEIß	TORNILLO TOTALMENTE ROSCADO PG DIN 933 CL 8.8 M 5 X 35 GALVANIZADO BLANCO
BV373	BV037300	NR	VITE TSPEI PG DIN 7991 CL 10.9 M 5 X 10 Z.BIANCA	TSPEI PG SCREW DIN 7991 CL 10.9 M 5 X 10 Z. WHITE	VIS DIN 7991 CL 10.9 M 5 X 10 GALVANISATION BLANCHE	SCHRAUBE	TORNILLO
BV374	BV037400	NR	VITE TE TUTTO FILETTO PG DIN 931 CL 8.8 M 20 X 130 Z.BIANCA	SCREW THREAD DIN 931 PG CL 8.8 M 20 X 130	VIS FILETÉE DIN 931 CL 8.8 M 20 X 130	SCHRAUBE	TORNILLO
BV375	BV037500	NR	VITE TSPEI PG DIN 7991 CL 10.9 M 8 X 120 Z.BIANCA	SCREW DIN 7991 CL 10.9 M 8 X 120 Z. WHITE	VIS DIN 7991 CL 10.9 M 8 X 120 GALVANISATION BLANCHE		
BV376	BV037600	NR	VITE TCEI PARZIALE FILETTO PG DIN 912 CL 8.8 M 6 X 65 Z.BIANCA	SCREW DIN 912 M6 X 65 CL 8.8 Z. WHITE	VIS DIN 912 CL 8.8 M 6 X 65 GALVANISATION BLANCHE	SCHRAUBE	TORNILLO







Viteria













Fasteners











POS	Codice	U.M.	Descrizione	Description	Designation	Benennung	Descripción
BV377	BV037700	NR	VITE TCEI PARZIALE FILETTO PG DIN 912 CL 8.8 M 6 X 85 Z.BIANCA	SCREW DIN 912 M6 X 85 CL 8.8 Z. WHITE	VIS DIN 912 CL 8.8 M 6 X 85 GALVANISATION BLANCHE	SCHRAUBE	TORNILLO
BV378	BV037800	NR	VITE TE TUTTO FILETTO PG DIN 933 INOX A2 M 4 X 25	SCREW ALL THREAD DIN 933 PG CL 8.8 M 4 X 25 INOX	VIS ENTièrement FILETÉE DIN 933 CL 8.8 M 4 X 25 INOX	SCHRAUBE	TORNILLO
BV379	BV037900	NR	VITE TBEI PG ISO 7380 CL 10.9 M 5 X 10 Z.BIANCA	HEX SOCKET SCREW ISO 7380 PG CL 10.9 M 5 X 10 Z. WHITE	VIS ISO 7380 CL 10.9 M 5 X 10 GALVANISATION BLANCHE	SCHRAUBE	TORNILLO





POS	Codice	U.M.	 Descrizione	 Description	 Designation	 Benennung	 Descripción
RB1	RB000100	NR	DADO PER OGIVA Ø=12	NUT FOR OGIVA Ø = 12	ÉCROU POUR OGIVE Ø=12	SCHRAUBENMUTTER FÜR OGIVA Ø = 12	TUERCA PARA OJIVA Ø=12
RD1	RD000100	NR	RACCORDO CORPO A "T" EO F(DKOL)-M-M 8L	FITTING BODY A "T" EO F (DKOL) M-M-8L	RACCORD CORP "T" EO F (DKOL) M-M-8L	T-ANSCHLUSSSTÜCK EO F (DKOL) M-M-8L	UNIÓN EN "T" EO F(DKOL)-M-M 8L
RD2	RD000200	NR	RACCORDO CORPO A "T" EO F(DKOL)-M-M 10L	FITTING BODY A "T" EO F (DKOL) M-M-10L	RACCORD EN "T" EO F(DKOL)-M-M 10L	ANSCHLUSS	CONEXION
RD3	RD000300	NR	RACCORDO CORPO A "T" EO F(DKOL)-M-M 12L	FITTING BODY A "T" EO F (DKOL) M-M-12L	RACCORD CORP "T" EO F(DKOL)-M-M 12L	T-ANSCHLUSSSTÜCK EO F (DKOL) M-M-12L	UNIÓN EN "T" EO F(DKOL)-M-M 12L
RD4	RD000400	NR	RACCORDO CORPO A "T" EO F(DKOL)-M-M 15L	FITTING BODY A "T" EO F (DKOL) M-M-15L	RACCORD CORPS EN "T" EO F(DKOL)-M-M 15L	T-ANSCHLUSSSTÜCK EO F (DKOL) M-M-15L	UNIÓN EN "T" EO F(DKOL)-M-M 15L
RD5	RD000500	NR	RACCORDO CORPO A "T" EO M-F(DKOL)-M 10L	FITTING BODY A "T" EO M-F (DKOL) M-10L	RACCORD CORPS EN "T" EO M-F (DKOL) M-10L	T-ANSCHLUSSSTÜCK EO M-F (DKOL) M-10L	UNIÓN EN "T" EO M-F(DKOL)-M 10L
RD6	RD000600	NR	RACCORDO CORPO A "T" EO M-F(DKOL)-M 12L	FITTING BODY A "T" EO M-F (DKOL) M-12L	RACCORD EN "T" EO M-F(DKOL)-M 12L	ANSCHLUSS	CONEXION
RD7	RD000700	NR	RACCORDO CORPO A "T" EO 8L M 14*1.5	FITTING BODY A "T" EO 8L M 14 * 1.5	RACCORD EN "T" EO 8L M 14*1.5	ANSCHLUSS	CONEXION
RD8	RD000800	NR	RACCORDO CORPO A "T" EO 10L M 16*1.5	FITTING BODY A "T" M 10L EO 16 * 1.5	RACCORD EN "T" EO 10L M 16*1.5	ANSCHLUSS	CONEXION
RD9	RD000900	NR	RACCORDO CORPO A "T" EO 28L M 36*2	FITTING BODY A "T" M 28L EO 36 * 2	RACCORD CORPS EN "T" M 28L EO 36 * 2	T-ANSCHLUSSSTÜCK M 28L EO 36 * 2	UNIÓN EN "T" EO 28L M 36*2
RD10	RD001000	NR	RACCORDO CORPO A "T" EO 28L M 36*2	FITTING BODY A "T" EO M-F (DKOL) M-10L	RACCORD CORPS EN "T" EO M-F (DKOL) M-10L	T-ANSCHLUSSSTÜCK EO M-F (DKOL) M-10L	UNIÓN EN "T" EO 28L M 36*2
RD11	RD001100	NR	RACCORDO CORPO A "T" EO M-F(DKOL)-M 10L	FITTING BODY A "T" EO M-F (DKOL) M-10L	RACCORD CORP EN "T" EO 28L M 36*2	T-ANSCHLUSSSTÜCK EO M-F (DKOL) M-10L	CUERPO EN "T" CODO EO M-F(DKOL)-M 10L
RD12	RD001200	NR	ADATTATORE "T" GAS M-FG-M 1/4 1/4 1/4	ADAPTOR	ADAPTATEUR	ADAPTER	ADAPTADOR
RG1	RG000100	NR	RACCORDO CORPO A GOMITO 10L MASCH.-FEMM. DKOL	ELBOW FITTING BODY 10L MASCH.-FEMM. DKOL	RACCORD CORPS À GENOUILLÈRE 10L MASCH.-FEMM. DKOL	WINKELSTÜCK	UNIÓN EN CODO 10L MACHO-HEMBRA DKOL
RG2	RG000200	NR	RACCORDO CORPO A GOMITO 12L MASCH.-FEMM. DKOL	ELBOW FITTING BODY 12L MASCH.-FEMM. DKOL	RACCORD COUDÉ 12L MÂLE-FEMELLE DKOL	ANSCHLUSS	CONEXION





POS	Codice	U.M.	 Descrizione	 Description	 Designation	 Benennung	 Descripción
RG3	RG000300	NR	RACCORDO CORPO A GOMITO 20S MASCHIO-FEMMINA DKOS	20S BODY FITTING ELBOW MALE-FEMALE DKOS	RACCORD À GENOUILLE 20S MÂLE-FEMELLE DKOS	WINKELSTÜCK 20S STIFT- BUCHSE DKOS	UNIÓN EN CODO 20S MACHO- HEMBRA DKOS
RG4	RG000400	NR	RACCORDO CORPO A GOMITO 28L MASCHIO-FEMMINA DKOL	28L BODY FITTING ELBOW MALE-FEMALE DKOL	RACCORD CORPS À GENOUILLE MÂLE-FEMELLE DKOL	WINKELSTÜCK 28L STIFT- BUCHSE DKOL	UNIÓN EN CODO 28L MACHO- HEMBRA DKOL
RG5	RG000500	NR	RACCORDO A L MASCHIO- FEMMINA 1/8	BODY 90 ° M / F 1/8 "			
RG6	RG000600	NR	ADATTATORE 90° BSPP M-FG 1/4	ADAPTOR	ADAPTATEUR	ADAPTER	ADAPTADOR
RN1	RN000100	NR	RACCORDO CORPO D'ESTREMITA' TENUTA ED 8L * 3/8 GAS *K*	END FITTING WITH SEAL ED 8L * 3/8 GAS * K *	RACCORD CORPS D'EXTRÉMITÉ AVEC JOINT ED 8L * 3/8 GAS *K*	ANSCHLUSSSTÜCK MIT DICHTUNG ED 8L * 3/8 GAS * K *	UNIÓN CON JUNTA ED 8L * 3/8 GAS *K*
RN2	RN000200	NR	RACCORDO CORPO D'ESTREMITA' TENUTA ED 12L * 3/8 GAS *K*	END FITTING WITH SEAL ED 12L * 3/8 GAS * K *	RACCORD CORPS D'EXTRÉMITÉ AVEC JOINT ED12L * 3/8 GAS *K*	ANSCHLUSSSTÜCK MIT DICHTUNG ED 12L * 3/8 GAS * K *	UNIÓN CON JUNTA ED 12L * 3/8 GAS *K*
RN3	RN000300	NR	RACCORDO CORPO D'ESTREMITA' TENUTA ED 10L * 3/8 GAS *K*	FITTING END OF BODY 'AND SEAL 10L * 3/8 GAS * K *	RACCORD D'EXTRÉMITÉ AVEC JOINT D'ÉTANCHÉITÉ 10L * 3/8 GAS *K*	ANSCHLUSS	CONEXION
RN4	RN000400	NR	RACCORDO CORPO D'ESTREMITA' TENUTA ED 8L * 1/4 GAS *K*	END FITTING WITH SEAL ED 8L * 1/4 GAS * K *	RACCORD CORPS D'EXTRÉMITÉ AVEC JOINT ED 8L * 1/4 GAS *K*	ANSCHLUSSSTÜCK MIT DICHTUNG ED 8L * 1/4 GAS * K *	UNIÓN CON JUNTA ED 8L * 1/4 GAS *K*
RN5	RN000500	NR	RACCORDO CORPO D'ESTREMITA' TENUTA ED 10L * 1/4 GAS *K*	FITTING END OF BODY 'AND SEAL 10L * 1/4 GAS * K *	RACCORD D'EXTRÉMITÉ AVEC JOINT D'ÉTANCHÉITÉ 10L * 1/4 GAS *K*	ANSCHLUSS	CONEXION
RN6	RN000600	NR	RACCORDO CORPO D'ESTREMITA' TENUTA ED 12L * 1/4 GAS	FITTING END OF BODY 'AND SEAL 12L * 1/4 GAS	RACCORD	ANSCHLUSS	CONEXION
RN7	RN000700	NR	RACCORDO NIPLES GAS CON.- GAS CON. 1/4" * 1/4"	FITTING	RACCORD	ANSCHLUSS	RACORD
RN8	RN000800	NR	RACCORDO CORPO D'ESTREMITA' TENUTA ED 15L * 1/2 GAS *K*	END FITTING WITH SEAL ED 15L * 1/2 * K * GAS	RACCORD CORPS D'EXTRÉMITÉ AVEC JOINT ED 15L * 1/2 GAS *K*	ANSCHLUSSSTÜCK MIT DICHTUNG ED 15L * 1/2 GAS *K*	UNIÓN CON JUNTA ED 15L * 1/2 GAS *K*

POS	Codice	U.M.	 Descrizione	 Description	 Designation	 Benennung	 Descripción
RN9	RN000900	NR	RACCORDO CORPO D'ESTREMITA' TENUTA ED 10L * 1/2 GAS *K*	FITTING END OF BODY 'AND SEAL 10L * 1/2 * K * GAS	RACCORD	ANSCHLUSS	CONEXION
RN10	RN001000	NR	RACCORDO CORPO D'ESTREMITA' TENUTA ED 15L * 3/4 GAS *K*	END FITTING WITH SEAL ED 15L * 3/4 GAS * K *	RACCORD CORPS D'EXTRÉMITÉ AVEC JOINT ED 15L * 3/4 GAS * K *	ANSCHLUSSSTÜCK MIT DICHTUNG ED 15L * 3/4 GAS *K*	UNIÓN CON JUNTA ED 15L * 3/4 GAS *K*
RN11	RN001100	NR	RACCORDO CORPO D'ESTREMITA' TENUTA ED 12L * 1/2 GAS *K*	END FITTING WITH SEAL ED 12L * 1/2 GAS * K *	RACCORD CORPS D'EXTRÉMITÉ AVEC JOINT ED 12L * 1/2 GAS *K*	ANSCHLUSSSTÜCK MIT DICHTUNG ED 12L * 1/2 GAS *K*	UNIÓN CON JUNTA ED 12L * 1/2 GAS *K*
RN12	RN001200	NR	RACCORDO CORPO D'ESTR. TENUTA ED 8L * 1/2 GAS	END FITTING WITH SEAL ED 8L * 1/2 GAS	RACCORD CORP D'EXTRÉMITÉ AVEC JOINT ED 8L * 1/2 GAS	ANSCHLUSSSTÜCK MIT DICHTUNG ED 8L * 1/2 GAS	UNIÓN CON JUNTA ED 8L * 1/2 GAS
RN13	RN001300	NR	RACCORDO CORPO D'ESTR. TENUTA ED 8L * 3/4 GAS	CONNECTOR BODY OF EXTR. SEAL AND 8L * 3/4 GAS	RACCORD	ANSCHLUSS	CONEXION
RN14	RN001400	NR	RACCORDO CORPO D'ESTR. TENUTA ED 12L * 3/4 GAS	CONNECTOR BODY OF EXTR. SEAL AND 12L * 3/4 GAS	RACCORD	ANSCHLUSS	CONEXION
RN15	RN001500	NR	RACCORDO CORPO D'ESTR.TENUTA ED 15L * 3/8 GAS	END FITTING WITH SEAL ED 15L * 3/8 GAS	RACCORD CORPS D'EXTRÉMITÉ AVEC JOINT ED 15L * 3/8 GAS	ANSCHLUSSSTÜCK MIT DICHTUNG ED 15L * 3/8 GAS	UNIÓN CON JUNTA ED 15L * 3/8 GAS
RN16	RN001600	NR	RACCORDO CORPO D'ESTR.TENUTA ED 22L * 3/4 GAS	END FITTING WITH SEAL ED 22L * 3/4 GAS	RACCORD CORP D'EXTRÉMITÉ AVEC JOINT ED 22L * 3/4 GAS	ANSCHLUSSSTÜCK MIT DICHTUNG ED 22L * 3/4 GAS	UNIÓN CON JUNTA ED 22L * 3/4 GAS
RN17	RN001700	NR	RACCORDO CORPO D'ESTR. TENUTA ED 28L * 3/4" GAS	END FITTING WITH SEAL ED 28L * 3/4 BSP	RACCORD CORPS D'EXTRÉMITÉ AVEC JOINT ED 28L * 3/4 BSP	ANSCHLUSSSTÜCK MIT DICHTUNG ED 28L * 3/4" GAS	UNIÓN CON JUNTA ED 28L * 3/4" GAS
RN18	RN001800	NR	RACCORDO CORPO D'ESTR. TENUTA ED 20S * 3/4 GAS	CONNECTOR BODY OF EXTR. SEAL AND 20S * 3/4 GAS	RACCORD	ANSCHLUSS	CONEXION
RN19	RN001900	NR	RACCORDO CORPO D'ESTREMITA' 8L * M 12X1.5 ED	END FITTING 8L * M 12X1.5 ED	RACCORD CORPS D'EXTRÉMITÉ 8L * M 12X1.5 ED	ANSCHLUSSSTÜCK 8L * M 12X1.5 ED	UNIÓN 8L * M 12X1.5 ED
RN20	RN002000	NR	RACCORDO CORPO D'ESTREMITA' 8L * M 14X1.5 ED	FITTING END OF BODY 'AND 8L * M 14X1.5	RACCORD	ANSCHLUSS	CONEXION

POS	Codice	U.M.	 Descrizione	 Description	 Designation	 Benennung	 Descripción
RN21	RN002100	NR	RACCORDO CORPO D'ESTREMITA' 10L * M 18X1.5 ED	END FITTING 10L * M 18X1.5	RACCORD CORPS D'EXTRÉMITÉ 10L * M 18X1.5 ED	ANSCHLUSSSTÜCK 10L * M 18X1.5 ED	UNIÓN 10L * M 18X1.5 ED
RN22	RN002200	NR	RACCORDO CORPO D'ESTR. TENUTA ED 15L * M 18X1.5	CONNECTOR BODY OF EXTR. SEAL AND 15L * M 18X1.5	RACCORD	ANSCHLUSS	CONEXION
RN23	RN002300	NR	RACCORDO CORPO D'ESTR. TENUTA ED 15L * M 22X1.5	END FITTING WIHT SEAL ED 15L * M 22X1.5	RACCORD CORPS D'EXTRÉMITÉ AVEC JOINT ED 15L * M 22X1.5	ANSCHLUSSSTÜCK MIT DICHTUNG ED 15L * M 22X1.5	UNIÓN CON JUNTA ED 15L * M 22X1.5
RN24	RN002400	NR	RACCORDO CORPO D'ESTR. TENUTA ED 22L * M26X1.5	CONNECTOR BODY OF EXTR. SEAL AND 22L * M26X1.5	RACCORD	ANSCHLUSS	CONEXION
RN25	RN002500	NR	RACCORDO CORPO D'ESTR. TENUTA ED 20S * M27X2	CONNECTOR BODY OF EXTR. SEAL AND 20S * M27X2	RACCORD	ANSCHLUSS	CONEXION
RN26	RN002600	NR	RACCORDO CORPO D'ESTR. 8L * 9/16-18 UNF-2A	END FITTING 8L * 9/16-18 UNF-2A	RACCORD CORPS D'EXTRÉMITÉ 8L * 9/16-18 UNF-2A	ANSCHLUSSSTÜCK 8L * 9/16-18 UNF-2A	UNIÓN 8L * 9/16-18 UNF-2A
RN27	RN002700	NR	RACCORDO CORPO D'ESTR. 12L * 3/4 -16 UNF-2A	END FITTING 12L * 3/4 -16 UNF-2A	RACCORD CORPS D'EXTRÉMITÉ 12L * 3/4 -16 UNF-2A	ANSCHLUSSSTÜCK 12L * 3/4 -16 UNF-2A	UNIÓN 12L * 3/4 -16 UNF-2A
RN28	RN002800	NR	RACCORDO CORPO D'ESTR. 20S * 1.5/16 -12 UN-2A	END FITTING 20S * 1.5/16 -12 UN-2A	RACCORD CORPS D'EXTRÉMITÉ 20S * 1.5/16 -12 UN-2A	ANSCHLUSSSTÜCK 20S * 1.5/16 -12 UN-2A	UNIÓN 20S * 1.5/16 -12 UN-2A
RN29	RN002900	NR	RACCORDO CORPO D'ESTR. TENUTA ED 22L * M26X1.5	END FITTING WITH SEAL ED 22L * M26X1.5	RACCORD CORPS D'EXTRÉMITÉ AVEC JOINT ED 22L * M26X1.5	ANSCHLUSSSTÜCK MIT DICHTUNG ED 22L * M26X1.5	UNIÓN CON JUNTA 22L * M26X1.5
RN30	RN003000	NR	RACCORDO CORPO D'ESTR. TENUTA ED 22L * M26X1.5	END FITTING WITH SEAL ED 22L * M26X1.5	RACCORD CORPS D'EXTRÉMITÉ AVEC JOINT ED 22L * M26X1.5	ANSCHLUSSSTÜCK MIT DICHTUNG ED 22L * M26X1.5	UNIÓN CON JUNTA ED 22L * M26X1.5
RN31	RN003100	NR	RACCORDO CORPO D'ESTREMITA' TENUTA ED 6L * 1/4 GAS *K*	END FITTING WITH SEAL 1/4 BSPP 6L	RACCORD CORPS D'EXTRÉMITÉ AVEC JOINT 1/4 BSPP 6L	ANSCHLUSSSTÜCK MIT DICHTUNG 1/4 BSPP 6L	UNIÓN CON JUNTA 1/4 BSPP 6L
RN32	RN003200	NR	RACCORDO CORPO D'ESTREMITA' TENUTA ED 8L * 3/8 GAS *K*	END FITTING WITH SEAL ED 8L * 3/8 GAS * K *	RACCORD CORPS D'EXTRÉMITÉ AVEC JOINT ED 8L * 3/8 GAS *K*	ANSCHLUSSSTÜCK MIT DICHTUNG ED 8L * 3/8 GAS * K *	UNIÓN CON JUNTA ED 8L * 3/8 GAS *K*

POS	Codice	U.M.	 Descrizione	 Description	 Designation	 Benennung	 Descripción
RN33	RN003300	NR	NIPPLES 1/8" JIS 1/8"GAS	CAP	CAPUCHON	NIPPEL	CAPUCHO
RN34	RN003400	NR	NIPPLES 1/4" JIS 1/4"GAS	CAP	CAPUCHON	NIPPEL	CAPUCHO
RN35	RN003500	NR	NIPPLES 3/8" JIS 1/4"GAS	CAP	CAPUCHON	NIPPEL	CAPUCHO
RN36	RN003600	NR	NIPPLES 3/8" JIS 1/4"GAS	CAP	CAPUCHON	NIPPEL	CAPUCHO
RO1	RO000100	NR	OGIVA PER TUBO Ø=12	OGIVE FOR TUBE Ø = 12	OGIVE POUR TUYAU Ø = 12	OGIVE FÜR ROHR Ø = 12	OJIVA PARA TUBO Ø=12
RR1	RR000100	NR	RONDELLA RAME 1/4	COPPER WASHER 1/4	RONDELLE	SCHEIBE	ARANDELA
RR2	RR000200	NR	RONDELLA BONDED GAS 3/8" *K*	BONDED WASHER GAS 3/8 " * K *	RONDELLE	SCHEIBE	ARANDELA
RR3	RR000300	NR	RONDELLA BONDED METRICA 12 *K*	METRIC BONDED WASHER 12 * K *	RONDELLE BONDED MÉTRIQUE 12 *K*	BONDED UNTERLEGSCHIEBE 12 * K *	ARANDELA BONDED MÉTRICA 12 *K*
RR4	RR000400	NR	RONDELLA BONDED GAS 1/4" *K*	BONDED WASHER GAS 1/4 " * K *	RONDELLE		
RR5	RR000500	NR	RONDELLA BONDED GAS 1/2" *K*	BONDED WASHER GAS 1/2 " * K *	RONDELLE BONDED GAS 1/2" *K*	BONDED UNTERLEGSCHIEBE GAS 1/2" *K*	ARANDELA BONDED GAS 1/2" *K*
RR6	RR000600	NR	RONDELLA RAME 3/8	COPPER WASHER 3/8	RONDELLE	SCHEIBE	ARANDELA
RR7	RR000700	NR	RONDELLA BONDED GAS 1/8" *K*	BONDED WASHER GAS 1/8 " * K *	RONDELLE	SCHEIBE	ARANDELA
RR8	RR000800	NR	RONDELLA BONDED GAS 1" *K*	BONDED WASHER GAS 1 " * K *	RONDELLE BONDED GAS 1" *K*	BONDED UNTERLEGSCHIEBE GAS 1" *K*	ARANDELA BONDED GAS 1" *K*
RR9	RR000900	NR	RONDELLA BONDED GAS 3/4" *K*	BONDED WASHER GAS 3/4 " * K *	RONDELLE BONDED GAS 3/4" *K*	BONDED UNTERLEGSCHIEBE GAS 3/4" *K*	ARANDELA BONDED GAS 3/4" *K*
RR10	RR001000	NR	RONDELLA BONDED GAS 1.1/4"	BONDED WASHER GAS 1.1 / 4 "	RONDELLE	SCHEIBE	ARANDELA
RR11	RR001100	NR	RONDELLA RAME M10	COPPER WASHER M10	RONDELLE	SCHEIBE	ARANDELA
RR12	RR001200	NR	RONDELLA RAME 1/2	COPPER WASHER 1/2	RONDELLE	SCHEIBE	ARANDELA
RR13	RR001300	NR	RONDELLA BONDED M12	BONDED WASHER M12	RONDELLE	SCHEIBE	ARANDELA
RS1	RS000100	NR	COPPIA SEMIFLANGE SAE 6000 3/4"	PAIR 6000 SAE FLANGE HALVES 3/4 "	COUPLE SEMI-BRIDES SAE 6000 3/4"	SAE-HALBFLANSCHEN PAAR 6000 3/4"	PAREJA SEMIBRIDAS SAE 6000 3/4"

POS	Codice	U.M.	 Descrizione	 Description	 Designation	 Benennung	 Descripción
RS2	RS000200	NR	RACC.M 20S(M30X2) - ED M 1"5/16 UNF H=33	FITTING M 20S (M30X2) - ED M 1 "5/16 UNF H = 33	RACCORD M 20S(M30X2) - ED M 1"5/16 UNF H=33	ANSCHLUSSSTÜCK M 20S (M30X2) - ED M 1 "5/16 UNF H = 33	UNIÓN M 20S(M30X2) - ED M 1"5/16 UNF H=33
RS3	RS000300	NR	RIDUZIONE M-F GAS 1" * 1/2"	REDUCING GAS M-F 1 " * 1/2"	RÉDUCTION M-F GAS 1" * 1/2"	REDUKTION M-F GAS 1" * 1/2"	REDUCCIÓN M-F GAS 1" * 1/2"
RS4	RS000400	NR	RACCORDO COLONNETTA M15L - 3/8" GAS H=50	COLUMN CONNECTION M15L - 3/8 "GAS H = 50	RACCORD DOIGT M15L - 3/8 "GAS H = 50	ANSCHLUSS M15L - 3/8 "GAS H = 50	CODO M15L - 3/8" GAS H=50
RS5	RS000500	NR	RACCORDO COLONNETTA M15L - 3/8" GAS H=96	COLUMN CONNECTION M15L - 3/8 "GAS H = 96	RACCORD DOIGT M15L - 3/8" GAS H=96	ANSCHLUSS - 3/8 "GAS H = 96	CODO M15L - 3/8" GAS H=96
RS6	RS000600	NR	CODOLO M1/4" ED X FG 8L (M14X1.5)	FITTING M1 / 4 "X AND FG 8L (M14X1.5)	EMBOUT M1/4" ED X FG 8L (M14X1.5)	SCHAFT M1/4" ED X FG 8L (M14X1.5)	CODO M1/4" ED X FG 8L (M14X1.5)
RS7	RS000700	NR	RIDUZIONE M-F GAS 1" * 1/2"	REDUCING GAS M-F 1 " * 1/2"	RÉDUCTION M-F GAS 1" * 1/2"	REDUZIERUNG GAS M-F 1" * 1/2"	REDUCCIÓN M-F GAS 1" * 1/2"
RS8	RS000800	NR	RACCORDO CODOLO D' ESTR. FEM. DKO 12L*3/8 GAS ED	END FITTING FEM. DKO 12L*3/8 GAS ED	RACCORD FEM. DKO 12L*3/8 GAS ED	ANSCHLUSS FEM. DKO 12L*3/8 GAS ED	CONECTOR FEM. DKO 12L*3/8 GAS ED
RS9	RS000900	NR	MANICOTTO ARIA 1/8-1/8	AIR MANIFOLD 1/8-1/8			
RS10	RS001000	NR	RIDUZIONE M-F GAS 3/8" JIS 1/8" BSPP	REDUCING GAS M-F 3/8" JIS 1/8" BSPP	RÉDUCTION M-F GAS 3/8" JIS 1/8" BSPP	REDUZIERUNG GAS M-F 3/8" JIS 1/8" BSPP	REDUCCIÓN M-F GAS 3/8" JIS 1/8" BSPP
RS11	RS001100	NR	RACCORDO M-M 15L	FITTING M-M 15L			
RS12	RS001200	NR	RACCORDO NIPLES GAS CON.- GAS CON.1/2"1/2"	FITTING 1/2" - 1/2"	RACCORD	ANSCHLUSS	RACORD
RT1	RT000100	NR	TAPPO MASCHIO TE GAS 3/8" SVASATO 60° *K*	SCREW EYE FOR GAS 1/2 "H = 50	BOUCHON	VERSCHLUSS	TAPA
RT2	RT000200	NR	TAPPO MASCHIO ESAGONO INTERNO GAS 1/4" SVASATO 60° *K*	MALE PLUG GAS INTERNAL HEX 1/4 "FLARE 60 ° * K *	BOUCHON MÂLE HEXAGONAL INTÉRIEUR GAS 1/4" ÉVASÉ 60° *K*	ZYLINDRISCHER STOPFEN	TAPÓN MACHO HEXÁGONO INTERNO GAS 1/4" SVASATO 60° *K*
RT3	RT000300	NR	TAPPO MASCHIO TE GAS 1/2" SVASATO 60° *K*	MALE PLUG TE GAS 1/2 "FLARE 60 ° * K *	BOUCHON MÂLE TE GAS 1/2" ÉVASÉ 60° *K*	STECKER TE GAS 1/2 "GESENKT 60 ° * K *	TAPÓN MACHO TE GAS 1/2" ABOCINADO 60° *K*
RT4	RT000400	NR	TAPPO MASCHIO TE GAS 1/4" SVASATO 60° *K*	MALE PLUG TE GAS 1/4 "FLARE 60 ° * K *	BOUCHON	VERSCHLUSS	TAPA
RT5	RT000500	NR	TAPPO MASCHIO ESAGONO INTERNO GAS 3/8" SVASATO 60° *K*	MALE PLUG GAS INTERNAL HEX 3/8 "FLARE 60 ° * K *	BOUCHON	VERSCHLUSS	TAPA

POS	Codice	U.M.	 Descrizione	 Description	 Designation	 Benennung	 Descripción
RT6	RT000600	NR	TAPPO MASCHIO ESAGONO INTERNO GAS 1" SVASATO 60° *K*	MALE PLUG GAS INTERNAL HEX 1 "FLARE 60 ° * K *	BOUCHON MÂLE HEXAGONAL INTÉRIEUR GAS 1" ÉVASÉ 60° *K*	ZYLINDRISCHER STOPFEN + DICHTUNG	TAPÓN MACHO HEXÁGONO INTERNO GAS 1" ABOCINADO 60° *K*
RT7	RT000700	NR	TAPPO MASCHIO TE GAS 1/8" SVASATO 60° *K*	MALE PLUG TE GAS 1/8 "FLARE 60 ° * K *	BOUCHON	VERSCHLUSS	TAPA
RT8	RT000800	NR	TAPPO MASCHIO TE GAS 1/4" JIS	MALE PLUG TE GAS 1/4 " JIS	BOUCHON	VERSCHLUSS	TAPA
RT9	RT000900	NR	TAPPOO FEMMINA COMPLETO 6L	COMPLETE 6L FEMALE CAP			
RT10	RT001000	NR	TAPPOO FEMMINA COMPLETO 8L	COMPLETE 8L FEMALE CAP	COUVERCLE	DECKEL	TAPA
RT11	RT001100	NR	TAPPO CILINDRICO TCEI+GUARNIZIONE GAS CI 5.8 3/4 Z.BIANCA	CYLINDRICAL SOCKET HEAD CAP + SEAL GAS CI 5.8 3/4 Z. WHITE	BOUCHON	VERSCHLUSS	TAPA
RT12	RT001200	NR	TAPPO CILINDRICO TCEI+GUARNIZIONE GAS CI 5.8 1/2 Z.BIANCA	CYLINDRICAL SOCKET HEAD CAP + SEAL GAS CI 5.8 1/2 Z. WHITE	BOUCHON	VERSCHLUSS	TAPA
RV1	RV000100	NR	VITE PER OCCHIO GAS 1/4" H=29 *K*	SCREW EYE FOR GAS 1/4 "H = 29 * K *	VIS	SCHRAUBE	TORNILLO
RV2	RV000200	NR	VITE PER OCCHIO DOPPIA GAS 3/8"	SCREW EYE DOUBLE FOR GAS 3/8 "	VIS	SCHRAUBE	TORNILLO
RV3	RV000300	NR	VITE PER OCCHIO GAS 1/2" H=50	SCREW EYE FOR GAS 1/2 "H = 50	VIS	SCHRAUBE	TORNILLO
RV4	RV000400	NR	VITE PER OCCHIO DOPPIA GAS 1/4"	DOUBLE EYE SCREW FOR GAS 1/4"	VIS DOUBLE À OEIL GAS 1/4"	DOPPEL-AUGENSCHRAUBE GAS 1/4"	TORNILLO DOBLE OJO GAS 1/4"
RV5	RV000500	NR	VITE PER OCCHIO GAS 3/8"	SCREW EYE FOR GAS 3/8"	VIS	SCHRAUBE	TORNILLO
RV6	RV000600	NR	VITE PER OCCHIO GAS 1/8"	SCREW EYE FOR GAS 1/8"	VIS	SCHRAUBE	TORNILLO

