



Illustrated Parts Manual

Models
R1532i
R1932
R1932i

PVC
2210

P/N
31220674
March 1, 2023 - Rev B

ANSI

CE



**UK
CA**

AS/NZS



An Oshkosh Corporation Company

REVISION LOG

October 10, 2022 - A - Original Issue of Manual (Edited to 1001250332 Rev O, 1001250333 Rev Y, 1001255009 Rev E & 1001284887 Rev A)

March 1, 2023 - B - Revised Manual (Edited to 1001250332 Rev T, 1001250333 Rev AI, 1001255009 Rev E & 1001284887 Rev A)

GENERAL INFORMATION



1) MACHINE IDENTIFICATION

Machines are identified by model and in some cases a combination of models, serial number (SN) or regional standard (i.e ANSI, CE, CSA). Components may also be identified by SN or manufacturer. Common components that may be identified by these characteristics are engines and hydraulic components.

2) PARTS MANUAL ORGANIZATION

Product information in this manual is organized under section titles. Frame, Cylinder, Hydraulic and Electrical are a few examples. Each section is organized by figure and page number. The information within the Figure is then organized by item number, part number, description and corresponding illustration (s).

3) TABLE OF CONTENTS (NOT SHOWN)

A table of contents is found toward the beginning of the manual. Figure number, description and page number are provided for quick reference to the page containing the related information.

4) RECOMMENDED SPARE PARTS (NOT SHOWN)

The Recommended Spare Parts List, located near the end of the manual, reference most frequently used maintenance parts.

5) PART NUMBER INDEX (NOT SHOWN)

A numerical index listing all part numbers and the corresponding page number(s) appears at the back of the manual.

GENERAL INFORMATION

6) NON-SERVICED PARTS

In some instances, it is necessary to display non-serviced parts, assemblies or installations. In the case of assemblies and installations there will be a Ref in the Qty. column. In case of parts that are not available for service within assemblies or components, there will be a NSS (Not Sold Separately) or NLA (No Longer Available) listed in the Qty. column of the manual.

7) PARTS LIST ITEM NUMBERS

Numbers shown in the item# column correspond to numbers used in the associated illustration (s). Item numbers which are missing from the sequence in the parts list are not used on that page.

8) INDENTED PARTS DESCRIPTION

An indented part description is included in the item under which it is indented.

9) ABBREVIATION AND SYMBOLS

AC.....	Alternating Current	L.....	Liter
ADE.....	Advanced Design Electronics	LB(LBS).....	Pounds
AG.....	Agricultural	LCD.....	Liquid Crystal Display
ANSI.....	American National Standards Institute	LED.....	Light Emitting Diodes
AR.....	As Required	LH.....	Left Hand
ASSY.....	Assembly	LRC.....	Low Rated Countries
AUS.....	Australia	LSS.....	Load Sensing System
AUX.....	Auxiliary	M(m).....	Metric/Meter
AWG.....	American Wire Gauge	MM(mm).....	Milimeter
B/M.....	Bill of Material	mA.....	Miliamps
CAC.....	Charge Air Cooler	NLA.....	No Longer Available
CE.....	European Conformity	NPT.....	National Pipe Threads
CCW.....	Counter Clockwise	NSS.....	Not Sold Separately
CM.....	Centimeter	OD.....	Outside Diameter
CW.....	Clockwise	ORB.....	O-Ring Boss
CSA.....	Canadian Standards Association	ORFS.....	O-Ring Face Seal
CYL.....	Cylinder	OZ (oz).....	Ounces
DIA.....	Diameter	PG.....	Page
DC.....	Direct Current	PN.....	Part Number
DEF.....	Diesel Exhaust Fluid	QT(qt.).....	Quarts
EMS.....	Emergency Stop	QTY.....	Quantity
ENG.....	Engine	REF.....	Reference
FT(ft).....	Feet	REV.....	Revision Level
GA(Ga).....	Gauge	RH.....	Right Hand
HRC.....	High Rated Countries	SAE.....	Society of Automotive Engineers
HVAC.....	Heating, Ventilating, and Air Conditioning	SN.....	Serial Number
HYD.....	Hydraulic	SPEC(S).....	Specifications
Hz.....	Hertz	T/T.....	Turntable
ID.....	Inside Diameter	UGM.....	Universal Ground Module
IN.....	inches	V.....	Volts
ISO.....	International Organization for Standards	W.....	Watts
JIC.....	Joint Industry Council	#.....	Number
KG.....	Kilogram		

10) ILLUSTRATION REFERENCE LETTERS

When necessary, illustrations may contain reference letters that are intended to track information (i. e. hoses, harnesses) from one point to another or to track visual enlargement of components to show details that may be located in another area on the illustration.

Note: Due to continuous product improvements, JLG Industries, Inc. reserves the right to make specification changes without prior notification. Contact JLG Industries, Inc. for updated information.

TABLE OF CONTENTS

SECTION 1 - FRAME.....	13
FIGURE 1-1. STEER INSTALLATION (MACHINES WITH SN STARTING WITH M2)	14
FIGURE 1-2. STEER INSTALLATION (MACHINES WITH SN STARTING WITH B2).....	16
FIGURE 1-3. STEER INSTALLATION (MACHINES WITH SN STARTING WITH G2)	18
FIGURE 1-4. STEER SPINDLE COVER INSTALLATION (MACHINES WITH SN STARTING WITH M2)	20
FIGURE 1-5. STEER SPINDLE COVER INSTALLATION (MACHINES WITH SN STARTING WITH B2).....	22
FIGURE 1-6. DRIVE/BRAKE INSTALLATION (MACHINES WITH SN STARTING WITH B2, M2 & G2).....	24
FIGURE 1-7. DRIVE MOTOR ASSEMBLY (MACHINES WITH SN STARTING WITH B2, M2 & G2).....	26
FIGURE 1-8. TIRE AND WHEEL INSTALLATION	28
FIGURE 1-9. WHEEL INSTALLATION (MACHINES WITH SN STARTING WITH G2).....	30
FIGURE 1-10. POTHOLE PROTECTION SYSTEM INSTALLATION	32
FIGURE 1-11. POTHOLE PROTECTION SYSTEM INSTALLATION (MACHINES WITH SN STARTING WITH G2)	34
FIGURE 1-12. TILT SENSOR INSTALLATION	36
FIGURE 1-13. BATTERY CHARGER INSTALLATION - DELTA-Q (WITHOUT COMMUNICATION PORT) (LOCALLY SUPPLIED PLUG).....	38
FIGURE 1-14. BATTERY CHARGER INSTALLATION - DELTA-Q (WITH COMMUNICATION PORT) (LOCALLY SUPPLIED PLUG).....	40
FIGURE 1-15. BATTERY CHARGER INSTALLATION - DELTA-Q (WITHOUT COMMUNICATION PORT) (110V PLUG) (R1532I)	42
FIGURE 1-16. BATTERY CHARGER INSTALLATION - DELTA-Q (WITH COMMUNICATION PORT) (110V PLUG) (R1532I) ...	44
FIGURE 1-17. BATTERY CHARGER INSTALLATION - DELTA-Q (WITHOUT COMMUNICATION PORT) (KOREAN PLUG) (R1532I).....	46
FIGURE 1-18. BATTERY CHARGER INSTALLATION - DELTA-Q (WITH COMMUNICATION PORT) (KOREAN PLUG) (R1532I)	48
FIGURE 1-19. BATTERY CHARGER INSTALLATION - GREEN POWER (CHINA PLUG) (MACHINES WITH SN STARTING WITH B2) (R1532I).....	50
FIGURE 1-20. BATTERY CHARGER INSTALLATION - EAGLE PERFORMANCE (110V PLUG) (MACHINES WITH SN STARTING WITH M2) (R1532I)	52
FIGURE 1-21. BATTERY CHARGER INSTALLATION - GREEN POWER (LOCALLY SUPPLIED PLUG) (MACHINES WITH SN STARTING WITH B2) (R1532I)	54
FIGURE 1-22. BATTERY CHARGER INSTALLATION - DELTA-Q (WITHOUT COMMUNICATION PORT) (R1932I/R1932)	56
FIGURE 1-23. BATTERY CHARGER INSTALLATION - DELTA-Q (WITHOUT COMMUNICATION PORT) (R1932I/R1932)	58
FIGURE 1-24. BATTERY CHARGER INSTALLATION - EAGLE PERFORMANCE (MACHINES WITH SN STARTING WITH M2) (R1932I/R1932)	60
FIGURE 1-25. BATTERY CHARGER INSTALLATION - GREEN POWER (LOCALLY SUPPLIED PLUG) (MACHINES WITH SN STARTING WITH B2 & G2) (R1932I/R1932)	62
FIGURE 1-26. STROBE LIGHT INSTALLATION - SINGLE SANMAK BRAND (AMBER) (WITH GUARD)	64
FIGURE 1-27. STROBE LIGHT INSTALLATION - DUAL SANMAK BRAND (AMBER) (WITH GUARD).....	66
FIGURE 1-28. ALARM INSTALLATION (AMBIENT/WHITE NOISE) (OPTIONAL)	68
FIGURE 1-29. LADDER INSTALLATION	70
FIGURE 1-30. FRAME COVERS INSTALLATION - FRONT AND REAR (R1532I/R1932I).....	72
FIGURE 1-31. FRAME COVERS INSTALLATION - FRONT (R1932).....	74
SECTION 2 - GROUND CONTROLS	77
FIGURE 2-1. HYDRAULIC COMPONENTS INSTALLATION (WITH CONCENTRIC PUMP/MOTOR)	78
FIGURE 2-2. HYDRAULIC COMPONENTS INSTALLATION (WITH BUCHER PUMP/MOTOR)	80
FIGURE 2-3. VALVE ASSEMBLY - REXROTH (USED WITH CONCENTRIC PUMP/MOTOR).....	82
FIGURE 2-4. VALVE ASSEMBLY - STANT (USED WITH BUCHER PUMP/MOTOR)	84

TABLE OF CONTENTS

FIGURE 2-5. ELECTRICAL COMPONENTS INSTALLATION (MACHINES WITH SN STARTING WITH B2 & M2)	86
FIGURE 2-6. ELECTRICAL COMPONENTS INSTALLATION (MACHINES WITH SN STARTING WITH 12)	88
FIGURE 2-7. ELECTRICAL COMPONENTS INSTALLATION (MACHINES WITH SN STARTING WITH G2)	90
FIGURE 2-8. MDI INSTALLATION.....	92
FIGURE 2-9. BATTERIES INSTALLATION - STANDARD BATTERIES WITH DISCONNECT	94
FIGURE 2-10. BATTERIES INSTALLATION - AGM BATTERIES WITH DISCONNECT (MACHINES WITH SN STARTING WITH M2).....	96
FIGURE 2-11. BATTERIES INSTALLATION - AGM EVCG BATTERIES WITH DISCONNECT (MACHINES WITH SN STARTING WITH 12, B2 & G2)	98
FIGURE 2-12. BATTERIES INSTALLATION - TROJAN BATTERIES WITH DISCONNECT (MACHINES WITH SN STARTING WITH B2 & G2)	100
FIGURE 2-13. INVERTER INSTALLATION (OPTIONAL) (MACHINES WITH SN STARTING WITH M2)	102
FIGURE 2-14. DOORS INSTALLATION (MACHINES WITH SN STARTING WITH B2, & M2)	104
FIGURE 2-15. DOORS INSTALLATION (MACHINES WITH SN STARTING WITH G2).....	106
SECTION 3 - SCISSORS ARMS.....	109
FIGURE 3-1. SCISSORS ARMS INSTALLATION – R1532I (CHINA, KOREAN, CE & UK CA SPECS).....	110
FIGURE 3-2. SCISSORS ARMS INSTALLATION – R1532I (ANSI, ANSI EXPORT AND CSA SPECS) (Prior to SN B200076287)	114
FIGURE 3-3. SCISSORS ARMS INSTALLATION – R1532I (ANSI, ANSI EXPORT AND CSA SPECS) (SN B200076287 to Present).....	118
FIGURE 3-4. SCISSORS ARMS INSTALLATION – R1532I (ANSI, ANSI EXPORT AND CSA SPECS) (SN B200076287 to Present).....	120
FIGURE 3-5. SCISSORS ARMS INSTALLATION – R1932/R1932I (MACHINES WITH SN STARTING WITH M2) (Prior to SN M200060339)	124
FIGURE 3-6. SCISSORS ARMS INSTALLATION – R1932/R1932I (MACHINES WITH SN STARTING WITH B2)	128
FIGURE 3-7. SCISSORS ARMS INSTALLATION - R1932/R1932I (MACHINES WITH SN STARTING WITH G2).....	132
FIGURE 3-8. SCISSORS ARMS INSTALLATION - R1932/R1932I (MACHINES WITH SN STARTING WITH M2) (SN M200060339 to Present).....	136
FIGURE 3-9. SCISSORS ARMS INSTALLATION - R1932/R1932I (MACHINES WITH SN STARTING WITH M2) (SN M200060339 to Present).....	138
FIGURE 3-10. SCISSORS ARMS KIT - R1532I	142
FIGURE 3-11. SCISSORS ARMS KIT - R1932/R1932I.....	144
FIGURE 3-12. ARM GUARD INSTALLATION	146
SECTION 4 - PLATFORM.....	149
FIGURE 4-1. PLATFORM INSTALLATION - R1532I.....	150
FIGURE 4-2. PLATFORM INSTALLATION - R1932/R1932I	152
FIGURE 4-3. PLATFORM INSTALLATION (MACHINES WITH SN STARTING WITH G2)	154
FIGURE 4-4. PLATFORM EXTENSION INSTALLATION	156
FIGURE 4-5. RAILS INSTALLATION - FIXED RAILS/GATE ENTRY (INSIDE TUBE SLIDER)	158
FIGURE 4-6. RAIL KIT - FIXED RAILS (INSIDE TUBE SLIDER)	160
FIGURE 4-7. RAILS INSTALLATION - FOLD-DOWN RAILS/GATE ENTRY (INSIDE TUBE SLIDER).....	162
FIGURE 4-8. RAIL KIT - FOLD-DOWN RAILS (INSIDE TUBE SLIDER).....	164
FIGURE 4-9. RAILS INSTALLATION - FOLD-DOWN RAILS/GATE ENTRY (QUIK FOLD) (INSIDE TUBE SLIDER) (ALL SPECS EXCEPT AUSTRALIAN, CE, KOREAN & UK CA SPECS).....	166
FIGURE 4-10. RAILS INSTALLATION - FOLD-DOWN RAILS/GATE ENTRY (QUIK FOLD) (INSIDE TUBE SLIDER) (CE & UK CA SPECS).....	168
FIGURE 4-11. RAILS INSTALLATION - FOLD-DOWN RAILS/GATE ENTRY (OUTSIDE TUBE SLIDER) (ANSI EXPORT AND CHINA SPECS).....	172

TABLE OF CONTENTS

FIGURE 4-12. RAILS INSTALLATION - FOLD-DOWN RAILS/GATE ENTRY (OUTSIDE TUBE SLIDER) (KOREA SPECS)	174
FIGURE 4-13. RAILS INSTALLATION - FOLD-DOWN RAILS/GATE ENTRY (NARROW ACCESS).....	176
FIGURE 4-14. HANDLE EXTENSION INSTALLATION (OPTIONAL)	180
FIGURE 4-15. GATE LATCH INSTALLATION - OPTIONAL.....	182
FIGURE 4-16. PLATFORM CONTROL BOX INSTALLATION (MACHINES WITH SN STARTING WITH G2, B2, AND M2).....	184
FIGURE 4-17. PLATFORM CONTROL BOX INSTALLATION (MACHINES WITH SN STARTING WITH G2) (CHINA & ANSI EXPORT SPEC).....	186
FIGURE 4-18. PLATFORM CONTROL BOX INSTALLATION (MACHINES WITH SN STARTING WITH G2) (ANSI EXPORT SPEC ONLY).....	188
FIGURE 4-19. PLATFORM CONTROL PLUG INSTALLATION.....	190
FIGURE 4-20. DRIVE/STEER CONTROLLER ASSEMBLY	192
FIGURE 4-21. USB/PHONE CRADLE INSTALLATION.....	194
FIGURE 4-22. OVERHEAD PROTECTION INSTALLATION (KOREAN SPECS)	196
FIGURE 4-23. PANEL CARRIER INSTALLATION (R1932).....	198
FIGURE 4-24. PIPE RACK INSTALLATION (R1932).....	200
FIGURE 4-25. ELECTRICIANS TREE ACCESSORY	202
FIGURE 4-26. WORKSTATION ACCESSORY	204
FIGURE 4-27. WORKSTATION INSTALLATION.....	206
FIGURE 4-28. ELECTRICIAN TREE INSTALLATION	208
FIGURE 4-29. WORKLIGHT INSTALLATION.....	210
FIGURE 4-30. FIRE EXTINGUISHER INSTALLATION.....	212
SECTION 5 - CYLINDER.....	215
FIGURE 5-1. LIFT CYLINDER ASSEMBLY (MACHINES WITH SN STARTING WITH B2 & M2).....	216
FIGURE 5-2. LIFT CYLINDER ASSEMBLY (MACHINES WITH SN STARTING WITH B2 & M2).....	218
FIGURE 5-3. LIFT CYLINDER ASSEMBLY (MACHINES WITH SN STARTING WITH G2).....	220
FIGURE 5-4. STEER CYLINDER ASSEMBLY (MACHINES WITH SN STARTING WITH M2)	222
FIGURE 5-5. STEER CYLINDER ASSEMBLY (MACHINES WITH SN STARTING WITH B2).....	224
FIGURE 5-6. STEER CYLINDER ASSEMBLY (MACHINES WITH SN STARTING WITH G2)	226
SECTION 6 - HYDRAULIC	229
FIGURE 6-1. HYDRAULIC DIAGRAM.....	230
FIGURE 6-2. HYDRAULIC DIAGRAM (WITH BUCHER PUMP/MOTOR)	232
SECTION 7 - ELECTRICAL.....	235
FIGURE 7-1. AC BOX AT PLATFORM INSTALLATION - 110V GFI (ANSI, ANSI EXPORT, CHINA, CSA, JAPANESE AND KOREA SPECS).....	236
FIGURE 7-2. AC BOX AT PLATFORM INSTALLATION - 110V IEC YELLOW (CE & UK CA SPECS).....	238
FIGURE 7-3. AC BOX AT PLATFORM INSTALLATION - 220V IEC BLUE (CE & UK CA SPECS)	240
FIGURE 7-4. AC BOX AT PLATFORM INSTALLATION - 220V CEE7 POST GROUND (CE & UK CA SPECS).....	242
FIGURE 7-5. AC BOX AT PLATFORM INSTALLATION - 220V CEE7 SIDE GROUND (CE & UK CA SPECS)	244
FIGURE 7-6. AC BOX AT PLATFORM INSTALLATION - 220V AFSINT 107 (CE & UK CA SPECS)	246
FIGURE 7-7. AC BOX AT PLATFORM INSTALLATION - 220V CHINA PLUG (CHINA SPECS)	248
FIGURE 7-8. AC BOX AT PLATFORM INSTALLATION - 220V LOCALLY SUPPLIED COMPONENTS (ALL SPECS)	250
FIGURE 7-9. BREAKER BOX KIT WITH 1 DOUBLE BREAKER.....	252
FIGURE 7-10. BREAKER BOX KIT WITH 3 BREAKERS	254
FIGURE 7-11. CHARGER HARNESS (CHARGER WITH COMMUNICATION PORT).....	256

TABLE OF CONTENTS

FIGURE 7-12. CHARGER PLUG INSTALLATION - LOCALLY SUPPLIED PLUG (ALL SPECS) (R1932I/R1932).....	258
FIGURE 7-13. CHARGER PLUG INSTALLATION - 110V PLUG (ALL SPECS EXCEPT AUSTRALIAN, CE, KOREA & UK CA SPECS) (R1932I/R1932)	260
FIGURE 7-14. CHARGER PLUG INSTALLATION (AUSTRALIAN PLUG) (R1932I/R1932).....	262
FIGURE 7-15. CHARGER PLUG INSTALLATION - 220V AFSINT 107 (CE & UK CA SPEC) (R1932I/R1932).....	264
FIGURE 7-16. CHARGER PLUG INSTALLATION - 220V CEE7 PLUG (CE & UK CA SPECS) (R1932I/R1932).....	266
FIGURE 7-17. CHARGER PLUG INSTALLATION - 110V IEC YELLOW (CE & UK CA SPEC) (R1932I/R1932)	268
FIGURE 7-18. CHARGER PLUG INSTALLATION - 220V IEC BLUE (CE & UK CA SPEC) (R1932I/R1932).....	270
FIGURE 7-19. CHARGER PLUG INSTALLATION (CHINA PLUG) (R1932I/R1932).....	272
FIGURE 7-20. CHASSIS HARNESS.....	274
FIGURE 7-21. CLEARSKY INSTALLATION - 3 WIRE (ALL SPECS).....	278
FIGURE 7-22. CLEARSKY INSTALLATION (ANSI & CSA SPECS).....	280
FIGURE 7-23. CLEARSKY INSTALLATION (ANSI EXPORT, CE & UK CA SPECS)	282
FIGURE 7-24. CLEARSKY INSTALLATION (AUSTRALIAN SPECS)	284
FIGURE 7-25. CLEARSKY INSTALLATION (CHINA SPECS)	286
FIGURE 7-26. CLEARSKY HARNESS - 3 WIRE (ALL SPECS).....	288
FIGURE 7-27. CLEARSKY JUMPER HARNESS - 3 WIRE (ALL SPECS)	290
FIGURE 7-28. CLEARSKY HARNESS (ALL SPECS EXCEPT CHINA SPECS).....	292
FIGURE 7-29. CLEARSKY HARNESS (CHINA SPECS).....	294
FIGURE 7-30. CLEARSKY SPLICE HARNESS	296
FIGURE 7-31. GROUND TO PLATFORM CABLE INSTALLATION - R1532I WITHOUT PLATFORM COIL CABLE	298
FIGURE 7-32. GROUND TO PLATFORM CABLE INSTALLATION - R1532I WITH PLATFORM COIL CABLE	300
FIGURE 7-33. GROUND TO PLATFORM CABLE INSTALLATION - R1532I WITHOUT PLATFORM COIL CABLE AND WITH FOOTSWITCH	302
FIGURE 7-34. GROUND TO PLATFORM CABLE INSTALLATION - R1532I WITH PLATFORM COIL CABLE AND FOOTSWITCH.....	304
FIGURE 7-35. GROUND TO PLATFORM CABLE INSTALLATION – R1932I/R1932 WITHOUT PLATFORM COIL CABLE (ALL SPECS EXCEPT AUSTRALIAN AND KOREA SPECS).....	306
FIGURE 7-36. GROUND TO PLATFORM CABLE INSTALLATION - R1932 WITHOUT PLATFORM COIL CABLE (AUSTRALIAN SPECS).....	308
FIGURE 7-37. GROUND TO PLATFORM CABLE INSTALLATION - R1932I/R1932 WITH PLATFORM COIL CABLE (ALL SPECS EXCEPT AUSTRALIAN AND KOREA SPECS AND NOBLE)	310
FIGURE 7-38. GROUND TO PLATFORM CABLE INSTALLATION - R1932 WITH PLATFORM COIL CABLE (AUSTRALIAN SPECS).....	312
FIGURE 7-39. GROUND TO PLATFORM CABLE INSTALLATION - R1932I/R1932 WITHOUT PLATFORM COIL CABLE AND WITH FOOTSWITCH	314
FIGURE 7-40. GROUND TO PLATFORM CABLE INSTALLATION - R1932I/R1932 WITH PLATFORM COIL CABLE AND FOOTSWITCH	316
FIGURE 7-41. GROUND TO PLATFORM CABLE INSTALLATION - R1932I/R1932 WITH PLATFORM STRAIGHT CABLE ONLY (MACHINES WITH SN STARTING WITH 12).....	318
FIGURE 7-42. GROUND TO PLATFORM CABLE INSTALLATION - R1932I/R1932 WITH PLATFORM COIL CABLE ONLY (MACHINES WITH SN STARTING WITH 12).....	320
FIGURE 7-43. GROUND TO PLATFORM CABLE INSTALLATION - R1932 WITHOUT FOOTSWITCH (MACHINES WITH SN STARTING WITH G2).....	322
FIGURE 7-44. GROUND TO PLATFORM CABLE INSTALLATION - R1932 WITH FOOTSWITCH (MACHINES WITH SN STARTING WITH G2).....	324
FIGURE 7-45. JUMPER HARNESS.....	326
FIGURE 7-46. LIFT DOWN HARNESS - WITH LSS.....	328
FIGURE 7-47. LIGHT HARNESS.....	330
FIGURE 7-48. PLATFORM BOX HARNESS (MACHINES WITH SN STARTING WITH 12, B2, AND M2).....	332

TABLE OF CONTENTS

FIGURE 7-49. PLATFORM BOX HARNESS (MACHINES WITH SN STARTING WITH G2) (CHINA AND ANSI EXPORT SPEC)	334
FIGURE 7-50. PLATFORM BOX HARNESS (MACHINES WITH SN STARTING WITH G2) (ANSI EXPORT SPEC ONLY)	336
FIGURE 7-51. PLATFORM HARNESS - R1932 WITH FOOTSWITCH (MACHINES WITH SN STARTING WITH G2)	338
FIGURE 7-52. RECEPTACLE BOX KIT - 110V GFI	340
FIGURE 7-53. RECEPTACLE BOX KIT - 110V IEC YELLOW (CE & UK CA SPEC)	342
FIGURE 7-54. RECEPTACLE BOX KIT - 220V IEC BLUE (CE & UK CA SPEC)	344
FIGURE 7-55. RECEPTACLE BOX KIT - 220V CEE7 POST GROUND (CE & UK CA SPEC)	346
FIGURE 7-56. RECEPTACLE BOX KIT - 220V CEE7 SIDE GROUND (CE & UK CA SPEC)	348
FIGURE 7-57. RECEPTACLE BOX KIT - 220V AFSINT 107 (CE & UK CA SPEC)	350
FIGURE 7-58. WORKLIGHT CABLE	352
SECTION 8 - DECALS	355
FIGURE 8-1. DECAL INSTALLATION (ANSI SPEC)	356
FIGURE 8-2. DECAL INSTALLATION (AUSTRALIAN SPECS)	358
FIGURE 8-3. DECAL INSTALLATION (BRAZIL SPECS)	360
FIGURE 8-4. DECAL INSTALLATION (CE & UK CA SPECS)	362
FIGURE 8-5. DECAL INSTALLATION (CHINA SPECS)	364
FIGURE 8-6. DECAL INSTALLATION (CSA SPECS)	366
FIGURE 8-7. DECAL INSTALLATION (KOREAN SPECS)	368
FIGURE 8-8. DECAL INSTALLATION (LATIN AMERICAN SPECS)	370
FIGURE 8-9. DECAL INSTALLATION - OPTIONS	372
SECTION 9 - RECOMMENDED SERVICE PARTS STOCK	375
FIGURE 9-1. RECOMMENDED SERVICE PARTS STOCK	376
SECTION 10 - SPECIAL OPTIONS/ACCESSORIES/KITS	377
FIGURE 10-1. SPECIAL OPTIONS/ACCESSORIES/KITS	378
PART NUMBER INDEX	381

SECTION 1 - FRAME

SECTION 1 - FRAME

FIGURE 1-1. STEER INSTALLATION (MACHINES WITH SN STARTING WITH M2)

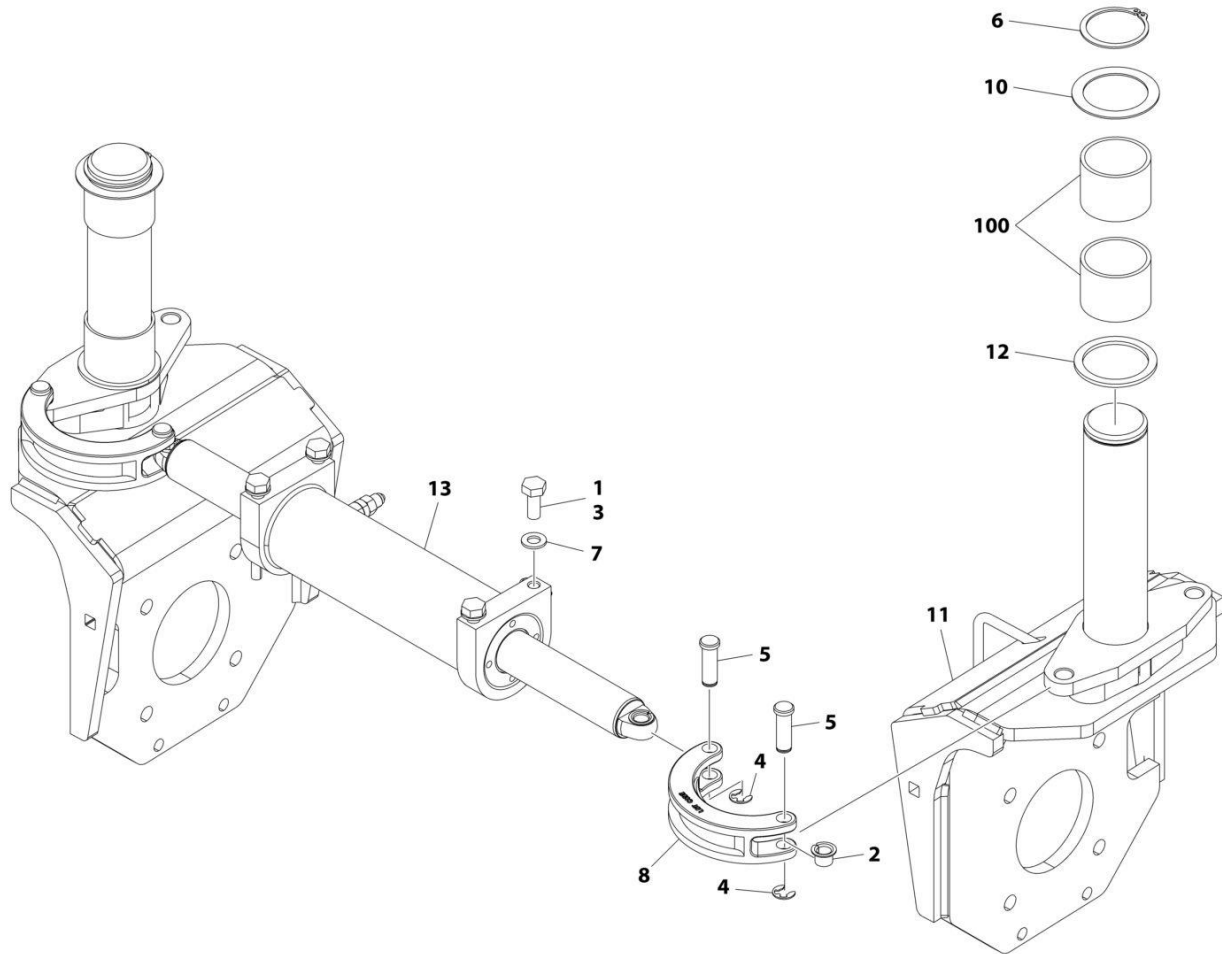

ART_1001202300

SECTION 1 - FRAME

FIGURE 1-1. STEER INSTALLATION (MACHINES WITH SN STARTING WITH M2)

ITEM	PART NUMBER	QTY	DESCRIPTION	REV
	1001202300	Ref	STEER INSTALLATION	E
1	0100011	AR	Compound, Locking	
2	0440259	2	Bearing	
3	0761012	4	Bolt M10 x 25	
4	1380153	4	Clip	
5	3423037	4	Pin	
6	3760217	2	Ring, Retaining	
7	4812000	4	Washer M10	
8	4846757	2	Lug, Steering	
10	1001197396	2	Washer	
11	1001201248	2	Spindle	
12	1001205751	2	Washer	
13	1001220570	1	Steer Cylinder Assembly (See Separate Breakdown in CYLINDER SECTION)	
100	1001153785	4	Bearing (Part of Frame)	

SECTION 1 - FRAME

FIGURE 1-2. STEER INSTALLATION (MACHINES WITH SN STARTING WITH B2)

ITEM	PART NUMBER	QTY	DESCRIPTION	REV
	1001263538	Ref	STEER INSTALLATION	B
1	0100011	AR	Compound, Locking	
2	0440259	2	Bearing	
3	0761012	4	Bolt M10 x 25	
4	1380153	4	Clip	
5	3423037	4	Pin	
6	3760217	2	Ring, Retaining	
7	4812000	4	Washer M10	
8	4846757	2	Lug, Steering	
9	1001197396	2	Washer	
10	1001201248	2	Spindle	
11	1001269507	2	Washer	
12	1001256788	1	Steer Cylinder Assembly (See Separate Breakdown in CYLINDER Section)	
100	1001153785	4	Bearing (Part of Frame)	

SECTION 1 - FRAME

FIGURE 1-3. STEER INSTALLATION (MACHINES WITH SN STARTING WITH G2)

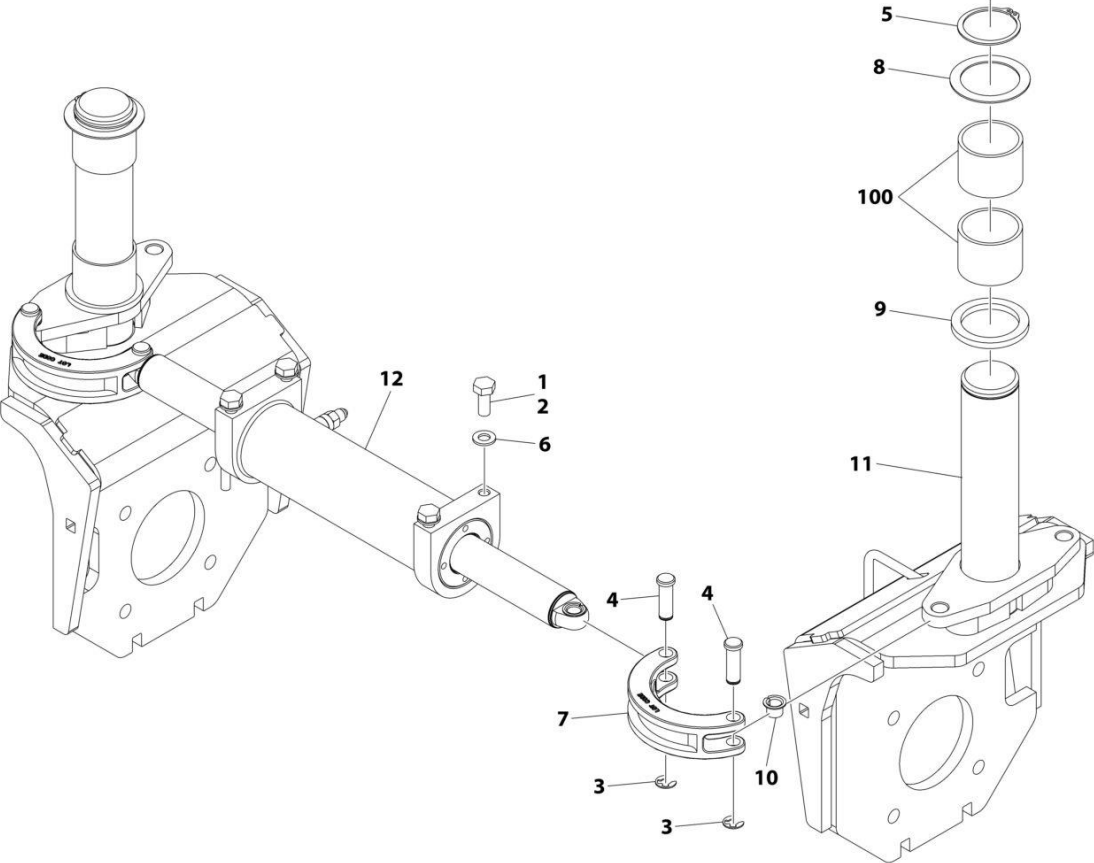

ART_1001276584

SECTION 1 - FRAME

FIGURE 1-3. STEER INSTALLATION (MACHINES WITH SN STARTING WITH G2)

ITEM	PART NUMBER	QTY	DESCRIPTION	REV
	1001276584	Ref	STEER INSTALLATION	A
1	0100011	AR	Compound, Locking	
2	0761012	4	Bolt M10 x 25	
3	1380153	4	Clip	
4	3423037	4	Pin	
5	3760217	2	Ring, Retaining	
6	4812000	4	Washer M10	
7	4846757	2	Lug, Steering	
8	1001197396	2	Washer	
9	1001269507	2	Washer	
10	1001276696	2	Sleeve	
11	1001276699	2	Spindle	
12	1001276701	1	Steer Cylinder Assembly (See Separate Breakdown in CYLINDER Section)	
100	1001153785	4	Bearing (Part of Frame)	

SECTION 1 - FRAME

FIGURE 1-4. STEER SPINDLE COVER INSTALLATION (MACHINES WITH SN STARTING WITH M2)

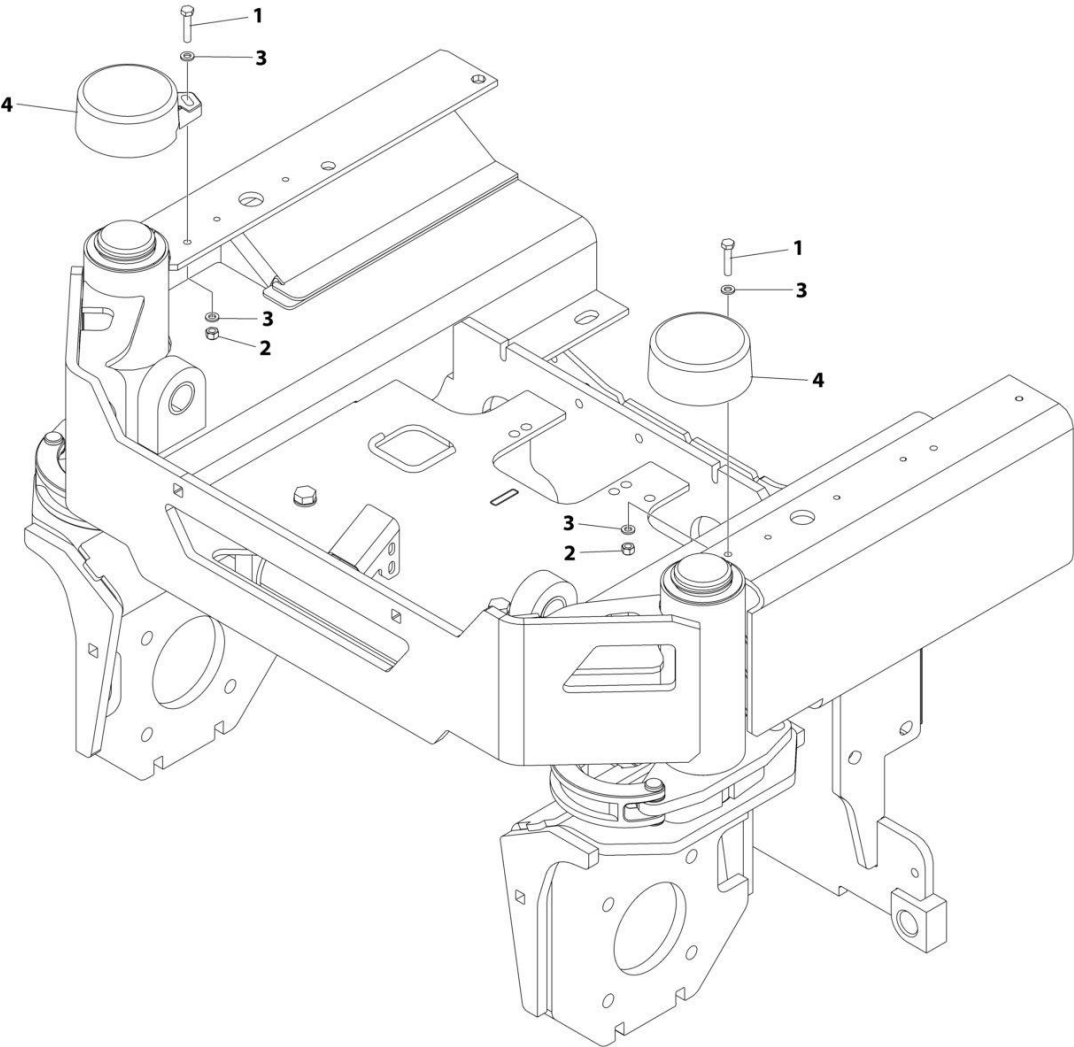

ART_1001269704

SECTION 1 - FRAME

FIGURE 1-4. STEER SPINDLE COVER INSTALLATION (MACHINES WITH SN STARTING WITH M2)

ITEM	PART NUMBER	QTY	DESCRIPTION	REV
	1001269704	Ref	STEER SPINDLE COVER INSTALLATION	A
1	0700614	2	Bolt M6 x 30	
2	3290605	2	Nut M6	
3	4811700	4	Washer M6	
4	1001262464	2	Cover, Steering	

SECTION 1 - FRAME

FIGURE 1-5. STEER SPINDLE COVER INSTALLATION (MACHINES WITH SN STARTING WITH B2)

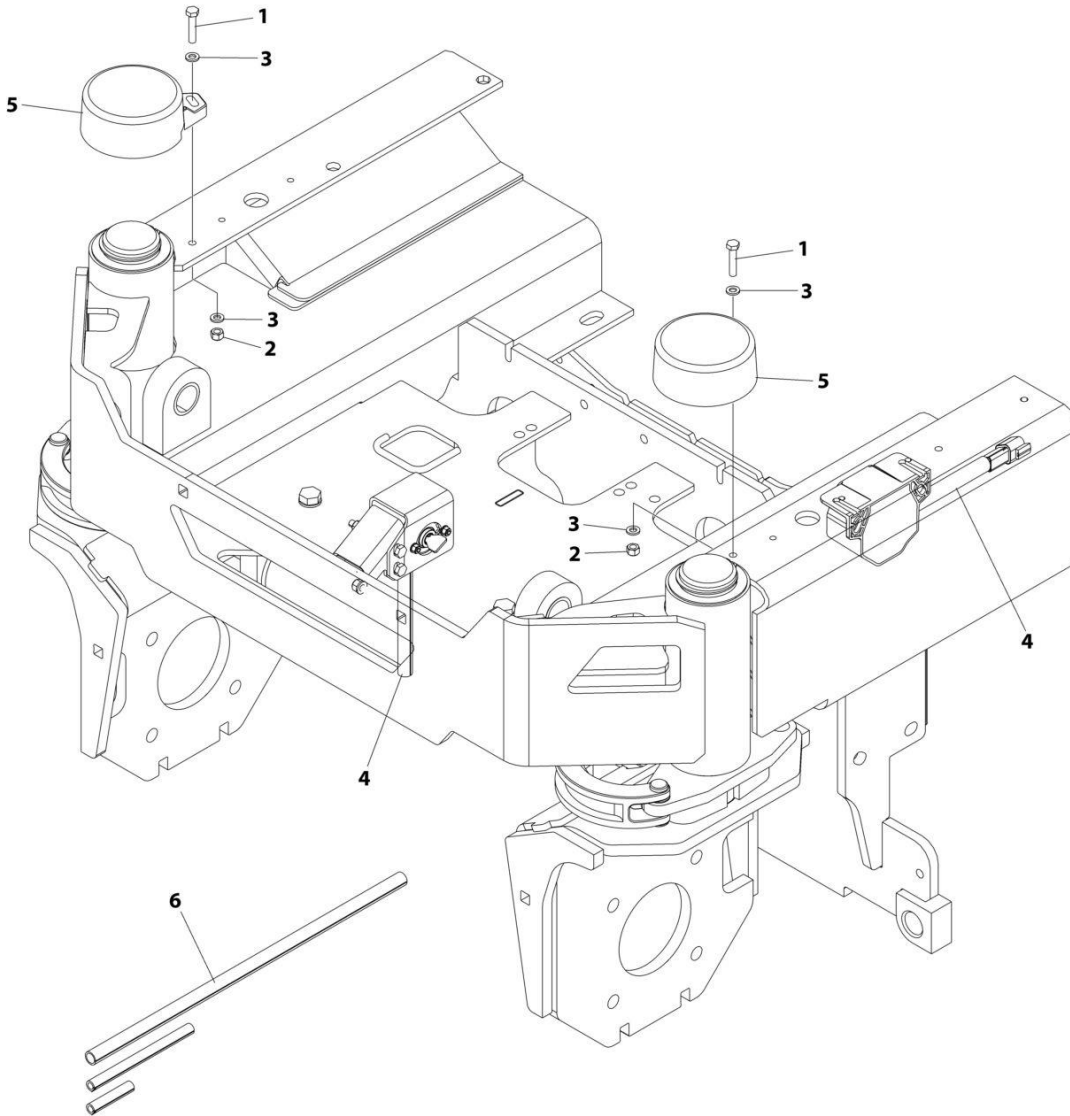

(INSTALLED ON LSS HARNESS)

ART_1001271574

SECTION 1 - FRAME

FIGURE 1-5. STEER SPINDLE COVER INSTALLATION (MACHINES WITH SN STARTING WITH B2)

ITEM	PART NUMBER	QTY	DESCRIPTION	REV
	1001271574	Ref	STEER SPINDLE COVER INSTALLATION	A
1	0700614	2	Bolt M6 x 30	
2	3290605	2	Nut M6	
3	4811700	4	Washer M6	
4	1001262299	2	Conduit	
5	1001262464	2	Cover, Steering	
6	1001270823	1	Conduit	

SECTION 1 - FRAME

FIGURE 1-6. DRIVE/BRAKE INSTALLATION (MACHINES WITH SN STARTING WITH B2, M2 & G2)

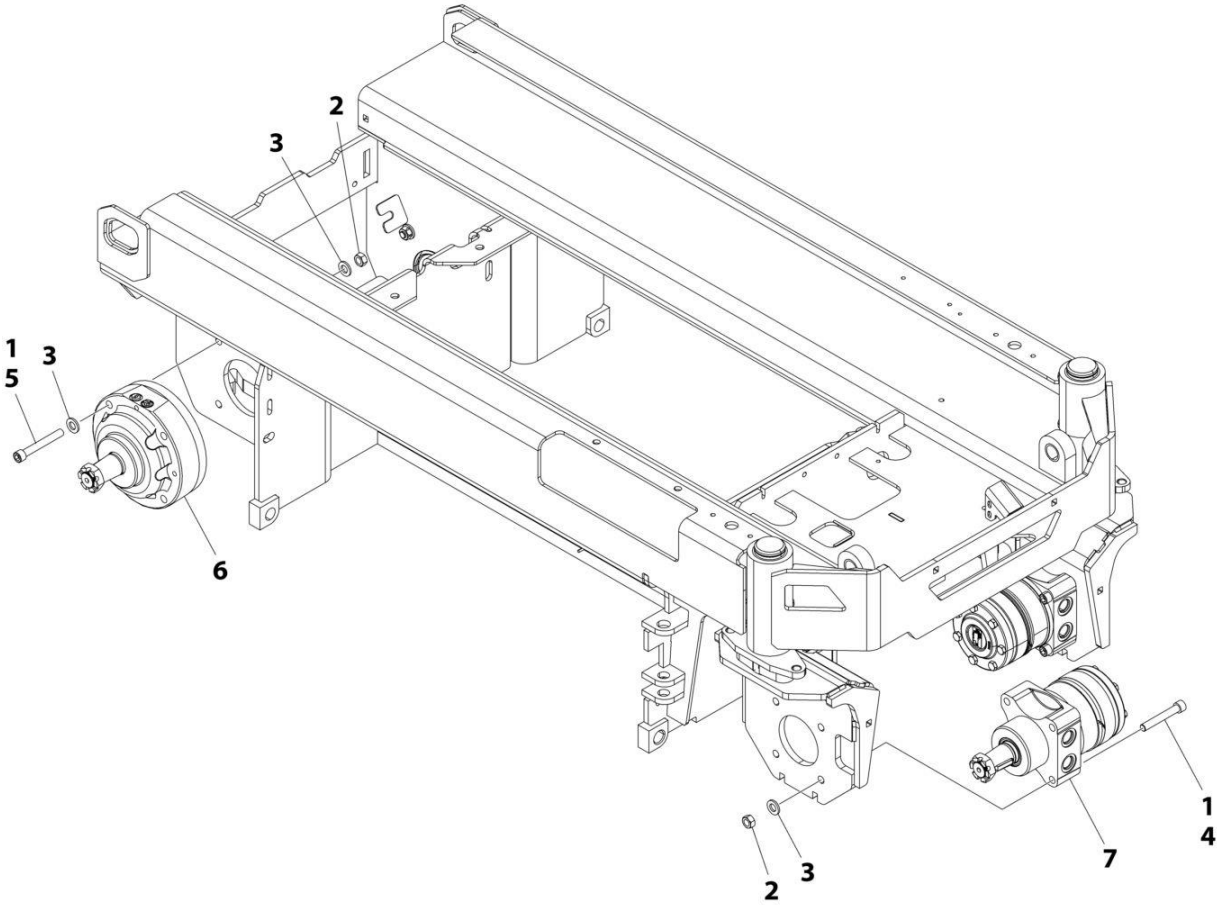

ART_1001290404

SECTION 1 - FRAME

FIGURE 1-6. DRIVE/BRAKE INSTALLATION (MACHINES WITH SN STARTING WITH B2, M2 & G2)

ITEM	PART NUMBER	QTY	DESCRIPTION	REV
	1001290404	Ref	DRIVE/BRAKE INSTALLATION	A
1	0100011	AR	Compound, Locking	
2	3331211	16	Nut M12 Class 10	
3	5241200	24	Washer M12	
4	5272120	8	Capscrew M12 x 80 Class 12.9	
5	5272122	8	Capscrew M12 x 90 Class 12.9	
6	1001202773	2	Drive Brake Assembly (Note: No Internal Service Parts Available)	
6	70005918	1	Key, Shaft	
6	70005919	1	Nut 1-1/8	
7	1001289248	2	Drive Motor Assembly (See Separate Breakdown in this Section)	

SECTION 1 - FRAME

FIGURE 1-7. DRIVE MOTOR ASSEMBLY (MACHINES WITH SN STARTING WITH B2, M2 & G2)

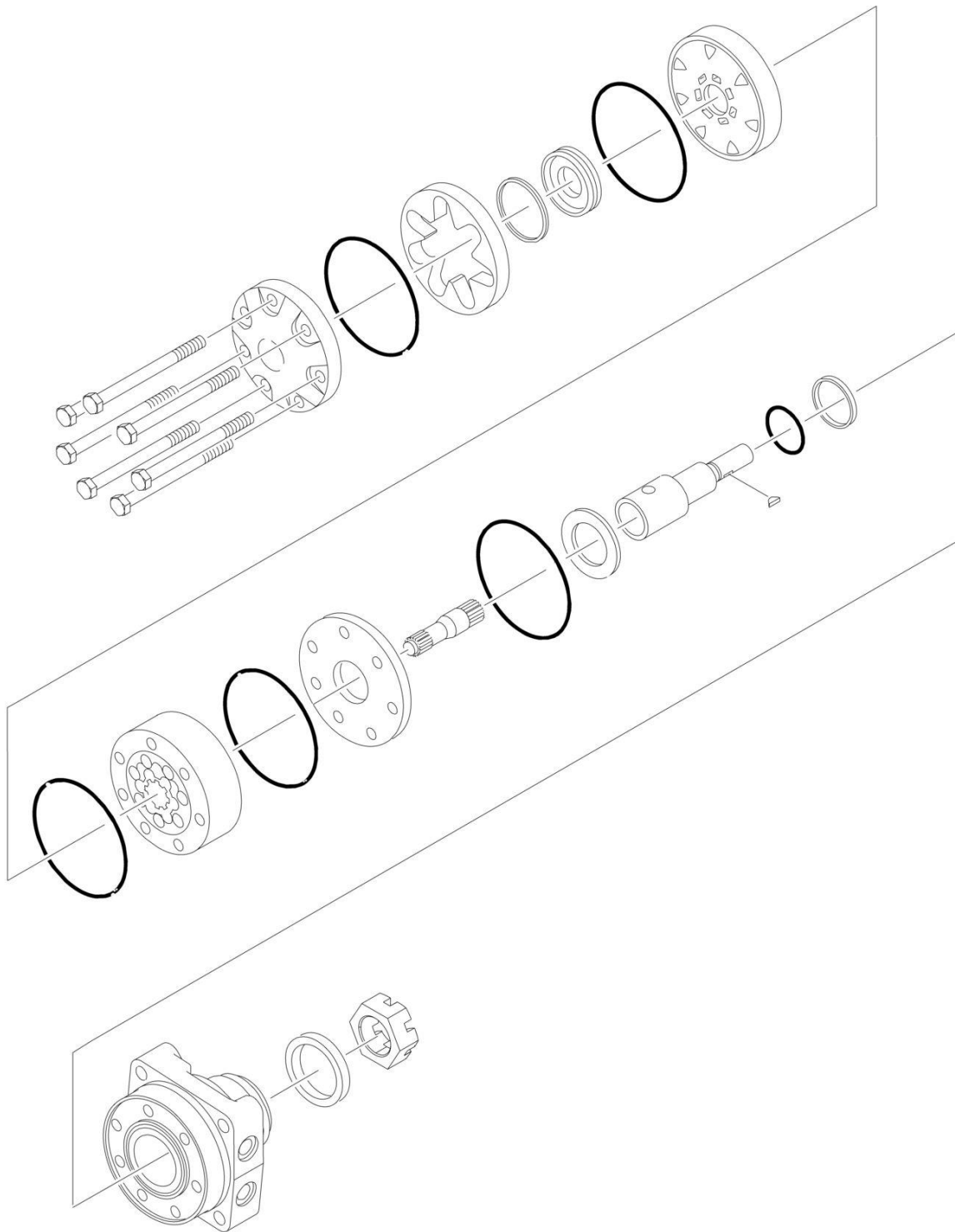

ART_1001289248

SECTION 1 - FRAME

FIGURE 1-7. DRIVE MOTOR ASSEMBLY (MACHINES WITH SN STARTING WITH B2, M2 & G2)

ITEM	PART NUMBER	QTY	DESCRIPTION	REV
	1001289248 See Note	Ref Ref	DRIVE MOTOR ASSEMBLY Note: No Other Service Parts Available at Time of Printing.	A

SECTION 1 - FRAME

FIGURE 1-8. TIRE AND WHEEL INSTALLATION

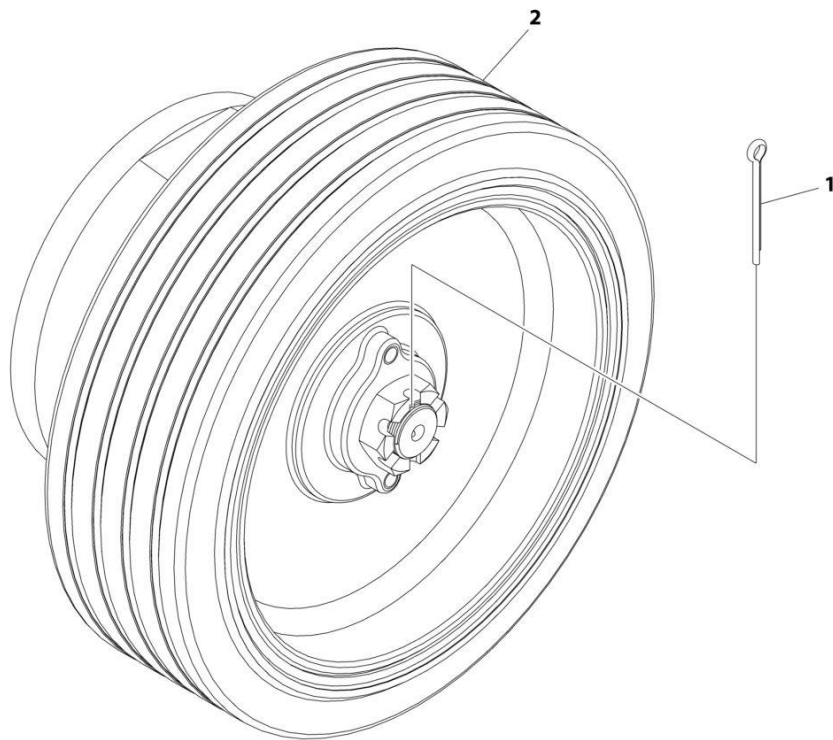

ART_1001202731

SECTION 1 - FRAME

FIGURE 1-8. TIRE AND WHEEL INSTALLATION

ITEM	PART NUMBER	QTY	DESCRIPTION	REV
	1001202731	Ref	TIRE AND WHEEL INSTALLATION	B
		Ref	Note: Must Replace Tire and Wheel Assemblies in pairs per axle.	
1	3450508	4	Pin, Cotter 5/32 x 2	
2	1001200441	4	Tire and Wheel	

SECTION 1 - FRAME

FIGURE 1-9. WHEEL INSTALLATION (MACHINES WITH SN STARTING WITH G2)

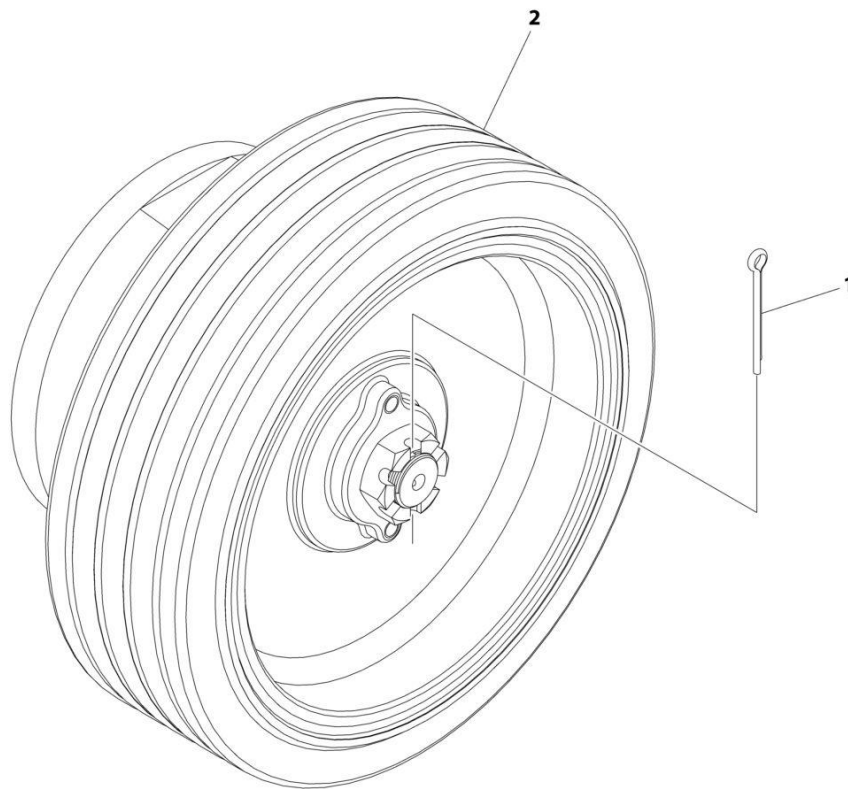

ART_1001276586

SECTION 1 - FRAME

FIGURE 1-9. WHEEL INSTALLATION (MACHINES WITH SN STARTING WITH G2)

ITEM	PART NUMBER	QTY	DESCRIPTION	REV
	1001276586	Ref	WHEEL INSTALLATION	A
		Ref	Note: Must Replace Tire and Wheel Assemblies in pairs per axle.	
1	3450508	4	Pin, Cotter	
2	1001276708	4	Tire and Wheel	

SECTION 1 - FRAME

FIGURE 1-10. POTHOLE PROTECTION SYSTEM INSTALLATION

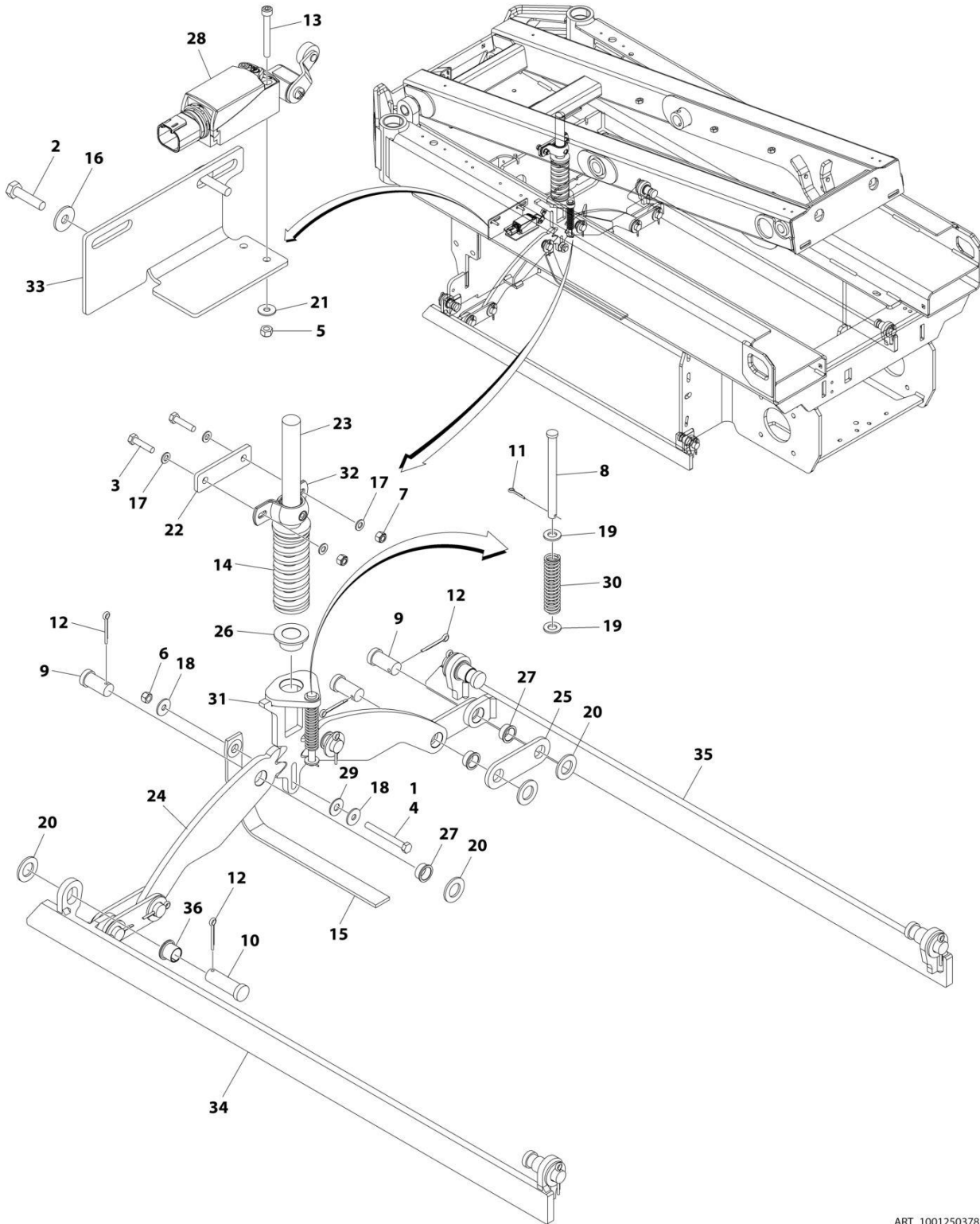

ART_1001250378

SECTION 1 - FRAME

FIGURE 1-10. POTHOLE PROTECTION SYSTEM INSTALLATION

ITEM	PART NUMBER	QTY	DESCRIPTION	REV
	1001250378	Ref	POTHOLE PROTECTION INSTALLATION	B
1	0100011	AR	Compound, Locking	
2	0700612	2	Bolt M6 x 25	
3	0700815	2	Bolt M8 x 35	
4	0700823	1	Bolt M8 x 75	
5	3290405	2	Nut M4	
6	3290801	1	Nut M8	
7	3290805	2	Nut M8	
8	3430636	1	Pin	
9	3431212	6	Pin	
10	3431218	4	Pin	
11	3450302	1	Pin, Cotter 7/8 x 1/2	
12	3450505	10	Pin, Cotter 5/32 x 1/2	
13	4031511	2	Capscrew M4 x 35	
14	4160202	1	Spring	
15	4240147	1	Strap, Anti-Static	
16	4811702	2	Washer M6	
17	4811900	4	Washer M8	
18	4811902	2	Washer M8	
19	4812000	2	Washer M10	
20	4812500	10	Washer M20	
21	1001091102	2	Washer M4	
22	1001202987	1	Plate, Mounting	
23	1001202988	1	Actuator (Upper)	
24	1001202994	2	Plate, Pinion	
25	1001202999	4	Link	
26	1001203869	1	Bearing	
27	1001203870	6	Bearing	
28	1001203871	1	Switch, Limit	
29	1001203872	1	Washer 3/8	
30	1001212068	1	Spring	
31	1001214526	1	Actuator (Lower)	
32	1001215953	1	Bearing	
33	1001218307	1	Plate, Sensor Mount	
34	1001251436	1	Bar (LH)	
35	1001251437	1	Bar (RH)	
36	0440263	4	Bearing	

SECTION 1 - FRAME

FIGURE 1-11. POTHOLE PROTECTION SYSTEM INSTALLATION (MACHINES WITH SN STARTING WITH G2)

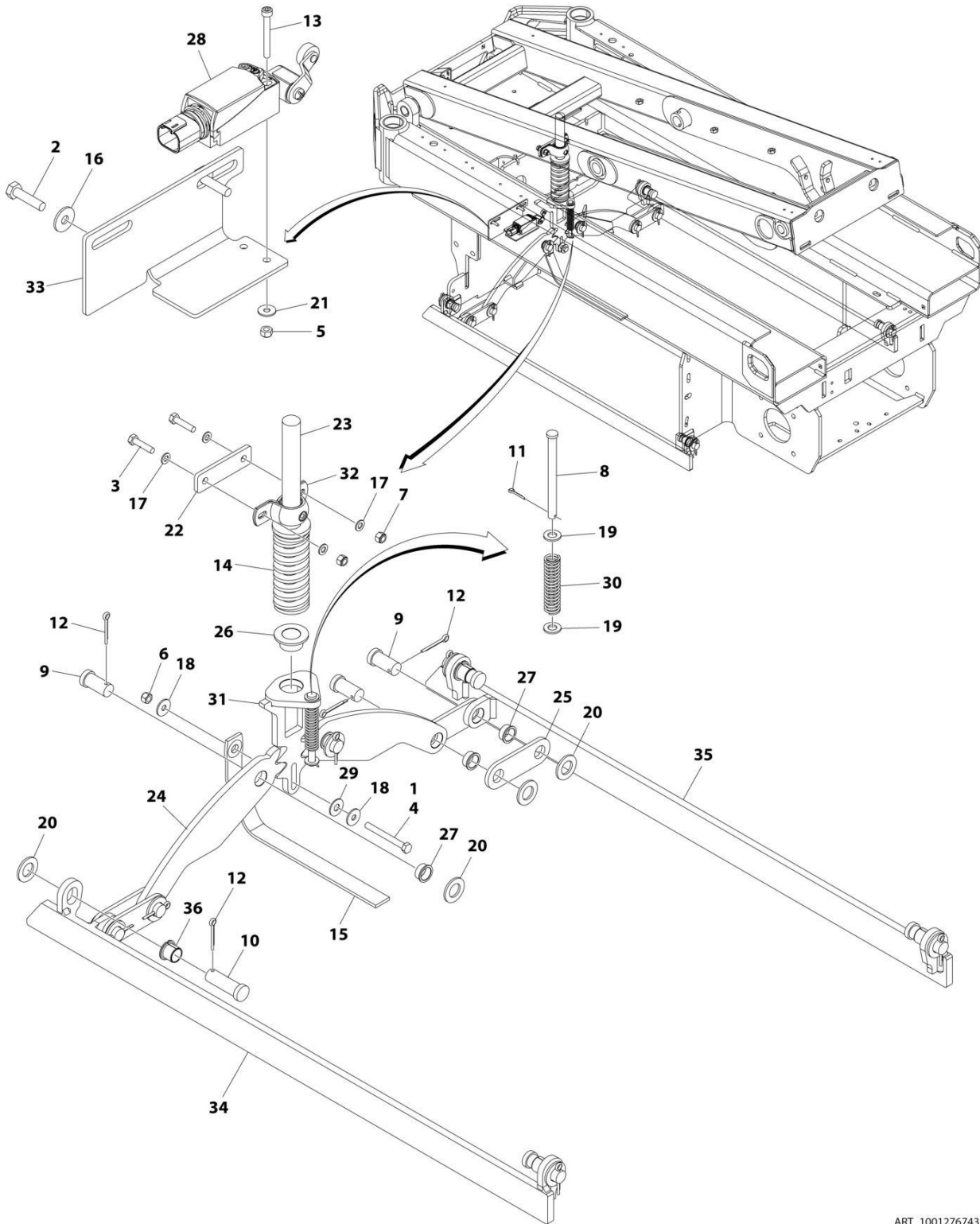

ART_1001276743

SECTION 1 - FRAME

FIGURE 1-11. POTHOLE PROTECTION SYSTEM INSTALLATION (MACHINES WITH SN STARTING WITH G2)

ITEM	PART NUMBER	QTY	DESCRIPTION	REV
	1001276743	Ref	POTHOLE PROTECTION SYSTEM INSTALLATION	A
1	0100011	AR	Compound, Locking	
2	0700612	2	Bolt M6 x 25	
3	0700815	2	Bolt M8 x 35	
4	0700823	1	Bolt M8 x 75	
5	3290405	2	Nut M4	
6	3290801	1	Nut M8	
7	3290805	2	Nut M8	
8	3430636	1	Pin	
9	3431212	6	Pin	
10	3431218	4	Pin	
11	3450302	1	Pin, Cotter 7/8 x 1/2	
12	3450505	10	Pin, Cotter 5/32 x 1/2	
13	4031511	2	Capscrew M4 x 35	
14	1001276718	1	Spring	
15	4240147	1	Strap, Anti-Static	
16	4811702	2	Washer M6	
17	4811900	4	Washer M8	
18	4811902	2	Washer M8	
19	4812000	2	Washer M10	
20	4812500	10	Washer M20	
21	1001091102	2	Washer M4	
22	1001202987	1	Plate, Mounting	
23	1001202988	1	Actuator (Upper)	
24	1001202994	2	Plate, Pinion	
25	1001202999	4	Link	
26	1001276720	1	Bearing	
27	1001276721	6	Bearing	
28	1001276741	1	Switch, Limit	
29	1001203872	1	Washer 3/8	
30	1001212068	1	Spring	
31	1001214526	1	Actuator (Lower)	
32	1001215953	1	Bearing	
33	1001218307	1	Plate, Sensor Mount	
34	1001251436	1	Bar (LH)	
35	1001251437	1	Bar (RH)	
36	1001276722	4	Bearing	

SECTION 1 - FRAME

FIGURE 1-12. TILT SENSOR INSTALLATION

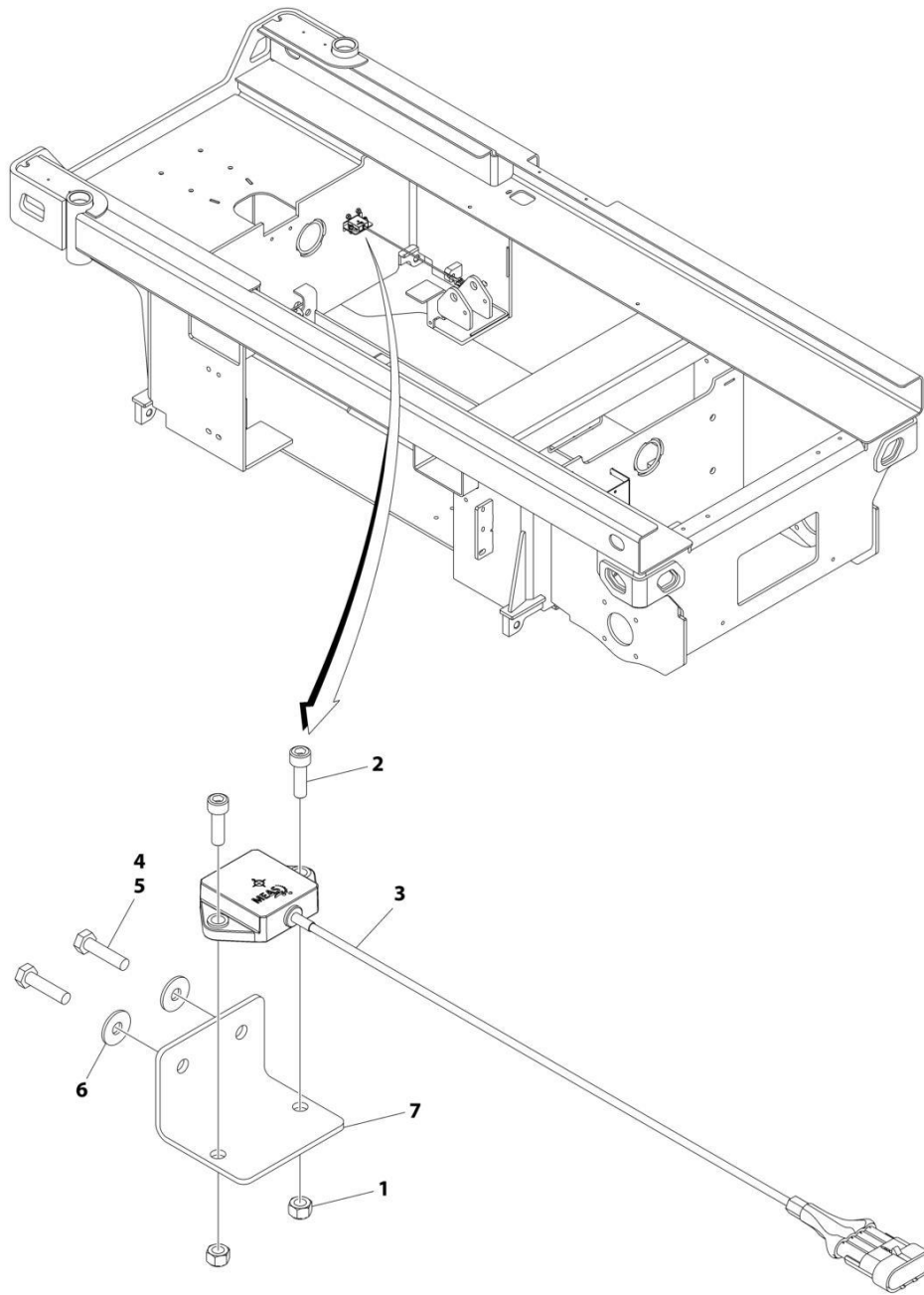

ART_1001214217

FIGURE 1-12. TILT SENSOR INSTALLATION

ITEM	PART NUMBER	QTY	DESCRIPTION	REV
	1001214217	Ref	TILT SENSOR INSTALLATION	D
1	3290601	2	Nut M6	
2	4031708	2	Capscrew M6 x 20	
3	1001186466	1	Sensor, Tilt	
4	0100011	AR	Compound, Locking	
5	0700612	2	Bolt M6 x 25	
6	4811702	2	Washer M6	
7	1001217059	1	Plate, Mounting	

SECTION 1 - FRAME

FIGURE 1-13. BATTERY CHARGER INSTALLATION - DELTA-Q (WITHOUT COMMUNICATION PORT) (LOCALLY SUPPLIED PLUG)

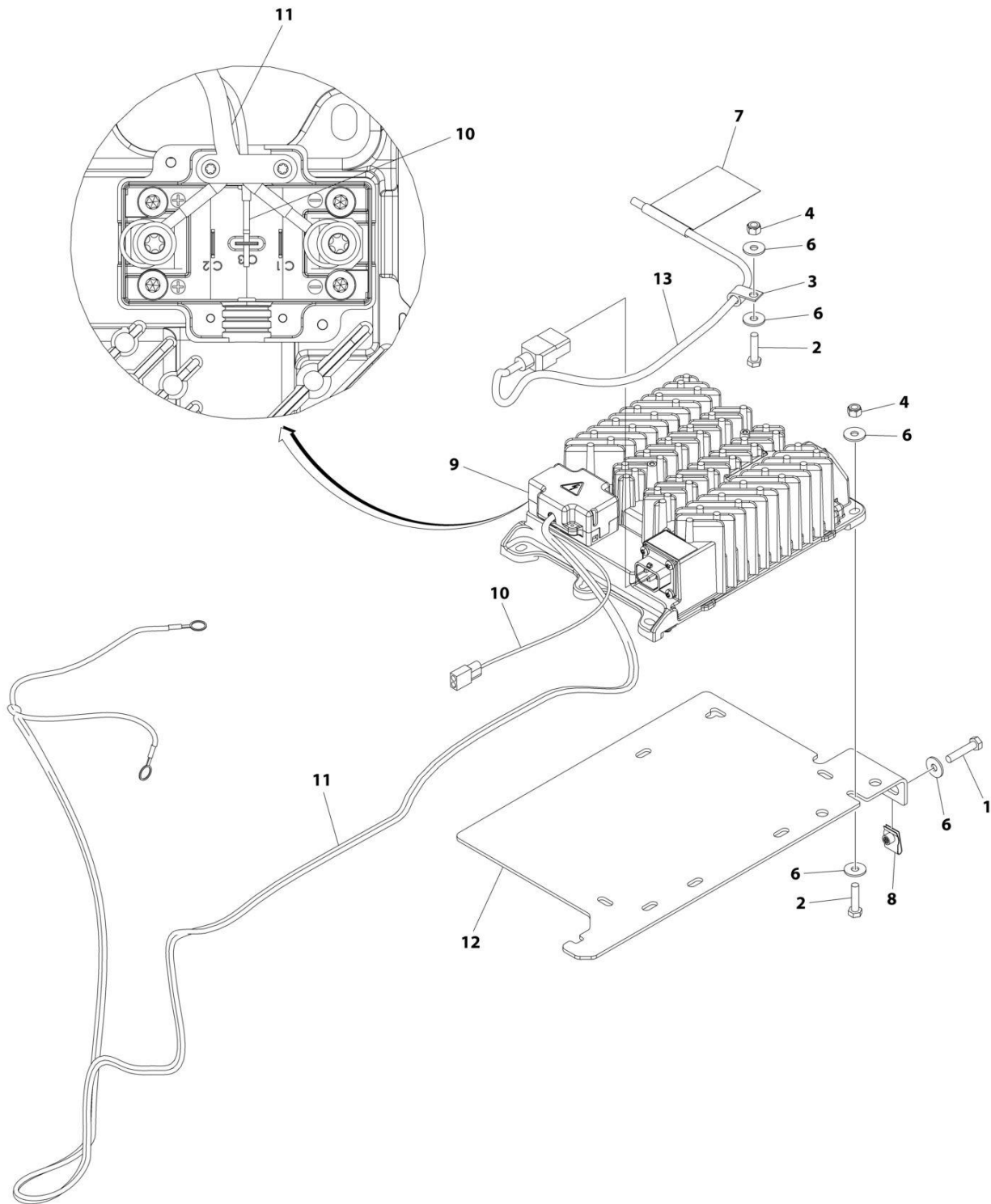

ART_1001235153

SECTION 1 - FRAME

**FIGURE 1-13. BATTERY CHARGER INSTALLATION - DELTA-Q (WITHOUT COMMUNICATION PORT)
(LOCALLY SUPPLIED PLUG)**

ITEM	PART NUMBER	QTY	DESCRIPTION	REV
	1001235153	Ref	BATTERY CHARGER INSTALLATION - DELTA-Q (LOCALLY SUPPLIED PLUG)	C
1	0700614	2	Bolt M6 x 30	
2	0760612	3	Bolt M6 x 25	
3	1321293	1	Clamp	
4	3290605	3	Nut M6	
5	4240017	AR	Tie-Strap (Not Shown)	
6	4811702	8	Washer M6	
7	1001102489	1	Decal - Charger	
8	1001130220	2	Nut, Tinnerman M6	
9	1001200561	1	Charger, Battery - Delta-Q	
10	1001207009	1	Charger Interlock Harness	
10	4460424	1	Receptacle, Female - 2 Position	
10	4460227	2	Pin, Male	
11	1001235105	1	Charger DC Connection Harness	
12	1001236139	1	Bracket	
13	1001207974	1	Cable, Charger AC Input	

SECTION 1 - FRAME

FIGURE 1-14. BATTERY CHARGER INSTALLATION - DELTA-Q (WITH COMMUNICATION PORT) (LOCALLY SUPPLIED PLUG)

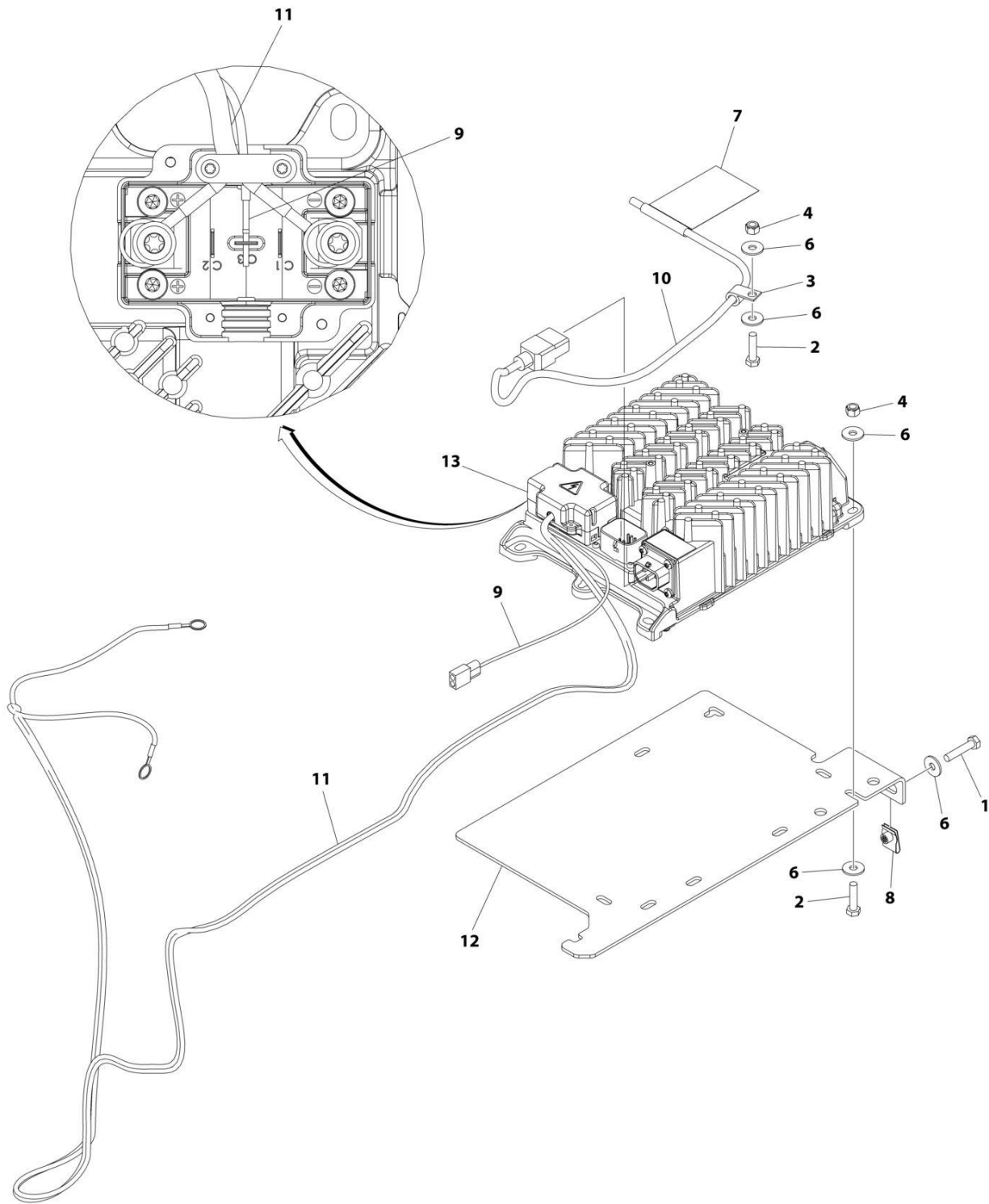

ART_1001253654

SECTION 1 - FRAME

**FIGURE 1-14. BATTERY CHARGER INSTALLATION - DELTA-Q (WITH COMMUNICATION PORT)
(LOCALLY SUPPLIED PLUG)**

ITEM	PART NUMBER	QTY	DESCRIPTION	REV
	1001253654	Ref	BATTERY CHARGER INSTALLATION - DELTA-Q (LOCALLY SUPPLIED PLUG)	A
1	0700614	2	Bolt M6 x 30	
2	0760612	3	Bolt M6 x 25	
3	1321293	1	Clamp	
4	3290605	3	Nut M6	
5	4240017	AR	Tie-Strap (Not Shown)	
6	4811702	8	Washer M6	
7	1001102489	1	Decal - Charger Label	
8	1001130220	2	Nut, Tinnerman M6	
9	1001207009	1	Charger Interlock Harness	
9	4460424	1	Receptacle, Female - 2 Position	
9	4460227	2	Pin, Male	
10	1001207974	1	Battery Charger to AC Connection Cable	
11	1001235105	1	Battery Charger to DC Connection Cable	
12	1001236139	1	Bracket	
13	1001253952	1	Charger, Battery - Delta-Q	
14	1001254027	1	Can Splice Harness (Not Shown - See Separate Breakdown in ELECTRICAL SECTION)	
15	1001254028	1	Charger To Battery Harness (Not Shown - See Separate Breakdown in ELECTRICAL SECTION)	

SECTION 1 - FRAME

FIGURE 1-15. BATTERY CHARGER INSTALLATION - DELTA-Q (WITHOUT COMMUNICATION PORT)
(110V PLUG) (R1532i)

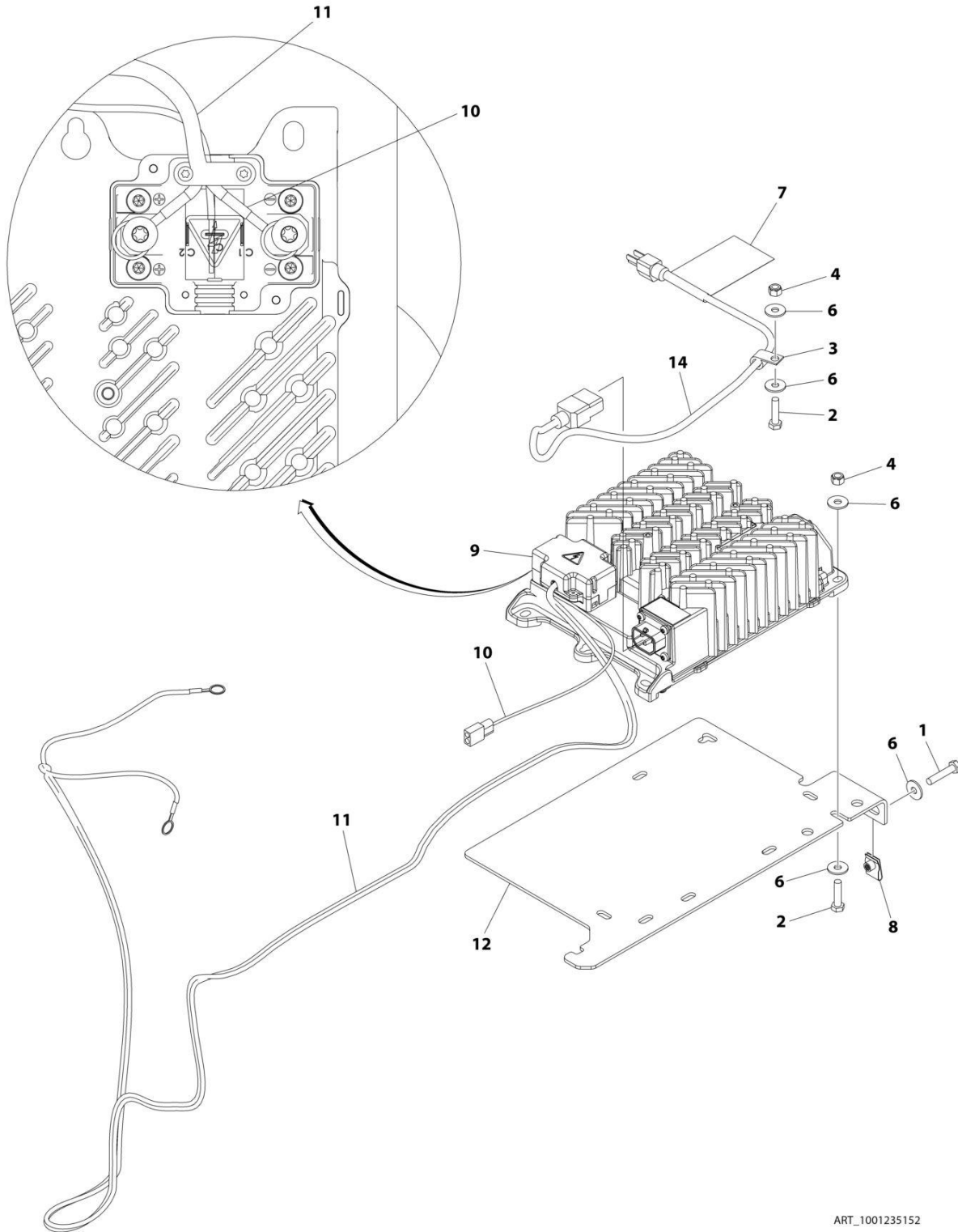

ART_1001235152

SECTION 1 - FRAME

**FIGURE 1-15. BATTERY CHARGER INSTALLATION - DELTA-Q (WITHOUT COMMUNICATION PORT)
(110V PLUG) (R1532I)**

ITEM	PART NUMBER	QTY	DESCRIPTION	REV
	1001235152	Ref	BATTERY CHARGER INSTALLATION - DELTA-Q (110V PLUG)	B
1	0700614	2	Bolt M6 x 30	
2	0760612	3	Bolt M6 x 25	
3	1321293	1	Clamp	
4	3290605	3	Nut M6	
5	4240017	AR	Tie-Strap (Not Shown)	
6	4811702	8	Washer M6	
7	1001102489	1	Decal - Charger	
8	1001130220	2	Nut Tinnerman, M6	
9	1001200561	1	Charger, Battery - Delta-Q	
10	1001207009	1	Charger Interlock Harness	
10	4460424	1	Receptacle, Female - 2 Position	
10	4460227	2	Pin, Male	
11	1001235105	1	Charger DC Connection Harness	
12	1001236139	1	Bracket	
14	1001207970	1	Charger AC Input Cable	

SECTION 1 - FRAME

FIGURE 1-16. BATTERY CHARGER INSTALLATION - DELTA-Q (WITH COMMUNICATION PORT) (110V PLUG) (R1532I)

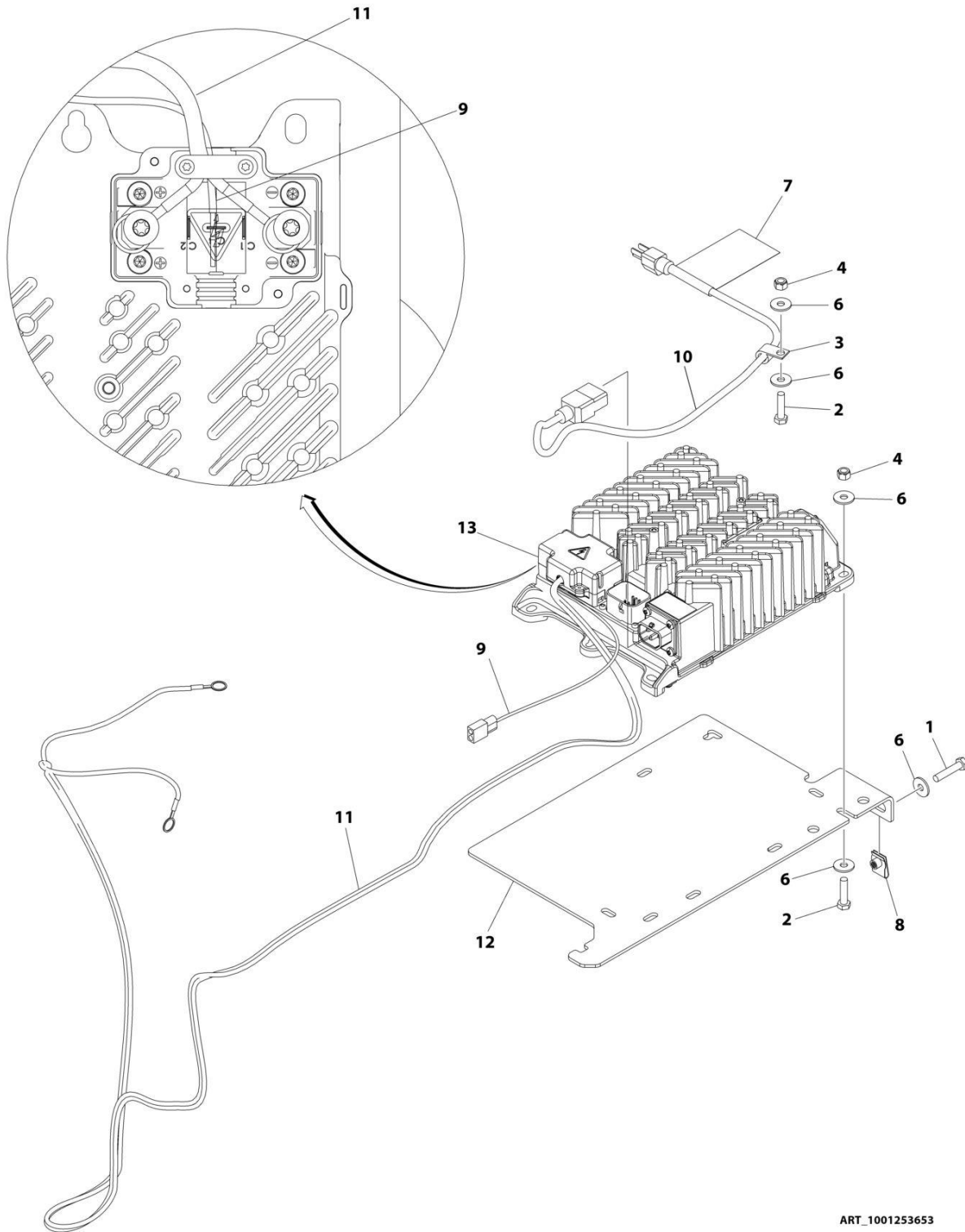

ART_1001253653

SECTION 1 - FRAME

**FIGURE 1-16. BATTERY CHARGER INSTALLATION - DELTA-Q (WITH COMMUNICATION PORT)
(110V PLUG) (R1532I)**

ITEM	PART NUMBER	QTY	DESCRIPTION	REV
	1001253653	Ref	BATTERY CHARGER INSTALLATION - DELTA-Q (110V PLUG)	A
1	0700614	2	Bolt M6 x 30	
2	0760612	3	Bolt M6 x 25	
3	1321293	1	Clamp	
4	3290605	3	Nut M6	
5	4240017	AR	Tie-Strap (Not Shown)	
6	4811702	8	Washer M6	
7	1001102489	1	Decal - Charger Label	
8	1001130220	2	Nut, Tinnerman M6	
9	1001207009	1	Charger Interlock Harness	
9	4460424	1	Receptacle, Female - 2 Position	
9	4460227	2	Pin, Male	
10	1001207970	1	Battery Charger to AC Connection Cable	
11	1001235105	1	Battery Charger to DC Connection Cable	
12	1001236139	1	Bracket	
13	1001253952	1	Charger, Battery - Delta-Q	
14	1001254027	1	Can Splice Harness (Not Shown - See Separate Breakdown in ELECTRICAL SECTION)	
15	1001254028	1	Charger To Battery Harness (Not Shown - See Separate Breakdown in ELECTRICAL SECTION)	

SECTION 1 - FRAME

FIGURE 1-17. BATTERY CHARGER INSTALLATION - DELTA-Q (WITHOUT COMMUNICATION PORT)
(KOREAN PLUG) (R1532i)

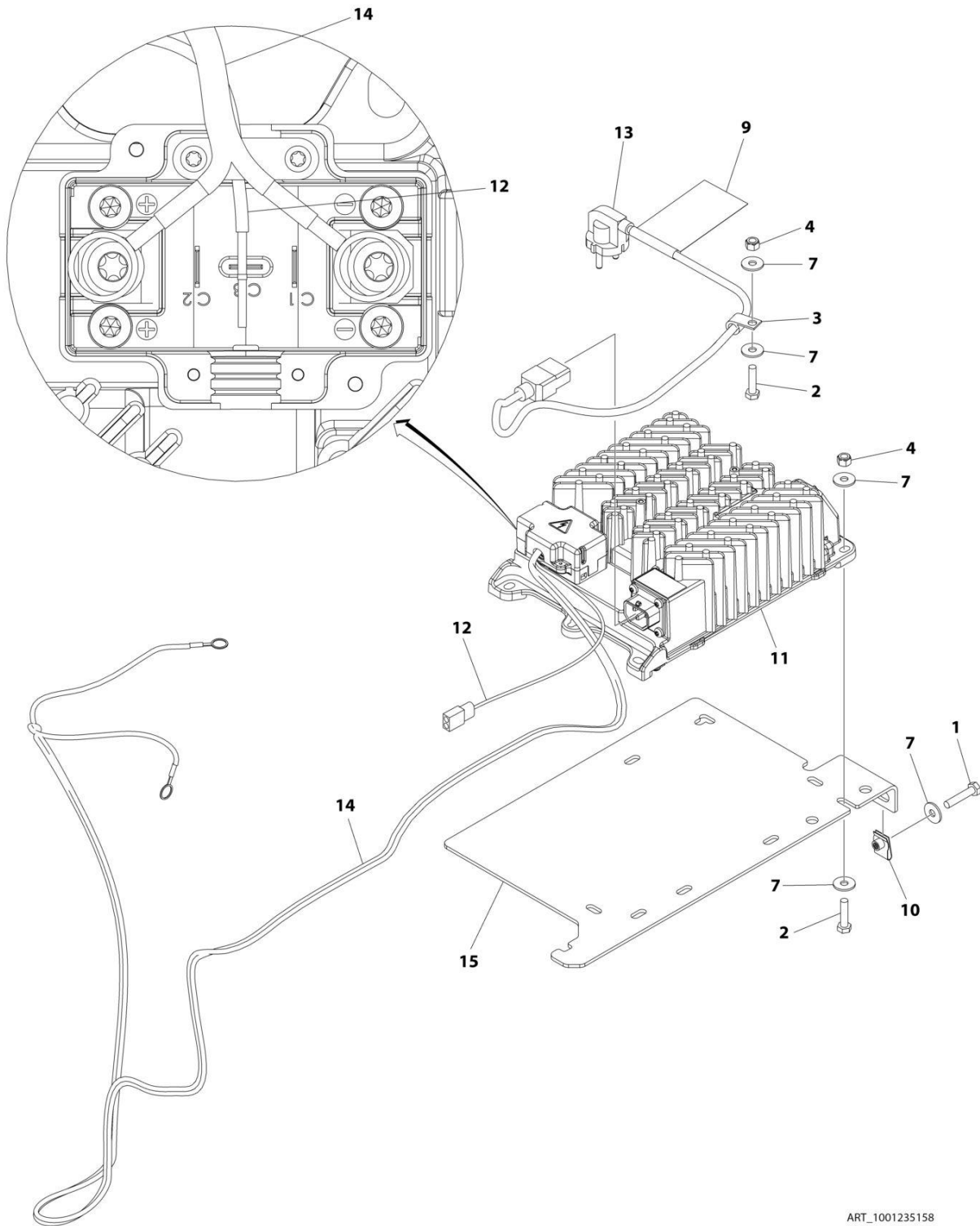

ART_1001235158

SECTION 1 - FRAME

**FIGURE 1-17. BATTERY CHARGER INSTALLATION - DELTA-Q (WITHOUT COMMUNICATION PORT)
(KOREAN PLUG) (R1532I)**

ITEM	PART NUMBER	QTY	DESCRIPTION	REV
	1001235158	Ref	BATTERY CHARGER INSTALLATION - DELTA-Q (KOREAN PLUG)	C
1	0700614	2	Bolt M6 x 30	
2	0760612	3	Bolt M6 x 25	
3	1321293	1	Clamp	
4	3290605	3	Nut M6	
6	4240017	AR	Tie-Strap (Not Shown)	
7	4811702	8	Washer M6	
9	1001102489	1	Decal - Charger	
10	1001130220	2	Nut, Tinnerman M6	
11	1001200561	1	Charger, Battery - Delta-Q	
12	1001207009	1	Charger Interlock Harness	
12	4460424	1	Receptacle, Female - 2 Position	
12	4460227	2	Pin, Male	
13	1001221949	1	Cable, Charger AC Input (With Korean Plug)	
14	1001235105	1	Charger DC Connection Harness	
15	1001236139	1	Bracket	

SECTION 1 - FRAME

FIGURE 1-18. BATTERY CHARGER INSTALLATION - DELTA-Q (WITH COMMUNICATION PORT) (KOREAN PLUG) (R1532I)

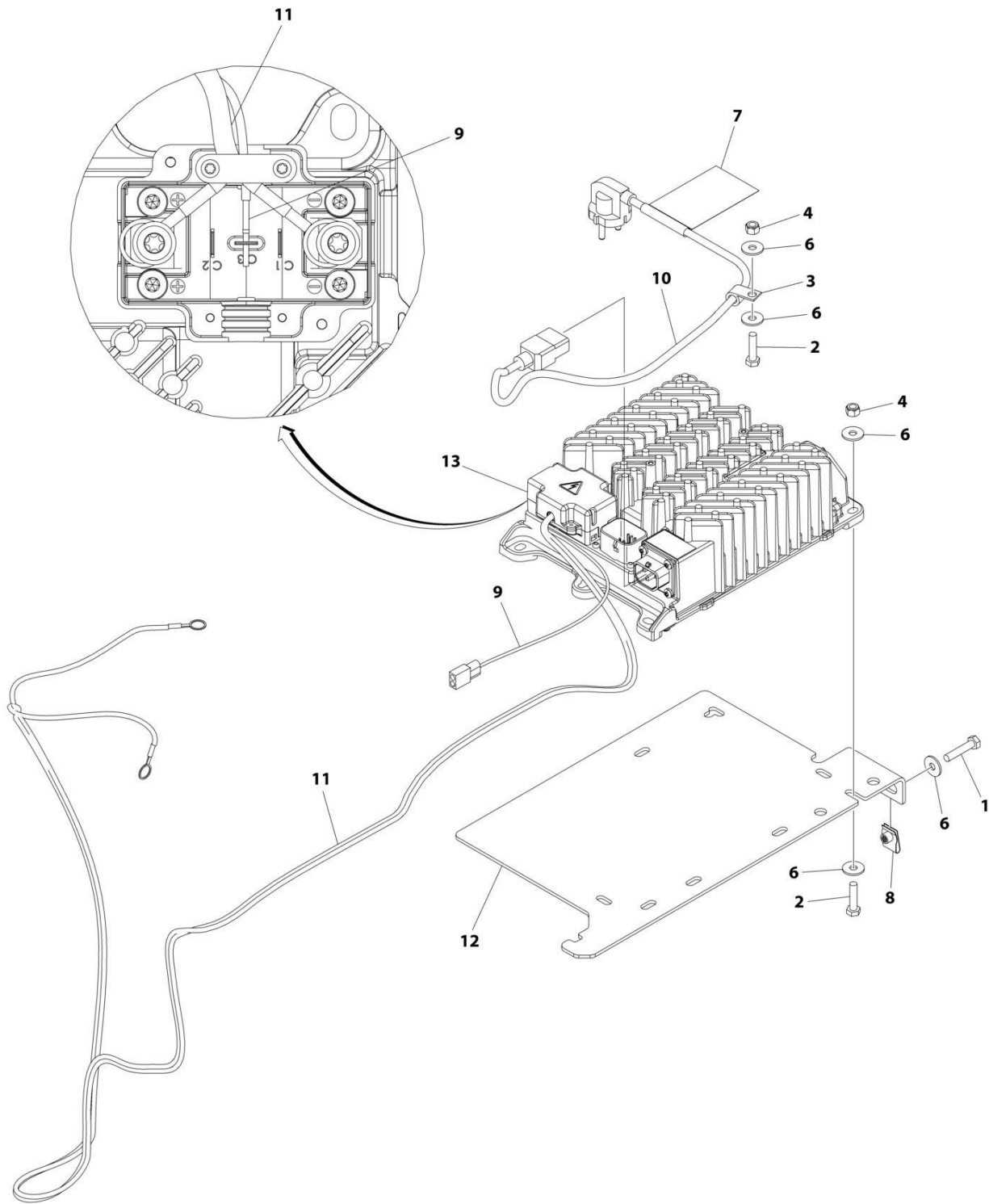

ART_1001253655

SECTION 1 - FRAME

**FIGURE 1-18. BATTERY CHARGER INSTALLATION - DELTA-Q (WITH COMMUNICATION PORT)
(KOREAN PLUG) (R1532I)**

ITEM	PART NUMBER	QTY	DESCRIPTION	REV
	1001253655	Ref	BATTERY CHARGER INSTALLATION - DELTA-Q (KOREAN PLUG)	A
1	0700614	2	Bolt M6 x 30	
2	0760612	3	Bolt M6 x 25	
3	1321293	1	Clamp	
4	3290605	3	Nut M6	
5	4240017	AR	Tie-Strap (Not Shown)	
6	4811702	8	Washer M6	
7	1001102489	1	Decal - Charger Label	
8	1001130220	2	Nut, Tinnerman M6	
9	1001207009	1	Charger Interlock Harness	
9	4460424	1	Receptacle, Female - 2 Position	
9	4460227	2	Pin, Male	
10	1001221949	1	Battery Charger to AC Connection Cable	
11	1001235105	1	Battery Charger to DC Connection Cable	
12	1001236139	1	Bracket	
13	1001253952	1	Charger, Battery - Delta-Q	
14	1001254027	1	Can Splice Harness (Not Shown - See Separate Breakdown in ELECTRICAL SECTION)	
15	1001254028	1	Charger to Battery Harness (Not Shown - See Separate Breakdown in ELECTRICAL SECTION)	

SECTION 1 - FRAME

FIGURE 1-19. BATTERY CHARGER INSTALLATION - GREEN POWER (CHINA PLUG) (MACHINES WITH SN STARTING WITH B2) (R1532I)

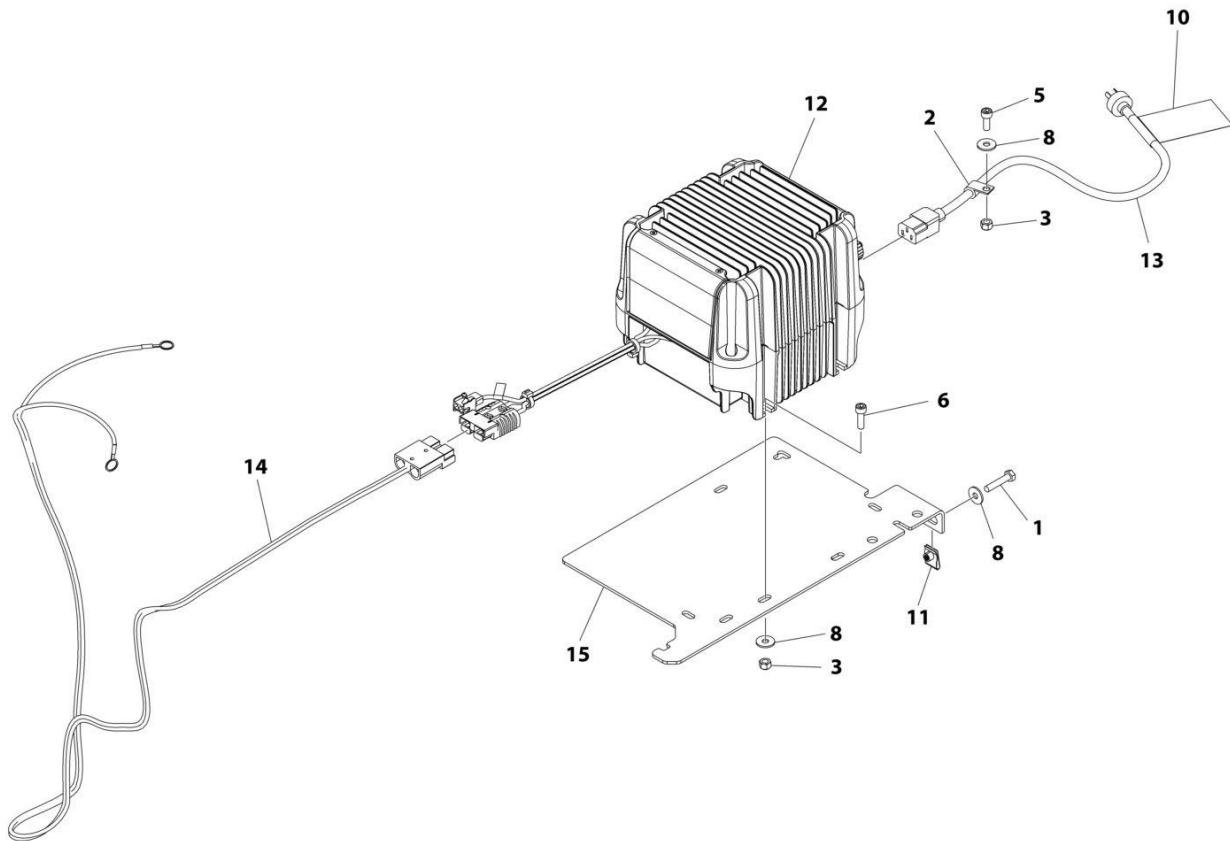

ART_1001235154

SECTION 1 - FRAME

FIGURE 1-19. BATTERY CHARGER INSTALLATION - GREEN POWER (CHINA PLUG) (MACHINES WITH SN STARTING WITH B2) (R1532I)

ITEM	PART NUMBER	QTY	DESCRIPTION	REV
	1001235154	Ref	BATTERY CHARGER INSTALLATION - GREEN POWER (CHINA PLUG)	C
1	0700614	2	Bolt M6 x 30	
2	1321293	1	Clamp, Cable	
3	3290605	4	Nut, M6	
5	4031707	1	Capscrew M6 x 16	
6	4031708	3	Capscrew M6 x 20	
7	4240017	AR	Tie-Strap (Not Shown)	
8	4811702	6	Washer M6	
10	1001102489	1	Decal - Charger	
11	1001130220	2	Nut, Tinnerman M6	
12	1001205598	1	Charger, Battery Green Power	
13	1001207973	1	Cable, Charger AC Input	
14	1001235946	1	Charger DC Connection Harness	
15	1001236139	1	Bracket	

SECTION 1 - FRAME

FIGURE 1-20. BATTERY CHARGER INSTALLATION - EAGLE PERFORMANCE (110V PLUG)
(MACHINES WITH SN STARTING WITH M2) (R1532i)

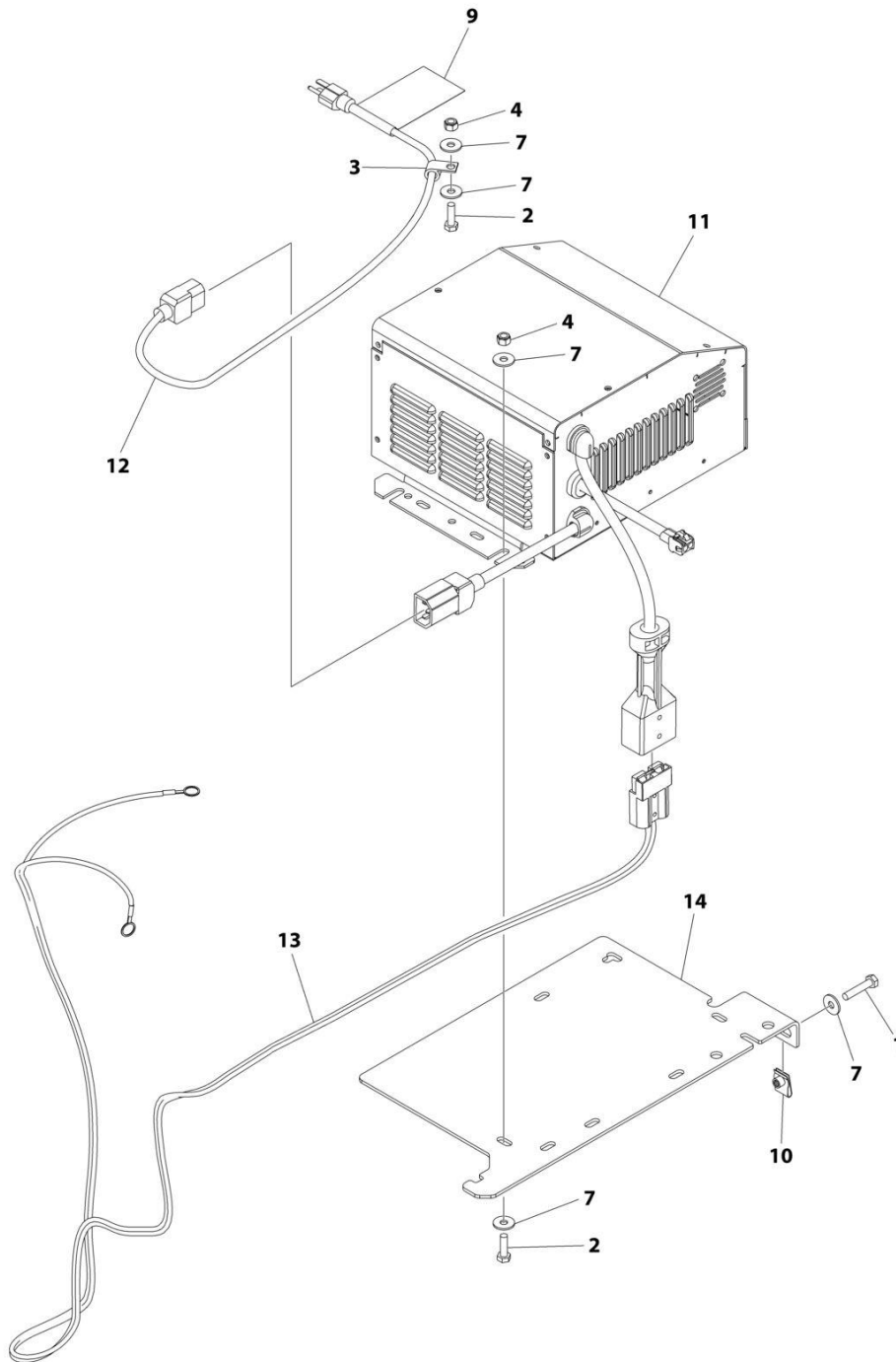

ART_1001235157

SECTION 1 - FRAME

**FIGURE 1-20. BATTERY CHARGER INSTALLATION - EAGLE PERFORMANCE (110V PLUG)
(MACHINES WITH SN STARTING WITH M2) (R1532I)**

ITEM	PART NUMBER	QTY	DESCRIPTION	REV
	1001235157	Ref	BATTERY CHARGER INSTALLATION - EAGLE PERFORMANCE (110V PLUG)	C
1	0700614	2	Bolt M6 x 30	
2	0760610	3	Bolt M6 x 20	
3	1321293	1	Clamp	
4	3290605	3	Nut M6	
6	4240017	AR	Tie-Strap (Not Shown)	
7	4811702	8	Washer M6	
9	1001102489	1	Decal - Charger	
10	1001130220	2	Nut, Tinnerman M6	
11	1001206995	1	Charger, Battery - Eagle Performance	
12	1001207970	1	Cable, Charger AC Input	
13	1001235946	1	Charger DC Connection Harness	
14	1001236139	1	Bracket	

SECTION 1 - FRAME

FIGURE 1-21. BATTERY CHARGER INSTALLATION - GREEN POWER (LOCALLY SUPPLIED PLUG)
(MACHINES WITH SN STARTING WITH B2) (R1532i)

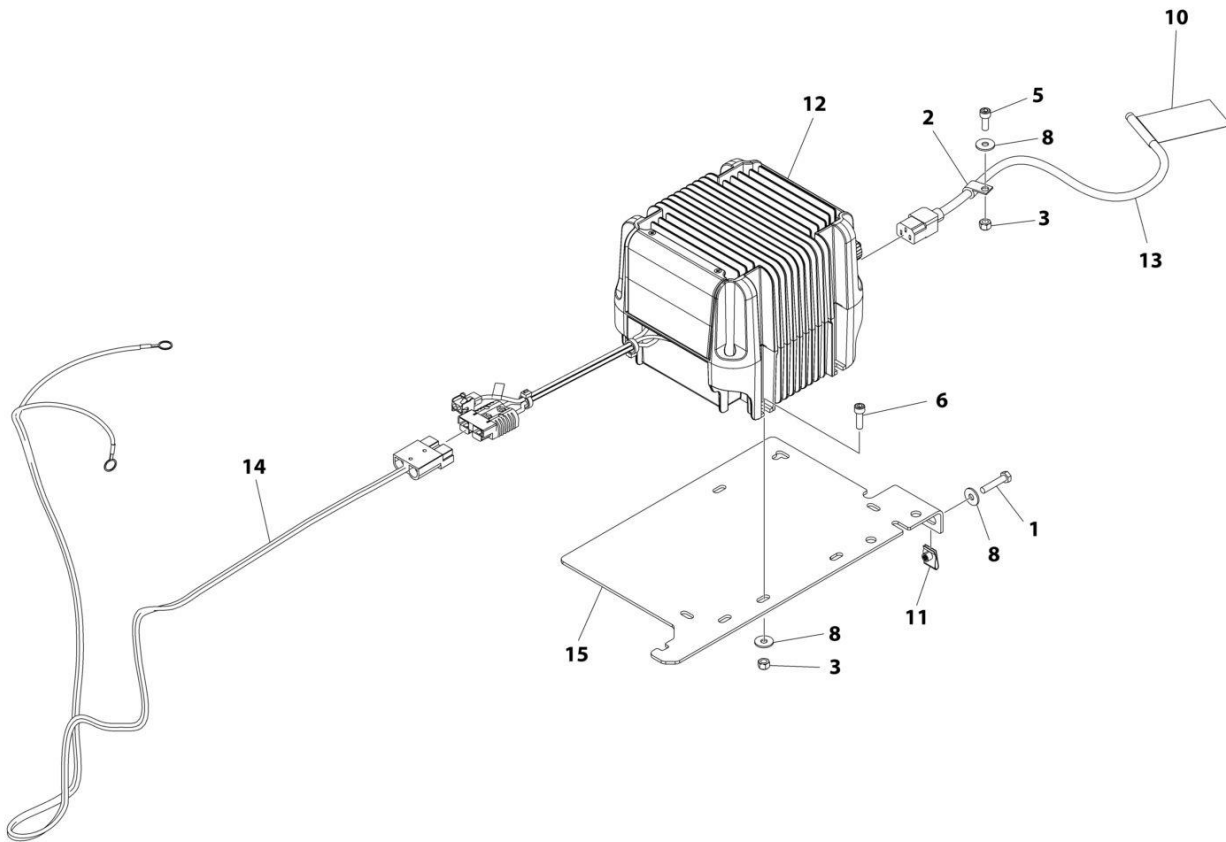

ART_1001235156

SECTION 1 - FRAME

**FIGURE 1-21. BATTERY CHARGER INSTALLATION - GREEN POWER (LOCALLY SUPPLIED PLUG)
(MACHINES WITH SN STARTING WITH B2) (R1532I)**

ITEM	PART NUMBER	QTY	DESCRIPTION	REV
	1001235156	Ref	BATTERY CHARGER INSTALLATION - GREEN POWER (LOCALLY SUPPLIED PLUG)	C
1	0700614	2	Bolt M6 x 30	
2	1321293	1	Clamp, Cable	
3	3290605	4	Nut M6	
5	4031707	1	Capscrew M6 x 16	
6	4031708	3	Capscrew M6 x 20	
7	4240017	AR	Tie-Strap (Not Shown)	
8	4811702	6	Washer M6	
10	1001102489	1	Decal - Charger	
11	1001130220	2	Nut, Tinnerman M6	
12	1001205598	1	Charger, Battery Green Power	
13	1001207974	1	Cable, Charger AC Input	
14	1001235946	1	Charger DC Connection Harness	
15	1001236139	1	Bracket	

SECTION 1 - FRAME

FIGURE 1-22. BATTERY CHARGER INSTALLATION - DELTA-Q (WITHOUT COMMUNICATION PORT)
(R1932i/R1932)

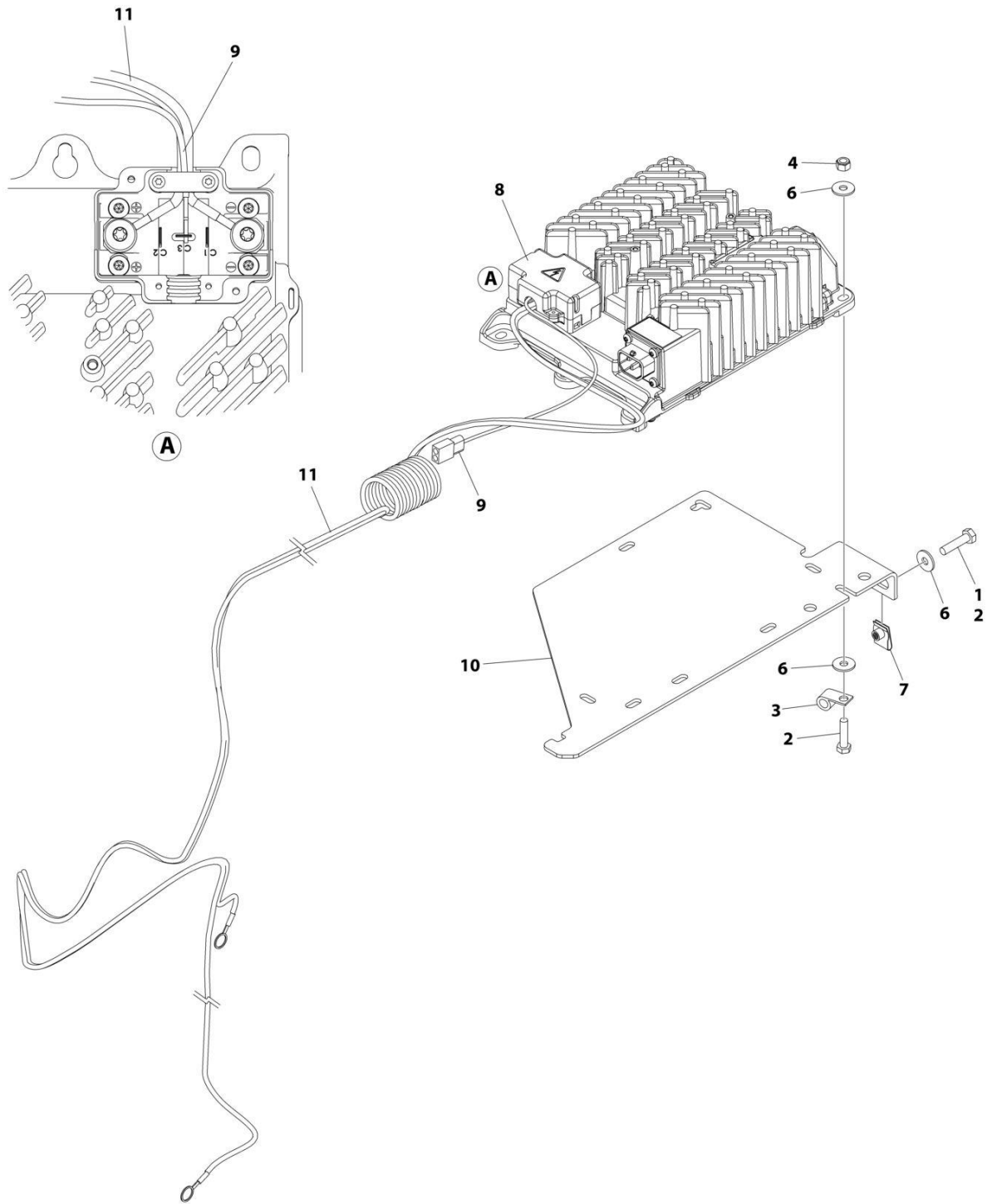

ART_1001263256

SECTION 1 - FRAME

**FIGURE 1-22. BATTERY CHARGER INSTALLATION - DELTA-Q (WITHOUT COMMUNICATION PORT)
(R1932I/R1932)**

ITEM	PART NUMBER	QTY	DESCRIPTION	REV
	1001263256	Ref	BATTERY CHARGER INSTALLATION - DELTA-Q	A
1	0100011	AR	Compound, Locking	
2	0760612	5	Bolt M6 x 25	
3	1321293	1	Clamp	
4	3290605	3	Nut M6	
5	4240017	AR	Tie-Strap (Not Shown)	
6	4811702	8	Washer M6	
7	1001130220	2	Nut, Tinnerman M6	
8	1001200561	1	Charger, Battery - Delta-Q	
9	1001207009	1	Charger Interlock Harness	
9	4460424	1	Receptacle, Female - 2 Position	
9	4460227	2	Pin, Male	
10	1001236139	1	Bracket	
11	1001256642	1	Charger DC Connection Harness	

SECTION 1 - FRAME

FIGURE 1-23. BATTERY CHARGER INSTALLATION - DELTA-Q (WITHOUT COMMUNICATION PORT) (R1932i/R1932)

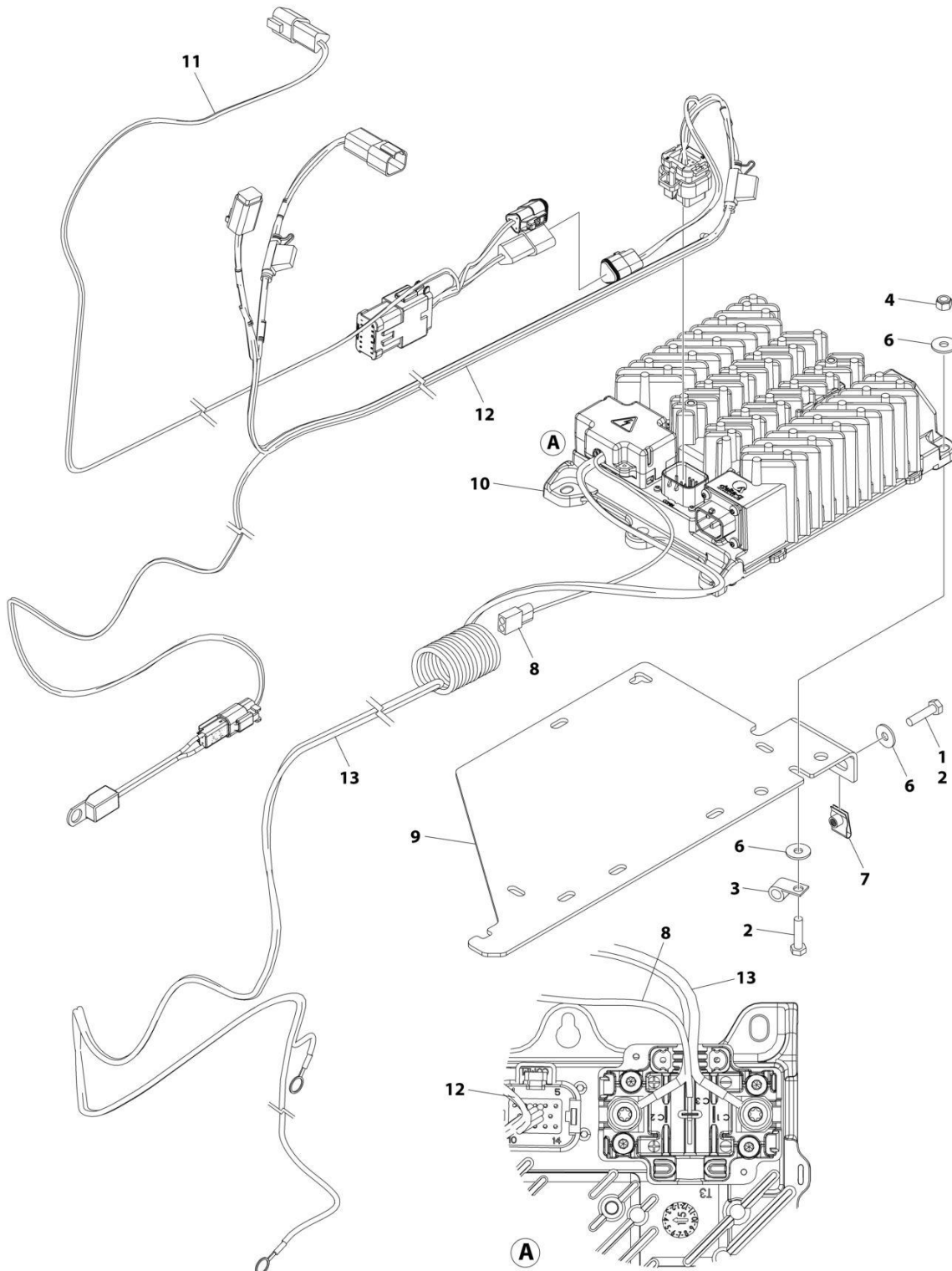

ART_1001263257

SECTION 1 - FRAME

**FIGURE 1-23. BATTERY CHARGER INSTALLATION - DELTA-Q (WITHOUT COMMUNICATION PORT)
(R1932I/R1932)**

ITEM	PART NUMBER	QTY	DESCRIPTION	REV
	1001263257	Ref	BATTERY CHARGER INSTALLATION - DELTA-Q	A
1	0100011	AR	Compound, Locking	
2	0760612	5	Bolt M6 x 25	
3	1321293	1	Clamp	
4	3290605	3	Nut M6	
5	4240017	AR	Tie-Strap (Not Shown)	
6	4811702	8	Washer M6	
7	1001130220	2	Nut, Tinnerman M6	
8	1001207009	1	Charger Interlock Harness	
8	4460424	1	Receptacle, Female - 2 Position	
8	4460227	2	Pin, Male	
9	1001236139	1	Bracket	
10	1001253952	1	Charger, Battery - Delta-Q	
11	1001254027	1	Can Splice Harness (See Separate Breakdown in ELECTRICAL Section)	
12	1001254028	1	Charger To Battery Harness (See Separate Breakdown in ELECTRICAL Section)	
13	1001256642	1	Battery Charger to DC Connection Cable	

SECTION 1 - FRAME

FIGURE 1-24. BATTERY CHARGER INSTALLATION - EAGLE PERFORMANCE (MACHINES WITH SN STARTING WITH M2) (R1932i/R1932)

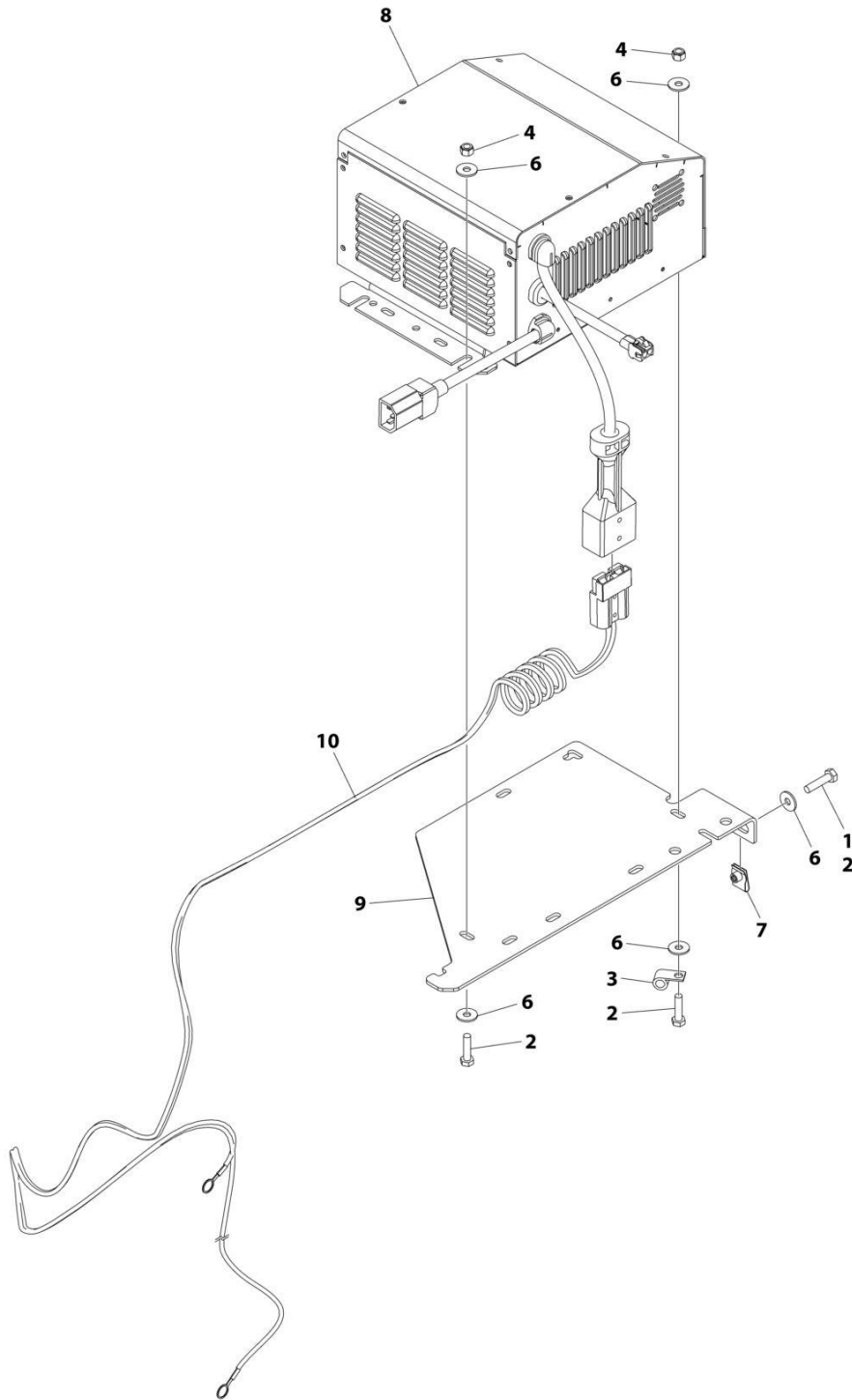

ART_1001263258

SECTION 1 - FRAME

FIGURE 1-24. BATTERY CHARGER INSTALLATION - EAGLE PERFORMANCE (MACHINES WITH SN STARTING WITH M2) (R1932I/R1932)

ITEM	PART NUMBER	QTY	DESCRIPTION	REV
	1001263258	Ref	BATTERY CHARGER INSTALLATION - EAGLE PERFORMANCE	A
1	0100011	AR	Compound, Locking	
2	0760612	5	Bolt M6 x 20	
3	1321293	1	Clamp	
4	3290605	3	Nut M6	
5	4240017	AR	Tie-Strap (Not Shown)	
6	4811702	8	Washer M6	
7	1001130220	2	Nut, Tinnerman M6	
8	1001206995	1	Charger, Battery - Eagle Performance	
9	1001236139	1	Bracket	
10	1001256643	1	Charger DC Connection Harness	

SECTION 1 - FRAME

FIGURE 1-25. BATTERY CHARGER INSTALLATION - GREEN POWER (LOCALLY SUPPLIED PLUG)
(MACHINES WITH SN STARTING WITH B2 & G2) (R1932i/R1932)

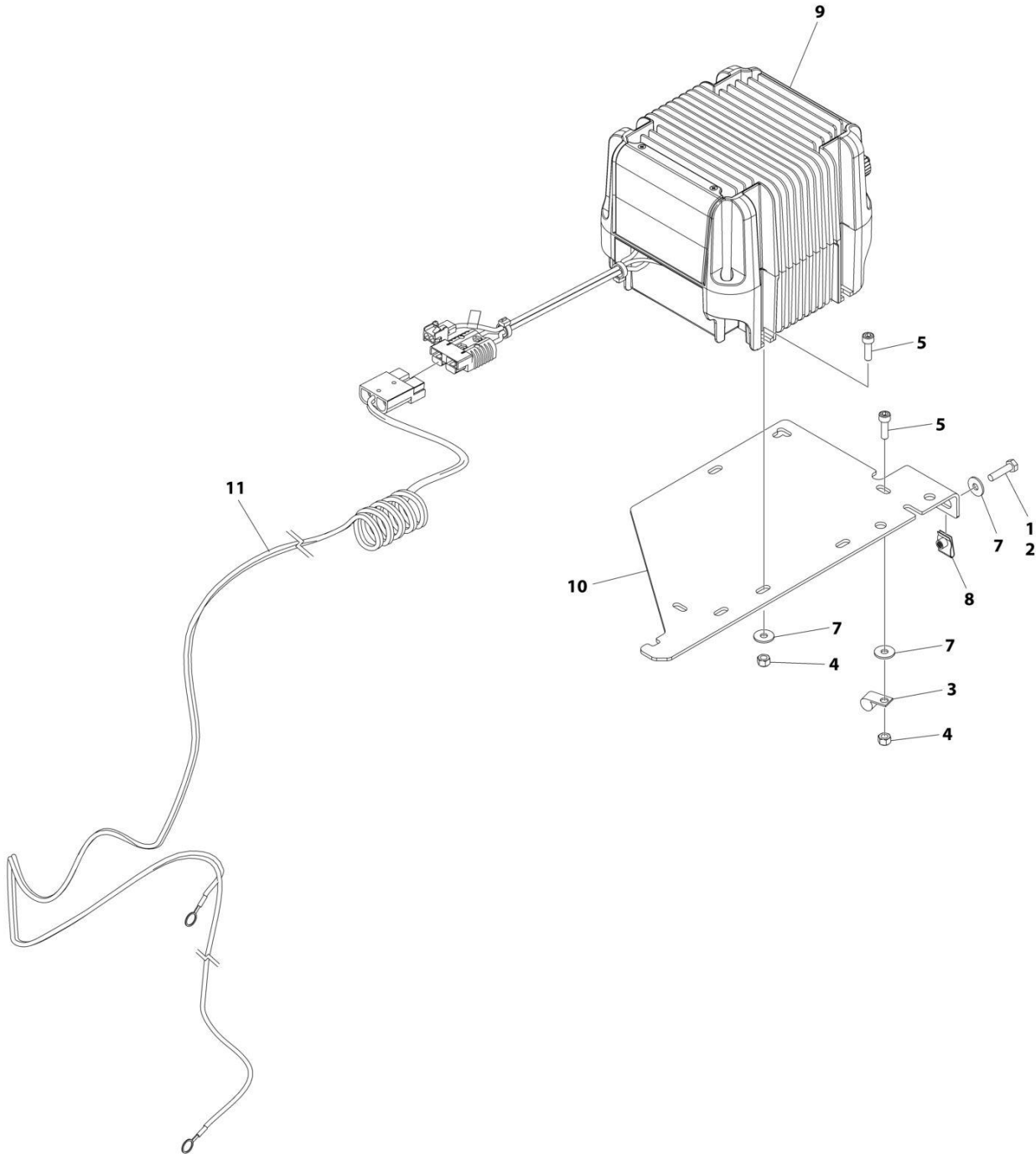

ART_1001263259

SECTION 1 - FRAME

**FIGURE 1-25. BATTERY CHARGER INSTALLATION - GREEN POWER (LOCALLY SUPPLIED PLUG)
(MACHINES WITH SN STARTING WITH B2 & G2) (R1932I/R1932)**

ITEM	PART NUMBER	QTY	DESCRIPTION	REV
	1001263259	Ref	BATTERY CHARGER INSTALLATION - GREEN POWER	A
1	0100011	AR	Compound, Locking	
2	0700612	2	Bolt M6 x 25	
3	1321293	1	Clamp, Cable	
4	3290605	4	Nut M6	
5	4031708	4	Capscrew M6 x 20	
6	4240017	AR	Tie-Strap (Not Shown)	
7	4811702	6	Washer M6	
8	1001130220	2	Nut, Tinnerman M6	
9	1001205598	1	Charger, Battery Green Power	
10	1001236139	1	Bracket	
11	1001256643	1	Charger DC Connection Harness	

SECTION 1 - FRAME

FIGURE 1-26. STROBE LIGHT INSTALLATION - SINGLE SANMAK BRAND (AMBER) (WITH GUARD)

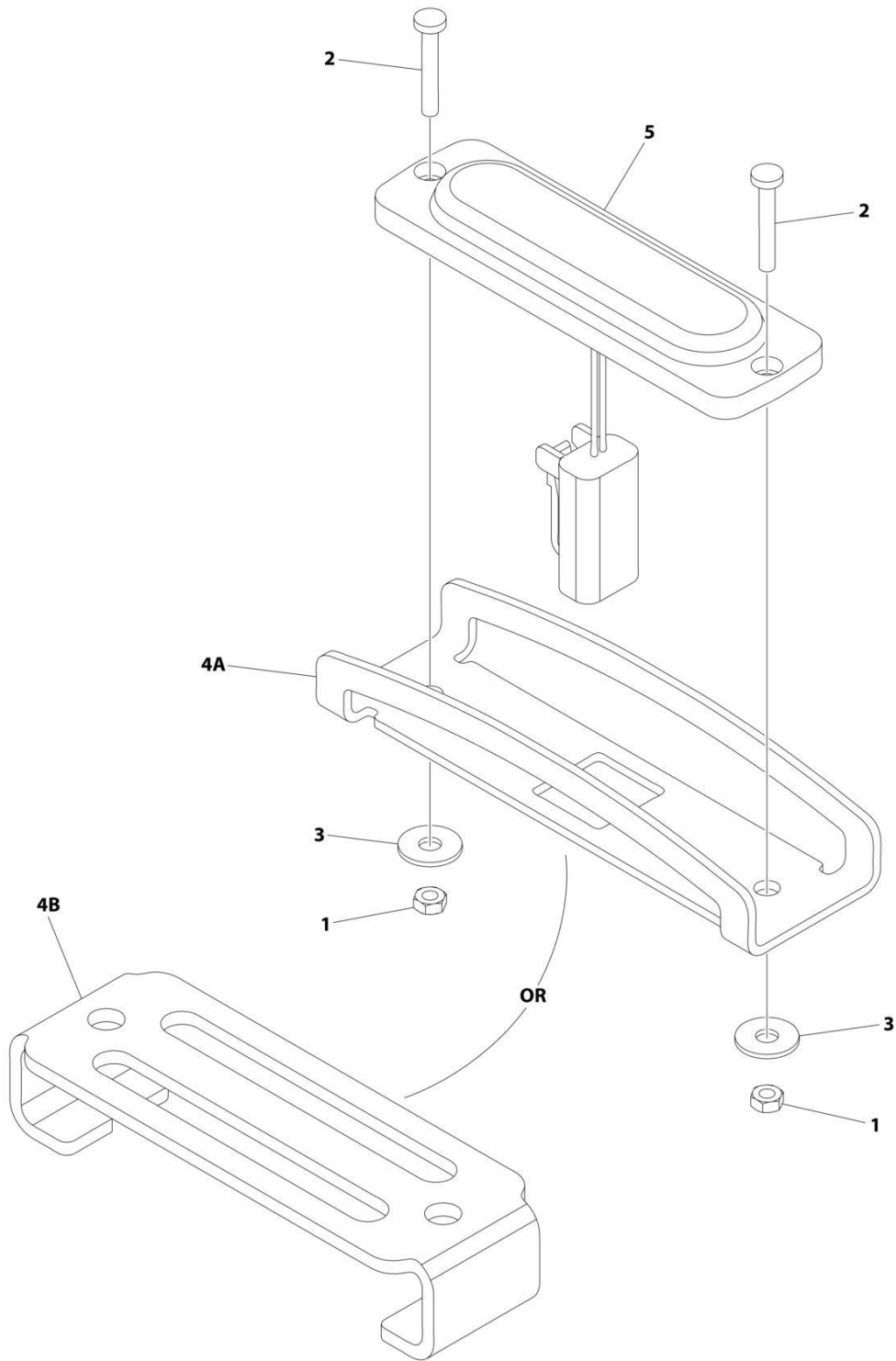

ART_1001242697

SECTION 1 - FRAME

FIGURE 1-26. STROBE LIGHT INSTALLATION - SINGLE SANMAK BRAND (AMBER) (WITH GUARD)

ITEM	PART NUMBER	QTY	DESCRIPTION	REV
	1001242697	Ref	STROBE LIGHT INSTALLATION - SINGLE (AMBER) (WITH GUARD)	D
1	3290305	2	Nut M3	
2	4010310	2	Screw M3 x 20	
3	1001091102	2	Washer M4	
4A	1001242539	1	Guard	
4B	1001239661	1	Cover	
5	1001239224	1	Light, Strobe	
5	4460891	1	Plug, Male - 2 Position	
5	4460465	2	Socket, Female	

SECTION 1 - FRAME

FIGURE 1-27. STROBE LIGHT INSTALLATION - DUAL SANMAK BRAND (AMBER) (WITH GUARD)

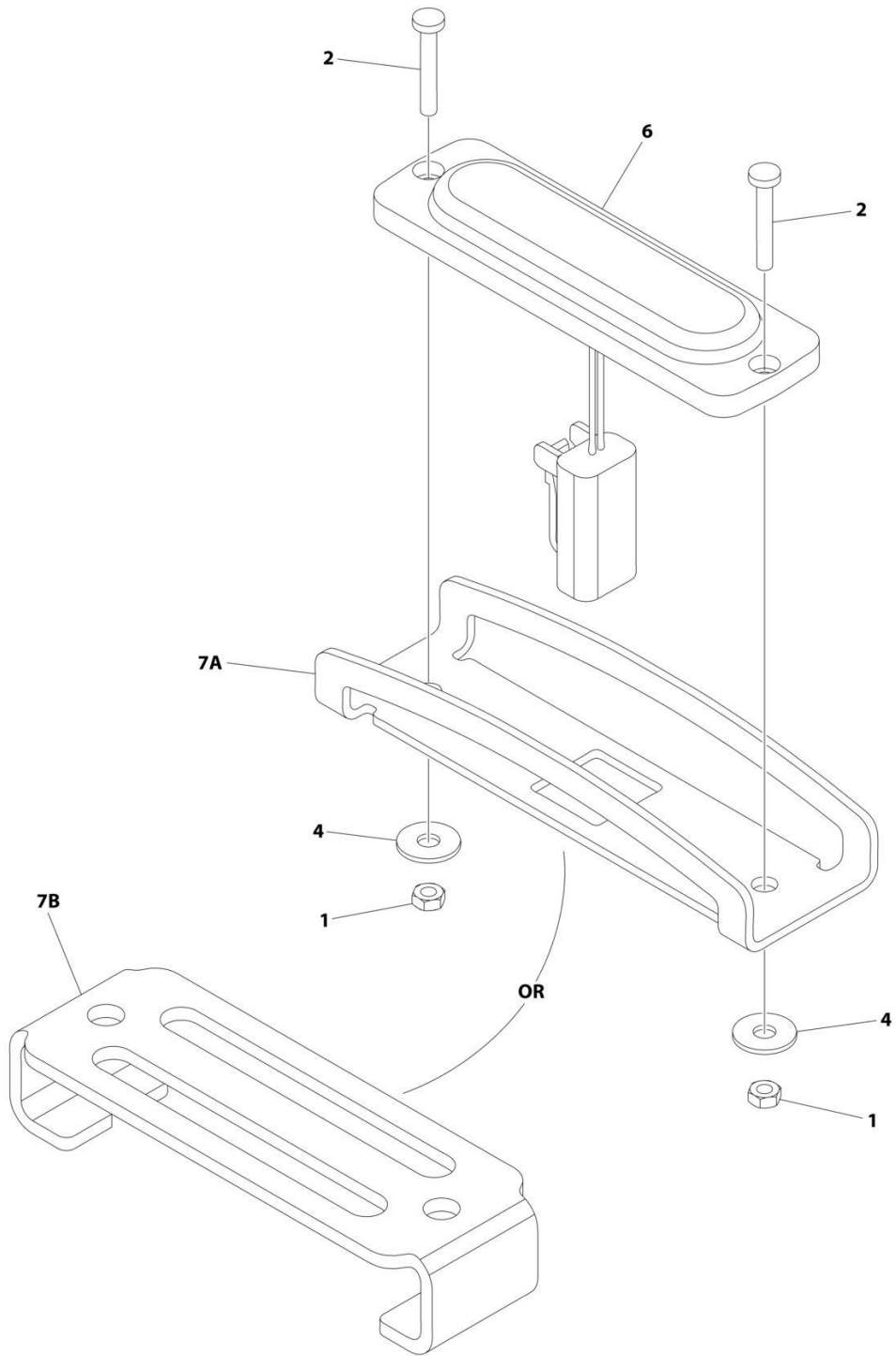

ART_1001247862

SECTION 1 - FRAME

FIGURE 1-27. STROBE LIGHT INSTALLATION - DUAL SANMAK BRAND (AMBER) (WITH GUARD)

ITEM	PART NUMBER	QTY	DESCRIPTION	REV
	1001247862	Ref	STROBE LIGHT INSTALLATION - DUAL (AMBER) (WITH GUARD)	C
1	3290305	4	Nut M3	
2	4010310	4	Screw M3 x 20	
3	4240018	AR	Tie-Strap (Not Shown)	
4	1001091102	4	Washer M4	
5	1001201707	1	Strobe Light Jumper Harness (Not Shown)	
6	1001239224	2	Light, Strobe	
6	4460891	1	Plug, Male - 2 Position	
6	4460465	2	Socket, Female	
7A	1001242539	2	Guard	
7B	1001239661	2	Cover	

SECTION 1 - FRAME

FIGURE 1-28. ALARM INSTALLATION (AMBIENT/WHITE NOISE) (OPTIONAL)

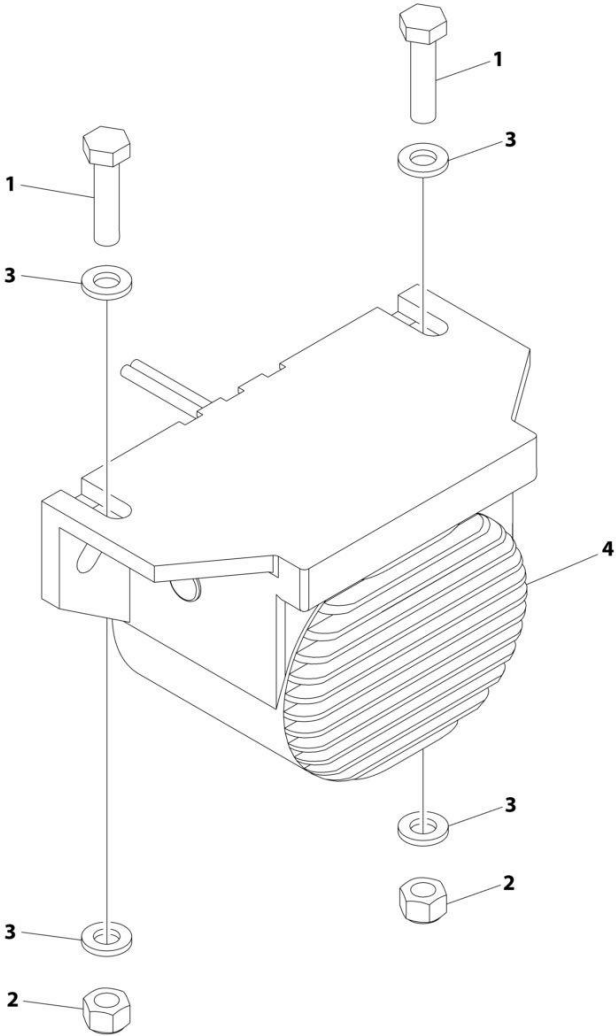

ART_1001204495

SECTION 1 - FRAME

FIGURE 1-28. ALARM INSTALLATION (AMBIENT/WHITE NOISE) (OPTIONAL)

ITEM	PART NUMBER	QTY	DESCRIPTION	REV
	1001204495	Ref	ALARM INSTALLATION (AMBIENT/WHITE NOISE)	B
1	0760612	2	Bolt M6 x 25	
2	3290605	2	Nut M6	
3	4811700	4	Washer M6	
4	1001182806	1	Alarm	
4	4460897	1	Receptacle, Female - 2 Position	
4	4460464	2	Pin, Male	

SECTION 1 - FRAME

FIGURE 1-29. LADDER INSTALLATION

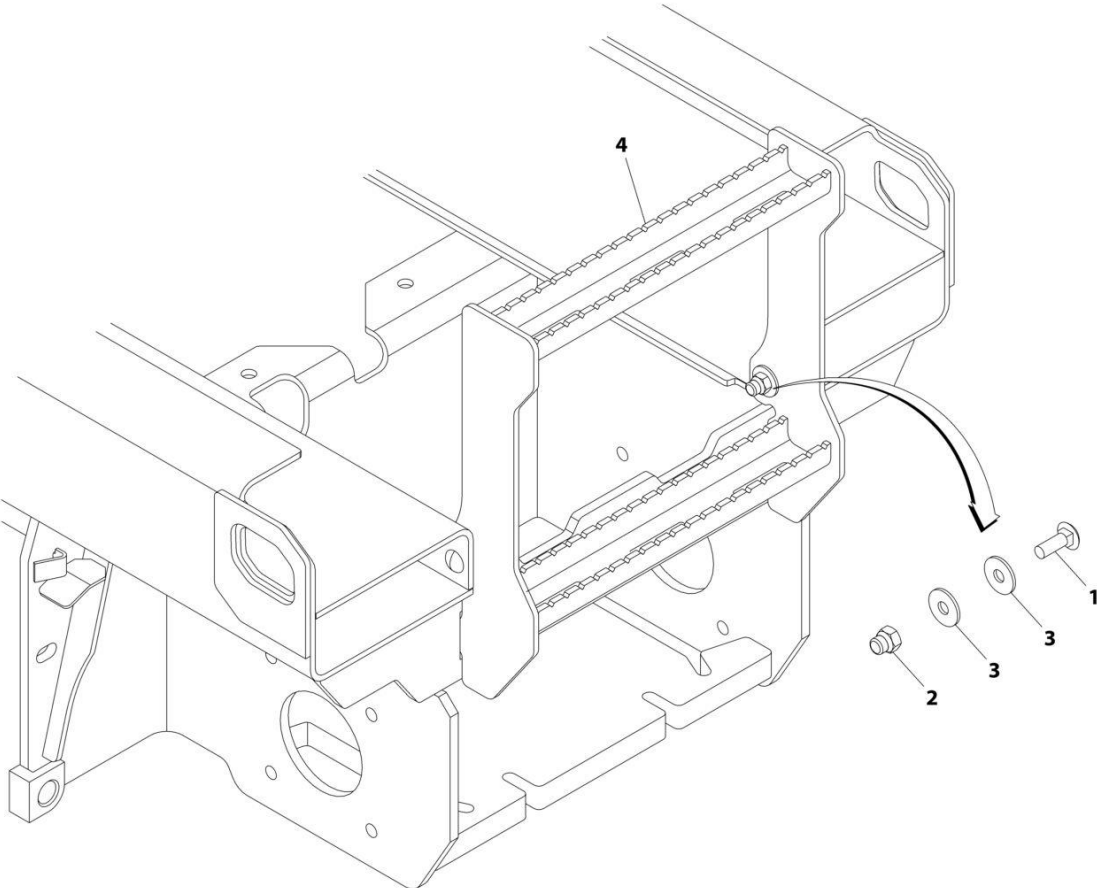

ART_1001203453

FIGURE 1-29. LADDER INSTALLATION

ITEM	PART NUMBER	QTY	DESCRIPTION	REV
	1001203453	Ref	LADDER INSTALLATION	C
1	0630613	2	Bolt M10 x 30	
2	3291006	2	Nut M10	
3	4812002	AR	Washer M10	
4	1001203457	1	Ladder	

SECTION 1 - FRAME

FIGURE 1-30. FRAME COVERS INSTALLATION - FRONT AND REAR (R1532I/R1932I)

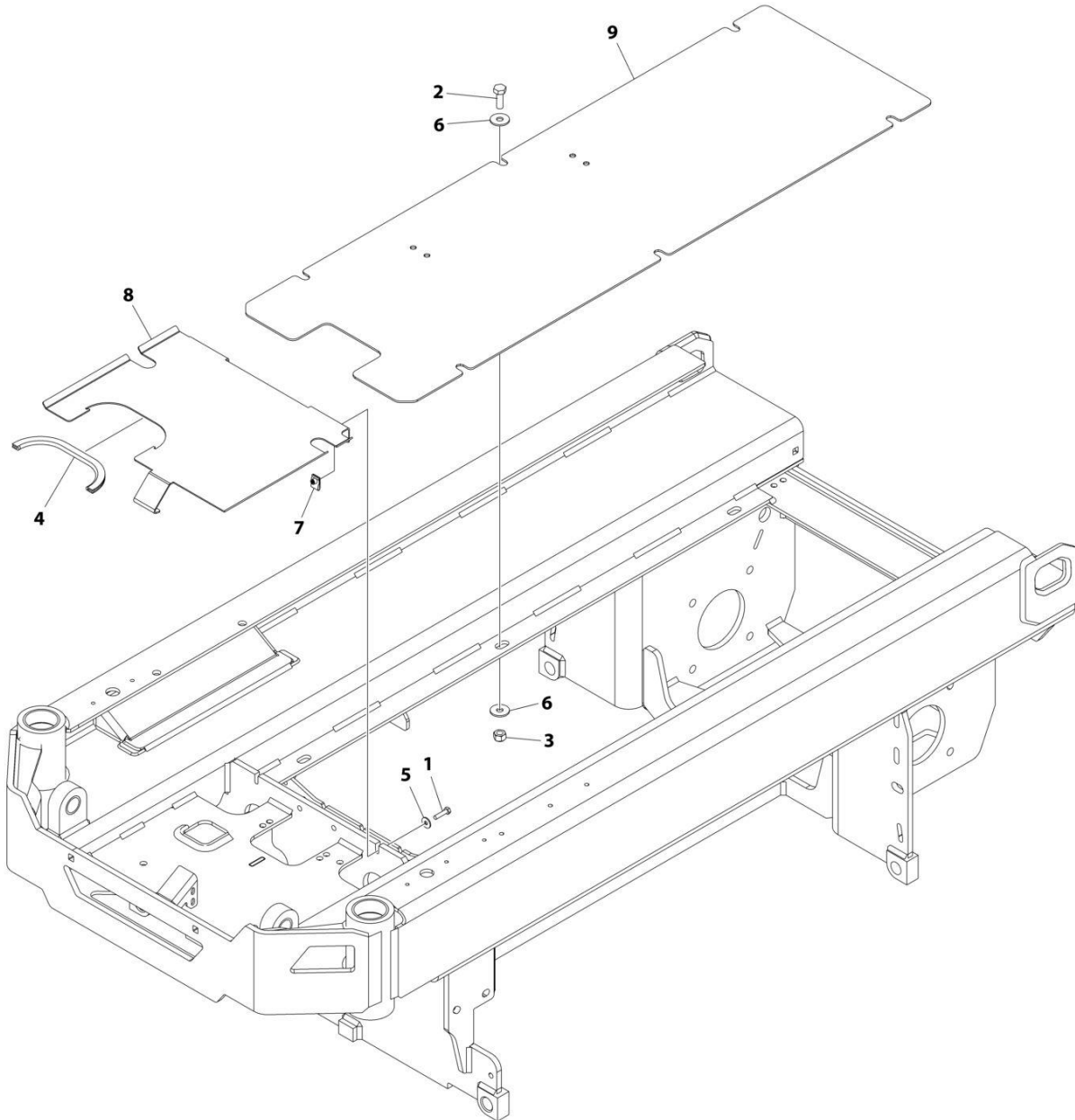

ART_1001253359

SECTION 1 - FRAME

FIGURE 1-30. FRAME COVERS INSTALLATION - FRONT AND REAR (R1532I/R1932I)

ITEM	PART NUMBER	QTY	DESCRIPTION	REV
	1001253359	Ref	FRAME COVERS INSTALLATION	B
1	0700612	2	Bolt M6 x 25	
2	0701014	6	Bolt M10 x 30	
3	3291005	6	Nut M10	
4	4060803	12.99 in /33cm	Flex-Trim	
5	4811702	2	Washer M6	
6	4812002	12	Washer M10	
7	1001130220	2	Nut, Tinnerman M6	
8	1001227966	1	Cover	
9	1001253039	1	Cover	

SECTION 1 - FRAME

FIGURE 1-31. FRAME COVERS INSTALLATION - FRONT (R1932)

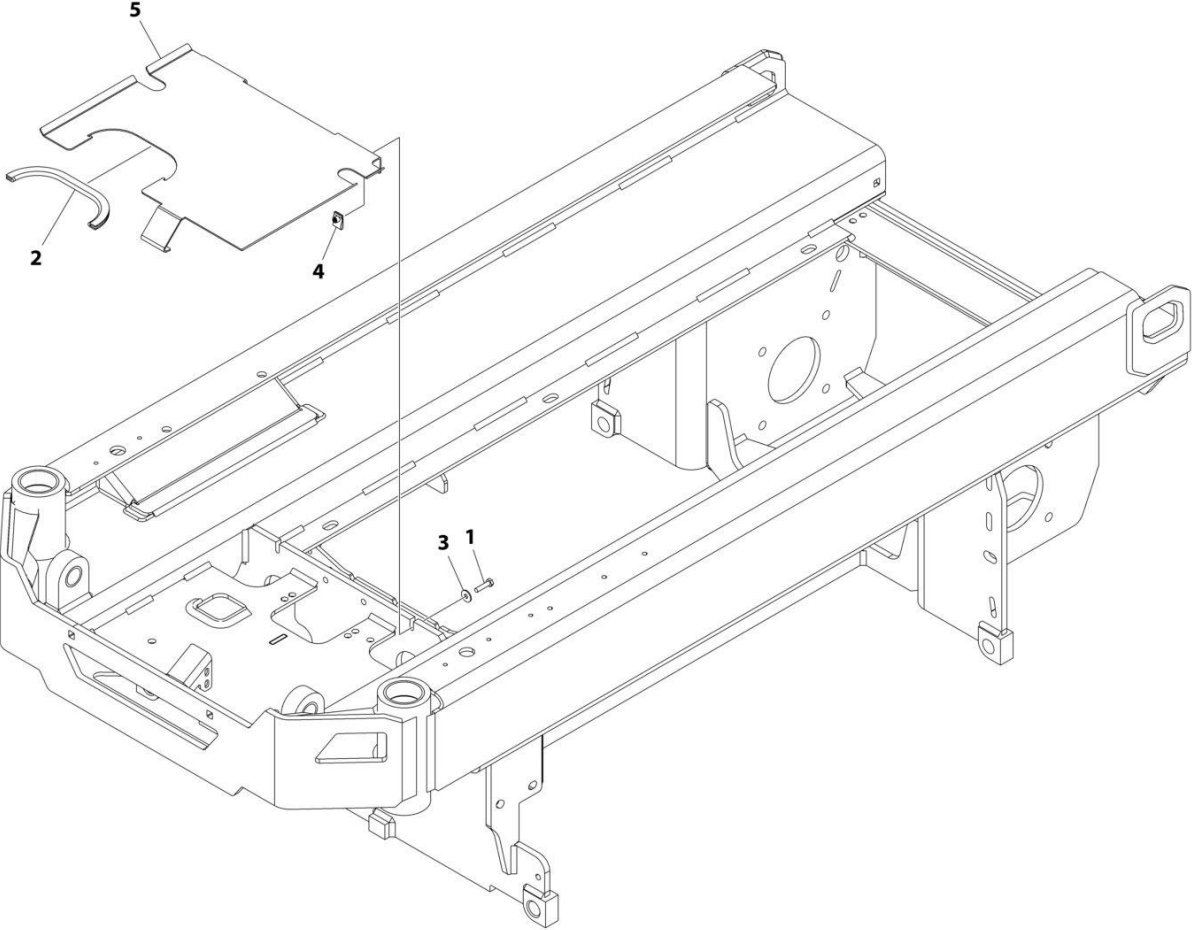

ART_1001250431

SECTION 1 - FRAME

FIGURE 1-31. FRAME COVERS INSTALLATION - FRONT (R1932)

ITEM	PART NUMBER	QTY	DESCRIPTION	REV
	1001250431	Ref	FRAME COVERS INSTALLATION	A
1	0700612	2	Bolt M6 x 25	
2	4060803	12.99 in /33cm	Flex-Trim	
3	4811702	2	Washer M6	
4	1001130220	2	Nut, Tinnerman M6	
5	1001227966	1	Cover	

SECTION 2 - GROUND CONTROLS

SECTION 2 - GROUND CONTROLS

FIGURE 2-1. HYDRAULIC COMPONENTS INSTALLATION (WITH CONCENTRIC PUMP/MOTOR)

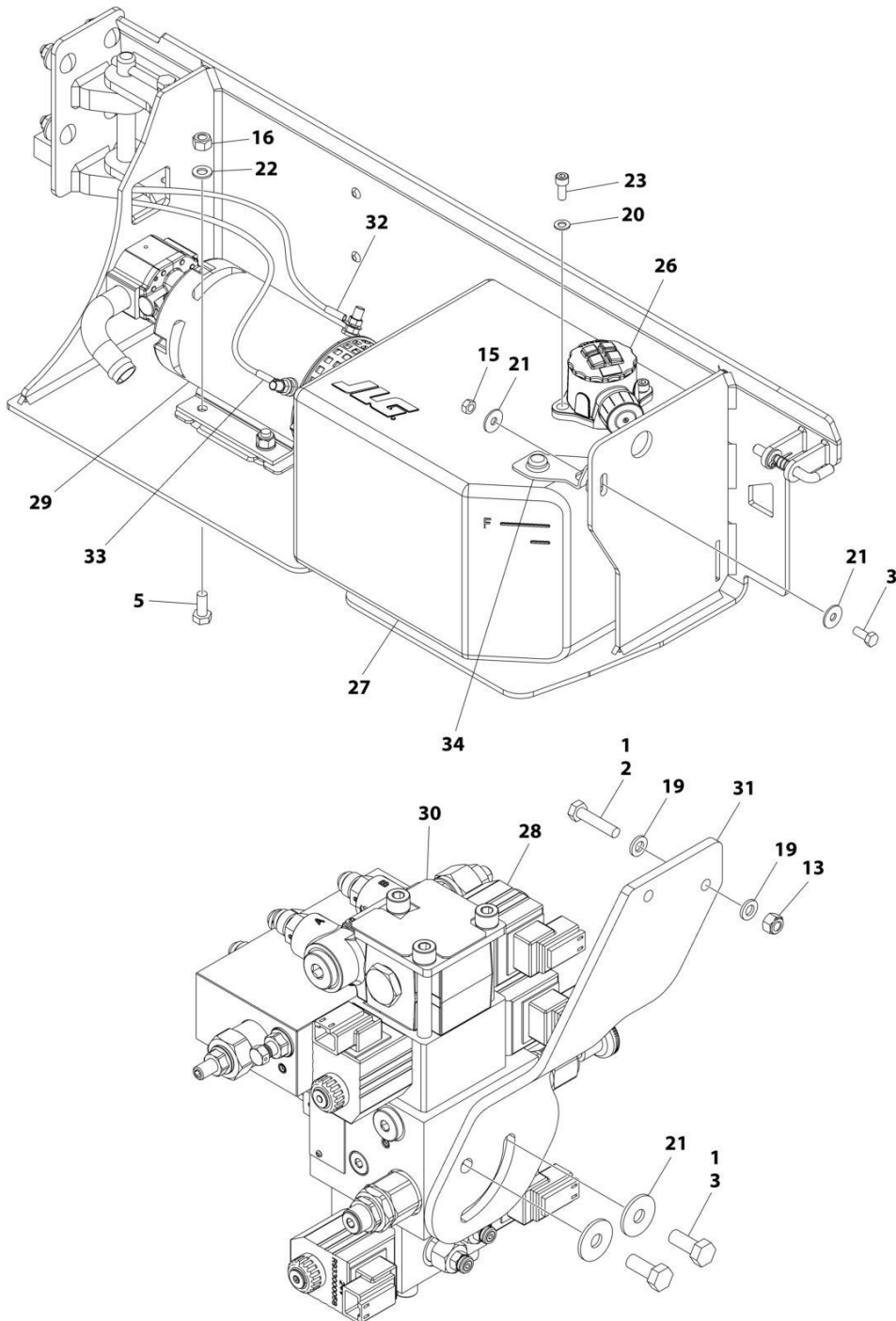

ART_1001253358_C_10F2

SECTION 2 - GROUND CONTROLS

FIGURE 2-1. HYDRAULIC COMPONENTS INSTALLATION (WITH CONCENTRIC PUMP/MOTOR)

ITEM	PART NUMBER	QTY	DESCRIPTION	REV
	1001253358	Ref	HYDRAULIC COMPONENTS INSTALLATION	C
1	0100011	AR	Compound, Locking	
2	0760613	2	Bolt M6 x 28	
3	0760810	3	Bolt M8 x 20	
5	0761012	2	Bolt M10 x 25	
13	3290605	2	Nut M6	
19	4811700	4	Washer M6	
21	4811902	4	Washer M8	
22	4812000	2	Washer M10	
23	5271808	2	Capscrew M8 x 20	
26	1001202851	1	Filter, Hydraulic	
26	70005423	1	Filter Element Kit (Includes Element, Cap O-Ring and Bowl O-Ring)	
26	70007946	1	O-Ring, Bowl	
27	1001203450	1	Tank, Hydraulic	
28	1001204174	1	Valve Assembly (See Separate Breakdown in this Section)	
29	1001204719	1	Motor/Pump Assembly	
29	70005815	1	Replacement Motor	
29	70005817	1	Replacement Pump	
29	70005816	1	Seal and Mounting Kit (Includes Shaft Seal, Retaining Ring, Gasket and Pump Mounting Hardware)	
30	1001212294	1	Decal - Valve Rotate	
31	1001253038	1	Bracket	
32	1001254173	1	Cable, Pump (-)	
33	1001254174	1	Cable, Pump (+)	
34	1001269730	1	Bracket	

SECTION 2 - GROUND CONTROLS

FIGURE 2-2. HYDRAULIC COMPONENTS INSTALLATION (WITH BUCHER PUMP/MOTOR)

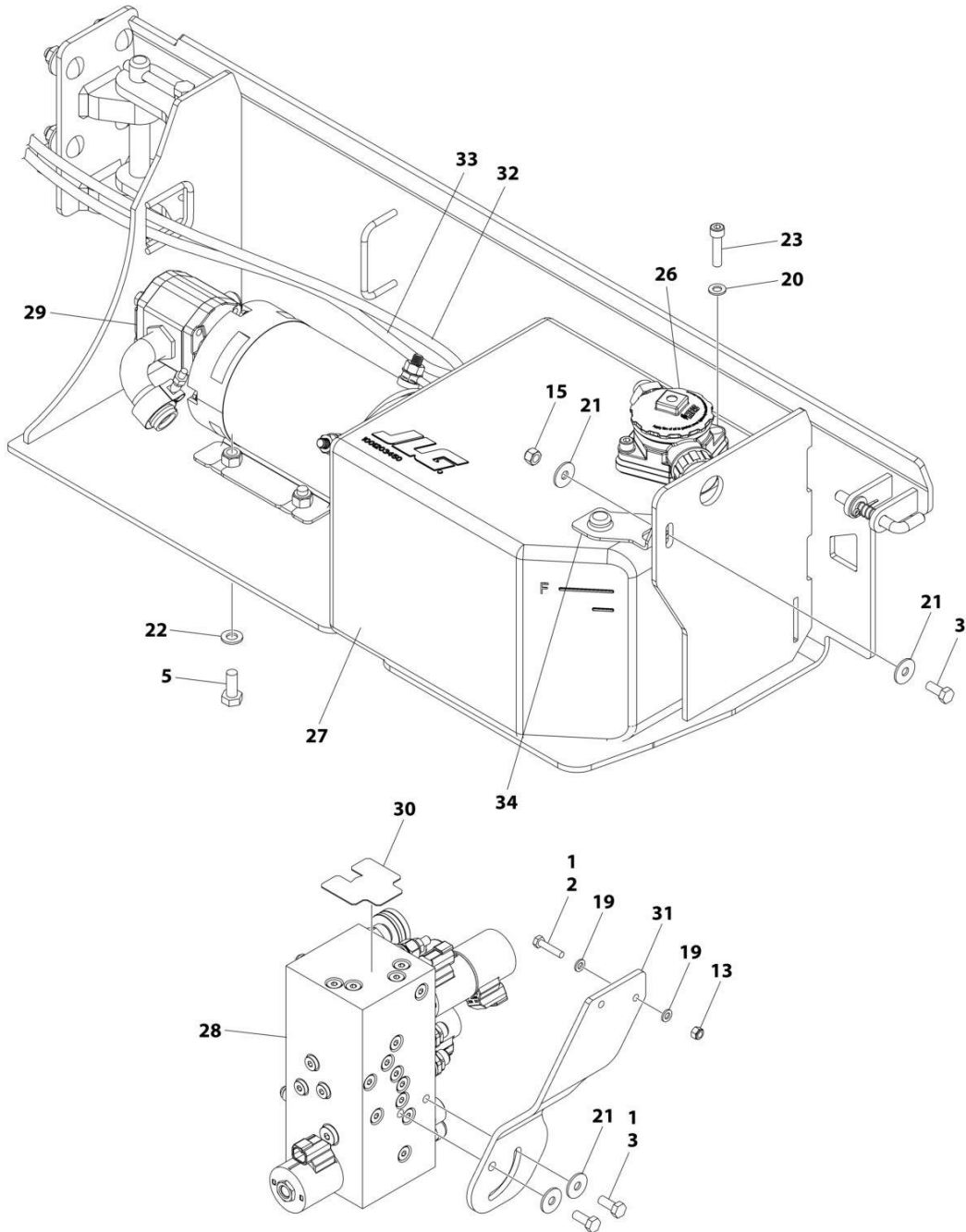

ART_1001276592_10F2

SECTION 2 - GROUND CONTROLS

FIGURE 2-2. HYDRAULIC COMPONENTS INSTALLATION (WITH BUCHER PUMP/MOTOR)

ITEM	PART NUMBER	QTY	DESCRIPTION	REV
	1001276592	Ref	HYDRAULIC COMPONENTS INSTALLATION	A
1	0100011	AR	Compound, Locking	
2	0760613	2	Bolt M6 x 28	
3	0760810	3	Bolt M8 x 20	
5	0761012	2	Bolt M10 x 25	
13	3290605	2	Nut M6	
15	3290805	1	Nut M8	
19	4811700	4	Washer M6	
20	4811900	2	Washer M8	
21	4811902	4	Washer M8	
22	4812000	2	Washer M10	
23	5271811	2	Bolt M8 x 35	
26	1001276711	1	Filter, Hydraulic	
26	70008576	1	Filter Element	
26	70008577	1	Breather	
27	1001203450	1	Tank, Hydraulic	
28	1001276712	1	Valve Assembly (See Separate Breakdown in this Section)	
29	1001269480	1	Motor/Pump Assembly	
29	See Note	1	Replacement Motor (Note: Not Available at Time of Printing)	
29	See Note	1	Replacement Pump (Note: Not Available at Time of Printing)	
29	See Note	1	Seal and Mounting Kit (Note: Not Available at Time of Printing)	
30	1001276713	1	Decal - Manifold	
31	1001253038	1	Bracket	
32	1001254173	1	Cable, Pump (-)	
33	1001254174	1	Cable, Pump (+)	
34	1001269730	1	Bracket	

SECTION 2 - GROUND CONTROLS

FIGURE 2-3. VALVE ASSEMBLY - REXROTH (USED WITH CONCENTRIC PUMP/MOTOR)

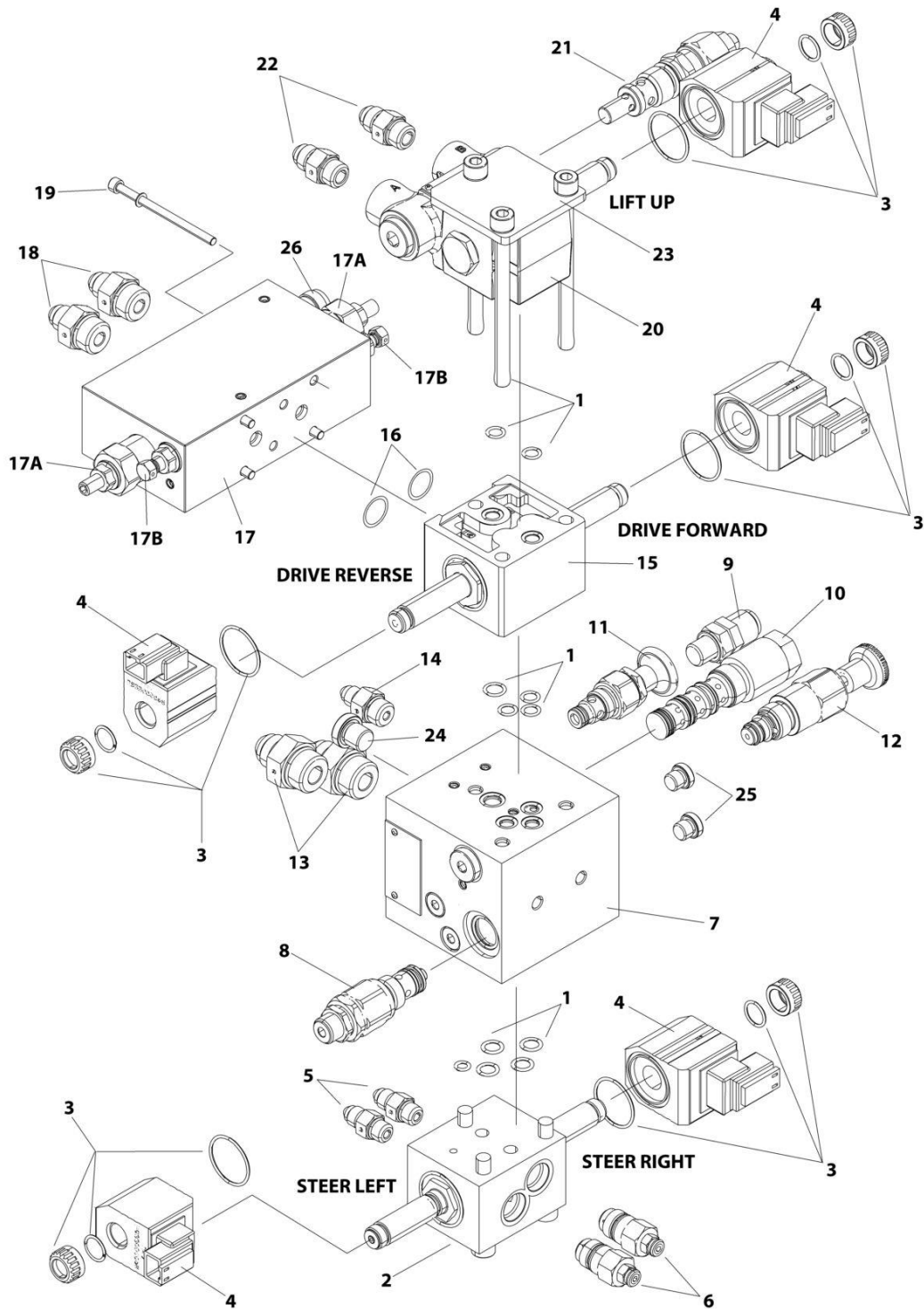

ART_1001204174

SECTION 2 - GROUND CONTROLS

FIGURE 2-3. VALVE ASSEMBLY - REXROTH (USED WITH CONCENTRIC PUMP/MOTOR)

ITEM	PART NUMBER	QTY	DESCRIPTION	REV
	1001204174	Ref	VALVE ASSEMBLY	E
1	70005891	1	Assembly Kit (Includes Assembly Hardware and Seals Between Valve Blocks)	
2	70005892	1	Valve Assembly Less Coils (Steer)	
3	70021209	5	Coil Retainer Kit	
4	70005893	5	Coil	
5	2220415	2	Fitting, Straight	
6	70005895	2	Valve, Cartridge (Steer)	
7	See Note	NSS	Block, Valve (Entry Valve) (Note: Use p/n 1001204174)	
8	70005896	1	Valve, Cartridge	
9	2221086	1	Fitting, Hydraulic Test	
10	70005898	1	Valve, Cartridge	
11	70005899	1	Valve, Cartridge	
12	70005900	1	Valve, Cartridge	
13	2220374	2	Fitting, Straight JIC/ORB	
14	2220582	1	Fitting, Straight JIC/ORB	
15	70005903	1	Valve Assembly Less Coils (Lower Drive Valve)	
16	70005904	1	Seal Kit	
17	70005905	1	Valve Assembly (Upper Drive Valve)	
17A	See Note	NSS	Valve, Cartridge (Note: Use p/n 70005905)	
17B	See Note	NSS	Valve, Cartridge (Note: Use p/n 70005905)	
18	2220372	2	Fitting, Straight JIC/ORB	
19	70005907	1	Hardware Kit - Valve Mounting	
20	70005908	1	Valve Assembly Less Coil (Lift)	
21	70005909	1	Valve, Cartridge	
22	2220371	2	Fitting, Straight JIC/ORB	
23	70005911	1	Plate, End	
24	70005912	1	Plug	
25	70005913	2	Plug	
26	70005914	1	Valve, Cartridge	

SECTION 2 - GROUND CONTROLS

FIGURE 2-4. VALVE ASSEMBLY - STANT (USED WITH BUCHER PUMP/MOTOR)

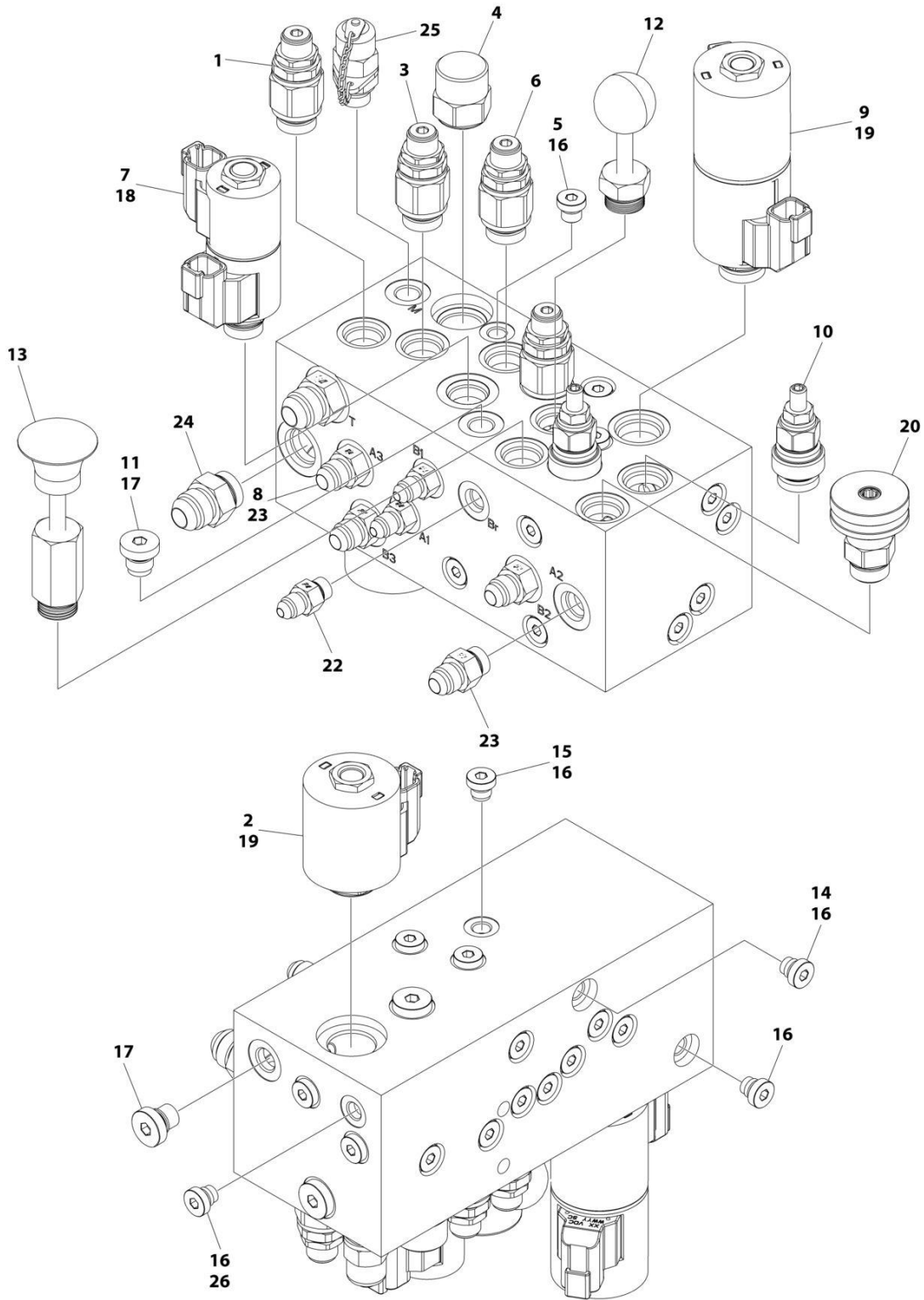

ART_1001276712

SECTION 2 - GROUND CONTROLS

FIGURE 2-4. VALVE ASSEMBLY - STANT (USED WITH BUCHER PUMP/MOTOR)

ITEM	PART NUMBER	QTY	DESCRIPTION	REV
	1001276712	Ref	VALVE ASSEMBLY	A
		Ref	Note: No Other Service Parts Available at Time of Printing.	
1		Ref	Valve, Cartridge - Relief	
2	8036580	1	Valve, Solenoid Cartridge (Less Coil)	
3		Ref	Valve, Cartridge - Relief	
4		Ref	Valve, Cartridge	
5		Ref	Orifice	
6		Ref	Valve, Cartridge - Relief	
7		Ref	Valve, Cartridge	
8		Ref	Orifice	
9	7017470	1	Valve, Solenoid Cartridge (Less Coil)	
10		Ref	Valve, Cartridge - Counter Balance	
11		Ref	Valve, Cartridge - Check	
12		Ref	Valve, Cartridge	
13		Ref	Pump, Hand	
14		Ref	Valve, Cartridge - Check	
15		Ref	Orifice	
16		Ref	Plug	
17		Ref	Plug	
18		Ref	Coil	
19		Ref	Coil	
20		Ref	Valve, Cartridge	
21		Ref	Orifice (Not Shown)	
22		Ref	Fitting, Straight	
23		Ref	Fitting, Straight	
24		Ref	Fitting, Straight	
25		Ref	Fitting, Test	
26		Ref	Orifice	

SECTION 2 - GROUND CONTROLS

FIGURE 2-5. ELECTRICAL COMPONENTS INSTALLATION (MACHINES WITH SN STARTING WITH B2 & M2)

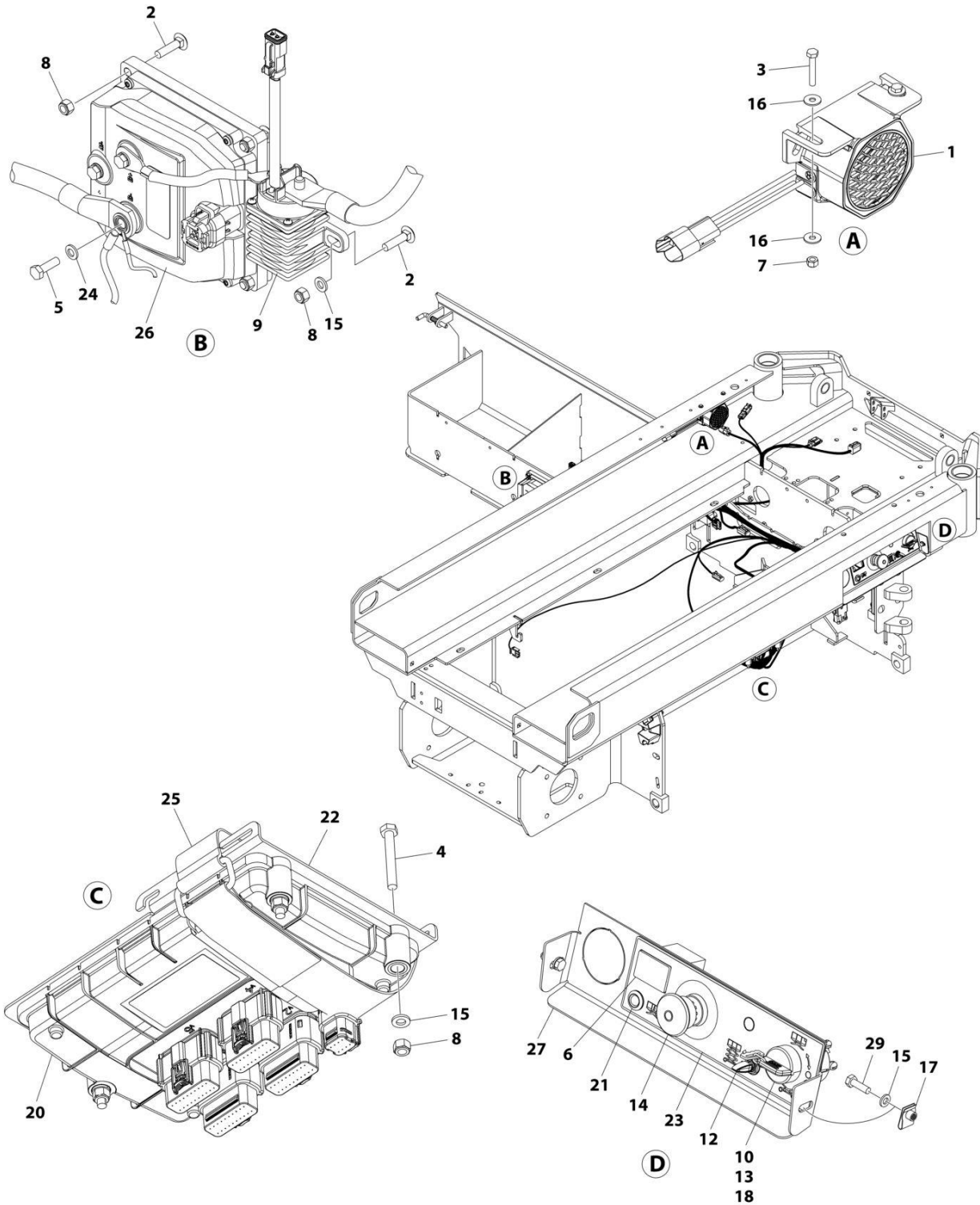

ART_1001254444_E

SECTION 2 - GROUND CONTROLS

FIGURE 2-5. ELECTRICAL COMPONENTS INSTALLATION (MACHINES WITH SN STARTING WITH B2 & M2)

ITEM	PART NUMBER	QTY	DESCRIPTION	REV
	1001254444	Ref	ELECTRICAL COMPONENTS INSTALLATION	E
1	0140043	1	Alarm	
2	0630587	4	Bolt M6 x 25	
3	0700412	2	Bolt M4 x 25	
4	0700617	3	Bolt M6 x 45	
5	0760610	3	Bolt M6 x 20	
6	2420172	1	Hourmeter	
7	3290405	2	Nut M4	
8	3290605	7	Nut M6	
9	3740150	1	Relay	
10	3910804	3	Screw #8 x 1/4	
11	4240017	AR	Tie-Strap (Not Shown)	
12	4360328	1	Switch, Toggle	
13	4360469	1	Switch, Key	
13	2860030	1 Set	Key, Replacement	
14	4360475	1	Switch, Emergency Stop (Metal)	
14	7020175	1	Cap	
14	7020176	1	Block, Contact	
14	1001274559	1	Switch, Emergency Stop (Plastic)	
15	4811700	7	Washer M6	
16	1001091102	4	Washer M4	
17	1001130220	2	Nut, Tinnerman M6	
18	1001130590	1	Plate, Key Switch	
19	1001187781	1	Tie-Strap (Not Shown)	
20	1001200629	1	Module, Control (Note: Re-calibration Required when Replaced)	
21	1001200631	1	Lamp	
22	1001207494	1	Bracket	
23	1001209682	1	Decal - Ground Control	
24	1001210966	3	Washer	
25	1001215762	1	Strap, Cinch	
26	1001216062	1	Module, Power (Note: Re-calibration Required when Replaced)	
27	1001235559	1	Support	
28	1001283408	1	Chassis Harness (Not Shown - See Separate Breakdown in ELECTRICAL SECTION)	
29	0760608	2	Bolt M6 x 16	

SECTION 2 - GROUND CONTROLS

FIGURE 2-6. ELECTRICAL COMPONENTS INSTALLATION (MACHINES WITH SN STARTING WITH 12)

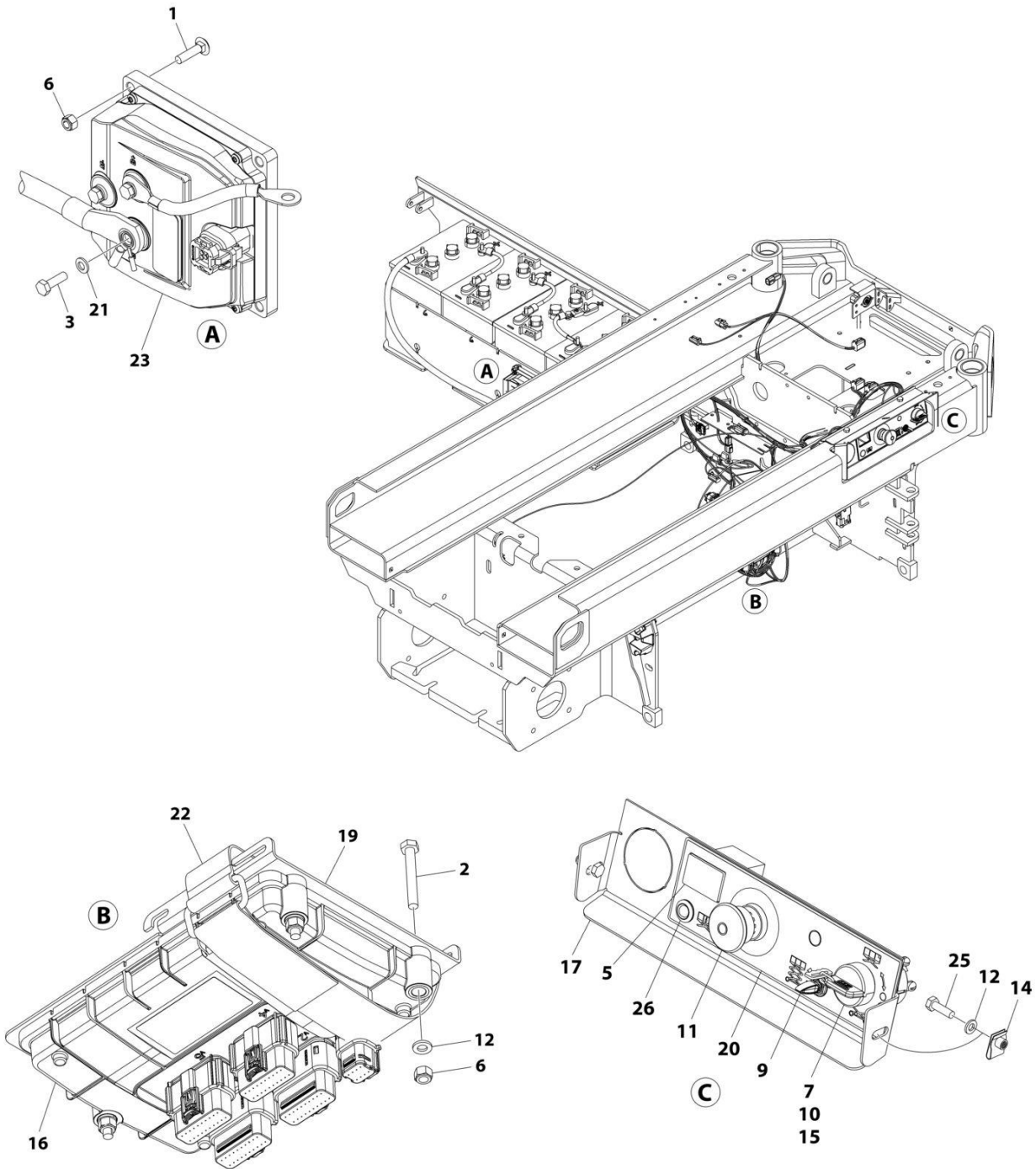

ART_1001253871

SECTION 2 - GROUND CONTROLS

FIGURE 2-6. ELECTRICAL COMPONENTS INSTALLATION (MACHINES WITH SN STARTING WITH 12)

ITEM	PART NUMBER	QTY	DESCRIPTION	REV
	1001253871	Ref	ELECTRICAL COMPONENTS INSTALLATION	C
1	0630587	4	Bolt M6 x 25	
2	0700617	3	Bolt M6 x 45	
3	0760610	3	Bolt M6 x 20	
5	2420172	1	Hourmeter	
6	3290605	5	Nut M6	
7	3910804	3	Screw #8 x 1/4	
8	4240017	AR	Tie-Strap (Not Shown)	
9	4360328	1	Switch, Toggle	
10	4360469	1	Switch, Key	
10	2860030	1 Set	Key, Replacement	
11	4360475	1	Switch, Emergency Stop (Metal)	
11	7020175	1	Cap	
11	7020176	1	Block, Contact	
11	1001274559	1	Switch, Emergency Stop (Plastic)	
12	4811700	5	Washer M6	
14	1001130220	2	Nut, Tinnerman M6	
15	1001130590	1	Plate, Key Switch	
16	1001200629	1	Module, Control (Note: Re-calibration Required when Replaced)	
17	1001235559	1	Support	
19	1001207494	1	Bracket	
20	1001209682	1	Decal - Ground Control	
21	1001210966	3	Washer	
22	1001215762	1	Strap, Cinch	
23	1001216062	1	Module, Power (Note: Re-calibration Required when Replaced)	
25	0760608	2	Bolt M6 x 16	
26	1001200631	1	Lamp	

SECTION 2 - GROUND CONTROLS

FIGURE 2-7. ELECTRICAL COMPONENTS INSTALLATION (MACHINES WITH SN STARTING WITH G2)

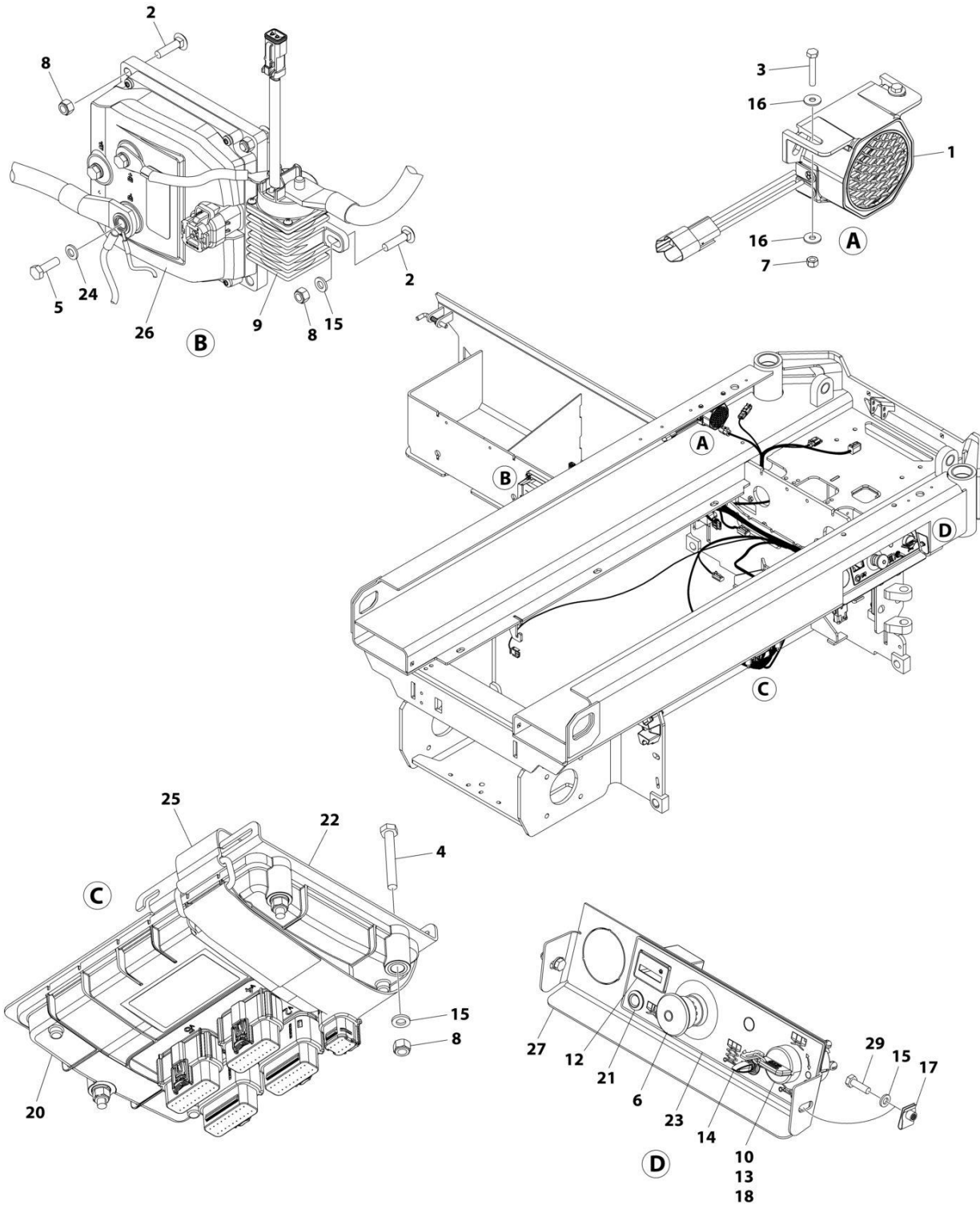

ART_1001276600

SECTION 2 - GROUND CONTROLS

FIGURE 2-7. ELECTRICAL COMPONENTS INSTALLATION (MACHINES WITH SN STARTING WITH G2)

ITEM	PART NUMBER	QTY	DESCRIPTION	REV
	1001276600	Ref	GROUND CONTROL INSTALLATION	C
1	0140043	1	Alarm	
2	0630587	4	Bolt M6 x 25	
3	0700412	2	Bolt M4 x 25	
4	0700617	3	Bolt M6 x 45	
5	0760610	3	Bolt M6 x 20	
6	1001274559	1	Switch, Emergency Stop	
7	3290405	2	Nut M4	
8	3290605	7	Nut M6	
9	3740150	1	Relay	
10	3910804	3	Screw #8 x 1/4	
11	4240017	AR	Tie-Strap (Not Shown)	
12	1001276659	1	Gauge, Hourmeter	
13	4360469	1	Switch, Key	
14	1001276738	1	Switch	
15	4811700	7	Washer M6	
16	1001091102	4	Washer M4	
17	1001130220	2	Nut, Tinnerman M6	
18	1001130590	1	Plate, Key Switch	
19	1001187781	1	Tie-Strap (Not Shown)	
20	1001200629	1	Module, Control (Note: Re-calibration Required when Replaced)	
21	1001276740	1	Lamp	
22	1001207494	1	Bracket	
23	1001209682	1	Decal - Ground Control	
24	1001210966	3	Washer	
25	1001276979	1	Strap	
26	1001216062	1	Module, Power (Note: Re-calibration Required when Replaced)	
27	1001235559	1	Support	
28	1001283408	1	Chassis Harness (Not Shown - See Separate Breakdown in ELECTRICAL Section)	
29	0760608	2	Bolt M6 x 16	

SECTION 2 - GROUND CONTROLS

FIGURE 2-8. MDI INSTALLATION

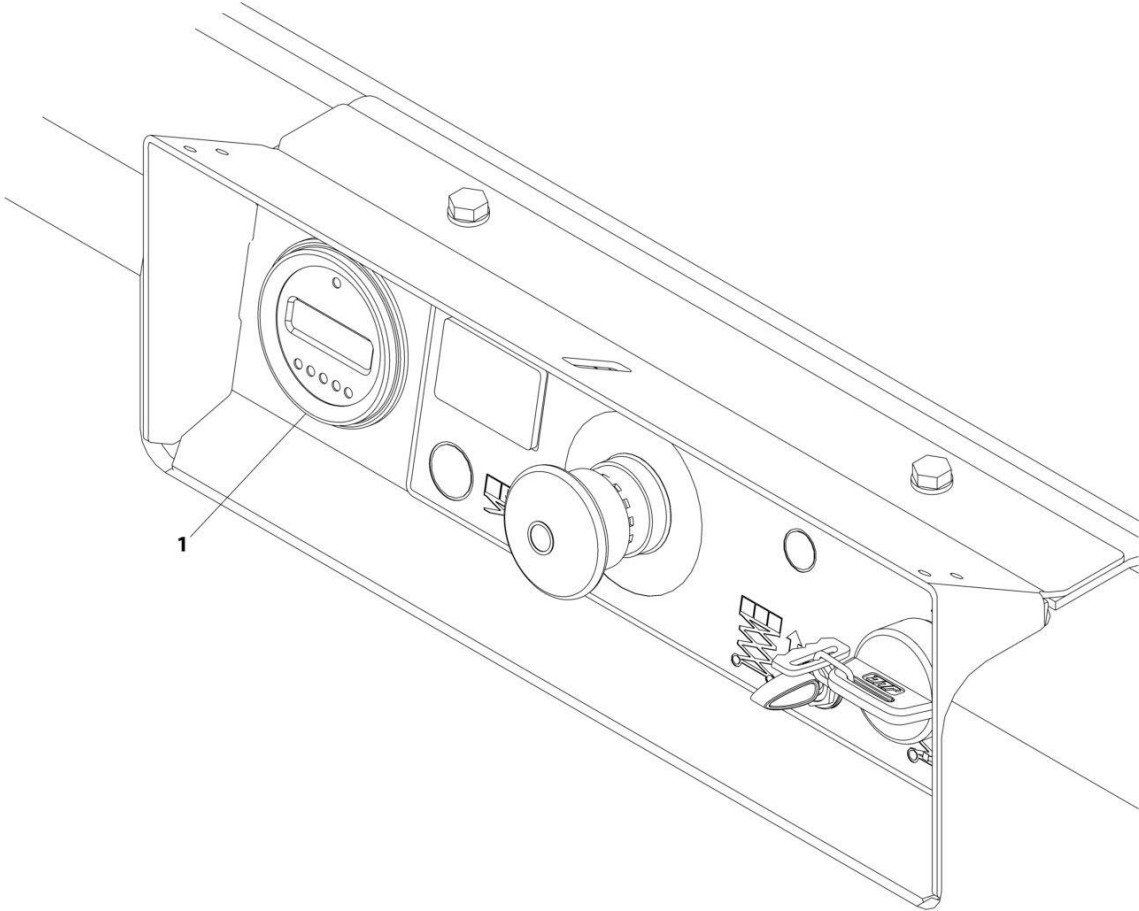

ART_1001207293

SECTION 2 - GROUND CONTROLS

FIGURE 2-8. MDI INSTALLATION

ITEM	PART NUMBER	QTY	DESCRIPTION	REV
1	1001207293 1001200632	Ref 1	MDI INSTALLATION Gauge, MDI	B

SECTION 2 - GROUND CONTROLS

FIGURE 2-9. BATTERIES INSTALLATION - STANDARD BATTERIES WITH DISCONNECT

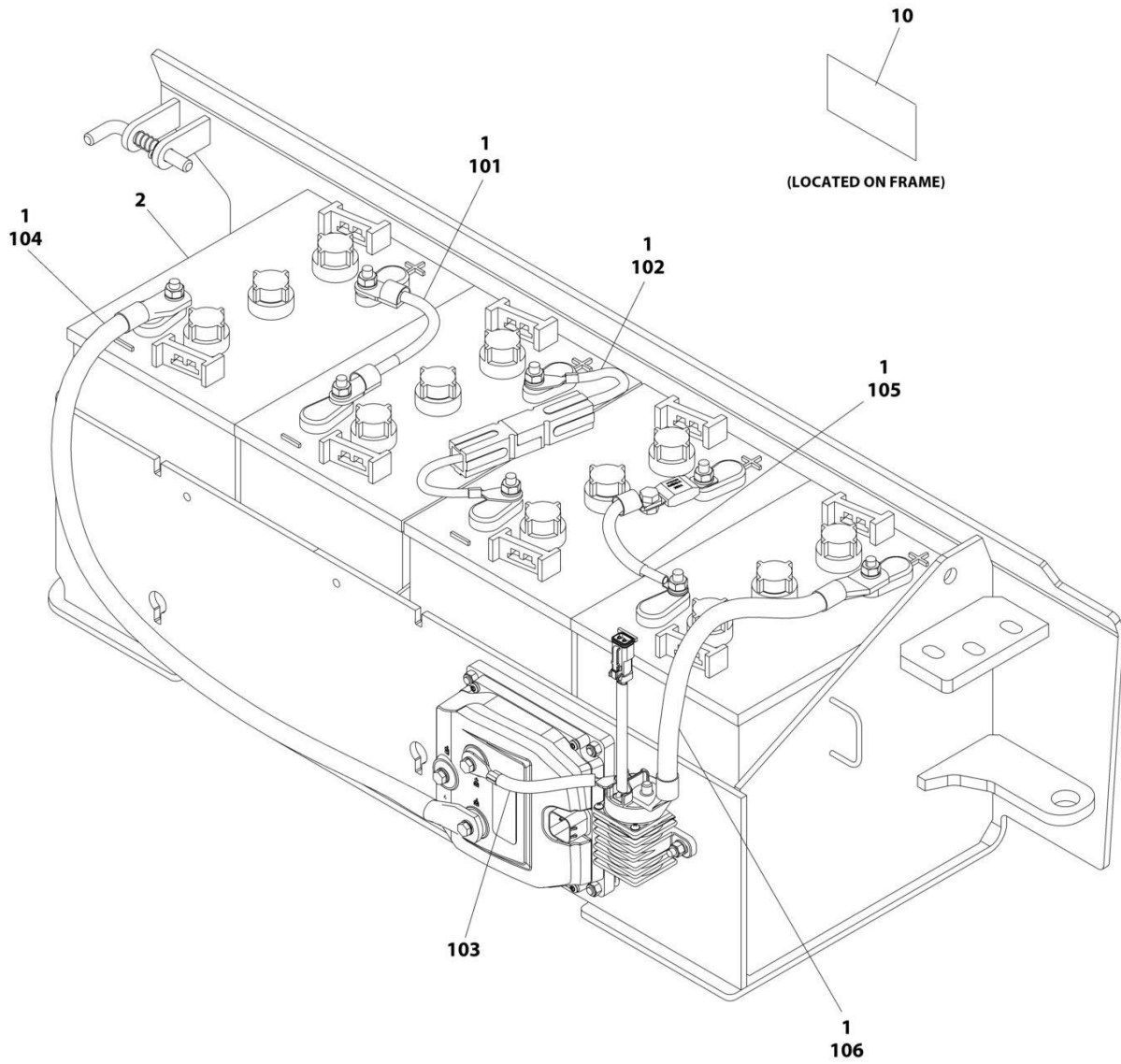

ART_1001208057_F

SECTION 2 - GROUND CONTROLS

FIGURE 2-9. BATTERIES INSTALLATION - STANDARD BATTERIES WITH DISCONNECT

ITEM	PART NUMBER	QTY	DESCRIPTION	REV
	1001208057	Ref	BATTERIES INSTALLATION - STANDARD BATTERIES WITH DISCONNECT	F
1	0100051	AR	Grease, Terminal	
2	1001216180	4	Battery	
9	4240017	AR	Tie-Strap (Not Shown)	
10	1702155	1	Decal - Battery Disconnect	
100	1001228123	1	Battery Cable Kit (Not Shown)	A
101	1060998	2	Cable, Positive to Negative	
102	4923328	1	Cable, Positive to Negative	
103	1001201708	1	Cable, Contactor to Pump Control B+	
104	1001201711	1	Cable, Battery Negative to Pump Control B-	
105	1001210401	1	Cable, Battery Fuse	
106	1001229110	1	Cable, Battery Positive to Contactor	

SECTION 2 - GROUND CONTROLS

FIGURE 2-10. BATTERIES INSTALLATION - AGM BATTERIES WITH DISCONNECT (MACHINES WITH SN STARTING WITH M2)

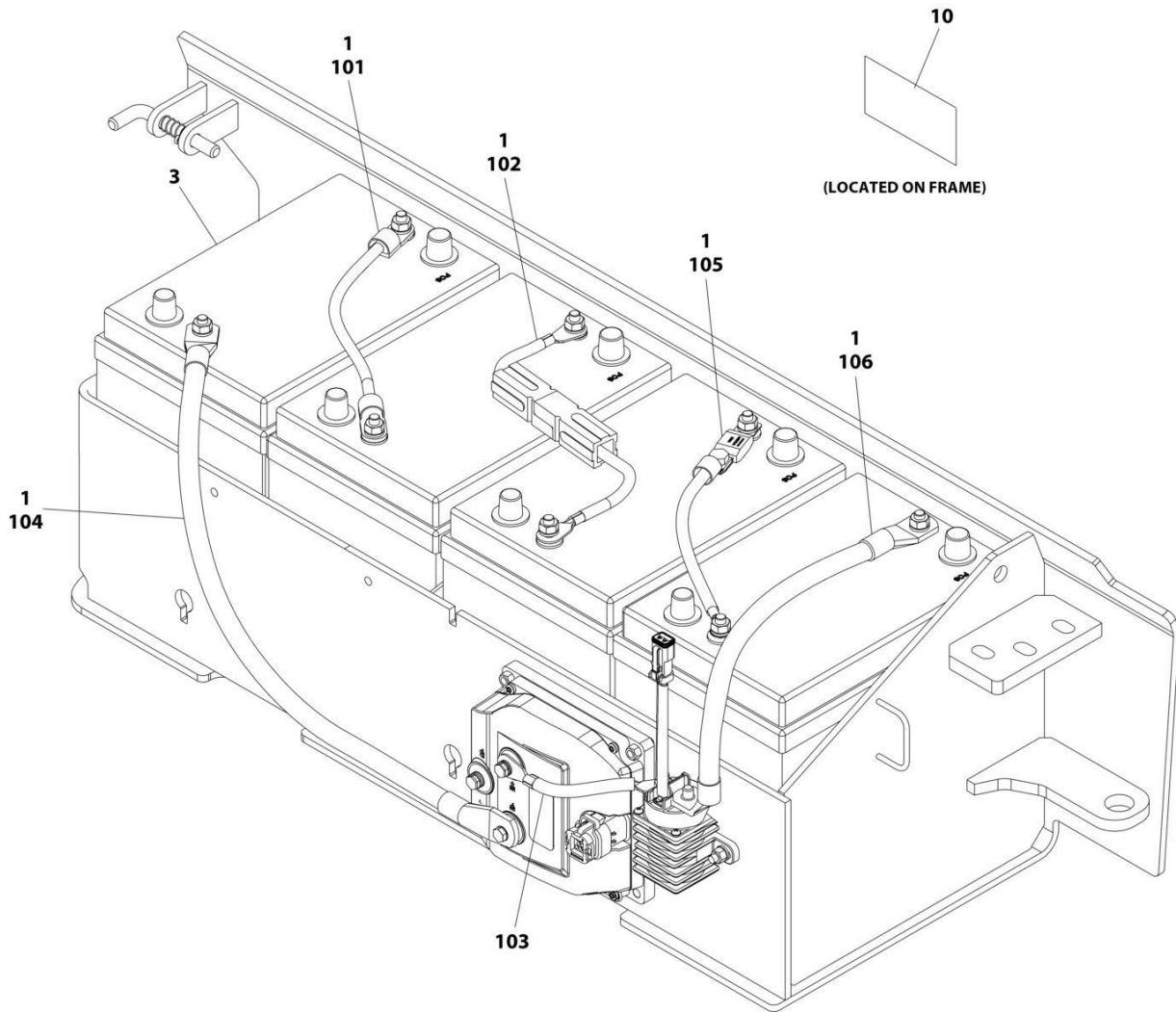

ART_1001208058_F

SECTION 2 - GROUND CONTROLS

FIGURE 2-10. BATTERIES INSTALLATION - AGM BATTERIES WITH DISCONNECT (MACHINES WITH SN STARTING WITH M2)

ITEM	PART NUMBER	QTY	DESCRIPTION	REV
	1001208058	Ref	BATTERIES INSTALLATION - AGM BATTERIES WITH DISCONNECT (MACHINES WITH SN STARTING WITH M2)	F
1	0100051	AR	Grease, Terminal	
3	1001112112	4	Battery	
9	4240017	AR	Tie-Strap (Not Shown)	
10	1702155	1	Decal - Battery Disconnect	
100	1001228123	1	Battery Cable Kit (Not Shown)	A
101	1060998	2	Cable, Positive to Negative	
102	4923328	1	Cable, Positive to Negative	
103	1001201708	1	Cable, Contactor to Pump Control B+	
104	1001201711	1	Cable, Battery Negative to Pump Control B-	
105	1001210401	1	Cable, Battery Fuse	
106	1001229110	1	Cable, Battery Positive to Contactor	

SECTION 2 - GROUND CONTROLS

FIGURE 2-11. BATTERIES INSTALLATION - AGM EVCG BATTERIES WITH DISCONNECT
(MACHINES WITH SN STARTING WITH 12, B2 & G2)

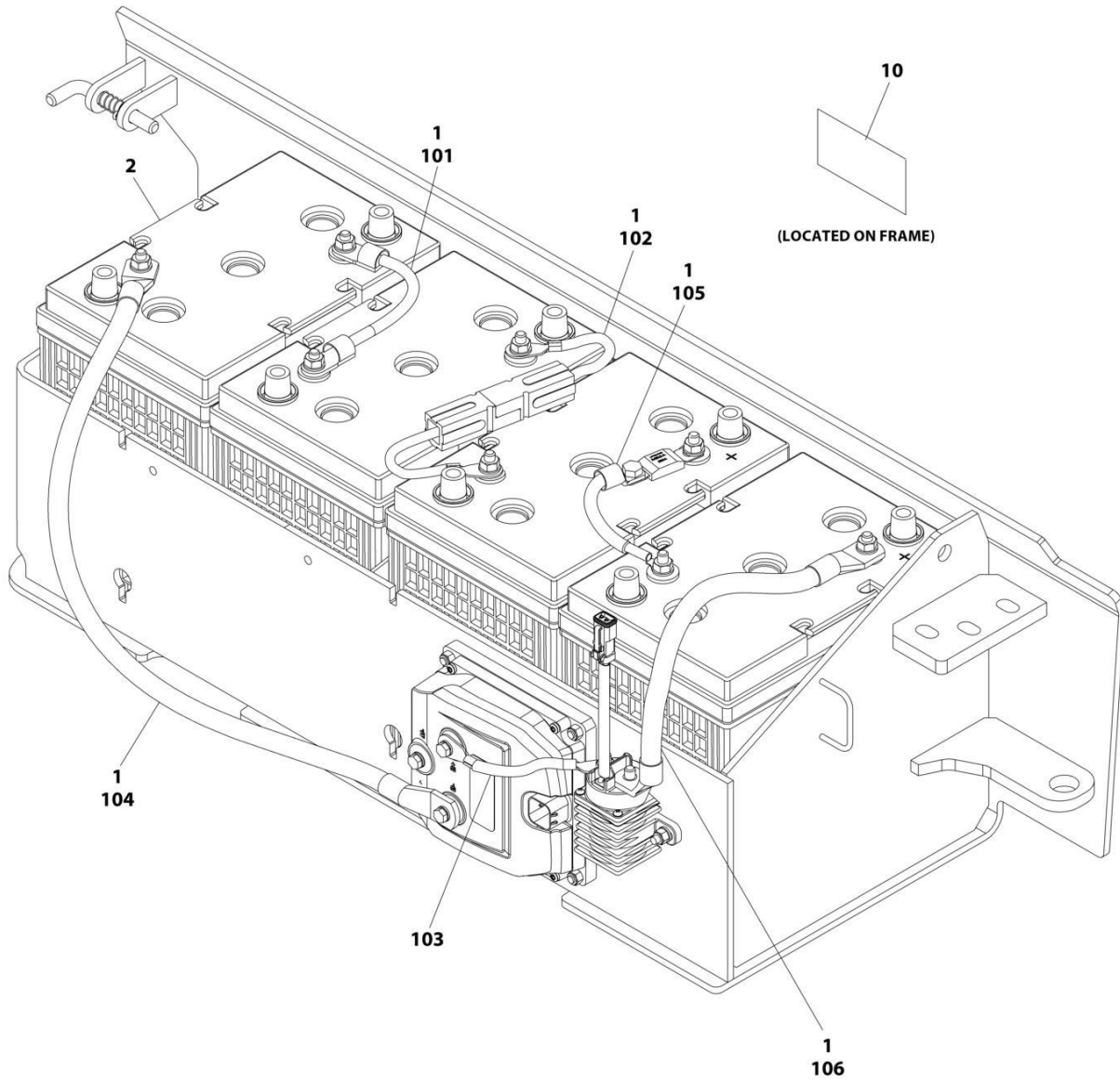

ART_1001216250_E

SECTION 2 - GROUND CONTROLS

**FIGURE 2-11. BATTERIES INSTALLATION - AGM EVCG BATTERIES WITH DISCONNECT
(MACHINES WITH SN STARTING WITH 12, B2 & G2)**

ITEM	PART NUMBER	QTY	DESCRIPTION	REV
	1001216250	Ref	BATTERIES INSTALLATION - AGM EVCG BATTERIES WITH DISCONNECT	E
1	0100051	AR	Grease, Terminal	
2	1001214347	4	Battery	
9	4240017	AR	Tie-Strap (Not Shown)	
10	1702155	1	Decal - Battery Disconnect	
100	1001228123	1	Battery Cable Kit (Not Shown)	A
101	1060998	1	Cable, Positive to Negative	
102	4923328	1	Cable, Positive to Negative	
103	1001201708	1	Cable, Contactor to Pump Control B+	
104	1001201711	1	Cable, Battery Negative to Pump Control B-	
105	1001210401	1	Cable, Battery Fuse	
106	1001229110	1	Cable, Battery Positive to Contactor	

SECTION 2 - GROUND CONTROLS

FIGURE 2-12. BATTERIES INSTALLATION - TROJAN BATTERIES WITH DISCONNECT (MACHINES WITH SN STARTING WITH B2 & G2)

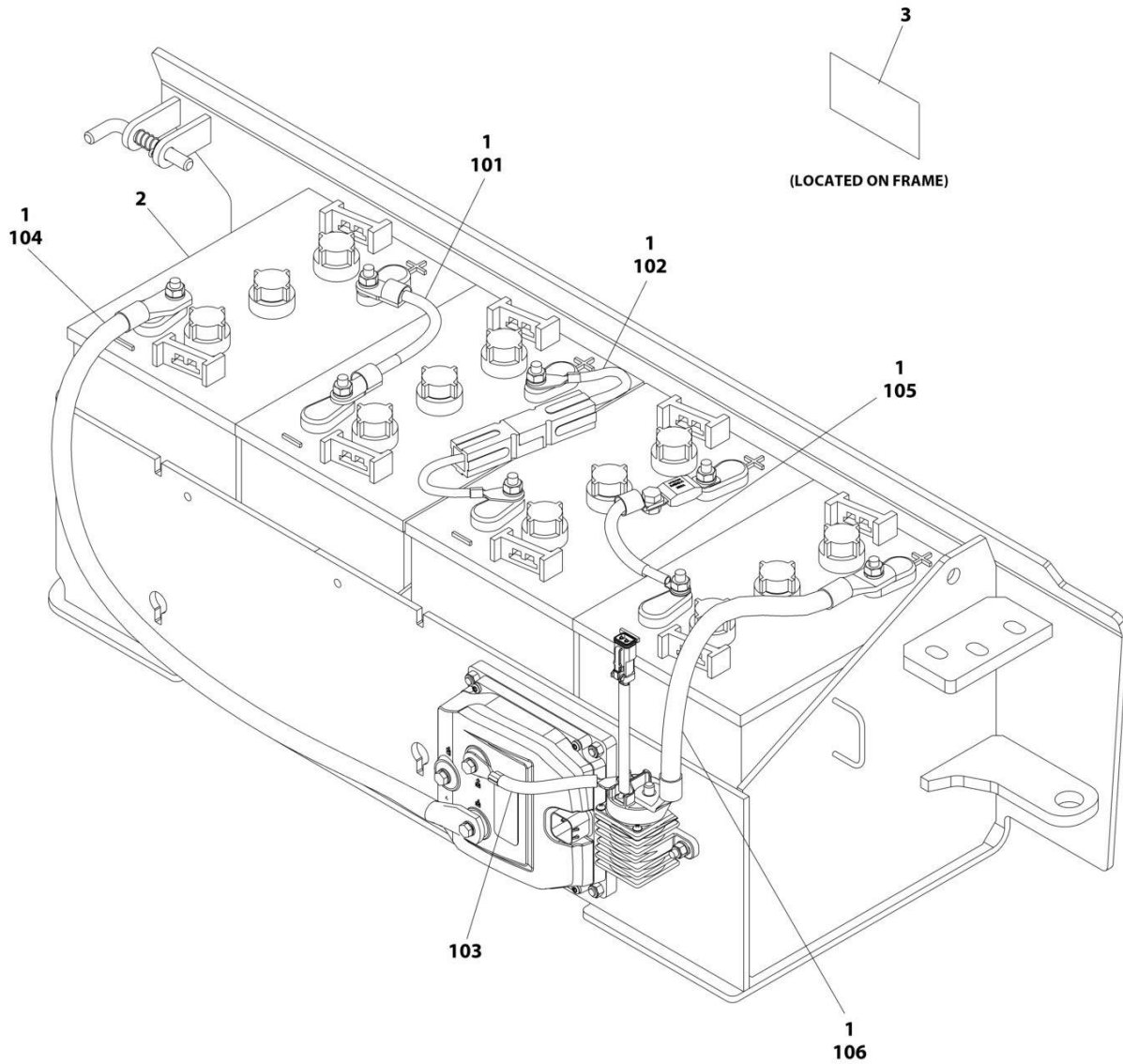

ART_1001247926_B

SECTION 2 - GROUND CONTROLS

FIGURE 2-12. BATTERIES INSTALLATION - TROJAN BATTERIES WITH DISCONNECT (MACHINES WITH SN STARTING WITH B2 & G2)

ITEM	PART NUMBER	QTY	DESCRIPTION	REV
	1001247926	Ref	BATTERIES INSTALLATION - TROJAN BATTERIES WITH DISCONNECT	B
1	0100051	AR	Grease, Terminal	
2	1001258498	4	Battery	
3	1702155	1	Decal - Battery Disconnect	
4	4240017	AR	Tie-Strap (Not Shown)	
100	1001228123	1	Battery Cable Kit (Not Shown)	A
101	1060998	2	Cable, Positive to Negative	
102	4923328	1	Cable, Positive to Negative	
103	1001201708	1	Cable, Contactor to Pump Control B+	
104	1001201711	1	Cable, Battery Negative to Pump Control B-	
105	1001210401	1	Cable, Battery Fuse	
106	1001229110	1	Cable, Battery Positive to Contactor	

SECTION 2 - GROUND CONTROLS

FIGURE 2-13. INVERTER INSTALLATION (OPTIONAL) (MACHINES WITH SN STARTING WITH M2)

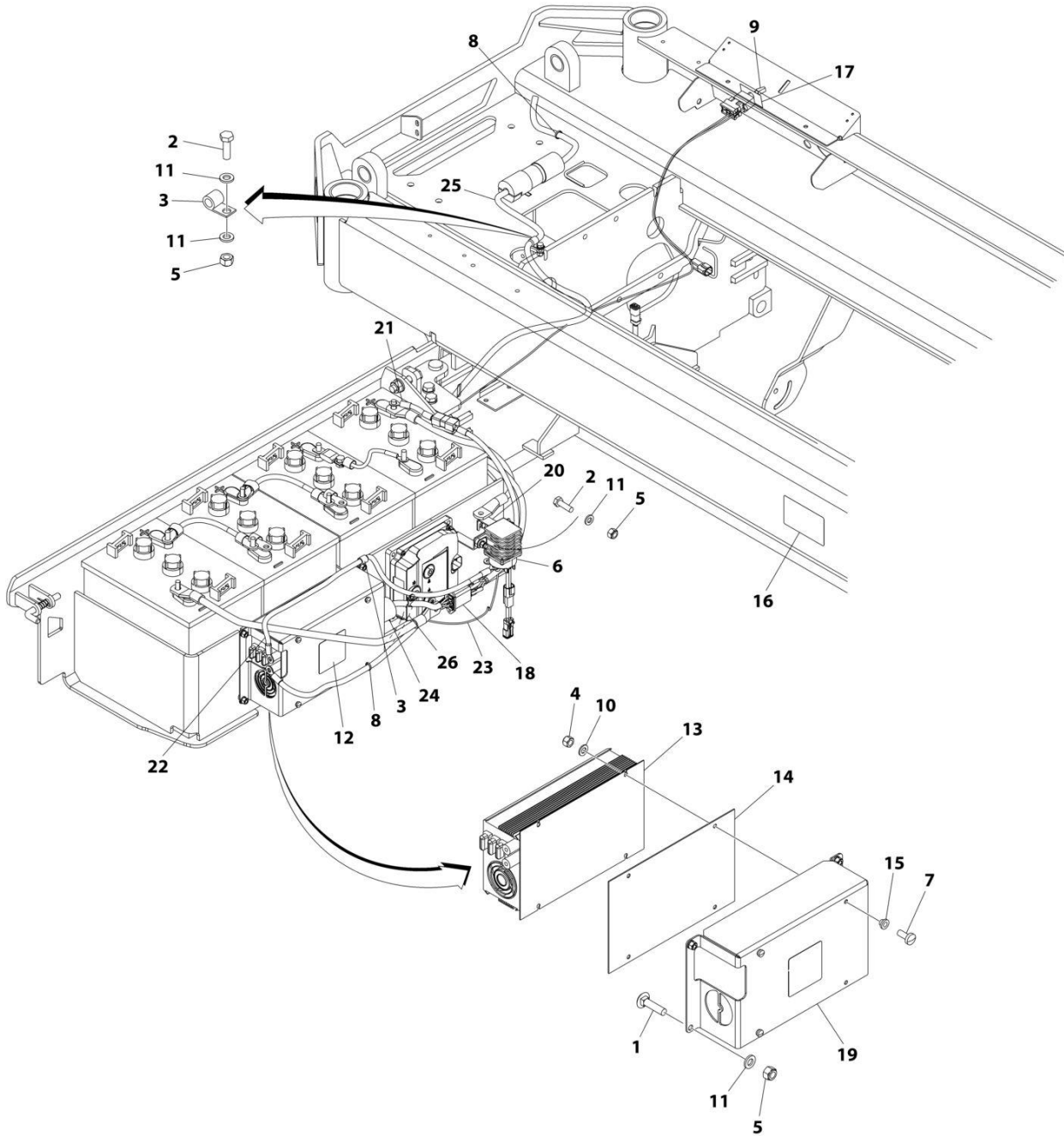

ART_1001209920

SECTION 2 - GROUND CONTROLS

FIGURE 2-13. INVERTER INSTALLATION (OPTIONAL) (MACHINES WITH SN STARTING WITH M2)

ITEM	PART NUMBER	QTY	DESCRIPTION	REV
	1001209920	Ref	INVERTER INSTALLATION (OPTIONAL)	B
1	0630587	4	Bolt M6 x 25	
2	0760610	3	Bolt M6 x 20	
3	1321293	2	Clamp	
4	3290405	3	Nut M4	
5	3290605	7	Nut M6	
6	3740150	1	Relay	
7	1001101540	3	Screw M4 x 14	
8	4240017	AR	Tie-Strap	
9	4360336	1	Switch, Toggle	
10	4811400	3	Washer M4	
11	4811700	8	Washer M6	
12	1001125483	1	Decal - Pressure Wash	
13	1001136757	1	Inverter	
14	1001142173	1	Insulate	
15	1001142174	3	Washer 1/8	
16	1001143009	1	Decal - Inverter	
17	1001143010	1	Decal - On/Off Inverter	
18	1001157547	1	Filter, AC	
19	1001210440	1	Support	
20	1001210605	1	Support	
21	1001210878	1	Cable, Battery + to Inverter Contactor	
22	1001210879	1	Cable, Inverter Contactor to Inverter +	
23	1001210880	1	Inverter Harness	
23	4460897	2	Receptacle, Female - 2 Position	
23	4460464	4	Pin, Male	
23	4460418	1	Plug, Male - 6 Position	
23	4460419	2	Terminal	
24	1001210881	1	Cable, Inverter to AC Filter	
25	1001210882	1	Cable, AC Filter to AC Plug	
26	1001210967	1	Cable, Pump Control B- to Inverter	

SECTION 2 - GROUND CONTROLS

FIGURE 2-14. DOORS INSTALLATION (MACHINES WITH SN STARTING WITH B2, & M2)

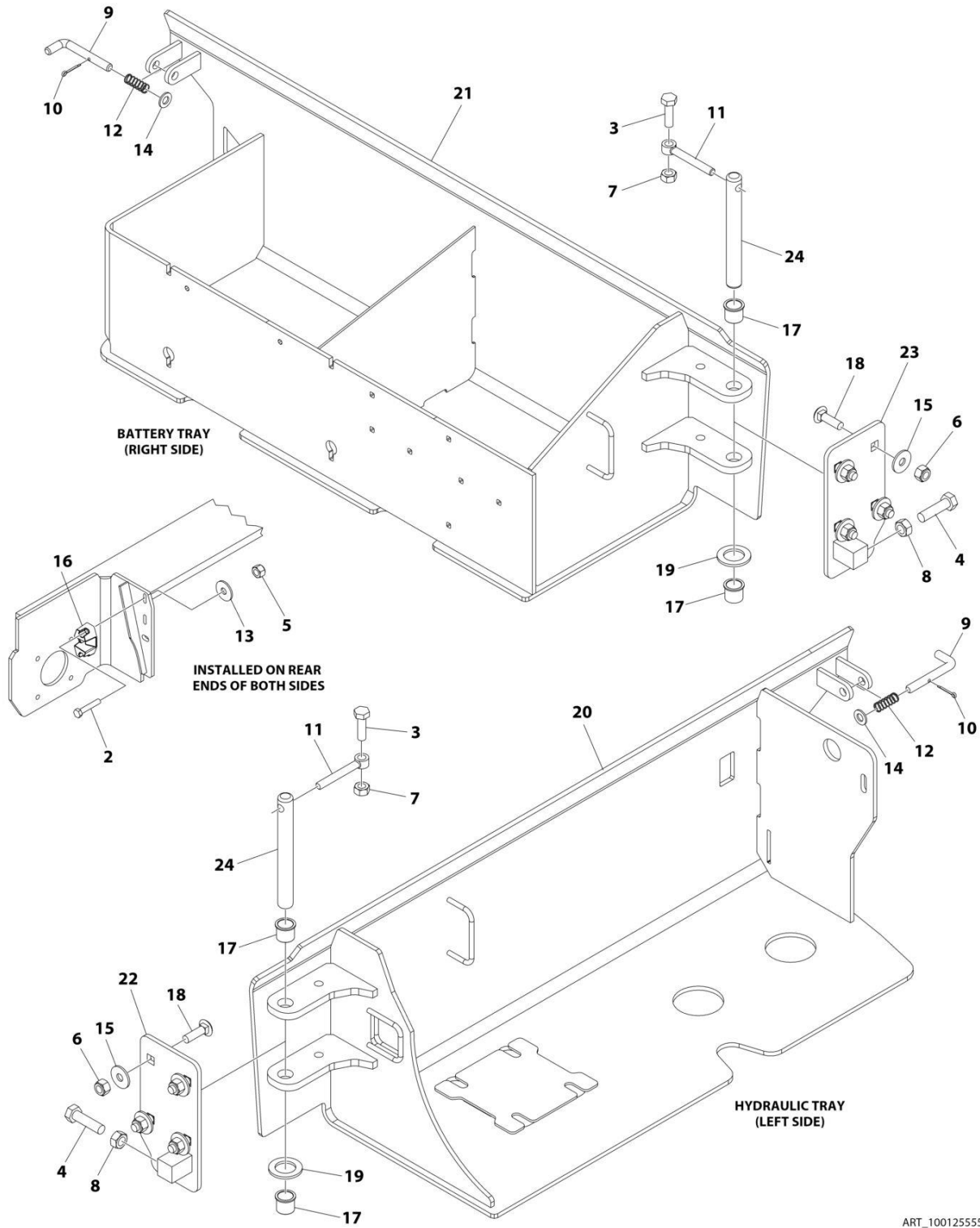

ART_100125555

SECTION 2 - GROUND CONTROLS

FIGURE 2-14. DOORS INSTALLATION (MACHINES WITH SN STARTING WITH B2, & M2)

ITEM	PART NUMBER	QTY	DESCRIPTION	REV
	1001255555	Ref	DOORS INSTALLATION	C
2	0700817	4	Bolt M8 x 45	
3	0701015	2	Bolt M10 x 35	
4	0761217	2	Bolt M12 x 45	
5	3290805	4	Nut M8	
6	3291005	8	Nut M10	
7	3291007	2	Nut M10	
8	3291201	2	Nut M12	
9	3423243	2	Pin	
10	3450303	2	Pin, Cotter 3/32 x 3/4	
11	3841143	2	Keeper, Pin	
12	4160214	2	Spring	
13	4811902	4	Washer M8	
14	4812000	AR	Washer M10	
15	4812002	8	Washer M10	
16	1001214810	2	Support, Door Latch	
17	1001218573	4	Bearing	
18	1001228406	8	Bolt M10 x 35	
19	1001229792	2	Washer	
20	1001251232	1	Tray, Hydraulic	
21	1001251233	1	Tray, Battery	
22	1001251234	1	Hinge (Right)	
23	1001251235	1	Hinge (Left)	
24	1001251242	2	Pin	

SECTION 2 - GROUND CONTROLS

FIGURE 2-15. DOORS INSTALLATION (MACHINES WITH SN STARTING WITH G2)

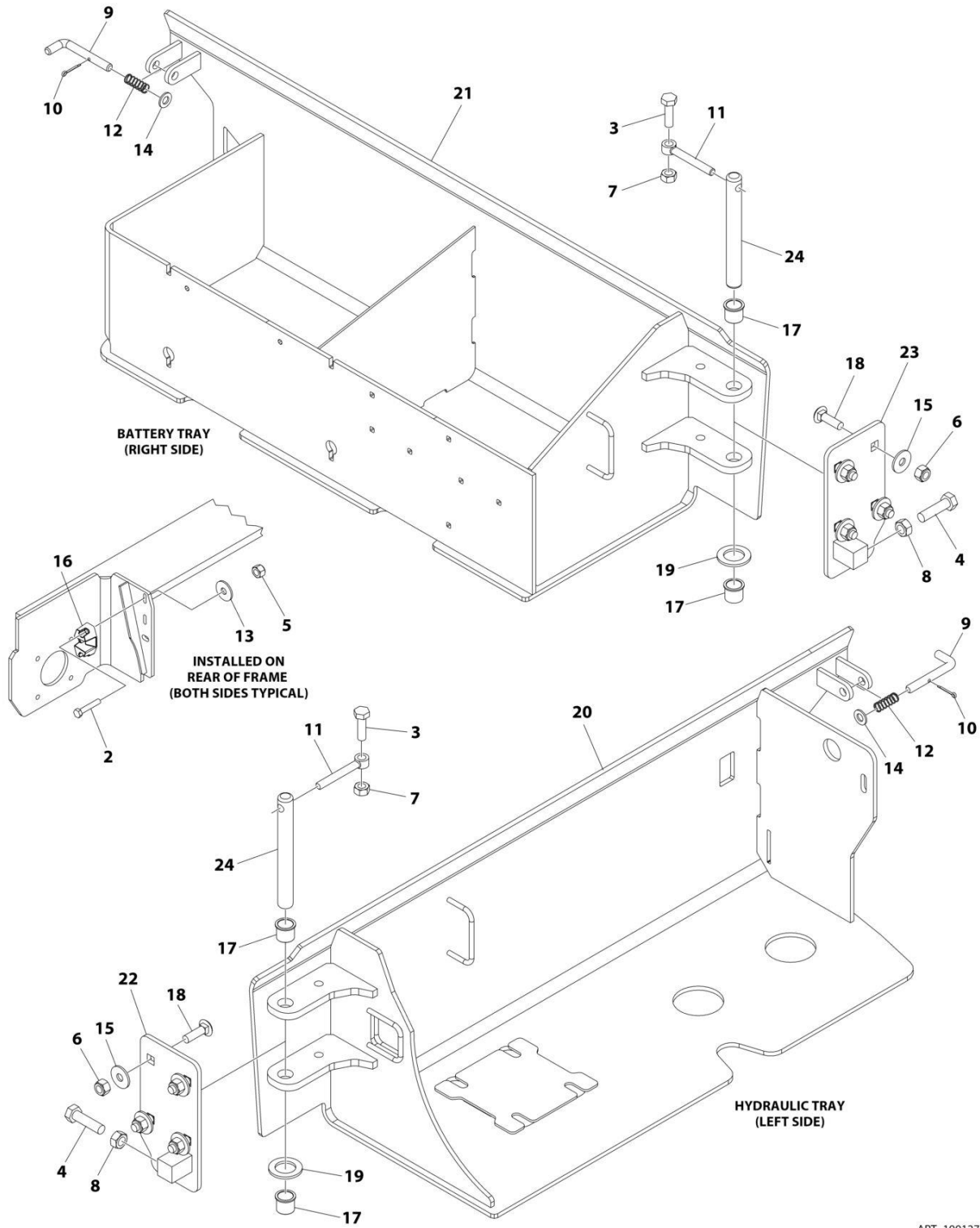

ART_1001276704

SECTION 2 - GROUND CONTROLS

FIGURE 2-15. DOORS INSTALLATION (MACHINES WITH SN STARTING WITH G2)

ITEM	PART NUMBER	QTY	DESCRIPTION	REV
	1001276704	Ref	DOORS INSTALLATION	A
2	0700817	4	Bolt M8 x 45	
3	0701015	2	Bolt M10 x 35	
4	0761217	2	Bolt M12 x 45	
5	3290805	4	Nut M8	
6	3291005	8	Nut M10	
7	3291007	2	Nut M10	
8	3291201	2	Nut M12	
9	3423243	2	Pin	
10	3450303	2	Pin, Cotter	
11	3841143	2	Keeper, Pin	
12	4160214	2	Spring	
13	4811902	4	Washer M8	
14	4812000	AR	Washer M10	
15	4812002	8	Washer M10	
16	1001214810	2	Support, Door Latch	
17	1001276715	4	Bearing	
18	1001228406	8	Bolt M10 x 35	
19	1001276716	2	Washer	
20	1001251232	1	Tray, Hydraulic	
21	1001251233	1	Tray, Battery	
22	1001251234	1	Hinge (Right)	
23	1001251235	1	Hinge (Left)	
24	1001276717	2	Pin	

SECTION 3 - SCISSORS ARMS

SECTION 3 - SCISSORS ARMS

FIGURE 3-1. SCISSORS ARMS INSTALLATION – R1532i (CHINA, KOREAN, CE & UK CA SPECS)

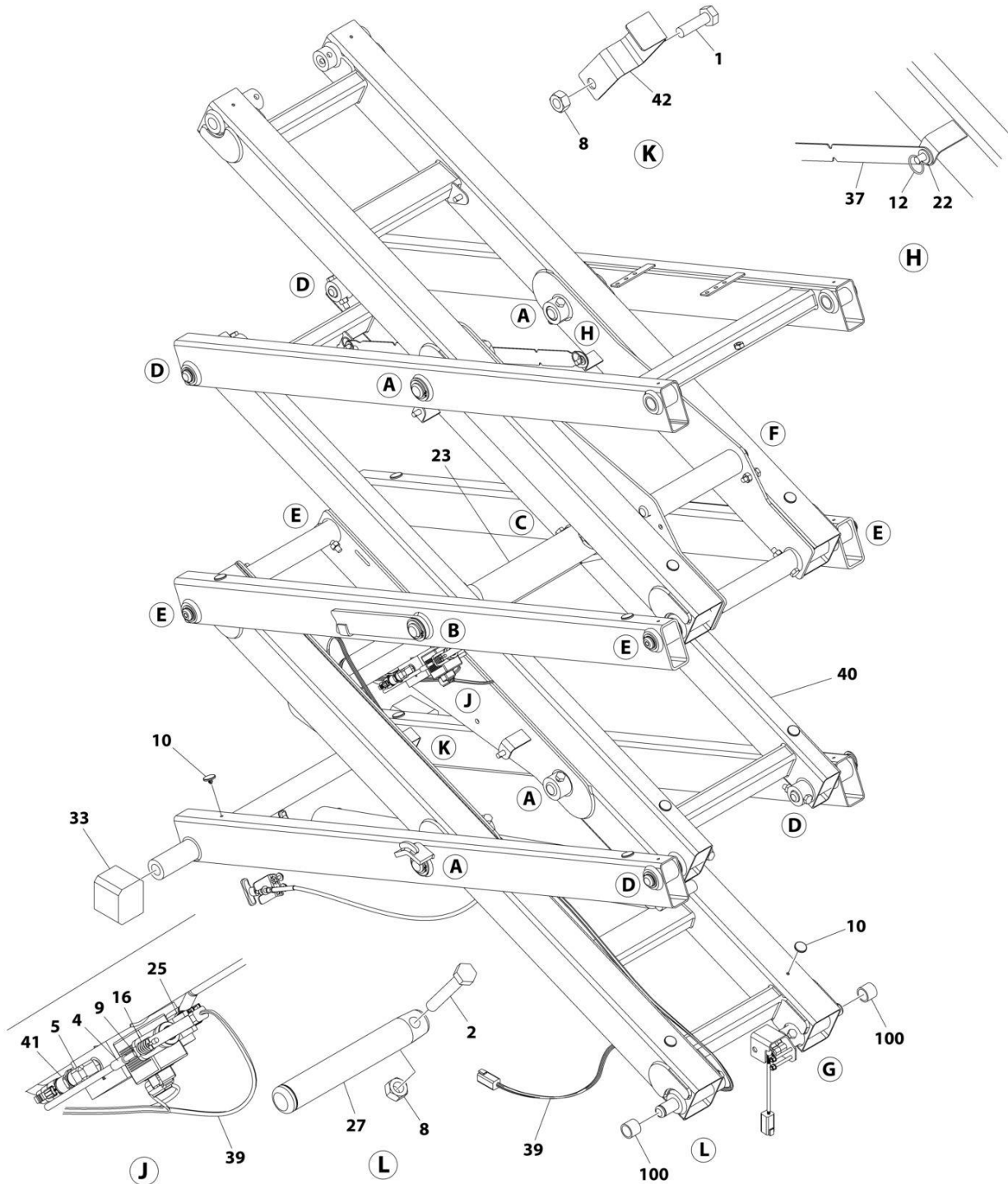

ART_1001235060_E_10F2

SECTION 3 - SCISSORS ARMS

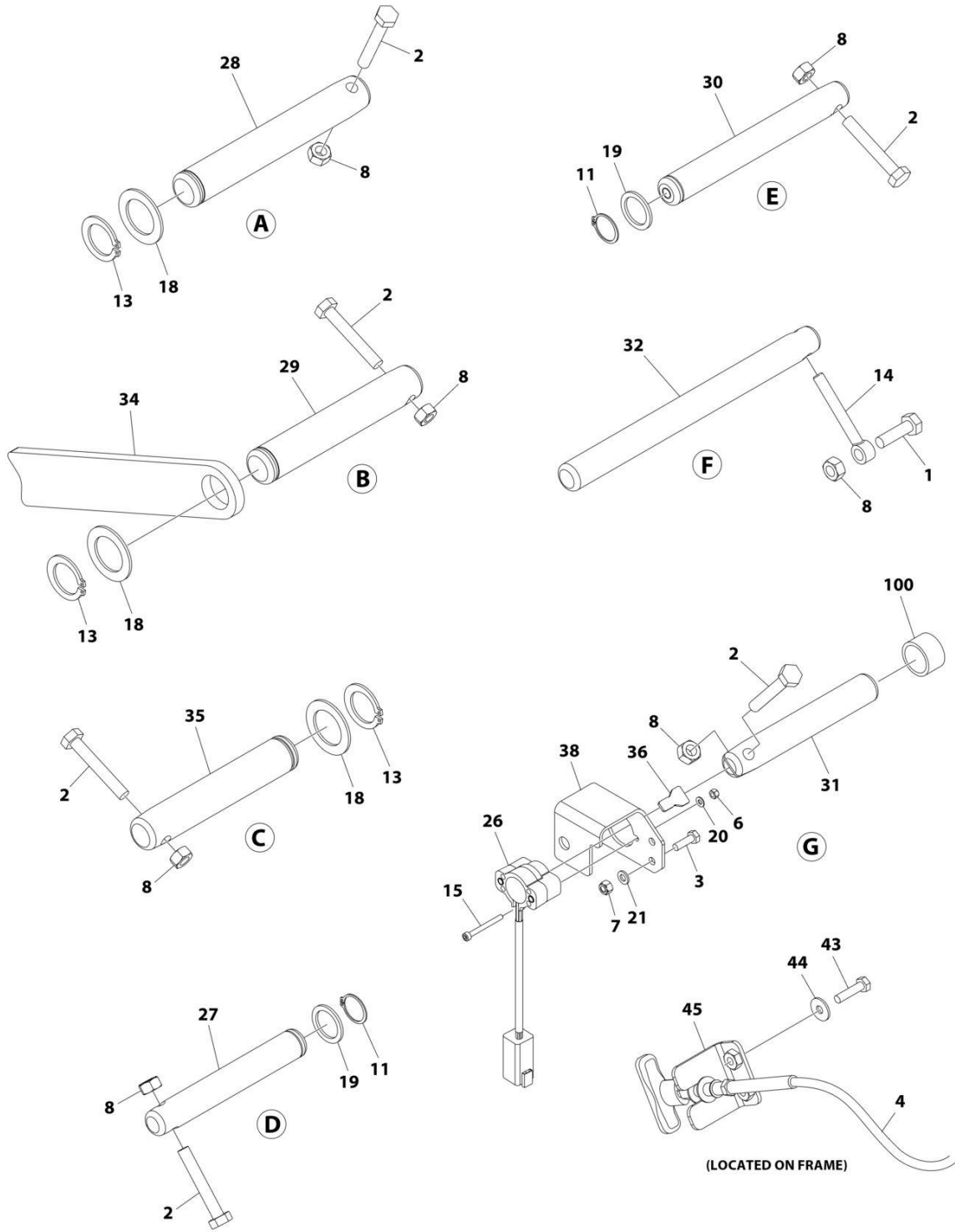

ART_1001235060_E_2OF2

SECTION 3 - SCISSORS ARMS

FIGURE 3-1. SCISSORS ARMS INSTALLATION – R1532I (CHINA, KOREAN, CE & UK CA SPECS)

ITEM	PART NUMBER	QTY	DESCRIPTION	REV
	1001235060	Ref	SCISSORS ARMS INSTALLATION	E
1	0701015	3	Bolt M10 x 35	
2	0701021	16	Bolt M10 x 65	
3	0700620	2	Bolt M6 x 60	
4	1061034	1	Cable, Manual Descent	
4	7020218	1	T-Handle (1/4 Threads)	
4	70001878	1	T-Handle (M5 Threads)	
5	2221116	1	Fitting, 90 ORB/ORB	
6	3290405	2	Nut M4	
7	3290605	2	Nut M6	
8	3291007	19	Nut M10	
9	3321402	1	Nut 1/4	
10	3340962	18	Pad	
11	3760115	8	Ring, Retaining	
12	3760170	2	Ring, Split	
13	3760387	6	Ring, Retaining	
14	3841143	2	Keeper, Pin	
15	4031512	2	Capscrew M4 x 40	
16	4160078	1	Spring	
17	4240017	5	Tie-Strap (Not Shown)	
18	4740438	6	Washer	
19	4740531	8	Washer	
20	4811400	2	Washer M4	
21	4811700	2	Washer M6	
22	4812000	2	Washer M10	
23	1001198935	1	Lift Cylinder Assembly (See Separate Breakdown in CYLINDER SECTION)	
25	1001235104	1	Transducer, Pressure	
26	1001146963	1	Sensor, Angle	
26	4460899	1	Receptacle, Female - 6 Position	
26	4460464	6	Pin, Male	
27	1001203443	5	Pin	
28	1001203444	4	Pin	
29	1001203445	1	Pin	
30	1001203446	4	Pin	
31	1001203447	1	Pin	
32	1001203448	2	Pin	
33	1001204311	2	Block, Slide	
34	1001204312	1	Plate, Prop	
35	1001204994	1	Pin	
36	1001234204	1	Key, Angle Sensor	
37	1001206487	1	Support	
38	1001231268	1	Mount, Sensor	
39	1001222687	1	Lift Down Harness (See Separate Breakdown in ELECTRICAL SECTION)	
40	1001235059	1	Scissors Arms Kit (See Separate Breakdown in this Section)	
41	1001225164	1	Transducer, Pressure	
42	1001226791	1	Bracket	
43	0760612	2	Bolt M6 x 25	
44	4811702	2	Washer M6	

SECTION 3 - SCISSORS ARMS

ITEM	PART NUMBER	QTY	DESCRIPTION	REV
45	1001253153	1	Mount	
100	1001134289	2	Bearing (Part of Frame)	

SECTION 3 - SCISSORS ARMS

FIGURE 3-2. SCISSORS ARMS INSTALLATION – R1532i (ANSI, ANSI EXPORT AND CSA SPECS)
(Prior to SN B200076287)

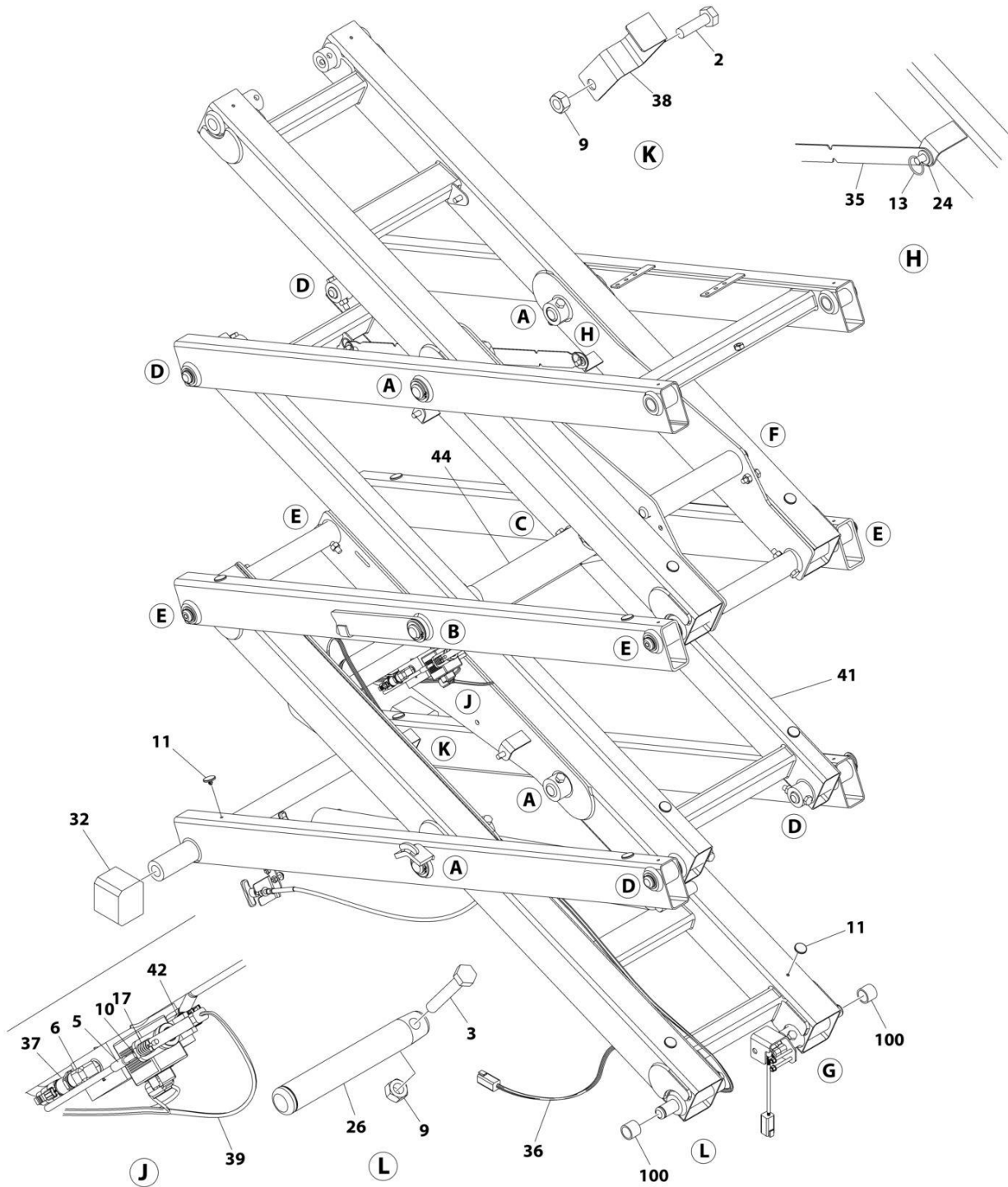

ART_1001263536_10F2

SECTION 3 - SCISSORS ARMS

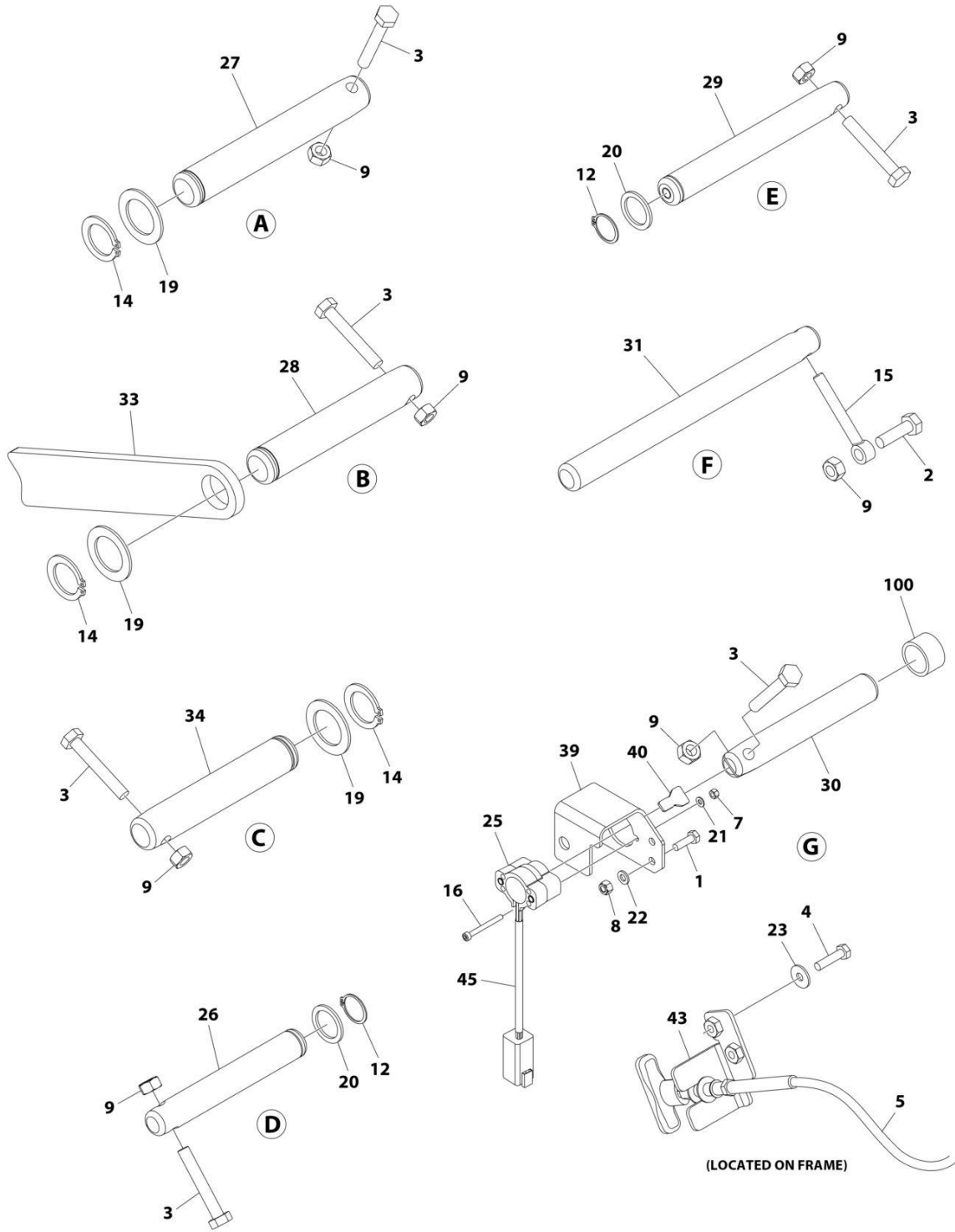

ART_1001263536_2OF2

SECTION 3 - SCISSORS ARMS

**FIGURE 3-2. SCISSORS ARMS INSTALLATION – R1532I (ANSI, ANSI EXPORT AND CSA SPECS)
(Prior to SN B200076287)**

ITEM	PART NUMBER	QTY	DESCRIPTION	REV
	1001263536	Ref	SCISSORS ARMS INSTALLATION	C
1	0700620	2	Bolt M6 x 60	
2	0701015	3	Bolt M10 x 35	
3	0701021	16	Bolt M10 x 65	
4	0760612	2	Bolt M6 x 25	
5	1061034	1	Cable, Manual Descent	
5	7020218	1	T-Handle (1/4 Threads)	
5	70001878	1	T-Handle (M5 Threads)	
6	2221116	1	Fitting, 90 ORB/ORB	
7	3290405	2	Nut M4	
8	3290605	2	Nut M6	
9	3291007	19	Nut M10	
10	3321402	1	Nut 1/4	
11	3340962	18	Pad	
12	3760115	8	Ring, Retaining	
13	3760170	2	Ring, Split	
14	3760387	6	Ring, Retaining	
15	3841143	2	Keeper, Pin	
16	4031512	2	Capscrew M4 x 40	
17	4160078	1	Spring	
18	4240017	5	Tie-Strap (Not Shown)	
19	4740438	6	Washer	
20	4740531	8	Washer	
21	4811400	2	Washer M4	
22	4811700	2	Washer M6	
23	4811702	2	Washer M6	
24	4812000	2	Washer M10	
25	1001146963	1	Sensor, Angle	
25	4460899	1	Receptacle, Female - 6 Position	
25	4460464	6	Pin, Male	
26	1001203443	5	Pin	
27	1001203444	4	Pin	
28	1001203445	1	Pin	
29	1001203446	4	Pin	
30	1001203447	1	Pin	
31	1001203448	2	Pin	
32	1001204311	2	Block, Slide	
33	1001204312	1	Plate, Prop	
34	1001204994	1	Pin	
35	1001206487	1	Support	
36	1001222687	1	Lift Down Harness (See Separate Breakdown in ELECTRICAL Section)	
37	1001225164	1	Transducer, Pressure	
38	1001226791	1	Bracket	
39	1001231268	1	Mount, Sensor	
40	1001234204	1	Key, Angle Sensor	
41	1001235059	1	Scissors Arms Kit (See Separate Breakdown in this Section)	
42	1001235104	1	Transducer, Pressure	
43	1001253153	1	Mount	

SECTION 3 - SCISSORS ARMS

ITEM	PART NUMBER	QTY	DESCRIPTION	REV
44	1001256787	1	Lift Cylinder Assembly (See Separate Breakdown in CYLINDER Section)	
45	1001262299	1	Conduit	
100	1001134289	2	Bearing (Part of Frame)	

SECTION 3 - SCISSORS ARMS

FIGURE 3-3. SCISSORS ARMS INSTALLATION – R1532i (ANSI, ANSI EXPORT AND CSA SPECS) (SN B200076287 to Present)

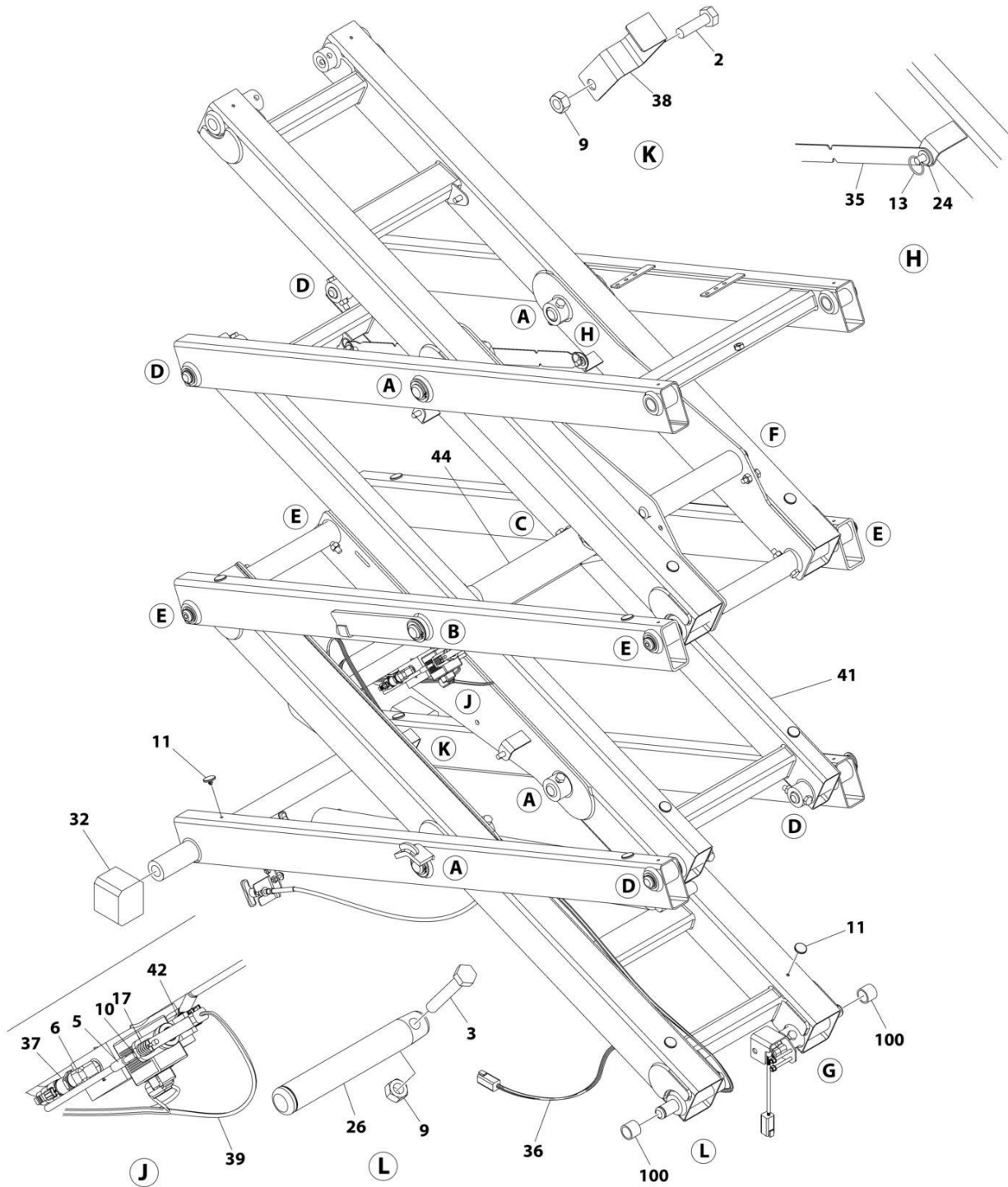

ART_1001263536_D_10F2

SECTION 3 - SCISSORS ARMS

FIGURE 3-4. SCISSORS ARMS INSTALLATION – R1532i (ANSI, ANSI EXPORT AND CSA SPECS) (SN B200076287 to Present)

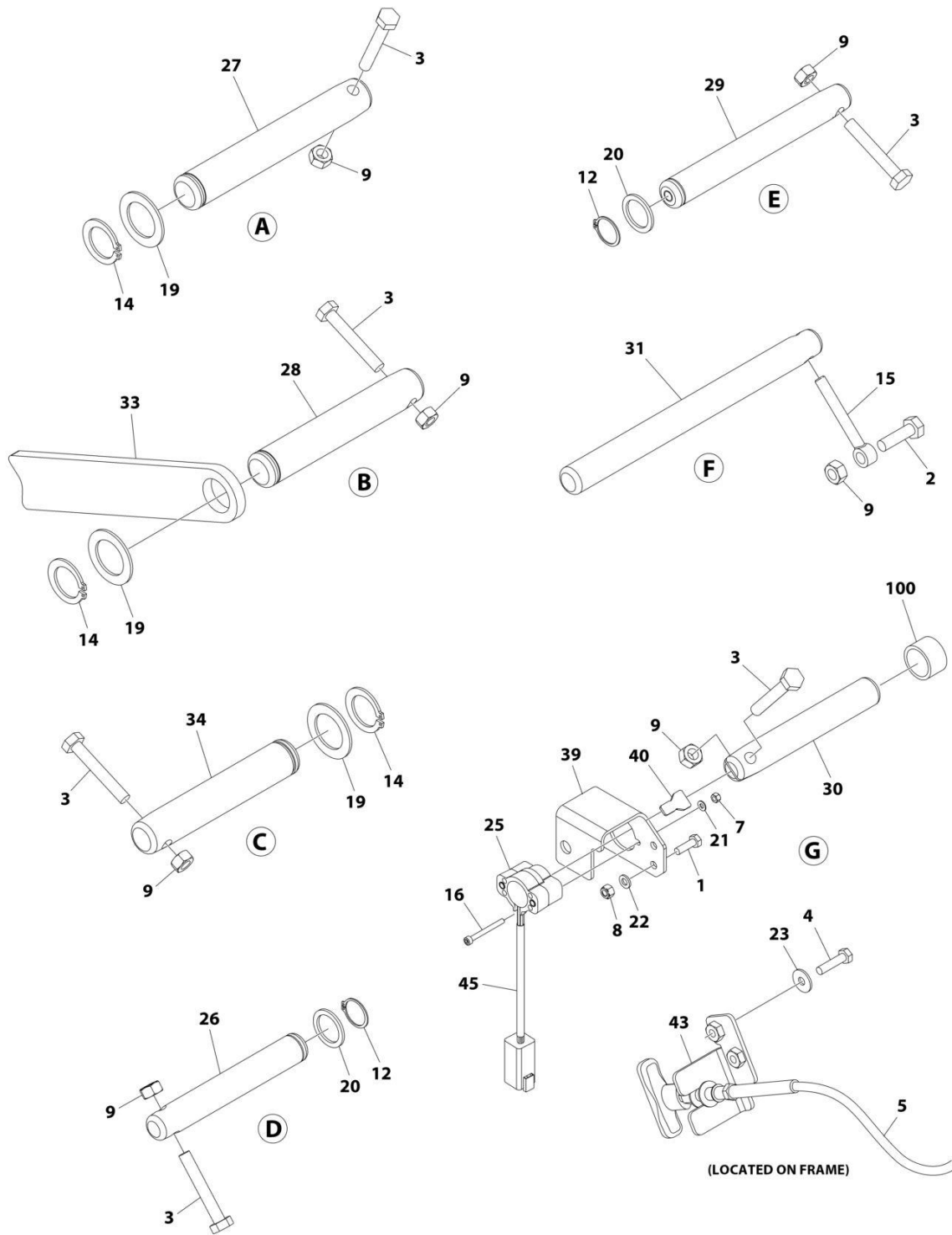

ART_1001263536_D_20F2

SECTION 3 - SCISSORS ARMS

FIGURE 3-4. SCISSORS ARMS INSTALLATION – R1532I (ANSI, ANSI EXPORT AND CSA SPECS) (SN B200076287 to Present)

ITEM	PART NUMBER	QTY	DESCRIPTION	REV
	1001263536	Ref	SCISSORS ARMS INSTALLATION	D
1	0700620	2	Bolt M6 x 60	
2	0701015	3	Bolt M10 x 35	
3	0701021	16	Bolt M10 x 65	
4	0760612	2	Bolt M6 x 25	
5	1061034	1	Cable, Manual Descent	
5	7020218	1	T-Handle (1/4 Threads)	
5	70001878	1	T-Handle (M5 Threads)	
6	2221116	1	Fitting, 90 ORB/ORB	
7	3290405	2	Nut M4	
8	3290605	2	Nut M6	
9	3291007	19	Nut M10	
10	3321402	1	Nut 1/4	
11	3340962	18	Pad	
12	3760115	8	Ring, Retaining	
13	3760170	2	Ring, Split	
14	3760387	6	Ring, Retaining	
15	3841143	2	Keeper, Pin	
16	4031512	2	Capscrew M4 x 40	
17	4160078	1	Spring	
18	4240017	5	Tie-Strap (Not Shown)	
19	4740438	6	Washer	
20	4740531	8	Washer	
21	4811400	2	Washer M4	
22	4811700	2	Washer M6	
23	4811702	2	Washer M6	
24	4812000	2	Washer M10	
25	1001146963	1	Sensor, Angle	
25	4460899	1	Receptacle, Female - 6 Position	
25	4460464	6	Pin, Male	
26	1001203443	5	Pin	
27	1001203444	4	Pin	
28	1001203445	1	Pin	
29	1001203446	4	Pin	
30	1001203447	1	Pin	
31	1001203448	2	Pin	
32	1001204311	2	Block, Slide	
33	1001204312	1	Plate, Prop	
34	1001204994	1	Pin	
35	1001206487	1	Support	
36	1001222687	1	Lift Down Harness (See Separate Breakdown in ELECTRICAL Section)	
37	1001225164	1	Transducer, Pressure	
38	1001226791	1	Bracket	
39	1001231268	1	Mount, Sensor	
40	1001234204	1	Key, Angle Sensor	
41	1001235059	1	Scissors Arms Kit (See Separate Breakdown in this Section)	
42	1001285320	1	Transducer, Pressure	
43	1001253153	1	Mount	

SECTION 3 - SCISSORS ARMS

ITEM	PART NUMBER	QTY	DESCRIPTION	REV
44	1001256787	1	Lift Cylinder Assembly (See Separate Breakdown in CYLINDER Section)	
45	1001262299	1	Conduit	
46	1001285829	1	Harness, Jumper (Not Shown) (See Separate Breakdown in ELECTRICAL Section)	
100	1001134289	2	Bearing (Part of Frame)	

SECTION 3 - SCISSORS ARMS

FIGURE 3-5. SCISSORS ARMS INSTALLATION – R1932/R1932i (MACHINES WITH SN STARTING WITH M2) (Prior to SN M200060339)

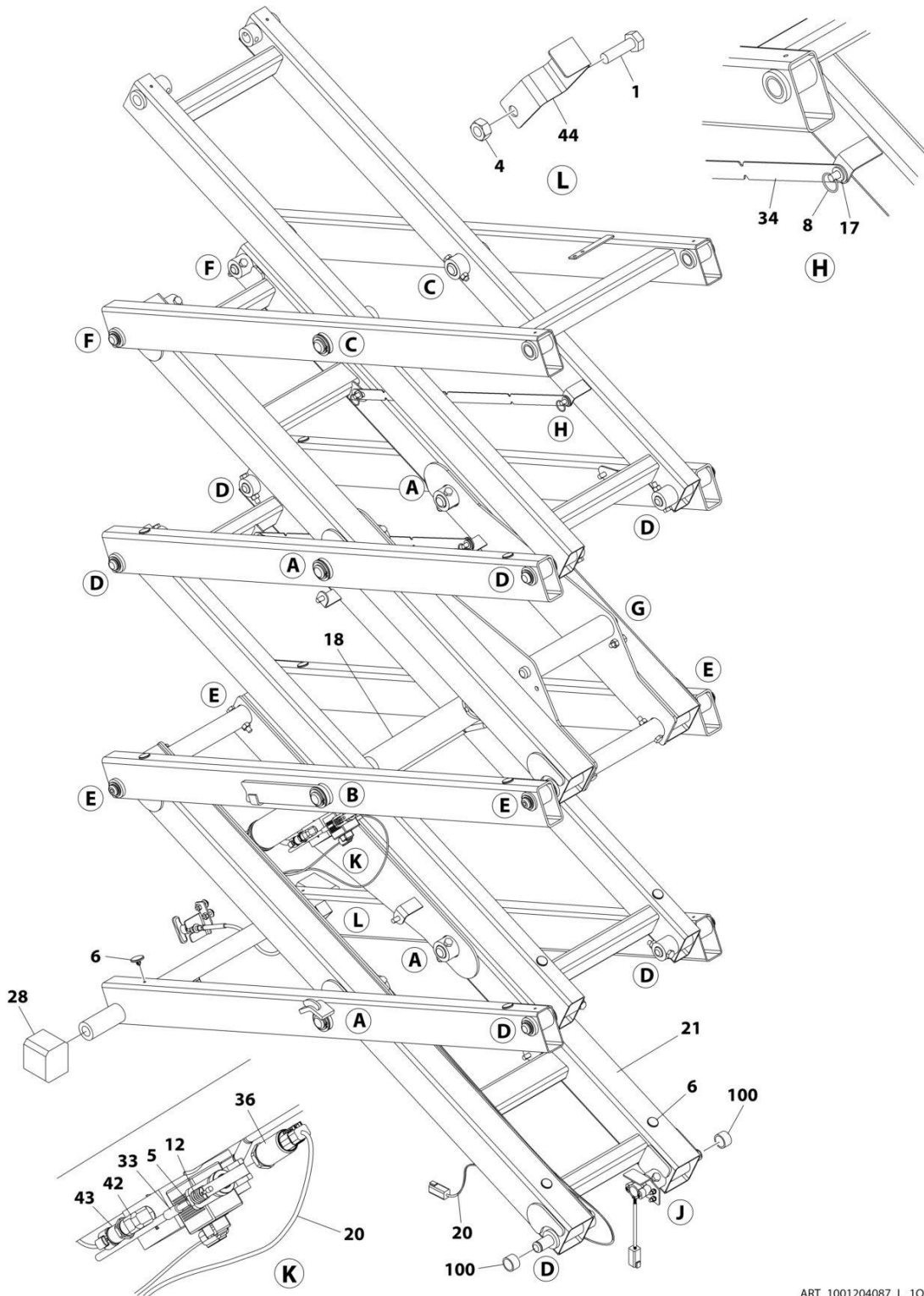

ART_1001204087_L_10F2

SECTION 3 - SCISSORS ARMS

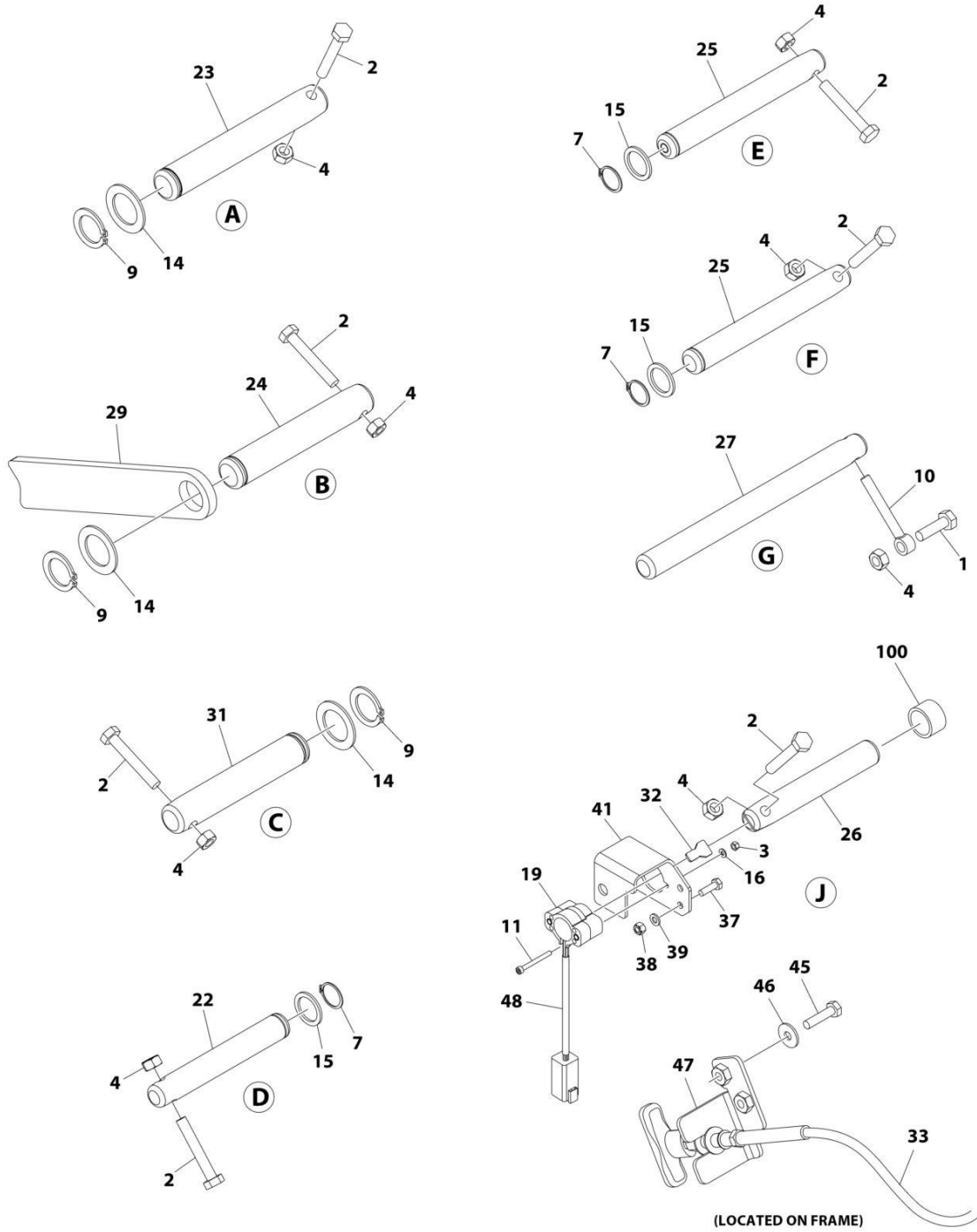

ART_1001204087_L_20F2

SECTION 3 - SCISSORS ARMS

FIGURE 3-5. SCISSORS ARMS INSTALLATION – R1932/R1932I (MACHINES WITH SN STARTING WITH M2) (Prior to SN M200060339)

ITEM	PART NUMBER	QTY	DESCRIPTION	REV
	1001204087	Ref	SCISSORS ARMS INSTALLATION	L
1	0701015	AR	Bolt M10 x 35	
2	0701021	22	Bolt M10 x 65	
3	3290405	2	Nut M4	
4	3291007	AR	Nut M10	
5	3321402	1	Nut 1/4	
6	3340962	24	Pad	
7	3760115	12	Ring, Retaining	
8	3760170	4	Ring, Split	
9	3760387	8	Ring, Retaining	
10	3841143	2	Keeper, Pin	
11	4031512	2	Capscrew M4 x 40	
12	4160078	1	Spring	
13	4240017	5	Tie-Strap (Not Shown)	
14	4740438	8	Washer	
15	4740531	12	Washer	
16	4811400	2	Washer M4	
17	4812000	4	Washer M10	
18	1001198935	1	Lift Cylinder Assembly (See Separate Breakdown in CYLINDER Section)	
19	1001146963	1	Sensor, Angle	
19	4460899	1	Receptacle, Female - 6 Position	
19	4460464	6	Pin, Male	
20	1001222687	1	Lift Down Harness (See Separate Breakdown in ELECTRICAL Section)	
21	1001201355	1	Scissors Arms Kit (See Separate Breakdown in this Section)	
22	1001203443	7	Pin	
23	1001203444	4	Pin	
24	1001203445	1	Pin	
25	1001203446	6	Pin	
26	1001203447	1	Pin	
27	1001203448	2	Pin	
28	1001204311	2	Block, Slide	
29	1001204312	1	Plate, Prop	
31	1001204994	3	Pin	
32	1001234204	1	Key, Angle Sensor	
33	1061034	1	Cable, Manual Descent	
33	7020218	1	T-Handle (1/4 Threads)	
33	70001878	1	T-Handle (M5 Threads)	
34	1001206487	2	Support	
36	1001235104	1	Transducer, Pressure	
37	0700620	2	Bolt M6 x 60	
38	3290605	2	Nut M6	
39	4811700	2	Washer M6	
41	1001231268	1	Mount, Sensor	
42	2221116	1	Fitting, 90 ORB/ORB	
43	1001225164	1	Transducer, Pressure	
44	1001226791	1	Bracket	
45	0760612	2	Bolt M6 x 25	

SECTION 3 - SCISSORS ARMS

ITEM	PART NUMBER	QTY	DESCRIPTION	REV
46	4811702	2	Washer M6	
47	1001253153	1	Mount	
48	280013	6.5 in/16.5cm	Conduit	
100	1001134289	2	Bearing (Part of Frame)	

SECTION 3 - SCISSORS ARMS

FIGURE 3-6. SCISSORS ARMS INSTALLATION – R1932/R1932I (MACHINES WITH SN STARTING WITH B2)

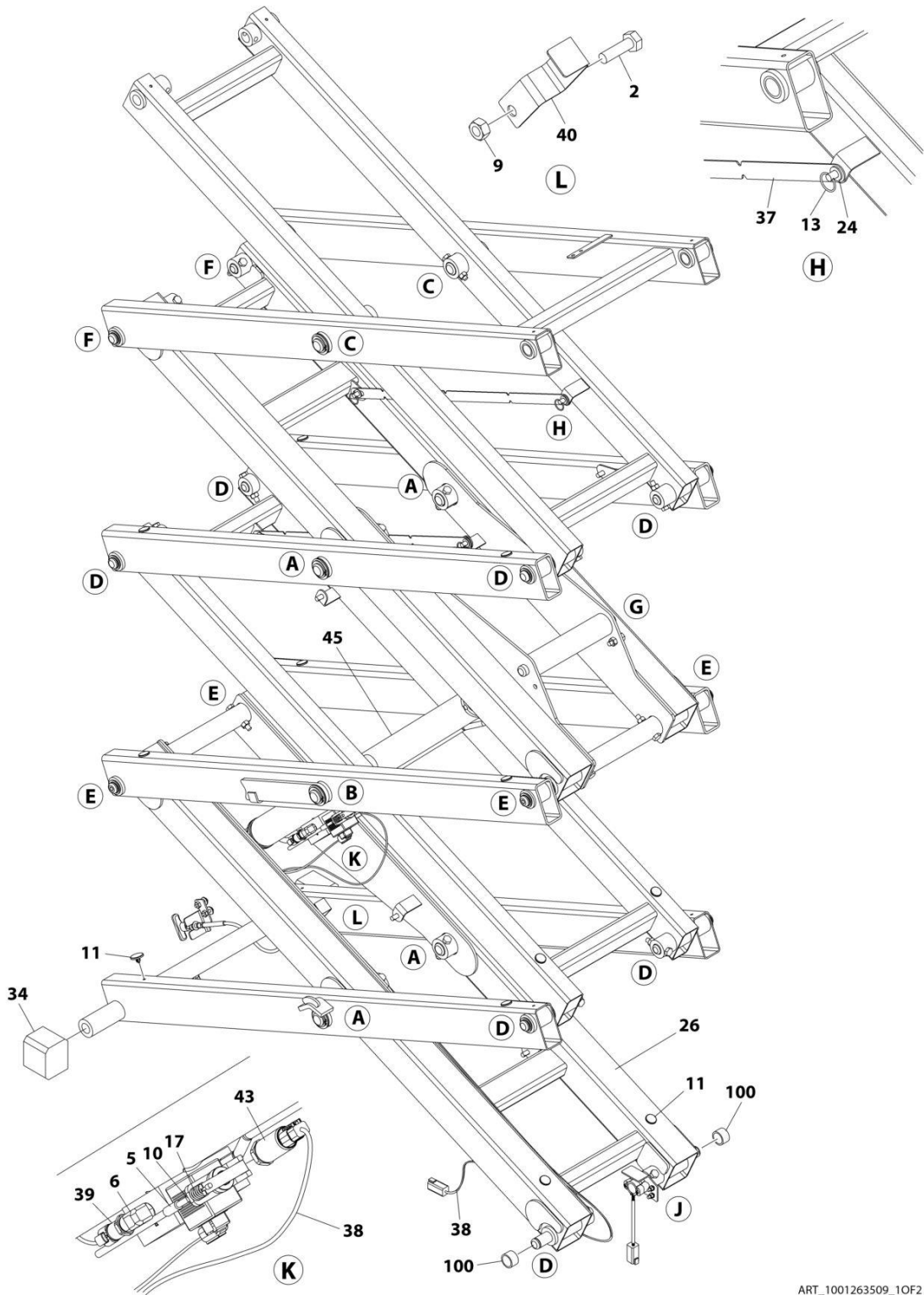

ART_1001263509_10F2

SECTION 3 - SCISSORS ARMS

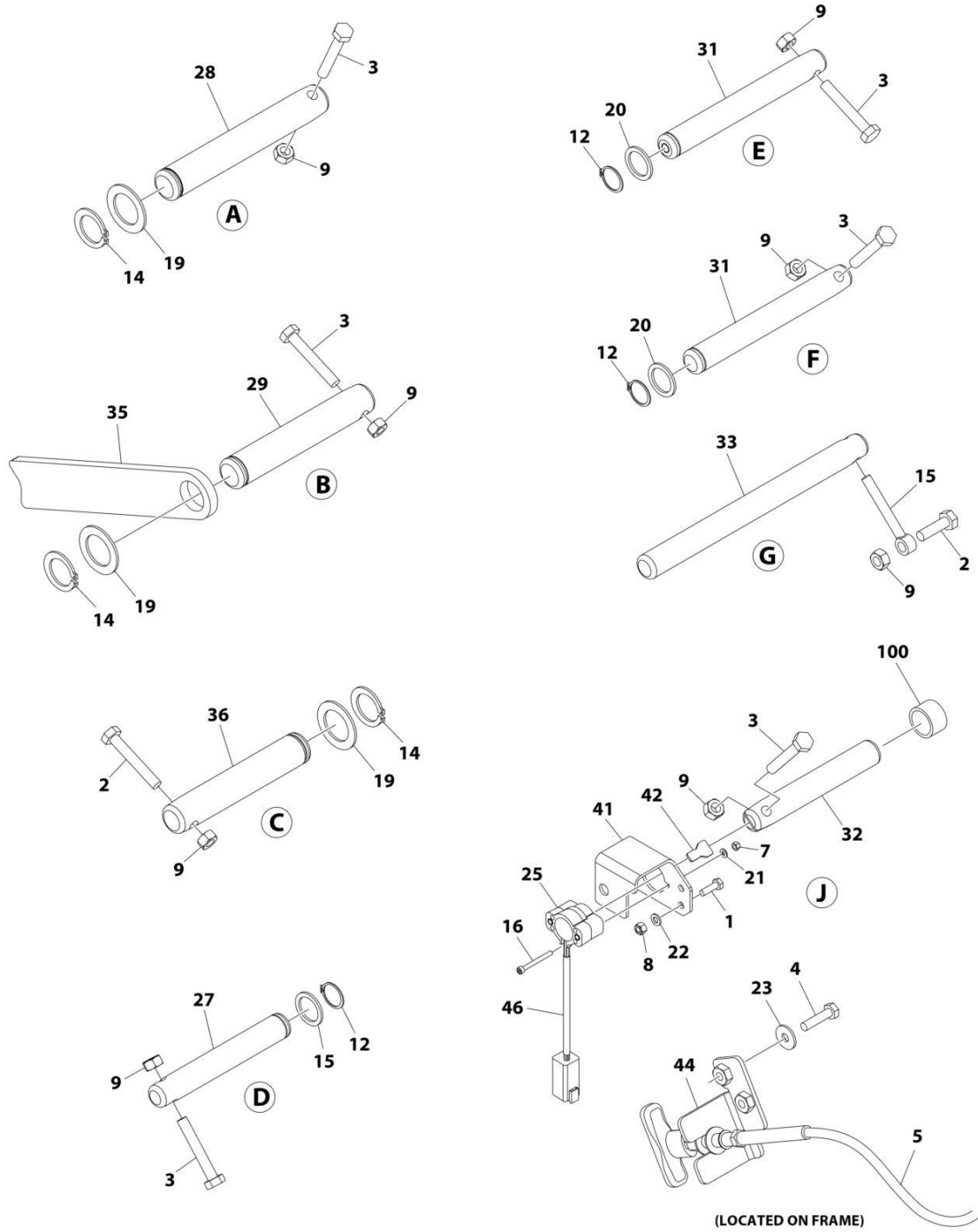

ART_1001263509_20F2

SECTION 3 - SCISSORS ARMS

FIGURE 3-6. SCISSORS ARMS INSTALLATION – R1932/R1932I (MACHINES WITH SN STARTING WITH B2)

ITEM	PART NUMBER	QTY	DESCRIPTION	REV
	1001263509	Ref	SCISSORS ARMS INSTALLATION	C
1	0700620	2	Bolt M6 x 60	
2	0701015	3	Bolt M10 x 35	
3	0701021	22	Bolt M10 x 65	
4	0760612	2	Bolt M6 x 25	
5	1061034	1	Cable, Manual Descent	
5	7020218	1	T-Handle (1/4 Threads)	
5	70001878	1	T-Handle (M5 Threads)	
6	2221116	1	Fitting, 90 ORB/ORB	
7	3290405	2	Nut M4	
8	3290605	2	Nut M6	
9	3291007	25	Nut M10	
10	3321402	1	Nut 1/4	
11	3340962	24	Pad	
12	3760115	12	Ring, Retaining	
13	3760170	4	Ring, Split	
14	3760387	8	Ring, Retaining	
15	3841143	2	Keeper, Pin	
16	4031512	2	Capscrew M4 x 40	
17	4160078	1	Spring	
18	4240017	5	Tie-Strap (Not Shown)	
19	4740438	8	Washer	
20	4740531	12	Washer	
21	4811400	2	Washer M4	
22	4811700	2	Washer M6	
23	4811702	2	Washer M6	
24	4812000	4	Washer M10	
25	1001146963	1	Sensor, Angle	
25	4460899	1	Receptacle, Female - 6 Position	
25	4460464	6	Pin, Male	
26	1001201355	1	Scissors Arms Kit (See Separate Breakdown in this Section)	
27	1001203443	7	Pin	
28	1001203444	4	Pin	
29	1001203445	1	Pin	
31	1001203446	6	Pin	
32	1001203447	1	Pin	
33	1001203448	2	Pin	
34	1001204311	2	Block, Slide	
35	1001204312	1	Plate, Prop	
36	1001204994	3	Pin	
37	1001206487	2	Support	
38	1001222687	1	Lift Down Harness (See Separate Breakdown in ELECTRICAL Section)	
39	1001225164	1	Transducer, Pressure	
40	1001226791	1	Bracket	
41	1001231268	1	Mount, Sensor	
42	1001234204	1	Key, Angle Sensor	
43	1001235104	1	Transducer, Pressure	
44	1001253153	1	Mount	

SECTION 3 - SCISSORS ARMS

ITEM	PART NUMBER	QTY	DESCRIPTION	REV
45	1001256787	1	Lift Cylinder Assembly (See Separate Breakdown in CYLINDER Section)	
46	1001262299	1	Conduit	
100	1001134289	2	Bearing (Part of Frame)	

SECTION 3 - SCISSORS ARMS

FIGURE 3-7. SCISSORS ARMS INSTALLATION - R1932/R1932I (MACHINES WITH SN STARTING WITH G2)

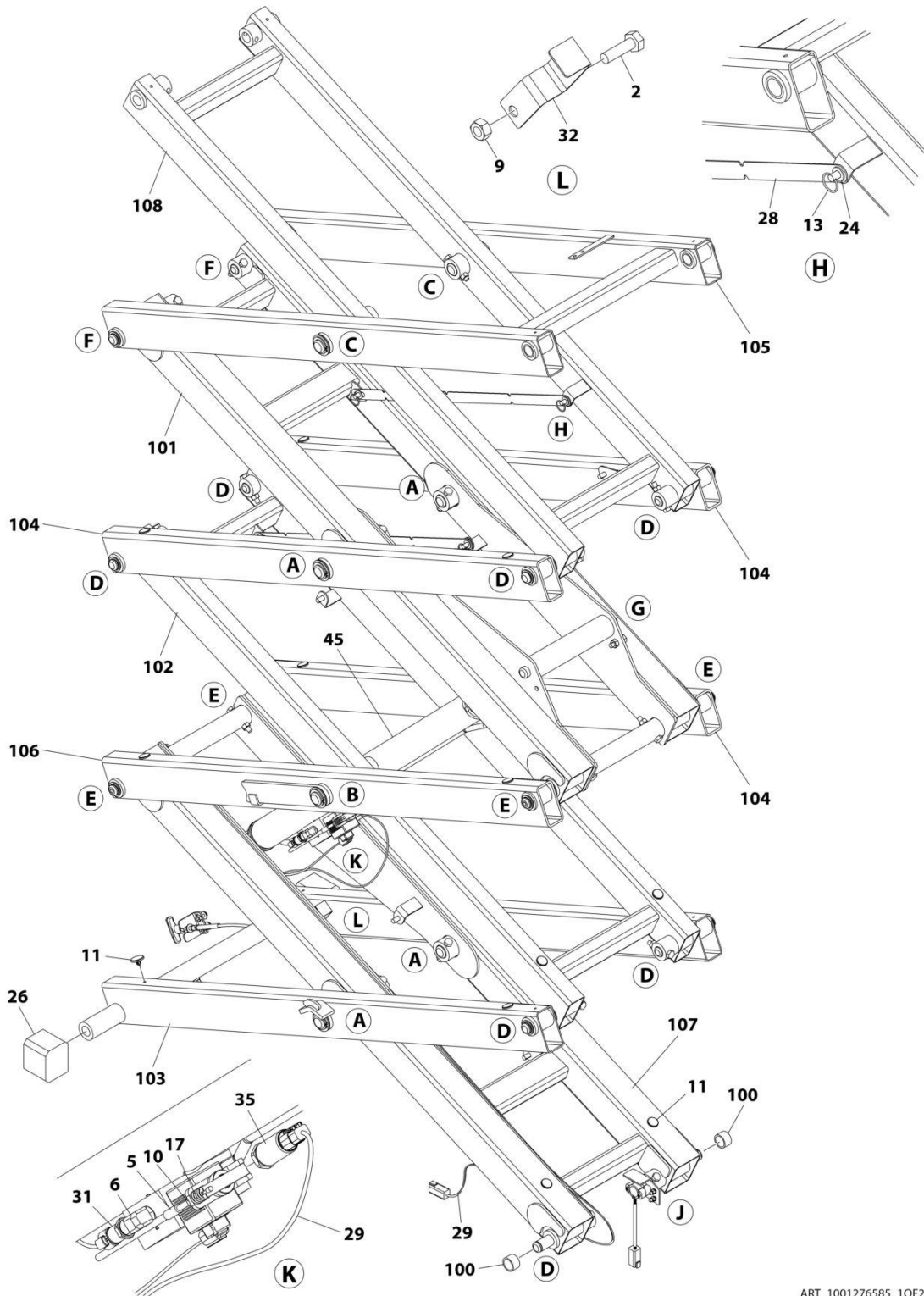

ART_1001276585_10F2

SECTION 3 - SCISSORS ARMS

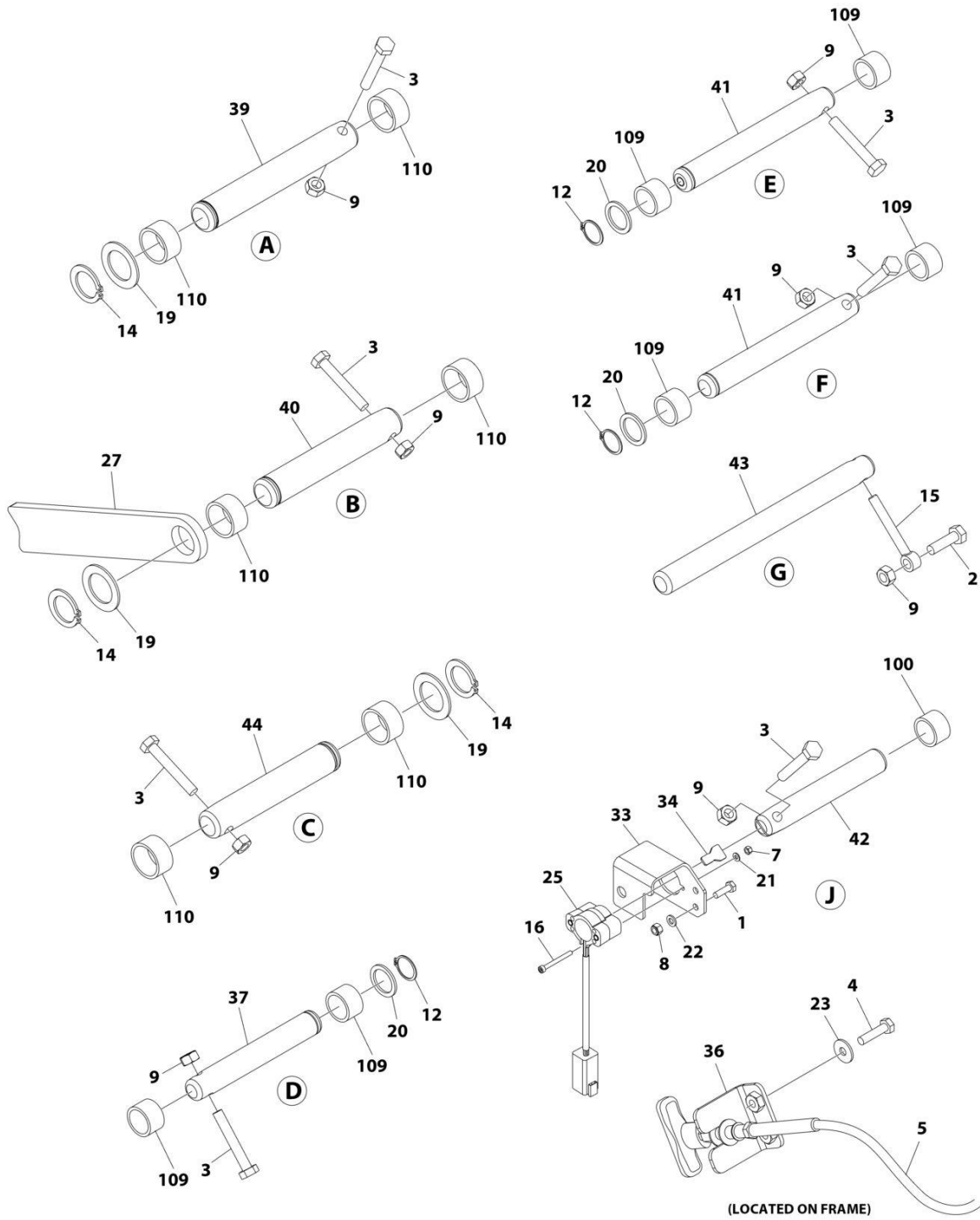

ART_1001276585_20F2

SECTION 3 - SCISSORS ARMS

FIGURE 3-7. SCISSORS ARMS INSTALLATION - R1932/R1932I (MACHINES WITH SN STARTING WITH G2)

ITEM	PART NUMBER	QTY	DESCRIPTION	REV
	1001276585	Ref	SCISSORS ARMS INSTALLATION	C
1	0700620	2	Bolt M6 x 60	
2	0701015	3	Bolt M10 x 35	
3	0701021	22	Bolt M10 x 65	
4	0760612	2	Bolt M6 x 25	
5	1061034	1	Cable, Manual Descent	
5	7020218	1	T-Handle (1/4 Threads)	
5	70001878	1	T-Handle (M5 Threads)	
6	2221116	1	Fitting, 90 ORB/ORB	
7	3290405	2	Nut M4	
8	3290605	2	Nut M6	
9	3291007	25	Nut M10	
10	3321402	1	Nut 1/4	
11	3340962	24	Pad	
12	3760115	12	Ring, Retaining	
13	3760170	4	Ring, Split	
14	3760387	8	Ring, Retaining	
15	3841143	2	Keeper, Pin	
16	4031512	2	Capscrew M4 x 40	
17	4160078	1	Spring	
18	4240017	5	Tie-Strap (Not Shown)	
19	4740438	8	Washer	
20	4740531	12	Washer	
21	4811400	2	Washer M4	
22	4811700	2	Washer M6	
23	4811702	2	Washer M6	
24	4812000	4	Washer M10	
25	1001295195	1	Sensor, Angle	
25	4460899	1	Receptacle, Female - 6 Position	
25	4460464	1	Pin, Male	
26	1001204311	2	Block, Slide	
27	1001204312	1	Plate, Prop	
28	1001206487	2	Support	
29	1001294256	1	Lift Down Harness (See Separate Breakdown in ELECTRICAL Section)	
31	1001225164	1	Transducer, Pressure	
32	1001226791	1	Bracket	
33	1001231268	1	Mount, Sensor	
34	1001234204	1	Key, Angle Sensor	
35	1001285320	1	Transducer, Pressure (3 Pin)	
35	1001235104	1	Transducer, Pressure (4 Pin)	
36	1001253153	1	Mount	
37	1001276707	7	Pin	
38	1001276725	1	Scissors Arms Kit (Not Shown) (Include Items 101-110)	
39	1001276728	4	Pin	
40	1001276729	1	Pin	
41	1001276730	6	Pin	
42	1001276731	1	Pin	
43	1001276732	2	Pin	

SECTION 3 - SCISSORS ARMS

ITEM	PART NUMBER	QTY	DESCRIPTION	REV
44	1001276733	3	Pin	
45	1001276734	1	Lift Cylinder Assembly (See Separate Breakdown in CYLINDER Section)	
100	1001134289	2	Bearing (Part of Frame)	
101	1001203973	1	Arm, Inboard Cylinder Mount	
102	1001203974	1	Arm, Inboard	
103	1001203975	1	Arm, Outboard	
104	1001203976	3	Arm, Outboard (Mid)	
105	1001204621	1	Arm, Outboard (Top)	
106	1001213554	1	Arm, Outboard (Mid)	
107	1001241604	1	Arm, Inboard Cylinder Mount (Lower)	
108	1001241605	1	Arm, Inboard (Upper)	
109	1001276726	28	Bearing	
110	1001276727	16	Bearing	

SECTION 3 - SCISSORS ARMS

FIGURE 3-8. SCISSORS ARMS INSTALLATION - R1932/R1932I (MACHINES WITH SN STARTING WITH M2) (SN M200060339 to Present)

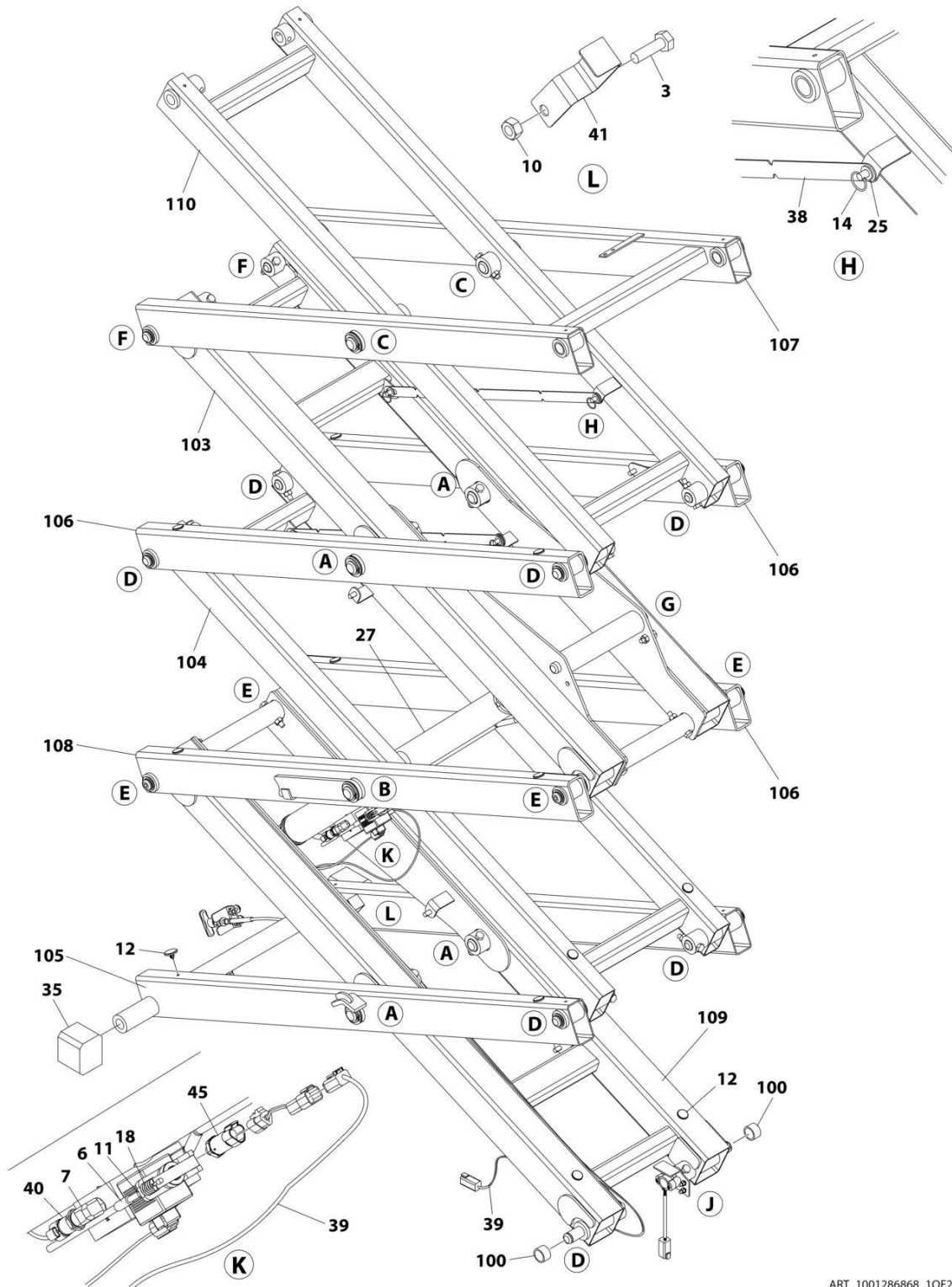

ART_1001286868_10F2

SECTION 3 - SCISSORS ARMS

FIGURE 3-9. SCISSORS ARMS INSTALLATION - R1932/R1932I (MACHINES WITH SN STARTING WITH M2) (SN M200060339 to Present)

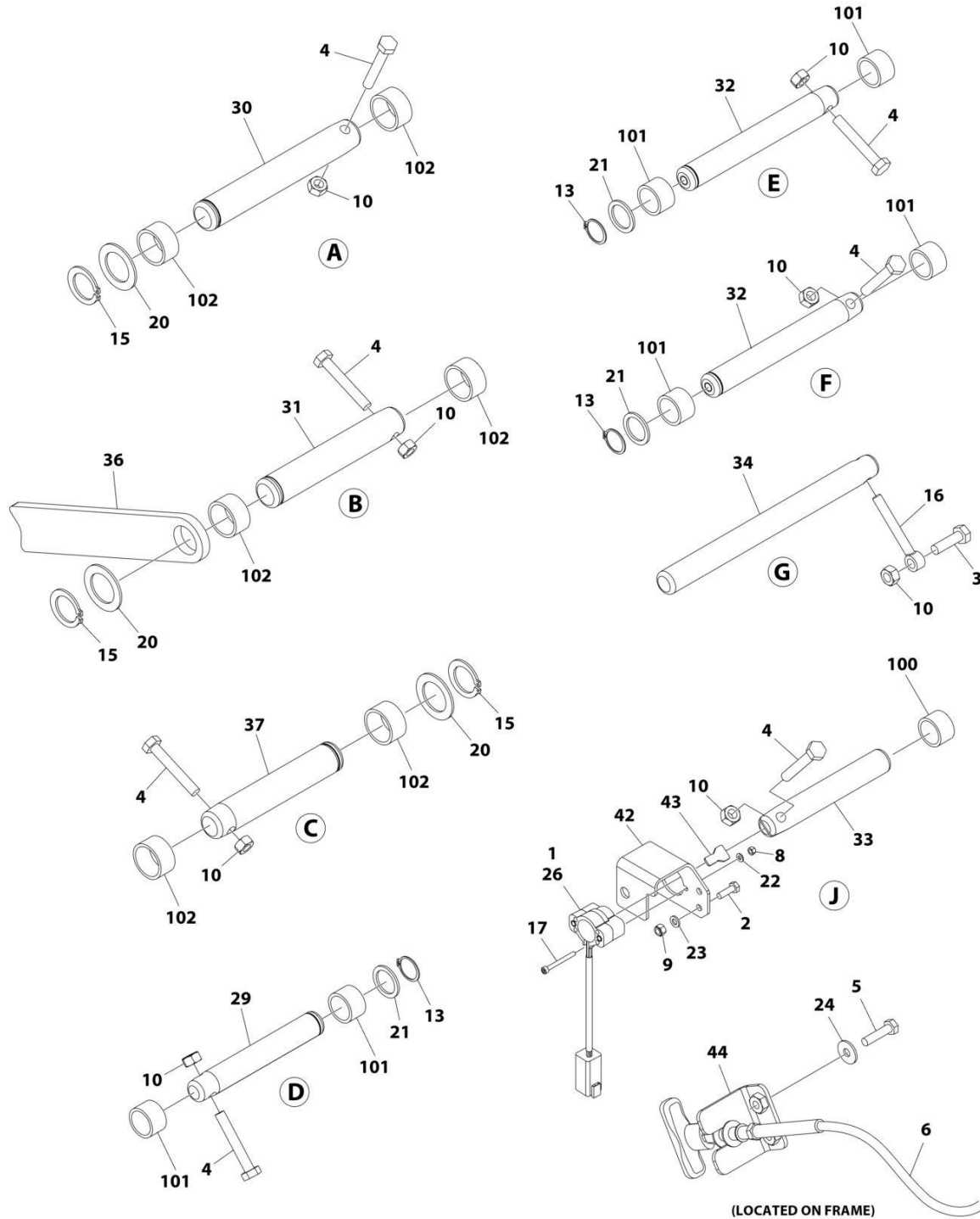

ART_1001286868_2OF2

SECTION 3 - SCISSORS ARMS

FIGURE 3-9. SCISSORS ARMS INSTALLATION - R1932/R1932I (MACHINES WITH SN STARTING WITH M2) (SN M200060339 to Present)

ITEM	PART NUMBER	QTY	DESCRIPTION	REV
	1001286868	Ref	SCISSORS ARMS INSTALLATION	A
1	280013	7 in/17cm	Conduit, Split	
2	0700620	2	Bolt M6 x 60	
3	0701015	3	Bolt M10 x 35	
4	0701021	22	Bolt M10 x 65	
5	0760612	2	Bolt M6 x 25	
6	1061034	1	Cable, Manual Descent	
7	2221116	1	Fitting, 90 ORB/ORB	
8	3290405	2	Nut M4	
9	3290605	2	Nut M6	
10	3291007	25	Nut M10	
11	3321402	1	Nut 1/4	
12	3340962	24	Pad	
13	3760115	12	Ring, Retaining	
14	3760170	4	Ring, Split	
15	3760387	8	Ring, Retaining	
16	3841143	2	Keeper, Pin	
17	4031512	2	Capscrew M4 x 40	
18	4160078	1	Spring	
19	4240017	AR	Tie-Strap (Not Shown)	
20	4740438	8	Washer	
21	4740531	12	Washer	
22	4811400	2	Washer M4	
23	4811700	2	Washer M6	
24	4811702	2	Washer M6	
25	4812000	4	Washer M10	
26	1001146963	1	Sensor, Angle	
27	1001198935	1	Cylinder, Lift (See Separate Breakdown in CYLINDER Section)	
28	1001201355	1	Scissors Arm Kit (Not Shown) (Includes Items 101-110)	
29	1001203443	7	Pin	
30	1001203444	4	Pin	
31	1001203445	1	Pin	
32	1001203446	6	Pin	
33	1001203447	1	Pin	
34	1001203448	2	Pin	
35	1001204311	2	Block, Slide	
36	1001204312	1	Plate, Prop	
37	1001204994	3	Pin	
38	1001206487	2	Support	
39	1001222687	1	Lift Down Harness (See Separate Breakdown in ELECTRICAL Section)	
40	1001225164	1	Transducer, Pressure	
41	1001226791	1	Bracket	
42	1001231268	1	Mount, Sensor	
43	1001234204	1	Key, Angle Sensor	
44	1001253153	1	Mount	
45	1001285320	1	Transducer, Pressure	
46	1001285829	1	Harness, Jumper (Not Shown) (See Separate Breakdown in ELECTRICAL Section)	

SECTION 3 - SCISSORS ARMS

ITEM	PART NUMBER	QTY	DESCRIPTION	REV
100	1001134289	2	Bearing (Part of Frame)	
101	0440264	28	Bearing	
102	0440265	16	Bearing	
103	1001203973	1	Arm, Inboard Cylinder Mount	
104	1001203974	1	Arm, Inboard	
105	1001203975	1	Arm, Outboard	
106	1001203976	3	Arm, Outboard (Mid)	
107	1001204621	1	Arm, Outboard (Top)	
108	1001213554	1	Arm, Outboard (Mid)	
109	1001241604	1	Arm, Inboard Cylinder Mount (Lower)	
110	1001241605	1	Arm, Inboard (Upper)	

SECTION 3 - SCISSORS ARMS

FIGURE 3-10. SCISSORS ARMS KIT - R1532I

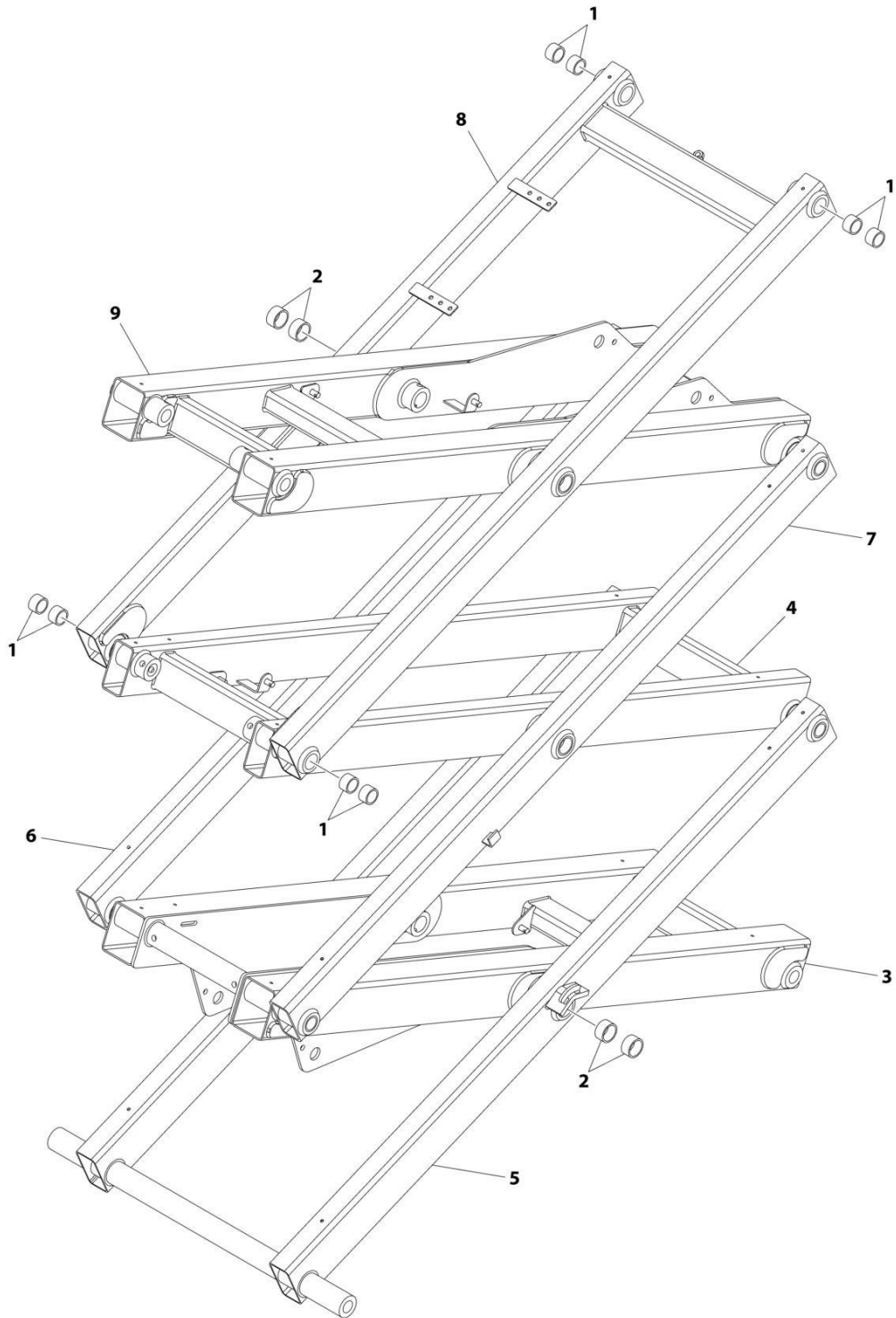

ART_1001235059

SECTION 3 - SCISSORS ARMS

FIGURE 3-10. SCISSORS ARMS KIT - R1532I

ITEM	PART NUMBER	QTY	DESCRIPTION	REV
	1001235059	Ref	SCISSORS ARMS KIT	B
1	0440264	20	Bearing	
2	0440265	12	Bearing	
3	1001235024	2	Arm, Inboard (Bottom)	
4	1001203974	1	Arm, Inboard (Mid)	
5	1001203975	1	Arm, Outboard (Bottom)	
6	1001203976	1	Arm, Outboard (Mid Left Side)	
7	1001213554	1	Arm, Outboard (Mid Right Side)	
8	1001204621	1	Arm, Outboard (Top)	
9	1001235025	1	Arm, Inboard (Top)	

SECTION 3 - SCISSORS ARMS

FIGURE 3-11. SCISSORS ARMS KIT - R1932/R1932I

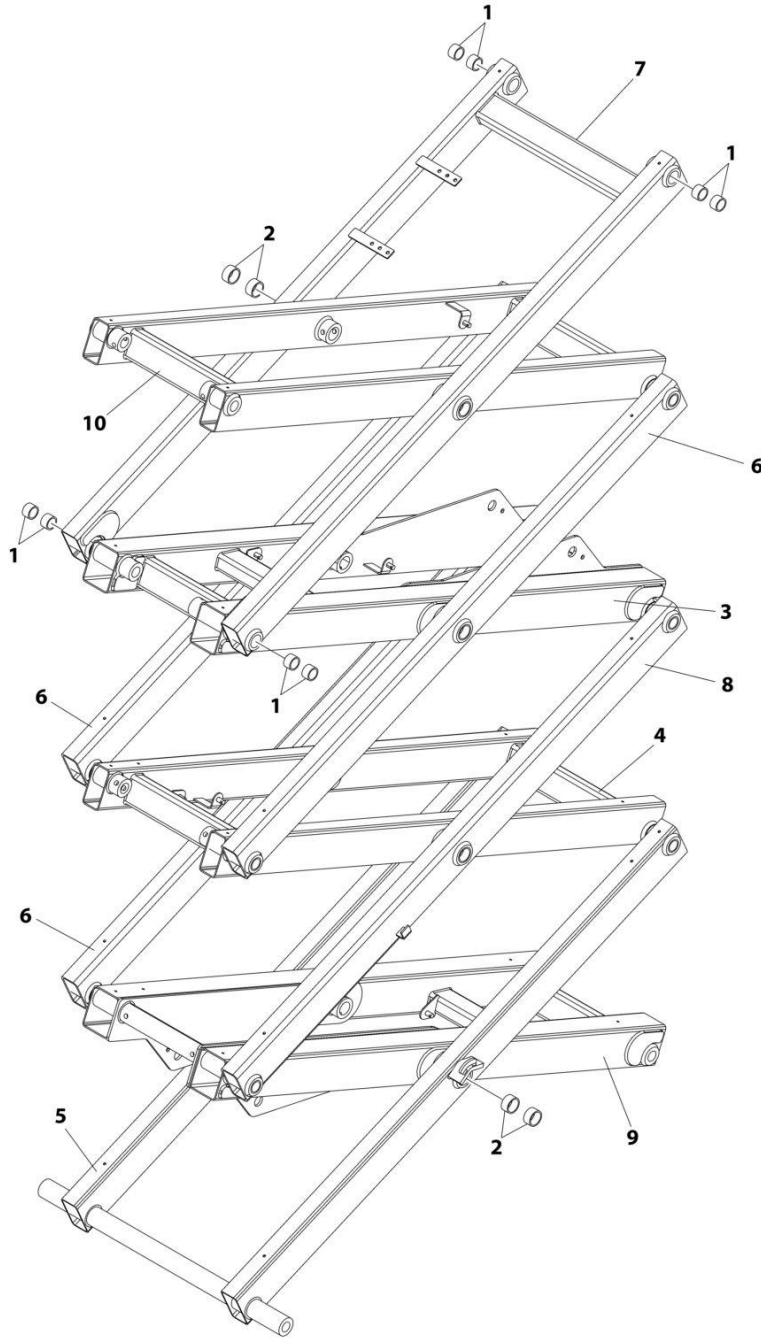

ART_1001201355_D

SECTION 3 - SCISSORS ARMS

FIGURE 3-11. SCISSORS ARMS KIT - R1932/R1932I

ITEM	PART NUMBER	QTY	DESCRIPTION	REV
	1001201355	Ref	SCISSORS ARMS KIT	D
1	0440264	28	Bearing	
2	0440265	16	Bearing	
3	1001203973	1	Arm, Inboard (Upper Mid)	
4	1001203974	1	Arm, Inboard (Lower Mid)	
5	1001203975	1	Arm, Outboard (Bottom)	
6	1001203976	3	Arm, Outboard (Lower Mid Left Side and Upper Mid Right/Left)	
7	1001204621	1	Arm, Outboard (Top)	
8	1001213554	1	Arm, Outboard (Lower Mid Right Side)	
9	1001241604	1	Arm, Inboard (Bottom)	
10	1001241605	1	Arm, Inboard (Top)	

SECTION 3 - SCISSORS ARMS

FIGURE 3-12. ARM GUARD INSTALLATION

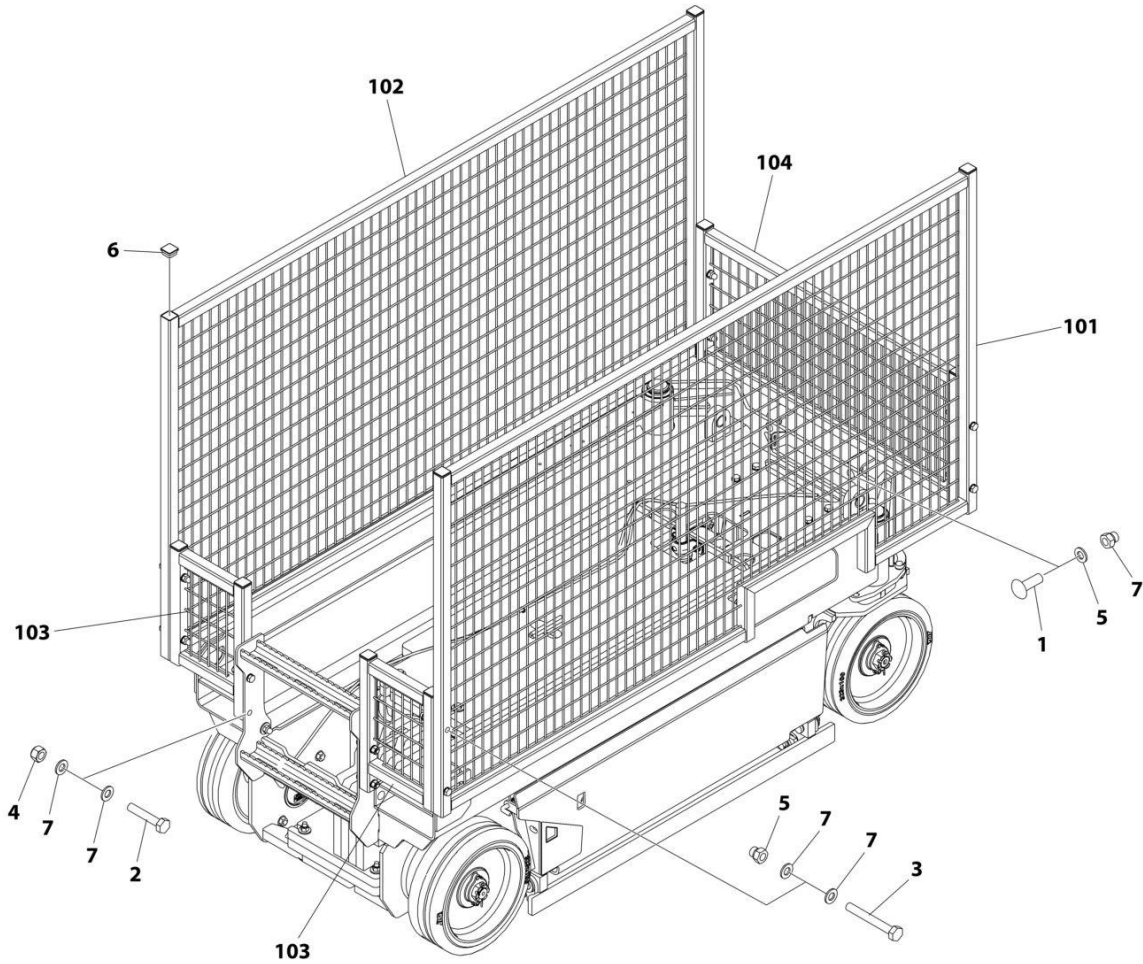

ART_1001224623

SECTION 3 - SCISSORS ARMS

FIGURE 3-12. ARM GUARD INSTALLATION

ITEM	PART NUMBER	QTY	DESCRIPTION	REV
	1001224623	Ref	ARM GUARD INSTALLATION	A
1	0630613	2	Bolt M10 x 30	
2	0701019	4	Bolt M10 x 55	
3	0701024	8	Bolt M10 x 80	
4	3291005	4	Nut M10	
5	3291006	10	Nut M10	
6	3520072	10	Plug	
7	4812000	26	Washer M10	
8	1001224622	1	Arm Guard Kit	
101	1001224604	1	Guard, Arm (RH)	
102	1001224608	1	Guard, Arm (LH)	
103	1001224614	2	Guard, Arm (Rear)	
104	1001224620	1	Guard, Arm (Front)	

SECTION 4 - PLATFORM

SECTION 4 - PLATFORM

FIGURE 4-1. PLATFORM INSTALLATION - R1532I

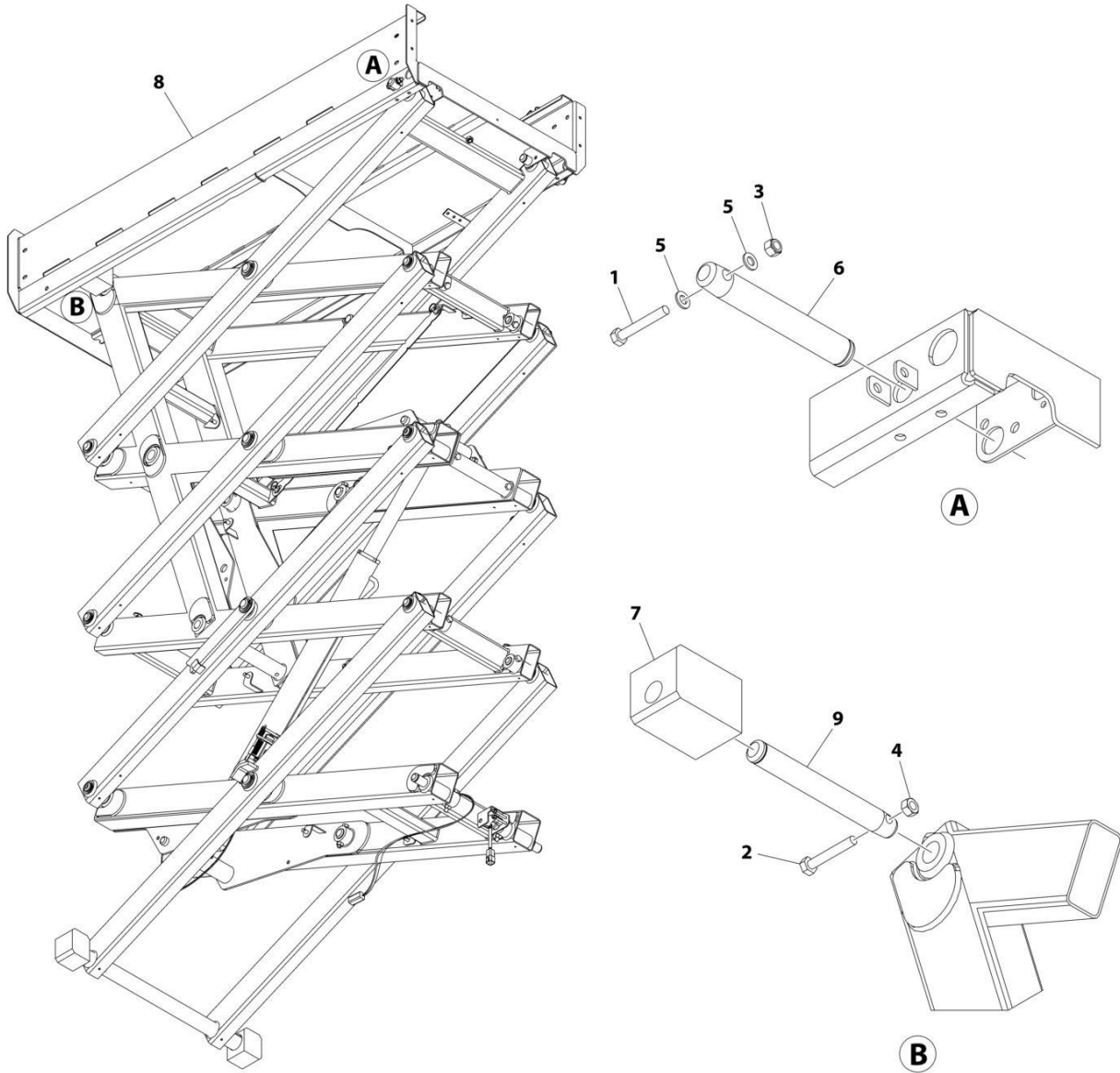

ART_1001226948

SECTION 4 - PLATFORM

FIGURE 4-1. PLATFORM INSTALLATION - R1532I

ITEM	PART NUMBER	QTY	DESCRIPTION	REV
	1001235018	Ref	PLATFORM INSTALLATION	A
1	0700819	2	Bolt M8 x 55	
2	0701021	2	Bolt M10 x 65	
3	3290805	2	Nut M8	
4	3291007	2	Nut M10	
5	4811900	4	Washer M8	
6	1001203443	2	Pin	
7	1001205156	2	Block, Slide	
8	1001235541	1	Platform	
9	1001204781	2	Pin	

SECTION 4 - PLATFORM

FIGURE 4-2. PLATFORM INSTALLATION - R1932/R1932I

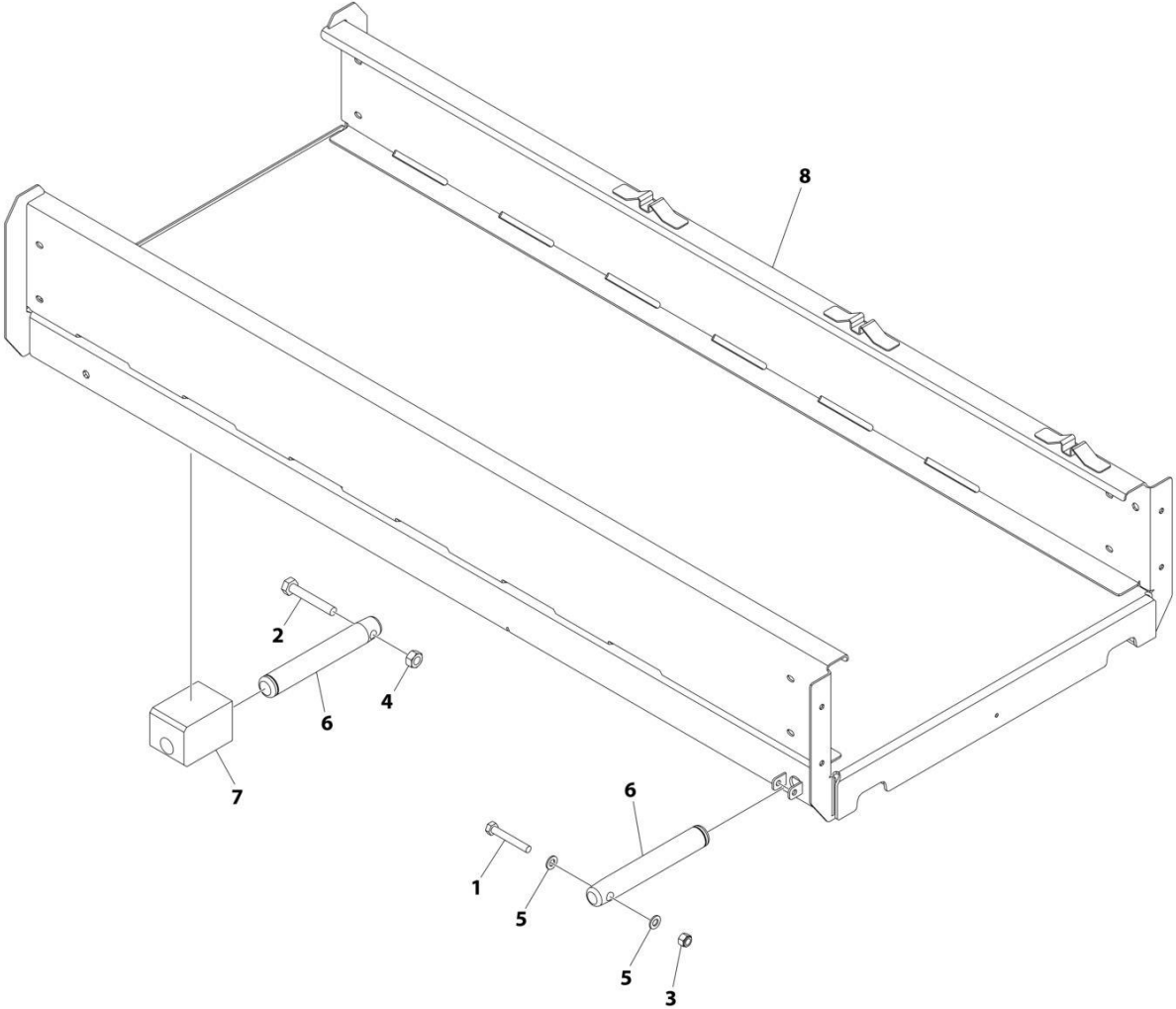

ART_1001205709_C

SECTION 4 - PLATFORM

FIGURE 4-2. PLATFORM INSTALLATION - R1932/R1932I

ITEM	PART NUMBER	QTY	DESCRIPTION	REV
	1001205709	Ref	PLATFORM INSTALLATION	C
1	0700819	2	Bolt M8 x 55	
2	0701021	2	Bolt M10 x 65	
3	3290805	2	Nut M8	
4	3291007	2	Nut M10	
5	4811900	4	Washer M8	
6	1001203443	4	Pin	
7	1001205156	2	Block, Slide	
8	1001235541	1	Platform	

SECTION 4 - PLATFORM

FIGURE 4-3. PLATFORM INSTALLATION (MACHINES WITH SN STARTING WITH G2)

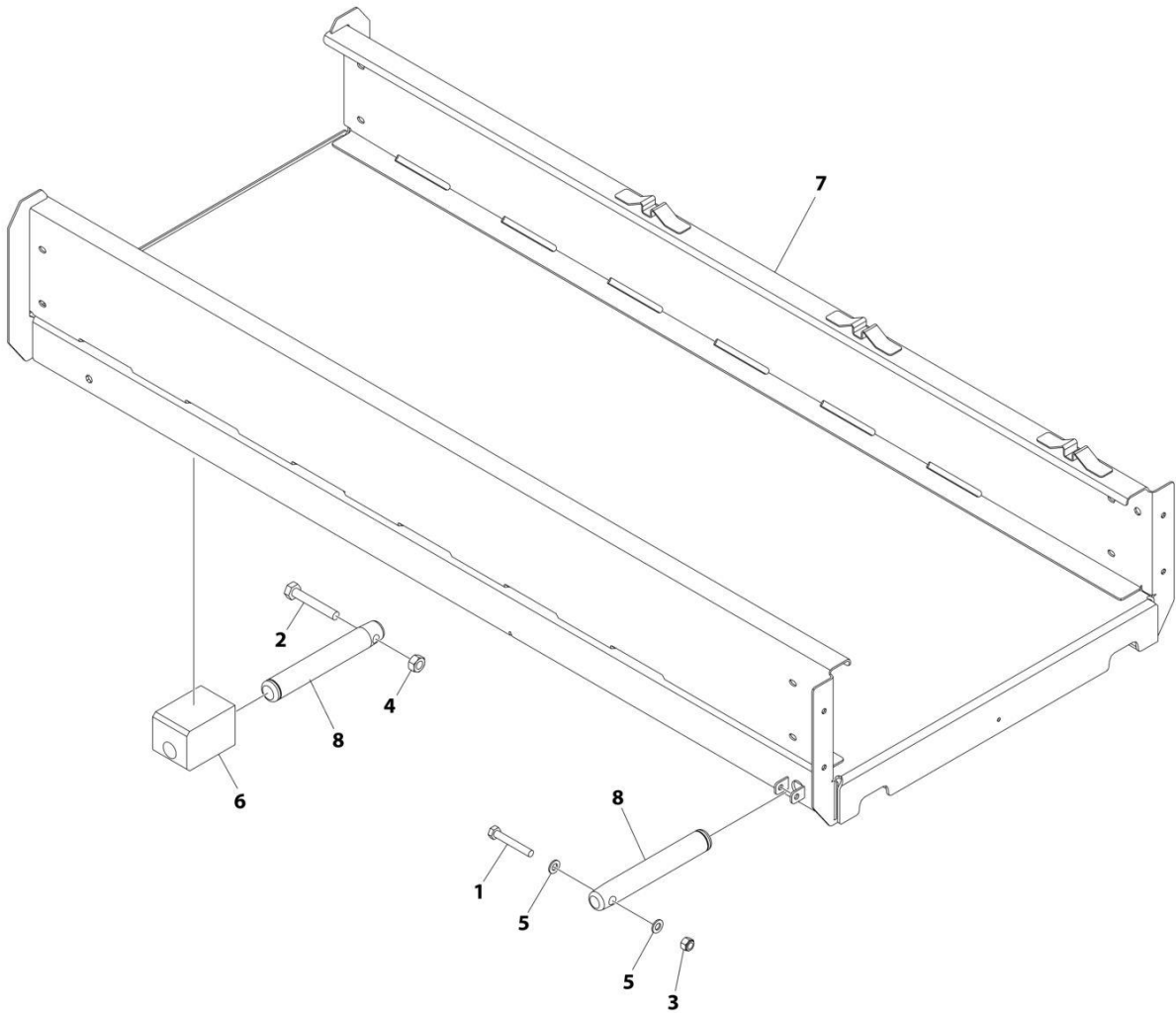

ART_1001276705

SECTION 4 - PLATFORM

FIGURE 4-3. PLATFORM INSTALLATION (MACHINES WITH SN STARTING WITH G2)

ITEM	PART NUMBER	QTY	DESCRIPTION	REV
	1001276705	Ref	PLATFORM INSTALLATION	A
1	0700819	2	Bolt M8 x 55	
2	0701021	2	Bolt M10 x 65	
3	3290805	2	Nut M8	
4	3291007	2	Nut M10	
5	4811900	4	Washer M8	
6	1001205156	2	Block, Slide	
7	1001235541	1	Platform	
8	1001276707	4	Pin	

SECTION 4 - PLATFORM

FIGURE 4-4. PLATFORM EXTENSION INSTALLATION

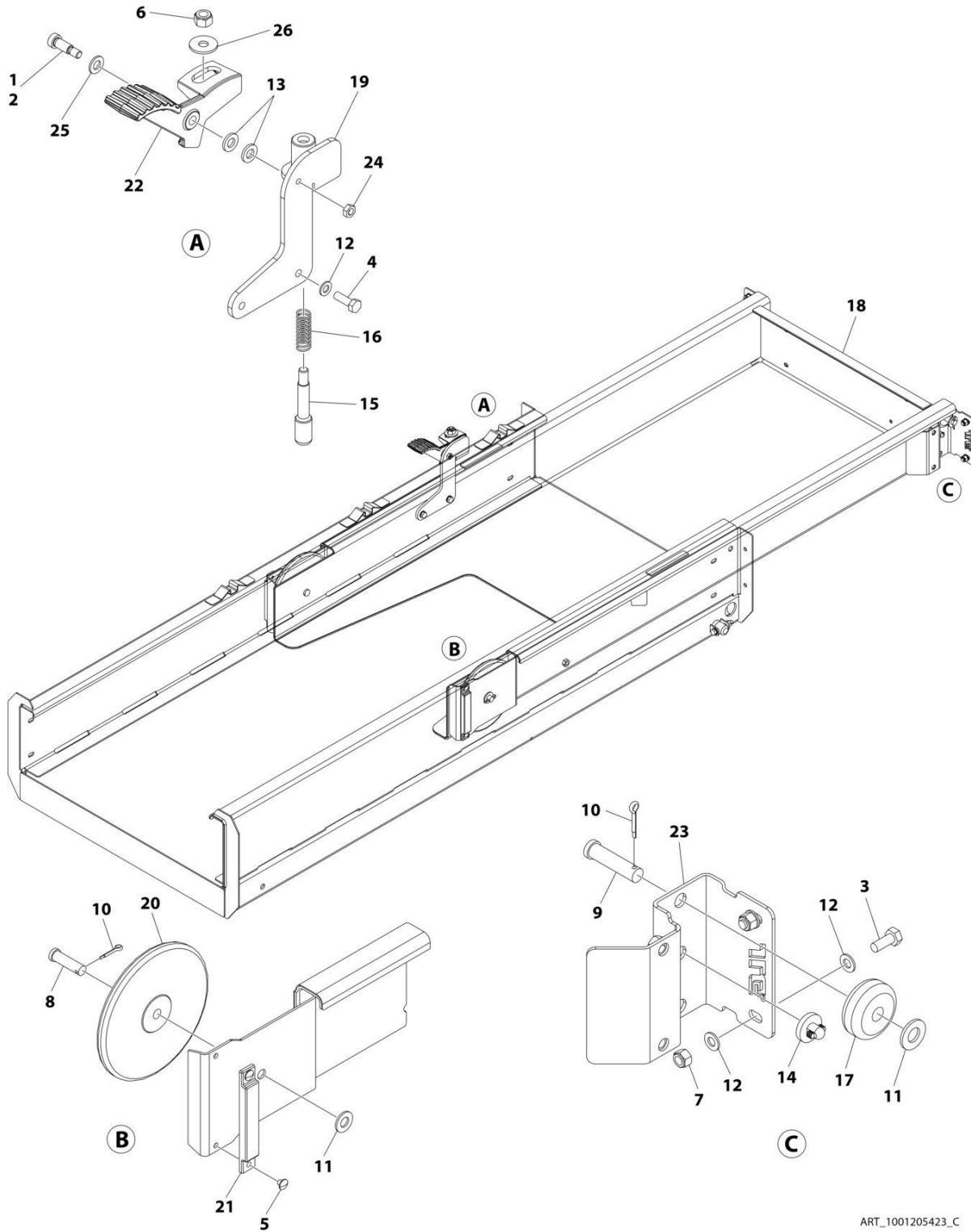

ART_1001205423_C

SECTION 4 - PLATFORM

FIGURE 4-4. PLATFORM EXTENSION INSTALLATION

ITEM	PART NUMBER	QTY	DESCRIPTION	REV
	1001205423	Ref	PLATFORM EXTENSION INSTALLATION	C
1	0100011	AR	Compound, Locking	
2	0630183	1	Screw 3/8 x 1	
3	0760810	4	Bolt M8 x 20	
4	0760812	2	Bolt M8 x 25	
5	2080040	4	Fastener	
6	3290605	AR	Nut M6	
6	3291005	AR	Nut M10	
7	3290805	4	Nut M8	
8	3430814	2	Pin	
9	3430816	2	Pin	
10	3450403	4	Pin, Cotter 1/8 x 3/4	
11	4711800	4	Washer 1/2	
12	4811900	11	Washer M8	
13	5241000	5	Washer M10	
14	1001137675	2	Bumper	
15	1001221476	1	Rod	
16	1001221475	1	Spring	
17	1001205422	2	Roller (Front)	
18	1001205424	1	Extension, Platform	
19	1001236129	1	Bracket	
20	1001205430	2	Roller (Rear)	
21	1001208852	2	Pad	
22	1001217043	1	Plate	
23	1001210064	2	Support	
24	3311502	1	Nut 5/16	
25	4812000	AR	Washer M10	
26	4812002	AR	Washer M10	

SECTION 4 - PLATFORM

FIGURE 4-5. RAILS INSTALLATION - FIXED RAILS/GATE ENTRY (INSIDE TUBE SLIDER)

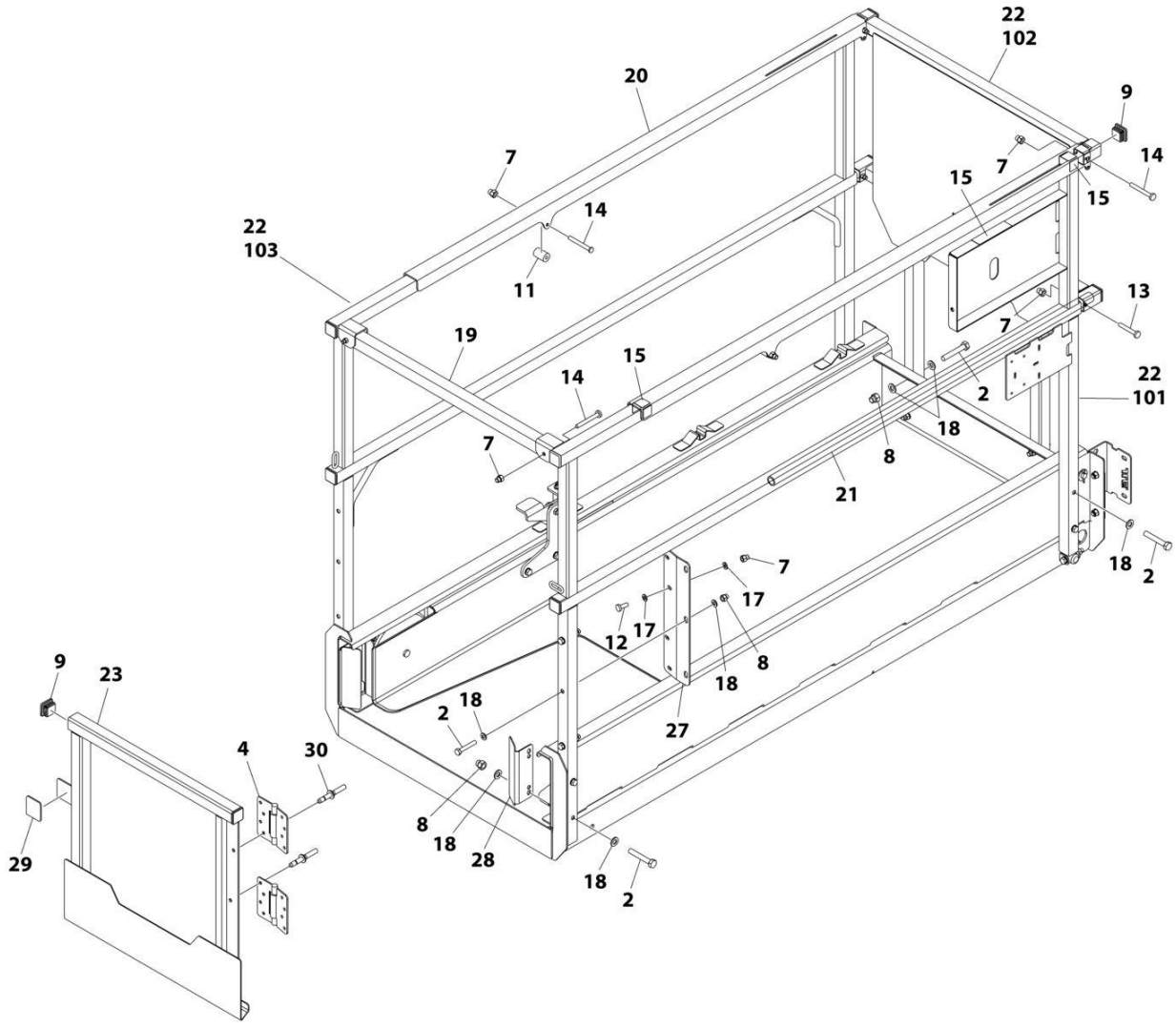

ART_1001207806_F

SECTION 4 - PLATFORM

FIGURE 4-5. RAILS INSTALLATION - FIXED RAILS/GATE ENTRY (INSIDE TUBE SLIDER)

ITEM	PART NUMBER	QTY	DESCRIPTION	REV
	1001207806	Ref	RAILS INSTALLATION - FIXED RAILS/GATE ENTRY (INSIDE TUBE SLIDER)	F
2	0700818	15	Bolt M8 x 50	
4	2600281	2	Hinge	
7	3290606	12	Nut M6	
8	3290806	11	Nut M8	
9	3520072	10	Plug	
11	3860111	2	Roller	
12	4010608	4	Screw M6 x 16	
13	4010616	2	Screw M6 x 40	
14	4010618	6	Screw M6 x 50	
15	4420062	1.3 ft/ 40cm	Tape	
17	4811700	8	Washer M6	
18	4811900	28	Washer M8	
19	1001206224	1	Tube (Rear)	
20	1001206225	2	Rail, Top Slide	
21	1001206226	2	Rod	
22	1001206228	1	Rail Kit - Fixed Rails (See Items 101-103 for Breakdown))	
23	1001210302	1	Gate	
27	1001210586	1	Plate, Gate Hinge	
28	1001210963	2	Cover	
29	3080007	1	Magnet, Latch	
30	2080040	4	Fastener	
	1001206228	Ref	RAIL KIT - FIXED RAILS	H
101	1001206207	1	Rail, Side	
102	1001206217	1	Rail, Front	
103	1001206222	1	Rail, Side	

SECTION 4 - PLATFORM

FIGURE 4-6. RAIL KIT - FIXED RAILS (INSIDE TUBE SLIDER)

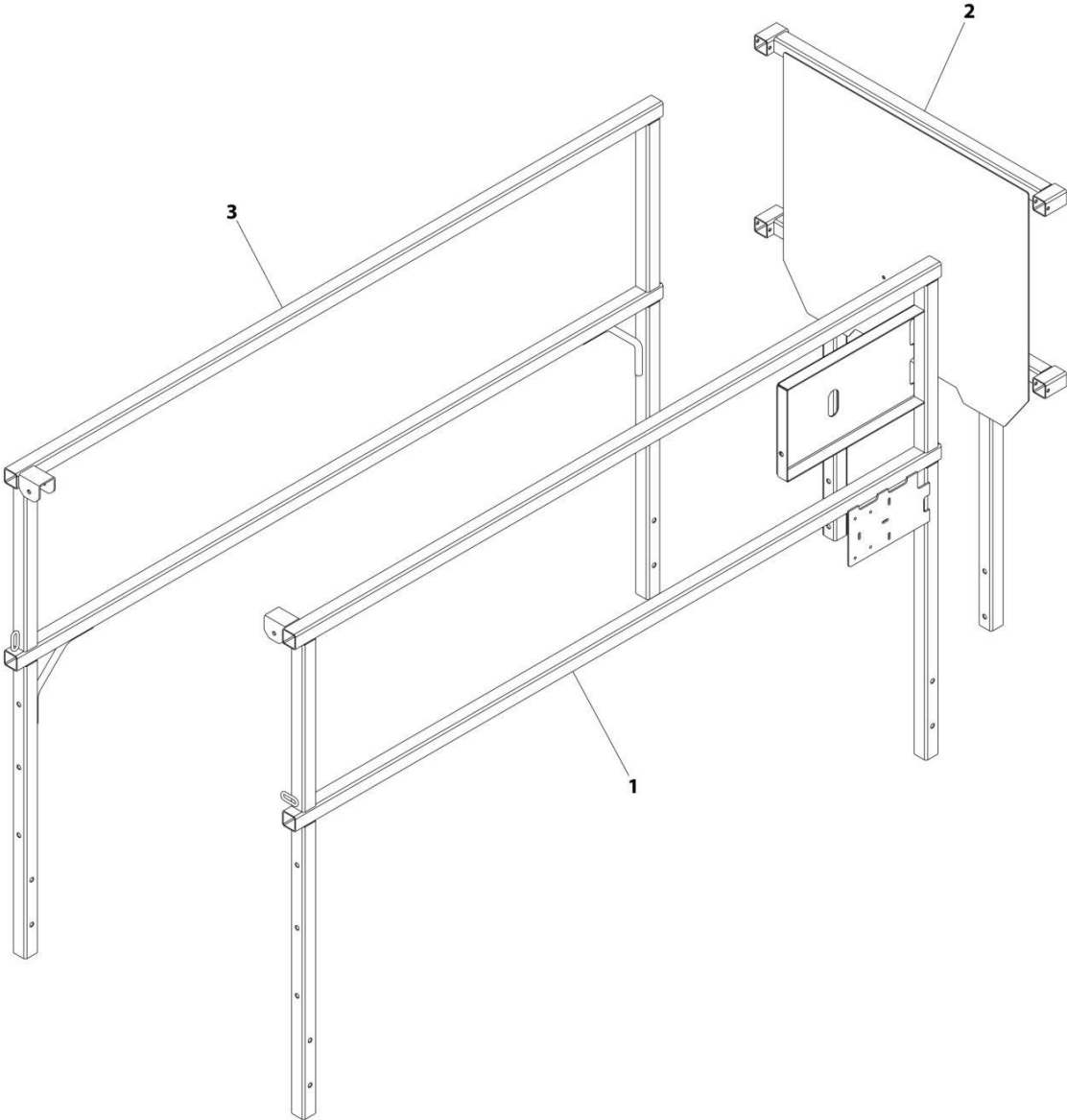

ART_1001206228

SECTION 4 - PLATFORM

FIGURE 4-6. RAIL KIT - FIXED RAILS (INSIDE TUBE SLIDER)

ITEM	PART NUMBER	QTY	DESCRIPTION	REV
	1001206228	Ref	RAIL KIT - FIXED RAILS (INSIDE TUBE SLIDER)	H
1	1001206207	1	Rail (Right)	
2	1001206217	1	Rail Extension (Front)	
3	1001206222	1	Rail (Left)	

SECTION 4 - PLATFORM

FIGURE 4-7. RAILS INSTALLATION - FOLD-DOWN RAILS/GATE ENTRY (INSIDE TUBE SLIDER)

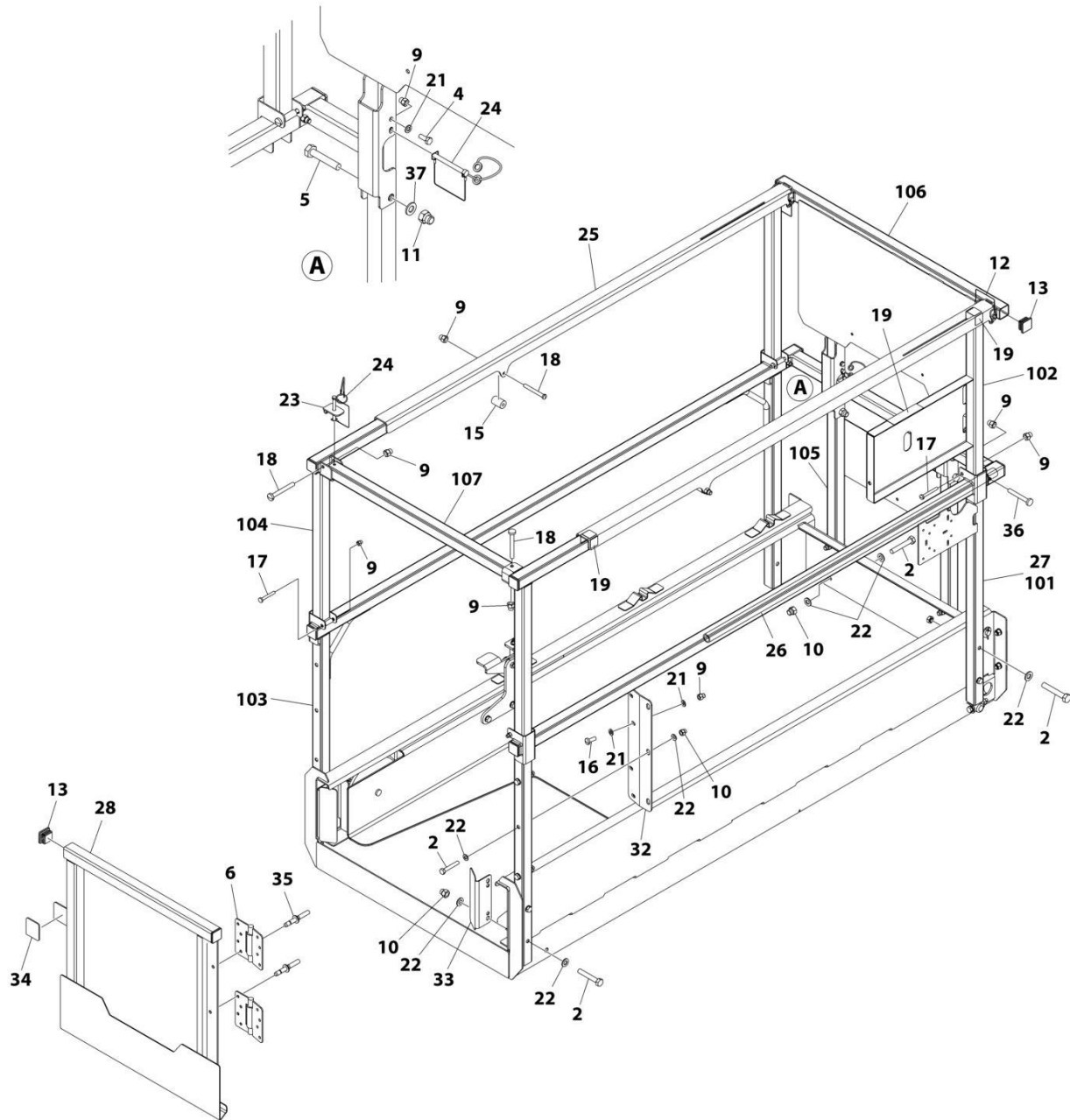

ART_1001207807_E

SECTION 4 - PLATFORM

FIGURE 4-7. RAILS INSTALLATION - FOLD-DOWN RAILS/GATE ENTRY (INSIDE TUBE SLIDER)

ITEM	PART NUMBER	QTY	DESCRIPTION	REV
	1001207807	Ref	RAILS INSTALLATION - FOLD-DOWN RAILS/GATE ENTRY (INSIDE TUBE SLIDER)	E
2	0700818	15	Bolt M8 x 50	
4	0760608	2	Bolt M6 x 16	
5	0761019	2	Bolt M10 x 55	
6	2600281	2	Hinge	
9	3290606	16	Nut M6	
10	3290806	11	Nut M8	
11	3291006	2	Nut M10	
12	3422219	2	Pin	
13	3520072	10	Plug	
15	3860111	2	Roller	
16	4010608	4	Screw M6 x 16	
17	4010617	4	Screw M6 x 45	
18	4010618	4	Screw M6 x 50	
19	4420062	1.3 ft/ 40cm	Tape	
21	4811700	10	Washer M6	
22	4811900	26	Washer M8	
23	1001154378	1	Bracket	
24	1001187587	3	Pin	
25	1001206225	2	Rail, Top Slide	
26	1001206226	2	Rod	
27	1001208073	1	Rail Kit - Fold-Down Rails (Includes Items 101-107)	
28	1001210302	1	Gate	
32	1001210586	1	Plate, Gate Hinge	
33	1001210963	2	Cover	
34	3080007	1	Magnet	
35	2080040	4	Fastener	
36	4010616	4	Screw M6 x 40	
37	4812000	2	Washer M10	
101	1001210442	1	Rail - Lower (Right)	
102	1001210443	1	Rail - Upper (Right)	
103	1001210444	1	Rail - Lower (Left)	
104	1001210445	1	Rail - Upper (Left)	
105	1001210446	1	Rail - Extension Lower (Front)	
106	1001210447	1	Rail - Extension Upper (Front)	
107	1001210458	1	Rail (Rear)	

SECTION 4 - PLATFORM

FIGURE 4-8. RAIL KIT - FOLD-DOWN RAILS (INSIDE TUBE SLIDER)

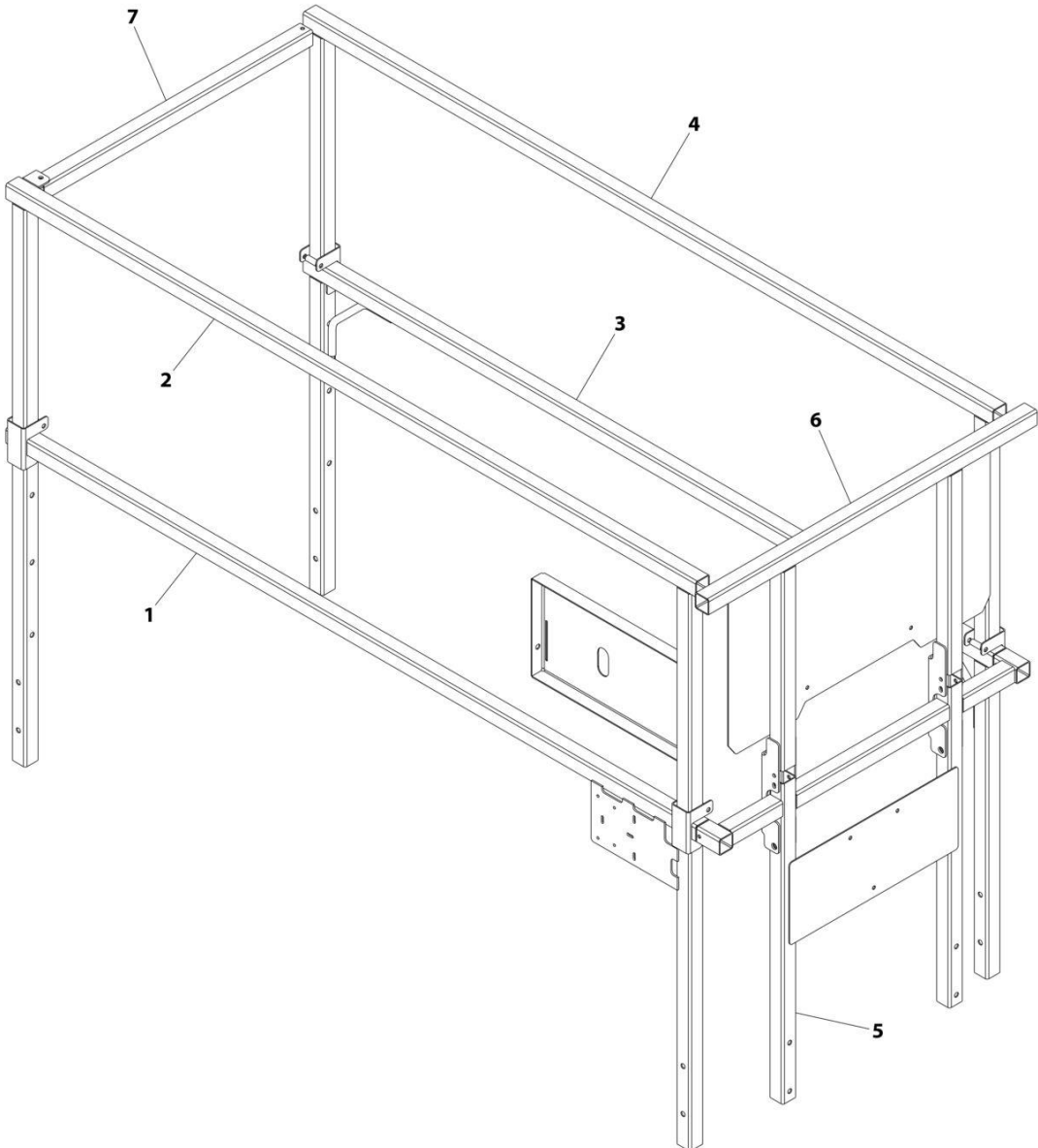

ART_1001208073

SECTION 4 - PLATFORM

FIGURE 4-8. RAIL KIT - FOLD-DOWN RAILS (INSIDE TUBE SLIDER)

ITEM	PART NUMBER	QTY	DESCRIPTION	REV
	1001208073	Ref	RAIL KIT - FOLD-DOWN RAILS (INSIDE TUBE SLIDER)	B
1	1001210442	1	Rail - Lower (Right)	
2	1001210443	1	Rail - Upper (Right)	
3	1001210444	1	Rail - Lower (Left)	
4	1001210445	1	Rail - Upper (Left)	
5	1001210446	1	Rail - Extension Lower (Front)	
6	1001210447	1	Rail - Extension Upper (Front)	
7	1001210458	1	Rail (Rear)	

SECTION 4 - PLATFORM

FIGURE 4-9. RAILS INSTALLATION - FOLD-DOWN RAILS/GATE ENTRY (QUIK FOLD) (INSIDE TUBE SLIDER) (ALL SPECS EXCEPT AUSTRALIAN, CE, KOREAN & UK CA SPECS)

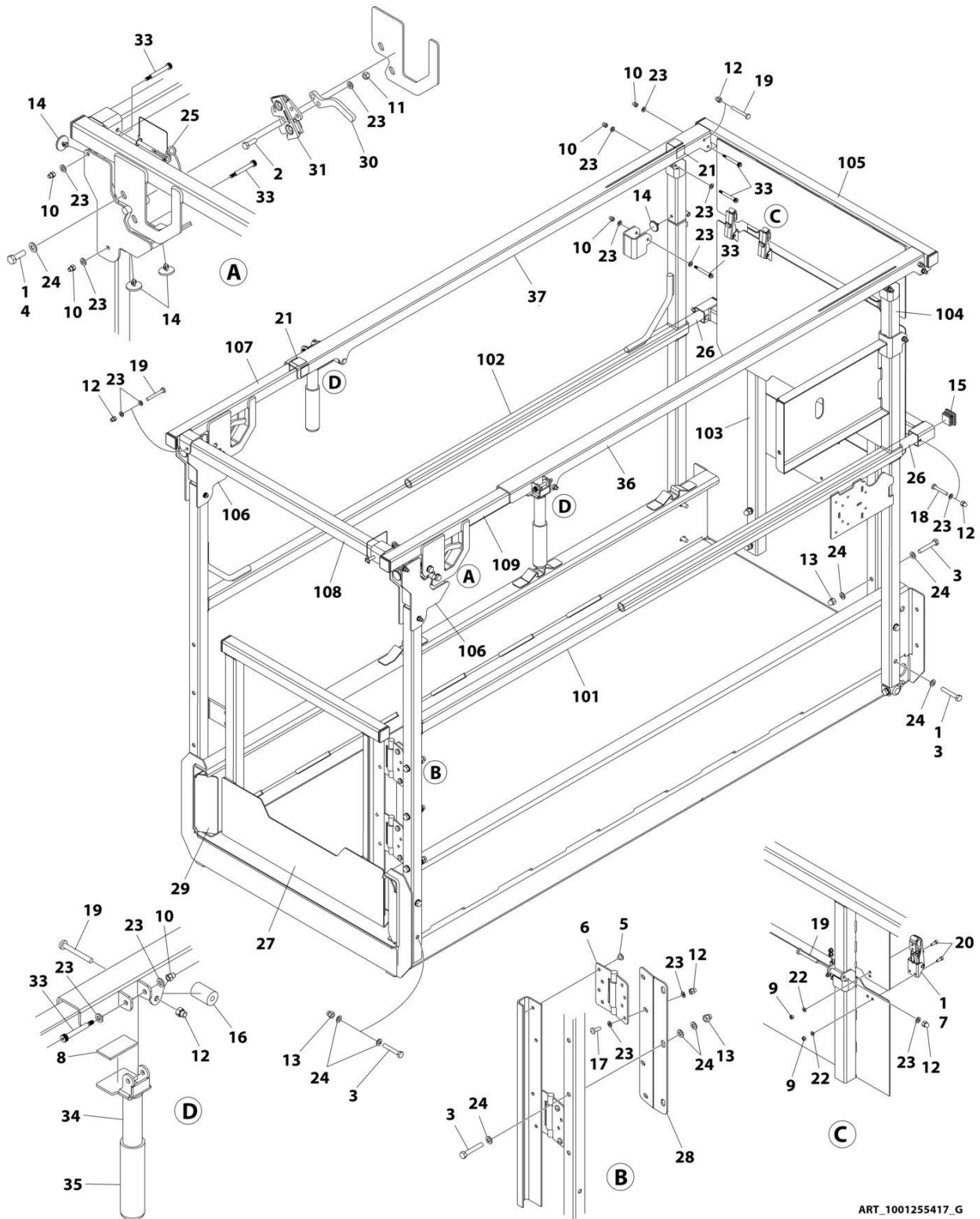

ART_1001255417_G

SECTION 4 - PLATFORM

FIGURE 4-9. RAILS INSTALLATION - FOLD-DOWN RAILS/GATE ENTRY (QUIK FOLD) (INSIDE TUBE SLIDER) (ALL SPECS EXCEPT AUSTRALIAN, CE, KOREAN & UK CA SPECS)

ITEM	PART NUMBER	QTY	DESCRIPTION	REV
	1001255417	Ref	RAILS INSTALLATION - FOLD-DOWN RAILS/GATE ENTRY (QUIK FOLD) (INSIDE TUBE SLIDER)	G
1	0100011	AR	Compound, Locking	
2	0700610	4	Bolt M6 x 20	
3	0700818	15	Bolt M8 x 50	
4	0700812	4	Bolt M8 x 25	
5	2080040	4	Fastener	
6	2600281	2	Hinge	
7	1001286736	2	Latch	
8	3080007	3	Magnet	
9	3290405	8	Nut, Lock M4	
10	3290506	12	Nut M5	
11	3290605	4	Nut, Lock M6	
12	3290606	13	Nut M6	
13	3290806	11	Nut M8	
14	3340962	8	Pad	
15	3520072	10	Plug	
16	3860111	2	Roller	
17	4010608	4	Screw M6 x 16	
18	4010616	2	Screw M6 x 40	
19	4010618	7	Screw M6 x 50	
20	4031506	8	Bolt M4 x 12	
21	4420062	1 ft /30cm	Tape	
22	4811400	8	Washer M4	
23	4811700	42	Washer M6	
24	4811900	33	Washer M8	
25	1001187587	1	Pin	
26	1001206226	2	Rod	
27	1001210302	1	Gate	
28	1001210586	1	Plate, Gate Hinge	
29	1001210963	2	Cover	
30	1001259102	1	Plate, Latch Trigger	
31	1001255470	1	Latch Assembly	
33	1001256657	12	Bolt M6 x 40	
34	1001282613	2	Handle	
35	2560088	2	Grip, Handle	
36	1001282611	1	Rail, Top Right Slide	
37	1001282612	1	Rail, Top Left Slide	
100	1001255420	1	Rail Kit (Not Shown)	H
101	1001255421	1	Rail (Right Platform)	
102	1001255428	1	Rail (Left Platform)	
103	1001255430	1	Rail (Platform Extension)	
104	1001255442	2	Tube (Rail Hinge)	
105	1001255457	1	Rail (Upper Extension)	
106	1001259105	2	Rail (Latch Assembly)	
107	1001259106	1	Rail (Upper)	
108	1001255491	1	Tube (Upper Extension)	
109	1001259107	1	Rail (Upper)	

SECTION 4 - PLATFORM

FIGURE 4-10. RAILS INSTALLATION - FOLD-DOWN RAILS/GATE ENTRY (QUIK FOLD) (INSIDE TUBE SLIDER) (CE & UK CA SPECS)

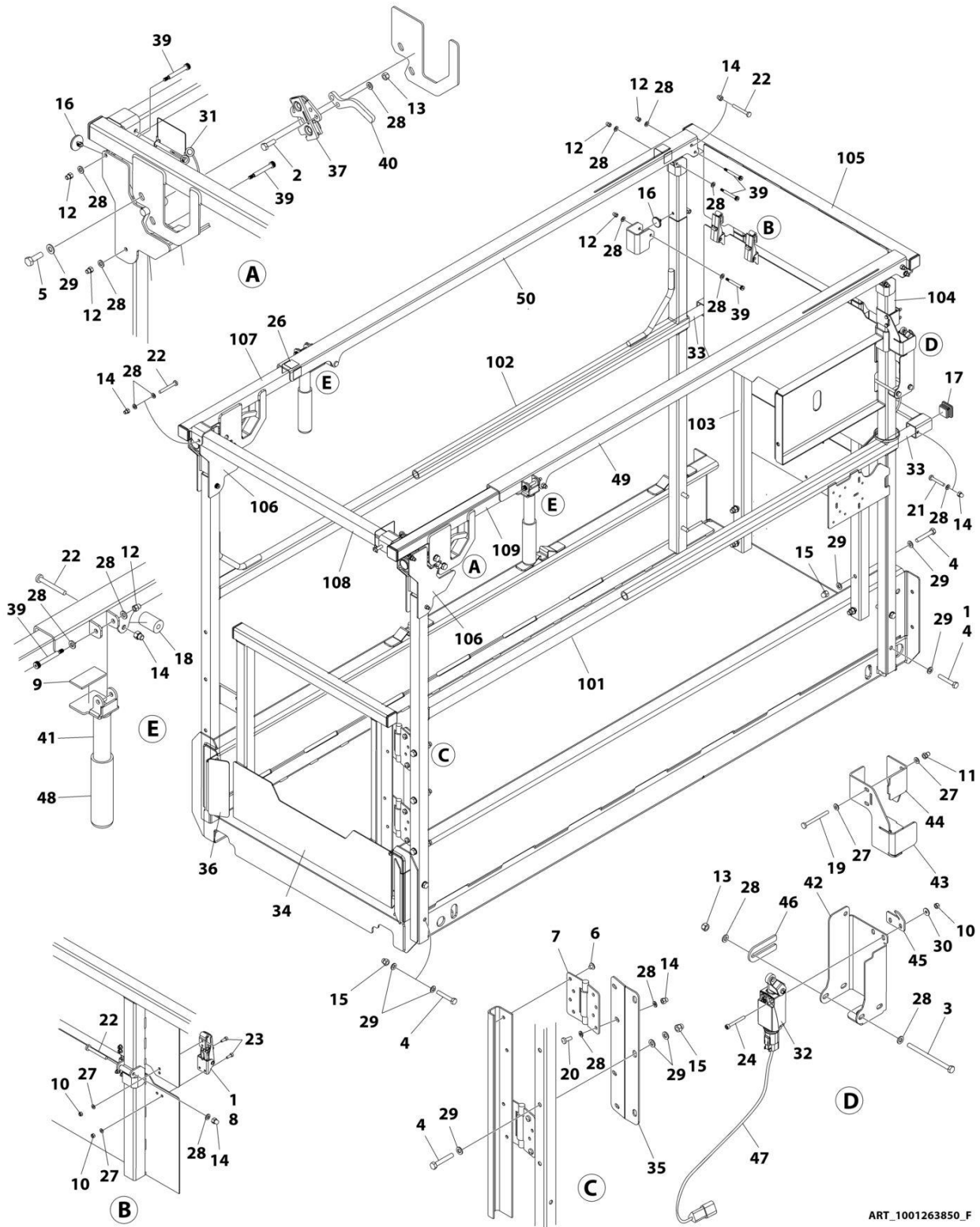

ART_1001263850_F

SECTION 4 - PLATFORM

FIGURE 4-10. RAILS INSTALLATION - FOLD-DOWN RAILS/GATE ENTRY (QUIK FOLD) (INSIDE TUBE SLIDER) (CE & UK CA SPECS)

ITEM	PART NUMBER	QTY	DESCRIPTION	REV
	1001263850	Ref	RAIL INSTALLATION	F
1	0100011	AR	Compound, Locking	
2	0700610	4	Bolt M6 x 20	
3	0700626	2	Bolt M6 x 90	
4	0700818	15	Bolt M8 x 50	
5	0760812	4	Bolt M8 x 25	
6	2080040	4	Fastener	
7	2600281	2	Hinge	
8	1001286736	2	Latch	
9	3080007	3	Magnet Gate	
10	3290405	10	Nut, Lock M4	
11	3290406	2	Nut M4	
12	3290506	12	Nut M5	
13	3290605	6	Nut, Lock M6	
14	3290606	13	Nut M6	
15	3290806	11	Nut M8	
16	3340962	8	Pad	
17	3520072	10	Plug	
18	3860111	2	Roller	
19	4010417	2	Screw M4 x 45	
20	4010608	4	Screw M6 x 16	
21	4010616	2	Screw M6 x 40	
22	4010618	7	Screw M6 x 50	
23	4031506	8	Capscrew M4 x 12	
24	4031511	2	Capscrew M4 x 35	
25	4240017	AR	Tie-Strap (Not Shown)	
26	4420062	1 ft /30 cm	Tape	
27	4811400	12	Washer M4	
28	4811700	46	Washer M6	
29	4811900	33	Washer M8	
30	1001091102	2	Washer M4	
31	1001187587	1	Pin With Lanyard	
32	1001203871	1	Switch, Limit	
33	1001206226	2	Rod	
34	1001210302	1	Gate	
35	1001210586	1	Support	
36	1001210963	2	Cover	
37	1001255470	2	Latch	
39	1001256657	12	Bolt M6 x 40	
40	1001259102	2	Plate, Latch	
41	1001282613	2	Handle, Lock	
42	1001263805	1	Mount	
43	1001279476	1	Plate	
44	1001279477	1	Clamp	
45	1001263808	1	Guard	
46	1001264079	1	Shim	
47	1001264110	1	Harness, Quick FD Rail Switch	
47	4460844	1	Plug, Male - 4 Position (SN238 - Rail Switch)	
47	4460465	3	Socket, Female	

SECTION 4 - PLATFORM

ITEM	PART NUMBER	QTY	DESCRIPTION	REV
47	4460466	1	Plug Terminal	H
47	4460536	1	Receptacle, Female - 4 Position (SW475 - Platform Cable Connector)	
47	4460464	3	Pin, Male	
47	4460466	1	Plug, Terminal	
48	2560088	2	Grip, Handle	
49	1001282611	1	Rail, Top Right Slide	
50	1001282612	1	Rail, Top Left Slide	
100	1001255420	Ref	Rail Kit (Not Shown)	
101	1001255421	1	Rail (RH)	
102	1001255428	1	Rail (LH)	
103	1001255430	1	Rail (Extension Front Lower)	
104	1001255442	2	Rail (Front)	
105	1001255457	1	Rail (Extension Front Upper)	
106	1001259105	2	Latch	
107	1001259106	1	Rail (Top Inner RH)	
108	1001255491	1	Tube (Extension Top)	
109	1001259107	1	Rail (Top Inner LH)	

SECTION 4 - PLATFORM

FIGURE 4-11. RAILS INSTALLATION - FOLD-DOWN RAILS/GATE ENTRY (OUTSIDE TUBE SLIDER)
(ANSI EXPORT AND CHINA SPECS)

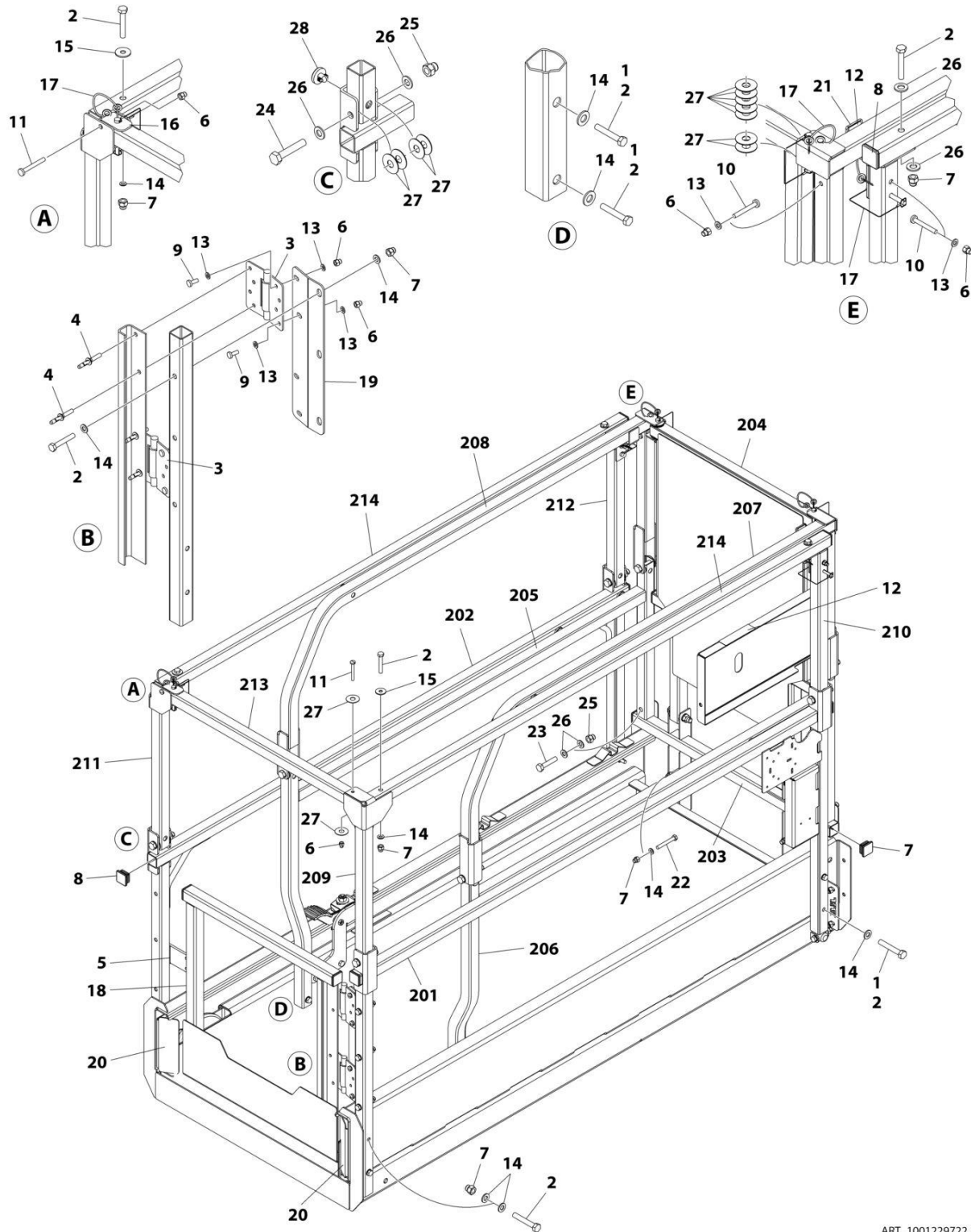

ART_1001229722_E

SECTION 4 - PLATFORM

**FIGURE 4-11. RAILS INSTALLATION - FOLD-DOWN RAILS/GATE ENTRY (OUTSIDE TUBE SLIDER)
(ANSI EXPORT AND CHINA SPECS)**

ITEM	PART NUMBER	QTY	DESCRIPTION	REV
	1001229722	Ref	RAILS INSTALLATION - FOLD-DOWN RAILS/GATE ENTRY	E
1	0100011	AR	Compound, Locking	
2	0700818	AR	Bolt M8 x 50	
3	2600281	2	Hinge	
4	2080040	4	Fastener	
5	3080007	1	Magnet	
6	3290606	10	Nut M6	
7	3290806	15	Nut M8	
8	3520072	12	Plug	
9	4010608	4	Screw M6 x 16	
10	4010617	4	Screw M6 x 45	
11	4010618	2	Screw M6 x 50	
12	4420062	15 in/ 37cm	Tape	
13	4811700	12	Washer M6	
14	4811900	28	Washer M8	
15	4811902	2	Washer M8	
16	1001154378	1	Bracket	
17	1001187587	5	Pin, Snapper w/Lanyard	
18	1001210302	1	Gate	
19	1001210586	1	Plate, Gate Support	
20	1001210963	2	Cover (LH)	
21	1001232257	2	Brace	
22	0700820	AR	Bolt M8 x 60	
23	0701018	2	Bolt M10 x 50	
24	0701019	10	Bolt M10 x 55	
25	3291006	12	Nut M10	
26	4812000	28	Washer M10	
27	1001211895	52	Washer	
28	1001137675	14	Bumper	
200	1001272023	1	Rail Kit (Dual, FD, SCG) (Includes Items 201-214)	
201	1001271892	Ref	Rail (Side Lower Right)	
202	1001271897	Ref	Rail (Side Lower Left)	
203	1001271898	Ref	Rail (Extension Front Lower)	
204	1001271902	Ref	Rail (Extension Side Top)	
205	1001271908	Ref	Rail (Extension Lower Left)	
206	1001271912	Ref	Rail (Extension Lower Right)	
207	1001271913	Ref	Rail (Extension Upper Right)	
208	1001271919	Ref	Rail (Extension Upper Left)	
209	1001271921	Ref	Rail (Rear Upper Right)	
210	1001271925	Ref	Rail (Front Upper Right)	
211	1001271929	Ref	Rail (Rear Upper Left)	
212	1001271933	Ref	Rail (Front Upper Left)	
213	1001271935	Ref	Tube (Rear Top Entry)	
214	1001271937	Ref	Tube (Platform Top Rail)	

SECTION 4 - PLATFORM

FIGURE 4-12. RAILS INSTALLATION - FOLD-DOWN RAILS/GATE ENTRY (OUTSIDE TUBE SLIDER) (KOREA SPECS)

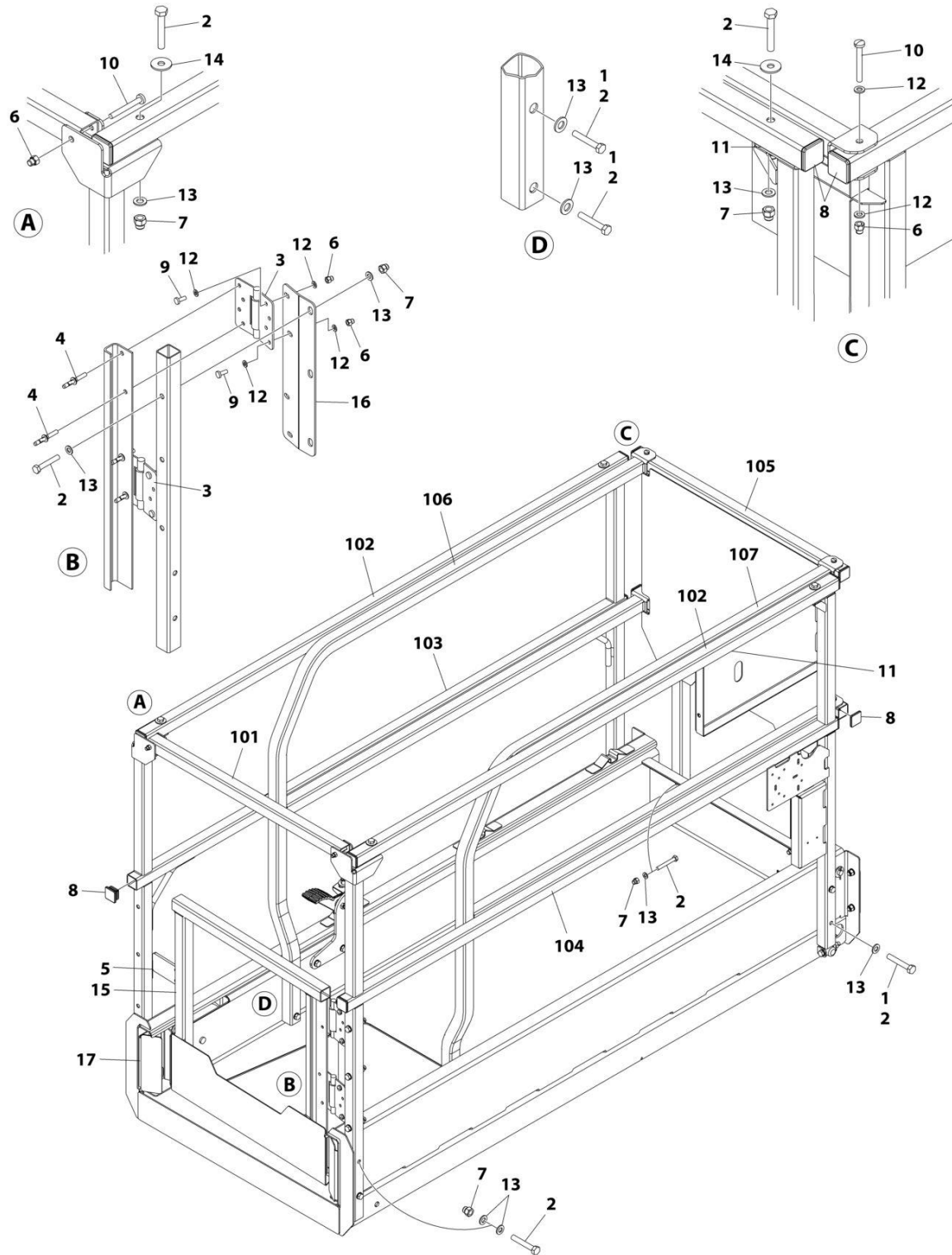

ART_1001286627

SECTION 4 - PLATFORM

**FIGURE 4-12. RAILS INSTALLATION - FOLD-DOWN RAILS/GATE ENTRY (OUTSIDE TUBE SLIDER)
(KOREA SPECS)**

ITEM	PART NUMBER	QTY	DESCRIPTION	REV
	1001286627	Ref	RAILS INSTALLATION	A
1	0100011	AR	Compound, Locking	
2	0700818	23	Bolt M8 x 50	
3	2600281	2	Hinge	
4	2080040	4	Fastener	
5	3080007	1	Magnet	
6	3290606	10	Nut M6	
7	3290806	15	Nut M8	
8	3520072	12	Plug	
9	4010608	4	Screw M6 x 16	
10	4010618	6	Screw M6 x 50	
11	4420062	10 in/ 25cm	Tape	
12	4811700	16	Washer M6	
13	4811900	34	Washer M8	
14	4811902	4	Washer M8	
15	1001210302	1	Gate	
16	1001210586	1	Plate, Gate Support	
17	1001210963	2	Cover (LH)	
100	1001286522	1	Rail Kit (Dual, FD, SCG) (Includes 101-107)	
101	1001206224	1	Tube (Rear Top)	
102	1001223835	2	Tube (Platform Top)	
103	1001286509	1	Rail (Platform Lower Left)	
104	1001286510	1	Rail (Platform Lower Right)	
105	1001286512	1	Rail (Extension End)	
106	1001286514	1	Rail (Extension Left)	
107	1001286517	1	Rail (Extension Right)	

SECTION 4 - PLATFORM

FIGURE 4-13. RAILS INSTALLATION - FOLD-DOWN RAILS/GATE ENTRY (NARROW ACCESS)

ITEM	PART NUMBER	QTY	DESCRIPTION	REV
	1001249082	Ref	RAILS INSTALLATION - FOLD-DOWN RAILS/GATE ENTRY	C
1	0641416	8	Bolt 1/4 x 2	
2	0700818	12	Bolt M8 x 50	
3	0760608	2	Bolt M6 x 16	
4	0760618	2	Bolt M6 x 50	
5	0761019	2	Bolt M10 x 55	
6	1001256675	1	Decal - JLG	
7	2080040	8	Fastener	
8	2080043	8	Rivnut	
9	2600281	4	Hinge	
10	3290501	2	Nut M5	
11	3290605	2	Nut M6	
12	3290606	26	Nut M6	
13	3290806	8	Nut M8	
14	3291006	2	Nut M10	
15	3422219	2	Pin	
16	3520072	16	Plug	
17	3820032	4	Rivet	
18	3860111	2	Roller	
19	4010608	8	Screw M6 x 16	
20	4010618	16	Screw M6 x 50	
21	4071095	AR	Shim	
22	4220309	4	Stop	
23	4420062	1.5 ft /0.46m	Tape	
24	4811700	20	Washer M6	
25	4811900	20	Washer M8	
26	4812000	2	Washer M10	
27	1001187587	4	Pin	
28	1001206226	2	Rod	
29	1001210963	2	Cover (LH)	
30	1001234395	2	Bolt M5 x 50	
31	1001243528	2	Magnet	
32	1001249114	2	Rail (Upper Slide)	
33	1001251383	1	Gate (Right)	
34	1001251388	1	Gate (Left)	
35	1001254825	1	Panel	
36	1001256471	2	Rail (Platform Extension)	
37	1001257890	2	Knob	
38	1001258528	1	Plate	
39	1001258704	2	Bracket	
40	1001261040	1	Decal - Max Capacity	
100	1001258617	1	Rail Narrow Access Kit (Not Shown)	A
101	1001249109	1	Rail (Upper Left)	
102	1001249111	1	Rail (Upper Right)	
103	1001258620	2	Tube (Drop Bar)	
200	1001258618	1	Rail Narrow Access Kit (Not Shown)	B
201	1001210446	1	Rail (Lower Extension)	
202	1001249096	1	Rail (Lower Left)	
203	1001249107	1	Rail (Lower Right)	

SECTION 4 - PLATFORM

ITEM	PART NUMBER	QTY	DESCRIPTION	REV
204	1001249110	1	Rail (Upper Left)	
205	1001249112	1	Rail (Upper Right)	
206	1001258411	1	Rail (Upper Extension)	

SECTION 4 - PLATFORM

FIGURE 4-14. HANDLE EXTENSION INSTALLATION (OPTIONAL)

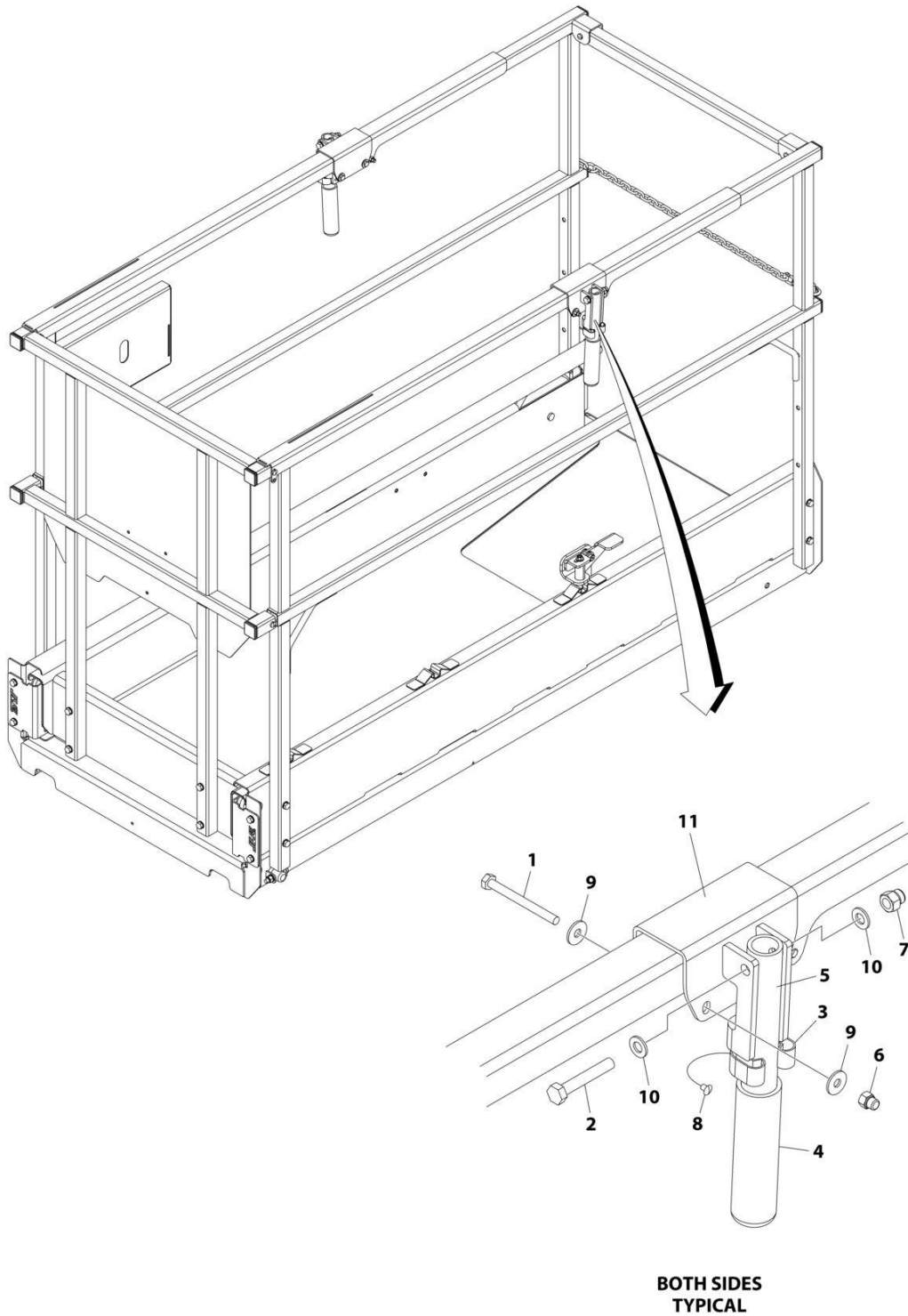

ART_1001222587

SECTION 4 - PLATFORM

FIGURE 4-14. HANDLE EXTENSION INSTALLATION (OPTIONAL)

ITEM	PART NUMBER	QTY	DESCRIPTION	REV
	1001222587	Ref	HANDLE EXTENSION INSTALLATION (OPTIONAL)	B
1	0700621	4	Bolt M6 x 65	
2	0700818	2	Bolt M8 x 50	
3	1380132	2	Clip	
4	2560088	2	Grip, Handle	
5	2560190	2	Handle	
6	3290606	2	Nut M6	
7	3290806	2	Nut M8	
8	3820019	2	Rivet	
9	4811702	8	Washer M6	
10	4811900	4	Washer M8	
11	1001216823	2	Bracket	

SECTION 4 - PLATFORM

FIGURE 4-15. GATE LATCH INSTALLATION - OPTIONAL

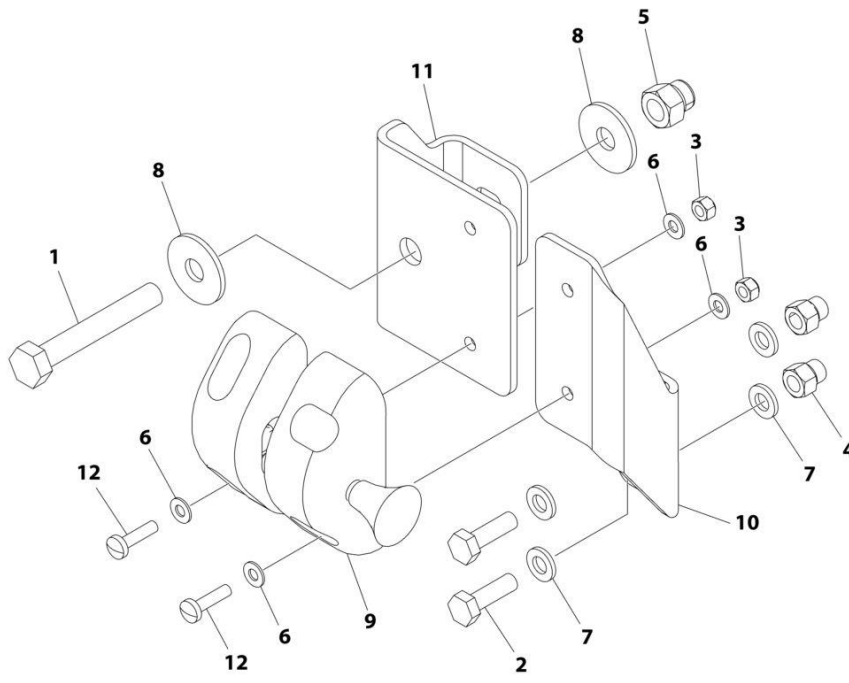

ART_1001220995

SECTION 4 - PLATFORM

FIGURE 4-15. GATE LATCH INSTALLATION - OPTIONAL

ITEM	PART NUMBER	QTY	DESCRIPTION	REV
	1001220995	Ref	GATE LATCH INSTALLATION	B
1	0700819	1	Bolt M8 x 55	
2	0760610	2	Bolt M6 x 20	
3	3290405	4	Nut M4	
4	3290606	2	Nut M6	
5	3290806	1	Nut M8	
6	4811400	8	Washer M4	
7	4811700	4	Washer M6	
8	4811902	2	Washer M8	
9	1001134821	1	Latch	
10	1001220409	1	Mount	
11	1001220410	1	Plate	
12	4010408	4	Screw M4 x 16	

SECTION 4 - PLATFORM

FIGURE 4-16. PLATFORM CONTROL BOX INSTALLATION (MACHINES WITH SN STARTING WITH G2, B2, AND M2)

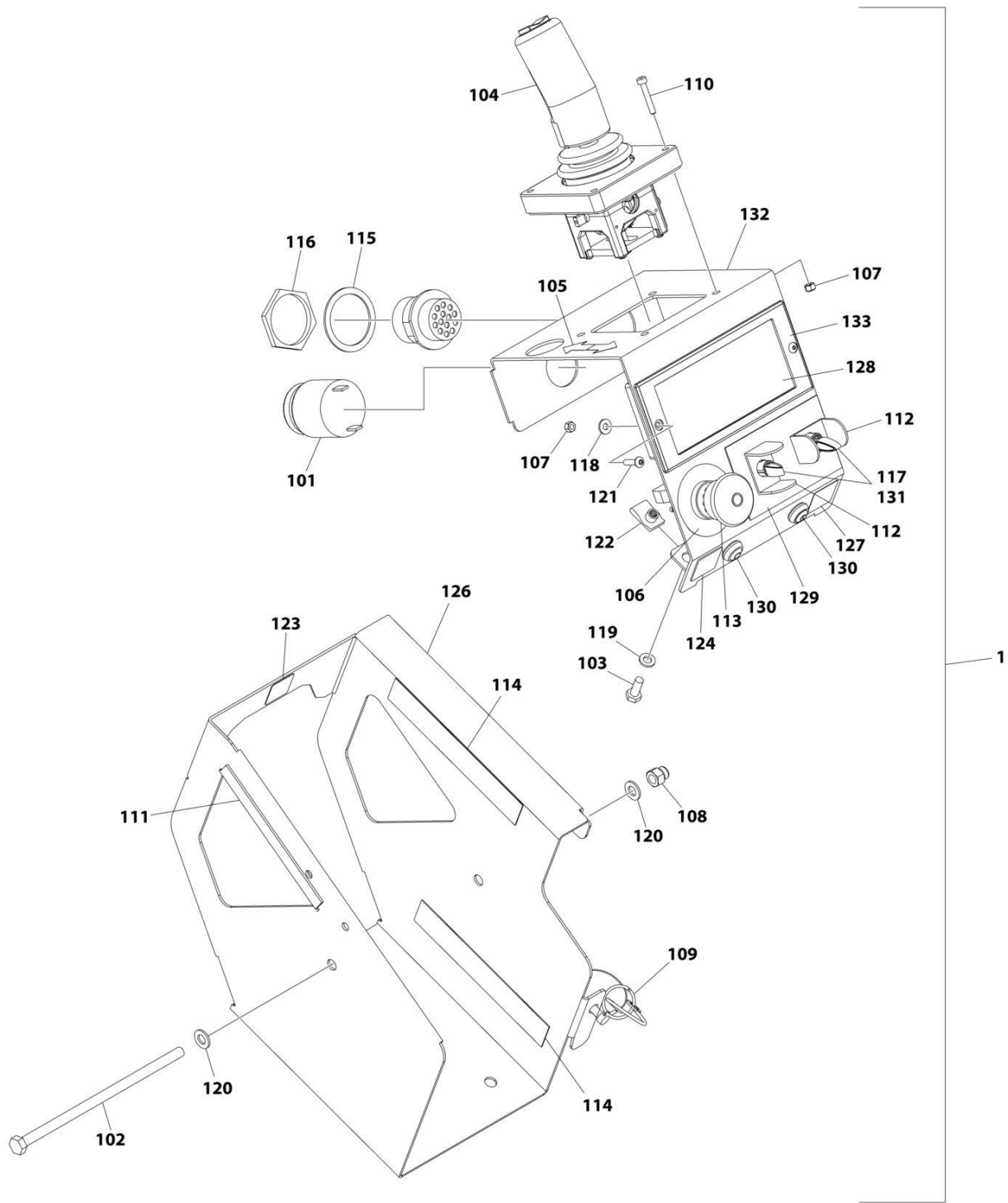

ART_1001274659

SECTION 4 - PLATFORM

FIGURE 4-16. PLATFORM CONTROL BOX INSTALLATION (MACHINES WITH SN STARTING WITH G2, B2, AND M2)

ITEM	PART NUMBER	QTY	DESCRIPTION	REV
	1001274659	Ref	PLATFORM CONTROL INSTALLATION (LED)	A
1	1001274604	1	Platform Control Box	B
101	0140030	1	Alarm	
102	0700835	1	Bolt M8 x 180	
103	0760610	2	Bolt M6 x 20	
104	1600402	1	Controller Assembly (See Separate Breakdown in this Section)	
105	1703819	1	Decal - Arrow	
106	1704260	1	Decal - Emergency Stop	
107	3290405	6	Nut M4	
108	3290806	1	Nut M8	
109	3423278	1	Pin, Snap with Lanyard	
110	4031509	4	Capscrew M4 x 25	
111	4060803	6 in/ 14cm	Flex-Trim	
112	4060906	2	Guard, Switch	
113	4360475	1	Switch, Emergency Stop	
113	7020175	1	Cap	
113	7020176	1	Block, Contact	
114	4420062	12 in/ 30cm	Tape	
115	4460496	1	Washer, Terminal	
116	4460497	1	Nut, Terminal	
117	4711700	2	Washer 7/16	
118	4811400	2	Washer M4	
119	4811700	2	Washer M6	
120	4811900	2	Washer M8	
121	1001047064	2	Screw M4 x 15	
122	1001130220	2	Nut, Tinnerman M6	
123	1001132358	1	Decal - Steer	
124	1001132361	1	Decal - Horn	
125	1001200819	1	Platform Control Box Harness (Not Shown) (See Separate Breakdown in ELECTRICAL Section)	
126	1001209596	1	Plate, Box (Outside)	
127	1001213886	1	Decal - Indoor/Outdoor	
128	1001218285	1	Decal - Platform Control	
129	1001220893	1	Decal - Lift/Drive Function	
130	1001226749	2	Switch, Push Button	
131	1001258446	2	Switch, Toggle	
132	1001262655	1	Plate, Box (Inside)	
133	1001274605	1	Module, Platform Control	

SECTION 4 - PLATFORM

FIGURE 4-17. PLATFORM CONTROL BOX INSTALLATION (MACHINES WITH SN STARTING WITH G2) (CHINA & ANSI EXPORT SPEC)

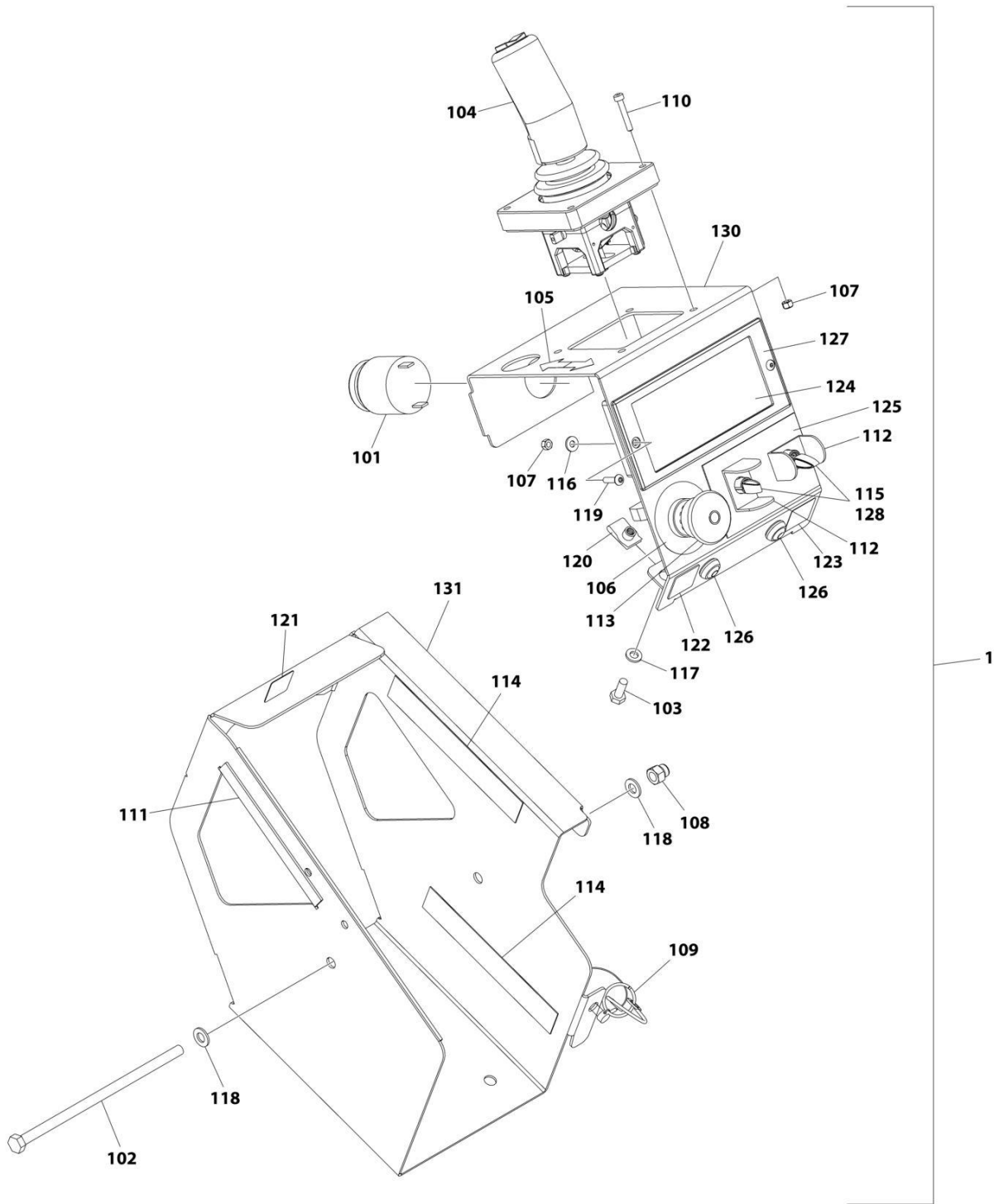

ART_1001274660

SECTION 4 - PLATFORM

FIGURE 4-17. PLATFORM CONTROL BOX INSTALLATION (MACHINES WITH SN STARTING WITH G2) (CHINA & ANSI EXPORT SPEC)

ITEM	PART NUMBER	QTY	DESCRIPTION	REV
	1001274660	Ref	PLATFORM CONTROL INSTALLATION	A
1	1001274613	1	Platform Control Box	C
101	0140030	1	Alarm	
102	0700835	1	Bolt M8 x 180	
103	0760610	2	Bolt M6 x 20	
104	1600402	1	Controller Assembly (See Separate Breakdown in this Section)	
105	1703819	1	Decal - Arrow	
106	1704260	1	Decal - Emergency Stop	
107	3290405	6	Nut M4	
108	3290806	1	Nut M8	
109	3423278	1	Pin, Snap with Lanyard	
110	4031509	4	Capscrew M4 x 25	
111	4060803	6 in /14 cm	Flex-Trim	
112	4060906	2	Guard, Switch	
113	1001274559	1	Switch, Emergency Stop (Plastic)	
114	4420062	12 in /30 cm	Tape	
115	4711700	2	Washer 7/16	
116	4811400	2	Washer M4	
117	4811700	2	Washer M6	
118	4811900	2	Washer M8	
119	1001047064	2	Screw M4 x 15	
120	1001130220	2	Nut, Tinnerman M6	
121	1001132358	1	Decal - Steer	
122	1001132361	1	Decal - Horn	
123	1001213886	1	Decal - Indoor/Outdoor	
124	1001218285	1	Decal - Platform Control	
125	1001220893	1	Decal - Lift/Drive Function	
126	1001226749	2	Switch, Push Button	
127	1001228112	1	Module, Platform Control	
128	1001258446	2	Switch, Toggle	
129	1001291630	1	Platform Control Box Harness (Not Shown) (See Separate Breakdown in ELECTRICAL Section)	
130	1001270470	1	Plate, Box (Inside)	
131	1001270471	1	Plate, Box (Outside)	

SECTION 4 - PLATFORM

FIGURE 4-18. PLATFORM CONTROL BOX INSTALLATION (MACHINES WITH SN STARTING WITH G2) (ANSI EXPORT SPEC ONLY)

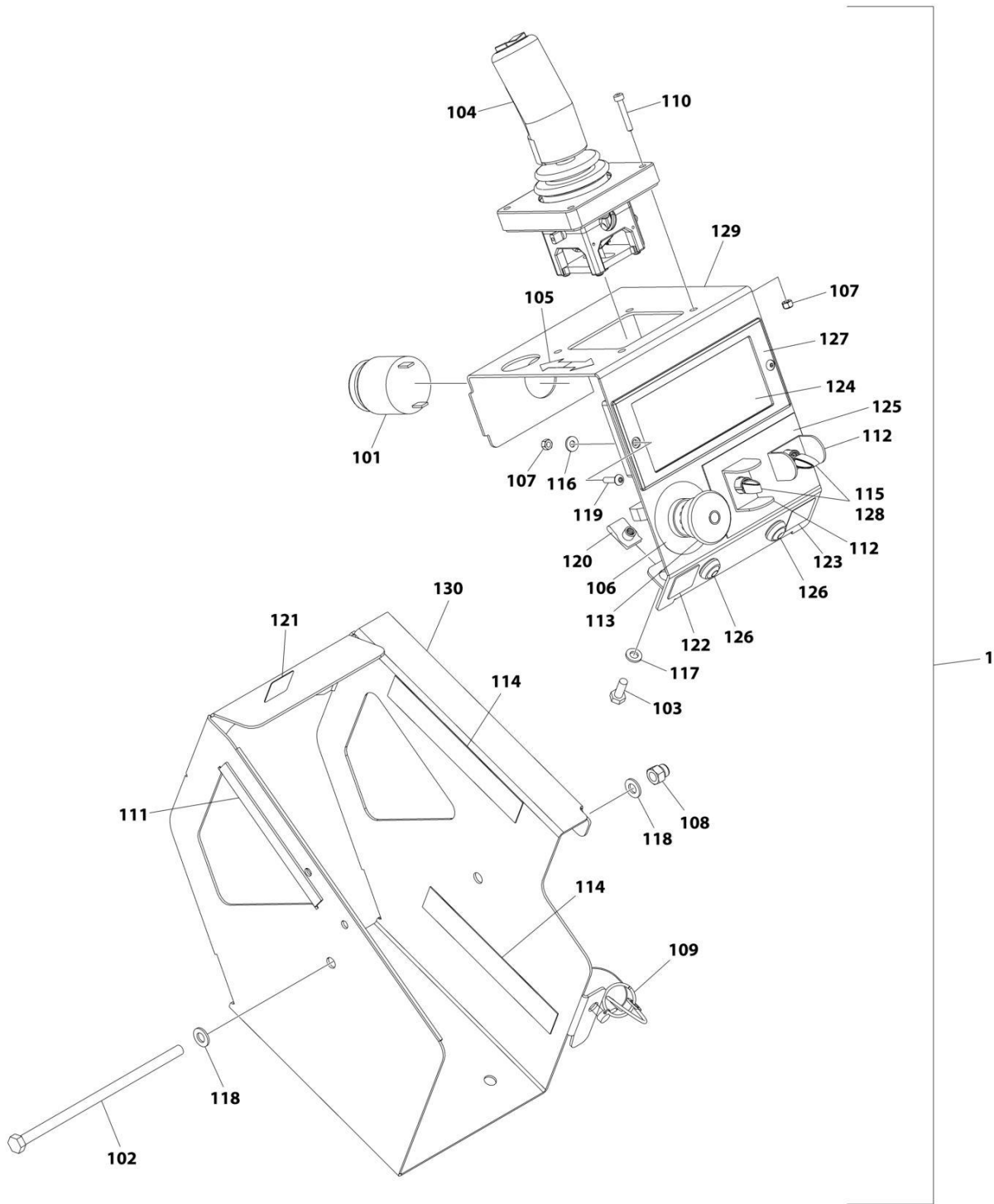

ART_1001286159

SECTION 4 - PLATFORM

FIGURE 4-18. PLATFORM CONTROL BOX INSTALLATION (MACHINES WITH SN STARTING WITH G2) (ANSI EXPORT SPEC ONLY)

ITEM	PART NUMBER	QTY	DESCRIPTION	REV
	1001286159	Ref	PLATFORM CONTROL INSTALLATION	A
	1001286165	1	Platform Control Box	B
101	0140030	1	Alarm	
102	0700835	1	Bolt M8 x 180	
103	0760610	2	Bolt M6 x 20	
104	1600402	1	Controller Assembly (See Separate Breakdown in this Section)	
105	1703819	1	Decal - Arrow	
106	1704260	1	Decal - Emergency Stop	
107	3290405	6	Nut M4	
108	3290806	1	Nut M8	
109	3423278	1	Pin, Snap with Lanyard	
110	4031509	4	Capscrew M4 x 25	
111	4060803	6 in /14cm	Flex-Trim	
112	4060906	2	Guard, Switch	
113	4360475	1	Switch, Emergency Stop (Metal)	
113	7020175	1	Cap	
113	7020176	1	Block, Contact	
113	1001274559	1	Switch, Emergency Stop (Plastic)	
114	4420062	12 in /30cm	Tape	
115	4711700	2	Washer 7/16	
116	4811400	2	Washer M4	
117	4811700	2	Washer M6	
118	4811900	2	Washer M8	
119	1001047064	2	Screw M4 x 15	
120	1001130220	2	Nut, Tinnerman M6	
121	1001132358	1	Decal - Steer	
122	1001132361	1	Decal - Horn	
123	1001213886	1	Decal - Indoor/Outdoor	
124	1001218285	1	Decal - Platform Control	
125	1001220893	1	Decal - Lift/Drive Function	
126	1001226749	2	Switch, Push Button	
127	1001228112	1	Module, Platform Control	
127	1001274605	1	Module, Platform Control	
128	1001258446	2	Switch, Toggle	
129	1001270470	1	Plate, Box (Inside)	
130	1001270471	1	Plate, Box (Outside)	
131	1001269999	1	Platform Control Box Harness (Not Shown) (See Separate Breakdown in ELECTRICAL Section)	

SECTION 4 - PLATFORM

FIGURE 4-19. PLATFORM CONTROL PLUG INSTALLATION

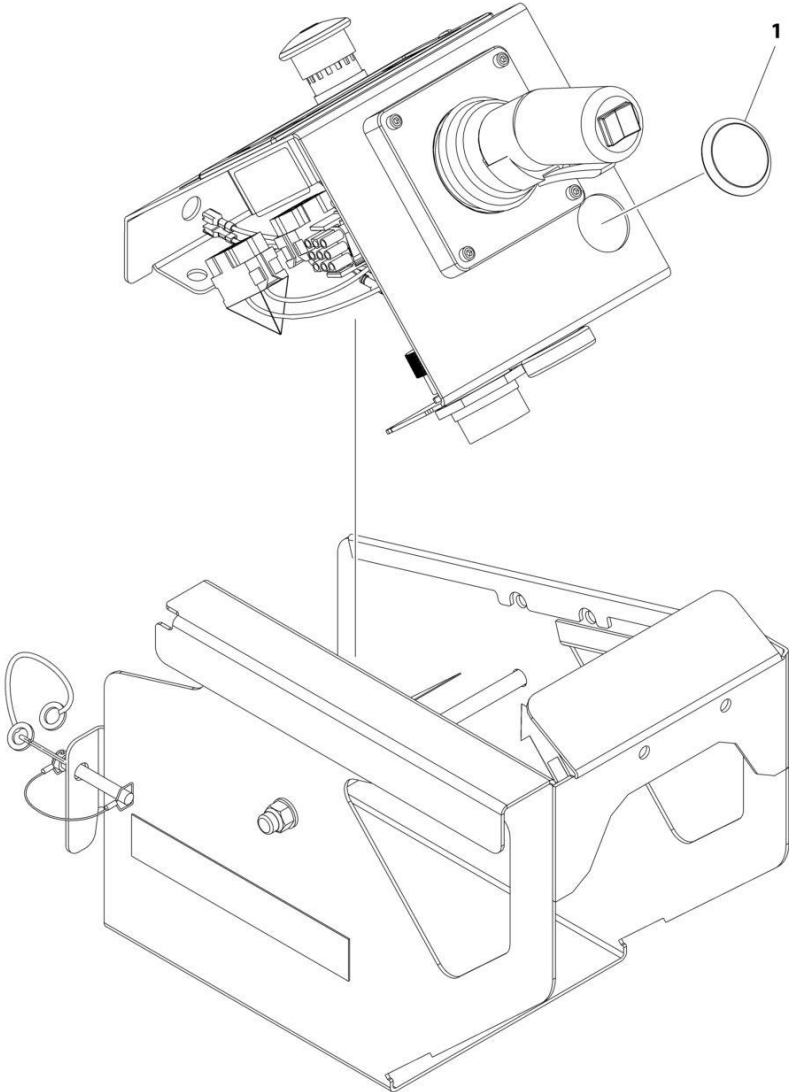

ART_1001274661

SECTION 4 - PLATFORM

FIGURE 4-19. PLATFORM CONTROL PLUG INSTALLATION

ITEM	PART NUMBER	QTY	DESCRIPTION	REV
1	1001274661 1001262221	Ref 1	PLATFORM CONTROL PLUG INSTALLATION Plug	A

SECTION 4 - PLATFORM

FIGURE 4-20. DRIVE/STEER CONTROLLER ASSEMBLY

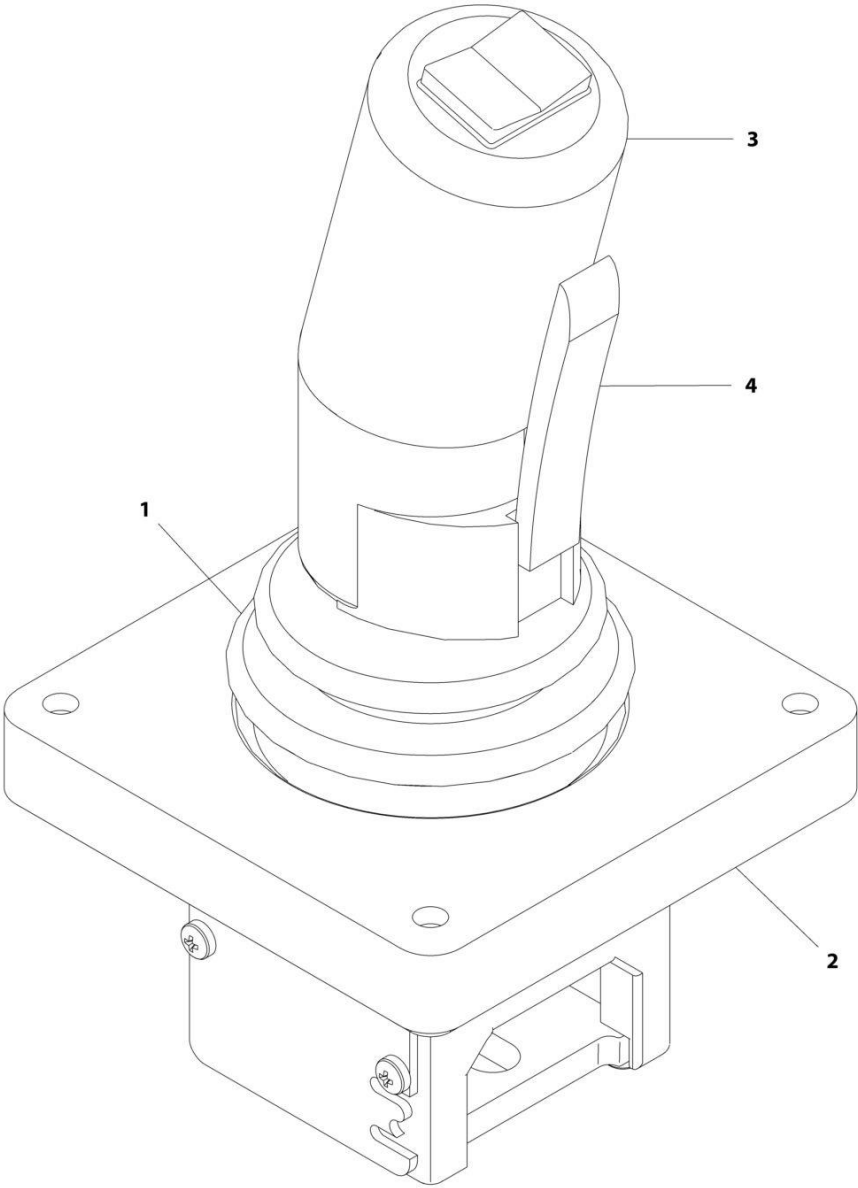

ART_1600402

SECTION 4 - PLATFORM

FIGURE 4-20. DRIVE/STEER CONTROLLER ASSEMBLY

ITEM	PART NUMBER	QTY	DESCRIPTION	REV
	1600402	Ref	DRIVE/STEER CONTROLLER ASSEMBLY	A
1	70001250	1	Boot, Panel	
2	70001252	1	Gasket, Mounting	
2	70001251	1	Bezel, Mounting	
3	70003650	1	Handle Repair Kit (Includes handle gasket, item#4 push button and item #4 lever installed in front handle half, back handle half, top actuator, boot and hardware.)	
3	70000084	1	Cap, Rubber	
3	70000082	1	Microswitch	
3	7027766	1	Ring, Retaining	
3	7027365	1	Actuator, Handle	
3	70001253	1	Gasket, Handle	
3	70000683	4	Washer, Neoprene	
3	70000685	2	Spacer, Plastic	
3	70000686	2	Screw (Top)	
3	70000684	2	Screw (Bottom)	
4	7027367	1	Switch, Push Button	
4	7027765	1	Lever, Enable	

SECTION 4 - PLATFORM

FIGURE 4-21. USB/PHONE CRADLE INSTALLATION

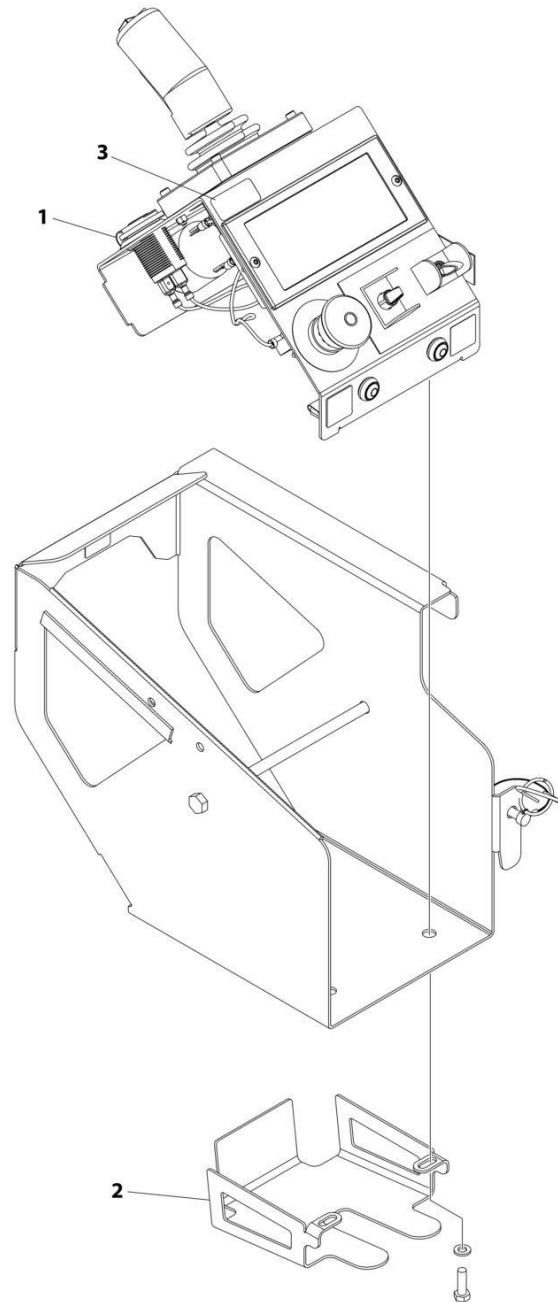

ART_1001262150

SECTION 4 - PLATFORM

FIGURE 4-21. USB/PHONE CRADLE INSTALLATION

ITEM	PART NUMBER	QTY	DESCRIPTION	REV
	1001262150	Ref	USB/PHONE CRADLE INSTALLATION	B
1	1001253800	1	Terminal, USB Receptacle	
2	1001261131	1	Bracket, Phone	
3	1001274168	1	Decal, USB Charge	

SECTION 4 - PLATFORM

FIGURE 4-22. OVERHEAD PROTECTION INSTALLATION (KOREAN SPECS)

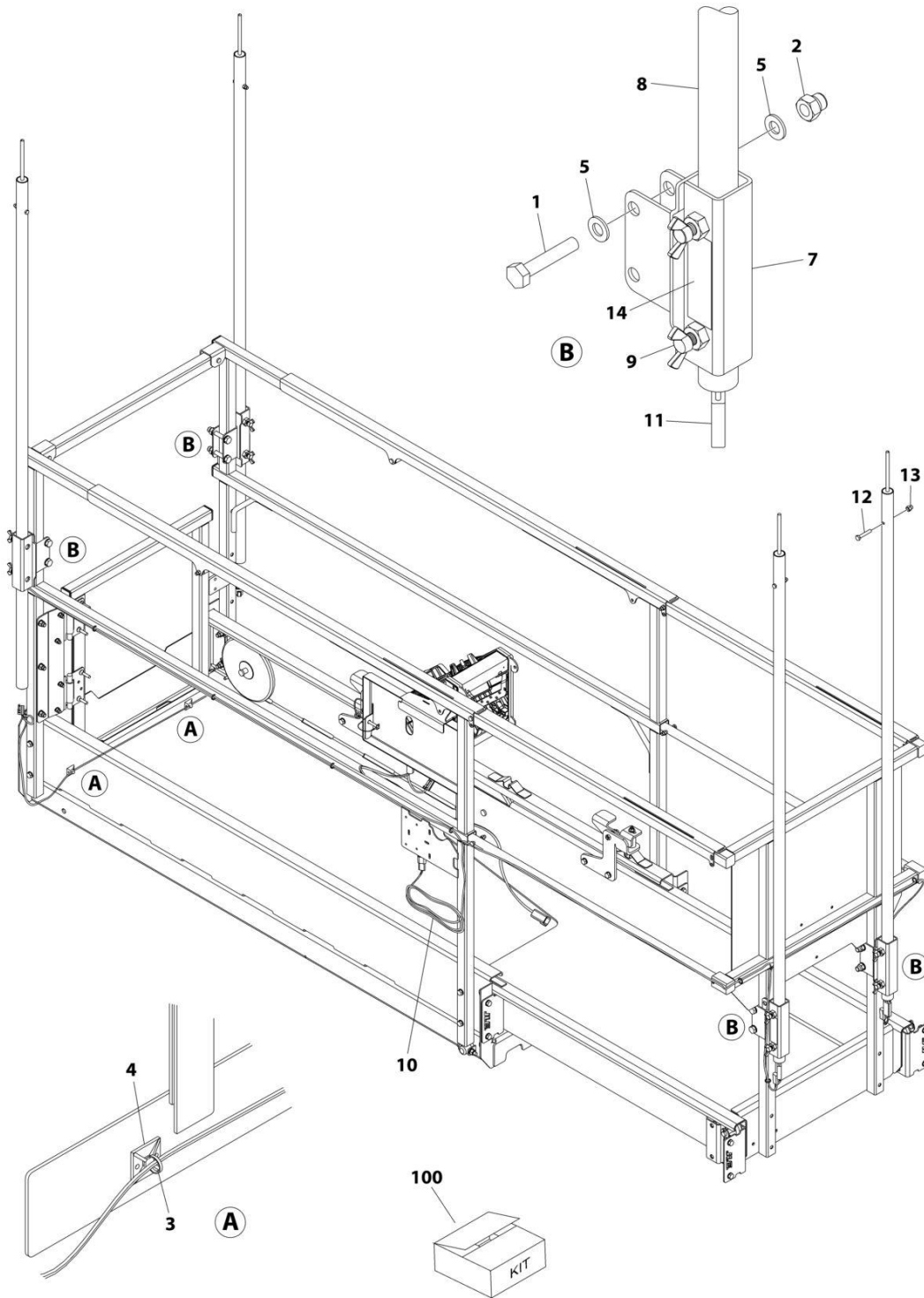

ART_1001220216

SECTION 4 - PLATFORM

FIGURE 4-22. OVERHEAD PROTECTION INSTALLATION (KOREAN SPECS)

ITEM	PART NUMBER	QTY	DESCRIPTION	REV
	1001220216	Ref	OVERHEAD PROTECTION INSTALLATION (KOREAN SPECS)	B
1	0701019	8	Bolt M10 x 55	
2	3291006	8	Nut M10	
3	4240017	AR	Tie-Strap	
4	4460234	2	Mount, Tie-Strap	
5	4812000	16	Washer M10	
7	1001221275	4	Bracket	
8	1001221276	4	Tube	
9	1001222914	8	Thumb Screw	
10	1001224468	1	Overhead Protection Harness	
10	4460891	4	Plug, Male - 2 Position (SW03-SW06)	
10	4460465	8	Socket, Female	
10	4460536	1	Receptacle, Female - 3 Position (X567)	
10	4460464	2	Pin, Male	
10	4460466	1	Plug, Terminal	
11	1001226277	4	Switch, Overhead Protection	
12	0700616	4	Bolt M6 x 40	
13	3290606	4	Nut M6	
14	1001228184	1	Decal - Overhead Protection Weight	
100	1001221244	1	Overhead Protection Kit (Includes Items 1, 2, 5-9 & 11-14)	

SECTION 4 - PLATFORM

FIGURE 4-23. PANEL CARRIER INSTALLATION (R1932)

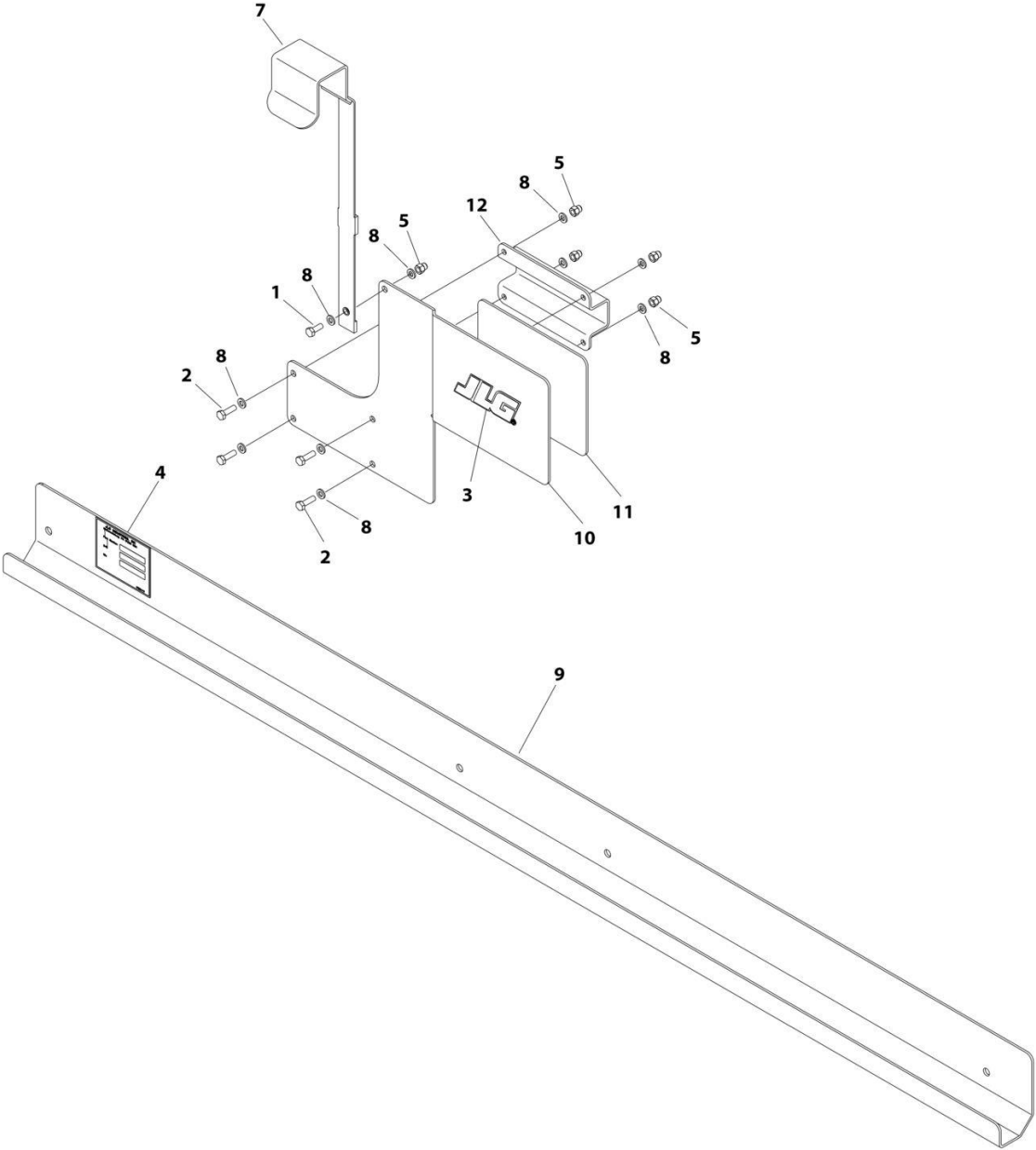

ART_1001235924

SECTION 4 - PLATFORM

FIGURE 4-23. PANEL CARRIER INSTALLATION (R1932)

ITEM	PART NUMBER	QTY	DESCRIPTION	REV
	1001235924	Ref	PANEL CARRIER INSTALLATION	B
1	0760608	1	Bolt M6 x 16	
2	0760610	4	Bolt M6 x 20	
3	1702010	1	Decal - JLG	
4	See Note	NSS	Nameplate - Accessory SN (Note: Not Available for Purchase)	
5	3290606	5	Nut M6	
6	3574505	1	Plate	
7	4240165	1	Strap	
8	4811700	10	Washer M6	
9	1001235536	1	Channel	
10	1001235863	1	Plate	
11	1001236507	1	Decal – Panel Carrier Capacity	
12	4420037	6 in /15cm	Tape	

SECTION 4 - PLATFORM

FIGURE 4-24. PIPE RACK INSTALLATION (R1932)

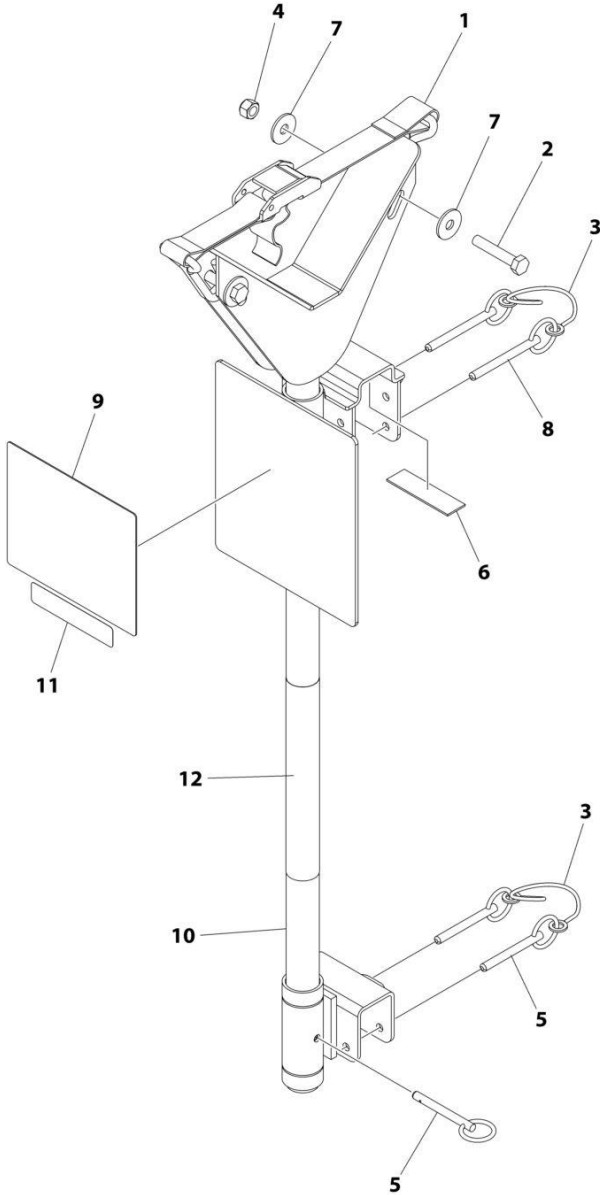

ART_1001270855

SECTION 4 - PLATFORM

FIGURE 4-24. PIPE RACK INSTALLATION (R1932)

ITEM	PART NUMBER	QTY	DESCRIPTION	REV
	1001270855	Ref	PIPE RACK INSTALLATION	C
1	0480100	2	Tie-Strap	
2	0700817	4	Bolt M8 x 45	
3	1060379	4	Lanyard	
4	3290805	4	Nut M8	
5	3422661	6	Pin	
6	4420062	AR	Tape	
7	4811902	8	Washer M8	
8	1001235941	4	Pin	
9	1001287711	2	Decal - Pipe Rack Capacity	
10	1001270533	2	Rack Pipe	
11	1001270631	2	Decal - ACCY Weight	
12	1001271412	2	Decal - JLG	

SECTION 4 - PLATFORM

FIGURE 4-25. ELECTRICIANS TREE ACCESSORY

ITEM	PART NUMBER	QTY	DESCRIPTION	REV
	1001273907	Ref	ELECTRICIANS TREE ACCESSORY	A
1	80325	4	Hairpin, Cotter	
2	0440223	2	Bearing, Oilite Flange	
3	0700610	2	Bolt M6 x 20	
4	1060379	4	Lanyard	
5	3290606	2	Nut M6	
6	3421453	3	Pin	
7	3422219	1	Pin	
8	3520072	6	Plug	
9	3760170	8	Ring, Split	
10	3841675	2	Rod	
11	4191706	1	Bolt M6 x 12	
12	4220227	2	Stop, Spool Rod	
13	4240003	1	Strap	
14	4340947	1	Mount, Spool Rack	
15	4711400	2	Washer 1/4	
16	1001189762	3 ft	Tape	
17	1001252626	1	Decal - Accessory Weight	
18	1001273909	1	Support, Base Pivot	
19	1001274838	1	Decal - Electrical Tree Capacity	

SECTION 4 - PLATFORM

FIGURE 4-26. WORKSTATION ACCESSORY

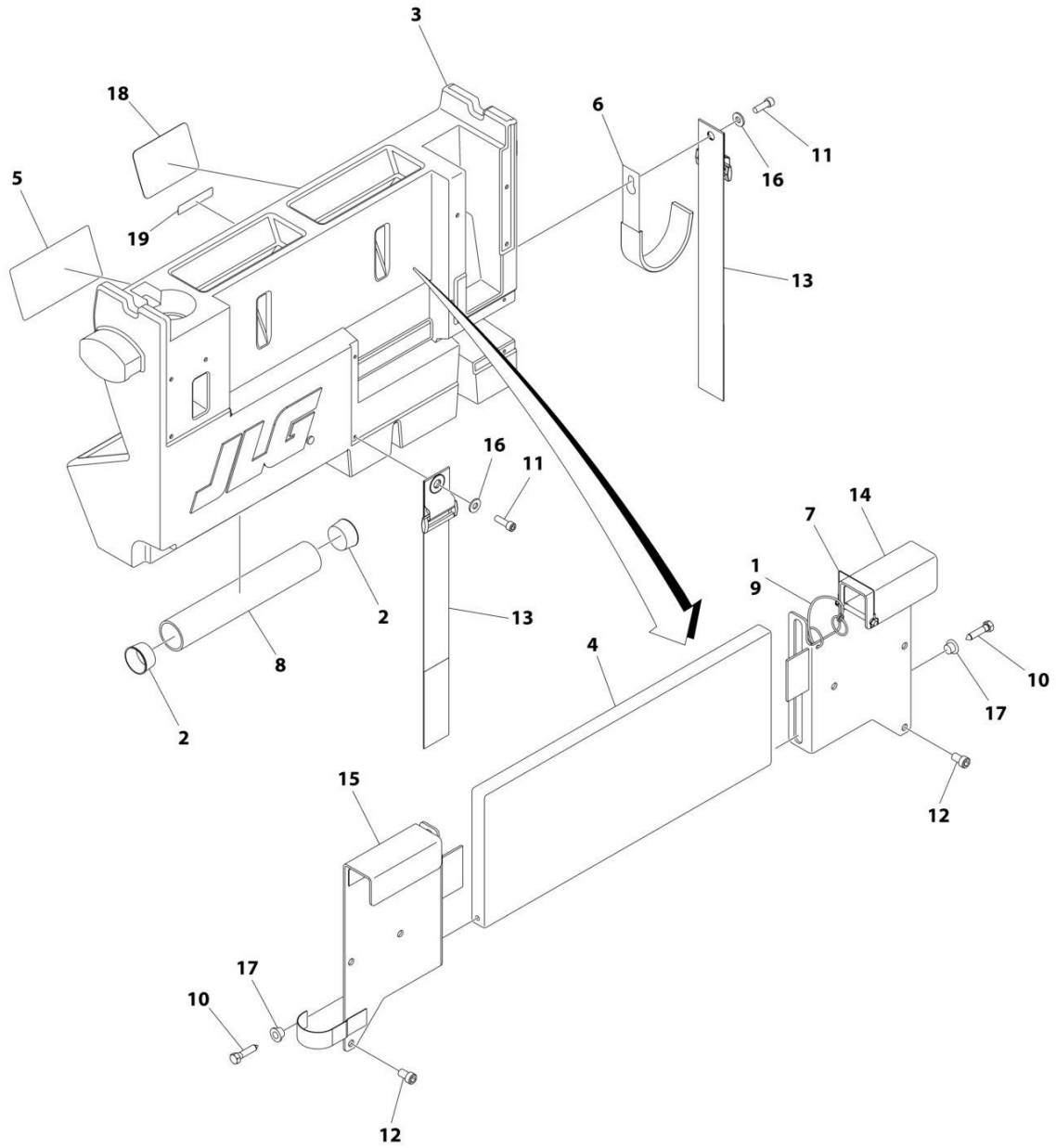

ART_1001273957

SECTION 4 - PLATFORM

FIGURE 4-26. WORKSTATION ACCESSORY

ITEM	PART NUMBER	QTY	DESCRIPTION	REV
	1001273957	Ref	WORKSTATION ACCESSORY	A
1	1060379	1	Lanyard	
2	1120555	2	Cap	
3	1580023	1	Container, Work Bench	
4	1580024	1	Tray, Work Surface	
5	1705997	1	Decal - Workstation	
6	2700100	1	Hook	
7	3422219	1	Pin	
8	3460334	1	Pipe	
9	3760170	2	Ring	
10	3900355	2	Bolt 5/16	
11	3931412	2	Bolt 1/4 x 3/4	
12	3931508	6	Bolt 5/16 x 1/2	
13	4240003	2	Strap	
14	4340853	1	Mount, RH Channel	
15	4340854	1	Mount, LH Channel	
16	4711400	2	Washer 1/4	
17	4740480	2	Washer	
18	1001274837	1	Decal - Workstation Capacity	
19	1001275631	1	Decal - Accessory Weight	

SECTION 4 - PLATFORM

FIGURE 4-27. WORKSTATION INSTALLATION

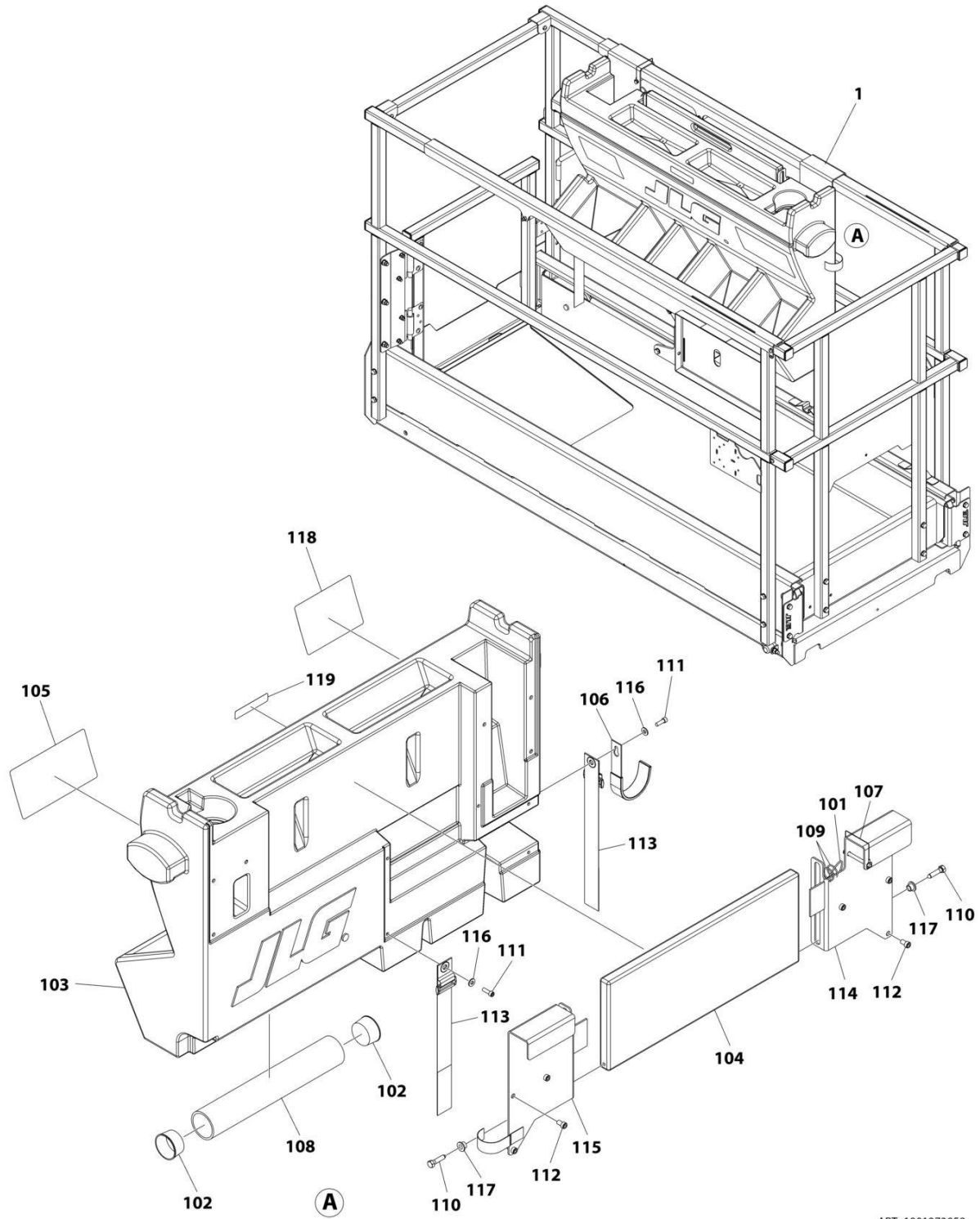

ART_1001273958

SECTION 4 - PLATFORM

FIGURE 4-27. WORKSTATION INSTALLATION

ITEM	PART NUMBER	QTY	DESCRIPTION	REV
	1001273958	Ref	WORKSTATION INSTALLATION	B
1	1001273957	1	Workstation Accessory	B
101	1060379	1	Lanyard	
102	1120555	2	Cap	
103	1580023	1	Container, Work Bench	
104	1580024	1	Tray, Work Surface	
105	1705997	1	Decal - Workstation	
106	2700100	1	Hook, Hanger	
107	3422219	1	Pin	
108	3460334	1	Pipe	
109	3760170	2	Ring	
110	3900355	2	Screw	
111	3931412	2	Bolt 1/4 x 3/4	
112	3931508	6	Bolt 5/16 x 1/2	
113	4240003	2	Strap	
114	4340853	1	Mount, Channel (RH)	
115	4340854	1	Mount, Channel (LH)	
116	4711400	2	Washer 1/4	
117	4740480	2	Washer, Plastic Insert	
118	1001274837	1	Decal - Workstation Capacity	
119	1001275631	1	Decal - ACCY Weight	

SECTION 4 - PLATFORM

FIGURE 4-28. ELECTRICIAN TREE INSTALLATION

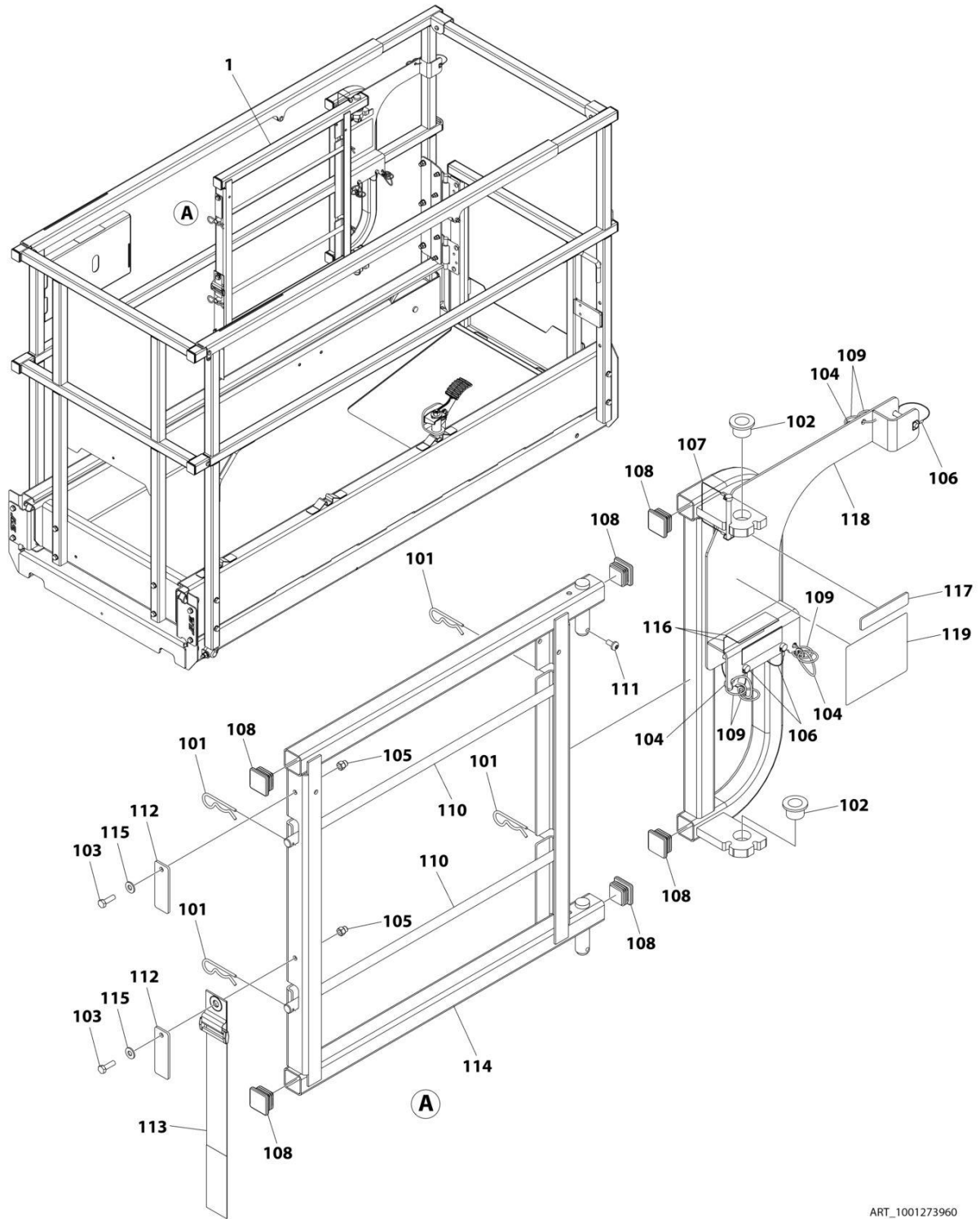

ART_1001273960

SECTION 4 - PLATFORM

FIGURE 4-28. ELECTRICIAN TREE INSTALLATION

ITEM	PART NUMBER	QTY	DESCRIPTION	REV
	1001273960	Ref	ELECTRICIAN TREE INSTALLATION	A
1	1001273907	1	Electrician Tree Accessory	A
101	80325	4	Hairpin, Cotter	
102	0440223	2	Bushing	
103	0700610	2	Bolt M6 x 20	
104	1060379	4	Lanyard	
105	3290606	2	Cap, Nut M6 x 1	
106	3421453	3	Pin	
107	3422219	1	Pin	
108	3520072	6	Plug, Cap	
109	3760170	8	Ring	
110	3841675	2	Rod	
111	4191706	1	Screw M6 x 12	
112	4220227	2	Stop, Spool Rod	
113	4240003	1	Strap	
114	4340947	1	Mount, Spool Rack	
115	4711400	2	Washer 1/4	
116	1001189762	3	Tape	
117	1001252626	1	Decal - ACCY Weight	
118	1001273909	1	Support	
119	1001274838	1	Decal	

SECTION 4 - PLATFORM

FIGURE 4-29. WORKLIGHT INSTALLATION

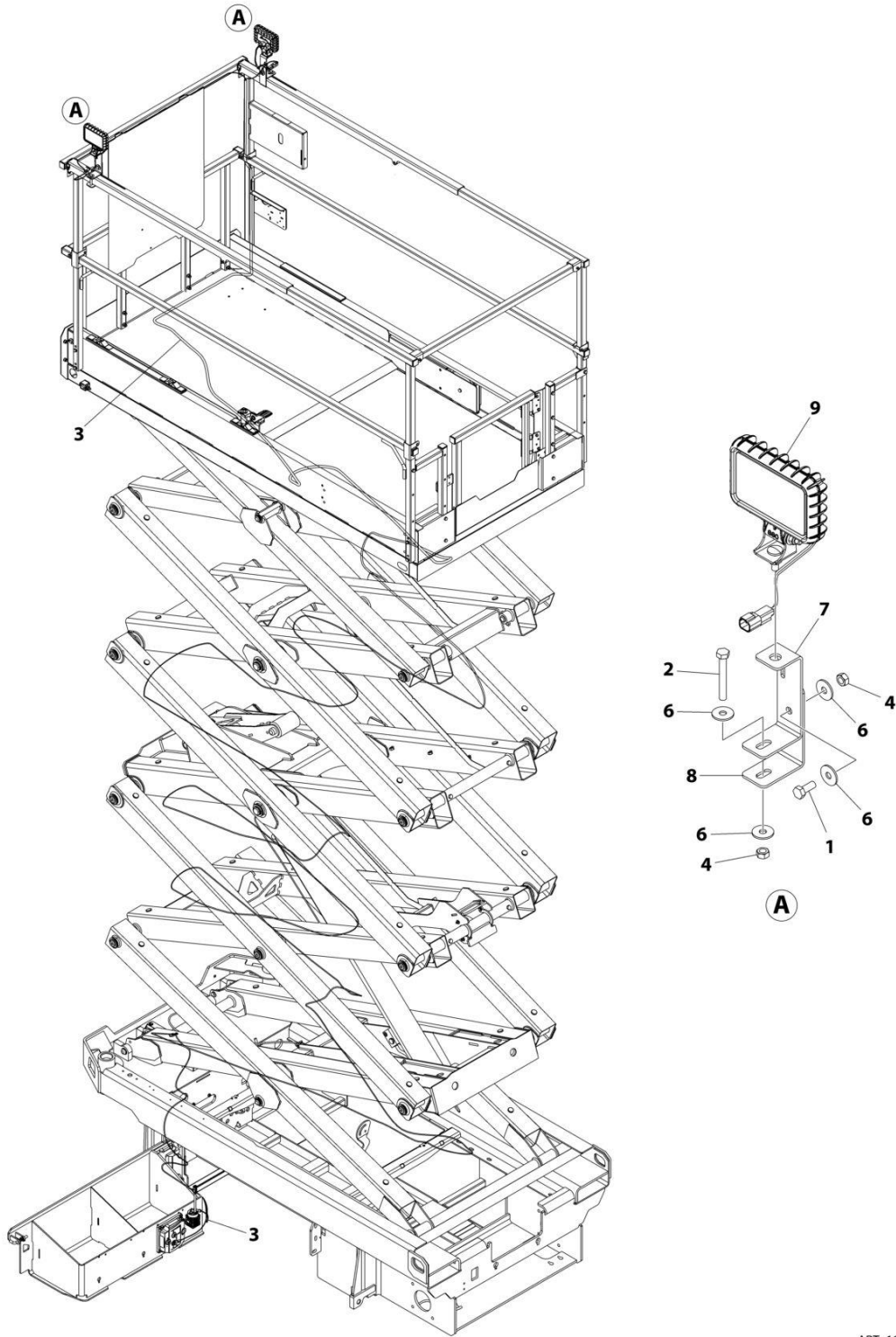

ART_1001273965

SECTION 4 - PLATFORM

FIGURE 4-29. WORKLIGHT INSTALLATION

ITEM	PART NUMBER	QTY	DESCRIPTION	REV
	1001273965	Ref	WORKLIGHT INSTALLATION	A
1	0760810	2	Bolt M8 x 20	
2	0760820	2	Bolt M8 x 60	
3	1061041	1	Cable, Worklight (See Separate Breakdown in ELECTRICAL Section)	
4	3290801	4	Nut M8	
5	4240033	AR	Tie-Strap (Not Shown)	
6	4811902	8	Washer M8	
7	1001273961	2	Bracket	
8	1001273962	2	Bracket	
9	1001273964	2	Lamp, Worklight Kit	
9	1001232586	1	Lamp, Worklight LED with Switch	
9	1001274026	1	Harness, Light (See Separate Breakdown in ELECTRICAL Section)	

SECTION 4 - PLATFORM

FIGURE 4-30. FIRE EXTINGUISHER INSTALLATION

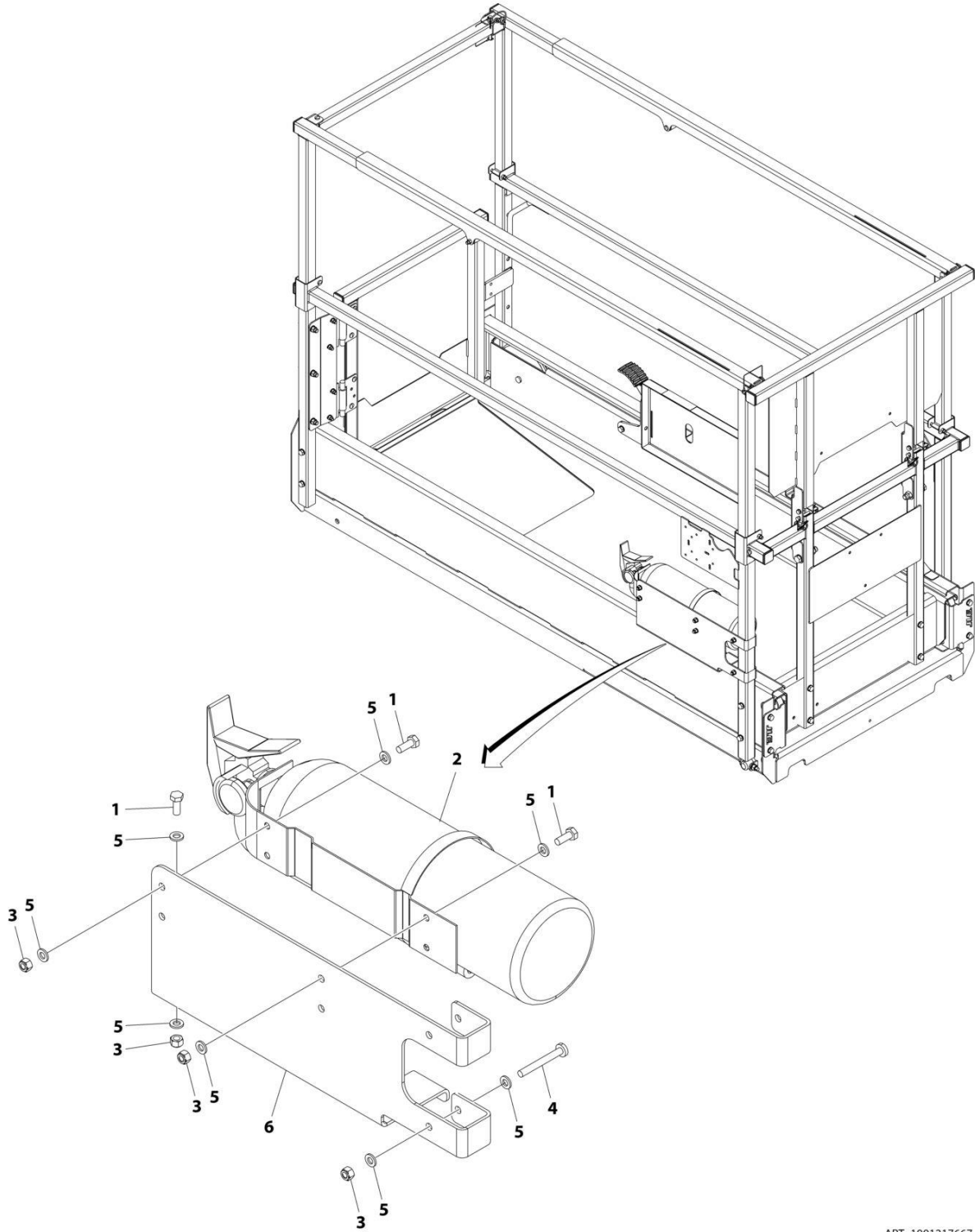

ART_1001217667

SECTION 4 - PLATFORM

FIGURE 4-30. FIRE EXTINGUISHER INSTALLATION

ITEM	PART NUMBER	QTY	DESCRIPTION	REV
	1001217667	Ref	FIRE EXTINGUISHER INSTALLATION	C
1	0760608	5	Bolt M6 x 16	
2	2030011	1	Fire Extinguisher	
3	3290605	7	Nut M6	
4	4010618	2	Screw M6 x 50	
5	4811700	14	Washer M6	
6	1001218509	1	Bracket	

SECTION 5 - CYLINDER

SECTION 5 - CYLINDER

FIGURE 5-1. LIFT CYLINDER ASSEMBLY (MACHINES WITH SN STARTING WITH B2 & M2)

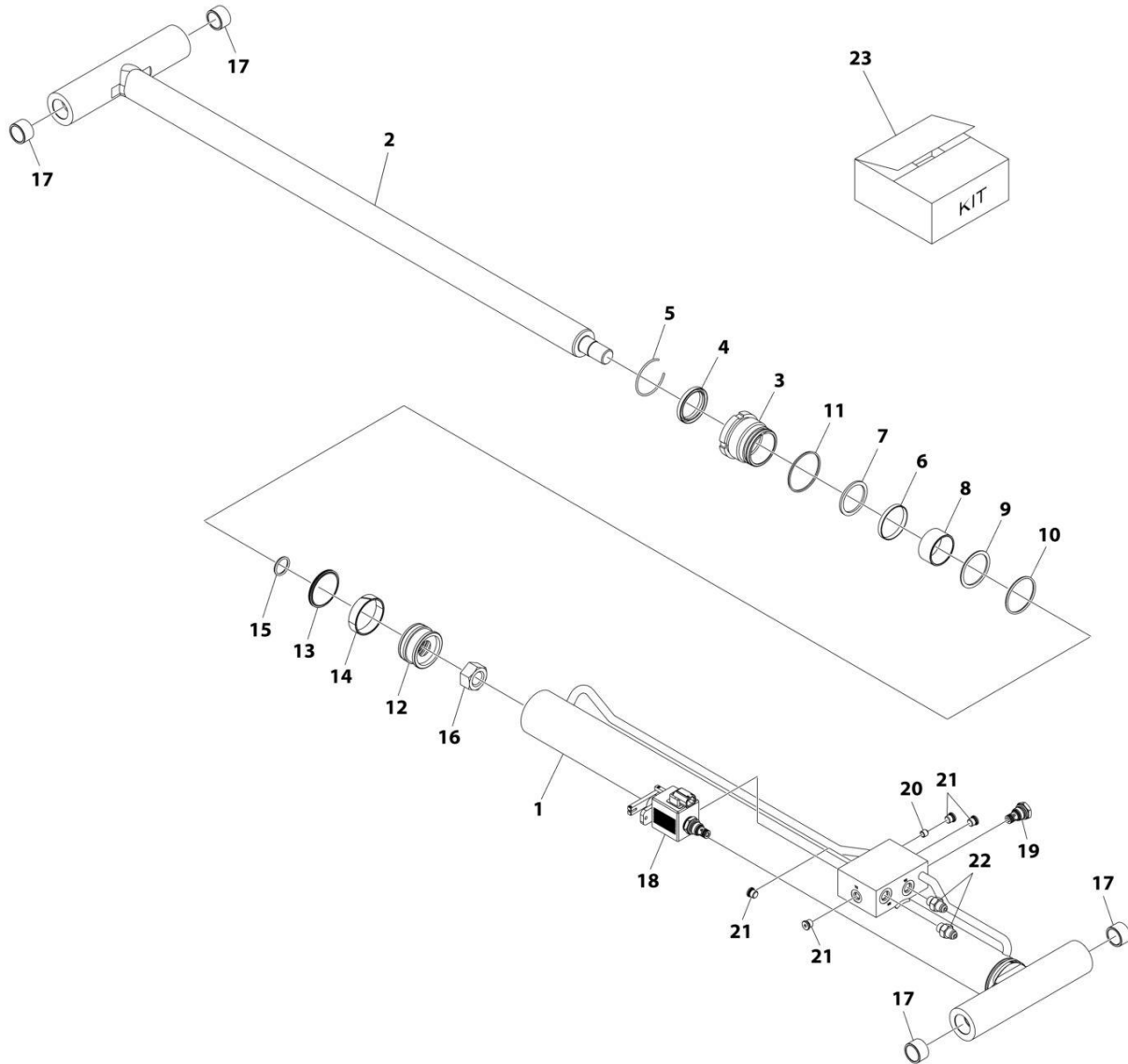

ART_1001198935

SECTION 5 - CYLINDER

FIGURE 5-1. LIFT CYLINDER ASSEMBLY (MACHINES WITH SN STARTING WITH B2 & M2)

ITEM	PART NUMBER	QTY	DESCRIPTION	REV
	1001198935	Ref	LIFT CYLINDER ASSEMBLY	C
		Ref	Note: Original Cylinder May Have Been Replaced with Service Replacement. Identify PN Stamped on Cylinder Before Ordering Parts.	
1	70005790	1	Barrel	
2	70005791	1	Rod	
3	70005792	1	Head	
4	See Note	NSS	Wiper (Note: Use Item 23)	
5	70002410	1	Ring, Retaining	
6	See Note	NSS	Seal, Rod (Note: Use Item 23)	
7	See Note	NSS	Ring, Back-up (Note: Use Item 23)	
8	70005793	1	Spacer	
9	See Note	NSS	O-Ring (Note: Use Item 23)	
10	See Note	NSS	Ring, Back-up (Note: Use Item 23)	
11	See Note	NSS	O-Ring (Note: Use Item 23)	
12	70005794	1	Piston	
13	See Note	NSS	Seal, Piston (Note: Use Item 23)	
14	See Note	NSS	Ring, Wear (Note: Use Item 23)	
15	See Note	NSS	O-Ring (Note: Use Item 23)	
16	70005796	1	Nut	
17	0962292	4	Bearing	
18	70004233	1	Valve, Manual Descent	
19	70004232	1	Valve, Check	
20	70004231	1	Orifice	
21	70023370	4	Plug	
22	70005795	2	Fitting, Straight JIC	
23	70005797	1	Seal Kit - Cylinder (Includes Items 4, 6, 7, 9-11 & 13-15)	

SECTION 5 - CYLINDER

FIGURE 5-2. LIFT CYLINDER ASSEMBLY (MACHINES WITH SN STARTING WITH B2 & M2)

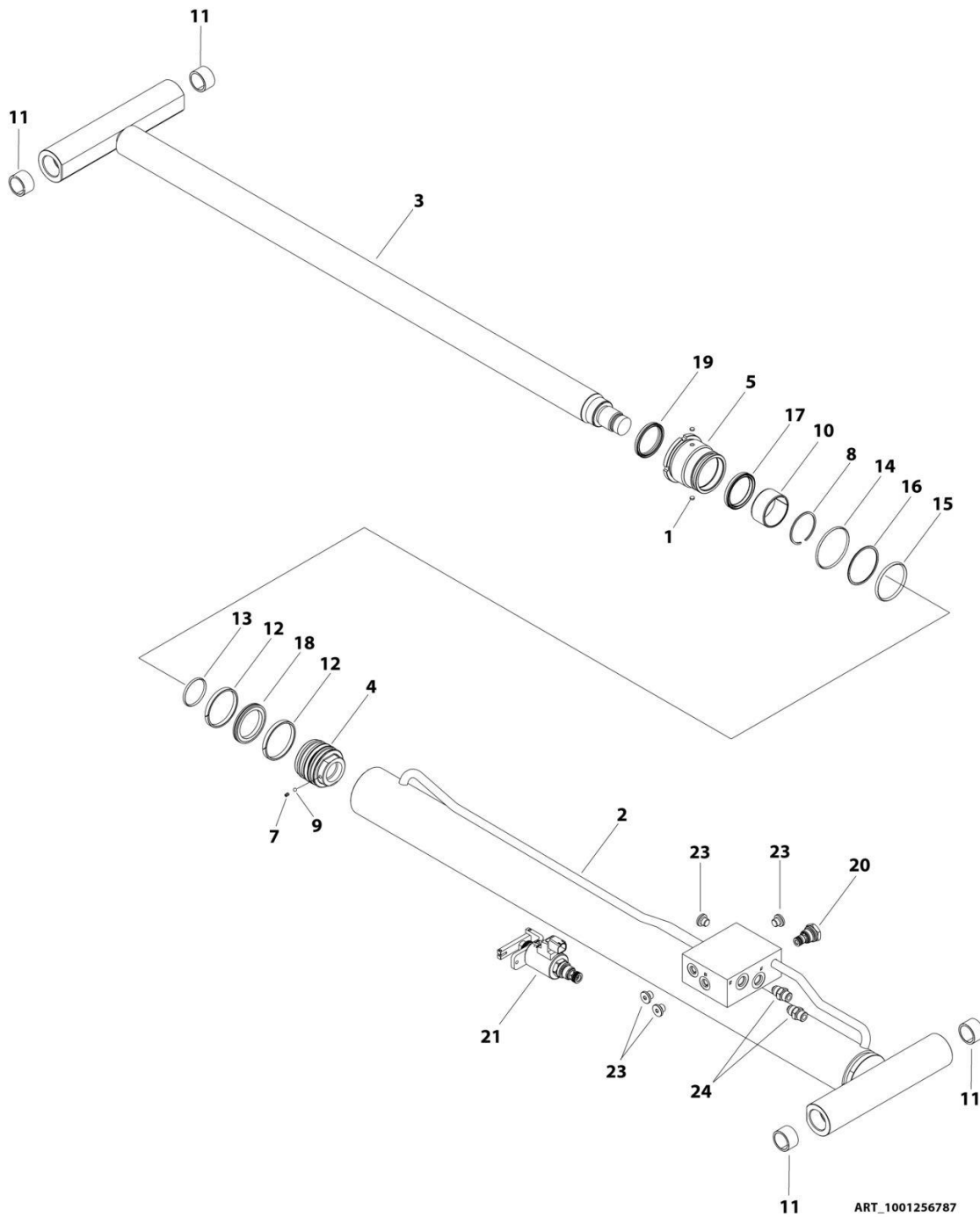

SECTION 5 - CYLINDER

FIGURE 5-2. LIFT CYLINDER ASSEMBLY (MACHINES WITH SN STARTING WITH B2 & M2)

ITEM	PART NUMBER	QTY	DESCRIPTION	REV
	1001256787	Ref	LIFT CYLINDER ASSEMBLY	A
		Ref	Note: Original Cylinder May Have Been Replaced with Service Replacement. Identify PN Stamped on Cylinder Before Ordering Parts.	
1	70003636	2	Lock	
2	See Note	NSS	Barrel (Note: Purchase Complete Assembly)	
3	70007572	1	Rod	
4	70007573	1	Piston	
5	70007574	1	Head	
6	70007575	1	Plug	
7	See Note	NSS	Setscrew (Note: Use Item 23)	
8	70007576	1	Ring, Retaining	
9	See Note	NSS	Ball, Steel (Note: Use Item 50)	
10	70007577	1	Bearing	
11	0962292	4	Bearing	
12	See Note	NSS	Ring, Wear (Note: Use Item 50)	
13	See Note	NSS	O-Ring (Note: Use Item 50)	
14	See Note	NSS	O-Ring (Note: Use Item 50)	
15	See Note	NSS	O-Ring (Note: Use Item 50)	
16	See Note	NSS	Ring, Back-up (Note: Use Item 50)	
17	See Note	NSS	Seal, Rod (Note: Use Item 50)	
18	See Note	NSS	Seal, Piston (Note: Use Item 50)	
19	See Note	NSS	Wiper (Note: Use Item 50)	
20	70004585	1	Cartridge, Valve (Bosch Rexroth)	
20	70008142	1	Cartridge, Valve (Sant - Valvole)	
21	70005236	1	Cartridge, Solenoid Valve (Bosch Rexroth)	
21	70008143	1	Cartridge, Solenoid Valve (Sant - Valvole)	
22	70007134	2	Fitting, Straight (Not Shown)	
23	2220883	4	Plug	
24	70007135	2	Fitting, Straight	
50	70007578	1	Seal Kit - Cylinder (Includes Items 7, 9 & 12-19)	

SECTION 5 - CYLINDER

FIGURE 5-3. LIFT CYLINDER ASSEMBLY (MACHINES WITH SN STARTING WITH G2)

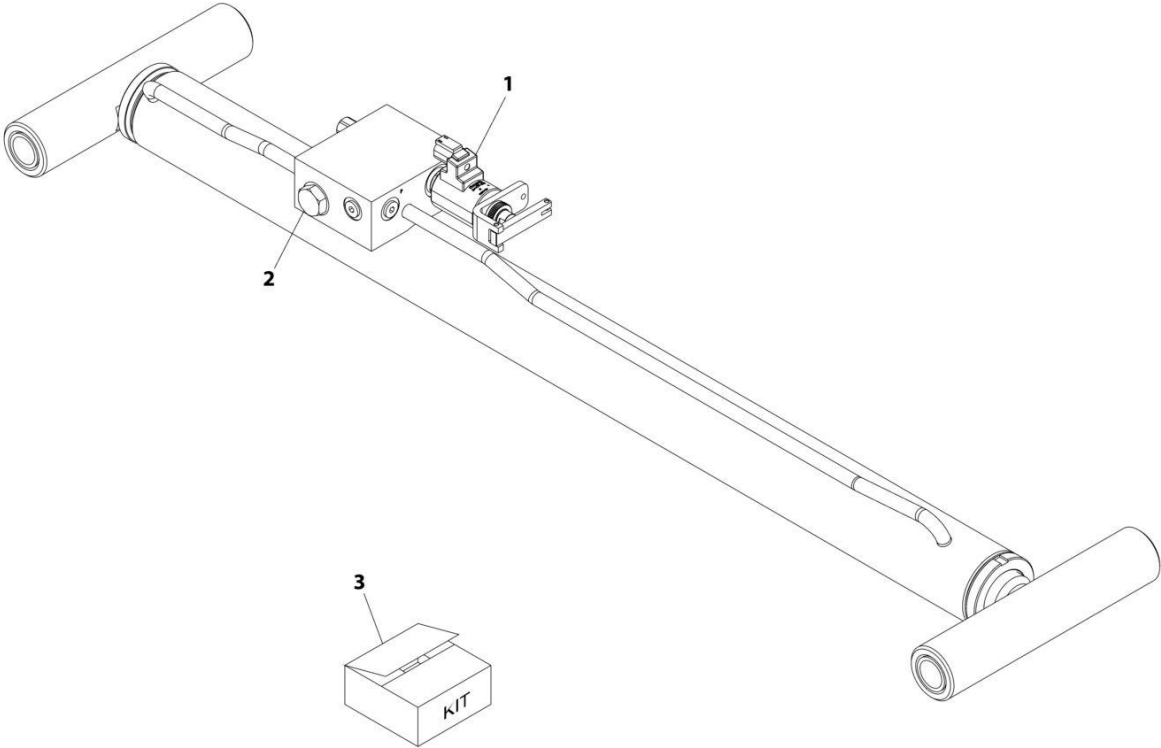

ART_1001276734

SECTION 5 - CYLINDER

FIGURE 5-3. LIFT CYLINDER ASSEMBLY (MACHINES WITH SN STARTING WITH G2)

ITEM	PART NUMBER	QTY	DESCRIPTION	REV
	1001276734	Ref	LIFT CYLINDER ASSEMBLY	A
		Ref	Note: Original Cylinder May Have Been Replaced with Service Replacement. Identify PN Stamped on Cylinder Before Ordering Parts.	
		Ref	Note: No Other Service Parts Available.	
1	70005236	1	Valve, Lowering	
2	70004585	1	Cartridge, Valve	
3	70007991	1	Seal Kit - 1001276734 Cylinder	

SECTION 5 - CYLINDER

FIGURE 5-4. STEER CYLINDER ASSEMBLY (MACHINES WITH SN STARTING WITH M2)

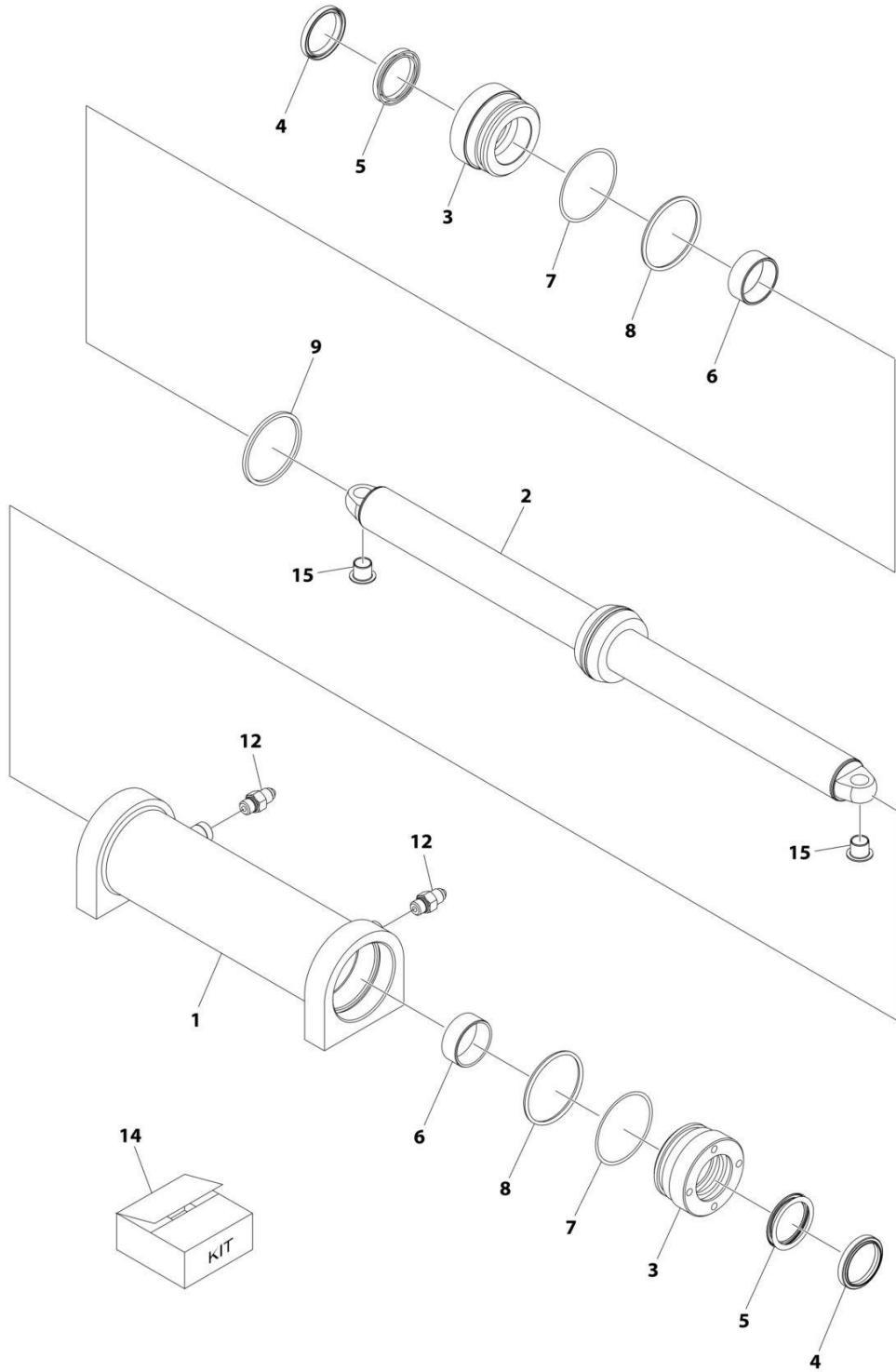

ART_1001220570_B

SECTION 5 - CYLINDER

FIGURE 5-4. STEER CYLINDER ASSEMBLY (MACHINES WITH SN STARTING WITH M2)

ITEM	PART NUMBER	QTY	DESCRIPTION	REV
	1001220570	Ref	STEER CYLINDER ASSEMBLY	B
		Ref	Note: See Usage Chart on Illustration before ordering parts.	
		Ref	Note: Original Cylinder May Have Been Replaced with Service Replacement. Identify PN Stamped on Cylinder Before Ordering Parts.	
1	70005798	1	Barrel	
2	70006143	1	Rod	
3	70004241	2	Head	
4	See Note	NSS	Wiper (Note: Use Item 14)	
5	See Note	NSS	Seal (Note: Use Item 14)	
6	70005800	2	Spacer	
7	See Note	NSS	O-Ring (Note: Use Item 14)	
8	See Note	NSS	Ring, Back-up (Note: Use Item 14)	
9	See Note	NSS	Seal, Piston (Note: Use Item 14)	
12	70005803	2	Fitting, Straight JIC	
14	70005805	1	Seal Kit - Cylinder (Includes Items 4, 5 & 7-9)	
15	0440259	2	Bushing	

SECTION 5 - CYLINDER

FIGURE 5-5. STEER CYLINDER ASSEMBLY (MACHINES WITH SN STARTING WITH B2)

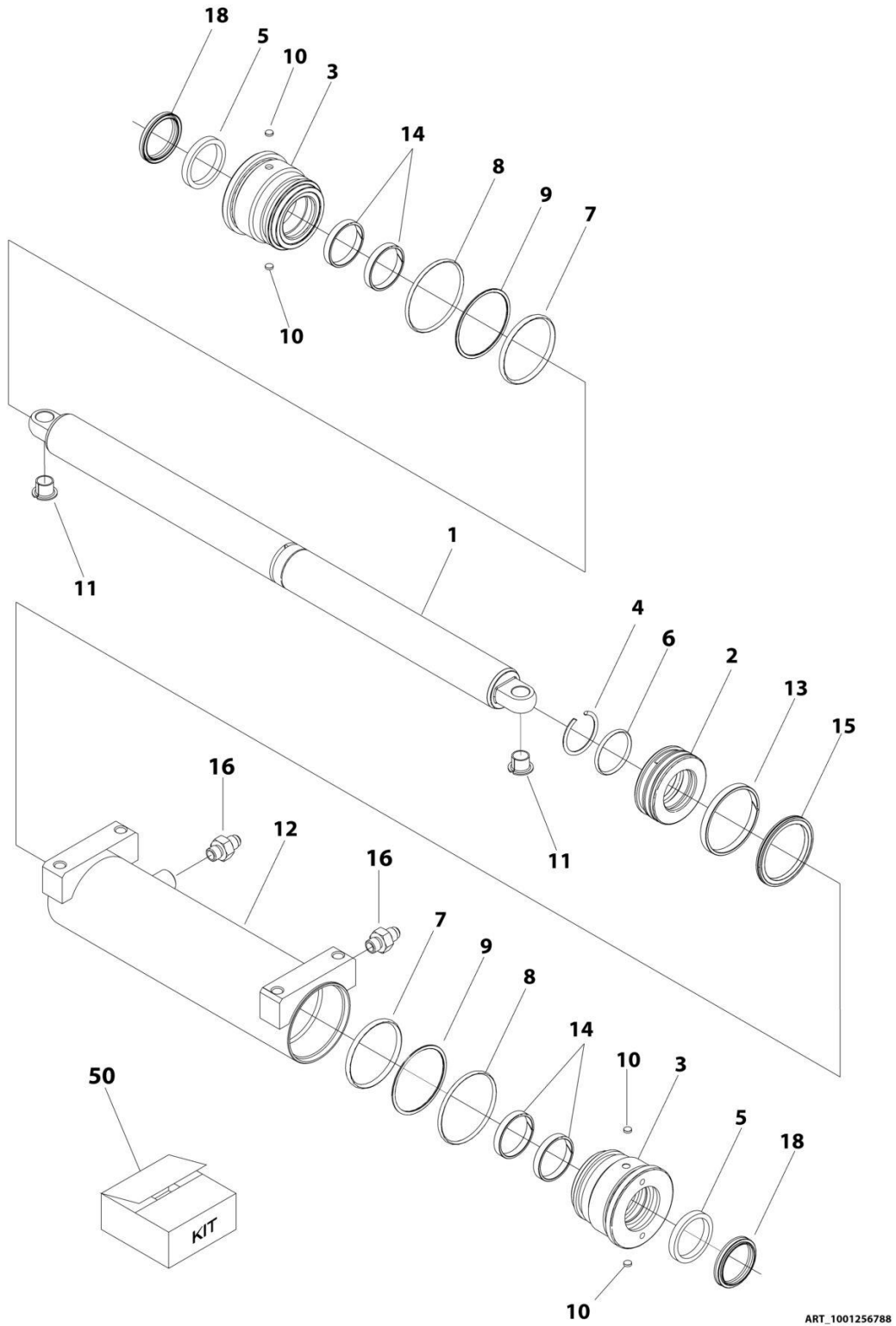

SECTION 5 - CYLINDER

FIGURE 5-5. STEER CYLINDER ASSEMBLY (MACHINES WITH SN STARTING WITH B2)

ITEM	PART NUMBER	QTY	DESCRIPTION	REV
	1001256788	Ref	STEER CYLINDER ASSEMBLY	A
		Ref	Note: Original Cylinder May Have Been Replaced with Service Replacement. Identify PN Stamped on Cylinder Before Ordering Parts.	
1	70007579	1	Rod	
2	70007580	1	Piston	
3	70007581	2	Head	
4	70007077	1	Ring, Retaining	
5	See Note	NSS	Seal, Rod (Note: Use Item 50)	
6	See Note	NSS	O-Ring (Note: Use Item 50)	
7	See Note	NSS	O-Ring (Note: Use Item 50)	
8	See Note	NSS	O-Ring (Note: Use Item 50)	
9	See Note	NSS	Ring, Back-up (Note: Use Item 50)	
10	70003636	4	Lock	
11	0440259	2	Bearing	
12	See Note	NSS	Barrel (Note: Purchase Complete Assembly)	
13	See Note	NSS	Ring, Wear (Note: Use Item 50)	
14	See Note	NSS	Ring, Wear (Note: Use Item 50)	
15	See Note	NSS	Seal, Piston (Note: Use Item 50)	
16	70007079	2	Fitting	
18	See Note	NSS	Wiper (Note: Use Item 50)	
50	70007118	1	Seal Kit - Cylinder (Includes Items 5-9,13-15 & 18)	

SECTION 5 - CYLINDER

FIGURE 5-6. STEER CYLINDER ASSEMBLY (MACHINES WITH SN STARTING WITH G2)

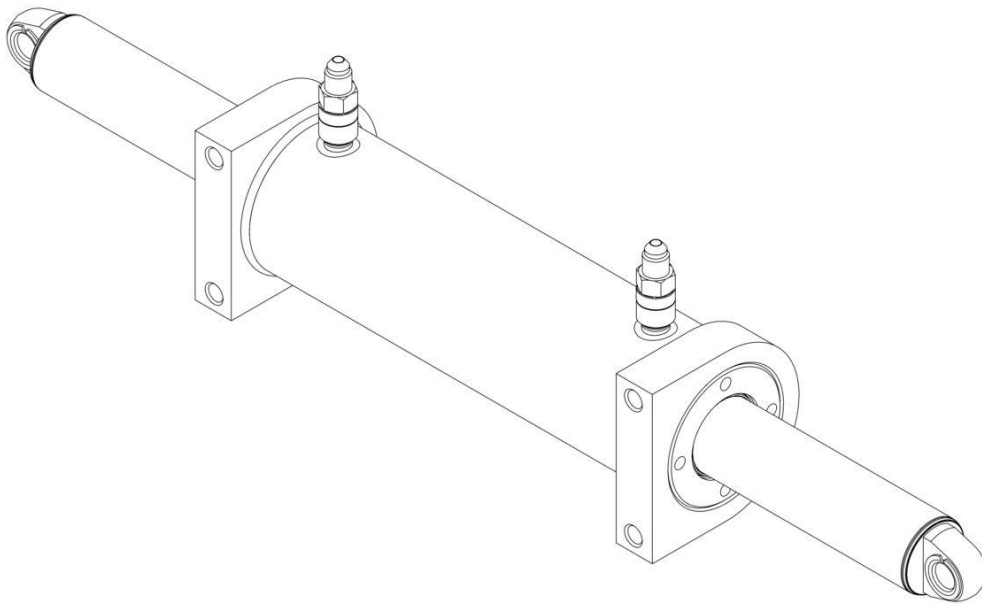

ART_1001276701

SECTION 5 - CYLINDER

FIGURE 5-6. STEER CYLINDER ASSEMBLY (MACHINES WITH SN STARTING WITH G2)

ITEM	PART NUMBER	QTY	DESCRIPTION	REV
	1001276701	Ref	STEER CYLINDER ASSEMBLY	A
		Ref	Note: No Other Service Parts Available..	
		Ref	Note: Original Cylinder May Have Been Replaced with Service Replacement. Identify PN Stamped on Cylinder Before Ordering Parts.	
	70008472	1	Kit, Seal - 1001276701 Cylinder	

SECTION 6 - HYDRAULIC

SECTION 6 - HYDRAULIC

FIGURE 6-1. HYDRAULIC DIAGRAM

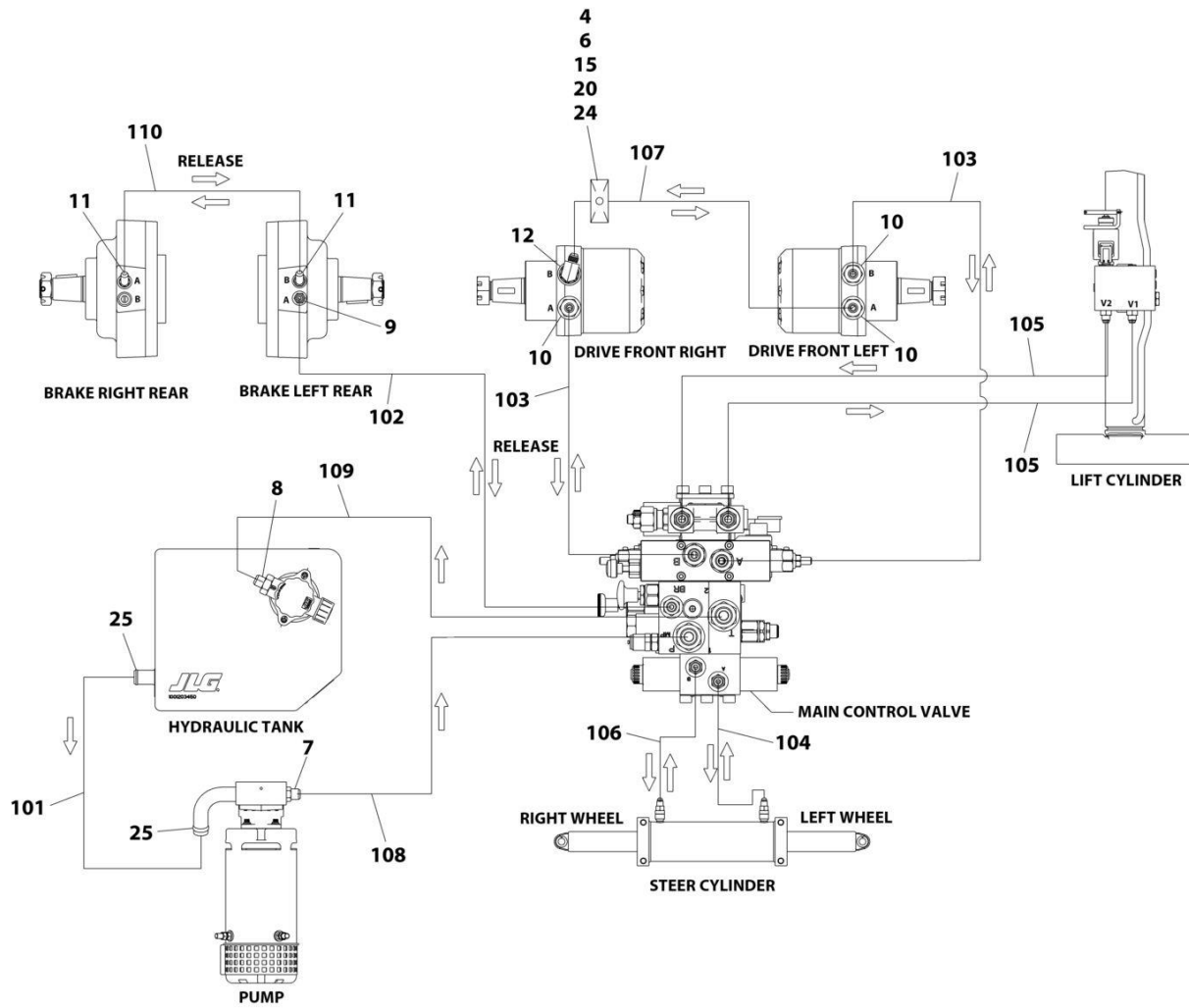

ART_1001253358_C_20F2

SECTION 6 - HYDRAULIC

FIGURE 6-1. HYDRAULIC DIAGRAM

ITEM	PART NUMBER	QTY	DESCRIPTION	REV
	1001253358	Ref	HYDRAULIC DIAGRAM	C
4	0760827	1	Bolt M8 x 100	
6	1321752	2	Clamp	
7	2220373	1	Fitting, Straight JIC/ORB	
8	2220375	1	Fitting, Straight JIC/ORB	
9	2220415	1	Fitting, Straight JIC/ORB	
10	2220497	3	Fitting, Straight JIC/ORB	
11	2220502	2	Fitting, 45 JIC/ORB	
12	2220828	1	Fitting, 90 JIC/ORB	
15	3290805	1	Nut M8	
17	4240017	AR	Tie-Strap (Not Shown)	
20	4811900	2	Washer M8	
24	8750014	2	Clamp	
25	1001143501	2	Clamp	
100	1001255506	1	Hose Kit (Not Shown)	A
101	1001203835	1	Hose	
102	1001203837	1	Hose	
103	1001203838	2	Hose	
104	1001203839	1	Hose	
105	1001203840	2	Hose	
106	1001203844	1	Hose	
107	1001203846	1	Hose	
108	1001254225	1	Hose	
109	1001254226	1	Hose	
110	1001254227	1	Hose	

SECTION 6 - HYDRAULIC

FIGURE 6-2. HYDRAULIC DIAGRAM (WITH BUCHER PUMP/MOTOR)

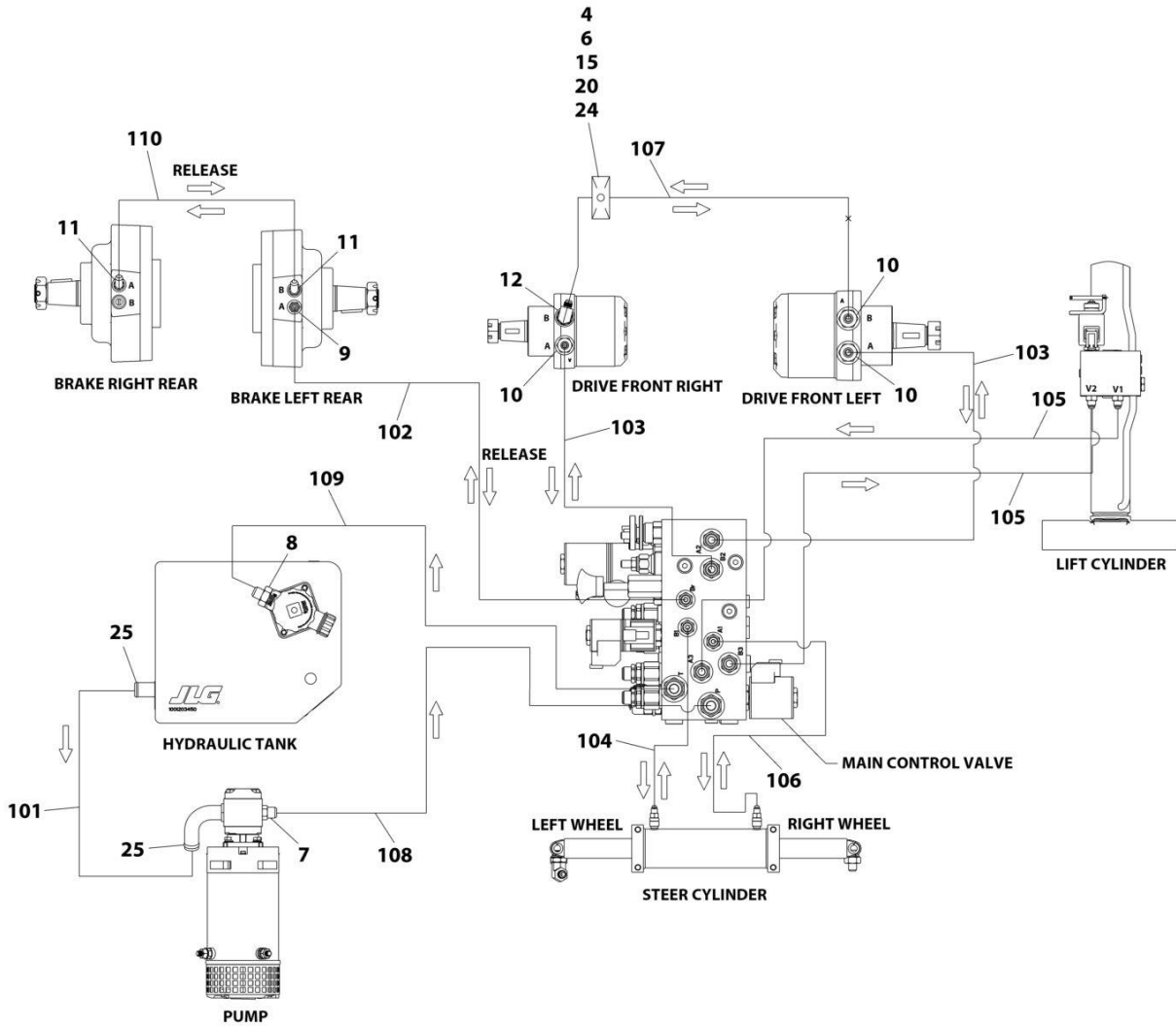

ART_1001276592_20F2

SECTION 6 - HYDRAULIC

FIGURE 6-2. HYDRAULIC DIAGRAM (WITH BUCHER PUMP/MOTOR)

ITEM	PART NUMBER	QTY	DESCRIPTION	REV
	1001276592	Ref	HYDRAULIC DIAGRAM	A
4	0760827	1	Bolt M8 x 100	
6	1321752	2	Clamp	
7	2220373	1	Fitting, Straight JIC/ORB	
8	2220375	1	Fitting, Straight JIC/ORB	
9	2220415	1	Fitting, Straight JIC/ORB	
10	2220497	3	Fitting, Straight JIC/ORB	
11	2220502	2	Fitting, 45 JIC/ORB	
12	2220828	1	Fitting, 90 JIC/ORB	
15	3290805	1	Nut M8	
17	4240017	AR	Tie-Strap (Not Shown)	
20	4811900	2	Washer M8	
24	8750014	2	Clamp	
25	1001143501	2	Clamp	
100	1001278904	Ref	Hose Kit (Not Shown)	A
101	1001278882	1	Hose	
102	1001203837	1	Hose	
103	1001203838	2	Hose	
104	1001203839	1	Hose	
105	1001203840	2	Hose	
106	1001203844	1	Hose	
107	1001203846	1	Hose	
108	1001254225	1	Hose	
109	1001254226	1	Hose	
110	1001254227	1	Hose	

SECTION 7 - ELECTRICAL

SECTION 7 - ELECTRICAL

FIGURE 7-1. AC BOX AT PLATFORM INSTALLATION - 110V GFI (ANSI, ANSI EXPORT, CHINA, CSA, JAPANESE AND KOREA SPECS)

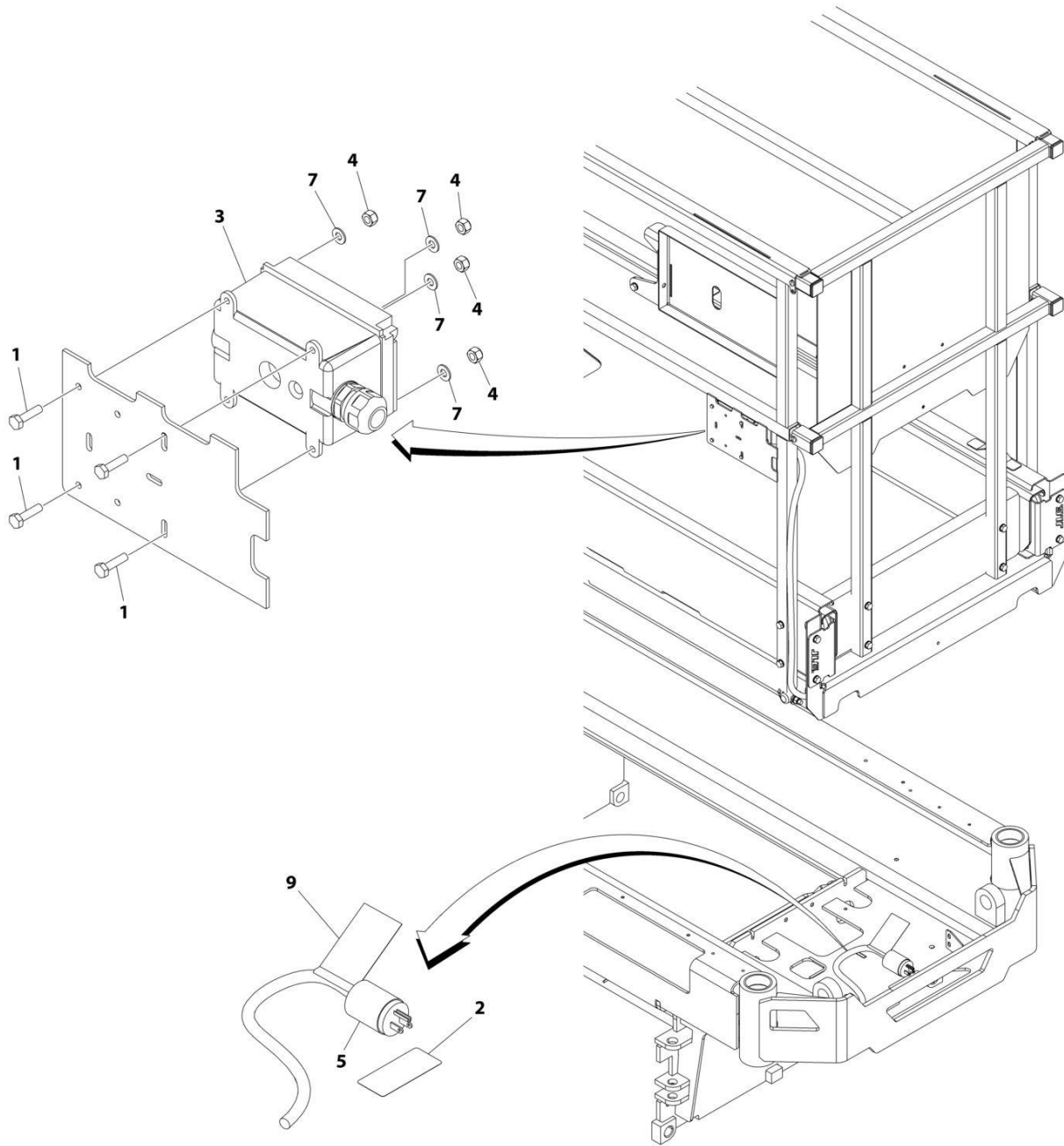

ART_1001208930

SECTION 7 - ELECTRICAL

FIGURE 7-1. AC BOX AT PLATFORM INSTALLATION - 110V GFI (ANSI, ANSI EXPORT, CHINA, CSA, JAPANESE AND KOREA SPECS)

ITEM	PART NUMBER	QTY	DESCRIPTION	REV
	1001208930	Ref	AC BOX AT PLATFORM INSTALLATION - 110V GFI	C
1	0760408	4	Bolt M4 x 16	
2	1703464	1	Decal - AC Power	
3	2902431	1	Receptacle Box Kit (See Separate Breakdown in this Section)	
4	3290405	4	Nut M4	
5	4460138	1	Plug, Male - AC	
6	4460315	1	Terminal (Not Shown)	
7	4811400	4	Washer M4	
9	1001102258	1	Decal - AC Label	
10	4240017	AR	Tie-Strap (Not Shown)	

SECTION 7 - ELECTRICAL

FIGURE 7-2. AC BOX AT PLATFORM INSTALLATION - 110V IEC YELLOW (CE & UK CA SPECS)

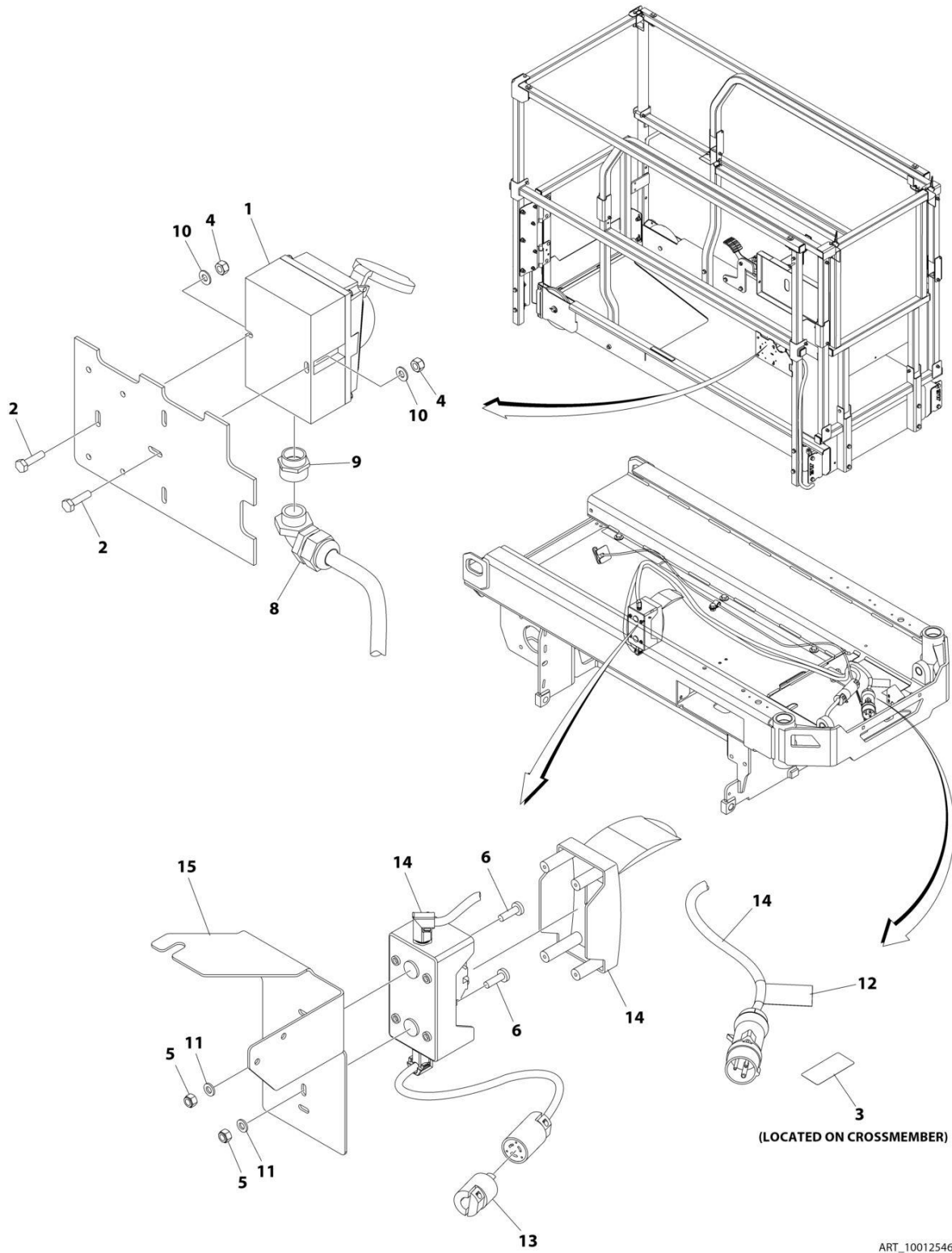

SECTION 7 - ELECTRICAL

FIGURE 7-2. AC BOX AT PLATFORM INSTALLATION - 110V IEC YELLOW (CE & UK CA SPECS)

ITEM	PART NUMBER	QTY	DESCRIPTION	REV
	1001254639	Ref	AC BOX AT PLATFORM INSTALLATION - 110V IEC YELLOW	A
1	0275216	1	Receptacle Box Kit - 110V IEC Yellow (See Separate Breakdown in this Section)	
2	0760408	2	Bolt M4 x 16	
3	1703464	1	Decal - AC Power	
4	3290405	2	Nut M4	
5	3290605	2	Nut M6	
6	4010610	2	Screw M6 x 20	
7	4240017	AR	Tie-Strap (Not Shown)	
8	4461257	1	Connector, Strain Relief	
9	4461258	1	Connector, Adapter	
10	4811400	2	Washer M4	
11	4811700	4	Washer M6	
12	1001102258	1	Decal - AC Label	
13	1001120204	1	Plug, Male Twist	
14	1001209776	1	Breaker Box Kit (See Separate Breakdown in this Section)	
15	1001253280	1	Bracket	

SECTION 7 - ELECTRICAL

FIGURE 7-3. AC BOX AT PLATFORM INSTALLATION - 220V IEC BLUE (CE & UK CA SPECS)

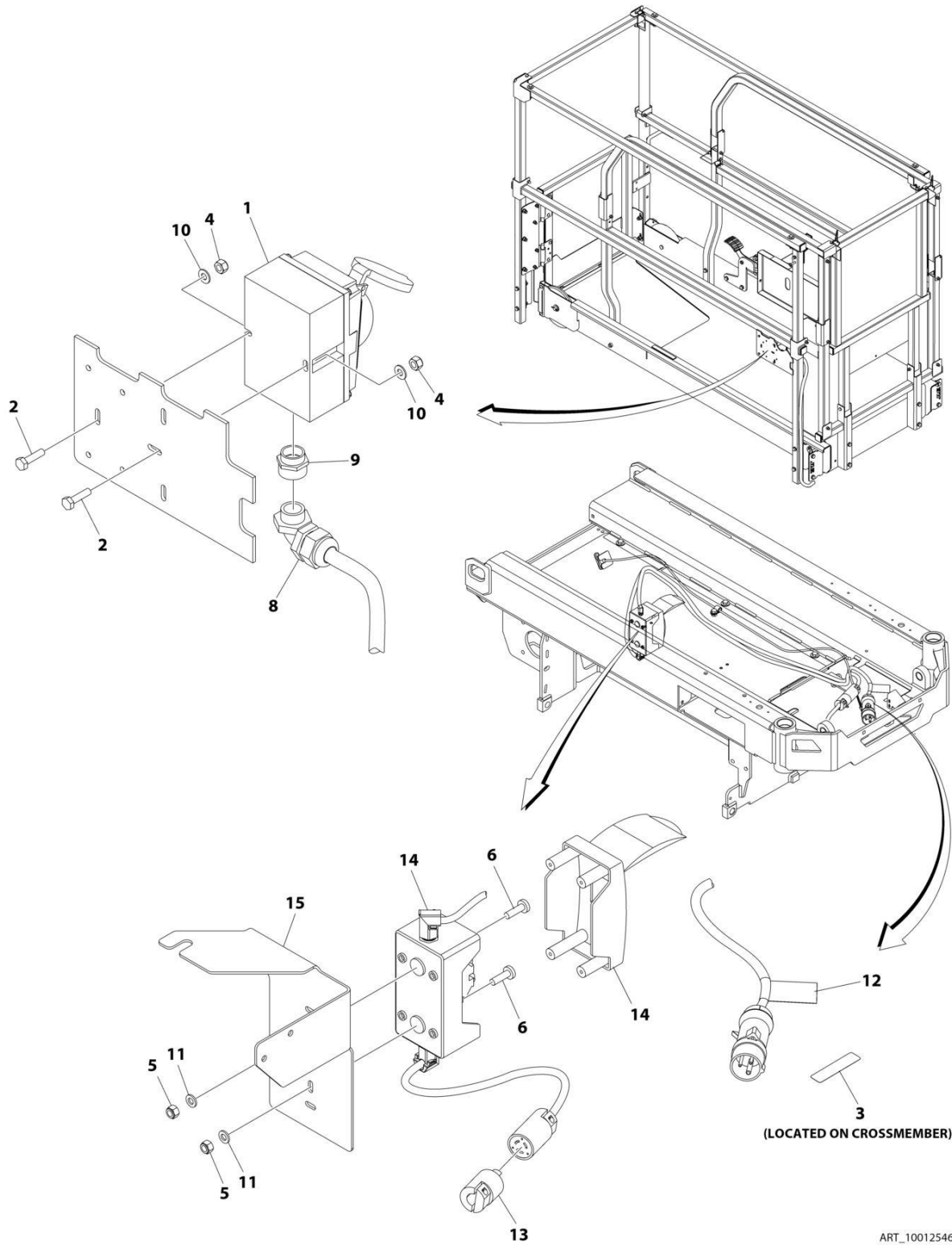

ART_1001254640

SECTION 7 - ELECTRICAL

FIGURE 7-3. AC BOX AT PLATFORM INSTALLATION - 220V IEC BLUE (CE & UK CA SPECS)

ITEM	PART NUMBER	QTY	DESCRIPTION	REV
	1001254640	Ref	AC BOX AT PLATFORM INSTALLATION - 220V IEC BLUE	A
1	0275217	1	Receptacle Box Kit - 220V IEC Blue (See Separate Breakdown in this Section)	
2	0760408	2	Bolt M4 x 16	
3	3252507	1	Decal - AC Power	
4	3290405	2	Nut M4	
5	3290605	2	Nut M6	
6	4010610	2	Screw M6 x 20	
7	4240017	AR	Tie-Strap (Not Shown)	
8	4461257	1	Connector, Strain Relief	
9	4461258	1	Connector, Adapter	
10	4811400	2	Washer M4	
11	4811700	4	Washer M6	
12	1001102258	1	Decal - AC Label	
13	1001120204	1	Plug, Male Twist	
14	1001209776	1	Breaker Box Kit (See Separate Breakdown in this Section)	
15	1001253280	1	Bracket	

SECTION 7 - ELECTRICAL

FIGURE 7-4. AC BOX AT PLATFORM INSTALLATION - 220V CEE7 POST GROUND (CE & UK CA SPECS)

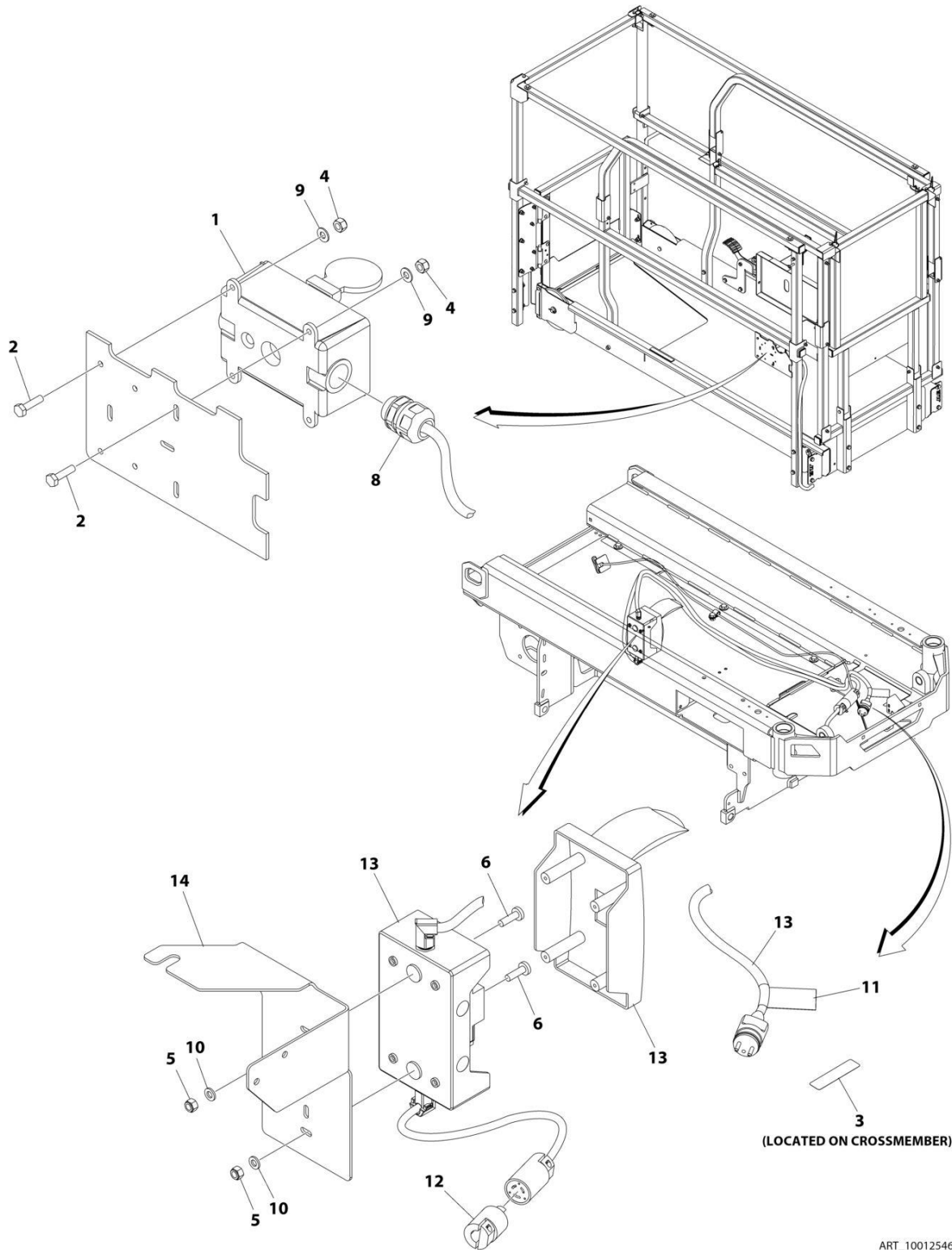

ART_1001254636

SECTION 7 - ELECTRICAL

FIGURE 7-4. AC BOX AT PLATFORM INSTALLATION - 220V CEE7 POST GROUND (CE & UK CA SPECS)

ITEM	PART NUMBER	QTY	DESCRIPTION	REV
	1001254636	Ref	AC BOX AT PLATFORM INSTALLATION - 220V CEE7 POST GROUND	A
1	0275452	1	Receptacle Box Kit - 220V CEE7 Post Ground (See Separate Breakdown in this Section)	
2	0760408	4	Bolt M4 x 16	
3	3252507	1	Decal - AC Power	
4	3290405	4	Nut M4	
5	3290605	2	Nut M6	
6	4010610	2	Screw M6 x 20	
7	4240017	AR	Tie-Strap (Not Shown)	
8	4460662	1	Connector, Strain Relief	
9	4811400	4	Washer M4	
10	4811700	4	Washer M6	
11	1001102258	1	Decal - AC Label	
12	1001120204	1	Plug, Male Twist	
13	1001209482	1	Breaker Box Kit (See Separate Breakdown in this Section)	
14	1001253280	1	Bracket	

SECTION 7 - ELECTRICAL

FIGURE 7-5. AC BOX AT PLATFORM INSTALLATION - 220V CEE7 SIDE GROUND (CE & UK CA SPECS)

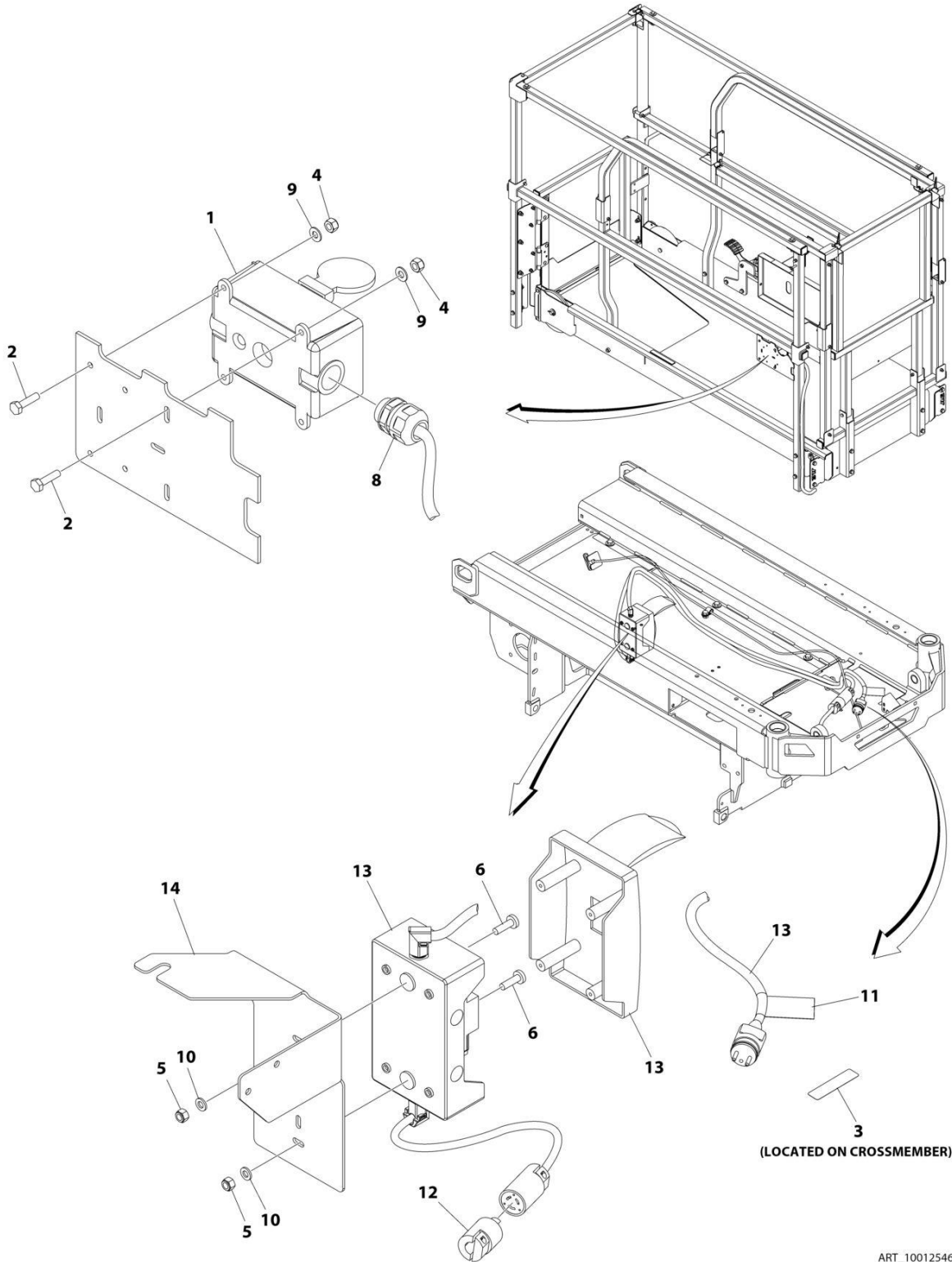

ART_1001254637

SECTION 7 - ELECTRICAL

FIGURE 7-5. AC BOX AT PLATFORM INSTALLATION - 220V CEE7 SIDE GROUND (CE & UK CA SPECS)

ITEM	PART NUMBER	QTY	DESCRIPTION	REV
	1001254637	Ref	AC BOX AT PLATFORM INSTALLATION - 220V CEE7 SIDE GROUND	A
1	0275453	1	Receptacle Box Kit - 220V CEE7 Side Ground (See Separate Breakdown in this Section)	
2	0760408	4	Bolt M4 x 16	
3	3252507	1	Decal - AC Power	
4	3290405	4	Nut M4	
5	3290605	2	Nut M6	
6	4010610	2	Screw M6 x 20	
7	4240017	AR	Tie-Strap (Not Shown)	
8	4460662	1	Connector, Strain Relief	
9	4811400	4	Washer M4	
10	4811700	4	Washer M6	
11	1001102258	1	Decal - AC Label	
12	1001120204	1	Plug, Male Twist	
13	1001209482	1	Breaker Box Kit (See Separate Breakdown in this Section)	
14	1001253280	1	Bracket	

SECTION 7 - ELECTRICAL

FIGURE 7-6. AC BOX AT PLATFORM INSTALLATION - 220V AFSINT 107 (CE & UK CA SPECS)

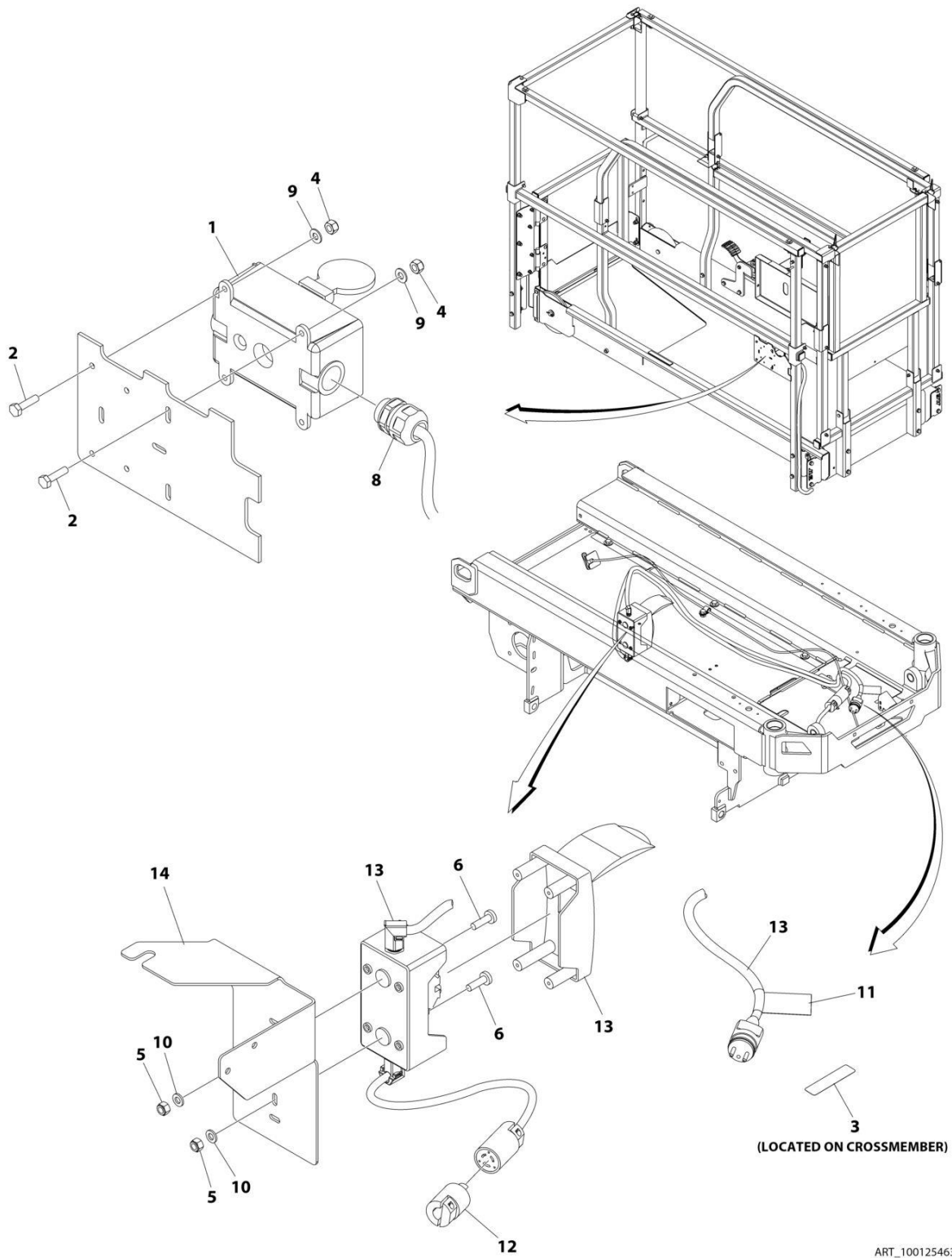

ART_1001254638

SECTION 7 - ELECTRICAL

FIGURE 7-6. AC BOX AT PLATFORM INSTALLATION - 220V AFSINT 107 (CE & UK CA SPECS)

ITEM	PART NUMBER	QTY	DESCRIPTION	REV
	1001254638	Ref	AC BOX AT PLATFORM INSTALLATION - 220V AFSINT 107	A
1	0275454	1	Receptacle Box Kit - 220V AFSINT 107 (See Separate Breakdown in this Section)	
2	0760408	4	Bolt M4 x 16	
3	3252507	1	Decal - AC Power	
4	3290405	4	Nut M4	
5	3290605	2	Nut M6	
6	4010610	2	Screw M6 x 20	
7	4240017	AR	Tie-Strap (Not Shown)	
8	4460662	1	Connector, Strain Relief	
9	4811400	4	Washer M4	
10	4811700	4	Washer M6	
11	1001102258	1	Decal - AC Label	
12	1001120204	1	Plug, Male Twist	
13	1001209776	1	Breaker Box Kit (See Separate Breakdown in this Section)	
14	1001253280	1	Bracket	

SECTION 7 - ELECTRICAL

FIGURE 7-7. AC BOX AT PLATFORM INSTALLATION - 220V CHINA PLUG (CHINA SPECS)

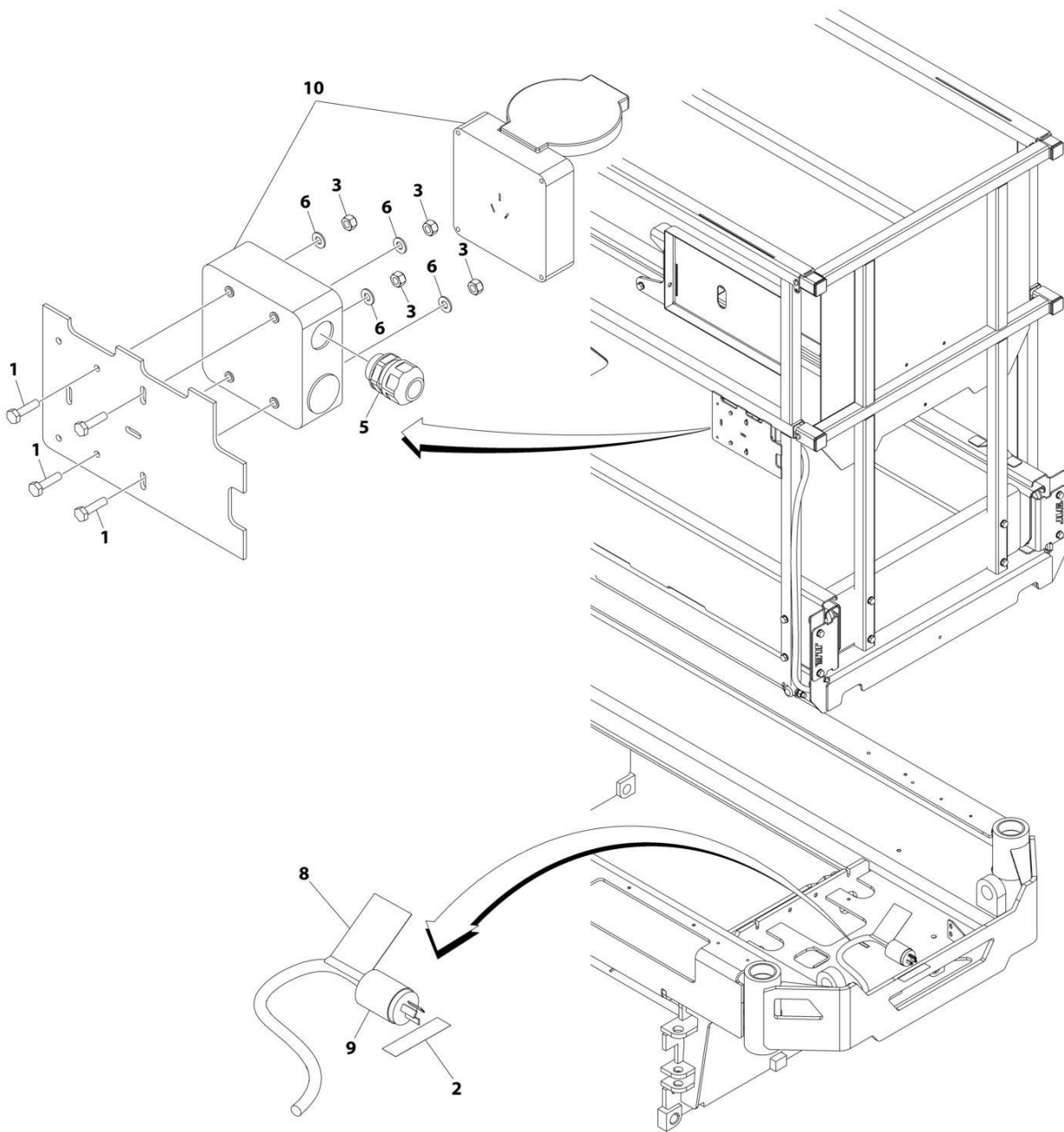

ART_1001208938

SECTION 7 - ELECTRICAL

FIGURE 7-7. AC BOX AT PLATFORM INSTALLATION - 220V CHINA PLUG (CHINA SPECS)

ITEM	PART NUMBER	QTY	DESCRIPTION	REV
	1001208938	Ref	AC BOX AT PLATFORM INSTALLATION - 220V CHINA PLUG	B
1	0760408	4	Bolt M4 x 16	
2	3252507	1	Decal - 220 Volt	
3	3290405	4	Nut M4	
4	4460315	1	Terminal (Not Shown)	
5	4460968	1	Connector, Strain Relief	
6	4811400	4	Washer M4	
8	1001102258	1	Decal - AC Label	
9	1001187816	1	Plug	
10	1001188116	1	Box	
11	4240017	AR	Tie-Strap (Not Shown)	

SECTION 7 - ELECTRICAL

FIGURE 7-8. AC BOX AT PLATFORM INSTALLATION - 220V LOCALLY SUPPLIED COMPONENTS (ALL SPECS)

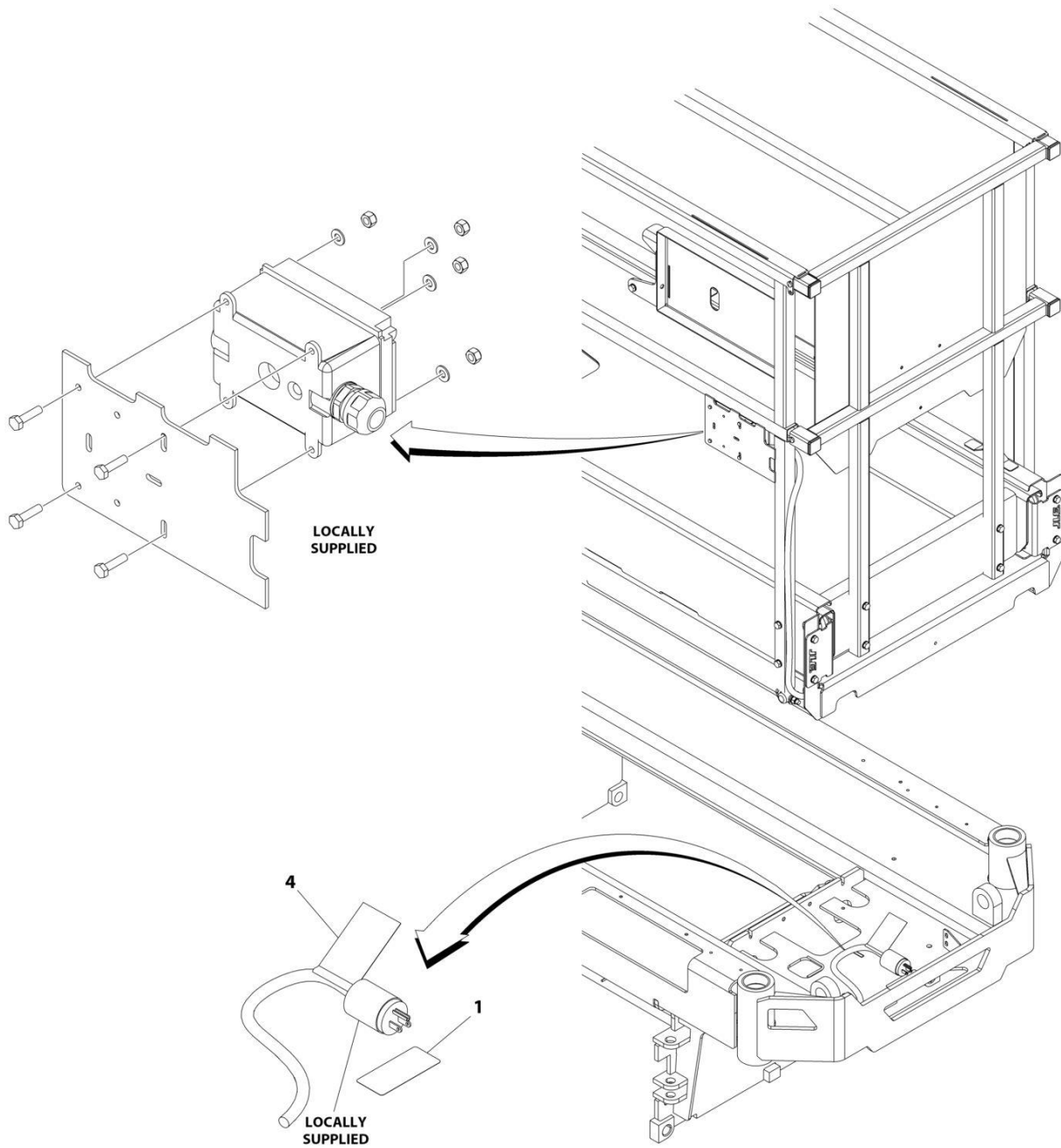

ART_1001208931

SECTION 7 - ELECTRICAL

**FIGURE 7-8. AC BOX AT PLATFORM INSTALLATION - 220V LOCALLY SUPPLIED COMPONENTS
(ALL SPECS)**

ITEM	PART NUMBER	QTY	DESCRIPTION	REV
	1001208931	Ref	AC BOX AT PLATFORM INSTALLATION - 220V LOCALLY SUPPLIED COMPONENTS	C
1	3252507	1	Decal - 220 Volt	
4	1001102258	1	Decal - AC Label	
5	4240017	AR	Tie-Strap (Not Shown)	

SECTION 7 - ELECTRICAL

FIGURE 7-9. BREAKER BOX KIT WITH 1 DOUBLE BREAKER

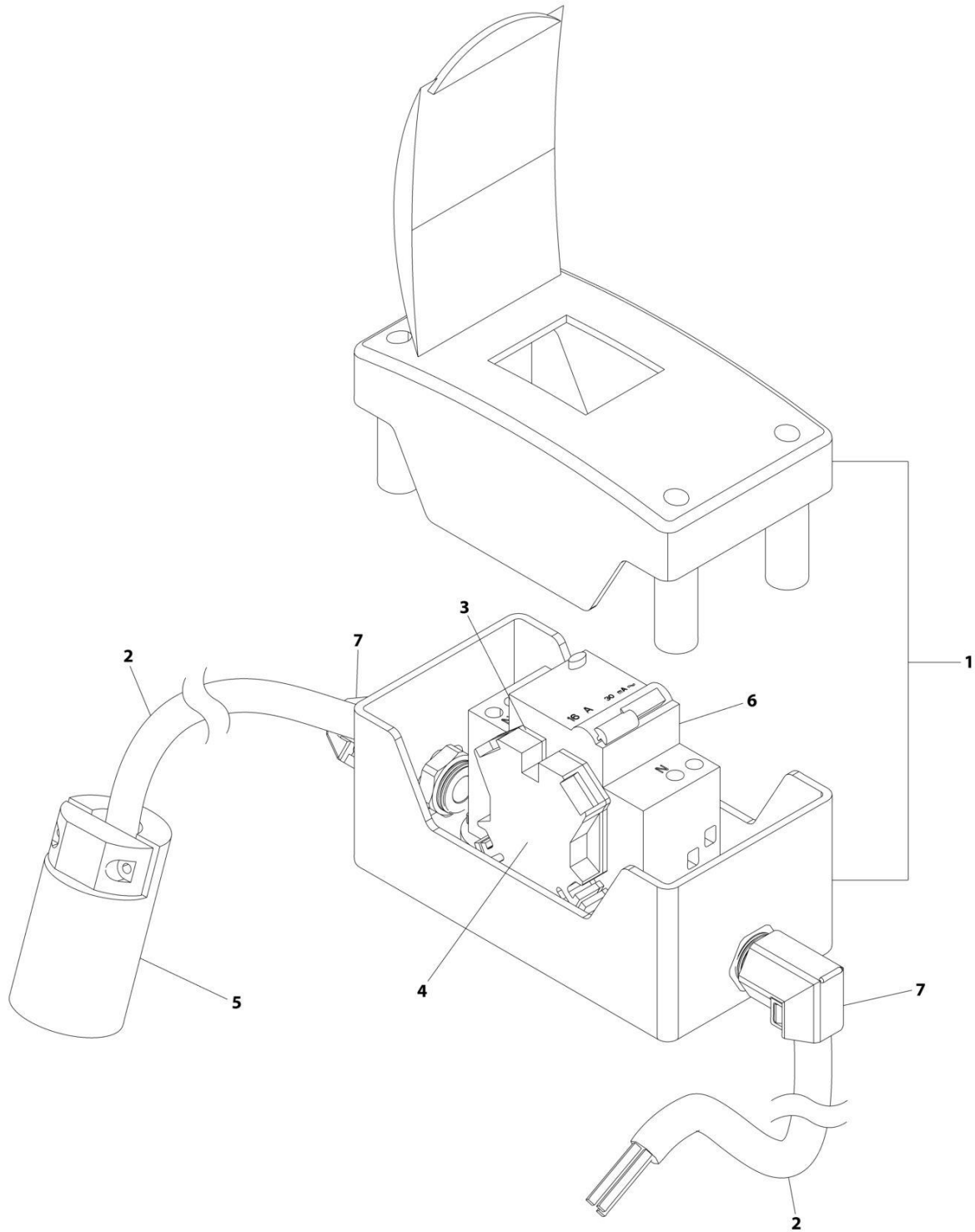

ART_1001209776

SECTION 7 - ELECTRICAL

FIGURE 7-9. BREAKER BOX KIT WITH 1 DOUBLE BREAKER

ITEM	PART NUMBER	QTY	DESCRIPTION	REV
	1001209776	Ref	BREAKER BOX KIT WITH 1 DOUBLE BREAKER	F
1	0861880	1	Box	
2	1060908	126 in /3.2m	Cable, 12/3	
3	4460956	1	Barrier, Terminal	
4	4460957	1	Block, Terminal	
5	1001120205	1	Connector, Female Twist	
6	1001181045	1	Breaker 30mAmp/16 Amp	
7	1001217164	2	Connector, Strain Relief 90	

SECTION 7 - ELECTRICAL

FIGURE 7-10. BREAKER BOX KIT WITH 3 BREAKERS

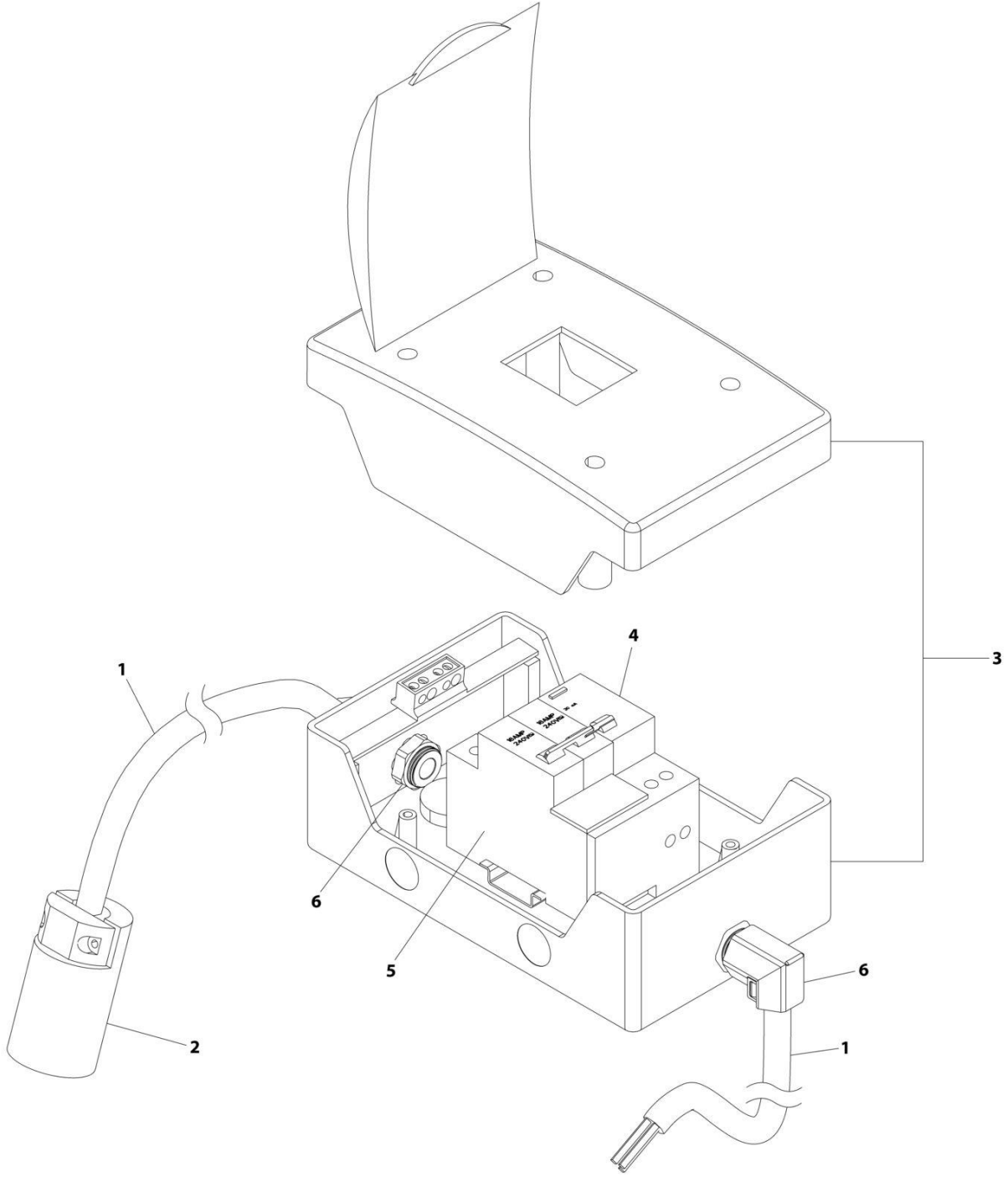

ART_1001209482

SECTION 7 - ELECTRICAL

FIGURE 7-10. BREAKER BOX KIT WITH 3 BREAKERS

ITEM	PART NUMBER	QTY	DESCRIPTION	REV
	1001209482	Ref	BREAKER BOX KIT WITH 3 BREAKERS	G
1	1060908	126 in /3.2m	Cable, 12/3	
2	1001120205	1	Connector, Female Twist	
3	1001152483	1	Box	
4	1001189171	1	Breaker, 30mAmp	
5	1001189172	1	Breaker 16 Amp, Double	
6	1001217164	2	Connector, Strain Relief 90	

SECTION 7 - ELECTRICAL

FIGURE 7-11. CHARGER HARNESS (CHARGER WITH COMMUNICATION PORT)

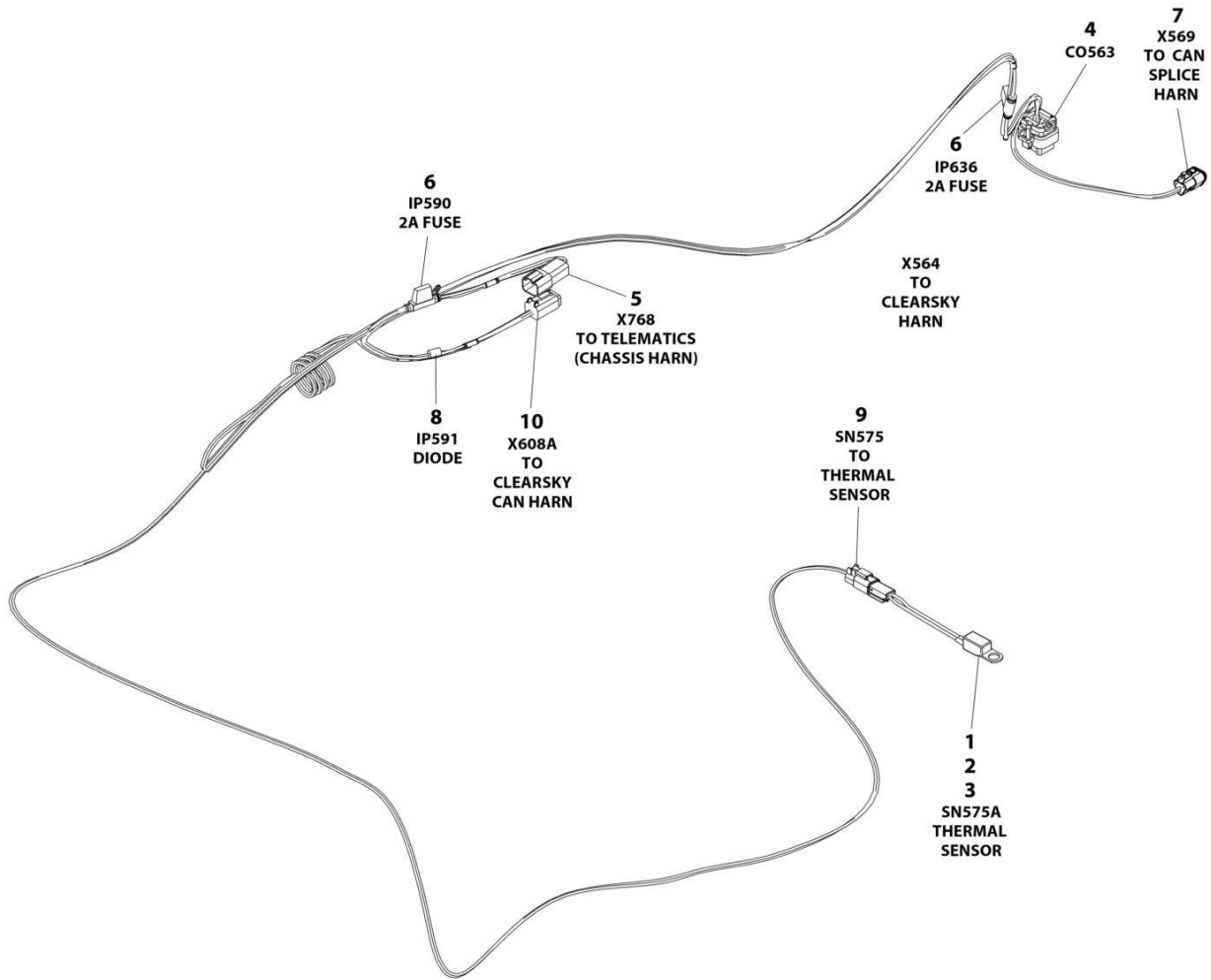

ART_1001254028_C

SECTION 7 - ELECTRICAL

FIGURE 7-11. CHARGER HARNESS (CHARGER WITH COMMUNICATION PORT)

ITEM	PART NUMBER	QTY	DESCRIPTION	REV
	1001254028	Ref	CHARGER HARNESS	C
1	4460464	2	Pin, Male	
2	4460897	1	Receptacle, Female - 2 Position	
3	1001102771	1	Sensor, Temperature	
4	4460872	1	Connector - 14 Position	
4	4460871	6	Terminal	
4	4460905	8	Plug, Terminal	
5	4460932	1	Receptacle, Female - 4 Position	
5	4460464	1	Pin, Male	
6	2400060	2	Fuseholder With Cover	
6	1001196634	2	Fuse 2A	
7	1001116812	1	Plug, Male - 3 Position	
7	4460944	2	Socket, Female	
7	4460466	1	Plug, Terminal	
8	3990001	1	Diode	
9	4460891	1	Plug, Male - 2 Position	
9	4460465	2	Socket, Female	
10	4460884	1	Plug, Male - 4 Position	
10	4460465	4	Socket, Female	

SECTION 7 - ELECTRICAL

FIGURE 7-12. CHARGER PLUG INSTALLATION - LOCALLY SUPPLIED PLUG (ALL SPECS)
(R1932i/R1932)

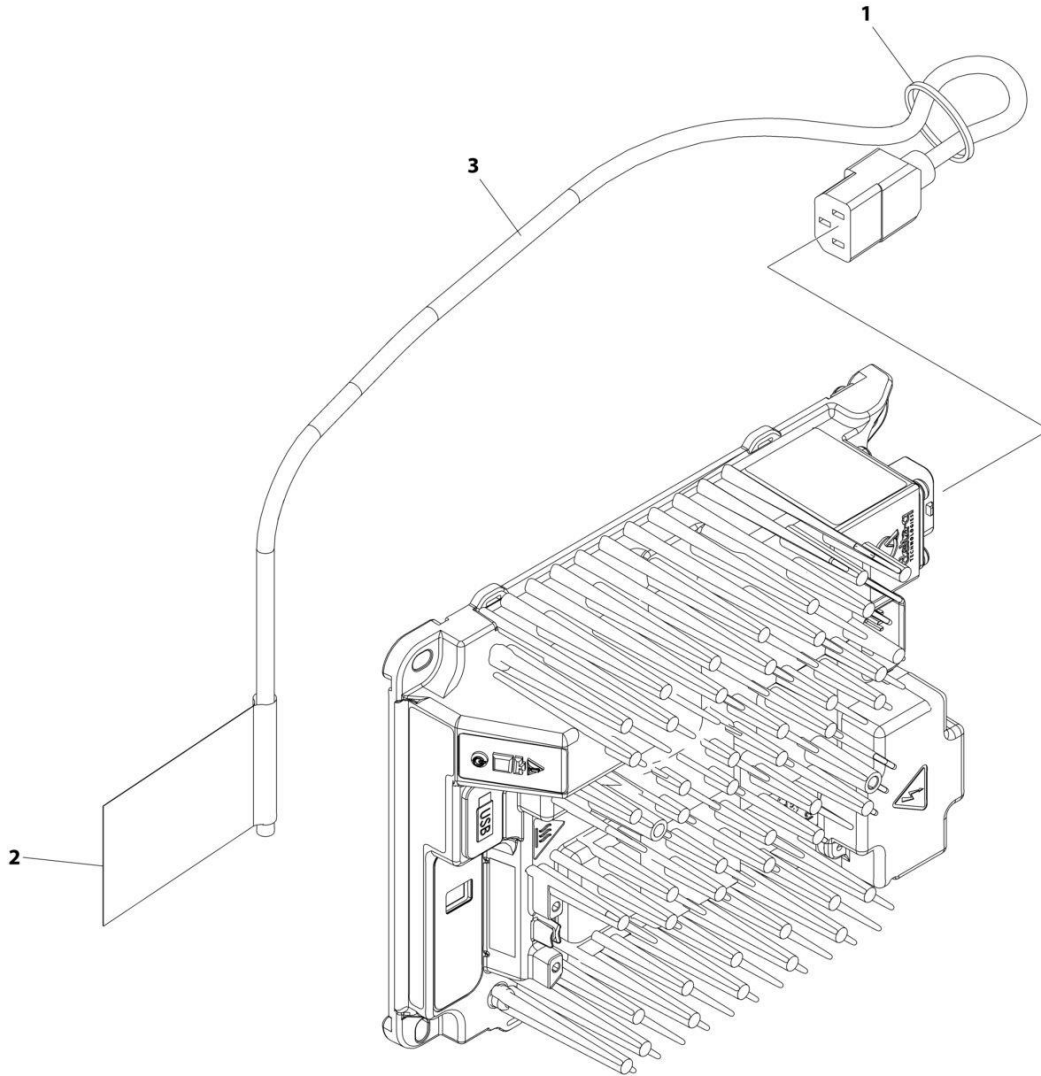

ART_1001248631

SECTION 7 - ELECTRICAL

**FIGURE 7-12. CHARGER PLUG INSTALLATION - LOCALLY SUPPLIED PLUG (ALL SPECS)
(R1932I/R1932)**

ITEM	PART NUMBER	QTY	DESCRIPTION	REV
	1001248631	Ref	CHARGER PLUG INSTALLATION	B
1	4240017	AR	Tie-Strap	
2	1001102489	1	Decal - Charger	
3	1001207974	1	Cable, Charger Plug (No Plug)	

SECTION 7 - ELECTRICAL

FIGURE 7-13. CHARGER PLUG INSTALLATION - 110V PLUG (ALL SPECS EXCEPT AUSTRALIAN, CE, KOREA & UK CA SPECS) (R1932i/R1932)

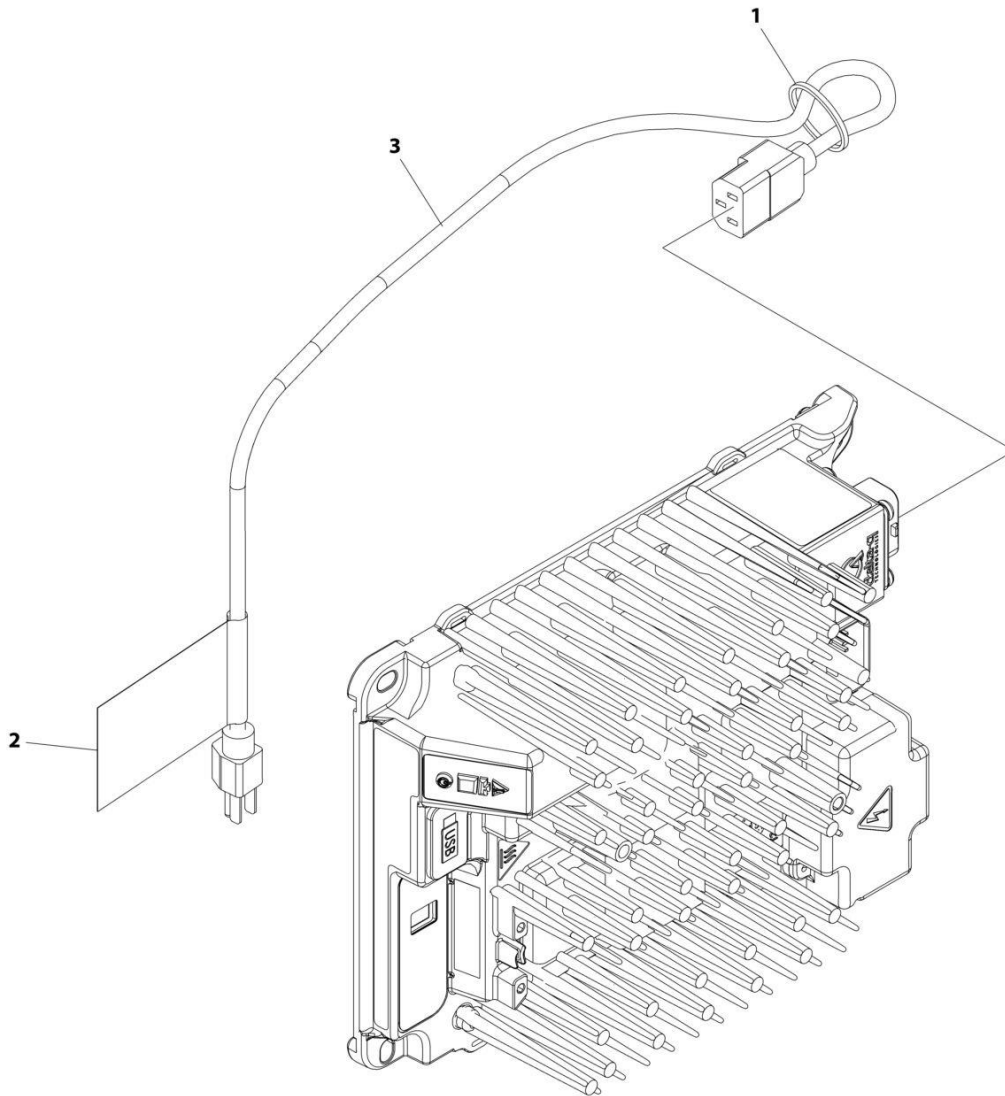

ART_1001248632

SECTION 7 - ELECTRICAL

FIGURE 7-13. CHARGER PLUG INSTALLATION - 110V PLUG (ALL SPECS EXCEPT AUSTRALIAN, CE, KOREA & UK CA SPECS) (R1932i/R1932)

ITEM	PART NUMBER	QTY	DESCRIPTION	REV
	1001248632	Ref	CHARGER PLUG INSTALLATION	B
1	4240017	AR	Tie-Strap	
2	1001102489	1	Decal - Charger	
3	1001207970	1	Cable, Charger Plug	

SECTION 7 - ELECTRICAL

FIGURE 7-14. CHARGER PLUG INSTALLATION (AUSTRALIAN PLUG) (R1932i/R1932)

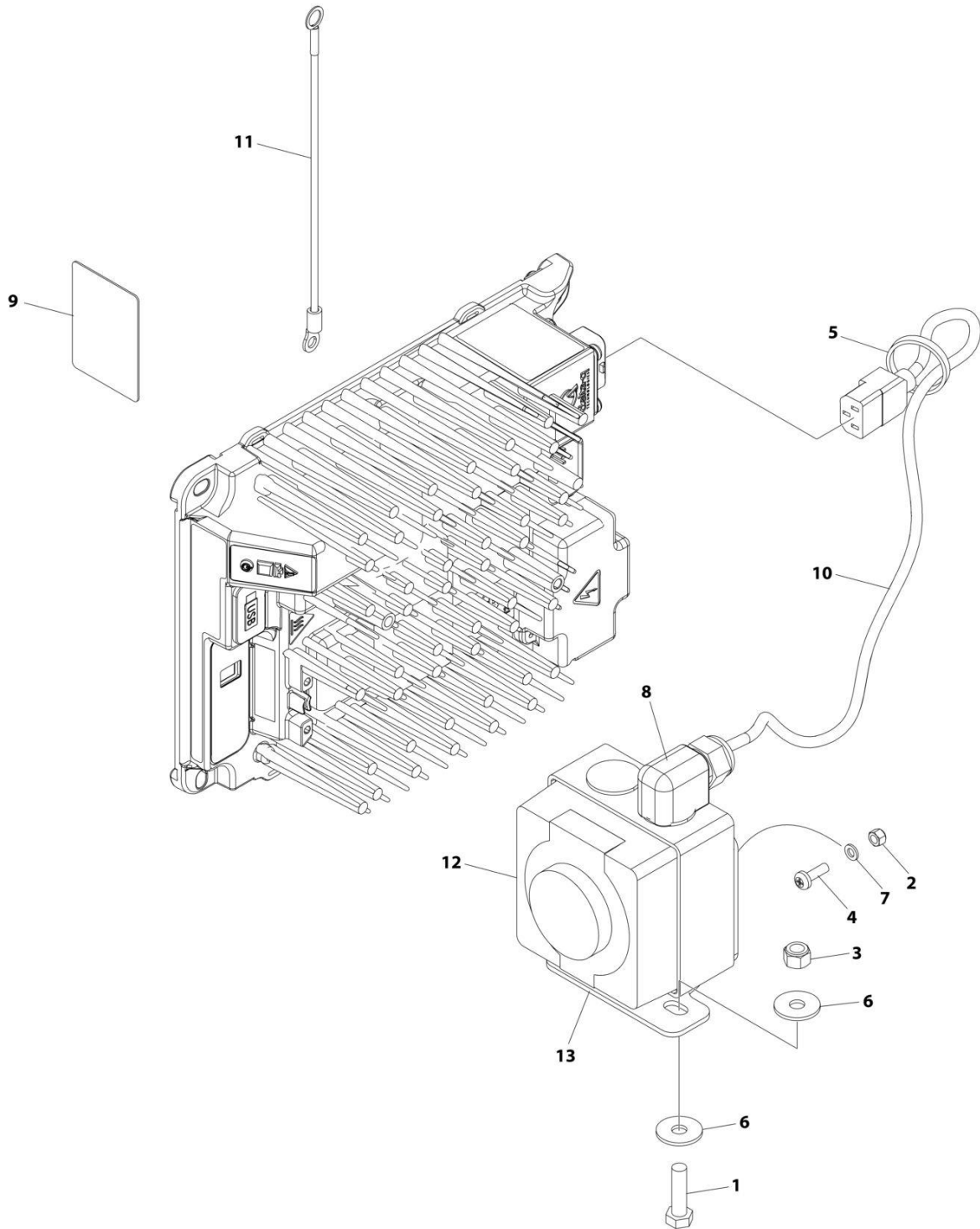

ART_1001248633

SECTION 7 - ELECTRICAL

FIGURE 7-14. CHARGER PLUG INSTALLATION (AUSTRALIAN PLUG) (R1932I/R1932)

ITEM	PART NUMBER	QTY	DESCRIPTION	REV
	1001248633	Ref	CHARGER PLUG INSTALLATION	C
1	0700814	2	Bolt M8 x 30	
2	3290505	4	Nut M5	
3	3290805	2	Nut M8	
4	3900381	4	Screw M5 x 16	
5	4240017	AR	Tie-Strap	
6	4811902	4	Washer M8	
7	4831600	4	Lockwasher M5	
8	1001103471	1	Connector, Strain Relief 90	
9	1001134280	1	Decal - Charger	
10	1001207974	1	Cable, Charger Plug (No Plug)	
11	1001227219	1	Harness, Earth/Ground	
12	1001227267	1	Inlet Socket/Box Assembly	
13	1001256503	1	Bracket	

SECTION 7 - ELECTRICAL

FIGURE 7-15. CHARGER PLUG INSTALLATION - 220V AFSINT 107 (CE & UK CA SPEC)
(R1932i/R1932)

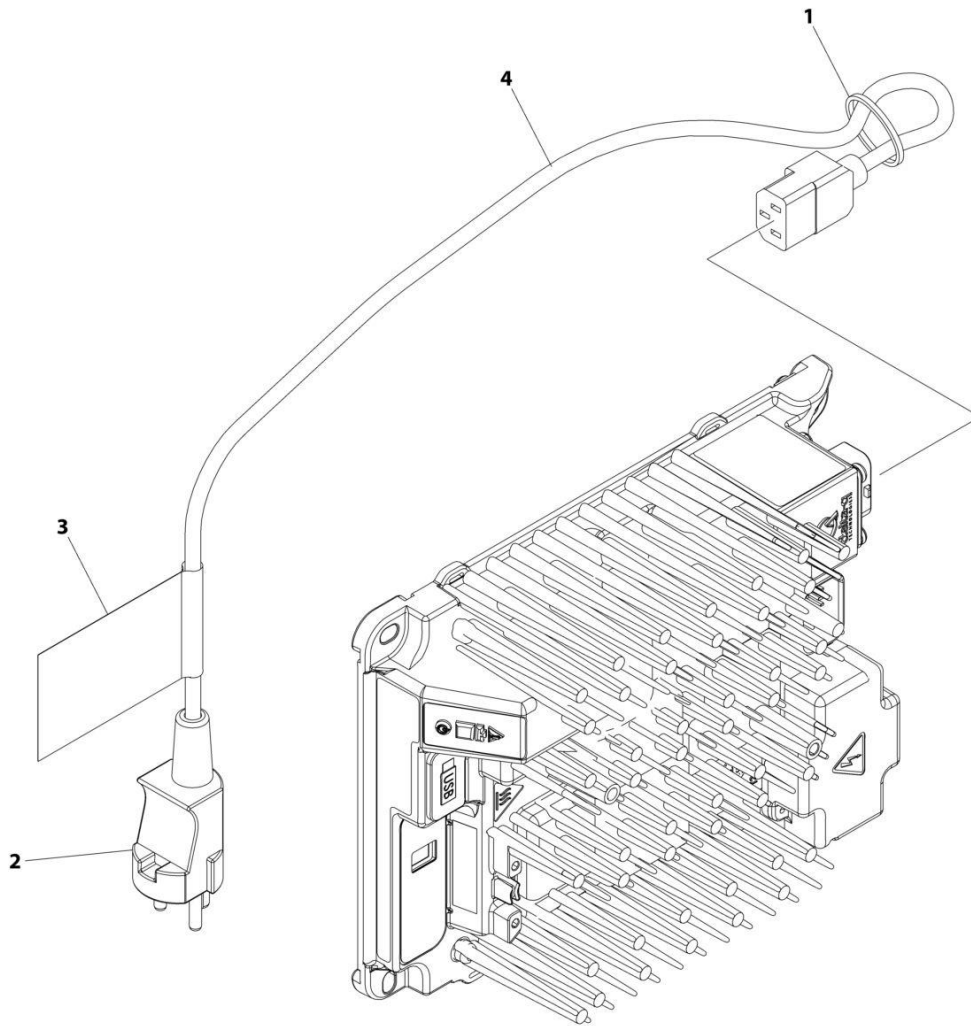

ART_1001258770

SECTION 7 - ELECTRICAL

**FIGURE 7-15. CHARGER PLUG INSTALLATION - 220V AFSINT 107 (CE & UK CA SPEC)
(R1932I/R1932)**

ITEM	PART NUMBER	QTY	DESCRIPTION	REV
	1001258770	Ref	CHARGER PLUG INSTALLATION	A
1	4240017	AR	Tie-Strap	
2	4461249	1	Terminal	
3	1001102489	1	Decal - Charger	
4	1001207974	1	Cable, Charger Plug (No Plug)	

SECTION 7 - ELECTRICAL

FIGURE 7-16. CHARGER PLUG INSTALLATION - 220V CEE7 PLUG (CE & UK CA SPECS)
(R1932i/R1932)

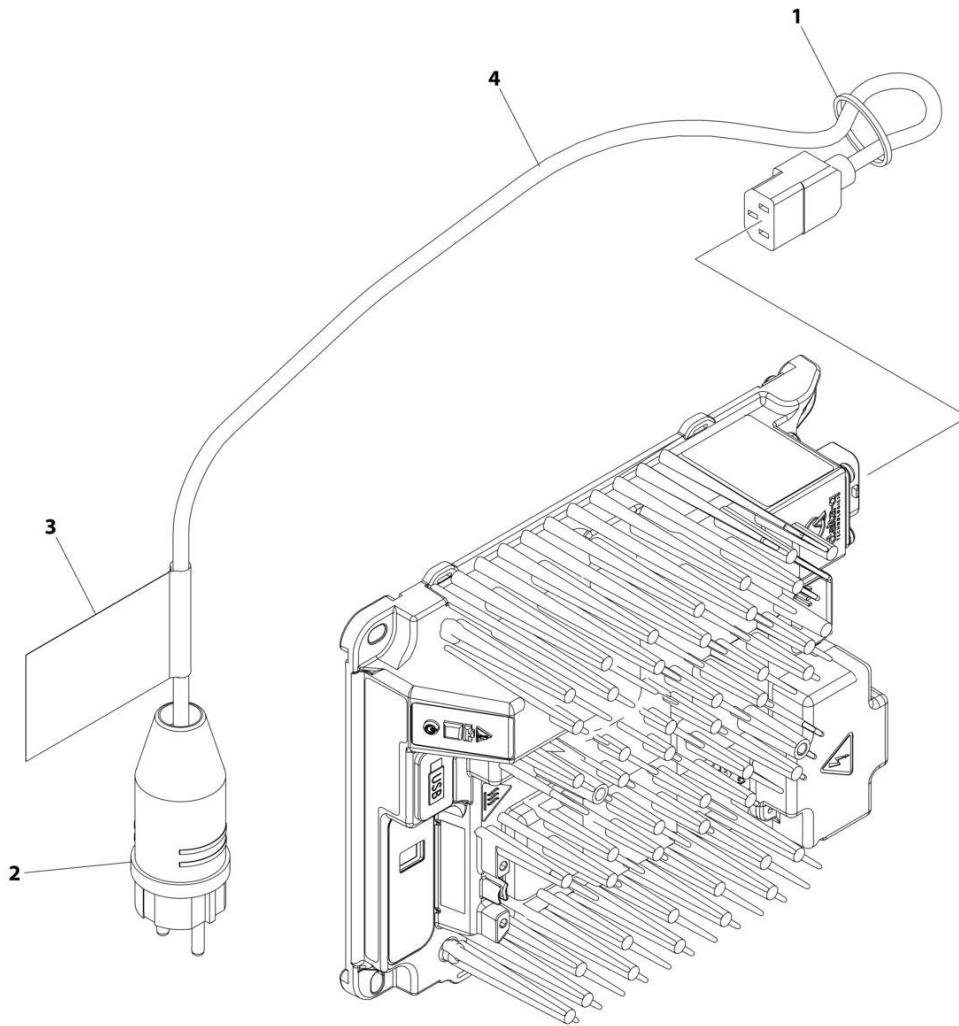

ART_1001258768

SECTION 7 - ELECTRICAL

**FIGURE 7-16. CHARGER PLUG INSTALLATION - 220V CEE7 PLUG (CE & UK CA SPECS)
(R1932I/R1932)**

ITEM	PART NUMBER	QTY	DESCRIPTION	REV
	1001258768	Ref	CHARGER PLUG INSTALLATION	A
1	4240017	AR	Tie-Strap	
2	4461205	1	Terminal	
3	1001102489	1	Decal - Charger	
4	1001207974	1	Cable, Charger Plug (No Plug)	

SECTION 7 - ELECTRICAL

FIGURE 7-17. CHARGER PLUG INSTALLATION - 110V IEC YELLOW (CE & UK CA SPEC)
(R1932i/R1932)

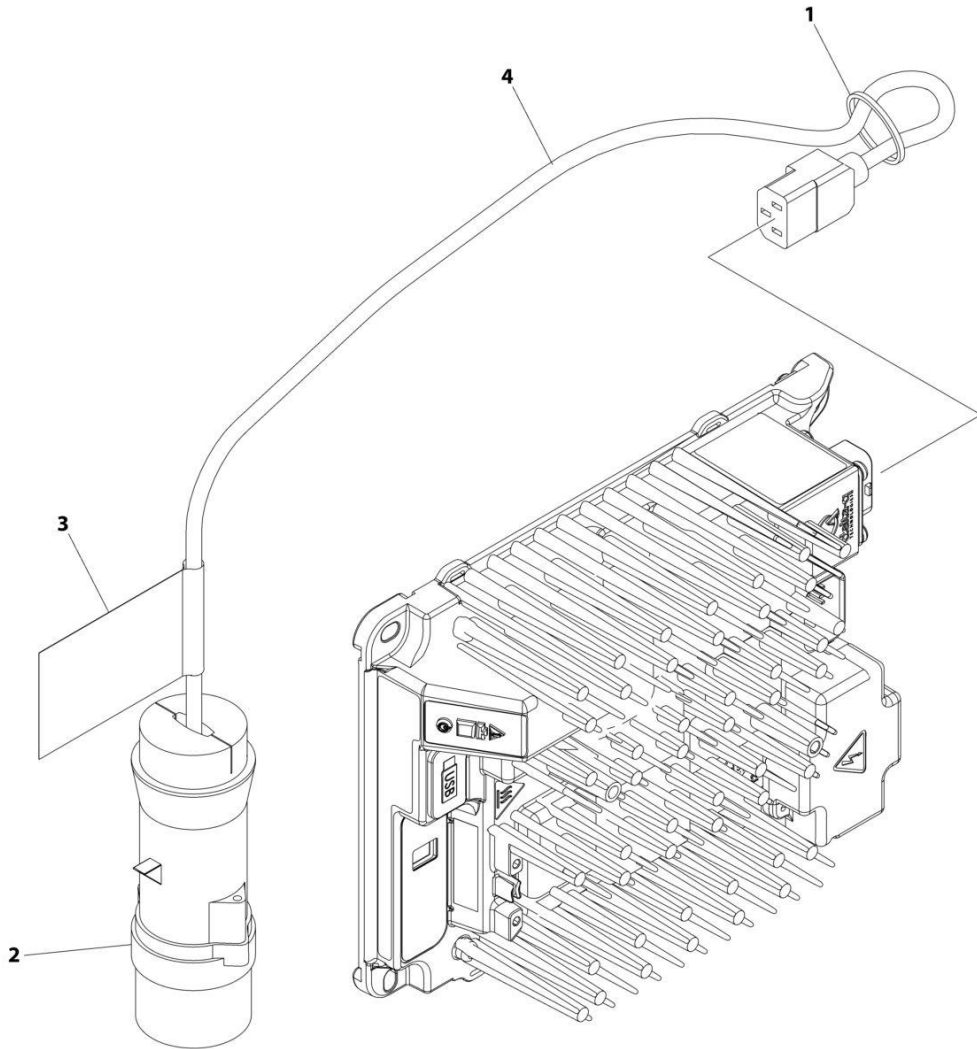

ART_1001258771

SECTION 7 - ELECTRICAL

**FIGURE 7-17. CHARGER PLUG INSTALLATION - 110V IEC YELLOW (CE & UK CA SPEC)
(R1932I/R1932)**

ITEM	PART NUMBER	QTY	DESCRIPTION	REV
	1001258771	Ref	CHARGER PLUG INSTALLATION	A
1	4240017	AR	Tie-Strap	
2	4461196	1	Terminal	
3	1001102489	1	Decal - Charger	
4	1001207974	1	Cable, Charger Plug (No Plug)	

SECTION 7 - ELECTRICAL

FIGURE 7-18. CHARGER PLUG INSTALLATION - 220V IEC BLUE (CE & UK CA SPEC)
(R1932i/R1932)

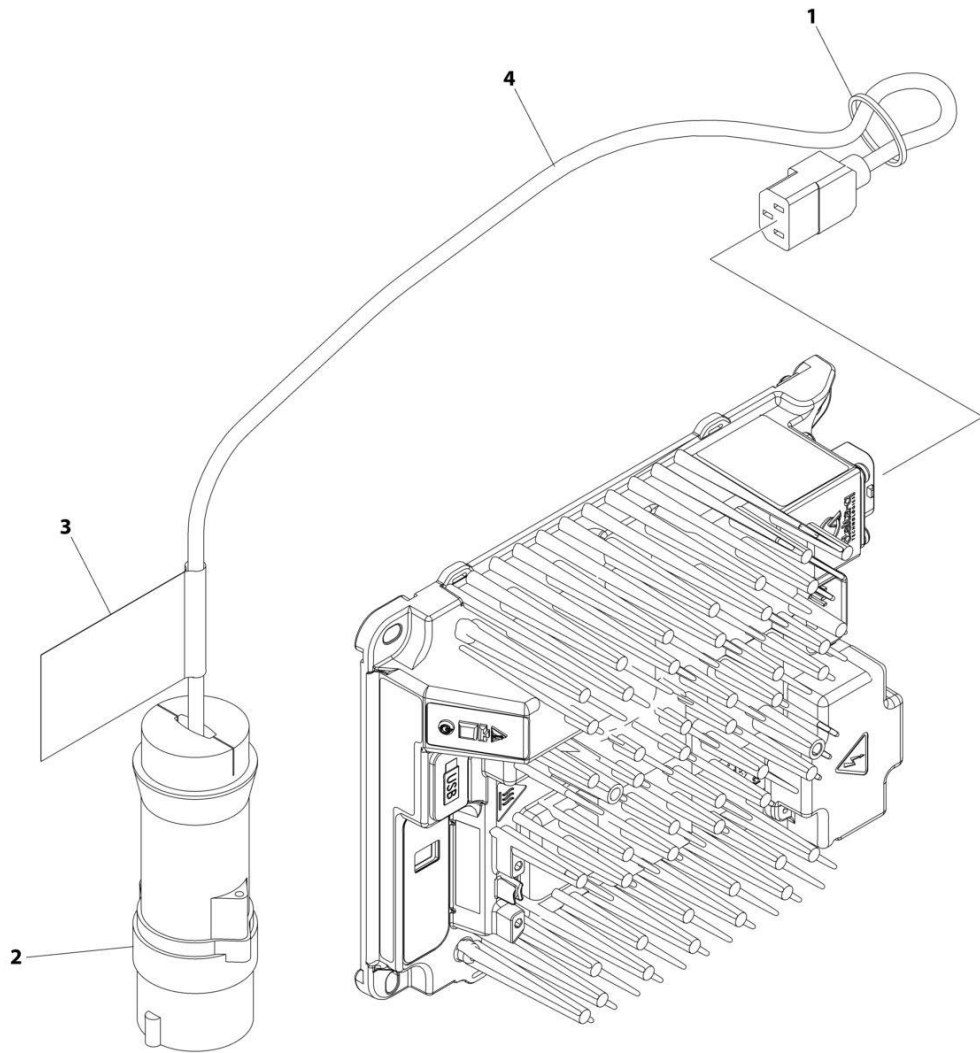

ART_1001258772

SECTION 7 - ELECTRICAL

**FIGURE 7-18. CHARGER PLUG INSTALLATION - 220V IEC BLUE (CE & UK CA SPEC)
(R1932I/R1932)**

ITEM	PART NUMBER	QTY	DESCRIPTION	REV
	1001258772	Ref	CHARGER PLUG INSTALLATION	A
1	4240017	AR	Tie-Strap	
2	4461199	1	Terminal	
3	1001102489	1	Decal - Charger	
4	1001207974	1	Cable, Charger Plug (No Plug)	

SECTION 7 - ELECTRICAL

FIGURE 7-19. CHARGER PLUG INSTALLATION (CHINA PLUG) (R1932i/R1932)

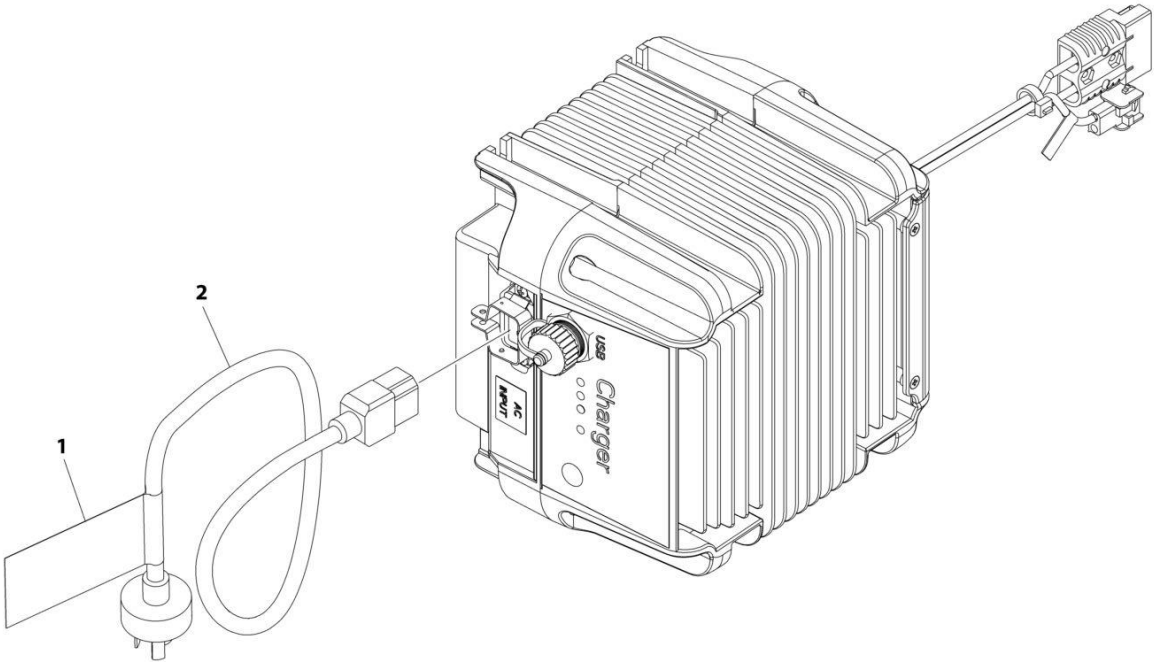

ART_1001263294

SECTION 7 - ELECTRICAL

FIGURE 7-19. CHARGER PLUG INSTALLATION (CHINA PLUG) (R1932I/R1932)

ITEM	PART NUMBER	QTY	DESCRIPTION	REV
	1001263294	Ref	CHARGER PLUG INSTALLATION	A
1	1001102489	1	Decal - Charger Label	
2	1001207973	1	Cable, Charger AC Input	

SECTION 7 - ELECTRICAL

FIGURE 7-20. CHASSIS HARNESS

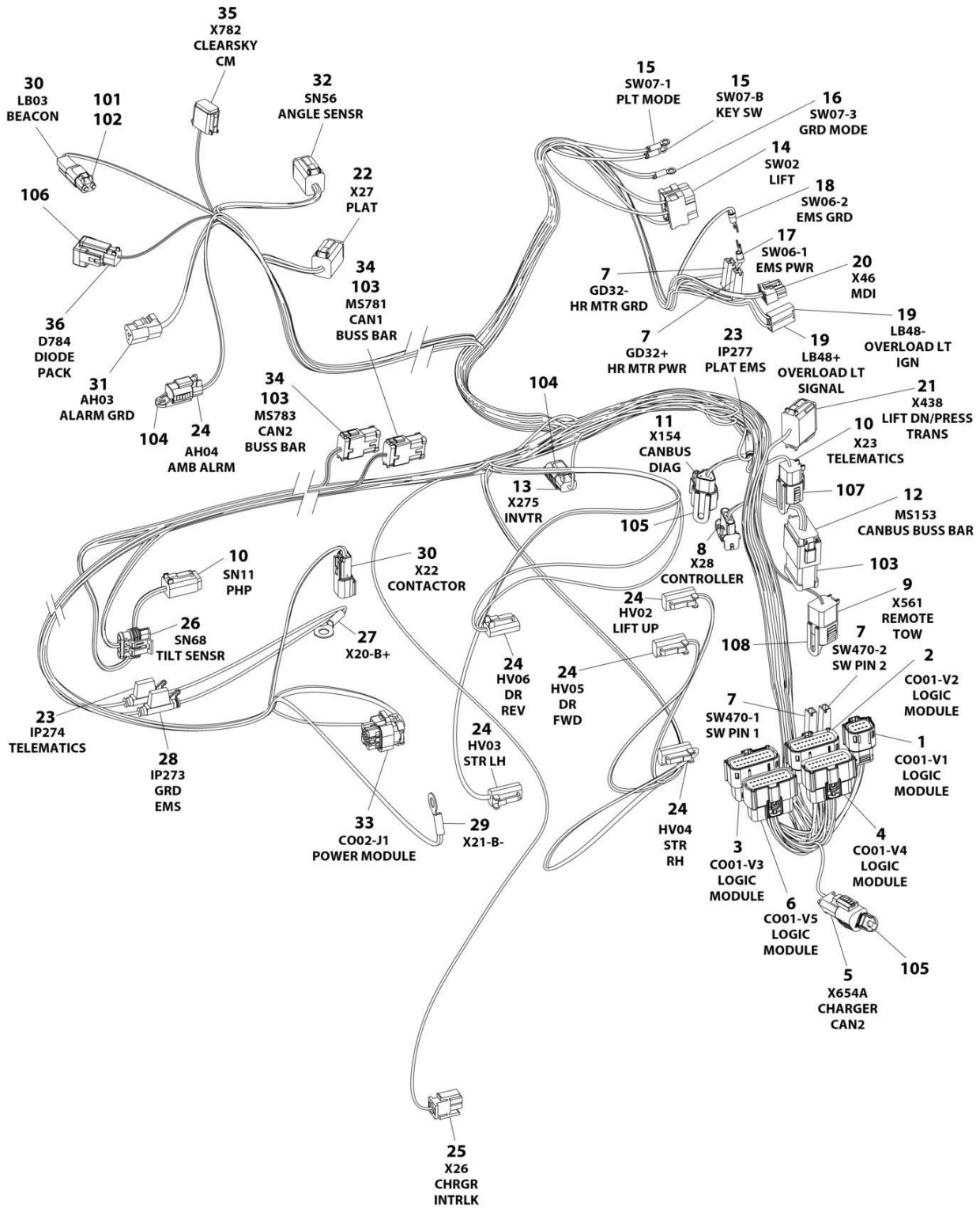

ART_1001283408

SECTION 7 - ELECTRICAL

FIGURE 7-20. CHASSIS HARNESS

ITEM	PART NUMBER	QTY	DESCRIPTION	REV
	1001283408	Ref	CHASSIS HARNESS	B
1	1001205409	1	Connector - 8 Position	
1	1001162887	8	Terminal	
2	1001205410	1	Connector - 20 Position	
2	1001162887	15	Terminal	
2	1001163340	5	Plug, Terminal	
3	1001162886	1	Connector - 20 Position	
3	1001162887	15	Terminal	
3	1001163340	5	Plug, Terminal	
4	1001205411	1	Connector - 20 Position	
4	1001162887	17	Terminal	
4	1001163340	3	Plug, Terminal	
5	4460965	1	Connector - 3 Position	
5	4460944	2	Socket, Female	
5	4460466	1	Plug, Terminal	
6	1001205412	1	Connector - 20 Position	
6	1001162887	19	Terminal	
6	1001163340	1	Plug, Terminal	
7	4460260	4	Cover, Terminal	
7	4460259	4	Terminal	
8	4460761	1	Plug, Male - 4 Position	
8	4460227	4	Socket, Female	
9	4460894	1	Plug, Male - 6 Position	
9	4460465	4	Socket, Female	
9	4460466	2	Plug, Terminal	
10	4460884	2	Plug, Male - 4 Position	
10	4460465	8	Socket, Female	
11	1001116812	1	Receptacle, Female - 3 Position	
11	4460944	2	Pin, Male	
11	4460466	1	Plug, Terminal	
12	4460933	1	Plug, Male - 12 Position	
12	4460944	12	Socket, Female	
12	4460466	2	Plug	
13	4460891	1	Plug, Male - 2 Position	
13	4460465	1	Socket, Female	
13	4460466	1	Plug, Terminal	
14	4460418	1	Connector - 6 Position	
14	1001159186	3	Terminal	
15	4460247	2	Terminal, Ring	
16	4460042	1	Terminal, Ring	
17	4460183	1	Terminal, Ring	
18	4460115	1	Terminal, Ring	
19	1001117000	2	Cover, Terminal	
20	1001151629	1	Plug, Male - 8 Position	
20	4461023	2	Terminal	
20	4460877	2	Terminal	
21	4460933	1	Plug, Male - 12 Position	
21	4460944	10	Socket, Female	
21	4460466	2	Plug, Terminal	
22	4460894	1	Plug, Male - 6 Position	

SECTION 7 - ELECTRICAL

ITEM	PART NUMBER	QTY	DESCRIPTION	REV
22	4460465	4	Socket, Female	
22	4460944	2	Socket, Female	
23	2400060	2	Holder/Cover, Fuse	
23	8229242	2	Fuse 5 Amp	
24	4460891	6	Plug, Male - 2 Position	
24	4460465	12	Socket, Female	
25	4460320	1	Plug, Male - 2 Position	
25	4460226	1	Socket, Female	
26	1001103012	1	Plug, Male - 4 Position	
26	1001237212	4	Socket, Female	
26	1001197457	4	Seal, Terminal	
27	8220045	1	Terminal, Ring	
28	2400060	1	Holder/Cover, Fuse	
28	8229244	1	Fuse 15 Amp	
29	4460019	1	Terminal, Ring	
30	4460897	2	Receptacle, Female - 2 Position	
30	4460464	4	Pin, Male	
31	4460539	1	Plug, Male - 3 Position	
31	4460465	3	Socket, Female	
32	4460894	1	Plug, Male - 6 Position	
32	4460465	6	Socket, Female	
33	1001113961	1	Connector - 8 Position	
33	4460871	4	Socket, Female	
33	4460905	4	Plug, Terminal	
34	4460933	2	Connector	
34	4460944	16	Socket	
34	4460466	8	Plug	
35	4460930	1	Connector	
35	4460465	1	Socket	
36	4460930	1	Connector	
36	4460465	8	Socket	
101	4460466	2	Plug, Terminal	
102	4460891	1	Plug, Male - 2 Position	
103	1001125677	3	Receptacle, Female Buss Bar - 2x6 Position	
104	1001144295	2	Cap - 2 Position	
105	1001144296	2	Cap - 3 Position	
106	1001152266	1	Cap	
107	1001192401	1	Cap, Dust	
108	1001213448	1	Cap - 6 Position	

SECTION 7 - ELECTRICAL

FIGURE 7-21. CLEARSKY INSTALLATION - 3 WIRE (ALL SPECS)

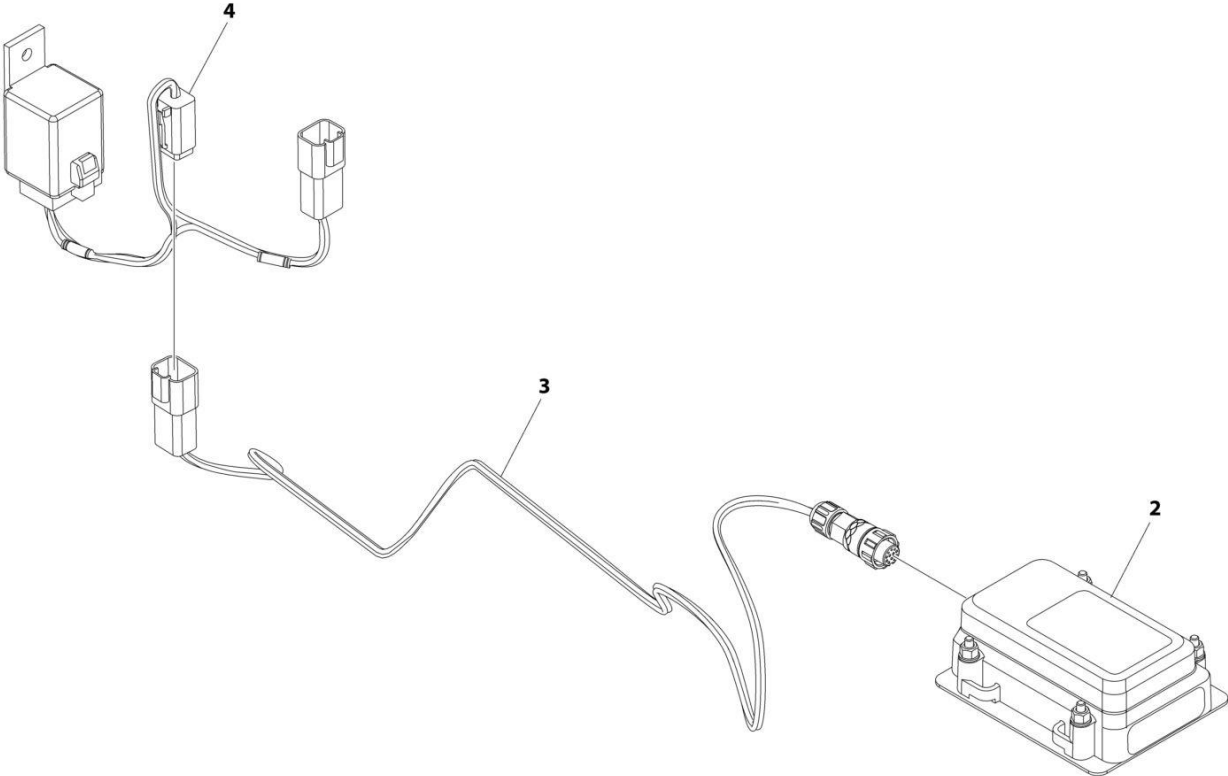

ART_1001278847

SECTION 7 - ELECTRICAL

FIGURE 7-21. CLEARSKY INSTALLATION - 3 WIRE (ALL SPECS)

ITEM	PART NUMBER	QTY	DESCRIPTION	REV
	1001278847	Ref	CLEARSKY INSTALLATION	A
1	4240032	AR	Tie-strap (Not Shown)	
2	1001272659	1	Module, ClearSky	
3	1001273012	1	Harness, ClearSky (See Separate Breakdown in this Section)	
4	1001278513	1	Harness, ClearSky Jumper (See Separate Breakdown in this Section)	

SECTION 7 - ELECTRICAL

FIGURE 7-22. CLEARSKY INSTALLATION (ANSI & CSA SPECS)

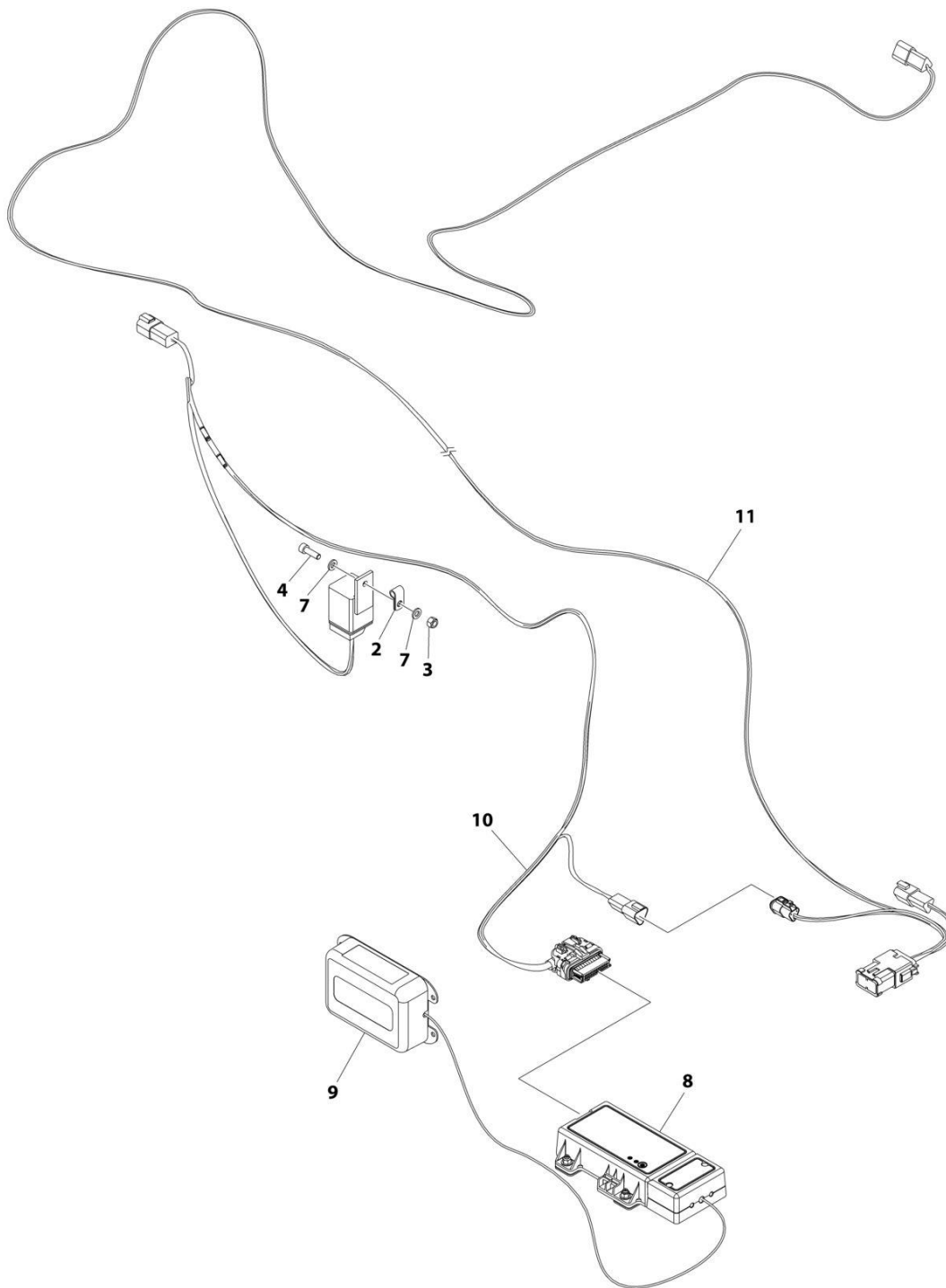

ART_1001251144

SECTION 7 - ELECTRICAL

FIGURE 7-22. CLEARSKY INSTALLATION (ANSI & CSA SPECS)

ITEM	PART NUMBER	QTY	DESCRIPTION	REV
	1001251144	Ref	CLEARSKY INSTALLATION	E
1	1062255	AR	Tie-strap (365mm) (Not Shown)	
2	1320136	1	Clamp	
3	3290605	1	Nut, Lock M6	
4	4031708	1	Capscrew M6 x 20	
5	4240032	AR	Tie-strap (3-5/8in to 4in) (Not Shown)	
6	4460234	AR	Mount, Tie-strap (Not Shown)	
7	4811700	2	Washer M6	
8	1001262322	1	Module, ClearSky	
9	1001262327	1	Antenna, ClearSky	
10	1001254026	1	Harness, ClearSky (See Separate Breakdown in this Section)	
11	1001254027	1	Harness, ClearSky Splice (See Separate Breakdown in this Section)	

SECTION 7 - ELECTRICAL

FIGURE 7-23. CLEARSKY INSTALLATION (ANSI EXPORT, CE & UK CA SPECS)

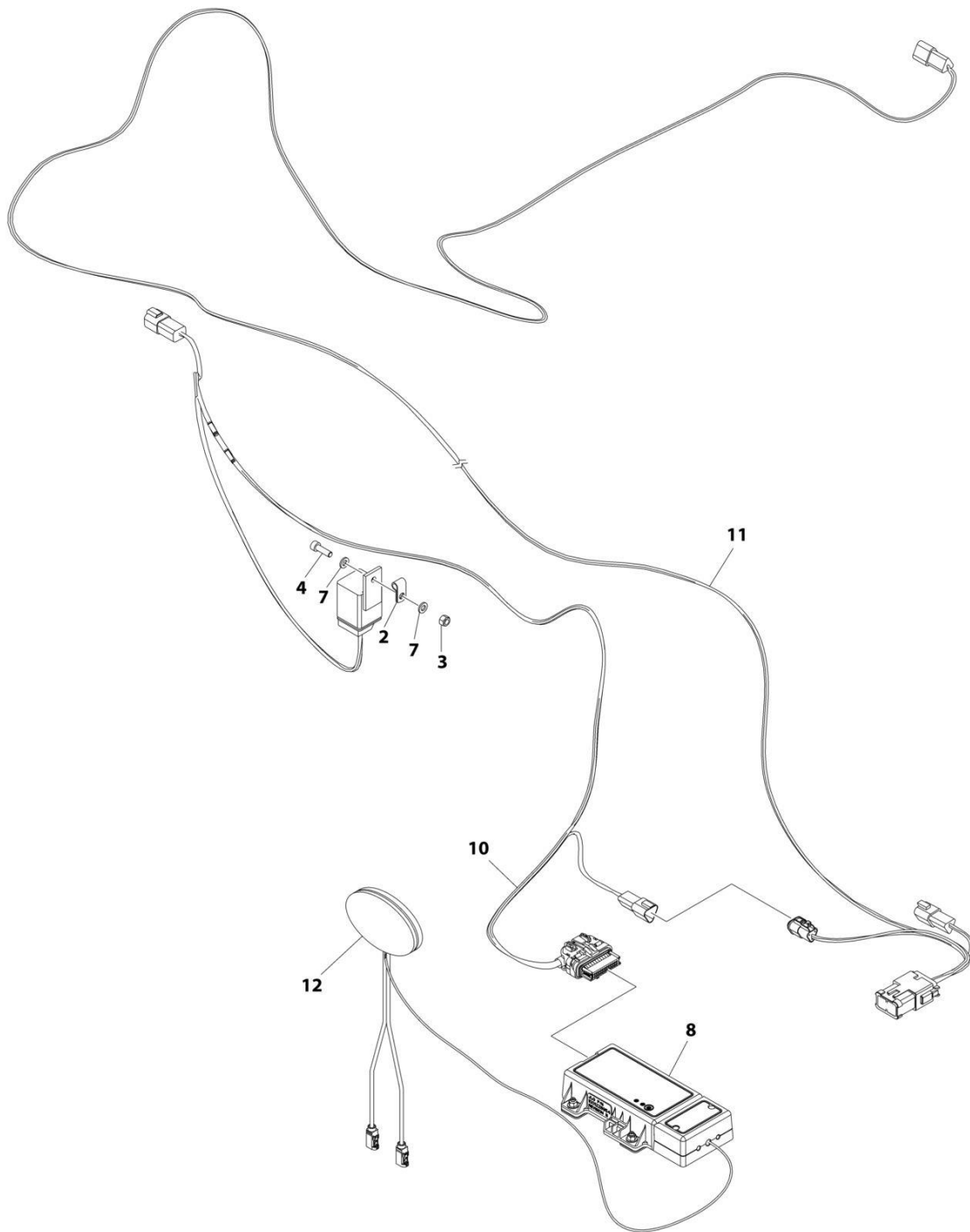

ART_1001251145

SECTION 7 - ELECTRICAL

FIGURE 7-23. CLEARSKY INSTALLATION (ANSI EXPORT, CE & UK CA SPECS)

ITEM	PART NUMBER	QTY	DESCRIPTION	REV
	1001251145	Ref	CLEARSKY INSTALLATION	C
1	1062255	AR	Tie-strap (365mm) (Not Shown)	
2	1320136	1	Clamp	
3	3290605	1	Nut, Lock M6	
4	4031708	1	Capscrew M6 x 20	
5	4240032	AR	Tie-strap (3-5/8in to 4in) (Not Shown)	
6	4460234	AR	Mount, Tie-strap (Not Shown)	
7	4811700	2	Washer M6	
8	1001228954	1	Module, ClearSky	
10	1001254026	1	Harness, ClearSky (See Separate Breakdown in this Section)	
11	1001254027	1	Harness, ClearSky Splice (See Separate Breakdown in this Section)	
12	1001236144	1	Antenna, ClearSky	

SECTION 7 - ELECTRICAL

FIGURE 7-24. CLEARSKY INSTALLATION (AUSTRALIAN SPECS)

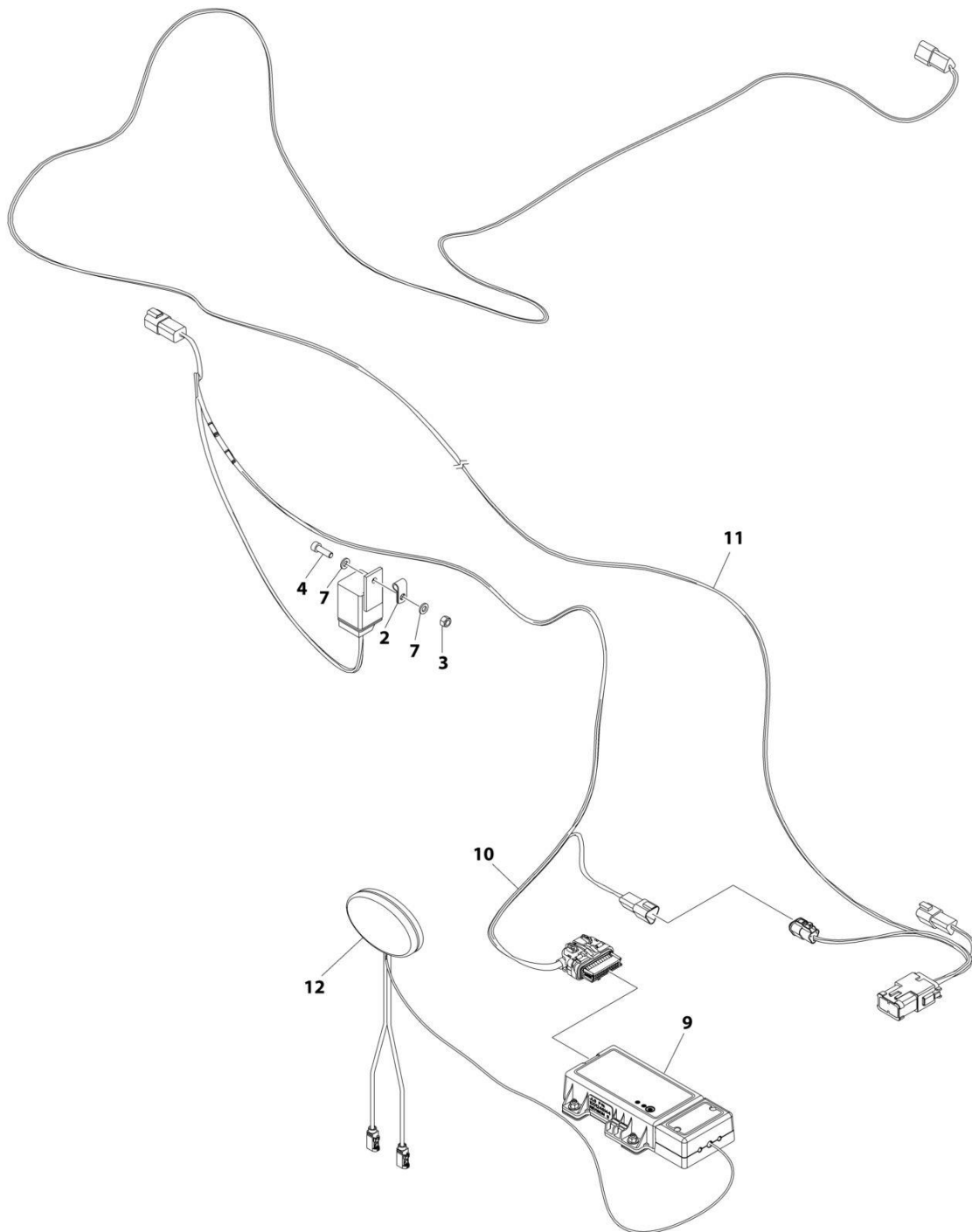

ART_1001251146

SECTION 7 - ELECTRICAL

FIGURE 7-24. CLEARSKY INSTALLATION (AUSTRALIAN SPECS)

ITEM	PART NUMBER	QTY	DESCRIPTION	REV
	1001251146	Ref	CLEARSKY INSTALLATION	D
1	1062255	AR	Tie-strap (365mm) (Not Shown)	
2	1320136	1	Clamp	
3	3290605	1	Nut, Lock M6	
4	4031708	1	Capscrew M6 x 20	
5	4240032	AR	Tie-strap (3-5/8in to 4in) (Not Shown)	
6	4460234	AR	Mount, Tie-strap (Not Shown)	
7	4811700	2	Washer M6	
9	1001246144	1	Module, ClearSky	
10	1001254026	1	Harness, ClearSky (See Separate Breakdown in this Section)	
11	1001254027	1	Harness, ClearSky Splice (See Separate Breakdown in this Section)	
12	1001236144	1	Antenna, ClearSky	

SECTION 7 - ELECTRICAL

FIGURE 7-25. CLEARSKY INSTALLATION (CHINA SPECS)

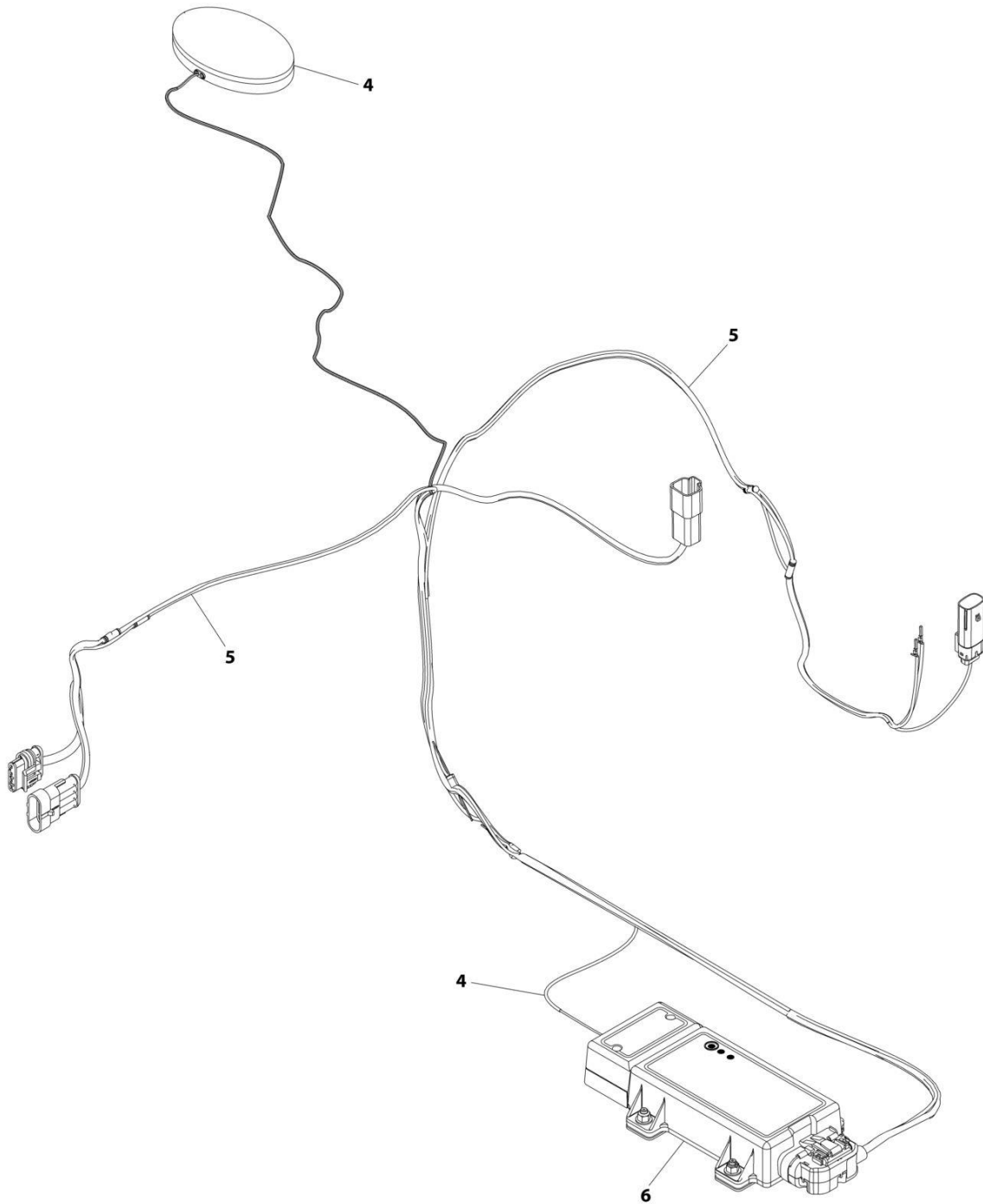

ART_1001246531

SECTION 7 - ELECTRICAL

FIGURE 7-25. CLEARSKY INSTALLATION (CHINA SPECS)

ITEM	PART NUMBER	QTY	DESCRIPTION	REV
	1001246531	Ref	CLEARSKY INSTALLATION	A
1	1062255	AR	Tie-strap (365mm) (Not Shown)	
2	4240032	AR	Tie-strap (3-5/8in to 4in) (Not Shown)	
3	4460234	AR	Mount, Tie-strap (Not Shown)	
4	1001236144	1	Antenna, ClearSky	
5	1001238845	1	Harness, ClearSky (See Separate Breakdown in this Section)	
6	1001246145	1	Module, ClearSky	

SECTION 7 - ELECTRICAL

FIGURE 7-26. CLEARSKY HARNESS - 3 WIRE (ALL SPECS)

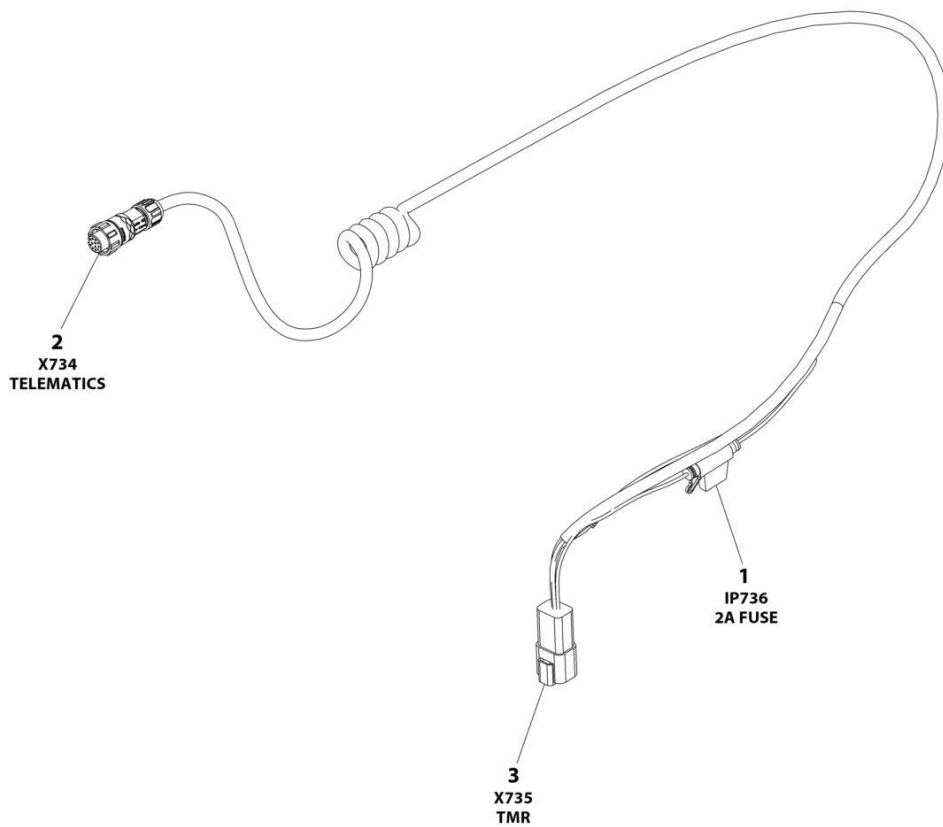

ART_1001273012

SECTION 7 - ELECTRICAL

FIGURE 7-26. CLEARSKY HARNESS - 3 WIRE (ALL SPECS)

ITEM	PART NUMBER	QTY	DESCRIPTION	REV
	1001273012	Ref	CLEARSKY TELEMATICS HARNESS - GT1030	D
1	1001255901	1	Fuseholder	
1	1001196634	1	Fuse - 2Amp	
2	1001272997	1	Connector - 12 Position	
2		Ref	Terminal	
3	4460932	1	Receptacle, Female - 4 Position	
3	4460464	4	Pin, Male	

SECTION 7 - ELECTRICAL

FIGURE 7-27. CLEARSKY JUMPER HARNESS - 3 WIRE (ALL SPECS)

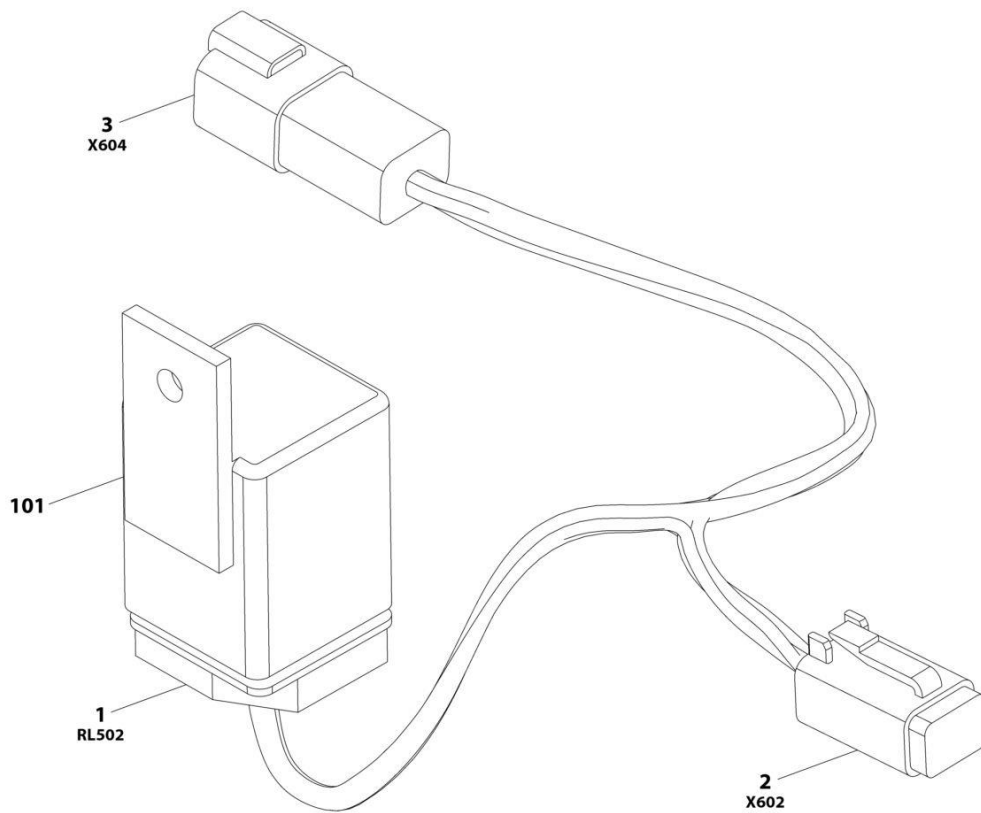

ART_1001278513

SECTION 7 - ELECTRICAL

FIGURE 7-27. CLEARSKY JUMPER HARNESS - 3 WIRE (ALL SPECS)

ITEM	PART NUMBER	QTY	DESCRIPTION	REV
	1001278513	Ref	CLEARSKY JUMPER HARNESS	A
1	1001117057	1	Connector - 4 Position	
1	1001116732	4	Terminal	
2	4460884	1	Connector - 4 Position	
2	4460465	4	Terminal	
3	4460932	1	Connector - 4 Position	
3	4460464	4	Terminal	
101	1001097347	1	Relay	

SECTION 7 - ELECTRICAL

FIGURE 7-28. CLEARSKY HARNESS (ALL SPECS EXCEPT CHINA SPECS)

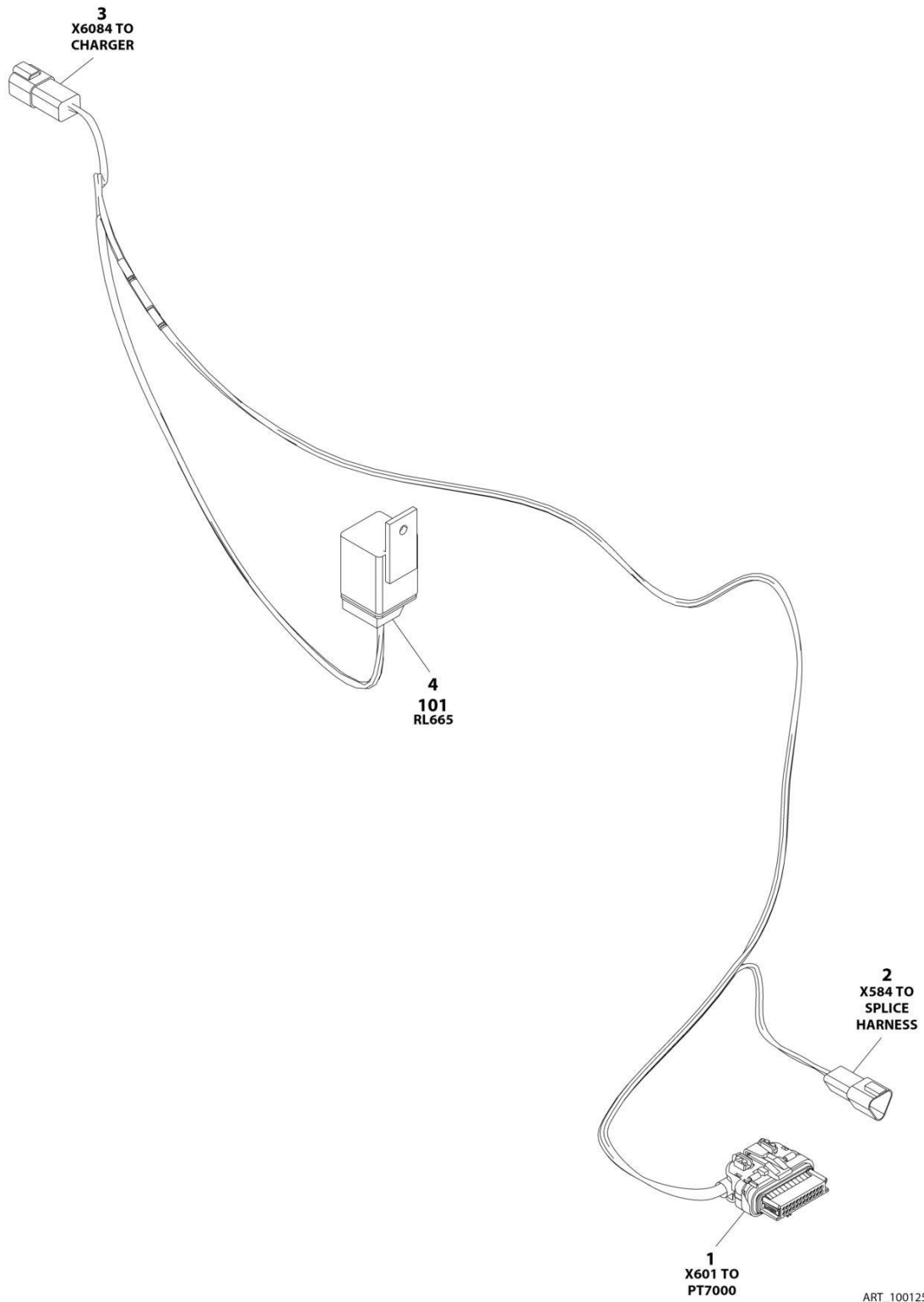

SECTION 7 - ELECTRICAL

FIGURE 7-28. CLEARSKY HARNESS (ALL SPECS EXCEPT CHINA SPECS)

ITEM	PART NUMBER	QTY	DESCRIPTION	REV
	1001254026	Ref	CLEARSKY HARNESS	B
1	1001226636	1	Connector	
1	1001226637	5	Socket	
1	1001116731	19	Plug	
2	1001144147	1	Connector	
2	4460943	2	Pin	
2	4460466	1	Plug	
3	4460932	1	Connector	
3	4460464	3	Pin	
3	4460466	1	Plug	
4	1001117057	1	Connector	
4	1001116732	4	Socket	
101	1001097347	1	Relay	

SECTION 7 - ELECTRICAL

FIGURE 7-29. CLEARSKY HARNESS (CHINA SPECS)

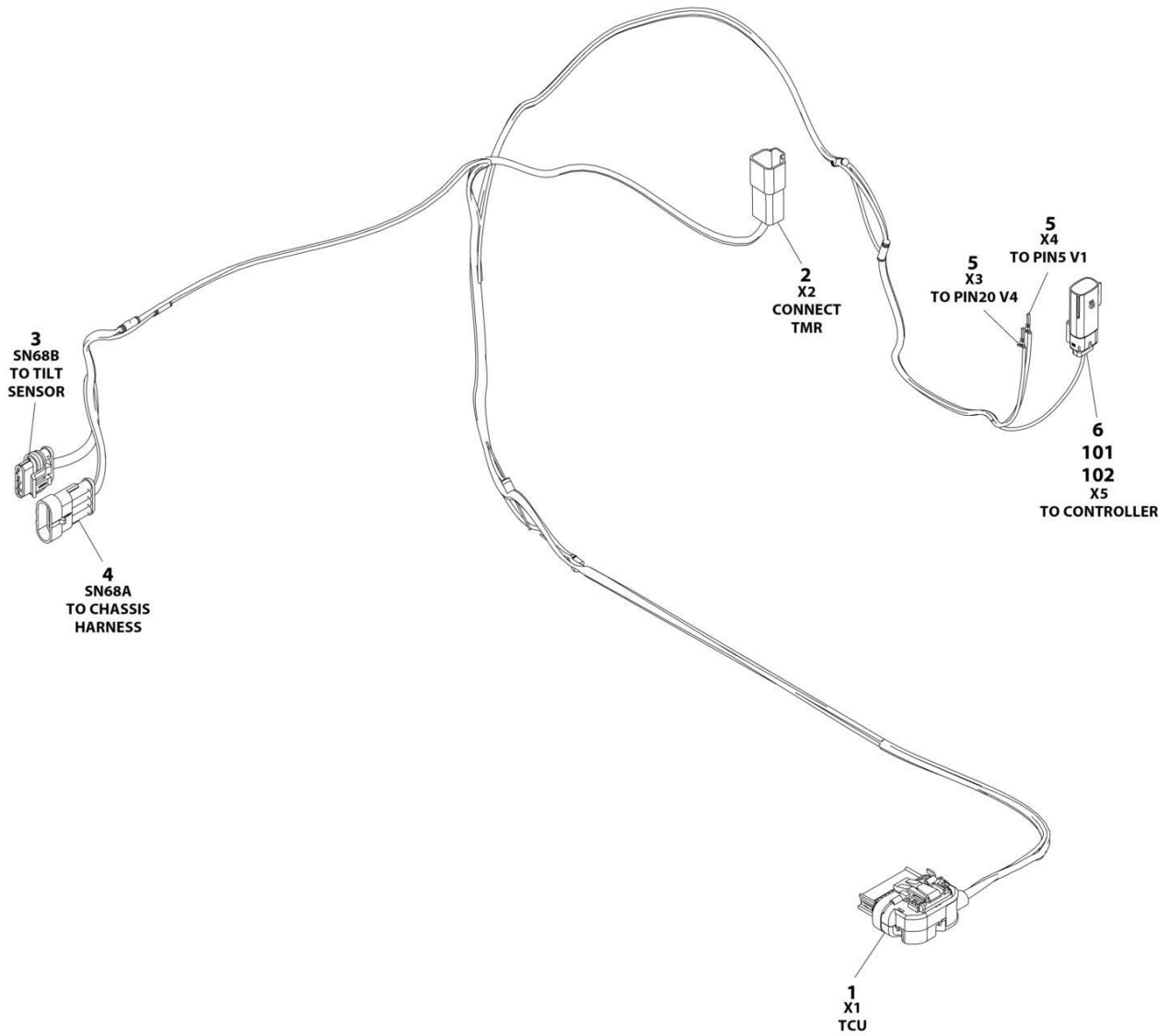

ART_1001238845

SECTION 7 - ELECTRICAL

FIGURE 7-29. CLEARSKY HARNESS (CHINA SPECS)

ITEM	PART NUMBER	QTY	DESCRIPTION	REV
	1001238845	Ref	CLEARSKY HARNESS	C
1	1001226636	1	Connector	
1	1001226637	3	Socket - for 18AWG Wire	
1	1001237211	2	Socket - for 20AWG Wire	
1	1001116731	19	Plug	
2	4460932	1	Connector	
2	4460464	2	Pin	
2	4460466	2	Plug	
3	1001103012	1	Connector	
3	1001237212	4	Pin	
3	1001104498	4	Seal	
4	1001103013	1	Connector	
4	1001237213	4	Pin	
4	1001104498	4	Seal	
5	1001162887	2	Terminal	
6	1001238955	1	Connector	
6	1001238762	2	Pin	
6	1001163340	1	Plug	
101	1001163340	1	Plug	
102	1001238956	1	Connector	

SECTION 7 - ELECTRICAL

FIGURE 7-30. CLEARSKY SPLICE HARNESS

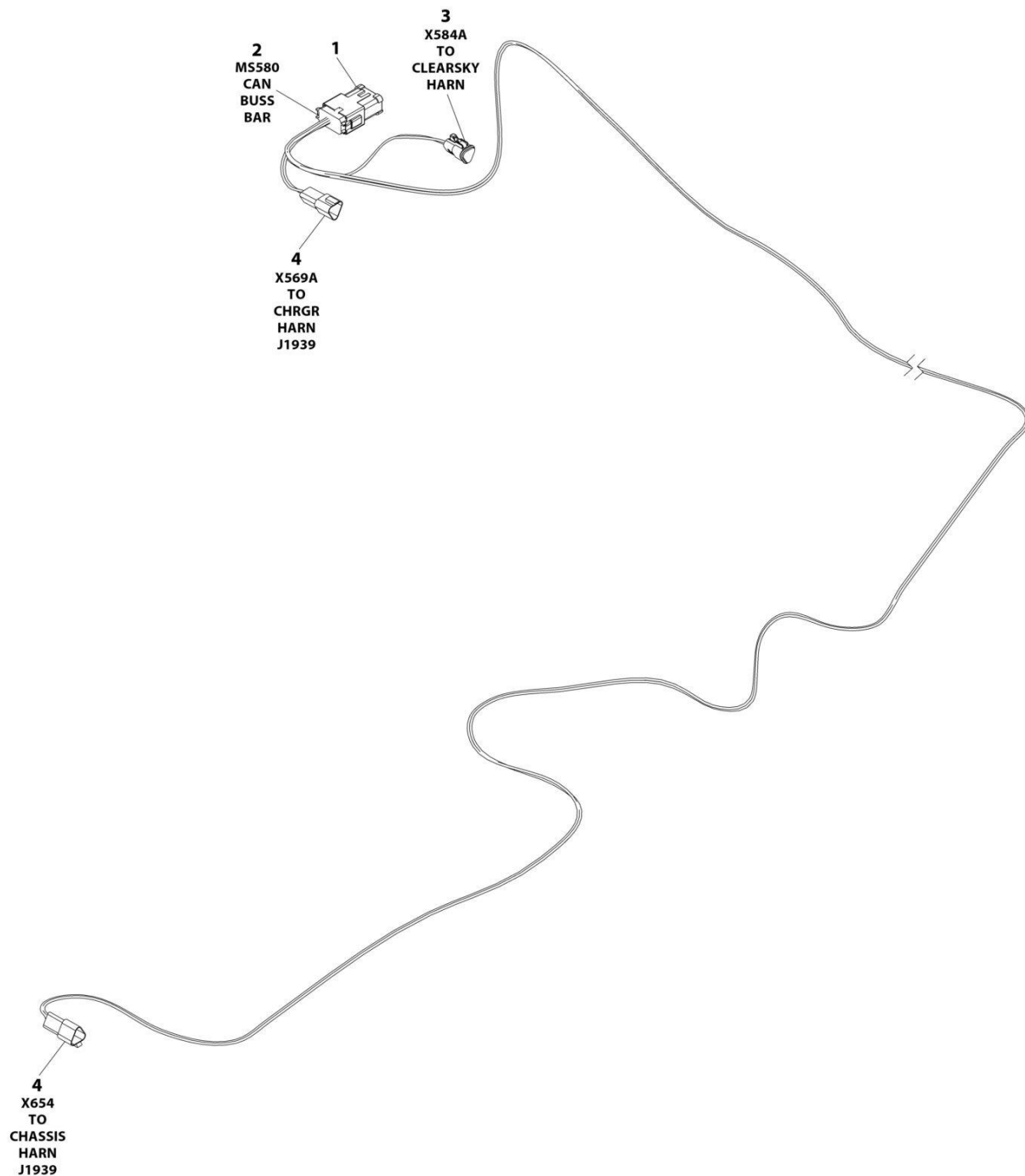

ART_1001254027

SECTION 7 - ELECTRICAL

FIGURE 7-30. CLEARSKY SPLICE HARNESS

ITEM	PART NUMBER	QTY	DESCRIPTION	REV
	1001254027	Ref	CAN SPLICE HARNESS	A
1	1001125677	1	Connector, Bus Bar - 12 Position	
2	4460933	1	Plug, Male - 12 Position	
2	4460944	6	Socket, Female	
2	4460466	6	Plug, Terminal	
3	1001118812	1	Plug, Male - 3 Position	
3	4460944	2	Socket, Female	
3	4460466	1	Plug, Terminal	
4	1001144147	2	Receptacle, Female - 3 Position	
4	4460943	4	Pin, Male	
4	4460466	2	Plug, Terminal	

SECTION 7 - ELECTRICAL

FIGURE 7-31. GROUND TO PLATFORM CABLE INSTALLATION - R1532I WITHOUT PLATFORM COIL CABLE

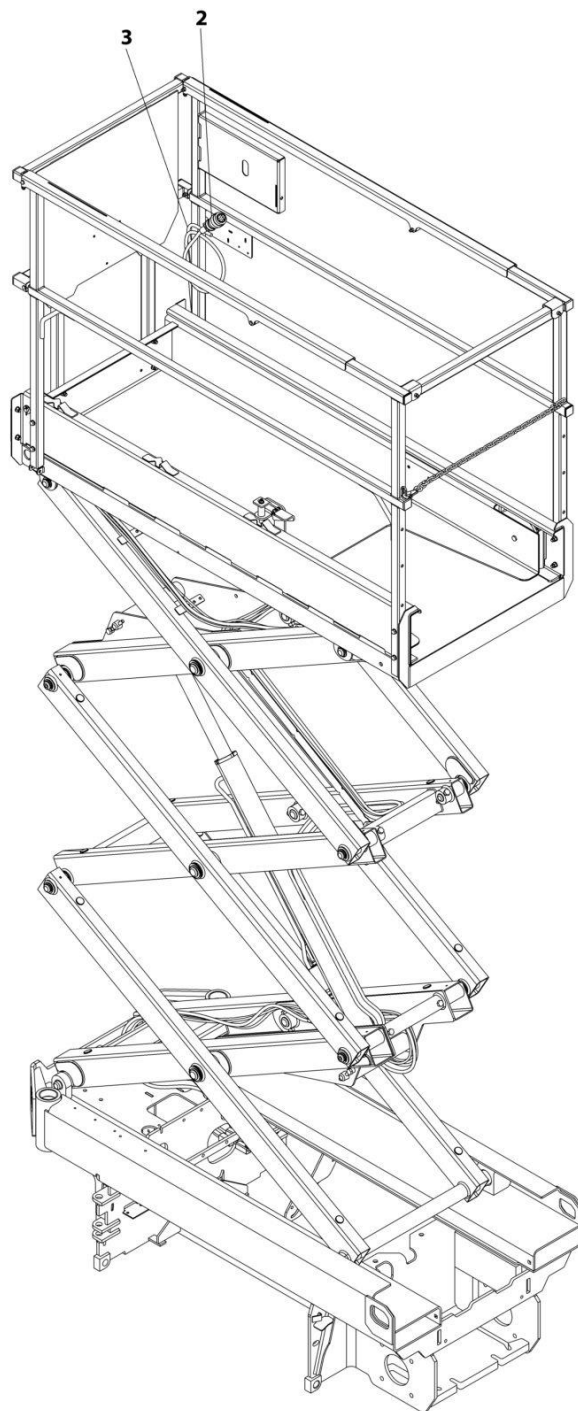

ART_1001225490

SECTION 7 - ELECTRICAL

FIGURE 7-31. GROUND TO PLATFORM CABLE INSTALLATION - R1532I WITHOUT PLATFORM COIL CABLE

ITEM	PART NUMBER	QTY	DESCRIPTION	REV
	1001225490	Ref	GROUND TO PLATFORM CABLE INSTALLATION	A
1	4240017	AR	Tie-Strap (Not Shown)	
2	1001200812	1	Platform Harness	
2	4460899	1	Receptacle, Female - 6 Position (To Item 3)	
2	4460464	4	Pin, Male	
2	4460943	2	Pin, Male	
2	4460754	1	Connector - 14 Position (To Console Box)	
2	4460465	8	Socket, Female	
2	4460466	6	Plug, Terminal	
3	1001225377	1	Cable Assembly - Ground to Platform	
3	4460894	1	Plug, Male - 6 Position (To Platform Harness Item 2)	
3	4460465	4	Socket, Female	
3	4460944	2	Socket, Female	
3	4460899	1	Receptacle, Female - 6 Position (To Chassis Harness)	
3	4460464	4	Pin, Male	
3	4460943	2	Pin, Male	

SECTION 7 - ELECTRICAL

FIGURE 7-32. GROUND TO PLATFORM CABLE INSTALLATION - R1532i WITH PLATFORM COIL CABLE

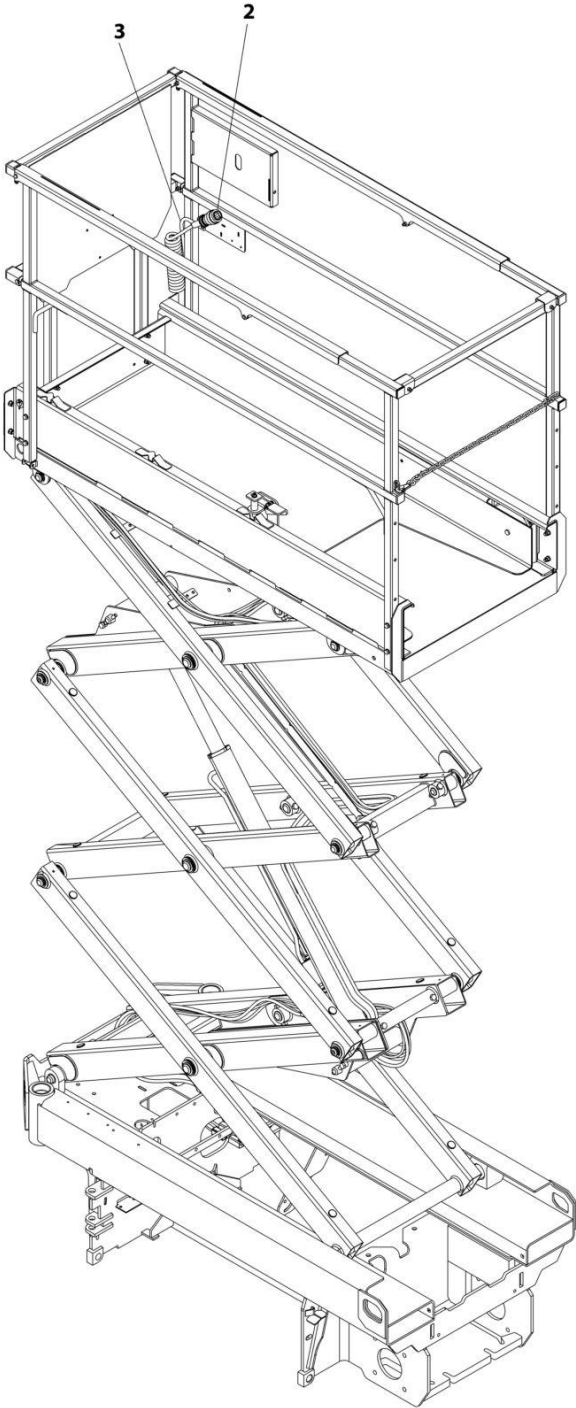

ART_1001225491

SECTION 7 - ELECTRICAL

FIGURE 7-32. GROUND TO PLATFORM CABLE INSTALLATION - R1532I WITH PLATFORM COIL CABLE

ITEM	PART NUMBER	QTY	DESCRIPTION	REV
	1001225491	Ref	GROUND TO PLATFORM CABLE INSTALLATION	A
1	4240017	AR	Tie-Strap (Not Shown)	
2	1001202184	1	Platform Harness	
2	4460899	1	Receptacle, Female - 6 Position (To Item 3)	
2	4460464	4	Pin, Male	
2	4460943	2	Pin, Male	
2	4460754	1	Connector - 14 Position (To Console Box)	
2	4460465	8	Socket, Female	
2	4460466	6	Plug, Terminal	
3	1001225377	1	Cable Assembly - Ground to Platform	
3	4460894	1	Plug, Male - 6 Position (To Platform Harness Item 2)	
3	4460465	4	Socket, Female	
3	4460944	2	Socket, Female	
3	4460899	1	Receptacle, Female - 6 Position (To Chassis Harness)	
3	4460464	4	Pin, Male	
3	4460943	2	Pin, Male	

SECTION 7 - ELECTRICAL

FIGURE 7-33. GROUND TO PLATFORM CABLE INSTALLATION - R1532I WITHOUT PLATFORM COIL CABLE AND WITH FOOTSWITCH

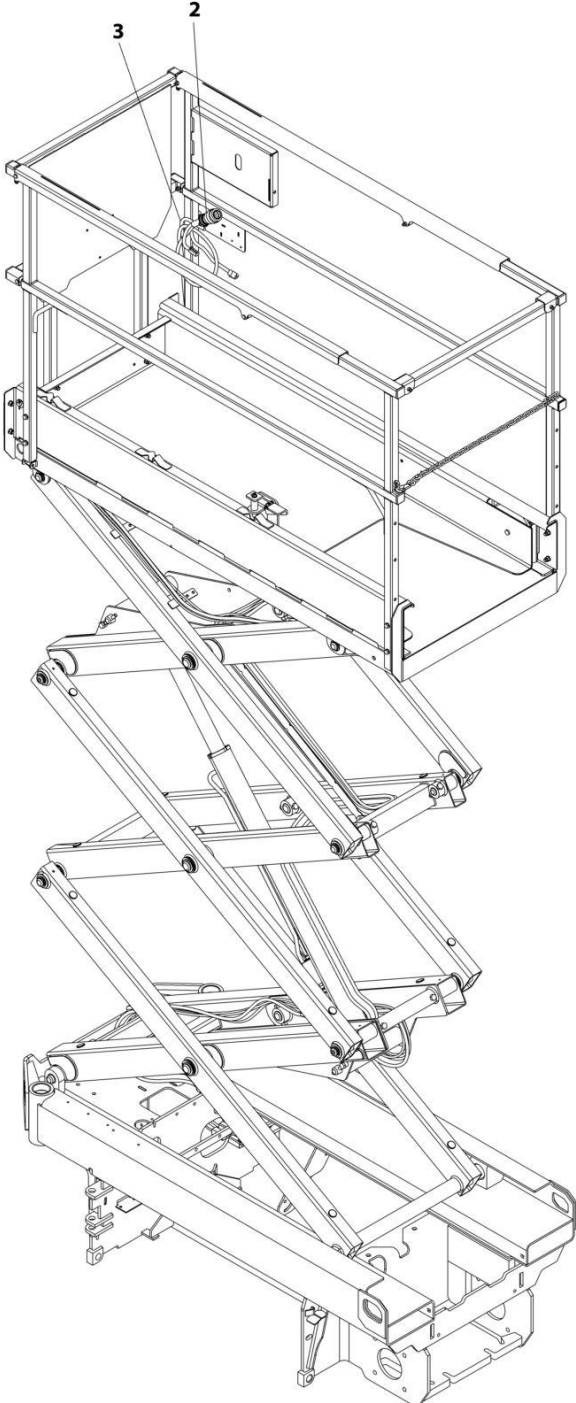

ART_1001225492

SECTION 7 - ELECTRICAL

FIGURE 7-33. GROUND TO PLATFORM CABLE INSTALLATION - R1532I WITHOUT PLATFORM COIL CABLE AND WITH FOOTSWITCH

ITEM	PART NUMBER	QTY	DESCRIPTION	REV
	1001225492	Ref	GROUND TO PLATFORM CABLE INSTALLATION	A
		Ref	Note: Only Available on Japanese Specs.	
1	4240017	AR	Tie-Strap (Not Shown)	
2	1001223263	1	Platform Harness	
2	4460899	1	Receptacle, Female - 6 Position (To Item 3)	
2	4460464	4	Pin, Male	
2	4460943	2	Pin, Male	
2	4460754	1	Connector - 14 Position (To Console Box)	
2	4460465	8	Socket, Female	
2	4460944	2	Socket, Female	
2	4460466	4	Plug, Terminal	
2	4460891	1	Plug, Male - 2 Position (To Footswitch)	
2	4460465	2	Socket, Female	
2	4460897	1	Receptacle, Female - 2 Position (Footswitch Jumper)	
2	4460464	2	Pin, Male	
2	4460539	1	Plug, Male - 3 Position (To Overhead Switches)	
2	4460465	2	Socket, Female	
2	4460466	1	Plug, Terminal	
3	1001225377	1	Cable Assembly - Ground to Platform	
3	4460894	1	Plug, Male - 6 Position (To Platform Harness Item 2)	
3	4460465	4	Socket, Female	
3	4460944	2	Socket, Female	
3	4460899	1	Receptacle, Female - 6 Position (To Chassis Harness)	
3	4460464	4	Pin, Male	
3	4460943	2	Pin, Male	

SECTION 7 - ELECTRICAL

FIGURE 7-34. GROUND TO PLATFORM CABLE INSTALLATION - R1532I WITH PLATFORM COIL CABLE AND FOOTSWITCH

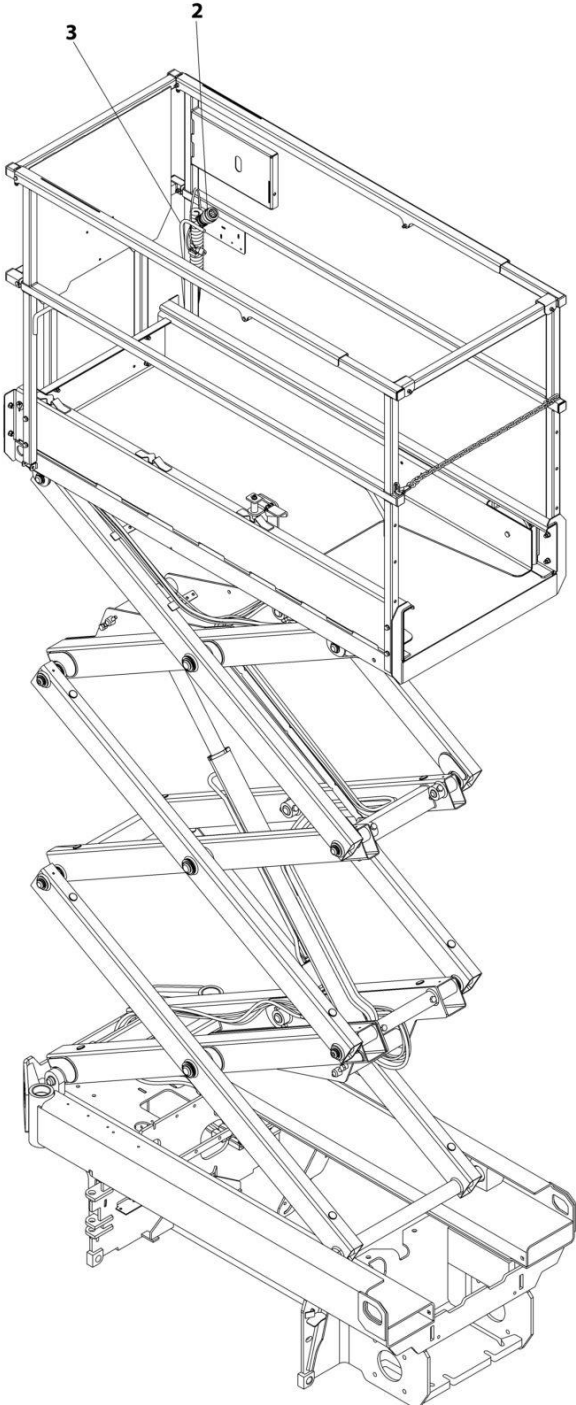

ART_1001225493

SECTION 7 - ELECTRICAL

FIGURE 7-34. GROUND TO PLATFORM CABLE INSTALLATION - R1532I WITH PLATFORM COIL CABLE AND FOOTSWITCH

ITEM	PART NUMBER	QTY	DESCRIPTION	REV
	1001225493	Ref	GROUND TO PLATFORM CABLE INSTALLATION	A
1	4240017	AR	Tie-Strap (Not Shown)	
2	1001223262	1	Platform Harness	
2	4460899	1	Receptacle, Female - 6 Position (To Item 3)	
2	4460464	4	Pin, Male	
2	4460943	2	Pin, Male	
2	4460754	1	Connector - 14 Position (To Console Box)	
2	4460465	8	Socket, Female	
2	4460944	2	Socket, Female	
2	4460466	4	Plug, Terminal	
2	4460891	1	Plug, Male - 2 Position (To Footswitch)	
2	4460465	2	Socket, Female	
2	4460897	1	Receptacle, Female - 2 Position (Footswitch Jumper)	
2	4460464	2	Pin, Male	
2	4460539	1	Plug, Male - 3 Position (To Overhead Switches)	
2	4460465	2	Socket, Female	
2	4460466	1	Plug, Terminal	
3	1001225377	1	Cable Assembly - Ground to Platform	
3	4460894	1	Plug, Male - 6 Position (To Platform Harness Item 2)	
3	4460465	4	Socket, Female	
3	4460944	2	Socket, Female	
3	4460899	1	Receptacle, Female - 6 Position (To Chassis Harness)	
3	4460464	4	Pin, Male	
3	4460943	2	Pin, Male	

SECTION 7 - ELECTRICAL

FIGURE 7-35. GROUND TO PLATFORM CABLE INSTALLATION – R1932i/R1932 WITHOUT PLATFORM COIL CABLE (ALL SPECS EXCEPT AUSTRALIAN AND KOREA SPECS)

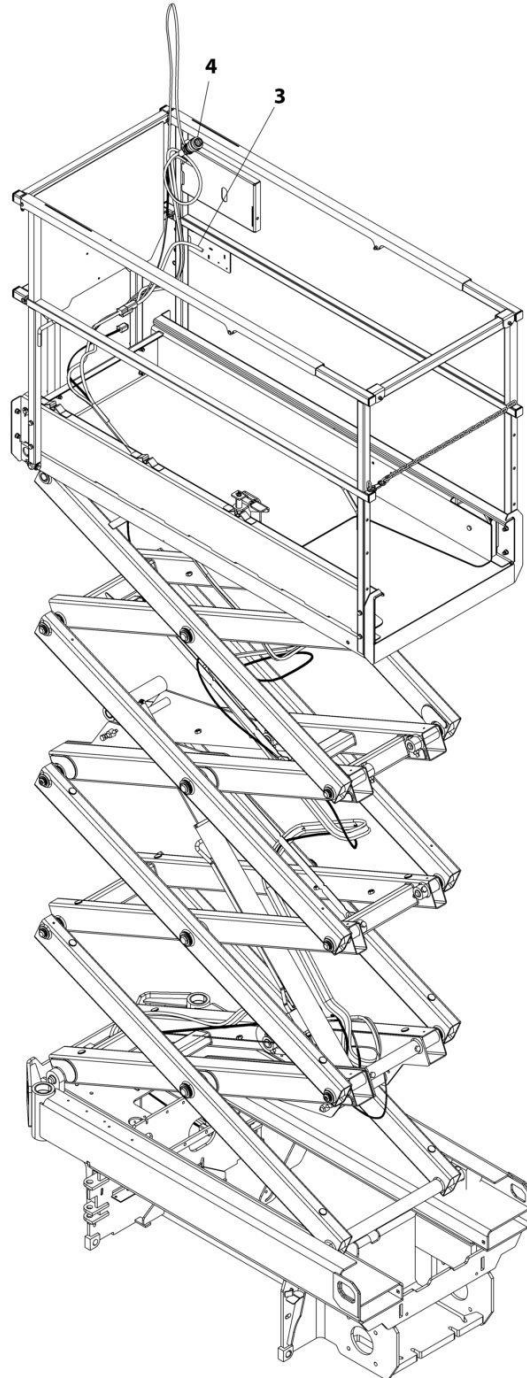

ART_1001201087

SECTION 7 - ELECTRICAL

FIGURE 7-35. GROUND TO PLATFORM CABLE INSTALLATION – R1932I/R1932 WITHOUT PLATFORM COIL CABLE (ALL SPECS EXCEPT AUSTRALIAN AND KOREA SPECS)

ITEM	PART NUMBER	QTY	DESCRIPTION	REV
	1001201087	Ref	GROUND TO PLATFORM CABLE INSTALLATION	E
1	4240017	AR	Tie-Strap (Not Shown)	
3	1001200811	1	Cable Assembly - Ground to Platform	
3	4460894	1	Plug, Male - 6 Position (To Platform Harness Item 4)	
3	4460465	4	Socket, Female	
3	4460944	2	Socket, Female	
3	4460899	1	Receptacle, Female - 6 Position (To Chassis Harness)	
3	4460464	4	Pin, Male	
3	4460943	2	Pin, Male	
4	1001200812	1	Platform Harness	
4	4460899	1	Receptacle, Female - 6 Position (To Item 3)	
4	4460464	4	Pin, Male	
4	4460943	2	Pin, Male	
4	4460754	1	Connector - 14 Position (To Console Box)	
4	4460465	8	Socket, Female	
4	4460466	6	Plug, Terminal	

SECTION 7 - ELECTRICAL

FIGURE 7-36. GROUND TO PLATFORM CABLE INSTALLATION - R1932 WITHOUT PLATFORM COIL CABLE (AUSTRALIAN SPECS)

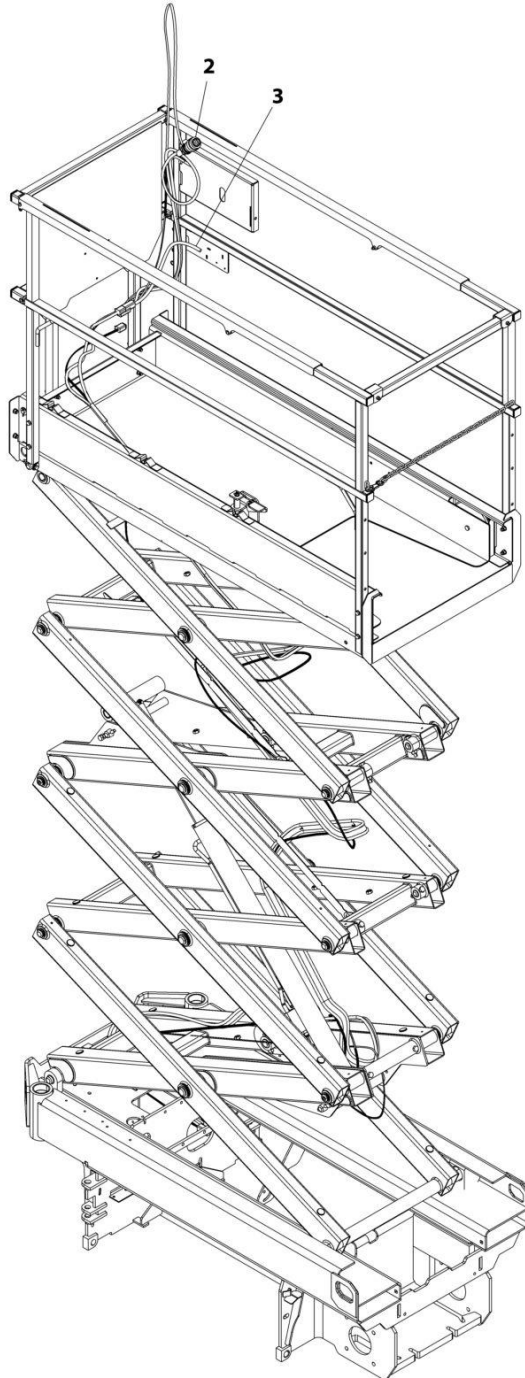

ART_1001230932

SECTION 7 - ELECTRICAL

FIGURE 7-36. GROUND TO PLATFORM CABLE INSTALLATION - R1932 WITHOUT PLATFORM COIL CABLE (AUSTRALIAN SPECS)

ITEM	PART NUMBER	QTY	DESCRIPTION	REV
	1001230932	Ref	GROUND TO PLATFORM CABLE INSTALLATION	A
1	4240017	AR	Tie-Strap (Not Shown)	
2	1001200812	1	Platform Harness	
2	4460899	1	Receptacle, Female - 6 Position (To Item 3)	
2	4460464	4	Pin, Male	
2	4460943	2	Pin, Male	
2	4460754	1	Connector - 14 Position (To Console Box)	
2	4460465	8	Socket, Female	
2	4460466	6	Plug, Terminal	
3	1001230839	1	Cable Assembly - Ground to Platform	
3	4460894	1	Plug, Male - 6 Position (To Platform Harness Item 2)	
3	4460465	4	Socket, Female	
3	4460944	2	Socket, Female	
3	4460899	1	Receptacle, Female - 6 Position (To Chassis Harness)	
3	4460464	4	Pin, Male	
3	4460943	2	Pin, Male	

SECTION 7 - ELECTRICAL

FIGURE 7-37. GROUND TO PLATFORM CABLE INSTALLATION - R1932I/R1932 WITH PLATFORM COIL CABLE (ALL SPECS EXCEPT AUSTRALIAN AND KOREA SPECS AND NOBLE)

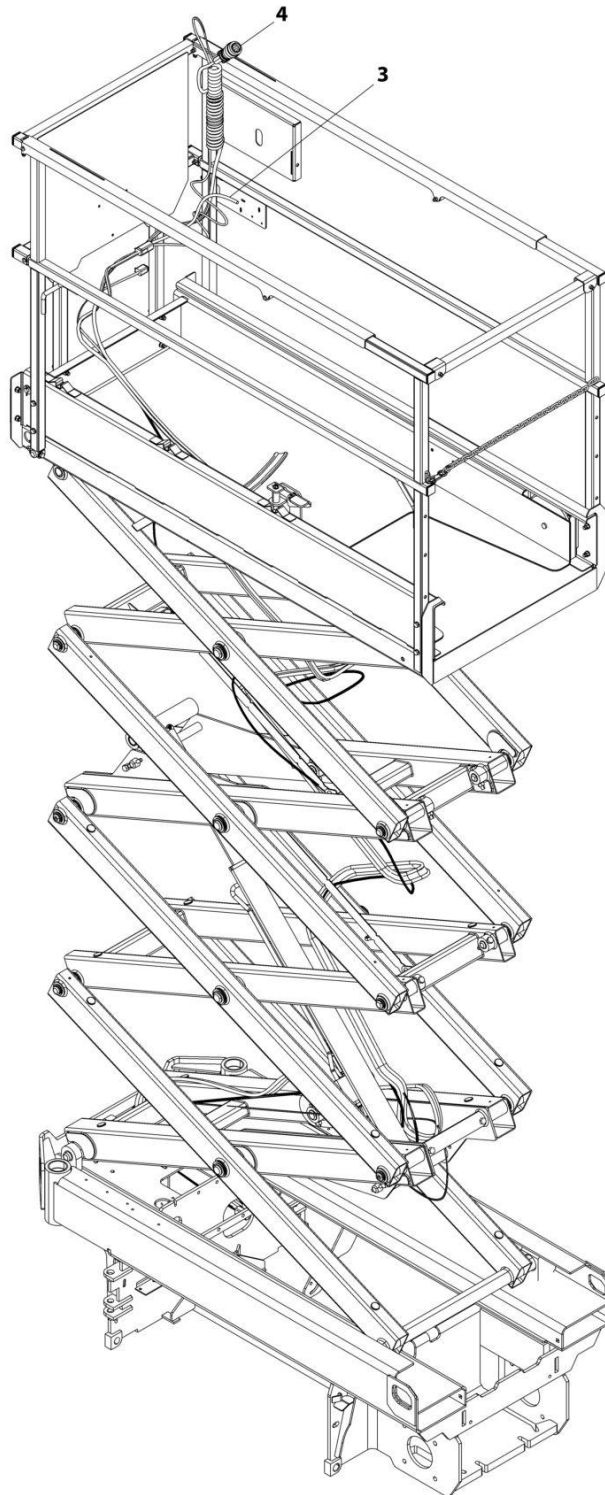

ART_1001203630

SECTION 7 - ELECTRICAL

FIGURE 7-37. GROUND TO PLATFORM CABLE INSTALLATION - R1932i/R1932 WITH PLATFORM COIL CABLE (ALL SPECS EXCEPT AUSTRALIAN AND KOREA SPECS AND NOBLE)

ITEM	PART NUMBER	QTY	DESCRIPTION	REV
	1001203630	Ref	GROUND TO PLATFORM CABLE INSTALLATION	E
1	4240017	AR	Tie-Strap (Not Shown)	
3	1001200811	1	Cable Assembly - Ground to Platform	
3	4460894	1	Plug, Male - 6 Position (To Platform Harness Item 4)	
3	4460465	4	Socket, Female	
3	4460944	2	Socket, Female	
3	4460899	1	Receptacle, Female - 6 Position (To Chassis Harness)	
3	4460464	4	Pin, Male	
3	4460943	2	Pin, Male	
4	1001202184	1	Platform Harness	
4	4460899	1	Receptacle, Female - 6 Position (To Item 3)	
4	4460464	4	Pin, Male	
4	4460943	2	Pin, Male	
4	4460754	1	Connector - 14 Position (To Console Box)	
4	4460465	8	Socket, Female	
4	4460466	6	Plug, Terminal	

SECTION 7 - ELECTRICAL

FIGURE 7-38. GROUND TO PLATFORM CABLE INSTALLATION - R1932 WITH PLATFORM COIL CABLE (AUSTRALIAN SPECS)

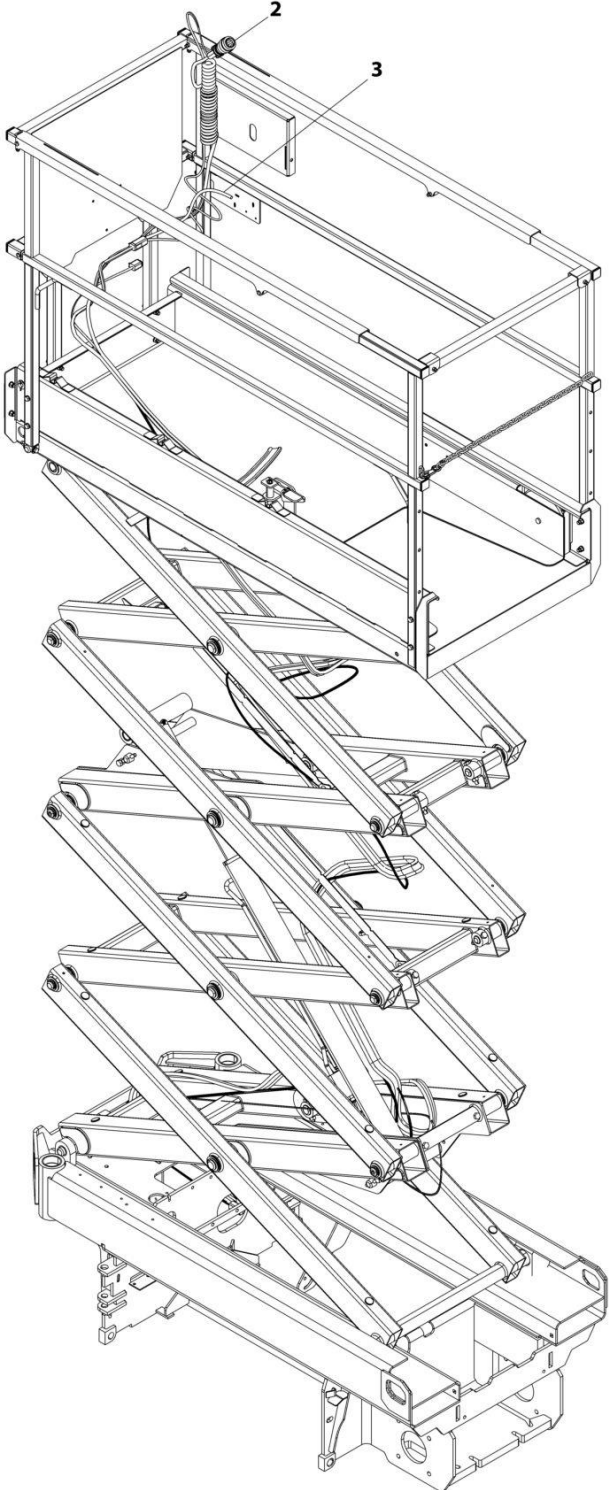

ART_1001230933

SECTION 7 - ELECTRICAL

FIGURE 7-38. GROUND TO PLATFORM CABLE INSTALLATION - R1932 WITH PLATFORM COIL CABLE (AUSTRALIAN SPECS)

ITEM	PART NUMBER	QTY	DESCRIPTION	REV
	1001230933	Ref	GROUND TO PLATFORM CABLE INSTALLATION	A
1	4240017	AR	Tie-Strap (Not Shown)	
2	1001202184	1	Platform Harness	
2	4460899	1	Receptacle, Female - 6 Position (To Item 3)	
2	4460464	4	Pin, Male	
2	4460943	2	Pin, Male	
2	4460754	1	Connector - 14 Position (To Console Box)	
2	4460465	8	Socket, Female	
2	4460466	6	Plug, Terminal	
3	1001230839	1	Cable Assembly - Ground to Platform	
3	4460894	1	Plug, Male - 6 Position (To Platform Harness Item 2)	
3	4460465	4	Socket, Female	
3	4460944	2	Socket, Female	
3	4460899	1	Receptacle, Female - 6 Position (To Chassis Harness)	
3	4460464	4	Pin, Male	
3	4460943	2	Pin, Male	

SECTION 7 - ELECTRICAL

FIGURE 7-39. GROUND TO PLATFORM CABLE INSTALLATION - R1932i/R1932 WITHOUT PLATFORM COIL CABLE AND WITH FOOTSWITCH

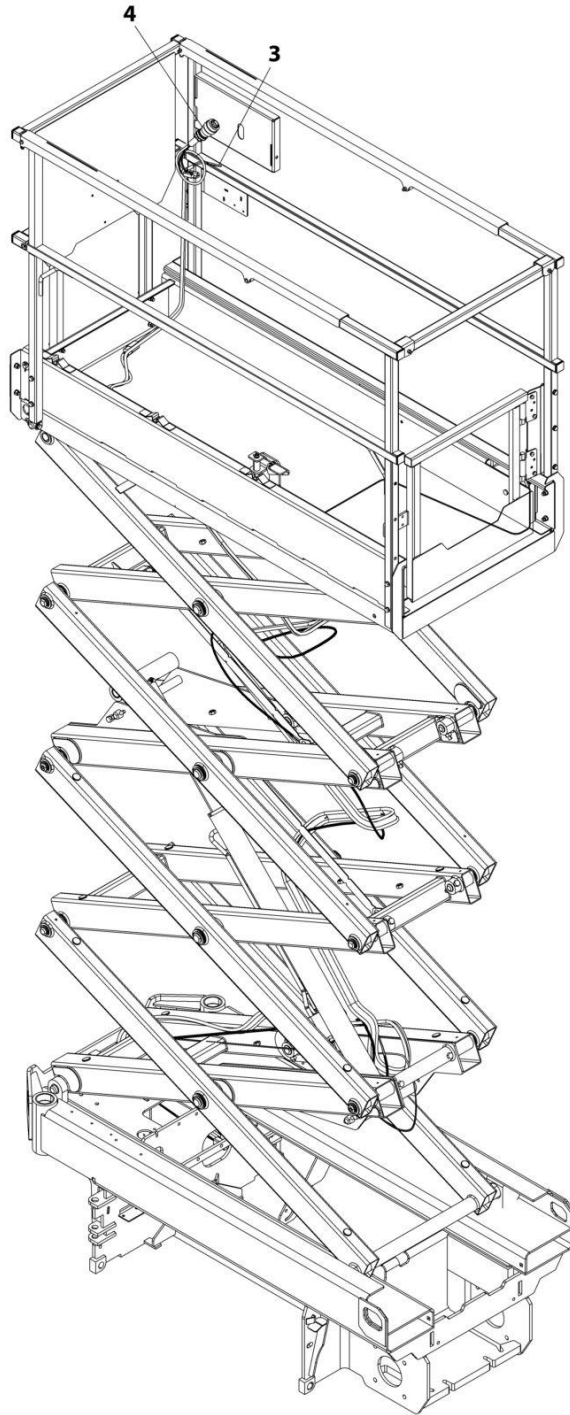

ART_1001201129_F

SECTION 7 - ELECTRICAL

FIGURE 7-39. GROUND TO PLATFORM CABLE INSTALLATION - R1932I/R1932 WITHOUT PLATFORM COIL CABLE AND WITH FOOTSWITCH

ITEM	PART NUMBER	QTY	DESCRIPTION	REV
	1001201129	Ref	GROUND TO PLATFORM CABLE INSTALLATION	F
		Ref	Note: Only Available on Japanese Specs.	
1	4240017	AR	Tie-Strap (Not Shown)	
3	1001200811	1	Cable Assembly - Ground to Platform	
3	4460894	1	Plug, Male - 6 Position (To Platform Harness Item 4)	
3	4460465	4	Socket, Female	
3	4460944	2	Socket, Female	
3	4460899	1	Receptacle, Female - 6 Position (To Chassis Harness)	
3	4460464	4	Pin, Male	
3	4460943	2	Pin, Male	
4	1001223263	1	Platform Harness	
4	4460899	1	Receptacle, Female - 6 Position (To Item 3)	
4	4460464	4	Pin, Male	
4	4460943	2	Pin, Male	
4	4460754	1	Connector - 14 Position (To Console Box)	
4	4460465	8	Socket, Female	
4	4460944	2	Socket, Female	
4	4460466	4	Plug, Terminal	
4	4460891	1	Plug, Male - 2 Position (To Footswitch)	
4	4460465	2	Socket, Female	
4	4460897	1	Receptacle, Female - 2 Position (Footswitch Jumper)	
4	4460464	2	Pin, Male	
4	4460539	1	Plug, Male - 3 Position (To Overhead Switches)	
4	4460465	2	Socket, Female	
4	4460466	1	Plug, Terminal	

SECTION 7 - ELECTRICAL

FIGURE 7-40. GROUND TO PLATFORM CABLE INSTALLATION - R1932I/R1932 WITH PLATFORM COIL CABLE AND FOOTSWITCH

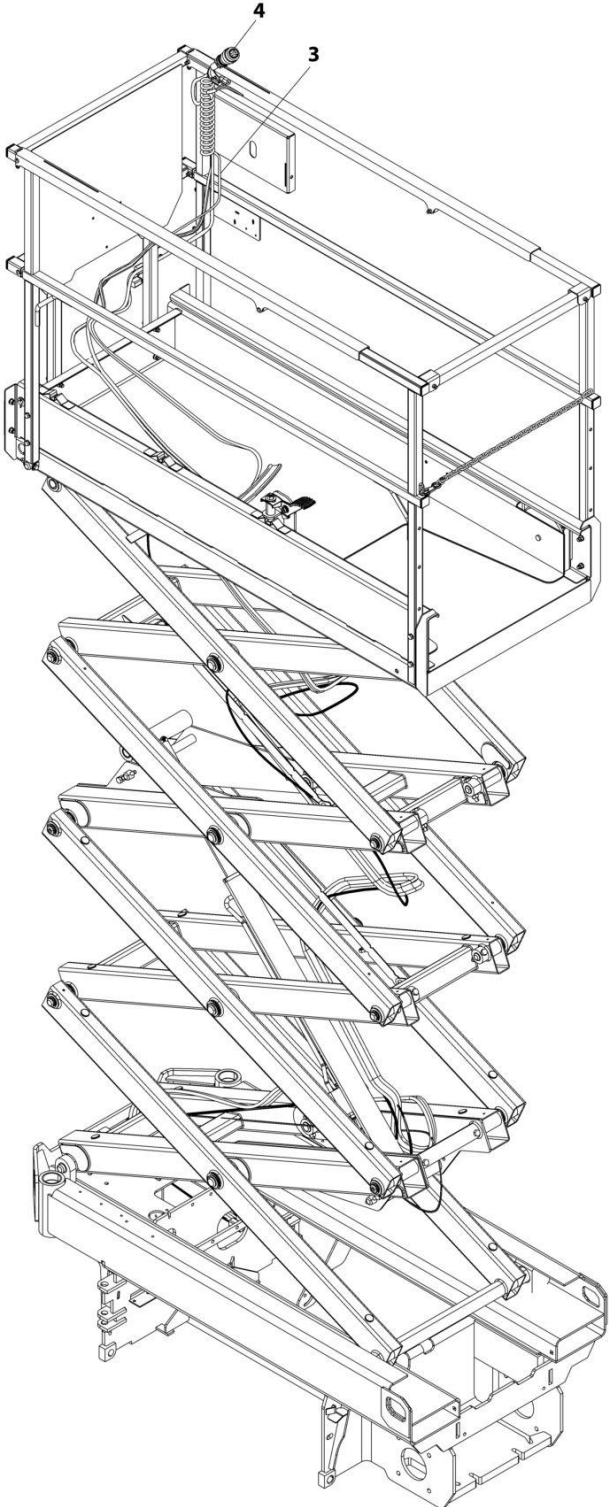

ART_1001203631_F

SECTION 7 - ELECTRICAL

FIGURE 7-40. GROUND TO PLATFORM CABLE INSTALLATION - R1932i/R1932 WITH PLATFORM COIL CABLE AND FOOTSWITCH

ITEM	PART NUMBER	QTY	DESCRIPTION	REV
	1001203631	Ref	GROUND TO PLATFORM CABLE INSTALLATION	F
		Ref	Note: Only Available on Japanese Specs.	
1	4240017	AR	Tie-Strap (Not Shown)	
3	1001200811	1	Cable Assembly - Ground to Platform	
3	4460894	1	Plug, Male - 6 Position (To Platform Harness Item 4)	
3	4460465	4	Socket, Female	
3	4460944	2	Socket, Female	
3	4460899	1	Receptacle, Female - 6 Position (To Chassis Harness)	
3	4460464	4	Pin, Male	
3	4460943	2	Pin, Male	
4	1001223262	1	Platform Harness	
4	4460899	1	Receptacle, Female - 6 Position (To Item 3)	
4	4460464	4	Pin, Male	
4	4460943	2	Pin, Male	
4	4460754	1	Connector - 14 Position (To Console Box)	
4	4460465	8	Socket, Female	
4	4460944	2	Socket, Female	
4	4460466	4	Plug, Terminal	
4	4460891	1	Plug, Male - 2 Position (To Footswitch)	
4	4460465	2	Socket, Female	
4	4460897	1	Receptacle, Female - 2 Position (Footswitch Jumper)	
4	4460464	2	Pin, Male	
4	4460539	1	Plug, Male - 3 Position (To Overhead Switches)	
4	4460465	2	Socket, Female	
4	4460466	1	Plug, Terminal	

SECTION 7 - ELECTRICAL

FIGURE 7-41. GROUND TO PLATFORM CABLE INSTALLATION - R1932I/R1932 WITH PLATFORM STRAIGHT CABLE ONLY (MACHINES WITH SN STARTING WITH 12)

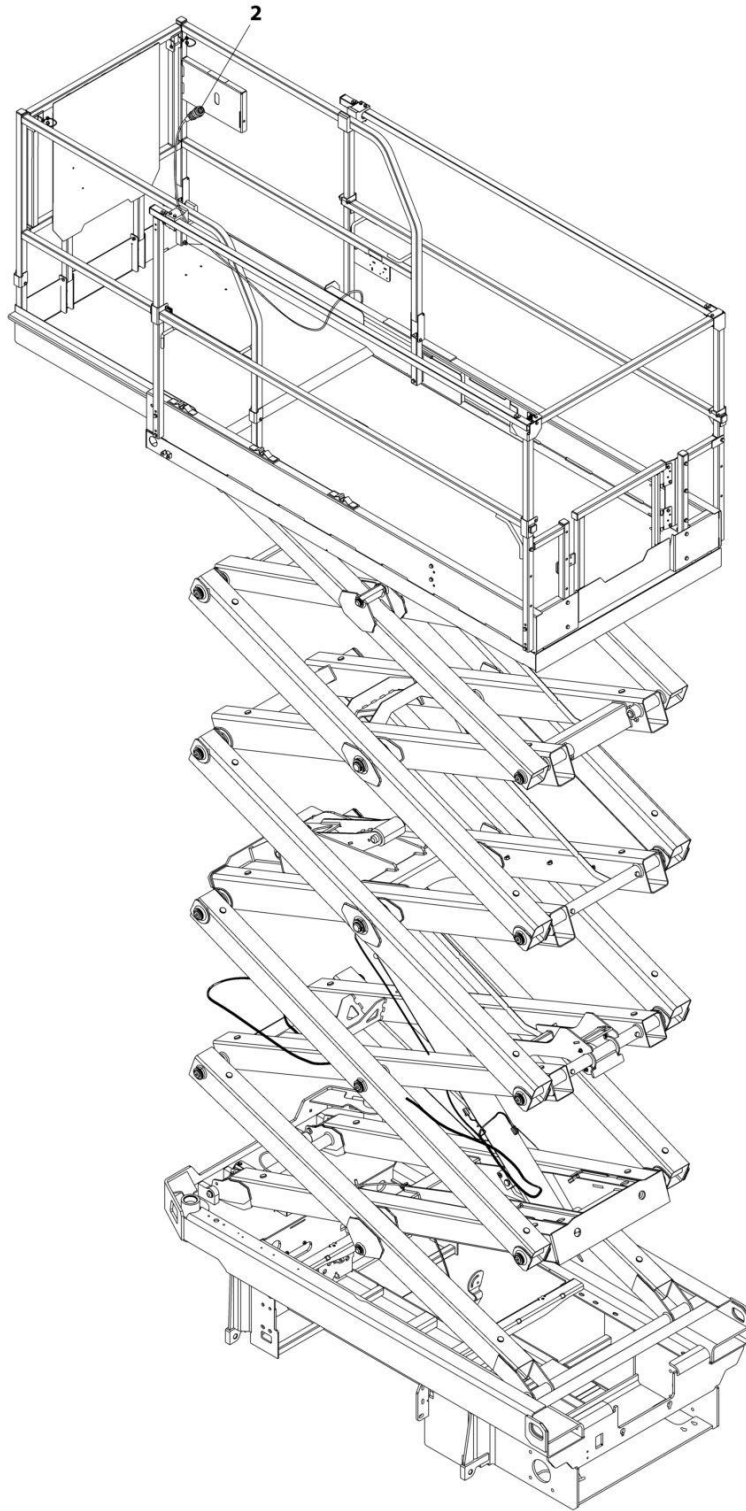

ART_1001223650

SECTION 7 - ELECTRICAL

FIGURE 7-41. GROUND TO PLATFORM CABLE INSTALLATION - R1932I/R1932 WITH PLATFORM STRAIGHT CABLE ONLY (MACHINES WITH SN STARTING WITH 12)

ITEM	PART NUMBER	QTY	DESCRIPTION	REV
	1001223650	Ref	GROUND TO PLATFORM CABLE INSTALLATION	A
1	4240017	AR	Tie-Strap (Not Shown)	
2	1001200812	1	Platform Harness	
2	4460899	1	Receptacle, Female - 6 position (To Platform/AC Cable Connector)	
2	4460464	4	Pin, Male	
2	4460943	2	Pin, Male	
2	4460754	1	Connector - 14 Position (To Console Box)	
2	4460465	8	Socket, Female	
2	4460466	6	Plug, Terminal	

SECTION 7 - ELECTRICAL

FIGURE 7-42. GROUND TO PLATFORM CABLE INSTALLATION - R1932I/R1932 WITH PLATFORM COIL CABLE ONLY (MACHINES WITH SN STARTING WITH 12)

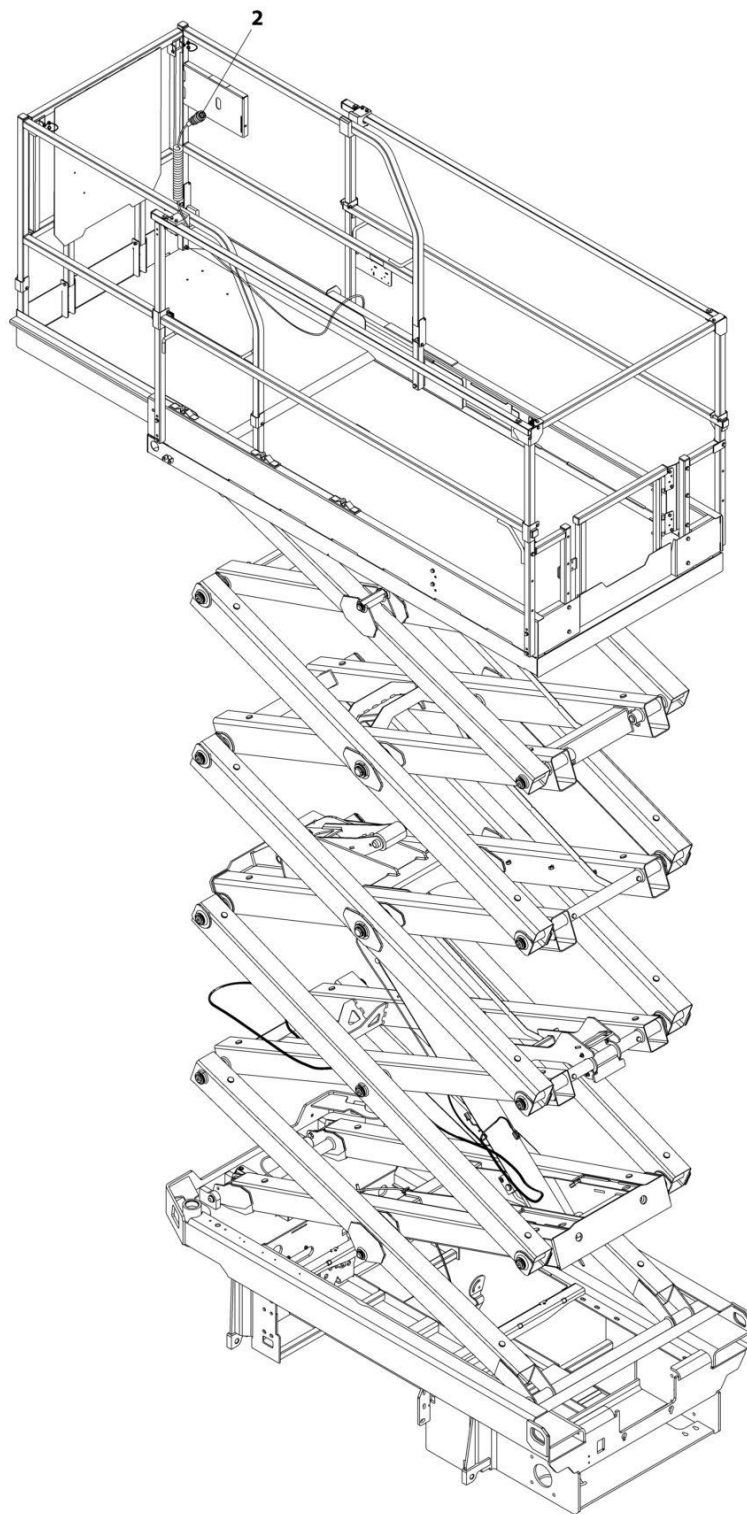

ART_1001223651

SECTION 7 - ELECTRICAL

FIGURE 7-42. GROUND TO PLATFORM CABLE INSTALLATION - R1932i/R1932 WITH PLATFORM COIL CABLE ONLY (MACHINES WITH SN STARTING WITH 12)

ITEM	PART NUMBER	QTY	DESCRIPTION	REV
	1001223651	Ref	GROUND TO PLATFORM CABLE INSTALLATION	A
1	4240017	AR	Tie-Strap (Not Shown)	
2	1001202184	1	Platform Harness	
2	4460899	1	Receptacle, Female - 6 position (To Platform/AC Cable Connector)	
2	4460464	4	Pin, Male	
2	4460943	2	Pin, Male	
2	4460754	1	Connector - 14 Position (To Console Box)	
2	4460465	8	Socket, Female	
2	4460466	6	Plug, Terminal	

SECTION 7 - ELECTRICAL

FIGURE 7-43. GROUND TO PLATFORM CABLE INSTALLATION - R1932 WITHOUT FOOTSWITCH
(MACHINES WITH SN STARTING WITH G2)

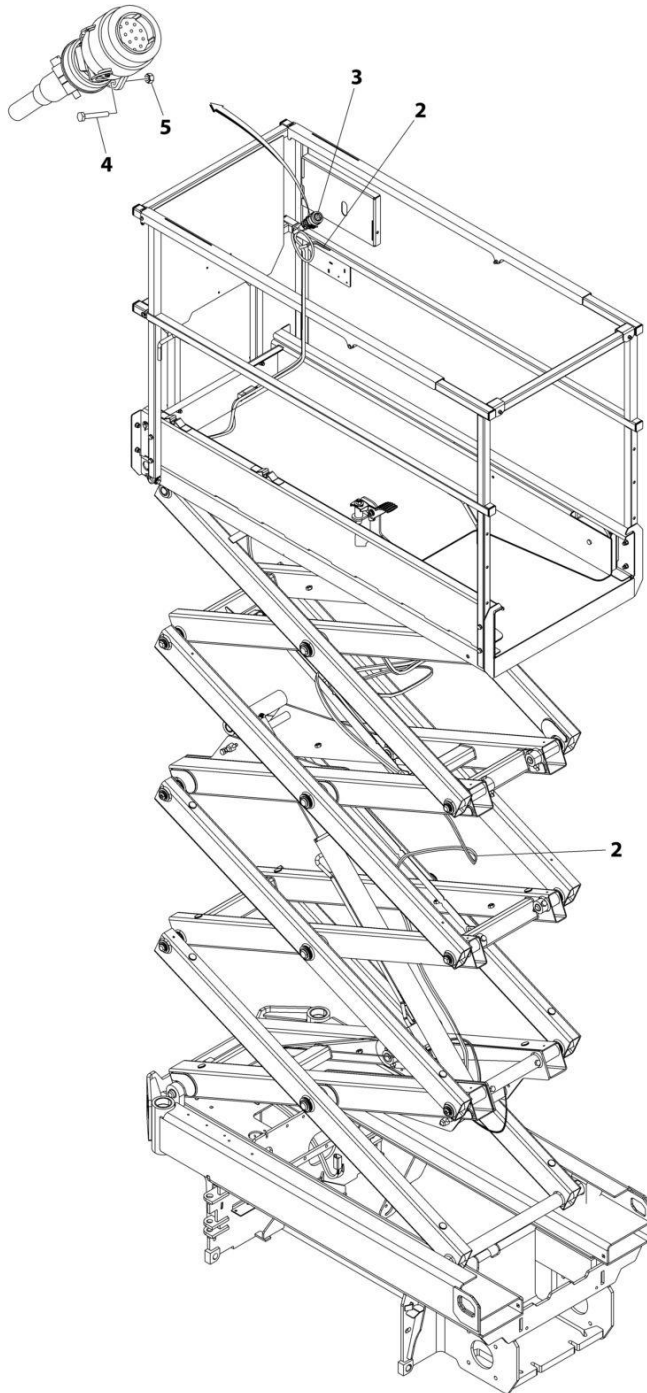

ART_1001270899

SECTION 7 - ELECTRICAL

**FIGURE 7-43. GROUND TO PLATFORM CABLE INSTALLATION - R1932 WITHOUT FOOTSWITCH
(MACHINES WITH SN STARTING WITH G2)**

ITEM	PART NUMBER	QTY	DESCRIPTION	REV
	1001270899	Ref	GROUND TO PLATFORM CABLE INSTALLATION	C
1	4240017	AR	Tie-Strap (Not Shown)	
2	1001239544	1	Cable Assembly - Ground to Platform	
2	4460894	1	Plug, Male - 6 Position (To Platform Harness Item 4)	
2	4460465	4	Socket, Female	
2	4460944	2	Socket, Female	
2	4460899	1	Receptacle, Female - 6 Position (To Chassis Harness)	
2	4460464	4	Pin, Male	
2	4460943	2	Pin, Male	
3	1001270443	1	Platform Harness	
3	4460899	1	Receptacle, Female - 6 Position (To Item 3)	
3	4460464	4	Pin, Male	
3	4460943	2	Pin, Male	
3	1001269947	1	Connector - 14 Position (To Console Box)	
3	1001269944	6	Socket, Female	
3	1001269949	2	Socket, Female	
4	0760310	2	Bolt M3 x 20	
5	3290305	2	Nut M3	

SECTION 7 - ELECTRICAL

FIGURE 7-44. GROUND TO PLATFORM CABLE INSTALLATION - R1932 WITH FOOTSWITCH
(MACHINES WITH SN STARTING WITH G2)

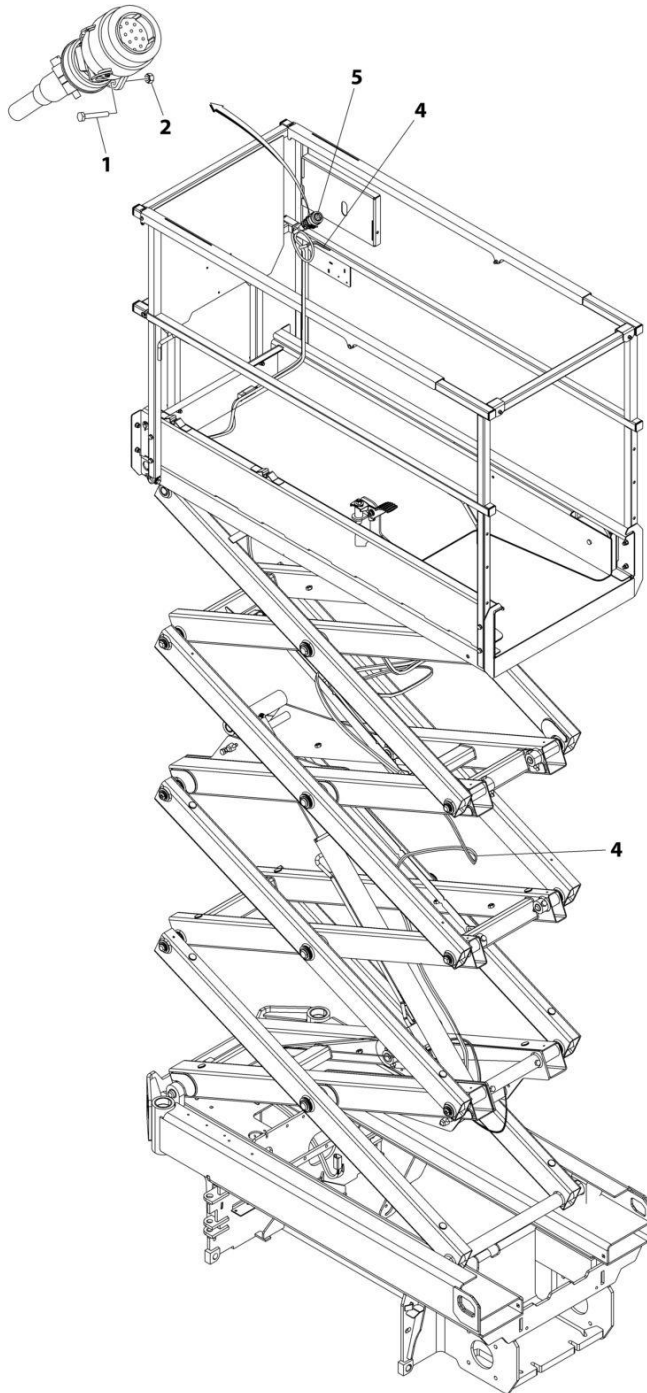

ART_1001286164

SECTION 7 - ELECTRICAL

**FIGURE 7-44. GROUND TO PLATFORM CABLE INSTALLATION - R1932 WITH FOOTSWITCH
(MACHINES WITH SN STARTING WITH G2)**

ITEM	PART NUMBER	QTY	DESCRIPTION	REV
	1001286164	Ref	GROUND TO PLATFORM CABLE INSTALLATION	A
1	0760310	2	Bolt M3 x 20	
2	3290305	2	Nut M3	
3	4240017	AR	Tie-Strap (Not Shown)	
4	1001239544	1	Cable Assembly - Ground to Platform	
4	4460894	1	Plug, Male - 6 Position (To Platform Harness Item 4)	
4	4460465	4	Socket, Female	
4	4460944	2	Socket, Female	
4	4460899	1	Receptacle, Female - 6 Position (To Chassis Harness)	
4	4460464	4	Pin, Male	
4	4460943	2	Pin, Male	
5	1001286166	1	Platform Harness (See Separate Breakdown in this Section)	

SECTION 7 - ELECTRICAL

FIGURE 7-45. JUMPER HARNESS

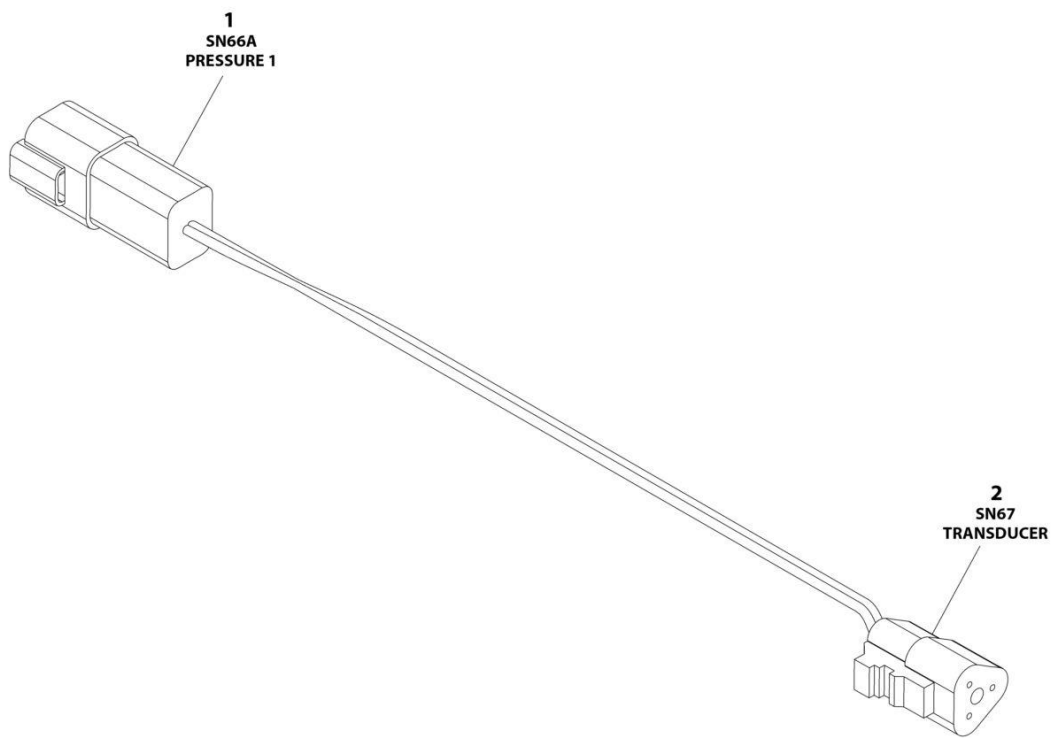

ART_1001285829

SECTION 7 - ELECTRICAL

FIGURE 7-45. JUMPER HARNESS

ITEM	PART NUMBER	QTY	DESCRIPTION	REV
	1001285829	Ref	JUMPER HARNESS TO LIFT DOWN	C
1	4460932	1	Connector	
1	4460464	2	Pin	
1	4460466	2	Plug	
2	4460539	1	Connector	
2	4460465	2	Pin	
2	4460466	1	Plug	

SECTION 7 - ELECTRICAL

FIGURE 7-46. LIFT DOWN HARNESS - WITH LSS

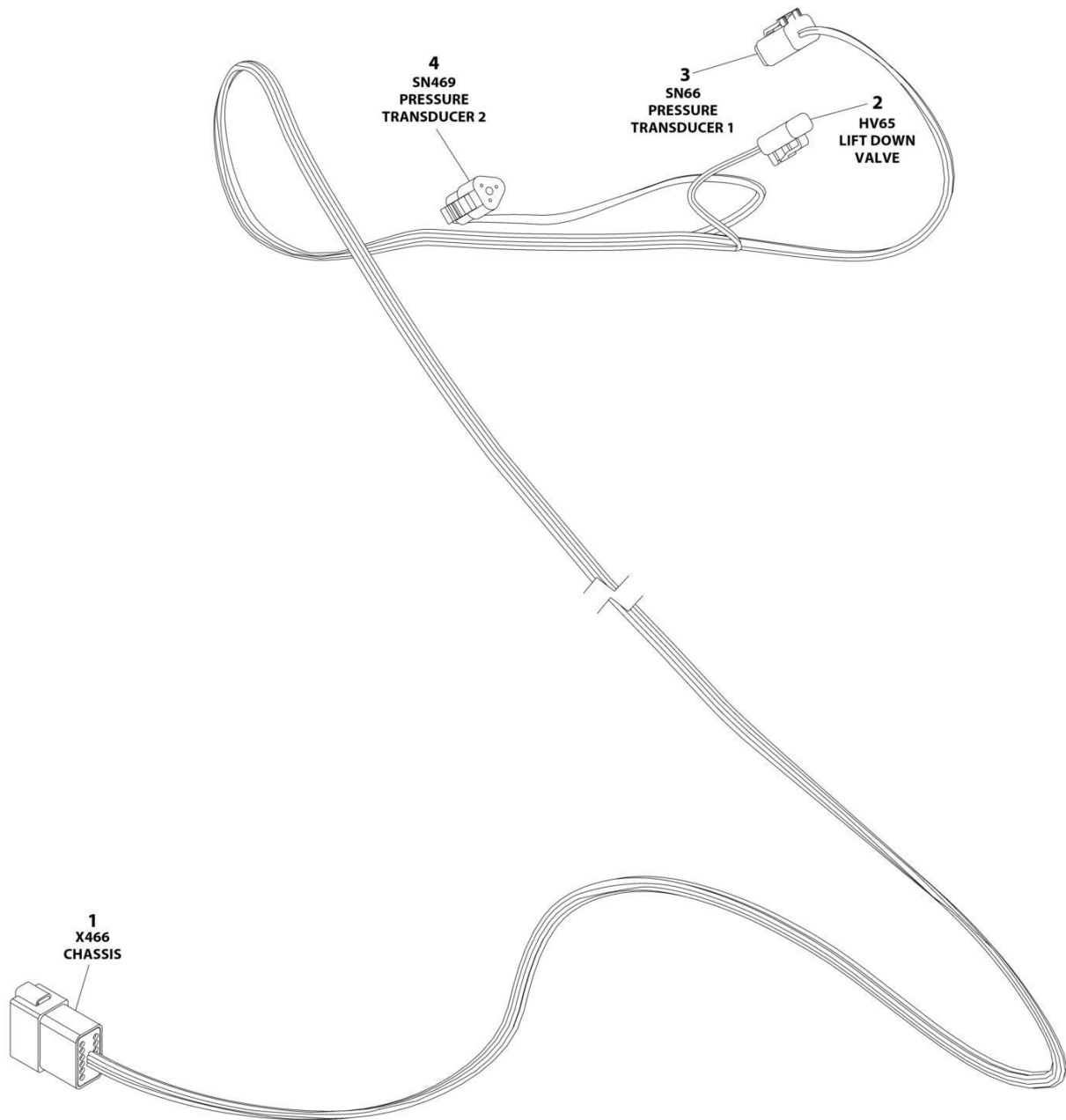

ART_1001222687_B

SECTION 7 - ELECTRICAL

FIGURE 7-46. LIFT DOWN HARNESS - WITH LSS

ITEM	PART NUMBER	QTY	DESCRIPTION	REV
	1001222687	Ref	LIFT DOWN HARNESS - WITH LSS	B
1	4460970	1	Receptacle, Female - 12 Position	
1	4460464	9	Pin, Male	
1	4460466	3	Plug, Terminal	
2	4460891	1	Plug, Male - 4 Position	
2	4460465	2	Socket, Female	
3	4460884	1	Plug, Male - 4 Position	
3	4460465	4	Socket, Female	
4	4460539	1	Plug, Male - 3 Position	
4	4460465	3	Socket, Female	

SECTION 7 - ELECTRICAL

FIGURE 7-47. LIGHT HARNESS

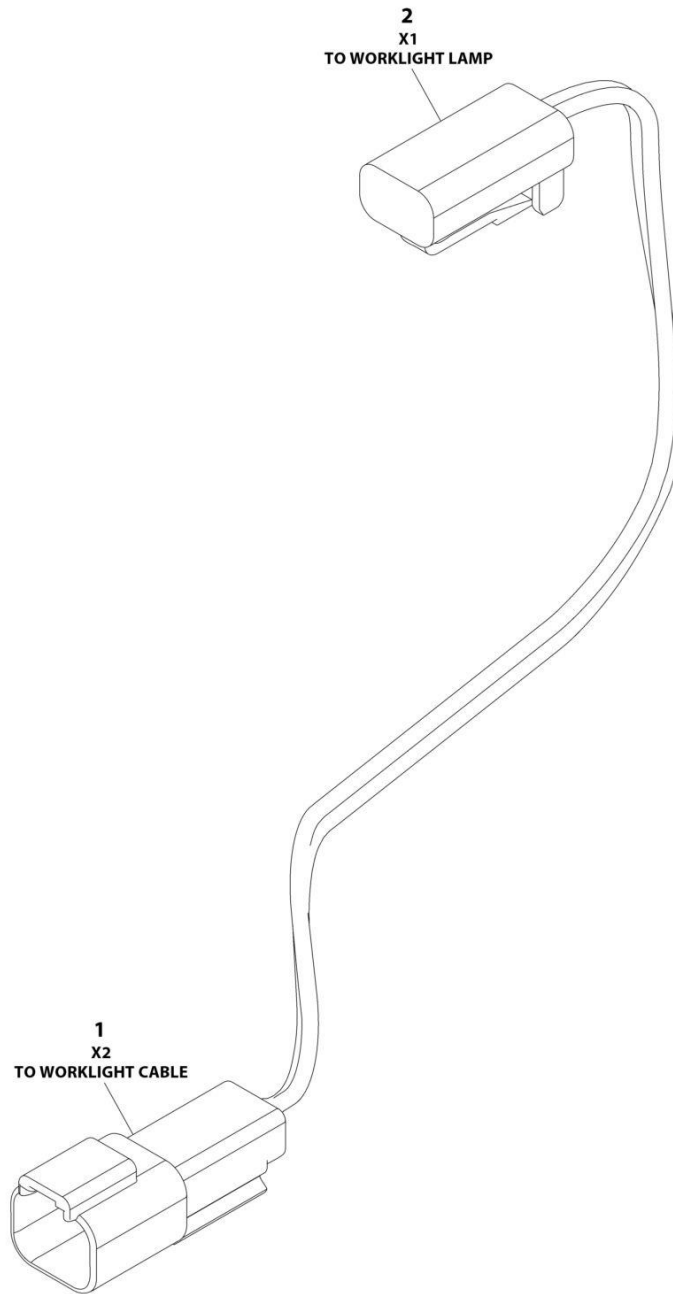

ART_1001274026

SECTION 7 - ELECTRICAL

FIGURE 7-47. LIGHT HARNESS

ITEM	PART NUMBER	QTY	DESCRIPTION	REV
	1001274026	Ref	HARNESS, LIGHT	A
1	4460897	1	Receptacle, Female -2 Position	
1	4460464	2	Pin, Male	
2	4460891	1	Plug, Male 2 Position	
2	4460465	2	Socket, Female	

SECTION 7 - ELECTRICAL

FIGURE 7-48. PLATFORM BOX HARNESS (MACHINES WITH SN STARTING WITH 12, B2, AND M2)

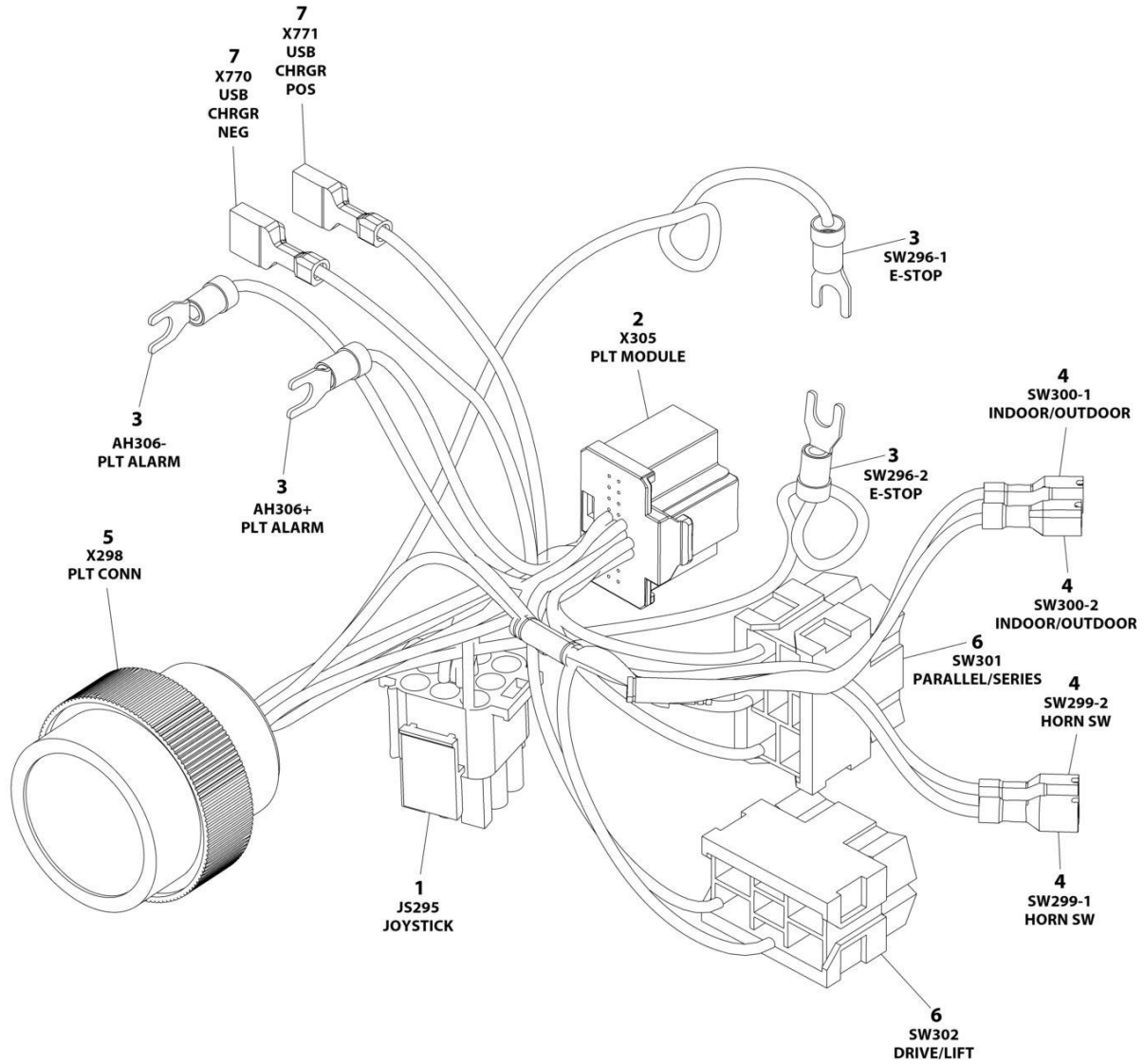

ART_1001200819

SECTION 7 - ELECTRICAL

FIGURE 7-48. PLATFORM BOX HARNESS (MACHINES WITH SN STARTING WITH 12, B2, AND M2)

ITEM	PART NUMBER	QTY	DESCRIPTION	REV
	1001200819	Ref	PLATFORM CONTROL BOX HARNESS	E
1	4460265	1	Plug, Male - 9 Position	
1	4460267	6	Pin, Male	
2	1001212036	1	Connector - 20 Position	
2	1001212035	16	Terminal	
3	4460183	4	Terminal, Fork	
4	1001201885	4	Terminal with Cover	
5	4461016	1	Connector - 14 Position	
5	4460464	8	Pin, Male	
5	4460466	6	Plug, Terminal	
6	4460418	2	Connector - 6 Position	
6	1001159186	5	Terminal	
7	1001194421	2	Terminal	

SECTION 7 - ELECTRICAL

FIGURE 7-49. PLATFORM BOX HARNESS (MACHINES WITH SN STARTING WITH G2) (CHINA AND ANSI EXPORT SPEC)

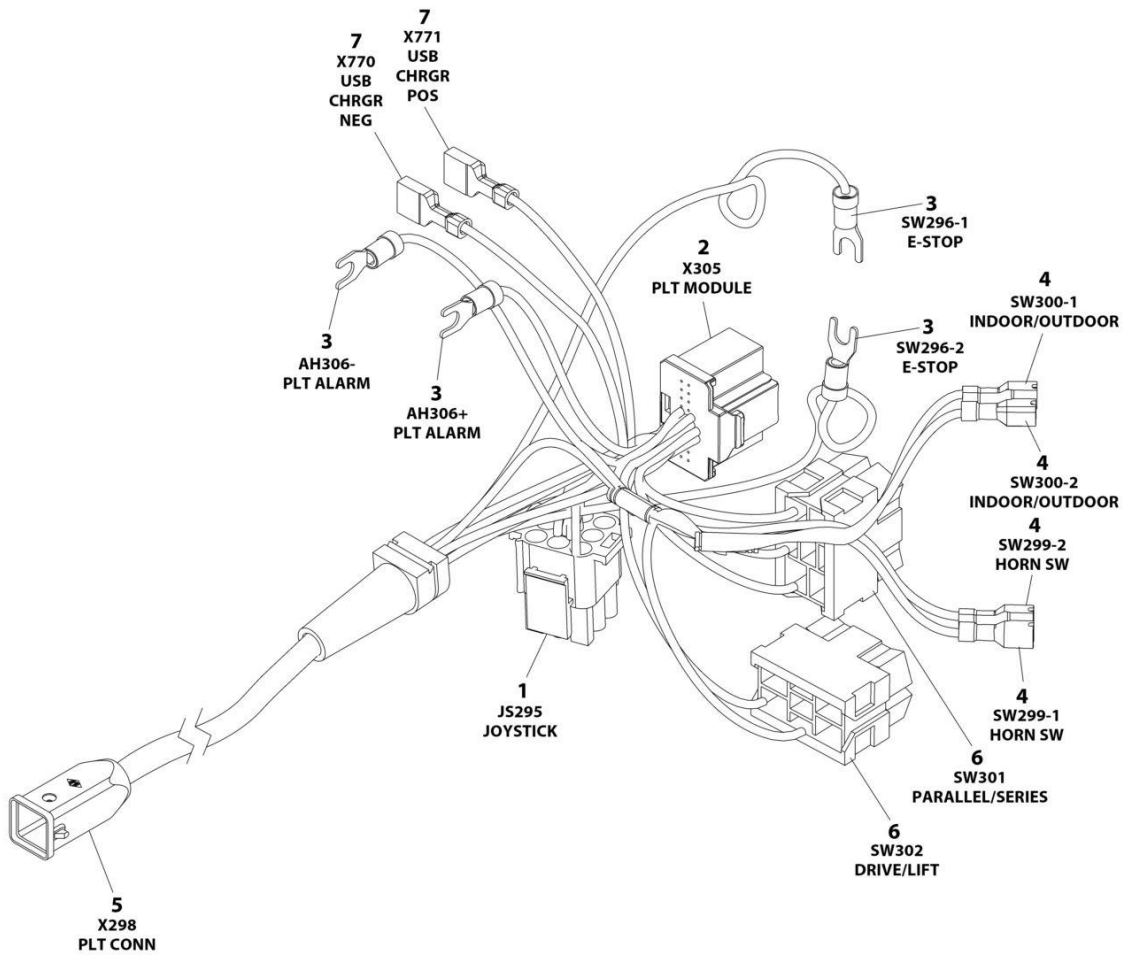

ART_1001269999

SECTION 7 - ELECTRICAL

FIGURE 7-49. PLATFORM BOX HARNESS (MACHINES WITH SN STARTING WITH G2) (CHINA AND ANSI EXPORT SPEC)

ITEM	PART NUMBER	QTY	DESCRIPTION	REV
	1001269999	Ref	PLATFORM CONTROL BOX HARNESS	A
1	4460265	1	Plug, Male - 9 Position	
1	4460267	7	Pin, Male	
2	1001212036	1	Connector - 20 Position	
2	1001212035	17	Terminal	
3	4460183	4	Terminal, Fork	
4	1001201885	4	Terminal with Cover	
5	1001269946	1	Connector - 12 Position	
5	1001269943	10	Pin, Male	
6	4460418	2	Connector - 6 Position	
6	1001159186	5	Terminal	
7	1001194421	2	Terminal	

SECTION 7 - ELECTRICAL

FIGURE 7-50. PLATFORM BOX HARNESS (MACHINES WITH SN STARTING WITH G2) (ANSI EXPORT SPEC ONLY)

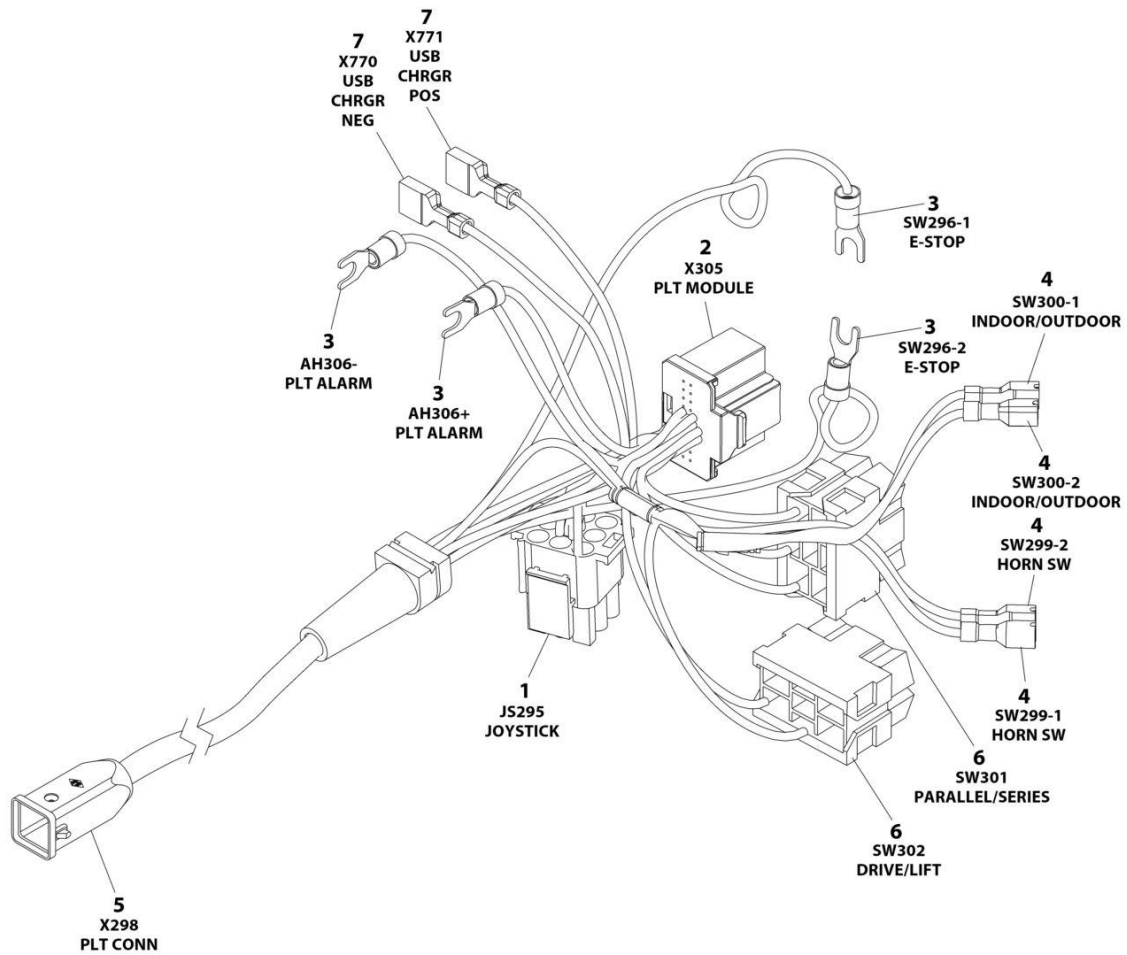

ART_1001286161

SECTION 7 - ELECTRICAL

FIGURE 7-50. PLATFORM BOX HARNESS (MACHINES WITH SN STARTING WITH G2) (ANSI EXPORT SPEC ONLY)

ITEM	PART NUMBER	QTY	DESCRIPTION	REV
	1001286161	Ref	PLATFORM CONTROL BOX HARNESS	A
1	4460265	1	Plug, Male - 9 Position	
1	4460267	7	Pin, Male	
2	1001212036	1	Connector - 20 Position	
2	1001212035	17	Terminal	
3	4460183	4	Terminal, Fork	
4	1001201885	4	Terminal with Cover	
5	1001269946	1	Connector - 12 Position	
5	1001269943	10	Pin, Male	
6	4460418	2	Connector - 6 Position	
6	1001159186	5	Terminal	
7	1001194421	2	Terminal	

SECTION 7 - ELECTRICAL

FIGURE 7-51. PLATFORM HARNESS - R1932 WITH FOOTSWITCH (MACHINES WITH SN STARTING WITH G2)

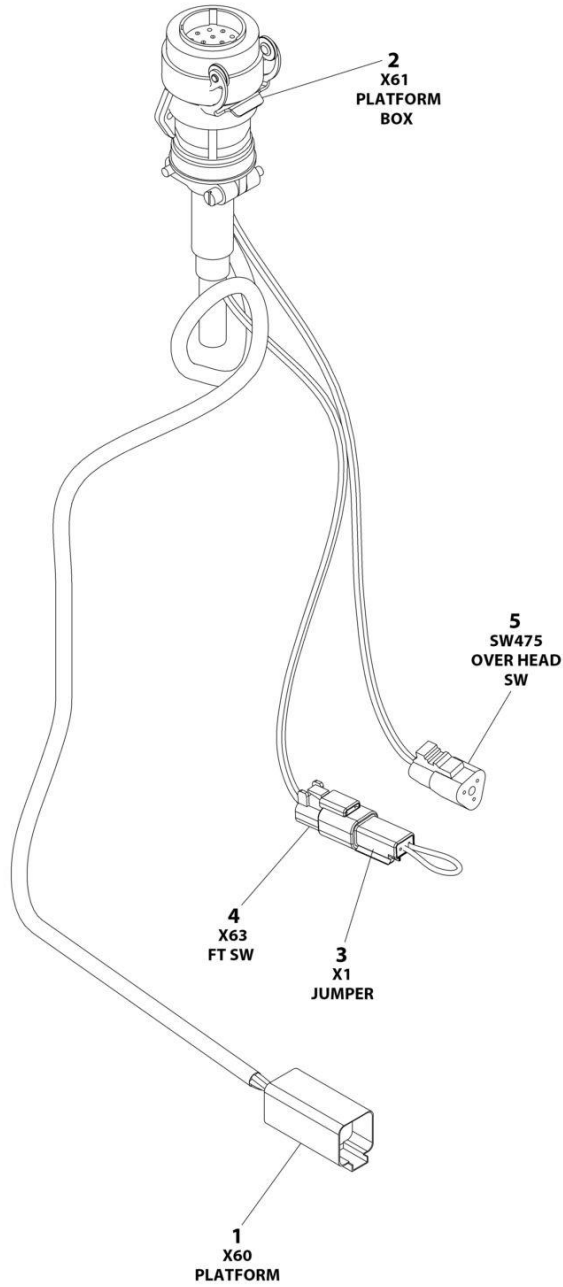

ART_1001286166

SECTION 7 - ELECTRICAL

FIGURE 7-51. PLATFORM HARNESS - R1932 WITH FOOTSWITCH (MACHINES WITH SN STARTING WITH G2)

ITEM	PART NUMBER	QTY	DESCRIPTION	REV
	1001286166	Ref	PLATFORM HARNESS	A
1	4460899	1	Connector	
1	4460464	4	Pin - Nickel	
1	4460943	2	Pin - Gold	
2	1001269947	1	Connector	
2	1001269944	8	Socket - Silver	
2	1001269949	2	Socket - Gold	
3	4460897	1	Connector	
3	4460464	2	Pin	
4	4460891	1	Connector	
4	4460465	2	Socket	
5	4460539	1	Connector	
5	4460565	2	Socket	
5	4460466	1	Plug	

SECTION 7 - ELECTRICAL

FIGURE 7-52. RECEPTACLE BOX KIT - 110V GFI

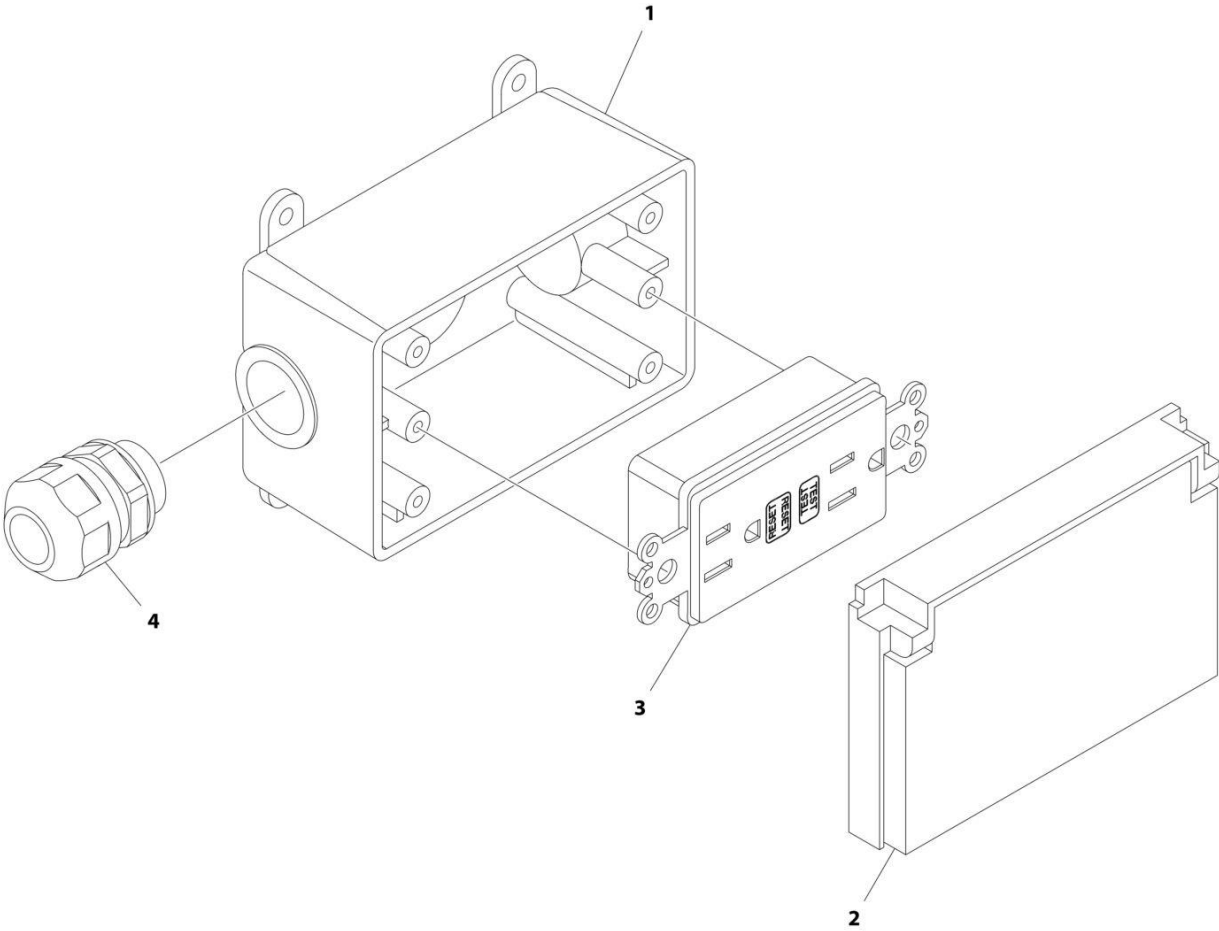

ART_2902431

SECTION 7 - ELECTRICAL

FIGURE 7-52. RECEPTACLE BOX KIT - 110V GFI

ITEM	PART NUMBER	QTY	DESCRIPTION	REV
	2902431	Ref	RECEPTACLE BOX KIT - 110V GFI	D
1	0861731	1	Box, Receptacle	
2	1671207	1	Cover, Receptacle	
3	4460346	1	Receptacle	
4	4460662	1	Connector, Strain Relief	

SECTION 7 - ELECTRICAL

FIGURE 7-53. RECEPTACLE BOX KIT - 110V IEC YELLOW (CE & UK CA SPEC)

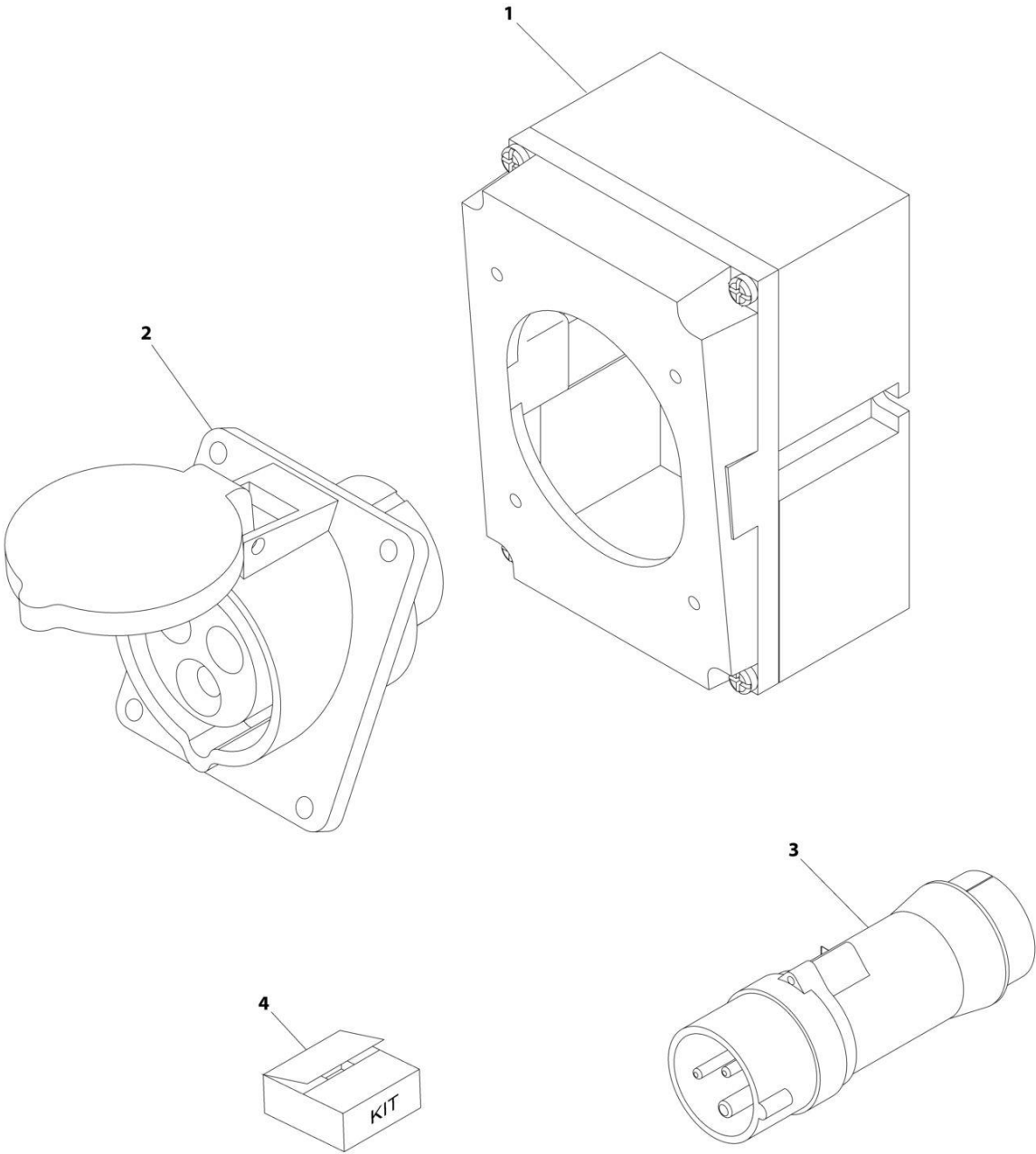

ART_0275216

SECTION 7 - ELECTRICAL

FIGURE 7-53. RECEPTACLE BOX KIT - 110V IEC YELLOW (CE & UK CA SPEC)

ITEM	PART NUMBER	QTY	DESCRIPTION	REV
	0275216	Ref	RECEPTACLE BOX KIT - 110V IEC YELLOW	B
1	0861781	1	Box, Switch	
2	4461198	1	Receptacle	
3	4461196	1	Plug, Male	
4	1001100341	1	Plug and Socket Kit (Includes Items 1-3 and Female Plug p/n 4461197)	

SECTION 7 - ELECTRICAL

FIGURE 7-54. RECEPTACLE BOX KIT - 220V IEC BLUE (CE & UK CA SPEC)

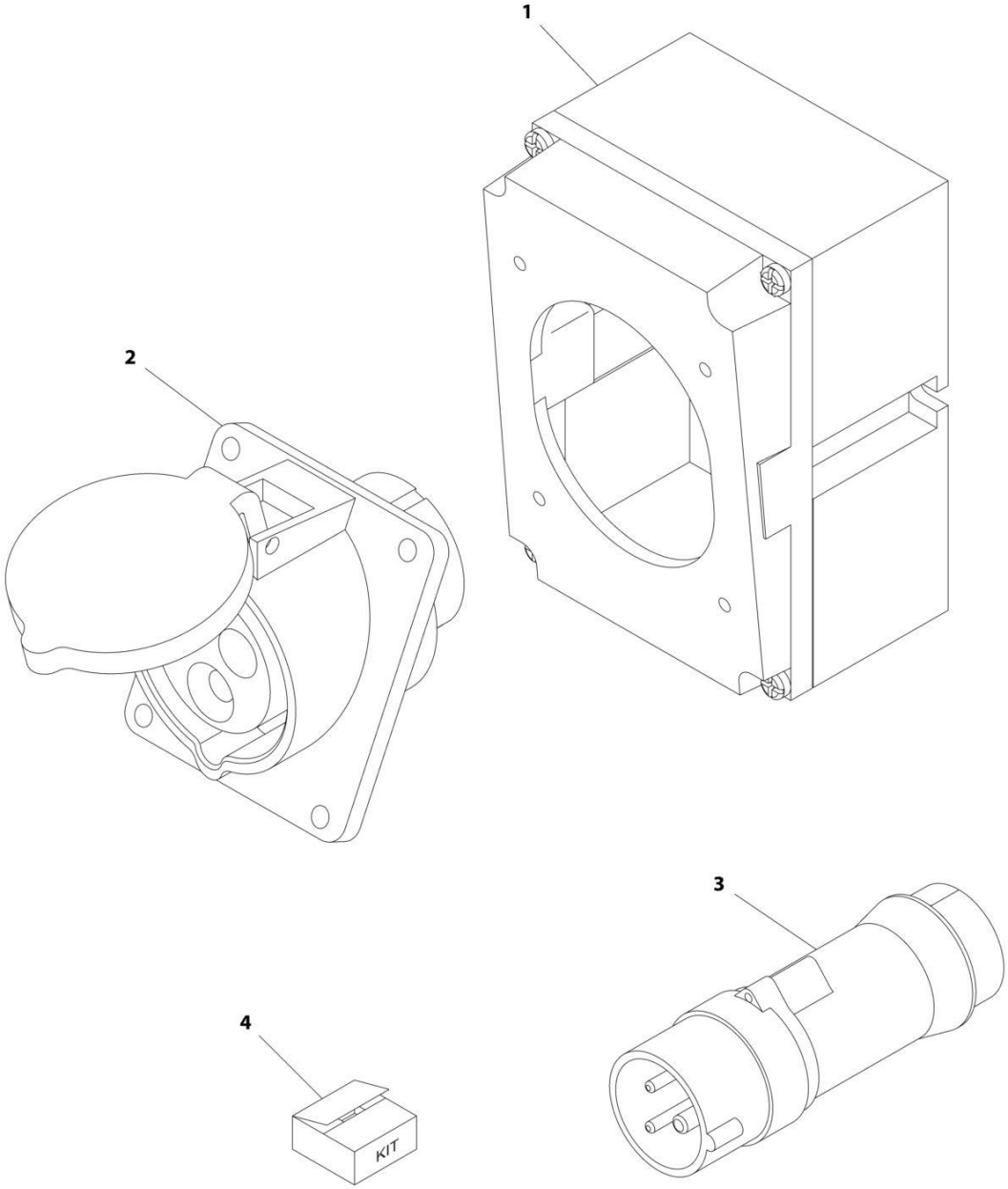

ART_0275217

SECTION 7 - ELECTRICAL

FIGURE 7-54. RECEPTACLE BOX KIT - 220V IEC BLUE (CE & UK CA SPEC)

ITEM	PART NUMBER	QTY	DESCRIPTION	REV
	0275217	Ref	RECEPTACLE BOX KIT - 220V IEC BLUE	B
1	0861781	1	Box, Switch	
2	4461201	1	Receptacle	
3	4461199	1	Plug, Male	
4	1001100342	1	Plug and Socket Kit (Includes Items 1-3 and Female Plug p/n 4461200)	

SECTION 7 - ELECTRICAL

FIGURE 7-55. RECEPTACLE BOX KIT - 220V CEE7 POST GROUND (CE & UK CA SPEC)

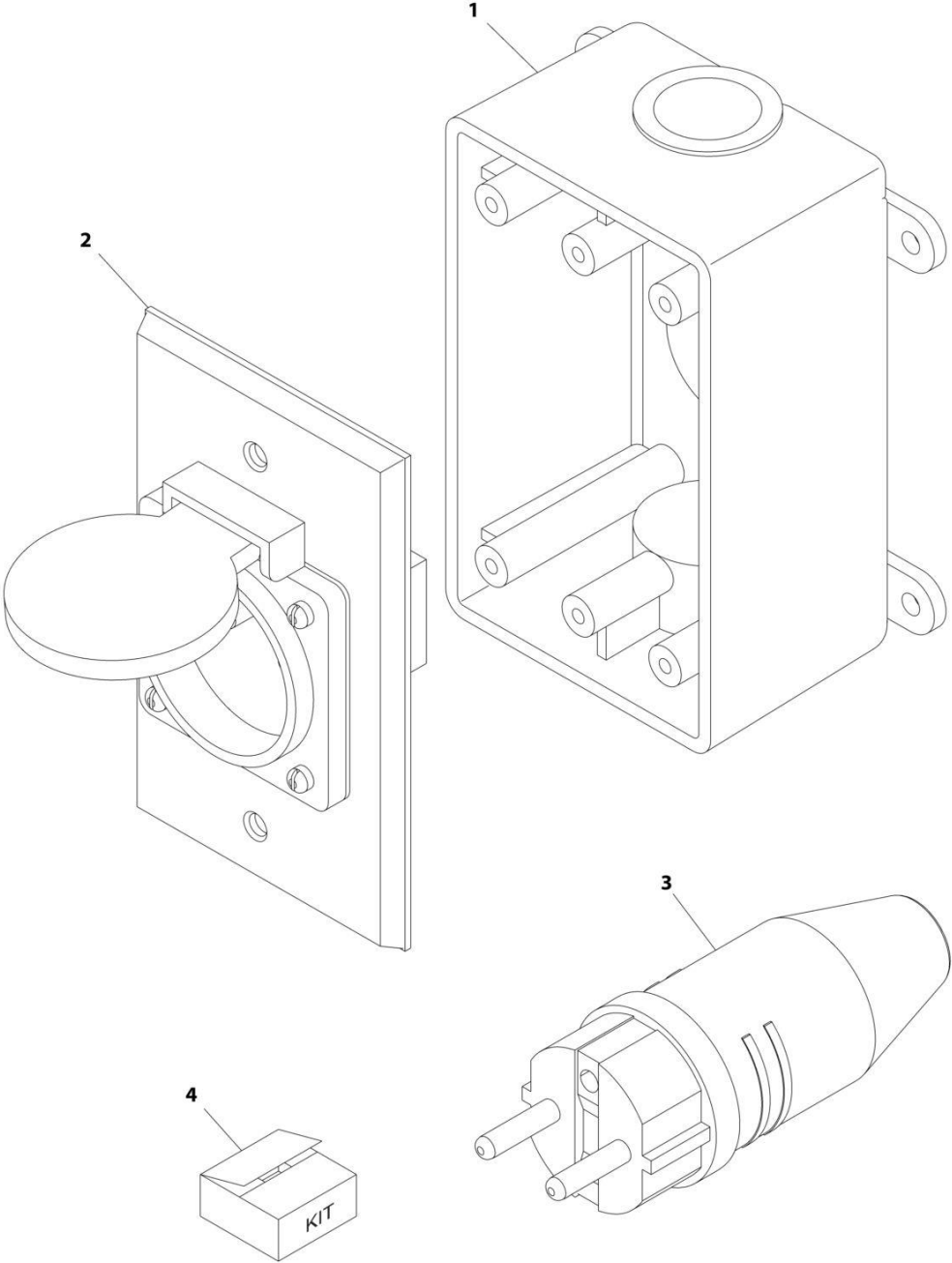

ART_0275452-C

SECTION 7 - ELECTRICAL

FIGURE 7-55. RECEPTACLE BOX KIT - 220V CEE7 POST GROUND (CE & UK CA SPEC)

ITEM	PART NUMBER	QTY	DESCRIPTION	REV
	0275452	Ref	RECEPTACLE BOX KIT - 220V CEE7 POST GROUND 2IN X 4IN BOX	C
1	0861731	1	Box, Switch	
2	4461244	1	Receptacle	
3	4461205	1	Plug, Male	
4	1001100345	1	Plug and Socket Kit (Includes Items 1-3 and Female Plug p/n 4461203)	

SECTION 7 - ELECTRICAL

FIGURE 7-56. RECEPTACLE BOX KIT - 220V CEE7 SIDE GROUND (CE & UK CA SPEC)

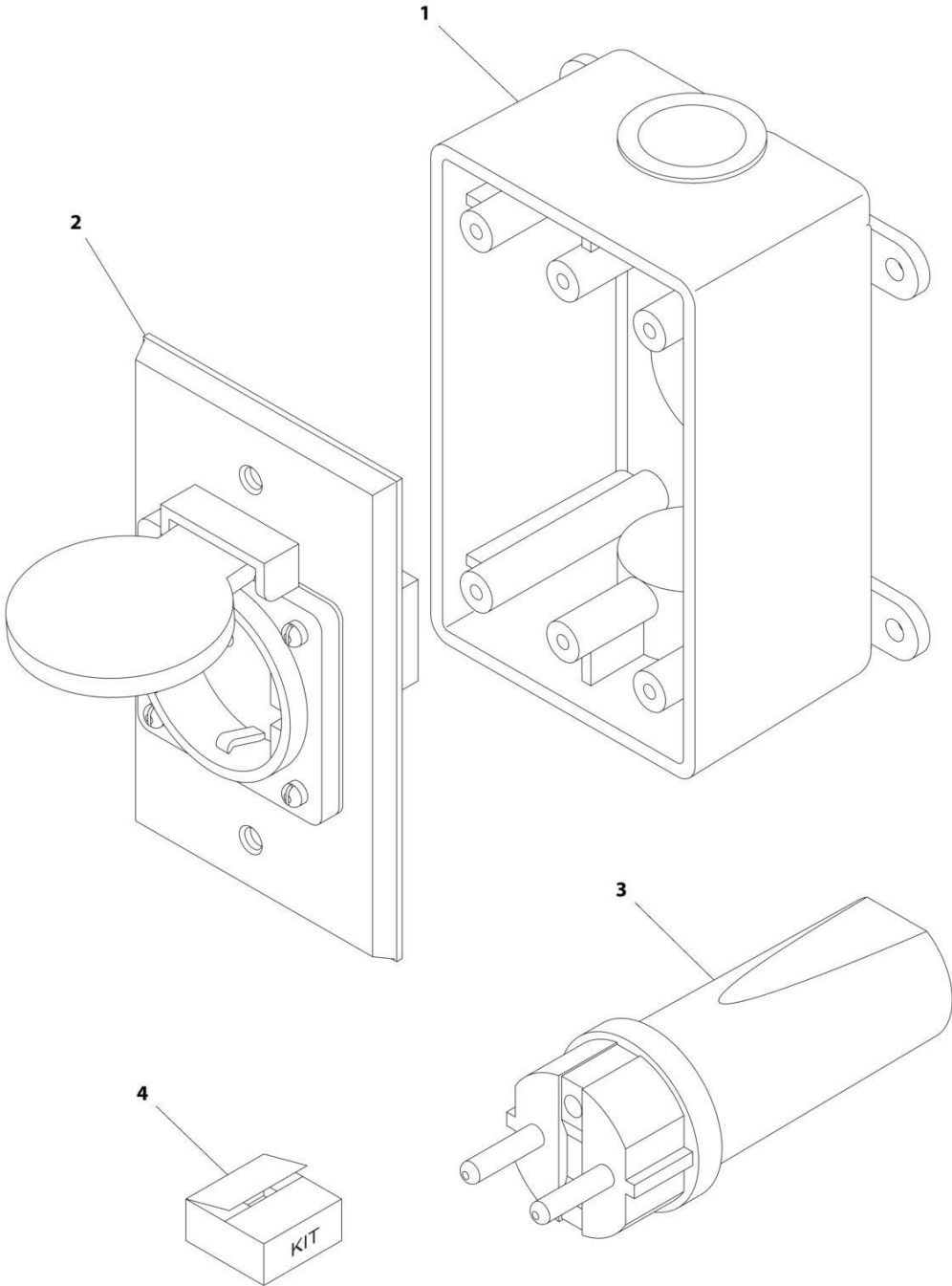

ART_0275453

SECTION 7 - ELECTRICAL

FIGURE 7-56. RECEPTACLE BOX KIT - 220V CEE7 SIDE GROUND (CE & UK CA SPEC)

ITEM	PART NUMBER	QTY	DESCRIPTION	REV
	0275453	Ref	RECEPTACLE BOX KIT - 220V CEE7 SIDE GROUND	B
1	0861731	1	Box, Switch	
2	4461245	1	Receptacle	
3	4461205	1	Plug, Male	
4	1001100347	1	Plug and Socket Kit (Includes Items 1-3 and Female Plug p/n 4461206)	

SECTION 7 - ELECTRICAL

FIGURE 7-57. RECEPTACLE BOX KIT - 220V AFSINT 107 (CE & UK CA SPEC)

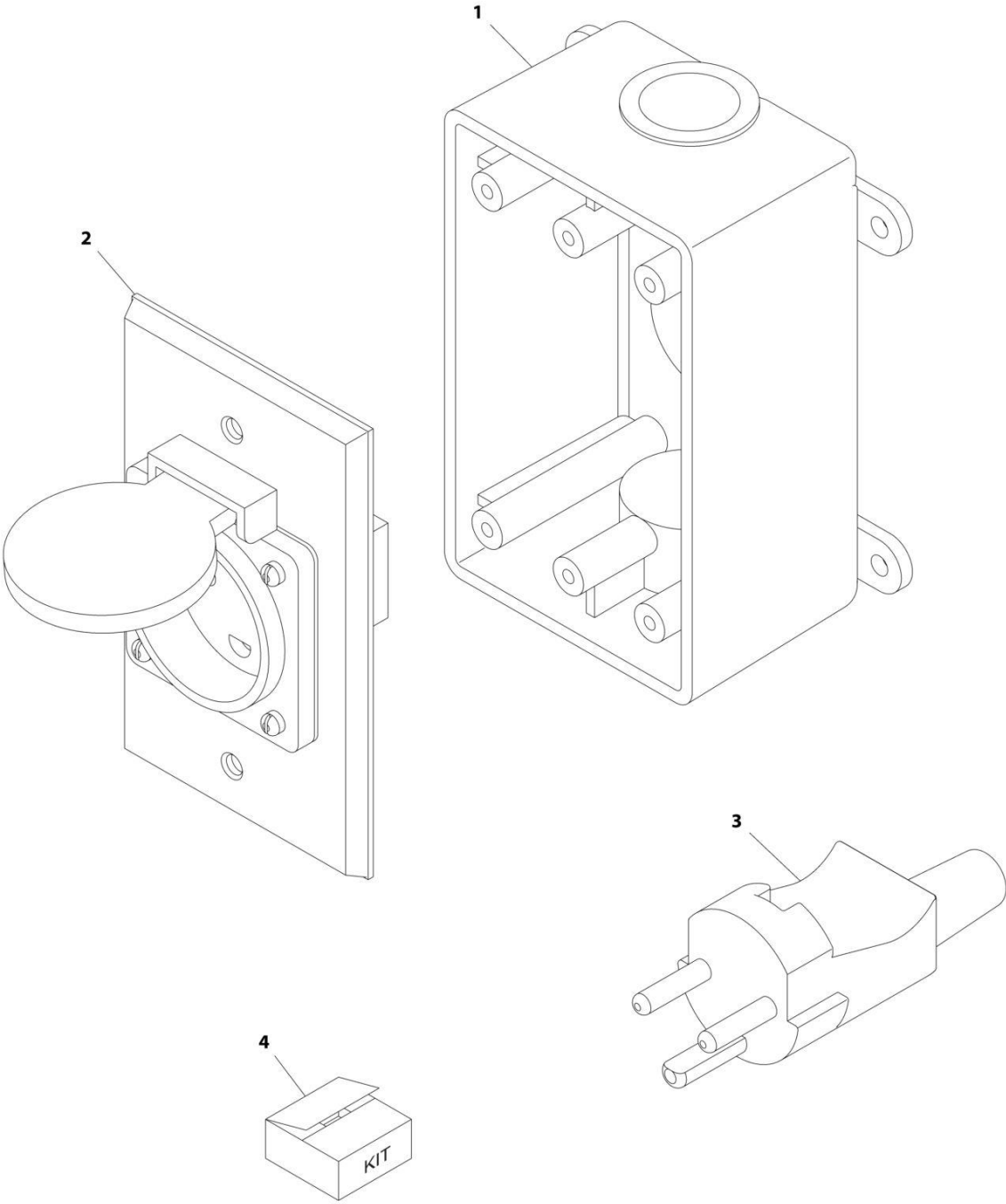

ART_0275454

SECTION 7 - ELECTRICAL

FIGURE 7-57. RECEPTACLE BOX KIT - 220V AFSINT 107 (CE & UK CA SPEC)

ITEM	PART NUMBER	QTY	DESCRIPTION	REV
	0275454	Ref	RECEPTACLE BOX KIT - 220V AFSINT 107	B
1	0861731	1	Box, Switch	
2	4461246	1	Receptacle	
3	4461249	1	Plug, Male	
4	1001100346	1	Plug and Socket Kit (Includes Items 1-3 and Female Plug p/n 4461250)	

SECTION 7 - ELECTRICAL

FIGURE 7-58. WORKLIGHT CABLE

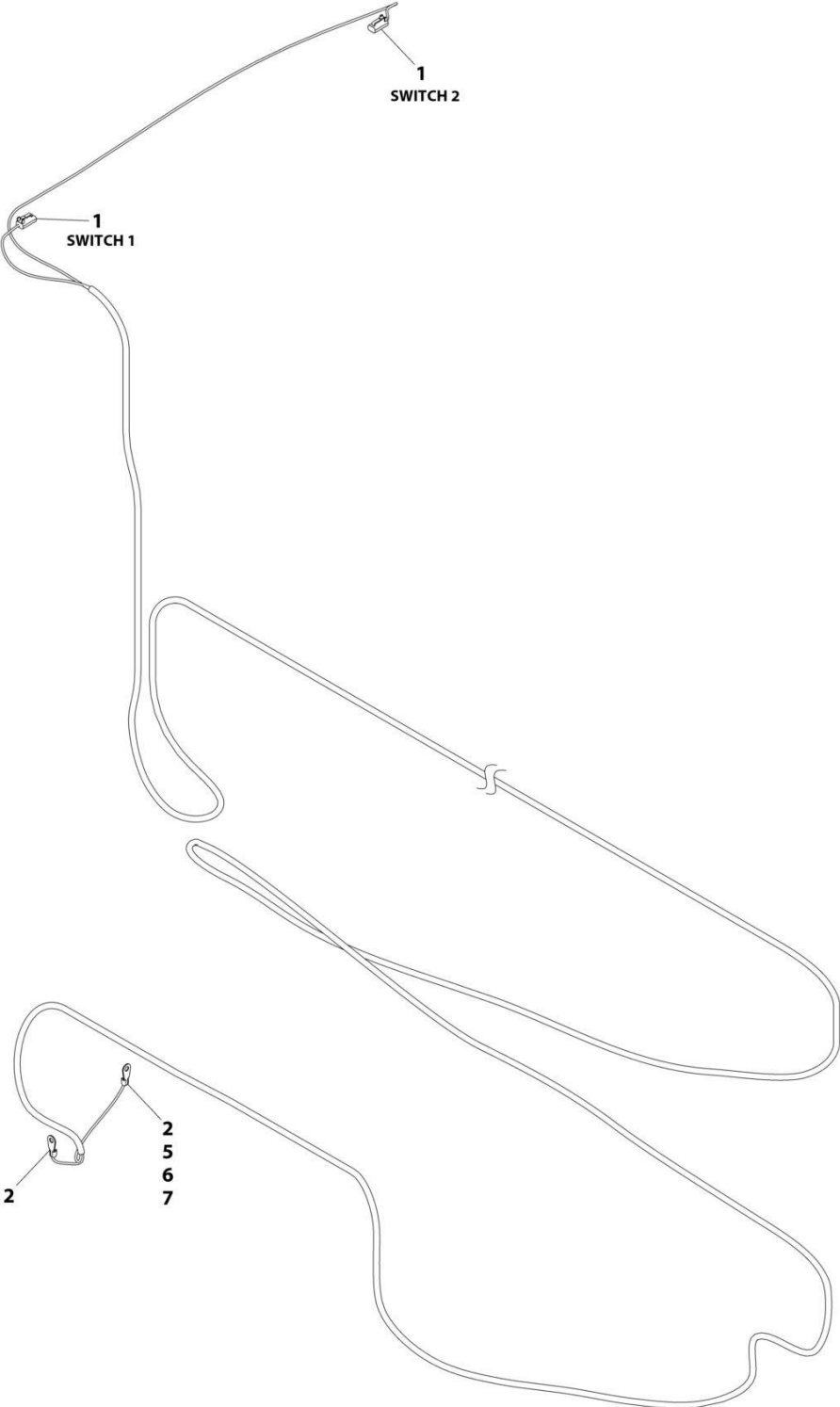

ART_1061041

SECTION 7 - ELECTRICAL

FIGURE 7-58. WORKLIGHT CABLE

ITEM	PART NUMBER	QTY	DESCRIPTION	REV
	1061041	Ref	CABLE WORKLIGHT	C
1	4460891	2	Plug, Male - 2 Position	
2	4460986	2	Terminal, Ring	
3	4460465	4	Socket (Not Shown)	
5	4460018	1	Connector, Butt Splice	
6	2400061	1	Fuse	
7	2400066	1	Fuse Holder	

SECTION 8 - DECALS

SECTION 8 - DECALS

FIGURE 8-1. DECAL INSTALLATION (ANSI SPEC)

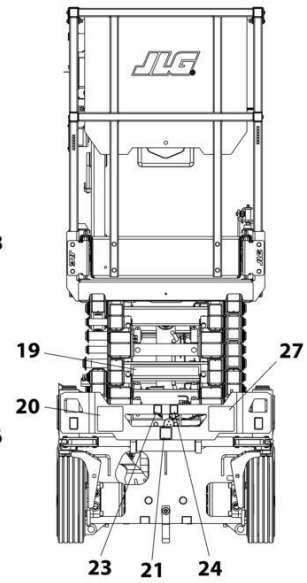
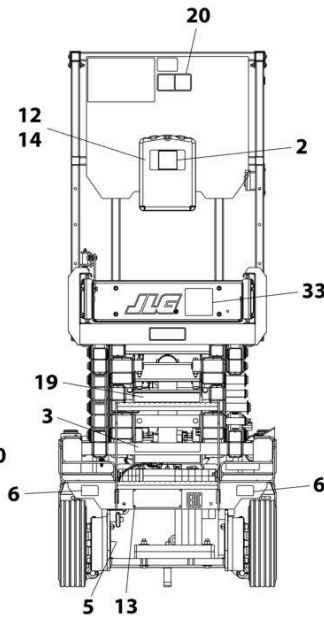
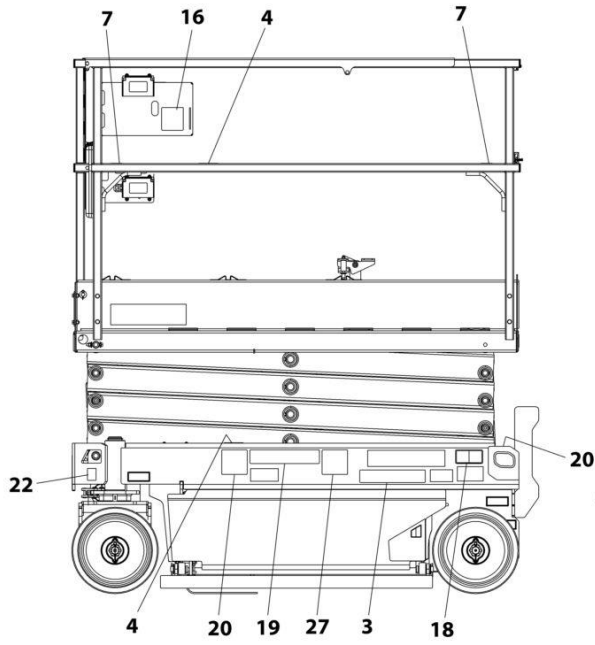

REAR VIEW - FIXED RAILS
(LADDER AND PLATFORM BOX
REMOVED FOR CLARITY)

FRONT VIEW

NOTE: ITEMS SHOWN MAY NOT BE REQUIRED FOR ALL SPECS. REFER TO PARTS LISTS FOR USAGE.

NOTE: ADDITIONAL DECALS CALLED OUT ON DECAL INSTALLATION - OPTIONS.

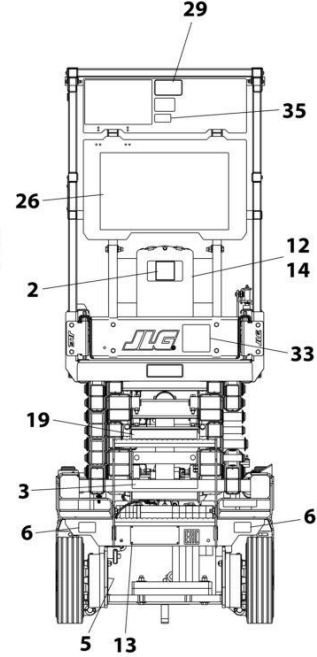
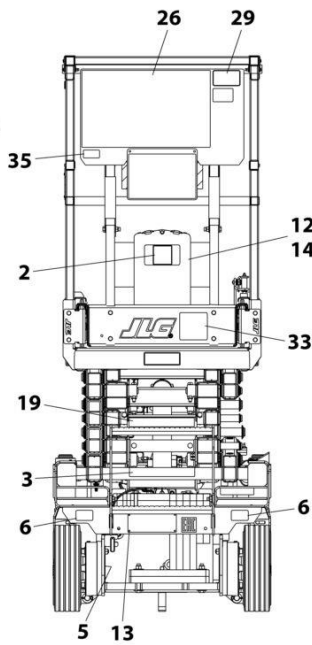
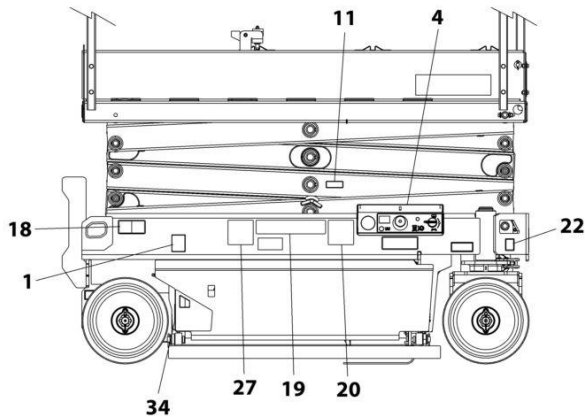

REAR VIEW - FOLD-DOWN RAILS
(LADDER AND PLATFORM BOX REMOVED FOR CLARITY)

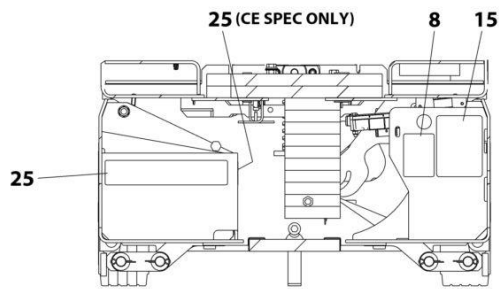

DETAIL OF COMPONENTS
INSIDE FRAME TRAYS

ART_1001209907_E

SECTION 8 - DECALS

FIGURE 8-1. DECAL INSTALLATION (ANSI SPEC)

ITEM	PART NUMBER	QTY	DESCRIPTION	REV
	1001209907	Ref	DECAL INSTALLATION	E
	1001257773	Ref	DECAL CHART DRAWING	G
1	1701504	1	Decal - Hydraulic Oil	
2	1701640	1	Decal - Manual	
3	1703813	2	Decal - Warning Battery Ventilation	
4	1703819	4	Decal - Direction Arrow	
5	1703822	1	Decal - Manual Descent Instruction	
6	1704016	2	Decal - Fork Lift	
7	1704277	2	Decal - Lanyard Attach	
8	1704412	1	Decal - Hydraulic Oil	
11	1001220430	1	Decal - Safety Prop	
12	2080040	3	Fastener	
13	2080057	4	Fastener	
14	8990147	1	Holder, Manual	
15	1001131270	1	Decal - Patent	
16	1001132359	1	Decal - Control Box Locate	
18	1001162864	2	Decal - Lift Up/Tie Down	
19	1001211777	4	Decal - Crushing Hazard	
20	1001211779	4	Decal - Electrocution	
21	1001212290	1	Decal - Tie Down	
22	1001212291	2	Decal - Lifting Lug	
23	1001212292	1	Decal - No Lifting	
24	1001212293	1	Decal - No Forklift	
25	1001146794	1	Decal - Battery/Charger Service	
26	1703816	1	Decal - Danger/Warning	
29	1001231801	1	Decal - Prop 65 Warning	
34	1001223055	1	Decal - Yearly Inspection	
35	1001228370	1	Decal - ICES	

SECTION 8 - DECALS

FIGURE 8-2. DECAL INSTALLATION (AUSTRALIAN SPECS)

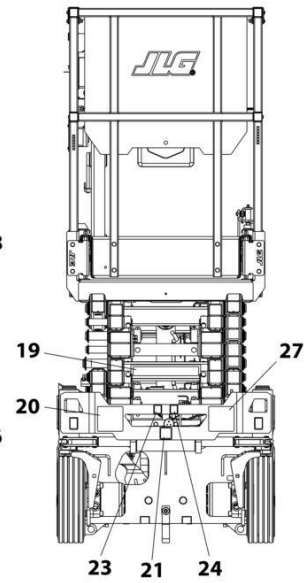
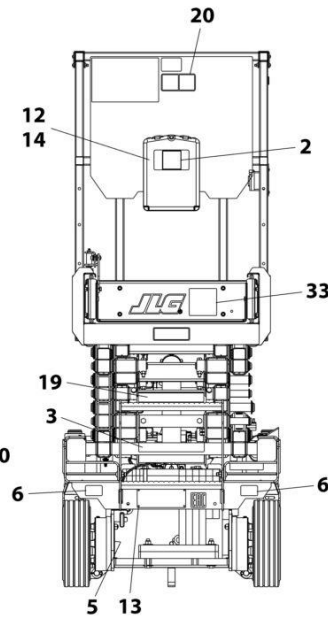
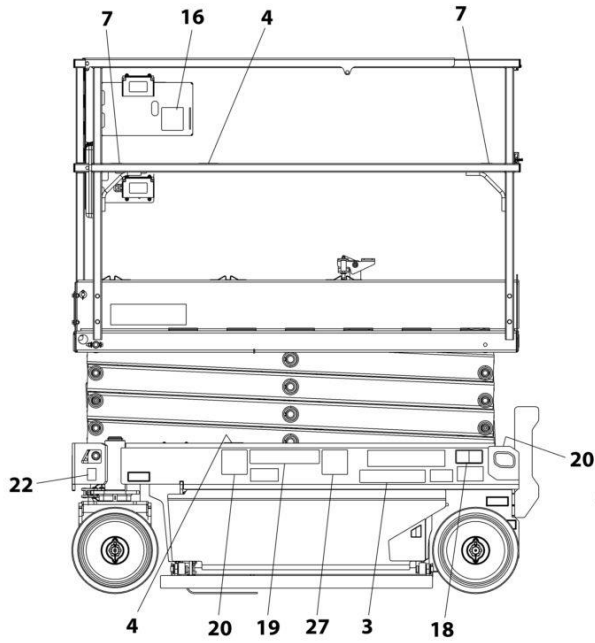

REAR VIEW - FIXED RAILS
(LADDER AND PLATFORM BOX
REMOVED FOR CLARITY)

FRONT VIEW

NOTE: ITEMS SHOWN MAY NOT BE REQUIRED FOR ALL SPECS. REFER TO PARTS LISTS FOR USAGE.

NOTE: ADDITIONAL DECALS CALLED OUT ON DECAL INSTALLATION - OPTIONS.

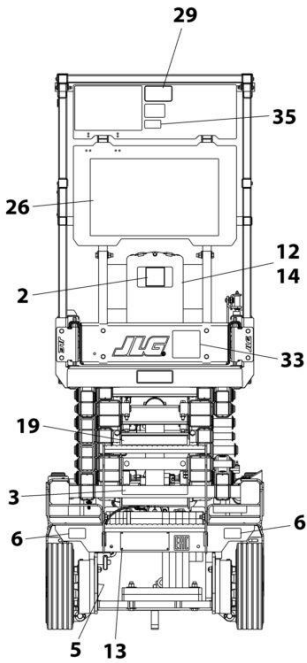
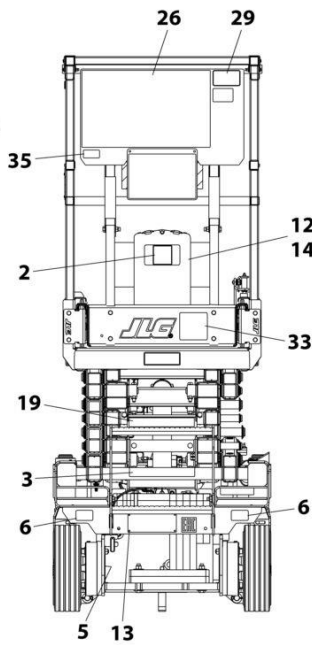
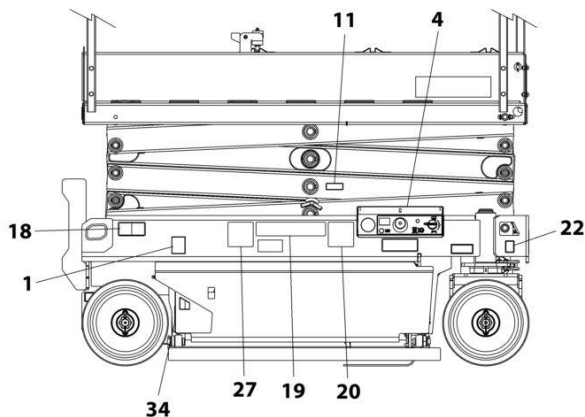

REAR VIEW - FOLD-DOWN RAILS
(LADDER AND PLATFORM BOX REMOVED FOR CLARITY)

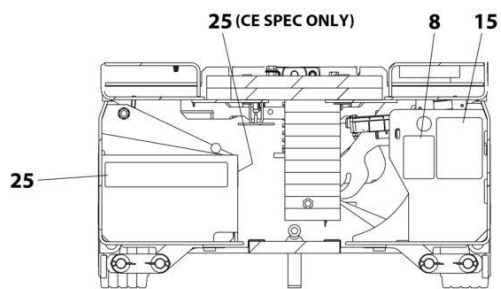

DETAIL OF COMPONENTS
INSIDE FRAME TRAYS

ART_1001209914_D

SECTION 8 - DECALS

FIGURE 8-2. DECAL INSTALLATION (AUSTRALIAN SPECS)

ITEM	PART NUMBER	QTY	DESCRIPTION	REV
	1001209914	Ref	DECAL INSTALLATION	D
	1001257773	Ref	DECAL CHART DRAWING	G
1	1701504	1	Decal - Hydraulic Oil	
2	1701640	1	Decal - Manual	
3	1705670	2	Decal - Fire Hazard	
4	1703819	4	Decal - Direction Arrow	
5	1703822	1	Decal - Manual Descent Instruction	
6	1704016	2	Decal - Fork Lift	
7	1704277	2	Decal - Lanyard Attach	
8	1704412	1	Decal - Hydraulic Oil	
11	1001220430	1	Decal - Safety Prop	
12	2080040	3	Fastener	
13	2080057	4	Fastener	
14	8990147	1	Holder, Manual	
16	1001132359	1	Decal - Control Box Locate	
18	1001162864	2	Decal - Lift Up/Tie Down	
19	1001219172	4	Decal - Crushing	
20	1001219171	5	Decal - Electrocutation	
21	1001212290	1	Decal - Tie Down	
22	1001212291	2	Decal - Lifting Lug	
23	1001212292	1	Decal - No Lifting	
24	1001212293	1	Decal - No Forklift	
25	1001146794	1	Decal - Battery/Charger Service	

SECTION 8 - DECALS

FIGURE 8-3. DECAL INSTALLATION (BRAZIL SPECS)

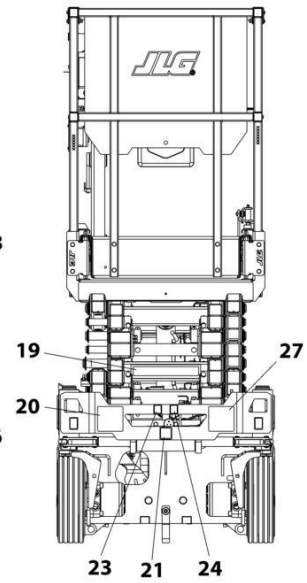
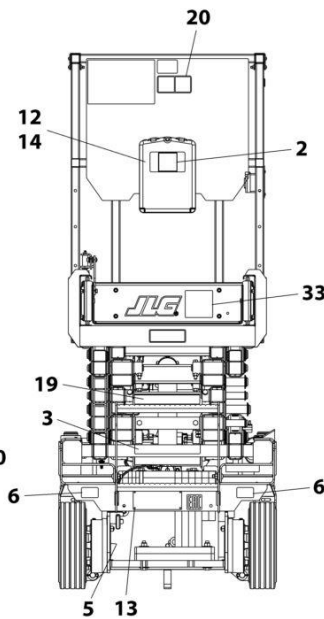
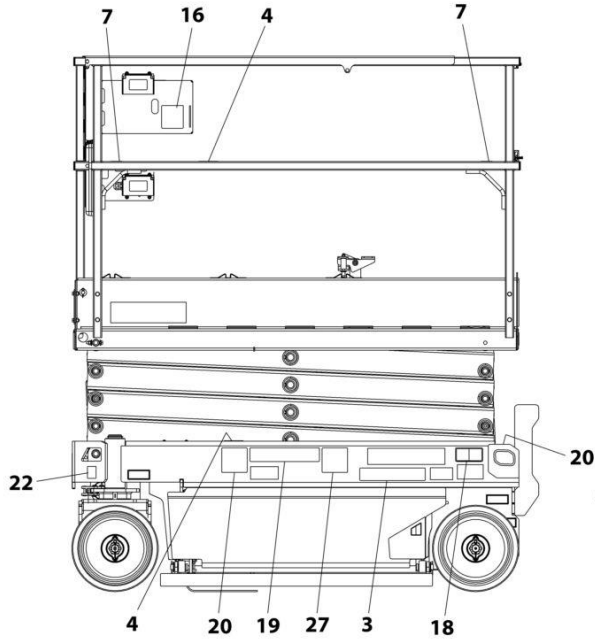

REAR VIEW - FIXED RAILS
(LADDER AND PLATFORM BOX
REMOVED FOR CLARITY)

FRONT VIEW

NOTE: ITEMS SHOWN MAY NOT BE REQUIRED FOR ALL SPECS. REFER TO PARTS LISTS FOR USAGE.

NOTE: ADDITIONAL DECALS CALLED OUT ON DECAL INSTALLATION - OPTIONS.

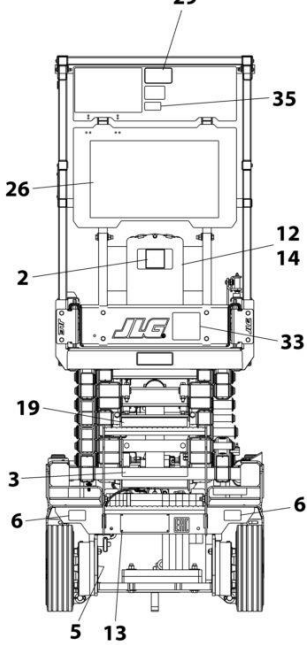
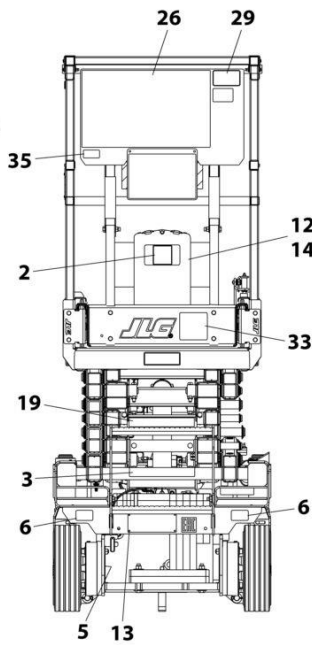
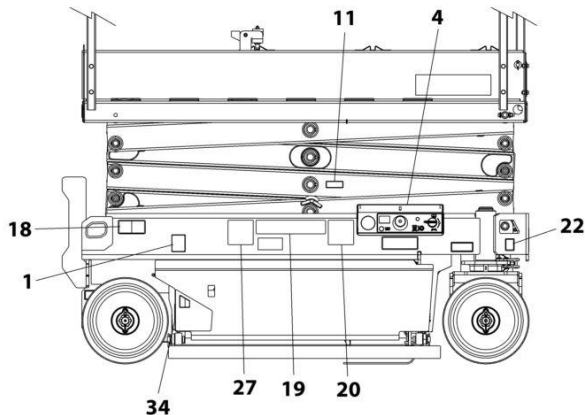

REAR VIEW - FOLD-DOWN RAILS
(LADDER AND PLATFORM BOX REMOVED FOR CLARITY)

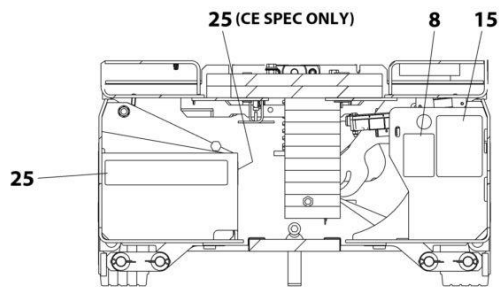

DETAIL OF COMPONENTS
INSIDE FRAME TRAYS

ART_1001209910_C

SECTION 8 - DECALS

FIGURE 8-3. DECAL INSTALLATION (BRAZIL SPECS)

ITEM	PART NUMBER	QTY	DESCRIPTION	REV
	1001209910	Ref	DECAL INSTALLATION	C
	1001257773	Ref	DECAL CHART DRAWING	G
1	1701504	1	Decal - Hydraulic Oil	
2	1701640	1	Decal - Manual	
3	1704341	2	Decal - Warning Battery Ventilation	
4	1703819	4	Decal - Direction Arrow	
5	1703822	1	Decal - Manual Descent Instruction	
6	1704016	2	Decal - Fork Lift	
7	1704277	2	Decal - Lanyard Attach	
8	1704412	1	Decal - Hydraulic Oil	
11	1001220430	1	Decal - Safety Prop	
12	2080040	3	Fastener	
13	2080057	4	Fastener	
14	8990147	1	Holder, Manual	
16	1001132359	1	Decal - Control Box Locate	
18	1001162864	2	Decal - Lift Up/Tie Down	
19	1001216650	4	Decal - Crushing Hazard	
20	1001215748	4	Decal - Danger Electrocution	
21	1001212290	1	Decal - Tie Down	
22	1001212291	2	Decal - Lifting Lug	
23	1001212292	1	Decal - No Lifting	
24	1001212293	1	Decal - No Forklift	
25	1001146794	1	Decal - Battery/Charger Service	
26	1704699	1	Decal - Danger/Warning	
27	1001216648	4	Decal - Danger Electrocution	
34	1001224052	1	Decal - Yearly Inspection	

SECTION 8 - DECALS

FIGURE 8-4. DECAL INSTALLATION (CE & UK CA SPECS)

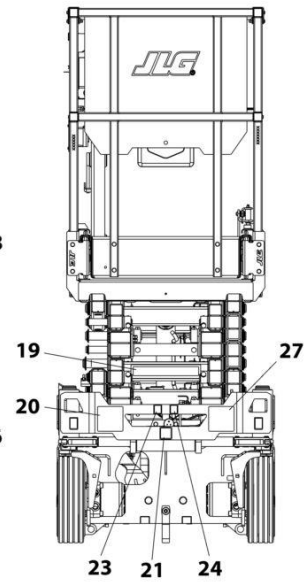
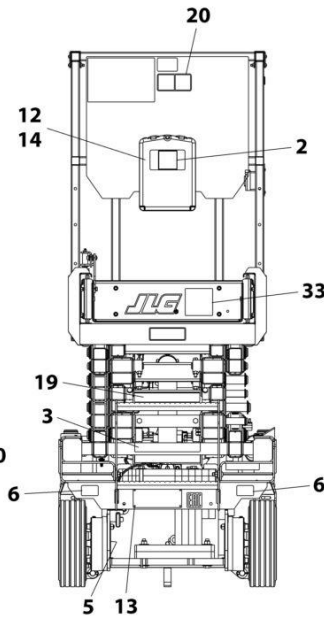
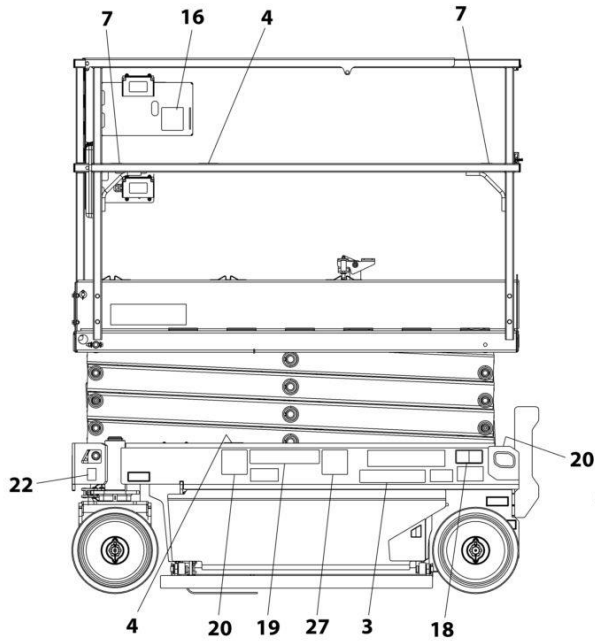

REAR VIEW - FIXED RAILS
(LADDER AND PLATFORM BOX
REMOVED FOR CLARITY)

FRONT VIEW

NOTE: ITEMS SHOWN MAY NOT BE REQUIRED FOR ALL SPECS. REFER TO PARTS LISTS FOR USAGE.

NOTE: ADDITIONAL DECALS CALLED OUT ON DECAL INSTALLATION - OPTIONS.

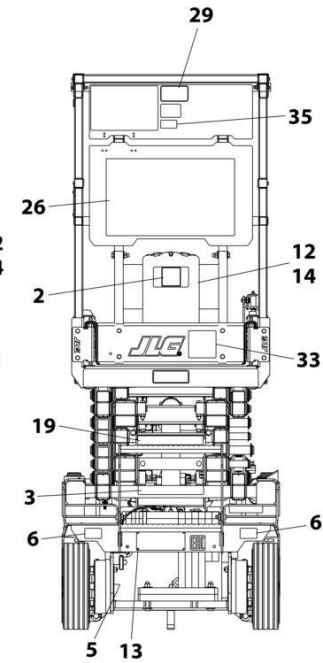
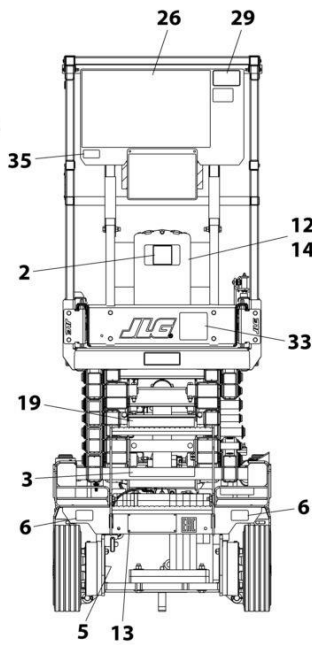
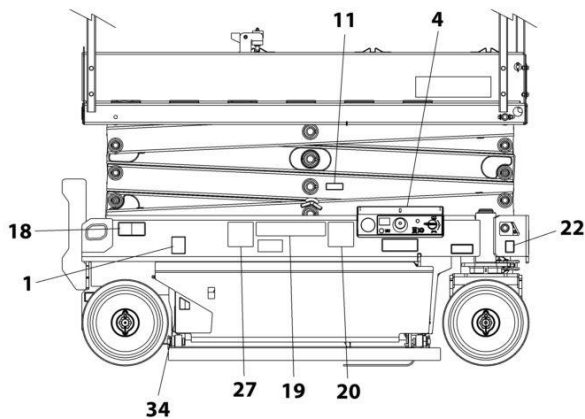

REAR VIEW - FOLD-DOWN RAILS
(LADDER AND PLATFORM BOX REMOVED FOR CLARITY)

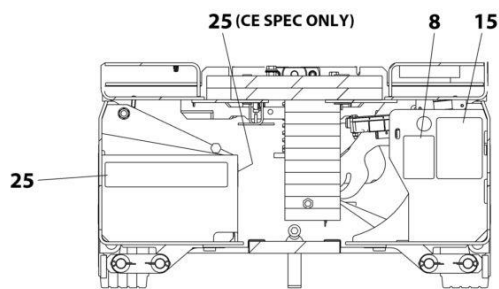

DETAIL OF COMPONENTS
INSIDE FRAME TRAYS

ART_1001209913_D

SECTION 8 - DECALS

FIGURE 8-4. DECAL INSTALLATION (CE & UK CA SPECS)

ITEM	PART NUMBER	QTY	DESCRIPTION	REV
	1001209913	Ref	DECAL INSTALLATION	D
	1001257773	Ref	DECAL CHART DRAWING	G
1	1701504	1	Decal - Hydraulic Oil	
2	1701640	1	Decal - Manual	
3	1704340	2	Decal - Warning Battery Ventilation	
4	1703819	4	Decal - Direction Arrow	
5	1703822	1	Decal - Manual Descent Instruction	
6	1704016	2	Decal - Fork Lift	
7	1704277	2	Decal - Lanyard Attach	
8	1704412	1	Decal - Hydraulic Oil	
11	1001220430	1	Decal - Safety Prop	
12	2080040	3	Fastener	
13	2080057	4	Fastener	
14	8990147	1	Holder, Manual	
16	1001132359	1	Decal - Control Box Locate	
18	1001162864	2	Decal - Lift Up/Tie Down	
19	1001215755	4	Decal - Crushing	
20	1001211779	4	Decal - Electrocutation	
21	1001212290	1	Decal - Tie Down	
22	1001212291	2	Decal - Lifting Lug	
23	1001212292	1	Decal - No Lifting	
24	1001212293	1	Decal - No Forklift	
25	1001146794	1	Decal - Battery/Charger Service	
26	1704684	1	Decal - Danger/Warning	
27	1001215749	4	Decal - Danger Electrocutation	
34	1001223971	1	Decal - Yearly Inspection	
35	1001228370	1	Decal - ICES	

SECTION 8 - DECALS

FIGURE 8-5. DECAL INSTALLATION (CHINA SPECS)

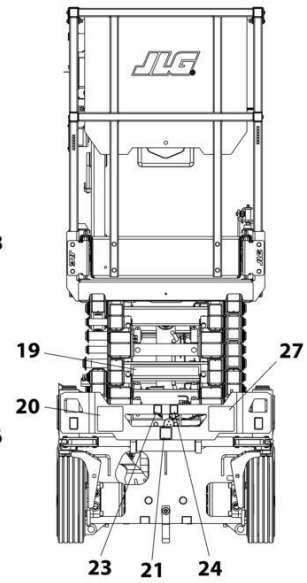
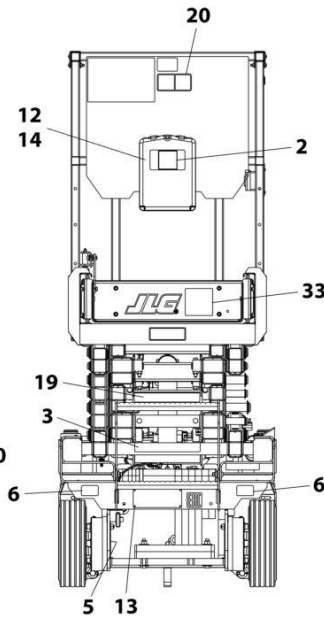
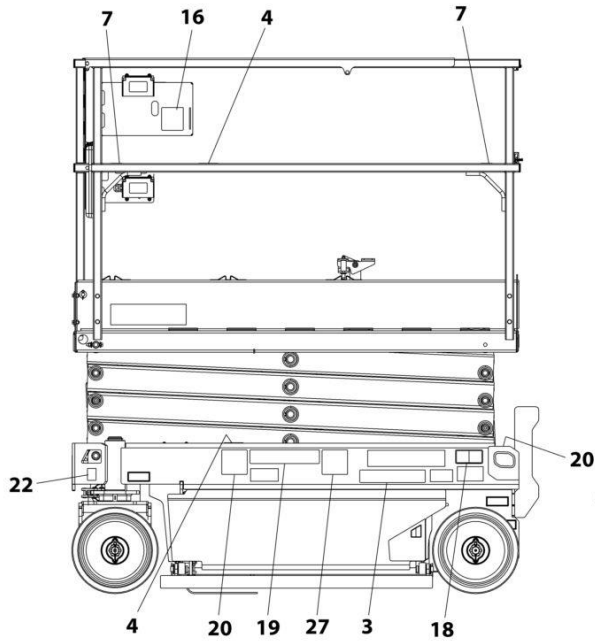

REAR VIEW - FIXED RAILS
(LADDER AND PLATFORM BOX
REMOVED FOR CLARITY)

FRONT VIEW

NOTE: ITEMS SHOWN MAY NOT BE REQUIRED FOR ALL SPECS. REFER TO PARTS LISTS FOR USAGE.

NOTE: ADDITIONAL DECALS CALLED OUT ON DECAL INSTALLATION - OPTIONS.

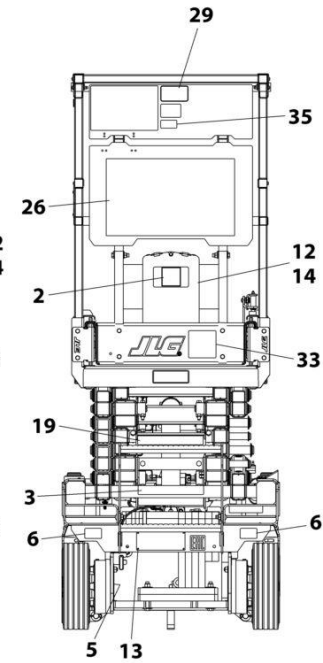
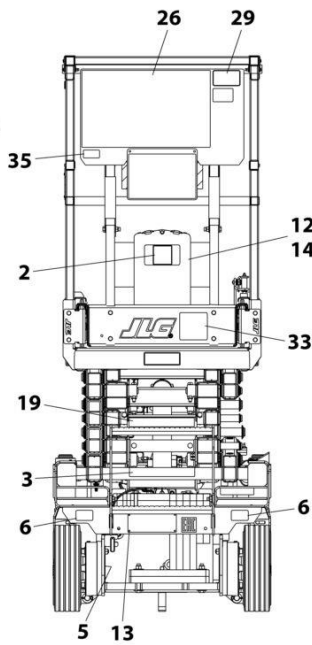
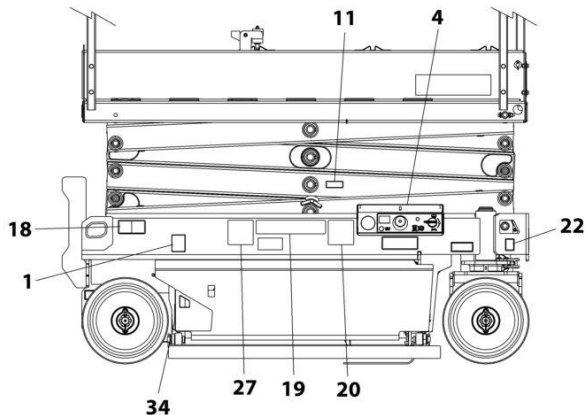

REAR VIEW - FOLD-DOWN RAILS
(LADDER AND PLATFORM BOX REMOVED FOR CLARITY)

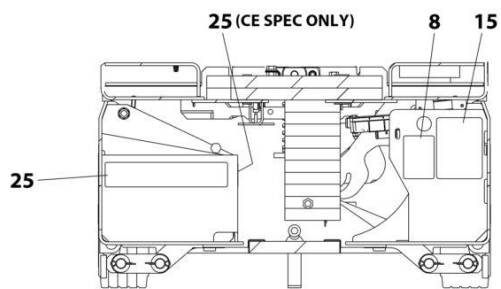

DETAIL OF COMPONENTS
INSIDE FRAME TRAYS

ART_1001209909_E

SECTION 8 - DECALS

FIGURE 8-5. DECAL INSTALLATION (CHINA SPECS)

ITEM	PART NUMBER	QTY	DESCRIPTION	REV
	1001209909	Ref	DECAL INSTALLATION	E
	1001257773	Ref	DECAL CHART DRAWING	G
1	1701504	1	Decal - Hydraulic Oil	
2	1701640	1	Decal - Manual	
3	1704344	2	Decal - Warning Battery Ventilation	
4	1703819	4	Decal - Direction Arrow	
5	1703822	1	Decal - Manual Descent Instruction	
6	1704016	2	Decal - Fork Lift	
7	1704277	2	Decal - Lanyard Attach	
8	1704412	1	Decal - Hydraulic Oil	
11	1001220430	1	Decal - Safety Prop	
12	2080040	5	Fastener	
13	2080057	4	Fastener	
14	8990147	1	Holder, Manual	
16	1001132359	1	Decal - Control Box Locate	
18	1001162864	2	Decal - Lift Up/Tie Down	
19	1001215752	4	Decal - Crushing Hazard	
20	1001211779	4	Decal - Electrocutation	
21	1001212290	1	Decal - Tie Down	
22	1001212291	2	Decal - Lifting Lug	
23	1001212292	1	Decal - No Lifting	
24	1001212293	1	Decal - No Forklift	
25	1001146794	1	Decal - Battery/Charger Service	
26	1705195	1	Decal - Danger/Warning	
27	1001215747	4	Decal - Danger Electrocutation	
33	1001244298	2	Decal - Wechat	
34	1001224051	1	Decal - Yearly Inspection	

SECTION 8 - DECALS

FIGURE 8-6. DECAL INSTALLATION (CSA SPECS)

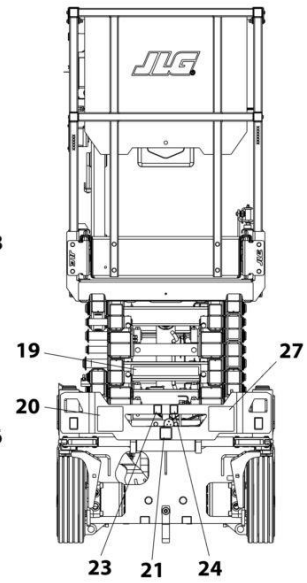
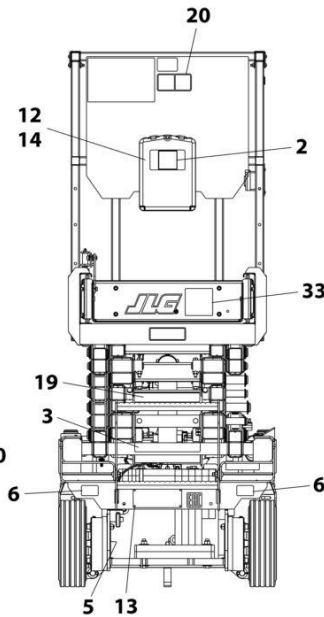
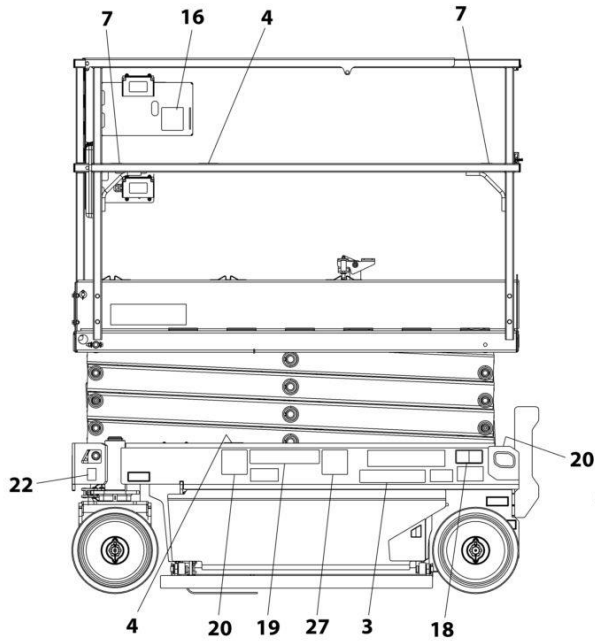

REAR VIEW - FIXED RAILS
(LADDER AND PLATFORM BOX
REMOVED FOR CLARITY)

FRONT VIEW

NOTE: ITEMS SHOWN MAY NOT BE REQUIRED FOR ALL SPECS. REFER TO PARTS LISTS FOR USAGE.

NOTE: ADDITIONAL DECALS CALLED OUT ON DECAL INSTALLATION - OPTIONS.

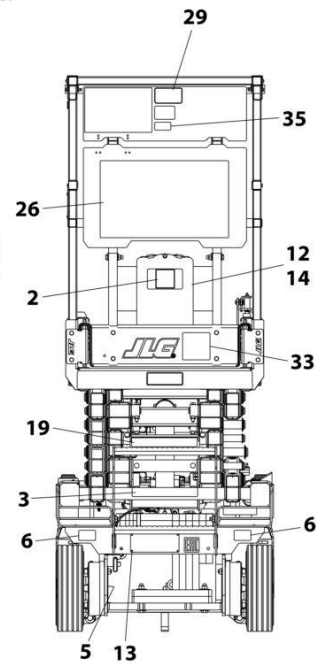
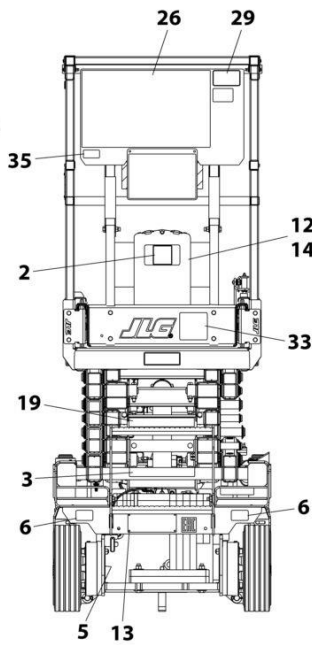
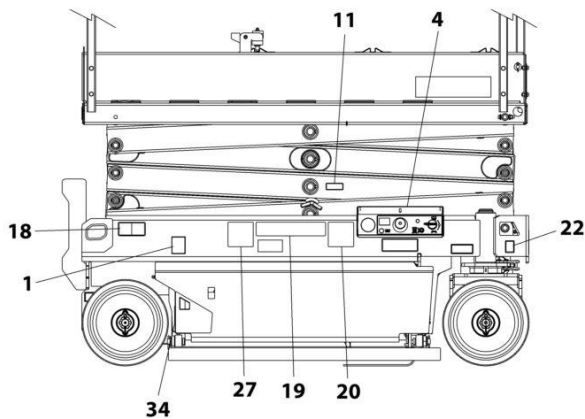

REAR VIEW - FOLD-DOWN RAILS
(LADDER AND PLATFORM BOX REMOVED FOR CLARITY)

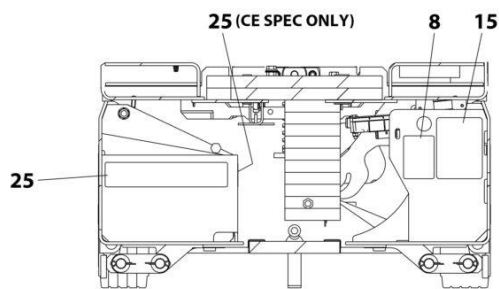

DETAIL OF COMPONENTS
INSIDE FRAME TRAYS

ART_1001219265_C

SECTION 8 - DECALS

FIGURE 8-6. DECAL INSTALLATION (CSA SPECS)

ITEM	PART NUMBER	QTY	DESCRIPTION	REV
	1001219265	Ref	DECAL INSTALLATION	C
	1001257773	Ref	DECAL CHART DRAWING	G
1	1701504	1	Decal - Hydraulic Oil	
2	1701640	1	Decal - Manual	
3	1704340	2	Decal - Warning Battery Ventilation	
4	1703819	4	Decal - Direction Arrow	
5	1703822	1	Decal - Manual Descent Instruction	
6	1704016	2	Decal - Fork Lift	
7	1704277	2	Decal - Lanyard Attach	
8	1704412	1	Decal - Hydraulic Oil	
11	1001220430	1	Decal - Safety Prop	
12	2080040	5	Fastener	
13	2080057	4	Fastener	
14	8990147	1	Holder, Manual	
15	1001131270	1	Decal - Patent	
16	1001132359	1	Decal - Control Box Locate	
18	1001162864	2	Decal - Lift Up/Tie Down	
19	1001215755	4	Decal - Crushing Hazard	
20	1001211779	4	Decal - Electrocution	
21	1001212290	1	Decal - Tie Down	
22	1001212291	2	Decal - Lifting Lug	
23	1001212292	1	Decal - No Lifting	
24	1001212293	1	Decal - No Forklift	
25	1001146794	1	Decal - Battery/Charger Service	
26	1704684	1	Decal - Danger/Warning	
27	1001215749	4	Decal - Danger Electrocution	
34	1001223971	1	Decal - Yearly Inspection	
35	1001228370	1	Decal - ICES	

SECTION 8 - DECALS

FIGURE 8-7. DECAL INSTALLATION (KOREAN SPECS)

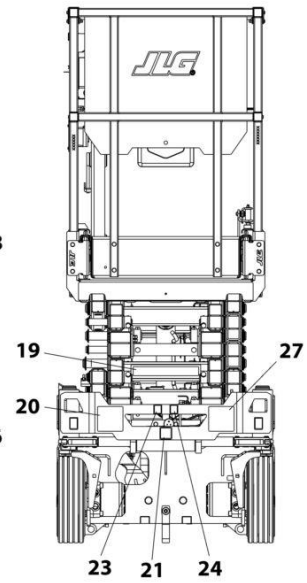
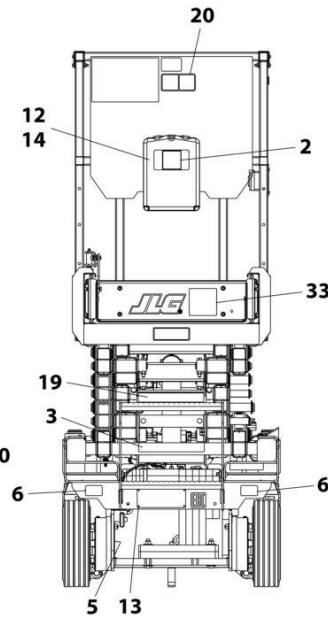

REAR VIEW - FIXED RAILS
(LADDER AND PLATFORM BOX
REMOVED FOR CLARITY)

FRONT VIEW

NOTE: ITEMS SHOWN MAY NOT BE REQUIRED FOR ALL SPECS. REFER TO PARTS LISTS FOR USAGE.

NOTE: ADDITIONAL DECALS CALLED OUT ON DECAL INSTALLATION - OPTIONS.

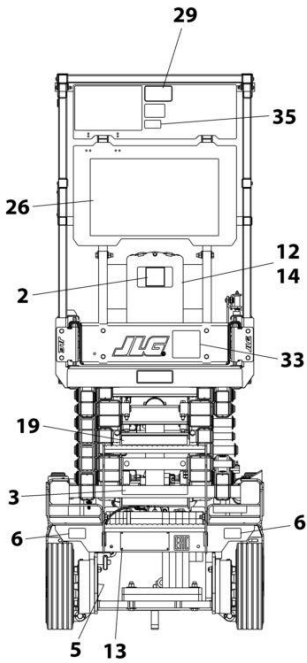
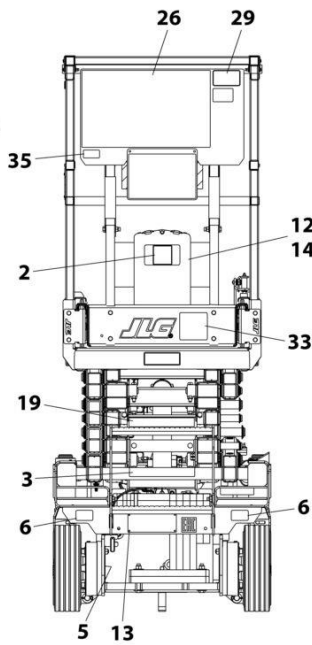
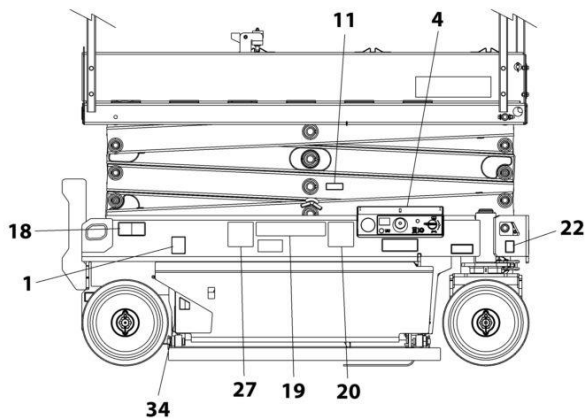

REAR VIEW - FOLD-DOWN RAILS
(LADDER AND PLATFORM BOX REMOVED FOR CLARITY)

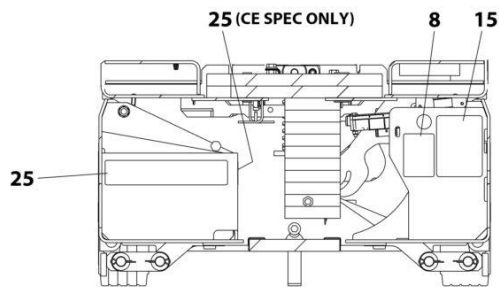

DETAIL OF COMPONENTS
INSIDE FRAME TRAYS

ART_1001209908_C

SECTION 8 - DECALS

FIGURE 8-7. DECAL INSTALLATION (KOREAN SPECS)

ITEM	PART NUMBER	QTY	DESCRIPTION	REV
	1001209908	Ref	DECAL INSTALLATION	C
	1001257773	Ref	DECAL CHART DRAWING	G
1	1701504	1	Decal - Hydraulic Oil	
2	1701640	1	Decal - Manual	
3	1707022	2	Decal - Warning Battery Ventilation	
4	1703819	4	Decal - Direction Arrow	
5	1703822	1	Decal - Manual Descent Instruction	
6	1704016	2	Decal - Fork Lift	
7	1704277	2	Decal - Lanyard Attach	
8	1704412	1	Decal - Hydraulic Oil	
11	1001220430	1	Decal - Safety Prop	
12	2080040	3	Fastener	
13	2080057	4	Fastener	
14	8990147	1	Holder, Manual	
16	1001132359	1	Decal - Control Box Locate	
18	1001162864	2	Decal - Lift Up/Tie Down	
19	1001215751	4	Decal - Crushing Hazard	
20	1001211779	4	Decal - Electrocution	
21	1001212290	1	Decal - Tie Down	
22	1001212291	2	Decal - Lifting Lug	
23	1001212292	1	Decal - No Lifting	
24	1001212293	1	Decal - No Forklift	
25	1001146794	1	Decal - Battery/Charger Service	
26	1001162115	1	Decal - Danger/Warning	
27	1001215750	4	Decal - Danger Electrocution	
28	1001224048	1	Decal - Yearly Inspection	

SECTION 8 - DECALS

FIGURE 8-8. DECAL INSTALLATION (LATIN AMERICAN SPECS)

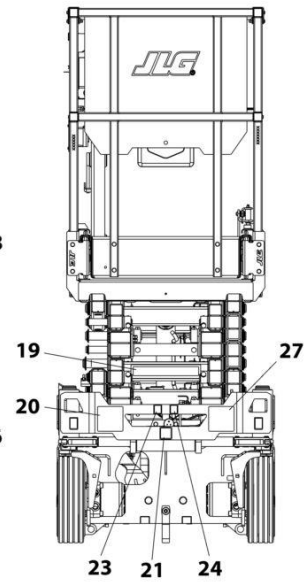
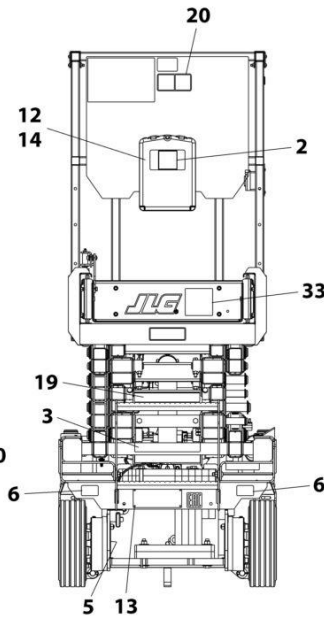
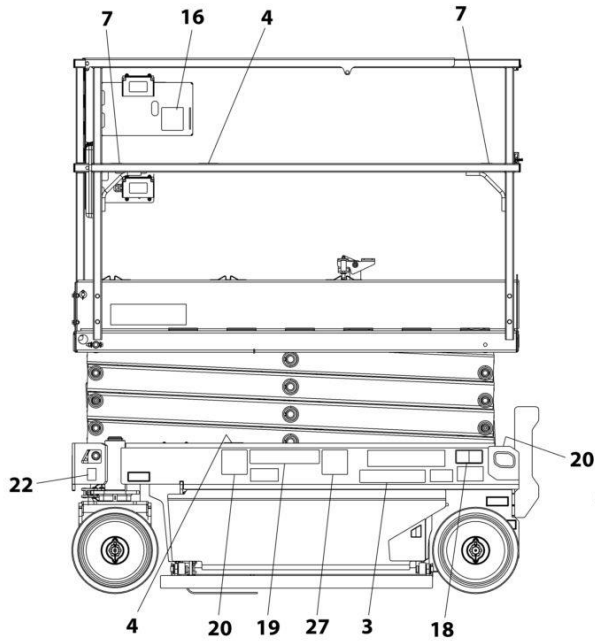

REAR VIEW - FIXED RAILS
(LADDER AND PLATFORM BOX
REMOVED FOR CLARITY)

FRONT VIEW

NOTE: ITEMS SHOWN MAY NOT BE REQUIRED FOR ALL SPECS. REFER TO PARTS LISTS FOR USAGE.

NOTE: ADDITIONAL DECALS CALLED OUT ON DECAL INSTALLATION - OPTIONS.

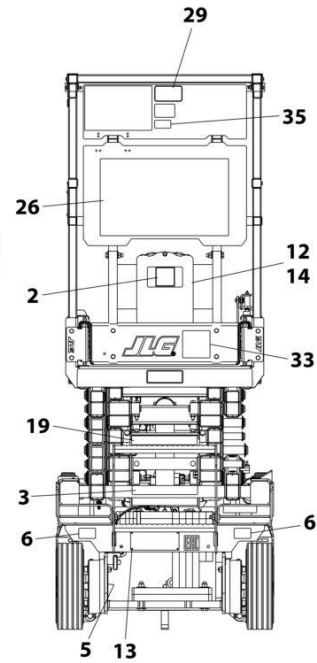
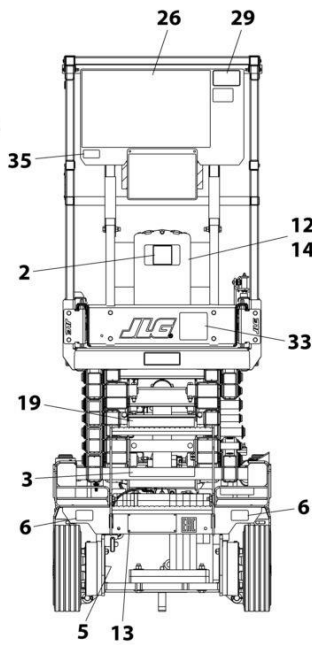
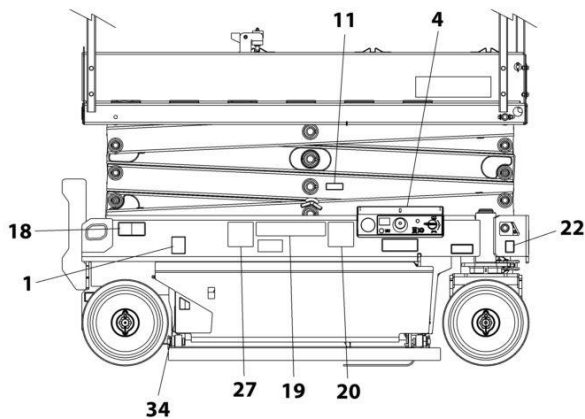

REAR VIEW - FOLD-DOWN RAILS
(LADDER AND PLATFORM BOX REMOVED FOR CLARITY)

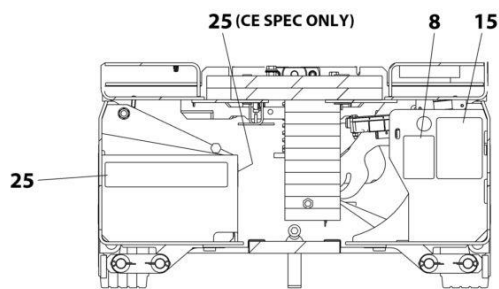

DETAIL OF COMPONENTS
INSIDE FRAME TRAYS

ART_1001209911_C

SECTION 8 - DECALS

FIGURE 8-8. DECAL INSTALLATION (LATIN AMERICAN SPECS)

ITEM	PART NUMBER	QTY	DESCRIPTION	REV
	1001209911	Ref	DECAL INSTALLATION	C
	1001257773	Ref	DECAL CHART DRAWING	G
1	1701504	1	Decal - Hydraulic Oil	
2	1701640	1	Decal - Manual	
3	1704339	2	Decal - Warning Battery Ventilation	
4	1703819	4	Decal - Direction Arrow	
5	1703822	1	Decal - Manual Descent Instruction	
6	1704016	2	Decal - Fork Lift	
7	1704277	2	Decal - Lanyard Attach	
8	1704412	1	Decal - Hydraulic Oil	
11	1001220430	1	Decal - Safety Prop	
12	2080040	3	Fastener	
13	2080057	4	Fastener	
14	8990147	1	Holder, Manual	
16	1001132359	1	Decal - Control Box Locate	
18	1001162864	2	Decal - Lift Up/Tie Down	
19	1001215754	4	Decal - Crushing Hazard	
20	1001211779	4	Decal - Electrocution	
21	1001212290	1	Decal - Tie Down	
22	1001212291	2	Decal - Lifting Lug	
23	1001212292	1	Decal - No Lifting	
24	1001212293	1	Decal - No Forklift	
25	1001146794	1	Decal - Battery/Charger Service	
26	1704691	1	Decal - Danger/Warning	
27	1001215748	4	Decal - Danger Electrocution	
34	1001224049	1	Decal - Yearly Inspection	

SECTION 8 - DECALS

FIGURE 8-9. DECAL INSTALLATION - OPTIONS

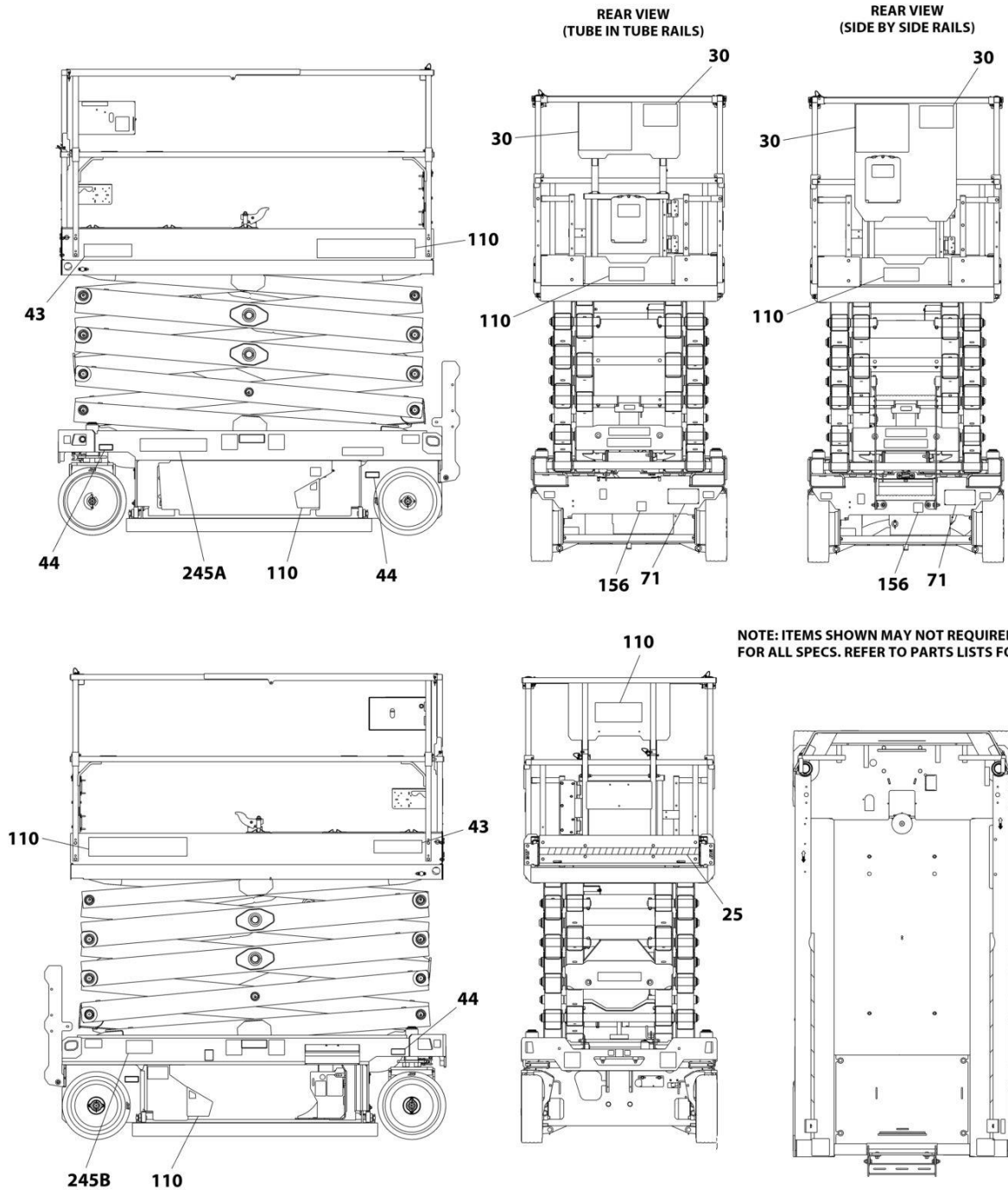

NOTE: ITEMS SHOWN MAY NOT REQUIRED FOR ALL SPECS. REFER TO PARTS LISTS FOR USAGE.

ART_DECAL_OPTIONS

SECTION 8 - DECALS

FIGURE 8-9. DECAL INSTALLATION - OPTIONS

ITEM	PART NUMBER	QTY	DESCRIPTION	REV
		Ref	DECAL INSTALLATION - OPTIONS	
25	1001209906	Ref	Corner Stripes Installation	
25	4420051	2.5 ft /75cm	Tape, Safety	
30		Ref	Decal - Capacity Options	
30	1001256175	1	Decal - Capacity (600LB/272KG) (R1532i) (All Specs)	
30	1001258899	1	Decal - Capacity (600LB/272KG) (R1532i) (ANSI Export, China, CSA and Korea Specs)	
30	1001256174	1	Decal - Capacity (507LB/230KG) (R1932i) (All Specs Except Australian Specs)	
30	1001258900	1	Decal - Capacity (507LB/230KG) (R1932i) (ANSI Export, China, CSA and Korea Specs)	
30	1001256176	1	Decal - Capacity (507LB/230KG) (R1932) (All Specs Except Japanese & Korean MOL70 Specs)	
30	1001265048	1	Decal - Capacity (507LB/230KG) (R1932) (Japanese & Korean MOL70 Specs)	
30	1001258822	1	Decal - Capacity (507LB/230KG) (R1932) (ANSI Export, China, CSA and Korea Specs)	
43		Ref	Decal - Model Designation Options:	
43	1001257171	2	Decal - R1532i	
43	1001257172	2	Decal - R1932i	
43	1001257173	2	Decal - R1932	
44		Ref	Decal - Maximum Tire Load Options:	
44	1001227703	4	Decal Maximum Tire Load - R1532i	
44	1705647	4	Decal Maximum Tire Load - R1932i	
44	1705648	4	Decal Maximum Tire Load - R1932	
71	See Note	NSS	Decal - Manufacturers Serial Number (Note: Not Available for Purchase)	
110A	1001255102	Ref	JLG Decals Installation (All Specs Except China Specs)	
110A	1001255104	1	Decal - JLG (Right)	
110A	1001255105	1	Decal - JLG (Left)	
110A	1001256675	1	Decal - JLG (3-5/16 Wide)	
110A	1001256676	1	Decal - JLG (2-5/8 Wide)	
110B	1001288509	1	Decal - JLG (With Inside Tube Sliding Platform) (China Specs)	
110B	1001255104	1	Decal - JLG (Right)	
110B	1001255105	1	Decal - JLG (Left)	
110B	1001287763	1	Decal - JLG Gate	
110B	1001288431	2	Decal - JLG Platform	
110B	1001288434	1	Decal - JLG Billboard	
110C	1001288510	1	Decal - JLG (With Outside Tube Sliding Platform) (China Specs)	
110C	1001255104	1	Decal - JLG (Right)	
110C	1001255105	1	Decal - JLG (Left)	
110C	1001287763	1	Decal - JLG Gate	
110C	1001288431	2	Decal - JLG Platform	
110C	1001288435	1	Decal - JLG Billboard	
152		Ref	Decal - No Pipe Racks Allowed Options:	
152	1001092071	1	Decal - No Pipe Racks Allowed (English) (ANSI, ANSI Export and China Specs)	
152	1001092497	1	Decal - No Pipe Racks Allowed (English) (CE, Japanese & UK CA Specs)	
152	1001120623	1	Decal - No Pipe Racks Allowed (Spanish/Portuguese) (Brazil Specs)	

SECTION 8 - DECALS

ITEM	PART NUMBER	QTY	DESCRIPTION	REV
152	1001120622	1	Decal - No Pipe Racks Allowed (English/Chinese) (China Specs)	
152	1001092580	1	Decal - No Pipe Racks Allowed (English/French) (CSA Specs)	
152	1001120621	1	Decal - No Pipe Racks Allowed (English/Korean) (Korean Specs)	
152	1001120629	1	Decal - No Pipe Racks Allowed (English/Spanish) (Latin American Specs)	
156	1001173703	1	Decal - EAC (Russian/CIS Specs)	
245	1001236984	Ref	Decal - ClearSky	
245A	1001166208	1	Decal - ClearSky	
245B	1001120989	1	Decal - Radio Frequency	

SECTION 9 - RECOMMENDED SERVICE PARTS STOCK

SECTION 9 - RECOMMENDED SERVICE PARTS STOCK

SECTION 9 - RECOMMENDED SERVICE PARTS STOCK

FIGURE 9-1. RECOMMENDED SERVICE PARTS STOCK

ITEM	PART NUMBER	QTY	DESCRIPTION	REV
		Ref	Note: The following list will service one machine (built to current production per date on the front cover) with emergency repair parts which can be installed in the field. Parts from the list should be replaced when inventory is depleted to keep service parts stock supplied. For further information, contact your JLG dealer or the JLG Industries Parts Department.	
	1001189172	1	Breaker 16Amp Double (CE & UK CA Specs Machines)	
	1001189171	1	Breaker 30mAmp (CE & UK CA Specs Machines)	
	1001181045	1	Breaker 30mAmp/16Amp (CE & UK CA Specs Machines)	
	70005893	1	Coil (Valve Assembly)	
	1600402	1	Controller, Drive/Steer	
	3990001	2	Diode, 3A (Charger Harness)	
	1001196634	2	Fuse, 2A (Charger Harness)	
	8229242	2	Fuse, 5A (Chassis Harness)	
	2400061	2	Fuse, 10A (Worklight Cable)	
	8229244	2	Fuse, 15A (Chassis Harness)	
	2860030	1	Key, Replacement	
	1001134821	1	Latch, Magnalatch Side Pull (Gate Latch Installation)	
	3080007	1	Latch, Magnet (Fixed Rails with Gate)	
	2940129	1	Latch, Under Center Draw (Fold Down Rails with Gate)	
	1001200629	1	Module, Control (Electrical Components Installation)	
	1001228112	1	Module, Platform (Platform Control Box)	
	1001274605	1	Module, Platform (Platform Control Box) (Indoor Only)	
	1001216062	1	Module, Power (Electrical Components Installation)	
	3740150	1	Relay (Electrical Components Installation, Inverter Installation & Ground Control Installation)	
	1001146963	1	Sensor, Angle (Scissor Arms Installation)	
	1001203871	1	Sensor, Limit (Pothole Protection)	
	1001102771	1	Sensor, Temperature (Charger Harness)	
	1001186466	1	Sensor, Tilt	
	4360475	1	Switch, Emergency Stop	
	4360469	1	Switch, Key	
	1001226749	1	Switch, Push Button (Platform Control Box)	
	1001226277	1	Switch, Overhead Protection	
	4360328	1	Switch, Toggle (Electrical Components Installation)	
	4360336	1	Switch, Toggle (Machines with Inverter)	
	1001258446	1	Switch, Toggle (Platform Control Box)	
	1001276738	1	Switch, Toggle (Ground Control Installation)	

SECTION 10 - SPECIAL OPTIONS/ACCESSORIES/KITS

SECTION 10 - SPECIAL OPTIONS/ACCESSORIES/KITS

SECTION 10 - SPECIAL OPTIONS/ACCESSORIES/KITS

FIGURE 10-1. SPECIAL OPTIONS/ACCESSORIES/KITS

ITEM	PART NUMBER	QTY	DESCRIPTION	REV
		Ref	Note: This list is to accommodate machines ordered with special equipment. Options may not be applicable to all models. For more specific parts information contact the JLG Parts Department.	
		Ref	MISCELLANEOUS SPECIAL OPTIONS/ACCESSORIES/KITS	
	1001236903	Ref	Antivandalism Package (Factory Installed)	
	1001249639	Ref	Antivandalism Add-on Kit (Dealer Installed)	
	1001255597	Ref	Battery Charger Add-on Kit (Can)	
	1001249326	Ref	Beacon Light Add-on Kit (Dual Lights)	
	1001249229	Ref	Beacon Light Add-on Kit (Single Light)	
		Ref	ClearSky Add-on Kit Options (Dealer Installed):	
	1001278848	Ref	ClearSky Add-on Kit - 3-Wire (All Specs)	
	1001265376	Ref	ClearSky Add-on Kit - Canbus (ANSI, ANSI Export & CSA Specs)	
	1001237257	Ref	ClearSky Add-on Kit - Canbus (ANSI Export, CE & UK CA Specs)	
	1001248502	Ref	ClearSky Add-on Kit (Australian Specs)	
	1001248503	Ref	ClearSky Add-on Kit (China Specs)	
	1001248689	Ref	ClearSky Add-on Kit - Access Control	
	1001293819	Ref	ClearSky Telematics CS550 Installation	
	1001293899	Ref	ClearSky Telematics without Beacon Installation	
	1001293956	Ref	ClearSky Telematics (Second Beacon) Installation	
	1001239115	Ref	Ground Control Box Cover Kit	
		Ref	Decal Kit Options:	
	1001274823	Ref	R1932 Decal Kit	
	1001274824	Ref	R1932i Decal Kit	
	1001276702	Ref	Drive Motor Covers installation	
	1001229076	Ref	Drive Noise Reduction Add-on Kit	
		Ref	Electrical Connector Kits	
	1001148902	Ref	Amp/Tyco Electrical Connector Kit	
	1001148903	Ref	Deutsch DT Electrical Connector Kit	
	1001148904	Ref	Deutsch HD Electrical Connector Kit	
	1001148905	Ref	Packard Electrical Connector Kit	
	1001148906	Ref	Various Electrical Connector Kit	
	1001255009	Ref	European Subassembly Installation - R1932 (With Conccentric Pump/Motor)	D
	1001284887	Ref	European Subassembly Installation - R1932 (With Bucher Pump/Motor)	A
	1001217667	Ref	Fire Extinguisher Installation	
	1001241486	Ref	Foot Latch Add-on Kit	
	1001208061	Ref	Footswitch Installation (ANSI Export, Japanese and Korea Specs Only)	
	1001225925	Ref	Inverter Add-on Kit (ANSI USA Specs Only)	
	1001220933	Ref	Height Restrictor Switch Installation	
	1001269704	Ref	Hostile Environment Installation (Steer)	
	1001245353	Ref	Mobile Control Installation (Factory Installed)	
	1001250532	Ref	Mobile Control Add-on Kit (Dealer Installed)	
	1001258356	Ref	Operator Access Control	
	1001229727	Ref	Overhead Protection Add-on Kit (ANSI Export Specs Only)	
	1001258633	Ref	Panel Decals Installation	
	1001270721	Ref	Pipe Racks Kit (Dealer Installed) (R1932)	

SECTION 10 - SPECIAL OPTIONS/ACCESSORIES/KITS

ITEM	PART NUMBER	QTY	DESCRIPTION	REV
	1001269651	Ref	Platform Console Box Cover Add-on Kit (Dealer Installed)	
	1001225790	Ref	Platform Extension Deployment Handles Add-on Kit	
	1001265316	Ref	Pothole Protection Add-on Kit (Dealer Installed)	
	1001269798	Ref	Rail (Quick Access Rail) Add-on Kit (Dealer Installed) (R1932 & R1932i)	
	1001255000	Ref	Remote Tow Valve Installation	
	1001224583	Ref	Service Kits List	Y
	1001255883	Ref	Skysense Level 1 Installation (Factory Installed) (R1932/R1932I)	
	1001254721	Ref	Skysense Level 1 Add-on Kit (Dealer Installed) (R1932/R1932I)	
	1001265315	Ref	Steer Cover Add-on Kit (Dealer Installed) (R1932) (China Specs)	
	1001262557	Ref	Swing Gate Kit	
		Ref	Tools for Service	
	2901443	Ref	Analyzer Kit	
	1001232474	Ref	Benchtop Harness	
	8896941	Ref	Wire Stripper	
	7002821	Ref	Wire Crimper (To install wire ends to wires)	
	7002823	Ref	Pin/Socket Extractor - Universal (To Remove Pins/Sockets from Connectors)	
	4460467	Ref	Extractor - 16-18 Gauge (For Removal Pins/Sockets from Deutsch Connectors)	
	4460510	Ref	Extractor - 12-14 Gauge (For Removal of Pins/Sockets from Deutsch Connectors)	
	1001301945	Ref	Rail (Spare Service) Kit	
	7002822	Ref	Screwdriver, Potentiometer (To Adjust Drive Controllers)	
	7016654	Ref	Screwdriver, Magnetic	
	7004275	Ref	Seal Installation Tool - 1in	
	7004276	Ref	Seal Installation Tool - 1-1/2in	
	7002826	Ref	Seal Installation Tool - 2in	
	1001264614	Ref	Tool Tray Accessory (Dealer Installed)	
	1001269646	Ref	Tool Tray Add-on Kit (Dealer Installed)	
	1001281951	Ref	USB & Phone Cradle Kit - R1532i	
	1001262959	Ref	Voltage Regulator Re-Location Kit	
	1001281944	Ref	White Noise Alarm Kit	
	1001281414	Ref	Worklights Kit - R1932	

SECTION 10 - SPECIAL OPTIONS/ACCESSORIES/KITS

PART NUMBER INDEX

SECTION 10 - SPECIAL OPTIONS/ACCESSORIES/KITS

0100011.....15, 17, 19, 25, 33, 35, 37, 57, 59, 61, 63, 79, 81, 157, 167, 169, 173, 175	112, 116, 121, 126, 130, 134, 139	1001131270 357, 367	1001198935..... 112, 126, 139, 217
0100051...95, 97, 99, 101	0760613..... 79, 81	1001132358 185, 187, 189	1001200441.....29
0140030.....185, 187, 189	0760618 177	1001132359 357, 359, 361, 363, 365, 367, 369, 371	1001200561....39, 43, 47, 57
0140043.....87, 91	0760810.79, 81, 157, 211	1001132361 185, 187, 189	1001200629....87, 89, 91, 376
0275216.....239, 343	0760812..... 157, 169	1001134280 263	1001200631.....87, 89
0275217.....241, 345	0760820 211	1001134289 113, 117, 122, 127, 131, 135, 140	1001200632.....93
0275452.....243, 347	0760827 231, 233	1001134821 183, 376	1001200811.....307, 311, 315, 317
0275453.....245, 349	0761012... 15, 17, 19, 79, 81	1001136757 103	1001200812.....299, 307, 309, 319
0275454.....247, 351	0761019 163, 177	1001137675 157, 173	1001200819..... 185, 333
0440223.....203, 209	0761217 105, 107	1001142173 103	1001201087.....307
0440259.15, 17, 223, 225	0861731 ... 341, 347, 349, 351	1001142174 103	1001201129.....315
0440263.....33	0861781 343, 345	1001143009 103	1001201248.....15, 17
0440264.....140, 143, 145	0861880 253	1001143010 103	1001201355.....126, 130, 139, 145
0440265.....140, 143, 145	0962292 217, 219	1001143501 231, 233	1001201707.....67
0480100.....201	1001047064 185, 187, 189	1001144147 293, 297	1001201708....95, 97, 99, 101
0630183.....157	1001091102... 33, 35, 65, 67, 87, 91, 169	1001144295 276	1001201711....95, 97, 99, 101
0630587...87, 89, 91, 103	1001092071 373	1001144296 276	1001201885.....333, 335, 337
0630613.....71, 147	1001092497 373	1001146794 357, 359, 361, 363, 365, 367, 369, 371	1001202184.....301, 311, 313, 321
0641416.....177	1001092580 374	1001146963 112, 116, 121, 126, 130, 139, 376	1001202300.....15
0700412.....87, 91	1001097347 291, 293	1001148902 378	1001202731.....29
0700610....167, 169, 203, 209	1001100341 343	1001148903 378	1001202773.....25
0700612....33, 35, 37, 63, 73, 75	1001100342 345	1001148906 378	1001202851.....79
0700614....21, 23, 39, 41, 43, 45, 47, 49, 51, 53, 55	1001100345 347	1001151629 275	1001202987.....33, 35
0700616.....197	1001100346 351	1001152266 276	1001202988.....33, 35
0700617.....87, 89, 91	1001100347 349	1001152483 255	1001202994.....33, 35
0700620....112, 116, 121, 126, 130, 134, 139	1001101540 103	1001153785 15, 17, 19	1001202999.....33, 35
0700621181	1001102258 237, 239, 241, 243, 245, 247, 249, 251	1001154378 163, 173	1001203443.....112, 116, 121, 126, 130, 139, 151, 153
0700626.....169	1001102489... 39, 41, 43, 45, 47, 49, 51, 53, 55, 259, 261, 265, 267, 269, 271, 273	1001157547 103	1001203444.....112, 116, 121, 126, 130, 139
0700812.....167	1001102771 257, 376	1001159186 275, 333, 335, 337	1001203445.....112, 116, 121, 126, 130, 139
0700814.....263	1001103012 276, 295	1001162115 369	1001203446.....112, 116, 121, 126, 130, 139
0700815.....33, 35	1001103013 295	1001162864 357, 359, 361, 363, 365, 367, 369, 371	1001203450.....79, 81
0700817105, 107, 201	1001103471 263	1001162886 275	1001203453.....71
0700818....159, 163, 167, 169, 173, 175, 177, 181	1001104498 295	1001162887 275, 295	1001203457.....112, 116, 121, 126, 130, 139
0700819....151, 153, 155, 183	1001112112 97	1001163340 275, 295	1001203448.....112, 116, 121, 126, 130, 139
0700820.....173	1001113961 276	1001166208 374	1001203450.....79, 81
0700823.....33, 35	1001116731 293, 295	1001173703 374	1001203453.....71
0700835.....185, 187, 189	1001116732 291, 293	1001181045 253, 376	1001203457.....71
0701014.....73	1001116812 257, 275	1001182806 69	1001203630.....311
0701015....105, 107, 112, 116, 121, 126, 130, 134, 139	1001117000 275	1001186466 37, 376	1001203631.....317
0701018.....173	1001117057 291, 293	1001187587 163, 167, 169, 173, 177	1001203835.....231
0701019....147, 173, 197	1001118812 297	1001187781 87, 91	1001203837.....231, 233
0701021....112, 116, 121, 126, 130, 134, 139, 151, 153, 155	1001120204 239, 241, 243, 245, 247	1001188116 249	1001203838.....231, 233
0701024.....147	1001120205 253, 255	1001189171 255, 376	1001203839.....231, 233
0760310.....323, 325	1001120621 374	1001189172 255, 376	1001203840.....231, 233
0760408....237, 239, 241, 243, 245, 247, 249	1001120622 374	1001189762 203, 209	1001203844.....231, 233
0760608..87, 89, 91, 163, 177, 199, 213	1001120623 373	1001192401 276	1001203846.....231, 233
0760610....53, 87, 89, 91, 103, 183, 185, 187, 189, 199	1001120629 374	1001194421 333, 335, 337	1001203869.....33
0760612....39, 41, 43, 45, 47, 49, 57, 59, 61, 69,	1001120989 374	1001196634 257, 289, 376	1001203870.....33
	1001125483 103	1001197396 15, 17, 19	1001203871.33, 169, 376
	1001125677 276, 297	1001197457 276	1001203872.....33, 35
	1001130220... 39, 41, 43, 45, 47, 49, 51, 53, 55, 57, 59, 61, 63, 73, 75, 87, 89, 91, 185, 187, 189		1001203973.....135, 140, 145
	1001130590 87, 89, 91		

SECTION 10 - SPECIAL OPTIONS/ACCESSORIES/KITS

1001203974 135, 140, 143, 145	1001209776..... 239, 241, 247, 253	1001214810..... 105, 107	1001224620 147
1001203975 135, 140, 143, 145	1001209906..... 373	1001215747 365	1001224622 147
1001203976 135, 140, 143, 145	1001209907..... 357	1001215748..... 361, 371	1001224623 147
1001204087 126	1001209908..... 369	1001215749..... 363, 367	1001225164 112, 116, 121, 126, 130, 134, 139
1001204174 79, 83	1001209909..... 365	1001215750..... 369	1001225377 299, 301, 303, 305
1001204311 112, 116, 121, 126, 130, 134, 139	1001209910..... 361	1001215751..... 369	1001225490 299
1001204312 112, 116, 121, 126, 130, 134, 139	1001209911..... 371	1001215752..... 365	1001225491 301
1001204495 69	1001209913..... 363	1001215753..... 363, 367	1001225492 303
1001204621 135, 140, 143, 145	1001209914..... 359	1001215762..... 87, 89	1001225493 305
1001204719 79	1001209920..... 103	1001215953..... 33, 35	1001225790 379
1001204781 151	1001210064..... 157	1001216062..... 87, 89, 91, 376	1001225925 378
1001204994 112, 116, 121, 126, 130, 139	1001210302..... 159, 163, 167, 169, 173, 175	1001216180..... 95	1001226277 197, 376
1001205156 151, 153, 155	1001210401..... 95, 97, 99, 101	1001216250..... 99	1001226636 293, 295
1001205409 275	1001210440..... 103	1001216648..... 361	1001226637 293, 295
1001205410 275	1001210442..... 163, 165	1001216650..... 361	1001226749 185, 187, 189, 376
1001205411 275	1001210443..... 163, 165	1001216823..... 181	1001226791 112, 116, 121, 126, 130, 134, 139
1001205412 275	1001210444..... 163, 165	1001217043..... 157	1001227219 263
1001205422 157	1001210445..... 163, 165	1001217059..... 37	1001227267 263
1001205423 157	1001210446..... 163, 165, 177	1001217164..... 253, 255	1001227703 373
1001205424 157	1001210447..... 163, 165	1001217667..... 213, 378	1001227966 73, 75
1001205430 157	1001210458..... 163, 165	1001218285..... 185, 187, 189	1001228112 187, 189, 376
1001205598 51, 55, 63	1001210586..... 159, 163, 167, 169, 173, 175	1001218307..... 33, 35	1001228123 ... 95, 97, 99, 101
1001205709 153	1001210605..... 103	1001218509..... 213	1001228184 197
1001205751 15	1001210878..... 103	1001218573..... 105	1001228370 357, 363, 367
1001206207 159, 161	1001210879..... 103	1001219171..... 359	1001228406 105, 107
1001206217 159, 161	1001210880..... 103	1001219172..... 359	1001228954 283
1001206222 159, 161	1001210881..... 103	1001219265..... 367	1001229076 378
1001206224 159, 175	1001210882..... 103	1001220216..... 197	1001229110 ... 95, 97, 99, 101
1001206225 159, 163	1001210963..... 159, 163, 167, 169, 173, 175, 177	1001220409..... 183	1001229722 173
1001206226 159, 163, 167, 169, 177	1001210966..... 87, 89, 91	1001220410..... 183	1001229727 378
1001206228 159, 161	1001210967..... 103	1001220430..... 357, 359, 361, 363, 365, 367, 369, 371	1001229792 105
1001206487 112, 116, 121, 126, 130, 134, 139	1001210967..... 103	1001220570..... 15, 223	1001230839 309, 313
1001206995 53, 61	1001211777..... 357	1001220893..... 185, 187, 189	1001230932 309
1001207009 ... 39, 41, 43, 45, 47, 49, 57, 59	1001211779..... 357, 363, 365, 367, 369, 371	10012221244..... 197	1001230933 313
1001207293 93	1001211895..... 173	10012221275..... 197	1001231268 112, 116, 121, 126, 130, 134, 139
1001207494 87, 89, 91	1001212035..... 333, 335, 337	10012221276..... 197	1001231801 357
1001207806 159	1001212036..... 333, 335, 337	10012221475..... 157	1001232257 173
1001207807 163	1001212068..... 33, 35	10012221476..... 157	1001232474 379
1001207970 ... 43, 45, 53, 261	1001212290..... 357, 359, 361, 363, 365, 367, 369, 371	10012221949..... 47, 49	1001232586 211
1001207973 51, 273	1001212291..... 357, 359, 361, 363, 365, 367, 369, 371	1001222587..... 181	1001234204 112, 116, 121, 126, 130, 134, 139
1001207974 ... 39, 41, 55, 259, 263, 265, 267, 269, 271	1001212292..... 357, 359, 361, 363, 365, 367, 369, 371	1001222687..... 112, 116, 121, 126, 130, 139, 329	1001234395 177
1001208057 95	1001212293..... 357, 359, 361, 363, 365, 367, 369, 371	1001222914..... 197	1001235018 151
1001208058 97	1001212294..... 79	1001223055..... 357	1001235024 143
1001208061 378	1001213448..... 276	1001223262..... 305, 317	1001235025 143
1001208073 163, 165	1001213554..... 135, 140, 143, 145	1001223263..... 303, 315	1001235059 112, 116, 121, 143
1001208852 157	1001213886..... 185, 187, 189	1001223650..... 319	1001235060 112
1001208930 237	1001214217..... 37	1001223651..... 321	1001235104 112, 116, 126, 130, 134
1001208931 251	1001214347..... 99	1001223835..... 175	1001235105 ... 39, 41, 43, 45, 47, 49
1001208938 249	1001214526..... 33, 35	1001223971..... 363, 367	1001235152 43
1001209482 243, 245, 255		1001224048..... 369	1001235153 39
1001209596 185		1001224049..... 371	1001235154 51
1001209682 87, 89, 91		1001224051..... 365	1001235156 55
		1001224052..... 361	1001235157 53
		1001224468..... 197	1001235158 47
		1001224583..... 379	
		1001224604..... 147	
		1001224608..... 147	
		1001224614..... 147	

SECTION 10 - SPECIAL OPTIONS/ACCESSORIES/KITS

1001235536.....199	1001251232..... 105, 107	1001256503 263	1001265376.....378
1001235541.....151, 153, 155	1001251233..... 105, 107	1001256642 57, 59	1001269480.....81
1001235559.....87, 89, 91	1001251234..... 105, 107	1001256643 61, 63	1001269507..... 17, 19
1001235863.....199	1001251235..... 105, 107	1001256657 167, 169	1001269646.....379
1001235924.....199	1001251242..... 105	1001256675 177, 373	1001269651.....379
1001235941.....201	1001251383..... 177	1001256676 373	1001269704..... 21, 378
1001235946.....51, 53, 55	1001251388..... 177	1001256787 117, 122, 131, 219	1001269730..... 79, 81
1001236129.....157	1001251437..... 33, 35	1001256788 17, 225	1001269798.....379
1001236139.....39, 41, 43, 45, 47, 49, 51, 53, 55, 57, 59, 61, 63	1001252626..... 203, 209	1001257171 373	1001269943.....335, 337
1001236144.....283, 285, 287	1001253038..... 79, 81	1001257172 373	1001269944.....323, 339
1001236507.....199	1001253039..... 73	1001257173 373	1001269946.....335, 337
1001236903.....378	1001253153..... 113, 116, 121, 127, 130, 134, 139	1001257773 357, 359, 361, 363, 365, 367, 369, 371	1001269947.....323, 339
1001236984.....374	1001253280..... 239, 241, 243, 245, 247	1001257890 177	1001269949.....323, 339
1001237211.....295	1001253358..... 79, 231	1001258356 378	1001269999..... 189, 335
1001237212.....276, 295	1001253359..... 73	1001258411 178	1001270443.....323
1001237213.....295	1001253653..... 45	1001258446 185, 187, 189, 376	1001270470..... 187, 189
1001237257.....378	1001253654..... 41	1001258498 101	1001270471..... 187, 189
1001238762.....295	1001253655..... 49	1001258528 177	1001270533.....201
1001238845.....287, 295	1001253800..... 195	1001258617 177	1001270631.....201
1001238955.....295	1001253871..... 89	1001258618 177	1001270721.....378
1001238956.....295	1001253952... 41, 45, 49, 59	1001258620 177	1001270823.....23
1001239115.....378	1001254026..... 281, 283, 285, 293	1001258633 378	1001270855.....201
1001239224.....65, 67	1001254027... 41, 45, 49, 59, 281, 283, 285, 297	1001258704 177	1001270899.....323
1001239544.....323, 325	1001254028... 41, 45, 49, 59, 257	1001258768 267	1001271412.....201
1001239661.....65, 67	1001254173..... 79, 81	1001258770 265	1001271574.....23
1001241486.....378	1001254174..... 79, 81	1001258771 269	1001271892.....173
1001241604.....135, 140, 145	1001254225..... 231, 233	1001258772 271	1001271897.....173
1001241605.....135, 140, 145	1001254226..... 231, 233	1001258822 373	1001271902.....173
1001242539.....65, 67	1001254227..... 231, 233	1001258899 373	1001271908.....173
1001242697.....65	1001254444..... 87	1001258900 373	1001271912.....173
1001243528.....177	1001254636..... 243	1001259102 167, 169	1001271913.....173
1001244298.....365	1001254637..... 245	1001259105 167, 170	1001271919.....173
1001245353.....378	1001254638..... 247	1001259106 167, 170	1001271921.....173
1001246144.....285	1001254639..... 239	1001259107 167, 170	1001271925.....173
1001246145.....287	1001254640..... 241	1001261040 177	1001271929.....173
1001246531.....287	1001254721..... 379	1001261131 195	1001271933.....173
1001247862.....67	1001254825..... 177	1001262150 195	1001271935.....173
1001247926.....101	1001255000..... 379	1001262221 191	1001271937.....173
1001248502.....378	1001255009..... 378	1001262299 23, 117, 122, 131	1001272023.....173
1001248503.....378	1001255102..... 373	1001262322 281	1001272659.....279
1001248631.....259	1001255104..... 373	1001262327 281	1001272997.....289
1001248632.....261	1001255105..... 373	1001262464 21, 23	1001273012.....279, 289
1001248633.....263	1001255417..... 167	1001262557 379	1001273907.....203, 209
1001248689.....378	1001255420..... 167, 170	1001262655 185	1001273957.....205, 207
1001249082.....177	1001255421..... 167, 170	1001262959 379	1001273958.....207
1001249096.....177	1001255428..... 167, 170	1001263256 57	1001273960.....209
1001249107.....177	1001255430..... 167, 170	1001263257 59	1001273961.....211
1001249109.....177	1001255442..... 167, 170	1001263258 61	1001273962.....211
1001249110.....178	1001255447..... 167, 170	1001263259 63	1001273964.....211
1001249111.....177	1001255457..... 167, 170	1001263294 273	1001273965.....211
1001249112.....178	1001255470..... 167, 169	1001263509 130	1001273966.....211
1001249114.....177	1001255491..... 167, 170	1001263536 116, 121	1001274026.....211, 331
1001249229.....378	1001255506..... 231	1001263538 17	1001274168..... 195
1001249326.....378	1001255555..... 105	1001263805 169	1001274559...87, 89, 91, 187, 189
1001249639.....378	1001255597..... 378	1001263808 169	1001274604..... 185
1001250378.....33	1001255883..... 379	1001263850 169	1001274605..... 185, 189, 376
1001250431.....75	1001255901..... 289	1001264079 169	1001274613.....187
1001250532.....378	1001256174..... 373	1001264110 169	1001274659..... 185
1001251144.....281	1001256175..... 373	1001264614 379	1001274660.....187
1001251145.....283	1001256176..... 373	1001265048 373	1001274661.....191
1001251146.....285	1001256471..... 177	1001265315 379	1001274823.....378
		1001265316 379	1001274824.....378
			1001274837.....205, 207
			1001274838.....203, 209

SECTION 10 - SPECIAL OPTIONS/ACCESSORIES/KITS

1001275631 205, 207	1001286514..... 175	1704412.... 357, 359, 361,	112, 116, 121, 126,
1001276584 19	1001286517..... 175	363, 365, 367, 369, 371	130, 134, 139, 157,
1001276585 134	1001286522..... 175	1704684..... 363, 367	167, 169, 177, 213,
1001276586 31	1001286627..... 175	1704691..... 371	239, 241, 243, 245,
1001276592 81, 233	1001286736..... 167, 169	1704699..... 361	247, 281, 283, 285
1001276600 91	1001286868..... 139	1705195..... 365	3290606 ... 159, 163, 167,
1001276659 91	1001287711..... 201	1705647..... 373	169, 173, 175, 177,
1001276696 19	1001287763..... 373	1705648..... 373	181, 183, 197, 199,
1001276699 19	1001288431..... 373	1705670..... 359	203, 209
1001276701 19, 227	1001288434..... 373	1705997..... 205, 207	3290801 33, 35, 211
1001276702 378	1001288435..... 373	1707022..... 369	3290805. 33, 35, 81, 105,
1001276704 107	1001288509..... 373	2030011..... 213	107, 151, 153, 155,
1001276705 155	1001288510..... 373	2080040.... 157, 159, 163,	157, 201, 231, 233, 263
1001276707 134, 155	1001289248..... 25, 27	167, 169, 173, 175,	3290806... 159, 163, 167,
1001276708 31	1001290404..... 25	177, 357, 359, 361,	169, 173, 175, 177,
1001276711 81	1001291630..... 187	363, 365, 367, 369, 371	181, 183, 185, 187, 189
1001276712 81, 85	1001293819..... 378	2080043..... 177	3291005 73, 105, 107,
1001276713 81	1001293899..... 378	2080057 357, 359, 361,	147, 157
1001276715 107	1001293956..... 378	363, 365, 367, 369, 371	3291006 71, 147, 163,
1001276716 107	1001294256..... 134	2220371..... 83	173, 177, 197
1001276717 107	1001295195..... 134	2220372..... 83	3291007 ... 105, 107, 112,
1001276718 35	1001301945..... 379	2220373..... 231, 233	116, 121, 126, 130,
1001276720 35	1060379 ... 201, 203, 205,	2220374..... 83	134, 139, 151, 153, 155
1001276721 35	207, 209	2220375..... 231, 233	3291201 105, 107
1001276722 35	1060908 253, 255	2220415..... 83, 231, 233	3311502 157
1001276725 134	1060998 .. 95, 97, 99, 101	2220497 231, 233	3321402... 112, 116, 121,
1001276726 135	1061034 ... 112, 116, 121,	2220502..... 231, 233	126, 130, 134, 139
1001276727 135	126, 130, 134, 139	2220582..... 83	3331211 25
1001276728 134	1061041 211, 353	2220828..... 231, 233	3340962... 112, 116, 121,
1001276729 134	1062255 ... 281, 283, 285,	2220883..... 219	126, 130, 134, 139,
1001276730 134	287	2221086..... 83	167, 169
1001276731 134	1120555 205, 207	2221116.... 112, 116, 121,	3421453 203, 209
1001276732 134	1320136 ... 281, 283, 285	126, 130, 134, 139	3422219... 163, 177, 203,
1001276733 135	1321293 ... 39, 41, 43, 45,	2400060..... 257, 276	205, 207, 209
1001276734 135, 221	47, 49, 51, 53, 55, 57,	2400061..... 353, 376	3422661 201
1001276738 91, 376	59, 61, 63, 103	2400066..... 353	3423037 15, 17, 19
1001276740 91	1321752 231, 233	2420172..... 87, 89	3423243 105, 107
1001276741 35	1380132 181	2560088.... 167, 170, 181	3423278 185, 187, 189
1001276743 35	1380153 15, 17, 19	2560190..... 181	3430636 33, 35
1001276979 91	1580023 205, 207	2600281.... 159, 163, 167,	3430814 157
1001278513 279, 291	1580024 205, 207	169, 173, 175, 177	3430816 157
1001278847 279	1600402 ... 185, 187, 189,	2700100..... 205, 207	3431212 33, 35
1001278848 378	193, 376	280013..... 127, 139	3431218 33, 35
1001278882 233	1671207 341	2860030..... 87, 89, 376	3450302 33, 35
1001278904 233	1701504 ... 357, 359, 361,	2901443..... 379	3450303 105, 107
1001279476 169	363, 365, 367, 369, 371	2902431..... 237, 341	3450403 157
1001279477 169	1701640 ... 357, 359, 361,	2940129..... 376	3450505 33, 35
1001281414 379	363, 365, 367, 369, 371	3080007.... 159, 163, 167,	3450508 29, 31
1001281944 379	1702010 199	169, 173, 175, 376	3460334 205, 207
1001281951 379	1702155 .. 95, 97, 99, 101	3252507.... 241, 243, 245,	3520072 ... 147, 159, 163,
1001282611 167, 170	1703464 237, 239	247, 249, 251	167, 169, 173, 175,
1001282612 167, 170	1703813 357	3290305. 65, 67, 323, 325	177, 203, 209
1001282613 167, 169	1703816 357	3290405.... 33, 35, 87, 91,	3574505 199
1001283408 .. 87, 91, 275	1703819 ... 185, 187, 189,	103, 112, 116, 121,	3740150. 87, 91, 103, 376
1001284887 378	357, 359, 361, 363,	126, 130, 134, 139,	3760115... 112, 116, 121,
1001285320 121, 134,	365, 367, 369, 371	167, 169, 183, 185,	126, 130, 134, 139
139	1703822 ... 357, 359, 361,	187, 189, 237, 239,	3760170... 112, 116, 121,
1001285829 122, 139,	363, 365, 367, 369, 371	241, 243, 245, 247, 249	126, 130, 134, 139,
327	1704016 ... 357, 359, 361,	3290406..... 169	203, 205, 207, 209
1001286159 189	363, 365, 367, 369, 371	3290501..... 177	3760217 15, 17, 19
1001286161 337	1704260 185, 187, 189	3290505..... 263	3760387 ... 112, 116, 121,
1001286164 325	1704277 ... 357, 359, 361,	3290506..... 167, 169	126, 130, 134, 139
1001286165 189	363, 365, 367, 369, 371	3290601..... 37	3820019 181
1001286166 325, 339	1704339 371	3290605.... 21, 23, 39, 41,	3820032 177
1001286509 175	1704340 363, 367	43, 45, 47, 49, 51, 53,	3841143... 105, 107, 112,
1001286510 175	1704341 361	55, 57, 59, 61, 63, 69,	116, 121, 126, 130,
1001286512 175	1704344 365	79, 81, 87, 89, 91, 103,	134, 139

SECTION 10 - SPECIAL OPTIONS/ACCESSORIES/KITS

3841675.....203, 209	4360469...87, 89, 91, 376	4460754 ... 299, 301, 303,	4740531.... 112, 116, 121,
3860111.... 159, 163, 167,	4360475 87, 89, 185, 189,	305, 307, 309, 311,	126, 130, 134, 139
169, 177	376	313, 315, 317, 319, 321	4811400.... 103, 112, 116,
3900355.....205, 207	4420037 199	4460761 275	121, 126, 130, 134,
3900381.....263	4420051 373	4460844 169	139, 167, 169, 183,
3910804.....87, 89, 91	4420062... 159, 163, 167,	4460871 257, 276	185, 187, 189, 237,
3931412.....205, 207	169, 173, 175, 177,	4460872 257	239, 241, 243, 245,
3931508.....205, 207	185, 187, 189, 201	4460877 275	247, 249
3990001.....257, 376	4460018 353	4460884 ... 257, 275, 291,	4811700.... 21, 23, 69, 79,
4010310.....65, 67	4460019 276	329	81, 87, 89, 91, 103,
4010408.....183	4460042 275	4460891 65, 67, 197, 257,	112, 116, 121, 126,
4010417.....169	4460115 275	275, 276, 303, 305,	130, 134, 139, 159,
4010608.... 159, 163, 167,	4460138 237	315, 317, 329, 331,	163, 167, 169, 173,
169, 173, 175, 177	4460183... 275, 333, 335,	339, 353	175, 177, 183, 185,
4010610.... 239, 241, 243,	337	4460894 ... 275, 276, 299,	187, 189, 199, 213,
245, 247	4460226 276	301, 303, 305, 307,	239, 241, 243, 245,
4010616.... 159, 163, 167,	4460227 ... 39, 41, 43, 45,	309, 311, 313, 315,	247, 281, 283, 285
169	47, 49, 57, 59, 275	317, 323, 325	4811702.... 33, 35, 37, 39,
4010617.....163, 173	4460234 ... 197, 281, 283,	4460897 69, 103, 257,	41, 43, 45, 47, 49, 51,
4010618.... 159, 163, 167,	285, 287	276, 303, 305, 315,	53, 55, 57, 59, 61, 63,
169, 173, 175, 177, 213	4460247 275	317, 331, 339	73, 75, 112, 116, 121,
4031506.....167, 169	4460259 275	4460899 ... 112, 116, 121,	127, 130, 134, 139, 181
4031509.... 185, 187, 189	4460260 275	126, 130, 134, 299,	4811900.. 33, 35, 81, 151,
4031511.....33, 35, 169	4460265 333, 335, 337	301, 303, 305, 307,	153, 155, 157, 159,
4031512.... 112, 116, 121,	4460267 ... 333, 335, 337	309, 311, 313, 315,	163, 167, 169, 173,
126, 130, 134, 139	4460315 237, 249	317, 319, 321, 323,	175, 177, 181, 185,
4031707.....51, 55	4460320 276	325, 339	187, 189, 231, 233
4031708.... 37, 51, 55, 63,	4460346 341	4460905 257, 276	4811902.... 33, 35, 79, 81,
281, 283, 285	4460418... 103, 275, 333,	4460930 276	105, 107, 173, 175,
4060803 73, 75, 185, 187,	335, 337	4460932 ... 257, 289, 291,	183, 201, 211, 263
189	4460419 103	293, 295, 327	4812000.... 15, 17, 19, 33,
4060906.... 185, 187, 189	4460424 ... 39, 41, 43, 45,	4460933 275, 276, 297	35, 79, 81, 105, 107,
4071095.....177	47, 49, 57, 59	4460943 ... 293, 297, 299,	112, 116, 121, 126,
4160078.... 112, 116, 121,	4460464 69, 103, 112,	301, 303, 305, 307,	130, 134, 139, 147,
126, 130, 134, 139	116, 121, 126, 130,	309, 311, 313, 315,	157, 163, 173, 177, 197
4160202.....33	134, 170, 197, 257,	317, 319, 321, 323,	4812002 71, 73, 105, 107,
4160214.....105, 107	276, 289, 291, 293,	325, 339	157
4191706.....203, 209	295, 299, 301, 303,	4460944 ... 257, 275, 276,	4812500..... 33, 35
4220227.....203, 209	305, 307, 309, 311,	297, 299, 301, 303,	4831600..... 263
4220309.....177	313, 315, 317, 319,	305, 307, 309, 311,	4846757..... 15, 17, 19
4240003.... 203, 205, 207,	321, 323, 325, 327,	313, 315, 317, 323, 325	4923328... 95, 97, 99, 101
209	329, 331, 333, 339	4460956 253	5241000..... 157
4240017.... 39, 41, 43, 45,	4460465 65, 67, 169, 197,	4460957 253	5241200..... 25
47, 49, 51, 53, 55, 57,	257, 275, 276, 291,	4460965 275	5271808..... 79
59, 61, 63, 87, 89, 91,	299, 301, 303, 305,	4460968 249	5271811..... 81
95, 97, 99, 101, 103,	307, 309, 311, 313,	4460970 329	5272120..... 25
112, 116, 121, 126,	315, 317, 319, 321,	4460986 353	5272122..... 25
130, 134, 139, 169,	323, 325, 327, 329,	4461016 333	70000082..... 193
197, 231, 233, 237,	331, 339, 353	4461023 275	70000084..... 193
239, 241, 243, 245,	4460466 ... 170, 197, 257,	4461196 269, 343	70000683..... 193
247, 249, 251, 259,	275, 276, 293, 295,	4461198 343	70000684..... 193
261, 263, 265, 267,	297, 299, 301, 303,	4461199 271, 345	70000685..... 193
269, 271, 299, 301,	305, 307, 309, 311,	4461201 345	70000686..... 193
303, 305, 307, 309,	313, 315, 317, 319,	4461205 267, 347, 349	70001250..... 193
311, 313, 315, 317, 319,	321, 327, 329, 333, 339	4461244 347	70001251..... 193
321, 323, 325	4460467 379	4461245 349	70001252..... 193
4240018.....67	4460496 185	4461246 351	70001253..... 193
4240032.... 279, 281, 283,	4460497 185	4461249 265, 351	70001878.. 112, 116, 121,
285, 287	4460510 379	4461257 239, 241	126, 130, 134
4240033.....211	4460536 170, 197	4461258 239, 241	70002410..... 217
4240147.....33, 35	4460539 ... 276, 303, 305,	4711400 ... 203, 205, 207,	70003636..... 219, 225
4240165.....199	315, 317, 327, 329, 339	209	70003650..... 193
4340853.....205, 207	4460565 339	4711700 185, 187, 189	70004231..... 217
4340854.....205, 207	4460662 ... 243, 245, 247,	4711800 157	70004232..... 217
4340947.....203, 209	341	4740438 ... 112, 116, 121,	70004233..... 217
4360328.....87, 89, 376		126, 130, 134, 139	70004241..... 223
4360336.....103, 376		4740480 205, 207	70004585..... 219, 221

SECTION 10 - SPECIAL OPTIONS/ACCESSORIES/KITS

70005236 219, 221	70005898 83	70007573.....219	7004275 379
70005423 79	70005899 83	70007574.....219	7004276 379
70005790 217	70005900 83	70007575.....219	7016654 379
70005791 217	70005903 83	70007576.....219	7017470 85
70005792 217	70005904 83	70007577.....219	7020175 .87, 89, 185, 189
70005793 217	70005905 83	70007578.....219	7020176 .87, 89, 185, 189
70005794 217	70005907 83	70007579.....225	7020218... 112, 116, 121, 126, 130, 134
70005795 217	70005908 83	70007580.....225	7027365 193
70005796 217	70005909 83	70007581.....225	7027367 193
70005797 217	70005911 83	70007946.....79	7027765 193
70005798 223	70005912 83	70007991.....221	7027766 193
70005800 223	70005913 83	70008142.....219	80325 203, 209
70005803 223	70005914 83	70008143.....219	8036580 85
70005805 223	70005918 25	70008472.....227	8220045 276
70005815 79	70005919 25	70008576.....81	8229242 276, 376
70005816 79	70006143 223	70008577.....81	8229244 276, 376
70005817 79	70007077 225	70021209.....83	8750014 231, 233
70005891 83	70007079 225	70023370.....217	8896941 379
70005892 83	70007118 225	7002821.....379	8990147 ... 357, 359, 361, 363, 365, 367, 369, 371
70005893 83, 376	70007134 219	7002822.....379	
70005895 83	70007135 219	7002823.....379	
70005896 83	70007572 219	7002826.....379	



**Corporate Office
JLG Industries, Inc.
1 JLG Drive
McConnellsburg, PA 17233-9533 USA**
☎ **(717) 485-5161 (Corporate)**
☎ **(877) 554-5438 (Customer Support)**
📠 **(717) 485-6417**

**Visit our website for JLG Worldwide Locations.
www.jlg.com**



OSHKOSH™