



Illustrated Parts Manual

Models *10MSP*

PVC
2108

P/N
31219106
August 1, 2021 - Rev A

ANSI

CE



**UK
CA**

AS/NZS



An Oshkosh Corporation Company

REVISION LOG

August 1, 2021 - A - Original Issue of Manual (Edited to B/M 1001250313 F)

GENERAL INFORMATION

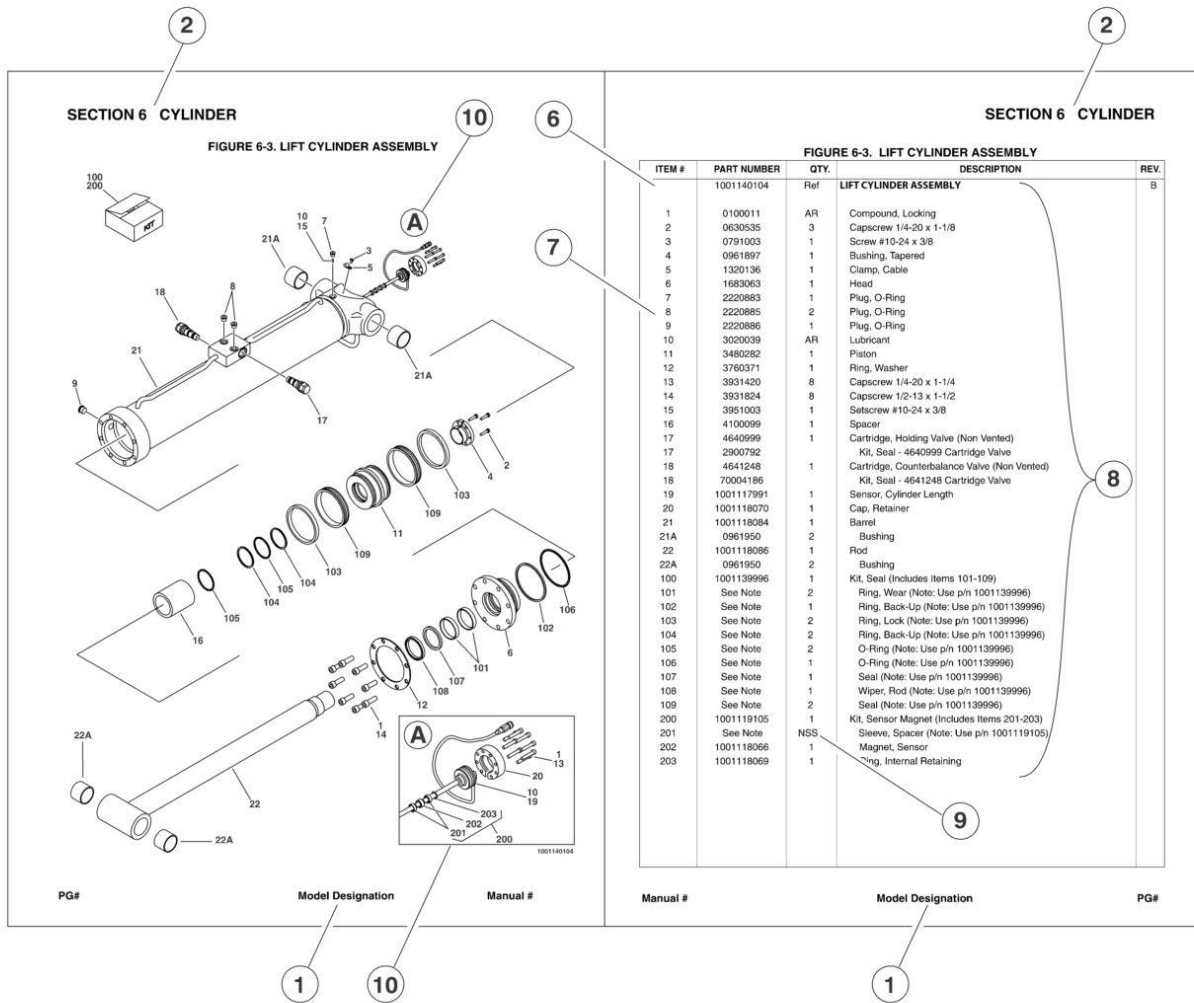

1) MACHINE IDENTIFICATION

Machines are identified by model and in some cases a combination of models, serial number (SN) or regional standard (i.e. ANSI, CE, CSA). Components may also be identified by SN or manufacturer. Common components that may be identified by these characteristics are engines and hydraulic components.

2) PARTS MANUAL ORGANIZATION

Product information in this manual is organized under section titles. Frame, Cylinder, Hydraulic and Electrical are a few examples. Each section is organized by figure and page number. The information within the figure is then organized by item number, part number, description and corresponding illustration(s).

3) TABLE OF CONTENTS

A table of contents is found toward the beginning of the manual. Figure number, description and page number are provided for quick reference to the page containing the related information.

4) RECOMMENDED SPARE PARTS

The Recommended Spare Parts, located near the end of the manual, reference most frequently used maintenance parts.

5) PART NUMBER INDEX

A numerical index listing all part numbers and the corresponding page number(s) appears at the back of the manual.

GENERAL INFORMATION

6) NON-SERVICED PARTS

In some instances, it is necessary to display non-serviced parts, assemblies or installations. In the case of assemblies and installations there will be a Ref in the Qty column. In case of parts that are not available for service within assemblies and components, there will be a NSS (Not Sold Separately) or NLA (No Longer Available) listed in the Qty. column of the manual.

7) PARTS LIST ITEM NUMBERS

Numbers shown in the item# column correspond to numbers used in the associated illustration (s). Item numbers which are missing from the sequence in the parts list are not used on that page

8) INDENTED PARTS DESCRIPTION

An indented part description is included in the item under which it is indented.

9) ABBREVIATION AND SYMBOLS

AC.....	.. Alternating Current	LCD.....	Liquid Crystal Display
ADE.....	Advanced Design Electronics	LED.....	Light Emitting Diodes
ANSI.....	American National Standards Institute	LH.....	Left Hand
AR.....	As Required	LSS.....	Load Sensing System
ASSY.....	Assembly	M(m).....	Metric/Meter
AUX.....	Auxiliary	MM (mm).....	Milimeter
AWG.....	American Wire Gauge	mA.....	Miliamps
B/M.....	Bill of Material	NLA.....	No Longer Available
CE.....	European Conformity	NPT.....	National Pipe Threads
CCW.....	Counter Clockwise	NSS.....	Not Sold Separately
cm.....	Centimeter	OD.....	Outside Diameter
CW.....	Clockwise	ORB.....	O-Ring Boss
CSA.....	Canadian Standard Association	ORFS.....	O-Ring Face Seal
CYL.....	Cylinder	OZ (oz).....	Ounces
DIA.....	Diameter	PG.....	Page
DC.....	Direct Current	P/N.....	Part Number
EMS.....	Emergency Stop	qt.....	Quarts
ENG.....	Engine	QTY.....	Quantity
FT (ft).....	Feet	REF.....	Reference
GA (Ga).....	Gauge	REV.....	Revision Level
HYD.....	Hydraulic	RH.....	Right Hand
Hz.....	Hertz	SAE.....	Society of Automotive Engineers
ID.....	Inside Diameter	SN.....	Serial Number
in.....	inches	SPEC(S).....	Specifications
ISO.....	International Organization for Standards	T/T.....	Turntable
JIC.....	Joint Industry Council	UGM.....	Universal Ground Module
KG.....	Kilogram	V.....	Volts
L.....	Liter	W.....	Watts
LB.....	Pounds	#.....	Number

10) ILLUSTRATION REFERENCE LETTERS

When necessary, illustrations may contain reference letters that are intended to track information (i. e. hoses, harness) from one point to another or to track visual enlargement of components to show details that may be located in another area on the illustration.

Note: Due to continuous product improvements, JLG Industries, Inc. reserves the right to make specification changes without prior notification. Contact JLG Industries, Inc. for updated information.

TABLE OF CONTENTS

SECTION 1 - FRAME.....	9
FIGURE 1-1. BASE INSTALLATION	10
FIGURE 1-2. DRIVE MOTOR ASSEMBLY	12
FIGURE 1-3. COVERS INSTALLATION - MANUAL TRAY	14
FIGURE 1-4. COVERS INSTALLATION - POWER TRAY	16
FIGURE 1-5. TIE-DOWNS INSTALLATION	18
FIGURE 1-6. BUMPERS INSTALLATION (OPTIONAL)	20
FIGURE 1-7. GUIDE ROLLER INSTALLATION (OPTIONAL)	22
FIGURE 1-8. OBSTRUCTION SENSING PAD INSTALLATION (OPTIONAL)	24
FIGURE 1-9. REMOTE MANUAL DESCENT INSTALLATION (OPTIONAL)	26
SECTION 2 - CONTROLS	29
FIGURE 2-1. PUMP AND MOTOR ASSEMBLY	30
FIGURE 2-2. BATTERIES, ALARM AND STROBE INSTALLATION	34
FIGURE 2-3. BATTERY CHARGER INSTALLATION (WITHOUT CORD REEL)	36
FIGURE 2-4. BATTERY CHARGER INSTALLATION (WITH CORD REEL)	38
FIGURE 2-5. CHARGER PLUG INSTALLATION - CUSTOMER SUPPLIED PLUG	40
FIGURE 2-6. CHARGER PLUG INSTALLATION - 110V PLUG.....	42
FIGURE 2-7. CHARGER PLUG INSTALLATION - 110V IEC YELLOW PLUG (CE & UK CA SPECS)	44
FIGURE 2-8. CHARGER PLUG INSTALLATION - 220V IEC BLUE PLUG (CE & UK CA SPECS)	46
FIGURE 2-9. CHARGER PLUG INSTALLATION - 220V IEC KEYED GROUND PLUG (CE & UK CA SPECS)	48
FIGURE 2-10. CHARGER PLUG INSTALLATION - 220V IEC POST GROUND PLUG (CE & UK CA SPECS)	50
FIGURE 2-11. CHARGER PLUG INSTALLATION - 220V IEC SIDE GROUND PLUG (CE & UK CA SPECS)	52
FIGURE 2-12. CHARGER PLUG INSTALLATION - 220V (AUSTRALIAN SPECS)	54
FIGURE 2-13. GROUND CONTROL AND TRACTION MODULE INSTALLATION (ALL SPECS EXCEPT JAPANESE SPECS)	56
FIGURE 2-14. GROUND CONTROL AND TRACTION MODULE INSTALLATION (CHINESE AND JAPANESE SPECS)	58
FIGURE 2-15. PLATFORM CONTROL BOX ASSEMBLY	60
FIGURE 2-16. CONTROLLER ASSEMBLY	62
SECTION 3 - MAST	65
FIGURE 3-1. MAST INSTALLATION	66
FIGURE 3-2. MAST ASSEMBLY	68
SECTION 4 - PLATFORM	71
FIGURE 4-1. PLATFORM INSTALLATION - WITHOUT GATE LATCH	72
FIGURE 4-2. PLATFORM ASSEMBLY - WITHOUT GATE LATCH	74
FIGURE 4-3. PLATFORM INSTALLATION - WITH GATE LATCH	76
FIGURE 4-4. PLATFORM ASSEMBLY - WITH GATE LATCH	78
FIGURE 4-5. TRAY INSTALLATION - MANUAL	80
FIGURE 4-6. TRAY ASSEMBLY - MANUAL	82
FIGURE 4-7. TRAY INSTALLATION - POWER	84
FIGURE 4-8. PUMP ASSEMBLY - POWER TRAY	88
FIGURE 4-9. CARGO BELT INSTALLATION (OPTIONAL)	90
FIGURE 4-10. FLOORMAT INSTALLATION (OPTIONAL)	92
FIGURE 4-11. SCANNER POCKET INSTALLATION (OPTIONAL)	94
SECTION 5 - CYLINDER	97
FIGURE 5-1. LIFT CYLINDER ASSEMBLY	98
FIGURE 5-2. POWER TRAY CYLINDER ASSEMBLY	100
SECTION 6 - HYDRAULIC	103
FIGURE 6-1. HYDRAULIC SYSTEM INSTALLATION - STANDARD	104
FIGURE 6-2. HYDRAULIC SYSTEM INSTALLATION - FIRE RESISTANT	106
SECTION 7 - ELECTRICAL	109
FIGURE 7-1. CABLES INSTALLATION	110
FIGURE 7-2. ELECTRICAL SYSTEM INSTALLATION - NO BATTERY	112
FIGURE 7-3. DRIVE MOTOR HARNESS	114
FIGURE 7-4. FOOTSWITCH JUMPER HARNESS	116

TABLE OF CONTENTS

FIGURE 7-5. GROUND TO PLATFORM HARNESS	118
FIGURE 7-6. LED AND TEMPERATURE SENSOR HARNESS	120
FIGURE 7-7. PLATFORM BOX POWER HARNESS	122
FIGURE 7-8. PLATFORM CONTROLS HARNESS	124
FIGURE 7-9. TRAY HARNESS.....	126
SECTION 8 - DECALS	129
FIGURE 8-1. COMMON DECALS INSTALLATION - STANDARD PAINT	130
FIGURE 8-2. COMMON DECALS INSTALLATION - SPECIAL PAINT	132
FIGURE 8-3. DECAL INSTALLATION - ANSI SPECS (ENGLISH LANGUAGE) (MANUAL TRAY)	134
FIGURE 8-4. DECAL INSTALLATION - ANSI SPECS (ENGLISH LANGUAGE) (POWER TRAY)	136
FIGURE 8-5. DECAL INSTALLATION - AUSTRALIAN SPECS (ENGLISH LANGUAGE) (MANUAL TRAY)	138
FIGURE 8-6. DECAL INSTALLATION - AUSTRALIAN SPECS (ENGLISH LANGUAGE) (POWER TRAY)	140
FIGURE 8-7. DECAL INSTALLATION - BRAZIL SPECS (PORTUGUESE LANGUAGE) (MANUAL TRAY)	142
FIGURE 8-8. DECAL INSTALLATION - BRAZIL SPECS (PORTUGUESE LANGUAGE) (POWER TRAY)	144
FIGURE 8-9. DECAL INSTALLATION - CE & UK CA SPECS (ENGLISH LANGUAGE) (MANUAL TRAY)	146
FIGURE 8-10. DECAL INSTALLATION - CE & UK CA SPECS (ENGLISH LANGUAGE) (POWER TRAY)	148
FIGURE 8-11. DECAL INSTALLATION - CHINA SPECS (CHINESE LANGUAGE) (MANUAL TRAY)	150
FIGURE 8-12. DECAL INSTALLATION - CHINA SPECS (CHINESE LANGUAGE) (POWER TRAY)	152
FIGURE 8-13. DECAL INSTALLATION - CSA SPECS (FRENCH LANGUAGE) (MANUAL TRAY)	154
FIGURE 8-14. DECAL INSTALLATION - CSA SPECS (FRENCH LANGUAGE) (POWER TRAY)	156
FIGURE 8-15. DECAL INSTALLATION - JAPAN SPECS (JAPANESE LANGUAGE) (MANUAL TRAY)	158
FIGURE 8-16. DECAL INSTALLATION - JAPAN SPECS (JAPANESE LANGUAGE) (POWER TRAY)	160
FIGURE 8-17. DECAL INSTALLATION - LATIN AMERICAN SPECS (SPANISH LANGUAGE) (MANUAL TRAY)	162
FIGURE 8-18. DECAL INSTALLATION - LATIN AMERICAN SPECS (SPANISH LANGUAGE) (POWER TRAY)	164
SECTION 9 - RECOMMENDED SERVICE PARTS STOCK	167
FIGURE 9-1. RECOMMENDED SERVICE PARTS STOCK	168
SECTION 10 - SPECIAL OPTIONS/ACCESSORIES/KITS	169
FIGURE 10-1. SPECIAL OPTIONS/ACCESSORIES/KITS	170
PART NUMBER INDEX.....	171

SECTION 1 - FRAME

SECTION 1 - FRAME

FIGURE 1-1. BASE INSTALLATION

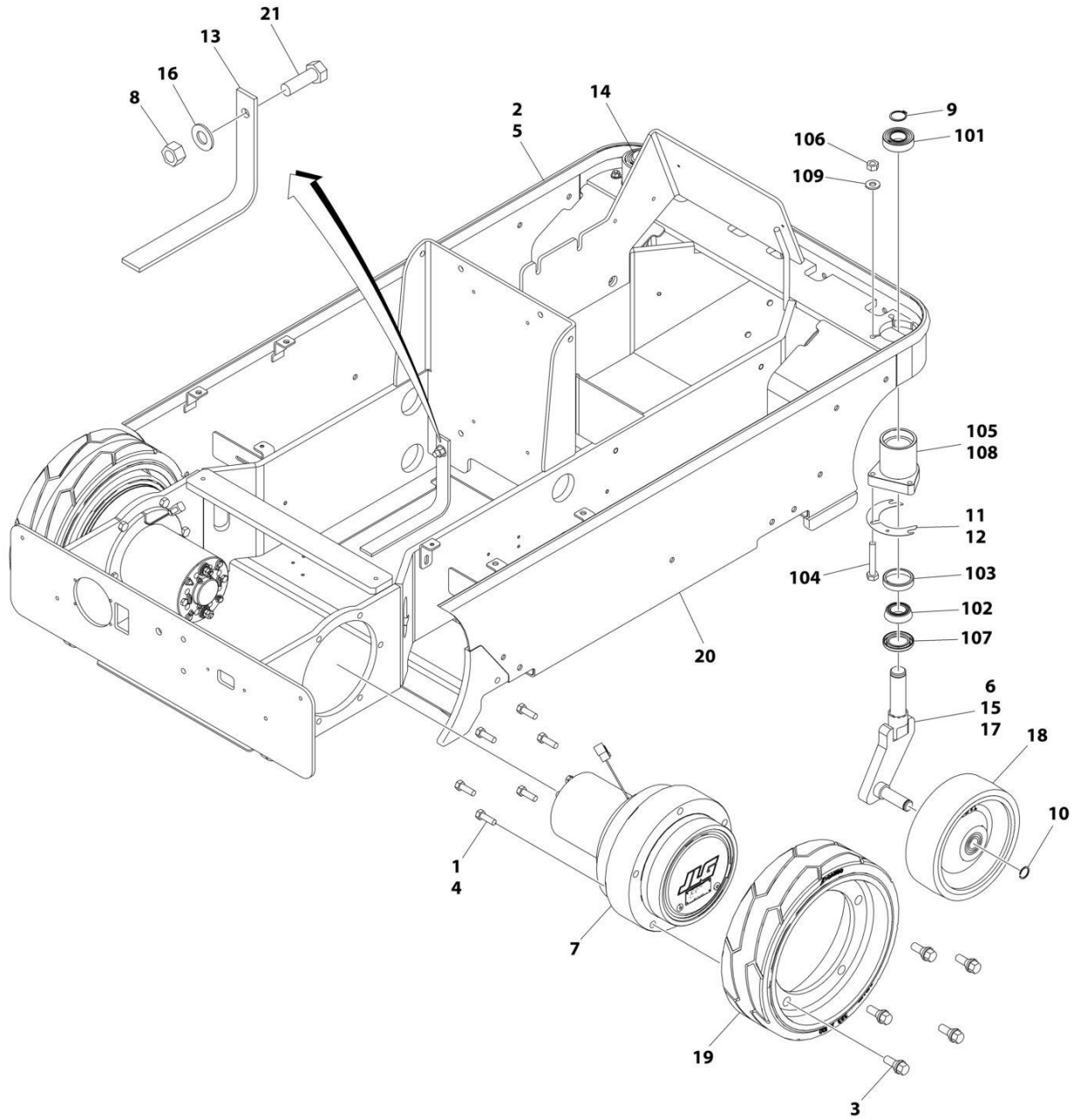

ART_1001228849

SECTION 1 - FRAME

FIGURE 1-1. BASE INSTALLATION

ITEM	PART NUMBER	QTY	DESCRIPTION	REV
	1001228849	Ref	BASE INSTALLATION	C
1	0100011	AR	Compound, Locking	
2	0100081	AR	Compound, Locking	
3	0630580	10	Bolt, Wheel	
4	0641609	12	Bolt 3/8 x 1-1/8	
5	0940132	1	Bumper, Chassis	
6	3020039	AR	Lubricant	
7	1001229310	2	Drive Motor Assembly (See Separate Breakdown in this Section)	
8	3311605	1	Nut 3/8	
9	3760115	2	Ring, Retaining	
10	3760496	2	Ring, Retaining	
11	4071113	AR	Shim .015	
12	4071114	AR	Shim .036	
13	4240147	1	Strap, Static	
14	4520342	1	Spindle (Left Side)	
15	4520343	1	Spindle (Right Side)	
16	4711600	1	Washer 3/8	
17	8882970	AR	Lubricant	
18	1001098810	2	Tire and Wheel Assembly	
19	1001114467	2	Tire and Wheel Assembly	
20	1001228850	NLA	Caster Assembly (Not Available - Purchase Individual Components)(Includes Items 101-109)	
21	0641607	1	Bolt 3/8 x 7/8	
	1001228850	Ref	CASTER ASSEMBLY	B
101	0440306	2	Bearing, Ball	
102	0440307	2	Bearing, Roller	
103	0440308	2	Bearing, Race	
104	0641413	6	Bolt 1/4 x 1-5/8	
104	0641414	6	Bolt 1/4 x 1-3/4	
105	3020029	AR	Grease	
106	3271405	6	Nut 1/4	
107	3960590	2	Seal	
108	4341155	2	Mount, Caster	
109	4711400	6	Washer 1/4	

SECTION 1 - FRAME

FIGURE 1-2. DRIVE MOTOR ASSEMBLY

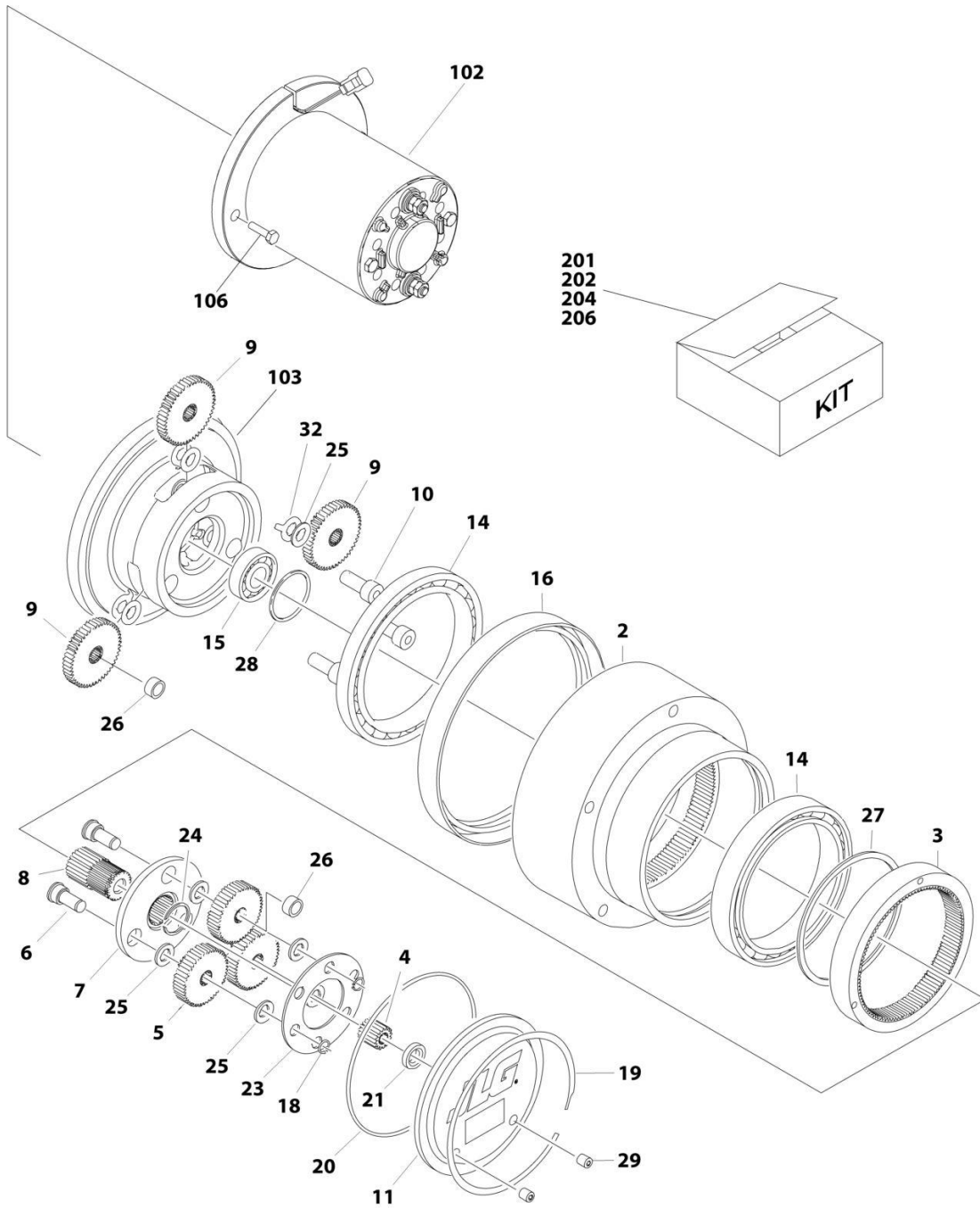

ART_1001229310

SECTION 1 - FRAME

FIGURE 1-2. DRIVE MOTOR ASSEMBLY

ITEM	PART NUMBER	QTY	DESCRIPTION	REV
	1001229310	Ref	DRIVE MOTOR ASSEMBLY	A
		Ref	HUB ASSEMBLY	
1	See Note	NSS	Spindle (Note: Purchase Complete Assembly)	
2	See Note	NSS	Hub (Note: Use Item 206)	
3	See Note	NSS	Ring, Input (Note: Use Item 204)	
4	70007194	1	Gear, Input Sun	
5	70007198	3	Gear, Input Planet	
6	70007196	3	Pin, Planet Gear	
7	70007197	1	Carrier	
8	70007195	1	Gear, Output Sun	
9	70007193	3	Gear, Output Planet (Includes Item 26)	
10	70007199	3	Pin, Output Planet	
11	See Note	NSS	Cover (Note: Use Item 201)	
14	See Note	NSS	Bearing, Main (Note: Use Item 202, 204 or 206)	
15	70007200	1	Bearing, Shaft	
16	See Note	NSS	Seal, Lip (Note: Use Item 202 or 206)	
17	7024786	1	Seal, Lip	
18	70007204	3	Ring, Retaining	
19	See Note	NSS	Ring, Retaining (Note: Use Item 201)	
20	See Note	NSS	O-Ring (Note: Use Item 201)	
21	See Note	NSS	Washer, Thrust (Note: Use Item 201)	
23	70007207	1	Plate, Thrust	
24	70007203	1	Ring, Retaining	
25	70007206	9	Washer, Thrust	
26	70007201	3	Bushing	
27	See Note	NSS	Ring, Retaining (Note: Use Item 204 or 206)	
28	70007202	1	Ring, Retaining	
29	See Note	NSS	Plug (Note: Use Item 201)	
32	70007205	3	Washer, Tanged	
		Ref	BRAKE AND MOTOR	
102	70007192	1	Motor, Electric	
103	70007190	1	Brake, Input	
106	70007191	2	Bolt M6 x 20	
		Ref	KIT OPTIONS	
201	7024747	1	Cover Kit (Includes Items 11, 19, 20, 21 & 29)	
202	7024748	1	Main Seal Kit (Includes Qty 1 of Items 14, 16 & 20)	
204	7024758	1	Input Ring Kit (Includes Items 3, 20, 27 & Qty 1 of Item 14)	
206	7024756	1	Hub Kit (Includes Items 2, 16, 20, 27 & Qty 1 of Item 14)	

SECTION 1 - FRAME

FIGURE 1-3. COVERS INSTALLATION - MANUAL TRAY

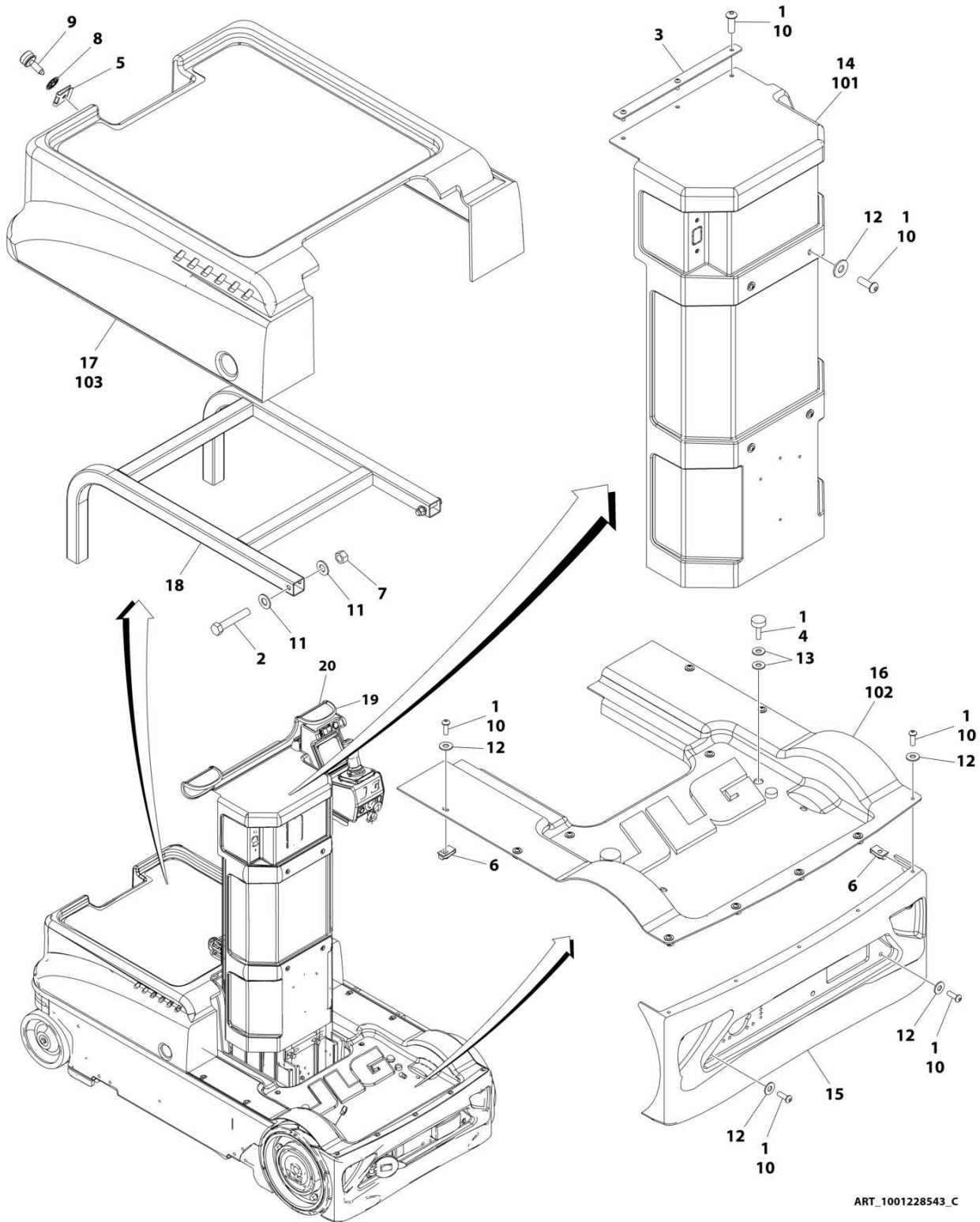

ART_1001228543_C

SECTION 1 - FRAME

FIGURE 1-3. COVERS INSTALLATION - MANUAL TRAY

ITEM	PART NUMBER	QTY	DESCRIPTION	REV
	1001228543	Ref	COVERS INSTALLATION	D
1	0100011	AR	Compound, Locking	
2	0641617	2	Bolt 3/8 x 2-1/8	
3	1001229778	1	Bracket	
4	0940049	2	Stopper	
5	1380169	1	Clip	
6	3300454	9	Nut, Tinnerman 1/4	
7	3311605	2	Nut 3/8	
8	3760308	1	Retainer	
9	3900174	1	Screw, Thumb	
10	3900258	22	Screw 1/4 x 3/4	
11	4711600	4	Washer 3/8	
12	4751400	19	Washer 1/4	
13	4740139	4	Washer	
14	1001228538	1	Cover, Mast	
15	1001228539	1	Cover, Rear Bumper	
16	1001228540	1	Cover, Battery	
17	1001228541	1	Cover, Front	
18	1001228852	1	Support	
19	4060805	AR	Shield, Flex Trim	
20	1001234322	1	Plate, Platform Controls Guard	
100	1001233045	1	Kit, Hood / Covers, with OSS (10MSP)	
101	1001228538	NSS	Cover, Mast	
102	1001228540	NSS	Cover, Battery and Frame	
103	1001228541	NSS	Hood, Front Cover Assembly	

SECTION 1 - FRAME

FIGURE 1-4. COVERS INSTALLATION - POWER TRAY

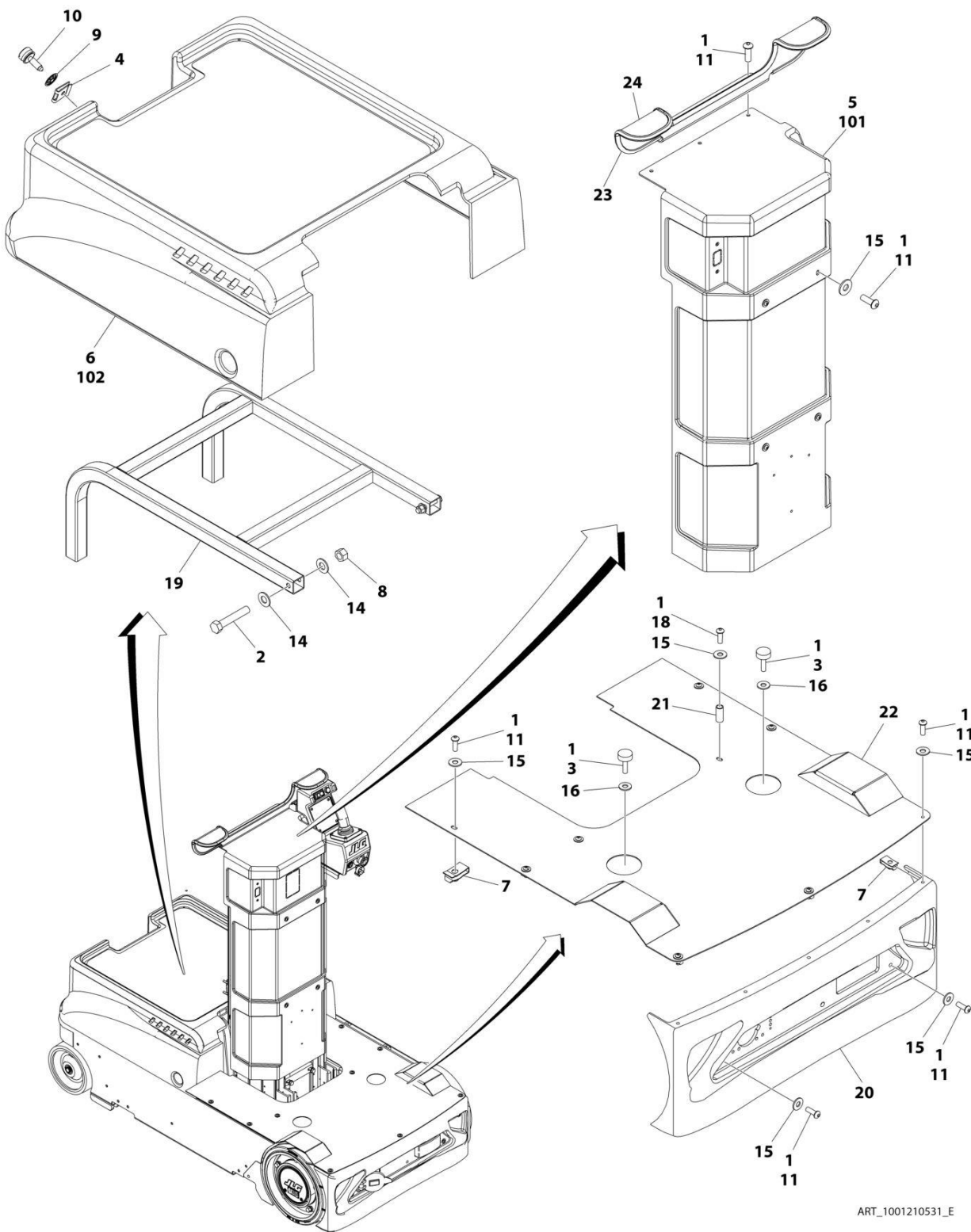

ART_1001210531_E

SECTION 1 - FRAME

FIGURE 1-4. COVERS INSTALLATION - POWER TRAY

ITEM	PART NUMBER	QTY	DESCRIPTION	REV
	1001210531	Ref	COVERS INSTALLATION	E
1	0100011	AR	Compound, Locking	
2	0641617	2	Screw 3/8 x 2-1/8	
3	0940049	2	Stopper	
4	1380169	1	Clip	
5	1001228538	1	Cover, Mast	
6	1001228541	1	Cover, Front	
7	3300454	9	Nut, Tinnerman 1/4	
8	3311605	2	Nut 3/8	
9	3760308	1	Retainer	
10	3900174	1	Screw, Thumb	
11	3900258	16	Screw 1/4 x 3/4	
14	4711600	4	Washer 3/8	
15	4751400	15	Washer 1/4	
16	4740139	2	Washer	
18	3911432	2	Screw 1/4 x 2	
19	1001228852	1	Support	
20	1001228539	1	Cover, Rear Bumper	
21	1001157665	2	Tube, Spacer	
22	1001171824	1	Cover, Battery	
23	4060805	AR	Shield, Flex Trim	
24	1001234322	1	Plate, Platform Controls Guard	
100	1001233046	1	Kit, Hood / Covers, with OSS (10MSP)	
101	See Note	NSS	Cover, Mast (Note: Use Item 100)	
102	See Note	NSS	Hood, Front Cover Assembly (Note: Use Item 100)	

SECTION 1 - FRAME

FIGURE 1-5. TIE-DOWNS INSTALLATION

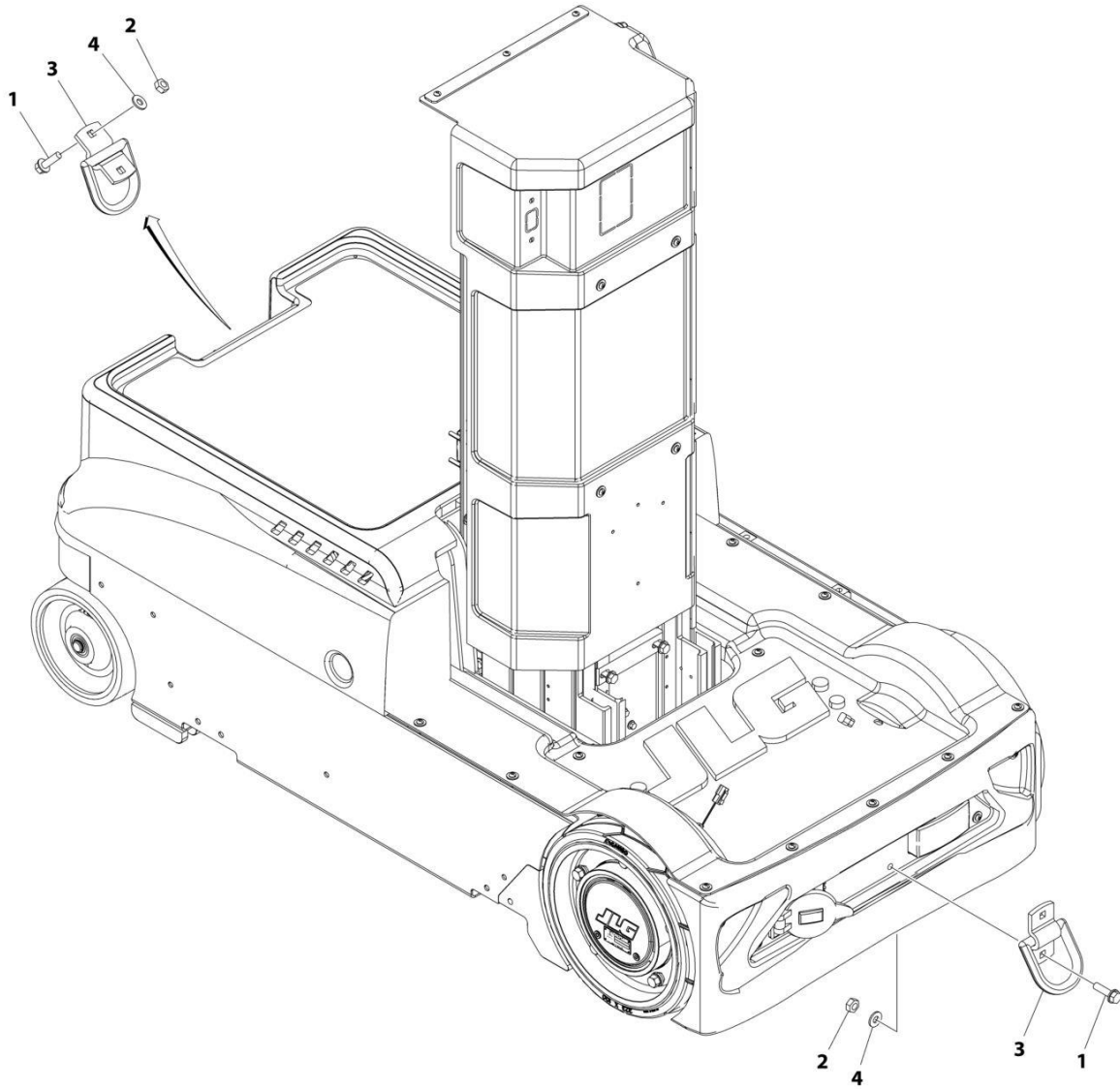

ART_0240114

SECTION 1 - FRAME

FIGURE 1-5. TIE-DOWNS INSTALLATION

ITEM	PART NUMBER	QTY	DESCRIPTION	REV
	0240114	Ref	TIE-DOWNS INSTALLATION	A
1	0811610	4	Screw 3/8 x 1-1/4	
2	3311605	4	Nut 3/8	
3	3760365	2	Tie-Ring	
4	4711600	4	Washer 3/8	

SECTION 1 - FRAME

FIGURE 1-6. BUMPERS INSTALLATION (OPTIONAL)

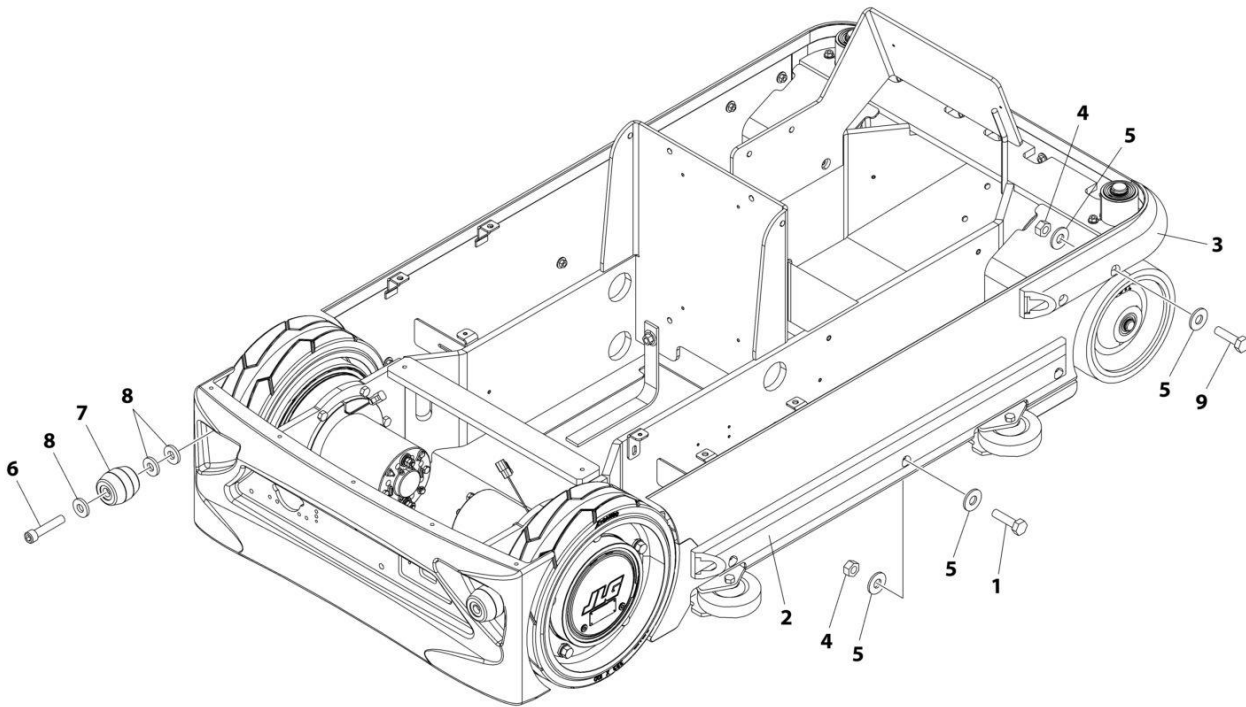

ART_0274078_F

SECTION 1 - FRAME

FIGURE 1-6. BUMPERS INSTALLATION (OPTIONAL)

ITEM	PART NUMBER	QTY	DESCRIPTION	REV
	0274078	Ref	BUMPERS INSTALLATION	F
1	0641408	6	Bolt 1/4 x 1	
2	0940152	2	Bumper, Side	
3	1001204273	2	Bumper, Front	
4	3311405	AR	Nut 1/4	
5	4751400	AR	Washer 1/4	
6	3931420	2	Capscrew 1/4 x 1-1/4	
7	4160187	2	Spring, Rubber	
8	4891400	6	Washer 1/4	
9	0641410	8	Bolt 1/4 x 1-1/4	

SECTION 1 - FRAME

FIGURE 1-7. GUIDE ROLLER INSTALLATION (OPTIONAL)

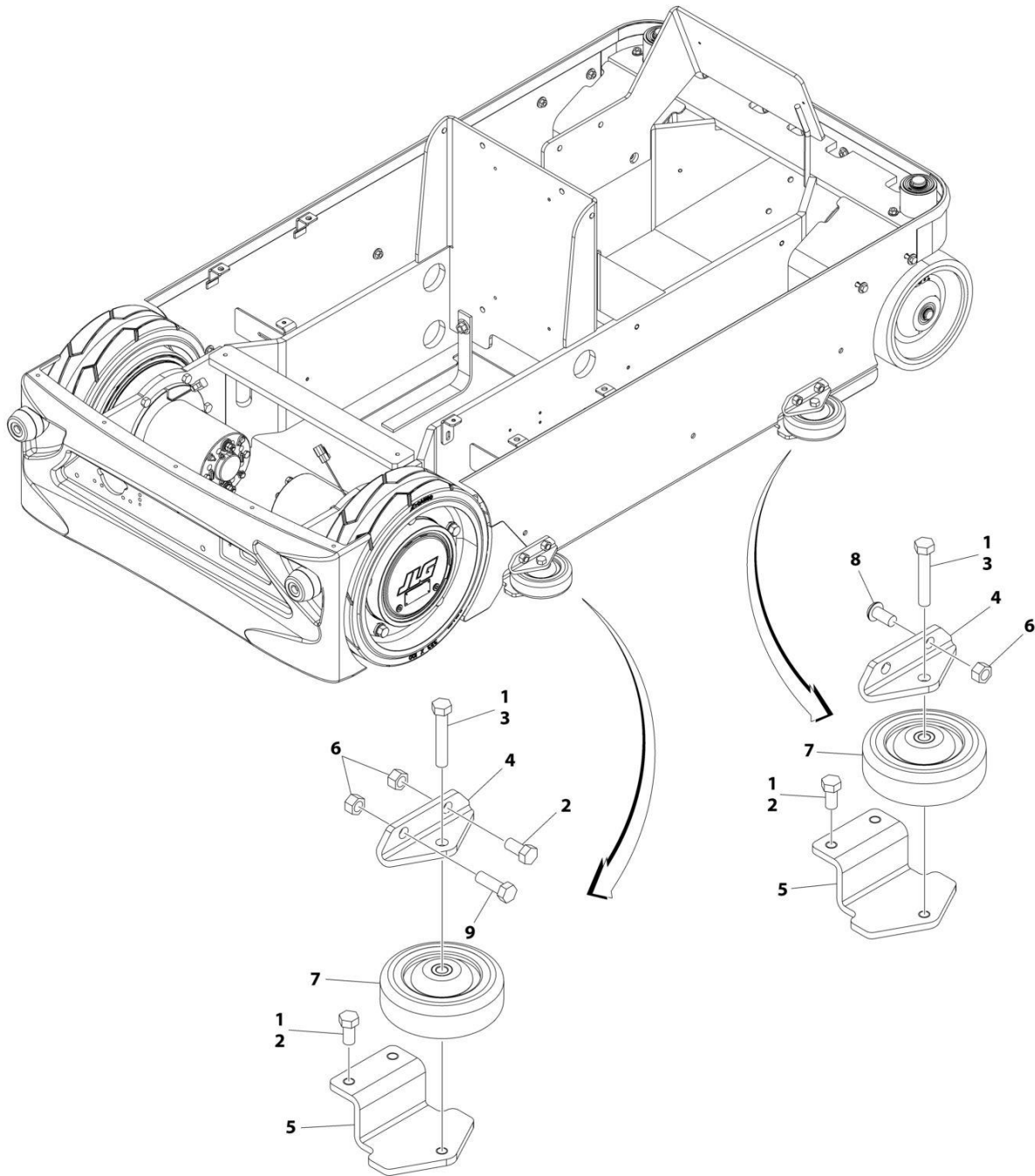

ART_0240103

SECTION 1 - FRAME

FIGURE 1-7. GUIDE ROLLER INSTALLATION (OPTIONAL)

ITEM	PART NUMBER	QTY	DESCRIPTION	REV
	0240103	Ref	GUIDE ROLLER INSTALLATION	B
1	0100011	AR	Compound, Locking	
2	0641606	10	Bolt 3/8 x 3/4	
3	0641617	4	Bolt 3/8 x 2-1/8	
4	0903120	4	Bracket, Top Roller	
5	0903121	4	Bracket, Bottom Roller	
6	3311605	8	Nut 3/8	
7	4520352	4	Wheel	
8	3900283	4	Screw 3/8 x 3/4	
9	0641609	2	Bolt 3/8 x 1-1/8	

SECTION 1 - FRAME

FIGURE 1-8. OBSTRUCTION SENSING PAD INSTALLATION (OPTIONAL)

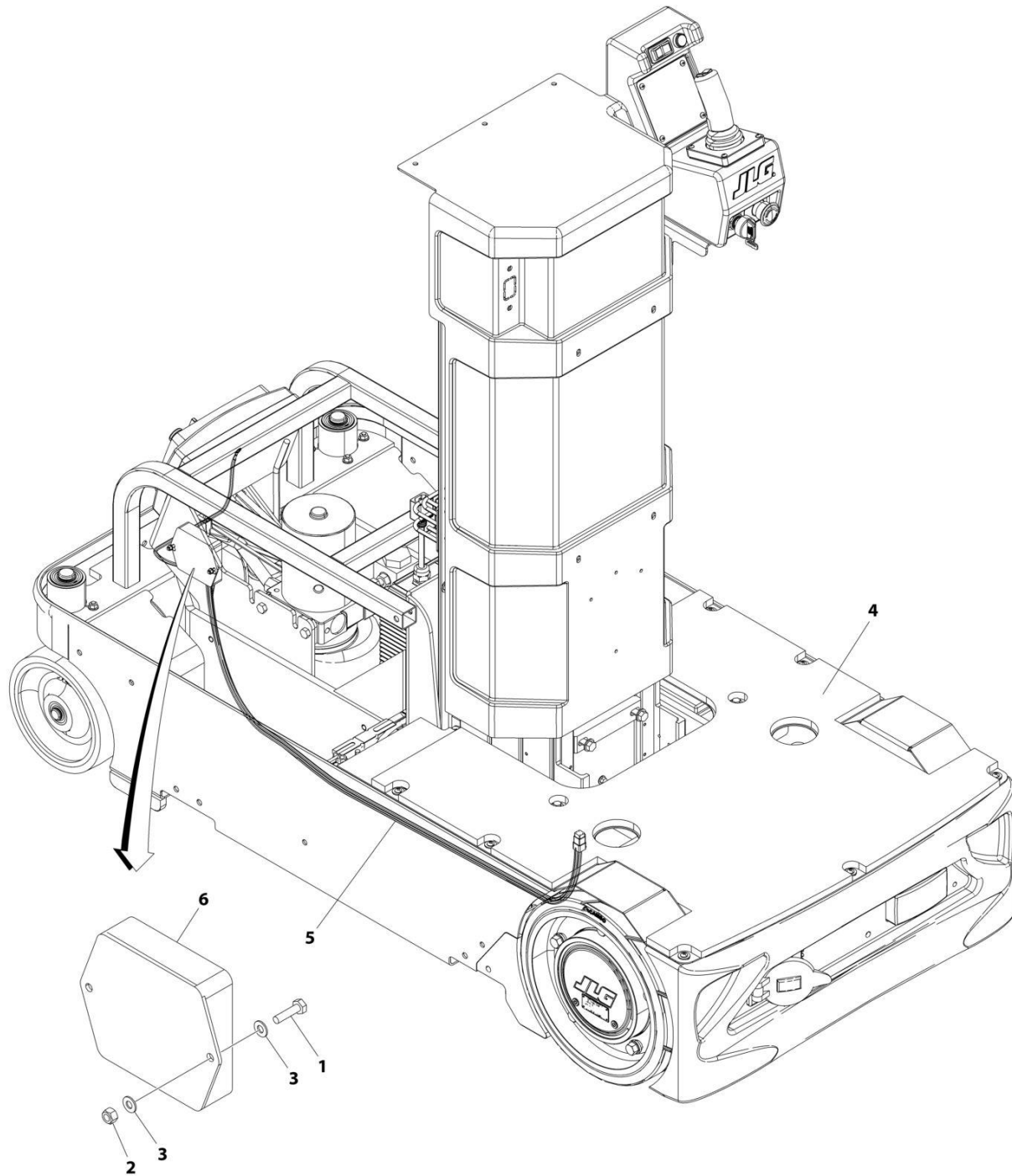

ART_1001210574

SECTION 1 - FRAME

FIGURE 1-8. OBSTRUCTION SENSING PAD INSTALLATION (OPTIONAL)

ITEM	PART NUMBER	QTY	DESCRIPTION	REV
	1001210574	Ref	OBSTRUCTION SENSING PAD INSTALLATION	A
1	0760408	2	Bolt M4 x 16	
2	3290405	2	Nut M4	
3	4811400	4	Washer M4	
4	1001210573	1	Pad, Obstruction Switch	
5	1001228994	1	Sensing Pad Harness	
6	1001229990	1	Relay	

SECTION 1 - FRAME

FIGURE 1-9. REMOTE MANUAL DESCENT INSTALLATION (OPTIONAL)

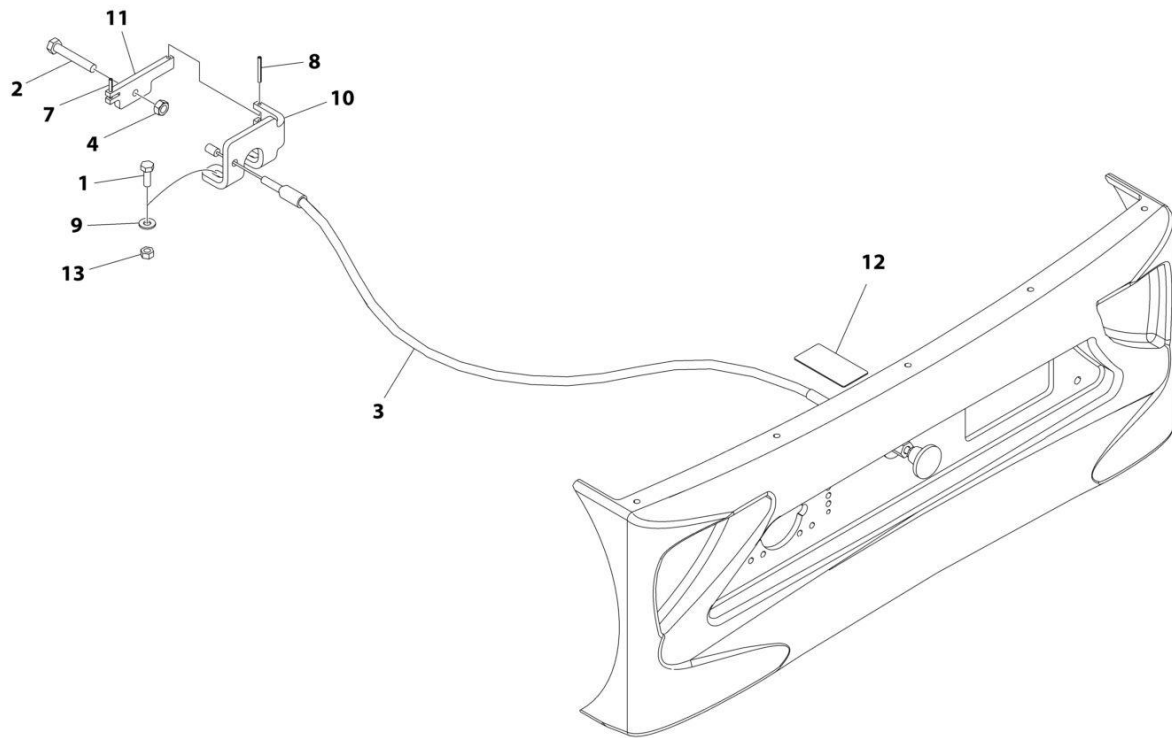

ART_1001206177_D

SECTION 1 - FRAME

FIGURE 1-9. REMOTE MANUAL DESCENT INSTALLATION (OPTIONAL)

ITEM	PART NUMBER	QTY	DESCRIPTION	REV
	1001206177	Ref	REMOTE MANUAL DESCENT INSTALLATION	D
1	0641406	2	Bolt 1/4 x 3/4	
2	0760818	1	Bolt M8 x 50	
3	1001229725	1	Cable, Release	
4	3290801	1	Nut M8	
7	3440410	1	Rollpin	
8	3440418	1	Rollpin	
9	4711400	2	Washer 1/4	
10	1001201909	1	Bracket	
11	1001201910	1	Plate	
12	1001206261	1	Decal - Manual Descent	
13	3321402	2	Nut 1/4	

SECTION 2 - CONTROLS

SECTION 2 - CONTROLS

FIGURE 2-1. PUMP AND MOTOR ASSEMBLY

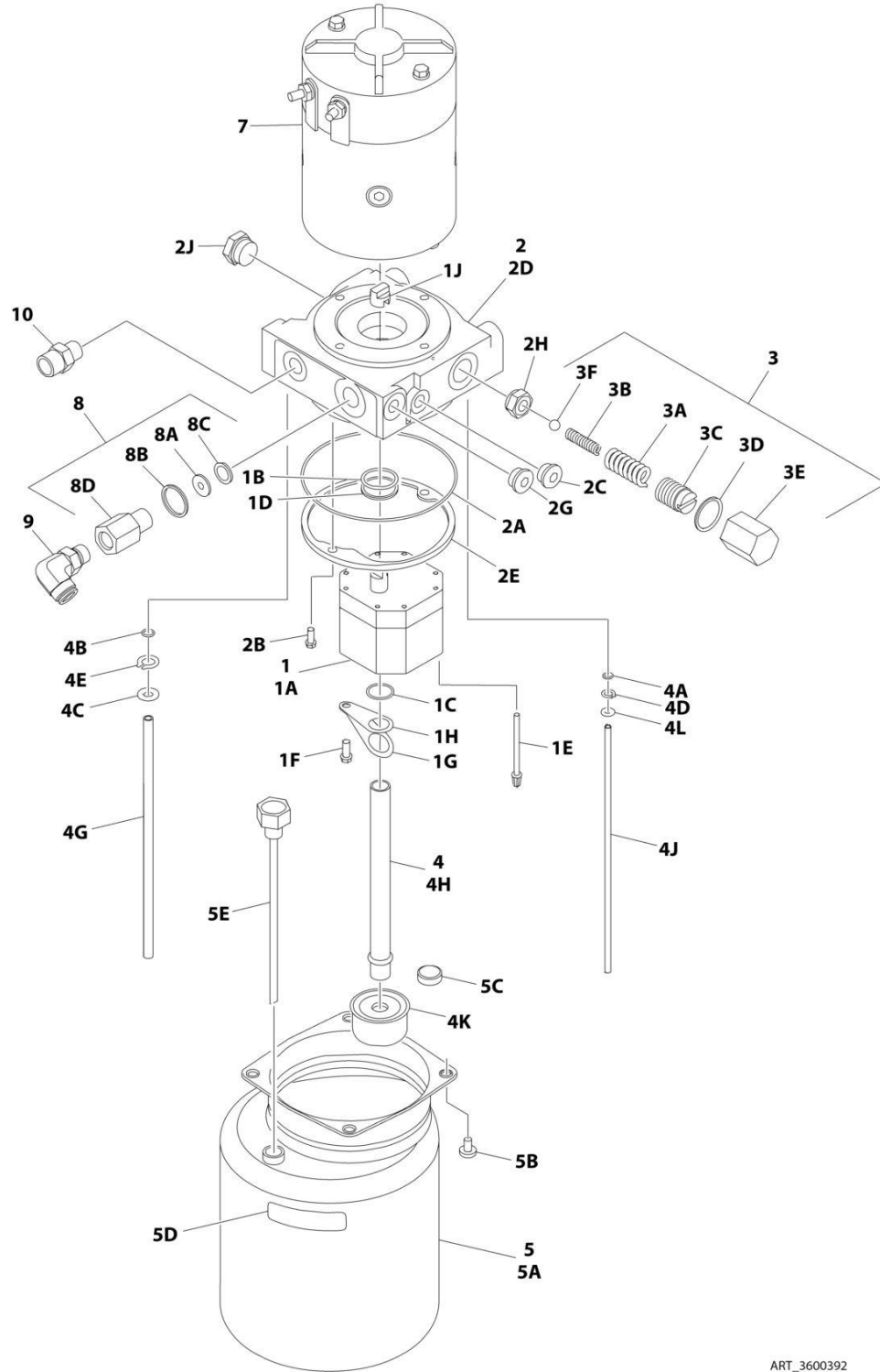

ART_3600392

SECTION 2 - CONTROLS

FIGURE 2-1. PUMP AND MOTOR ASSEMBLY

ITEM	PART NUMBER	QTY	DESCRIPTION	REV
	3600392	Ref	PUMP AND MOTOR ASSEMBLY	D
1	7027943	Ref	Pump Components Kit	
1A	See Note	NSS	Pump (Note: Use Item 1)	
1B	7027943	1	Seal	
1C	7011021	1	Seal	
1D	See Note	NSS	Seal (Note: Use Item 1)	
1E	7010928	4	Screw	
1F	7011033	1	Screw	
1G	See Note	NSS	Lockwasher (Note: Use Item 1)	
1H	See Note	NSS	Retainer (Note: Use Item 1)	
1J	7011016	1	Coupler	
2	7027944	Ref	Adaptor Components Kit	
2A	7011025	1	Seal	
2B	7011011	2	Screw	
2C	See Note	NSS	Plug (Note: Use Item 2)	
2D	See Note	NSS	Adaptor (Note: Use Item 2)	
2E	7011013	1	Retainer	
2F	See Note	NSS	Plug, Plastic (Not Shown) (Note: Use Item 2)	
2G	See Note	NSS	Plug, Steel (Note: Use Item 2)	
2H	See Note	NSS	Seat Assembly (Note: Use item 2)	
2J	See Note	NSS	Plug (Note: Use Item 2)	
3	7027945	Ref	Relief Valve Components Kit	
3A	7011008	1	Spring	
3B	7011017	1	Spring	
3C	7011009	1	Screw, Adjustment	
3D	See Note	NSS	Gasket (Note: Use Item 3)	
3E	7011004	1	Cap	
3F	See Note	NSS	Ball (Note: Use Item 3)	
4	7027946	Ref	Tube Components Kit	
4A	7011024	1	Seal	
4B	See Note	NSS	Seal (Note: Use Item 4)	
4C	See Note	NSS	Washer (Note: Use Item 4)	
4D	7011031	1	Ring, Retaining	
4E	7011032	1	Ring, Retaining	
4G	See Note	NSS	Tube (Note: Use Item 4)	
4H	See Note	NSS	Tube (Note: Use Item 4)	
4J	See Note	NSS	Tube (Note: Use Item 4)	
4K	7011029	1	Strainer	
4L	7011034	1	Spacer	
5	7027947	Ref	Tank Components Kit	
5A	See Note	NSS	Tank (Note: Use Item 5)	
5B	See Note	NSS	Screw (Note: Use Item 5)	
5C	7011027	1	Magnet	
5D	See Note	NSS	Label (Note: Use Item 5)	
5E	7011069	1	Breather/Dipstick	
6	See Note	1	Label (Not Shown) (Note: Not Available for Purchase)	
7	7027948	1	Motor Assembly	
7	See Note	NSS	Brush Kit (Note: Use Item 7)	
8	7027949	Ref	Return Port Components Kit	
8A	See Note	NSS	Seal (Note: Use Item 8)	

SECTION 2 - CONTROLS

ITEM	PART NUMBER	QTY	DESCRIPTION	REV
8B	See Note	NSS	Seal (Note: Use Item 8)	
8C	See Note	NSS	Washer (Note: Use Item 8)	
8D	See Note	NSS	Body, Return Port (Note: Use Item 8)	
9	2221185	1	Fitting, 90	
10	2110606	1	Fitting, Straight	

SECTION 2 - CONTROLS

FIGURE 2-2. BATTERIES, ALARM AND STROBE INSTALLATION

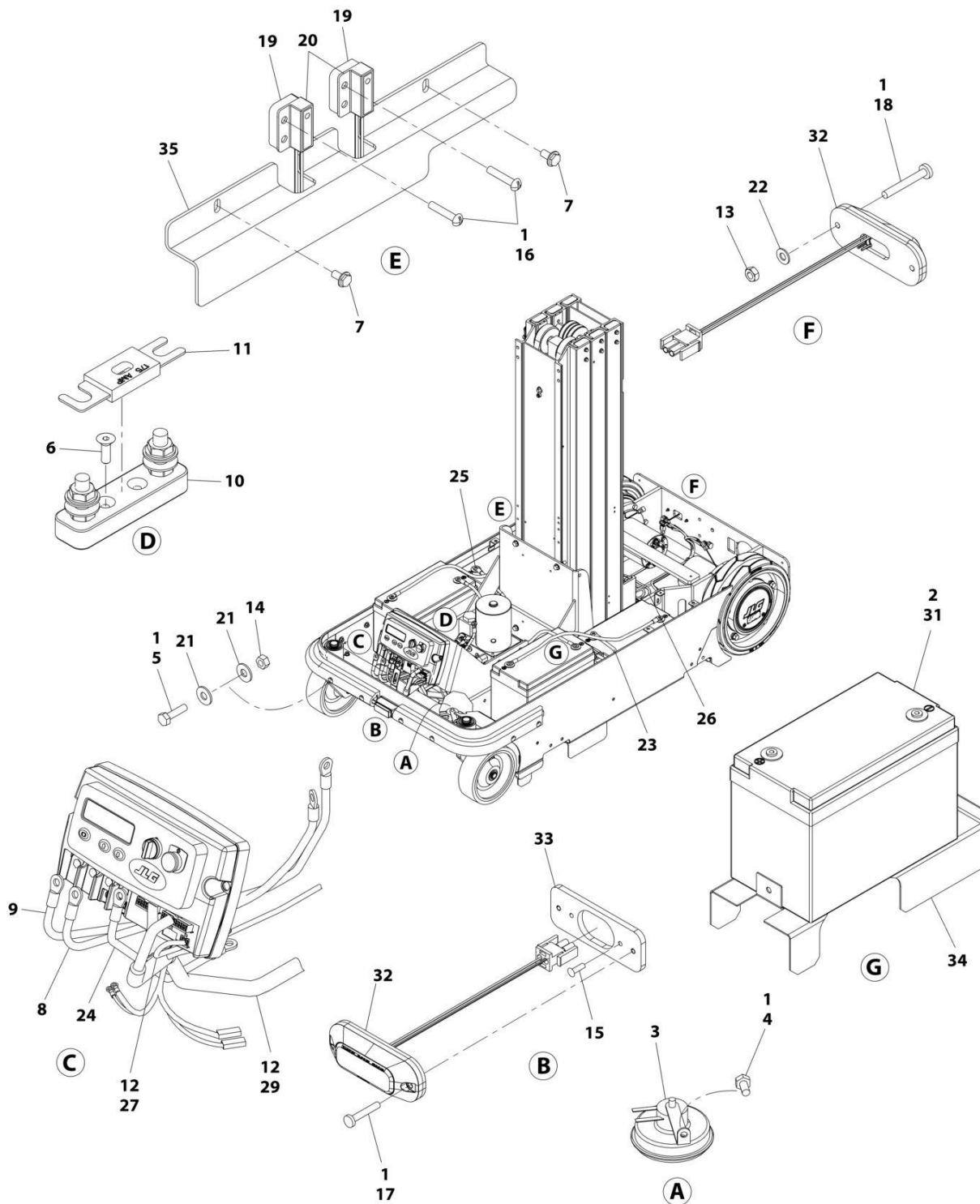

ART_1001229682_B

SECTION 2 - CONTROLS

FIGURE 2-2. BATTERIES, ALARM AND STROBE INSTALLATION

ITEM	PART NUMBER	QTY	DESCRIPTION	REV
	1001229682	Ref	BATTERIES, ALARM AND STROBE INSTALLATION	C
1	0100011	AR	Compound, Locking	
2	0100051	AR	Grease, Terminal	
3	0140022	1	Alarm	
4	0641404	1	Bolt 1/4 x 1/2	
5	0641408	8	Bolt 1/4 x 1	
6	0741005	2	Screw #10 x 5/8	
7	0791003	2	Screw #10 x 3/8	
8	1060943	1	Cable (GSM P+ to Pump+)	
9	1060944	1	Cable (GSM P- to Pump-)	
10	2400044	1	Fuse, Mounting Block	
11	2400069	1	Fuse 175Amp	
12	3020038	AR	Grease, Contact	
13	3290401	2	Nut M4	
14	3311405	8	Nut 1/4	
15	3820013	2	Rivet	
16	3931016	4	Screw 10-24 x 1	
17	4031509	2	Screw M4 x 25	
18	4031511	2	Screw M4 x 35	
19	4071084	2	Shim	
20	4360514	2	Switch, Proximity	
21	4751400	16	Washer 1/4	
22	4811400	2	Washer M4	
23	4923022	1	Cable (B+ to Fuse)	
24	4923023	1	Cable (Fuse to GSM)	
25	4923024	1	Cable (B- to GSM)	
26	4923028	1	Traction Module Power Harness	
27	4923029	1	Ground Station to Traction Module Harness	
28	4923383	1	Drive Motor Harness (Not Shown) (See Separate Breakdown in ELECTRICAL SECTION)	
29	4923446	1	Main (MSP) Harness	
30	1001121700	3	Cable (Battery B+ to B-) (Not Shown)	
31	1001177558	4	Battery	
32	1001187862	NLA	Light, Strobe (use PN1001258016)	
32	1001258016	2	Light, Strobe LED	
33	1001207630	NLA	Plate (use PN1001258436)	
33	1001258436	1	Plate	
34	1001229683	2	Plate	
35	1001229684	1	Shield, Wire	

SECTION 2 - CONTROLS

FIGURE 2-3. BATTERY CHARGER INSTALLATION (WITHOUT CORD REEL)

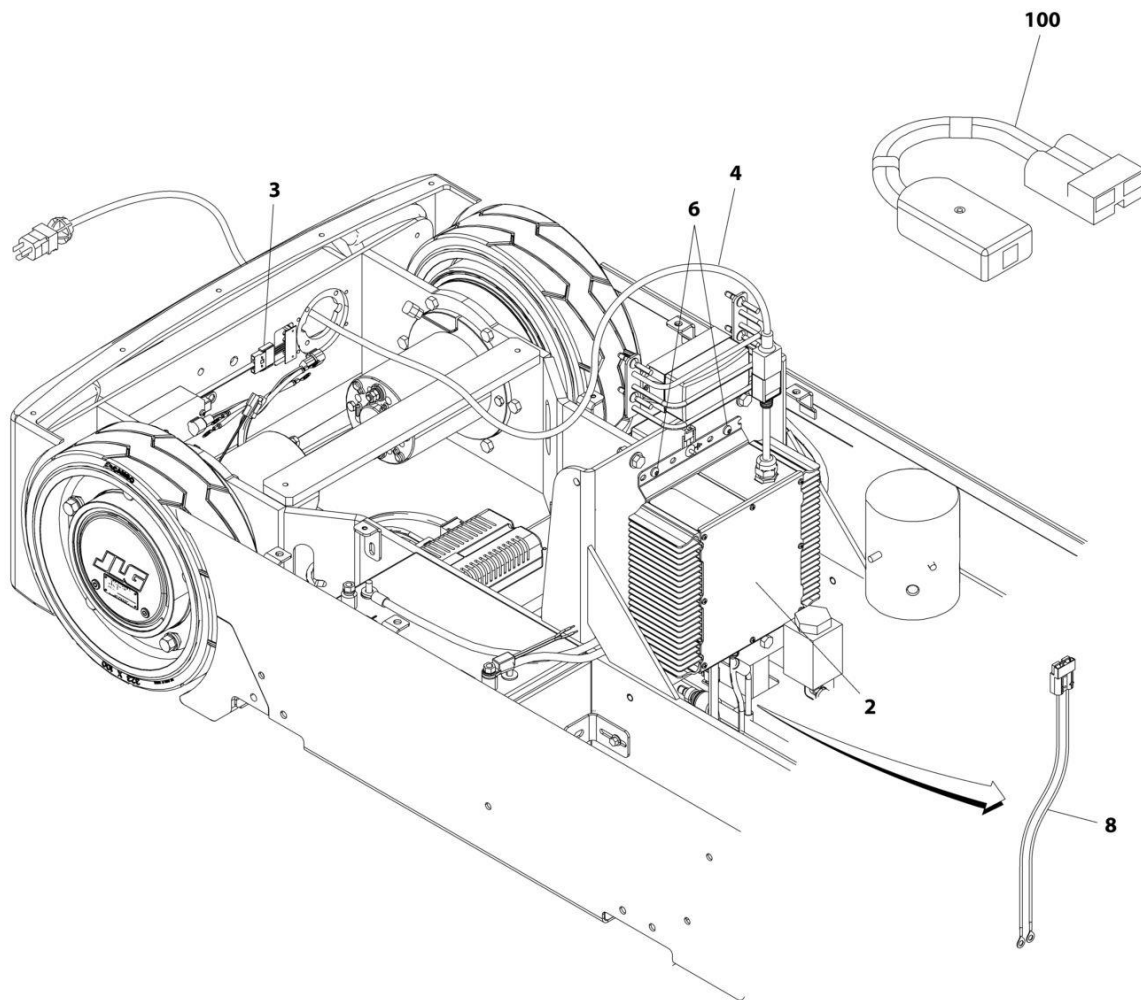

ART_0274898

SECTION 2 - CONTROLS

FIGURE 2-3. BATTERY CHARGER INSTALLATION (WITHOUT CORD REEL)

ITEM	PART NUMBER	QTY	DESCRIPTION	REV
	0274898	Ref	BATTERY CHARGER INSTALLATION	F
		Ref	Note: Available on all Specs.	
2	1001136381	1	Battery Charger Assembly (No Serviceable Parts Available)	
3	0610131	1	LED, Board	
4	1060689	1	Cord, Electrical	
6	4191706	4	Screw M6 x 12	
8	4923438	1	Battery Charger Harness	
9	1001109821	1	LED and Temperature Sensor Harness (Not Shown) (See Separate Breakdown in ELECTRICAL SECTION)	
100	1600466	1	BATTERY CHARGER REPROGRAM CONTROLLER KIT (Use p/n 2915230)	

SECTION 2 - CONTROLS

FIGURE 2-4. BATTERY CHARGER INSTALLATION (WITH CORD REEL)

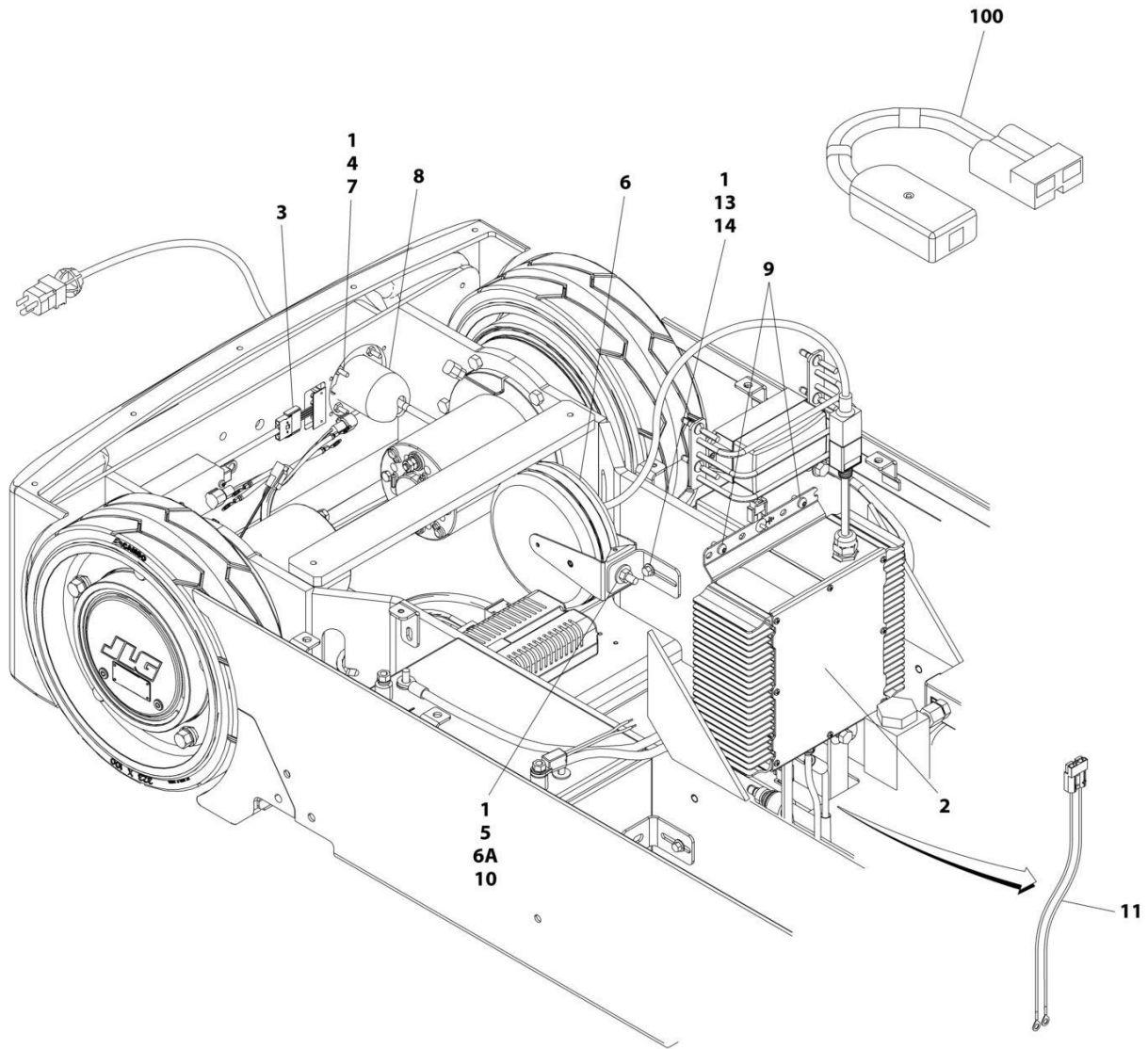

ART_0274900

SECTION 2 - CONTROLS

FIGURE 2-4. BATTERY CHARGER INSTALLATION (WITH CORD REEL)

ITEM	PART NUMBER	QTY	DESCRIPTION	REV
	0274900	Ref	BATTERY CHARGER INSTALLATION	F
		Ref	Note: Available on ANSI, ANSI Export and CSA Specs.	
1	0100011	AR	Compound, Locking	
2	1001136381	1	Battery Charger Assembly (No Serviceable Parts Available)	
3	0610131	1	LED Board	
4	3311001	4	Nut #10	
5	3311501	1	Nut 5/16	
6	3680057	1	Reel, Charger Cord	
6A	0791508	1	Screw 5/16 x 1	
7	3911016	4	Screw #10 x 1	
8	4120046	1	Terminal, Inlet Socket, Cord Reel Stop	
9	4191706	4	Screw M6 x 12	
10	4751500	1	Washer 5/16	
11	4923438	1	Battery Charger Harness	
12	1001109821	1	LED and Temperature Sensor Harness (Not Shown) (See Separate Breakdown in ELECTRICAL SECTION)	
100	1600466	1	BATTERY CHARGER REPROGRAM CONTROLLER KIT (Use p/n 2915230)	

SECTION 2 - CONTROLS

FIGURE 2-5. CHARGER PLUG INSTALLATION - CUSTOMER SUPPLIED PLUG

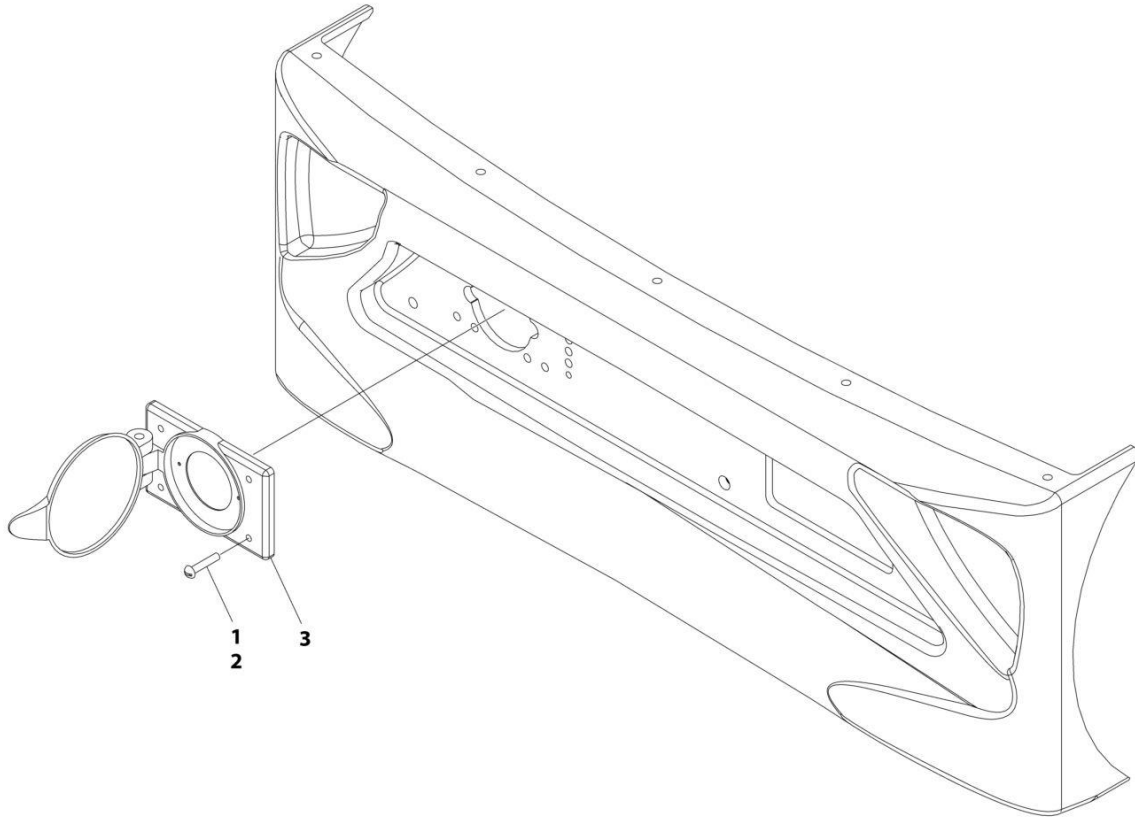

ART_1001097456

SECTION 2 - CONTROLS

FIGURE 2-5. CHARGER PLUG INSTALLATION - CUSTOMER SUPPLIED PLUG

ITEM	PART NUMBER	QTY	DESCRIPTION	REV
	1001097456	Ref	CHARGER PLUG INSTALLATION	A
1	0100011	AR	Compound, Locking	
2	3911016	4	Screw #10 x 1	
3	4460802	1	Cover, Weatherproof	

SECTION 2 - CONTROLS

FIGURE 2-6. CHARGER PLUG INSTALLATION - 110V PLUG

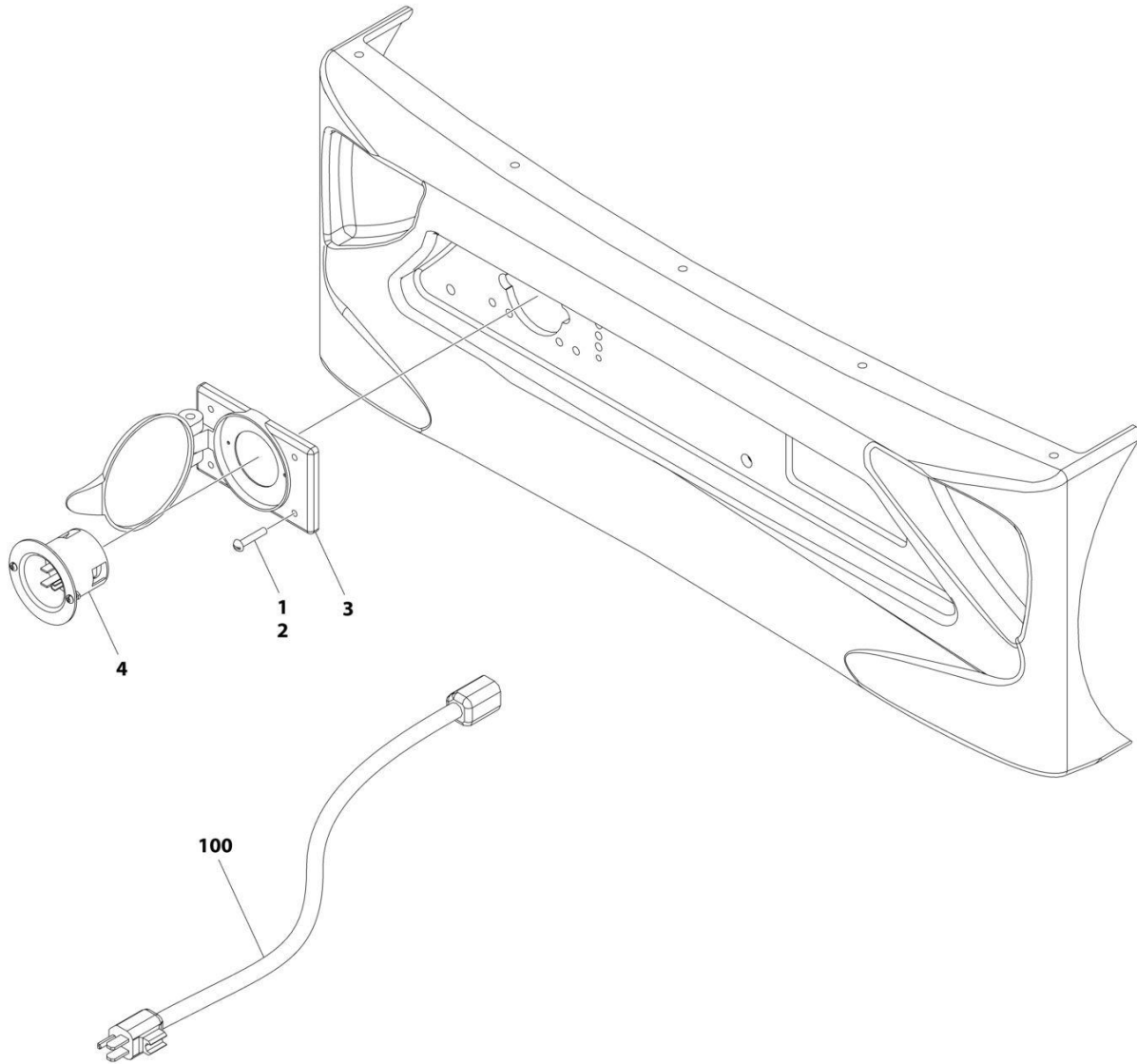

ART_1001097449

SECTION 2 - CONTROLS

FIGURE 2-6. CHARGER PLUG INSTALLATION - 110V PLUG

ITEM	PART NUMBER	QTY	DESCRIPTION	REV
	1001097449	Ref	CHARGER PLUG INSTALLATION - 110V PLUG	B
1	0100011	AR	Compound, Locking	
2	3911016	4	Screw #10 x 1	
3	4460802	1	Cover, Weatherproof	
4	4460803	1	Receptacle with Boot and Mounting Hardware	
100	4923174	6 ft/ 1.83m	CORD, EXTENSION (OPTIONAL)	

SECTION 2 - CONTROLS

FIGURE 2-7. CHARGER PLUG INSTALLATION - 110V IEC YELLOW PLUG (CE & UK CA SPECS)

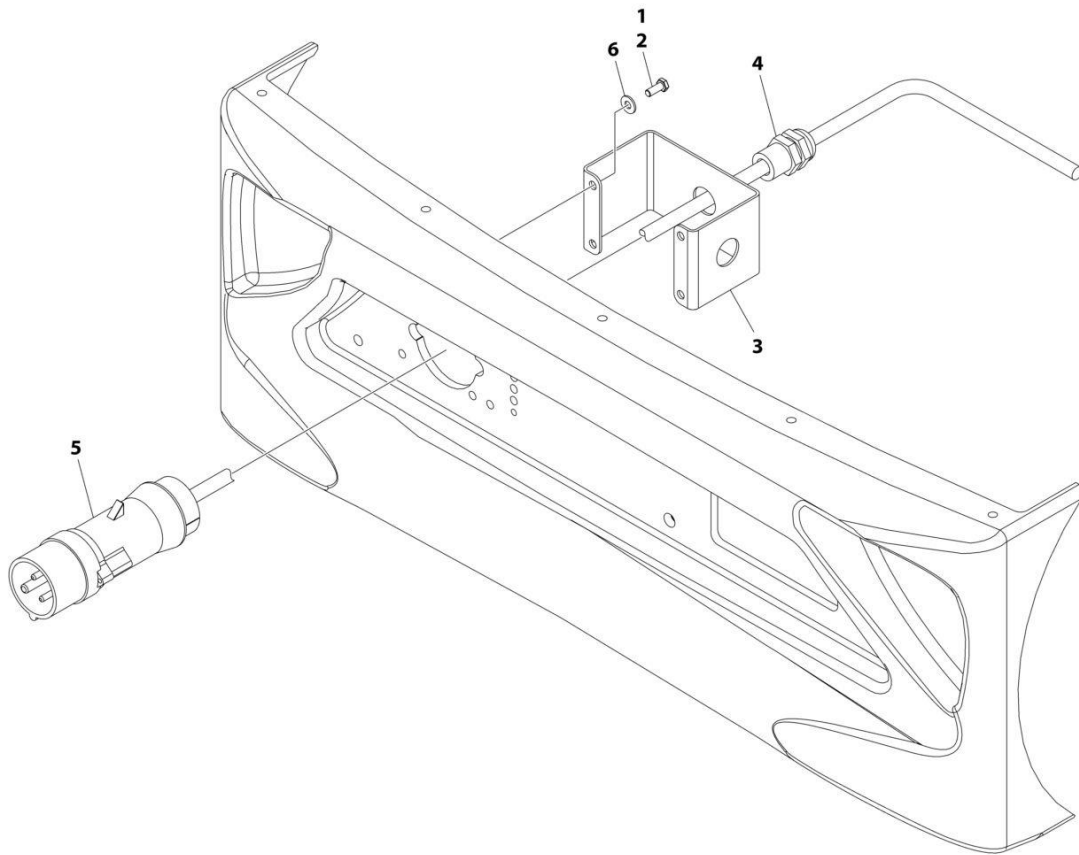

ART_1001097453

SECTION 2 - CONTROLS

FIGURE 2-7. CHARGER PLUG INSTALLATION - 110V IEC YELLOW PLUG (CE & UK CA SPECS)

ITEM	PART NUMBER	QTY	DESCRIPTION	REV
	1001097453	Ref	CHARGER PLUG INSTALLATION - 110V IEC YELLOW PLUG	B
1	0100011	AR	Compound, Locking	
2	0721004	4	Screw #10 x 1/2	
3	3571584	1	Plate	
4	4460428	1	Connector, Strain Relief	
5	4461196	1	Plug - 110V IEC Yellow	
6	4711000	4	Washer #10	

SECTION 2 - CONTROLS

FIGURE 2-8. CHARGER PLUG INSTALLATION - 220V IEC BLUE PLUG (CE & UK CA SPECS)

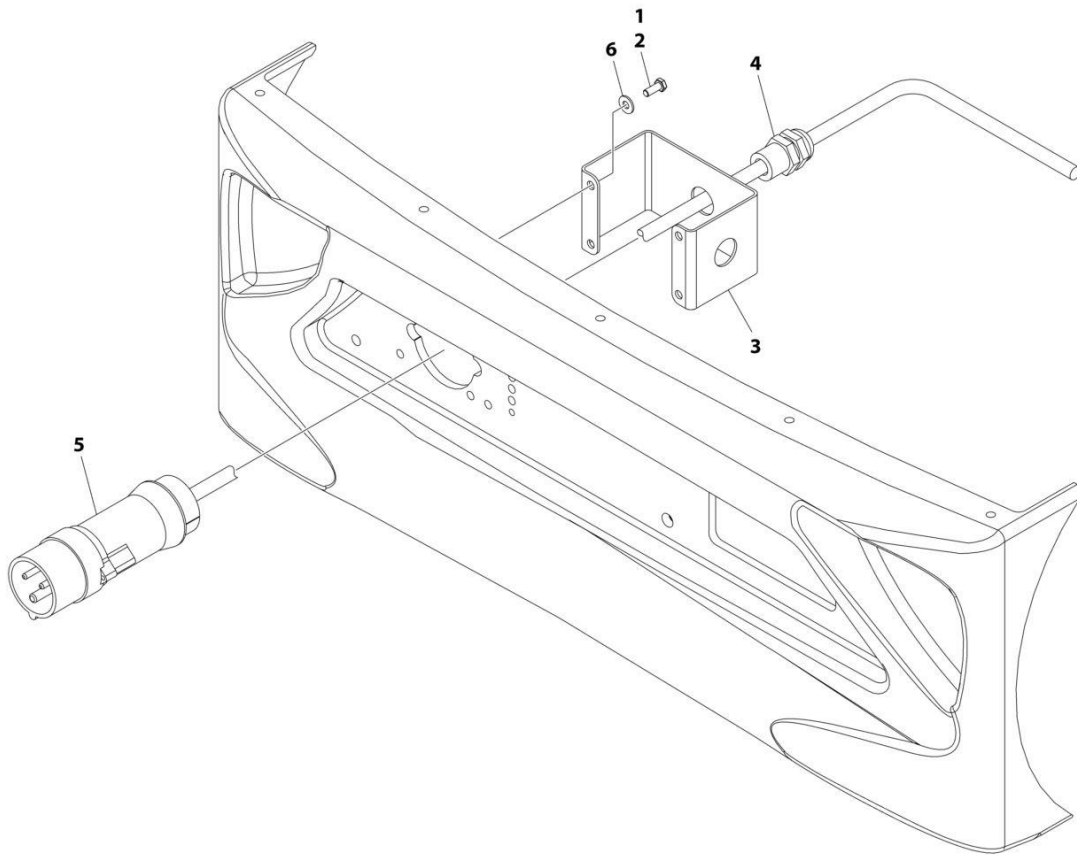

ART_1001097454

SECTION 2 - CONTROLS

FIGURE 2-8. CHARGER PLUG INSTALLATION - 220V IEC BLUE PLUG (CE & UK CA SPECS)

ITEM	PART NUMBER	QTY	DESCRIPTION	REV
	1001097454	Ref	CHARGER PLUG INSTALLATION - 220V IEC BLUE PLUG	B
1	0100011	AR	Compound, Locking	
2	0721004	4	Screw #10 x 1/2	
3	3571584	1	Plate	
4	4460428	1	Connector, Strain Relief	
5	4461199	1	Plug - 220V IEC Blue	
6	4711000	4	Washer #10	

SECTION 2 - CONTROLS

FIGURE 2-9. CHARGER PLUG INSTALLATION - 220V IEC KEYED GROUND PLUG (CE & UK CA SPECS)

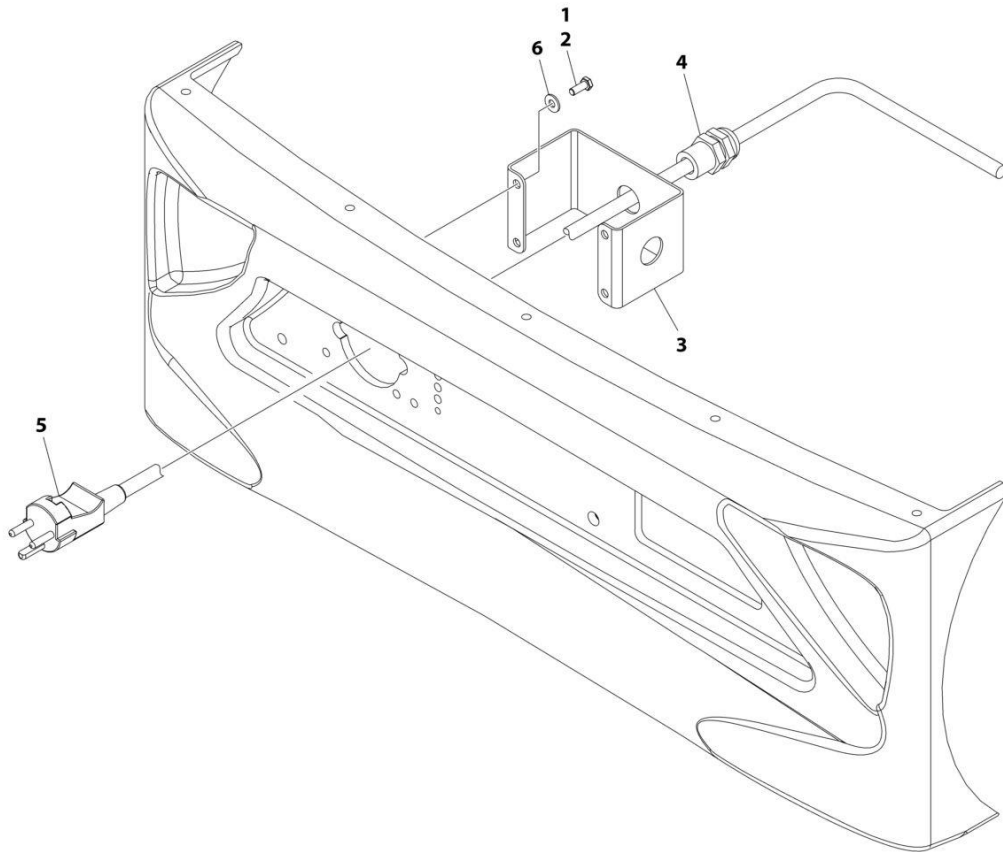

ART_1001097452

SECTION 2 - CONTROLS

FIGURE 2-9. CHARGER PLUG INSTALLATION - 220V IEC KEYED GROUND PLUG (CE & UK CA SPECS)

ITEM	PART NUMBER	QTY	DESCRIPTION	REV
	1001097452	Ref	CHARGER PLUG INSTALLATION - 220V IEC KEYED GROUND PLUG	B
1	0100011	AR	Compound, Locking	
2	0721004	4	Screw #10 x 1/2	
3	3571584	1	Plate	
4	4460428	1	Connector, Strain Relief	
5	4461249	1	Plug - 220V Keyed	
6	4711000	4	Washer #10	

SECTION 2 - CONTROLS

FIGURE 2-10. CHARGER PLUG INSTALLATION - 220V IEC POST GROUND PLUG (CE & UK CA SPECS)

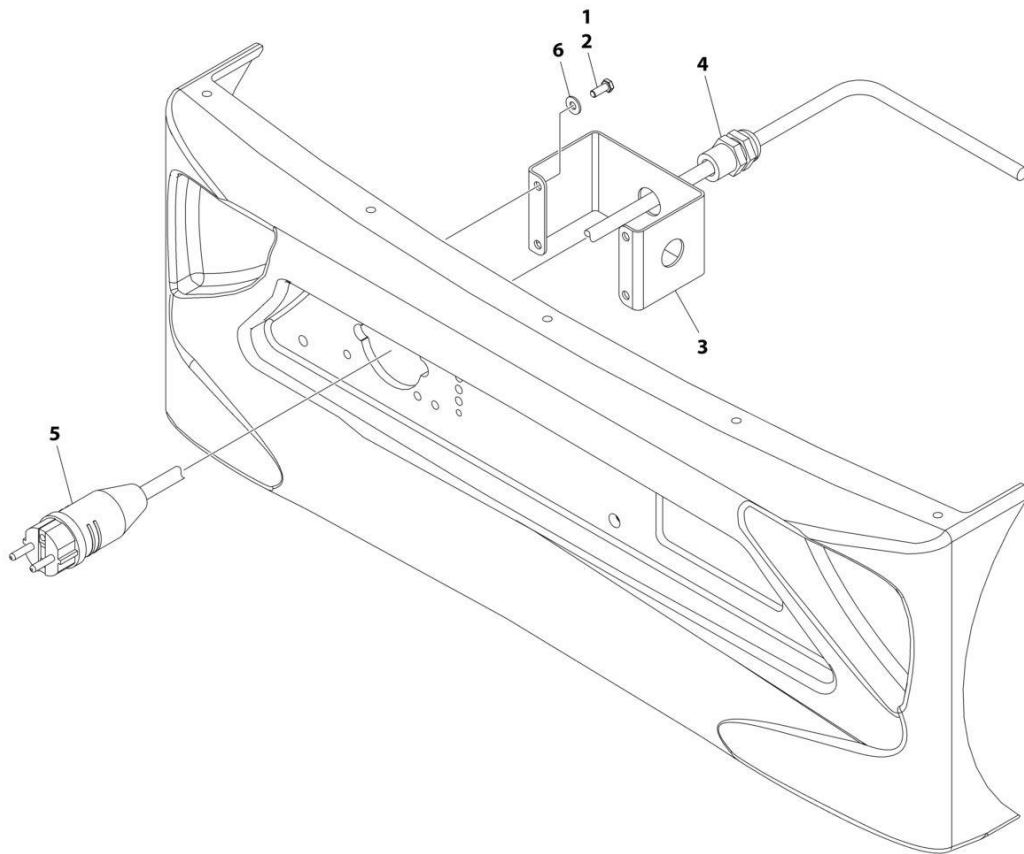

ART_1001097450

SECTION 2 - CONTROLS

FIGURE 2-10. CHARGER PLUG INSTALLATION - 220V IEC POST GROUND PLUG (CE & UK CA SPECS)

ITEM	PART NUMBER	QTY	DESCRIPTION	REV
	1001097450	Ref	CHARGER PLUG INSTALLATION - 220V IEC POST GROUND PLUG	C
1	0100011	AR	Compound, Locking	
2	0721004	4	Screw #10 x 1/2	
3	3571584	1	Plate	
4	4460428	1	Strain Relief, Connector	
5	4461205	1	Plug - 220V IEC Post Ground	
6	4711000	4	Washer #10	

SECTION 2 - CONTROLS

FIGURE 2-11. CHARGER PLUG INSTALLATION - 220V IEC SIDE GROUND PLUG (CE & UK CA SPECS)

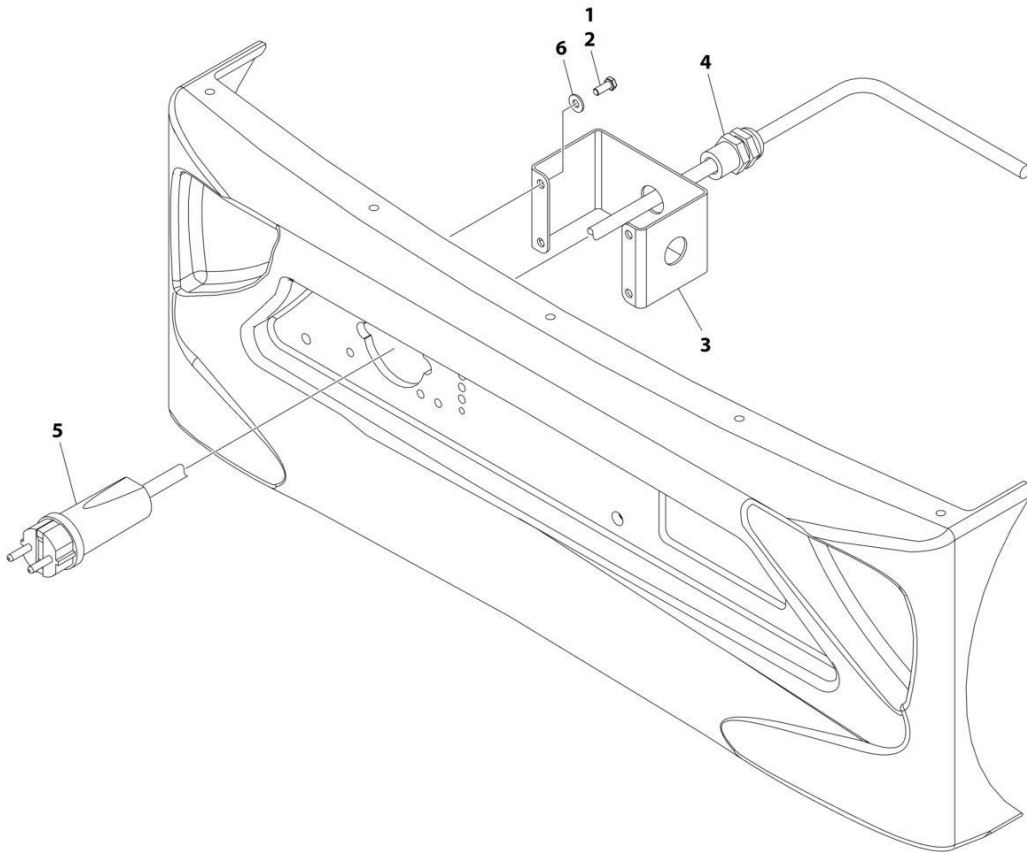

ART_1001097451

SECTION 2 - CONTROLS

FIGURE 2-11. CHARGER PLUG INSTALLATION - 220V IEC SIDE GROUND PLUG (CE & UK CA SPECS)

ITEM	PART NUMBER	QTY	DESCRIPTION	REV
	1001097451	Ref	CHARGER PLUG INSTALLATION - 220V IEC SIDE GROUND PLUG	B
1	0100011	AR	Compound, Locking	
2	0721004	4	Screw #10 x 1/2	
3	3571584	1	Plate	
4	4460428	1	Connector, Strain Relief	
5	4461205	1	Plug - 220V Side Ground	
6	4711000	4	Washer #10	

SECTION 2 - CONTROLS

FIGURE 2-12. CHARGER PLUG INSTALLATION - 220V (AUSTRALIAN SPECS)

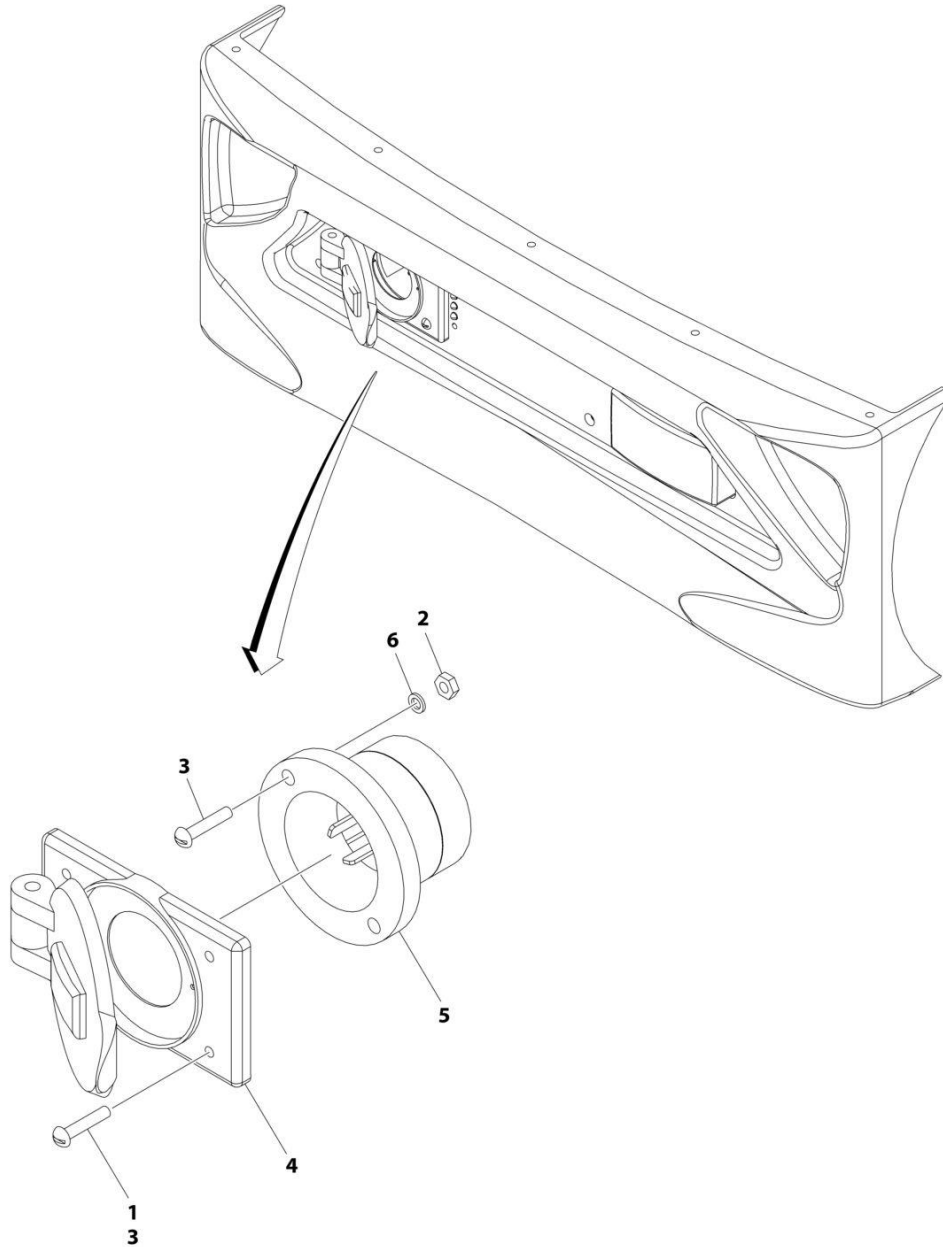

ART_1001097455

SECTION 2 - CONTROLS

FIGURE 2-12. CHARGER PLUG INSTALLATION - 220V (AUSTRALIAN SPECS)

ITEM	PART NUMBER	QTY	DESCRIPTION	REV
	1001097455	Ref	CHARGER PLUG INSTALLATION - 220V	C
1	0100011	AR	Compound, Locking	
2	3311001	1	Nut #10	
3	3911016	6	Screw #24 x 1	
4	4460802	1	Cover, Weatherproof	
5	4460940	1	Plug	
6	4761000	2	Washer #10	

SECTION 2 - CONTROLS

FIGURE 2-13. GROUND CONTROL AND TRACTION MODULE INSTALLATION (ALL SPECS EXCEPT JAPANESE SPECS)

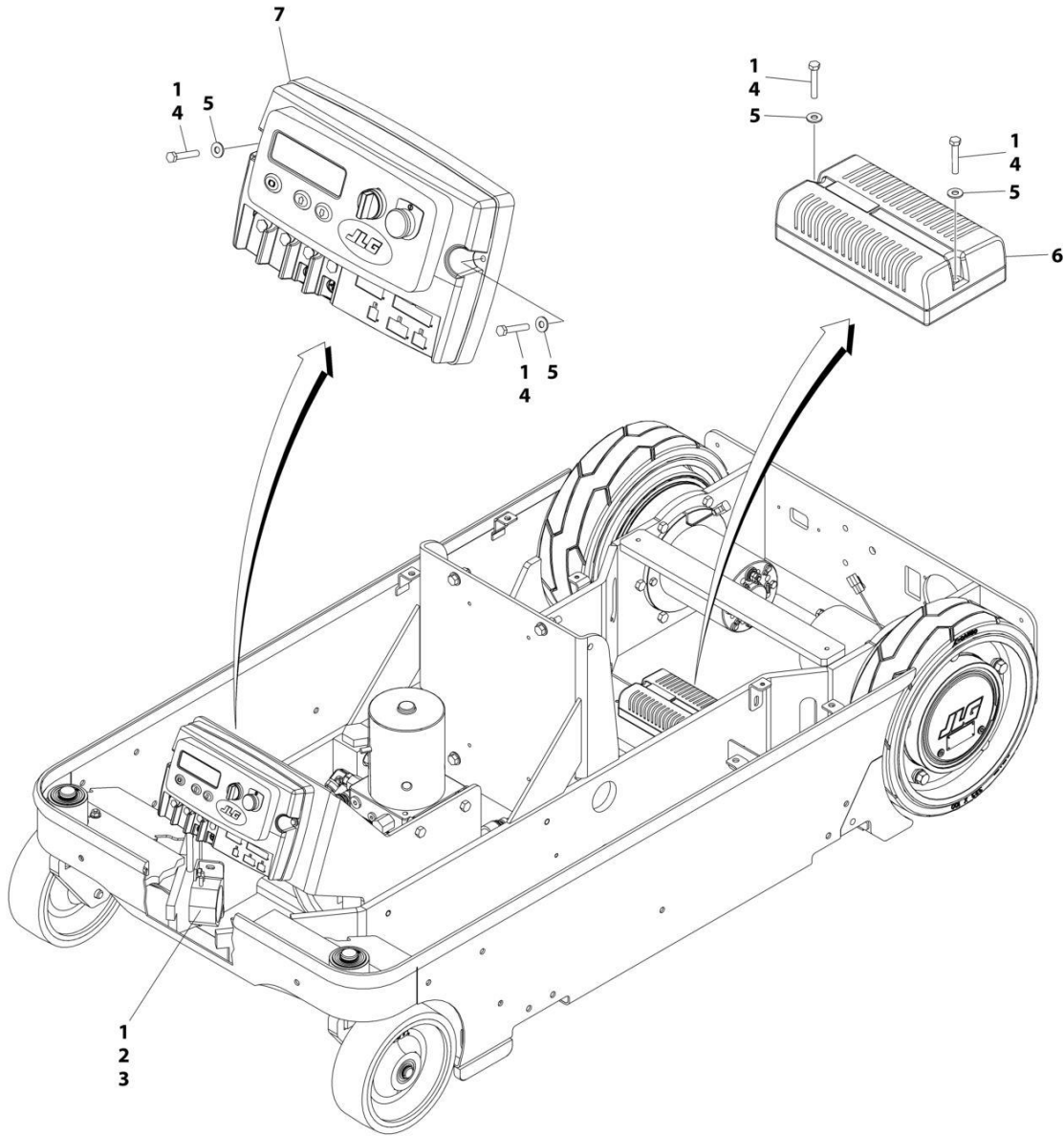

ART_1001255261

SECTION 2 - CONTROLS

FIGURE 2-13. GROUND CONTROL AND TRACTION MODULE INSTALLATION (ALL SPECS EXCEPT JAPANESE SPECS)

ITEM	PART NUMBER	QTY	DESCRIPTION	REV
	1001255261	Ref	GROUND CONTROL AND TRACTION MODULE INSTALLATION	A
1	0100011	AR	Compound, Locking	
2	0140033	1	Alarm	
3	0641404	2	Bolt 1/4 x 1/2	
4	0721010	4	Bolt #10 X 1-1/4	
5	4751000	4	Washer #10	
6	1001231450	1	Module, Traction	
7	1001255259	1	Ground Control Station/Module Assembly	

SECTION 2 - CONTROLS

FIGURE 2-14. GROUND CONTROL AND TRACTION MODULE INSTALLATION (CHINESE AND JAPANESE SPECS)

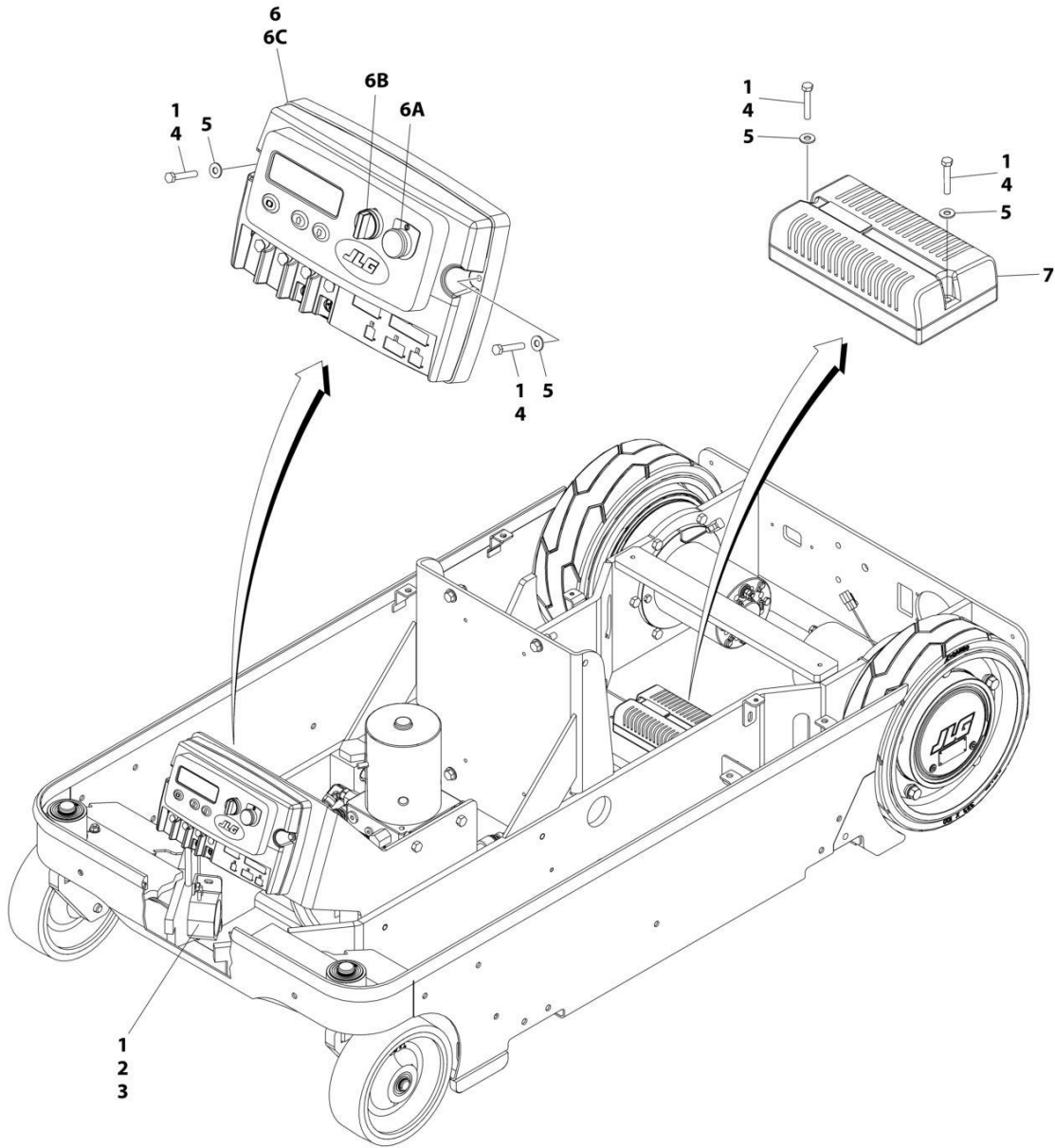

ART_1001255262

SECTION 2 - CONTROLS

FIGURE 2-14. GROUND CONTROL AND TRACTION MODULE INSTALLATION (CHINESE AND JAPANESE SPECS)

ITEM	PART NUMBER	QTY	DESCRIPTION	REV
	1001255262	Ref	GROUND CONTROL AND TRACTION MODULE INSTALLATION	A
1	0100011	AR	Compound, Locking	
2	0140033	1	Alarm	
3	0641404	2	Bolt 1/4 x 1/2	
4	0721010	4	Bolt #10 x 1-1/4	
5	4751000	4	Washer #10	
6	1001255260	1	Ground Control Station/Module Assembly	
7	1001231450	1	Module, Traction	

SECTION 2 - CONTROLS

FIGURE 2-15. PLATFORM CONTROL BOX ASSEMBLY

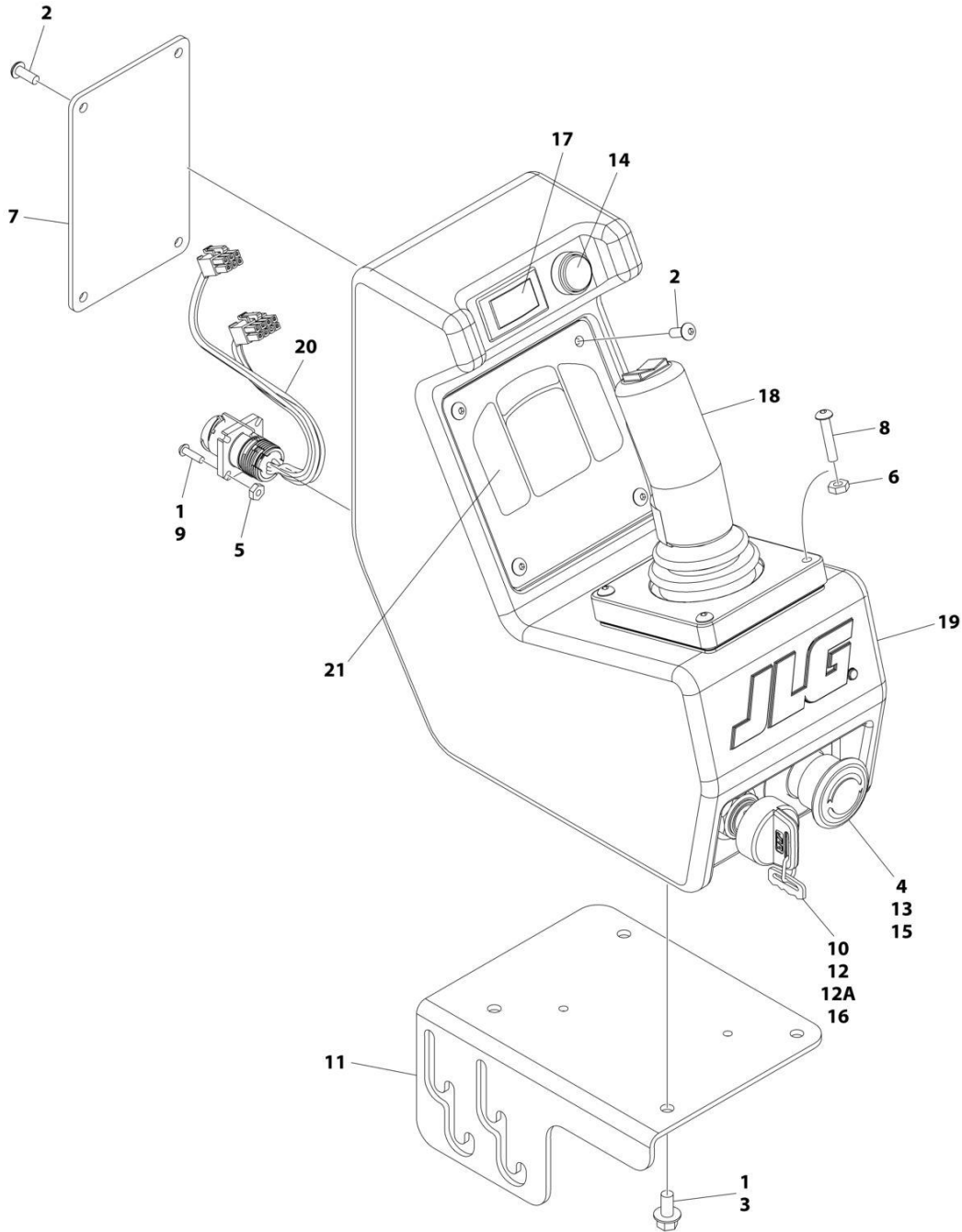

ART_1001228495

SECTION 2 - CONTROLS

FIGURE 2-15. PLATFORM CONTROL BOX ASSEMBLY

ITEM	PART NUMBER	QTY	DESCRIPTION	REV
	1001228495	Ref	PLATFORM CONTROL BOX ASSEMBLY	D
1	0100011	AR	Compound, Locking	
2	0630464	8	Screw #10 x 1/2	
3	0791404	4	Screw 1/4 x 1/2	
4	1706007	1	Decal - Emergency Stop	
5	3310601	4	Nut #6	
6	3311005	4	Nut #10	
7	3380540	1	Panel, Control Box	
8	3900189	4	Screw #10 x 1	
9	3910608	4	Screw #6 x 1/2	
10	3910804	2	Screw #8 x 1/4	
11	4340884	1	Mount, Control Box	
12	4360467	1	Switch, Key	
12A	2860030	1	Key, Replacement	
13	4360562	1	Switch, Emergency Stop	
14	4360567	1	Switch, Horn	
15	4923107	1	Emergency Stop Harness	
16	4923108	1	Key Switch Harness	
17	1001228835	1	Plug	
18	1001098192	1	Controller Assembly (See Separate Breakdown in this Section)	
19	1001098193	1	Box, Control	
20	1001227884	1	Power Harness (See Separate Breakdown in ELECTRICAL Section)	
21	1001228458	1	Module, Controller	

SECTION 2 - CONTROLS

FIGURE 2-16. CONTROLLER ASSEMBLY

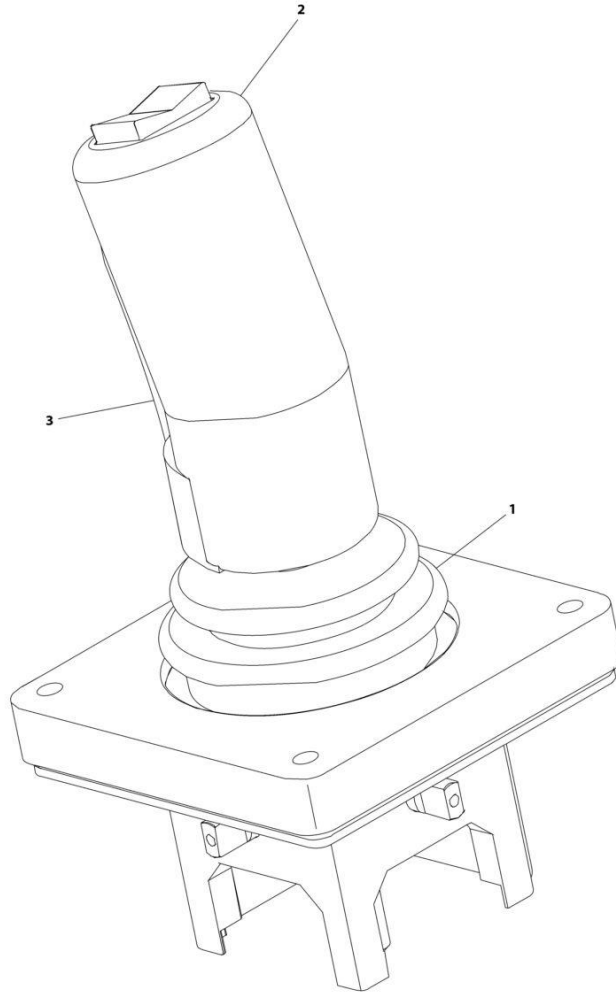

ART_1001098192

SECTION 2 - CONTROLS

FIGURE 2-16. CONTROLLER ASSEMBLY

ITEM	PART NUMBER	QTY	DESCRIPTION	REV
	1001098192	Ref	CONTROLLER ASSEMBLY	A
1	70001250	1	Boot, Rubber (Base of Controller)	
1	7027766	1	Ring, Retaining	
1	70001251	1	Bezel, Mounting	
1	70001252	1	Gasket, Mounting	
2	70000084	1	Boot, Rubber (Steer Switch)	
2	70000082	2	Microswitch	
2	7027365	1	Actuator, Handle	
2	70000684	2	Screw	
2	70000686	2	Screw	
2	70000683	4	Washer, Neoprene	
2	70000685	2	Spacer	
2	70001253	1	Gasket, Handle	
3	7027765	1	Lever, Enable	
3	7027367	1	Switch, Push Button (Note: Not Shown - Located Behind Lever)	

SECTION 3 - MAST

SECTION 3 - MAST

FIGURE 3-1. MAST INSTALLATION

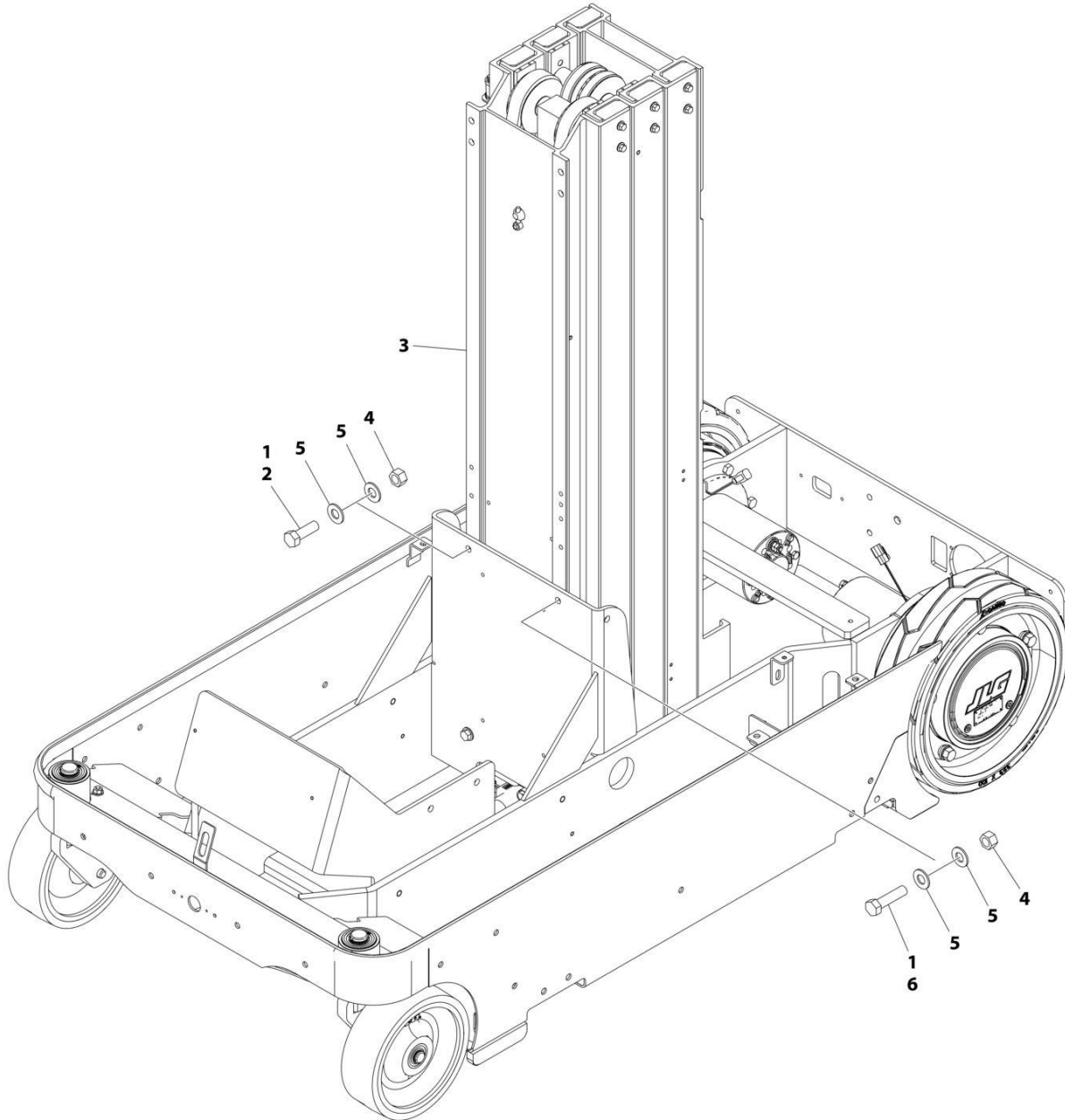

ART_0273545

FIGURE 3-1. MAST INSTALLATION

ITEM	PART NUMBER	QTY	DESCRIPTION	REV
	0273545	Ref	MAST INSTALLATION	B
1	0100019	AR	Compound, Locking	
2	0641609	3	Bolt 3/8 x 1-1/8	
3	0801394	1	Mast Assembly (See Separate Breakdown in this Section)	
4	3311601	4	Nut 3/8	
5	4711600	8	Washer 3/8	
6	0641612	1	Bolt 3/8 x 1-1/2	

SECTION 3 - MAST

FIGURE 3-2. MAST ASSEMBLY

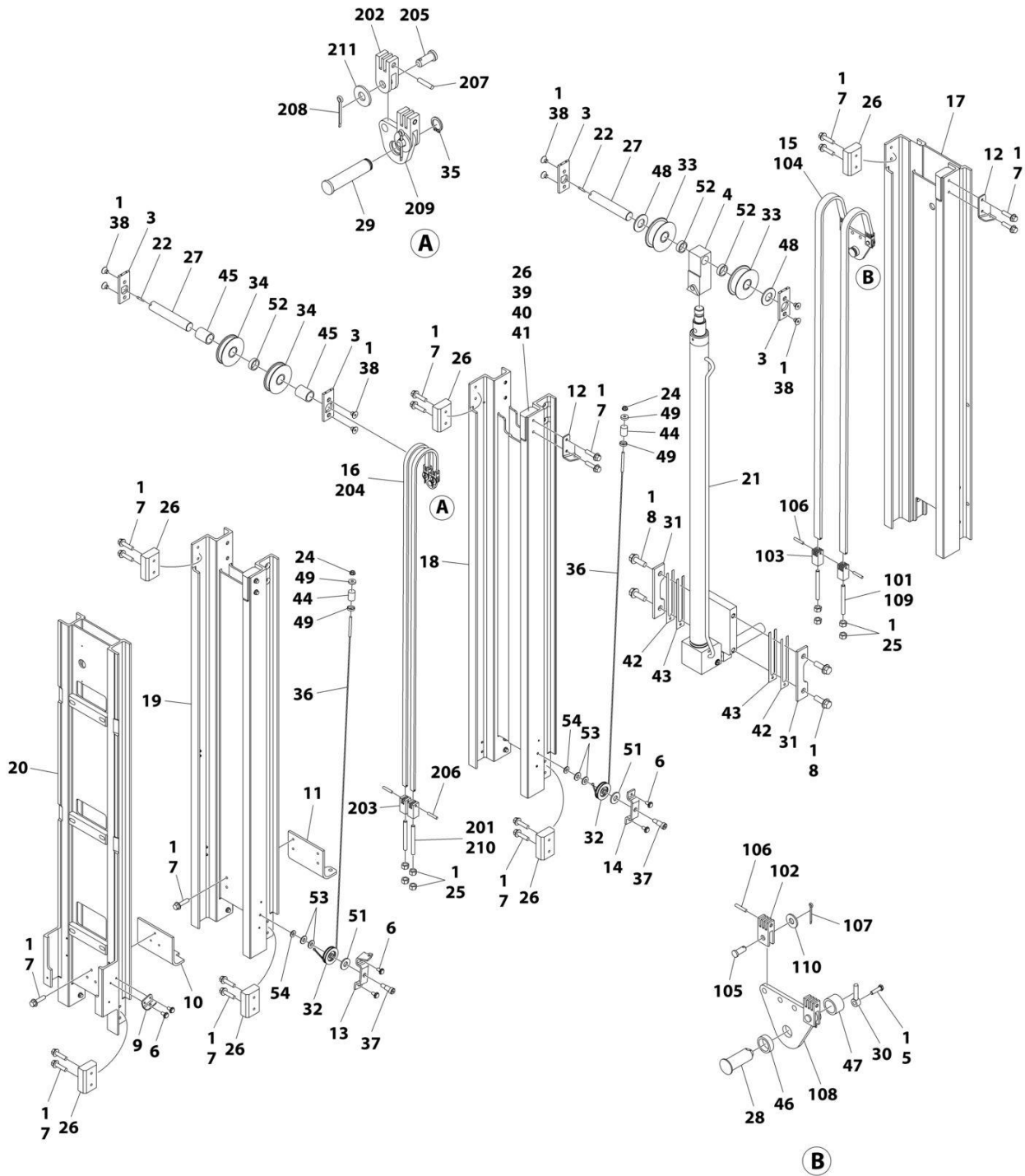

ART_0801394

SECTION 3 - MAST

FIGURE 3-2. MAST ASSEMBLY

ITEM	PART NUMBER	QTY	DESCRIPTION	REV
	0801394	Ref	MAST ASSEMBLY	F
1	0100011	AR	Compound, Locking	
3	0362735	4	Bar, Support	
4	0561341	1	Block, Anchor	
5	0721006	1	Screw #10 x 3/4	
6	0791003	6	Screw #10 x 3/8	
7	0811408	31	Screw 1/4 x 1	
8	0791812	4	Screw 1/2 x 1-1/2	
9	0902047	1	Bracket, Sequence Cable	
10	0902423	1	Bracket, Chain Attach	
11	0902424	1	Bracket, Chain Attach	
12	0902431	2	Bracket, Sequence Cable	
13	0902445	1	Bracket, Sequence Cable	
14	0902698	1	Bracket, Sequence Cable	
15	1260375	1	Chain Assembly - #446 (See Items 101-110 for Breakdown)	
16	1260376	1	Chain Assembly - #444 (See Items 201-211 for Breakdown)	
17	1271567	1	Channel, Mast #1	
18	1271568	1	Channel, Mast #2	
19	1271569	1	Channel, Mast #3	
20	1271577	1	Channel, Header	
21	1001225209	1	Lift Cylinder Assembly (See Separate Breakdown in CYLINDER SECTION)	
22	2880310	2	Key	
23	3020041	AR	Lubricant (Not Shown - Used on Slides)	
24	3311408	2	Nut 1/4	
25	3311601	8	Nut 3/8	
26	3340845	12	Pad	
27	3422717	2	Pin	
28	3422750	1	Pin	
29	3422752	1	Pin	
30	3422757	1	Pin, Keeper	
31	3570893	2	Plate, Cylinder Mounting	
32	3580269	2	Sheave, Sequence Cable	
33	3580286	2	Sheave Assembly	
33	0440246	2	Bearing (1 Per Assembly)	
34	3580293	2	Sheave Assembly	
34	0440249	2	Bearing (1 Per Assembly)	
35	3760383	1	Ring, Retaining	
36	3890039	2	Cable, Sequence	
37	3900187	2	Screw, Shoulder	
38	3900192	8	Screw 3/8 x 1/2	
39	4070860	AR	Shim, Slide Pad	
40	4070861	AR	Shim, Slide Pad	
41	4070862	AR	Shim, Slide Pad	
42	4070970	AR	Shim, Cylinder Mount	
43	4070971	AR	Shim, Cylinder Mount	
44	4160124	2	Spring	
45	4567491	1	Tube, Spacer	
46	4567750	1	Tube, Spacer	
47	4567751	1	Tube, Spacer	

SECTION 3 - MAST

ITEM	PART NUMBER	QTY	DESCRIPTION	REV
48	4740007	2	Washer	
49	4740414	4	Washer, Cup	
51	4711500	2	Washer 5/16	
52	4569003	3	Tube, Spacer	
53	4711400	4	Washer 1/4	
54	4761400	2	Washer, Lock 1/4	
60	0273417	Ref	Mast Kit (Includes Items 17-20) (Not Shown)	H
	1260375	Ref	CHAIN ASSEMBLY - #446 CHAIN	B
101	0100062	AR	Compound, Locking	
102	0561153	2	Block, Chain Anchor	
103	0561409	2	Block, Chain Anchor	
104	See Note	NLA	Chain (Note: Use p/n 1260375)	
105	3422338	2	Pin	
106	3422346	4	Pin	
107	3450304	2	Pin, Cotter	
108	3571101	1	Plate, Chain Adjustment	
109	4300111	2	Stud	
110	4751500	2	Washer 5/16	
	1260376	Ref	CHAIN ASSEMBLY - #444 CHAIN	C
201	0100019	AR	Compound, Locking	
202	0561149	2	Block, Chain Anchor	
203	0561408	2	Block, Chain Anchor	
204	See Note	NLA	Chain (Note: Use p/n 1260376)	
205	3422338	2	Pin	
206	3422346	2	Pin	
207	3422355	2	Pin	
208	3450304	2	Pin, Cotter	
209	3571103	1	Plate, Chain Adjustment	
210	4300111	2	Stud	
211	4751500	2	Washer 5/16	

SECTION 4 - PLATFORM

SECTION 4 - PLATFORM

FIGURE 4-1. PLATFORM INSTALLATION - WITHOUT GATE LATCH

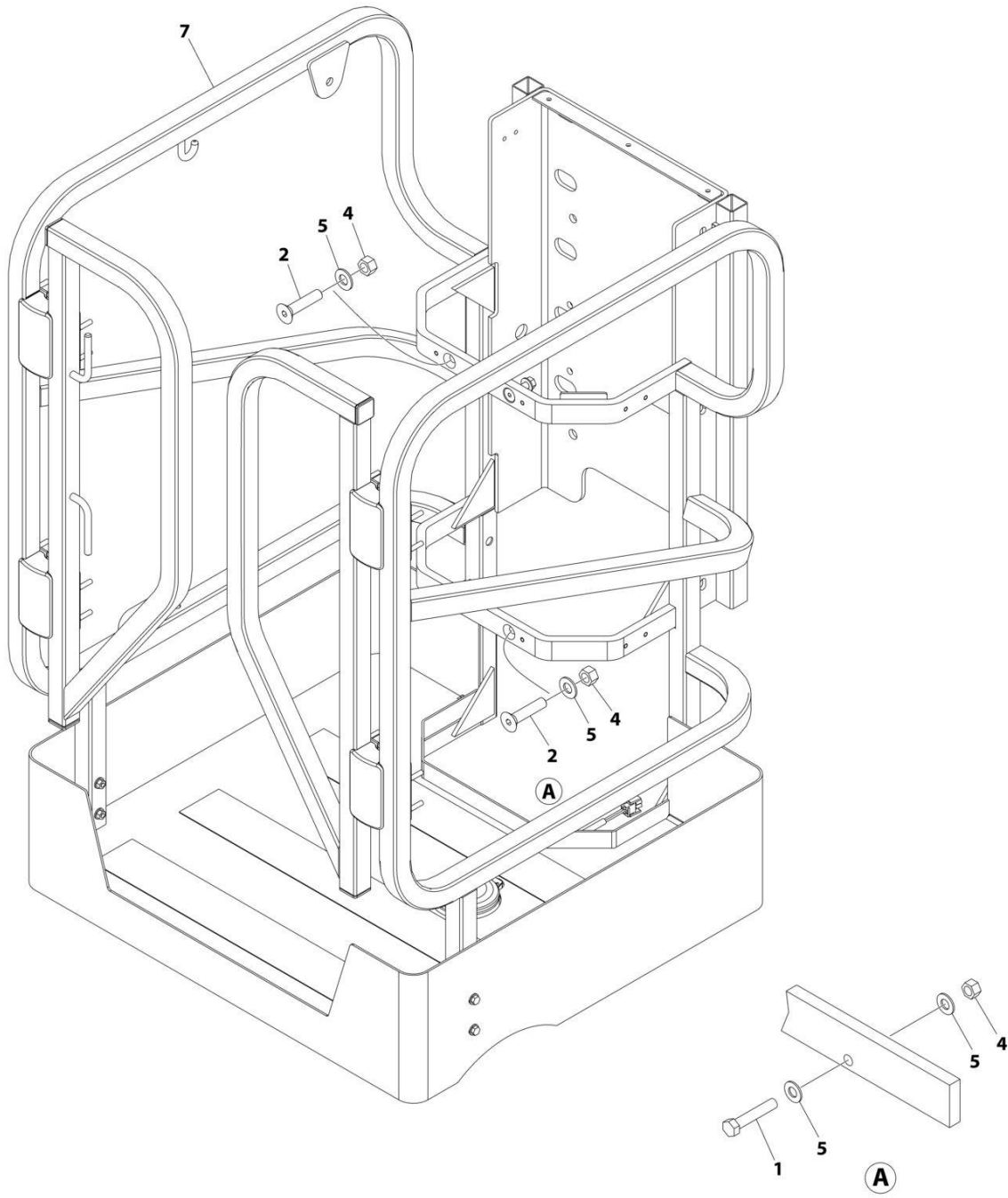

ART_1001254425

SECTION 4 - PLATFORM

FIGURE 4-1. PLATFORM INSTALLATION - WITHOUT GATE LATCH

ITEM	PART NUMBER	QTY	DESCRIPTION	REV
	1001254425	Ref	PLATFORM INSTALLATION	B
1	0641616	2	Bolt 3/8 x 2	
2	0741614	4	Screw 3/8 x 1-3/4	
4	3311605	6	Nut 3/8	
5	4711600	8	Washer 3/8	
7	1001254426	1	Platform Assembly (See Separate Breakdown in this Section)	

SECTION 4 - PLATFORM

FIGURE 4-2. PLATFORM ASSEMBLY - WITHOUT GATE LATCH

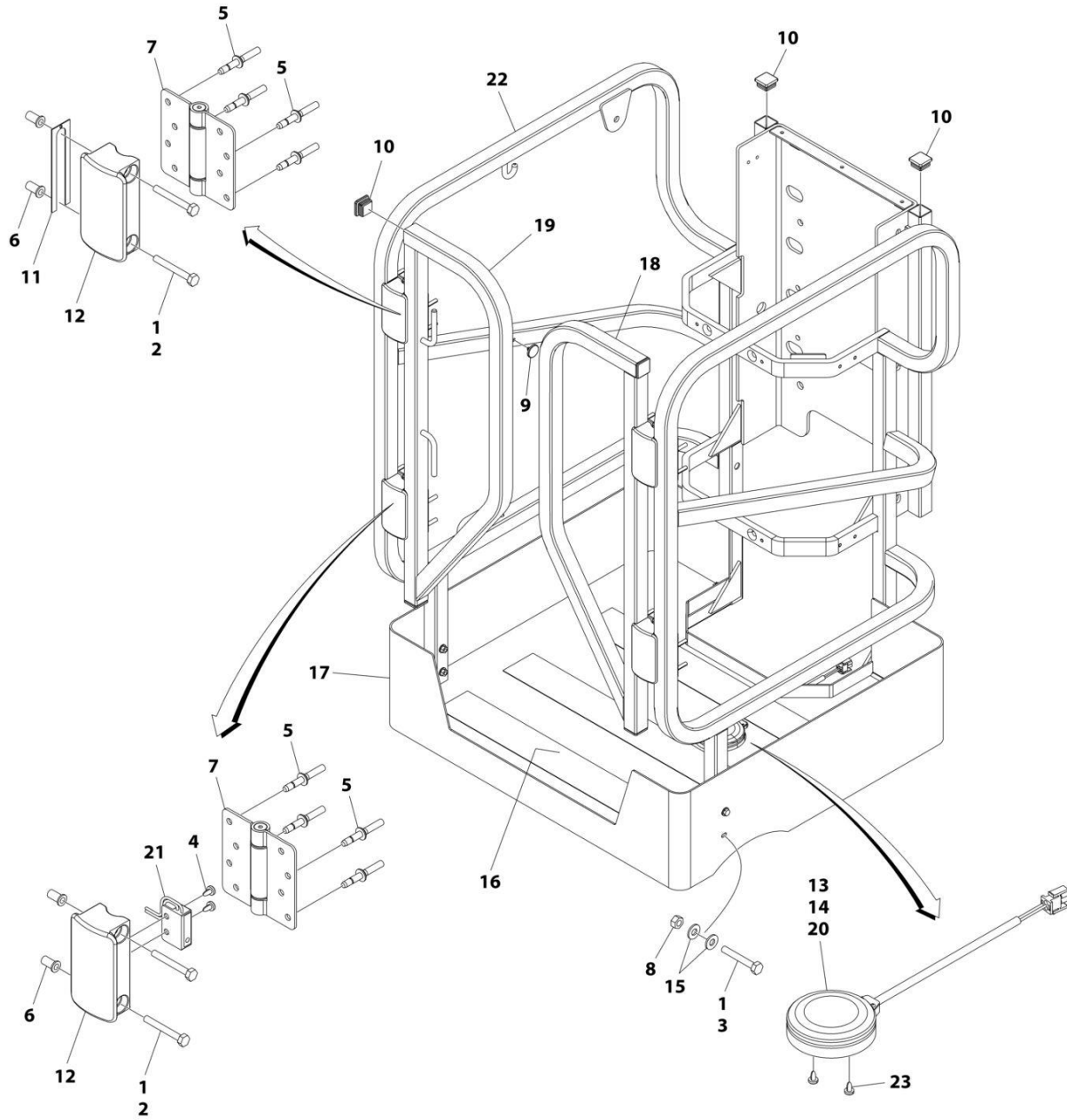

ART_1001254426

SECTION 4 - PLATFORM

FIGURE 4-2. PLATFORM ASSEMBLY - WITHOUT GATE LATCH

ITEM	PART NUMBER	QTY	DESCRIPTION	REV
	1001254426	Ref	PLATFORM ASSEMBLY	C
1	0100011	AR	Compound, Locking	
2	0641416	8	Bolt 1/4 x 2	
3	0681414	4	Bolt 1/4 x 1-3/4	
4	0751003	4	Screw	
5	2080040	16	Fastener	
6	2080043	8	Rivnut 1/4	
7	2600294	4	Hinge	
8	3311405	4	Nut 1/4	
9	3340962	2	Pad	
10	3520072	6	Plug	
11	4071095	AR	Shim 20Ga	
12	4220309	4	Stop, Gate	
13	4460035	1	Terminal	
14	4460320	1	Plug, Male - 2 Position	
15	4711400	8	Washer 1/4	
16	1001099638	3	Tape, Safety	
17	1001255194	1	Base	
18	1001228875	1	Gate (RH)	
19	1001228876	1	Gate (LH)	
20	1001229726	1	Footswitch	
21	1001230161	2	Switch, Proximity	
22	1001272917	1	Rail	
23	0751003	2	Screw #10 x 3/8	
23	3900205	2	Screw #10 x 5/8	

SECTION 4 - PLATFORM

FIGURE 4-3. PLATFORM INSTALLATION - WITH GATE LATCH

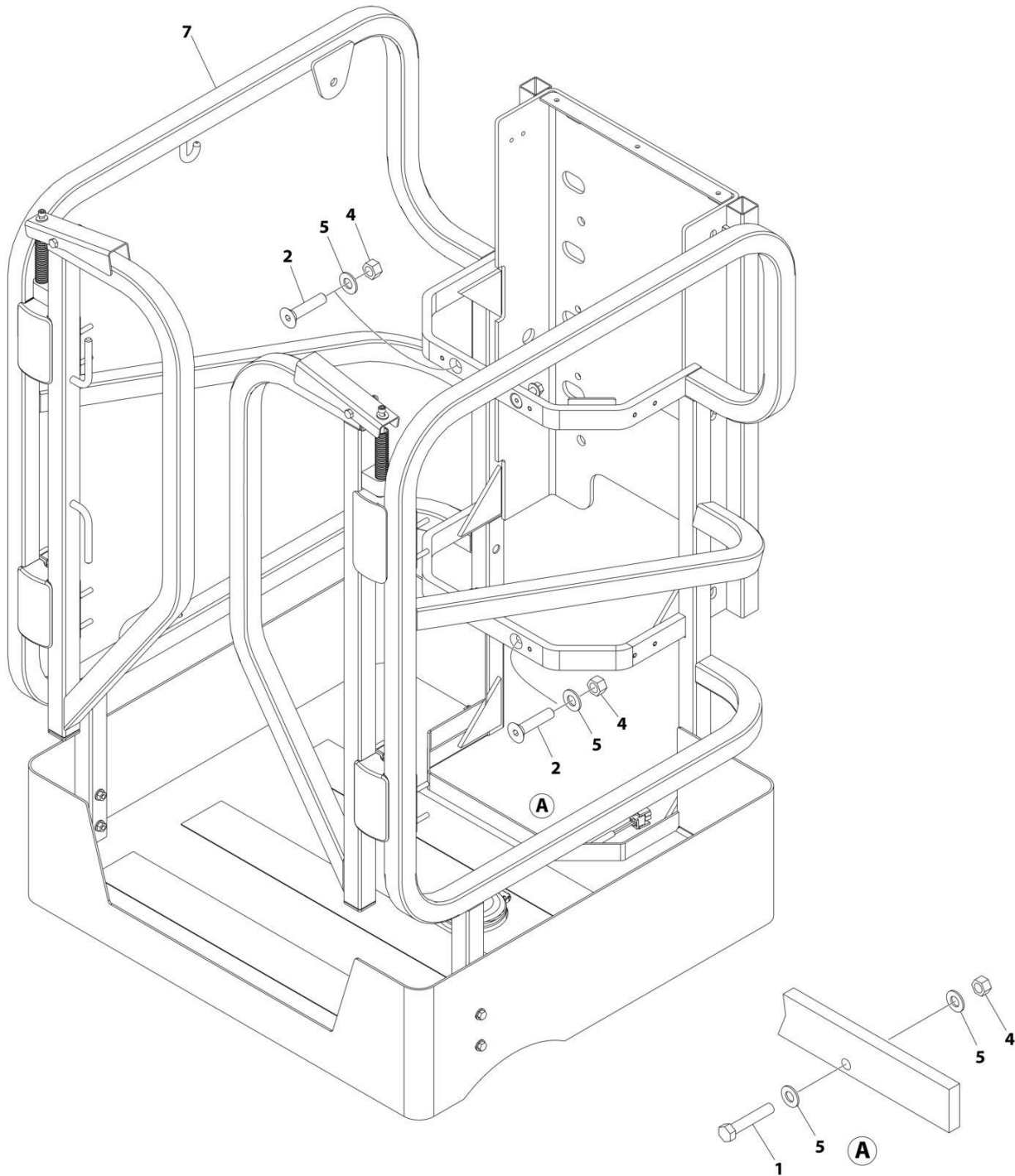

ART_1001254427

SECTION 4 - PLATFORM

FIGURE 4-3. PLATFORM INSTALLATION - WITH GATE LATCH

ITEM	PART NUMBER	QTY	DESCRIPTION	REV
	1001254427	Ref	PLATFORM INSTALLATION	B
1	0641616	2	Bolt 3/8 x 2	
2	0741614	4	Screw 3/8 x 1-3/4	
4	3311605	6	Nut 3/8	
5	4711600	8	Washer 3/8	
7	1001254428	1	Platform Assembly (See Separate Breakdown in this Section)	

SECTION 4 - PLATFORM

FIGURE 4-4. PLATFORM ASSEMBLY - WITH GATE LATCH

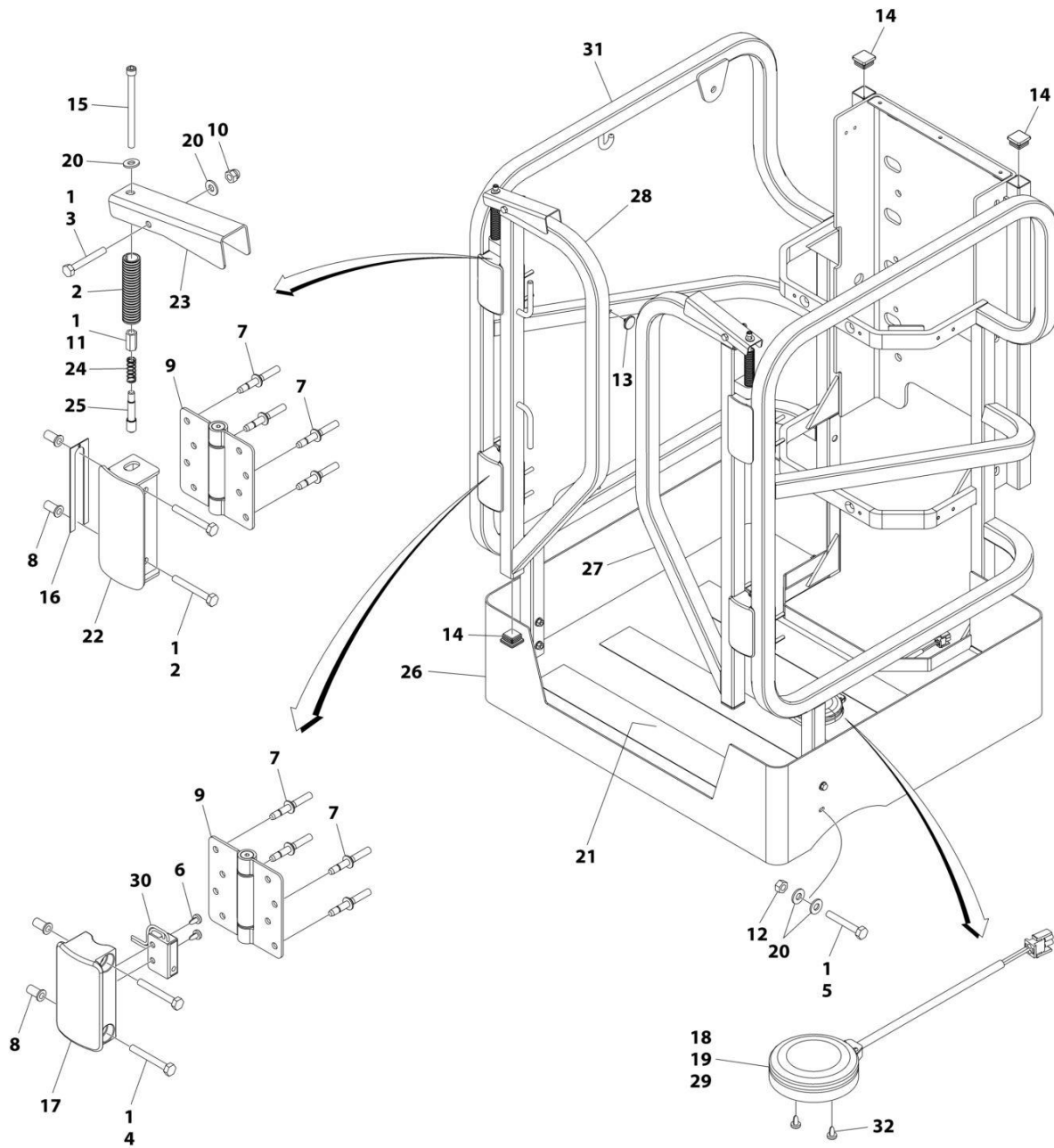

ART_1001254428

SECTION 4 - PLATFORM

FIGURE 4-4. PLATFORM ASSEMBLY - WITH GATE LATCH

ITEM	PART NUMBER	QTY	DESCRIPTION	REV
	1001254428	Ref	PLATFORM ASSEMBLY	C
1	0100011	AR	Compound, Locking	
2	280013	6 in/16cm	Conduit	
3	0641415	2	Bolt 1/4 x 1-7/8	
4	0641416	8	Bolt 1/4 x 2	
5	0681414	4	Bolt 1/4 x 1-3/4	
6	0751003	4	Screw	
7	2080040	16	Fastener	
8	2080043	8	Rivnut 1/4	
9	2600294	4	Hinge	
10	3300151	2	Nut 1/4	
11	3300381	2	Nut	
12	3311405	4	Nut 1/4	
13	3340962	2	Pad	
14	3520072	6	Plug	
15	3931456	2	Capscrew 1/4 x 3-1/2	
16	4071095	AR	Shim 20Ga	
17	4220309	2	Stop, Gate	
18	4460035	1	Terminal	
19	4460320	1	Plug, Male - 2 Position	
20	4711400	12	Washer 1/4	
21	1001099638	3	Tape, Safety	
22	1001100141	2	Stop, Gate	
23	1001100142	2	Handle	
24	1001100634	2	Spring	
25	1001101529	2	Pin, Plunger	
26	1001255194	1	Base	
27	1001228873	1	Gate (RH)	
28	1001228874	1	Gate (LH)	
29	1001229726	1	Footswitch	
30	1001230161	2	Switch, Proximity	
31	1001272917	1	Rail	
32	0751003	2	Screw #10 x 3/8	
32	3900205	2	Screw #10 x 3/8	

SECTION 4 - PLATFORM

FIGURE 4-5. TRAY INSTALLATION - MANUAL

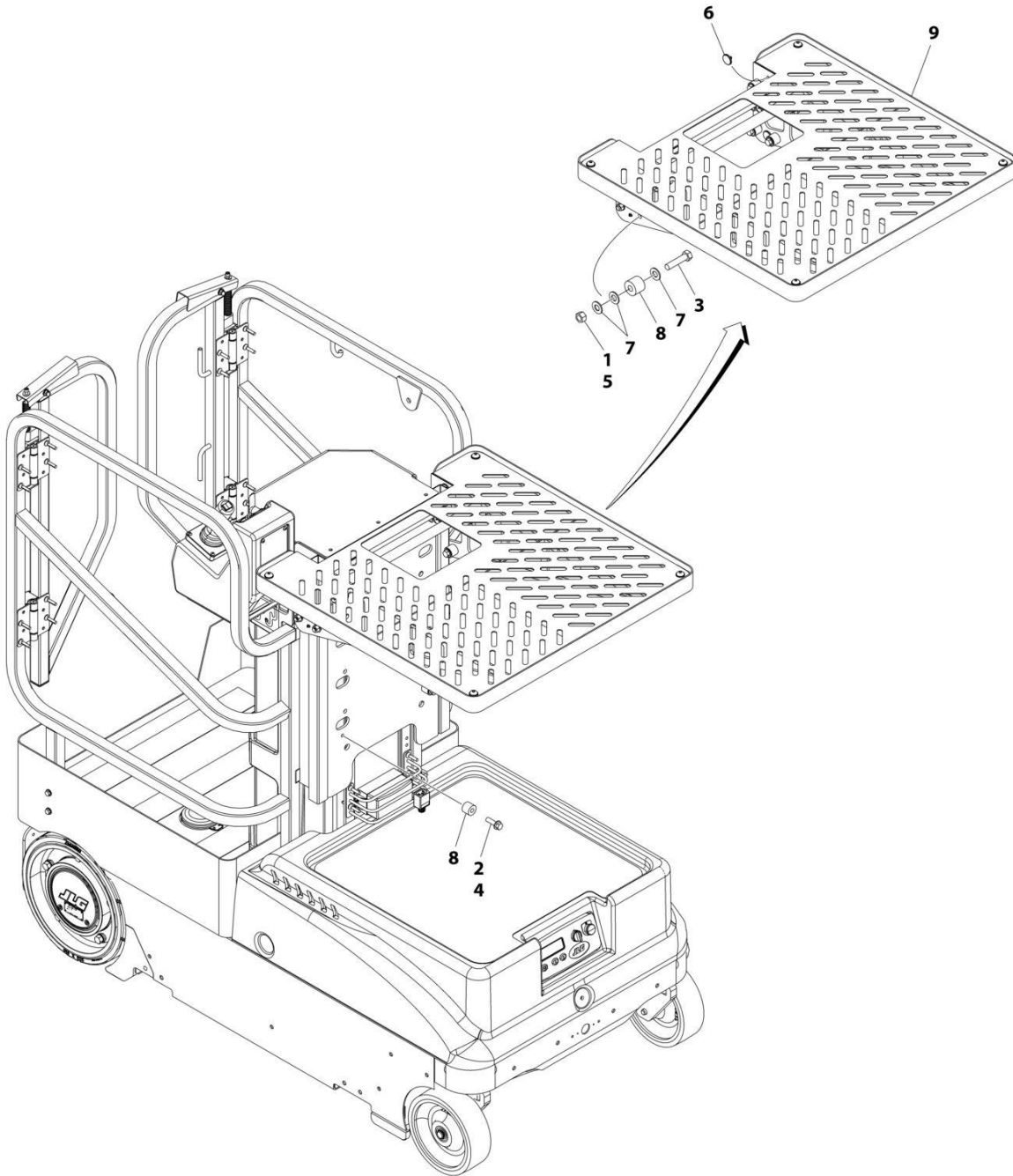

ART_1001228847

SECTION 4 - PLATFORM

FIGURE 4-5. TRAY INSTALLATION - MANUAL

ITEM	PART NUMBER	QTY	DESCRIPTION	REV
	1001228847	Ref	TRAY INSTALLATION	A
1	0100011	AR	Compound, Locking	
2	0100019	AR	Compound, Locking	
3	0641613	6	Bolt 3/8 x 1-5/8	
4	0811610	2	Screw 3/8 x 1-1/4	
5	3271601	6	Nut 3/8	
6	3340962	4	Pad	
7	4711600	18	Washer 3/8	
8	1001181407	8	Bar, Spacer	
9	1001228854	1	Tray Assembly (See Separate Breakdown in this Section)	

SECTION 4 - PLATFORM

FIGURE 4-6. TRAY ASSEMBLY - MANUAL

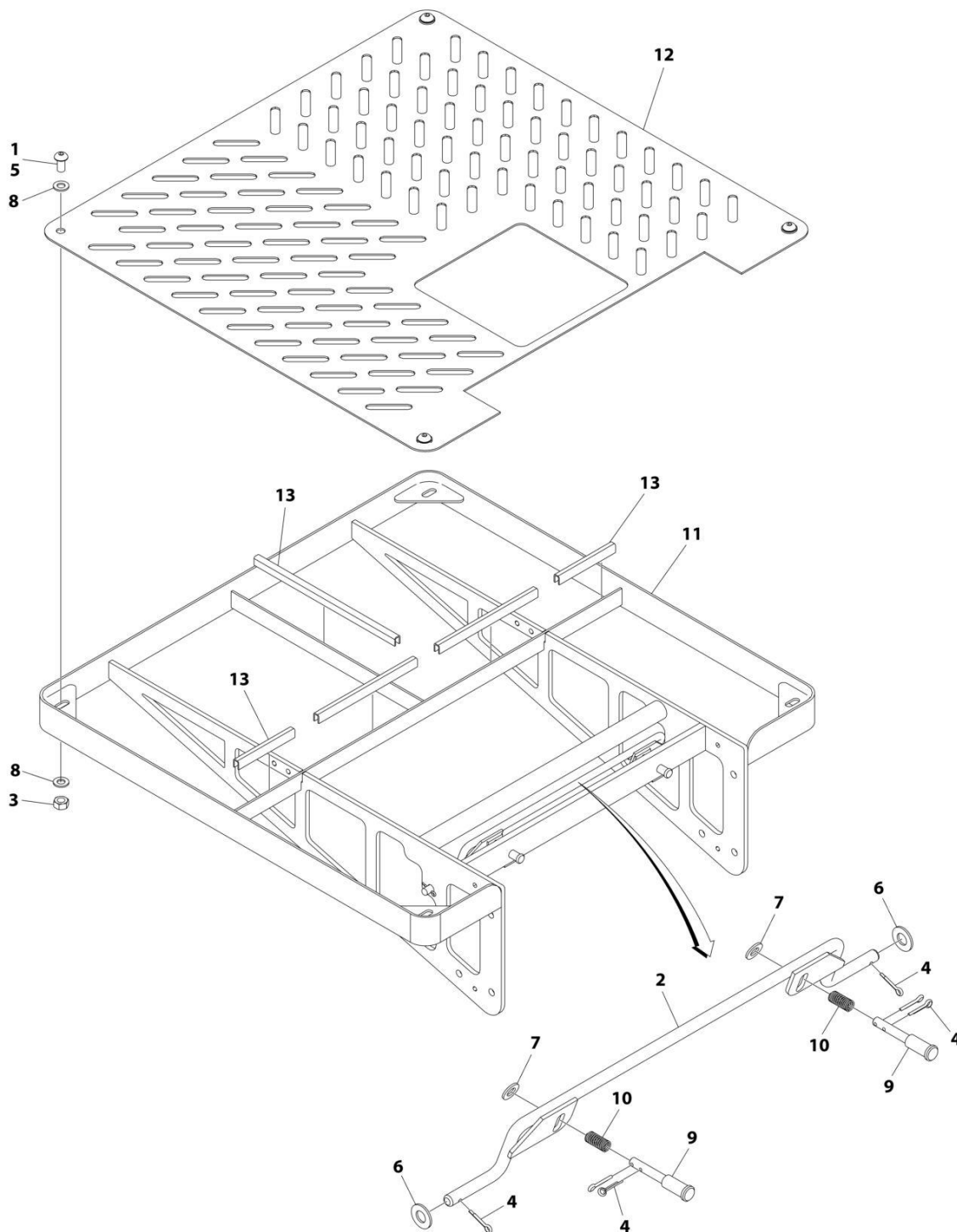

ART_1001228854

SECTION 4 - PLATFORM

FIGURE 4-6. TRAY ASSEMBLY - MANUAL

ITEM	PART NUMBER	QTY	DESCRIPTION	REV
	1001228854	Ref	TRAY ASSEMBLY	B
1	0100011	AR	Compound, Locking	
2	2940165	1	Latch	
3	3291007	4	Nut M10	
4	3450302	6	Pin .09 x 1/2	
5	3900393	4	Screw M10 x 20	
6	4711600	2	Washer 3/8	
7	4811900	2	Washer M8	
8	4812000	8	Washer M10	
9	1001171856	2	Pin, Plunger	
10	1001171869	2	Spring	
11	1001228848	1	Shelf	
12	1001228853	1	Plate	
13	4060805	2.6 in/0.8m	Trim	

SECTION 4 - PLATFORM

FIGURE 4-7. TRAY INSTALLATION - POWER

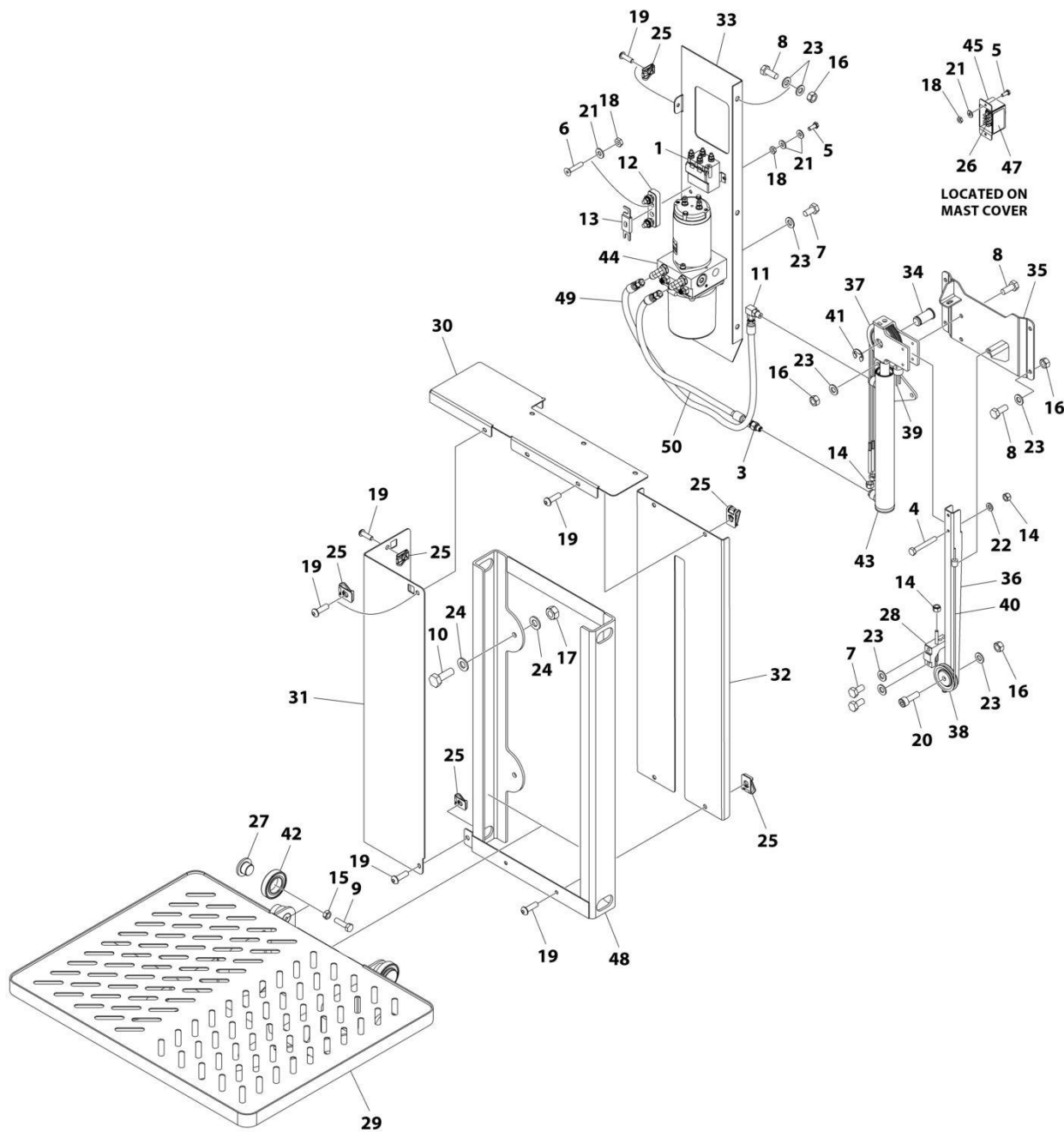

ART_1001228398_E

SECTION 4 - PLATFORM

FIGURE 4-7. TRAY INSTALLATION - POWER

ITEM	PART NUMBER	QTY	DESCRIPTION	REV
	1001228398	Ref	TRAY INSTALLATION	E
1	260269	1	Inverter/Relay	
3	1001231257	1	Fitting, Flow Control	
4	0700617	2	Bolt M6 x 45	
5	0721004	4	Screw #10 x 1/2	
6	0741006	2	Screw #10 x 3/4	
7	0760807	4	Bolt M8 x 14	
8	0760810	10	Bolt M8 x 20	
9	0760814	4	Bolt M8 x 30	
10	0761014	4	Bolt M10 x 30	
11	2220466	1	Fitting, 90 JIC/ORB	
12	2400044	1	Fuse, Mounting Block	
13	2400054	1	Fuse 35Amp	
14	3290605	5	Nut M6	
15	3290801	4	Nut M8	
16	3290807	11	Nut M8	
17	3291007	4	Nut M10	
18	3311005	6	Nut #10	
19	3900364	9	Screw M6 x 20	
20	4031910	1	Capscrew M8 x 30	
21	4711000	8	Washer #10	
22	4811700	2	Washer M6	
23	4811900	18	Washer M8	
24	4812000	8	Washer M10	
25	8305919	9	Nut, Retainer M6	
26	1001164530	1	Switch	
27	1001204754	4	Pad	
28	1001204755	1	Bracket	
29	1001204756	1	Tray	
30	1001204770	1	Cover	
31	1001204771	1	Cover	
32	1001204772	1	Cover	
33	1001204779	1	Plate	
34	1001204783	1	Pin	
35	1001204787	1	Mount, Cylinder	
36	1001204791	1	Link	
37	1001205547	1	Pulley (Double)	
38	1001205548	1	Pulley (Single)	
39	1001205549	1	Cable (Double)	
40	1001205550	1	Cable (Single)	
41	1001205701	1	Circlip	
42	1001205719	4	Bearing	
43	1001205838	1	Power Tray Cylinder Assembly (See Separate Breakdown in CYLINDER SECTION)	
44	1001208602	1	Pump Assembly (See Separate Breakdown in this Section)	
45	1001210379	1	Cover	
46	1001210491	1	Tray Harness (Not Shown - See Separate Breakdown in ELECTRICAL SECTION)	
47	1001210530	1	Decal - Power Tray Up/Down	
48	1001228236	1	Channel	

SECTION 4 - PLATFORM

ITEM	PART NUMBER	QTY	DESCRIPTION	REV
49	1001229115	1	Hose	
50	1001229116	1	Hose	

SECTION 4 - PLATFORM

FIGURE 4-8. PUMP ASSEMBLY - POWER TRAY

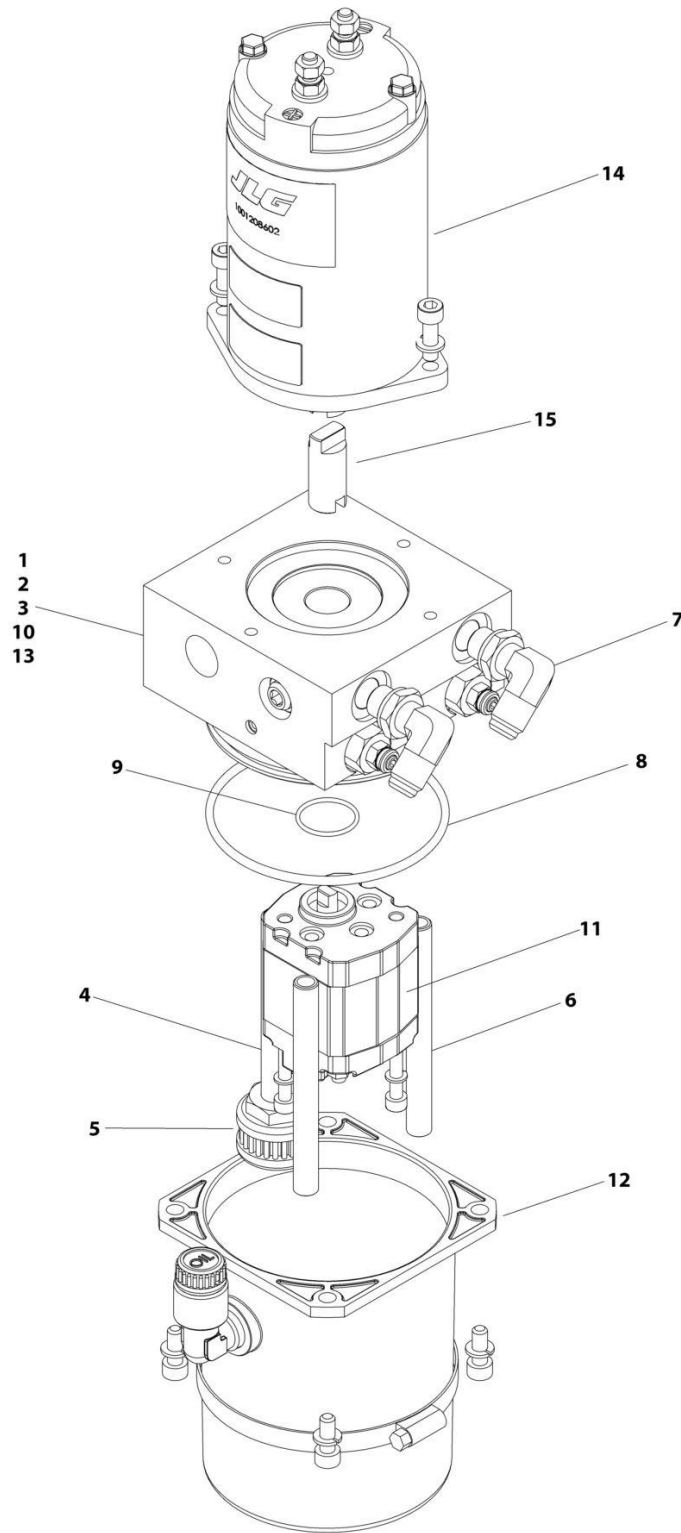

ART_1001208602

SECTION 4 - PLATFORM

FIGURE 4-8. PUMP ASSEMBLY - POWER TRAY

ITEM	PART NUMBER	QTY	DESCRIPTION	REV
	1001208602	Ref	PUMP ASSEMBLY	A
1	70007292	2	Spring, Check Valve	
2	70007293	1	Valve, Piloted Check	
3	70007294	1	Plug	
4	70007295	1	Pipe, Suction	
5	70007296	1	Filter	
6	70007297	2	Pipe, Drain	
7	70007298	2	Fitting 90	
8	70007299	1	O-Ring	
9	70007300	1	O-Ring	
10	70007301	2	Cartridge	
11	70007302	1	Kit, Gear Pump (Includes Screws)	
12	70007303	1	Kit, Tank (Includes Seal, Plugs, Tank, Screws, Washers and Clamp)	
13	70007304	1	Kit, Spool (Includes Spool, Spring and Seals)	
14	70007305	1	Kit, Motor (Includes Motor, Screws and Washers)	
15	70007306	1	Coupling	

SECTION 4 - PLATFORM

FIGURE 4-9. CARGO BELT INSTALLATION (OPTIONAL)

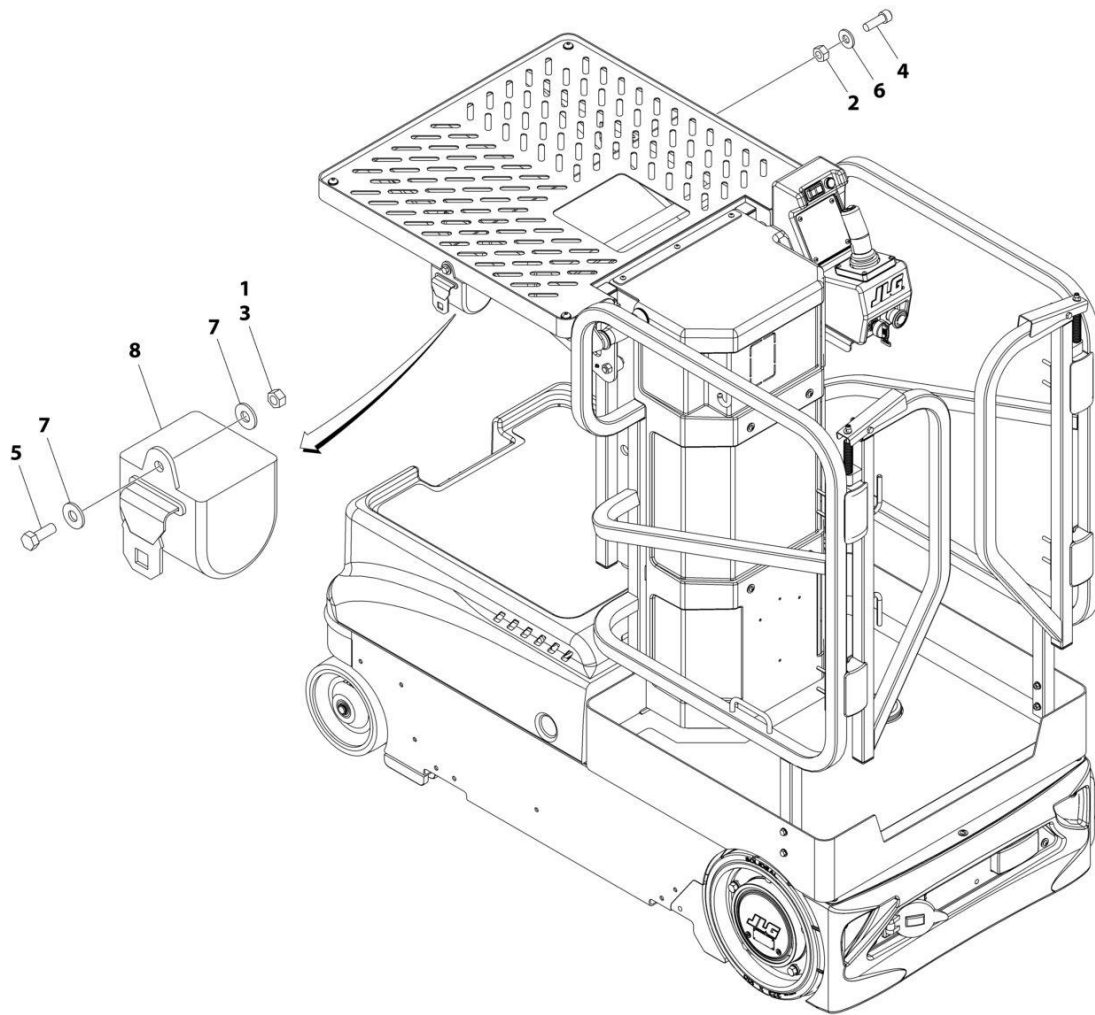

ART_1001091680

SECTION 4 - PLATFORM

FIGURE 4-9. CARGO BELT INSTALLATION (OPTIONAL)

ITEM	PART NUMBER	QTY	DESCRIPTION	REV
	1001091680	Ref	CARGO BELT INSTALLATION	B
1	0100011	AR	Compound, Locking	
2	3311405	1	Nut 1/4	
3	3311501	1	Nut 5/16	
4	3931412	1	Capscrew 1/4 x 3/4	
5	0641507	1	Bolt 5/16 x 7/8	
6	4711400	1	Washer 1/4	
7	4751500	2	Washer 5/16	
8	1001091679	1	Belt, Cargo	

SECTION 4 - PLATFORM

FIGURE 4-10. FLOORMAT INSTALLATION (OPTIONAL)

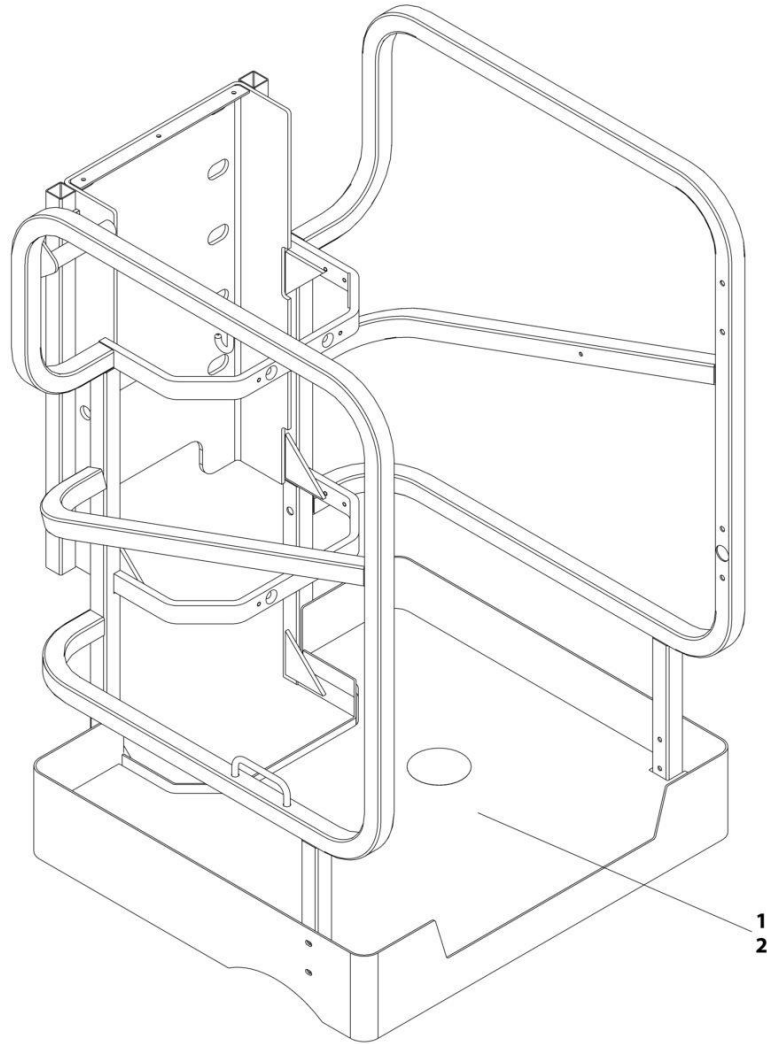

ART_1001222318

SECTION 4 - PLATFORM

FIGURE 4-10. FLOORMAT INSTALLATION(OPTIONAL)

ITEM	PART NUMBER	QTY	DESCRIPTION	REV
1	1001222318	Ref	FLOORMAT INSTALLATION	A
2	8882320	AR	Sealer, Seam	
2	1001206615	1	Floor Mat	

SECTION 4 - PLATFORM

FIGURE 4-11. SCANNER POCKET INSTALLATION (OPTIONAL)

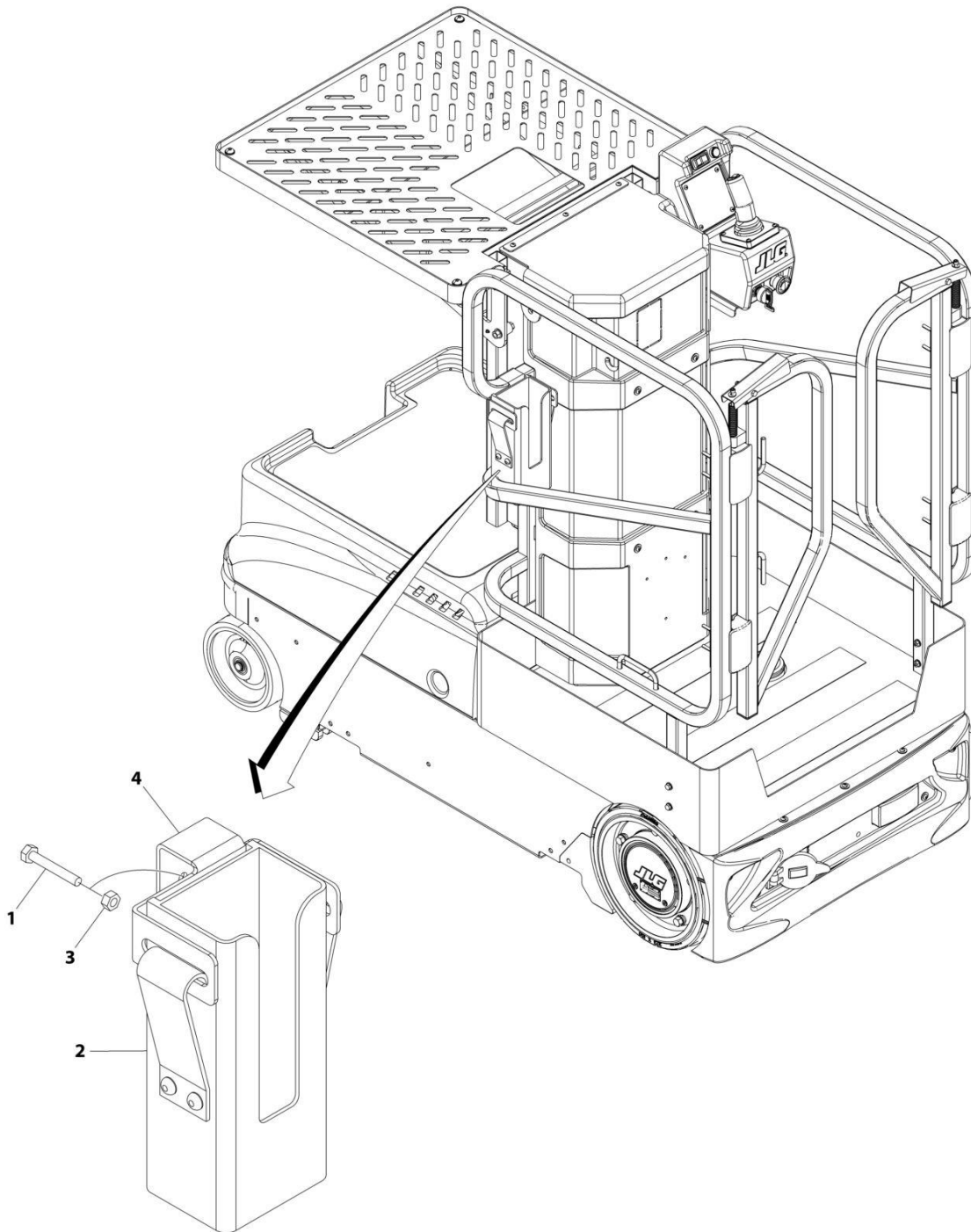

ART_0240112

SECTION 4 - PLATFORM

FIGURE 4-11. SCANNER POCKET INSTALLATION (OPTIONAL)

ITEM	PART NUMBER	QTY	DESCRIPTION	REV
	0240112	Ref	SCANNER POCKET INSTALLATION	B
1	0641414	1	Bolt 1/4 x 1-3/4	
2	1580031	1	Pocket, Scanner	
3	3311405	1	Nut 1/4	
4	4341005	1	Mount	

SECTION 5 - CYLINDER

SECTION 5 - CYLINDER

FIGURE 5-1. LIFT CYLINDER ASSEMBLY

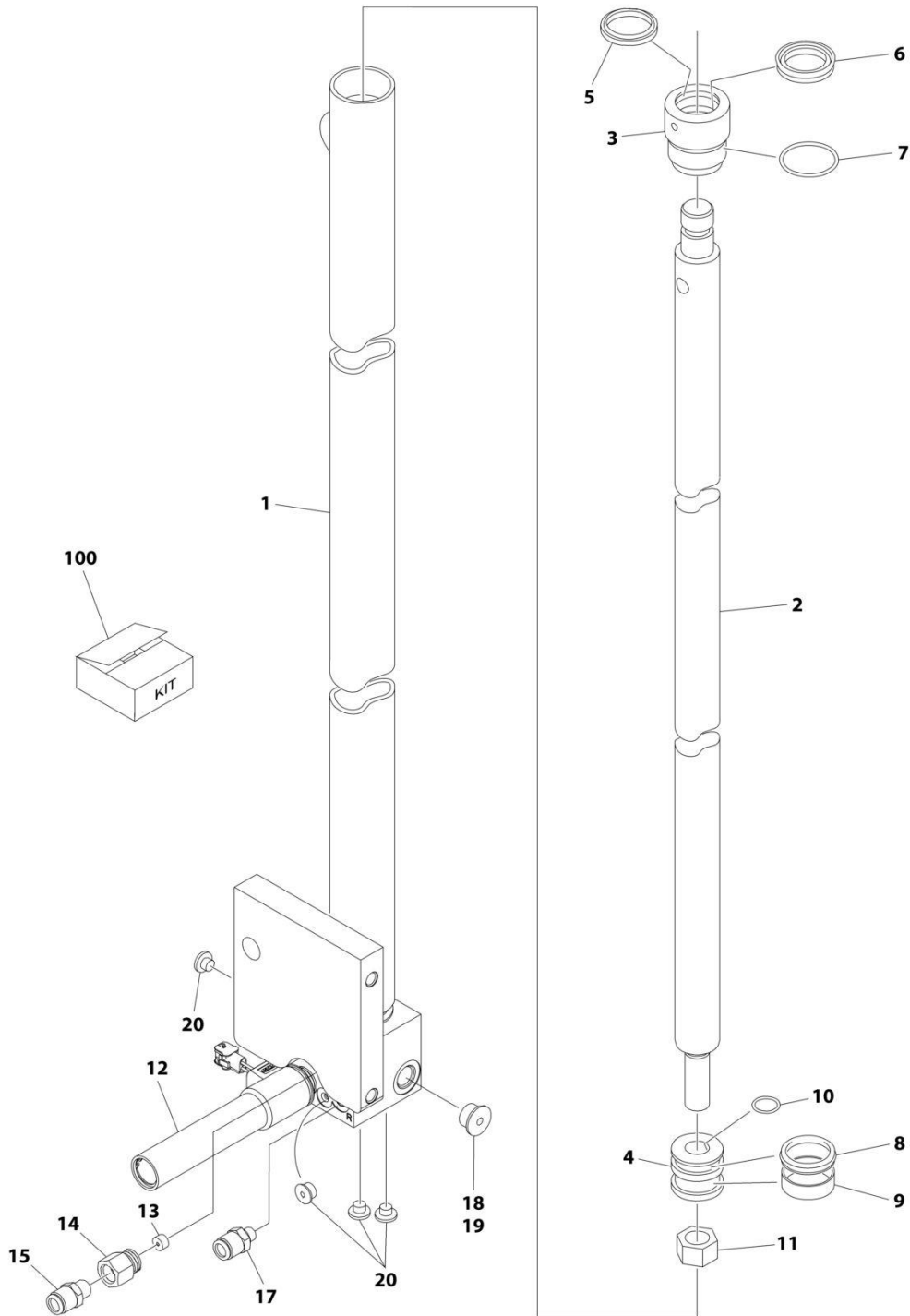

ART_1001225209

SECTION 5 - CYLINDER

FIGURE 5-1. LIFT CYLINDER ASSEMBLY

ITEM	PART NUMBER	QTY	DESCRIPTION	REV
	1001225209	Ref	LIFT CYLINDER ASSEMBLY	B
1	70000991	1	Barrel	
2	70000992	1	Rod	
3	70000993	1	Head	
4	7023392	1	Piston	
5	See Note	NSS	Wiper, Rod (Note: Use Item 100)	
6	See Note	NSS	Seal, Rod (Note: Use Item 100)	
7	See Note	NSS	O-Ring (Note: Use Item 100)	
8	See Note	NSS	Seal, Piston (Note: Use Item 100)	
9	See Note	NSS	Ring, Wear (Note: Use Item 100)	
10	See Note	NSS	O-Ring (Note: Use Item 100)	
11	7023391	1	Nut	
12	70006454	1	Valve, Manual Descent	
12	70006455	1	Coil	
12	70006453	1	Cartridge	
12	70006451	1	Manual Override	
13	70000218	1	Valve, Check	
14	2220591	1	Fitting, Reducer	
15	2221173	1	Fitting	
17	2221172	1	Fitting	
18	70000995	1	Valve, Flow Control	
19	See Note	1	Plug (Note: Not Available - Purchase Locally)	
20	See Note	4	Plug (Note: Not Available - Purchase Locally)	
		Ref	KIT OPTIONS:	
100	7023395	1	Seal Kit (Includes Items 5-10)	
		Ref	TOOL OPTIONS:	
200	7027247	1	Tool, Perma-Push Insert Disconnect (Not Shown)	

SECTION 5 - CYLINDER

FIGURE 5-2. POWER TRAY CYLINDER ASSEMBLY

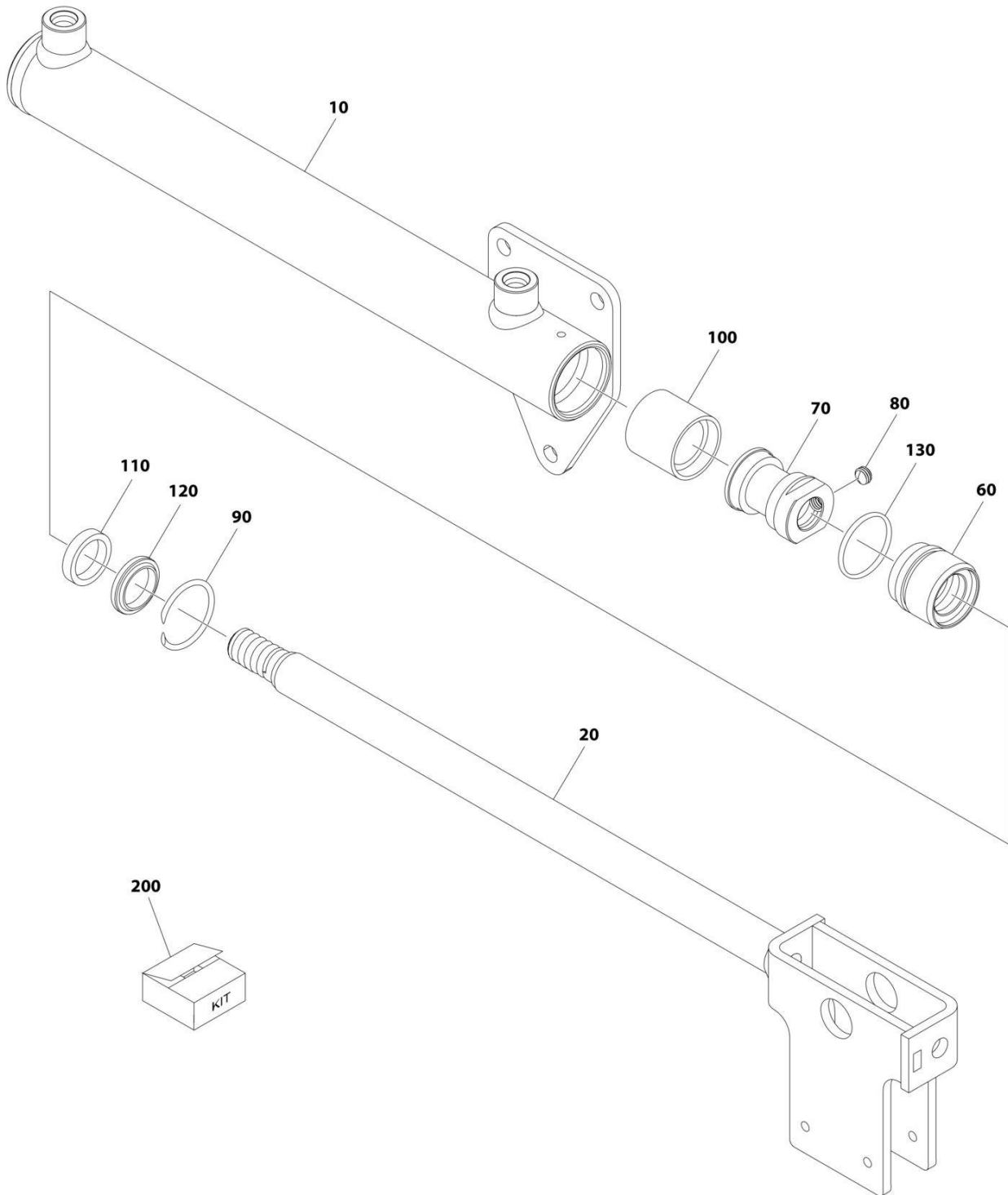

ART_1001205838

SECTION 5 - CYLINDER

FIGURE 5-2. POWER TRAY CYLINDER ASSEMBLY

ITEM	PART NUMBER	QTY	DESCRIPTION	REV
	1001205838	Ref	POWER TRAY CYLINDER ASSEMBLY	A
10	See Note	NSS	Barrel (Note: Purchase Complete Cylinder)	
20	70006456	1	Rod	
60	70022704	1	Head	
70	70022703	1	Piston	
80	70006457	1	Setscrew	
90	70022700	1	Ring, Wire	
100	See Note	NSS	Seal, Piston (Note: Use Item 200)	
110	See Note	NSS	Seal, Rod (Note: Use Item 200)	
120	See Note	NSS	Wiper (Note: Use Item 200)	
130	See Note	NSS	O-RingWiper (Note: Use Item 200)	
200	70022705	1	Seal Kit (Includes Items 100-130)	

SECTION 6 - HYDRAULIC

SECTION 6 - HYDRAULIC

FIGURE 6-1. HYDRAULIC SYSTEM INSTALLATION - STANDARD

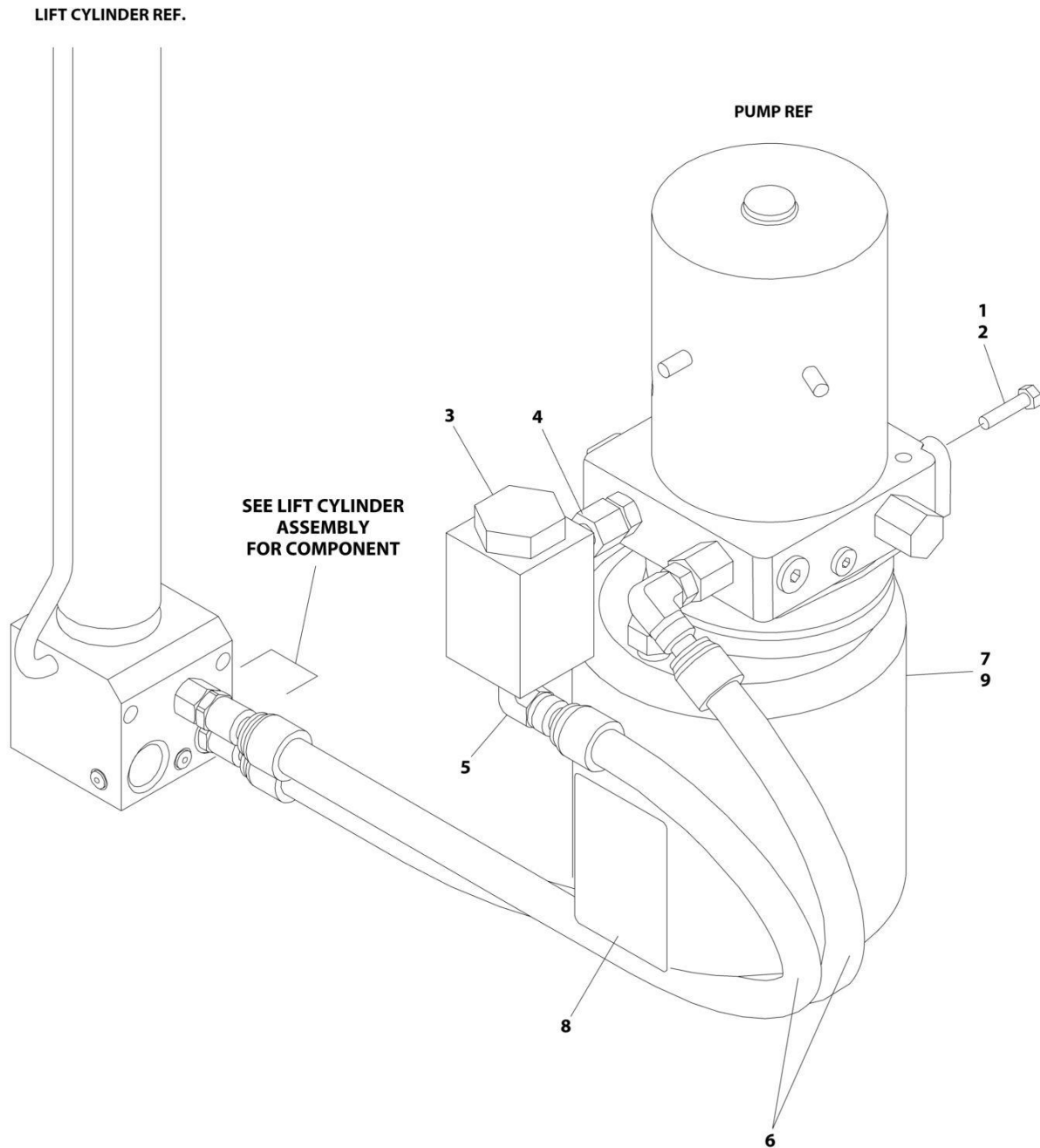

ART_0273546

SECTION 6 - HYDRAULIC

FIGURE 6-1. HYDRAULIC SYSTEM INSTALLATION - STANDARD

ITEM	PART NUMBER	QTY	DESCRIPTION	REV
	0273546	Ref	HYDRAULIC SYSTEM INSTALLATION	E
1	0100011	AR	Compound, Locking	
2	0641606	2	Bolt 3/8 x 3/4	
3	2120183	1	Filter, In-Line Pressure	
4	2221123	1	Fitting, Straight ORFS/ORB	
5	2221185	1	Fitting, 90 ORB/Push Hose	
6	2754025	2	Hose	
7	3600392	1	Pump and Motor Assembly (See Separate Breakdown in CONTROLS SECTION)	
8	1704412	1	Decal - Hydraulic oil	
9	2300014	AR	Fluid, Hydraulic	

SECTION 6 - HYDRAULIC

FIGURE 6-2. HYDRAULIC SYSTEM INSTALLATION - FIRE RESISTANT

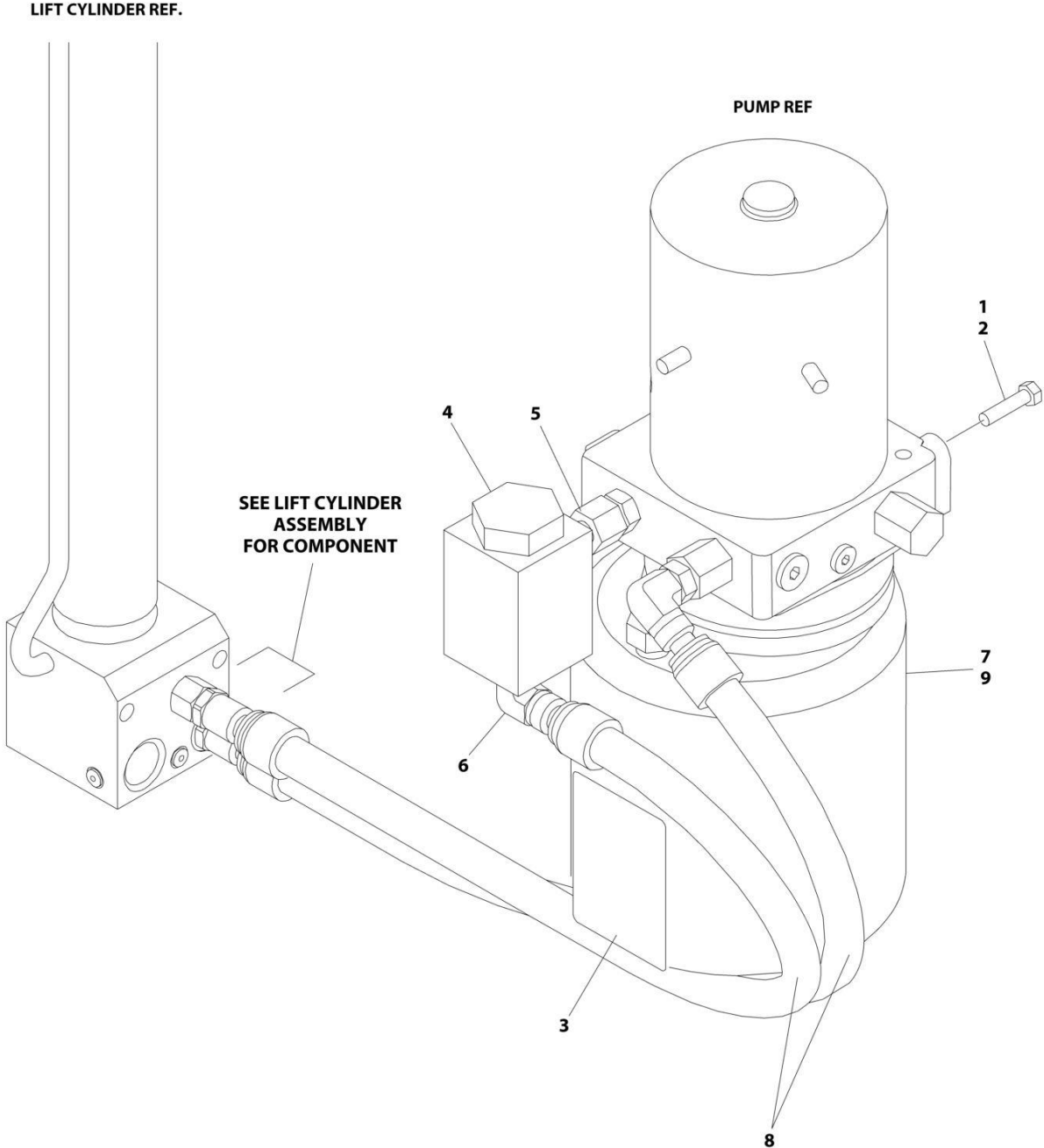

ART_0274181

SECTION 6 - HYDRAULIC

FIGURE 6-2. HYDRAULIC SYSTEM INSTALLATION - FIRE RESISTANT

ITEM	PART NUMBER	QTY	DESCRIPTION	REV
	0274181	Ref	HYDRAULIC SYSTEM INSTALLATION	A
1	0100011	AR	Compound, Locking	
2	0641606	2	Bolt 3/8 x 3/4	
3	1704412	1	Decal - Hydraulic Oil	
4	2120183	1	Filter, In-Line Pressure	
5	2221123	1	Fitting, Straight ORFS/ORB	
6	2221185	1	Fitting, 90 ORB/Push Hose	
7	2300021	AR	Fluid, Hydraulic	
8	2754025	2	Hose	
9	3600392	1	Pump and Motor Assembly (See Separate Breakdown in CONTROLS SECTION)	

SECTION 7 - ELECTRICAL

SECTION 7 - ELECTRICAL

FIGURE 7-1. CABLES INSTALLATION

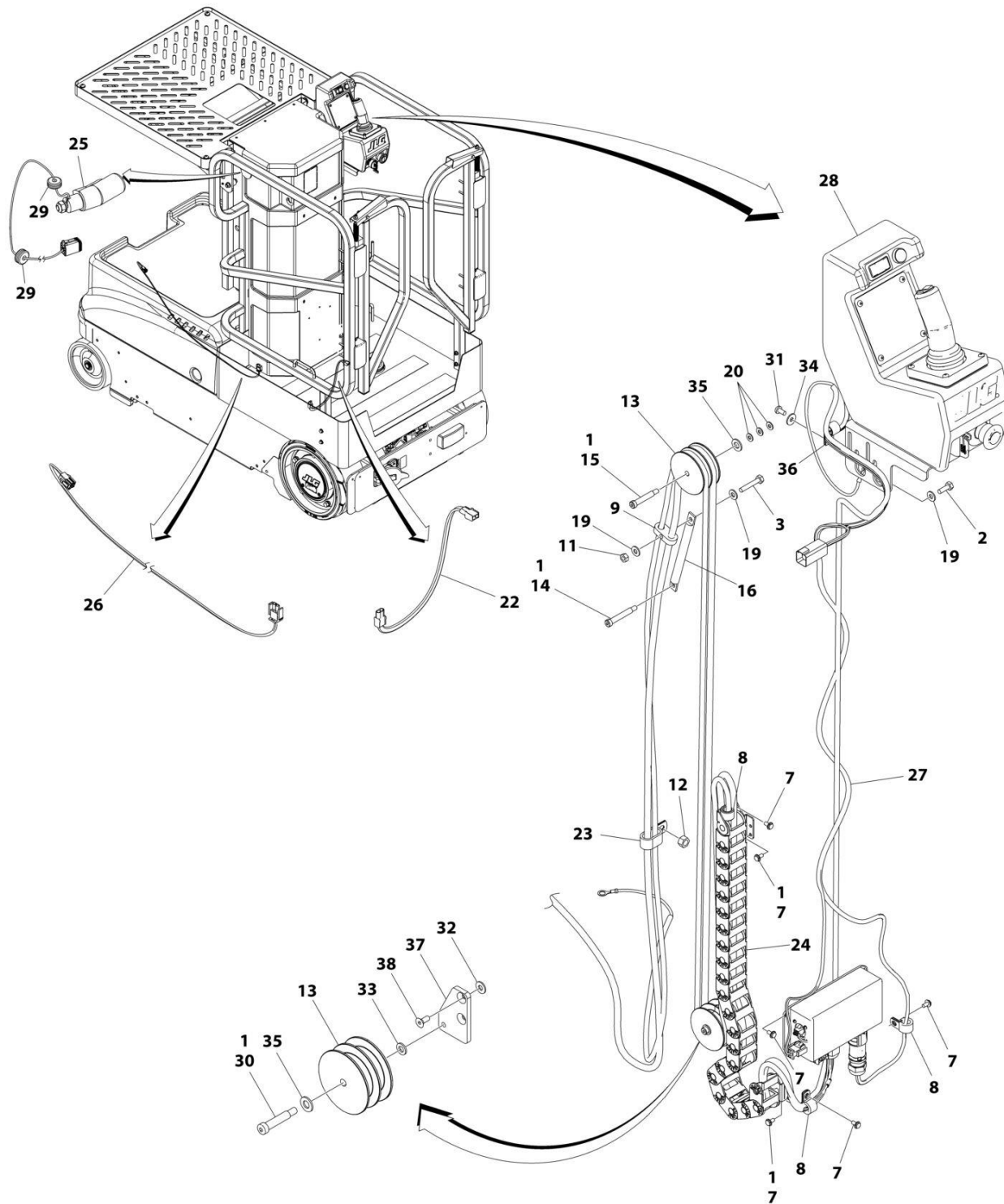

ART_1001206460_F

SECTION 7 - ELECTRICAL

FIGURE 7-1. CABLES INSTALLATION

ITEM	PART NUMBER	QTY	DESCRIPTION	REV
	1001206460	Ref	CABLES INSTALLATION	F
1	0100011	AR	Compound, Locking	
2	0641406	2	Bolt 1/4 x 3/4	
2	0641408	2	Bolt 1/4 x 1	
3	0641412	1	Bolt 1/4 x 1-1/2	
7	0791003	11	Screw #10 x 3/8	
8	1320041	3	Clamp	
9	1320149	1	Clamp	
10	3020038	AR	Grease, Terminal (Not Shown)	
11	3311405	1	Nut 1/4	
12	3311605	1	Nut 3/8	
13	3580344	2	Pulley	
14	3900264	1	Capscrew	
15	3900373	1	Capscrew	
16	4160130	1	Spring	
17	4240018	3	Tie-Strap (Not Shown)	
19	4711400	4	Washer 1/4	
20	4751200	3	Washer #12	
22	1001112143	1	Aux 2 Jumper Harness	
22	4460424	2	Receptacle, Female - 2 Position	
22	4460268	4	Socket, Female	
23	1001116792	1	Clamp	
24	1001207339	1	Ground to Platform Harness (See Separate Breakdown in this Section)	
25	1001208283	1	Switch, Left Hand Control	
26	1001215226	1	Footswitch Jumper Harness (See Separate Breakdown in this Section)	
27	1001227882	1	Platform Controls Harness (See Separate Breakdown in this Section)	
28	1001228495	1	Platform Control Box Assembly (See Separate Breakdown in CONTROLS Section)	
29	1001081050	2	Grommet	
30	3900200	1	Bolt 5/16 X 1-1/4	
31	4191706	1	Screw M6 x 12	
32	4711000	2	Washer #10	
33	4761400	1	Washer 1/4	
34	4811702	1	Washer M6	
35	4811900	2	Washer M8	
36	8406112	1	Clip	
37	1001273307	1	Bracket, Pulley Mount	
38	0741004	2	Screw #10 x 1/2	

SECTION 7 - ELECTRICAL

FIGURE 7-2. ELECTRICAL SYSTEM INSTALLATION - NO BATTERY

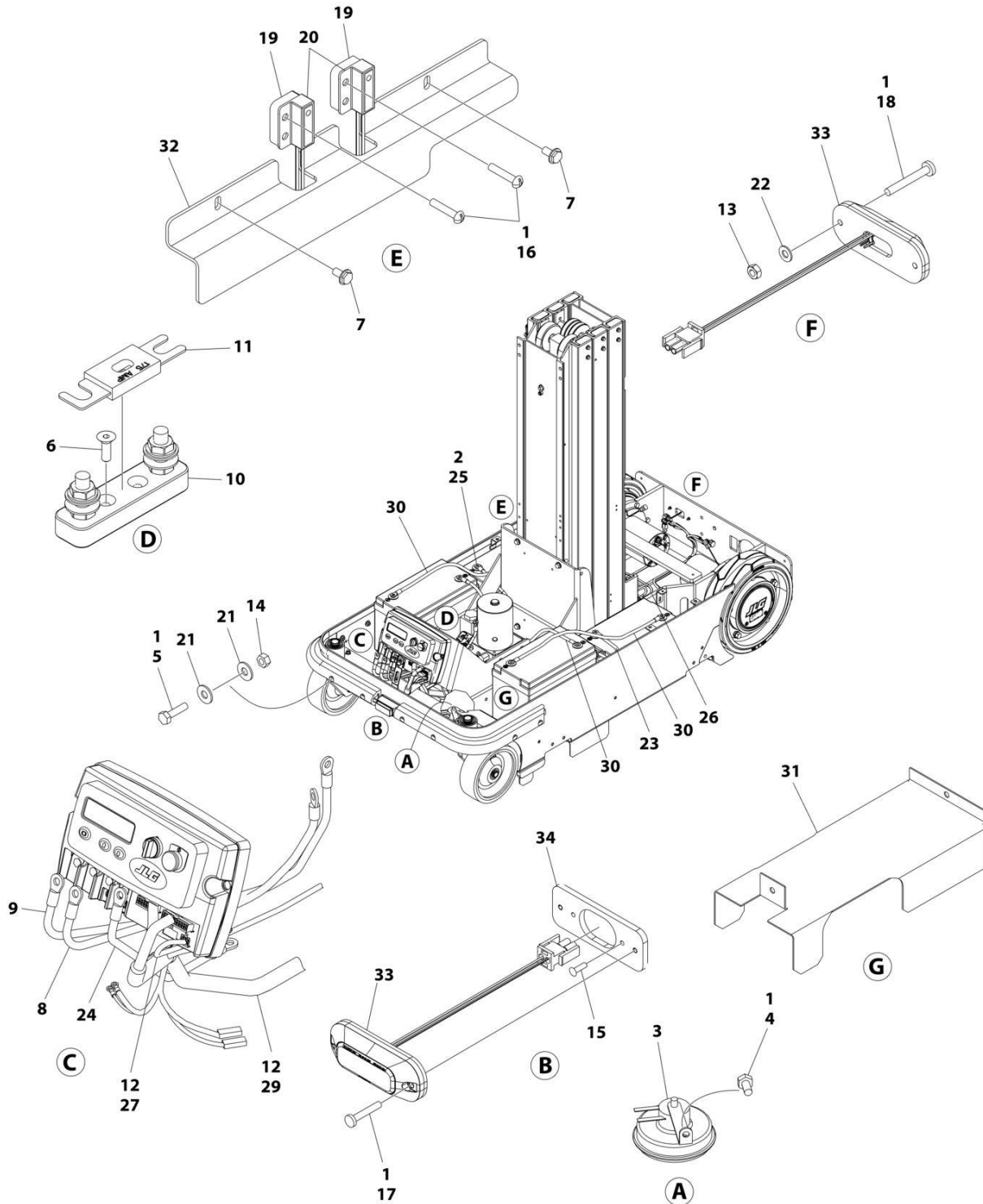

ART_1001272257

SECTION 7 - ELECTRICAL

FIGURE 7-2. ELECTRICAL SYSTEM INSTALLATION - NO BATTERY

ITEM	PART NUMBER	QTY	DESCRIPTION	REV
	1001272257	Ref	ELECTRICAL SYSTEM INSTALLATION - NO BATTERY	A
1	0100011	AR	Compound, Locking	
2	0100051	AR	Grease, Terminal	
3	0140022	1	Alarm	
4	0641404	1	Bolt 1/4 x 1/2	
5	0641408	8	Bolt 1/4 x 1	
6	0741005	2	Screw #10 x 5/8	
7	0791003	2	Screw #10 x 3/8	
8	1060943	1	Cable (GSM P+ to Pump+)	
9	1060944	1	Cable (GSM P- to Pump-)	
10	2400044	1	Fuse, Mounting Block	
11	2400069	1	Fuse 175Amp	
12	3020038	AR	Grease, Contact	
13	3290401	2	Nut M4	
14	3311405	8	Nut 1/4	
15	3820013	2	Rivet	
16	3931016	4	Screw 10-24 x 1	
17	4031509	2	Screw M4 x 25	
18	4031511	2	Screw M4 x 35	
19	4071084	2	Shim	
20	4360514	2	Switch, Proximity	
21	4751400	16	Washer 1/4	
22	4811400	2	Washer M4	
23	4923022	1	Cable (B+ to Fuse)	
24	4923023	1	Cable (Fuse to GSM)	
25	4923024	1	Cable (B- to GSM)	
26	4923028	1	Traction Module Power Harness	
27	4923029	1	Ground Station to Traction Module Harness	
28	4923383	1	Drive Motor Harness (Not Shown) (See Separate Breakdown in ELECTRICAL Section)	
29	4923446	1	Main (MSP) Harness	
30	1001121700	3	Cable (Battery B+ to B-) (Not Shown)	
31	1001229683	2	Plate	
32	1001229684	1	Shield, Wire	
33	1001258016	2	Light, Strobe LED	
34	1001258436	1	Plate	

SECTION 7 - ELECTRICAL

FIGURE 7-3. DRIVE MOTOR HARNESS

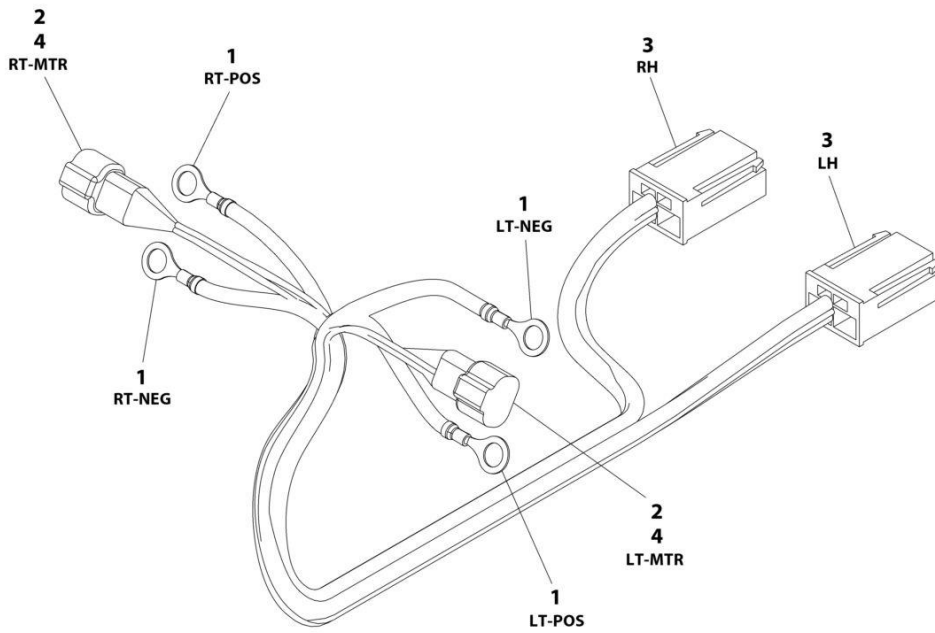

ART_4923383

SECTION 7 - ELECTRICAL

FIGURE 7-3. DRIVE MOTOR HARNESS

ITEM	PART NUMBER	QTY	DESCRIPTION	REV
	4923383	Ref	DRIVE MOTOR HARNESS	E
1	4460738	4	Terminal, Ring	
2	4460897	2	Receptacle, Female - 2 Position	
3	4461108	2	Connector, P&G Drive Motor	
4	4460464	4	Pin, Male	

SECTION 7 - ELECTRICAL

FIGURE 7-4. FOOTSWITCH JUMPER HARNESS

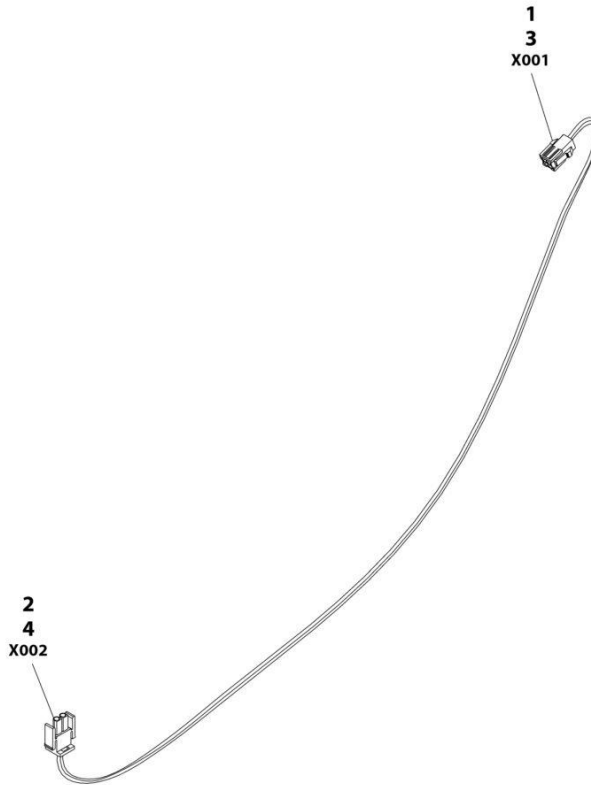

ART_1001215226

SECTION 7 - ELECTRICAL

FIGURE 7-4. FOOTSWITCH JUMPER HARNESS

ITEM	PART NUMBER	QTY	DESCRIPTION	REV
	1001215226	Ref	FOOTSWITCH JUMPER HARNESS	A
1	1001197889	1	Connector, 4 Position	
2	4460320	1	Plug, Male - 2 Position	
3	1001118156	2	Terminal	
4	4460226	2	Socket, Female	

SECTION 7 - ELECTRICAL

FIGURE 7-5. GROUND TO PLATFORM HARNESS

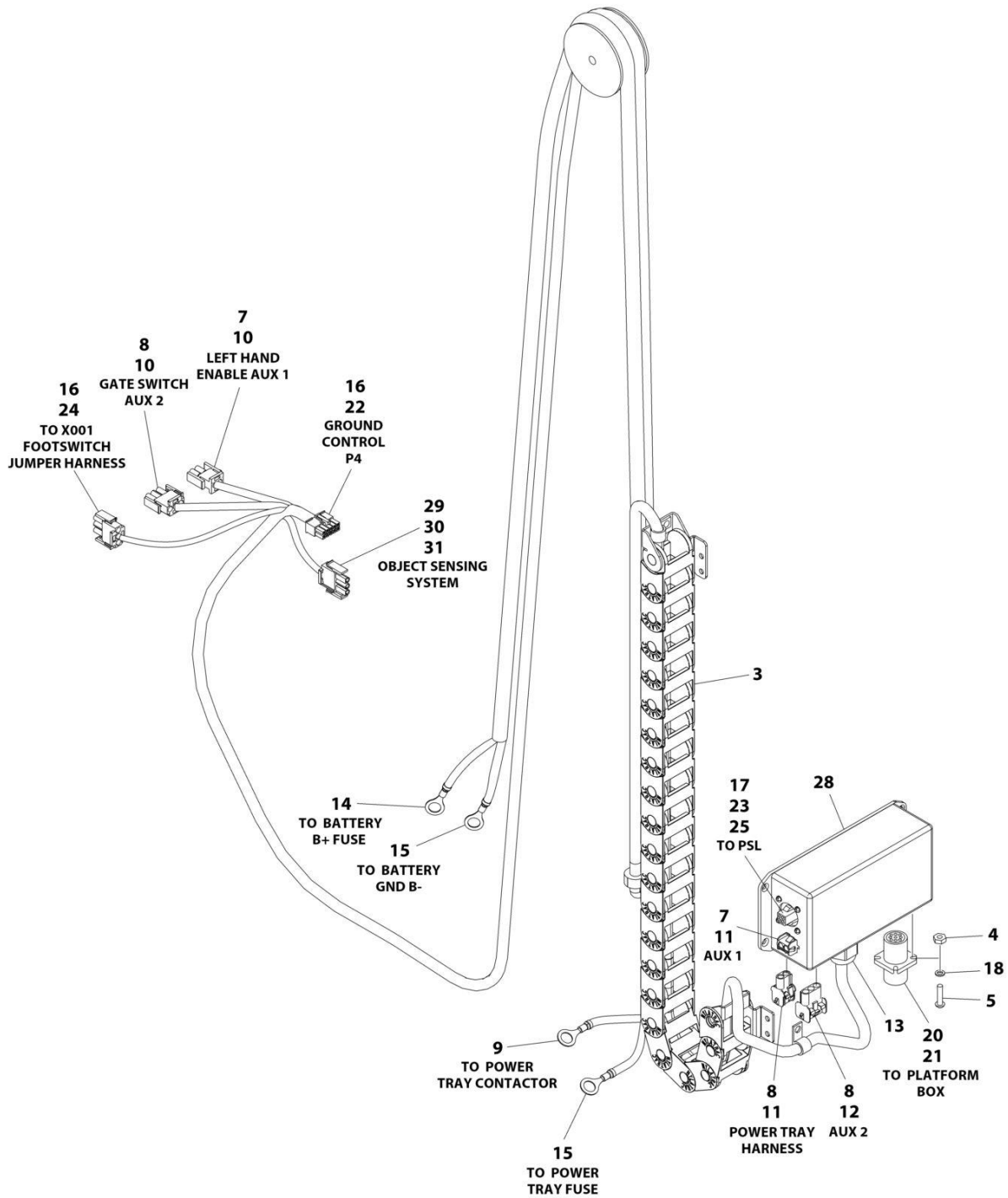

ART_1001207339

SECTION 7 - ELECTRICAL

FIGURE 7-5. GROUND TO PLATFORM HARNESS

ITEM	PART NUMBER	QTY	DESCRIPTION	REV
	1001207339	Ref	GROUND TO PLATFORM HARNESS	E
3	1180397	1	Power Track	
4	3310401	8	Nut #4	
5	3910408	8	Screw, #4 x 1/2	
7	4460226	4	Socket Contact	
8	4460267	7	Pin, Male	
9	4460312	1	Terminal, Ring	
10	4460320	2	Plug, Male 2 - Position	
11	4460424	2	Receptacle, Female - 2 Position	
12	4460445	1	Receptacle, Female - 3 Position	
13	4460633	1	Connector, Strain Relief	
14	4460670	1	Terminal, Ring	
15	4460738	2	Terminal, Ring	
16	4461023	10	Socket, Female	
17	4461025	2	Pin, Male	
18	4760400	8	Washer, #4	
20	1001215633	1	Connector - 9 Position	
21	1001215635	6	Pin, Male	
22	1001153723	1	Connector - 10 Position	
23	1001197889	1	Connector - 4 Position	
24	1001214996	1	Plug, Male - 4 Position	
25	1001215135	1	Plate, Adapter	
28	1001217893	1	Box, Junction	
29	4460465	2	Socket, Female	
30	4460891	1	Plug, Male - 2 Position	
31	1001144295	1	Cap	

SECTION 7 - ELECTRICAL

FIGURE 7-6. LED AND TEMPERATURE SENSOR HARNESS

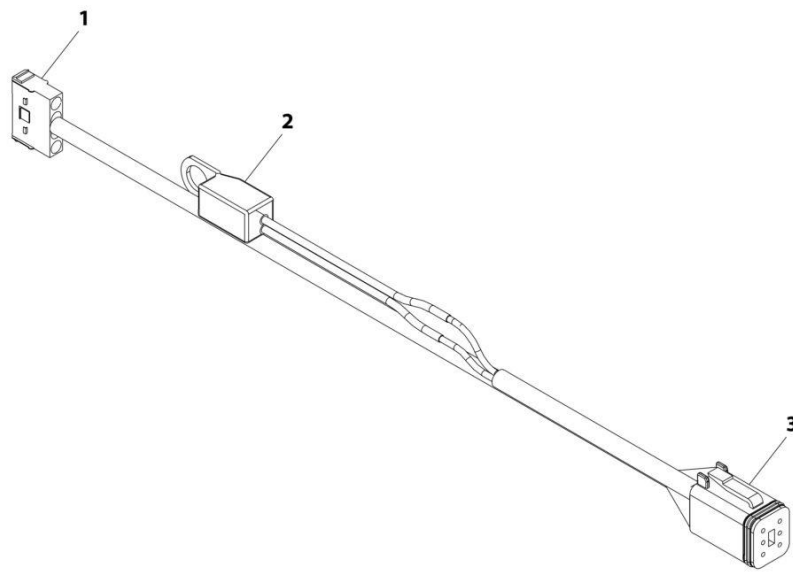

ART_1001109821

SECTION 7 - ELECTRICAL

FIGURE 7-6. LED AND TEMPERATURE SENSOR HARNESS

ITEM	PART NUMBER	QTY	DESCRIPTION	REV
	1001109821	Ref	LED AND TEMPERATURE SENSOR HARNESS	A
1	4460961	1	Receptacle, Female - 4 Position	
1	4460226	4	Socket, Female	
2	1001102771	1	Terminal, Temperature Sensor Ring	
3	4460894	1	Plug, Male - 6 Position	
3	4460465	6	Socket, Female	

SECTION 7 - ELECTRICAL

FIGURE 7-7. PLATFORM BOX POWER HARNESS

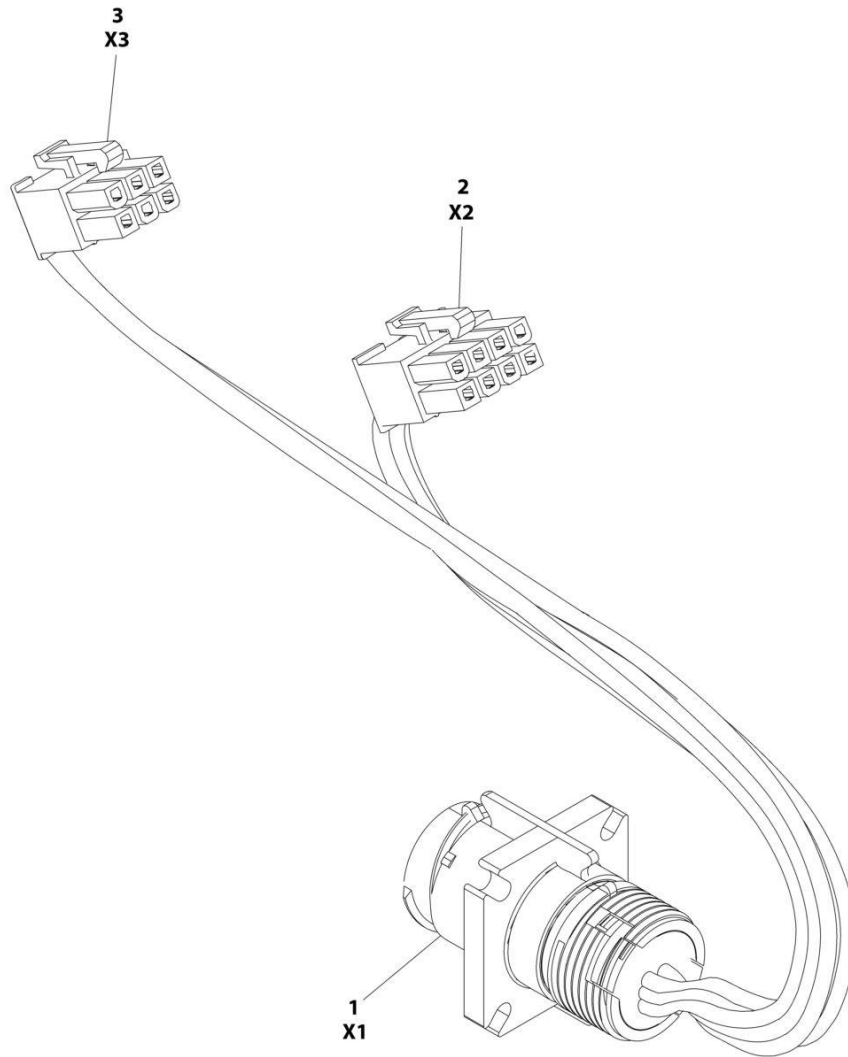

ART_1001227884

SECTION 7 - ELECTRICAL

FIGURE 7-7. PLATFORM BOX POWER HARNESS

ITEM	PART NUMBER	QTY	DESCRIPTION	REV
	1001227884	Ref	PLATFORM BOX POWER HARNESS	A
1	1001215633	1	Connector - 9 Position	
1	1001215635	8	Terminal	
2	1001151629	1	Plug, Male - 8 Position	
2	4461023	5	Socket, Female	
3	1001228387	1	Plug, Male - 6 Position	
3	4461023	3	Socket, Female	

SECTION 7 - ELECTRICAL

FIGURE 7-8. PLATFORM CONTROLS HARNESS

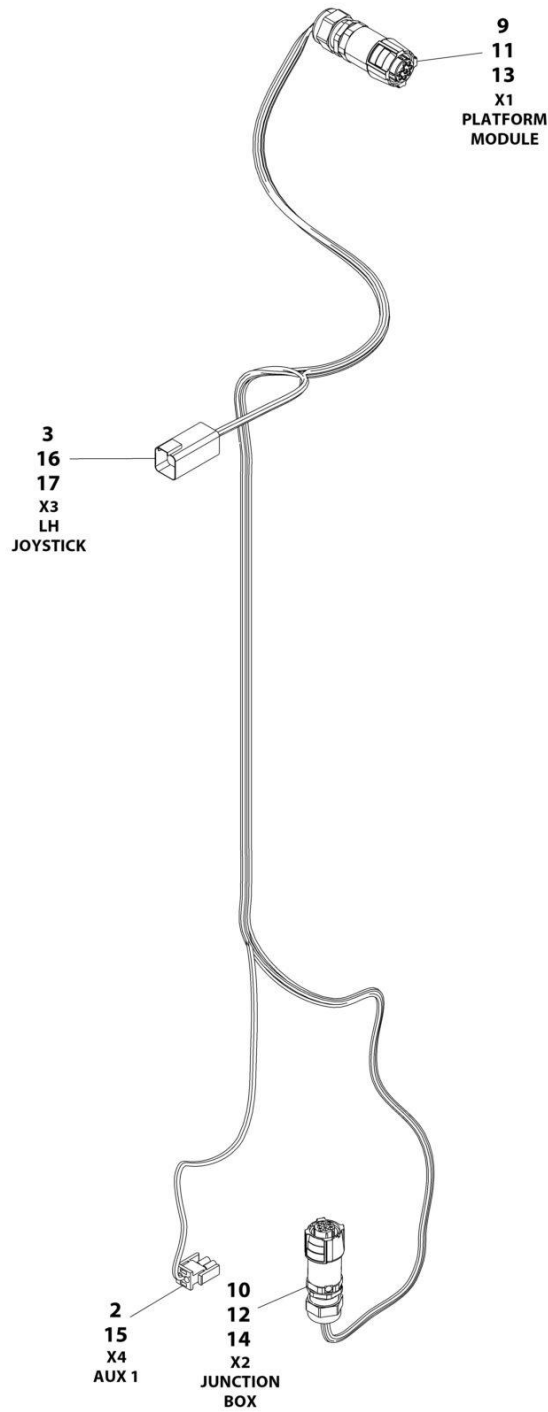

ART_1001227882

SECTION 7 - ELECTRICAL

FIGURE 7-8. PLATFORM CONTROLS HARNESS

ITEM	PART NUMBER	QTY	DESCRIPTION	REV
	1001227882	Ref	PLATFORM CONTROLS HARNESS	E
2	4460267	2	Pin, Male	
3	4460466	1	Terminal, Sealing Plug	
9	1001212654	9	Socket, Female	
10	1001212655	6	Socket, Female	
11	1001212656	1	Backshell	
12	1001212657	1	Backshell	
13	1001212660	1	Connector - 9 Position	
14	1001212661	1	Connector - 9 Position	
15	4460320	1	Plug, Male - 2 Position	
16	4460464	5	Pin, Male	
17	4460899	1	Receptacle, Female - 6 Position	

SECTION 7 - ELECTRICAL

FIGURE 7-9. TRAY HARNESS

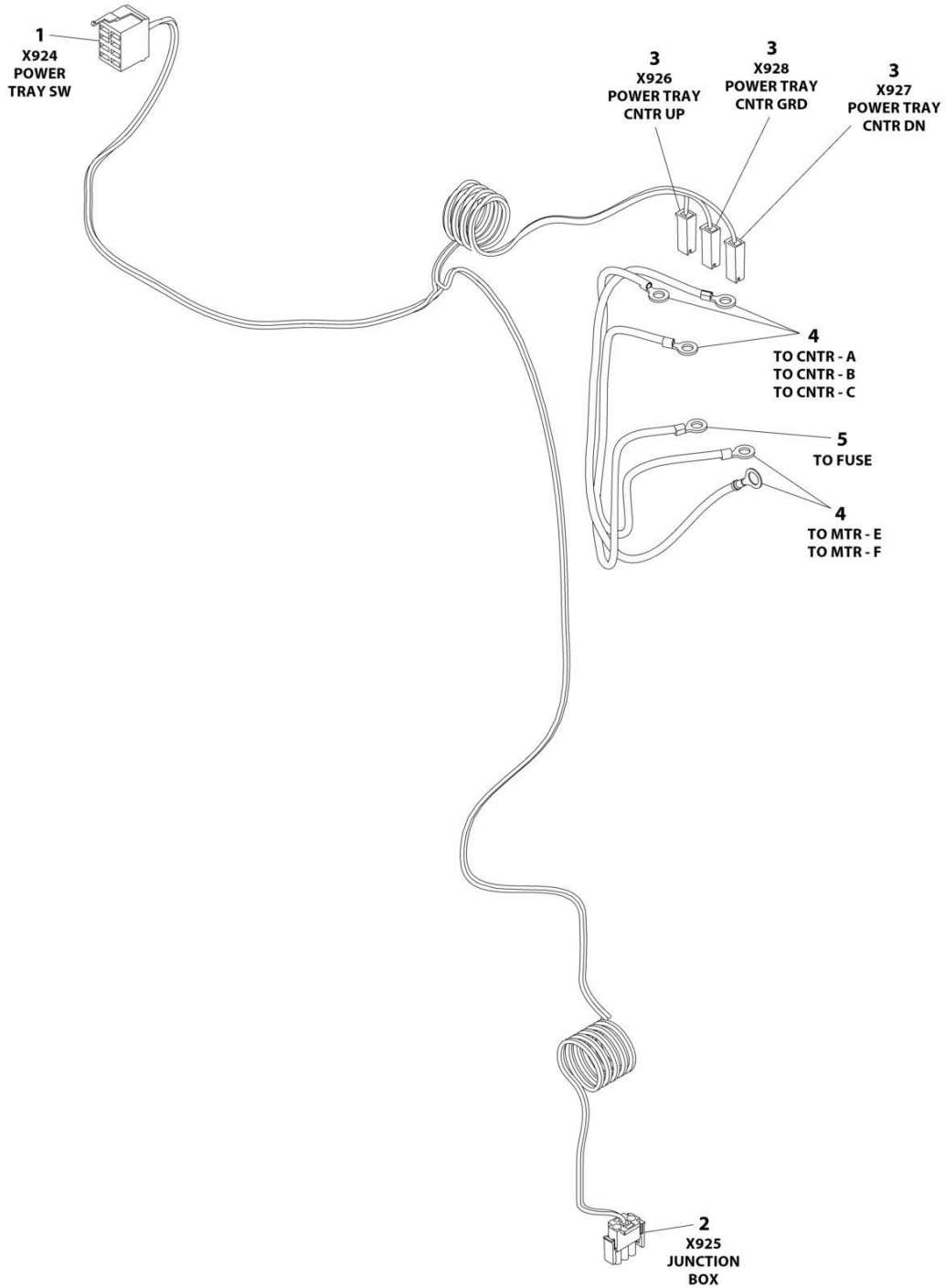

ART_1001210491

SECTION 7 - ELECTRICAL

FIGURE 7-9. TRAY HARNESS

ITEM	PART NUMBER	QTY	DESCRIPTION	REV
	1001210491	Ref	TRAY HARNESS	A
1	8220904	1	Connector - 8 Position	
1	4460829	3	Terminal	
2	4460326	1	Plug, Male 2 - Position	
2	4460268	2	Socket, Female	
3	4460260	3	Cover, Terminal	
3	4460259	3	Terminal	
4	4460312	5	Terminal, Ring	
5	4460738	5	Terminal, Ring	

SECTION 8 - DECALS

SECTION 8 - DECALS

FIGURE 8-1. COMMON DECALS INSTALLATION - STANDARD PAINT

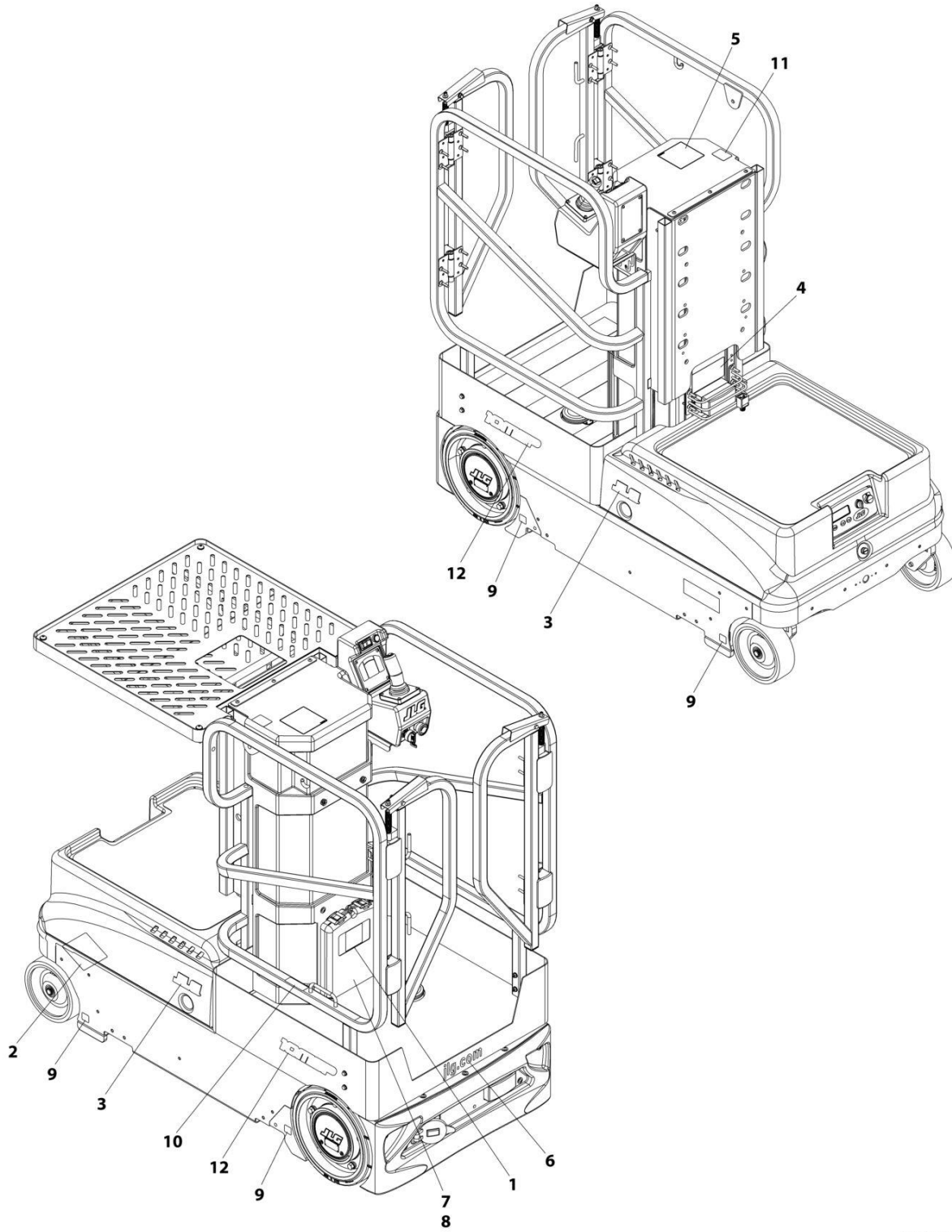

ART_1001271762

SECTION 8 - DECALS

FIGURE 8-1. COMMON DECALS INSTALLATION - STANDARD PAINT

ITEM	PART NUMBER	QTY	DESCRIPTION	REV
	1001271762	Ref	COMMON DECALS INSTALLATION	A
1	1701640	1	Decal - Manual	
2	See Note	NSS	Decal - Bar Code (Note: Not Available for Purchase)	
3	1703681	2	Decal - Logo	
4	1705992	1	Decal - Manual Decent Location	
5	1706131	1	Decal - Danger	
6	1706764	1	Decal - Website	
7	3820032	4	Rivet	
8	8990147	1	Holder, Manual	
9	1001143557	4	Decal - Maximum Wheel Load	
10	1001213582	1	Decal - Lanyard Attach	
11	1001230219	1	Decal - Lift	
12	1001271755	2	Decal, 10MSP	

SECTION 8 - DECALS

FIGURE 8-2. COMMON DECALS INSTALLATION - SPECIAL PAINT

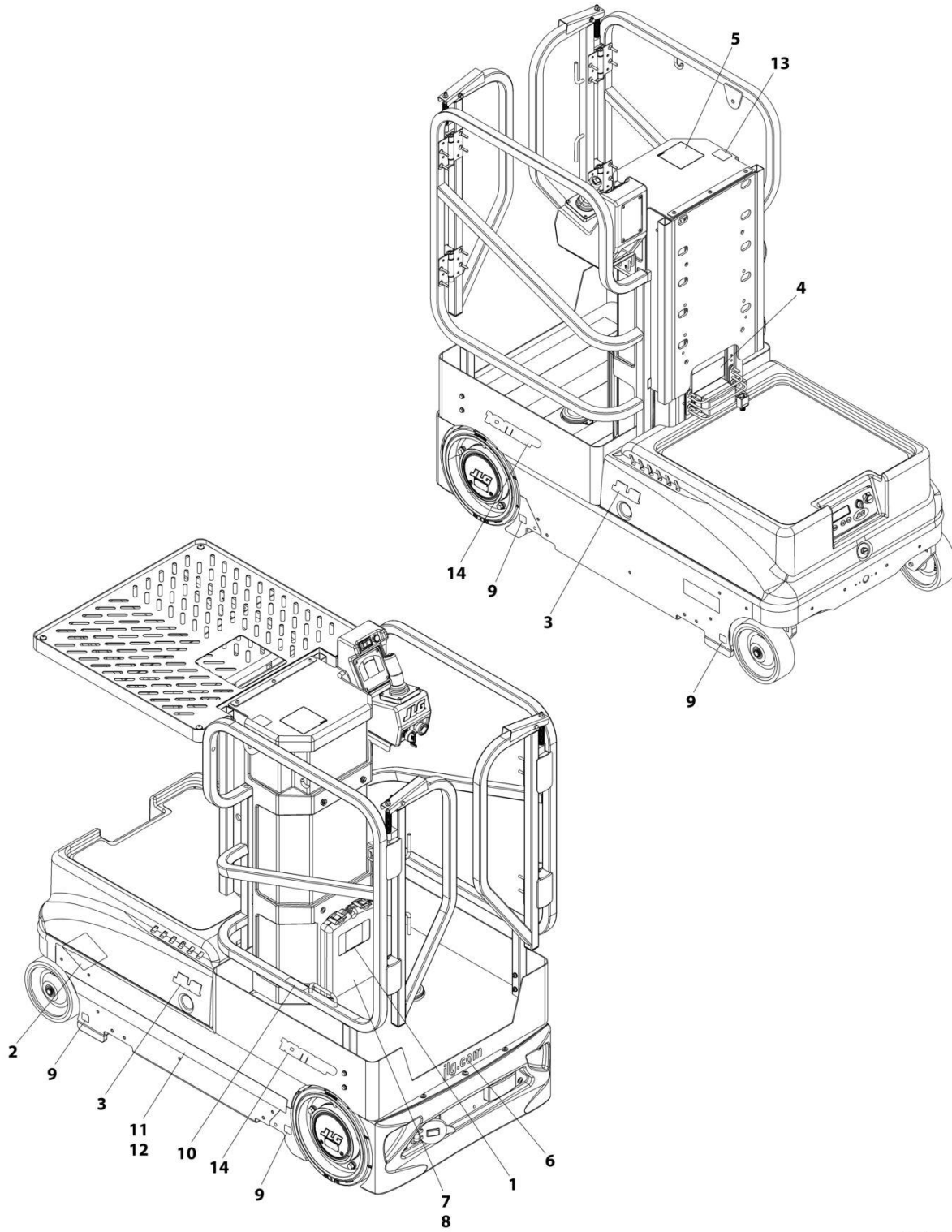

ART_1001271763

SECTION 8 - DECALS

FIGURE 8-2. COMMON DECALS INSTALLATION - SPECIAL PAINT

ITEM	PART NUMBER	QTY	DESCRIPTION	REV
	1001271763	Ref	COMMON DECALS INSTALLATION	A
1	1701640	1	Decal - Manual	
2	See Note	1	Decal - Bar Code (Note: Not Available for Purchase)	
3	1703681	2	Decal - Logo	
4	1705992	1	Decal - Manual Decent Location	
5	1706131	1	Decal - Danger	
6	1706764	1	Decal - Website	
7	3820032	4	Rivet	
8	8990147	1	Holder, Manual	
9	1001143557	4	Decal - Maximum Wheel Load	
10	1001213582	1	Decal - Lanyard Attach	
11	1001230062	1	Decal - Stripe (LH)	
12	1001230063	1	Decal - Stripe (RH)	
13	1001230219	1	Decal - Lift	
14	1001271755	2	Decal - 10MSP	

SECTION 8 - DECALS

FIGURE 8-3. DECAL INSTALLATION - ANSI SPECS (ENGLISH LANGUAGE) (MANUAL TRAY)

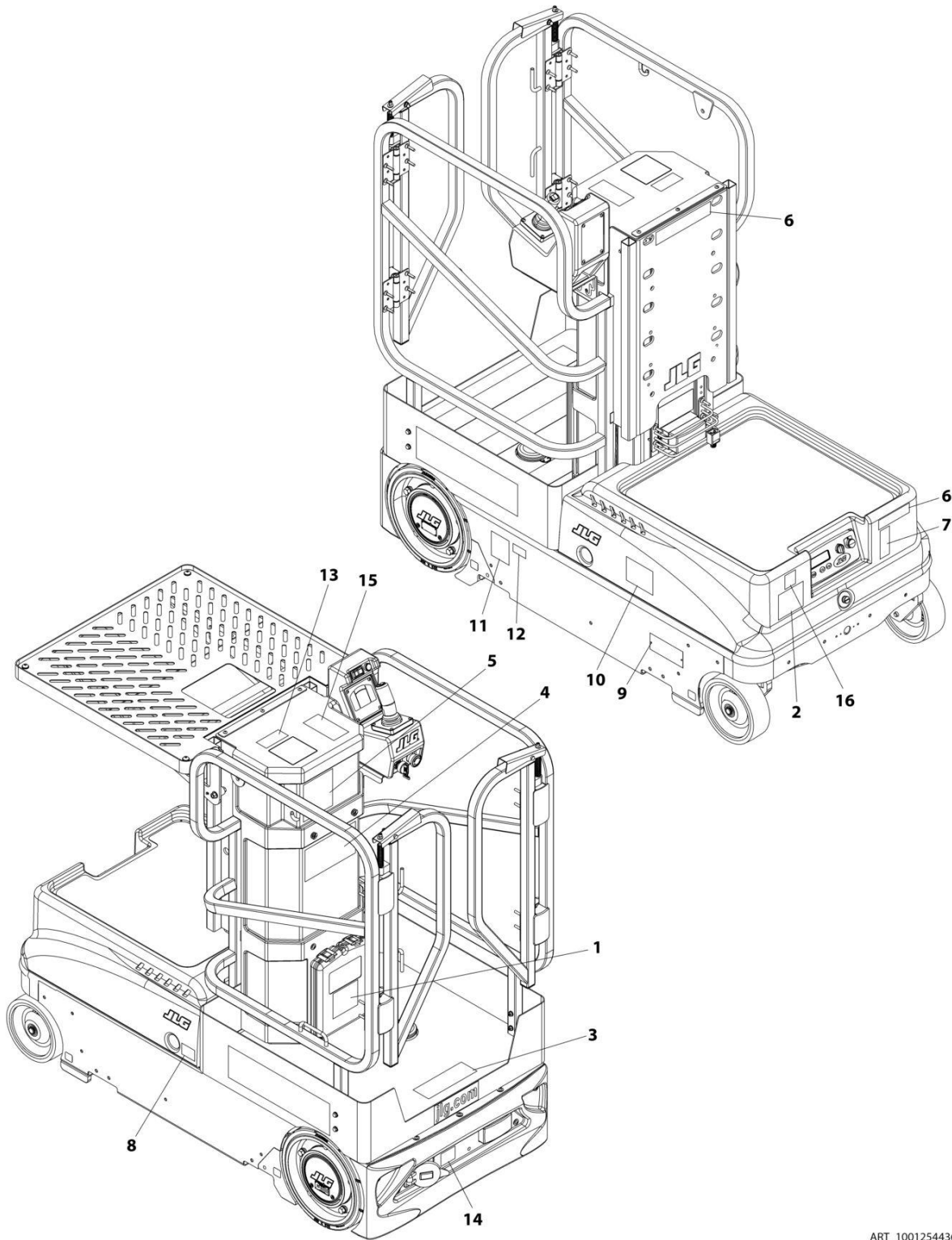

ART_1001254436

SECTION 8 - DECALS

FIGURE 8-3. DECAL INSTALLATION - ANSI SPECS (ENGLISH LANGUAGE) (MANUAL TRAY)

ITEM	PART NUMBER	QTY	DESCRIPTION	REV
	1001254436	Ref	DECALS INSTALLATION	A
1	3251813	1	Decal - USA	
2	1703781	1	Decal - Electrical Hazard	
3	1703786	1	Decal - Crushing Hazard	
4	1705937	1	Decal - Warning	
5	1705938	1	Decal - Danger	
6	1705995	2	Decal - Crushing Hazard	
7	1706617	1	Decal - No Riders	
8	1706740	1	Decal - Battery Disconnect	
9	2080057	2	Fastener	
10	1001131273	1	Decal - Patent	
11	1001223055	1	Decal - Yearly Inspection	
12	1001228370	1	Decal - ICES	
13	1001231801	1	Decal - Prop 65	
14	1001233054	1	Decal - Charger	
15	1001254432	1	Decal - Capacity	
16	1001255190	1	Decal - Capacity	

SECTION 8 - DECALS

FIGURE 8-4. DECAL INSTALLATION - ANSI SPECS (ENGLISH LANGUAGE) (POWER TRAY)

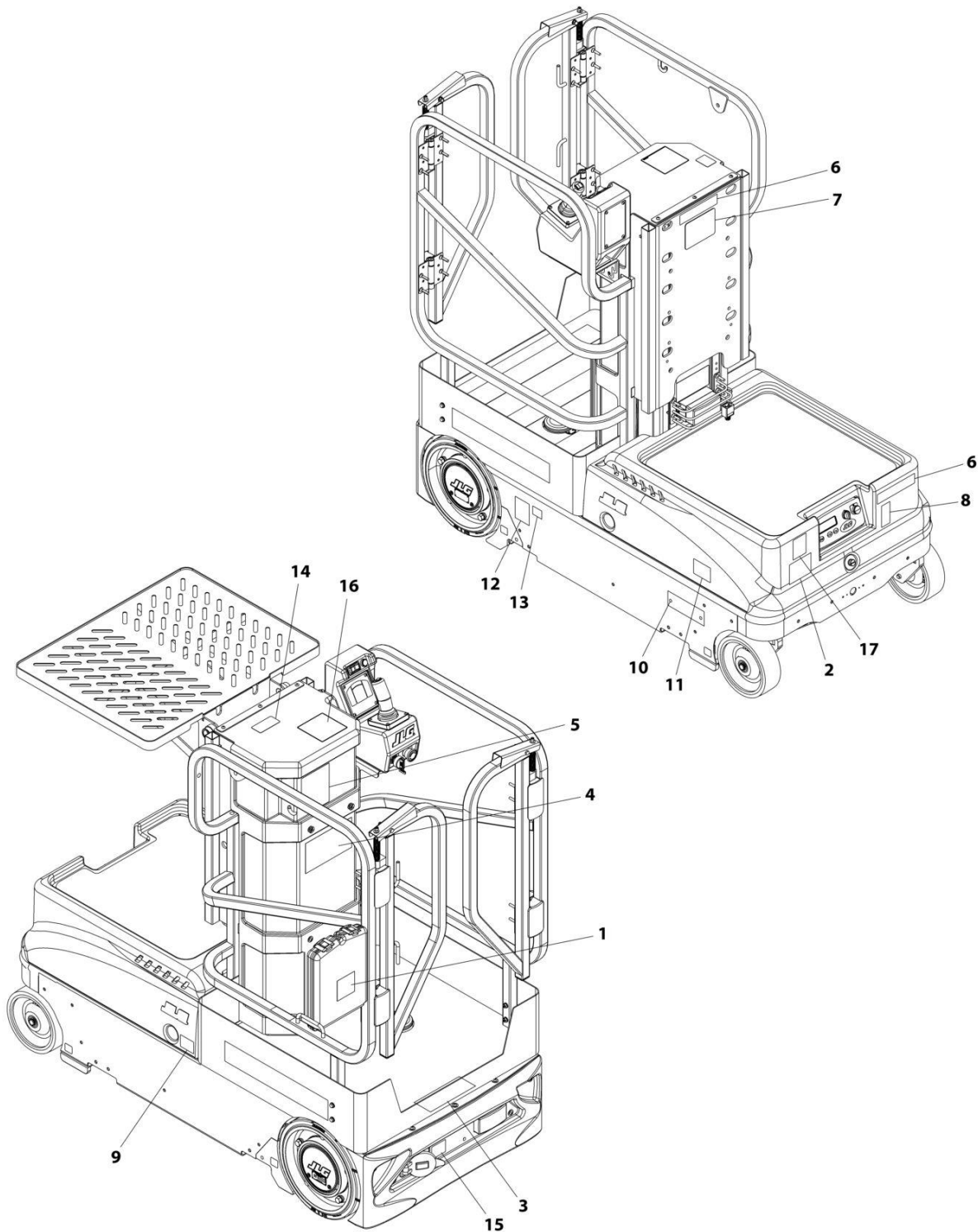

ART_1001254445

SECTION 8 - DECALS

FIGURE 8-4. DECAL INSTALLATION - ANSI SPECS (ENGLISH LANGUAGE) (POWER TRAY)

ITEM	PART NUMBER	QTY	DESCRIPTION	REV
	1001254445	Ref	DECALS INSTALLATION	B
1	1703779	1	Decal - USA (Black & White)	
1	3251813	1	Decal - USA (Color)	
2	1703781	1	Decal - Electrical Hazard	
3	1703786	1	Decal - Crushing Hazard	
4	1705937	1	Decal - Warning	
5	1705938	1	Decal - Danger	
6	1705995	2	Decal - Crushing Hazard	
7	1706302	1	Decal - Pinch Point	
8	1706617	1	Decal - No Riders	
9	1706740	1	Decal - Battery Disconnect	
10	2080057	2	Fastener	
11	1001131273	1	Decal - Patent	
12	1001223055	1	Decal - Yearly Inspection	
13	1001228370	1	Decal - ICES	
14	1001231801	1	Decal - Warning	
15	1001233054	1	Decal - Charger	
16	1001254433	1	Decal - Capacity	
17	1001255190	1	Decal - Capacity	

SECTION 8 - DECALS

FIGURE 8-5. DECAL INSTALLATION - AUSTRALIAN SPECS (ENGLISH LANGUAGE) (MANUAL TRAY)

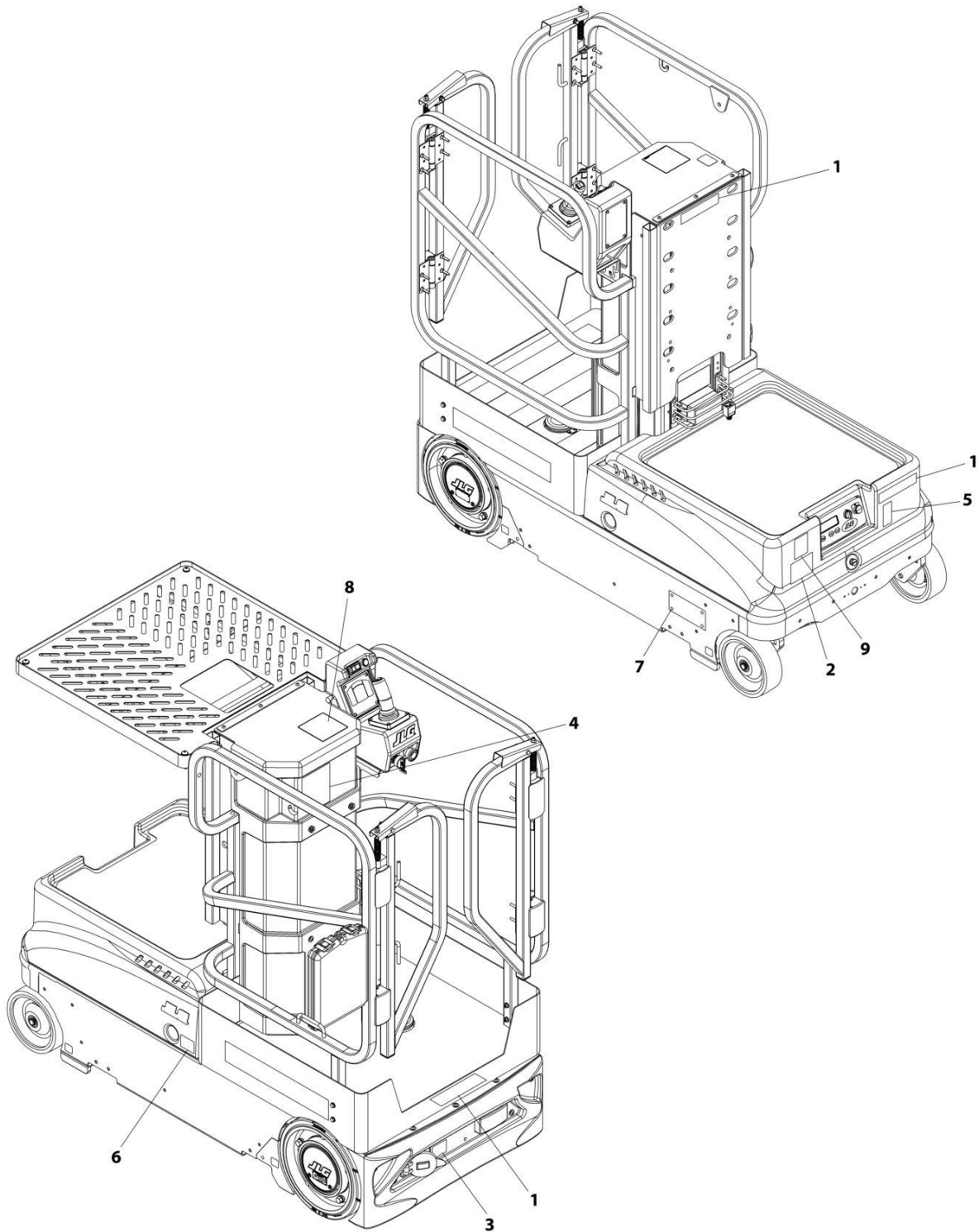

ART_1001254442

SECTION 8 - DECALS

FIGURE 8-5. DECAL INSTALLATION - AUSTRALIAN SPECS (ENGLISH LANGUAGE) (MANUAL TRAY)

ITEM	PART NUMBER	QTY	DESCRIPTION	REV
	1001254442	Ref	DECALS INSTALLATION	A
1	1705099	3	Decal - Crushing Hazard	
2	1705802	1	Decal - VP Electrocutation	
3	1706077	1	Decal - Battery Charging	
4	1706078	1	Decal - Warning	
5	1706617	1	Decal - No Riders	
6	1706740	1	Decal - Battery Disconnect	
7	2080057	4	Fastener	
8	1001207206	1	Decal - Capacity	
9	1001255190	1	Decal - Capacity	

SECTION 8 - DECALS

FIGURE 8-6. DECAL INSTALLATION - AUSTRALIAN SPECS (ENGLISH LANGUAGE) (POWER TRAY)

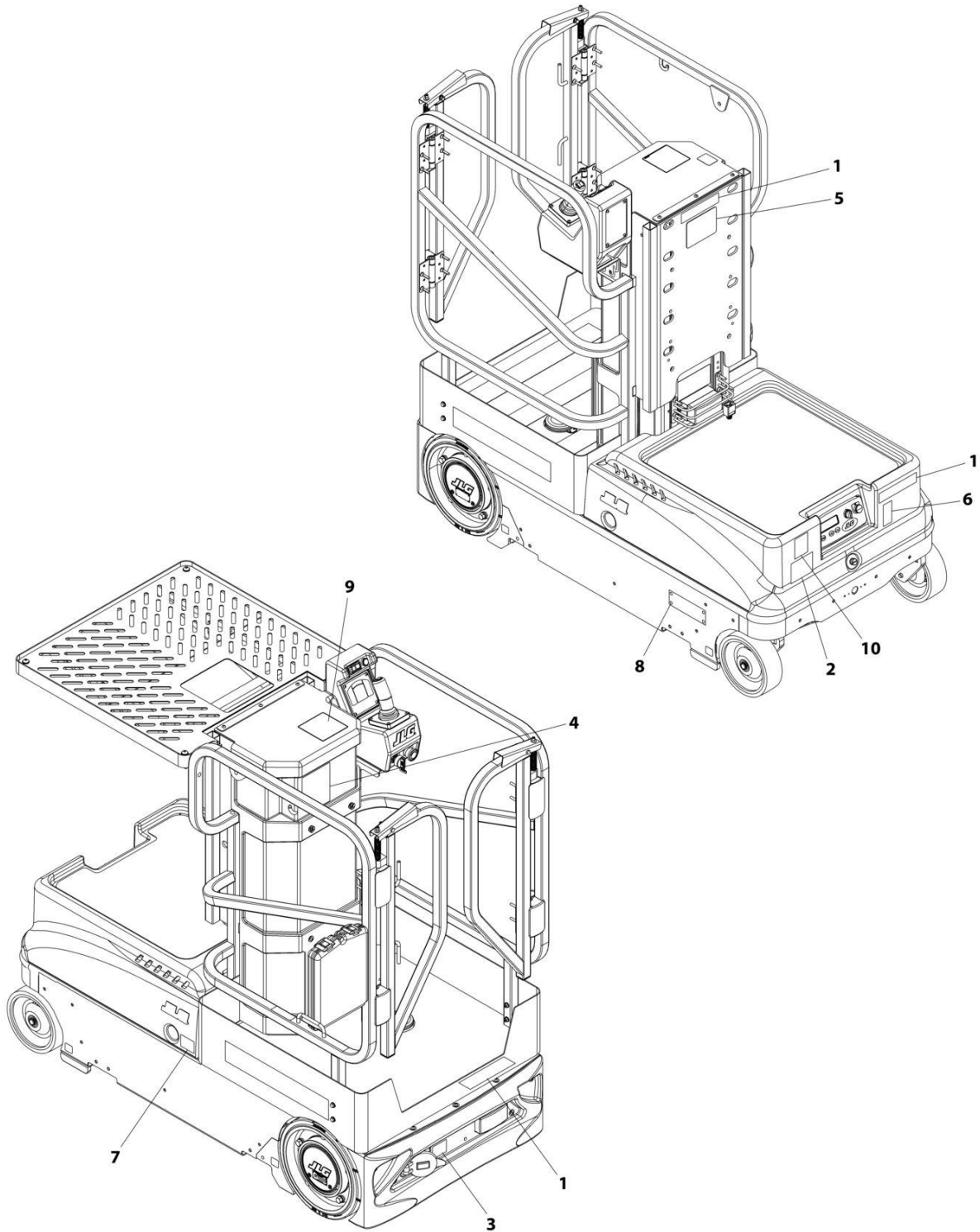

ART_1001254451

SECTION 8 - DECALS

FIGURE 8-6. DECAL INSTALLATION - AUSTRALIAN SPECS (ENGLISH LANGUAGE) (POWER TRAY)

ITEM	PART NUMBER	QTY	DESCRIPTION	REV
	1001254451	Ref	DECALS INSTALLATION	A
1	1705099	3	Decal - Crushing Hazard	
2	1705802	1	Decal - VP Electrocution	
3	1706077	1	Decal - Battery Charging Instruction	
4	1706078	1	Decal - Warning	
5	1706292	1	Decal - Pinch Point	
6	1706617	1	Decal - No Riders	
7	1706740	1	Decal - Battery Disconnect	
8	2080057	4	Fastener	
9	1001202686	1	Decal - Capacity	
10	1001255190	1	Decal - Capacity	

SECTION 8 - DECALS

FIGURE 8-7. DECAL INSTALLATION - BRAZIL SPECS (PORTUGUESE LANGUAGE) (MANUAL TRAY)

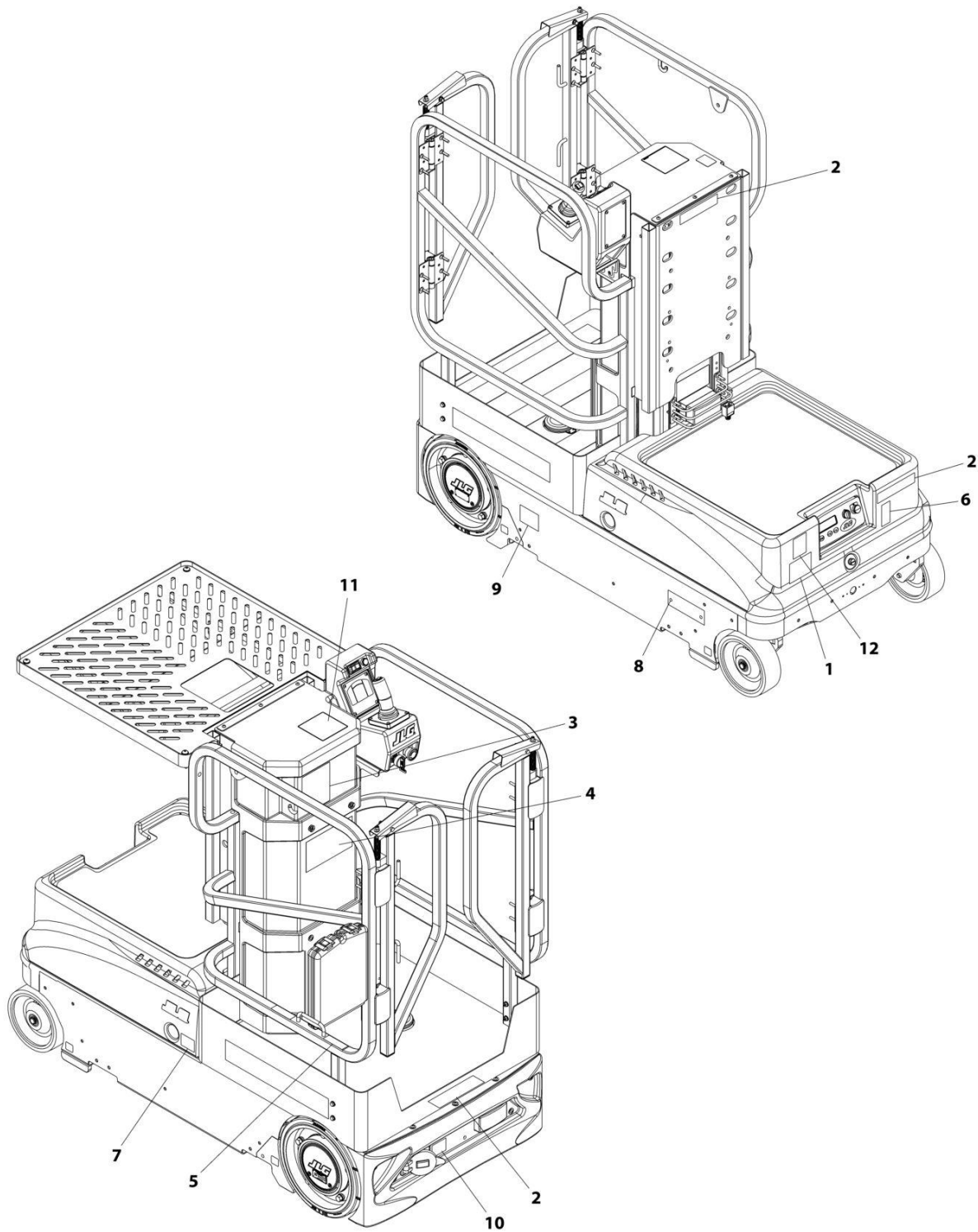

ART_1001254440

SECTION 8 - DECALS

FIGURE 8-7. DECAL INSTALLATION - BRAZIL SPECS (PORTUGUESE LANGUAGE) (MANUAL TRAY)

ITEM	PART NUMBER	QTY	DESCRIPTION	REV
	1001254440	Ref	DECALS INSTALLATION	A
1	1704021	1	Decal - Electrical Hazard	
2	1706086	3	Decal - Crushing Hazard	
3	1706087	1	Decal - Danger	
4	1706088	1	Decal - Warning	
5	1706118	1	Decal - Fall Restraint	
6	1706617	1	Decal - No Riders	
7	1706740	1	Decal - Battery Disconnect	
8	2080057	2	Fastener	
9	1001224052	1	Decal - Yearly Inspection	
10	1001233057	1	Decal - Battery Charging Instruction	
11	1001254432	1	Decal - Capacity	
12	1001255190	1	Decal - Capacity	

SECTION 8 - DECALS

FIGURE 8-8. DECAL INSTALLATION - BRAZIL SPECS (PORTUGUESE LANGUAGE) (POWER TRAY)

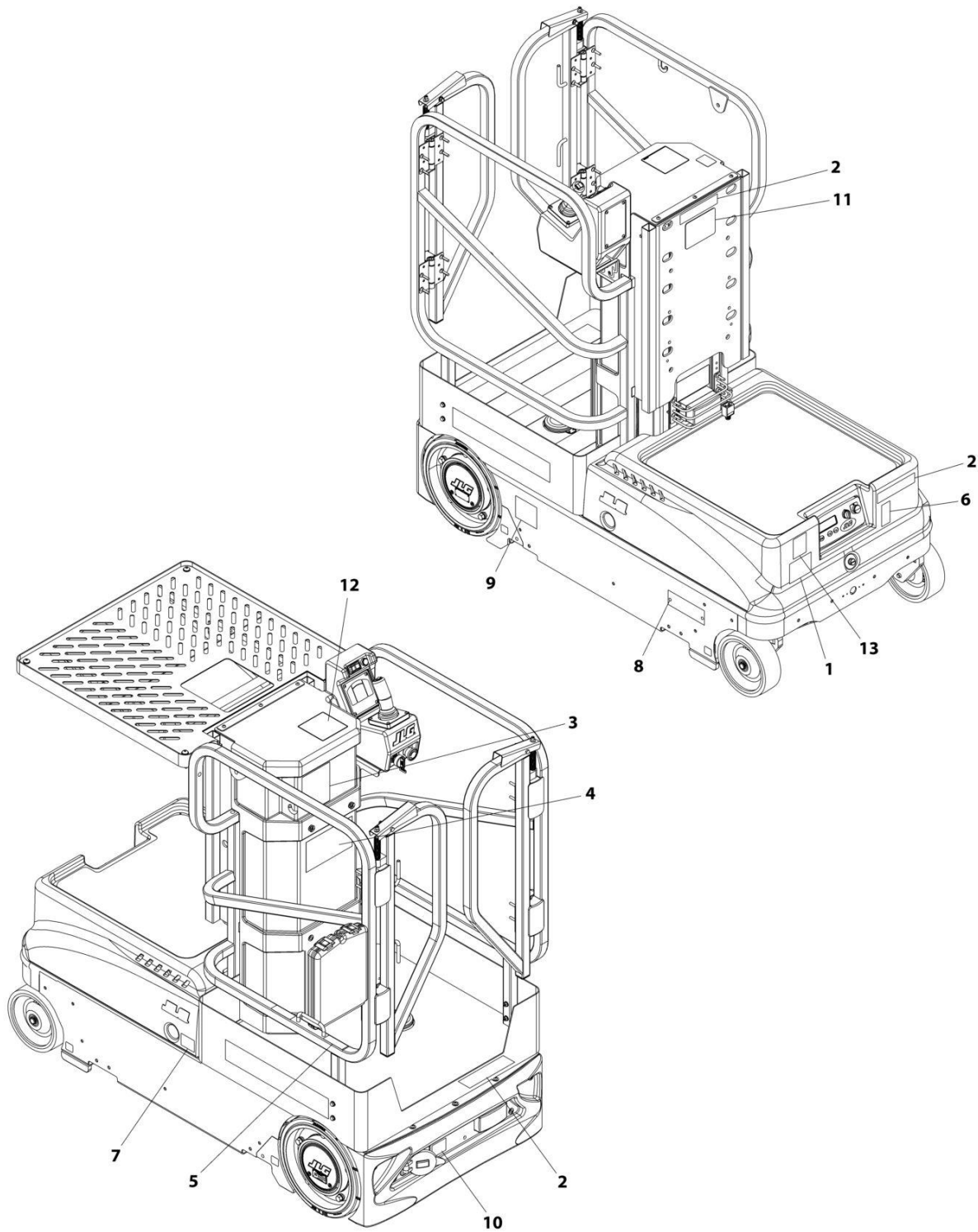

ART_1001254449

SECTION 8 - DECALS

FIGURE 8-8. DECAL INSTALLATION - BRAZIL SPECS (PORTUGUESE LANGUAGE) (POWER TRAY)

ITEM	PART NUMBER	QTY	DESCRIPTION	REV
	1001254449	Ref	DECALS INSTALLATION	A
1	1704021	1	Decal - Electrical Hazard	
2	1706086	3	Decal - Crushing Hazard	
3	1706087	1	Decal - Danger	
4	1706088	1	Decal - Warning	
5	1706118	1	Decal - Fall Restraint	
6	1706617	1	Decal - No Riders	
7	1706740	1	Decal - Battery Disconnect	
8	2080057	2	Fastener	
9	1001224052	1	Decal - Yearly Inspection	
10	1001233057	1	Decal - Battery Charging Instruction	
11	1001233728	1	Decal - Pinch Point	
12	1001254433	1	Decal - Capacity	
13	1001255190	1	Decal - Capacity	

SECTION 8 - DECALS

FIGURE 8-9. DECAL INSTALLATION - CE & UK CA SPECS (ENGLISH LANGUAGE) (MANUAL TRAY)

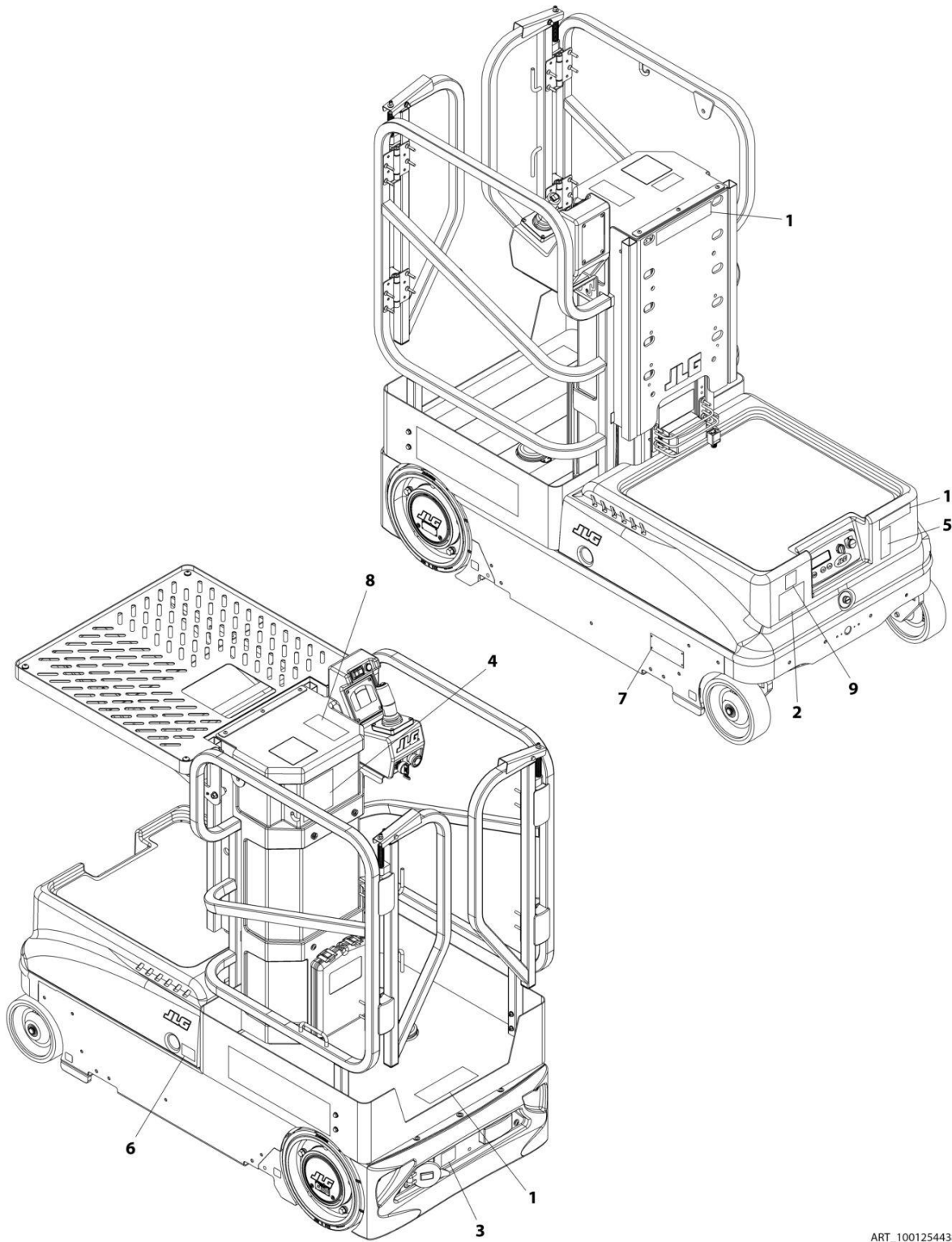

ART_1001254438

SECTION 8 - DECALS

FIGURE 8-9. DECAL INSTALLATION - CE & UK CA SPECS (ENGLISH LANGUAGE) (MANUAL TRAY)

ITEM	PART NUMBER	QTY	DESCRIPTION	REV
	1001254438	Ref	DECALS INSTALLATION	A
1	1705099	3	Decal - Crushing Hazard	
2	1705802	1	Decal - VP Electrocutation	
3	1706077	1	Decal - Battery Charging Instruction	
4	1706078	1	Decal - Warning	
5	1706617	1	Decal - No Riders	
6	1706740	1	Decal - Battery Disconnect	
7	2080057	4	Fastener	
8	1001207206	1	Decal - Capacity	
9	1001255190	1	Decal - Capacity	

SECTION 8 - DECALS

FIGURE 8-10. DECAL INSTALLATION - CE & UK CA SPECS (ENGLISH LANGUAGE) (POWER TRAY)

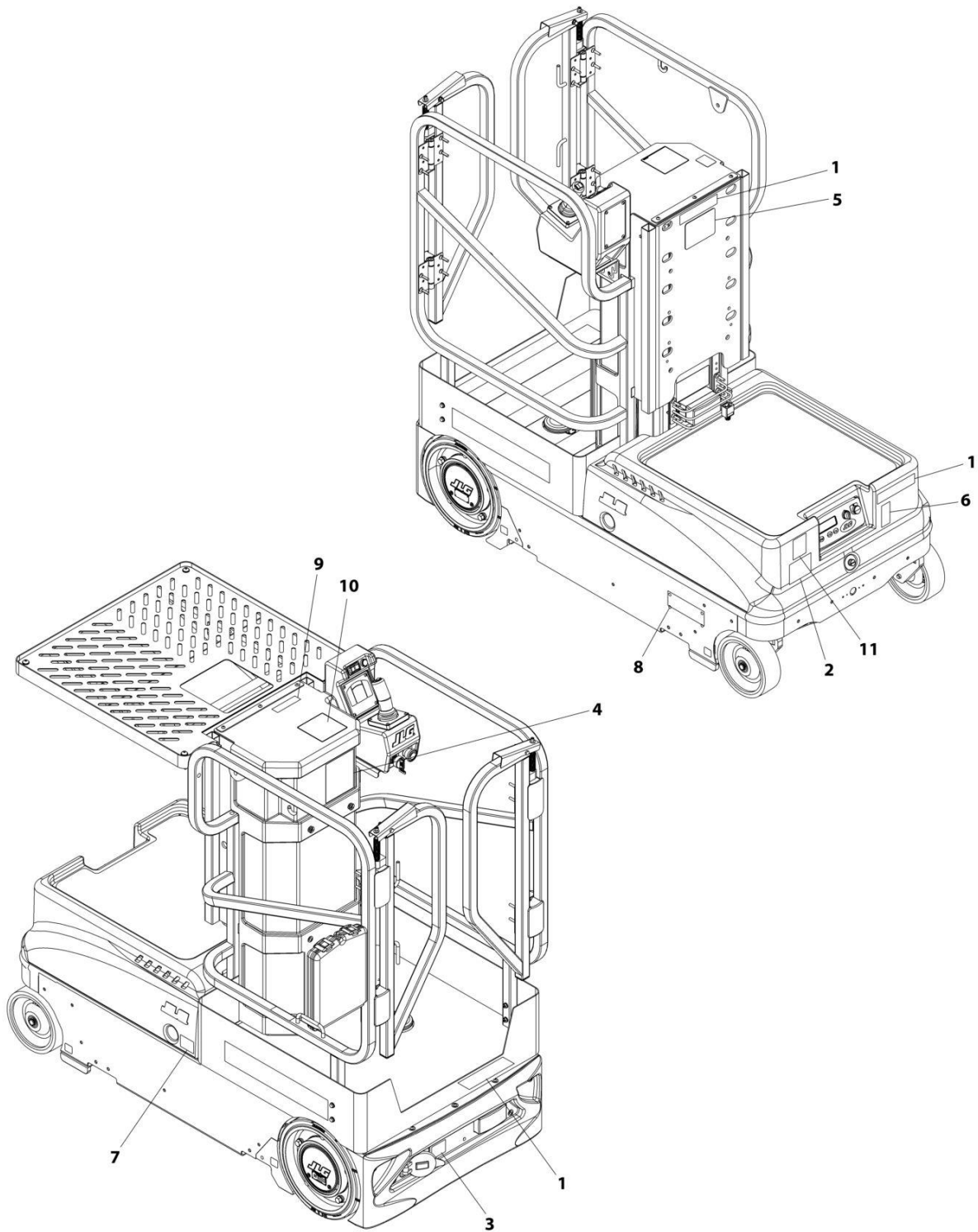

ART_1001254447

SECTION 8 - DECALS

FIGURE 8-10. DECAL INSTALLATION - CE & UK CA SPECS (ENGLISH LANGUAGE) (POWER TRAY)

ITEM	PART NUMBER	QTY	DESCRIPTION	REV
	1001254447	Ref	DECALS INSTALLATION	A
1	1705099	3	Decal - Crushing Hazard	
2	1705802	1	Decal - VP Electrocution	
3	1706077	1	Decal - Battery Charging Instruction	
4	1706078	1	Decal - Warning	
5	1706292	1	Decal - Pinch Point	
6	1706617	1	Decal - No Riders	
7	1706740	1	Decal - Battery Disconnect	
8	2080057	4	Fastener	
9	1001158844	1	Decal - Hand Crushing Hazard	
10	1001202686	1	Decal - Capacity	
11	1001255190	1	Decal - Capacity	

SECTION 8 - DECALS

FIGURE 8-11. DECAL INSTALLATION - CHINA SPECS (CHINESE LANGUAGE) (MANUAL TRAY)

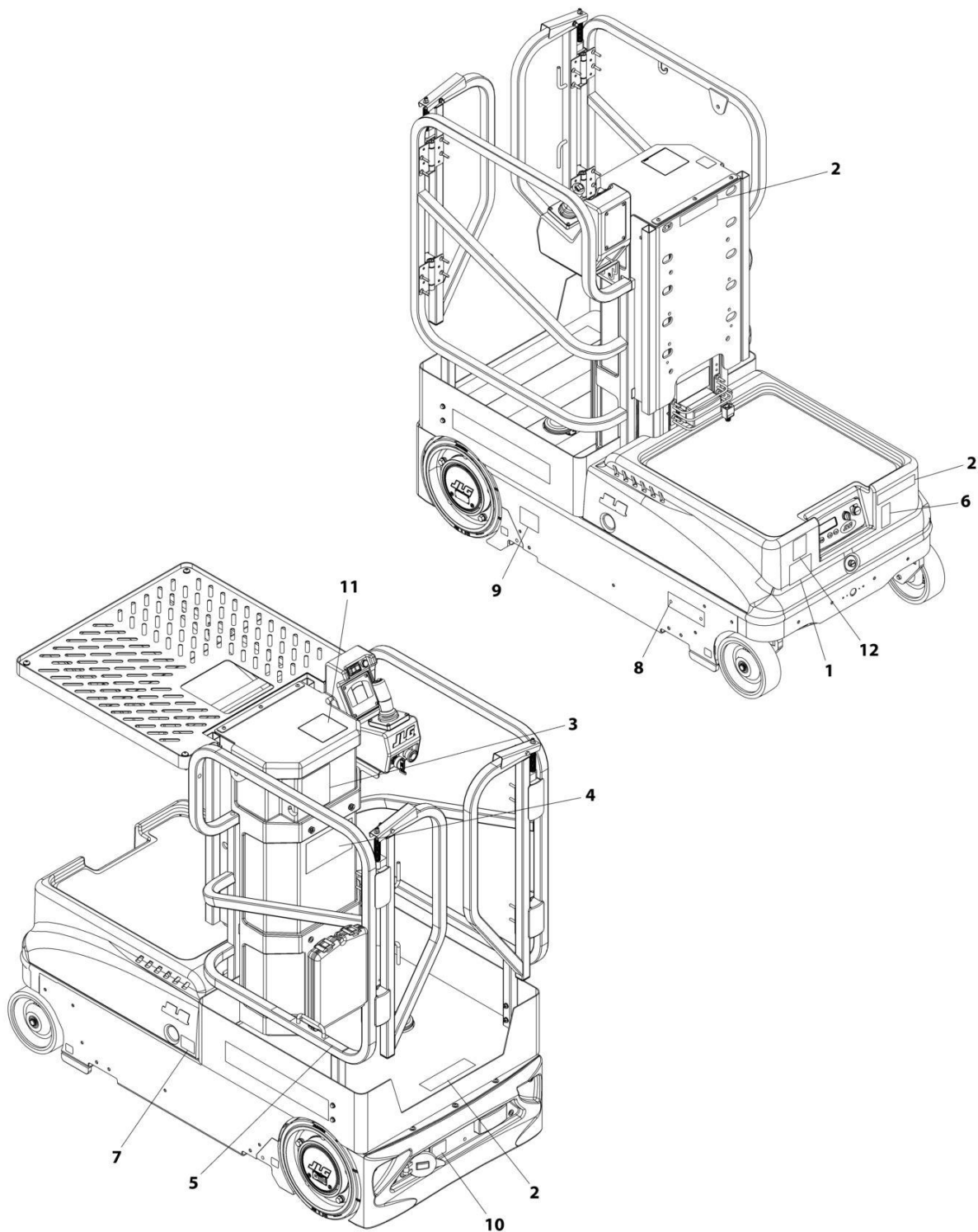

ART_1001254441

SECTION 8 - DECALS

FIGURE 8-11. DECAL INSTALLATION - CHINA SPECS (CHINESE LANGUAGE) (MANUAL TRAY)

ITEM	PART NUMBER	QTY	DESCRIPTION	REV
	1001254441	Ref	DECALS INSTALLATION	A
1	1704077	1	Decal - Electrical Hazard	
2	1706090	3	Decal - Crushing Hazard	
3	1706091	1	Decal - Danger	
4	1706092	1	Decal - Warning	
5	1706117	1	Decal - Fall Restraint	
6	1706617	1	Decal - No Riders	
7	1706740	1	Decal - Battery Disconnect	
8	2080057	2	Fastener	
9	1001224051	1	Decal - Yearly Inspection	
10	1001233058	1	Decal - Battery Charging Instruction	
11	1001254432	1	Decal - Capacity	
12	1001255190	1	Decal - Capacity	

SECTION 8 - DECALS

FIGURE 8-12. DECAL INSTALLATION - CHINA SPECS (CHINESE LANGUAGE) (POWER TRAY)

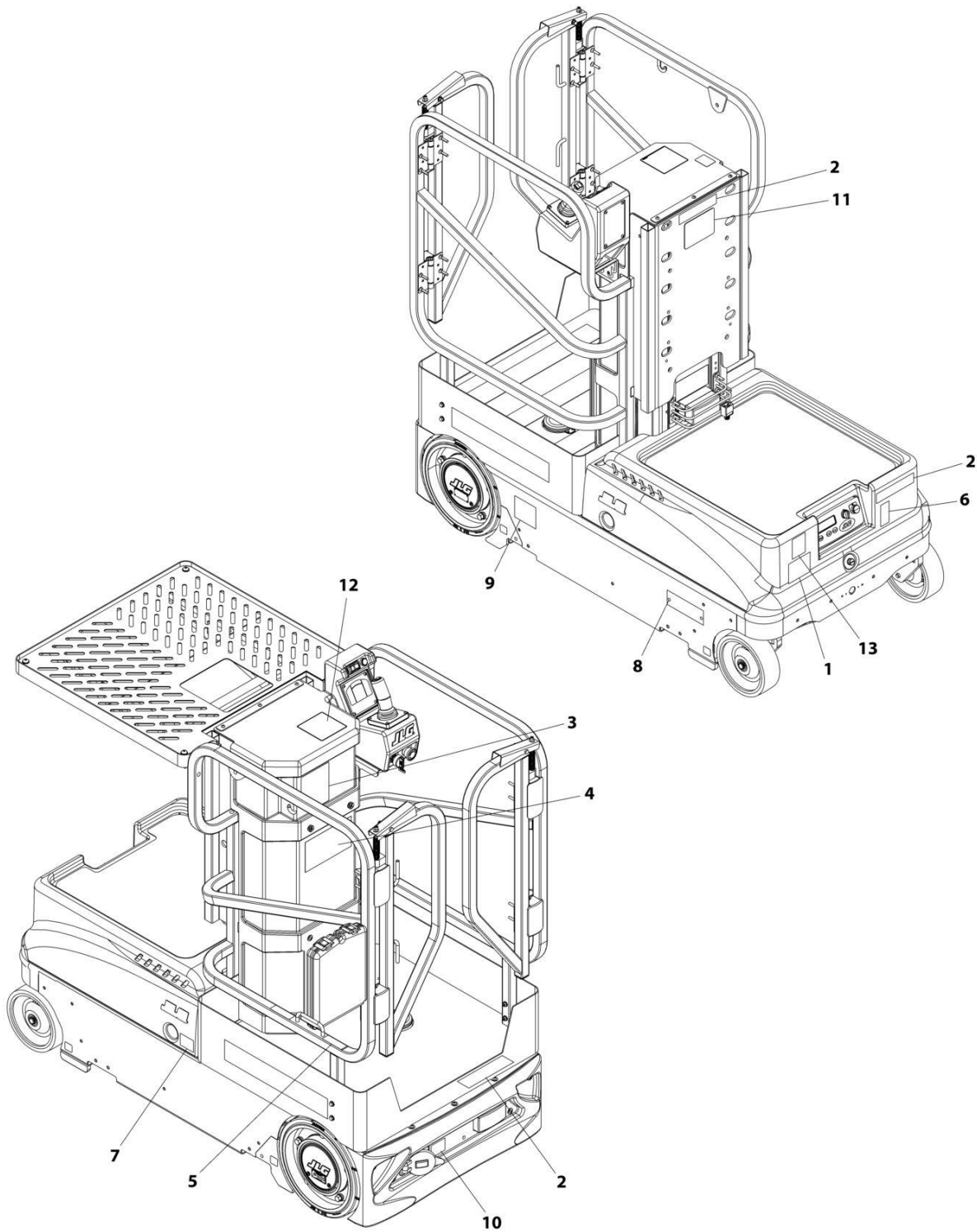

ART_1001254450

SECTION 8 - DECALS

FIGURE 8-12. DECAL INSTALLATION - CHINA SPECS (CHINESE LANGUAGE) (POWER TRAY)

ITEM	PART NUMBER	QTY	DESCRIPTION	REV
	1001254450	Ref	DECALS INSTALLATION	A
1	1704077	1	Decal - Electrical Hazard	
2	1706090	3	Decal - Crushing Hazard	
3	1706091	1	Decal - Danger	
4	1706092	1	Decal - Warning	
5	1706117	1	Decal - Fall Restraint	
6	1706617	1	Decal - No Riders	
7	1706740	1	Decal - Battery Disconnect	
8	2080057	2	Fastener	
9	1001224051	1	Decal - Yearly Inspection	
10	1001233058	1	Decal - Battery Charging Instruction	
11	1001233729	1	Decal - Pinch Point	
12	1001254433	1	Decal - Capacity	
13	1001255190	1	Decal - Capacity	

SECTION 8 - DECALS

FIGURE 8-13. DECAL INSTALLATION - CSA SPECS (FRENCH LANGUAGE) (MANUAL TRAY)

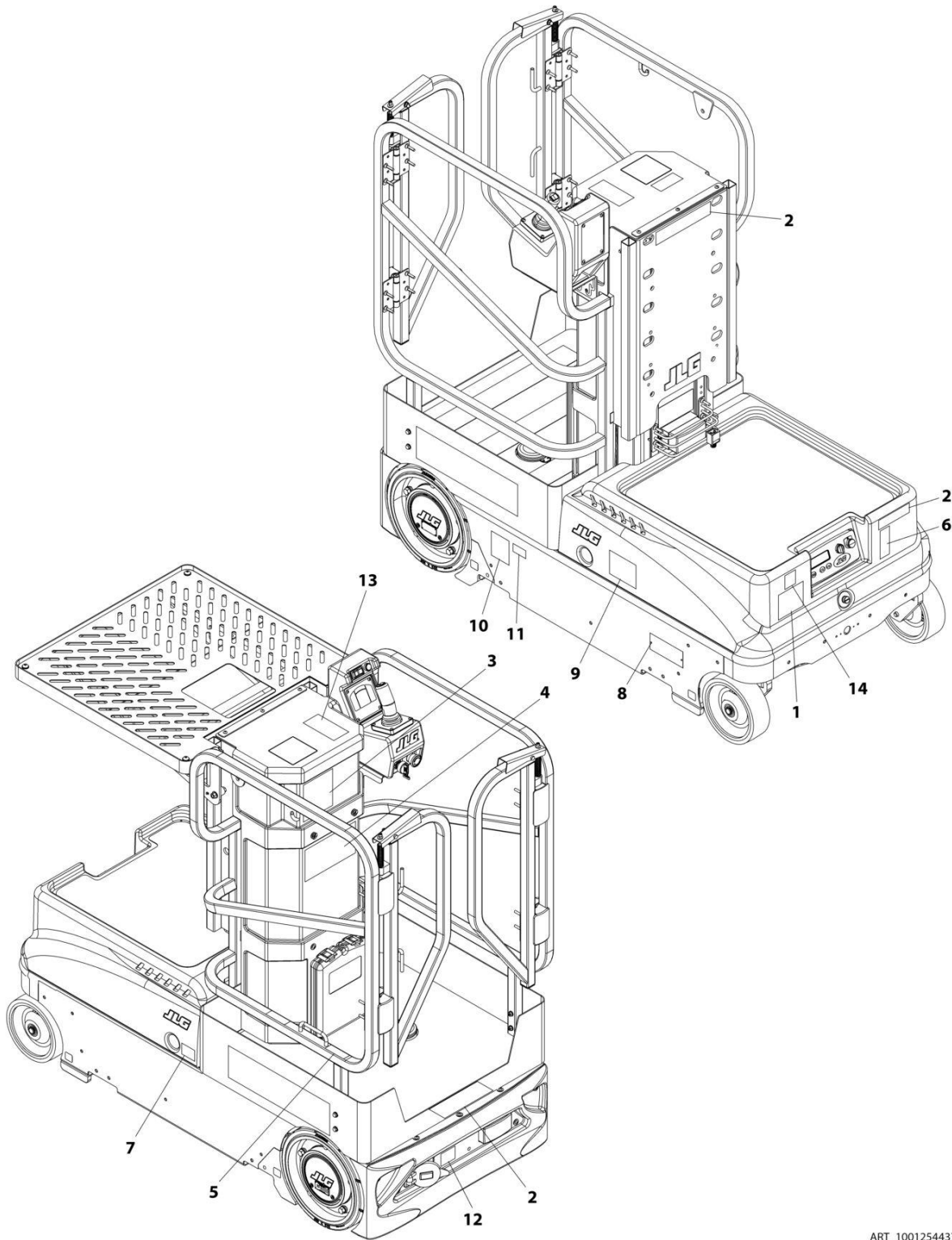

ART_1001254437

SECTION 8 - DECALS

FIGURE 8-13. DECAL INSTALLATION - CSA SPECS (FRENCH LANGUAGE) (MANUAL TRAY)

ITEM	PART NUMBER	QTY	DESCRIPTION	REV
	1001254437	Ref	DECALS INSTALLATION	A
1	1704795	1	Decal - Electrical Hazard	
2	1706094	3	Decal - Crushing Hazard	
3	1706095	1	Decal - Danger	
4	1706096	1	Decal - Warning	
5	1706119	1	Decal - Fall Restraint	
6	1706617	1	Decal - No Riders	
7	1706740	1	Decal - Battery Disconnect	
8	2080057	2	Fastener	
9	1001131273	1	Decal - Patent	
10	1001223971	1	Decal - Yearly Inspection	
11	1001228370	1	Decal - ICES	
12	1001233055	1	Decal - Battery Charging Instruction	
13	1001254432	1	Decal - Capacity	
14	1001255190	1	Decal - Capacity	

SECTION 8 - DECALS

FIGURE 8-14. DECAL INSTALLATION - CSA SPECS (FRENCH LANGUAGE) (POWER TRAY)

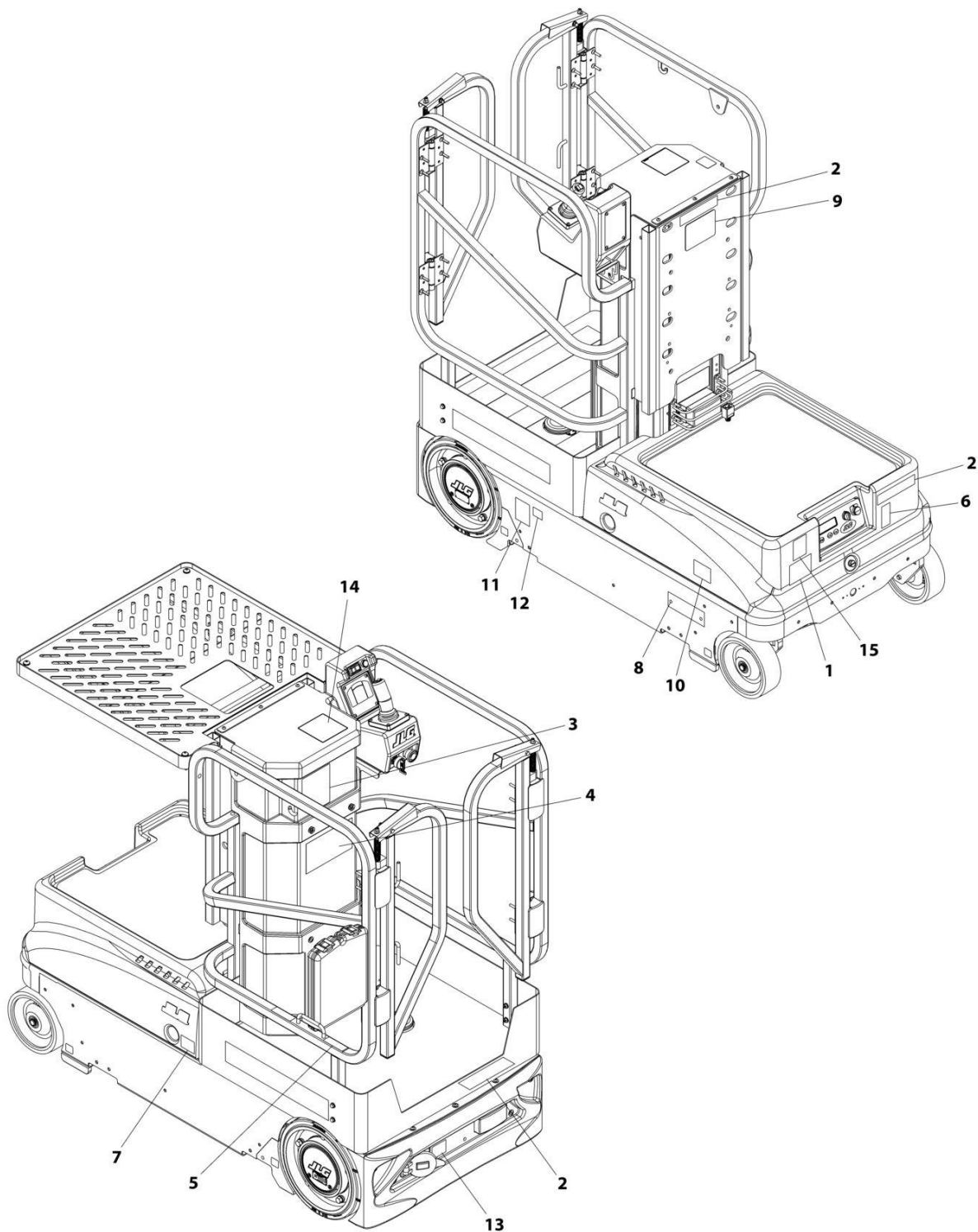

ART_1001254446

SECTION 8 - DECALS

FIGURE 8-14. DECAL INSTALLATION - CSA SPECS (FRENCH LANGUAGE) (POWER TRAY)

ITEM	PART NUMBER	QTY	DESCRIPTION	REV
	1001254446	Ref	DECALS INSTALLATION	A
1	1704795	1	Decal - Electrical Hazard	
2	1706094	3	Decal - Crushing Hazard	
3	1706095	1	Decal - Danger	
4	1706096	1	Decal - Warning	
5	1706119	1	Decal - Fall Restraint	
6	1706617	1	Decal - No Riders	
7	1706740	1	Decal - Battery Disconnect	
8	2080057	2	Fastener	
9	1001093992	1	Decal - Pinch Point	
10	1001131273	1	Decal - Patent	
11	1001223971	1	Decal - Yearly Inspection	
12	1001228370	1	Decal - Canada ICES-001	
13	1001233055	1	Decal - Battery Charging Instruction	
14	1001254433	1	Decal - Capacity	
15	1001255190	1	Decal - Capacity	

SECTION 8 - DECALS

FIGURE 8-15. DECAL INSTALLATION - JAPAN SPECS (JAPANESE LANGUAGE) (MANUAL TRAY)

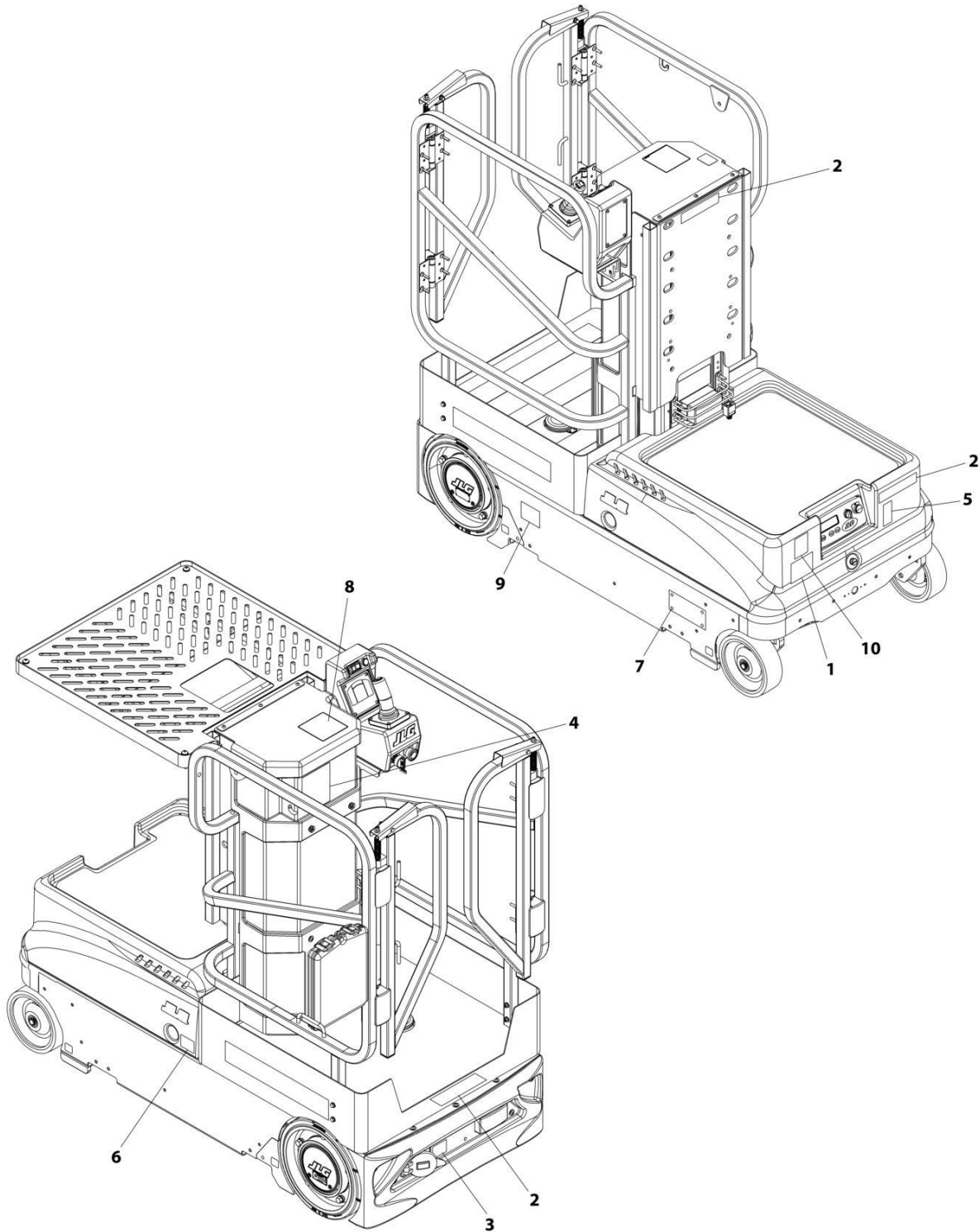

ART_1001254443

SECTION 8 - DECALS

FIGURE 8-15. DECAL INSTALLATION - JAPAN SPECS (JAPANESE LANGUAGE) (MANUAL TRAY)

ITEM	PART NUMBER	QTY	DESCRIPTION	REV
	1001254443	Ref	DECALS INSTALLATION	A
1	1704086	1	Decal - Electrical Hazard	
2	1705099	3	Decal - Crushing Hazard	
3	1706077	1	Decal - Battery Charging Instruction	
4	1706078	1	Decal - Warning	
5	1706617	1	Decal - No Riders	
6	1706740	1	Decal - Battery Disconnect	
7	2080057	4	Fastener	
8	1001207206	1	Decal - Capacity	
9	1001224053	1	Decal - Yearly Inspection	
10	1001255190	1	Decal - Capacity	

SECTION 8 - DECALS

FIGURE 8-16. DECAL INSTALLATION - JAPAN SPECS (JAPANESE LANGUAGE) (POWER TRAY)

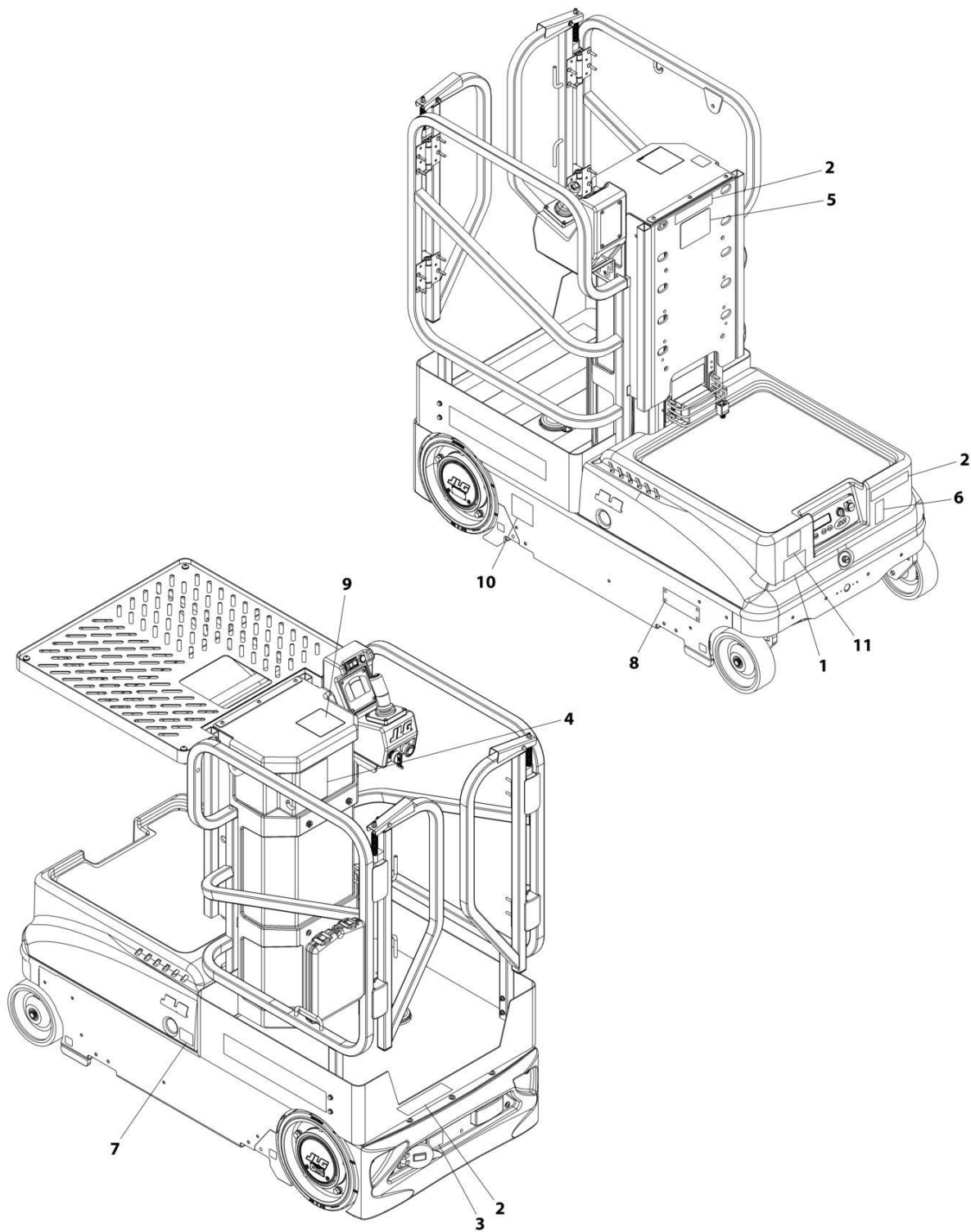

ART_1001254452

SECTION 8 - DECALS

FIGURE 8-16. DECAL INSTALLATION - JAPAN SPECS (JAPANESE LANGUAGE) (POWER TRAY)

ITEM	PART NUMBER	QTY	DESCRIPTION	REV
	1001254452	Ref	DECALS INSTALLATION	A
1	1704086	1	Decal - Electrical Hazard	
2	1705099	3	Decal - Crushing Hazard	
3	1706077	1	Decal - Battery Charging Instruction	
4	1706078	1	Decal - Warning	
5	1706292	1	Decal - Pinch Point	
6	1706617	1	Decal - No Riders	
7	1706740	1	Decal - Battery Disconnect	
8	2080057	4	Fastener	
9	1001202686	1	Decal - Capacity	
10	1001224053	1	Decal - Yearly Inspection	
11	1001255190	1	Decal - Capacity	

SECTION 8 - DECALS

FIGURE 8-17. DECAL INSTALLATION - LATIN AMERICAN SPECS (SPANISH LANGUAGE) (MANUAL TRAY)

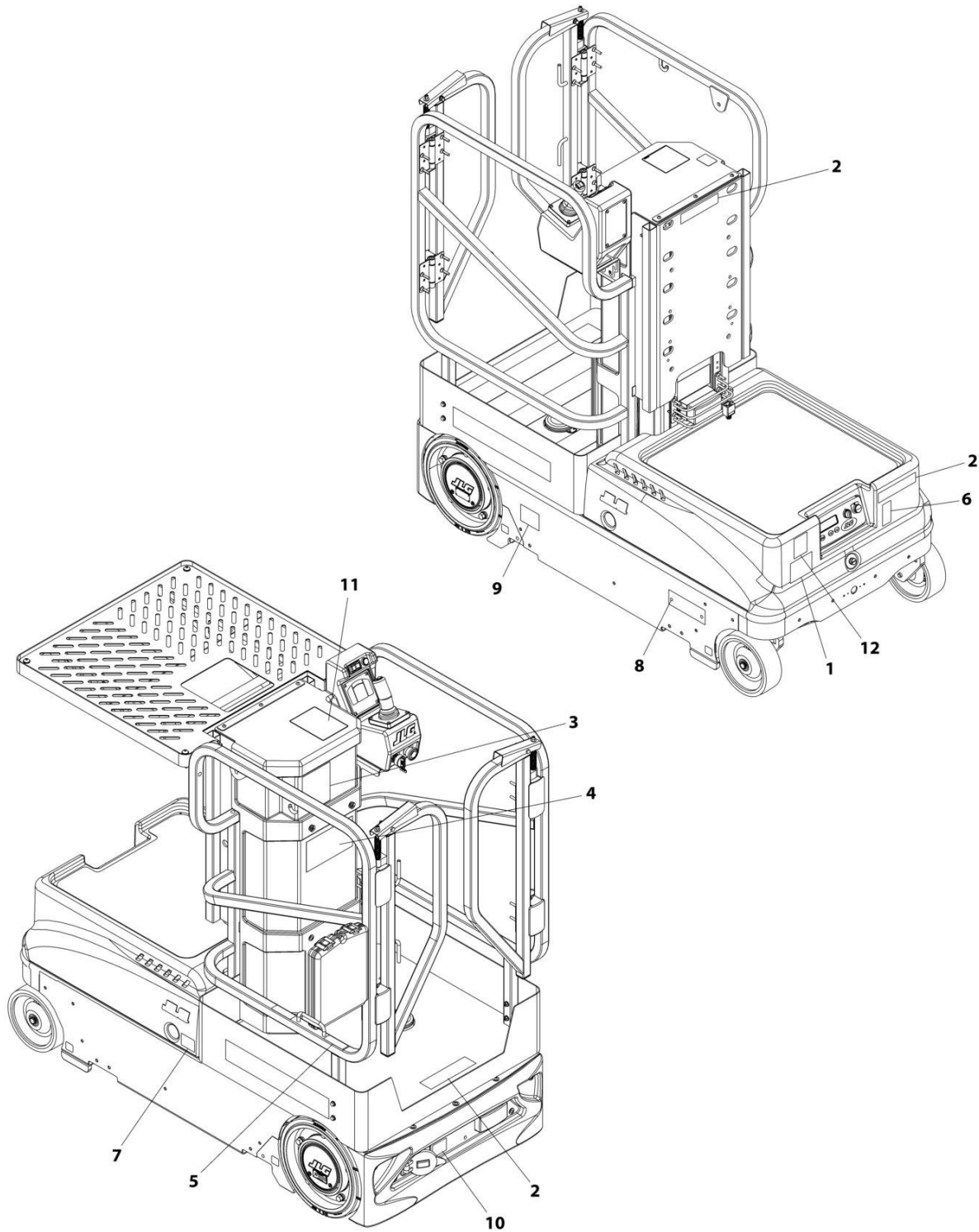

ART_1001254439

SECTION 8 - DECALS

FIGURE 8-17. DECAL INSTALLATION - LATIN AMERICAN SPECS (SPANISH LANGUAGE) (MANUAL TRAY)

ITEM	PART NUMBER	QTY	DESCRIPTION	REV
	1001254439	Ref	DECALS INSTALLATION	A
1	1704029	1	Decal - Electric Hazard	
2	1706082	3	Decal - Crushing Hazard	
3	1706083	1	Decal - Danger	
4	1706084	1	Decal - Warning	
5	1706116	1	Decal - Fall Restraint	
6	1706617	1	Decal - No Riders	
7	1706740	1	Decal - Battery Disconnect	
8	2080057	2	Fastener	
9	1001224049	1	Decal - Yearly Inspection	
10	1001233056	1	Decal - Battery Charging Instruction	
11	1001254432	1	Decal - Capacity	
12	1001255190	1	Decal - Capacity	

SECTION 8 - DECALS

FIGURE 8-18. DECAL INSTALLATION - LATIN AMERICAN SPECS (SPANISH LANGUAGE) (POWER TRAY)

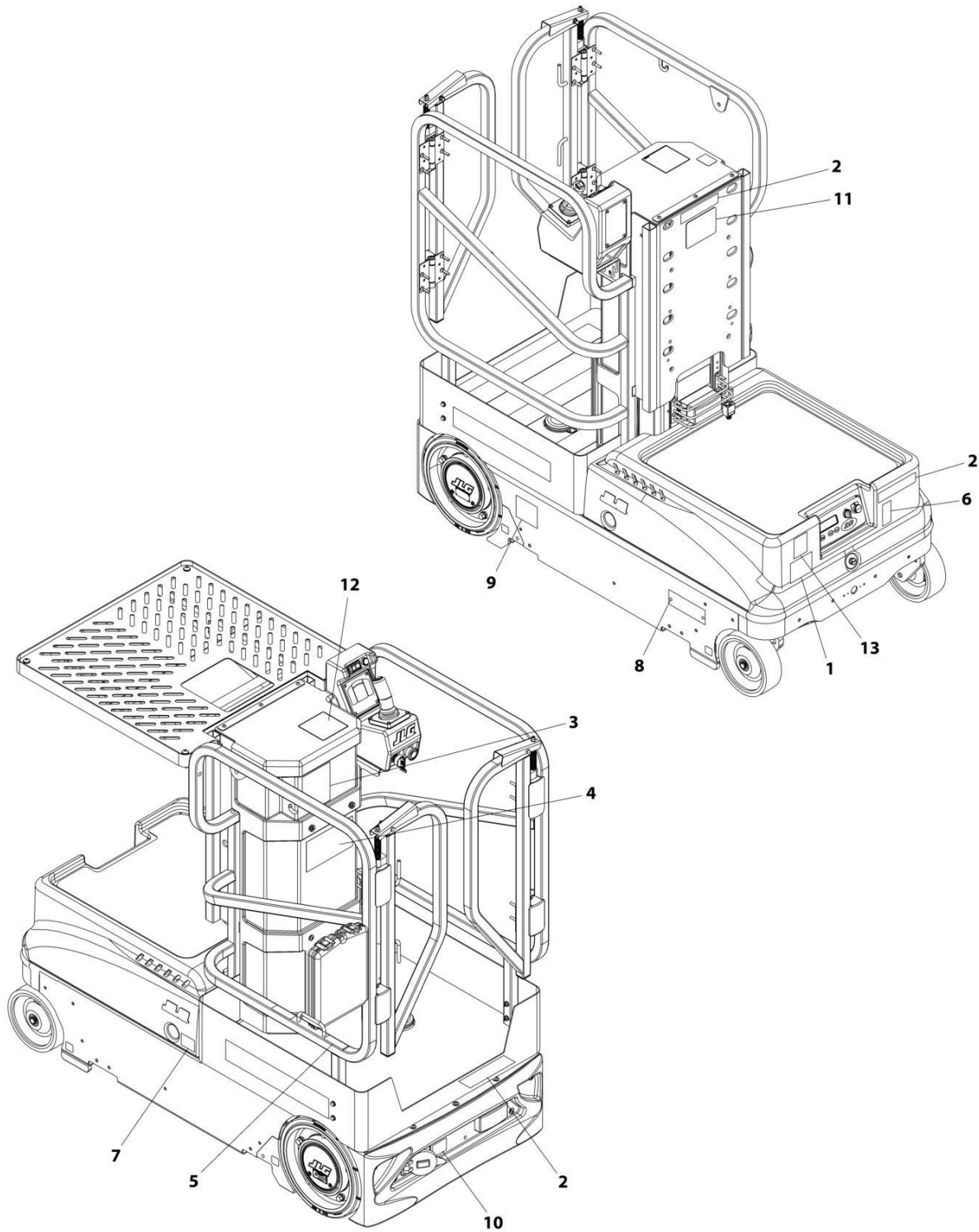

ART_1001254448

SECTION 8 - DECALS

FIGURE 8-18. DECAL INSTALLATION - LATIN AMERICAN SPECS (SPANISH LANGUAGE) (POWER TRAY)

ITEM	PART NUMBER	QTY	DESCRIPTION	REV
	1001254448	Ref	DECALS INSTALLATION	A
1	1704029	1	Decal - Electrical Hazard	
2	1706082	3	Decal - Crushing Hazard	
3	1706083	1	Decal - Danger	
4	1706084	1	Decal - Warning	
5	1706116	1	Decal - Fall Restraint	
6	1706617	1	Decal - No Riders	
7	1706740	1	Decal - Battery Disconnect	
8	2080057	2	Fastener	
9	1001224049	1	Decal - Yearly Inspection	
10	1001233056	1	Decal - Battery Charging Instruction	
11	1001233727	1	Decal - Pinch Point	
12	1001254433	1	Decal - Capacity	
13	1001255190	1	Decal - Capacity	

SECTION 9 - RECOMMENDED SERVICE PARTS STOCK

SECTION 9 - RECOMMENDED SERVICE PARTS STOCK

SECTION 9 - RECOMMENDED SERVICE PARTS STOCK

FIGURE 9-1. RECOMMENDED SERVICE PARTS STOCK

ITEM	PART NUMBER	QTY	DESCRIPTION	REV
		Ref	Note: The following list will service one machine (built to current production per date on the front cover) with emergency repair parts which can be installed in the field. Parts from the list should be replaced when inventory is depleted to keep service parts stock supplied. For further information, contact your JLG dealer or the JLG Industries Parts Department.	
	7011069	1	Breather	
	70006455	1	Coil (Lift Cylinder)	
	1001098192	1	Controller Assembly	
	70007296	12	Filter (Power Tray Pump)	
	2120183	12	Filter, In-Line Pressure	
	2400054	2	Fuse 35Amp (Power Tray Installation)	
	2400069	2	Fuse 175 Amp	
	2860030	1	Key, Replacement	
	1001228458	1	Module, Controller	
	1001255259	1	Module, Ground Control Station (All Specs Except Japanese Specs)	
	1001255260	1	Module, Ground Control Station (Chinese and Japanese Specs)	
	1001231450	1	Module, Traction	
	1001229990	1	Relay (Obstruction Sensing Pad)	
	260269	1	Relay, Inverter (Power Tray Installation)	
	4360514	1	Sensor, Proximity (Batteries, Alarm & Strobe Installation)	
	1001230161	1	Sensor, Proximity (Platform Assembly)	
	1001164530	1	Switch (Power Tray Installation)	
	4360562	1	Switch, Emergency Stop	
	1001229726	1	Switch, Foot	
	4360567	1	Switch, Horn	
	4360467	1	Switch, Key	
	1001208283	1	Switch, Left Hand Control	
	1001210573	1	Switch, Obstruction Pad (Obstruction Sensing Pad)	

SECTION 10 - SPECIAL OPTIONS/ACCESSORIES/KITS

SECTION 10 - SPECIAL OPTIONS/ACCESSORIES/KITS

SECTION 10 - SPECIAL OPTIONS/ACCESSORIES/KITS

FIGURE 10-1. SPECIAL OPTIONS/ACCESSORIES/KITS

ITEM	PART NUMBER	QTY	DESCRIPTION	REV
		Ref	Note: This list is to accommodate machines ordered with special equipment. Options may not be applicable to all models. For more specific parts information contact JLG Parts Department.	
	1001266740	Ref	Beacon Lamp, 10MSP Kit	
	1001266741	Ref	Beacon Lamp, 10MSP Kit	
	1001276923	Ref	ClearSky, GT1030 Kit	
	1001229107	Ref	ClearSky Telematics 3 Wire Installation (Factory Installed) (North American Specs)	
	1001233237	Ref	ClearSky Telematics 3 Wire Installation (Factory Installed) (CE & UK CA Spec)	
	1580029	Ref	Container, Shipping Skid	
		Ref	Decals Installations	
	1001229710	Ref	Decal - Clear Sky	
	1001214031	Ref	Decal - EAC (Russian/CIS Specs)	
	0274568	Ref	Decal - Ground Support Service	
	See Note	NSS	Nameplate - Serial Number (Note: Not Available for Purchase)	
	1001234482	Ref	Obstruction Sensing Pad Kit	
	1001234481	Ref	Power Material Tray Kit	
	1001234483	Ref	Remote Manual Decent Kit	
	1001213967	Ref	Security Lock Installation	
	1001234832	Ref	Service Kit	
	31201384	Ref	Video Operators CD	
	1001262959	Ref	Voltage Regulator ClearSky Locate Kit	

SECTION 10 - SPECIAL OPTIONS/ACCESSORIES/KITS

PART NUMBER INDEX

SECTION 10 - SPECIAL OPTIONS/ACCESSORIES/KITS

0100011.....11, 15, 17, 23, 35, 39, 41, 43, 45, 47, 49, 51, 53, 55, 57, 59, 61, 69, 75, 79, 81, 83, 91, 105, 107, 111, 113	0760810.....85	1001201909.....27	1001228387.....123
0100019.....67, 70, 81	0760814.....85	1001201910.....27	1001228398.....85
0100051.....35, 113	0760818.....27	1001202686.....141, 149, 161	1001228458.....61, 168
0100062.....70	0761014.....85	1001204273.....21	1001228495.....61, 111
0100081.....11	0791003.35, 69, 111, 113	1001204754.....85	1001228538.....15, 17
0140022.....35, 113	0791404.....61	1001204755.....85	1001228539.....15, 17
0140033.....57, 59	0791508.....39	1001204756.....85	1001228540.....15
0240103.....23	0791812.....69	1001204770.....85	1001228541.....15, 17
0240112.....95	0801394.....67, 69	1001204771.....85	1001228543.....15
0240114.....19	0811408.....69	1001204772.....85	1001228835.....61
0273417.....70	0811610.....19, 81	1001204779.....85	1001228847.....81
0273545.....67	0902047.....69	1001204783.....85	1001228848.....83
0273546.....105	0902423.....69	1001204787.....85	1001228849.....11
0274078.....21	0902424.....69	1001204791.....85	1001228850.....11
0274181.....107	0902431.....69	1001205547.....85	1001228852.....15, 17
0274568.....170	0902445.....69	1001205548.....85	1001228853.....83
0274898.....37	0902698.....69	1001205549.....85	1001228854.....81, 83
0274900.....39	0903120.....23	1001205550.....85	1001228873.....79
0362735.....69	0903121.....23	1001205701.....85	1001228874.....79
0440246.....69	0940049.....15, 17	1001205719.....85	1001228875.....75
0440249.....69	0940132.....11	1001205838.....85, 101	1001228876.....75
0440306.....11	0940152.....21	1001206177.....27	1001228994.....25
0440307.....11	1001081050.....111	1001206261.....27	1001229107.....170
0440308.....11	1001091679.....91	1001206460.....111	1001229115.....86
0561149.....70	1001091680.....91	1001206615.....93	1001229116.....86
0561153.....70	1001093992.....157	1001207206.....139, 147, 159	1001229310.....11, 13
0561341.....69	1001097449.....43	1001207339.....111, 119	1001229682.....35
0561408.....70	1001097450.....51	1001207630.....35	1001229683.....35, 113
0561409.....70	1001097451.....53	1001208283.....111, 168	1001229684.....35, 113
0610131.....37, 39	1001097452.....49	1001208602.....85, 89	1001229710.....170
0630464.....61	1001097453.....45	1001210379.....85	1001229725.....27
0630580.....11	1001097454.....47	1001210491.....85, 127	1001229726...75, 79, 168
0641404...35, 57, 59, 113	1001097455.....55	1001210530.....85	1001229778.....15
0641406.....27, 111	1001097456.....41	1001210531.....17	1001229990.....25, 168
0641408.21, 35, 111, 113	1001098192...61, 63, 168	1001210573.....25, 168	1001230062.....133
0641410.....21	1001098193.....61	1001210574.....25	1001230063.....133
0641412.....111	1001098810.....11	1001212654.....125	1001230161...75, 79, 168
0641413.....11	1001099638.....75, 79	1001212655.....125	1001230219.....131, 133
0641414.....11, 95	1001100141.....79	1001212656.....125	1001231257.....85
0641415.....79	1001100142.....79	1001212657.....125	1001231450...57, 59, 168
0641416.....75, 79	1001100634.....79	1001212660.....125	1001231801.....135, 137
0641507.....91	1001101529.....79	1001212661.....125	1001233045.....15
0641606.....23, 105, 107	1001102771.....121	1001213582.....131, 133	1001233046.....17
0641607.....11	1001109821...37, 39, 121	1001213967.....170	1001233054.....135, 137
0641609.....11, 23, 67	1001112143.....111	1001214031.....170	1001233055.....155, 157
0641612.....67	1001114467.....11	1001214996.....119	1001233056.....163, 165
0641613.....81	1001116792.....111	1001215135.....119	1001233057.....143, 145
0641616.....73, 77	1001118156.....117	1001215226.....111, 117	1001233058.....151, 153
0641617.....15, 17, 23	1001121700.....35, 113	1001215633.....119, 123	1001233237.....170
0681414.....75, 79	1001131273.....135, 137, 155, 157	1001215635.....119, 123	1001233727.....165
0700617.....85	1001136381.....37, 39	1001217893.....119	1001233728.....145
0721004.....45, 47, 49, 51, 53, 85	1001143557.....131, 133	1001222318.....93	1001233729.....153
0721006.....69	1001144295.....119	1001223055.....135, 137	1001234322.....15, 17
0721010.....57, 59	1001151629.....123	1001223971.....155, 157	1001234481.....170
0741004.....111	1001153723.....119	1001224049.....163, 165	1001234482.....170
0741005.....35, 113	1001157665.....17	1001224051.....151, 153	1001234483.....170
0741006.....85	1001158844.....149	1001224052.....143, 145	1001234832.....170
0741614.....73, 77	1001164530.....85, 168	1001224053.....159, 161	1001254425.....73
0751003.....75, 79	1001171824.....17	1001225209.....69, 99	1001254426.....73, 75
0760408.....25	1001171856.....83	1001227882.....111, 125	1001254427.....77
0760807.....85	1001171869.....83	1001227884.....61, 123	1001254428.....77, 79
	1001177558.....35	1001228236.....85	1001254432.....135, 143, 151, 155, 163
	1001181407.....81	1001228370.....135, 137, 155, 157	1001254433.....137, 145, 153, 157, 165
	1001187862.....35		1001254436.....135
	1001197889.....117, 119		

SECTION 10 - SPECIAL OPTIONS/ACCESSORIES/KITS

1001254437155	1705802 139, 141, 147, 149	3020039..... 11	390025815, 17
1001254438147	1705937135, 137	3020041 69	3900264111
1001254439163	1705938135, 137	31201384..... 170	390028323
1001254440143	1705992131, 133	3251813..... 135, 137	3900364 85
1001254441151	1705995135, 137	3271405..... 11	3900373111
1001254442139	1706007 61	3271601..... 81	390039383
1001254443159	1706077 139, 141, 147, 149, 159, 161	3290401..... 35, 113	3910408119
1001254445137	1706078 139, 141, 147, 149, 159, 161	3290405..... 25	391060861
1001254446157	1706082163, 165	3290605..... 85	391080461
1001254447149	1706083163, 165	3290801..... 27, 85	3911016 39, 41, 43, 55
1001254448165	1706084163, 165	3290807..... 85	3911432 17
1001254449145	1706086143, 145	3291007..... 83, 85	393101635, 113
1001254450153	1706087143, 145	3300151 79	393141291
1001254451141	1706088143, 145	3300381 79	393142021
1001254452161	1706090151, 153	3300454 15, 17	3931456 79
1001255190 135, 137, 139, 141, 143, 145, 147, 149, 151, 153, 155, 157, 159, 161, 163, 165	1706091151, 153	3310401119	3960590 11
1001255194 75, 79	1706092151, 153	331060161	403150935, 113
1001255259 57, 168	1706094155, 157	331100139, 55	403151135, 113
1001255260 59, 168	1706095155, 157	331100561, 85	403191085
100125526157	1706096155, 157	331140521, 35, 75, 79, 91, 95, 111, 113	4060805 15, 17, 83
100125526259	1706116163, 165	331140869	407086069
1001258016 35, 113	1706117151, 153	331150139, 91	407086169
1001258436 35, 113	1706118143, 145	331160167, 69	407097069
1001262959170	1706119155, 157	331160511, 15, 17, 19, 23, 73, 77, 111	407097169
1001266740170	1706131131, 133	332140227	407108435, 113
1001266741170	1706292 141, 149, 161	334084569	407109575, 79
1001271755 131, 133	1706302137	334096275, 79, 81	407111311
1001271762131	1706617 135, 137, 139, 141, 143, 145, 147, 149, 151, 153, 155, 157, 159, 161, 163, 165	338054061	407111411
1001271763133	1706740 135, 137, 139, 141, 143, 145, 147, 149, 151, 153, 155, 157, 159, 161, 163, 165	342233870	412004639
1001272257113	211060632	342234670	416012469
1001272917 75, 79	2120183 105, 107, 168	342235570	4160130111
1001273307111	2220466 85	342271769	416018721
1001276923170	222059199	342275069	4191706 37, 39, 111
106068937	2221123105, 107	342275269	422030975, 79
1060943 35, 113	222117299	342275769	4240018111
1060944 35, 113	222117399	344041027	4240147 11
1180397119	2221185 32, 105, 107	344041827	430011170
1260375 69, 70	2300014105	345030283	434088461
1260376 69, 70	2300021107	345030470	434100595
127156769	2400044 35, 85, 113	352007275, 79	4341155 11
127156869	240005485, 168	357089369	436046761, 168
127156969	2400069 35, 113, 168	357110170	4360514 35, 113, 168
127157769	260029475, 79	357110370	436056261, 168
1320041111	26026985, 168	357158445, 47, 49, 51, 53	436056761, 168
1320149111	2754025105, 107	358026969	446003575, 79
1380169 15, 17	28001379	358028669	4460226 117, 119, 121
1580029170	286003061, 168	358029369	4460259127
158003195	288031069	3580344111	4460260127
1600466 37, 39	294016583	360039231, 105, 107	4460267119, 125
1701640 131, 133	302002911	368005739	4460268111, 127
1703681 131, 133	3020038 35, 111, 113	3760115 11	4460312119, 127
1703779137		3760308 15, 17	4460320 75, 79, 117, 119, 125
1703781 135, 137		376036519	4460326127
1703786 135, 137		376038369	4460424111, 119
1704021 143, 145		376049611	4460428 45, 47, 49, 51, 53
1704029 163, 165		3820013 35, 113	4460445119
1704077 151, 153		3820032131, 133	4460464115, 125
1704086 159, 161		389003969	4460465119, 121
1704412 105, 107		3900174 15, 17	4460466125
1704795 155, 157		390018769	4460633119
1705099 139, 141, 147, 149, 159, 161		390018961	4460670119
		390019269	4460738 115, 119, 127
		3900200111	4460802 41, 43, 55
		390020575, 79	446080343

SECTION 10 - SPECIAL OPTIONS/ACCESSORIES/KITS

4460829.....	127	4811700.....	85	70007193.....	13	7011016.....	31
4460891.....	119	4811702.....	111	70007194.....	13	7011017.....	31
4460894.....	121	4811900.....	83, 85, 111	70007195.....	13	7011021.....	31
4460897.....	115	4812000.....	83, 85	70007196.....	13	7011024.....	31
4460899.....	125	4891400.....	21	70007197.....	13	7011025.....	31
4460940.....	55	4923022.....	35, 113	70007198.....	13	7011027.....	31
4460961.....	121	4923023.....	35, 113	70007199.....	13	7011029.....	31
4461023.....	119, 123	4923024.....	35, 113	70007200.....	13	7011031.....	31
4461025.....	119	4923028.....	35, 113	70007201.....	13	7011032.....	31
4461108.....	115	4923029.....	35, 113	70007202.....	13	7011033.....	31
4461196.....	45	4923107.....	61	70007203.....	13	7011034.....	31
4461199.....	47	4923108.....	61	70007204.....	13	7011069.....	31, 168
4461205.....	51, 53	4923174.....	43	70007205.....	13	7023391.....	99
4461249.....	49	4923383.....	35, 113, 115	70007206.....	13	7023392.....	99
4520342.....	11	4923438.....	37, 39	70007207.....	13	7023395.....	99
4520343.....	11	4923446.....	35, 113	70007292.....	89	7024747.....	13
4520352.....	23	70000082.....	63	70007293.....	89	7024748.....	13
4567491.....	69	70000084.....	63	70007294.....	89	7024756.....	13
4567750.....	69	70000218.....	99	70007295.....	89	7024758.....	13
4567751.....	69	70000683.....	63	70007296.....	89, 168	7024786.....	13
4569003.....	70	70000684.....	63	70007297.....	89	7027247.....	99
4711000.....	45, 47, 49, 51, 53, 85, 111	70000685.....	63	70007298.....	89	7027365.....	63
4711400.....	11, 27, 70, 75, 79, 91, 111	70000686.....	63	70007299.....	89	7027367.....	63
4711500.....	70	70000991.....	99	70007300.....	89	7027765.....	63
4711600.....	11, 15, 17, 19, 67, 73, 77, 81, 83	70000992.....	99	70007301.....	89	7027766.....	63
4740007.....	70	70000993.....	99	70007302.....	89	7027943.....	31
4740139.....	15, 17	70000995.....	99	70007303.....	89	7027944.....	31
4740414.....	70	70001250.....	63	70007304.....	89	7027945.....	31
4751000.....	57, 59	70001251.....	63	70007305.....	89	7027946.....	31
4751200.....	111	70001252.....	63	70007306.....	89	7027947.....	31
4751400.....	15, 17, 21, 35, 113	70001253.....	63	70022700.....	101	7027948.....	31
4751500.....	39, 70, 91	70006451.....	99	70022703.....	101	7027949.....	31
4760400.....	119	70006453.....	99	70022704.....	101	8220904.....	127
4761000.....	55	70006454.....	99	70022705.....	101	8305919.....	85
4761400.....	70, 111	70006455.....	99, 168	7010928.....	31	8406112.....	111
4811400.....	25, 35, 113	70006456.....	101	7011004.....	31	8882320.....	93
		70006457.....	101	7011008.....	31	8882970.....	11
		70007190.....	13	7011009.....	31	8990147.....	131, 133
		70007191.....	13	7011011.....	31		
		70007192.....	13	7011013.....	31		



An Oshkosh Corporation Company

Corporate Office
JLG Industries, Inc.
1 JLG Drive
McConnellsburg, PA 17233-9533 USA
☎ (717) 485-5161 (Corporate)
☎ (877) 554-5438 (Customer Support)
📠 (717) 485-6417

Visit our website for JLG Worldwide Locations.
www.jlg.com