



---

***Operators and Safety Manual  
Service & Maintenance Manual  
Illustrated Parts Manual***

**Models  
CM1432  
CM1432 PLUS  
CM1732  
CM2033  
CM2046  
CM2546  
CM2558**

**3120809**  
October 2, 1995



## FOREWORD

The purpose of this manual is to provide the customer with the operating procedures essential for the promotion of proper machine operation for its intended purpose. It is important to over-stress proper usage. All information in this manual should be READ and UNDERSTOOD before any attempt is made to operate the machine. YOUR OPERATING MANUAL IS YOUR MOST IMPORTANT TOOL - Keep it with the machine.

**SINCE THE MANUFACTURER HAS NO DIRECT CONTROL OVER MACHINE APPLICATION AND OPERATION, CONFORMANCE WITH GOOD SAFETY PRACTICE IN THIS AREA IS THE RESPONSIBILITY OF THE USER AND HIS OPERATING PERSONNEL.**

**ALL PROCEDURES HEREIN ARE BASED ON THE USE OF THE MACHINE UNDER PROPER OPERATING CONDITIONS, WITH NO DEVIATIONS FROM THE ORIGINAL DESIGN. ALTERATION AND/OR MODIFICATION OF THE MACHINE IS STRICTLY FORBIDDEN WITHOUT WRITTEN APPROVAL FROM JLG INDUSTRIES, INC.**

**A MOST IMPORTANT FACT TO REMEMBER IS THAT ANY EQUIPMENT IS ONLY AS SAFE AS THOSE WHO OPERATE IT.**

### **DANGER, WARNING, CAUTION, IMPORTANT, INSTRUCTIONS AND NOTE DEFINITIONS**

Since safety of personnel and proper use of the machine are of primary concern, DANGER, WARNING, CAUTION, IMPORTANT, INSTRUCTIONS and NOTES are inserted throughout this manual to emphasize these areas. They are defined as follows:

#### **DANGER**

**IF NOT CORRECTLY FOLLOWED THERE IS A HIGH PROBABILITY OF SERIOUS INJURY OR DEATH TO PERSONNEL.**

#### **WARNING or CAUTION**

**IF NOT CORRECTLY FOLLOWED THERE IS SOME POSSIBILITY OF SERIOUS INJURY OR DEATH TO PERSONNEL.**



**THE "SAFETY ALERT SYMBOL" IS USED TO CALL ATTENTION TO POTENTIAL HAZARDS WHICH MAY LEAD TO DEATH OR SERIOUS INJURY IF IGNORED.**

#### **IMPORTANT OR INSTRUCTIONS**

**DENOTES PROCEDURES ESSENTIAL TO SAFE OPERATION AND PREVENTION OF DAMAGE TO OR DESTRUCTION OF MACHINE.**

#### **Note**

**Provides information of special interest to illustrate the text.**

All procedures herein are based on the use of the machine under proper operating conditions, with no deviations from original design intent ... as per OSHA regulations.

## READ & HEED!

The ownership, use, service, and/or maintenance of this machine is subject to various federal, state and local laws and regulations. It is the responsibility of the owner/user to be knowledgeable of these laws and regulations and to comply with them. The most prevalent regulations of this type are the Federal OSHA Safety Regulations\*. Listed below, in abbreviated form are some of the requirements of Federal OSHA regulations in effect as of the date of publication of this handbook.

The listing of these requirements shall not relieve the owner/user of the responsibility and obligation to determine all applicable laws and regulations and their exact wording and requirements, and to comply with the requirements. Nor shall the listing of these requirements constitute an assumption of responsibility of liability on the part of JLG Industries, Inc.

1. Only trained and authorized operators shall be permitted to operate the aerial lift.
2. A malfunctioning lift shall be shut down until repaired.
3. The controls shall be plainly marked as to their function.
4. The controls shall be tested each day prior to use to determine that they are in safe operating condition.
5. All personnel in the platform shall wear an approved safety belt with the lanyard attached to the platform attachment point.
6. Load limits specified by the manufacturer shall not be exceeded.
7. Instruction and warning placards must be legible.
8. Aerial lifts may be "field modified" for uses other than those intended by the manufacturer or an equivalent entity, such as a nationally recognized testing lab, to be in conformity to applicable OSHA safety regulations and to be at least as safe as it was prior to modification.
9. Aerial lifts shall not be used near electric power lines unless the lines have been deenergized or adequate clearance is maintained (see OSHA 20 CFR 1910.67 and 1926.400).
10. Employees using aerial lifts shall be instructed how to recognize and avoid unsafe conditions and hazards.
11. Ground controls shall not be operated unless permission has been obtained from personnel in the platform, except in case of an emergency.
12. Regular inspection of the job site and aerial lift shall be performed by competent persons.
13. Personnel shall always stand on the floor of the platform, not on boxes, planks, railing or other devices for a work position.

\*Applicable Federal OSHA regulations, as of the date of publication of this manual include, but are not limited to, 29 CFR 1910.67, 29 CFR 1926.20, 29 CFR 1926.21, 29 CFR 1926.28, 29 CFR 1926.400 and 29 CFR 1926.556. Consult the current regulations for the exact wording and full text of the requirements and contact the closest Federal OSHA office for specific interpretations.

**A. GENERAL.**

1. This section contains the general safety precautions which must be observed during maintenance of the aerial platform. It is of utmost importance that maintenance personnel pay strict attention to these warnings and precautions to avoid possible injury to themselves or others or damage to the equipment. A maintenance program must be established by a qualified person and must be followed to ensure that the machine is safe to operate.

**WARNING**

**MODIFICATION OF THE MACHINE WITHOUT CERTIFICATION BY A RESPONSIBLE AUTHORITY THAT THE MACHINE IS AT LEAST AS SAFE AS ORIGINALLY MANUFACTURED IS A SAFETY VIOLATION.**

2. The specific precautions to be observed during machine maintenance are inserted at the appropriate point in the manual. These precautions are, for the most part, those that apply when servicing hydraulic and larger machine component parts.
3. Your safety, and that of others, is the first consideration when engaging in the maintenance of equipment. Always be conscious of weight.

Never attempt to move heavy parts without the aid of a mechanical device. Do not allow heavy objects to rest in an unstable position. When raising a portion of the equipment, ensure that adequate support is provided.

**WARNING**

**SINCE THE MACHINE MANUFACTURER HAS NO DIRECT CONTROL OVER THE FIELD INSPECTION AND MAINTENANCE, SAFETY IN THIS AREA IS THE RESPONSIBILITY OF THE OWNER/OPERATOR.**

**B. HYDRAULIC SYSTEM SAFETY.**

1. It should be particularly noted that the machines hydraulic systems operate at extremely high and potentially dangerous pressures. Every effort should be made to relieve any system pressure prior to disconnecting or removing any portion of the system.

2. Relieve system pressure by cycling the applicable control several times with the engine stopped and ignition on, to direct any line pressure back into the return line to the reservoir. Pressure feed lines to system components can then be disconnected with minimal fluid loss.

**C. MAINTENANCE.****WARNING**

**FAILURE TO COMPLY WITH SAFETY PRECAUTIONS LISTED IN THIS SECTION MAY RESULT IN MACHINE DAMAGE, PERSONNEL INJURY OR DEATH AND IS A SAFETY VIOLATION.**

REMOVE ALL RINGS, WATCHES, AND JEWELRY WHEN PERFORMING ANY MAINTENANCE.

DO NOT WEAR LONG HAIR UNRESTRAINED, OR LOOSE FITTING CLOTHING AND NECKTIES WHICH ARE APT TO BECOME CAUGHT ON OR ENTANGLED IN EQUIPMENT.

OBSERVE AND OBEY ALL WARNINGS AND CAUTIONS ON MACHINE AND IN SERVICE MANUAL.

KEEP OIL, GREASE, WATER, ETC. WIPED FROM STANDING SURFACES AND HAND HOLDS.

NEVER WORK UNDER AN ELEVATED PLATFORM UNTIL SAFETY PROPS HAVE BEEN ENGAGED OR PLATFORM HAS BEEN SAFELY RESTRAINED FROM ANY MOVEMENT BY BLOCKING OR OVERHEAD SLING.

BEFORE MAKING ADJUSTMENTS, LUBRICATING OR PERFORMING ANY OTHER MAINTENANCE, SHUT OFF ALL POWER CONTROLS.

BATTERY SHOULD ALWAYS BE DISCONNECTED DURING REPLACEMENT OF ELECTRICAL COMPONENTS.

KEEP ALL SUPPORT EQUIPMENT AND ATTACHMENTS STOWED IN THEIR PROPER PLACE.

USE ONLY APPROVED, NONFLAMMABLE CLEANING SOLVENTS.

# EURO CM1432-CM2558 3120809 PARTS MANUAL REVISION LOG

---

June 1991 - Original Issue

January 1993 - Revised (Added CM1432)

March 1993 - Revised (Added CM1432+ and CM1732)

October 1994 - Revised

December 1994 - Change 1

Pages Affected:

Cover

Table of Contents Page iv

Revision Log - Page c

Section 10 - Pages 10-1 and 10-2

Section 11 - Table of Contents - Page 11-0-1

Section 11-1 - Pages 11-1-5, 11-1-6, 11-1-7, 11-1-17 and 11-1-18

Section 11-2 - Pages 11-2-4, 11-2-6, 11-2-13, 11-2-17, 11-2-24 to 11-2-27

Section 11-3 - Pages 11-3-1, 11-3-11, 11-3-13 to 11-3-15

Section 11-4 - Pages 11-4-3 to 11-4-5, 11-4-7, 11-4-13, 11-4-15, 11-4-17, 11-4-19, 11-4-23,  
11-4-25 and 11-4-26

Section 11-6 - Pages 11-6-3, 11-6-5, 11-6-7 and 11-6-8

Section 11-7 - Pages 11-7-1, 11-7-3, 11-7-6, 11-7-7, 11-7-15, 11-7-17 to 11-7-22

Section 11-8 - Pages 11-8-3 to 11-8-6

Section 12 - Pages 12-1 and 12-2

Section 13 - Table of Contents - Page 13-0-1

Section 13-1 - Pages 13-1-3, 13-1-9, 13-1-10, 13-1-12 to 13-1-14

Section 13-2 - Pages 13-2-7 and 13-2-11

Section 13-3 - Pages 13-3-7, 13-3-9 to 13-3-11

Section 13-4 - Pages 13-4-1, 13-4-4, 13-4-5, 13-4-7, 13-4-7A, 13-4-7B, 13-4-8, 13-4-9,  
13-4-9A, 13-4-9B, 13-4-13, 13-4-15 and 13-4-17

Section 13-6 - Page 13-6-4

Section 13-7 - Pages 13-7-1, 13-7-5 and 13-7-13 to 13-7-18

October 1995 - Change 2

Pages Affected:

Cover

Revision Log - Page c

Table of Contents - Page iv and v

Section 11 - Table of Contents - Pages 11-0-1 and 11-0-2

Section 11-1 - Pages 11-1-3 to 11-1-7, 11-1-11 and 11-1-15 to 11-1-19

Section 11-2 - Pages 11-2-5, 11-2-7, 11-2-9 to 11-2-11, 11-2-15, 11-2-19, 11-2-24 to 11-2-25B  
and 11-2-27

Section 11-3 - Pages 11-3-1, 11-3-3, 11-3-4, 11-3-7, 11-3-9 and 11-3-13 to 11-3-18

Section 11-4 - Pages 11-4-5, 11-4-7, 11-4-13, 11-4-17 and 11-4-24 to 11-4-27

Section 11-5 - Page 11-5-11

Section 11-6 - Pages 11-6-5 and 11-6-8

Section 11-7 - Pages 11-7-1 to 11-7-19

Section 11-8 - Pages 11-8-2 to 11-8-4 and 11-8-6

Section 13 - Table of Contents - Page 13-0-1

Section 13-1 - Pages 13-1-3, 13-1-7 to 13-1-11, 13-1-15 and 13-1-17

Section 13-2 - Pages 13-2-5 and 13-3-12

Section 13-3 - Pages 13-3-1 to 13-3-5, 13-3-7, 13-3-9 to 13-3-14

Section 13-4 - Pages 13-4-3 to 13-4-5, 13-4-7, 13-4-9, 13-4-15 and 13-4-16

Section 13-5 - Page 13-5-9

Section 13-7 - Pages 13-7-2 to 13-7-15

Section 13-8 - Pages 13-8-2, 13-9-5, 13-8-7 and 13-8-8

Change 2 c/d Blank



## TABLE OF CONTENTS

SUBJECT - SECTION, PARAGRAPH	PAGE NO.
INTRODUCTION - OPERATION SAFETY PRECAUTIONS .....	a
INTRODUCTION - MAINTENANCE SAFETY PRECAUTIONS .....	b
EURO CM1432-CM2558 3120809 PARTS MANUAL REVISION LOG .....	c
TABLE OF CONTENTS .....	i
LIST OF ILLUSTRATIONS .....	iii
LIST OF TABLES .....	v
 <b>SECTION 1 — SAFETY PRECAUTIONS</b>	
1-1. General .....	1-1
1-2. Driving/Towing/Carrying .....	1-1
1-3. Electrocution Hazard .....	1-2
1-4. Pre-Operational .....	1-3
1-5. Driving .....	1-4
1-6. Operation .....	1-5
1-7. Towing and Hauling .....	1-9
1-8. Maintenance .....	1-10
 <b>SECTION 2 — PREPARATION AND INSPECTION</b>	
2-1. General .....	2-1
2-2. Preparation For Use .....	2-1
2-3. Delivery and Periodic Inspection .....	2-1
2-4. Daily Walk-Around Inspection .....	2-2
2-5. Daily Functional Check .....	2-2
2-6. Torque Requirements .....	2-3
2-7. Battery Charging .....	2-3
 <b>SECTION 3 — USER RESPONSIBILITIES AND MACHINE CONTROL</b>	
3-1. General .....	3-1
3-2. Personnel Training .....	3-1
3-3. Operating Characteristics and Limitations .....	3-1
3-4. Controls and Indicators .....	3-2
 <b>SECTION 4 — MACHINE OPERATION</b>	
4-1. Description .....	4-1
4-2. General .....	4-1
4-3. Motor Operation .....	4-1
4-4. Raising and Lowering (Lifting) .....	4-2
4-5. Platform Extension (If Equipped) .....	4-2
4-6. Steering .....	4-3
4-7. Traveling (Driving) .....	4-3
4-8. Parking and Stowing .....	4-4
4-9. Platform Loading .....	4-4
4-10. Safety Prop .....	4-5
4-11. Tie Down and Lifting .....	4-5
4-12. Towing .....	4-5
 <b>SECTION 5 — OPTIONAL EQUIPMENT</b>	
5-1. PQ Controller .....	5-1
5-2. Platform Extension .....	5-1
5-3. Horn .....	5-1
5-4. Travel Alarm .....	5-1
5-5. Motion Alarm .....	5-1

## TABLE OF CONTENTS (cont.)

SUBJECT-SECTION, PARAGRAPH	PAGE NO.
<b>SECTION 5 — OPTIONAL EQUIPMENT (cont.)</b>	
5-6. Descent Alarm .....	5-1
5-7. Platform Work Lights .....	5-1
5-8. Foam Filled Tires (CM2046 and CM2558 Only) .....	5-1
5-9. Non-Marking Tires .....	5-1
5-10. Rotating Beacon .....	5-1
5-11. High Output Batteries (CM2046, CM2546 and CM2558 Only) .....	5-1
5-12. Battery Condition Indicator .....	5-1
5-13. Fold-Down Hand Rails .....	5-1
5-14. Control Box Cover (Standard Toggle Switch Controls Only) .....	5-1
5-15. Lifting Lugs .....	5-1
5-16. Platform Access Door .....	5-1
<b>SECTION 6 — EMERGENCY PROCEDURES</b>	
6-1. General .....	6-1
6-2. Emergency Towing Procedures .....	6-1
6-3. Emergency Controls and Their Locations .....	6-1
6-4. Emergency Operation .....	6-2
6-5. Incident Notification .....	6-2
<b>SECTION 7 — SPECIFICATIONS</b>	
7-1. Capacities .....	7-1
7-2. Component Data .....	7-1
7-3. Performance Data .....	7-1
7-4. Torque Requirements .....	7-2
7-5. Lubrication .....	7-2
7-6. Pressure Settings .....	7-2
7-7. Cylinder Specifications .....	7-6
7-8. Serial Number Locations .....	7-6
7-9. Limit Switches .....	7-6
7-10. Major Component Weights .....	7-9
7-11. Critical Stability Weights .....	7-9
<b>SECTION 8 — PROCEDURES</b>	
8-1. General .....	8-1
8-2. Servicing and Maintenance Guidelines .....	8-1
8-3. Lubrication Information .....	8-2
8-4. Cylinders - Theory of Operation .....	8-3
8-5. Valves - Theory of Operation .....	8-3
8-6. Component Functional Description .....	8-4
8-7. Wear Pads .....	8-4
8-8. Cylinder Checking Procedures .....	8-5
8-9. Cylinder Removal and Installation .....	8-5
8-10. Cylinder Repair (Except Brake Cylinder) .....	8-6
8-11. Brake Cylinder Repair .....	8-8
8-12. Tilt Alarm Switch .....	8-10
8-13. Limit Switch Adjustments .....	8-11
8-14. Pressure Setting Procedures .....	8-12
8-15. Preventive Maintenance and Inspection Schedule .....	8-14
<b>SECTION 9 — TROUBLESHOOTING</b>	
9-1. General .....	9-1
9-2. Troubleshooting Information .....	9-1
9-3. Hydraulic Circuit Checks .....	9-1



## TABLE OF CONTENTS (cont.)

SUBJECT-SECTION, PARAGRAPH	PAGE NO.
SECTION 10 — RECOMMENDED SPARE PARTS LIST - CM2033/CM2046/CM2546/CM2558	
Recommended Spare Parts List . . . . .	10-1
SECTION 11 — ILLUSTRATED PARTS LIST - CM2033/CM2046/CM2546/CM2558	
Table of Contents. . . . .	11-0-1
SECTION 12 — RECOMMENDED SPARE PARTS LIST - CM1432/CM1432 PLUS/CM1732	
Recommended Spare Parts List . . . . .	12-1
SECTION 13 — ILLUSTRATED PARTS LIST - CM1432/CM1432 PLUS/CM1732	
Table of Contents. . . . .	13-0-1

## LIST OF ILLUSTRATIONS

FIGURE NO.	TITLE	PAGE NO.
2-1	Daily Walk-Around Inspection - CM1432/CM1432 Plus/CM1732 . . . . .	2-4
2-2	Daily Walk-Around Inspection - CM2033/CM2046/CM2546/CM2558 . . . . .	2-6
3-1	Ground Control Station - CM1432/CM1432 Plus/CM1732 . . . . .	3-4
3-2	Ground Control Station - CM2033/CM2046/CM2546/CM2558 . . . . .	3-4
3-3	Platform Control Station w/o PQ Controller - All Models (Machines Built Before August 1992) . . . . .	3-5
3-4	Platform Control Station w/PQ Controller - All Models (Machines Built Before August 1992) . . . . .	3-5
3-5	Platform Control Station w/o PQ Controller - All Models (Machines Built After August 1992) . . . . .	3-6
3-6	Platform Control Station w/PQ Controller - All Models (Machines Built After August 1992) . . . . .	3-6
4-1	Grade and Sideslope . . . . .	4-3
7-1	Torque Chart . . . . .	7-3
7-2	Lubrication Chart - CM1432/CM1432 Plus/CM1732 . . . . .	7-4
7-3	Lubrication Chart - CM2033/CM2046/CM2546/CM2558 . . . . .	7-5
7-4	Serial Number Locations - CM1432/CM1432 Plus/CM1732 . . . . .	7-7
7-5	Serial Number Locations - CM2033/CM2046/CM2546/CM2558 . . . . .	7-8
8-1	Poly-Pak Seal Installation . . . . .	8-7
8-2	Brake Cylinder Assembly . . . . .	8-10
8-3	Tilt Alarm Switch Leveling - Voltmeter Adjustment . . . . .	8-11
8-4	Pressure Adjustment Locations - Proportional Valve . . . . .	8-12
8-5	Pressure Adjustment Locations - Bang-Bang Valve . . . . .	8-13
11-1-1	Frame, Steering and Drive Installation . . . . .	11-1-2
11-1-2	Drive Motor Assemblies . . . . .	11-1-8
11-1-3	Rear Axle and Brake Installations (Prior to March 1992) . . . . .	11-1-10
11-1-4	Rear Axle and Brake Installations (March 1992 to Present) . . . . .	11-1-14
11-1-5	Frame Mounted Components Installation . . . . .	11-1-16
11-2-1	Covers, Controls, Tank and Valves Installation . . . . .	11-2-2
11-2-2	Control Valve Assembly - Hydro-Air (Machines with Bang-Bang Drive Built Prior to June 1992) . . . . .	11-2-8
11-2-3	Control Valve Assembly - Hydro-Air (Machines with Bang-Bang Drive Built June 1992 to Present) . . . . .	11-2-12
11-2-4	Control Valve Assembly - Hydro-Air (Machines with Proportional Drive) . . . . .	11-2-16
11-2-5	Batteries and Chargers Installation . . . . .	11-2-20
11-2-6	Battery Charger Assembly - Single Voltage . . . . .	11-2-24
11-2-7	Battery Charger Assembly - Dual Voltage . . . . .	11-2-26
11-3-1	Sizzor Arms Installation - CM2033 and CM2046 . . . . .	11-3-2
11-3-2	Sizzor Arms Installation - CM2546 and CM2558 . . . . .	11-3-4
11-3-3	Sizzor Arms Guard Installation (Prior to August 1992) . . . . .	11-3-10

## LIST OF ILLUSTRATIONS (cont.)

FIGURE NO.	TITLE	PAGE NO.
11-3-4	Sizzor Arms Guard Installation (August 1992 to May 1994) . . . . .	11-3-12
11-3-5	Sizzor Arms Guard Installation (May 1994 to June 1995) . . . . .	11-3-14
11-3-6	Sizzor Arms Guard Installation (June 1995 to Present) . . . . .	11-3-16
11-4-1	Standard Handrails and Accessories Installation . . . . .	11-4-2
11-4-2	Optional Fold-Down Handrail Installation . . . . .	11-4-8
11-4-3	Optional Extendable Deck Installation with Standard Handrails . . . . .	11-4-12
11-4-4	Optional Extendable Deck Installation with Fold-Down Handrails . . . . .	11-4-16
11-4-5	Steel Platform Console Box Assembly . . . . .	11-4-20
11-4-6	Molded Platform Console Box Assembly . . . . .	11-4-24
11-5-1	Brake Cylinder Assembly (Prior to March 1992) . . . . .	11-5-2
11-5-2	Brake Cylinder Assembly (March 1992 to Present) . . . . .	11-5-4
11-5-3	Lift Cylinder Sub-Assembly . . . . .	11-5-6
11-5-4	Steer Cylinder Assembly . . . . .	11-5-10
11-6-1	Hydraulic Diagram - Bang-Bang Drive . . . . .	11-6-2
11-6-2	Hydraulic Diagram - Proportional Drive . . . . .	11-6-6
11-7-2	Electrical Diagram - Toggle Switch Drive (Euro except French Spec) . . . . .	11-7-10
11-7-3	Electrical Diagram - Toggle Switch Drive (Australian Spec) . . . . .	11-7-11
11-7-4	Electrical Diagram - Toggle Switch Drive (French Spec) . . . . .	11-7-12
11-7-5	Electrical Diagram - PQ Controller Bang-Bang Drive (Euro except French Spec) . . . . .	11-7-13
11-7-6	Electrical Diagram - PQ Controller Bang-Bang Drive (Australian Spec) . . . . .	11-7-14
11-7-7	Electrical Diagram - PQ Controller Bang-Bang Drive (French Spec) . . . . .	11-7-15
11-7-8	Electrical Diagram - PQ Controller Proportional Drive (Euro except French Spec) . . . . .	11-7-16
11-7-9	Electrical Diagram - PQ Controller Proportional Drive (Austalian Spec) . . . . .	11-7-17
11-7-9A	Electrical Diagram - PQ Controller Proportional Drive (French Spec) . . . . .	11-7-18
11-7-10	Electrical Diagram - Circuit Cards . . . . .	11-7-19
11-7-11	Main Electrical Connector and Tools . . . . .	11-7-20
11-8-1	Decal Installation . . . . .	11-8-2
13-1-1	Frame, Steering and Drive Installation . . . . .	13-1-2
13-1-2	Drive Motor Assemblies . . . . .	13-1-4
13-1-3	Rear Axle and Brake Installations . . . . .	13-1-6
13-1-4	Frame Mounted Components Installation . . . . .	13-1-8
13-1-5	Battery Charger Assembly (Single Voltage) . . . . .	13-1-12
13-1-6	Battery Charger Assembly (Dual Voltage) (U.K. Specification Only) . . . . .	13-1-16
13-2-1	Electrical Components Installation . . . . .	13-2-2
13-2-2	Hydraulic Components and Covers Installation . . . . .	13-2-6
13-2-3	Control Valve Assembly - Hydro-Air . . . . .	13-2-10
13-3-1	Sizzor Arms Installation - CM1432/CM1432 Plus . . . . .	13-3-2
13-3-2	Sizzor Arms Installation - CM1732 . . . . .	13-3-6
13-3-3	Arm Guards Installation (Prior to July 1992) . . . . .	13-3-8
13-3-4	Arm Guards Installation (July 1992 to June 1995) . . . . .	13-3-10
13-3-5	Arm Guards Installation (June 1995 to Present) . . . . .	13-3-12
13-4-1	Platform and Handrail Installation . . . . .	13-4-2
13-4-2	Optional Platform Extension Installation . . . . .	13-4-6
13-4-3	Steel Platform Console Box Assembly . . . . .	13-4-10
13-4-4	Molded Platform Console Box Assembly . . . . .	13-4-14
13-5-1	Brake Cylinder Assembly . . . . .	13-5-2
13-5-2	Lift Cylinder Sub-Assembly . . . . .	13-5-4
13-5-3	Steer Cylinder Assembly . . . . .	13-5-8
13-6-1	Hydraulic Diagram - Standard . . . . .	13-6-2
13-7-2	Electrical Diagram - Toggle Switch Drive (Standard Euro Spec) . . . . .	13-7-8
13-7-3	Electrical Diagram - Toggle Switch Drive (Australian Spec) . . . . .	13-7-9
13-7-4	Electrical Diagram - Toggle Switch Drive (French Spec) . . . . .	13-7-10
13-7-5	Electrical Diagram - PQ Controller Bang-Bang Drive (Standard Euro Spec) . . . . .	13-7-11
13-7-6	Electrical Diagram - PQ Controller Bang-Bang Drive (Australian Spec) . . . . .	13-7-12
13-7-7	Electrical Diagram - PQ Controller Bang-Bang Drive (French Spec) . . . . .	13-7-13
13-7-8	Electrical Diagram - Circuit Cards . . . . .	13-7-15
13-7-9	Main Electrical Connector and Tools . . . . .	13-7-16

**LIST OF ILLUSTRATIONS (cont.)**

<b>FIGURE NO.</b>	<b>TITLE</b>	<b>PAGE NO.</b>
13-8-1	Decals Installation - CM1432/CM1432 Plus .....	13-8-2
13-8-2	Decals Installation - CM1732.....	13-8-6

**LIST OF TABLES**

<b>TABLE NO.</b>	<b>TITLE</b>	<b>PAGE NO.</b>
3-1	Control Panel Symbols .....	3-7
7-1	Hydraulic Oil.....	7-2
7-2	Lubrication Specifications .....	7-2
7-3	Critical Stability Weights - CM1432/CM1432 Plus/CM1732 .....	7-9
7-4	Critical Stability Weights - CM2033/CM2046/CM2546/CM2558) .....	7-9
8-1	Cylinder Piston Nut Torque Specifications .....	8-8
8-2	Holding Valve Torque Specifications.....	8-8
8-3	Preventive Maintenance and Inspection .....	8-15
9-1	Elevation System Troubleshooting .....	9-2
9-2	Chassis Troubleshooting .....	9-4
9-3	Hydraulic System Troubleshooting .....	9-8
9-4	Electrical System Troubleshooting .....	9-9
11-7-1	Electrical Diagrams and Components Chart - CM2033/CM2046/CM2546/CM2558 .	11-7-2
13-7-1	Electrical Diagrams and Components Chart - CM1432/CM1432 Plus/CM1732.....	13-7-2



**1-1. GENERAL.**

- a. This section prescribes the proper and safe practices for major areas of machine usage which have been divided into three basic categories: Driving, Operation and Maintenance. In order to promote proper usage of the machine, it is mandatory that a daily routine be established based on instruction given in this section. A maintenance program must also be established by a qualified person and must be followed to ensure that the machine is safe to operate.
- b. The user/operator of the machine should not accept operating responsibility until this manual has been read and operation of the machine, under the supervision of an experienced and qualified operator, has been completed. If there is a question on application and/or operation, JLG Industries Product Safety and Reliability should be consulted.

**WARNING**

**MODIFICATION OF THE MACHINE WITHOUT APPROVAL OF JLG INDUSTRIES, OR CERTIFICATION BY A NATIONALLY RECOGNIZED TESTING LAB TO BE IN CONFORMITY WITH APPLICABLE OSHA REGULATIONS, AND TO BE AT LEAST AS SAFE AS BEFORE MODIFICATION, IS PROHIBITED AND IS A VIOLATION OF OSHA RULES.**

**1-2. DRIVING/TOWING/CARRYING.**

- a. Before driving the machine the user must be familiar with the drive, steer and stopping characteristics. This is especially important when driving in close quarters.
- b. The user should be familiar with the driving surface before driving. The surface should be firm and level and grades should not exceed the allowable grade, as indicated on the CAUTION placard at the platform control station.

**Note**

**Remember that the key to safe and proper usage is common sense and its careful application.**

- c. Standard machine is not equipped with provisions for towing. Refer to Section 6 for emergency towing procedures.

**SPECIAL NOTE:**

**CERTAIN 'CARTOONS' IN THIS PUBLICATION SHOULD IN NO WAY BE CONSTRUED AS SHOWING THE PROPER USE OF THE MACHINES. THEY ARE INCLUDED TO PROVIDE VISUAL INDICATIONS OF INCORRECT EQUIPMENT OPERATION AND APPLICATION.**

**WARNING**

**FAILURE TO COMPLY WITH SAFETY PRECAUTIONS LISTED IN THIS SECTION AND ON MACHINE MAY RESULT IN MACHINE DAMAGE, PERSONNEL INJURY OR DEATH AND IS A SAFETY VIOLATION.**

- d. Carrying or loading the unit should be accomplished using a forklift vehicle of suitable capacity with the forks being positioned correctly beneath the indicated areas on the lower side of the frame.

1-3. ELECTROCUTION HAZARD.

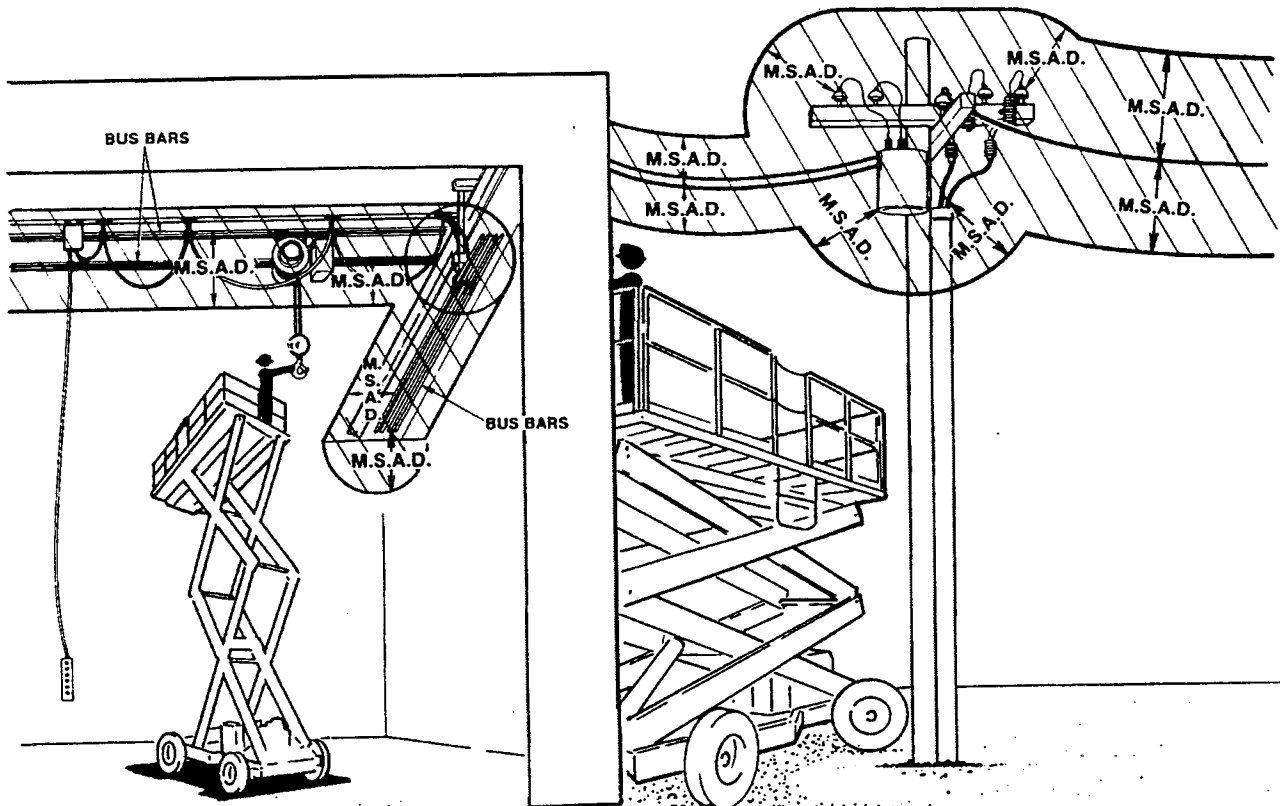

DENOTES PROHIBITED ZONE

M.S.A.D. = MINIMUM SAFE APPROACH DISTANCE  
 (SEE TABLE BELOW)  
 MAINTAIN M.S.A.D. FROM ALL  
 OTHER CHARGED LINES AND PARTS  
 AS WELL AS THOSE SHOWN.

Table

Minimum safe approach distances (M.S.A.D.) to energized (exposed or insulated) power lines and parts.

VOLTAGE RANGE (Phase to Phase)	MINIMUM SAFE APPROACH DISTANCE Meters
0 to 300V	AVOID CONTACT
Over 300V to 50KV	3
Over 50KV to 200KV	5
Over 200KV to 350KV	6
Over 350KV to 500KV	8
Over 500KV to 750KV	11
Over 750KV to 1000KV	14

**DANGER: DO NOT** maneuver machine or personnel inside PROHIBITED ZONE.  
 ASSUME all electrical parts and wiring are ENERGIZED unless known otherwise.

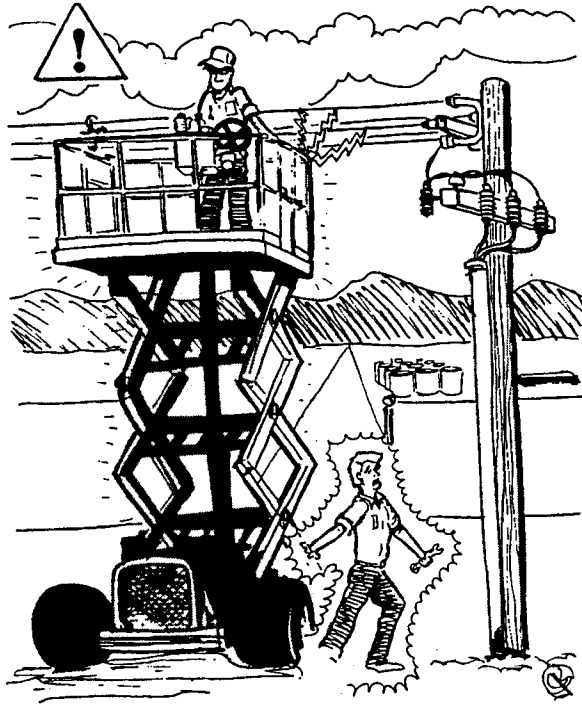

**MAINTAIN A SAFE DISTANCE FROM ELECTRICAL LINES AND APPARATUS.**

MAINTAIN SAFE CLEARANCE FROM ELECTRICAL LINES AND APPARATUS. ALLOW FOR PLATFORM SWAY, ROCK OR SAG AND ELECTRICAL LINE SWAYING. THE MACHINE DOES NOT PROVIDE PROTECTION FROM CONTACT WITH OR PROXIMITY TO AN ELECTRICALLY CHARGED CONDUCTOR.

MAINTAIN A CLEARANCE OF AT LEAST 3 METERS BETWEEN ANY PART OF THE MACHINE OR ITS LOAD AND ANY ELECTRICAL LINE OR APPARATUS CARRYING UP TO 50,000 VOLTS. 30 CENTIMETERS ADDITIONAL CLEARANCE IS REQUIRED FOR EVERY ADDITIONAL 30,000 VOLTS OR LESS.

#### 1-4. PRE-OPERATIONAL.

READ YOUR MANUAL. UNDERSTAND WHAT YOU'VE READ - THEN BEGIN OPERATIONS.

ALLOW ONLY THOSE AUTHORIZED AND QUALIFIED PERSONNEL TO OPERATE MACHINE WHO HAVE DEMONSTRATED THAT THEY UNDERSTAND SAFE AND PROPER OPERATION AND MAINTENANCE OF THE UNIT.

AN OPERATOR MUST NOT ACCEPT OPERATING RESPONSIBILITIES UNTIL ADEQUATE TRAINING HAS BEEN GIVEN BY COMPETENT AND AUTHORIZED PERSONS.

BEFORE OPERATION CHECK WORK AREA FOR BARE OVERHEAD ELECTRIC LINES, MACHINE TRAFFIC SUCH AS BRIDGE CRANES, HIGHWAY, RAILWAY AND CONSTRUCTION EQUIPMENT.

PRECAUTIONS TO AVOID ALL KNOWN HAZARDS IN THE WORK AREA MUST BE TAKEN BY THE OPERATOR AND HIS SUPERVISOR BEFORE STARTING THE WORK.

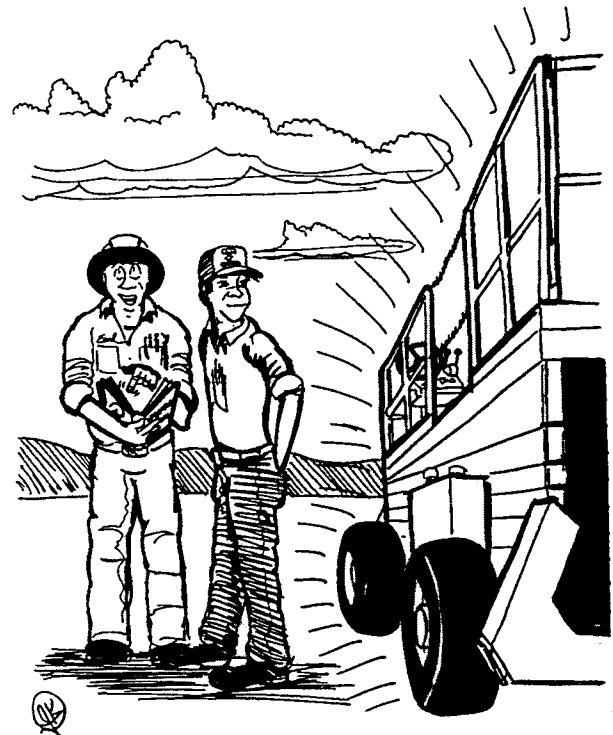

**READ YOUR MANUAL - UNDERSTAND WHAT YOU'VE READ - THEN BEGIN OPERATIONS.**

DO NOT OPERATE THIS MACHINE UNLESS IT HAS BEEN SERVICED AND MAINTAINED ACCORDING TO THE MANUFACTURERS SPECIFICATIONS AND SCHEDULE.

ENSURE DAILY INSPECTION AND FUNCTION CHECK IS PERFORMED PRIOR TO PLACING MACHINE INTO OPERATION.

NEVER DISABLE OR MODIFY ANY SAFETY DEVICE. ANY MODIFICATION OF THE MACHINE IS A SAFETY VIOLATION AND IS A VIOLATION OF OSHA RULES.

OPERATE MODELS CM1432, CM1432 PLUS, CM1732, CM2033 AND CM2546 WITH PLATFORM RAISED ONLY WHEN THERE IS NO WIND BLOWING.

DO NOT OPERATE MODELS CM2046 AND CM2558 WITH PLATFORM RAISED WHEN WIND CONDITIONS EXCEED 12.5 MPS.

NEVER OPERATE OR RAISE PLATFORM WHEN MACHINE IS ON A TRUCK OR OTHER VEHICLE.

APPROVED HEAD GEAR MUST BE WORN WHEN REQUIRED BY ALL OPERATING AND GROUND PERSONNEL.

READ AND OBEY ALL WARNINGS, CAUTIONS AND OPERATING INSTRUCTIONS ON MACHINE AND IN THIS MANUAL.

BE FAMILIAR WITH LOCATION AND OPERATION OF GROUND STATION CONTROLS.

ALWAYS USE 'THREE POINT CONTACT' WITH THE MACHINE. FACE THE MACHINE WHEN ENTERING OR LEAVING THE PLATFORM. 'THREE POINT CONTACT' MEANS THAT TWO HANDS AND ONE FOOT OR ONE HAND AND TWO FEET ARE IN CONTACT WITH THE MACHINE AT ALL TIMES DURING MOUNT AND DISMOUNT.

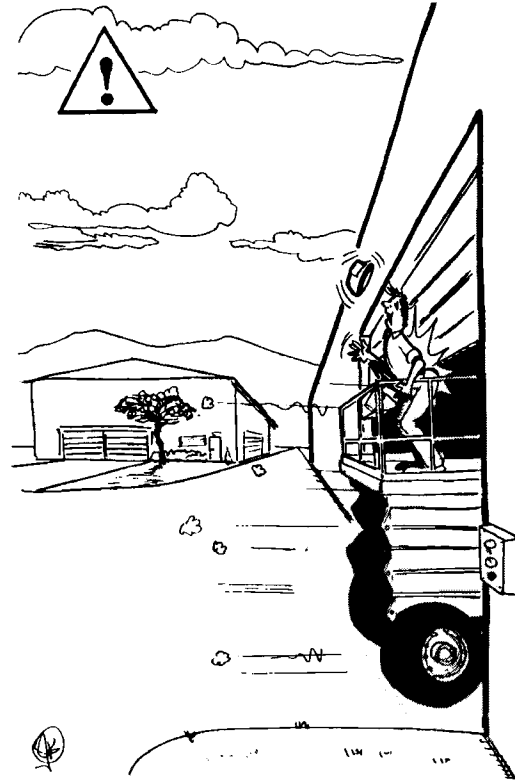

**ALWAYS LOOK IN THE DIRECTION OF TRAVEL.**

### 1-5. DRIVING.

WATCH FOR OBSTRUCTIONS AROUND MACHINE AND OVERHEAD WHEN DRIVING.

CHECK TRAVEL PATH FOR PERSONS, HOLES, BUMPS, DROP-OFFS, OBSTRUCTIONS, DEBRIS, AND COVERINGS WHICH MAY CONCEAL HOLES AND OTHER HAZARDS.

WHEN DRIVING IN HIGH SPEED, SWITCH TO LOW BEFORE STOPPING. TRAVEL GRADES IN LOW DRIVE ONLY.

DO NOT DRIVE ON GRADES AND SIDESLOPES EXCEEDING THOSE INDICATED ON CAUTION PLACARD AT MACHINE PLATFORM.

BEFORE DRIVING ON FLOORS, BRIDGES, TRUCKS AND OTHER SURFACES, CHECK ALLOWABLE CAPACITY OF SURFACES.



DO NOT TRAVEL ON SOFT OR UNEVEN SURFACES, AS TIPPING WILL OCCUR.

DO NOT USE HIGH SPEED DRIVE IN RESTRICTED OR CLOSE QUARTERS OR WHEN DRIVING IN REVERSE.

BE AWARE OF STOPPING DISTANCES WHEN TRAVELING IN HIGH AND LOW SPEEDS.

ALWAYS POST A LOOKOUT AND SOUND HORN WHEN DRIVING IN AREAS WHERE VISION IS OBSTRUCTED.

KEEP NON-OPERATING PERSONNEL AT LEAST 2 METERS AWAY FROM MACHINE DURING DRIVING OPERATIONS.

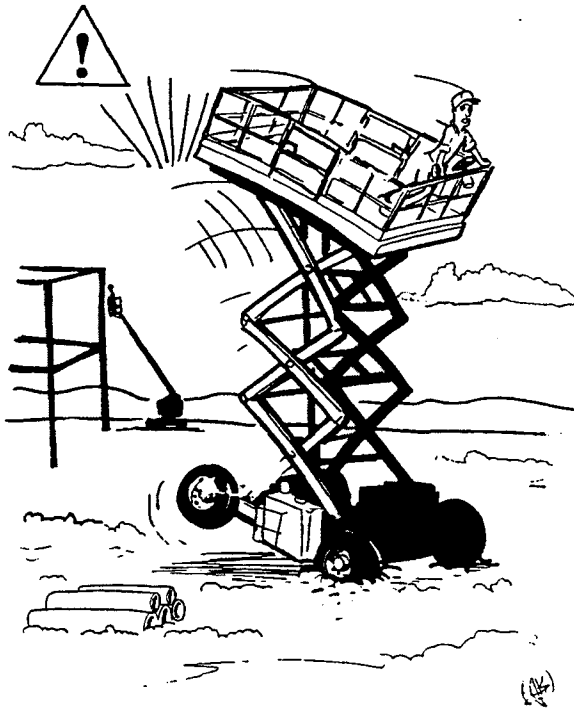

NEVER OPERATE ON SOFT OR UNEVEN SURFACES.

## 1-6. OPERATION.

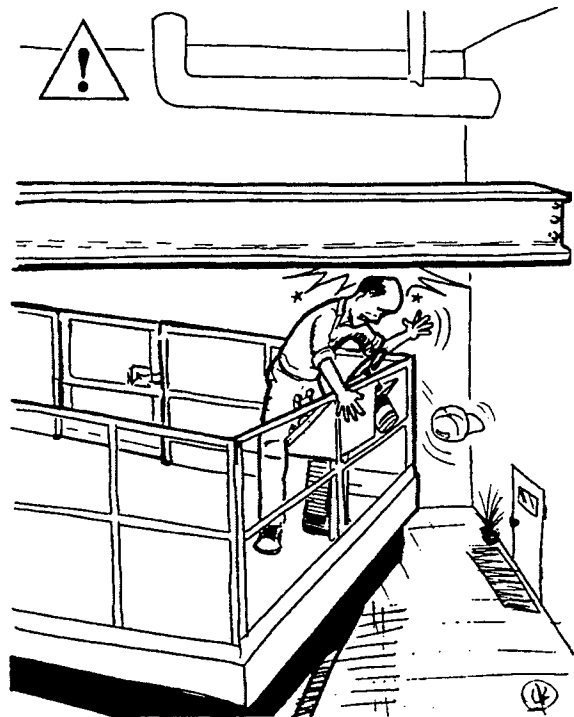

THOROUGHLY CHECK ALL CLEARANCES BEFORE POSITIONING PLATFORM.

READ YOUR MANUAL, UNDERSTAND WHAT YOU'VE READ - THEN BEGIN OPERATIONS.

DO NOT OPERATE ANY MACHINE ON WHICH DANGER, WARNING, CAUTION OR INSTRUCTION PLACARDS OR DECALS ARE MISSING OR ILLEGIBLE.

NEVER EXCEED MANUFACTURERS RATED PLATFORM CAPACITY - REFER TO CAPACITY DECAL ON MACHINE. DISTRIBUTE LOAD EVENLY ON PLATFORM FLOOR.

ENSURE MACHINE IS POSITIONED ON A FIRM, LEVEL AND UNIFORM SURFACE BEFORE RAISING PLATFORM.

NEVER 'SLAM' A CONTROL SWITCH OR LEVER THROUGH NEUTRAL TO OPPOSITE DIRECTION. ALWAYS RETURN SWITCH TO NEUTRAL AND STOP; THEN MOVE SWITCH TO THE DESIRED POSITION. OPERATE LEVERS WITH SLOW, EVEN PRESSURE.

NEVER OPERATE A MALFUNCTIONING MACHINE. IF A MALFUNCTION OCCURS, SHUT DOWN THE MACHINE, RED TAG IT, AND NOTIFY PROPER AUTHORITIES.

CHECK CLEARANCES ABOVE, ON SIDES AND BOTTOM OF PLATFORM WHEN RAISING AND LOWERING PLATFORM.



**SIZZOR ARMS ARE NOT FOR CLIMBING.**

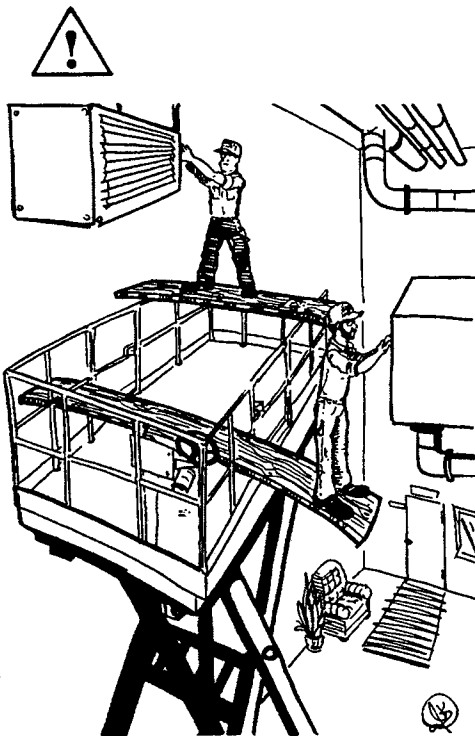

**ALWAYS STAND ON PLATFORM FLOOR, NOT ON BOXES, PLANKS OR RAILINGS.**

NEVER USE SIZZOR ARMS TO GAIN ACCESS TO OR LEAVE PLATFORM.

DO NOT ATTACH OVERHANGING LOADS TO THE PLATFORM OR INCREASE THE PLATFORM SIZE WITH UNAUTHORIZED DECK EXTENSIONS OR ATTACHMENTS.

DO NOT ELEVATE PLATFORM WHILE DRIVING, OR UNLESS MACHINE IS LEVEL.

DO NOT TIE OFF MACHINE TO ANY ADJACENT STRUCTURE. NEVER ATTACH WIRE, CABLE OR ANY SIMILAR ITEMS TO PLATFORM.

DURING ENTRY OR EXIT ABOVE GROUND OSHA REQUIRES THAT SAFETY BELT BE ATTACHED TO THE STRUCTURE BEING ENTERED.

TO AVOID FALLING - USE EXTREME CAUTION WHEN ENTERING OR LEAVING PLATFORM ABOVE GROUND. ENTER OR EXIT THRU GATE ONLY. PLATFORM MUST BE WITHIN 30 CENTIMETERS OF ADJACENT - SAFE AND SECURE - STRUCTURE.

NO STUNT DRIVING OR HORSEPLAY IS PERMITTED.

DO NOT ALLOW PERSONNEL TO TAMPER WITH, SERVICE, OR OPERATE THIS MACHINE FROM THE GROUND WITH PERSONNEL IN PLATFORM EXCEPT IN AN EMERGENCY.

WHEN TWO OR MORE PERSONS ARE IN PLATFORM, THE OPERATOR SHALL BE RESPONSIBLE FOR ALL MACHINE OPERATIONS.

DURING OPERATION KEEP ALL BODY PARTS INSIDE PLATFORM RAILINGS.

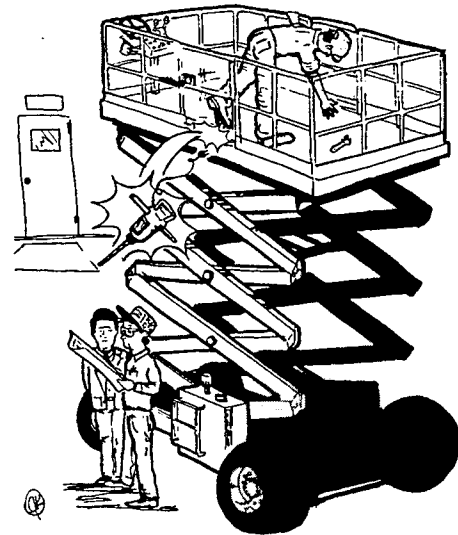

**KEEP EVERYONE CLEAR OF A WORKING PLATFORM.**

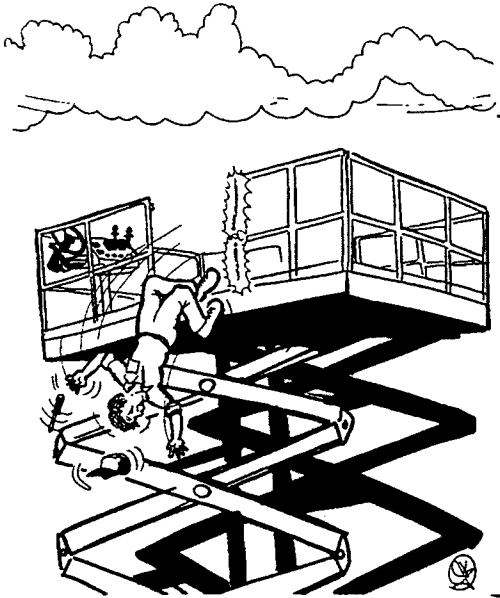

**KEEP GATE CLOSED AT ALL TIMES.**

NEVER POSITION LADDERS, STEPS, OR SIMILAR ITEMS ON UNIT TO PROVIDE ADDITIONAL REACH FOR ANY PURPOSE.

WHEN RIDING IN OR WORKING FROM PLATFORM BOTH FEET MUST BE FIRMLY POSITIONED ON DECK.

DO NOT EXTEND REACH LIMITS OF THIS MACHINE WITH ADDITIONAL EQUIPMENT SUCH AS PLANKS, BOXES, ETC.

OBSERVE EXTREME CAUTION AT ALL TIMES TO PREVENT OBSTACLES FROM STRIKING OR INTERFERING WITH OPERATING CONTROLS AND PERSONS IN THE PLATFORM.

ENSURE THAT OPERATORS OF OTHER OVERHEAD AND FLOOR LEVEL MACHINES ARE AWARE OF THE AERIAL PLATFORMS PRESENCE. DISCONNECT POWER TO OVERHEAD CRANES. BARRICADE FLOOR AREA IF NECESSARY.

DO NOT OPERATE WITHOUT HANDRAILS IN PLACE AND SECURED. IT IS A SAFETY VIOLATION.

DO NOT STEP OUTSIDE OF HANDRAILS.

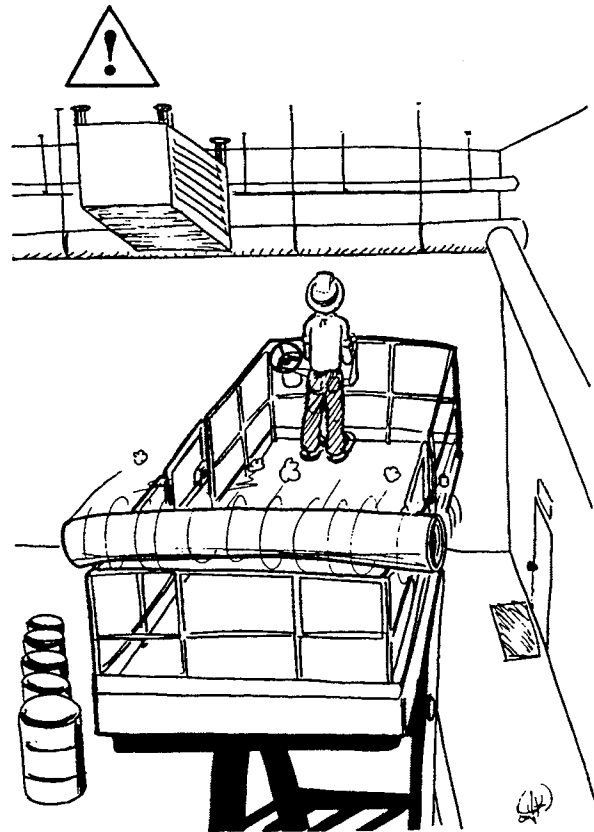

PLATFORM RAILS ARE NOT FOR HANDLING MATERIAL.

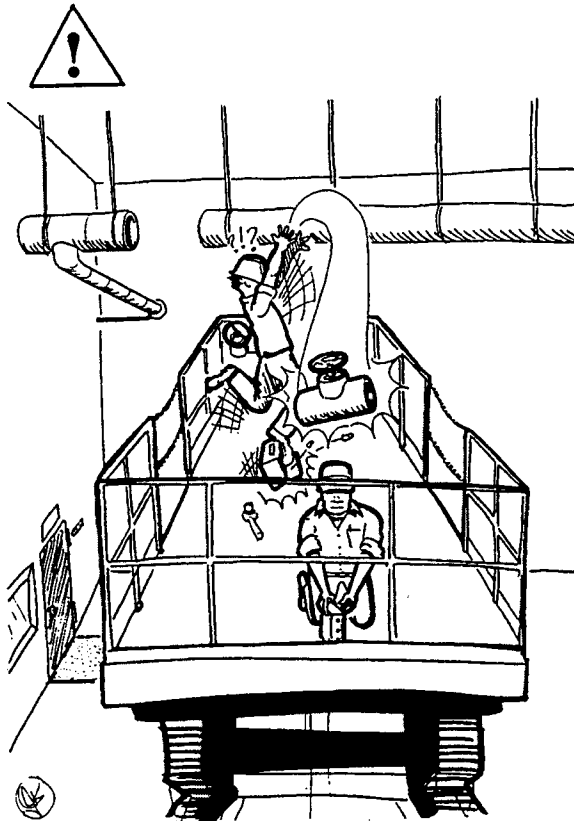

KEEP SHOES AND PLATFORM DECK CLEAN.

ALWAYS ENSURE THAT POWER TOOLS ARE PROPERLY STOWED AND NEVER LEFT HANGING BY THEIR CORD FROM THE PLATFORM WORK AREA.

AVOID ACCUMULATION OF DEBRIS ON PLATFORM WORK AREA. KEEP MUD, OIL, GREASE AND OTHER SLIPPERY SUBSTANCES FROM FOOTWEAR AND PLATFORM DECK.

**1-7. TOWING AND HAULING.**

NEVER ATTEMPT TO TOW OR PULL MACHINE. ALWAYS CARRY MACHINE WITH FORKLIFT OF SUITABLE CAPACITY.

HAVE PLATFORM COMPLETELY EMPTY OF TOOLS AND DEBRIS BEFORE CARRYING.

WHEN LIFTING MACHINE, POSITION FORKS ONLY AT DESIGNATED AREA AT REAR OF MACHINE.

HAVE PLATFORM FULLY RETRACTED WHILE MACHINE IS BEING CARRIED.

NEVER ALLOW PERSONNEL IN PLATFORM WHILE CARRYING.

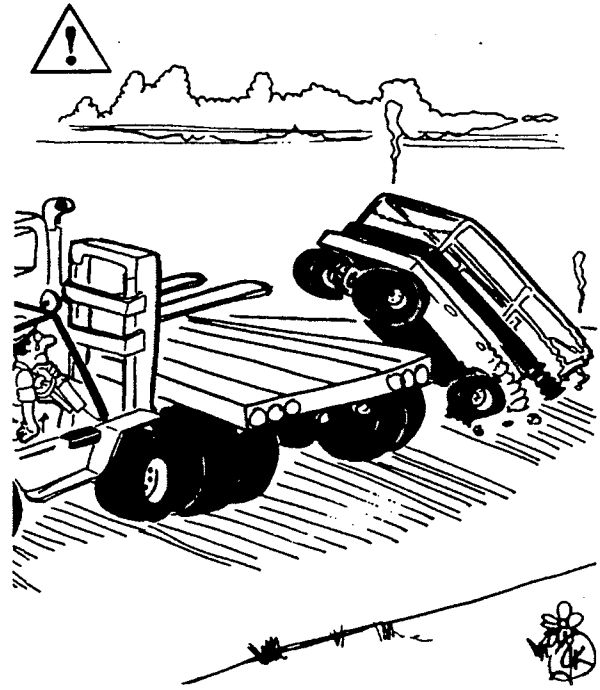

LIFT MACHINE AT DESIGNATED AREA ONLY.

## 1-8. MAINTENANCE.

- a. This section contains the general safety precautions which must be observed during maintenance of the aerial platform. It is of utmost importance that maintenance personnel pay strict attention to these warnings and precautions to avoid possible injury to themselves or others or damage to the equipment. A maintenance program must be established by a qualified person and must be followed to ensure that the machine is safe to operate.

### WARNING

**MODIFICATION OF THE MACHINE WITHOUT CERTIFICATION BY A RESPONSIBLE AUTHORITY THAT THE MACHINE IS AT LEAST AS SAFE AS ORIGINALLY MANUFACTURED IS A SAFETY VIOLATION.**

- b. The specific precautions to be observed during machine maintenance are inserted at the appropriate point in the manual. These precautions are, for the most part, those that apply when servicing hydraulic and larger machine component parts.
- c. Your safety, and that of others, is the first consideration when engaging in the maintenance of equipment. Always be conscious of weight.

Never attempt to move heavy parts without the aid of a mechanical device. Do not allow heavy objects to rest in an unstable position. When raising a portion of the equipment, ensure that adequate support is provided.

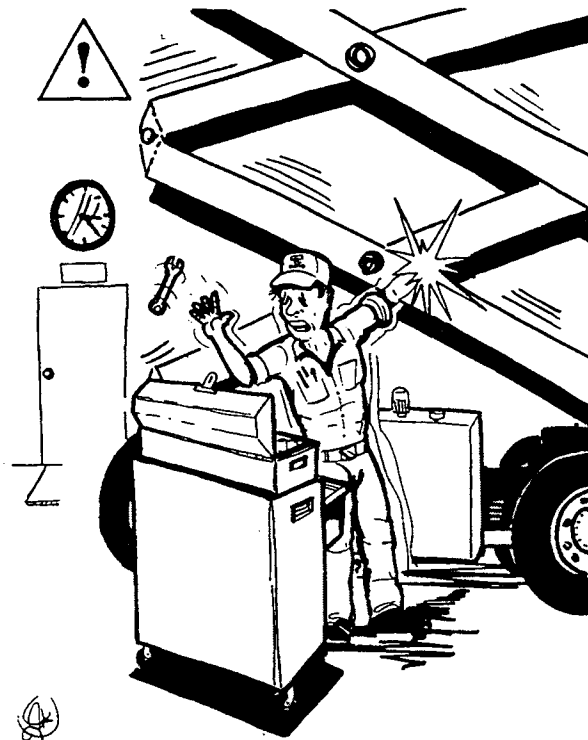

**USE SAFETY PROPS WHEN PERFORMING MAINTENANCE.**

**ALWAYS DISCONNECT BATTERIES WHEN REPLACING ELECTRICAL COMPONENTS.**

**REMOVE RINGS, WATCHES AND JEWELRY WHEN PERFORMING ANY MAINTENANCE.**

**DO NOT WEAR LOOSE FITTING CLOTHING OR LONG HAIR UNRESTRAINED, WHICH IS APT TO BECOME CAUGHT ON, OR ENTANGLED IN EQUIPMENT.**

**USE ONLY CLEAN APPROVED NONFLAMMABLE CLEANING SOLVENTS.**

**SHUT OFF ALL POWER CONTROLS BEFORE MAKING ADJUSTMENTS, LUBRICATING OR PERFORMING ANY OTHER MAINTENANCE.**

**NEVER WORK UNDER AN ELEVATED PLATFORM UNTIL IT HAS BEEN RESTRAINED FROM MOVEMENT WITH SAFETY PROPS, BLOCKING OR OVERHEAD SLING.**

**NEVER ALTER, REMOVE OR SUBSTITUTE ANY ITEM SUCH AS COUNTERWEIGHTS, FOAM FILLED TIRES, BATTERIES, ETC. WHICH WOULD REDUCE THE OVERALL WEIGHT OR BASE STABILITY OF THE MACHINE.**

**2-1. GENERAL.**

This section provides the necessary information needed by those personnel that are responsible to place the machine in operation readiness, and lists checks that are performed prior to use of the machine. It is important that the information contained in this section be read and understood before any attempt is made to operate the machine. Ensure that all the necessary inspections have been completed successfully before placing the machine into service. These procedures will aid in obtaining maximum service life and safe operation.

**IMPORTANT**

**SINCE THE MACHINE MANUFACTURER HAS NO DIRECT CONTROL OVER THE FIELD INSPECTION AND MAINTENANCE, SAFETY IS THE RESPONSIBILITY OF THE OWNER/OPERATOR.**

**2-2. PREPARATION FOR USE.**

- a. Before a new machine is put into operation it must be carefully inspected for any evidence of damage resulting from shipment and inspected periodically thereafter, as outlined in paragraph 2-3, Delivery and Periodic Inspection. The unit should be thoroughly checked for hydraulic leaks during initial start-up and run. A check of all components should be made to assure their security.
- b. All preparation necessary to place the machine in operation readiness status are the responsibility of management personnel. Preparation requires good common sense, (i.e. lift works smoothly and brakes operate properly) coupled with a series of visual inspections. The mandatory requirements are given in paragraph 2-4, Daily Walk Around Inspection.
- c. It should be assured that the items appearing in the Delivery and Periodic Inspection and Functional Check are complied with prior to putting the machine into service.

**2-3. DELIVERY AND PERIODIC INSPECTION.****Note**

**This machine requires periodic safety and maintenance inspections by a JLG Dealer.**

- a. The following checklist provides a systematic inspection to assist in detecting defective, damaged, or improperly installed parts. The checklist denotes the items to be inspected and conditions to examine. Periodic inspection shall be performed monthly or more often when required by environment, severity, and frequency of usage.

- (1). Handrail Assemblies.  
Properly installed; no loose or missing parts; no visible damage.
- (2). Platform Assembly.  
No visible damage; free of dirt and debris.
- (3). Sizzor Arms.  
No visible damage, abrasions and/or distortions.
- (4). Electrical Cable.  
No visible damage; properly secured.
- (5). Pivot Pins.  
No loose or missing retaining hardware; no damage or wear to pin heads which would cause pin to rotate; no evidence of pin or bushing wear.
- (6). Lift Cylinder.  
No rust, nicks, scratches or foreign material on piston rod. No leakage. Evidence of proper lubrication.
- (7). Frame.  
No visible damage; loose or missing hardware (top and underside).
- (8). Tire and Wheel Assemblies.  
No loose or missing lug nuts; no visible damage.
- (9). Sliding Wear Pad Blocks.  
No excessive wear; adequate lubrication.
- (10). Hydraulic Oil Supply.

**Note**

**Prior to checking the hydraulic oil level, operate the machine through one complete cycle of the lift function (full up and down). Failure to do so will result in an incorrect oil level reading on the hydraulic tank.**

Level should be at full mark on side of hydraulic tank (all systems shut down, machine in stowed position) immediately after up-down cycle.

- (11). Steer Cylinder.  
No rust, nicks, scratches or foreign material on piston rod; no leakage.

- (12). Steer Linkage.  
No loose or missing parts; no visible damage.
- (13). Front Spindle Assemblies.  
No excessive wear; no damage.
- (14). Control Boxes. (Console and Ground)  
Switches operable; no visible damage; placards secure and legible. If equipped, controller operable; no visible damage.
- (15). Batteries.  
Proper electrolyte level; cable connections tight; no visible damage; no corrosion at battery cable connections.
- (16). Hydraulic Pump and Valves.  
No leakage; units secure.
- (17). Platform Placards.  
No visible damage; placards secure and legible.

#### 2-4. DAILY WALK-AROUND INSPECTION.

- a. It is the user's responsibility to inspect the machine before the start of each workday. It is recommended that each user inspect the machine before operation, even if the machine has already been put into service under another user. This Daily Walk-Around Inspection is the preferred method of inspection. (See Figure 2-1.)
- b. In addition to the Daily Walk-Around Inspection, be sure to include the following as part of the daily inspection:
  - (1). Overall Cleanliness.  
Check all standing surfaces for oil, fuel and hydraulic oil spillage and foreign objects. Ensure overall cleanliness.
  - (2). Placards.  
Keep all information and operating placards clean and unobstructed. Cover when spray painting or shot blasting to protect legibility.
  - (3). Operators, Service, and Parts Manual.  
Ensure a copy of this manual is enclosed in the manual storage box.

- (4). Machine Log.  
Ensure a machine operating record or log is kept. Check to see that it is current and that no entries have been left uncleared, leaving machine in an unsafe condition for operation.
  - (5). Daily Lubrication.  
For those items pointed out in the Daily Walk-Around Inspection requiring daily lubrication, refer to the Lubrication Chart, Figures 7-2 and 7-3, for specific requirements.
- c. Perform the following checks and services before attempting to operate the machine.

#### WARNING

**TO AVOID INJURY DO NOT OPERATE A MACHINE UNTIL ALL MALFUNCTIONS HAVE BEEN CORRECTED. USE OF A MALFUNCTIONING MACHINE IS A SAFETY VIOLATION.**

- (1). Start each day with fully charged batteries.
- (2). Ensure that all items requiring lubrication are serviced in accordance with the Lubrication Chart, Figures 7-2 and 7-3.
- (3). Perform functional checks in accordance with paragraph 2-5, Daily Functional Check.

#### 2-5. DAILY FUNCTIONAL CHECK.

#### WARNING

**TO AVOID INJURY DO NOT OPERATE A MACHINE UNTIL ALL MALFUNCTIONS HAVE BEEN CORRECTED. USE OF A MALFUNCTIONING MACHINE IS A SAFETY VIOLATION.**

- a. A functional check of all systems should be performed, under no load, once the walk-around inspection is complete, in an area free of overhead and ground level obstructions. Perform pre-load functional check in accordance with the following procedure:
  - (1). Raise and lower platform several times. Check for smooth elevation and lowering. Check for High Drive cut-out as platform begins to raise.
  - (2). Drive forward and reverse, check for proper operation.
  - (3). Check that parking brake holds when machine is driven up a hill, not to exceed rated gradeability, and stopped.



- (4). Steer left and right. Check for proper operation.
- (5). Check hydraulic oil reservoir dipstick. Refer to Lubrication Chart.

## 2-6. TORQUE REQUIREMENTS.

The Torque Chart, Figure 7-1, consists of standard torque values based on bolt diameter and grade, also specifying dry and wet torque values in accordance with recommended shop practices. This chart is provided as an aid to the operator in the event he/she notices a condition that requires prompt attention during the walk-around inspection or during operation until the proper service personnel can be notified. Section 7 provides specific torque values and periodic maintenance procedures with a listing of individual components. Utilizing this Torque Chart in conjunction with the preventive maintenance section in Section 8, will enhance safety, reliability and performance of the machine.

## 2-7. BATTERY CHARGING.

At the end of the work day, the batteries should be charged for the next days work. Position the Emergency Stop switch to OFF. Prior to charging, be sure electrolyte covers plates. Connect the battery charger to a properly grounded 110 Volt receptacle using a suitable extension cord. Set the battery charger timer switch, if equipped, for the desired charging time. After charging, check the electrolyte level of the batteries and adjust accordingly. Add distilled water only to batteries. A fully charged battery will have a specific gravity of between 1.260 - 1.275 on a hydrometer.

## CAUTION

**WHEN ADDING DISTILLED WATER TO THE BATTERIES, A NON-METALLIC CONTAINER AND/OR FUNNEL MUST BE USED. ADD WATER ONLY TO LEVEL INDICATOR OR 3/8 INCH (0.95 CM) ABOVE SEPARATORS.**

**NO OPEN FLAMES OR SMOKING WHEN CHARGING BATTERIES.**

**CHARGE BATTERIES ONLY IN A WELL VENTILATED AREA.**

**ENSURE THAT BATTERY ACID DOES NOT COME INTO CONTACT WITH SKIN OR CLOTHING.**

## Notes

**Be sure to disconnect and store any extension cords after charging batteries and before putting machine into service.**

**To avoid electrolyte overflow, add distilled water to batteries after charging.**

**Refer to JLG Publication 3120366 for applicable battery charger information.**

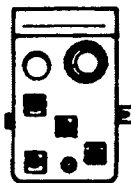
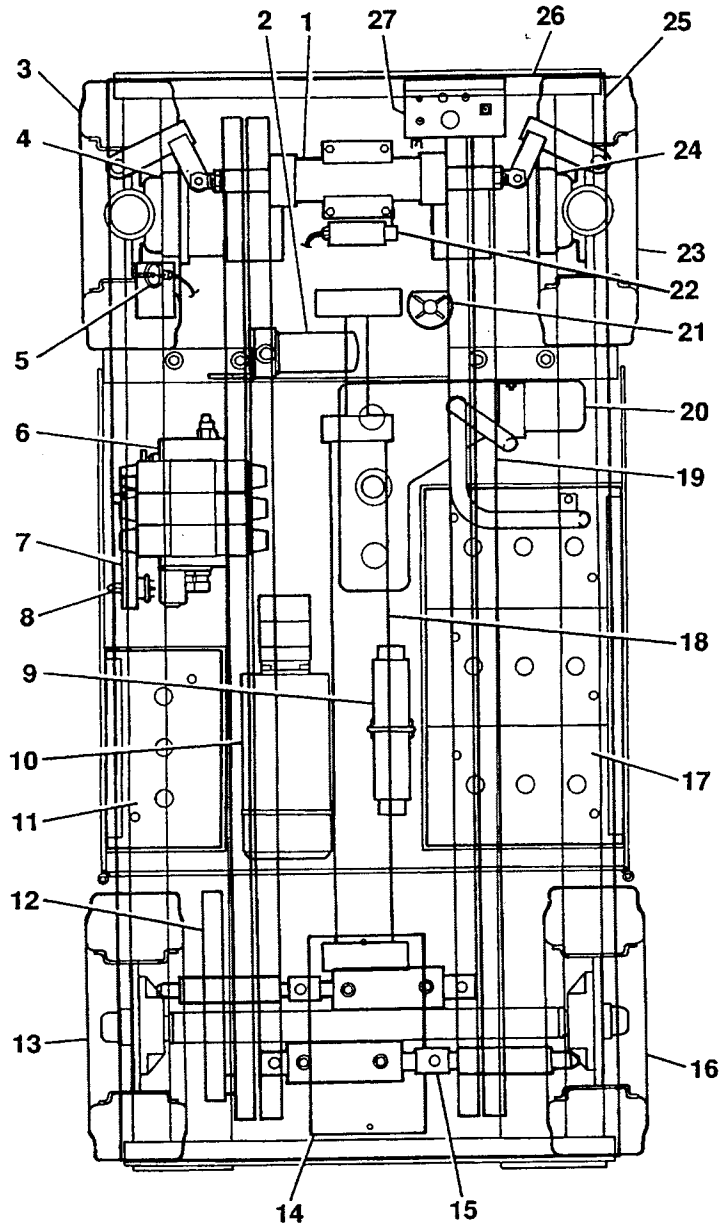

Insert A. Platform Control Box.  
Machines Built After October 1992.

Figure 2-1. Daily Walk-Around Inspection - CM1432/CM1432 Plus/CM1732. (Sheet 1 of 2)

**GENERAL.**

Begin the "Walk-Around Inspection" at Item 1, as noted on the diagram. Continue to the right (counterclockwise viewed from top) checking each item in sequence for the conditions listed in the "Walk-Around Inspection Checklist".

**WARNING**

**TO AVOID INJURY DO NOT OPERATE MACHINE UNTIL ALL MALFUNCTIONS HAVE BEEN CORRECTED. USE OF A MALFUNCTIONING MACHINE IS A SAFETY VIOLATION.**

**TO AVOID POSSIBLE INJURY, BE SURE MACHINE POWER IS "OFF" DURING "WALK-AROUND INSPECTION".**

**Note**

Do not overlook visual inspection of chassis underside. Checking this area often results in discovery of conditions which could cause extensive machine damage.

1. Steer Cylinder and Linkage - No loose or missing parts, no visible damage. No steer cylinder leaks or damage.
2. Hydraulic Filter - No visible damage, properly secured, no evidence of leakage.
3. Steer/Drive Wheel and Tire Assembly, Left Front - Properly secured, no loose or missing lug nuts, no visible damage.
4. Drive Motor, Left Front - No visible damage, no evidence of leakage.
5. Manual Descent Cable and Pull Ring - Properly secured, no loose or missing parts, no visible damage.
6. Control Valve Installation - No loose or missing parts, no evidence of leakage. No unsupported wires or hoses, no damaged or broken wires.
7. Ground Controls - Switches operable, no visible damage, placards secure and legible.
8. Battery Switch - Properly secured, no visible damage, placard in place and legible.
9. Cushion Cylinder (Accumulator) - Properly secured, no visible damage, no evidence of leakage.
10. Motor/Pump Unit - Properly secured, no visible damage, no evidence of hydraulic leaks.
11. Battery Installation - Proper electrolyte level, cables secure, no damage or corrosion. Holddowns secure.
12. Safety Prop - Stored securely, no visible damage or missing parts.
13. Wheel and Tire Assembly, Left Rear - Properly secured, no loose or missing lug nuts, no visible damage.
14. Battery Charger - No damage, properly secured.
15. Parking Brake - Brake cylinders secure, no loose or missing parts, no visible damage or cylinder leaks.
16. Wheel and Tire Assembly, Right Rear - Properly secured, no loose or missing lug nuts, no visible damage.
17. Battery Installation - Proper electrolyte level, cables secure, no damage or corrosion. Holddowns secure.
18. Lift Cylinder - Properly secured, no visible damage, no loose or missing parts, no evidence of leakage.
19. Sizzor Arms and Sliding Wear Pads - Properly secured, no visible damage, evidence of proper lubrication. Inspect sizzor arm guards for damage and proper installation.
20. Hydraulic Reservoir - No visible damage or missing parts, no evidence of leaks. Recommended hydraulic fluid level on dipstick (Cold fluid, system shut down, machine in stowed position.). Breather cap secure and working.
21. Tilt Alarm - Properly secured, no loose or missing parts, no visible damage.
22. High Drive and Drive Limit Switches - Properly secured, no visible damage. Cam in place and secure.
23. Steer/Drive Wheel and Tire Assembly, Right Front - Properly secured, no loose or missing lug nuts, no visible damage.
24. Drive Motor, Right Front - No visible damage, no evidence of leakage.
25. Handrail Installation - All railings securely attached, no visible damage, no missing parts, chain in proper working order.
26. Platform Assembly - No loose or missing parts, no visible damage, platform deck extension operates properly.
27. Platform Controls - Properly secured, no loose or missing parts, no visible damage. Placards secure and legible, control switches return to neutral. Control markings legible, manual in manual storage box.

Figure 2-1. Daily Walk-Around Inspection - CM1432/CM1432 Plus/CM1732. (Sheet 2 of 2)

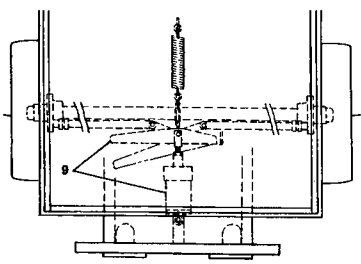
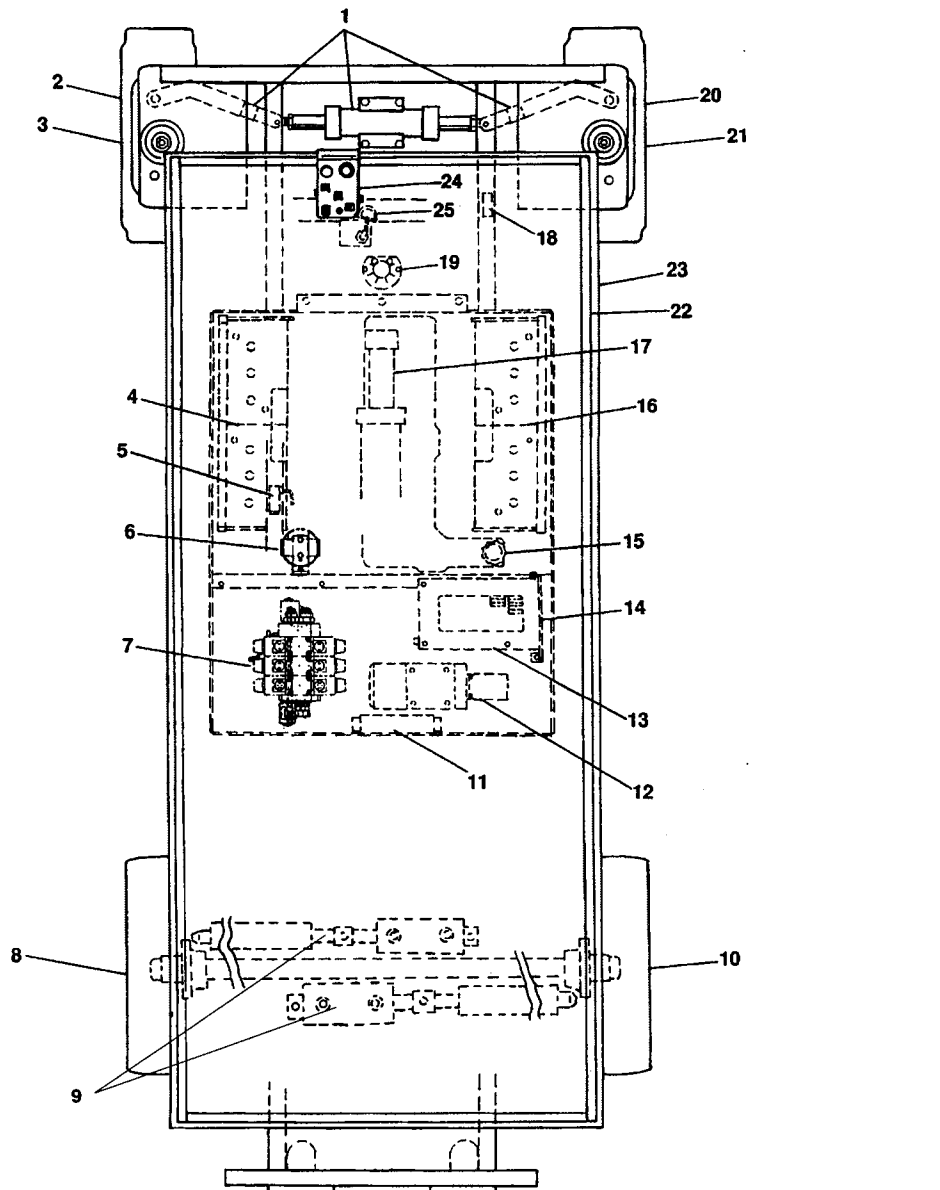

**Insert A. Parking Brake -  
Machines Built Before March 1992.**



**Insert B. Platform Control Box -  
Machines Built Before August 1992.**

**Figure 2-2. Daily Walk-Around Inspection - CM2033/CM2046/CM2546/CM2558. (Sheet 1 of 2)**

**GENERAL.**

Begin the "Walk-Around Inspection" at Item 1, as noted on the diagram. Continue to the right (counterclockwise viewed from top) checking each item in sequence for the conditions listed in the "Walk-Around Inspection Checklist".

**WARNING**

**TO AVOID INJURY DO NOT OPERATE MACHINE UNTIL ALL MALFUNCTIONS HAVE BEEN CORRECTED. USE OF A MALFUNCTIONING MACHINE IS A SAFETY VIOLATION.**

**TO AVOID POSSIBLE INJURY, BE SURE MACHINE POWER IS "OFF" DURING "WALK-AROUND INSPECTION".**

**Note**

**Do not overlook visual inspection of chassis underside. Checking this area often results in discovery of conditions which could cause extensive machine damage.**

1. Steer Cylinder and Linkage - No loose or missing parts, no visible damage. No steer cylinder leaks or damage.
2. Steer/Drive Wheel and Tire Assembly, Left Front - Properly secured, no loose or missing lug nuts, no visible damage.
3. Drive Motor, Left Front - No visible damage, no evidence of leakage.
4. Battery Installation - Proper electrolyte level, cables secure, no damage or corrosion. Holddowns secure.
5. Limit Switch - Properly secured, no visible damage.
6. Hydraulic Filter - No visible damage, properly secured, no evidence of leakage.
7. Control Valve Installation - No loose or missing parts, no evidence of leakage. No unsupported wires or hoses, no damaged or broken wires.
8. Wheel and Tire Assembly, Left Rear - Properly secured, no loose or missing lug nuts, no visible damage.
9. Parking Brake - No loose or missing parts, no visible damage. No cylinder leaks.
10. Wheel and Tire Assembly, Right Rear - Properly secured, no loose or missing lug nuts, no visible damage.
11. Cushion Cylinder - Properly secured, no visible damage, no evidence of leakage.
12. Motor/Pump Unit - Properly secured, no visible damage, no evidence of hydraulic leaks.
13. Battery Charger - No damage, properly secured.
14. Ground Controls - Switches operable, no visible damage, placards secure and legible.
15. Hydraulic Reservoir - No visible damage or missing parts, no evidence of leaks. Recommended hydraulic fluid level on dipstick. (Cold fluid, system shut down, machine in stowed position.) Breather cap secure and working.
16. Battery Installation - Proper electrolyte level, cables secure, no damage or corrosion. Holddowns secure.
17. Lift Cylinder - Properly secured, no visible damage, no loose or missing parts, no evidence of leakage.
18. Sizzor Arms and Sliding Wear Pads - Properly secured, no visible damage, evidence of proper lubrication. Inspect sizzor arm guards for damage and proper installation.
19. Tilt Alarm - Properly secured, no loose or missing parts, no visible damage.
20. Steer/Drive Wheel and Tire Assembly, Right Front - Properly secured, no loose or missing lug nuts, no visible damage.
21. Drive Motor, Right Front - No visible damage, no evidence of leakage.
22. Handrail Installation - All railings securely attached, no visible damage, no missing parts, chain in proper working order.
23. Platform Assembly - No loose or missing parts, no visible damage, platform deck extension operates properly.
24. Platform Controls - Properly secured, no loose or missing parts, no visible damage. Placards secure and legible, control switches return to neutral. Control markings legible, manual in manual storage box.  
NOTE: Platform Control Box on machines built after October 1992 shown; see Insert A for Platform Control Box on machines built before October 1992.
25. Manual Descent Cable and Pull Ring - Properly secured, no loose or missing parts, no visible damage.  
NOTE: Manual Descent Handle is shown in location used on machines built until December 1991. Machines built after December 1991 have the Manual Descent Cable located on the left front side of the frame.
26. Valves, Valve Fittings, Hosing and Tubing - properly secured, no loose or missing parts, no visible damage, no evidence of leakage.

Figure 2-2. Daily Walk Around Inspection - CM2033/CM2046/CM2546/CM2558. (Sheet 2 of 2)



**3-1. GENERAL.****IMPORTANT**

**SINCE THE MANUFACTURER HAS NO DIRECT CONTROL OVER MACHINE APPLICATION AND OPERATION, CONFORMANCE WITH GOOD SAFETY PRACTICES IN THESE AREAS IS THE RESPONSIBILITY OF THE USER AND HIS OPERATING PERSONNEL.**

This section provides the necessary information needed to understand control functions. Included in this section are the operating characteristics and limitations, and functions and purposes of controls and indicators. It is important that the user read and understand the proper procedures before operating the machine. These procedures will aid in obtaining optimum service life and safe operation.

**3-2. PERSONNEL TRAINING.**

- a. The sizzor lift is a personnel handling device; therefore, it is essential that it be operated and maintained only by authorized personnel who have demonstrated that they understand the proper use and maintenance of the machine. It is important that all personnel who are assigned to and responsible for the operation and maintenance of the machine undergo a thorough training program and check out period in order to become familiar with the characteristics prior to operating the machine.

Persons under the influence of drugs or alcohol or who are subject to seizures, dizziness or loss of physical control must not be permitted to operate the machine.

**b. Operator Training.**

Operator training must include instruction in the following:

- (1). Use and limitations of the platform controls, ground controls, emergency controls and safety systems.
- (2). Knowledge and understanding of this manual and of the control markings, instructions and warnings on the machine itself.
- (3). Knowledge and understanding of all safety work rules of the employer and of Federal, State and Local Statutes, including training in the recognition and avoidance of potential hazards in the work place; with particular attention to the work to be performed.
- (4). Proper use of all required personnel safety equipment.
- (5). Sufficient knowledge of the mechanical operation of the machine to recognize a malfunction or potential malfunction.
- (6). The safest means to operate near overhead obstructions, other moving equipment, obstacles, depressions, holes, dropoffs, etc. on the supporting surface.
- (7). Means to avoid the hazards of unprotected electrical conductors.
- (8). Any other requirements of a specific job or machine application.

**c. Training Supervision.**

Training must be done under the supervision of a qualified operator or supervisor in an open area free of obstructions until the trainee has developed the ability to safely control a sizzor lift in congested work locations.

**d. Operator Responsibility.**

The operator must be instructed that he has the responsibility and authority to shut down the machine in case of a malfunction or other unsafe condition of either the machine or the job site and to request further information from his supervisor or JLG Distributor before proceeding.

**Note**

**Manufacturer or Distributor will provide qualified persons for training assistance with first unit(s) delivered and thereafter as requested by user or his personnel.**

**3-3. OPERATING CHARACTERISTICS AND LIMITATIONS.****a. General.**

A thorough knowledge of the operating characteristics and limitations of the machine is always the first requirement for any user, regardless of user's experience with similar types of equipment.

**b. Placards.**

Important points to remember during operation are provided at the control stations by DANGER, WARNING, CAUTION, IMPORTANT and INSTRUCTION placards. This information is placed at various locations for the express purpose of alerting personnel of potential hazards constituted by the operating characteristics and load limitations of the machine. See foreword for definitions of the above placards.

**c. Capacities.**

Raising platform above horizontal with or without any load in platform, is based on the following criteria:

- (1). Machine is positioned on a smooth, firm and level surface.
- (2). Load is within manufacturer's rated capacity.
- (3). All machine systems are functioning properly.

**d. Stability.**

This machine, as originally manufactured by JLG and operated within its rated capacity on a smooth, firm and level supporting surface, provides a stable aerial platform for all platform positions.

FORM/GROUND SELECT or POWER SELECTOR switch supplies operating power to the platform or ground controls, as selected. When positioned to PLATFORM, the switch provides power to the platform controls. When positioned to GROUND, the switch provides power to the ground controls. With the PLATFORM/GROUND SELECT or POWER SELECTOR switch in the center off position, power is shut off to both platform and ground controls.

**Notes**

**With the PLATFORM/GROUND SELECT or POWER SELECTOR switch in the OFF position, the key can be removed in order to incapacitate the machine on the jobsite to avoid unauthorized use of the machine.**

**With the PLATFORM/GROUND SELECT or POWER SELECTOR switch positioned to GROUND, engine speed will stay in LOW at all times.**

**3-4. CONTROLS AND INDICATORS.**

Some machines may be equipped with control panels that use symbols instead of words to indicate control functions. Refer to Table 3-1 for these symbols and their corresponding functions.

**a. Ground Control Station. (Figure 3-1.)**

**WARNINGS**

**DO NOT OPERATE FROM GROUND CONTROL STATION WITH PERSONNEL IN THE PLATFORM EXCEPT IN AN EMERGENCY.**

**PERFORM AS MANY PRE-OPERATIONAL CHECKS AND INSPECTIONS FROM THE GROUND CONTROL STATION AS POSSIBLE.**

**Note**

**When the machine is shut down for overnight parking or battery charging, the BATTERY or EMERGENCY STOP switch must be positioned to OFF to prevent draining the batteries.**

- (1). BATTERY Switch.  
(CM1432/CM1432 Plus/CM1732)  
EMERGENCY STOP Switch.  
(CM2033/CM2046/CM2546/CM2558)  
  
A two-position, lever operated BATTERY or EMERGENCY STOP switch, when positioned to ON, furnishes operating power to the PLATFORM/GROUND SELECT or POWER SELECTOR switch.
- (2). PLATFORM/GROUND SELECT Switch.  
(CM1432/CM1432 Plus/CM1732)  
POWER SELECTOR Switch.  
(CM2033/CM2046/CM2546/CM2558)  
  
A three position, key-operated PLAT-

(3). Lift Switch.

A three position, momentary contact LIFT control switch provides raising and lowering of the platform when positioned to UP or DOWN.

(4). Circuit Breaker.

A push button reset 15 Amp circuit breaker, located at the ground control panel, returns interrupted power to the machine functions when depressed.

(5). Ammeter.

The ammeter is used to show the output of the battery charger when the charger is in operation.

**b. Platform Control Station.  
(Figures 3-2, 3-3, 3-4, and 3-5.)**

(1). Enable Switch.

Some machines built before August 1992 and all machines built after August 1992 are equipped with an ENABLE switch on the side of the platform control box. The ENABLE switch must be pressed before activating the DRIVE, LIFT or STEER functions. A built-in timer shuts off power to these functions if they are not activated within 3 seconds after the ENABLE switch is depressed. In addition, this timer will shut off power to the DRIVE and LIFT functions 3 seconds after they are deactivated, making it necessary to depress the ENABLE switch before activating DRIVE or LIFT again. The STEER function, unless activated in conjunction with the DRIVE or LIFT functions, will automatically cut off after 3 seconds of operation.



- (2). Emergency Stop Switch.

An EMERGENCY STOP switch is provided in order to turn machine power on and off in the platform and also to turn off machine power in the event of an emergency. Power is turned on by pulling the switch up (ON), and is turned off by pushing the switch down (OFF).

- (3). Tilt Alarm Warning Horn.

The Tilt Alarm Warning Horn is activated by the Tilt Alarm Switch when the chassis is on a severe slope (over 3 degrees).

**CAUTION**

**IF TILT ALARM IS ON WHEN PLATFORM IS RAISED, LOWER PLATFORM COMPLETELY, THEN REPOSITION MACHINE SO THAT IT IS LEVEL BEFORE RAISING PLATFORM.**

- (4). Tilt Alarm Warning Light. (Red)

A warning light on the control console that lights when the chassis is on a severe slope (over 3 degrees).

**Note**

The LIFT, DRIVE, and STEER toggle switches automatically return to the center OFF position when released.

**WARNING**

**TO AVOID SERIOUS INJURY, DO NOT OPERATE MACHINE IF LIFT, DRIVE, OR STEER TOGGLE SWITCHES DO NOT RETURN TO THE CENTER OFF POSITION WHEN RELEASED.**

- (5). Lift Switch.

The LIFT toggle switch provides for raising and lowering the platform when positioned to UP or DOWN.

**CAUTION**

**IF MACHINE IS EQUIPPED WITH OPTIONAL PLATFORM EXTENSION, DO NOT "LIFT DOWN" WITHOUT COMPLETELY RETRACTING PLATFORM EXTENSION. MACHINES BUILT TO FRENCH AND ITALIAN SPECIFICATIONS CUT OUT "LIFT DOWN" WHEN PLATFORM EXTENSION IS EXTENDED.**

- (6). Positive Traction Switch.

This push button switch, when depressed, activates a solenoid on the main control valve, forcing oil through a flow divider in the drive circuit, maintaining hydraulic oil flow to both drive motors for improved traction.

- (7). Steer Switch. (w/o PQ Controller)

The Steer Switch is a three position, center off toggle switch that enables steering the machine to the right or left.

- (8). Drive Control Switch. (w/o PQ Controller)

The Drive Control Switch is a three position, center off toggle switch that enables the machine to travel in FORWARD or REVERSE.

- (9). Drive Motor Speed Switch. (w/o PQ Controller)

A two position Drive Motor Speed Switch allows additional oil flow to the drive circuit when positioned to HIGH. Machines built after January 1993 will incorporate a three position switch to give the operator an additional drive speed.

**Note**

**The Drive Motor Speed Switch will cut-out when platform is raised above stowed position, leaving only low speed available until platform is lowered completely.**

**CAUTION**

**DO NOT OPERATE MACHINE IF HIGH DRIVE SPEED OPERATES WHEN PLATFORM IS RAISED ABOVE THE STOWED POSITION.**

- (10). PQ Controller. (If Equipped.)

The PQ Controller performs three functions: Drive, Steer and Drive Speed. Tilting the controller in the direction you want to go (forward or reverse) activates drive in that direction. The thumb-operated steer switch on top of the controller handle activates the steer wheels in the direction it is moved. Drive speed is determined by distance the controller handle is moved forward or backward.

- (11). Horn. (If Equipped.)

This push-button switch, when activated, permits the operator to warn jobsite personnel when the machine is operating in the area.

- (12). Battery Condition Indicator/Hourmeter. (If Equipped.)

The battery condition indicator is a gauge that provides a visual indication of the condition of the batteries, and also includes an hourmeter to indicate the number of hours the machine has been operated.

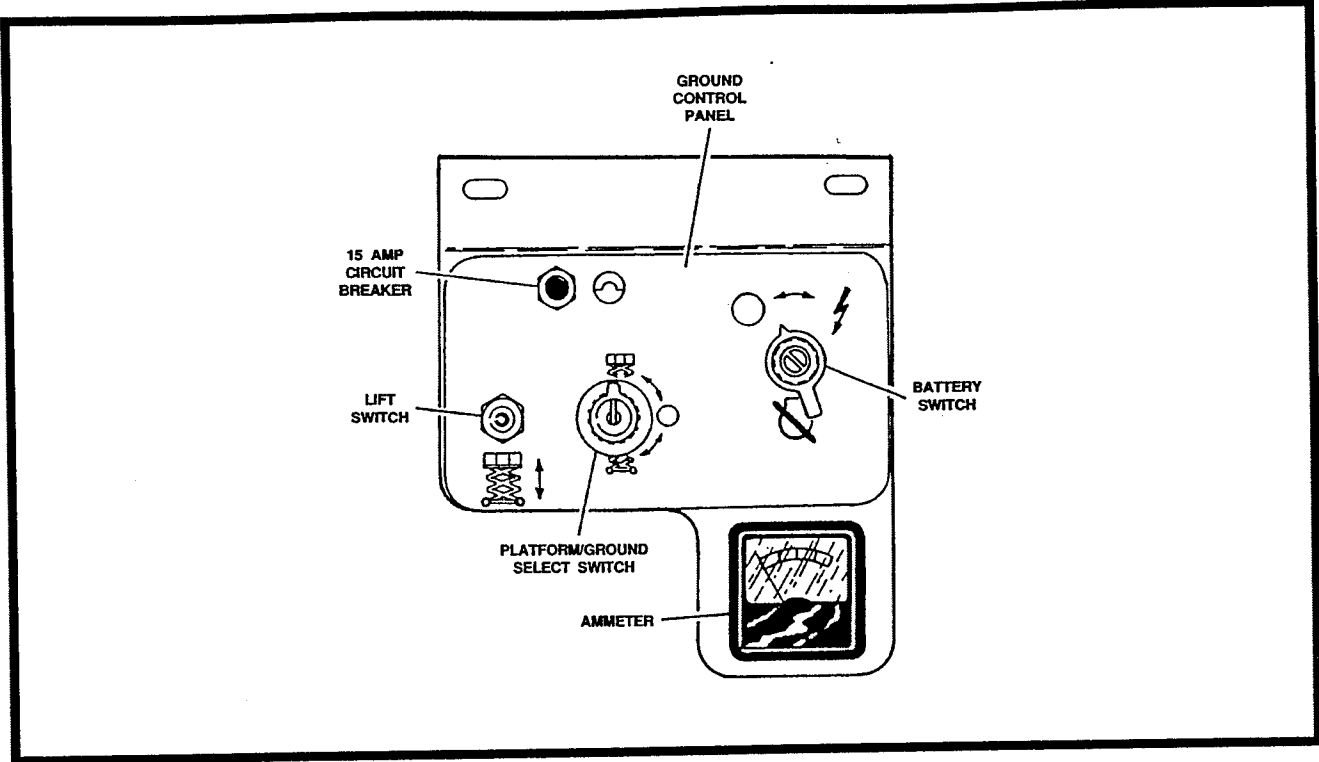

Figure 3-1. Ground Control Station - CM1432/CM1432 Plus/CM1732.

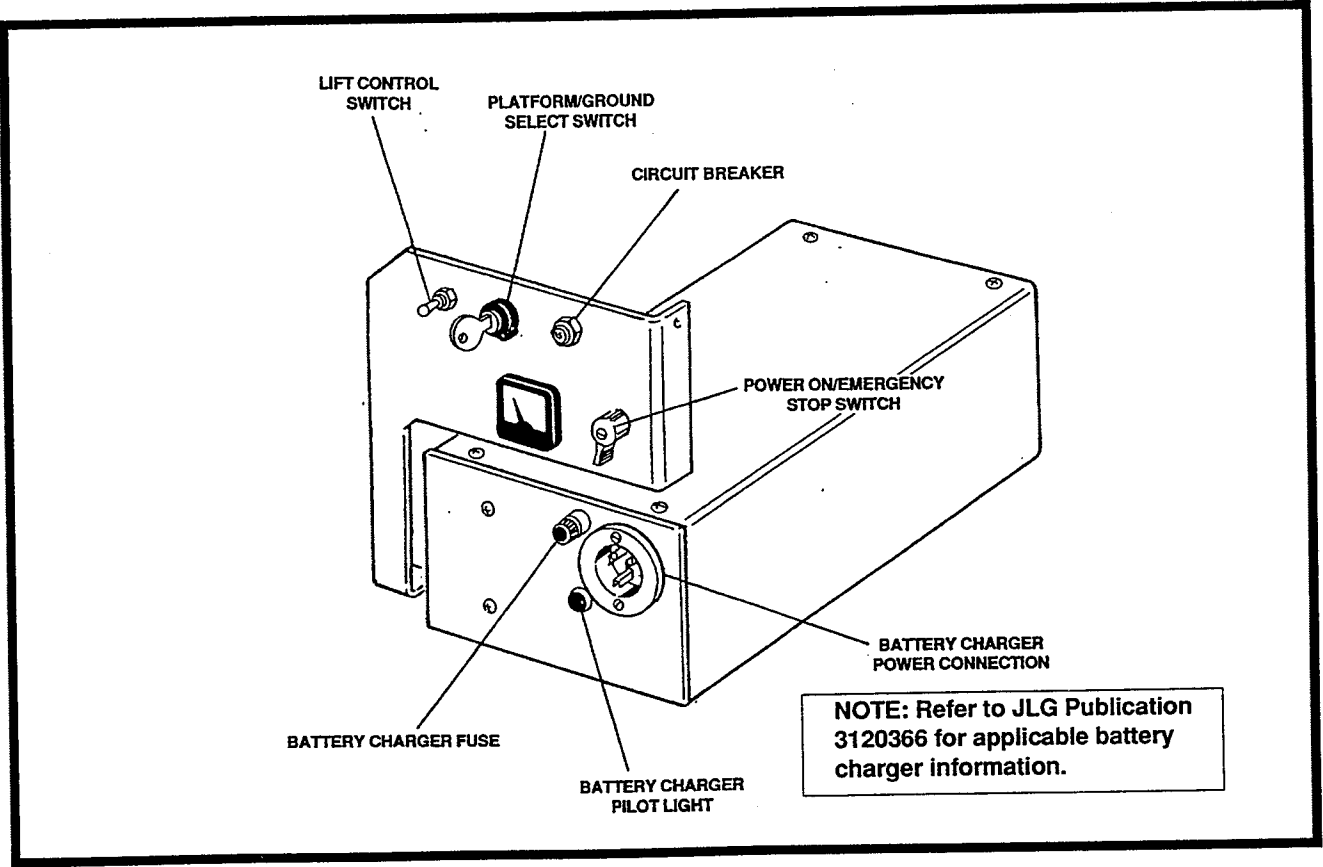

Figure 3-2. Ground Control Station - CM2033/CM2046/CM2546/CM2558.

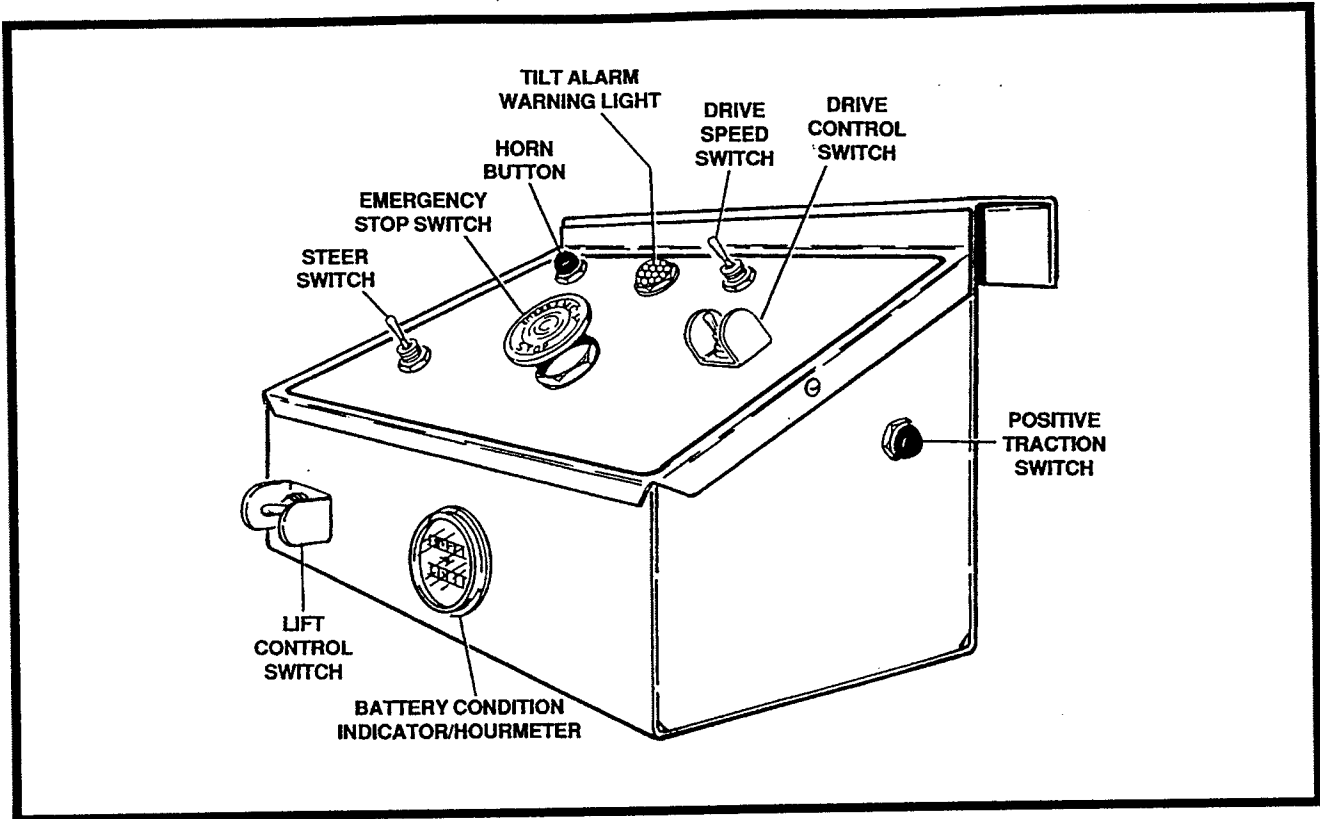

Figure 3-3. Platform Control Station w/o PQ Controller - All Models - Machines Built Before August 1992.

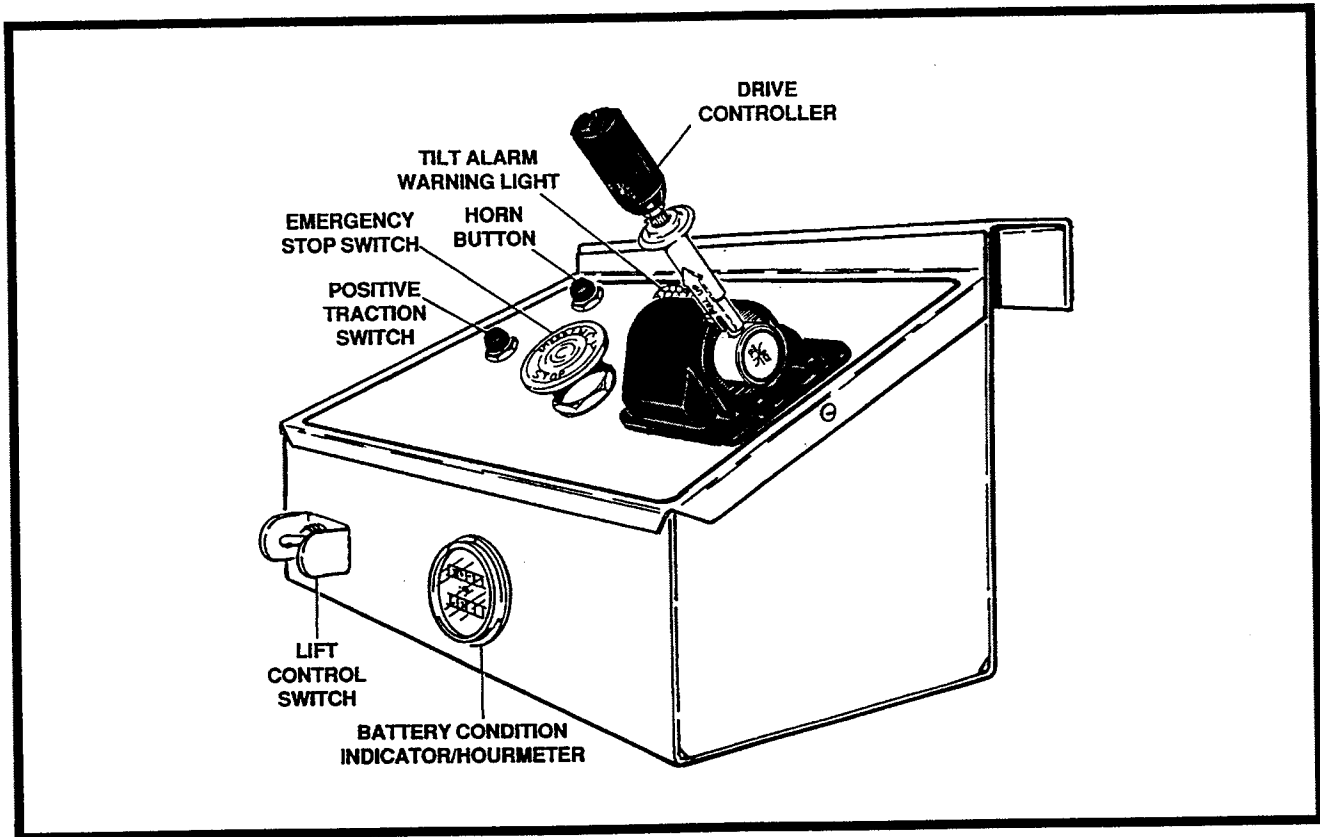

Figure 3-4. Platform Control Station w/PQ Controller - All Models - Machines Built Before August 1992.

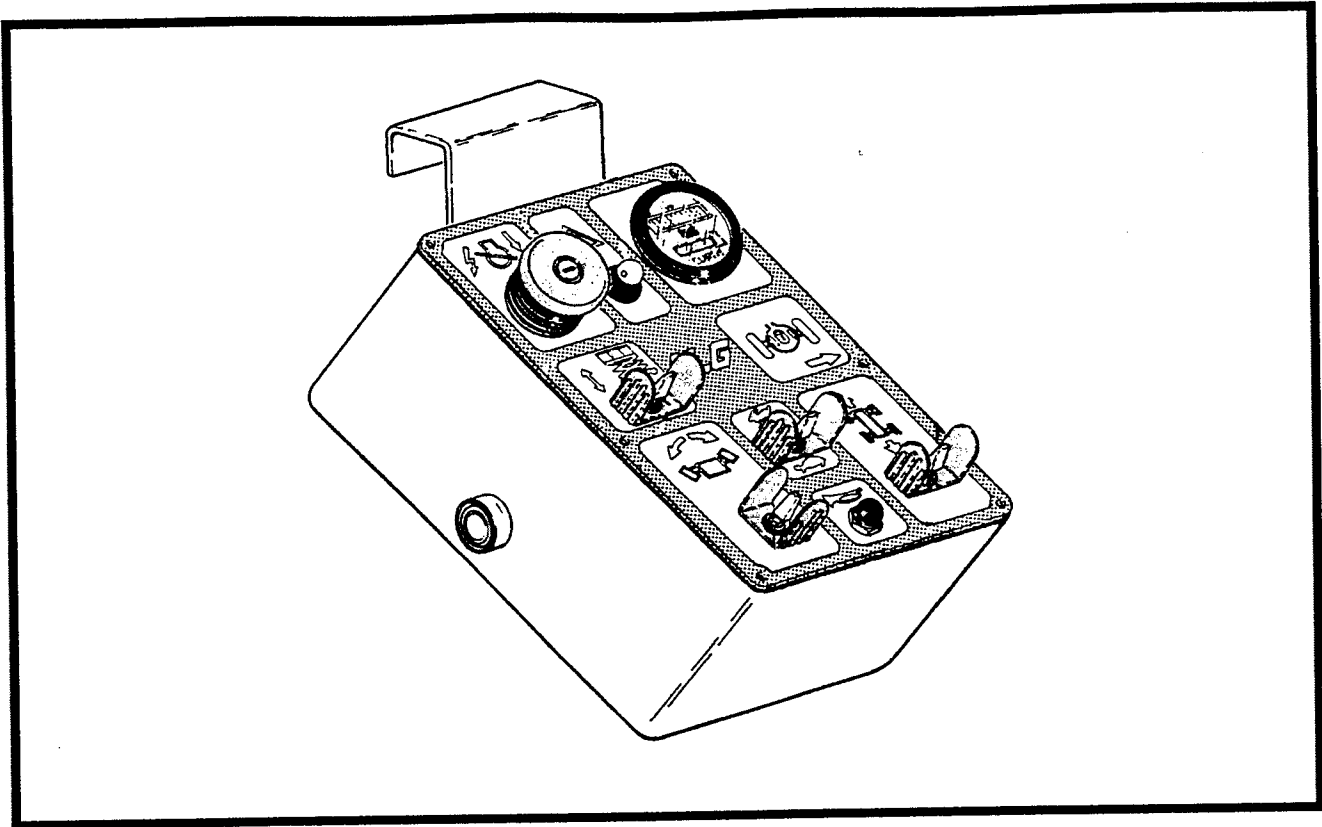

Figure 3-5. Platform Control Station w/o PQ Controller - All Models - Machines Built After August 1992.

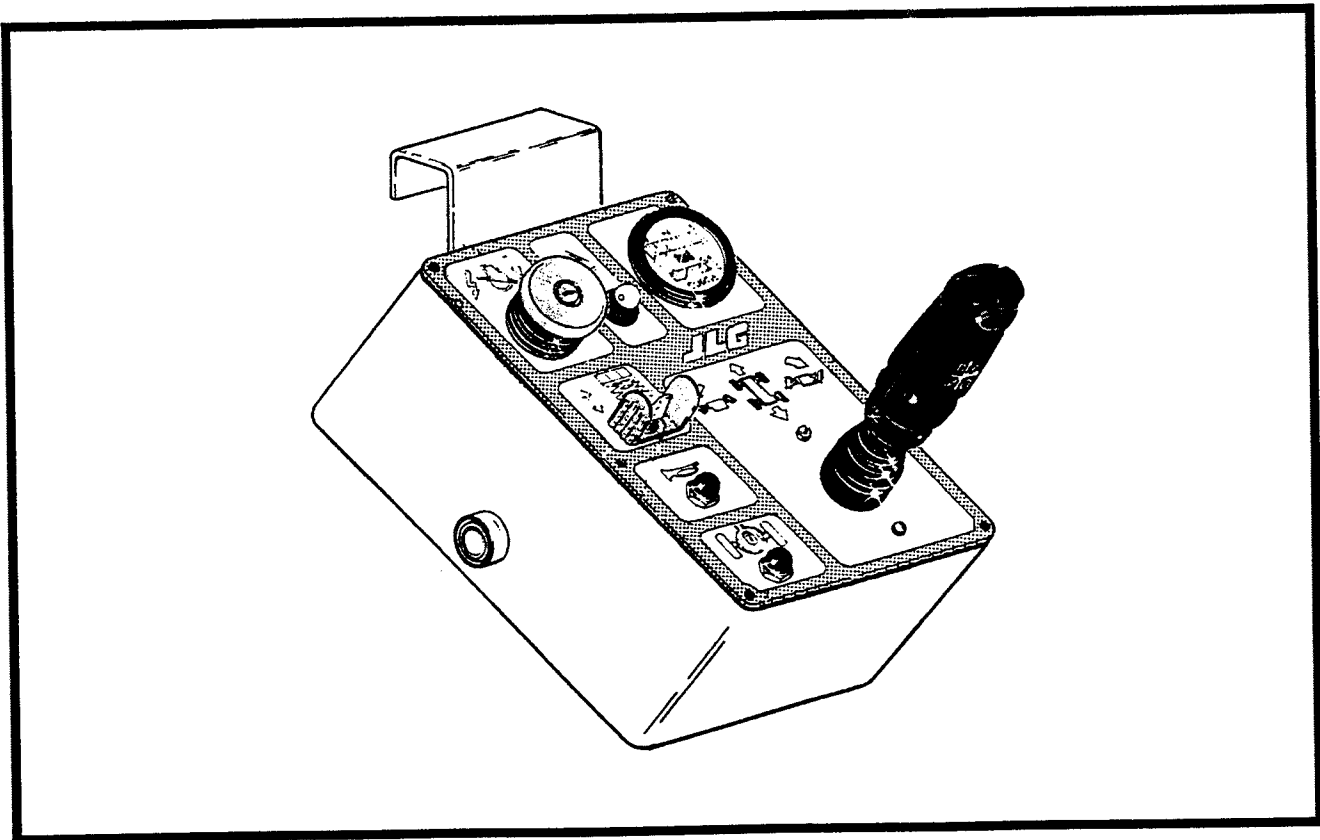

Figure 3-6. Platform Control Station w/PQ Controller - All Models - Machines Built After August 1992.

Table 3-1. Control Panel Symbols. (Sheet 1 of 3)













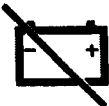







FUNCTION	SYMBOL	FUNCTION	SYMBOL
AUXILIARY POWER		DUAL FUEL	
BATTERY DISCONNECT		ELECTRICAL HAZARD	
CAUTION		EMERGENCY SHUT-OFF	
CAUTION		EMERGENCY SWITCH DOWN	
CHOKE		EMERGENCY SWITCH UP	
CIRCUIT BREAKER		ENGINE SPEED	
COLD START		EXPLOSION HAZARD	
CREEP		EXTENDABLE PLATFORM CAPACITY	
CRUSHING		FACTORY MUTUAL APPROVED	
DANGER		FAN	
DRIVE		FAST	
DRIVE CUT-OUT		FIXED PLATFORM CAPACITY	

Table 3-1. Control Panel Symbols. (Sheet 2 of 3)

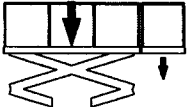



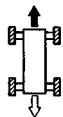

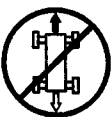
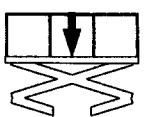



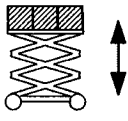

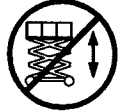



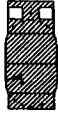

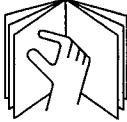

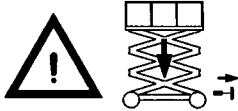

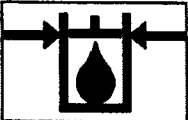
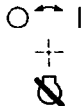



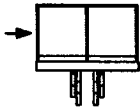

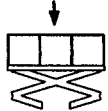
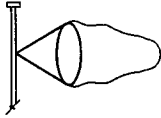

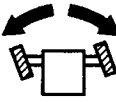

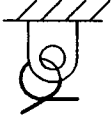
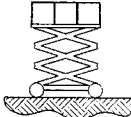

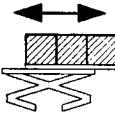

FUNCTION	SYMBOL	FUNCTION	SYMBOL
FUEL		LIFT	
FUNCTION ENABLE		LIFT CUT-OUT	
HAND CRUSHING HAZARD		LIFTING AREA	
HIGH ENGINE SPEED		LP GAS	
HORN		MANUAL	
HYDRAULIC OIL		MANUAL DESCENT	
HYDRAULIC OIL LEVEL (LOW)		MANUAL DESCENT KNOB	
HYDRAULIC OIL LEVEL (HIGH)		MASTER SWITCH	
IGNITION		MASTER SWITCH OFF	
IMPORTANT (SAFETY INSTRUCTIONS)		MAXIMUM PERMISSIBLE PLATFORM SIDE LOAD	
INDOOR USE ONLY		MAXIMUM PLATFORM LOAD	

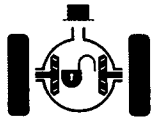
Table 3-1. Control Panel Symbols. (Sheet 3 of 3)

FUNCTION	SYMBOL	FUNCTION	SYMBOL
MAXIMUM WIND SPEED		SLOW	
NO LIFTING AREA		STEER	
NO TIE DOWN AREA		TIE DOWN AREA	
PLATFORM ELEVATED DRIVE ON SMOOTH LEVEL SURFACE		TILT	
PLATFORM/GROUND SELECT		TWO WHEEL DRIVE/FOUR WHEEL DRIVE	
PLATFORM TRAVERSE		TRAVERSING PLATFORM/CAPACITY	
POSITIVE TRACTION DISENGAGED		"UL" DOUBLE E RATED	
POSITIVE TRACTION ENGAGED		WARNING	
RESTRICTED DRIVE ON ROUGH TERRAIN		WHEEL SPEED	
RESTRICTED DRIVE ON SLOPE		WORK LIGHTS	

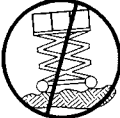



#### 4-1. DESCRIPTION.

This machine is a self-propelled aerial work platform on top of an elevating 'sizzor' mechanism. The Sizzor Lift's intended purpose is to position personnel with their tools and supplies at positions above ground level. The machine can be used to reach work areas located above machinery or equipment positioned at ground level.

The JLG Sizzor Lift has a primary operator Control Station in the platform. From this Control Station, the operator can drive and steer the machine in both forward and reverse directions as well as raise and lower the platform. The machine has a Ground Control Station which will override the Platform Control Station. Ground Controls operate lift up and down and are to be used only in an emergency to lower the platform to the ground should the operator in the platform be unable to do so.

Instructions and hazard warnings are posted adjacent to both operator control stations and at other places on the machine. It is extremely important that operators know what instructions and warnings are placed on the machine, and review these periodically so that they are fresh in their minds.

The JLG Sizzor Lift is designed to provide efficient and safe operation when maintained and operated in accordance with warnings on the machine, the Operating and Safety Manual, the Service and Maintenance Manual and all jobsite and government rules and regulations. As with any type of machinery, the operator is very important to efficient and safe operation. It is absolutely necessary that the JLG Lift be regularly maintained in accordance with this manual and the machine Service and Maintenance Manual, and that any evidence of lack of maintenance, malfunction, excessive wear, damage or modification to the machine be reported immediately to the machine owner or the jobsite supervisor or safety manager and that the machine be taken out of service until all discrepancies are corrected.

The JLG Sizzor Lift is not intended to be used to lift material other than supplies which personnel in the platform require to do their job. Supplies or tools which extend outside the platform are prohibited. It must not be used as a forklift, crane, support for overhead structure, or to push or pull another object.

The JLG Sizzor Lift is powered using hydraulic motors and cylinders for the various machine motions. The hydraulic components are controlled by electrically activated hydraulic valves using switches and control levers. The speeds of functions controlled by control levers are variable from zero to maximum speed depending upon the position of the control lever. Functions controlled by

toggle switches are either on or off and higher or lower speed is possible only when the applicable high function speed control switch at the Platform Control Station is used in conjunction with the function toggle switch.

The JLG Sizzor is a two wheel drive machine with drive power being supplied by a hydraulic motor for each drive wheel. The rear wheels are supplied with hydraulically applied and released brakes. These brakes are automatically applied any time the Drive control is returned to the neutral position.

The capacity of models CM1432 and CM1732 is 225 kilograms, the capacity of model CM1432 Plus is 272 kilograms, the capacity of models CM2033 and CM2546 is 340 kilograms and the the capacity of models CM2546 and CM 2558 is 454 kilograms, uniformly distributed in the center of the platform. The capacity of the platform extension is 113 kilograms. This means that the total combined weight of personnel, tools and supplies must not exceed the above figures.

The platform may be raised only when positioned on firm, level and uniform surfaces.

#### 4-2. GENERAL.

This section provides the necessary information needed to operate the machine. Included in this section are the procedures for starting, stopping, traveling, steering, parking, platform loading and transporting. It is important that the user read and understand the proper procedures before operating the machine.

#### 4-3. MOTOR OPERATION.

- a. **Battery Switch.**  
(CM1432/CM1432 Plus/CM1732)  
**Emergency Stop Switch.**  
(CM2033/CM2046/CM2546/CM2558)

This switch, when in the ON position, provides battery power to the Platform/Ground Select switch or Power Selector switch for all machine functions. The switch should be in the OFF position when recharging the batteries and/or parking the machine overnight.

- b. **Platform/Ground Select Switch.**  
(CM1432/CM1432 Plus/CM1732)  
**Power Selector Switch.**  
(CM2033/CM2046/CM2546/CM2558)

The Platform/Ground Select switch or Power Selector switch functions to direct battery power to the desired control station. With the switch in the GROUND position, battery power is supplied to the ground control station. When the switch is in the PLATFORM position, battery power is supplied to the platform control station.

**Note**

Some machines built before August 1992 and all machines built after August 1992 are equipped with an ENABLE switch on the platform control box. This switch must be depressed before activating DRIVE, LIFT, or STEER functions from the platform control box.

**c. Motor Activation.**

With the Battery or Emergency Stop switch in the ON position, the Platform/Ground Select switch or Power Selector switch in the appropriate position, the platform Emergency Stop switch in the ON position (if operator is at platform controls) and a function switch is operated and held, the motor becomes activated and operates the desired function.

**CAUTION**

**IF A MOTOR MALFUNCTION NECESSITATES UNSCHEDULED SHUTDOWN, DETERMINE AND CORRECT CAUSE BEFORE RESUMING ANY OPERATION.**

**IMPORTANT**

**ALWAYS POSITION EMERGENCY STOP SWITCH TO THE 'OFF' POSITION WHEN MACHINE IS NOT IN USE. FAILURE TO DO SO MAY CAUSE UNNECESSARY DRAINAGE OF POWER FROM BATTERIES.**

**4-4. RAISING AND LOWERING. (Lifting)****WARNINGS**

**DO NOT RAISE PLATFORM EXCEPT ON A HARD, LEVEL SURFACE FREE OF OBSTRUCTIONS AND HOLES.**

**THE MACHINE IS EQUIPPED WITH A 3 DEGREES TILT SWITCH THAT ILLUMINATES A LIGHT ON THE PLATFORM CONTROL CONSOLE AND SOUNDS AN AUDIBLE ALARM WHEN THE MACHINE IS ON A SEVERE SLOPE (OVER 3 DEGREES) WITH THE PLATFORM RAISED. TO TURN OFF AUDIBLE ALARM, LOWER PLATFORM COMPLETELY TO STOWED POSITION. WHEN THE MACHINE IS ON A SEVERE SLOPE (OVER 3 DEGREES) WITH THE PLATFORM COMPLETELY LOWERED, ONLY THE WARNING LIGHT IS ILLUMINATED.**

**MACHINES BUILT TO FRENCH SPECIFICATIONS CUT OUT DRIVE FORWARD AND REVERSE AND LIFT UP FUNCTION WHEN MACHINE IS ON A SEVERE SLOPE (OVER 3 DEGREES) WITH THE PLATFORM RAISED.**

**Note**

Some machines built before August 1992 and all machines built after August 1992 are equipped with an ENABLE switch on the side of the platform control box. This switch must be depressed before activating DRIVE, LIFT, or STEER functions from the platform control box.

**a. Raising.**

- (1). If machine is shut down, turn Emergency Stop Switch to ON position.
- (2). Place Power Selector switch to appropriate position.
- (3). Position Lift switch to UP and hold until desired elevation is achieved. If equipped, depress Enable switch before activating LIFT UP function.

**b. Lowering.****WARNING**

**ENSURE SIZZOR ARM AREA IS FREE OF PERSONNEL PRIOR TO LOWERING PLATFORM.**

Position Lift switch to DOWN and hold until desired elevation is achieved or until platform is fully lowered. If equipped, depress Enable switch before activating LIFT DOWN function.

**WARNING**

**IF MACHINE IS EQUIPPED WITH OPTIONAL EXTENDING PLATFORM, DO NOT 'LIFT DOWN' WITHOUT COMPLETELY RETRACTING EXTENDING PLATFORM.**

**4-5. PLATFORM EXTENSION. (If Equipped.)**

The machine may be equipped with a mechanically extendable deck, which adds 1 meter to the front of the platform, giving the operator better access to worksites. To extend the deck, squeeze the release lever on the handle on the left side of the platform to release the latch and use the handle to push the extendable deck out. When the deck reaches the end of its travel, the latch will lock to hold the deck in place. To retract the deck, squeeze the release lever to release the latch and use the handle to retract the deck. Be sure the latch locks the deck in place after it is retracted. Maximum capacity of the deck extension is 113 kilograms.

**WARNING**

**MACHINES BUILT TO FRENCH AND ITALIAN SPECIFICATIONS CUT OUT "LIFT DOWN" FUNCTION WHEN PLATFORM EXTENSION IS EXTENDED. PLATFORM EXTENSION MUST BE FULLY RETRACTED TO RESTORE "LIFT DOWN" FUNCTION.**

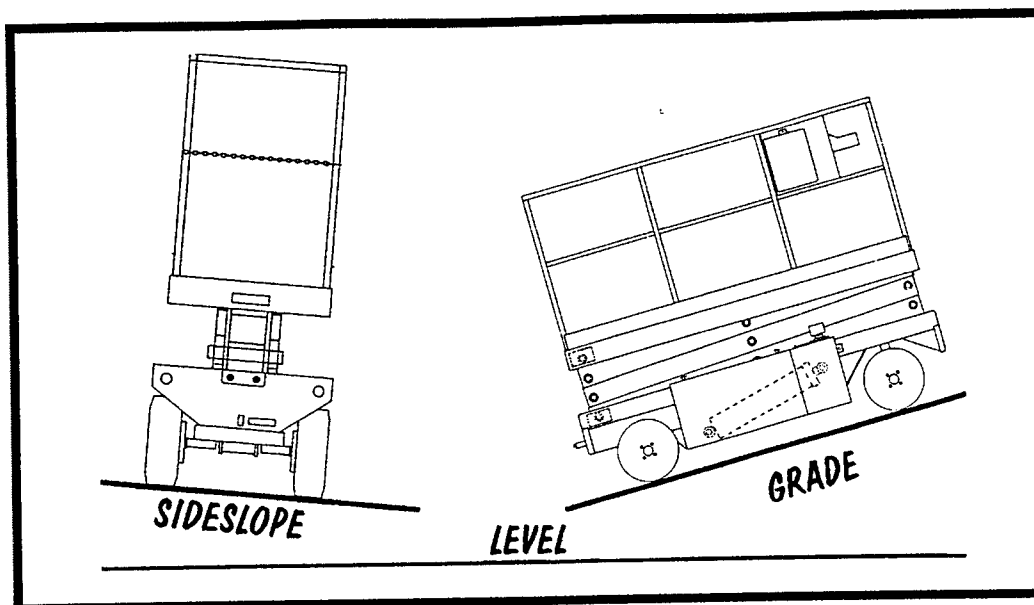

Figure 4-1. Grade and Sideslope.

## 4-6. STEERING.

## Note

Some machines built before August 1992 and all machines built after August 1992 are equipped with an **ENABLE** switch on the side of the platform control box. This switch must be depressed before activating **DRIVE**, **LIFT**, or **STEER** functions from the platform control box.

## a. Toggle Switch Operated - w/o PQ Controller.

To steer the machine, the **STEER** toggle switch is positioned to the right for traveling right, or to the left for traveling left. If machine is equipped with an **Enable** switch, **Enable** switch must be depressed before activating **STEER** function.

When released, the switch will return to the center-off position and the wheels will remain in the previously selected position. To return the wheels to the straightened position, the switch must be activated in the opposite direction until the wheels are centered.

## b. Thumb Operated - w/PQ Controller.

To steer the machine, the thumb operated steer control switch on the controller handle is positioned to the right for traveling right, or to the left for traveling left. If machine is equipped with an **Enable** switch, **Enable** switch must be depressed before activating **STEER** function.

When released, the switch will return to the center-off position and the wheels will remain in the previously selected position. To return the wheels to the straightened position, the switch must be activated in the opposite direction until the wheels are centered.

## 4-7. TRAVELING. (Driving) (See Figure 4-1.)

## WARNINGS

**DO NOT DRIVE WITH PLATFORM RAISED EXCEPT ON A SMOOTH, FIRM AND LEVEL SURFACE FREE OF OBSTRUCTIONS AND HOLES.**

**TO AVOID LOSS OF TRAVEL CONTROL OR UPSET ON GRADES AND SIDESLOPES, DO NOT DRIVE MACHINE ON GRADES OR SIDESLOPES EXCEEDING THOSE SPECIFIED ON CAUTION PLACARD AT PLATFORM.**

**TRAVEL GRADES IN "LOW" DRIVE SPEED ONLY. USE EXTREME CAUTION WHEN DRIVING IN REVERSE AND AT ALL TIMES WHEN DRIVING WITH PLATFORM ELEVATED AND ESPECIALLY WHEN DRIVING WITH ANY PART OF MACHINE WITHIN 1.8 METERS OF AN OBSTRUCTION.**

**MACHINE IS EQUIPPED WITH A 3 DEGREES TILT SWITCH THAT ILLUMINATES A LIGHT ON THE PLATFORM CONTROL CONSOLE AND SOUNDS AN AUDIBLE ALARM WHEN THE MACHINE IS ON A SEVERE SLOPE (OVER 3 DEGREES). TO TURN OFF ALARM, LOWER PLATFORM COMPLETELY TO STOWED POSITION. WHEN THE MACHINE IS ON A SEVERE SLOPE (OVER 3 DEGREES) WITH THE PLATFORM COMPLETELY LOWERED, ONLY THE WARNING LIGHT IS ILLUMINATED.**

**Note**

Some machines built before August 1992 and all machines built after August 1992 are equipped with an ENABLE switch on the side of the platform control box. This switch must be depressed before activating DRIVE, LIFT, or STEER functions from the platform control box.

**a. Traveling Forward.**

- (1). If machine is shut down, turn Battery or Emergency Stop switch at ground control station to ON position.
- (2). Place Platform/Ground Select or Power Selector switch at ground control station to PLATFORM.
- (3). If machine is not equipped with a PQ controller, position Drive Motor Speed switch to desired position and position Drive switch to FORWARD and hold for duration of travel. If machine is equipped with Enable switch, Enable switch must be depressed before activating DRIVE function.
- (4). If machine is equipped with a PQ controller, position control handle to FORWARD and hold for duration of travel. Drive speed is determined by the distance the control handle is moved from the center off position. If machine is equipped with Enable switch, Enable switch must be depressed before activating DRIVE function.

**b. Traveling in Reverse.**

- (1). If machine is shut down, turn Battery or Emergency Stop switch at ground control station to ON position.
- (2). Place Platform/Ground Select or Power Selector switch at ground control station to PLATFORM.
- (3). If machine is not equipped with a PQ controller, position Drive Motor Speed switch to desired position and position Drive switch to REVERSE and hold for duration of travel. If machine is equipped with Enable switch, Enable switch must be depressed before activating DRIVE function.
- (4). If machine is equipped with a PQ controller, position control handle to REVERSE and hold for duration of travel. Drive speed is determined by the distance the control handle is moved from the center off position. If machine is equipped with Enable

switch, Enable switch must be depressed before activating DRIVE function.

**4-8. PARKING AND STOWING.****Note**

When parking units overnight, batteries should be charged in accordance with instructions in Section 2 to ensure readiness for the following workday.

Park and stow machine as follows:

- a. Drive machine to a reasonably well-protected and well-ventilated area.
- b. Ensure platform is fully lowered.
- c. Position Battery or Emergency Stop switch to OFF position.
- d. If necessary, cover the instruction placards, caution and warning decals so that they will be protected from hostile environment.
- e. Chock at least two wheels when parking machine for an extended period of time.
- f. Turn Platform/Ground Select or Power Selector switch to OFF and remove key to disable machine from unauthorized use.

**4-9. PLATFORM LOADING.****WARNING**

**MACHINES BUILT TO FRENCH SPECIFICATIONS CUT OUT DRIVE AND LIFT FUNCTIONS WHEN MACHINE IS LOADED TO 120% OF RATED CAPACITY. IN ADDITION, AN AUDIBLE ALARM IS SOUNDED WHEN THIS CONDITION EXISTS. TO TURN OFF ALARM AND RESTORE FUNCTIONS, REMOVE WEIGHT FROM PLATFORM UNTIL FUNCTIONS ARE RESTORED AND ALARM IS SILENCED.**

- a. The platform maximum rated load capacity is shown on a placard located on the platform and is based upon the following criteria.
  - (1). Machine is positioned on a smooth, firm and level surface.
  - (2). All braking devices are engaged.
  - (3). Maximum capacity for each model is as follows:

CM1432 - 230 kilograms  
 CM1432 Plus - 270 kilograms  
 CM1732 - 225 kilograms  
 CM2033 - 340 kilograms  
 CM2046 - 454 kilograms  
 CM2546 - 340 kilograms  
 CM2558 - 454 kilograms

- (4). Maximum capacity of platform extension is 113 kilograms.
- b. It is important to remember that the load should be evenly distributed on the platform. The load should be placed near the center of the platform when possible.

#### 4-10. SAFETY PROP.

##### CAUTION

**SAFETY PROP MUST BE USED WHEN MAINTENANCE PERFORMED ON MACHINE REQUIRES SIZZOR ARMS TO BE RAISED.**

- a. To engage safety prop, raise platform, then rotate prop clockwise until it hangs vertically. Lower the platform until the safety prop rests on the point provided on the frame. Maintenance can now begin.
- b. To store safety prop, raise platform so that prop can be rotated counterclockwise until it rests on the stop provided on the sizzor arms. Ensure safety prop is latched in place.

#### 4-11. TIE DOWN AND LIFTING.

##### a. Tie Down.

When transporting machine, platform must be fully retracted in the stowed mode with machine securely tied down to truck or trailer deck. On models CM1432, CM1432 Plus, CM1732, and CM2033, three tie down eyes, one at the front of the frame and two at the rear of the frame, are provided. On models CM2046, CM2546, and CM2558, four tie down eyes are provided in the frame, two at the front of the frame and two at the rear of the frame.

##### WARNING

**USE TIE DOWN EYES ONLY TO SECURE THE MACHINE FOR SHIPPING. DO NOT USE TIE DOWN EYES TO LIFT MACHINE.**

##### b. Lifting.

If it becomes necessary to lift the machine, a pair of forklift tubes are provided at the rear of the machine. It is very important that the forklift operator use only the designated lifting tubes to lift the machine.

##### Note

**Forklifts must be capable of handling the following weights: CM1432 and CM1432 Plus - 907 kilograms, CM1732 - 991 kilograms, CM2033 - 1,497 kilograms, CM2046 - 1,633 kilograms, CM2546 - 1,950 kilograms, CM2558 - 2,087 kilograms.**

The machine may also be equipped with a lifting lug at each corner of the frame. With proper lifting equipment, these lugs may be used in lieu of the forklift tubes to lift the machine.

#### 4-12. TOWING.

It is not recommended that this machine be towed, except in the event of an emergency such as a machine malfunction or a total machine power failure. Refer to Section 6 for emergency towing procedures.



**5-1. PQ CONTROLLER.**

A "multiple-step" controller is available which operates STEER and DRIVE from a single control handle.

**5-2. PLATFORM EXTENSION.**

The mechanically extendable deck adds 1 meter to the front of the platform, giving the operator better access to worksites. Maximum capacity of the platform extension is 165 kilograms.

**5-3. HORN.**

The warning horn is located on the frame of the machine, and is controlled by a push button switch on the platform control console. The warning horn permits the operator to warn jobsite personnel when the machine is operating in the area.

**5-4. TRAVEL ALARM.**

The travel alarm horn, mounted on the frame of the machine, provides an audible warning when the machine is in the travel (DRIVE) mode. It will function in FORWARD or REVERSE to warn jobsite personnel the machine is traveling.

**5-5. MOTION ALARM.**

The motion alarm horn, mounted on the frame of the machine, provides an audible warning when the machine is in the travel (DRIVE) or LIFT mode. It will function in FORWARD, REVERSE, LIFT UP or LIFT DOWN to warn jobsite personnel the machine is traveling or lifting.

**5-6. DESCENT ALARM.**

Produces an audible warning when platform LIFT control is placed in the LIFT DOWN position. The alarm warns personnel in the jobsite area to avoid the sizzor arms.

**5-7. PLATFORM WORK LIGHTS.**

The two platform work lights are installed on the platform rails to provide additional lighting for the operator. Each light is equipped with an on-off switch.

**5-8. FOAM-FILLED TIRES.  
(CM2046 and CM2558 Only.)**

These tires provide stability and eliminate flats by filling the tubes with polyurethane foam. For use where sharp objects are frequently encountered on the jobsite.

**5-9. NON-MARKING TIRES.**

For indoor use, these tires are made from a special compound that, unlike regular tires, will not leave black skid marks on floors and other surfaces.

**5-10. ROTATING BEACON.**

An amber rotating beacon is installed on the machine platform rail. When the machine power is turned on, the light is activated and provides a visual warning to the machine's operation.

**5-11. HIGH OUTPUT BATTERIES.  
(CM2046, CM2546 and CM2558 Only.)**

For increased operating power and reserve capacity, 370 Amp Hour batteries are available in place of the standard 245 Amp Hour batteries.

**5-12. BATTERY CONDITION INDICATOR.**

The battery condition indicator is a gauge that provides a visual indication of the condition of the batteries, and also includes an hourmeter to indicate the number of hours the machine has been operated.

**5-13. FOLD-DOWN HAND RAILS.**

The fold-down handrails enable the operator to take the machine into areas where platform height may pose a clearance problem. The fold-down hand rails give the operator an additional 27 centimeters clearance.

**5-14. CONTROL BOX COVER.  
(Standard Toggle Switch Controls Only.)**

A hinged metal cover on the platform control box, which can be pinned in place to cover the platform controls when the machine is not in use. When the pin is removed, the cover can be flipped out of the way for machine operation.

**5-15. LIFTING LUGS.**

The machine may be equipped with lifting lugs, welded to the four corners of the machine frame. These lugs enable the machine to be lifted using chains or other suitable lifting devices.

**5-16. PLATFORM ACCESS DOOR.**

A hinged, latching door at the aft end of the platform replaces the standard drop bar gate, giving the operator easier access to the platform.





**6-1. GENERAL.**

This section provides information on the procedures to be followed and on the systems and controls to be used in the event an emergency situation is encountered during machine operation. Prior to operation of the machine and periodically thereafter, the entire operating manual, including this section, should be reviewed by all personnel whose responsibilities include any work or contact with the machine.

**6-2. EMERGENCY TOWING PROCEDURES.**

a. Although towing the machine is prohibited, provisions for moving the machine, in case of a malfunction or power failure, have been incorporated. The following procedures are to be used **ONLY** for emergency movement to a suitable maintenance area.

- (1). Chock wheels securely.
- (2). Turn free-wheeling valve knob on main control valve counterclockwise all the way out.
- (3). If machine is equipped with handle type parking brake (CM2033, CM2046, CM2546, and CM2558 built prior to March 1992), pull parking brake handle to release parking brake and attach handle to hook on machine frame.
- (4). If machine is equipped with hydraulically operated parking brake (CM1432, CM1432 Plus, CM1732; and CM2033, CM2046, CM2546, and CM2558 built after March 1992), release parking brake as follows:
  - (a). Using a suitably sized wrench, move brake cam to horizontal position.
  - (b). Repeat step (a) for remaining brake cylinder.
- (5). Using suitable equipment for assistance, remove chocks, and move machine to an appropriate maintenance area.

b. After moving machine, complete the following procedures:

- (1). Position machine on a firm, level surface.
- (2). Chock wheels securely.
- (3). If machine is equipped with handle type parking brake (CM2033, CM2046, CM2546, and CM2558 built prior to March

1992), engage parking brake by removing parking brake handle from hook on machine frame.

- (4). If machine is equipped with hydraulically operated parking brake (CM1432, CM1432 Plus, CM1732; and CM2033, CM2046, CM2546, and CM2558 built after March 1992), engage parking brake as follows:
  - (a). Using a suitably sized wrench, move brake cam to vertical position.
  - (b). Repeat step (a) for remaining brake cylinder.
- (5). Turn free-wheeling valve knob on main control valve clockwise all the way in.
- (6). Remove chocks from wheels.

**6-3. EMERGENCY CONTROLS AND THEIR LOCATIONS.****a. Platform Emergency Stop Switch.**

This large red button is located on the platform control box and, when depressed, it will immediately stop the machine.

**WARNING**

**CHECK MACHINE DAILY TO MAKE SURE EMERGENCY STOP BUTTON IS IN PLACE AND THAT GROUND CONTROL INSTRUCTIONS ARE IN PLACE AND LEGIBLE.**

**b. Ground Control Station.**

The Ground Control Station is located on the right side of the machine frame. The controls on this panel provide the means for overriding the platform controls and for controlling the platform lift up and down functions from the ground. Place the Platform/Ground Select or Power Selector switch in the GROUND position and operate the lift switch to lift up or down. In addition the Battery or Emergency Stop switch can be used to turn off the machine in the event of an emergency.

**c. Manual Descent.**

The manual descent/lift down solenoid is used, in the event of total power failure, to lower the platform using gravity. On models CM1432, CM1432 Plus and CM1732, the manual descent handle is located on the left front frame rail of the machine. On models CM2033, CM2046, CM2546, and CM2558 built prior to December 1991, the manual descent handle is located on the machine frame, between the sizzor arms.

On models CM2033, CM2046, CM2546, and CM2558 built after December 1991, the manual descent handle is located on the left front of the machine frame. The handle is connected, by cable, to the manual descent/lift down solenoid on the lift cylinder. Pulling the manual descent handle opens the solenoid, lowering the platform.

#### 6-4. EMERGENCY OPERATION.

##### a. Use of Ground Controls.

#### KNOW HOW TO USE THE GROUND CONTROLS IN AN EMERGENCY SITUATION.

Ground personnel must be thoroughly familiar with the machine operating characteristics and the ground control functions. Training should include operation of the machine, review and understanding of this section and hands-on operation of the controls in simulated emergencies.

##### b. Operator Unable to Control Machine.

#### IF THE PLATFORM OPERATOR IS PINNED, TRAPPED OR UNABLE TO OPERATE OR CONTROL THE MACHINE.

- (1). Operate the machine from ground controls **ONLY** with the assistance of other personnel and equipment (cranes, overhead hoists, etc.) as may be required to safely remove the danger or emergency condition.
- (2). Other qualified personnel on the platform may use the platform controls with regular or auxiliary power. **DO NOT CONTINUE OPERATION IF CONTROLS DO NOT FUNCTION NORMALLY.**
- (3). Cranes, forklift trucks or other equipment which may be available are to be used to remove platform occupants and stabilize motion of the machine in case machine controls are inadequate or malfunction when used.

##### c. Platform Caught Overhead.

If the platform becomes jammed or snagged in overhead structures or equipment, do not continue operation of the machine from either the platform or the ground until the operator and all personnel are safely moved to a secure location. Only then should an attempt be made to free the platform using any necessary equipment and personnel. Do not operate controls to cause one or more wheels to leave the ground.

##### d. Righting of Tipped Machine.

A forklift of suitable capacity or equivalent equipment should be placed under the elevated side of the chassis, with a crane or other suitable lifting equipment used to lift the platform while the chassis is lowered by the forklift or other equipment.

##### e. Post-Incident Inspection.

Following any incident, thoroughly inspect the machine and test all functions first from the ground controls, then from the platform controls. Do not lift above 10 feet (3 meters) until you are secure that all damage has been repaired, if required, and that all controls are operating correctly.

#### 6-5. INCIDENT NOTIFICATION.

- a. It is imperative that JLG Industries, Inc. be notified immediately of any incident involving a JLG product. Even if no injury or property damage is evident, the Product Safety and Reliability Department at the factory should be contacted by telephone and provided with all necessary details.
- b. It should be noted that failure to notify the Manufacturer of an incident involving a JLG Industries product within 48 hours of such an occurrence may void any warranty consideration on that particular machine.

**7-1. CAPACITIES.**

- **Hydraulic Oil Tank.**
  - CM1432/CM1432 Plus/CM1732 - 9.5 liters.
  - CM2033/CM2046 - 29.2 liters.
  - CM2546/CM2558 - 29.2 liters.
- **Hydraulic System. (Including Tank)**
  - CM1432/CM1432 Plus/CM1732 - 11.4 liters.
  - CM2033/CM2046 - 34.8 liters.
  - CM2546/CM2558 - 34.8 liters.

**7-2. COMPONENT DATA.**

- **Hydraulic Pump/Electric Motor Assembly.**  
(All Models)
  - 24 Volt DC motor.
  - 2 section gear pump - 11.84 lpm output each section.
- **Battery Charger.**
  - Single Voltage.
    - 220 Volts - 50 Hertz input.
    - 24 Volts DC - 25 Amp output w/auto timer.
  - Dual Voltage.
    - 230 Volts/115 Volts AC - 50 Hertz input.
    - 24 Volts DC - 25 Amp output w/auto timer.
- **Batteries (4).**
  - CM1432/CM1432 Plus/CM1732 - 6 Volt, 137 minutes reserve power @ 75 Amps.
  - Standard - CM2033/CM2046/CM2546/CM2558 - 6 Volt, 245 Amp hour (20 hour rate).
  - High Output - CM2046/CM2546/CM2558 Only - 6 Volt, 370 Amp hour (20 hour rate).
- **Steer/Drive System.**
  - Tires.
    - Standard - CM1432/CM1432 Plus/CM1732 - 4.00 x 8 - 2.5 Solid - Rib.
    - Standard - CM2033/CM2046/CM2546/CM2558 - 5 x 8 - 3.75 Solid - Rib.
    - Optional - CM2046/CM2546/CM2558 - 18 x 9.50 - 8 NHS, 6 ply, poly-filled.
    - Optional - All Models - 5 x 8 - 3.75 Solid, Non-Marking.
  - Parking Brake - All models.
    - Machines built before March 1992 - spring applied, mechanically released.
    - Machines built after March 1992 - dual cylinder, hydraulically applied and released.
  - Drive Motor.
    - CM1432/CM1432 Plus/CM1732/CM2033/CM2046 - 195 cm<sup>3</sup> displacement.
    - CM2546/CM2558 - 244 cm<sup>3</sup> displacement.

- **Rear Wheels and Tires.**
  - Tires.
    - Standard - CM1432/CM1432 Plus/CM1732 - 4.00 x 8 - 2.5 Solid - Rib.
    - Standard - CM2033/CM2046/CM2546/CM2558 - 5 x 8 - 3.75 Solid - Rib.
    - Optional - CM2046/CM2546/CM2558 - 18 x 9.50 - 8 NHS, 6 ply, poly-filled.
    - Optional - All Models - 5 x 8 - 3.75 Solid, Non-Marking.
- **Hydraulic Filter - Inline.**
  - Return - Bypass Type.
  - 25 Microns Nominal.

**7-3. PERFORMANCE DATA.**

- **Travel Speed.**
  - CM1432/CM1432 Plus/CM1732 - 4.0 kph.
  - CM2033/CM2046 - 4.4 kph.
  - CM2546/CM2558 - 3.6 kph.
- **Gradeability.**
  - All Models - 25%.
- **Turning Radius (Outside).**
  - CM1432/CM1432 Plus/CM1732 - 1.5 mtr.
  - CM2033 - 2.2 meters.
  - CM2046/CM2546 - 2.6 meters.
  - CM2558 - 2.7 meters.
- **Lift.**
  - CM1432/CM1432 Plus.
    - Up - 12-16 seconds.
    - Down - 25-30 seconds.
  - CM1732.
    - Up - 15-18 seconds.
    - Down - 25-30 seconds.
  - CM2033/CM2046.
    - Up - 25-30 seconds.
    - Down - 25-30 seconds.
  - CM2546/CM2558.
    - Up - 30-35 seconds.
    - Down - 30-35 seconds.
- **Platform Capacity.**
  - CM1432/CM1732 - 225 kg.
  - CM1432 Plus - 272 kg.
  - CM2033/CM2546 - 340 kg.
  - CM2046/CM2558 - 454 kg.
- **Platform Extension Capacity.**
  - All Models - 113 kg.
- **Machine Weight.**
  - CM1432/CM1432 Plus - approx. 907 kg.
  - CM1732 - approx. 991 kg.
  - CM2033 - approx. 1,456 kg.
  - CM2046 - approx. 1,715 kg.
  - CM2546 - approx. 1,978 kg.
  - CM2558 - approx. 2,100 kg.

- CM1432/CM1432 Plus/CM1732 - 1.0 mtr.
- CM2033/CM2046 - 1.0 meters.
- CM2546/CM2558 - 1.2 meters.
- **Machine Length.**
  - CM1432/CM1432 Plus/CM1732 - 1.7 mtr.
  - CM2033/CM2046 - 2.6 meters.
  - CM2546/CM2558 - 2.6 meters.
- **Machine Width.**
  - CM1432 w/Standard Tires - 0.8 meters.
  - CM1432 Plus w/Standard Tires - 0.8 mtr.
  - CM1732 w/Standard Tires - 0.8 meters.
  - CM2033 w/Standard Tires - 0.8 meters.
  - CM2046 w/Standard Tires - 1.2 meters.
  - CM2046 w/Optional Tires - 1.3 meters.
  - CM2546 w/Standard Tires - 1.2 meters.
  - CM2558 w/Standard Tires - 1.5 meters.
  - CM2558 w/Optional Tires - 1.6 meters.

**Notes**

When temperatures remain consistently below -7 degrees C, an amount of no. 2 diesel fuel, not to exceed 20% of system capacity, may be added to the hydraulic oil reservoir. This diesel fuel will "thin" the hydraulic oil for easier cold weather operation, and will almost completely dissipate from the hydraulic system over a several month period of time. When cold weather is past, it may be necessary to drain and refill the hydraulic system to rid the system of any remaining diesel fuel.

Aside from JLG recommendations, it is not advisable to mix oils of different brands or types, as they may not contain the same required additives or be of comparable viscosities. If use of hydraulic oil other than Kendall Hyken 052, Mobilfluid 424, or BP Energol Type SHS46 is desired, contact JLG Industries for proper recommendations.

**7-4. TORQUE REQUIREMENTS.**

Description	Torque Value (Dry)	Interval Hours
A. Wheel Lugs (All Models)	12.4 kgm (122.0 Nm)	50
B. Wheel Hub Attach Nut to Drive Motor Shaft (CM1432/CM1432 Plus/CM1732)	17-21 kgm (169.5-203.4 Nm)	200/500*
C. Drive Hub to Drive Motor (CM2033/CM2046/CM2546/CM2558)	17-21 kgm (169.5-203.4 Nm)	200/500*

**Note**

When maintenance becomes necessary or a fastener has loosened, refer to the Torque Chart Figure 7-1 to determine proper torque value.

**7-5. LUBRICATION.**

- **Hydraulic Oil.**

**Table 7-1. Hydraulic Oil.**

HYDRAULIC SYSTEM OPERATING TEMPERATURE RANGE	SAE VISCOSITY GRADE
-18° C to -5° C	10W
-18° C to +99° C	10W-20,10W-30
+10° C to +210° C	20W-20

**Note**

Hydraulic oils must have anti-wear qualities at least to API Service Classification GL-3, and sufficient chemical stability for mobile hydraulic system service. JLG Industries recommends Kendall Hyken 052 hydraulic oil, which has an SAE viscosity of 10W-20 and a viscosity index of 152, Mobilfluid 424, which has an SAE viscosity of 10W-30 and a viscosity index of 152, or BP Energol Type SHS46.

- **Lubrication Specifications.**

**Table 7-2. Lubrication Specifications.**

KEY	SPECIFICATIONS
MPG	Multipurpose Grease having a minimum dripping point of 178 degrees C. Excellent water resistance and adhesive qualities, and being of extreme pressure type. (Timken OK 40 pounds minimum.)
EPGL	Extreme Pressure Gear Lube (oil) meeting API service classification GL-5 or MIL-Spec MIL-L-2105.
HO	Hydraulic Oil. API service classification GL-3, e.g. Kendall Hyken 052, Mobilfluid 424, or BP Energol Type SHS46.

**Note**

Refer to Figures 7-2 and 7-3 for specific lubrication procedures.

**7-6. PRESSURE SETTINGS.**

**Notes**

All pressures are given in bar.

On machines built before June 1993, Lift is controlled by P2. On machines built after June 1993, a separate Lift relief is provided.

- **Standard Machine. (All Models.)**

- Main Relief - P1 - 186.
- Main Relief - P2 - 186.
- Steer Relief - 103.
- Hi-Drive Sequence - 76.
- Lift Relief. (If Equipped.)
  - CM1432 - 152.
  - CM1432 Plus - Consult Factory.
  - CM1732 - 159.
  - CM2033 - 124.
  - CM2046 - 148.
  - CM2546 - 141.
  - CM2558 - 159.

SIZE	THD	BOLT DIA. (CM)	TENSILE STRESS AREA (SQ.CM)	SAE GRADE 5 BOLTS						SAE GRADE 8 BOLTS						RECOMMENDED TORQUE WRENCH SIZE			
				CLAMP LOAD (KG)		TORQUE DRY	TORQUE LUB.	TORQUE LOCTITE	CLAMP LOAD (KG)		TORQUE DRY	TORQUE LUB.	TORQUE LOCTITE	CLAMP LOAD (KG)			TORQUE DRY	TORQUE LUB.	TORQUE LOCTITE
				NM	NM	NM	NM	NM	NM	NM	NM	NM	NM	NM	NM		NM	NM	NM
4	40	0.2845	0.0153	172	1	1	1	1	1	1	245	2	1	1	1	2	2	2	
	48	0.2845	0.0168	191	1	1	1	1	1	1	272	2	1	1	1	2	2	2	
6	32	0.3505	0.0232	263	2	2	2	2	2	2	372	3	2	2	2	3	3	3	
	40	0.3505	0.0258	277	2	2	2	2	2	2	417	3	2	2	2	3	3	3	
8	32	0.4166	0.0356	408	4	4	4	4	4	4	572	5	4	4	4	5	5	5	
	36	0.4166	0.0374	426	4	4	4	4	4	4	599	5	4	4	4	5	5	5	
10	24	0.4826	0.0445	508	5	5	5	5	5	5	717	7	5	5	5	7	7	7	
	32	0.4826	0.0508	583	6	6	6	6	6	6	817	8	6	6	6	8	8	8	
1/4	20	0.6350	0.0808	916	11	11	11	11	11	11	1297	16	12	12	12	18	18	18	
	28	0.6350	0.0925	1052	14	14	14	14	14	14	1488	19	14	14	14	21	21	21	
5/16	18	0.7938	0.1331	1515	23	23	23	23	23	23	2141	34	25	25	25	41	41	41	
	24	0.7938	0.1473	1678	26	26	26	26	26	26	2821	34	27	27	27	41	41	41	
3/8	16	0.9525	0.1969	2241	41	41	41	41	41	41	3175	61	48	48	48	68	68	68	
	24	0.9525	0.2230	2540	48	48	48	48	48	48	3583	68	48	48	48	75	75	75	
7/16	14	1.1112	0.2700	3085	68	68	68	68	68	68	4332	95	75	75	75	109	109	109	
	20	1.1112	0.3015	3425	75	75	75	75	75	75	4854	109	81	81	81	122	122	122	
1/2	13	1.2700	0.3604	4105	102	102	102	102	102	102	5783	149	109	109	109	163	163	163	
	20	1.2700	0.4061	4854	122	122	122	122	122	122	6532	163	122	122	122	183	183	183	
9/16	12	1.4288	0.4623	5262	149	149	149	149	149	149	7439	204	149	149	149	224	224	224	
	18	1.4288	0.5156	5874	163	163	163	163	163	163	8278	231	176	176	176	258	258	258	
5/8	11	1.5875	0.5740	6532	204	204	204	204	204	204	9231	298	231	231	231	326	326	326	
	18	1.5875	0.6502	7394	231	231	231	231	231	231	10433	326	244	244	244	359	359	359	
3/4	10	1.9050	0.8484	9662	353	353	353	353	353	353	13653	515	380	380	380	570	570	570	
	16	1.9050	0.3730	10796	407	407	407	407	407	407	15241	570	434	434	434	631	631	631	
7/8	9	2.2225	1.1735	13336	583	583	583	583	583	583	18870	814	624	624	624	895	895	895	
	14	2.2225	1.2929	14697	637	637	637	637	637	637	20775	895	678	678	678	983	983	983	
1	8	2.5400	1.5392	17509	868	868	868	868	868	868	23360	1220	922	922	922	1342	1342	1342	
	12	2.5400	1.6840	19142	949	949	949	949	949	949	27080	1356	1003	1003	1003	1492	1492	1492	
1 1/8	7	2.8575	1.9380	19187	1085	1085	1085	1085	1085	1085	31162	1736	1302	1302	1302	1898	1898	1898	
	12	2.8575	2.1742	21546	1193	1193	1193	1193	1193	1193	34927	1953	1464	1464	1464	2136	2136	2136	
1 1/4	7	3.1750	2.4613	24404	1519	1519	1519	1519	1519	1519	39554	2468	1844	1844	1844	2712	2712	2712	
	12	3.1750	2.7254	27035	1681	1681	1681	1681	1681	1681	43818	2712	2034	2034	2034	2983	2983	2983	
1 3/8	6	3.4925	2.9337	29076	1980	1980	1980	1980	1980	1980	47174	3227	2413	2413	2413	3559	3559	3559	
	12	3.4925	3.3401	33113	2278	2278	2278	2278	2278	2278	53570	3688	2766	2766	2766	4068	4068	4068	
1 1/2	6	3.8100	3.5687	35381	2630	2630	2630	2630	2630	2630	57380	4284	3200	3200	3200	4712	4712	4712	
	12	3.8100	4.0132	39781	2983	2983	2983	2983	2983	2983	142200	4827	3607	3607	3607	5322	5322	5322	

Figure 7-1. Torque Chart.

NOTE: Tensile strength for bolt size 4 to 1 - 8,274 (min. bar), size 1-1/8 to 1-1/2 - 7,240 (min. bar).

\*Torque multiplier.

Torque specifications are given in Newton-meters.



SAE Grade 5



SAE Grade 8

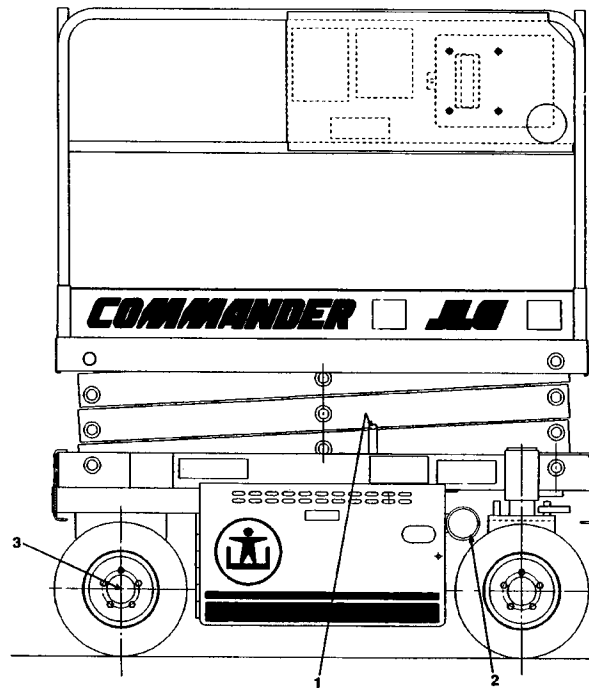

INDEX NUMBER	COMPONENT	NO/TYPE LUBE POINTS	LUBE/METHOD	INTERVAL HOURS	COMMENTS
1	Hydraulic Oil	Dipstick/Fill Tube/ Drain Plug	HO - Check HO Level (See Note 4) HO - Change HO	10/2000	Check oil every 10 hrs. Change oil every 2000 hrs.
2	Hydraulic Filter Element	N/A	N/A	40/250	Change filter after first 40 hours of operation, then every 250 hours thereafter.
3	Wheel Bearings	2 - Rear Wheels	MPG - Repack	2000	N/A

**Key To Lubricants:**

- MPG - Multi-Purpose Grease
- HO - Hydraulic Oil - Kendall Hyken 052

**WARNING**

**TO AVOID PERSONAL INJURY, USE SAFETY PROP FOR ALL MAINTENANCE REQUIRING PLATFORM TO BE ELEVATED.**

**Notes:**

1. Be sure to lubricate like items on each side of machine.
2. Recommended lubricating intervals are based on normal use. If machine is subjected to severe operating conditions, user must adjust lubricating requirements accordingly.
3. Lubricating intervals are calculated on 50 hours of machine operation per week.
4. Prior to checking hydraulic oil level, operate machine through one complete cycle of lift function (full up and down). Failure to do so will result in incorrect oil level reading on hydraulic tank.
5. When lift cylinder is removed from machine, coat inside of rod end barrel end bushings with Gredag 714 grease prior to installation of lift cylinder attach pins. When installing attach pins, be sure not to dislodge or damage o-rings inside bushings.

Figure 7-2. Lubrication Chart - CM1432/CM1432 Plus/CM1732.

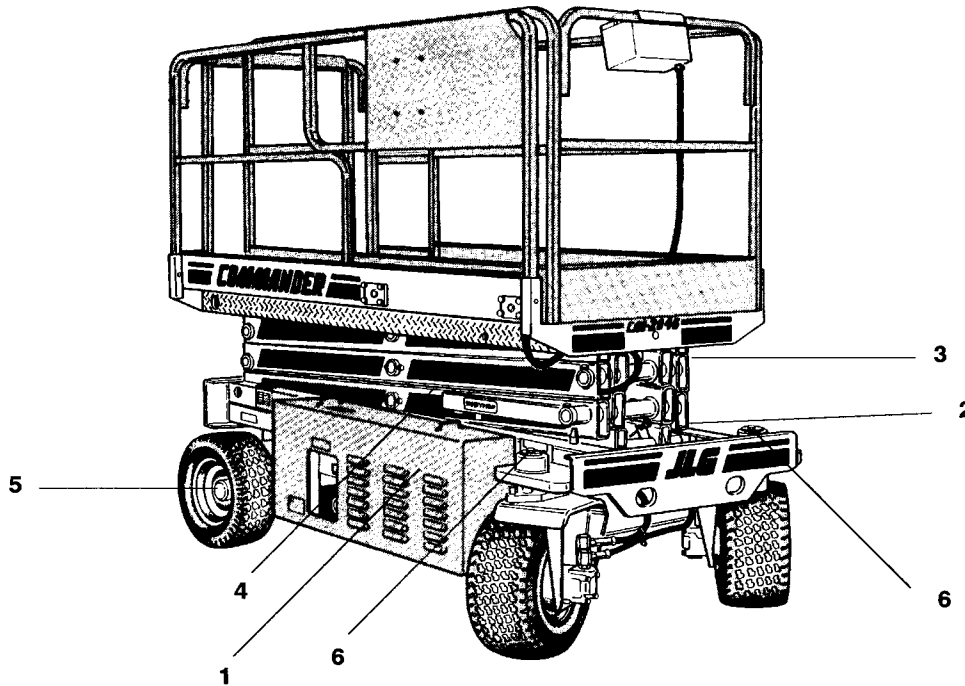

INDEX NUMBER	COMPONENT	NO/TYPE LUBE POINTS	LUBE/METHOD	INTERVAL HOURS	COMMENTS
1	Hydraulic Oil	Fill Cap/Drain Plug	HO - Check HO Level (See Note 4) HO - Change HO	10/2000	Check oil every 10 hrs. Change oil every 2000 hrs.
2	Hydraulic Filter Element	N/A	N/A	40/250	Change filter after first 40 hours of operation, then every 250 hours thereafter.
3	Lift Cylinder - Rod End	1 Grease Fitting	MPG - Pressure Gun	50	N/A
4	Lift Cylinder - Barrel End	1 Grease Fitting	MPG - Pressure Gun	50	N/A
5	Wheel Bearings	2 - Rear Wheels	MPG - Repack	2000	N/A
6	Kingpin Housing (If Equipped - See Note 5)	2 Grease Fittings	MPG - Pressure Gun	50	N/A

**Key To Lubricants:**

**MPG - Multi-Purpose Grease**

**HO - Hydraulic Oil - Kendall Hyken 052**

**WARNING**

**TO AVOID PERSONAL INJURY, USE SAFETY PROP FOR ALL MAINTENANCE REQUIRING PLATFORM TO BE ELEVATED.**

**Notes:**

1. Be sure to lubricate like items on each side of machine.
2. Recommended lubricating intervals are based on normal use. If machine is subjected to severe operating conditions, user must adjust lubricating requirements accordingly.
3. Lubricating intervals are calculated on 50 hours of machine operation per week.
4. Prior to checking hydraulic oil level, operate machine through one complete cycle of lift function (full up and down). Failure to do so will result in incorrect oil level reading on hydraulic tank.
5. Machines built before March 1992 will be equipped with grease fittings at item 6; machines built after March 1992 will not be equipped with grease fittings.

Figure 7-3. Lubrication Chart - CM2033/CM2046/CM2546/CM2558.

- **Machine with Proportional Drive.**  
(CM2033/CM2046/CM2546/CM2558 Only.)
  - Main Relief - P1 - 186.
  - Main Relief - P2 - 186.
  - Steer Relief - 103.
  - Hi-Drive Sequence - 76.
  - Lift Relief. (If Equipped.)
    - CM1432 - 152.
    - CM1432 Plus - TBD.
    - CM1732 - 159.
    - CM2033 - 124.
    - CM2046 - 148.
    - CM2546 - 141.
    - CM2558 - 159.

**7-8. SERIAL NUMBER LOCATIONS.**  
(See Figure 7-3.)

For machine identification, a serial number plate is affixed to the machine. On models CM1432, CM1432 Plus, and CM1732, the plate is located on the right front side of the machine frame, just behind the right front steer spindle. In addition, if the serial number plate is damaged or missing, the machine serial number is stamped on the right front top of the frame, in front of the right front steer spindle. On models CM2033, CM2046, CM2546 and CM2558, the plate is located on the rear bumper of the machine frame. In addition, if the serial number plate is damaged or missing, the machine serial number is stamped on the right front of the frame, near the steering spindle and bushing.

**7-7. CYLINDER SPECIFICATIONS.**

**Note**

All dimensions are given in centimeters.

DESCRIPTION	BORE	STROKE	ROD DIA.
Lift Cylinder (CM1432)	6.3	70.0	3.8
Lift Cylinder (CM1432 Plus/CM1732)	5.1	70.0	5.1
Lift Cylinder (CM2033/CM2046)	5.1	125.4	5.1
Lift Cylinder (CM2546/CM2558)	8.9	120.0	6.4
Steer Cylinder - Double Rod - All Models	5.1	7.0 each rod	3.8
Cushion Cylinder (Accumulator) - CM1432/CM1432 Plus/CM1732	3.8	15.6	n/a
Cushion Cylinder (Accumulator) - CM2033/CM2046/CM2546/2558 - Machines Built Before March 1992	3.8	15.6	n/a
Cushion Cylinder (Accumulator) - CM2033/CM2046/CM2546/2558 - Machines Built After March 1992	5.1	15.6	n/a
Parking Brake Cylinder - CM2033/CM2046/CM2546/CM2558 - Machines Built Before March 1992	7.6	3.8	3.8
Parking Brake Cylinder - All CM1432/CM1432 Plus/CM1732/CM2033/CM2046/CM2546/CM2558 - Machines Built After March 1992	4.4	2.2	2.9

**7-9. LIMIT SWITCHES.**

The machines are equipped with the following limit switches:

- Tilt Switch (3 degrees) - Illuminates light on platform and sounds alarm when machine is 3 degrees out of level in any direction with platform raised. With platform lowered and machine 3 degrees out of level in any direction, light is illuminated only.
- Tilt Switch (3 degrees) (French Specification) - Drive forward and reverse and lift up functions are cut out when machine is 3 degrees out of level in any direction with the platform raised.
- Platform Overload Cut-Out (French Specification) - All machine functions are cut out when platform is loaded to 120% of rated capacity (see paragraph 7-3). Machine functions are restored when overload condition is corrected.
- High Drive Cut-Out - High drive speed is cut out when platform is raised above stowed position.
- Drive Cut-Out - Drive function is cut out when platform is raised above 2.7 meters on Models CM1432 and CM1432 Plus, above 3.25 meters on Model CM1732, above 5 meters on Models CM2033 and CM2046, or above 6.4 meters on Models CM2546 and CM2558.
- Drive Cut-Out (Italian Specification) - Drive function is cut out when platform is raised above stowed position.



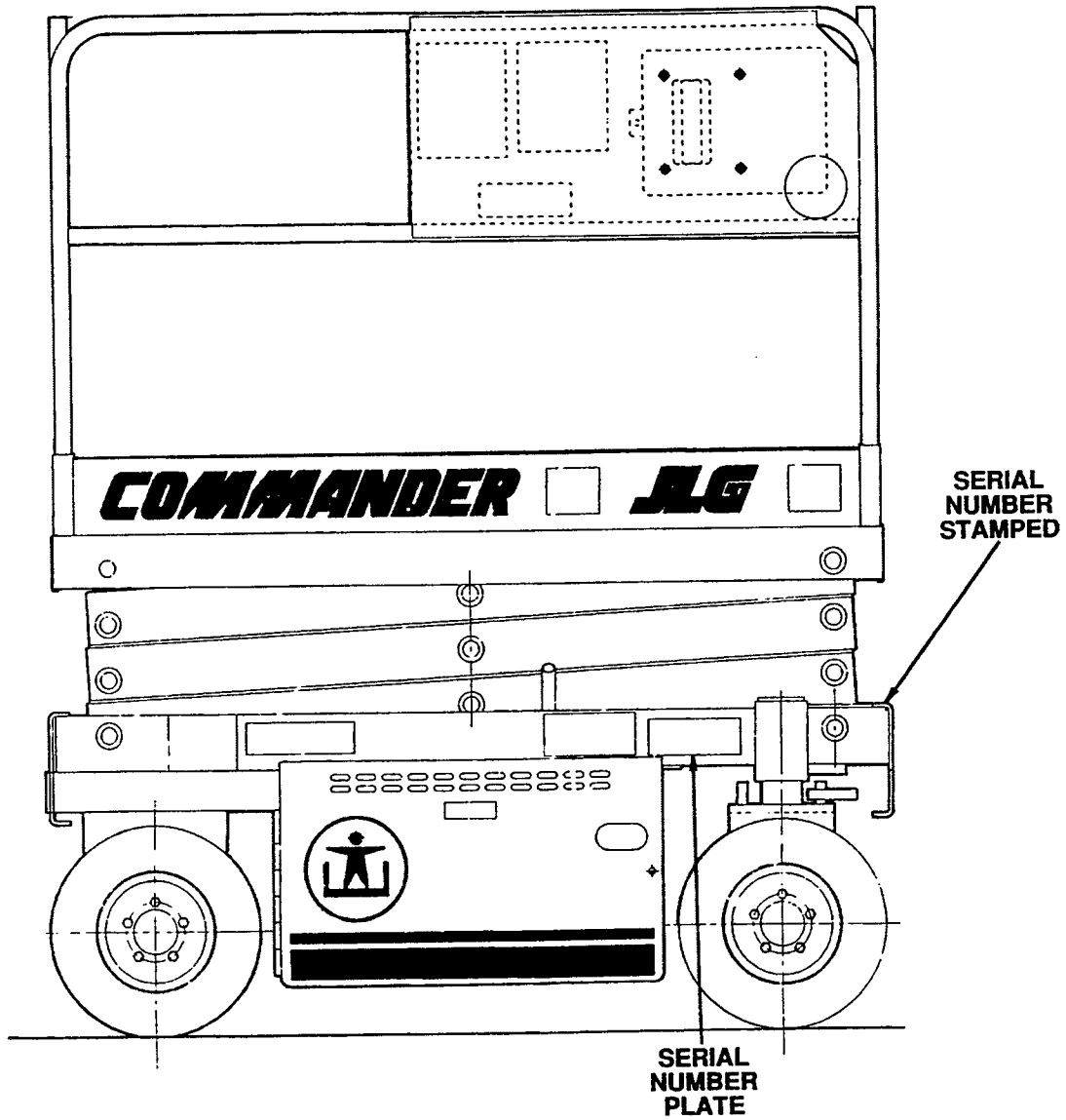

Figure 7-4. Serial Number Locations - CM1432/CM1432 Plus/CM1732.

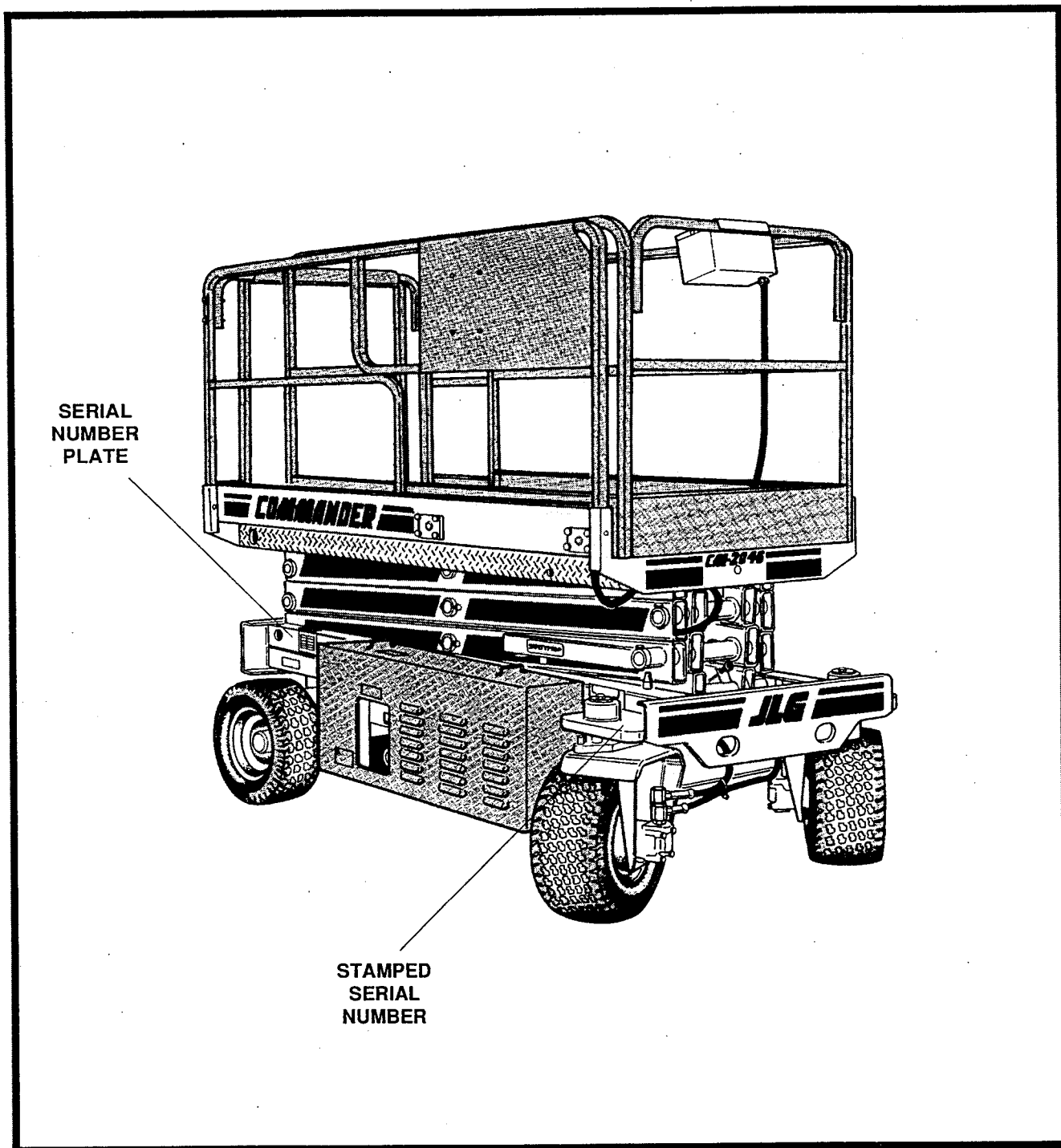

Figure 7-5. Serial Number Locations - CM2033/CM2046/CM2546/CM2558..

**7-10. MAJOR COMPONENT WEIGHTS.**

COMPONENT	KG
Platform (76 cm. x 163 cm.) - CM1432/CM1432 Plus/CM1732.	89
Platform (76 cm. x 239 cm.) - CM2033.	157
Platform (107 cm. x 239 cm.) - CM2046/CM2546.	225
Platform (137 cm. x 239 cm.) - CM2558.	295
Platform Extension - All Models.	50
Arm Assembly - CM1432/CM1432 Plus. (Includes Lift Cylinder)	245
Arm Assembly - CM1732. (Includes Lift Cylinder)	329
Arm Assembly - CM2033/CM2046. (Includes Lift Cylinder)	590
Arm Assembly - CM2546/CM2558. (Includes Lift Cylinder)	817
Chassis - CM1432/CM1432 Plus/CM1732 w/Solid Tires.	523
Chassis - CM2033 w/Solid Tires.	671
Chassis - CM2046 w/Solid Tires.	817
Chassis - CM2046 w/Foam-Filled Tires.	848
Chassis - CM2546 w/Solid Tires.	817
Chassis - CM2558 w/Solid Tires.	880
Chassis - CM2558 w/Foam-Filled Tires.	934

**7-11. CRITICAL STABILITY WEIGHTS.**

**WARNING**

**DO NOT REPLACE ITEMS CRITICAL TO STABILITY, SUCH AS BATTERIES OR SOLID TIRES, WITH ITEMS OF DIFFERENT WEIGHT OR SPECIFICATION. DO NOT MODIFY UNIT IN ANY WAY TO AFFECT STABILITY.**

**Table 7-3. Critical Stability Weights - CM1432, CM1432 Plus, CM1732.**

Item	CM1432	CM1432 Plus	CM1732
Tires - Solid (each)	10 kg	10 kg	10 kg
Motor/Pump Assembly	20 kg	20 kg	20 kg
Batteries - each	35 kg	35 kg	35 kg
Batteries - Combined	218 kg	218 kg	218 kg

**Table 7-4. Critical Stability Weights - CM2033, CM2046, CM2546, CM2558.**

Item	CM2033	CM2046	CM2546	CM2558
Tires - Solid (each)	12 kg	12 kg	12 kg	12 kg
Motor/Pump Assembly	20 kg	20 kg	20 kg	20 kg
Batteries - Std - Each	35 kg	35 kg	35 kg	35 kg
Batteries - Standard - Combined	140 kg	140 kg	140 kg	140 kg
Batteries - High Output - Each	N/A	54 kg	54 kg	54 kg
Batteries - High Output - Combined	N/A	218 kg	218 kg	218 kg



**8-1. GENERAL.**

- a. This section provides information necessary to perform maintenance on the sizzor lift. Descriptions, techniques and specific procedures are designed to provide the safest and most efficient maintenance for use by personnel responsible for ensuring the correct installation and operation of machine components and systems.

**Note**

**Maintenance procedures provided in this section apply to all seven sizzor lift models covered in this manual. Procedures that apply to a specific model will be so noted.**

**CAUTION**

**WHEN AN ABNORMAL CONDITION IS NOTED AND PROCEDURES CONTAINED HEREIN DO NOT SPECIFICALLY RELATE TO THE NOTED IRREGULARITY, WORK SHOULD BE STOPPED AND TECHNICALLY QUALIFIED GUIDANCE OBTAINED BEFORE WORK IS RESUMED.**

- b. The maintenance procedures included consist of servicing and component removal and installation, disassembly and assembly, inspection, lubrication and cleaning. Information on any special tools or test equipment is also provided where applicable.

**8-2. SERVICING AND MAINTENANCE GUIDELINES.****a. General.**

The following information is provided to assist you in the use and application of servicing and maintenance procedures contained in this chapter.

**b. Safety and Workmanship.**

Your safety, and that of others, is the first consideration when engaging in the maintenance of equipment. Always be conscious of weight. Never attempt to move heavy parts without the aid of a mechanical device. Do not allow heavy objects to rest in an unstable position. When raising a portion of the equipment, ensure that adequate support is provided.

**c. Cleanliness.**

- (1). The most important single item in preserving the long service life of a machine is to keep dirt and foreign materials out of the vital components. Precautions have been taken to safeguard against this. Shields, covers, seals, and filters are provided to

keep air, fuel, and oil supplies clean; however, these items must be maintained on a scheduled basis in order to function properly.

- (2). At any time when air, fuel, or oil lines are disconnected, clear adjacent areas as well as the openings and fittings themselves. As soon as a line or component is disconnected, cap or cover all openings to prevent entry of foreign matter.
- (3). Clean and inspect all parts during servicing or maintenance, and assure that all passages and openings are unobstructed. Cover all parts to keep them clean. Be sure all parts are clean before they are installed. New parts should remain in their containers until they are ready to be used.

**d. Components Removal and Installation.**

- (1). Use adjustable lifting devices, whenever possible, if mechanical assistance is required. All slings (chains, cables, etc.) should be parallel to each other and as near perpendicular as possible to top of part being lifted.
- (2). Should it be necessary to remove a component on an angle, keep in mind that the capacity of an eyebolt or similar bracket lessens, as the angle between the supporting structure and the component becomes less than 90 degrees.
- (3). If a part resists removal, check to see whether all nuts, bolts, cables, brackets, wiring, etc., have been removed and that no adjacent parts are interfering.

**e. Component Disassembly and Reassembly.**

When disassembling or reassembling a component, complete the procedural steps in sequence. Do not partially disassemble or assemble one part, then start on another. Always recheck your work to assure that nothing has been overlooked. Do not make any adjustments, other than those recommended, without obtaining proper approval.

**f. Pressure-Fit Parts.**

When assembling pressure-fit parts, use an "anti-seize" or molybdenum disulfide base compound to lubricate the mating surface.

**g. Bearings.**

- (1). When a bearing is removed, cover it to keep out dirt and abrasives. Clean bear-

ings in nonflammable cleaning solvent and allow to drip dry. Compressed air can be used but do not spin the bearing.

- (2). Discard bearings if the races and balls (or rollers) are pitted, scored, or burned.
- (3). If bearing is found to be serviceable, apply a light coat of oil and wrap it in clean (waxed) paper. Do not unwrap reusable or new bearings until they are ready to install.
- (4). Lubricate new or used serviceable bearings before installation. When pressing a bearing into a retainer or bore, apply pressure to the outer race. If the bearing is to be installed on a shaft, apply pressure to the inner race.

#### **h. Gaskets.**

Check that holes in gaskets align with openings in the mating parts. If it becomes necessary to hand-fabricate a gasket, use gasket material or stock of equivalent material and thickness. Be sure to cut holes in the right location, as blank gaskets can cause serious system damage.

#### **i. Bolt Usage and Torque Application.**

- (1). Use bolts of proper length. A bolt which is too long will bottom before the head is tight against its related part. If a bolt is too short, there will not be enough thread area to engage and hold the part properly. When replacing bolts, use only those having the same specifications of the original, or one which is equivalent.
- (2). Unless specific torque requirements are given within the text, standard torque values should be used on heat-treated bolts, studs, and steel nuts, in accordance with recommended shop practices. (See Figure 7-1.)

#### **j. Hydraulic Lines and Electrical Wiring.**

Clearly mark or tag hydraulic lines and electrical wiring, as well as their receptacles, when disconnecting or removing them from the unit. This will assure that they are correctly reinstalled.

#### **k. Hydraulic System.**

- (1). Keep the system clean. If evidence of metal or rubber particles is found in the hydraulic system, drain and flush the entire system.
- (2). Disassemble and reassemble parts on clean work surface. Clean all metal parts

with non-flammable cleaning solvent. Lubricate components, as required, to aid assembly.

#### **l. Lubrication.**

Service applicable components with the amount, type, and grade of lubricant recommended in this manual, at the specified intervals. When recommended lubricants are not available, consult your local supplier for an equivalent that meets or exceeds the specifications listed.

#### **m. Batteries.**

Clean batteries, using a non-metallic brush and a solution of baking soda and water. Rinse with clean water. After cleaning, thoroughly dry batteries and coat terminals with an anti-corrosion compound.

#### **n. Lubrication and Servicing.**

Components and assemblies requiring lubrication and servicing are shown in Figures 7-2 and 7-3.

### **8-3. LUBRICATION INFORMATION.**

#### **a. Hydraulic System.**

- (1). The primary enemy of a hydraulic system is contamination. Contaminants enter the system by various means, e.g., using inadequate hydraulic oil, allowing moisture, grease, filings, sealing components, sand, etc., to enter when performing maintenance, or by permitting the pump to cavitate due to insufficient system warm-up or leaks in the pump supply (suction) lines.
- (2). The design and manufacturing tolerances of the component working parts are very close, therefore, even the smallest amount of dirt or foreign matter entering a system can cause wear or damage to the components and generally results in faulty operation. Every precaution must be taken to keep hydraulic oil clean, including reserve oil in storage. Hydraulic system filters should be checked, cleaned, and/or replaced as necessary, at the specified intervals required in Figures 7-2 and 7-3. Always examine filters for evidence of metal particles.
- (3). Cloudy oils indicate a high moisture content which permits organic growth, resulting in oxidation or corrosion. If this condition occurs, the system must be drained, flushed, and refilled with clean oil.

- (4). It is not advisable to mix oils of different brands or types, as they may not contain the same required additives or be of comparable viscosities. Good grade mineral oils, with viscosities suited to the ambient temperatures in which the machine is operating, are recommended for use.

**Note**

**Metal particles may appear in the oil or filters of new machines due to the wear-in of meshing components.**

**b. Hydraulic Oil.**

- (1). Refer to Table 7-1 for recommendations for viscosity ranges.
- (2). JLG recommends Kendall Hyken 052 hydraulic oil, which has an SAE viscosity of 10W-20 and a viscosity index of 152, Mobilfluid 424 hydraulic oil, which has an SAE viscosity of 10W-30 and a viscosity index of 152, or BP Energol Type SHS46.

**Note**

**Start-up of hydraulic system with oil temperatures below -26 degrees C is not recommended. If it is necessary to start the system in a sub-zero environment, it will be necessary to heat the oil with a low density, 100VAC heater to a minimum temperature of -26 degrees C.**

- (3). The only exception to the above is to drain and fill the system with Mobil DTE 11 oil or its equivalent. This will allow start up at temperatures down to -29 degrees C. However, use of this oil will give poor performance at temperatures above 49 degrees C. Systems using DTE 11 oil should not be operated at temperatures above 94 degrees C under any condition.

**c. Changing Hydraulic Oil.**

- (1). Use of any of the recommended crankcase or hydraulic oils eliminates the need for changing the oil on a regular basis. However, filter elements must be changed after the first 40 hours of operation and every 250 hours thereafter. If it is necessary to change the oil, use only those oils meeting or exceeding the specifications appearing in this manual. If unable to obtain the same type of oil supplied with the machine, consult local supplier for assistance in selecting the proper equivalent. Avoid mixing petroleum and synthetic base oils. JLG Industries recommends changing the hydraulic oil annually.

- (2). Use every precaution to keep the hydraulic oil clean. If the oil must be poured from the original container into another, be sure to clean all possible contaminants from the service container. Always clean the mesh element of the filter and replace the cartridge any time the system oil is changed.
- (3). While the unit is shut down, a good preventive maintenance measure is to make a thorough inspection of all hydraulic components, lines, fittings, etc., as well as a functional check of each system, before placing the machine back in service.

**d. Lubrication Specifications.**

Specified lubricants, as recommended by the component manufacturers, are always the best choice, however, multi-purpose greases usually have the qualities which meet a variety of single purpose grease requirements. Should any question arise regarding the use of greases in maintenance stock, consult your local supplier for evaluation. Refer to Table 7-2 for an explanation of the lubricant key designations appearing in the Lubrication Chart.

## 8-4. CYLINDERS - THEORY OF OPERATION.

- a. Cylinders are of the double acting type. The Lift and Steer systems incorporate double acting cylinders. A double acting cylinder is one that requires oil flow to operate the cylinder rod in both directions. Directing oil (by actuating the corresponding control valve to the piston side of the cylinder) forces the piston to travel toward the rod end of the barrel, extending the cylinder rod (piston attached to rod). When the oil flow is stopped, movement of the rod will stop. By directing oil to the rod side of the cylinder, the piston will be forced in the opposite direction and the cylinder rod will retract.
- b. A holding valve is used in the Lift circuit to prevent retraction of the cylinder rod should a hydraulic line rupture or a leak develop between the cylinder and its related control valve.

## 8-5. VALVES - THEORY OF OPERATION.

**a. Solenoid Control Valves (Bang-Bang).**

Control valves used are four-way three-position solenoid valves of the sliding spool design. When a circuit is activated and the control valve solenoid energizes, the spool is shifted and the corresponding work port opens to permit oil flow to the component in the selected circuit, with the opposite work port opening to reservoir. Once the circuit is deactivated (control returned to neutral), the valve spool returns to

neutral (center) and oil flow is then directed through the valve body and returns to reservoir. A typical control valve consists of the valve body, sliding spool, and two solenoid assemblies. The spool is machine fitted in the bore of the valve body. Lands on the spool divide the bore into various chambers, which, when the spool is shifted, align with corresponding ports in the valve body open to common flow. At the same time other ports would be blocked to flow. The spool is spring-loaded to center position, therefore when the control is released, the spool automatically returns to neutral, prohibiting any flow through the circuit.

#### **b. Proportional Control Valves - Vickers.**

The Vickers proportional valves provide a power output matching that required by the load. A small line connected to a load sensing port feeds load pressure back to a sequence valve. The sequence valve senses the difference between the load and pump outlet pressure, and varies the pump displacement to keep the difference constant. This differential pressure is applied across the valve's meter-in spool, with the effect that pump flow is determined by the degree of spool opening, independent of load pressure. Return lines are connected together, simplifying routing of return flow and to help reduce cavitation.

Load sensing lines connect through shuttle valves to feed the highest load signal back to the sequence valve. Integral actuator port relief valves, anti-cavitation check valves, and load check valves are standard.

#### **c. Relief Valves.**

Main relief valves are installed at various points within the hydraulic system to protect associated systems and components against excessive pressure. Excessive pressure can be developed when a cylinder reaches its limit of travel and the flow of pressurized fluid continues from the system control. The relief valve provides an alternate path for the continuing flow from the pump, thus preventing rupture of the cylinder, hydraulic line or fitting. Complete failure of the system pump is also avoided by relieving circuit pressure. The relief valve is installed in the circuit between the pump outlet (pressure line) and the cylinder of the circuit, generally as an integral part of the system valve bank. Relief pressures are set slightly higher than the load requirement, with the valve diverting excess pump delivery back to the reservoir when operating pressure of the component is reached.

#### **d. Crossover Relief Valves.**

Crossover relief valves are used in circuits where the actuator requires an operating pressure lower than that supplied to the system. When the circuit is activated and the required pressure at the actuator is developed, the crossover relief diverts excess pump flow to the reservoir. Individual, integral reliefs are provided for each side of the circuit.

### **8-6. COMPONENT FUNCTIONAL DESCRIPTION.**

#### **a. Hydraulic Pump.**

The main hydraulic pump is an integral part of the electric motor/pump assembly, located at the rear of the battery and ground control tray on the frame of the machine. The pump is a two-section pump that provides an output of 11.8 lpm from each pump section.

#### **b. Accumulator. (Cushion Cylinder)**

The accumulator is located on the rear of the battery and ground control tray on the frame of the machine. The accumulator is a cylinder with an orifice at each end to restrict the flow of hydraulic fluid through the cylinder. The accumulator is mounted inline in the drive circuit and serves to "smooth" acceleration and deceleration of the machine.

#### **c. Lift Cylinder Holding/Manual Descent Valve.**

The lift cylinder holding/manual descent valve is located on top of the lift cylinder. The holding valve is a normally closed solenoid valve which holds the platform in place when raised. When activated, the valve opens to permit lift down. A cable is connected to the solenoid valve which, when pulled, manually opens the lift down port of the valve and allows the platform to be lowered in the event hydraulic power is lost.

#### **d. Positive Traction Valve.**

The positive traction solenoid valve is located on the main control valve and is activated by a toggle switch on the platform control box. When activated, it equally divides the flow of hydraulic oil in the drive circuit to send an equal amount of oil to each drive motor.

### **8-7. WEAR PADS.**

#### **a. Sliding Pads.**

The original thickness of the sliding pads is 90 millimeters. Replace sliding pads when worn to 83 millimeters.



**8-8. CYLINDER CHECKING PROCEDURES.****Note**

Cylinder checks must be performed any time a cylinder component is replaced or when improper system operation is suspected.

- a. Cylinder w/o Counterbalance Valves - Brake Cylinder, Steer Cylinder, Cushion Cylinder (Accumulator).

**IMPORTANT****OPERATE FUNCTIONS FROM GROUND CONTROL STATION ONLY.**

- (1). Using all applicable safety precautions, activate motor and fully extend cylinder to be checked. Shut down motor.
- (2). Carefully disconnect hydraulic hose from retract port of cylinder. There will be initial weeping of hydraulic fluid which can be caught in a suitable container. After the initial discharge, there should be no further leakage from the retract port.
- (3). Activate motor and activate cylinder extend function. Check retract port for leakage.
- (4). If cylinder leakage is 6-8 drops per minute or more, piston seals are defective and must be replaced. If cylinder retract port leakage is less than 6-8 drops per minute, carefully reconnect hose to retract port and retract cylinder.
- (5). With cylinder fully retracted, shut down motor and carefully disconnect hydraulic hose from cylinder extend port.
- (6). Activate motor and activate cylinder retract function. Check extend port for leakage.
- (7). If cylinder leakage is 6-8 drops per minute or more, piston seals are defective and must be replaced. If extend port leakage is less than 6-8 drops per minute, carefully reconnect hose to extend port, then activate cylinder through one complete cycle and check for leaks.

- b. Cylinders w/Single Counterbalance Valves - Lift Cylinder.

**IMPORTANT****OPERATE ALL FUNCTIONS FROM GROUND CONTROL STATION ONLY.**

- (1). Using all applicable safety precautions, activate hydraulic system.

**WARNINGS**

**WHEN WORKING ON THE LIFT CYLINDER, RAISE THE PLATFORM COMPLETELY AND SUPPORT THE PLATFORM USING A SUITABLE OVERHEAD LIFTING DEVICE.**

**DO NOT FULLY EXTEND LIFT CYLINDER TO END OF STROKE. RETRACT CYLINDER SLIGHTLY TO AVOID TRAPPING PRESSURE.**

- (2). Raise platform completely, then retract lift cylinder slightly to avoid trapping pressure. Place a suitable overhead lifting device approximately 2.5 centimeters below the platform.
- (3). Shut down hydraulic system and allow machine to sit for 10-15 minutes. Carefully remove hydraulic hoses from cylinder port block.
- (4). There will be initial weeping of hydraulic fluid, which can be caught in a suitable container. After the initial discharge, there should not be any further leakage from the ports. If leakage continues at a rate of 6-8 drops per minute or more, cylinder repairs must be made. If the retract port is leaking, the piston seals are defective and must be replaced. If the extend port is leaking, the counterbalance valve is defective and must be replaced.
- (5). If no repairs are necessary or when repairs have been made, carefully reconnect hydraulic hoses to the appropriate ports.
- (6). Remove lifting device from platform, activate hydraulic system and run cylinder through one complete cycle to check for leaks.

**8-9. CYLINDER REMOVAL AND INSTALLATION.****a. Lift Cylinder Removal.**

- (1). Place the machine on a flat and level surface. Start the motor and raise the platform. Shut down the engine and attach a suitable lifting device to the platform.
- (2). Remove the two bolts, lockwashers and hex nuts securing the cylinder rod attach pin to the upper inner arm assembly. Using a suitable brass drift, drive out the rod end attach pin from the arm assembly.
- (3). Retract the lift cylinder rod completely.
- (4). Tag and disconnect, then cap the lift cylinder hydraulic lines and ports.

- (5). Remove the two bolts securing one of the the barrel end attach pin retaining plates to the lower arm assembly. Using a suitable brass drift, drive out the barrel end attach pin from the arm assembly.
- (6). Carefully remove the cylinder from the Sizzor lift and place in a suitable work area.

#### d. Lift Cylinder Installation.

- (1). Install lift cylinder in place using suitable slings, aligning barrel end attach pin mounting holes on lower arm assembly.
- (2). Using a suitable drift, drive the barrel end attach pin through the mounting holes in the lift cylinder and the lower arm assembly. Secure in place with the pin retaining plate using the two bolts.
- (3). Remove cylinder port plugs and hydraulic line caps and correctly attach lines to cylinder ports.
- (4). Extend the cylinder rod until the attach pin hole aligns with those in the upper arm assembly. Using a suitable drift, drive the cylinder rod attach pin through the aligned holes, taking care to align the pin retaining holes with the stud on the turntable upright. Secure the pin in place with the two bolts, lockwashers and hex nuts.
- (5). Lower platform to stowed position and shut down motor. Check hydraulic fluid level and adjust accordingly.

### 8-10. CYLINDER REPAIR. (EXCEPT BRAKE CYLINDER.)

#### Note

The following are general procedures that apply to all of the cylinders on this machine, except the brake cylinder. Procedures that apply to a specific cylinder will be so noted.

#### a. Disassembly.

#### IMPORTANT

**DISASSEMBLY OF THE CYLINDER SHOULD BE PERFORMED ON A CLEAN WORK SURFACE IN A DIRT FREE WORK AREA.**

- (1). Connect a suitable auxiliary hydraulic power source to the cylinder port block fitting.

#### WARNING

**DO NOT FULLY EXTEND CYLINDER TO END OF STROKE. RETRACT CYLINDER SLIGHTLY TO AVOID TRAPPING PRESSURE.**

- (2). Operate the hydraulic power source and extend the cylinder. Do not fully extend cylinder. Shut down and disconnect the power source. Adequately support the cylinder rod, if applicable.
- (3). If applicable, remove the cartridge-type holding valve and fittings from the cylinder port block. Discard o-rings.
- (4). Place the cylinder barrel into a suitable holding fixture.
- (5). Using a suitable spanner wrench, loosen the cylinder head retainer, if applicable, and/or cylinder head gland, and remove from cylinder barrel.
- (6). Attach a suitable pulling device to the cylinder rod port block end or cylinder rod end, as applicable.

#### IMPORTANT

**EXTREME CARE SHOULD BE TAKEN WHEN REMOVING THE CYLINDER ROD, HEAD, AND PISTON. AVOID PULLING THE ROD OFF-CENTER, WHICH COULD CAUSE DAMAGE TO THE PISTON AND CYLINDER BARREL SURFACES.**

- (7). With the barrel clamped securely, apply pressure to the rod pulling device and carefully withdraw the complete rod assembly from the cylinder barrel.
- (8). Using suitable protection, clamp the cylinder rod in a vise or similar holding fixture as close to the piston as possible.
- (9). Remove the set screw(s), if applicable, and nut which attach the piston to the rod, and remove the piston. Discard self-locking set screws.
- (10). Remove the piston rings.
- (11). Remove and discard the piston o-rings, seal rings, and backup rings.
- (12). Remove the set screw, if applicable, piston spacer, and wear ring, if applicable, from the rod.
- (13). Remove the rod from the holding fixture. Remove the cylinder head gland and retainer, if applicable. Discard the o-rings, back-up rings, rod seals, and wiper seals.

#### b. Cleaning and Inspection.

- (1). Clean all parts thoroughly in an approved cleaning solvent.

- (2). Inspect the cylinder rod for scoring, tapering, ovality, or other damage. If necessary, dress rod with Scotch Brite or equivalent. Replace rod if necessary.
- (3). Inspect threaded portion of rod for excessive damage. Dress threads as necessary.
- (4). Inspect inner surface of cylinder barrel tube for scoring or other damage. Check inside diameter for tapering or ovality. Replace if necessary.
- (5). Inspect threaded portion of barrel for damage. Dress threads as necessary.
- (6). Inspect piston surface for damage and scoring and for distortion. Dress piston surface or replace piston as necessary.
- (7). Inspect seal and o-ring grooves in piston for burrs and sharp edges. Dress applicable surfaces as necessary.
- (8). Inspect cylinder head inside diameter for scoring or other damage and for ovality and tapering. Replace as necessary.
- (9). Inspect seal and o-ring grooves in head for burrs and sharp edges. Dress applicable surfaces as necessary.
- (10). If applicable, inspect cylinder head retainer or end cap for surface or thread damage. Repair or replace as necessary.
- (11). Inspect cylinder head outside diameter for scoring or other damage and ovality and tapering. Replace as necessary.
- (12). If applicable, inspect thread ring for scoring or other damage. Dress threads or applicable surfaces as necessary.
- (13). If applicable, inspect rod and barrel bushings for signs of correct lubrication and excessive wear. Replace as necessary.
- (14). Inspect travel limiting collar or spacer for burrs and sharp edges. If necessary, dress inside diameter surface with Scotch Brite or equivalent.
- (15). If applicable, inspect port block fittings and holding valve. Replace as necessary.
- (16). Inspect the oil ports for blockage or the presence of dirt or other foreign material. Repair as necessary.
- (17). If applicable, inspect piston rings for cracks or other damage. Replace as necessary.

### c. Assembly.

#### Notes

Prior to cylinder assembly, ensure that the proper cylinder seal kit is used. Refer to Sections 11 and 13 of this manual.

Apply a light film of hydraulic oil to all components prior to assembly.

#### IMPORTANT

**WHEN INSTALLING NEW "POLY-PAK" TYPE PISTON SEALS, ENSURE SEALS ARE INSTALLED PROPERLY. REFER TO FIGURE 2-1 FOR CORRECT SEAL ORIENTATION. IMPROPER SEAL INSTALLATION COULD RESULT IN CYLINDER LEAKAGE AND IMPROPER CYLINDER OPERATION.**

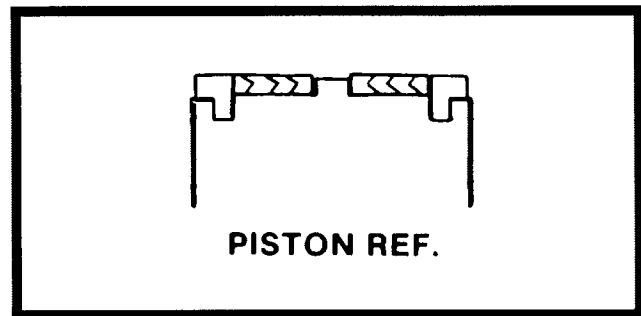

Figure 8-1. Poly-Pak Seal Installation.

- (1). Place a new wiper seal and rod seal into the applicable cylinder head gland grooves.
- (2). Carefully install the head gland on the rod, ensuring that the wiper and rod seals are not damaged or dislodged. Push the head along the rod to the rod end, as applicable.
- (3). Carefully slide the piston spacer on the rod. If applicable, align the oil holes in the rod and the spacer. Secure the spacer, if applicable.
- (4). If applicable, correctly place a new o-ring and back-up rings in the inner piston diameter groove.
- (5). Carefully place the piston on the cylinder rod, ensuring that the o-ring and back-up rings are not damaged or dislodged.
- (6). Using suitable protection, clamp the cylinder rod in a vise or similar holding fixture as close to the piston as possible.

- (7). Push the piston onto the rod until it abuts the spacer end and install the attaching nut.

**WARNING**

**IF CYLINDER IS EQUIPPED WITH A PISTON NUT, APPLY "LOCQUIC PRIMER T" AND LOCTITE #242 TO PISTON NUT THREADS, THEN TIGHTEN NUT TO TORQUE SHOWN IN TABLE 8-1.**

**Note**

**Self-locking setscrews used on piston nuts should be discarded and replaced whenever they are removed.**

**Table 8-1. Cylinder Piston Nut Torque Specifications.**

Description	Nut Torque Value (w/Loctite)	Setscrew Torque Value (w/o Loctite)
Lift Cylinder	542 Nm	11 Nm
Traversing Cylinder (If Equipped)	68 Nm	11 Nm

- (8). If applicable, torque the piston nut to the proper torque as outlined in Table 8-1. Spot drill the piston rod at the point where the setscrew is inserted into the piston nut. Install the setscrew(s) which secure the piston attaching nut to the cylinder rod.
- (9). Remove the cylinder rod from the holding fixture.
- (10). Place new o-rings and seals in the applicable outside diameter grooves of both the piston and the cylinder head.
- (11). Position the cylinder barrel in a suitable holding fixture.

**IMPORTANT**

**EXTREME CARE SHOULD BE TAKEN WHEN INSTALLING THE CYLINDER ROD, HEAD, AND PISTON. AVOID PULLING THE ROD OFF-CENTER, WHICH COULD CAUSE DAMAGE TO THE PISTON AND CYLINDER BARREL SURFACES.**

- (12). With the barrel clamped securely, and while adequately supporting the rod, insert the piston end into the barrel cylinder. Ensure that the piston loading o-ring and seal ring are not damaged or dislodged.
- (13). Continue pushing the rod into the barrel until the cylinder head gland can be inserted into the cylinder barrel.

- (14). If applicable, secure the cylinder head retainer using a suitable spanner type wrench.
- (15). After the cylinder has been reassembled, the rod should be pushed all the way in (fully retracted) prior to the reinstallation of any holding valve or valves.
- (16). If applicable, install the cartridge-type holding valve and fittings in the port block using new o-rings as applicable. Torque the holding valve in accordance with Table 8-2.

**Table 8-2. Holding Valve Torque Specifications.**

Description	Torque Value
Sun - 7/8 hex M20 x 1.5 thds	41-48 Nm
Sun - 1-1/8 hex 1-14 UNS thds	61-68 Nm
Sun - 1-1/4 hex M36 x 2 thds	204-217 Nm
Racine - 1-1/8 hex 1-1/16 - 12 thds	68-75 Nm
Racine - 1-3/8 hex 1-3/16 - 12 thds	102-109 Nm
Racine - 1-7/8 hex 1-5/8 - 12 thds	136-149 Nm

**8-11. BRAKE CYLINDER REPAIR.**

**(See Figure 8-2.)**

**a. Disassembly.**

**IMPORTANT**

**DISASSEMBLY OF THE CYLINDER SHOULD BE PERFORMED ON A CLEAN WORK SURFACE IN A DIRT FREE WORK AREA.**

- (1). Tag and disconnect the hoses from the cylinder ports.
- (2). Place the cylinder barrel (2) into a suitable holding fixture.

**WARNING**

**THE BRAKE CYLINDER IS EQUIPPED WITH AN INTERNAL COMPRESSION SPRING (1), WHICH HAS A FORCE OF APPROXIMATELY 15 KG WHEN COMPRESSED. USE EXTREME CAUTION WHEN REMOVING RETAINING RING (14) FROM CYLINDER BARREL.**

- (3). Using a suitable pair of snap ring pliers, carefully remove the retaining ring (14) from the cylinder barrel. Use extreme caution when removing the retaining ring, as the internal compression spring (1) is under a tension of approximately 15 kg.
- (4). Attach a suitable pulling device to the cylinder rod end.

**IMPORTANT**

**EXTREME CARE SHOULD BE TAKEN WHEN REMOVING THE CYLINDER ROD, HEAD, AND PISTON. AVOID PULLING THE ROD OFF-CENTER, WHICH COULD CAUSE DAMAGE TO THE PISTON AND CYLINDER BARREL SURFACES.**

- (5). With the barrel clamped securely, apply pressure to the rod pulling device and carefully withdraw the complete rod assembly from the cylinder barrel.
- (6). Using suitable protection, clamp the cylinder rod (15) in a vise or similar holding fixture.
- (7). Remove the socket head bolt (4) securing the spacer (3) to the cylinder rod and remove the spacer.
- (8). Remove the piston (8) from the cylinder rod. Remove and discard the piston ring (6) and o-rings (5 and 7).
- (9). Carefully remove the head (12) from the cylinder rod. Remove and discard the o-ring (9), backup ring (10), rod seal (11), and wiper seal (13).
- (10). Remove the cylinder rod from the holding fixture.

**b. Cleaning and Inspection.**

- (1). Clean all parts thoroughly in an approved cleaning solvent.
- (2). Inspect the cylinder rod for scoring, tapering, ovality, or other damage. If necessary, dress rod with Scotch Brite or equivalent. Replace rod if necessary.
- (3). Inspect threaded portion of rod for excessive damage. Dress threads as necessary.
- (4). Inspect inner surface of cylinder barrel tube for scoring or other damage. Check inside diameter for tapering or ovality. Replace if necessary.
- (5). Inspect piston surface for damage and scoring and for distortion. Dress piston surface or replace piston as necessary.
- (6). Inspect seal and o-ring grooves in piston for burrs and sharp edges. Dress applicable surfaces as necessary.
- (7). Inspect cylinder head inside diameter for scoring or other damage and for ovality and tapering. Replace as necessary.

- (8). Inspect seal and o-ring grooves in head for burrs and sharp edges. Dress applicable surfaces as necessary.
- (9). Inspect cylinder head outside diameter for scoring or other damage and ovality and tapering. Replace as necessary.
- (10). Inspect spacer for burrs and sharp edges. If necessary, dress spacer surface with Scotch Brite or equivalent.
- (11). Inspect the oil ports for blockage or the presence of dirt or other foreign material. Repair as necessary.

**c. Assembly.****Notes**

**Prior to cylinder assembly, ensure that the proper cylinder seal kit is used. Refer to Sections 11 and 13 of this manual.**

**Apply a light film of hydraulic oil to all components prior to assembly.**

- (1). Using suitable protection, clamp the cylinder rod in a vise or similar holding fixture.
- (2). Place a new wiper seal (13), rod seal (11), o-ring (9), and back-up ring (10) into the applicable cylinder head grooves.
- (3). Carefully install the head on the rod, ensuring that the wiper and rod seals are not damaged or dislodged. Push the head onto the rod.
- (4). Place a new piston ring (6) and o-rings (5 and 7) on the piston.
- (4). Carefully place the piston on the cylinder rod, ensuring that the o-ring is not damaged or dislodged. Push the piston onto the rod until it abuts the head.
- (5). Install the spacer (3) on the end of the cylinder rod and secure in place with the socket head bolt (4).
- (6). Remove the cylinder rod from the holding fixture.
- (7). Position the cylinder barrel in a suitable holding fixture.

**IMPORTANT**

**EXTREME CARE SHOULD BE TAKEN WHEN INSTALLING THE CYLINDER ROD, HEAD, AND PISTON. AVOID PULLING THE ROD OFF-CENTER, WHICH COULD CAUSE DAMAGE TO THE PISTON AND CYLINDER BARREL SURFACES.**

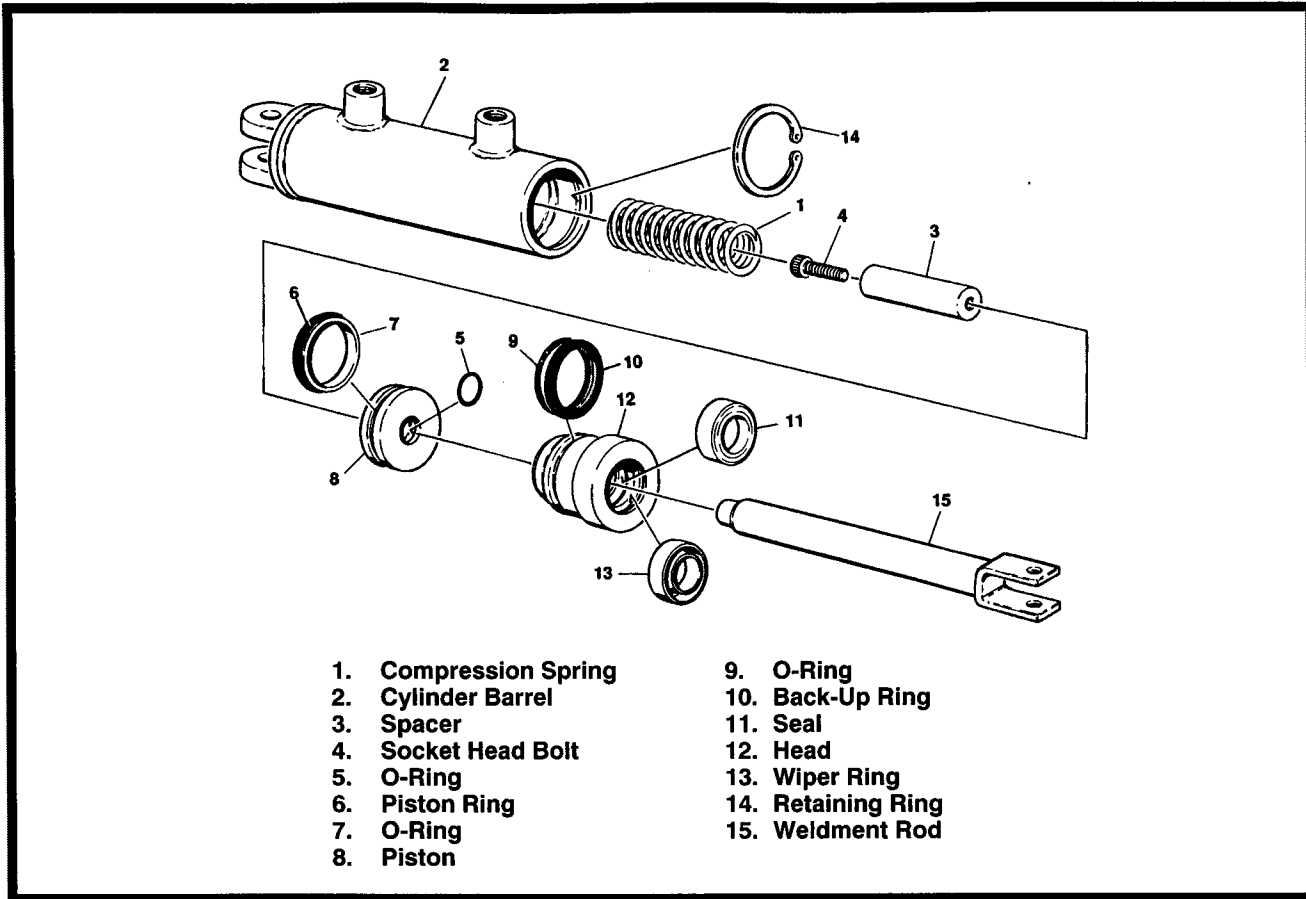

- |                       |                    |
|-----------------------|--------------------|
| 1. Compression Spring | 9. O-Ring          |
| 2. Cylinder Barrel    | 10. Back-Up Ring   |
| 3. Spacer             | 11. Seal           |
| 4. Socket Head Bolt   | 12. Head           |
| 5. O-Ring             | 13. Wiper Ring     |
| 6. Piston Ring        | 14. Retaining Ring |
| 7. O-Ring             | 15. Weldment Rod   |
| 8. Piston             |                    |

Figure 8-2. Brake Cylinder Assembly.

- (12). Install the compression spring (1) on the piston end of the cylinder rod. With the barrel clamped securely, and while adequately supporting the rod, insert the piston end into the barrel cylinder. Ensure that the piston ring and o-ring are not damaged or dislodged.
- (13). Continue pushing the rod into the barrel until the cylinder head can be inserted into the cylinder barrel.
- (14). Using all applicable safety precautions, secure the cylinder rod assembly with a new retaining ring (14).
- (15). Reconnect the hydraulic hoses to the applicable cylinder ports.

tions cut out Drive forward and reverse and Lift Up functions when the switch is activated. Consult factory for tilt sensor adjustment. The only field adjustment necessary is leveling the switch on the spring loaded studs. There are two methods of adjustment, a manual adjustment and an adjustment using a voltmeter.

**CAUTION**

**PERFORM TILT ALARM SWITCH LEVELING PROCEDURE A MINIMUM OF EVERY SIX MONTHS TO ENSURE PROPER OPERATION AND ADJUSTMENT OF SWITCH.**

**a. Manual Adjustment.**

- (1). Park the machine on a flat, level surface and ensure machine is level.

**Note**

**Ensure switch mounting bracket is level and securely attached.**

- (2). Level the base of the indicator by tightening the three flange nuts. Tighten each nut through approximately one half of it's spring's travel. **DO NOT ADJUST THE "X" NUT DURING THE REMAINDER OF THE PROCEDURE.**

**8-12. TILT ALARM SWITCH.**

**Note**

The machine is equipped with a tilt alarm switch (sensor), factory set to activate when the machine is out of level 3 degrees in any direction. When activated, the switch will illuminate a light on the platform and activate a warning horn if the platform is raised. When the switch is activated with the platform lowered, only the light is illuminated. Machines built to French specifica-

- (3). With the electrical connections complete, slowly tighten one of the "Y" nuts until the circuit is closed and the light on the Platform Control Console illuminates.
- (4). Slowly back off the nut, counting the number of turns, until the circuit is again closed and the light again illuminates.
- (5). Divide the number of turns determined in step (4) in half. Tighten the nut this many turns. The line determined by this nut and the "X" nut is now parallel to the ground.
- (6). Repeat steps (3) through (5) for the remaining "Y" nut. The switch is now level.
- (7). Individually push down on one corner at a time; there should be enough travel to cause the switch to trip. If the switch does not trip in all three tests, the flange nuts have been tightened too far. Loosen the "X" nut and repeat steps (3) through (7).

**b. Voltmeter Adjustment. (See Figure 8-3.)**

- (1). Park machine on a flat, level surface and ensure machine is level.
- (2). If motor is not running, turn ignition switch to ON.
- (3). Connect black lead of voltmeter to ground and red lead to yellow wire protruding from pot on bottom of sensor.

- (4). Adjust leveling nuts to obtain the highest possible voltage reading.
- (5). Check voltage at trip point in all four directions. If voltage reading is not symmetrical, repeat step (4) above.

**8-13. LIMIT SWITCH ADJUSTMENTS.**

**a. High Drive Limit Switch.**

The High Drive Speed limit switch is located on the front of the frame of the machine. The switch is activated when the platform is raised above the stowed position. When activated, the switch cuts out the High Drive function. On machines built to Italian specifications, this switch cuts out the Drive function when the platform is raised above the stowed position.

**b. Drive Limit Switch.**

The Drive limit switch is located on the front of the frame of the machine. When activated, the switch cuts out the Drive function. On models CM1432 and CM1432 Plus, the switch is activated when the platform is raised above 2.7 meters. On model CM1732, the switch is activated when the platform is raised above 3 meters. On models CM2033 and CM2046, the switch is activated when the platform is raised above 5 meters. On models CM2546 and CM2558, the switch is activated when the platform is raised above 6.4 meters. Machines built to Italian specifications cut-out Drive function when platform is raised above stowed position.

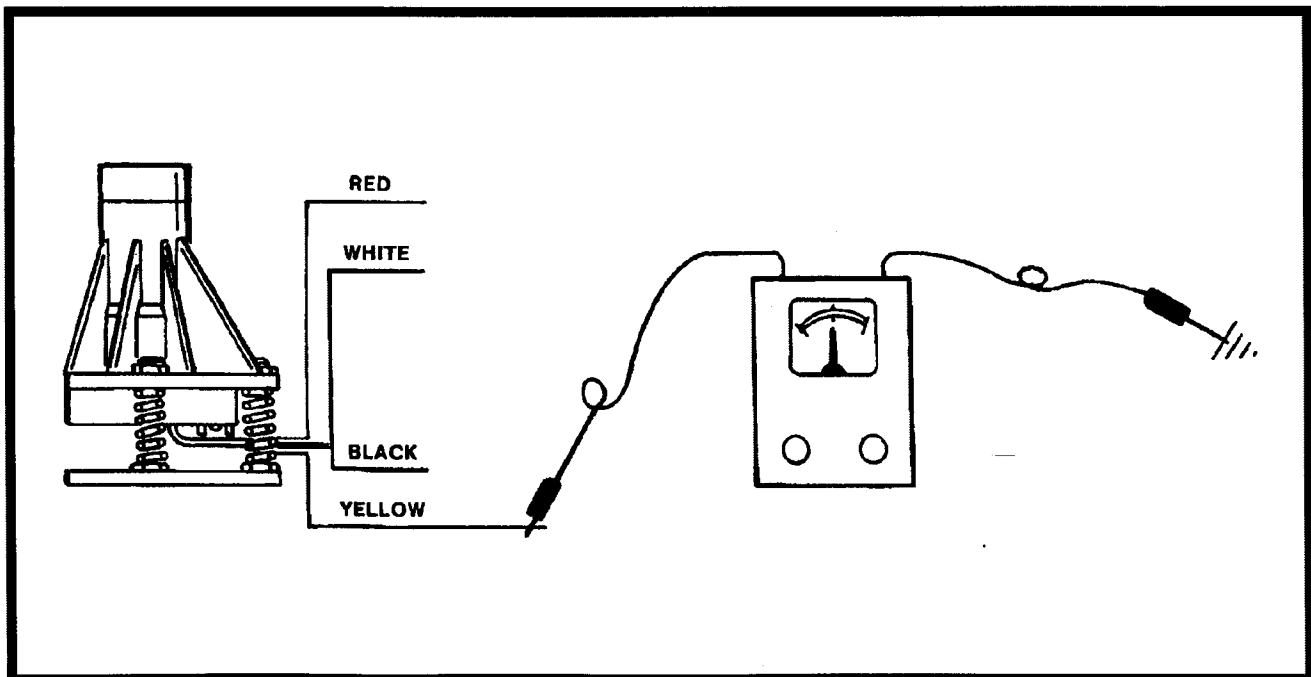

Figure 8-3. Tilt Alarm Switch Leveling - Voltmeter Adjustment.

**8-14. PRESSURE SETTING PROCEDURES.**  
(See Figures 8-4 and 8-5.)

**Notes**

Make all pressure adjustments with motor operating and hydraulic oil at normal operating temperature.

Drive is governed by P1. Steer and High Drive are governed by P2. On machines built before June 1993, Lift is controlled by P2. On machines built after June 1993, a separate Lift relief valve is provided.

**a. Drive Relief Adjustment.**

- (1). Install two pressure gauges, one at gauge port G1 and one at gauge port G2, by installing fittings in valve. G1 and G2 are located adjacent to the steer reliefs, and are identified by stampings on the valve body.
- (2). Disconnect tee fitting from drive tube (M3). Plug and cap tube and tee fitting.
- (3). Energize High Drive, Mid Drive and Drive Forward by positioning High Drive switch to HIGH and activate Drive switch to Drive Forward or by activating Drive controller to Drive Forward.

- (4). On machine with bang-bang drive, adjust P1 to 186 bar. On machines with proportional drive, adjust P1 to 186 bar.
- (5). Replace tee fitting to drive tube.

**b. Main Relief Adjustment.**

**Note**

Machines built after June 1993 are equipped with a separate Lift relief valve. On these machines, before adjusting main relief, turn the Lift relief valve adjustment all the way in (clockwise).

- (1). Activate Lift Up function and bottom out Lift Up.
- (2). Adjust P2 to 186 bar.
- (3). Adjust Lift Down Speed Adjustment valve to 25-30 seconds for models CM1432, CM1432 Plus, CM1732, CM2033, and CM2046, and 30-35 seconds for models CM2546 and CM2558.

**c. Lift Relief Adjustment.**

**(Machines Built After June 1993 Only.)**

- (1). Activate Lift Up function and bottom out Lift Up.

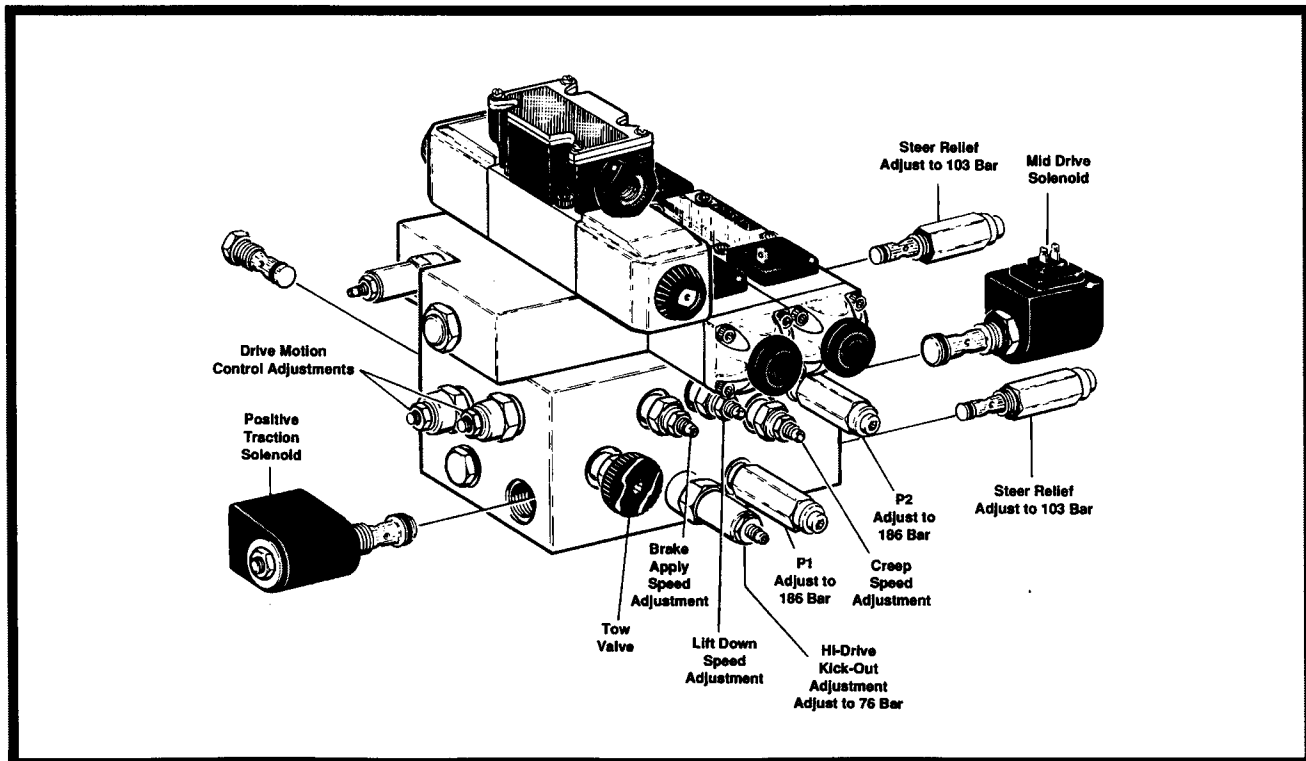

Figure 8-4. Pressure Adjustment Locations - Proportional Valve.



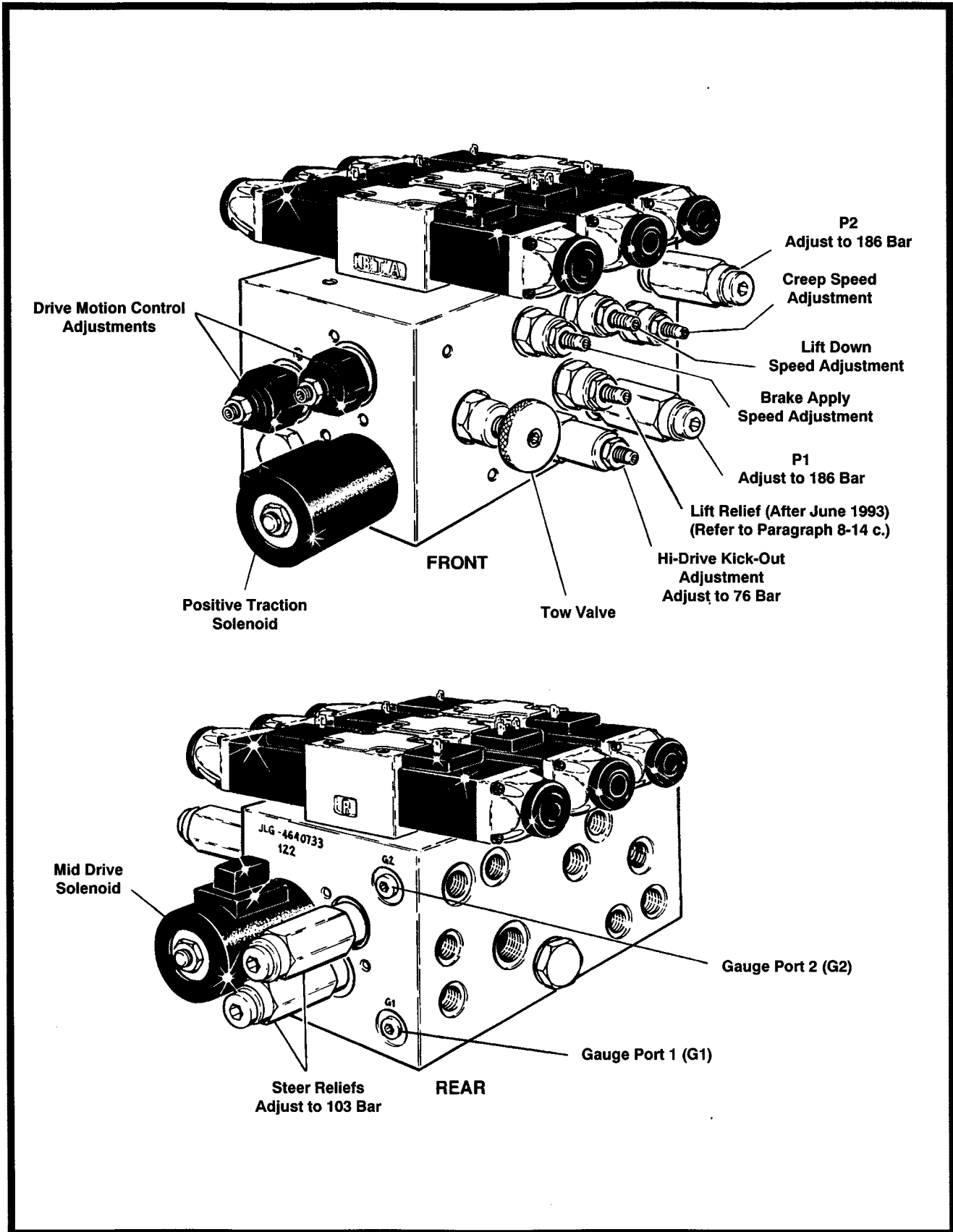

Figure 8-5. Pressure Adjustment Locations - Bang-Bang Valve.

- (2). Adjust Lift relief valve as follows:  
 CM1432 - 152 bar.  
 CM1432 Plus - Consult Factory.  
 CM1732 - 159 bar.  
 CM2033 - 124 bar.  
 CM2046 - 148 bar.  
 CM2546 - 141 bar.  
 CM2558 - 159 bar.

**d. High Drive Adjustment.**

- (1). While monitoring pressure gauge at G2, active High Drive and traverse grade until High Drive shifts out. Adjust valve in until gauge at G2 reads 76 bar shifting in and out on grade. Stop at this point and lock adjustment screw.

**e. Steer Relief Adjustment.**

- (1). While monitoring pressure gauge at G2, bottom out Steer Left and adjust S1 to 103 bar.
- (2). While monitoring pressure gauge at G2, bottom out Steer Right and adjust S2 to 103 bar.

**Note**

**OC1 and OC2 are set at factory. If not functioning properly, they must be replaced.**

**8-15. PREVENTIVE MAINTENANCE AND INSPECTION SCHEDULE.**

- a.** The preventive maintenance and inspection checks are listed and defined in the following table. This table is divided into two basic parts, the "AREA" to be inspected and the "INTERVAL" at which the inspection is to take place. Under the "AREA" portion of the table, the various systems along with the components that make up that system are listed. The "INTERVAL" portion of the table is divided into five columns representing the various inspection time periods. The numbers listed within the interval column represent the applicable inspection code for which that component is to be checked.
- b.** The checks and services listed in this schedule are not intended to replace any local or regional regulations that may pertain to this type of equipment nor should the lists be considered as all inclusive. Variances in interval times may occur due to climate and/or conditions and depending on the location and use of the machine.
- c.** JLG Industries requires that a complete annual inspection be performed in accordance with the "Annual Machine Inspection Report" form. Forms are supplied with each new machine and are also available from JLG Customer Service. Form must be completed and returned to JLG Industries.

**IMPORTANT**

**JLG INDUSTRIES REQUIRES THAT A COMPLETE ANNUAL INSPECTION BE PERFORMED IN ACCORDANCE WITH THE "ANNUAL MACHINE INSPECTION REPORT" FORM.**

**Note**

**This machine requires periodic safety and maintenance inspections be a JLG Dealer.**

**d. The inspection and maintenance code numbers are as follows:**

1. Check for proper and secure installation.
2. Check for visible damage and legibility.
3. Check for proper fluid level.
4. Check for any structural damage; cracked or broken welds; bent or warped surfaces.
5. Check for leakage.
6. Check for presence of excessive dirt or foreign material.
7. Check for proper operation and freedom of movement.
8. Check for excessive wear or damage.
9. Check for proper tightness and adjustment.
10. Drain, clean and refill.
11. Check for proper operation while pump/motor is running.
12. Check for proper lubrication.
13. Check for evidence of scratches, nicks or rust and for straightness of rod.
14. Check for condition of element; replace as necessary.
15. Check for proper inflation.
16. Check Inspection Decal for current inspection stamp.

Table 8-2. Preventive Maintenance and Inspection Schedule.

PREVENTIVE MAINTENANCE AND INSPECTION SCHEDULE					
AREA	INTERVAL				
PLATFORM	(10 HRS) DAILY	(50 HRS) WEEKLY	(200 HRS) MONTHLY	(500 HRS) 3 MONTH	(1000 HRS) 6 MONTH
1. Controller (If Equipped)	1,11				
2. Switches	1,11				
3. Placards and Decals	1,2				
4. Control Tags	1,2				
5. Hoses and Cables	1	4,8			
6. Wear Pads			8		
7. Handrail and Chains	1,4				
<b>CHASSIS</b>					
1. Batteries	3	5			
2. Battery Charger	1				
3. Hydraulic Pump/Motor	1	5			
4. Valves	1	5			
5. Hydraulic Filter (See Lubrication Chart)		5,14	14		
6. Hydraulic Hoses and Tubing	1	5			
7. Hydraulic Oil Tank *	3	5	4		
8. Hydraulic Tank Breather		6,14			
9. Lift Cylinder	1,12	5,6,13	4		
10. Limit Switches	1,7				
11. Placards and Decals	1,2				15
12. Wheel and Tire Assemblies	1	8,9			
13. Drive Motors		1,5,6			
14. Drive Brake		1,6	8		
15. Steer Cylinder	1	5,6,13	4		
16. Steer Components	1	4,6	8		
17. Wheel Bearings			8	12	
18. Sizzor Arms	1,4				
19. Safety Prop	1,4				
20. Wear Pads			8		
21. Pivot Pins/Bolts	1,4		7,8		
22. Switches, Ground Control	1,11				
23. Control Tags	1,2				
24. Placards and Decals	1,2				
25. Hoses and Cables	1	4,8			

\* Inspection and Maintenance Code 10 to be performed annually.



### 9-1. GENERAL.

This section contains troubleshooting information to be used for locating and correcting most of the operating problems which may develop in the aerial platform. If a problem should develop which is not presented in this section or which is not corrected by listed corrective actions, technically qualified guidance should be obtained before proceeding with any maintenance.

### 9-2. TROUBLESHOOTING INFORMATION.

- a. The troubleshooting procedures applicable to the aerial platform are listed and defined in Tables 9-1 through 9-4. As an aid to table use, the aerial platform is divided into four major groups, each covered separately within this section. These groups are as follows: platform elevation system, chassis, hydraulic system and electrical system.
- b. Each malfunction within an individual group or system is followed by a listing of probable causes which will enable determination of the applicable remedial action. The probable causes and the remedial action should, where possible, be checked in the order listed in the tables.
- c. It should be noted that there is no substitute for a thorough knowledge of the equipment and related systems.

- d. It should be recognized that the majority of the problems arising in the machine will be centered in the hydraulic and electrical systems. For this reason, every effort has been made to ensure that all likely problems in these areas are given the fullest possible treatment. In the remaining machine groups, only those problems which are symptomatic of greater problems which have more than one probable cause and remedy are included. This means that problems for which the probable cause and remedy may be immediately obvious are not listed in this section.
- e. The first rule for troubleshooting any circuit that is hydraulically operated and electrically controlled is to determine if the circuit is lacking hydraulic oil and electrical control power. This can be ascertained by overriding the bypass valve (mechanically or electrically) so that oil is available to the function valve, then overriding the function valve mechanically. If the function performs satisfactorily, the problem exists with the control circuit.

### 9-3. HYDRAULIC CIRCUIT CHECKS.

The first reference for improper function of a hydraulic system, where the cause is not immediately apparent, should be the Troubleshooting Chart. The best place to begin the problem analysis is at the power source (pump). Once it is determined that the pump is serviceable, then a systematic check of the circuit components, beginning with the control, would follow. For aid in troubleshooting, refer to Sections 11 and 13, the Illustrated Parts Lists, for hydraulic diagrams of the various circuits.

Table 9-1. Elevation System Troubleshooting.

<b>TROUBLE</b>	<b>PROBABLE CAUSE</b>	<b>REMEDY</b>
<b>Platform Elevation System.</b>		
No response to LIFT control switch.	ENABLE switch not activated.	Activate ENABLE switch.
	LIFT control switch not activated within three seconds after ENABLE switch is activated.	Re-activate ENABLE switch.
	ENABLE switch not functioning properly.	Replace ENABLE switch circuit card.
	Lift control switch inoperative.	Repair or replace control switch.
	Hydraulic system oil low.	Replenish oil as necessary.
	Restricted or broken supply line on valve bank or hydraulic pump.	Clean, repair or replace line.
	Control valve not functioning properly.	Repair or replace valve.
	Lift cylinder not functioning properly.	Repair or replace cylinder.
	Hydraulic pump not functioning properly.	Repair or replace pump.
	Platform overloaded. (French Specification.)	Correct overload condition.
Platform will not raise.	ENABLE switch not activated.	Activate ENABLE switch.
	LIFT control switch not activated within three seconds after ENABLE switch is activated.	Re-activate ENABLE switch.
	ENABLE switch not functioning properly.	Replace ENABLE switch circuit card.
	Load capacity exceeded. (Personnel and/or equipment on platform.)	Reduce load. (Refer to capacity placard.)
	Hydraulic system oil low.	Replenish oil as necessary.
	Restricted or broken hydraulic line or fitting.	Clean, repair, or replace line or fitting.
	Control valve not functioning properly.	Repair or replace valve.
	Lift cylinder not functioning properly.	Repair or replace cylinder.
	Motor/Pump does not respond when LIFT control switch is moved to UP position.	Refer to Electrical System Troubleshooting Chart. No response to control switch.
	No electrical signal being sent to LIFT UP control valve cartridge.	Refer to Electrical System Troubleshooting Chart. No response to control switch.
Platform will not lower.	ENABLE switch not activated.	Activate ENABLE switch.
	LIFT control switch not activated within three seconds after ENABLE switch is activated.	Re-activate ENABLE switch.
	ENABLE switch not functioning properly.	Replace ENABLE switch circuit card.

Table 9-1. Elevation System Troubleshooting.

TROUBLE	PROBABLE CAUSE	REMEDY
<b>Platform Elevation System. (cont.)</b>		
Platform will not lower. (cont.)	No electrical signal sent to LIFT DOWN control valve cartridge.	Refer to Electrical System Troubleshooting Chart. No response to control switch.
	LIFT DOWN control valve cartridge not functioning properly.	Repair or replace LIFT DOWN control valve cartridge.
	Lift cylinder not functioning properly.	Repair or replace cylinder.
	Motor/Pump does not respond when LIFT control switch is moved to DOWN position.	Refer to Electrical System Troubleshooting chart. No response to control switch.
	No electrical signal being sent to LIFT DOWN control valve	Refer to Electrical System Troubleshooting chart. No response to control switch.
Platform raises and lowers erratically.	Hydraulic system oil low.	Replenish oil as required.
	Restricted or broken hydraulic line or fitting.	Clean or replace line.
	Lack of lubricant on lift cylinder attach pins.	Lubricate as required. (Refer to Lubrication Chart)
	Counterbalance valve on lift cylinder improperly adjusted or not functioning properly.	Replace valve.
	Control valve not functioning properly.	Repair or replace valve.
	Worn seals in lift cylinder.	Replace seals.
	Cylinder not functioning properly.	Repair or replace cylinder.
Platform drifts down.	Manual lowering valve not functioning properly.	Repair or replace valve.
	Worn seals in lift cylinder.	Replace seals.
	Holding valve on lift cylinder not functioning properly.	Repair or replace valve.
	Drive does not operate below 2.7 meters on Models CM1432 and CM1432 Plus.	Damaged wire on limit switch.
Damaged limit switch.		Replace limit switch.
Drive does not operate below 3 meters on Model 1732.	Damaged wire on limit switch.	Repair or replace wiring.
	Damaged limit switch.	Replace limit switch.
Drive does not operate below 5 meters on Models CM2033 and CM2046.	Damaged wire on limit switch.	Repair or replace wiring.
	Damaged limit switch.	Replace limit switch.
Drive does not operate below 6.4 meters on Models CM2546 and CM2558.	Damaged wire on limit switch.	Repair or replace wiring.
	Damaged limit switch.	Replace limit switch.
Drive does not operate below horizontal. (Italian Specification.)	Damaged wiring on limit switch.	Repair or replace wiring.
	Damaged limit switch.	Replace limit switch.
High Drive does not operate when platform is completely lowered.	Damaged wiring on limit switch.	Repair or replace wiring.
	Damaged limit switch.	Replace limit switch.

Table 9-2. Chassis Troubleshooting.

TROUBLE	PROBABLE CAUSE	REMEDY
<b>Drive System.</b>		
No response to DRIVE control switch or controller.	ENABLE switch not activated.	Activate ENABLE switch.
	DRIVE control switch or controller not activated within three seconds after ENABLE switch is activated.	Re-activate ENABLE switch.
	ENABLE switch not functioning properly.	Replace ENABLE switch circuit card.
	Hydraulic system oil low.	Replenish oil as necessary.
	Hydraulic pump not functioning properly.	Repair or replace pump.
	Restricted or broken pump supply line.	Clean, repair or replace line.
	Drive motor(s) not functioning properly.	Repair or replace motor(s).
	Damaged wiring on DRIVE control switch or controller.	Repair or replace wiring.
	DRIVE control switch or controller not functioning properly.	Replace switch.
	Drive brake not releasing.	Determine cause and repair or replace brake.
Machine drives erratically. (PQ Controller Drive.)	Microswitch on controller improperly adjusted.	Adjust microswitch on controller for proper operation.
Machine will not travel forward.	ENABLE switch not activated.	Activate ENABLE switch.
	DRIVE control switch or controller not activated within three seconds after ENABLE switch is activated.	Re-activate ENABLE switch.
	ENABLE switch not functioning properly.	Replace ENABLE switch circuit card.
	Hydraulic system oil low.	Replenish oil as necessary.
	Restricted or broken hydraulic line or fitting.	Clean, repair or replace line or fitting.
	Control valve not functioning properly.	Repair or replace valve.
	Drive motor(s) not functioning properly.	Repair or replace motor(s).
	Brake cylinder not functioning properly.	Repair or replace brake cylinder.
	Motor/Pump will not respond when DRIVE control is moved to FORWARD position.	Refer to Electrical System Troubleshooting Chart. No response to control switch.
	No electrical signal being sent to the Drive valve cartridge.	Refer to Electrical System Troubleshooting Chart. No response to control switch.
Machine will not travel in reverse.	See: Machine will not travel forward.	



Table 9-2. Chassis Troubleshooting.

TROUBLE	PROBABLE CAUSE	REMEDY
<b>Drive System. (continued)</b>		
High-Speed Drive function does not operate. (Toggle Switch Drive)	Loose or damaged wiring between DRIVE control and High Speed switch.	Ensure proper connection of wires. Using suitable test meter, perform continuity test on wiring between switches. Repair or replace wires as necessary.
	Defective high speed control switch.	Replace switch.
	Loose or damaged wire in control box wire harness.	Ensure proper connection of wire at the control switch. Using suitable test meter, perform continuity test on wire. Repair or replace harness as necessary.
	Loose or damaged wire between platform and high speed solenoid.	Ensure proper connection of wire at the platform and at the high speed solenoid. Using suitable test meter, perform continuity test on wire. Repair or replace harness as necessary.
	High speed solenoid not functioning properly.	Replace solenoid.
	Loose or damaged wires between high speed relay and high speed limit switch.	Ensure proper connection of wires between high speed relay and high speed limit switch. Using suitable test meter, perform continuity test on wires. Repair or replace wires as necessary.
	High speed limit switch not functioning properly.	Repair or replace limit switch.
	Loose or damaged wire in valve wiring harness.	Ensure proper connection of wires at terminal strip. Using suitable test meter, perform continuity test on wires. Repair or replace harness as necessary.
	Motor/pump assembly defective.	Replace motor/pump assembly.

Table 9-2. Chassis Troubleshooting.

TROUBLE	PROBABLE CAUSE	REMEDY
<b>Steering System.</b>		
No response to STEER control switch or controller.	ENABLE switch not activated.	Activate ENABLE switch.
	STEER control switch or controller not activated within three seconds after ENABLE switch is activated.	Re-activate ENABLE switch.
	ENABLE switch not functioning properly.	Replace ENABLE switch circuit card.
	Hydraulic system oil low.	Replenish oil as necessary.
	Hydraulic system pressure too low.	Adjust pressure.
	Damaged wiring on control switch or solenoid valve.	See proper wiring diagram.
	STEER control switch or controller not functioning properly.	Replace switch.
	Restricted or broken hydraulic line on valve bank or hydraulic pump.	Clean, repair or replace line.
	Control valve not functioning properly.	Repair or replace valve.
	Steer cylinder not functioning properly.	Repair or replace cylinder.
Machine hard to steer or steering is erratic.	Hydraulic system oil low.	Replenish oil as necessary.
	Restricted hydraulic line or fitting.	Clean, repair or replace line or fitting.
	Lack of lubrication.	Lubricate as required. (Refer to Lubrication Chart.)
	Restricted crossover relief valve.	Clean or replace valve.
	Steer system pressure low.	Adjust pressure.
	Bent steering linkage.	Repair or replace linkage as required.
	Hydraulic pump not functioning properly.	Repair or replace pump.
	Steer cylinder not functioning properly.	Repair or replace cylinder.
Steering inoperative.	ENABLE switch not activated.	Activate ENABLE switch.
	STEER control switch or controller not activated within three seconds after ENABLE switch is activated.	Re-activate ENABLE switch.
	ENABLE switch not functioning properly.	Replace ENABLE switch circuit card.
	Damaged wiring on control switch or solenoid valve.	See proper wiring diagram.
	Solenoid valve not functioning properly.	Repair or replace valve.
	STEER control switch or controller not functioning properly.	Replace switch.
	Relief valve improperly set or not functioning properly.	Reset, repair or replace valves as required.
	Steer cylinder not functioning properly.	Repair or replace cylinder.

Table 9-2. Chassis Troubleshooting.

TROUBLE	PROBABLE CAUSE	REMEDY	
<b>Steering System. (cont.)</b>			
Machine will not steer left or right.	ENABLE switch not activated.	Activate ENABLE switch.	
	STEER control switch or controller not activated within three seconds after ENABLE switch is activated.	Re-activate ENABLE switch.	
	ENABLE switch not functioning properly.	Replace ENABLE switch circuit card.	
	Wiring on STEER control switch or controller is damaged.	Repair or replace wiring.	
	Wiring on solenoid valve damaged.	Repair or replace wiring.	
	Coil in solenoid damaged.	Replace coil.	
	Bent cylinder rod.	Repair or replace cylinder.	
	Damaged steer linkage.	Repair or replace steer linkage.	
	Machine wanders; steering not firm.	Crossover relief valve set too low or not functioning properly.	Reset, repair or replace valve as required.
		Steer linkages loose.	Tighten linkage.
Steer wheel toe-in not set properly.		Adjust toe-in for 1/4 inch overall.	
Spindle bushings badly worn.		Replace bushings.	

Table 9-3. Hydraulic System Troubleshooting.

TROUBLE	PROBABLE CAUSE	REMEDY
<b>Hydraulic System - General.</b>		
Hydraulic pump noisy.	Air bubbles in oil. (Reservoir oil too low.)	Replenish oil as required.
	Oil filter dirty.	Clean and/or replace filter as necessary.
Pump cavitating. (Vacuum in pump due to oil starvation.)	Restricted reservoir air vent.	Clean vent.
	Oil viscosity too high.	Drain system and replace with recommended oil. (Refer to Hydraulic Oils.)
System overheating.	Oil viscosity too high.	Drain system and replace with recommended hydraulic oil.
	Main relief valve set too high.	Reset valve as required.
	Hydraulic system oil low.	Replenish oil as necessary.
Pump not delivering oil.	Defective pump on motor.	Repair or replace motor.
System pressure too low.	Main relief valve set too low.	Reset valve as required.
	Hydraulic pump not functioning properly.	Repair or replace pump.
	Leak in component, line or fitting.	Repair or replace component, line or fitting.
	Scored valve spool; scored cylinder.	Replace valve; replace cylinder.
System(s) operate erratically.	Sticking or binding valve cartridge, piston rod, etc.	Clean, repair or replace components as required.
	Hydraulic oil not at operating temperature.	Allow oil sufficient time to warm up.

Table 9-4. Electrical System Troubleshooting.

TROUBLE	PROBABLE CAUSE	REMEDY
<b>Hand Controller.</b>		
Valve will not function when handle is moved in either direction.	ENABLE switch not activated.	Activate ENABLE switch.
	Controller not activated within three seconds after ENABLE switch is activated.	Re-activate ENABLE switch.
	ENABLE switch not functioning properly.	Replace ENABLE switch circuit card.
	No electrical power to handle.	Check electrical input to hand controller (12V).
	No electrical power to valve.	Check electrical output of printed circuit board and electrical signal at the valve.
	Improper ground.	Check for proper grounding of handle.
<b>Control Switches.</b>		
No response to a function control switch.	ENABLE switch not activated.	Activate ENABLE switch.
	Control switch not activated within three seconds after ENABLE switch is activated.	Re-activate ENABLE switch.
	ENABLE switch not functioning properly.	Replace ENABLE switch circuit card.
	EMERGENCY STOP switch not positioned properly.	Place EMERGENCY STOP switch to "ON".
	POWER SELECTOR switch on ground control box not positioned properly.	Place POWER SELECTOR switch to PLATFORM or GROUND, as required.
	Battery charger connected and in service.	Disconnect battery charger.
	Circuit breaker open.	Determine and correct cause. Reset circuit breaker.
	Batteries defective or require charging.	Test batteries for serviceability. Replace or charge batteries as necessary.
	No voltage present at EMERGENCY STOP switch.	Check battery cable from battery bank to EMERGENCY STOP switch for proper connection or damage. Repair or replace cable as necessary.
	EMERGENCY STOP switch not functioning properly.	Replace switch.
	No voltage supplied to electric motor start relay from EMERGENCY STOP switch.	Check battery cable from switch to relay for proper connection or damage. Repair or replace cable as necessary.
	No voltage input at terminal strip.	Check wire from battery bank to terminal strip for proper connection or damage. Repair or replace wire as necessary.

Table 9-4. Electrical System Troubleshooting.

TROUBLE	PROBABLE CAUSE	REMEDY
<b>Control Switches. (cont.)</b>		
No response to a function control switch. (cont.)	No voltage present at circuit breaker.	Check wire from terminal strip to circuit breaker for proper connection or damage. Repair or replace wire as necessary.
	Defective circuit breaker.	Replace circuit breaker.
	No voltage present at charge relay.	Check wire from charge relay to terminal strip for proper connection or damage. Repair or replace wire as necessary.
	Defective charge relay.	Replace charge relay.
	No voltage supplied to terminal strip from charge relay.	Check wire from charge relay to terminal strip for proper connection or damage. Repair or replace wire as necessary.
	No voltage present at control box EMERGENCY STOP switch.	Unplug control box harness from platform receptacle. Check wire from applicable pin in plug to control box EMERGENCY STOP switch for proper connection. Using suitable test meter, perform continuity test on wire. Repair or replace harness as necessary.
	Defective EMERGENCY STOP switch in control box.	Replace EMERGENCY STOP switch.
	No voltage present at function control switch.	Check wiring from EMERGENCY STOP switch to function control switch for proper connection or damage. Repair or replace wiring as necessary.
	Defective function control switch.	Replace function control switch.
	No voltage present at applicable points of the terminal strip. (Note: Actuation of a function control switch should simultaneously send an electrical signal to two separate points on the terminal strip. One signal for activation of the control valve coil and another signal for the activation of the electric motor start relay.)	Unplug control box harness from platform receptacle. Check applicable wires for proper connection in control box, at control box plug, at platform receptacle and at terminal strip. Using suitable test meter, perform continuity check on wires. Repair or replace harness as necessary.
	No voltage present at applicable control valve coil.	Check applicable wire for proper connection at terminal strip, valve harness plug pin, valve harness receptacle pin and valve coil. Using suitable test meter, perform continuity test on wire. Repair or replace wire or harness as necessary.
	No voltage supplied from terminal strip to electric motor start relay.	Check applicable wire for proper connection at terminal strip, valve harness plug pin, valve harness receptacle pin and electric motor start relay. Using suitable test meter, perform continuity test on wire. Repair or replace wire or harness as necessary.

Table 9-4. Electrical System Troubleshooting.

TROUBLE	PROBABLE CAUSE	REMEDY
<b>Control Switches. (cont.)</b>		
No response to a function control switch. (cont.)	Defective electric motor start relay.	Replace electric motor start relay.
	No voltage supplied to motor from start relay.	Check battery cable from relay to motor for proper connection or damage. Repair or replace cable as necessary.
	Defective motor/pump assembly.	Replace motor/pump assembly.
<b>Motor/Pump.</b>		
Hydraulic pump/electric motor inoperative.	Batteries require charging or will not hold a charge.	Charge or replace batteries as required.
	ENABLE switch not activated.	Activate ENABLE switch.
	Control switch or controller not activated within three seconds after ENABLE switch is activated.	Re-activate ENABLE switch.
	ENABLE switch not functioning properly.	Replace ENABLE switch circuit card.
	Damaged wiring on control switch.	Repair or replace wiring.
	Control switch not functioning properly.	Replace switch.
	Pump motor relay not functioning properly.	Repair or replace relay.
	Pump motor not functioning properly.	Repair or replace motor.





# SECTION 10 RECOMMENDED SERVICE PARTS STOCK

CM2033/CM2046/CM2546/CM2558

The following lists will service fleets of machines (built to current production per date on the front cover) with emergency repair parts which can be installed in the field. Parts from the list should be replaced when inventory is depleted to keep service parts stock supplied. For further information, contact your JLG dealer or the JLG Industries Parts Department.

SECTION 10 RECOMMENDED SERVICE PARTS STOCK

JLG PART NO.	DESCRIPTION	QTY. PER FLEET SIZE		
		1-4	5-9	10 or More
<b>STANDARD PARTS</b>				
4360300	Limit Switch (Figure 11-1-5)	1	1	1
4360349	Sensor, Tilt (Figure 11-1-5)	1	1	1
3740069	Relay (Figure 11-2-1)	1	1	1
3740068	Relay (Figure 11-2-1)	1	1	1
7010944	Flex Coupling Kit (Figure 11-2-1)	1	1	1
4360202	Switch, Toggle (Figure 11-2-1)	1	1	1
4360319	Switch, Keyed (Figure 11-2-1)	1	1	1
7012560	Key, Replacement (Figure 11-2-1)	1	1	1
4360267	Block, Contact (Figures 11-2-1 and 11-4-6)	1	1	1
4360281	Block, Contact (Figure 11-2-1)	1	1	1
4360070	Breaker, Circuit (Figure 11-2-1)	1	1	1
4360155	Switch, Master (Figure 11-2-1)	1	1	1
2120072	Element, Filter (Figure 11-2-1)	4	8	12
1340052	Breather, Air (Figure 11-2-1)	1	1	1
7012726	Coil - Rexroth (Figure 11-2-3 and 11-2-4)	1	1	1
7012732	Coil - Rexroth (Figure 11-2-3 and 11-2-4)	1	1	1
7012727	Coil - Rexroth (Figure 11-2-3 and 11-2-4)	1	1	1
7012900	Coil - 20 Volt (Figure 11-2-3 and 11-2-4)	1	1	1
7012934	Sequence Valve Cartridge (Figure 11-2-3 and 11-2-4)	1	1	1
2400041	Fuse - 200 Amp (Figure 11-2-5)	2	2	2
7011509	Breaker, Circuit (Figure 11-2-6 and 11-2-7)	1	1	1
7011559	Diode - 20 Amp (Figure 11-2-6 and 11-2-7)	2	2	2
4360339	Switch, Push Button (Figure 11-4-6)	1	1	1
4360289	Switch, Push/Pull (Figure 11-4-6)	1	1	1
4360318	Switch, Toggle (Figure 11-4-6)	1	1	1
4360274	Switch, Push Button (Figure 11-4-6)	1	1	1
7012658	Fuse - 7.5 Amp (Figure 11-4-6)	2	2	2
0610105	Card, Relay (Figure 11-4-6)	1	1	1
3990010	Diode - 6 Amp (Figure 11-7-1)	2	2	2
<b>VARIABLE PARTS</b>				
4360277	Limit Switch (French Spec) (Figure 11-1-5, 11-4-3 and 11-4-4)	1	1	1
7012308	Coil (Proportional Drive) (Figure 11-2-4)	1	1	1
7011551	Controller (Single Voltage Charger) (Figure 11-2-6)	1	1	1
7011548	Fuse - 10 Amp (Euro Spec except UK and Australian Spec) (Figure 11-2-6)	1	1	1
7011657	Fuse - 5 Amp (UK and Australian Spec) (Figure 11-2-6 and 11-2-7)	1	1	1
4360328	Switch, Toggle (Toggle Switch Drive) (Figure 11-4-6)	1	1	1
4360314	Switch, Toggle (Toggle Switch Drive) (Figure 11-4-6)	1	1	1
4360345	Switch, Toggle (Toggle Switch Drive - 2SPD) (Figure 11-4-6)	1	1	1
4360355	Switch, Toggle (Toggle Switch Drive - 3SPD) (Figure 11-4-6)	1	1	1
1600156	PQ Controller (PQ Bang-Bang Drive) (Figure 11-4-6)	1	1	1
7003789	Switch, Steer (PQ Bang-Bang Drive)	1	1	1
7011937	Electrical Assembly (PQ Bang-Bang Drive)	1	1	1
1600160	PQ Controller (PQ Proportional Drive) (Figure 11-4-6)	1	1	1

## SECTION 10 RECOMMENDED SERVICE PARTS STOCK

CM2033/CM2046/CM2546/CM2558

The following lists will service fleets of machines (built to current production per date on the front cover) with emergency repair parts which can be installed in the field. Parts from the list should be replaced when inventory is depleted to keep service parts stock supplied. For further information, contact your JLG dealer or the JLG Industries Parts Department.

JLG PART NO.	DESCRIPTION	QTY. PER FLEET SIZE		
		1-4	5-9	10 or More
<b>VARIABLE PARTS</b>				
7003789	Switch, Steer (PQ Proportional Drive)	1	1	1
7011939	Electrical Assembly (PQ Proportional Drive)	1	1	1
7011923	Electrical Assembly (PQ Proportional Drive)	1	1	1
7003751	Potentiometer (PQ Proportional Drive)	1	1	1
1692617	Switch, Pressure (Over-Load) (French Spec) (Figure 11-5-3)	1	1	1
2900838	U.S. Standards Fastener Kit	1	1	1
7014676	U.S. Standards Tool Kit	1	1	1

# SECTION 11 ILLUSTRATED PARTS LIST

## CM2033/CM2046/CM2546/CM2558

FIGURE NO.	DESCRIPTION	PAGE NO.
<b>SECTION 11-1 — FRAME</b>		
11-1-1	Frame, Steering and Drive Installation . . . . .	11-1-2
11-1-2	Drive Motor Assemblies . . . . .	11-1-8
11-1-3	Rear Axle and Brake Installations (Prior to March 1992) . . . . .	11-1-10
11-1-4	Rear Axle and Brake Installations (March 1992 to Present) . . . . .	11-1-14
11-1-5	Frame Mounted Components Installation . . . . .	11-1-16
<b>SECTION 11-2 — GROUND COMPONENTS</b>		
11-2-1	Covers, Controls, Tank and Valves Installation . . . . .	11-2-2
11-2-2	Control Valve Assembly - Hydro-Air (Machines with Bang-Bang Drive Built Built Prior to June 1992) . . . . .	11-2-8
11-2-3	Control Valve Assembly - Hydro-Air (Machines with Bang-Bang Drive Built June 1992 to Present) . . . . .	11-2-12
11-2-4	Control Valve Assembly - Hydro Air (Machines with Proportional Drive) . . . . .	11-2-16
11-2-5	Batteries and Chargers Installation . . . . .	11-2-20
11-2-6	Battery Charger Assembly - Single Voltage . . . . .	11-2-24
11-2-7	Battery Charger Assembly - Dual Voltage . . . . .	11-2-26
<b>SECTION 11-3 — SIZZOR ARMS</b>		
11-3-1	Sizzor Arms Installation - CM2033 and CM2046 . . . . .	11-3-2
11-3-2	Sizzor Arms Installation - CM2546 and CM2558 . . . . .	11-3-6
11-3-3	Sizzor Arms Guards Installation (Prior to August 1992) . . . . .	11-3-10
11-3-4	Sizzor Arms Guards Installation (August 1992 to May 1994) . . . . .	11-3-12
11-3-5	Sizzor Arms Guards Installation (May 1994 to June 1995) . . . . .	11-3-14
11-3-6	Sizzor Arms Guards Installation (June 1995 to Present) . . . . .	11-3-16
<b>SECTION 11-4 — PLATFORM</b>		
11-4-1	Standard Handrails and Accessories Installation . . . . .	11-4-2
11-4-2	Optional Fold-Down Handrail Installations . . . . .	11-4-8
11-4-3	Optional Extendable Deck Installation with Standard Handrails . . . . .	11-4-12
11-4-4	Optional Extendable Deck Installation with Fold-Down Handrails . . . . .	11-4-14
11-4-5	Steel Platform Console Box Assembly . . . . .	11-4-18
11-4-6	Molded Platform Console Box Assembly . . . . .	11-4-22
<b>SECTION 11-5 — CYLINDERS</b>		
11-5-1	Brake Cylinder Assembly (Prior to March 1992) . . . . .	11-5-2
11-5-2	Brake Cylinder Assembly (March 1992 to Present) . . . . .	11-5-4
11-5-3	Lift Cylinder Sub-Assembly . . . . .	11-5-6
11-5-4	Steer Cylinder Assembly . . . . .	11-5-10
<b>SECTION 11-6 — HYDRAULIC</b>		
11-6-1	Hydraulic Diagram - Bang-Bang Drive . . . . .	11-6-2
11-6-2	Hydraulic Diagram - Proportional Drive . . . . .	11-6-6

## SECTION 11 ILLUSTRATED PARTS LIST CM2033/CM2046/CM2546/CM2558

FIGURE NO.	DESCRIPTION	PAGE NO.
<b>SECTION 11-7 — ELECTRICAL</b>		
11-7-1	Electrical Diagrams and Components Chart. . . . .	11-7-2
11-7-2	Electrical Diagram - Toggle Switch Drive (Euro except French Spec) . . . . .	11-7-10
11-7-3	Electrical Diagram - Toggle Switch (Australian Spec). . . . .	11-7-11
11-7-4	Electrical Diagram - Toggle Switch Drive (French Spec) . . . . .	11-7-12
11-7-5	Electrical Diagram - PQ Controller Bang-Bang Drive (Euro except French Spec) . . . . .	11-7-13
11-7-6	Electrical Diagram - PQ Controller Bang-Bang Drive . . . . .	11-7-14
11-7-7	Electrical Diagram - PQ Controller Bang-Bang Drive (French Spec) . . . . .	11-7-15
11-7-8	Electrical Diagram - PQ Controller Proportional Drive (Euro except French Spec) . . . . .	11-7-16
11-7-9	Electrical Diagram - PQ Controller Proportional Drive (Australian Spec). . . . .	11-7-17
11-7-9A	Electrical Diagram - PQ Controller Proportional Drive (French Spec) . . . . .	11-7-18
11-7-10	Electrical Diagram - Circuit Cards . . . . .	11-7-19
11-7-11	Main Electrical Connector and Tools. . . . .	11-7-20
<b>SECTION 11-8 — DECALS</b>		
11-8-1	Decal Installation . . . . .	11-8-2

**SECTION 11-1 FRAME**  
**CM2033/CM2046/CM2546/CM2558**

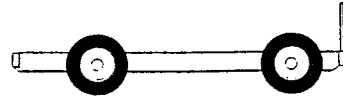

**TABLE OF CONTENTS**

FIGURE NO.	TITLE	PAGE NO.
11-1-1	Frame, Steering and Drive Installation .....	11-1-2
11-1-2	Drive Motor Assemblies .....	11-1-8
11-1-3	Rear Axle and Brake Installations (Prior to March 1992) .....	11-1-10
11-1-4	Rear Axle and Brake Installations (March 1992 to Present) .....	11-1-14
11-1-5	Frame Mounted Components Installation .....	11-1-16

**S  
E  
C  
T  
I  
O  
N  
  
1  
1  
-  
1  
  
F  
R  
A  
M  
E**

SECTION 11-1 FRAME  
 CM2033/CM2046/CM2546/CM2558

FIGURE 11-1-1. FRAME, STEERING AND DRIVE INSTALLATION.

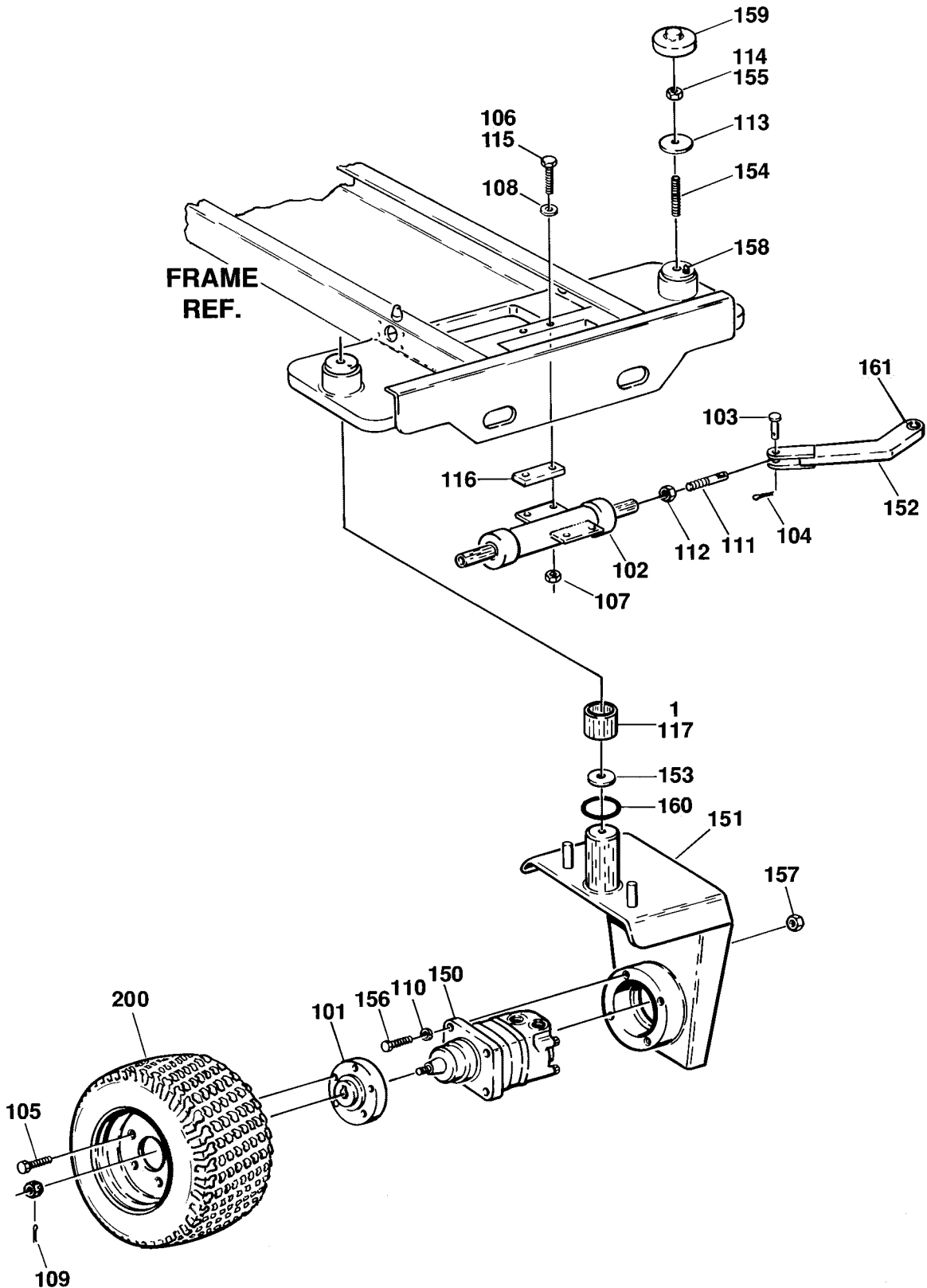
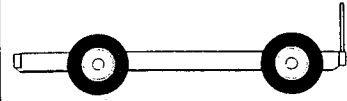

# SECTION 11-1 FRAME

## CM2033/CM2046/CM2546/CM2558



SECTION 11-1 FRAME

FIGURE & ITEM NO	PART NUMBER	DESCRIPTION	QTY.	REV.
11-1-1		<b>FRAME, STEERING AND DRIVE INSTALLATION</b>	Ref.	
		<b>FRAME WELDMENTS (PRIOR TO MARCH 1992)</b>	Ref.	
	2360323	Frame - Standard (Model CM2033)	1	
	2360342	Frame - Optional with Lifting Lugs (Model CM2033)	1	
	2360327	Frame - Standard (Models CM2046 and CM2546)	1	
	2360354	Frame - Optional with Lifting Lugs (Models CM2046 and CM2546)	1	
	2360328	Frame - Standard (Model CM2558)	1	
		All Frames Include:		
-1	0961482	Bushing, Bronze	2	
		<b>FRAME WELDMENTS (MARCH 1992 TO PRESENT)</b>	Ref.	
	2360343	Frame - Standard (Model CM2033)	1	
	2360346	Frame - Optional with Lifting Lugs (Model CM2033)	1	
	2360355	Frame - Standard (Model CM2046 and CM2546)	1	
	2360359	Frame - Optional with Lifting Lugs (Model CM2046 and CM2546)	1	
	2360356	Frame - Standard (Model CM2558)	1	
	2360362	Frame - Optional with Lifting Lug (Model CM2558)	1	
		All Frames Include:		
-1	0961615	Bushing, Bronze (Models CM2046, CM2546 and CM2558)	4	
	0961626	Bushing, Bronze (Model CM2033)	4	
		<b>STEERING AND DRIVE INSTALLATION (STANDARD PARTS)</b>	Ref.	
-101	2780165	Hub	2	
-102	1682996	Steer Cylinder Assembly- CM2033 Prior to August 1995 (See Section 11-5 for Breakdown)	1	
	1682997	Steer Cylinder Assembly - CM2046, CM2546 and CM2558 Prior to August 1995 (See Section 11-5 for Breakdown)	1	
	1683408	Steer Cylinder Assembly - All Machines August 1995 to Present (See Section 11-5 for Breakdown)	1	
-103	3430612	Pin, Clevis 3/8" (.8cm) x 1 1/2" (3.8cm)	2	
-104	3450404	Pin, Cotter 1/8" (.3cm) x 1" (2.5cm)	2	
-105	0630305	Bolt, Wheel	10	
-106	0641618	Bolt 3/8"-16NC x 2 1/4" (Front Location)	2	
-107	3311605	Locknut 3/8"-16NC	4	
-108	4711600	Flatwasher 3/8" Narrow	4	
-109	3450406	Pin, Cotter 1/8" (.3cm) x 1 1/2" (3.8 cm)	2	
-110	4761800	Lockwasher 1/2"	8	
-111	0361928	Rod, Adjusting	2	
-112	3322202	Nut, Jam 3/4"-16NF	2	
-113	4752000	Flatwasher 5/8"	2	
-114	0100011	Loctite	A/R	
-115	0641612	Bolt 3/8"-16NC x 1 1/2" (Rear Location)	2	
-116	4070769	Shim, Cylinder Mounting	1	
-117	3020010	Lubricant, "Neverseez"	A/R	

# SECTION 11-1 FRAME

## CM2033/CM2046/CM2546/CM2558



FIGURE & ITEM NO	PART NUMBER	DESCRIPTION	QTY.	REV.
11-1-1		<b>FRAME, STEERING AND DRIVE INSTALLATION (CONTINUED)</b>	Ref.	
	0251102	<b>STEERING AND DRIVE INSTALLATION - MODEL CM2033 (PRIOR TO MARCH 1992) (VARIABLE PARTS)</b>	Ref.	G
-150	3160173	Drive Motor Assembly (See Figure 11-1-2 for Breakdown)	2	
-151	4130238	Spindle Weldment	2	
-152	1360227	Clevis Weldment	2	
-153	4740375	Washer, Thrust	2	
-154	4300095	Stud 5/8"-11NC x 2 1/4"	2	
-155	3312005	Locknut 5/8"-11NC	2	
-156	0641816	Bolt 1/2"-13NC x 2"	8	
-157	3311801	Nut 1/2"-13NC	8	
-158	2160006	Fitting, Grease	2	
-159 to -161	Not Required			
	0252219	<b>STEERING AND DRIVE INSTALLATION - MODEL CM2033 (MARCH 1992 TO AUGUST 1990) (VARIABLE PARTS)</b>	Ref.	C
-150	3160173	Drive Motor Assembly (See Figure 11-1-2 for Breakdown)	2	
-151	4130269	Spindle Weldment	2	
-152	1360227	Clevis Weldment (Use 1360261 Clevis and 0961931 Bushing as Replacement)	2	
-153	4740419	Washer, Thrust	2	
-154	4300093	Stud 3/8"-16NC x 2"	2	
-155	3311605	Locknut 3/8"-16NC	2	
-156	0641816	Bolt 1/2"-13NC x 2"	8	
-157	3311801	Nut 1/2"-13NC	8	
-158	Not Required			
-159	1120417	Cap, Plastic	2	
-160	Not Required			
-161	Not Required			
	0255021	<b>STEERING AND DRIVE INSTALLATION - MODEL CM2033 (AUGUST 1994 TO PRESENT) (VARIABLE PARTS)</b>	Ref.	A
-150	3160173	Drive Motor Assembly (See Figure 11-1-2 for Breakdown)	2	
-151	4130321	Spindle Weldment	2	
-152	1360261	Clevis Weldment (Use 1360261 Clevis and 0961931 Bushing as Replacement)	2	
-153	4740419	Washer, Thrust	2	
-154	4300093	Stud 3/8"-16NC x 2"	2	
-155	3311605	Locknut 3/8"-16NC	2	
-156	0641816	Bolt 1/2"-13NC x 2"	8	
-157	3311801	Nut 1/2"-13NC	8	
-158	2160006	Fitting, Grease	2	
-159	1120417	Cap, Plastic	2	
-160	3780166	O-Ring	2	
-161	0961931	Bushing, Fiberglass	2	



# SECTION 11-1 FRAME

## CM2033/CM2046/CM2546/CM2558



# SECTION 11-1 FRAME

FIGURE & ITEM NO	PART NUMBER	DESCRIPTION	QTY.	REV.
11-1-1		<b>FRAME, STEERING AND DRIVE INSTALLATION (CONTINUED)</b>	Ref.	
	0251383	<b>STEERING AND DRIVE INSTALALLATION - MODEL CM2046 (PRIOR TO MARCH 1992) (VARIABLE PARTS)</b>	Ref.	G
-150	3160173	Drive Motor Assembly (See Figure 11-1-2 for Breakdown)	2	
-151	4130241	Spindle Weldment	2	
-152	1360229	Clevis Weldment	2	
-153	4740375	Washer, Thrust	2	
-154	4300095	Stud 5/8"-11NC x 2 1/4"	2	
-155	3312005	Locknut 5/8"-11NC	2	
-156	0641814	Bolt 1/2"-13NC x 1 3/4"	8	
-157	Not Required			
-158	2160006	Fitting, Grease	2	
-159 to -161	Not Required			
	0252701	<b>STEERING AND DRIVE INSTALLATION - MODEL CM2046 (MARCH 1992 TO AUGUST 1994) (VARIABLE PARTS)</b>	Ref.	C
-150	3160173	Drive Motor Assembly (See Figure 11-1-2 for Breakdown)	2	
-151	4130285	Spindle Weldment	2	
-152	1360229	Clevis Weldment (Use 1360262 Clevis and 0961931 Bushing as Replacement)	2	
-153	4740418	Washer, Thrust	2	
-154	4300095	Stud 5/8"-11NC x 2 1/4"	2	
-155	3312005	Locknut 5/8"-11NC	2	
-156	0641814	Bolt 1/2"-13NC x 1 3/4"	8	
-157	Not Required			
-158	Not Required			
-159	1120418	Cap, Plastic	2	
-160	3760379	O-Ring	2	
-161	0961931	Bushing, Fiberglide	2	
	0255022	<b>STEERING AND DRIVE INSTALLATION - MODEL CM2046 (AUGUST 1994 TO PRESENT) (VARIABLE PARTS)</b>	Ref.	B
-150	3160173	Drive Motor Assembly (See Figure 11-1-2 for Breakdown)	2	
-151	4130323	Spindle Weldment	2	
-152	1360262	Clevis Weldment	2	
-153	4740418	Washer, Thrust	2	
-154	4300095	Stud 5/8"-11NC x 2 1/4"	2	
-155	3312005	Locknut 5/8"-11NC	2	
-156	0641814	Bolt 1/2"-13NC x 1 3/4"	8	
-157	Not Required			
-158	2160006	Fitting, Grease	2	
-159	1120418	Cap, Plastic	2	
-160	3760379	O-Ring	2	
-161	0961931	Bushing, Fiberglide	2	

**SECTION 11-1 FRAME**

**SECTION 11-1 FRAME  
CM2033/CM2046/CM2546/CM2558**

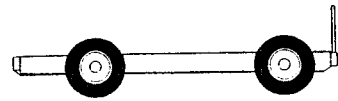

FIGURE & ITEM NO	PART NUMBER	DESCRIPTION	QTY.	REV.
11-1-1		<b>FRAME, STEERING AND DRIVE INSTALLATION (CONTINUED)</b>	Ref.	
	0251384	<b>STEERING AND DRIVE INSTALLATION - MODEL CM2046 (PRIOR TO MARCH 1992) (VARIABLE PARTS)</b>	Ref.	F
—150	3160155	Drive Motor Assembly (See Figure 11-1-2 for Breakdown)	2	
—151	4130241	Spindle Weldment	2	
—152	1360229	Clevis Weldment	2	
—153	4740375	Washer, Thrust	2	
—154	4300095	Stud 5/8"-11NC x 2 1/4"	2	
—155	3312005	Locknut 5/8" - 11NC	2	
—156	0641814	Bolt 1/2"-13NC x 1 3/4"	8	
—157	Not Required			
—158	2160006	Fitting, Grease	2	
-159 to -161	Not Required			
	0253094	<b>STEERING AND DRIVE INSTALLATION - MODEL CM2546 (MARCH 1992 TO AUGUST 1994) (VARIABLE PARTS)</b>	Ref.	B
—150	3160155	Drive Motor Assembly (See Figure 11-1-2 for Breakdown)	2	
—151	4130285	Spindle Weldment	2	
—152	1360229	Clevis Weldment (Use 1360262 Clevis and 0961931 Bushing as Replacement)	2	
—153	4740418	Washer, Thrust	2	
—154	4300095	Stud 5/8"-11NC x 2 1/4"	2	
—155	3312005	Locknut 5/8"-11NC	2	
—156	0641814	Bolt 1/2"-13NC x 1 3/4"	8	
—157	Not Required			
—158	Not Required			
—159	1120418	Cap, Plastic	2	
—160	Not Required			
—161	Not Required			
	0255023	<b>STEERING AND DRIVE INSTALLATION - MODEL CM2546 (AUGUST 1994) TO PRESENT) (VARIABLE PARTS)</b>	Ref.	C
—150	3160155	Drive Motor Assembly (See Figure 11-1-2 for Breakdown)	2	
—151	4130323	Spindle Weldment	2	
—152	1360262	Clevis Weldment (Use 1360262 Clevis and 0961931 Bushing as Replacement)	2	
—153	4740418	Washer, Thrust	2	
—154	4300095	Stud 5/8"-11NC x 2 1/4"	2	
—155	3312005	Locknut 5/8"-11NC	2	
—156	0641814	Bolt 1/2"-13NC x 1 3/4"	8	
—157	Not Required			
—158	2160006	Fitting, Grease	2	
—159	1120418	Cap, Plastic	2	
—160	3760379	O-Ring	2	
—161	0961931	Bushing, Fiberglass	2	

# SECTION 11-1 FRAME

## CM2033/CM2046/CM2546/CM2558



**SECTION 11-1 FRAME**

FIGURE & ITEM NO	PART NUMBER	DESCRIPTION	QTY.	REV.
11-1-1		<b>FRAME, STEERING AND DRIVE INSTALLATION (CONTINUED)</b>	Ref.	
	0251389	<b>STEERING AND DRIVE INSTALLATION - MODEL CM2558 (PRIOR TO MARCH 1992) (VARIABLE PARTS)</b>	Ref.	G
—150	3160155	Drive Motor Assembly (See Figure 11-1-2 for Breakdown)	2	
—151	4130242	Spindle Weldment	2	
—152	1360230	Clevis Weldment	2	
—153	4740375	Washer, Thrust	2	
—154	4300095	Stud 5/8"-11NC x 2 1/4"	2	
—155	3312005	Locknut 5/8"-11NC	2	
—156	0641814	Bolt 1/2"-13NC x 1 3/4"	8	
—157	Not Required			
—158	2160006	Fitting, Grease	1	
-159 to -161	Not Required			
	0252702	<b>STEERING AND DRIVE INSTALLATION - MODEL CM2558 (MARCH 1992 TO AUGUST 1994) (VARIABLE PARTS)</b>	Ref.	C
—150	3160155	Drive Motor Assembly (See Figure 11-1-2 for Breakdown)	2	
—151	4130284	Spindle Weldment	2	
—152	1360230	Clevis Weldment (Use 1360263 Clevis and 0961931 Bushing as Replacement)	2	
—153	4740418	Washer, Thrust	2	
—154	4300095	Stud 5/8"-11NC x 2 1/4"	2	
—155	3312005	Locknut 5/8"-11NC	2	
—156	0641814	Bolt 1/2"-13NC x 1 3/4"	8	
—157	Not Used			
—158	Not Used			
—159	1120418	Cap, Plastic	2	
—160	Not Required			
—161	Not Required			
	0255024	<b>STEERING AND DRIVE INSTALLATION - MODEL CM2558 (AUGUST 1994 TO PRESENT) (VARIABLE PARTS)</b>	Ref.	B
—150	3160155	Drive Motor Assembly (See Figure 11-1-2 for Breakdown)	2	
—151	4130322	Spindle Weldment	2	
—152	1360263	Clevis Weldment (Use 1360263 Clevis and 0961931 Bushing as Replacement)	2	
—153	4740418	Washer, Thrust	2	
—154	4300095	Stud 5/8"-11NC x 2 1/4"	2	
—155	3312005	Locknut 5/8"-11NC	2	
—156	0641814	Bolt 1/2"-13NC x 1 3/4"	8	
—157	Not Required			
—158	2160006	Fitting, Grease	2	
—159	1120418	Cap, Plastic	2	
—160	3760379	O-Ring	2	
—161	0961931	Bushing, Fiberglass	2	
		<b>TIRE ASSEMBLY OPTIONS</b>	Ref.	
—200	4520128	Tire - Solid (Standard)	4	
	4520116	Tire - Non-Marking (Optional)	4	
	4520115	Tire - Foam-Filled (Optional)	4	

SECTION 11-1 FRAME  
 CM2033/CM2046/CM2546/CM2558

FIGURE 11-1-2. DRIVE MOTOR ASSEMBLIES.

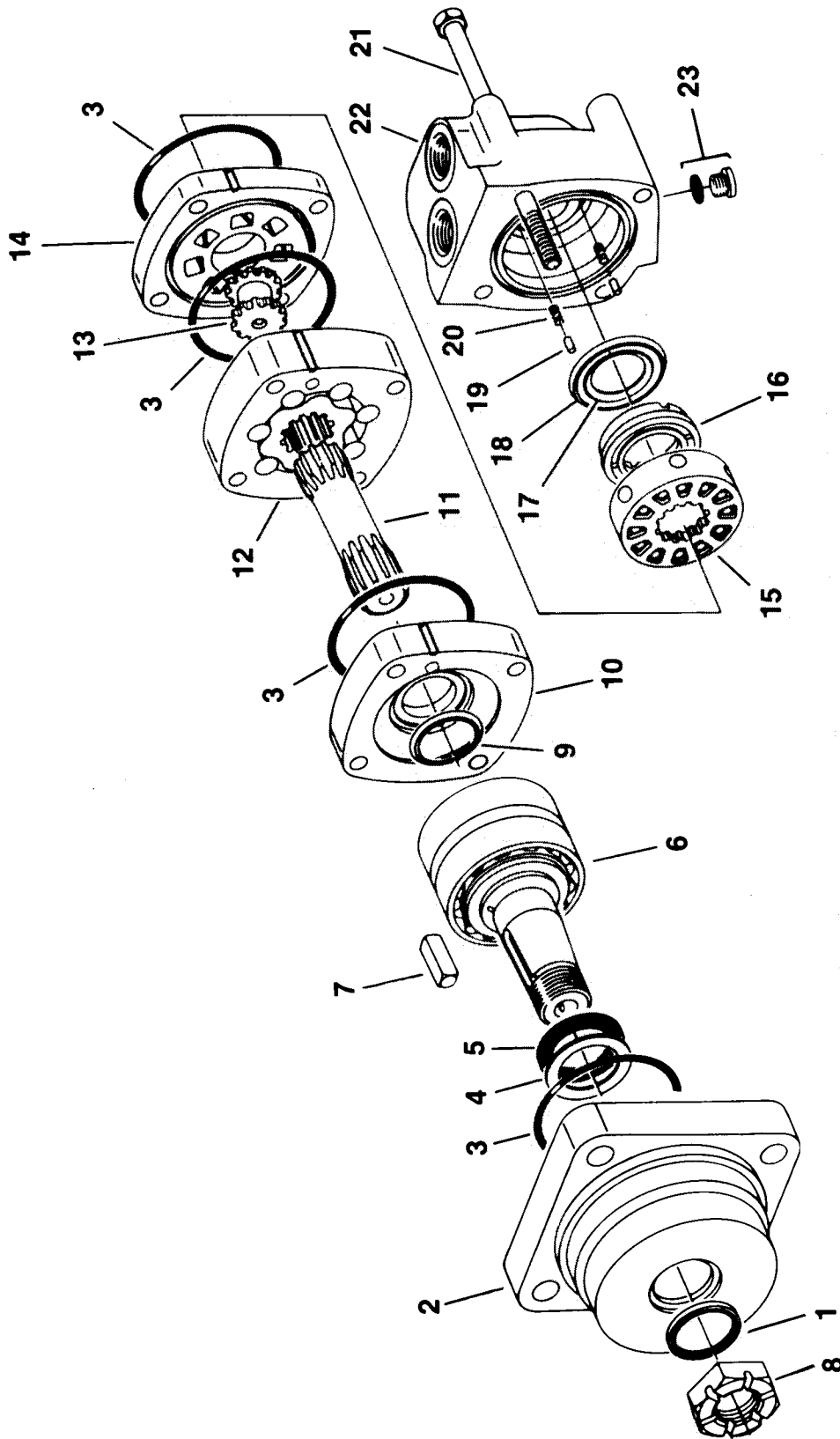
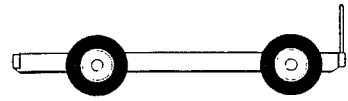

**SECTION 11-1 FRAME  
CM2033/CM2046/CM2546/CM2558**



**SECTION 11-1 FRAME**

FIGURE & ITEM NO	PART NUMBER	DESCRIPTION	QTY.	REV.
11—1—2		<b>DRIVE MOTOR ASSEMBLIES</b>	Ref.	
		<b>DRIVE MOTOR ASSEMBLIES (STANDARD PARTS)</b>	Ref.	
—1	Kit	Seal, Dust	1	
—2	7009931	Housing, Bearing	1	
—3	Kit	Seal	4	
—4	Kit	Ring, Back-up	1	
—5	Kit	Seal, Shaft	1	
—6	7009932	Shaft and Bearing	1	
—7	7009933	Key	1	
—8	7009934	Nut, Castle	1	
—9	Kit	Seal, Shaft Face	1	
—10	7009982	Plate, Wear	1	
—11	Not Used			
—12	Not Used			
—13	7009905	Drive, Valve	1	
—14	7009983	Plate, Valve	1	
—15	7009927	Valve	1	
—16	7009909	Ring, Balance	1	
—17	Kit	Seal, Face - Inner	1	
—18	Kit	Seal, Face - Outer	1	
—19	7009912	Pin	2	
—20	7009913	Spring	2	
—21	7009929	Bolt	4	
—22	7009930	Housing, Valve	1	
—23	7002157	Plug Assembly	1	
	3160155	<b>DRIVE MOTOR ASSEMBLIES - MODELS CM2546 - ALL AND CM2558 - ALL. ALSO, MODEL CM2046 - BUILT PRIOR TO MARCH 1992 (VARIABLE PARTS)</b>	Ref.	
—51	7009922	Drive	1	
—52	7009925	Geroler	1	
	3160173	<b>DRIVE MOTOR ASSEMBLIES - MODELS CM2033 - ALL AND CM2046 - BUILT MARCH 1992 TO PRESENT (VARIABLE PARTS)</b>	Ref.	
—51	7009979	Drive	1	
—52	7009980	Geroler	1	
	2900699	----- Seal Kit (Includes Items 1,3,4,5,9,17 and 18)	1	

**SECTION 11-1 FRAME**  
**CM2033/CM2046/CM2546/CM2558**

**FIGURE 11-1-3. REAR AXLE AND BRAKE INSTALLATIONS**  
 (PRIOR TO MARCH 1992).

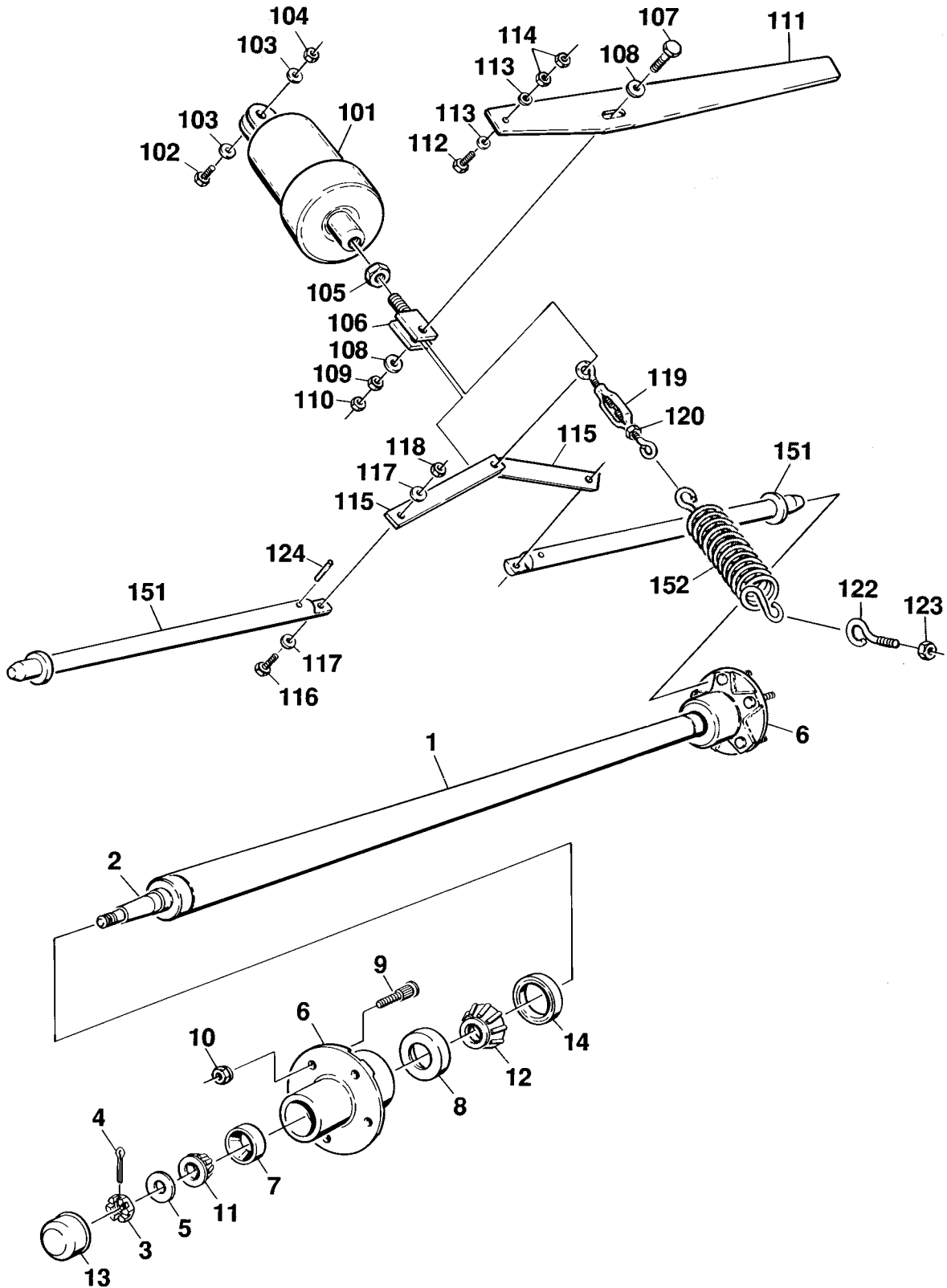
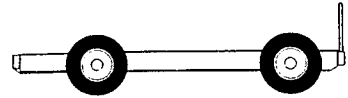

# SECTION 11-1 FRAME

## CM2033/CM2046/CM2546/CM2558



**SECTION 11-1 FRAME**

FIGURE & ITEM NO	PART NUMBER	DESCRIPTION	QTY.	REV.
11-1-3		<b>REAR AXLE AND BRAKE INSTALLATIONS (PRIOR TO MARCH 1992)</b>	Ref.	
	0280120	<b>AXLE ASSEMBLY (CM2033)</b>	Ref.	A
	0280121	<b>AXLE ASSEMBLY (CM2046/CM2546)</b>	Ref.	A
	0280122	<b>AXLE ASSEMBLY (CM2558)</b>	Ref.	A
-1	Not Serviced	Tube, Axle	1	
-2	Not Serviced	Spindle	2	
-3	7010641	Nut, Spindle	2	
-4	7010642	Pin, Cotter	2	
-5	7010643	Washer	2	
-6	7010644	Hub Assembly	2	
-7	Kit	Cup, Bearing (Outer) (1 Per Hub)	2	
-8	Kit	Cup, Bearing (Inner) (1 Per Hub)	2	
-9	7012613	Stud, Wheel 1/2"-20NF	10	
-10	7010645	Lugnut 1/2"-20NF	10	
-11	Kit	Cone, Bearing (Outer)	2	
-12	Kit	Cone, Bearing (Inner)	2	
-13	7010648	Cap, Dust	2	
-14	Kit	Seal, Hub	2	
	2900778	Bearing Kit (Includes Qty. 1 of Items 7,8,11,12 and 14)	2	
		<b>BRAKE INSTALLATIONS (STANDARD PARTS)</b>	Ref.	
-101	1682445	Brake Cylinder Assembly (See Section 11-5 for Breakdown)	1	
-102	0641620	Bolt 3/8"-16NC x 2 1/2"	1	
-103	4751600	Flatwasher 3/8"	2	
-104	3311605	Locknut 3/8"-16NC	1	
-105	3322202	Nut, Jam 3/4"-16NF	1	
-106	1360231	Clevis	1	
-107	0641624	Bolt 3/8"-16NC x 3"	1	
-108	4751600	Flatwasher 3/8"	4	
-109	3311601	Nut 3/8"-16NC	1	
-110	3311602	Nut, Jam 3/8"-16NC	1	
-111	3534818	Lever, Release	1	
-112	0641614	Bolt 3/8"-16NC x 1 3/4"	1	
-113	4751600	Flatwasher 3/8"	2	
-114	3311601	Nut 3/8"-16NC	2	
-115	3010099	Link, Brake	2	
-116	0641612	Bolt 3/8"-16NC x 1 1/2"	1	
-117	4751600	Flatwasher 3/8"	2	
-118	3311605	Locknut 3/8"-16NC	1	
-119	4600004	Turnbuckle	1	
-120	3311401	Nut 1/4"-20NC	1	
-121	Not Used			
-122	0630440	Eyebolt (Includes Nut Item 123)	1	
-123	3311401	Nut 1/4"-20NC	1	
-124	3440824	Rollpin	A/R	





**SECTION 11-1 FRAME  
CM2033/CM2046/CM2546/CM2558**

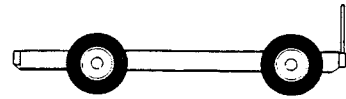

**SECTION 11 - 1 FRAME**

FIGURE & ITEM NO	PART NUMBER	DESCRIPTION	QTY.	REV.
11-1-3		<b>REAR AXLE AND BRAKE INSTALLATIONS (PRIOR TO MARCH 1992) (CONTINUED)</b>	Ref.	
	0251118	<b>BRAKE INSTALLATION - MODEL CM2033 (MACHINES BUILT PRIOR TO DECEMBER 1991) (VARIABLE PARTS)</b>	Ref.	E
-151	3841079	Rod, Brake	2	
-152	4160096	Spring	1	
	0252519	<b>BRAKE INSTALLATION - MODELS CM2033 (MACHINES BUILT DECEMBER 1991 TO MARCH 1992 (VARIABLE PARTS)</b>	Ref.	-
-151	3841079	Rod, Brake	2	
-152	0252518	Spring Assembly (Includes Items 119, 120, 122, 123 and Spring)	1	
	4160109	Spring	1	
	0251380	<b>BRAKE INSTALLATION - MODELS CM2046 AND CM2546 (MACHINES BUILT PRIOR TO DECEMBER 1991) (VARIABLE PARTS)</b>	Ref.	E
-151	4843785	Rod, Brake	2	
-152	4160096	Spring	1	
	0252521	<b>BRAKE INSTALLATION - MODELS CM2046 AND CM2558 (MACHINES BUILT DECEMBER 1991 TO MARCH 1992) (VARIABLE PARTS)</b>	Ref.	-
-151	4843785	Rod, Brake	2	
-152	0252518	Spring Assembly (Includes items 119, 120, 122, 123 and Spring)	1	
	4160109	Spring	1	
	0251381	<b>BRAKE INSTALLATION - MODEL CM2558 (MACHINES BUILT PRIOR TO DECEMBER 1991) (VARIABLE PARTS)</b>	Ref.	E
-151	4843786	Rod, Brake	2	
-152	4160096	Spring	1	
	0252521	<b>BRAKE INSTALLATION - MODEL CM2558 (MACHINES BUILT DECEMBER 1991 TO MARCH 1992) (VARIABLE PARTS)</b>	Ref.	-
-151	4843786	Rod, Brake	2	
-152	0252518	Spring Assembly (Includes Items 119, 120, 122, 123 and Spring)	1	
	4160109	Spring	1	

**SECTION 11-1 FRAME**  
**CM2033/CM2046/CM2546/CM2558**

**FIGURE 11-1-4. REAR AXLE AND BRAKE INSTALLATIONS**  
**(MARCH 1992 TO PRESENT).**

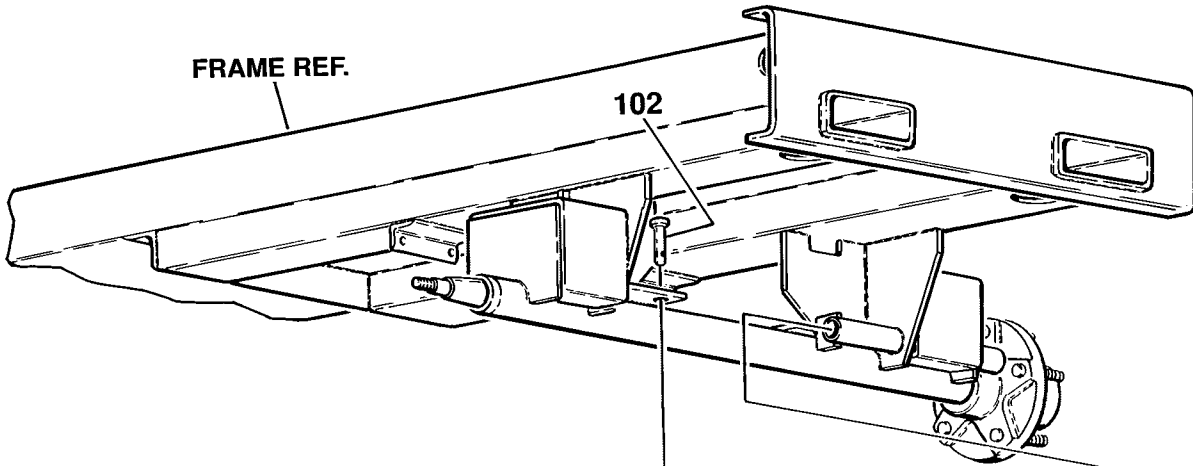
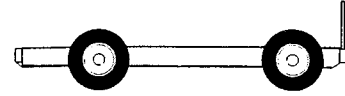

**NOTE:**  
 CYLINDER COMPONENTS  
 TYPICAL BOTH SIDES.

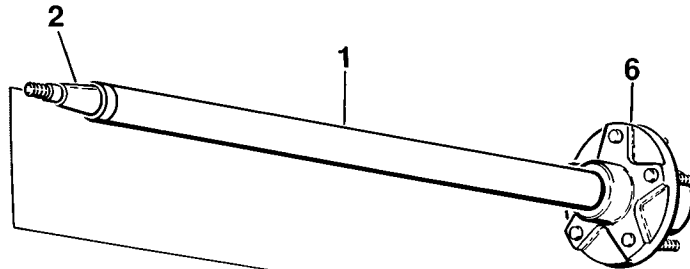
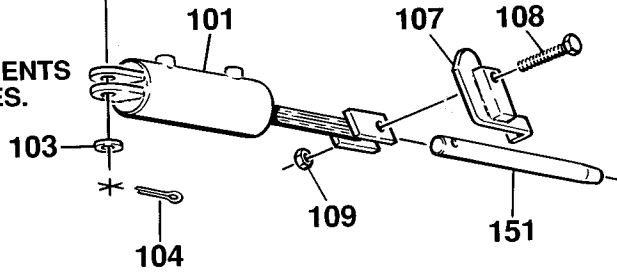

**NOTE:**  
 AXLE ASSEMBLY SHOWN  
 HERE FOR CLARITY.

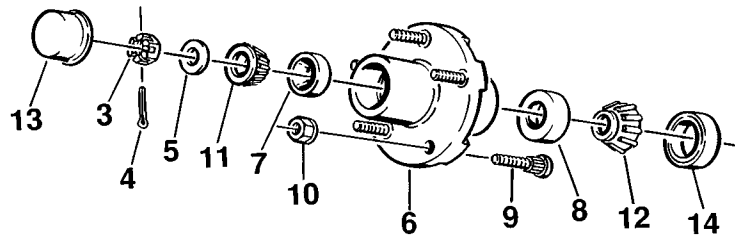

# SECTION 11-1 FRAME

## CM2033/CM2046/CM2546/CM2558

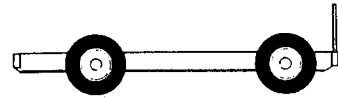

**SECTION 11-1 FRAME**

FIGURE & ITEM NO	PART NUMBER	DESCRIPTION	QTY.	REV.
11—1—4		<b>REAR AXLE AND BRAKE INSTALLATIONS (MARCH 1992 TO PRESENT)</b>	Ref.	
	0280120	<b>AXLE ASSEMBLY (CM2033)</b>	Ref.	A
	0280121	<b>AXLE ASSEMBLY (CM2046/CM2546)</b>	Ref.	A
	0280122	<b>AXLE ASSEMBLY (CM2558)</b>	Ref.	A
—1	Not Serviced	Tube, Axle	1	
—2	Not Serviced	Spindle	2	
—3	7010641	Nut, Spindle	2	
—4	7010642	Pin, Cotter	2	
—5	7010643	Washer	2	
—6	7010644	Hub Assembly	2	
—7	Kit	Cup, Bearing (Outer) (1 Per Hub)	2	
—8	Kit	Cup, Bearing (Inner) (1 Per Hub)	2	
—9	7012613	Stud, Wheel 1/2"-20NF	10	
—10	7010645	Lugnut 1/2"-20NF	10	
—11	Kit	Cone, Bearing (Outer)	2	
—12	Kit	Cone, Bearing (Inner)	2	
—13	7010648	Cap, Dust	2	
—14	Kit	Seal, Hub	2	
	2900778	Bearing Kit (Includes Qty. 1 of Items 7,8,11,12 and 14)	2	
		<b>BRAKE INSTALLATIONS (STANDARD PARTS)</b>	Ref.	
—101	1683098	Brake Cylinder Assembly (See Section 11-5 for Breakdown)	2	
—102	3430616	Pin, Clevis	2	
—103	4711600	Flatwasher 3/8" Narrow	2	
—104	3450304	Pin, Cotter 3/32" (.2cm) x 1" (2.5cm)	2	
—105	Not Used			
—106	Not Used			
—107	4844188	Cam Weldment	2	
—108	0641624	Bolt 3/8"-16NC x 3"	2	
—109	3311605	Locknut 3/8"-16NC	2	
	0252111	<b>BRAKE INSTALLATION - MODEL CM2033 (VARIABLE PARTS)</b>	Ref.	C
—151	3841129	Rod, Brake	2	
	0252700	<b>BRAKE INSTALLATION - MODELS CM2046 AND CM2546 (VARIABLE PARTS)</b>	Ref.	B
—161	3841169	Rod, Brake	2	
	0252700	<b>BRAKE INSTALLATION - MODEL CM2558 (VARIABLE PARTS)</b>	Ref.	B
—161	3841170	Rod, Brake	2	
	0255980	<b>BRAKE RELEASE VALVE INSTALLATION (AUSTRALIAN SPEC AFTER OCTOBER 1995) (NOT SHOWN)</b>	Ref.	—
	1702728	Decal (Located on Left Side Frame at Rear Wheel)	1	
	4640128	Valve (Located in Hydraulic Brake Line)	1	

SECTION 11-1 FRAME  
CM2033/CM2046/CM2546/CM2558

FIGURE 11-1-5. FRAME MOUNTED COMPONENTS INSTALLATION.

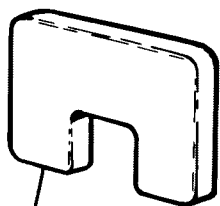

NOTE:  
COUNTERWEIGHT SHOWN  
HERE FOR CLARITY.

LOCATED BOTH SIDES  
REAR AXLE.

101

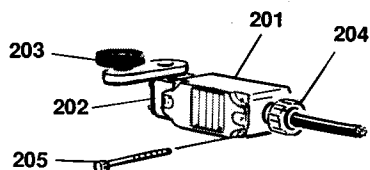
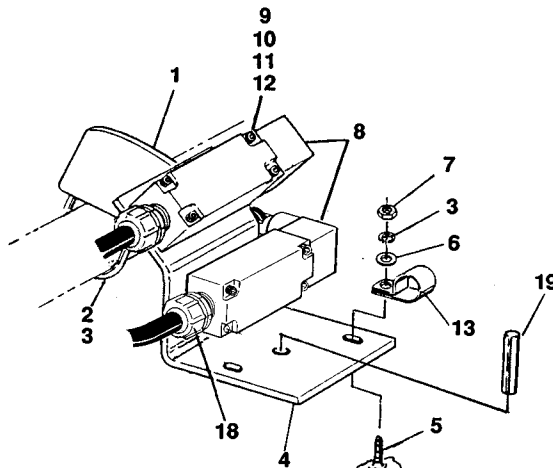

551  
502  
503  
504  
505

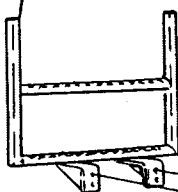

701

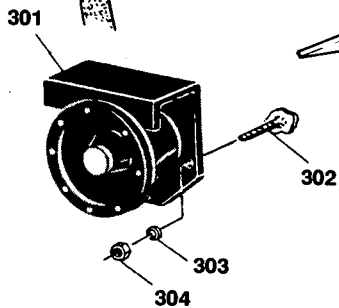

ITEM 102 NOT SHOWN

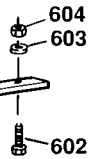
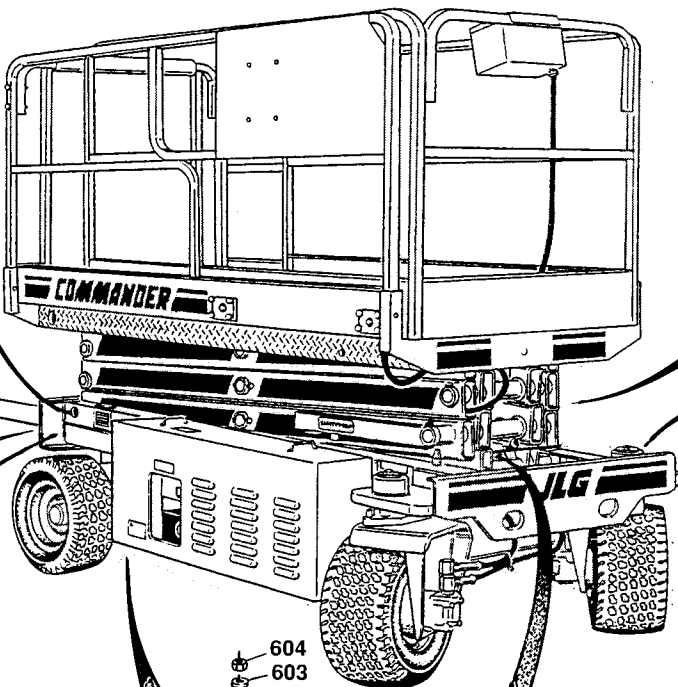

15

16

17

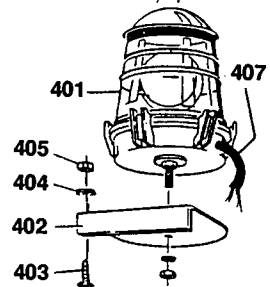
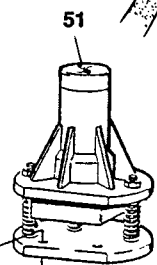

# SECTION 11-1 FRAME

## CM2033/CM2046/CM2546/CM2558

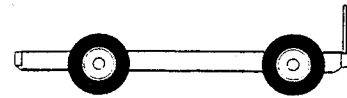

SECTION 11-1 FRAME

FIGURE & ITEM NO	PART NUMBER	DESCRIPTION	QTY.	REV.
11-1-5		<b>FRAME MOUNTED COMPONENTS INSTALLATION</b>	Ref.	
		<b>LIMIT SWITCH INSTALLATION (STANDARD PARTS)</b>	Ref.	
-1	4843962	Cam, Switch	1	
-2	1320021	Clamp	1	
-3	4761500	Lockwasher 5/16"	4	
-4	3535056	Plate, Switch Mounting	1	
-5	4300038	Stud (Welded on Part)	2	
-6	4751800	Flatwasher 5/16"	2	
-7	3311501	Nut 5/16"-18NC	2	
-8	4360300	Switch, Limit	A/R	
		Euro Spec Except Italian Spec	2	
		Italian Spec	1	
-9	3930832	Screw, Machine #8-32 x 2"	A/R	
-10	4750800	Flatwasher #8	A/R	
-11	4760800	Lockwasher #8	A/R	
-12	3310801	Nut #8-32NC	A/R	
-13	1320061	Clamp	2	
-14	Not Used			
-15	0641407	Bolt 1/4"-20NC x 7/8"	2	
-16	4761400	Lockwasher 1/4"	2	
-17	3311401	Nut 1/4"-20NC	2	
-18	4460049	Connector, Strain Relief	A/R	
		Euro Spec Except Italian Spec	2	
		Italian Spec	1	
-19	3440616	Rollpin 3/16" x 1"	2	
	1281645	<b>LIMIT SWITCHES INSTALLATION - MACHINES BUILT PRIOR TO AUGUST 1992 (VARIABLE PARTS)</b>	Ref.	E
	0251723	CM2033/2046 (5 Meter)	Ref.	C
	0251723	CM2546/2558 (6.4 Meter)	Ref.	C
	0252387	CM2033/2046/2558 (Italian Spec)	Ref.	—
-51	4360296	Sensor, Level - 3°	1	
	1281950	<b>LIMIT SWITCHES INSTALLATION MACHINES BUILT AUGUST 1992 TO PRESENT (VARIABLE PARTS)</b>	Ref.	D
	0253490	CM2033/2046 (5 Meter)	Ref.	—
	0253490	CM2546/2558 (6.4 Meter)	Ref.	—
	0253492	CM2033/2046/2546/2558 (Italian Spec)	Ref.	A
-51	4360349	Sensor, Level - 2.5°	1	
	7012608	Fuse - 1.5 Amp (Black Sensor Only) (Orange and Blue Sensors are Self-Resetting - No Fuse Required)		
	0252452	<b>OUTDOOR PACKAGE INSTALLATION - STANDARD ON MODELS CM2046 AND CM2558</b>	Ref.	A
-101	4821120	Counterweight	2	
-102	3252154	Nameplate - Capacity	1	

SECTION 11-1 FRAME

**SECTION 11-1 FRAME**  
**CM2033/CM2046/CM2546/CM2558**

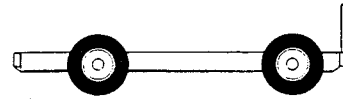
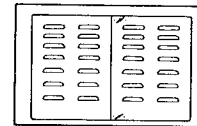

FIGURE & ITEM NO	PART NUMBER	DESCRIPTION	QTY.	REV.
11-1-5		<b>FRAME MOUNTED COMPONENTS INSTALLATIO (CONTINUED)</b>	Ref.	
	0252529	<b>LIMIT SWITCH INSTALLATION (FRENCH SPEC ONLY - OVERLOAD BY-PASS)</b>	Ref.	B
-201	4360277	Switch, Limit	1	
-202	4360236	Head, Switch Actuator	1	
-203	4360237	Roller and Arm	1	
-204	4460052	Connector, Strain Relief	1	
-205	3900168	Screw, Special	2	
	0251762	<b>DESCENT ALARM INSTALLATION (OPTIONAL)</b>	Ref.	B
	0251761	<b>MOTION ALARM INSTALLATION (TOGGLE SWITCH AND PQ BANG-BANG DRIVE (OPTIONAL)</b>	Ref.	B
	0254268	<b>MOTION ALARM INSTALLATION (PQ PROPORTIONAL DRIVE) (OPTIONAL)</b>	Ref.	—
	0251760	<b>TRAVEL ALARM INSTALLATION (TOGGLE SWITCH AND PQ BANG-BANG DRIVE) (OPTIONAL)</b>	Ref.	B
	0254267	<b>TRAVEL ALARM INSTALLATION (PQ PROPORTIONAL DRIVE ) (OPTIONAL)</b>	Ref.	—
-301		Alarm Options		
	0140025	Alarm (No Longer Available - Use 0140033)	1	
	0140033	Alarm (Used August 1993 to Present)		
-302	4300038	Stud (Welded on Part)	2	
-303	4761500	Lockwasher 5/16"	2	
-304	3311501	Nut 5/16"-18NC	2	
	0252274	<b>BEACON LIGHT INSTALLATION</b>	Ref.	A
-401	2920087	Light, Beacon	1	
-402	0901546	Bracket, Mounted	1	
-403	4300041	Stud (Welded on Part)	2	
-404	4761400	Lockwasher 1/4"	2	
-405	3311401	Nut 1/4"-20NC	2	
-406	Not Used			
-407	1060341	Cable, Electrical - 16/2	6 ft./1.8m	
		<b>LADDER INSTALLATION (STANDARD PARTS)</b>	Ref.	
-501	Not Used			
-502	0641610	Bolt 3/8"-16NC x 1 1/4"	4	
-503	4761600	Lockwasher 3/8"	4	
-504	4751600	Flatwasher 3/8"	4	
-505	3311601	Nut 3/8"-16NC	4	
	0252853	<b>LADDER INSTALLATION (PRIOR TO APRIL 1995) (VARIABLE PARTS)</b>	Ref.	A
-551	4844049	Ladder Weldment	1	
	3520071	Plug, Cap	2	
	0255704	<b>LADDER INSTALLATION (APRIL 1995 TO PRESENT) (VARIABLE PARTS)</b>	Ref.	—
-551	4844564	Ladder Weldment	1	
	3520071	Plug, Cap	2	

**SECTION 11-2 GROUND COMPONENTS  
CM2033/CM2046/CM2546/CM2558**



**TABLE OF CONTENTS**

FIGURE NO.	DESCRIPTION	PAGE NO.
11-2-1	Covers, Controls, Tank and Valves Installation . . . . .	11-2-2
11-2-2	Control Valve Assembly - Hydro-Air (Machines with Bang-Bang Drive Built Prior to June 1992) . . . . .	11-2-8
11-2-3	Control Valve Assembly - Hydro-Air (Machines with Bang-Bang Drive Built June 1992 to Present) . . . . .	11-2-12
11-2-4	Control Valve Assembly - Hydro Air (Machines With Proportional Drive) . . . . .	11-2-16
11-2-5	Batteries and Chargers Installation . . . . .	11-2-20
11-2-6	Battery Charger Assembly - Single Voltage . . . . .	11-2-24
11-2-7	Battery Charger Assembly - Dual Voltage . . . . .	11-2-26

**SECTION 11-2 GROUND COMPONENTS**

S-H-Z-M-Z-O-P-M-O-C-D-Z-C-O-R-G-N-11-Z-O-H-O-M-S

# SECTION 11-2 GROUND COMPONENTS CM2033/CM2046/CM2546/CM2558

FIGURE 11-2-1. COVERS, CONTROLS, TANK AND VALVES INSTALLATION.

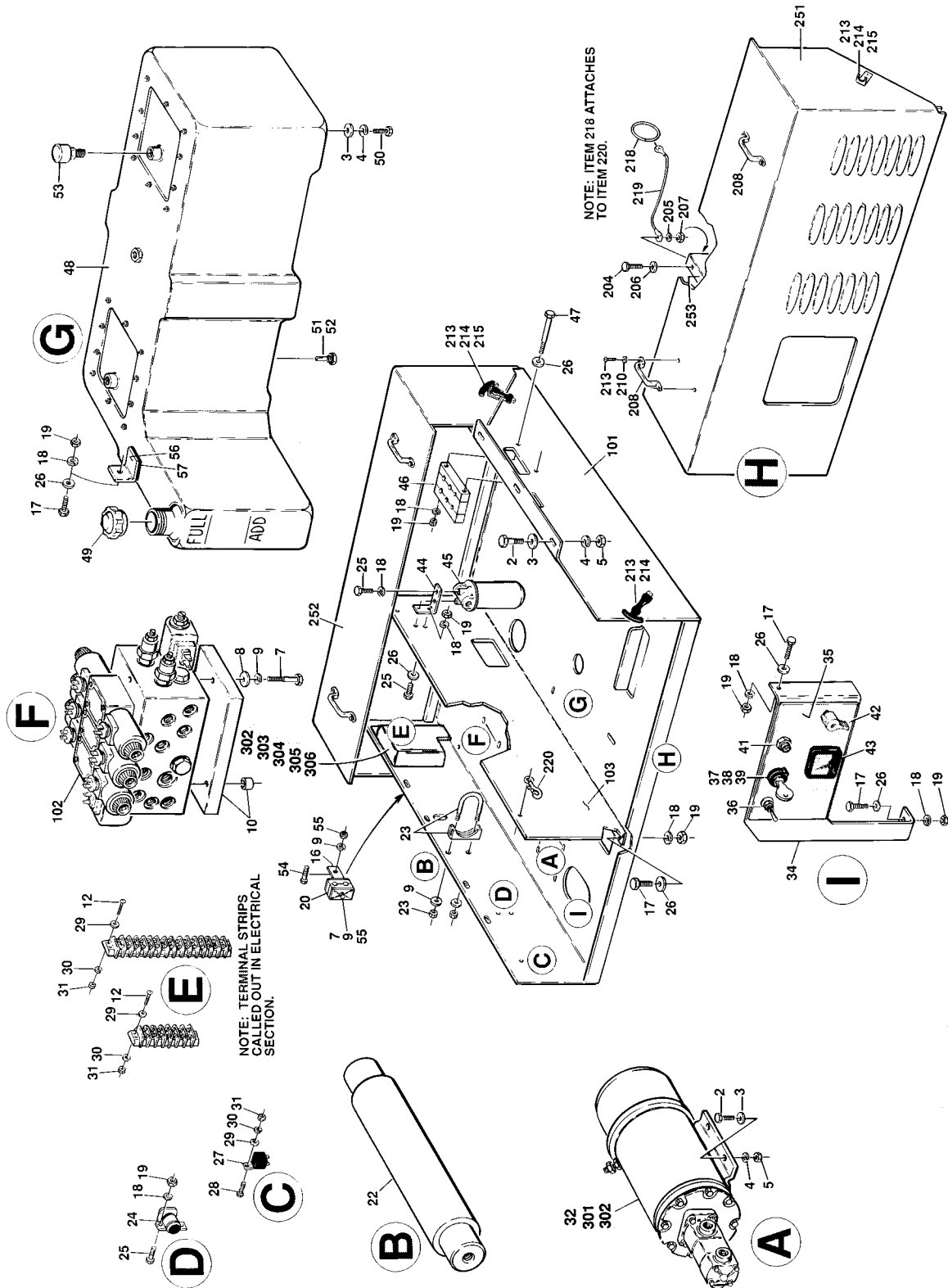
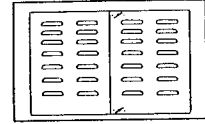

NOTE: TERMINAL STRIPS CALLED OUT IN ELECTRICAL SECTION.

NOTE: ITEM 218 ATTACHES TO ITEM 220.



# SECTION 11-2 GROUND COMPONENTS CM2033/CM2046/CM2546/CM2558

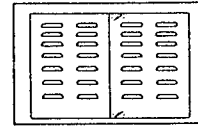

SECTION 11 - 2 GROUND COMPONENTS

FIGURE & ITEM NO	PART NUMBER	DESCRIPTION	QTY.	REV.
11-2-1		<b>COVERS, CONTROLS, TANK AND VALVES INSTALLATION</b>	Ref.	
		<b>GROUND CONTROLS, TANKS AND VALVES INSTALLATION</b>	Ref.	
-1	Not Used			
-2	0641609	Bolt 3/8"-16NC x 1 1/8"	A/R	
-3	4751600	Flatwasher 3/8"	A/R	
-4	4761600	Lockwasher 3/8"	A/R	
-5	3311601	Nut 3/8"-16NC	A/R	
-6	Not Used			
-7	0641516	Bolt 5/16"-18NC x 2"	4	
-8	4751500	Flatwasher 5/16"	4	
-9	4761500	Lockwasher 5/16"	8	
-10		Spacer Options:	A/R	
	3534699	Plate (Machines Built Prior to September 1991)	1	
	0961378	Bushing (Machines Built September 1991 to Present)	3	
-11	Not Used			
-12	3911016	Screw, Machine #10-24NC x 1"	2	
-13	Not Used			
-14	Not Used			
-15	Not Used			
-16	0181593	Angle, Mounting	1	
-17	0641407	Bolt 1/4"-20NC x 7/8"	5	
-18	4761400	Lockwasher 1/4"	A/R	
-19	3311401	Nut 1/4"-20NC	A/R	
-20	1320159	Clamp, Hose	1	
-21	Not Used			
-22	1682664	Cylinder, Cushion (Bang-Bang Drive Units Only)	1	
		<b>Note: Machines built prior to March 1992 require larger size clamp P/N 1320185 for installation.</b>		
	3480163	Piston	1	
	2901209	Seal Kit	1	
	2180699	Fitting, 90°	2	
	2180422	Fitting	2	
-23	1320185	Clamp, Muffler	1	
-24	3740068	Relay - 200 Amp/24VDC	1	
-25	0641406	Bolt 1/4"-20NC x 3/4"	7	
-26	4751400	Flatwasher 1/4"	A/R	
-27	3740069	Relay	1	
-28	3911012	Screw, Machine #10-24NC x 3/4"	1	
-29	4751000	Flatwasher #10	3	
-30	4761000	Lockwasher #10	3	
-31	3311001	Nut #10-24NC	3	
-32		Pump/Motor Assembly Options:		
	3600148	Barnes Pump/Prestolite Motor Assembly - Tang Drive (Machines Built Prior to June 1990)	1	
		<b>Note: When replacing complete pump/motor assembly use 3600184.</b>		
		Prestolite Motor Assembly(Purchase 7010924 as Replacement)	1	
	7012565	Brush Kit for 7004338 Motor (Brushes Only)	1	
	7004336	Barnes Pump Assembly	1	

# SECTION 11-2 GROUND COMPONENTS

## CM2033/CM2046/CM2546/CM2558

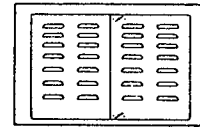

SECTION 11 - 2 GROUND COMPONENTS

FIGURE & ITEM NO	PART NUMBER	DESCRIPTION	QTY.	REV.
11-2-1		<b>COVERS, CONTROLS, TANK AND VALVES INSTALLATION (CONTINUED)</b>	Ref.	
	3600148	Barnes Pump/Ohio Motor Assembly - Tang Drive (Machines Built June 1990 to August 1991) <b>Note: When replacing complete pump/motor assembly use 3600184.</b>	1	
	7010924	Ohio Motor Assembly	1	
	7010639	Brush for 7010924 Motor	2	
	7010640	Spring for 7010924 Motor	8	
	7010952	Barnes Pump Assembly	1	
	3600184	Barnes Pump/Ohio Motor Assembly - Flex Drive (Machines Built August 1991 to Present)	1	
	7010943	Ohio Motor Assembly	1	
	7010639	Brush for 7010943 Motor	2	
	7010640	Spring for 7010943 Motor	8	
	7010951	Barnes Pump Assembly	1	
	7010944	Coupling, Flex	1	
-33	Not Used			
-34	3534561	Plate, Ground Control	1	
-35	3252091	Nameplate - Ground Control	1	
-36	4360202	Switch, Toggle	1	
-37		Key Switch Options:	1	
	4360290	Switch (Prior to January 1994) *		
	7010698	Key, Replacement (1 set)		
	4360319	Switch (January 1994 to Present)		
	7012560	Key, Replacement (1 set)		
-38	4360267	Block, Contact (Prior to January 1994)	1	
-39	4360281	Block, Contact (Prior to January 1994)	1	
-40	Not Used			
-41	4360070	Breaker, Circuit	1	
-42	4360155	Switch, Master	1	
-43	2420116	Ammeter	1	
-44	0901728	Bracket, Filter Mounting	1	
-45	2120105	Filter, Return	1	
	2120072	Element - 20 Micron (Standard)	1	
	2120148	Element - 10 Micron (Optional)	1	
-46	1320178	Clamp, Tube	1	
-47	0641432	Bolt 1/4"-20NC x 4"	2	
-48	4400324	Tank, Hydraulic (Includes Item 49)	1	
-49	1120361	Cap, Tank	1	
-50	0641608	Bolt 3/8"-16NC x 1"	2	
-51	3520076	Plug, Magnetic	1	
-52	0100020	Sealant, Pipe	A/R	
-53	1340052	Breather	1	
-54	0641508	Bolt 5/16"-18NC x 1"	2	
-55	3311501	Nut 5/16"-18NC	3	
-56	0181636	Angle, Mounting	1	
-57	4420038	Tape, Insulation	2 in./5cm	

# SECTION 11-2 GROUND COMPONENTS CM2033/CM2046/CM2546/CM2558

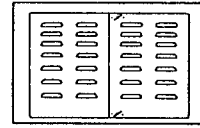
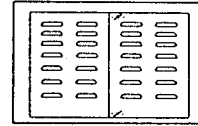

FIGURE & ITEM NO	PART NUMBER	DESCRIPTION	QTY.	REV.
11—2—1		<b>COVERS, CONTROLS, TANK AND VALVES INSTALLATION (CONTINUED)</b>	Ref.	
	0251672	<b>GROUND CONTROLS, TANK AND VALVES INSTALLATION - CM2033 WITH BANG-BANG DRIVE (VARIABLE PARTS)</b>	Ref.	J
—101	3534467	Hydraulic Tray Options: Tray, Hydraulic (Prior to January 1994)	1	
	3537285	Tray, Hydraulic (January 1994 to Present)		
—102	4640657	Control Valve Assembly - Machines built prior to June 1992 (See Figure 11-2-2 for Breakdown)	1	
	4640733	Control Valve Assembly - Machines June 1992 to Present (See Figure 11-2-3 for Breakdown)	1	
—103	3534649	Plate, Divider	1	
	0252427	<b>GROUND CONTROLS, TANK AND VALVES INSTALLATION - CM2033 WITH PROPORTIONAL DRIVE (VARIABLE PARTS)</b>	Ref.	C
—101	3534467	Hydraulic Tray Options: Tray, Hydraulic (Prior to January 1994)	1	
	3537285	Tray, Hydraulic (January 1994 to Present)		
—102	0252689	Control Valve Assembly (See Figure 11-2-4 for Breakdown)	1	
—103	3534649	Plate, Divider	1	
	0251673	<b>GROUND CONTROLS, TANK AND VALVES INSTALLATION - CM2046 WITH BANG-BANG DRIVE (VARIABLE PARTS)</b>	Ref.	K
—101	3534650	Hydraulic Tray Options: Tray, Hydraulic (Prior to January 1994)	1	
	3537284	Tray, Hydraulic (January 1994 to Present)		
—102	4640657	Control Valve Assembly - Machines built prior to June 1992 (See Figure 11-2-2 for Breakdown)	1	
	4640733	Control Valve Assembly - Machines built June 1992 to Present (See Figure 11-2-3 for Breakdown)	1	
—103	3534651	Plate, Divider	1	
	0252424	<b>GROUND CONTROLS, TANK AND VALVES INSTALLATION - CM2046 WITH PROPORTIONAL DRIVE (VARIABLE PARTS)</b>	Ref.	C
—101	3534650	Hydraulic Tray Options: Tray, Hydraulic (Prior to January 1994)	1	
	3537284	Tray, Hydraulic (January 1994 to Present)		
—102	0252689	Control Valve Assembly (See Figure 11-2-4 for Breakdown)		
—103	3534651	Plate, Divider	1	

SECTION 11 - 2 GROUND COMPONENTS

# SECTION 11-2 GROUND COMPONENTS CM2033/CM2046/CM2546/CM2558



**SECTION 11 - 2 GROUND COMPONENTS**

FIGURE & ITEM NO	PART NUMBER	DESCRIPTION	QTY.	REV.
11—2—1		<b>COVERS, CONTROLS, TANK AND VALVES INSTALLATION (CONTINUED)</b>	Ref.	
	0251674	<b>GROUND CONTROLS, TANK AND VALVES INSTALLATION CM2546 AND CM2558 WITH BANG-BANG DRIVE (VARIABLE PARTS)</b>	Ref.	J
—101	4843805	Tray, Hydraulic	1	
—102	4640657	Control Valve Assembly - Machines built prior to June 1992 (See Figure 11-2-2 for Breakdown)	1	
	4640733	Control Valve Assembly - Machines built June 1992 to Present (See Figure 11-2-3 for Breakdown)	1	
—103	3534651	Plate, Divider	1	
	0252425	<b>GROUND CONTROLS, TANK AND VALVES INSTALLATION - CM2546 AND CM2558 WITH PROPORTIONAL DRIVE (VARIABLE PARTS)</b>	Ref.	C
—101	4843805	Tray, Hydraulic	1	
—102	0252689	Control Valve Assembly (See Figure 11-2-4 for Breakdown)	1	
—103	3534651	Plate, Divider	1	
		<b>COVERS INSTALLATION (STANDARD PARTS)</b>	Ref.	
—201	Not Used			
—202	Not Used			
—203	Not Used			
—204	0641406	Bolt 1/4"-20NC x 3/4"	4	
—205	4761400	Lockwasher 1/4"	4	
—206	4751400	Flatwasher 1/4"	4	
—207	3311401	Nut 1/4"-20NC	4	
—208	2560003	Handle	4	
—209	Not Used			
—210	4751000	Flatwasher #10	8	
—211	Not Used			
—212	Not Used			
—213	3820020	Rivet 3/16"	16	
—214	2940062	Latch, Rubber	4	
—215	3820019	Rivet - 3/16"	8	
—216	Not Used			
—217	Not Used			
—218	3760170	Ring	2	
—219	1060379	Cable, Lanyard	2	
—220	2940065	Latch, Snap	2	

# SECTION 11-2 GROUND COMPONENTS CM2033/CM2046/CM2546/CM2558

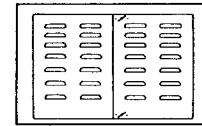

**SECTION 11 - 2 GROUND COMPONENTS**

FIGURE & ITEM NO	PART NUMBER	DESCRIPTION	QTY.	REV.
11—2—1		<b>COVERS, CONTROLS, TANK AND VALVES INSTALLATION (CONTINUED)</b>	Ref.	
	0251212	<b>COVERS INSTALLATION - CM2033 (NOT SHOWN) (VARIABLE PARTS)</b>	Ref.	B
—251	4060762	Cover (RH)	1	
—252	4060763	Cover (LH)	1	
—253	4060764	Support, Shield	2	
	0251390	<b>COVERS INSTALLATION - CM2046, CM2546 AND CM2558 (VARIABLE PARTS)</b>	Ref.	B
—251	4060771	Cover (RH)	1	
—252	4060772	Cover (LH)	1	
—253	4060773	Support, Shield	2	
	0254479	<b>TUV COMPONENTS INSTALLATION</b>	Ref.	A
—301	2901207	Motor Band Kit	1	
—302	3252140	Decal - Ground	2	
—303	3535590	Cover	1	
—304	0641408	Bolt 1/4"-20NC x 1"	2	
—305	3311401	Nut 1/4"-20NC	2	
—306	4761400	Lockwasher 1/4"	2	
—307	Not Used			
—308	2820035	Loom (Not Shown - Located on Battery Charger Cables)	4 ft./1.em	
	0254883	<b>HOURMETER AT FRAME INSTALLATION (NOT SHOWN)</b>	Ref.	A
	2900865	Hourmeter At Frame Kit	1	
	0902061	Bracket	1	
	4921665	Harness	1	
	2420161	Gauge, Hourmeter	1	

# SECTION 11-2 GROUND COMPONENTS CM2033/CM2046/CM2546/CM2558

FIGURE 11-2-2. CONTROL VALVE ASSEMBLY - HYDRO-AIR  
(MACHINES WITH BANG-BANG DRIVE BUILT PRIOR TO JUNE 1992).

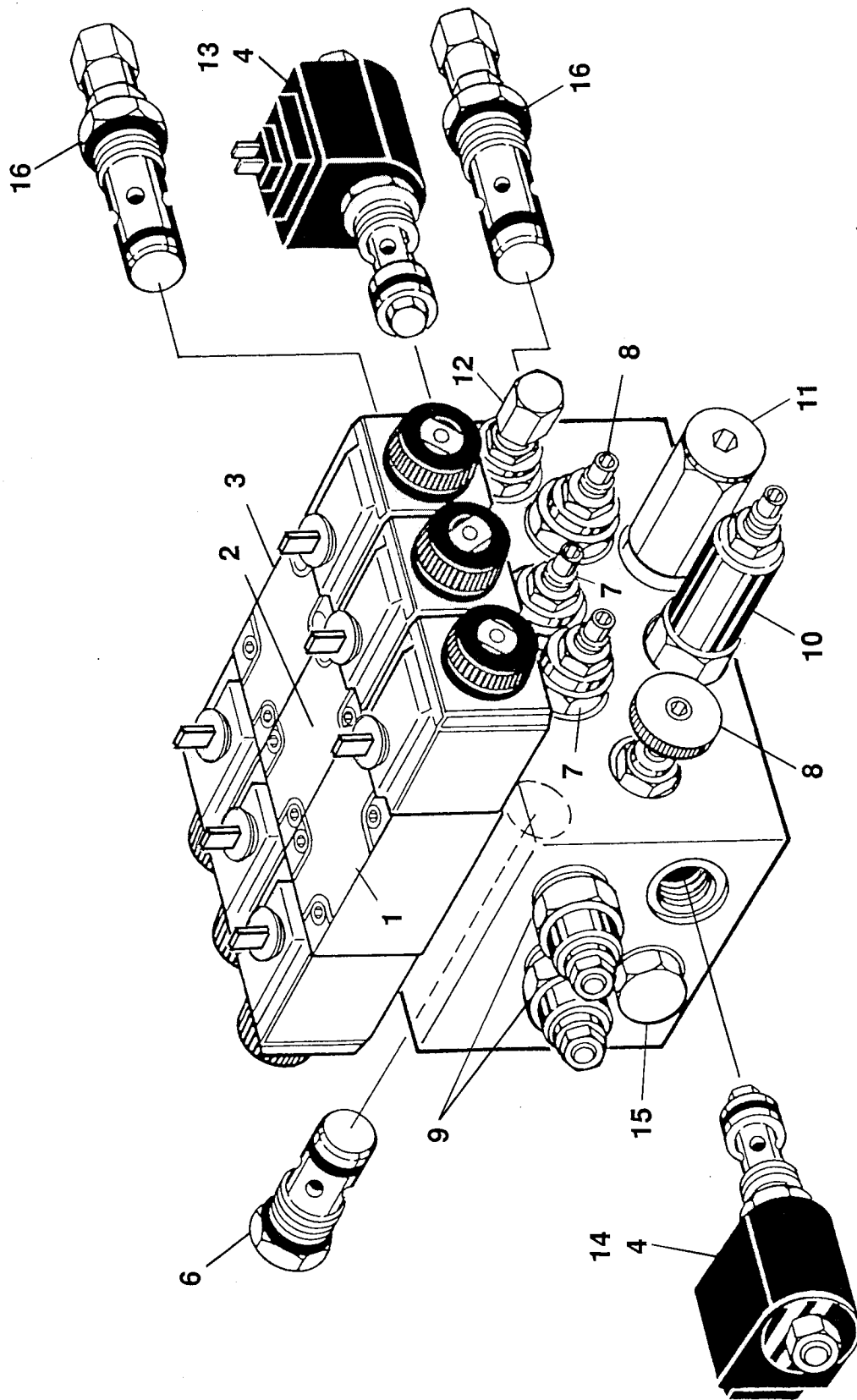
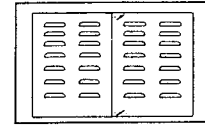

# SECTION 11-2 GROUND COMPONENTS CM2033/CM2046/CM2546/CM2558

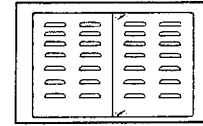
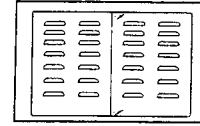

FIGURE & ITEM NO	PART NUMBER	DESCRIPTION	QTY.	REV.
11—2—2	4640657	<b>CONTROL VALVE ASSEMBLY - HYDRO-AIR (MACHINES WITH BANG-BANG DRIVE BUILT PRIOR TO JUNE 1992)</b>	Ref.	A
		<b>NOTE: IDENTIFY BY P/N STAMPED ON THE FOLLOWING COMPONENTS BEFORE ORDERING REPLACEMENT PARTS. SHAPE OF COMPONENTS MAY VARY.</b>		
—1	4640737	Rexroth Directional Valve Assembly (Drive)	1	
	7012726	Coil (Rexroth)	2	
	7012725	Seal Kit (Rexroth)	1	
	Not Available	Vickers Directional Valve Assembly (Drive) (No Longer Available Replace with P/N 4640737)	1	
	7010534	Coil (Vickers)	2	
—2	4640737	Rexroth Directional Valve Assembly (Lift/Hi-Drive)	1	
	7012726	Coil (Rexroth)	2	
	7012725	Seal Kit (Rexroth)	1	
	Not Available	Vickers Directional Valve Assembly (Lift/Hi-Drive) (No Longer Available. Replace with P/N 4640737)	1	
	7010534	Coil (Vickers)	2	
—3	4640740	Rexroth Directional Valve Assembly (Steer)	1	
	7012727	Coil (Rexroth)	2	
	7012725	Seal Kit (Rexroth)	1	
	Not Available	Vickers Directional Valve Assembly (Steer) (No Longer Available. Replace with P/N 4640740)	1	
	7010534	Coil (Vickers)	2	
—4	7012900	Coil - 20 Volt (Hydraforce)	2	
	7004370	Coil - 18 Volt (Vickers/Modular Controls)	2	
—5	Not Used			
—6	7010561	Valve, Check (Vickers/Modular Controls CV1-10-B-05)	1	
	2900503	Seal Kit (Vickers/Modular Controls CV1-10-B-05)	1	
	7012930	Valve, Check (Hydraforce CV10-20-0-N-5)	1	
	2900756	Seal Kit (Hydraforce CV10-20-0-N-5)	1	
—7	7010565	Valve, Flow Control (Vickers/Modular Controls FCV6-10-S-0-FF) (Brake Speed and Lift/Lower Speed Adjustments)	2	
	2900503	Seal Kit (Vickers/Modular Controls FCV6-10-S-0-FF) (1 Per Cartridge)	2	
	7010544	Valve, Flow Control (Hydraforce FC10-20A-0-N) (Brake Speed and Lift/Lower Speed Adjustments)	2	
	7012901	Seal Kit (Hydraforce FC10-20A-0-N) (1 Per Cartridge)	2	
—8	7010567	Valve, Needle (Vickers/Modular Controls FCV6-10-S-0-NV) (Tow and Creep Adjustments)	2	
	2900502	Seal Kit (Vickers/Modular Controls FCV6-10-S-0-NV) (1 Per Cartridge)	2	
	7012933	Valve, Needle (Hydraforce NV10-20A-0-N) (Tow and Creep Adjustments)	2	
	7012901	Seal Kit (Hydraforce NV10-20A-0-N) (1 Per Cartridge)	2	

**SECTION 11 - 2 GROUND COMPONENTS**

# SECTION 11-2 GROUND COMPONENTS CM2033/CM2046/CM2546/CM2558



SECTION 11-2 GROUND COMPONENTS

FIGURE & ITEM NO	PART NUMBER	DESCRIPTION	QTY.	REV.
11—2—2	4640657	<b>CONTROL VALVE ASSEMBLY - HYDRO-AIR (MACHINES WITH BANG-BANG DRIVE BUILT PRIOR TO JUNE 1992)</b>	Ref.	A
—9	7004361	Valve, Load Control (Drive Motion Adjustments)	2	
	2900706	Seal Kit (1 Per Cartridge)	2	
—10	7010564	Valve, Sequence (Vickers/Modular Controls PSV2-10-S-0-12) (Hi-Drive Kickout Adjustment) (Cartridge must be adjusted to 1100 PSI when installed)	1	
	2900698	Seal Kit (Vickers/Modular Controls PSV2-10-S-0-12)	1	
	7012934	Valve Sequence (Hydraforce PS10-32A-0-N-15/11) (HI-Drive Kickout Adjustment)	1	
	2900707	Seal Kit (Hydraforce PS10-32A-0-N-15/11)	1	
—11	4640642	Valve, Relief (Vickers/Modular Controls RV1-10-I-0-36/26) (P1 Relief Pressure Adjustment)	1	
	2900503	Seal Kit (Vickers/Modular Controls RV1-10-I-0-36/26)	1	
	7012932	Valve, Relief (Hydraforce RV10-20H-0-N-33/27) (Pin (P1 Relief Pressure Adjustment)	1	
	2900708	Seal Kit (Hydraforce RV10-20H-0-N-33/27)	1	
—12	7010562	Valve, Relief (Vickers/Modular Controls RV6-10-C-0-25) (P2 Relief Pressure Adjustment) (Cartridge must be adjusted to 2700 PSI when installed)	1	
	2900503	Seal Kit (Vickers/Modular Controls RV6-10-C-0-25)	1	
	7012932	Valve, Relief (Hydraforce RV10-20H-0-N-33/27) (P2 Relief Pressure Adjustment)	1	
	2900708	Seal Kit (Hydraforce RV10-20H-0-N-33/27)	1	
—13	7010536	Valve, Solenoid - Less Coil (Mid-Drive) (Vickers/ Modular Controls SV3-10-4-0-00) (Order Coil separately - Manufacturer of the cartridge and the coil must be the same)	1	
	2900696	Seal Kit (Vickers/Modular Controls SV3-10-4-0-00)	1	
	7012920	Valve, Solenoid - Less Coil (Mid-Drive) (Hydraforce SV10-25-0-N-00) (Order Coil separately - Manufacturer of the cartridge and coil must be the same)	1	
	2900708	Seal Kit (Hydraforce SV10-25-0-N-00 and SV10-25-0-N-20DS)	1	
—14	7009744	Valve, Solenoid - Less Coil (Positive Traction) (Vickers/ Modular Controls SV4-10-0-00) (Order Coil separately - Manufacturer of the cartridge and the coil must be the same)	1	
	2900502	Seal Kit (Vickers/Modular Controls SV4-10-0-0-00)	1	
	7012919	Valve, Solenoid - Less Coil (Positive Traction) (Hydraforce SV10-42-0-N-00) (Order Coil separately - manufacturer of the cartridge and coil must be the same)	1	
	7012903	Seal Kit (Hydraforce SV10-42-0-N-20DS and SV10-42-0-N-00)	1	



**SECTION 11-2 GROUND COMPONENTS  
CM2033/CM2046/CM2546/CM2558**

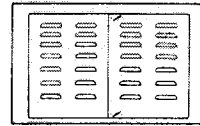

FIGURE & ITEM NO	PART NUMBER	DESCRIPTION	QTY.	REV.
11—2—2	4640657	<b>CONTROL VALVE ASSEMBLY - HYDRO-AIR (MACHINES WITH BANG-BANG DRIVE BUILT PRIOR TO JUNE 1992) (CONTINUED)</b>	Ref.	A
—15	7010503	Valve, Flow Divider (Vickers/Modular Controls FDC1-10-0-44)	1	
	2900696	Seal Kit (Vickers/Modular Controls FDC1-10-0-44)	1	
	7012929	Valve, Flow Divider (Hydraforce FD10-40-0-N-44)	1	
	7012904	Seal Kit (Hydraforce FD10-40-0-N-44)		
—16	7010562	Valve, Relief (Vickers/Modular Controls RV6-10-C-025) (Steer Relief Adjustments) (Cartridge must be adjusted 1500 PSI when installed.)	2	
	2900503	Seal Kit (Vickers/Modular Controls RV6-10-0-25) (1 Per Cartridge)	2	
	7012931	Valve, Relief (Hydraforce RV10-20H-0-N-33/15 and RV10-26H-0-N-30/15) (Steer Relief Adjustments)	2	
	2900708	Seal Kit (Hydraforce RV10-20H-0-N-33/15 and RV10-26H-0-N-30/15) (1 Per Cartridge)	2	
	0251719	<b>LIFT OVERLOAD VALVE INSTALLATION (1991 FRENCH SPEC MODELS ONLY) (NOT SHOWN)</b>	Ref.	—
	4640694	Valve, Relief	1	
	2900785	Seal Kit	1	
	3931048	Bolt, Socket Head #10-24NC x 3"	4	

**SECTION 11 - 2 GROUND COMPONENTS**

# SECTION 11-2 GROUND COMPONENTS CM2033/CM2046/CM2546/CM2558

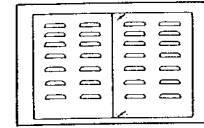
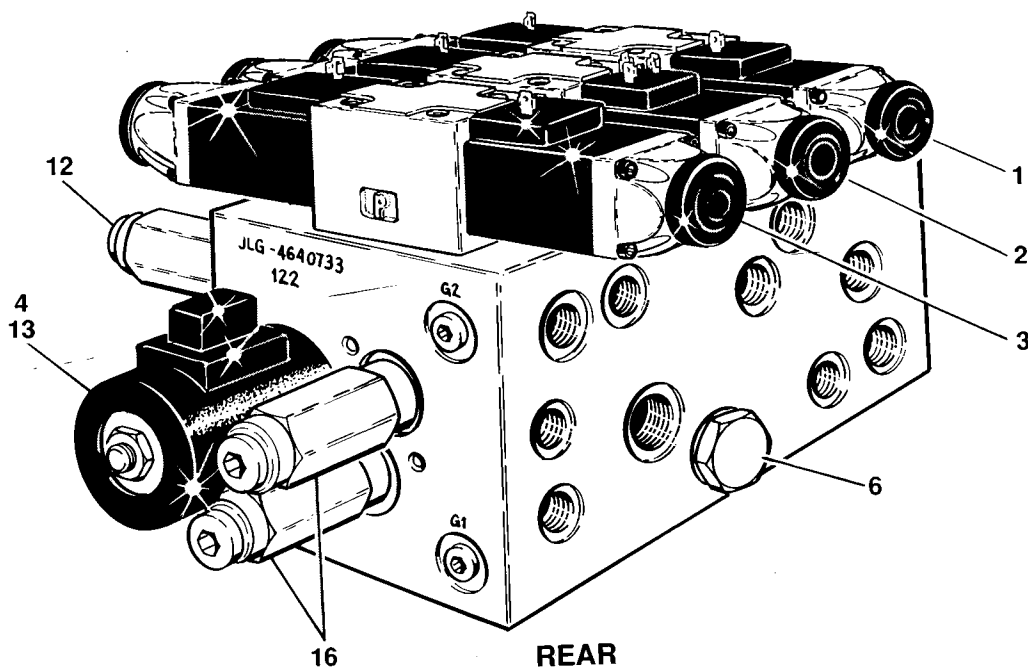
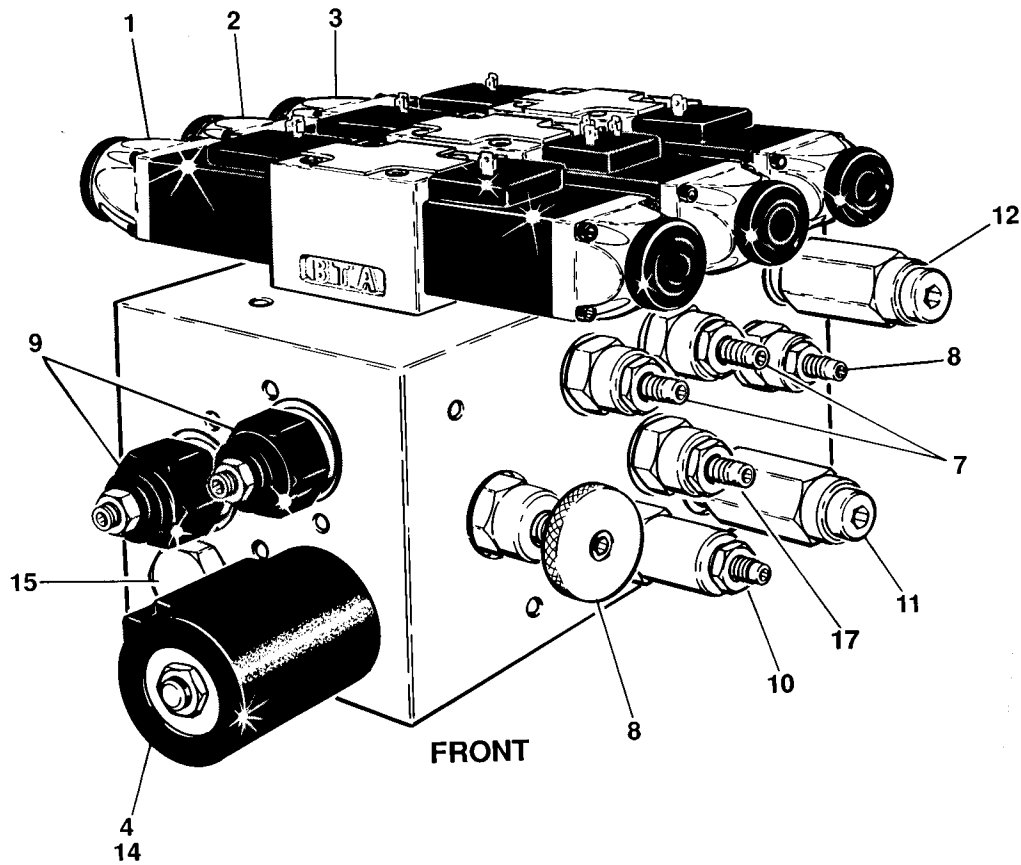
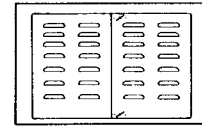

FIGURE 11-2- 3. CONTROL VALVE ASSEMBLY - HYDRO-AIR  
(MACHINES WITH BANG-BANG DRIVE BUILT JUNE 1992 TO PRESENT).



# SECTION 11-2 GROUND COMPONENTS CM2033/CM2046/CM2546/CM2558



**SECTION 11 - 2 GROUND COMPONENTS**

FIGURE & ITEM NO	PART NUMBER	DESCRIPTION	QTY.	REV.
11—2—3	4640733	<b>CONTROL VALVE ASSEMBLY - HYDRO-AIR (MACHINES WITH BANG-BANG DRIVE BUILT JUNE 1992 TO PRESENT)</b>	Ref.	A
—1	4640737	Rexroth Directional Valve Assembly (Drive)	1	
	7012726	Coil (Rexroth)	2	
	7012725	Seal Kit (Rexroth)	1	
—2	4640745	Rexroth Directional Valve Assembly (Lift/Hi-Drive)	1	
	7012726	Coil - 1 Prong (Rexroth)	1	
	7012732	Coil - 3 Prong (Rexroth)	1	
	7012725	Seal Kit (Rexroth)	1	
—3	4640740	Rexroth Directional Valve Assembly (Steer)	1	
	7012727	Coil (Rexroth)	2	
	7012725	Seal Kit (Rexroth)	1	
—4	7012900	Coil - 20 Volt (Hydraforce)	2	
—5	Not Used			
—6	7012930	Valve, Check	1	
	2900756	Seal Kit (Hydraforce CV10-20-0-N-5)	1	
—7	7010544	Valve, Flow Control (Brake Speed and Lift/Lower Speed Adjustments)	2	
	7012901	Seal Kit (Hydraforce FC10-20A-0-N) (1 Per Cartridge)	2	
—8	7012933	Valve, Needle (Tow and Creep Adjustments)	2	
	7012901	Seal Kit (Hydraforce NV10-20A-0-N) (1 Per Cartridge)	2	
—9	7004361	Valve, Load Control (Drive Motion Adjustments)	2	
	2900706	Seal Kit (1 Per Cartridge)	2	
—10	7012934	Valve, Sequence (Hi-Drive Kickout Adjustment)	1	
	2900707	Seal Kit (Hydraforce PS10-32A-0-N-15/11)	1	
—11	7012932	Valve, Relief (P1 Relief Pressure Adjustment) (Hydraforce Version)	1	
	2900708	Seal Kit (Hydraforce RV10-20H-0-N-33/27)	1	
—12	7012932	Valve, Relief (P2 Relief Pressure Adjustment)	1	
	2900708	Seal Kit (Hydraforce RV10-20H-0-N-33/27)	1	
—13	7012920	Valve, Solenoid - Less Coil (Mid-Drive) (Hydraforce SV10-25-0-N-00) (Order Coil Separately)	1	
	2900708	Seal Kit	1	
—14	7012919	Valve, Solenoid - Less Coil (Positive Traction) (Hydraforce SV10-42-0-N-00) (Order Coil Separately)	1	
	7012903	Seal Kit	1	



**SECTION 11-2 GROUND COMPONENTS  
CM2033/CM2046/CM2546/CM2558**

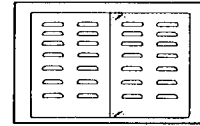

FIGURE & ITEM NO	PART NUMBER	DESCRIPTION	QTY.	REV.
11—2—3	4640733	<b>CONTROL VALVE ASSEMBLY - HYDRO-AIR (MACHINES WITH BANG-BANG DRIVE BUILT JUNE 1992 TO PRESENT) (CONTINUED)</b>	Ref.	A
—15	7012929	Valve, Flow Divider	1	
	7012904	Seal Kit (Hydraforce FD10-40-0-N-44)		
—16	7012931	Valve, Relief (Steer Relief Adjustments)	2	
	2900708	Seal Kit (Hydraforce RV10-20H-N-33/15 and RV10-26H-N-30/15) (1 PerCartridge)	2	
—17	7012912	Valve, Relief (Lift Relief Pressure) (Machines built after June 1993 Only)	1	
	7010541	Seal Kit (Hydraforce RV08-20A-0-N-33)	1	

**SECTION 11 - 2 GROUND COMPONENTS**



# SECTION 11-2 GROUND COMPONENTS

## CM2033/CM2046/CM2546/CM2558

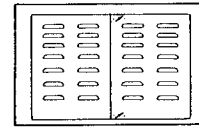

SECTION 11 - 2 GROUND COMPONENTS

FIGURE & ITEM NO	PART NUMBER	DESCRIPTION	QTY.	REV.
11—2—4	0252689	<b>CONTROL VALVE ASSEMBLY - HYDRO-AIR (MACHINES WITH PROPORTIONAL DRIVE)</b>	Ref.	A
		<b>CONTROL VALVE ASSEMBLY (INCLUDES ITEMS 1-16)</b>	Ref.	
		<b>NOTE: Identify by P/N stamped on the following components before ording replacement parts. Shape of components may vary.</b>		
—1	Not Used			
—2	4640745	Rexroth Directional Valve Assembly (Lift/Hi-Drive)	1	
	7012726	Coil - 1 Prong (Rexroth)	1	
	7012732	Coil - 3 Prong (Rexroth)	1	
	7012725	Seal Kit (Rexroth)	1	
—3	4640740	Rexroth Directional Valve Assembly (Steer)	1	
	7012727	Coil (Rexroth)	2	
	7012725	Seal Kit (Rexroth)	1	
—4	7012900	Coil - 20 Volt (Hydraforce)	2	
—5	Not Used			
—6	7012930	Valve, Check	1	
	2900756	Seal Kit (Hydraforce CV10-20-0-N-5)	1	
—7	7010544	Valve, Flow Control (Brake Speed and Lift/Lower Speed Adjustments)	2	
	7012901	Seal Kit (Hydraforce FC10-20A-0-N) (1 Per Cartridge)	2	
—8	7012933	Valve, Needle (Tow and Creep Adjustments)	2	
	7012901	Seal Kit (Hydraforce NV10-20A-0-N) (1 Per Cartridge)	2	
—9	7004361	Valve, Load Control (Drive Motion Adjustments)	2	
	2900706	Seal Kit (1 Per Cartridge)	2	
—10	7012934	Valve, Sequence (Hi-Drive Kickout Adjustment)	1	
	2900707	Seal Kit (Hydraforce PS10-32A-0-N-15/11)	1	
—11	7012932	Valve, Relief (P1 Relief Pressure Adjustment) (Hydraforce Version)	1	
	2900708	Seal Kit (Hydraforce RV10-20H-0-N-33/27)	1	
—12	7012932	Valve, Relief (P2 Relief Pressure Adjustment)	1	
	2900708	Seal Kit (Hydraforce RV10-20H-0-N-33/27)	1	
—13	7012920	Valve, Solenoid - Less Coil (Mid-Drive) (Hydraforce SV10-25-0-N-00) (Order Coil Separately)	1	
	2900708	Seal Kit	1	
—14	7012919	Valve, Solenoid - Less Coil (Positive Traction) (Hydraforce SV10-42-0-N-00) (Order Coil Separately)	1	
	7012903	Seal Kit	1	





# SECTION 11-2 GROUND COMPONENTS CM2033/CM2046/CM2546/CM2558

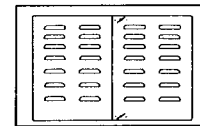
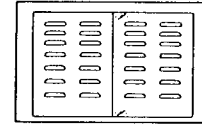

FIGURE & ITEM NO	PART NUMBER	DESCRIPTION	QTY.	REV.
11—2—4	0252689	<b>CONTROL VALVE ASSEMBLY - HYDRO-AIR (MACHINES WITH PROPORTIONAL DRIVE) (CONTINUED)</b>	Ref.	A
—15	7012929	Valve, Flow Divider	1	
	7012904	Seal Kit (Hydraforce FD10-40-0-N-44)		
—16	7012931	Valve, Relief (Steer Relief Adjustments)	2	
	2900708	Seal Kit (Hydraforce RV10-20H-N-33/15and RV10-26H-N-30/15) (1 Per Cartridge)	2	
—17	7012912	Valve, Relief (Lift Relief Pressure) (Machines built after June 1993 Only)	1	
	7010541	Seal Kit (Hydraforce RV08-20A-0-N-33)	1	
—100	4640736	<b>LOAD SENSING VALVE ASSEMBLY</b>	Ref.	—
—101	7010511	Valve, Load Sensing (Modular Controls DPS2-2907)	1	
	2900735	Seal Kit (Modular Controls DPS2-2907)	1	
—102	7010566	Valve, Check (Modular Controls DSV1-10-B-0)	1	
	2900697	Seal Kit (Modular Controls DSV1-10-B-0)	1	
	7012935	Valve, Check (Hydraforce LS10-30-0-N)	1	
	7012518	Seal Kit (Hydraforce LS10-30-0-N)	1	
—200	4640714	<b>PROPORTIONAL DRIVE VALVE ASSEMBLY</b>	Ref.	—
	7012308	Coil	2	
	7012311	Seal Kit	1	
	7012312	Mounting Kit	1	

SECTION 11-2 - GROUND COMPONENTS

# SECTION 11-2 GROUND COMPONENTS CM2033/CM2046/CM2546/CM2558

FIGURE 11-2-5. BATTERIES AND CHARGERS INSTALLATION.



SECTION 11 - 2 GROUND COMPONENTS

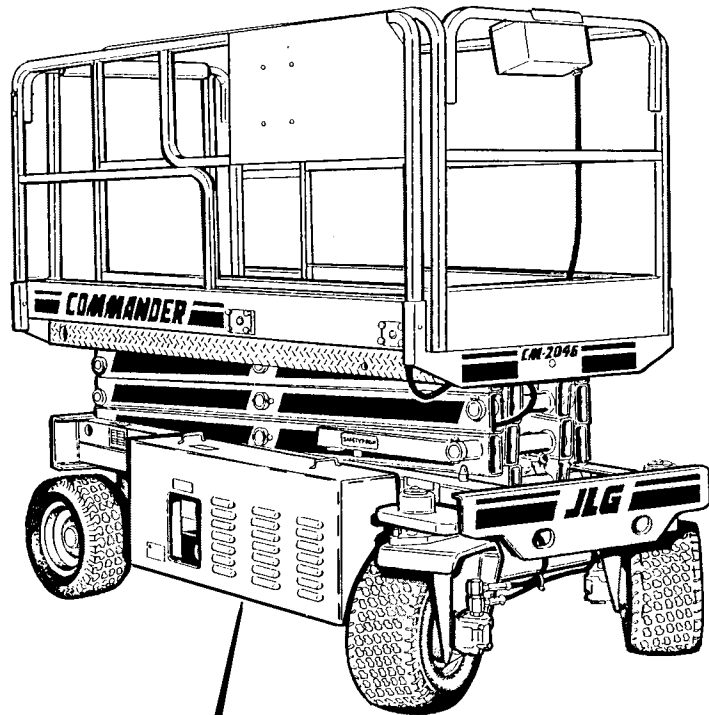
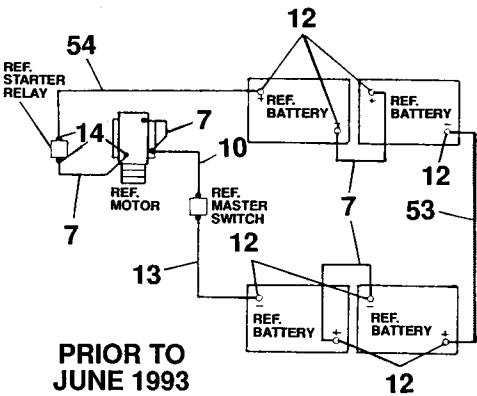
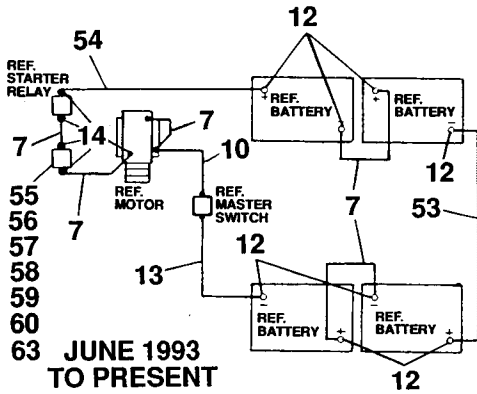

NOTE: CM2046 SHOWN USE AS A REFERENCE FOR OTHER MODELS

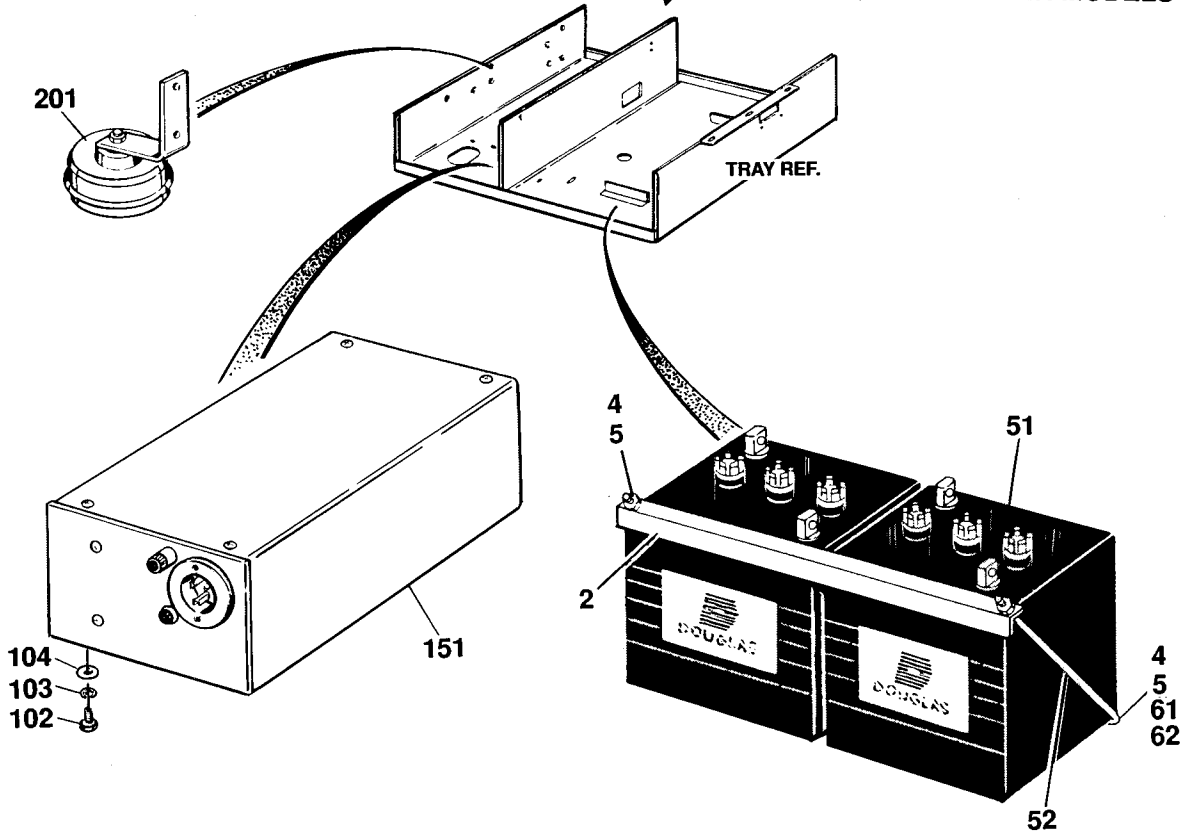

# SECTION 11-2 GROUND COMPONENTS CM2033/CM2046/CM2546/CM2558

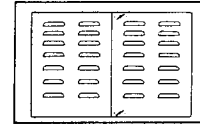

**SECTION 11 - 2 GROUND COMPONENTS**

FIGURE & ITEM NO	PART NUMBER	DESCRIPTION	QTY.	REV.
11-2-5		<b>BATTERIES AND CHARGERS INSTALLATION</b>	Ref.	
	1281464	<b>BATTERIES INSTALLATION (STANDARD PARTS)</b>	Ref.	G
-1	Not Used			
-2	0181583	Angle, Mounting	2	
-3	Not Used			
-4	4751400	Flatwasher 1/4"	4	
-5	3311405	Locknut 1/4"-20NC	4	
-6	Not Used			
-7	1060221	Cable, Battery - 12 in./30.5cm Length	A/R	
-8	Not Used			
-9	Not Used			
-10	1060080	Cable, Battery - 30 in./76cm Length	1	
-11	Not Used			
-12	0840031	Boot, Terminal	8	
-13	1060130	Cable, Battery - 22 in./56cm Length	1	
-14	0840025	Boot, Terminal	A/R	
	0251354	<b>BATTERIES INSTALLATION - CM2033 BUILT PRIOR TO JUNE 1993 (VARIABLE PARTS)</b>	Ref.	I
-51	0400069	Battery (Wet Standard) (Douglas 6V-225)	4	
	0400112	Battery (Dry Standard) (Douglas 6V-225)	4	
-52	3841069	Rod, Holddown	4	
-53	1060364	Cable, Battery - 30 in./76cm Length	1	
-54	1060365	Cable, Battery - 48 in./122cm Length	1	
-55 to -63	Not Required			
	0254209	<b>BATTERIES INSTALLATION - CM2033 BUILT JUNE 1993 TO PRESENT (VARIABLE PARTS)</b>	Ref.	B
-51	0400069	Battery (Wet Standard) (Douglas 6V-225)	4	
	0400112	Battery (Dry Standard) (Douglas 6V-225)	4	
-52	3841069	Rod, Holddown	4	
-53	1060054	Cable, Battery - 36 in./40.6cm Length	1	
-54	1060149	Cable, Battery - 54 in./122cm Length	1	
-55	2400041	Fuse - 200 Amp	1	
-56	2400044	Fuseholder	1	
-57	0741008	Screw, Countersunk #10 x 1"	2	
-58	4761000	Lockwasher #10	2	
-59	3311005	Locknut #10	2	
-60	0840025	Boot, Terminal	2	
-61	Not Required			
-62	Not Required			
-63	4751500	Flatwasher 5/16"	4	

# SECTION 11-2 GROUND COMPONENTS CM2033/CM2046/CM2546/CM2558

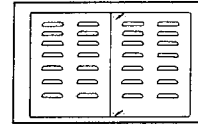

SECTION 11-2 GROUND COMPONENTS

FIGURE & ITEM NO	PART NUMBER	DESCRIPTION	QTY.	REV.
11-2-5		<b>BATTERIES AND CHARGERS INSTALLATION (CONTINUED)</b>	Ref.	
	0251352	<b>BATTERIES INSTALLATION - CM2046, CM2546 AND CM2558 WITH STANDARD BATTERIES (VARIABLE PARTS)</b>	Ref.	H
-51	0400069	Battery (Wet Standard) (Douglas 6V-225)	4	
	0400112	Battery (Dry Standard) (Douglas 6V-225)	4	
-52	3841069	Rod, Holddown	4	
-53	1060054	Cable, Battery - 36 in./96.5cm Length	1	
-54	1060149	Cable, Battery - 54 in./137cm Length	1	
-55 to -63	Not Required			
	0254250/0254210	<b>BATTERIES INSTALLATION - CM2046, CM2546 AND CM2558 WITH STANDARD BATTERIES BUILT JUNE 1993 TO PRESENT (VARIABLE PARTS)</b>	Ref.	A/B
-51	0400069	Battery (Wet Standard) (Douglas 6V-225)	4	
	0400112	Battery (Dry Standard) (Douglas 6V-225)	4	
-52	3841069	Rod, Holddown	4	
-53	1060054	Cable, Battery - 36 in./96.5cm Length	1	
-54	1060149	Cable, Battery - 54 in./137cm Length	1	
-55	2400041	Fuse - 200 Amp	1	
-56	2400044	Fuseholder	1	
-57	0741008	Screw, Countersunk #10 x 1"	2	
-58	4761000	Lockwasher #10	2	
-59	3311005	Locknut #10	2	
-60	0840025	Boot, Terminal	2	
-61	0641408	Bolt 1/4"-20NC x 1" (CM2046 Only)	4	
-62	0181722	Angle, Mounting (CM2046 Only)	2	
-63	4751500	Flatwasher 5/16"	4	
	0251353	<b>BATTERIES INSTALLATION - CM2046, CM2546 AND CM2558 WITH HI-OUTPUT BATTERIES BUILT PRIOR TO JUNE 1993 (VARIABLE PARTS)</b>	Ref.	H
-51	0400055	Battery (Wet Hi-Output) (Douglas 6V-370-S)	4	
	0400107	Battery (Dry Hi-Output) (Douglas 6V-370-S)	4	
-52	3841094	Rod, Holddown	4	
-53	1060054	Cable, Battery - 36 in./91.5cm Length	1	
-54	1060149	Cable, Battery - 54 in./137cm Length	1	
-55 to -63	Not Required			
	0254251/0254211	<b>BATTERIES INSTALLATION - CM2046, CM2546 AND CM2558 WITH HI-OUTPUT BATTERIES BUILT JUNE 1993 TO PRESENT (VARIABLE PARTS)</b>	Ref.	A/B
-51	0400055	Battery (Wet Hi-Output) (Douglas 6V-370-S)	4	
	0400107	Battery (Dry Hi-Output) (Douglas 6V-370-S)	4	

# SECTION 11-2 GROUND COMPONENTS CM2033/CM2046/CM2546/CM2558

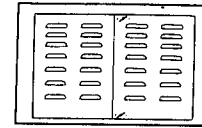

**SECTION 11 - 2 GROUND COMPONENTS**

FIGURE & ITEM NO	PART NUMBER	DESCRIPTION	QTY.	REV.
11-2-5		<b>BATTERIES AND CHARGERS INSTALLATION (CONTINUED)</b>	5	
—52	3841094	Rod, Holddown	4	
—53	1060054	Cable, Battery - 36 in./91.5cm Length	1	
—54	1060149	Cable, Battery - 54 in./137cm Length	1	
—55	2400041	Fuse - 200 Amp	1	
—56	2400044	Fuseholder	1	
—57	0741008	Screw, Countersunk #10 x 1"	2	
—58	4761000	Lockwasher #10	2	
—59	3311005	Locknut #10	2	
—60	0840025	Boot, Terminal	2	
—61	0641408	Bolt 1/4"-20NC x 1" (CM2046 Only)	4	
—62	0181722	Angle, Mounting (CM2046 Only)	2	
—63	4751500	Flatwasher 5/16"	4	
		<b>BATTERY CHARGER INSTALLATION (STANDARD PARTS)</b>	Ref.	
—101	Not Used			
—102	0641406	Bolt 1/4"-20NC x 3/4"	2	
—103	4761400	Lockwasher 1/4"	2	
—104	4751400	Flatwasher 1/4"	2	
	0251721	<b>BATTERY CHARGER INSTALLATION - 220 SINGLE VOLTAGE (ALL EXCEPT UK AND AUSTRALIAN SPEC) (VARIABLE PARTS)</b>	Ref.	—
—151	0400091	Battery Charger Assembly (See Figure 11-2-6 for Breakdown)	1	
	0253703	<b>BATTERY CHARGER INSTALLATION - 250 SINGLE VOLTAGE (UK SPEC - ALL AND AUSTRALIAN SPEC - PRIOR TO OCTOBER 1994) (VARIABLE PARTS)</b>		
—151	0400109	Battery Charger Assembly (See 11-2-6 for Breakdown)	1	
	0255100	<b>BATTERY CHARGER INSTALLATION - 250 SINGLE VOLTAGE (AUSTRALIAN SPEC - OCTOBER 1994 TO PRESENT) (VARIABLE PARTS)</b>		
—151	0400131	Battery Charger Assembly (See 11-2-6 for Breakdown)	1	
	0251749	<b>BATTERY CHARGER INSTALLATION - DUAL VOLTAGE (UK SPEC) (VARIABLE PARTS)</b>	Ref.	—
—161	0400092	Battery Charger Assembly (See Figure 11-2-7 for Breakdown)	1	
	0251788	<b>HORN INSTALLATION - WITH STEEL CONTROL BOX (OPTION)</b>	Ref.	B
	0253465	<b>HORN INSTALLATION - WITH MOLDED CONTROL BOX (OPTION)</b>	Ref.	A
—201	0140022	Alarm, Horn	1	

# SECTION 11-2 GROUND COMPONENTS CM2033/CM2046/CM2546/CM2558

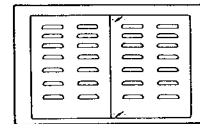
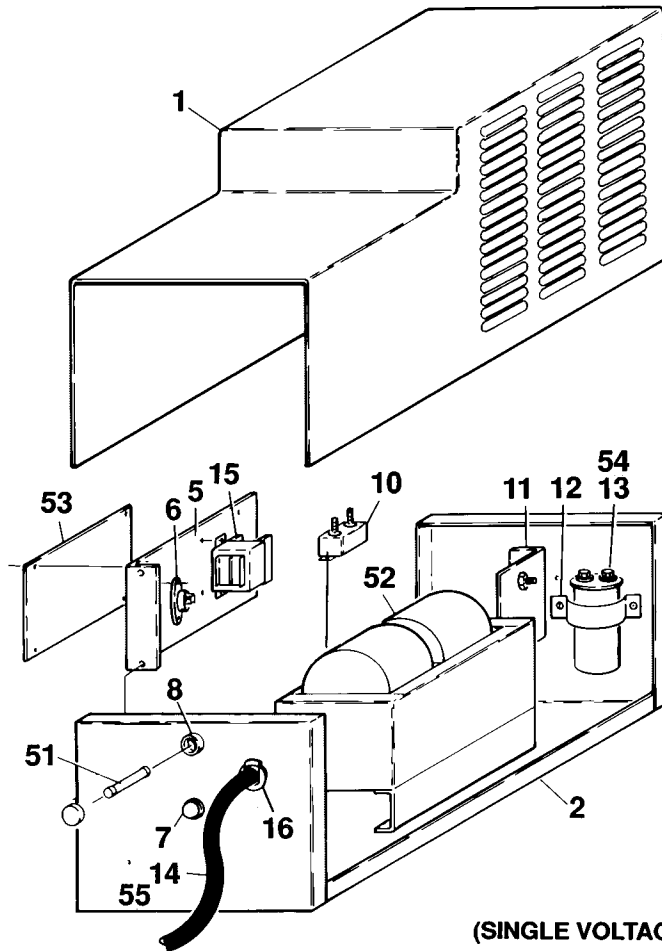
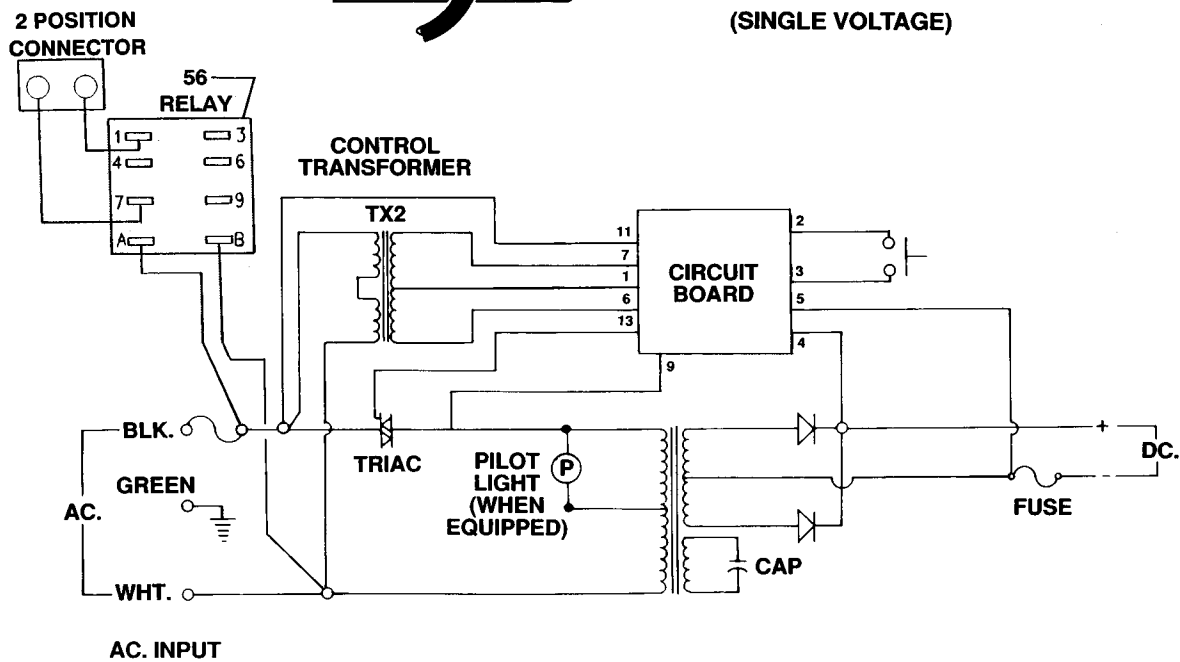

FIGURE 11-2-6. BATTERY CHARGER ASSEMBLY - SINGLE VOLTAGE.

SECTION 11-2 GROUND COMPONENTS



(SINGLE VOLTAGE)



# SECTION 11-2 GROUND COMPONENTS CM2033/CM2046/CM2546/CM2558

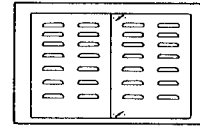

FIGURE & ITEM NO	PART NUMBER	DESCRIPTION	QTY.	REV.
11—2—6		<b>BATTERY CHARGER ASSEMBLY - SINGLE VOLTAGE (STANDARD PARTS)</b> Note: Battery Charger Serial Number Nameplate located on side of Charger. First line is the Charger Spec and Date Code. Example: BA515 (Spec) AP (Date Code). First Letter in the Date Code Indicates Month (A-January/B - February/C-March/ etc. with exception of letter "I" which is not used). Second Letter indicates year (N - 1992/O - 1993/P - 1994/S-1995/etc.)	Ref.	
—1	Not Serviced	Cover, Case	1	
—2	Not Serviced	Case, Main	1	
—3	Not Used			
—4	Not Used			
—5	7011516	Bracket, Mounting - Circuit Board	1	
—6	7011517	Triac	1	
—7	7011506	Light, Pilot (When Equipped)	1	
—8	7011507	Holder, Fuse	1	
—9	Not Used			
—10	7011509	Breaker, Circuit	1	
—11	7011618	Heatsink	1	
	7011559	Diode - 20 Amp	2	
	7011596	Varistor	1	
—12	7011560	Strap, Mounting - Condensor	1	
—13	Not Used			
—14	7011544	Cord, AC	9 ft./1.75m	
—15	7011551	Control	1	
—16	7011528	Strain Relief	1	
	0400091	<b>BATTERY CHARGER ASSEMBLY - 220 SINGLE VOLTAGE (ALL EXCEPT UK AND AUSTRALIAN SPEC) (VARIABLE PARTS)</b>	Ref.	—
—51	7011548	Fuse - 10 Amp	1	
—52	7011533	Transformer	1	
—53	7011617	Board, Circuit without LED Lights - use 7011659 as replacement (Prior to December 1992)	1	
	7011659	Board, Circuit with LED Lights (December 1992 to Present)	1	
—54	7011523	Condensor - 4mfd	1	
—55	Not Required			
—56	Not Required			
	0400109	<b>BATTERY CHARGER ASSEMBLY - 250 SINGLE VOLTAGE (UK SPEC - ALL AND AUSTRALIAN SPEC BUILT PRIOR TO OCTOBER 1994) (VARIABLE PARTS)</b>	Ref.	A
—51	7011657	Fuse - 5 Amp Slo-Blo	1	
—52	7011558	Transformer	1	
—53	7011678	Board, Circuit	1	
—54	7011523	Condensor - 4mfd	1	
	7011543	Condensor - 6mfd	1	
—55	Not Required			
—56	Not Required			

SECTION 11 - 2 GROUND COMPONENTS





# SECTION 11-2 GROUND COMPONENTS CM2033/CM2046/CM2546/CM2558

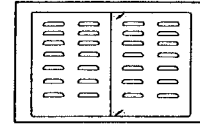

FIGURE & ITEM NO	PART NUMBER	DESCRIPTION	QTY.	REV.
11—2—6		<b>BATTERY CHARGER ASSEMBLY - SINGLE VOLTAGE (STANDARD PARTS) (CONTINUED)</b>	Ref.	
	0400131	<b>BATTERY CHARGER ASSEMBLY - 250 SINGLE VOLTAGE (AUSTRALIAN SPEC - OCTOBER 1994 TO PRESENT)</b>	Ref.	—
—51	7011657	Fuse - 5 Amp Slo-Blo	1	
—52	7011658	Transformer	1	
—53	7011659	Board, Circuit	1	
—54	7011543	Condensor - 6mfd	1	
—55	7011667	Socket, AC	1	
—56	7011684	Relay (September 1995 to Present)	1	

**SECTION 11 - 2 GROUND COMPONENTS**

# SECTION 11-2 GROUND COMPONENTS CM2033/CM2046/CM2546/CM2558

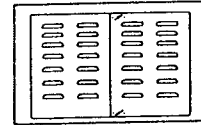
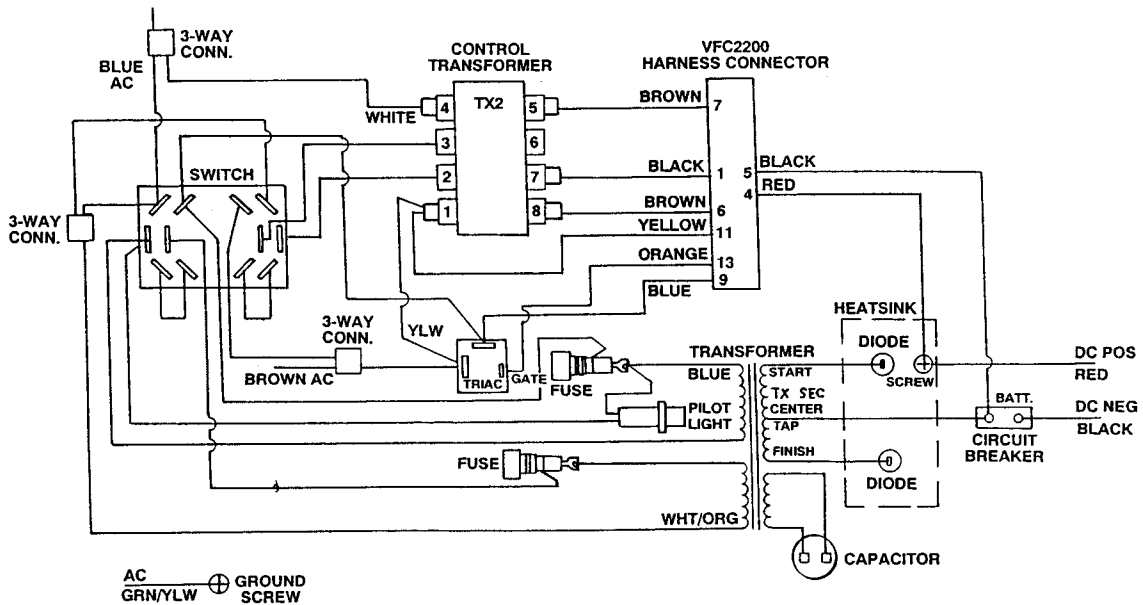
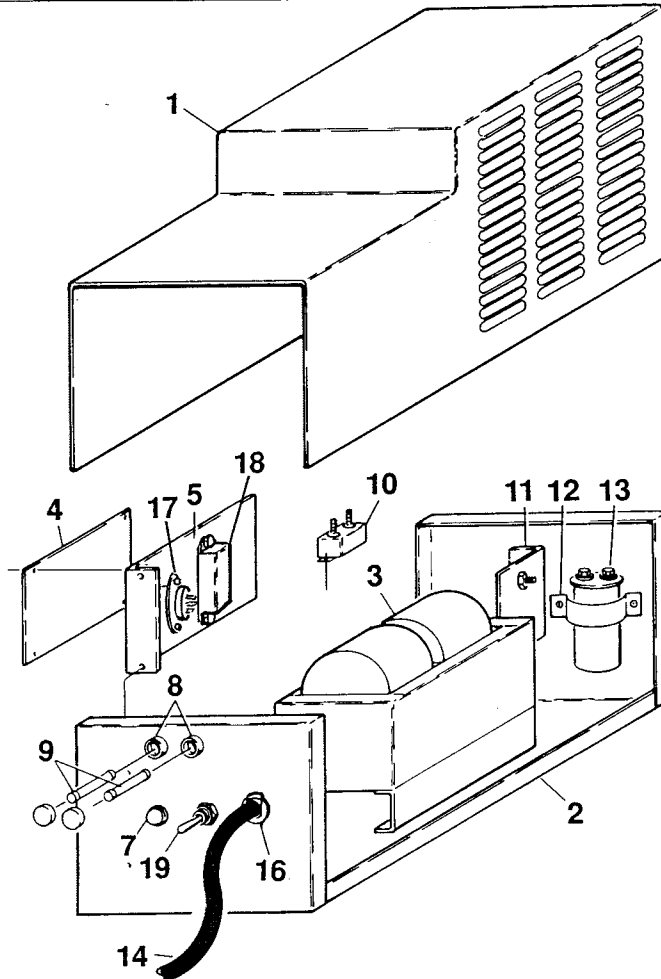

FIGURE 11-2-7. BATTERY CHARGER ASSEMBLY - DUAL VOLTAGE. (UK SPEC ONLY).



# SECTION 11-2 GROUND COMPONENTS CM2033/CM2046/CM2546/CM2558

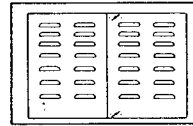
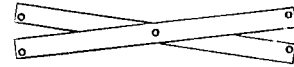

FIGURE & ITEM NO	PART NUMBER	DESCRIPTION	QTY.	REV.
11—2—7	0400092	<b>BATTERY CHARGER ASSEMBLY - DUAL VOLTAGE (UK SPEC ONLY)</b>  <b>Note: Dual Voltage Battery Chargers with date code prior to January 1995 should be replaced as a unit. Consult JLG Industries (Europe) for replacement. Battery Charger Serial Number Nameplate located on side of Charger. The first line is the Charger Spec and Date Code. Example: BA515 (Spec) AP (Date Code). First Letter in the Date Code Indicates Month (A-January/B - February/C-March/etc. with exception of letter "I" which is not used). Second Letter indicates year (N-1992/O - 1993/P-1994/S-1995/etc.)</b>	Ref.	—
—1	Not Serviced	Cover, Case	1	
—2	Not Serviced	Case, Main	1	
—3	7011682	Transformer	1	
—4	7011678	Board, Circuit	1	
—5	7011516	Bracket, Mounting - Circuit Board	1	
—6	Not Used			
—7	7011506	Light, Pilot (When Equipped)	1	
—8	7011507	Holder, Fuse	2	
—9	7011657	Diode - 5 Amp Slo-Blow	2	
—10	7011509	Breaker, Circuit	1	
—11		Heatsink Assembly	1	
	7011559	Diode - 20 Amp	2	
	7011596	Varistor	1	
—12	7011560	Strap, Condenser	1	
—13	7011523	Condenser -4mfd	1	
—14	7011676	Cord, AC (Purchase Receptacle Locally)	8 ft./2.5m	
—15	Not Used		1	
—16	7011528	Connector, Strain Relief	1	
—17	7011517	Triac	1	
—18	7011551	Control, Circuit	1	
—19	7011685	Switch, Toggle - 4PDT	1	



**SECTION 11-3 SIZZOR ARMS  
CM2033/CM2046/CM2546/CM2558**



**TABLE OF CONTENTS**

FIGURE NO.	DESCRIPTION	PAGE NO.
11-3-1	Sizzor Arms Installation - CM2033 and CM2046 .....	11-3-2
11-3-2	Sizzor Arms Installation - CM2546 and CM2558 .....	11-3-6
11-3-3	Sizzor Arms Guards Installation (Prior to August 1992) .....	11-3-10
11-3-4	Sizzor Arms Guards Installation (August 1992 to May 1994) .....	11-3-12
11-3-5	Sizzor Arms Guards Installation (May 1994 to June 1995).....	11-3-14
11-3-6	Sizzor Arms Guards Installation (June 1995 to Present) .....	11-3-16

**S  
E  
C  
T  
I  
O  
N  
  
11  
-  
3  
  
S  
I  
Z  
Z  
O  
R  
  
A  
R  
M  
S**

# SECTION 11-3 SIZZOR ARMS CM2033/CM2046/CM2546/CM2558

FIGURE 11-3-1. SIZZOR ARMS INSTALLATION - CM2033 AND CM2046 (STANDARD PARTS).

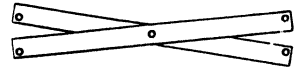

SECTION 11-3 SIZZOR ARMS

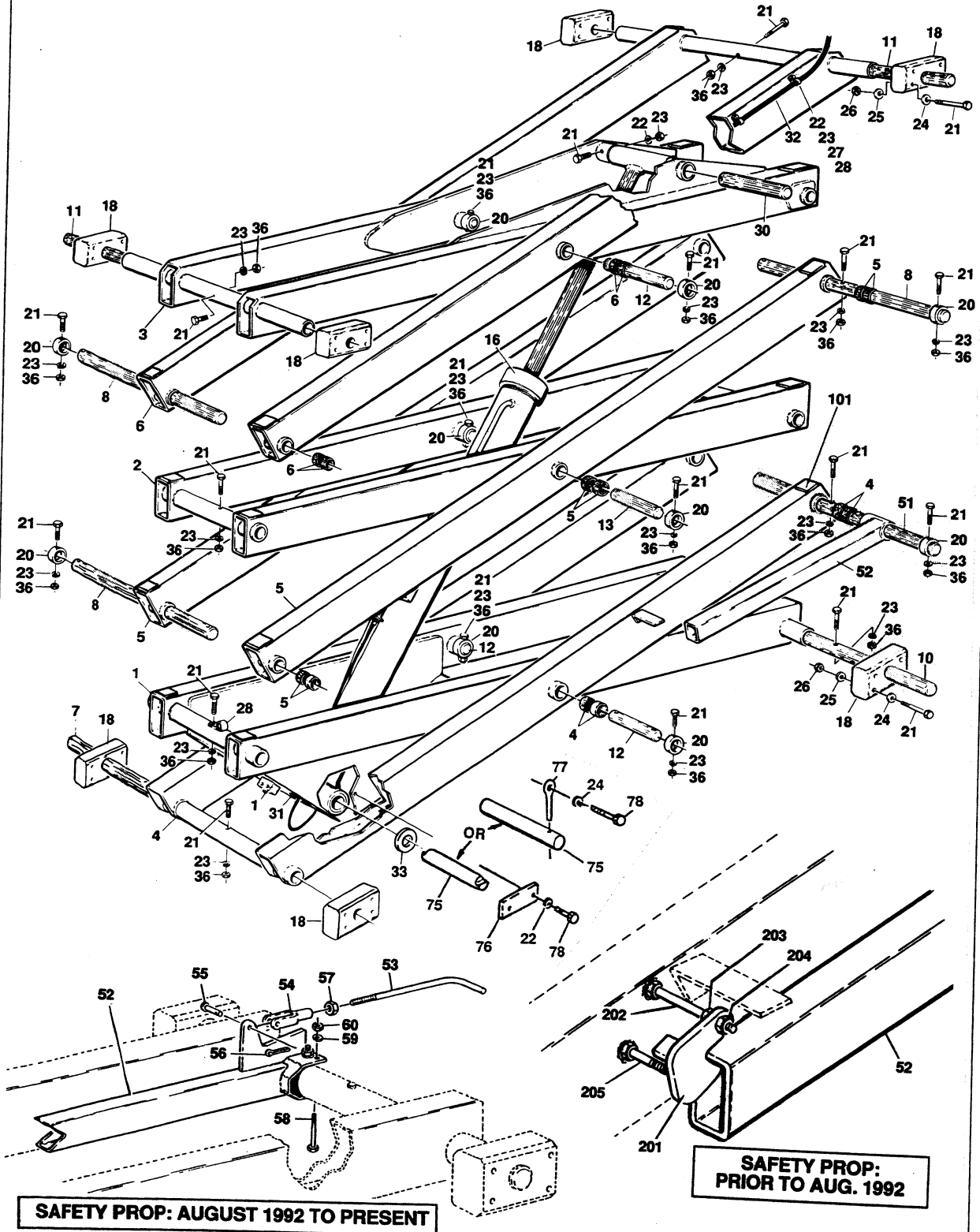

**SECTION 11-3 SIZZOR ARMS  
CM2033/CM2046/CM2546/CM2558**

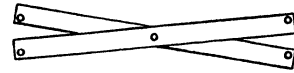

**SECTION 11-3 SIZZOR ARMS**

FIGURE & ITEM NO	PART NUMBER	DESCRIPTION	QTY.	REV.
------------------	-------------	-------------	------	------

FIGURE & ITEM NO	PART NUMBER	DESCRIPTION	QTY.	REV.
11-3-1		<b>SIZZOR ARMS INSTALLATION - CM2033 AND CM2046</b>	Ref.	
		<b>SIZZOR ARMS INSTALLATION (STANDARD PARTS)</b>	Ref.	
-1	2901375	Arms Kit	1	-
	0200416	Arm Weldment (Bottom Inboard)(Prior to March 1993)	1	
	0200508	Arm Weldment (Bottom Inboard)(March 1993 to Present)	1	
-2	1320052	Clamp, Hose	1	
-3	0200417	Arm Weldment (Mid Inboard)	1	
-4	0200418	Arm Weldment (Top Inboard)	1	
	0200420	Arm Weldment (Bottom Outboard)	1	
	0961481	Bushing, Superoilite (8 Per Arm)	8	
-5	0200421	Arm Weldment (Mid Outboard)	2	
	0961481	Bushing, Superoilite (6 Per Arm)	12	
-6	0200422	Arm Weldment (Top Outboard)	1	
	0961481	Bushing, Superoilite (8 Per Arm)	8	
-7	3421784	Pin, Pivot (Bottom Rear)	1	
-8	3421781	Pin, Pivot (Mid Front, Mid Rear and Top Rear)	3	
-9	Not Used			
-10	3421783	Pin, Pivot (Bottom Front)	1	
-11	3421785	Pin, Pivot (Top Rear and Top Front)	2	
-12	3421786	Pin, Pivot (Top Center and Bottom Center)	4	
-13	3421795	Pin, Pivot (Mid Center)	2	
-14	Not Used			
-15	Not Used			
-16	Not Used			
-17				
-18	3340601	Lift Cylinder Sub-Assembly (See Section 11-5 for Breakdown)	1	
-19	Not Used	Pad, Sliding Block	8	
-20	1440224			
-21	0641522	Collar, Pivot Pin	14	
-22	4761500	Bolt 5/16"-18NC x 2 3/4"	46	
-23	3311501	Lockwasher 5/16"	16	
-24	4751500	Nut 5/16"-18NC	38	
-25	4711500	Flatwasher 5/16"	24	
-26	3311505	Flatwasher 5/16" Narrow	17	
-27	4300038	Locknut 5/16"-18NC	16	
-28	1320061	Stud (Welded on Part)	8	
-29	Not Used	Clamp	9	
-30	3421790			
-31	2540002	Pin, Attach (Lift Cylinder Rod)	1	
-32	2820025	Grommet	1 ft./3m	
-33	4740155	Guard, Loom	7 ft./2.2m	
-34	Not Used	Washer, Thrust	1	
-35	Not Used			
-36	3311505	Locknut 5/16"-18NC	23	

**SECTION 11-3 SIZZOR ARMS  
CM2033/CM2046/CM2546/CM2558**

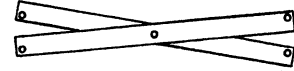

**SECTION 11-3 SIZZOR ARMS**

FIGURE & ITEM NO	PART NUMBER	DESCRIPTION	QTY.	REV.
11-3-1		<b>SIZZOR ARMS INSTALLATION - CM2033 AND CM2046 (CONTINUED)</b>	Ref.	
	0251105	<b>SIZZOR ARMS INSTALLATION - PRIOR TO AUGUST 1992 (VARIABLE PARTS)</b>	Ref.	K
-51	3421782	Pin, Pivot (Bottom Front)	1	
-52	4843090	Safety Prop Weldment	1	
-53	Not Used			
-54	Not Used			
-55	Not Used			
-56	Not Used			
-57	Not Used			
-58	Not Used			
-59	Not Used			
-60	Not Used			
	0252696	<b>SIZZOR ARMS INSTALLATION - AUGUST 1992 TO PRESENT (VARIABLE PARTS)</b>	Ref.	E
-51	3421781	Pin, Pivot (Bottom Front)	1	
-52	4844051	Safety Prop Weldment	1	
-53	3841155	Rod	1	
-54	1360112	Clevis	1	
-55	3430406	Pin, Clevis	1	
-56	3450203	Pin, Cotter 1/16" x 3/4"	1	
-57	3321402	Nut, Jam 1/4"-28NF	1	
-58	0641424	Bolt 1/4"-20NC x 3"	1	
-59	4761400	Lockwasher 1/4"	2	
-60	3311405	Locknut 1/4"-20NC	2	
		<b>SIZZOR ARMS INSTALLATION (PRIOR TO MARCH 1993) (VARIABLE PARTS)</b>	Ref.	
-75	3421789	Pin, Attach (Lift Cylinder Barrel)	1	
-76	3534472	Plate, Retainer	2	
-77	Not Required			
-78	0641506	Bolt 5/16"-18NC x 3/4"	4	
		<b>SIZZOR ARMS INSTALLATION (MARCH 1993 TO PRESENT) (VARIABLE PARTS)</b>	Ref.	
-75	3422215	Pin, Attach (Lift Cylinder Barrel)	1	
-76	Not Required			
-77	3841143	Pin, Keeper	1	
-78	0641509	Bolt 5/16"-18NC x 1 1/8"	1	



**SECTION 11-3 SIZZOR ARMS  
CM2033/CM2046/CM2546/CM2558**

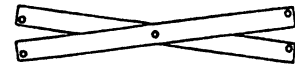
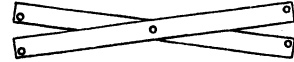

FIGURE & ITEM NO	PART NUMBER	DESCRIPTION	QTY.	REV.
11-3-1		<b>SIZZOR ARMS INSTALLATION - CM2033 AND CM2046 (CONTINUED)</b>	Ref.	
	0252586	<b>ARM PADS INSTALLATION</b>	Ref.	—
—101	3340645	Pad	16	
	0251684	<b>SAFETY PROP LATCH INSTALLATION - MACHINES BUILT PRIOR TO AUGUST 1992</b>	Ref.	—
—201	4843859	Latch	1	
—202	0641518	Bolt 5/16"-18NC x 2 1/4" (Welded on Part)	1	
—203	3311502	Nut, Jam 5/16"-18NC	1	
—204	3311505	Locknut 5/16"-18NC	1	
—205	0641512	----- Bolt 5/16"-18NC x 1 1/2" (Welded on Part)	1	

**SECTION 11-3 SIZZOR ARMS**

# SECTION 11-3 SIZZOR ARMS CM2033/CM2046/CM2546/CM2558

FIGURE 11-3-2. SIZZOR ARMS INSTALLATION -  
CM2546 AND CM2558.



SECTION 11-3 SIZZOR ARMS

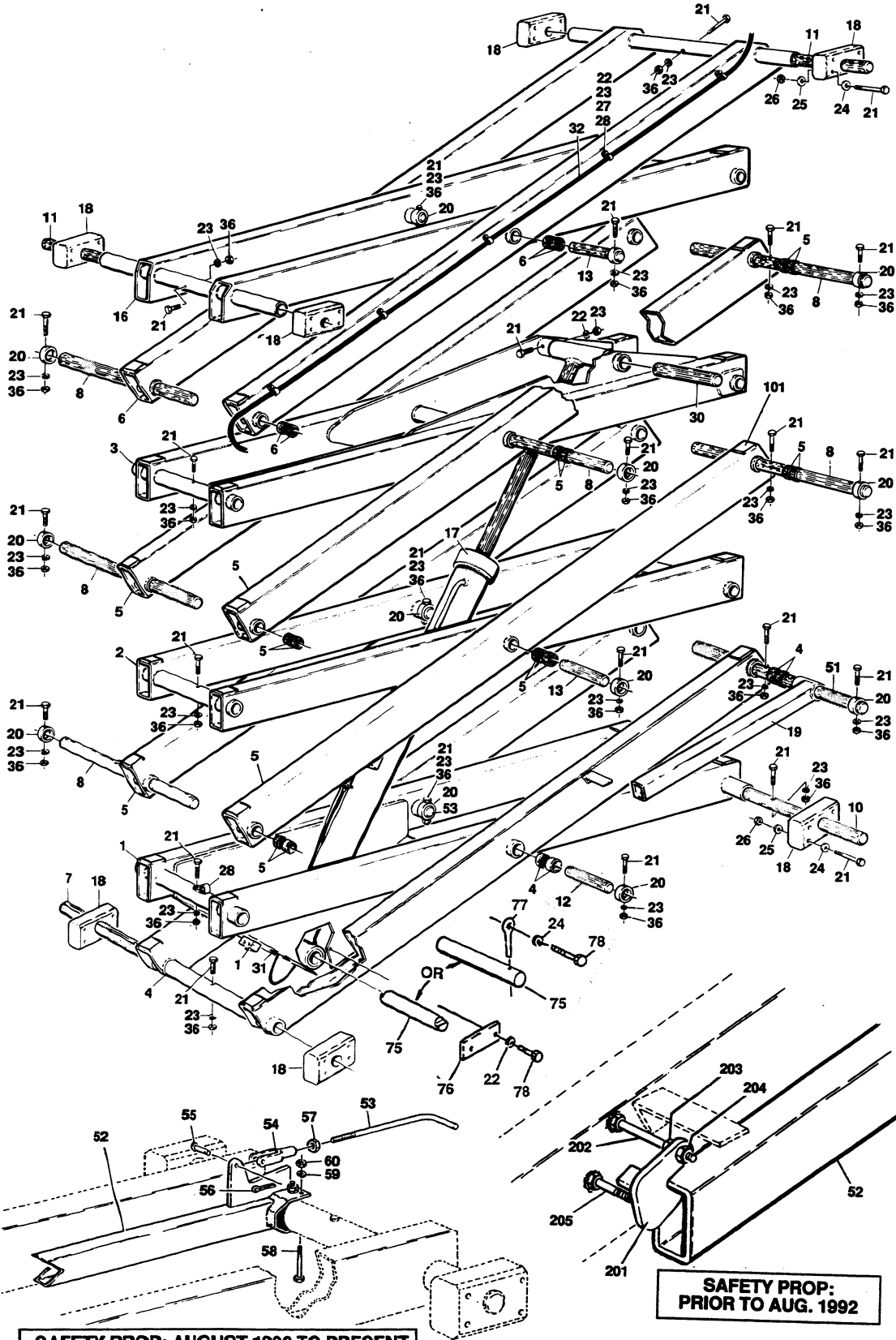

SAFETY PROP: AUGUST 1992 TO PRESENT

SAFETY PROP:  
PRIOR TO AUG. 1992

**SECTION 11-3 SIZZOR ARMS**  
**CM2033/CM2046/CM25426/CM2558**

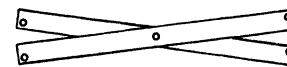

FIGURE & ITEM NO	PART NUMBER	DESCRIPTION	QTY.	REV.
11-3-2		<b>SIZZOR ARMS INSTALLATION - CM2546 AND CM2558.</b>	Ref.	
		<b>SIZZOR ARMS INSTALLATION (STANDARD PARTS)</b>	Ref.	
	2901376	Arms Kit	1	—
—1	0200416	Arm Weldment (Bottom Inboard)(Prior to March 1993)	1	
	0200508	Arm Weldment (Bottom Inboard)(March 1993 to Present)	1	
	1320052	Clamp, Hose	1	
—2	0200417	Arm Weldment (Lower Mid Inboard)	1	
—3	0200424	Arm Weldment (Upper Mid Inboard)	1	
—4	0200420	Arm Weldment (Bottom Outboard)	1	
	0961481	Bushing, Superoilite (8 Per Arm)	8	
—5	0200421	Arm Weldment (Upper and Lower Mid Outboard)	4	
	0961481	Bushing, Superoilite (6 Per Arm)	24	
—6	0200422	Arm Weldment (Top Outboard)	1	
	0961481	Bushing, Superoilite (8 Per Arm)	8	
—7	3421784	Pin, Pivot (Bottom Rear)	1	
—8	3421784	Pin, Pivot (Mid Front, Mid Rear, Upper Mid Center, 6 and Top Rear)		
—9	Not Used			
—10	3421783	Pin, Pivot (Bottom Front)	1	
—11	3421785	Pin, Pivot (Top Rear and Top Front)	2	
—12	3421786	Pin, Pivot (Bottom Center)	2	
—13	3421795	Pin, Pivot (Top Center and Lower Mid Center)	4	
—14	Not Used			
—15	Not Used			
—16	0200423	Arm Weldment (Top Inboard)(Part of Arm Kit)	1	
—17		Lift Cylinder Sub-Assembly (See Section 11-5 for Breakdown)	1	
—18	3340601	Pad, Sliding Block	8	
—19	4843090	Safety Prop Weldment	1	
—20	1440224	Collar, Pivot Pin	20	
—21	0641522	Bolt 5/16"-18NC x 2 3/4"	55	
—22	4761500	Lockwasher 5/16"	14	
—23	3311501	Nut 5/16"-18NC	39	
—24	4751500	Flatwasher 5/16"	24	
—25	4711500	Flatwasher 5/16" Narrow	17	
—26	3311505	Locknut 5/16"-18NC	16	
—27	4300038	Stud (Welded on Part)	5	
—28	1320061	Clamp	6	
—29	Not Used			
—30	3421790	Pin, Attach (Lift Cylinder Rod)	1	
—31	2540002	Grommet	1 ft./3m	
—32	2820025	Guard, Loom	9 ft./2.8m	
—33	4740155	Washer, Thrust	1	
—34	Not Used			
—35	Not Used			
—36	3311505	Locknut 5/16"-18NC	33	

**SECTION 11-3 SIZZOR ARMS**



**SECTION 11-3 SIZZOR ARMS  
CM2033/CM2046/CM25426/CM2558**

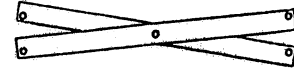
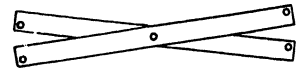

FIGURE & ITEM NO	PART NUMBER	DESCRIPTION	QTY.	REV.
11-3-2		<b>SIZZOR ARMS INSTALLATION - PRIOR TO AUGUST 1992 (VARIABLE PARTS) (CONTINUED)</b>	Ref.	
	0251106	<b>SIZZOR ARMS INSTALLATION - PRIOR TO AUGUST 1992 (VARIABLE PARTS)</b>	Ref.	K
-51	3421782	Pin, Pivot (Bottom Front)	1	
-52	4843090	Safety Prop Weldment	1	
-53 to -60	Not Used			
	0252697	<b>SIZZOR ARMS INSTALLATION - AUGUST 1992 TO PRESENT (VARIABLE PARTS)</b>	Ref.	E
-51	3421781	Pin, Pivot (Bottom Front)	1	
-52	4844051	Safety Prop Weldment	1	
-53	3841155	Rod	1	
-54	1360112	Clevis	1	
-55	3430406	Pin, Clevis	1	
-56	3450203	Pin, Cotter 1/16" x 3/4"	1	
-57	3321402	Nut, Jam 1/4" - 28NF	1	
-58	0641424	Bolt 1/4"-20NC x 3"	2	
-59	4761400	Lockwasher 1/4"	2	
-60	3311405	Locknut 1/4"-20NC	2	
		<b>SIZZOR ARMS INSTALLATION (PRIOR TO MARCH 1993) (VARIABLE PARTS)</b>	Ref.	
-75	3421789	Pin, Attach (Lift Cylinder Barrel)	1	
-76	3534472	Plate, Retainer	2	
-77	Not Required			
-78	0641506	Bolt 5/16"-18NC x 3/4"	4	
		<b>SIZZOR ARMS INSTALLATION (MARCH 1993 TO PRESENT) (VARIABLE PARTS)</b>	Ref.	
-75	3422215	Pin, Attach (Lift Cylinder Barrel)	1	
-76	Not Required			
-77	3841143	Pin, Keeper	1	
-78	0641509	Bolt 5/16"-18NC x 1 1/8"	1	
	0252587	<b>ARM PADS INSTALLATION</b>	Ref.	—
-101	3340645	Pad	24	
	0251684	<b>SAFETY PROP LATCH INSTALLATION - MACHINES BUILT PRIOR TO AUGUST 1992)</b>	Ref.	—
-201	4843859	Latch	1	
-202	0641518	Bolt 5/16"-18NC x 2 1/4" (Welded on Part)	1	
-203	3311502	Nut, Jam 5/16"-18NC	1	
-204	3311505	Locknut 5/16"-18NC	1	
-205	0641512	Bolt 5/16" - 18NC x 1 1/2" (Welded on Part)	1	

**SECTION 11-3 SIZZOR ARMS**

# SECTION 11-3 SIZZOR ARMS CM2033/CM2046/CM2546/CM2558

FIGURE 11-3-3. ARM GUARDS INSTALLATION (PRIOR TO AUGUST 1992).



SECTION 11-3 SIZZOR ARMS

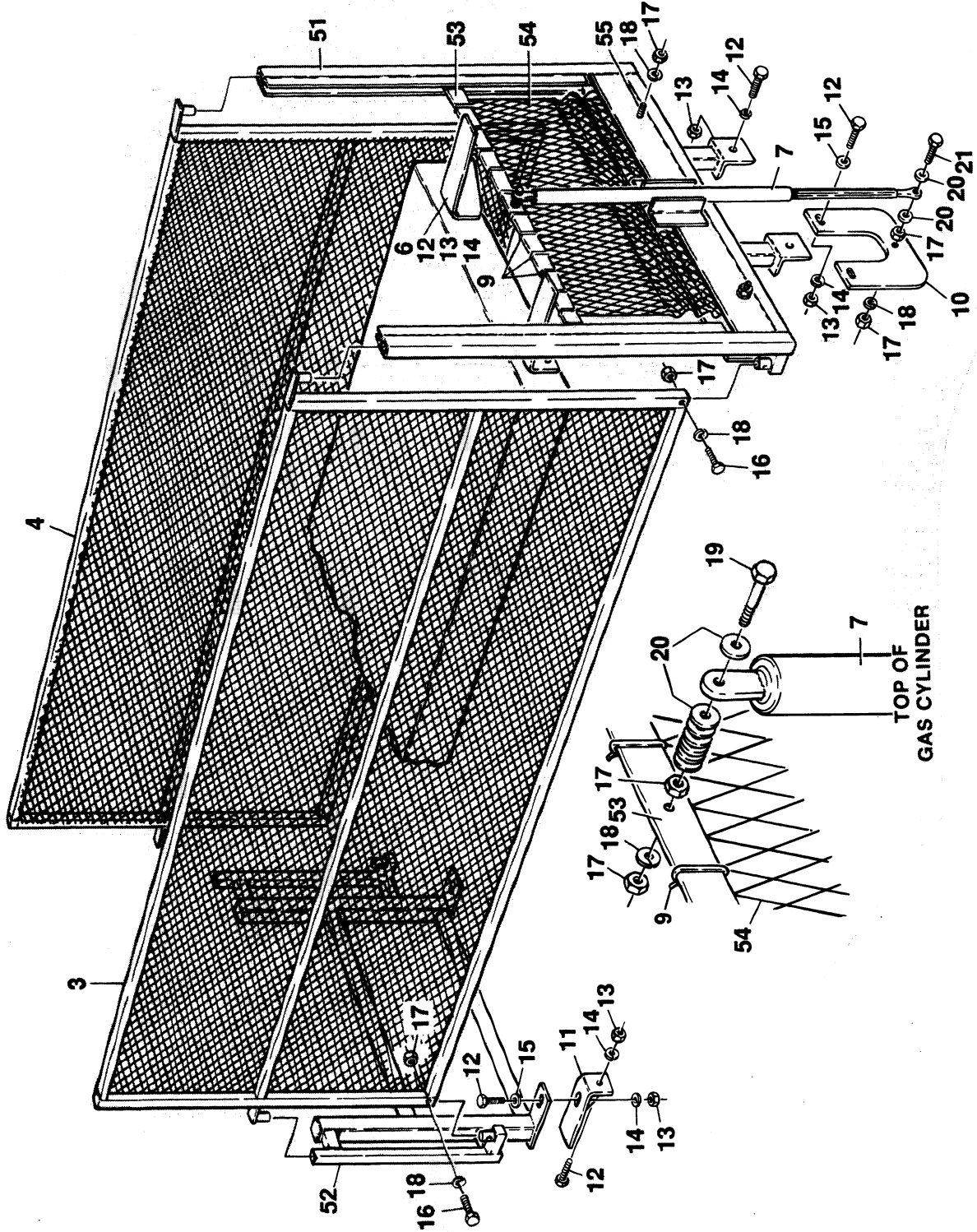

# SECTION 11-3 SIZZOR ARMS CM2033/CM2046/CM2546/CM2558

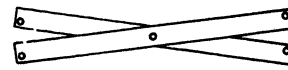
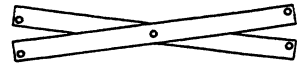

FIGURE & ITEM NO	PART NUMBER	DESCRIPTION	QTY.	REV.
11—3—3		<b>ARM GUARDS INSTALLATION (PRIOR TO AUGUST 1992)</b>	Ref.	—
	1281537	<b>ARM GUARDS INSTALLATION (STANDARD PARTS)</b>	Ref.	—
—1	Not Used			
—2	Not Used			
—3	4843846	Guard Weldment (Right Side)	1	
—4	4843847	Guard Weldment (Left Side)	1	
—5	Not Used			
—6	0901754	Bracket Weldment	2	
—7	4160102	Spring, Gas	1	
—8	Not Used			
—9	4240033	Tie-Strap	12	
—10	3534970	Plate	1	
—11	0901755	Bracket Weldment	2	
—12	0641610	Bolt 3/8"-16NC x 1 1/4"	8	
—13	3311601	Nut 3/8"-16NC	8	
—14	4761600	Lockwasher 3/8"	8	
—15	4751600	Flatwasher 3/8"	8	
—16	0641514	Bolt 5/16"-18NC x 1 3/4"	4	
—17	3311501	Nut 5/16"-18NC	10	
—18	4761500	Lockwasher	8	
—19	0641518	Bolt 5/16"-18NC x 2 1/4"	1	
—20	4711500	Flatwasher 5/16"	11	
—21	0641512	Bolt 5/16"-18NC x 1 1/2"	1	
	0251645	<b>ARM GUARDS INSTALLATION - CM2033 (VARIABLE PARTS)</b>	Ref.	—
—51	4843840	Guard Weldment (Front)	1	
—52	4843843	Guard Weldment (Rear)	1	
	3520071	Cap, Plastic	2	
—53	0361968	Bar	1	
—54	0480066	Belt, Wire Mesh	1	
—55	4843855	Rod Weldment	1	
	0251646	<b>ARM GUARDS INSTALLATION - CM2046 AND CM2546 (VARIABLE PARTS)</b>	Ref.	—
—51	4843841	Guard Weldment (Front)	1	
—52	4843844	Guard Weldment (Rear)	1	
	3520071	Cap, Plastic	2	
—53	0361969	Bar	1	
—54	0480067	Belt, Wire Mesh	1	
—55	4843856	Rod Weldment	1	
	0251647	<b>ARM GUARDS INSTALLATION - CM2558 (VARIABLE PARTS)</b>	Ref.	—
—51	4843842	Guard Weldment (Front)	1	
—52	4843845	Guard Weldment (Rear)	1	
	3520071	Cap, Plastic	2	
—53	0361970	Bar	1	
—54	0480068	Belt, Wire Mesh	1	
—55	4843857	Rod Weldment	1	

SECTION 11 - 3 SIZZOR ARMS

# SECTION 11-3 SIZZOR ARMS CM2033/CM2046/CM2546/CM2558

FIGURE 11-3-4. ARM GUARDS INSTALLATION  
(AUGUST 1992 TO MAY 1994).



SECTION 11-3 SIZZOR ARMS

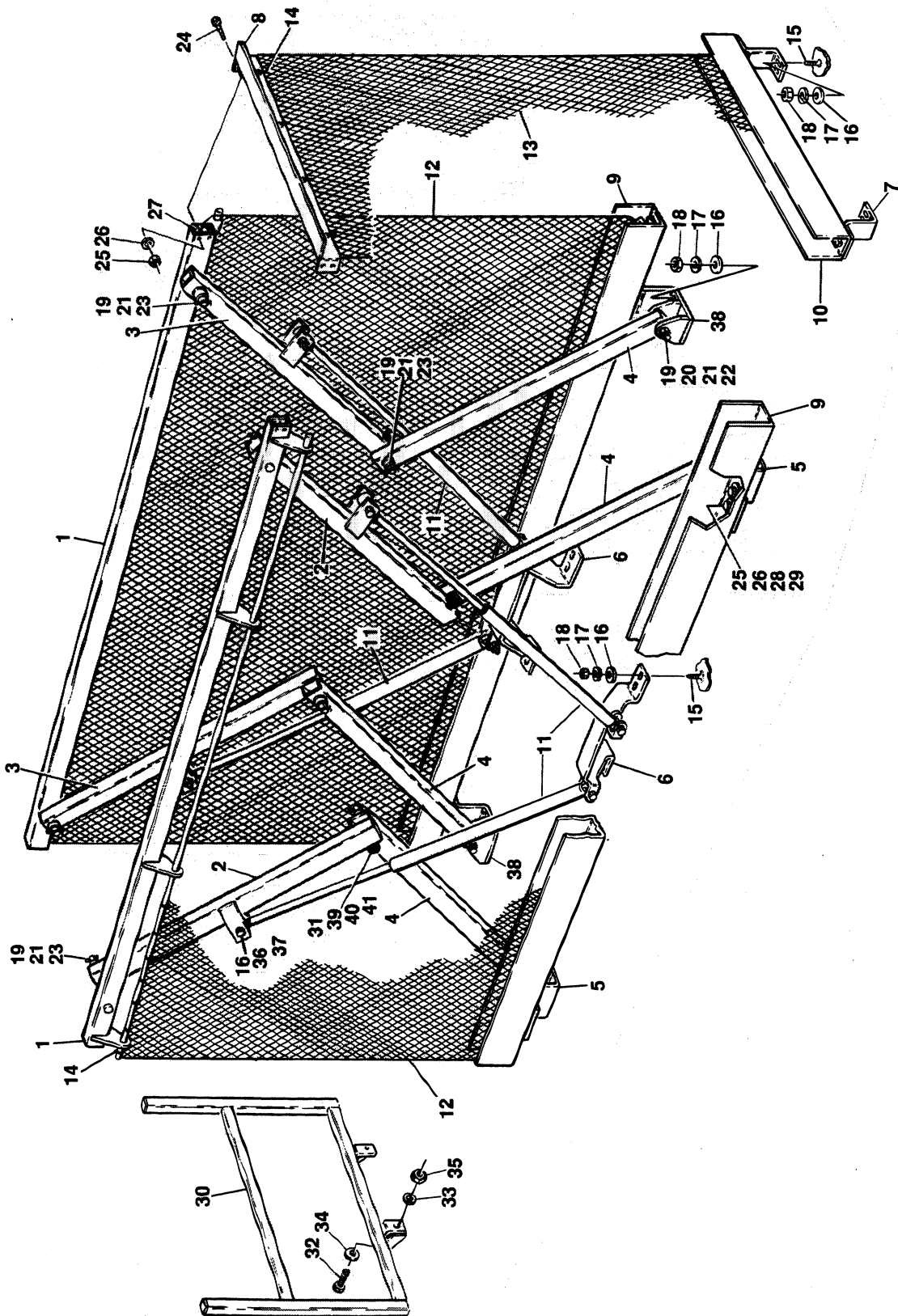



# SECTION 11-3 SIZZOR ARMS CM2033/CM2046/CM2546/CM2558

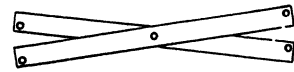

FIGURE & ITEM NO	PART NUMBER	DESCRIPTION	QTY.	REV.
11-3-4	0252401	ARM GUARDS INSTALLATION (AUGUST 1992 TO MAY 1994)	Ref.	E
—1	4844042	Top Frame Tube Weldment	2	
—2	4844039	Tube Weldment - Top Right Side	2	
—3	4844040	Tube Weldment - Top Left Side	2	
—4	4844041	Tube Weldment - Bottom	4	
—5	4844045	Bracket Weldment - Right Side	2	
—6	4844340	Bracket Weldment	2	
—7	0901915	Bracket (Front)	2	
	0901960	Bracket (Rear)	2	
—8	3535707	Plate	1	
	3537316	Stop, Plate (Not Shown)	2	
—9	3535708	Tray, Side	2	
—10	3535709	Tray, Front	2	
—11	4160126	Spring, Gas	4	
—12	0480070	Belt, Wire Mesh - Sides	2	
—13	0480071	Belt, Wire Mesh - Front	2	
—14	4240033	Tie-Strap	76	
—15	4300038	Stud (Welded on Part)	28	
—16	4751500	Flatwasher 5/16"	68	
—17	4761500	Lockwasher 5/16"	28	
—18	3311501	Nut 5/16"-18NC	28	
—19	0961627	Bearing, Flanged	24	
—20	0641820	Bolt 1/2"-13NC x 2 1/2"	4	
—21	4751800	Flatwasher 1/2"	12	
—22	3311805	Locknut 1/2"-13NC	4	
—23	3450404	Pin, Cotter 1/8" x 1"	8	
—24	0641412	Bolt 1/4"-20NC x 1 1/2"	8	
—25	3311401	Nut 1/4"-20NC	32	
—26	4761400	Lockwasher 1/4"	32	
—27	4565559	Spacer, Tube	8	
—28	0641406	Bolt 1/4"-20NC x 3/4"	24	
—29	4751400	Flatwasher 1/4"	40	
—30	4844564	Ladder Weldment	1	
	3520071	Cap, Plastic	2	
—31	0940045	Bumper, Rubber	4	
—32	0641610	Bolt 3/8"-16NC x 1 1/4"	2	
—33	4761600	Lockwasher 3/8"	2	
—34	4751600	Flatwasher 3/8"	2	
—35	3311601	Nut 3/8"-16NC	2	
—36	0641510	Bolt 5/16"-18NC x 1 1/4"	4	
—37	3311505	Locknut 5/16"-18NC	8	
—38	4844091	Bracket Weldment - Left Side	2	
—39	0641410	Bolt 1/4"-20NC x 1 1/4"	4	
—40	4711400	Flatwasher 1/4"	4	
—41	3311405	Locknut 1/4"-20NC	4	
	2901401	Repair Kit - Complete	1	

SECTION 11-3 SIZZOR ARMS



# SECTION 11-3 SIZZOR ARMS CM2033/CM2046/CM2546/CM2558

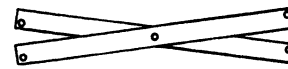
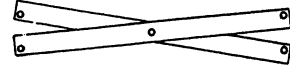

FIGURE & ITEM NO	PART NUMBER	DESCRIPTION	QTY.	REV.
11-3-5		<b>ARM GUARDS INSTALLATION (MAY 1994 TO JUNE 1995)</b>	Ref.	
	0253991	<b>ARM GUARDS INSTALLATION- STANDARD MACHINES</b>	Ref.	C
	0255734	<b>ARM GUARDS INSTALLATION - WITH OUTDOOR PKG</b>	Ref.	—
—1	0901915	Bracket	2	
—2	3535709	Tray, End	2	
—3	3535708	Tray, Side	2	
—4	0901812	Bracket	4	
—5	0480070	Belt, Mesh-Sides	2	
—6	0480071	Belt, Mesh - Ends	2	
—7	4240033	Tie-Strap	70	
—8	4844564	Ladder Weldment	1	
	3520071	Cap, Plastic	2	
—9	0901937	Bracket (Left Side Rear/Right Side Front) (Standard)	2	
	0901937	Bracket (Right Side Front) (Outdoor Package)	1	
	0901891	Bracket (Left Side Rear) (Outdoor Package)	1	
—10	0901958	Bracket (Right Side Rear/Left Side Front) (Standard)	2	
	0901958	Bracket (Left Side Front) (Outdoor Package)	1	
	0901892	Bracket (Right Side Rear) (Outdoor Package)	1	
—11	4844262	Arm Weldment - Top (Right Side Rear/Left Side Front)	2	
—12	4844261	Arm Weldment - Top (Left Side Rear/Right Side Front)	2	
—13	4844259	Arm Weldment - Bottom (Right Side Rear/Left Side Front)	2	
—14	4844260	Arm Weldment - Bottom (Left Side Rear/Right Side Front)	2	
—15	4844411	Channel, Side	2	
—16	4160106	Spring, Gas	4	
—17	0181683	Angle, End	2	
—18	0641610	Bolt 3/8"-16NC x 1 1/4"	4	
—19	Not Used			
—20	4751600	Flatwasher 3/8"	8	
—21	3311605	Locknut 3/8"-16NC	4	
—22	4300038	Stud (Welded on Part)	28	
—23	4751500	Flatwasher 5/16"	40	
—24	4740128	Washer, Bronze	12	
—25	3311505	Locknut 5/16"-18NC	40	
—26	3020010	Never-Seez Lubricant (Not Shown)	A/R	
—27	3311405	Locknut 1/4"-20NC	28	
—28	0641406	Bolt 1/4"-20NC x 3/4"	32	
—29	4751400	Flatwasher 1/4"	40	
—30	3450404	Pin, Cotter 1/8" x 1"	4	
—31	4751800	Flatwasher 1/2"	4	
—32	3430810	Pin, Clevis 1/2" x 1 1/4"	4	
—33	3311805	Locknut 1/2"-13NC	8	
—34	3311802	Nut, Jam 1/2"-13NC	4	
—35	0641814	Bolt 1/2"-13NC x 1 3/4"	4	
—36	0641608	Bolt 3/8"-16NC x 1"	4	
—37	3311601	Nut 3/8"-16NC	4	
—38	0901960	Bracket	2	
—39	3537317	Plate, Stop	4	
—40	1271249	Channel, Stop	4	
	2901401	Repair Kit - Complete	1	—

**SECTION 11-3 SIZZOR ARMS**

# SECTION 11-3 SIZZOR ARMS CM2033/CM2046/CM2546/CM2558

FIGURE 11-3-6. ARM GUARDS INSTALLATION  
(JUNE 1995 TO PRESENT).



SECTION 11-3 SIZZOR ARMS

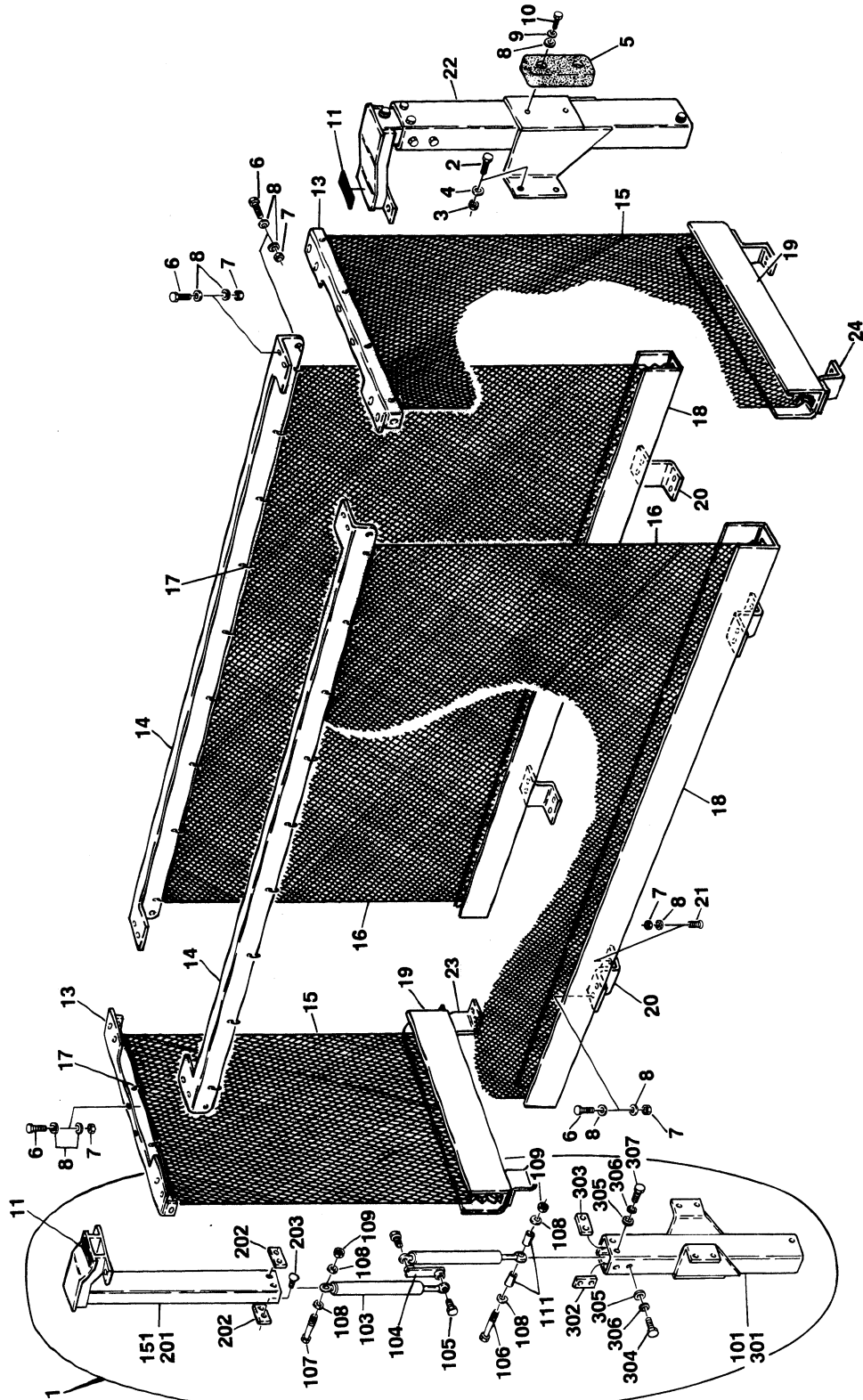

# SECTION 11-3 SIZZOR ARMS CM2033/CM2046/CM2546/CM2558

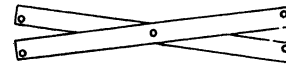
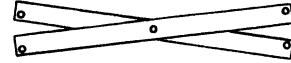

FIGURE & ITEM NO	PART NUMBER	DESCRIPTION	QTY.	REV.
11-3-6		<b>ARM GUARDS INSTALLATION (JUNE 1995 TO PRESENT)</b>	Ref.	
	0255573	<b>ARM GUARDS INSTALLATION</b>	Ref.	A
—1	0255594	Telescopic Tube Assembly - Rear (See Items 101-151 for Breakdown)	1	
—2	0641608	Bolt 3/8"-16NC x 1"	8	
—3	3311605	Locknut 3/8"-16NC	8	
—4	4751600	Flatwasher 3/8"	8	
—5	0940042	Bumper	1	
—6	0641406	Bolt 1/4"-20NC x 3/4"	28	
—7	3311405	Locknut 1/4"-20NC	52	
—8	4751400	Flatwasher 1/4"	56	
—9	0641410	Bolt 1/4"-20NC x 1 1/4"	2	
—10	4761400	Lockwasher 1/4"	2	
—11	4420055	Tape, UHMW	6in/15cm	
—12	Not Used			
—13	0181799	Angle, End	2	
—14	0181800	Angle, Side	2	
—15	0480070	Belt, Wire Mesh - End	2	
—16	0480071	Belt, Wire Mesh - Side	2	
—17	4240033	Tie-Strap	70	
—18	3535708	Tray, Side	2	
—19	3535709	Tray, End	2	
—20	0901812	Bracket - Side	4	
—21	4300032	Stud (Welded on Part)	24	
—22	0255575	Telescopic Tube Assembly - Front (See Items 101-151 for Breakdown)	1	
—23	0901960	Bracket - Rear	2	
—24	0901915	Bracket - Front	2	
		<b>TELESCOPIC TUBE ASSEMBLIES (STANDARD PARTS)</b>	Ref.	
—101	0255595	Outer Tube Assembly (See Items 301-306 for Breakdown)	1	
—102	Not Used			
—103	4160136	Spring, Gas	2	
—104	4845013	Link	1	
—105	0641508	Bolt 5/16"-18NC x 1"	2	
—106	0641524	Bolt 5/16"-18NC x 3"	1	
—107	0641516	Bolt 5/16"-18NC x 2"	1	
—108	4751500	Flatwasher 5/16"	4	
—109	3311505	Locknut 5/16"-18NC	2	
—110	0100011	Loctite (Not Shown)	A/R	
—111	0961378	Bushing	2	
	0255594	<b>TELESCOPIC TUBE ASSEMBLY - REAR (VARIABLE PARTS)</b>	Ref.	B
—151	0256165	Inner Tube Assembly (See Items 201-203 for Breakdown)	1	

SECTION 11-3 SIZZOR ARMS

# SECTION 11-3 SIZZOR ARMS CM2033/CM2046/CM2546/CM2558



**SECTION 11-3 SIZZOR ARMS**

FIGURE & ITEM NO	PART NUMBER	DESCRIPTION	QTY.	REV.
11—3—6		<b>ARM GUARDS INSTALLATION (JUNE 1995 TO PRESENT)</b>	Ref.	
	0255575	<b>TELESCOPIC TUBE ASSEMBLIES - FRONT (VARIABLE PARTS)</b>	Ref.	A
—151	0255578	Inner Tube Assembly (See Items 201-203 for Breakdown)	1	
	0256165	<b>INNER TUBE ASSEMBLY - REAR</b>	Ref.	—
—201	4845275	Inner Tube Weldment - Rear	1	
—202	3340780	Pad, Wear	2	
—203	3900213	Screw, Button Head	4	
	0255578	<b>INNER TUBE ASSEMBLY - FRONT</b>	Ref.	A
—201	4845014	Inner Tube Weldment - Rear	1	
—202	3340780	Pad, Wear	2	
—203	3900213	Screw, Button Head	4	
	0255595	<b>OUTER TUBE ASSEMBLY</b>	Ref.	—
—301	4845025	Outer Tube Weldment	1	
—302	3340781	Pad, Wear	2	
—303	3340780	Pad, Wear	2	
—304	0641604	Bolt 3/8"-16NC x 1/2"	8	
—305	4751600	Flatwasher 3/8"	8	
—306	4761600	Lockwasher 3/8"	8	

# SECTION 11-4 PLATFORM CM2033/CM2046/CM2546/CM2558

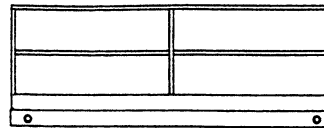

## TABLE OF CONTENTS

FIGURE NO.	DESCRIPTION	PAGE NO.
11-4-1	Standard Handrails and Accessories Installation .....	11-4-2
11-4-2	Optional Fold-Down Handrail Installations .....	11-4-8
11-4-3	Optional Extendable Deck Installation with Standard Handrails .....	11-4-12
11-4-4	Optional Extendable Deck Installation with Fold-Down Handrails .....	11-4-16
11-4-5	Steel Platform Console Box Assembly .....	11-4-20
11-4-6	Molded Platform Console Box Assembly .....	11-4-24

SECTION 11 - 4 PLATFORM

# SECTION 11-4 PLATFORM CM2033/CM2046/CM2546/CM2558

FIGURE 11-4-1. STANDARD HANDRAILS AND ACCESSORIES  
INSTALLATION.

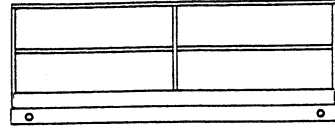

SECTION 11-4 PLATFORM

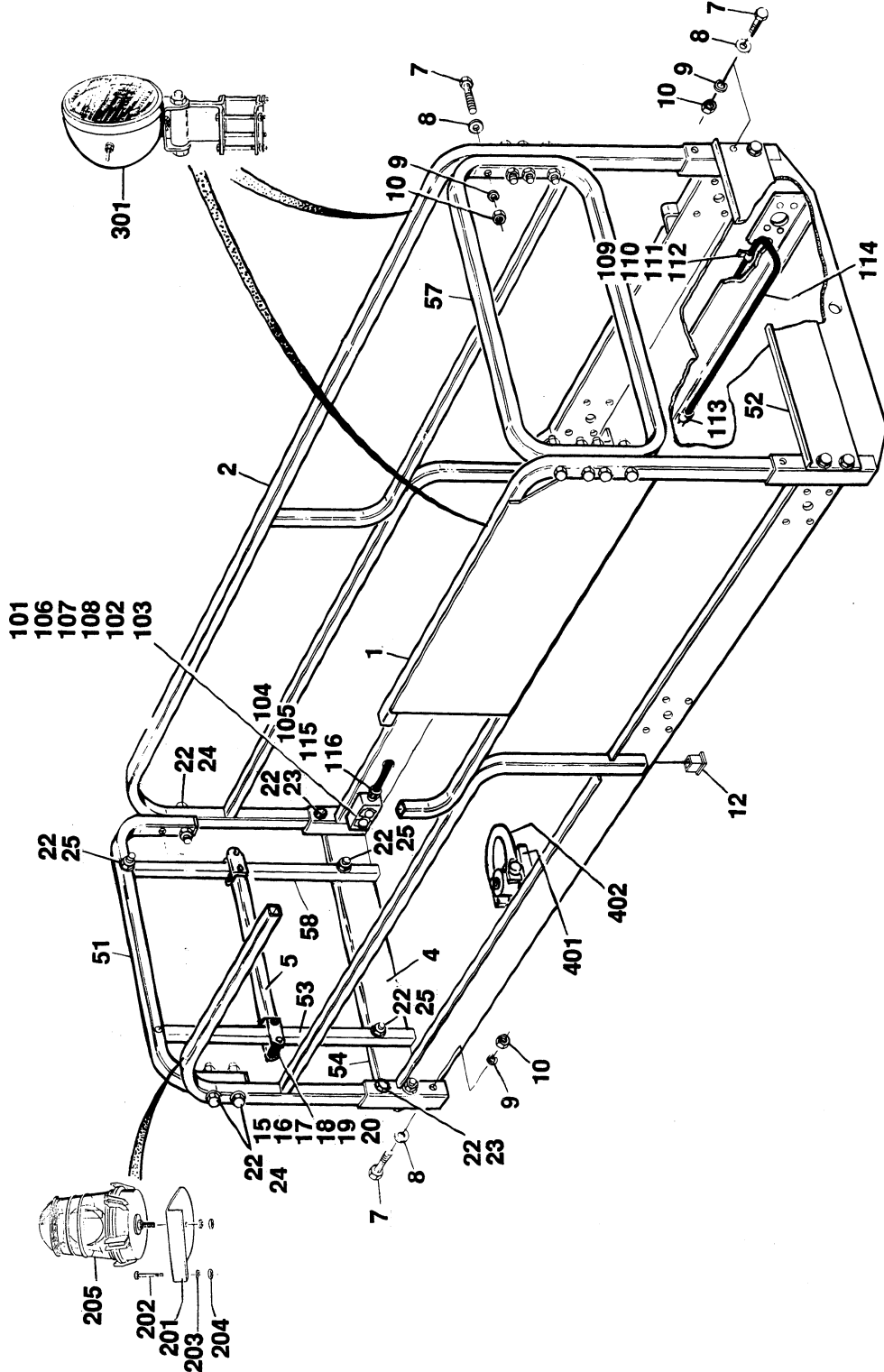



# SECTION 11-4 PLATFORM CM2033/CM2046/CM2546/CM2558

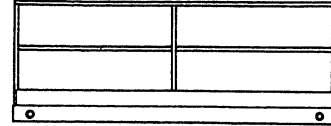
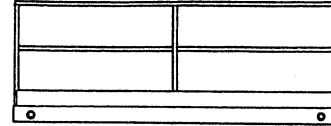

FIGURE & ITEM NO	PART NUMBER	DESCRIPTION	QTY.	REV.
11-4-1		<b>STANDARD HANDRAILS AND ACCESSORIES INSTALLATION</b>	Ref.	
		<b>PLATFORM OPTIONS:</b>		
	3510264	Platform - All CM2033 Built Prior to April 1992	1	
	3510369	Platform - CM2033 With Fixed Deck Built April 1992 to Present	1	
	3510367	Platform - CM2033 With Extendable Deck Built April 1992 to Present	1	
	3510313	Platform - All CM2046 and CM2546 Built Prior to April 1992	1	
	3510370	Platform - CM2046 and CM2546 With Fixed Deck Built April 1992 to Present	1	
	3510368	Platform - CM2046 and CM2546 With Extendable Deck Built April 1992 to Present	1	
	3510314	Platform - All CM2558 Built Prior to April 1993	1	
	3510416	Platform - CM2558 With Fixed Deck Built April 1993 to Present	1	
	3510417	Platform - CM2558 With Extendable Deck Built April 1993 to Present	1	
		<b>STANDARD HANDRAILS INSTALLATION (STANDARD PARTS)</b>	Ref.	
-1	3640727	Handrail - Right Side	1	
-2	3640728	Handrail - Left Side	1	
-3	Not Used			
-4	3533370	Kickplate - Rear	1	
-5	3640614	Drop - Gate	1	
-6	Not Used			
-7	0641424	Bolt 1/4"-20NC x 3"	A/R	
-8	4711400	Flatwasher 1/4" Narrow	A/R	
-9	4761400	Lockwasher 1/4"	A/R	
-10	3311401	Nut 1/4"-20NC	A/R	
-11	Not Used			
-12	3520072	Plug, Cap	6	
-13	Not Used			
-14	Not Used			
-15	0961833	Bushing	4	
-16	4420055	Tape	A/R	
-17	3911034	Screw, Machine #10-24NC x 2 1/4"	4	
-18	4751000	Flatwasher #10	4	
-19	4761000	Lockwasher #10 (When Equipped)	4	
-20	3311005	Locknut #10-24NC	4	
-21	Not Used			
-22	3900184	Screw, Buttonhead #10-24NC x 5/8"	12	
-23	3300374	Nut, Joint Connector 1 7/8"	4	
-24	3300375	Nut, Joint Connector 2 3/8"	4	
-25	3300373	Nut, Joint Connector 1 1/4"	4	

SECTION 11-4 PLATFORM

# SECTION 11-4 PLATFORM CM2033/CM2046/CM2546/CM2558



SECTION 11-4 PLATFORM

FIGURE & ITEM NO	PART NUMBER	DESCRIPTION	QTY.	REV.
11-4-1		<b>STANDARD HANDRAILS AND ACCESSORIES INSTALLATION (CONTINUED)</b>	Ref.	
	0251600	<b>STANDARD HANDRAILS INSTALLATION (CM2033 WITH FIXED DECK - NOT SHOWN) (VARIABLE PARTS)</b>	Ref.	E
-51	4565201	Tube, Handrail - Rear	1	
-52	3534682	Kickplate - Front	1	
-53	Not Required			
-54	Not Required			
-55	Not Used			
-56	Not Used			
-57	3640796	Tube, Handrail - Front	1	
-58	Not Required			
	0251601	<b>STANDARD HANDRAILS INSTALLATION (CM2033 WITH EXTENDABLE DECK - NOT SHOWN) (VARIABLE PARTS)</b>	Ref.	D
-51	4565201	Tube, Handrail - Rear	1	
-52	Not Required			
-53	Not Required			
-54	Not Required			
-55	Not Used			
-56	Not Used			
-57	Not Required			
-58	Not Required			
	0251602	<b>STANDARD HANDRAIL INSTALLATION (CM2046 AND CM2546 WITH FIXED DECK) (VARIABLE PARTS)</b>	Ref.	E
-51	4565202	Tube, Handrail - Rear	1	
-52	3534740	Kickplate - Front	1	
-53	3640731	Tube, Handrail - Rear Vertical (Right Side)	1	
-54	3534742	Kickplate - Rear	2	
-55	Not Used			
-56	Not Used			
-57	4564731	Tube, Handrail - Front	2	
-58	3640730	Tube, Handrail - Rear Vertical (Left Side)	1	
	0251603	<b>STANDARD HANDRAIL INSTALLATION (CM2046 AND CM2546 WITH EXTENDABLE DECK) (VARIABLE PARTS)</b>	Ref.	E
-51	4565202	Tube, Handrail - Rear	1	
-52	Not Required			
-53	3640731	Tube, Handrail - Rear Vertical (Right Side)	1	
-54	3534742	Kickplate - Rear	2	
-55	Not Used			
-56	Not Used			
-57	Not Required			
-58	3640730	Tube, Handrail - Rear Vertical (Left Side)	1	

# SECTION 11-4 PLATFORM CM2033/CM2046/CM2546/CM2558

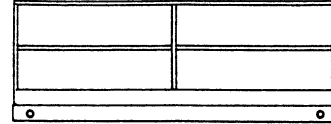

FIGURE & ITEM NO	PART NUMBER	DESCRIPTION	QTY.	REV.
11-4-1		<b>STANDARD HANDRAILS AND ACCESSORIES INSTALLATION (CONTINUED)</b>	Ref.	
	0251604	<b>STANDARD HANDRAIL INSTALLATION (CM2558 WITH FIXED DECK) (VARIABLE PARTS)</b>	Ref.	E
-51	4565203	Tube, Handrail - Rear	1	
-52	3534741	Kickplate - Front	1	
-53	3640731	Tube, Handrail - Rear Vertical (Right Side)	1	
-54	3534743	Kickplate - Rear	2	
-55	Not Used			
-56	Not Used			
-57	4564732	Tube, Handrail	2	
-58	3640730	Tube, Handrail - Rear Vertical (Left Side)	1	
	0251605	<b>STANDARD HANDRAIL INSTALLATION (CM2558 WITH EXTENDABLE DECK) (VARIABLE PARTS)</b>	Ref.	E
-51	4565203	Tube, Handrail - Rear	1	
-52	Not Required			
-53	3640731	Tube, Handrail - Rear Vertical (Right Side)	1	
-54	3534743	Kickplate - Rear	2	
-55	Not Used			
-56	Not Used			
-57	Not Required			
-58	3640730	Tube, Handrail - Rear Vertical (Left Side)	1	
	0251782	<b>OPTIONAL RECEPTACLE INSTALLATION - 110 VOLT (CM2033)</b>	Ref.	D
	0251783	<b>OPTIONAL RECEPTACLE INSTALLATION - 110 VOLT (CM2046)</b>	Ref.	D
	0251784	<b>OPTIONAL RECEPTACLE INSTALLATION - 110 VOLT (CM2546/CM2558)</b>	Ref.	D
-101	Supply Locally	Box, Electrical	1	
-102	Supply Locally	Receptacle	1	
-103	Supply Locally	Shield, Cover	1	
-104	4460051	Connector, Strain Relief	1	
-105	Supply Locally	Bushing, Reducer	1	
-106	0721004	Bolt #10-24NC x 1/2"	4	
-107	4751000	Flatwasher #10	4	
-108	4761000	Lockwasher #10	4	
-109	1320061	Clamp	10	
-110	4761400	Lockwasher 1/4"	8	
-111	3311401	Nut 1/4"-20NC	8	
-112	4300032	Stud (Welded on Part)	8	
-113	Supply Locally	Plug	1	
-114	1060308	Cable, Electrical - 12/3 CM2033 and CM2046 CM2546 and CM2558	A/R 42 ft./13m 45 ft./14m	
-115	1700598	Decal - Wire Marker (Ground)	2	
-116	1700599	Decal - Wire Marker (Neutral)	2	

SECTION 11-4 PLATFORM



# SECTION 11-4 PLATFORM CM2033/CM2046/CM2546/CM2558

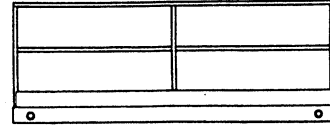

FIGURE & ITEM NO	PART NUMBER	DESCRIPTION	QTY.	REV.
11-4-1		<b>STANDARD HANDRAILS AND ACCESSORIES INSTALLATION (CONTINUED)</b>	Ref.	
	0254378	<b>OPTIONAL RECEPTACLE INSTALLATION - 220 VOLT (CM2033/2046)</b>	Ref.	A
	0254379	<b>OPTIONAL RECEPTACLE INSTALLATION - 220 VOLT (CM2546/2558)</b>	Ref.	A
-101	086038	Box, Electrical	1	
-102	Supply Locally	Receptacle	1	
-103	4060092	Shield, Cover	1	
-104	4460049	Connector, Strain Relief	1	
-105	0960407	Bushing, Reducer	1	
-106	0721004	Bolt #10-24NC x 1/2"	4	
-107	4751000	Flatwasher #10	4	
-108	4761000	Lockwasher #10	4	
-109	1320061	Clamp	10	
-110	4761400	Lockwasher 1/4"	8	
-111	3311401	Nut 1/4"-20NC	8	
-112	4300032	Stud (Welded on Part)	8	
-113	Supply Locally	Plug	1	
-114	1060308	Cable, Electrical - 12/3 CM2033 and CM2046 CM2546 and CM2558	A/R 42 ft./13m 45 ft./14m	
-115	1700598	Decal - Wire Marker (Ground)	2	
-116	1700599	Decal - Wire Marker (Neutral)	2	
	0253476	<b>OPTIONAL ROTATING BEACON LIGHT INSTALLATION (CM2033/2046)</b>	Ref.	—
	0253478	<b>OPTIONAL ROTATING BEACON LIGHT INSTALLATION (CM2546/2558)</b>	Ref.	—
-201	0901546	Bracket	1	
-202	0641414	Bolt 1/4"-20NC x 1 3/4"	2	
-203	4751400	Flatwasher 1/4"	2	
-204	3311505	Locknut 1/4"-20NC	2	
-205	2920087	Light, Beacon - Standard	1	
	0253504	<b>OPTIONAL WORKLIGHTS INSTALLATION (CM2033/2046)</b>	Ref.	—
	0253506	<b>OPTIONAL WORKLIGHTS INSTALLATION (CM2546/2558)</b>	Ref.	—
-301	2920088	Worklight (Standard Machines Built Prior to August 1992)	2	
	2920093	Worklight (Standard Machines Built August 1992 to Present)	2	
	0253544	<b>OPTIONAL HARNESS ATTACH RINGS INSTALLATION</b>	Ref.	—
-401	3534309	Plate, Ring Attach	2	
-402	3760274	Ring, Lanyard	2	

SECTION 11 - 4 PLATFORM



# SECTION 11-4 PLATFORM CM2033/CM2046/CM2546/CM2558

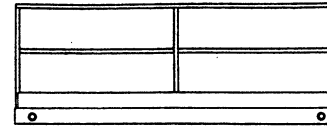

FIGURE & ITEM NO	PART NUMBER	DESCRIPTION	QTY.	REV.
------------------	-------------	-------------	------	------

11-4-2		<b>OPTIONAL FOLD-DOWN HANDRAIL INSTALLATIONS</b>	Ref.	
		<b>FOLD-DOWN HANDRAIL INSTALLATION - ALL DECKS (STANDARD PARTS WHEN EQUIPPED)</b>	Ref.	
-1	3640738	Handrail - Lower Side	2	
-2	Not Used			
-3	Not Used			
-4	3640740	Handrail - Top Side	2	
-5	4565191	Tube - Ends	4	
-6	3640742	Tube - Center (Right Side)	1	
-7	0641424	Bolt 1/4"-20NC x 3"	A/R	
-8	4751400	Flatwasher 1/4"	A/R	
-9	4761400	Lockwasher 1/4"	A/R	
-10	3311401	Nut 1/4"-20NC	A/R	
-11	Not Used			
-12	3520072	Plug, Cap	22	
-13	Not Used			
-14	Not Used			
-15	3430416	Pin, Clevis 1/4" x 2"	16	
-16	4711400	Flatwasher 1/4"	42	
-17	3450203	Pin, Cotter 1/16" x 3/4"	16	
-18	Not Used			
-19	3630614	Drop Gate	1	
-20	Not Used			
-21	Not Used			
-22	1260017	Chain (4 Lengths 7 in./17.8 cm each)	28 in./7m	
-23	3535337	Kickplate - Rear	1	
-24	Not Used			
-25	Not Used			
-26	3421913	Pin, Quick Release	4	
-27	Not Used			
-28	Not Used			
-29	3640753	Tube - Center (Left Side)	1	
-30 to -34	Not Used			
-35	0961833	Bushing	4	
-36	4420055	Tape	A/R	
-37	3911034	Screw, Machine #10-24NC x 2 1/4"	4	
-38	4751000	Flatwasher #10	4	
-39	4761000	Lockwasher #10	4	
-40	3311001	Nut #10-24NC	4	
-41	Not Used			
-42	3900184	Screw, Buttonhead #10-24NC x 5/8"	12	
-43	3300373	Nut, Joint Connector 1 1/4"	6	
-44	3300374	Nut, Joint Connector 1 7/8"	4	
-45	3300375	Nut, Joint Connector 2 3/8"	4	

SECTION 11 - 4 PLATFORM

# SECTION 11-4 PLATFORM

## CM2033/CM2046/CM2546/CM2558

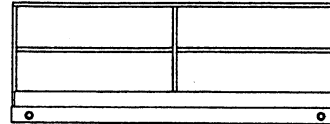

**SECTION 11-4 PLATFORM**

FIGURE & ITEM NO	PART NUMBER	DESCRIPTION	QTY.	REV.
11-4-2		<b>OPTIONAL FOLD-DOWN HANDRAIL INSTALLATIONS</b>	Ref.	
	0251840	<b>FOLD-DOWN HANDRAIL INSTALLATION - CM2033 WITH FIXED DECK (VARIABLE PARTS)</b>	Ref.	D
-51	3534682	Kickplate - Front	1	
-52	4564730	Handrail - Front	2	
-53	3533091	Plate, Mounting - Control Box	1	
-54	Not Required			
-55	Not Required			
-56	Not Used			
-57	Not Required			
-58	Not Required			
-59	Not Required			
-60	4565285	Handrail - Rear	1	
-61	Not Required			
-62	Not Required			
	0251841	<b>FOLD-DOWN HANDRAIL INSTALLATION - CM2033 WITH EXTENDABLE DECK (VARIABLE PARTS)</b>	Ref.	E
-51	Not Required			
-52	Not Required			
-53	Not Required			
-54	Not Required			
-55	Not Required			
-56	Not Used			
-57	Not Required			
-58	Not Required			
-59	Not Required			
-60	4565285	Handrail - Rear	1	
-61	Not Required			
-62	Not Required			
	0251842	<b>FOLD-DOWN HANDRAIL INSTALLATION - CM2046 AND CM2546 WITH FIXED DECK (VARIABLE PARTS)</b>	Ref.	E
-51	3534740	Kickplate - Front	1	
-52	4564731	Handrail - Front	2	
-53	3533091	Plate, Mounting - Control Box	1	
-54	3640743	Handrail - Top Rear Vertical	2	
-55	Not Used			
-56	Not Used			
-57	0641408	Bolt 1/4"-20NC x 1"	4	
-58	3640761	Handrail - Bottom Rear Vertical	2	
-59	3535337	Kickplate - Rear	2	
-60	3640744	Handrail - Rear	1	
-61	4565261	Handrail - Center Rear Vertical	2	
-62	4565598	Tube, Support	1	



# SECTION 11-4 PLATFORM CM2033/CM2046/CM2546/CM2558

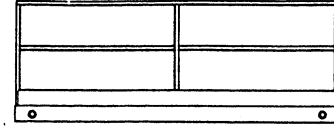
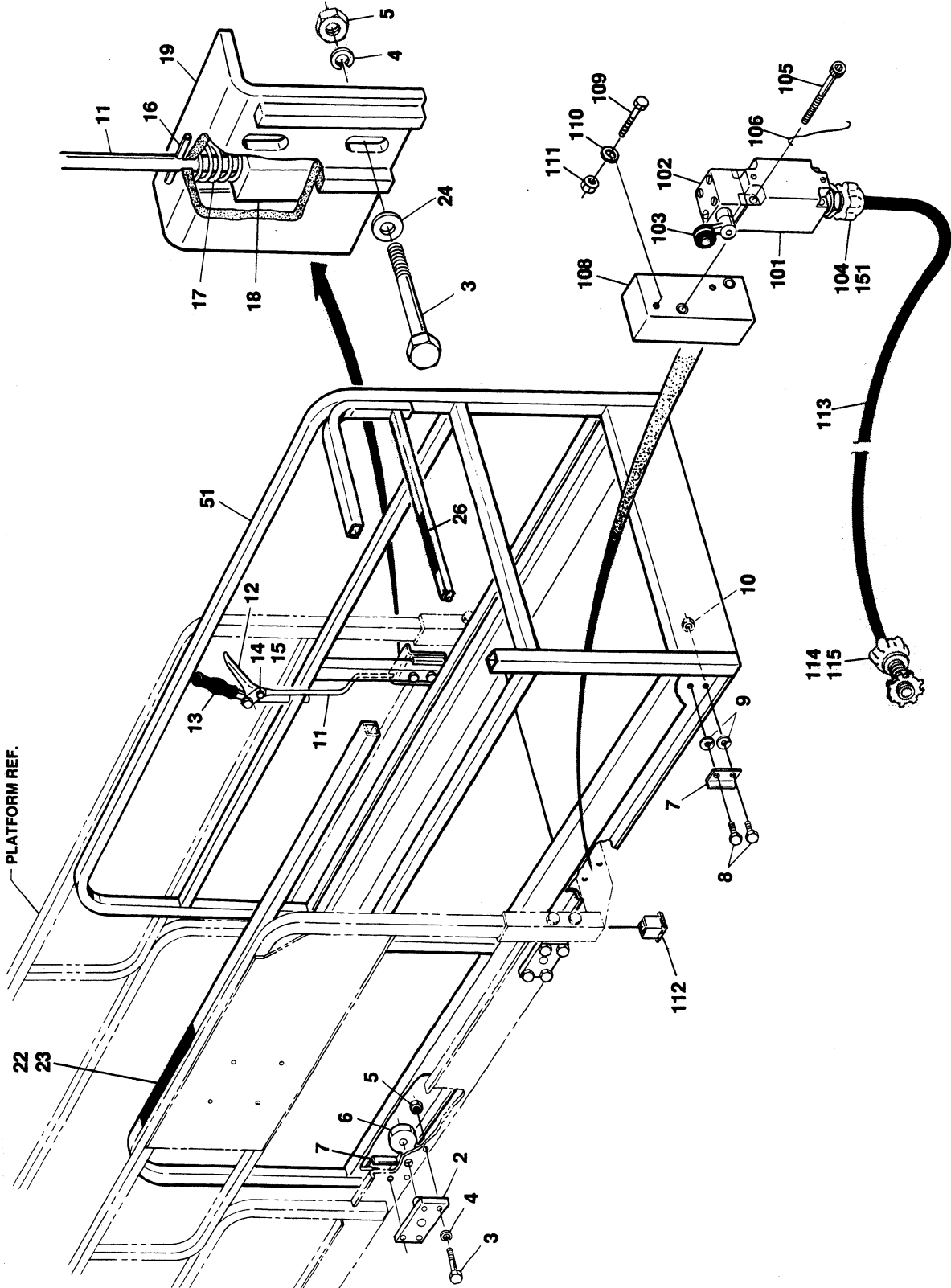
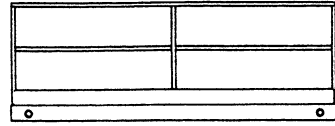

FIGURE & ITEM NO	PART NUMBER	DESCRIPTION	QTY.	REV.
11-4-2		<b>OPTIONAL FOLD-DOWN HANDRAIL INSTALLATIONS (CONTINUED)</b>	Ref.	
	0251843	<b>FOLD-DOWN HANDRAIL INSTALLATION - CM2046 AND CM2546 WITH EXTENDABLE DECK (VARIABLE PARTS)</b>	Ref.	D
-51	Not Required			
-52	Not Required			
-53	Not Required			
-54	3640743	Handrail - Top Rear Vertical	2	
-55	Not Used			
-56	0641416	Bolt 1/4"-20NC x 2"	4	
-57	0641408	Bolt 1/4"-20NC x 1"	4	
-58	3640761	Handrail - Bottom Rear Vertical	2	
-59	3535337	Kickplate - Rear	2	
-60	3640744	Handrail - Rear	1	
-61	4565261	Handrail - Center Rear Vertical	2	
-62	Not Required			
	0251844	<b>FOLD-DOWN HANDRAIL INSTALLATION - CM2558 WITH FIXED DECK (VARIABLE PARTS)</b>	Ref.	E
-51	3534741	Kickplate - Front	1	
-52	4564732	Handrail - Front	2	
-53	3533091	Plate, Mounting - Control Box	1	
-54	3640743	Handrail - Top Rear Vertical	2	
-55	Not Used			
-56	Not Used			
-57	0641408	Bolt 1/4"-20NC x 1"	4	
-58	3640761	Handrail - Bottom Rear Vertical	2	
-59	3535492	Kickplate - Rear	2	
-60	3640745	Handrail - Rear	1	
-61	4565261	Handrail - Center Rear Vertical	2	
-62	4565599	Tube, Support	1	
	0251845	<b>FOLD-DOWN HANDRAIL INSTALLATION - CM2558 WITH EXTENDABLE DECK (VARIABLE PARTS)</b>	Ref.	D
-51	Not Required			
-52	Not Required			
-53	Not Required			
-54	3640743	Handrail - Top Rear Vertical	2	
-55	Not Used			
-56	Not Used			
-57	0641408	Bolt 1/4"-20NC x 1"	4	
-58	3640761	Handrail - Bottom Rear Vertical	2	
-59	3535492	Kickplate - Rear	2	
-60	3640745	Handrail - Rear	1	
-61	4565261	Handrail - Center Rear Vertical	2	
-62	Not Required			

SECTION 11 - 4 PLATFORM

# SECTION 11-4 PLATFORM CM2033/CM2046/CM2546/CM2558

FIGURE 11-4-3. OPTIONAL EXTENDABLE DECK  
INSTALLATION WITH STANDARD HANDRAILS.



# SECTION 11-4 PLATFORM CM2033/CM2046/CM2546/CM2558

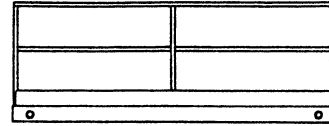

FIGURE & ITEM NO	PART NUMBER	DESCRIPTION	QTY.	REV.
11-4-3		<b>OPTIONAL EXTENDABLE DECK INSTALLATION WITH STANDARD HANDRAILS</b>	Ref.	
	1281415	<b>EXTENDABLE DECK INSTALLATION (STANDARD PARTS WHEN EQUIPPED)</b>	Ref.	F
—1	Not Used			
—2	4843706	Mounting Weldment - Roller	4	
—3	0641508	Bolt 5/16"-18NC x 1"	16	
—4	4761500	Lockwasher 5/16"	18	
—5	3311501	Nut 5/16"-18NC	16	
—6	3860052	Roller	4	
	4712200	Shim, Flatwasher (Steel)	A/R	
	4740066	Shim, Flatwasher (Thin Bronze)	A/R	
—7	0181684	Angle, Stop	4	
—8	0641408	Bolt 1/4"-20NC x 1"	8	
—9	4761400	Lockwasher 1/4"	12	
—10	3311401	Nut 1/4"-20NC	8	
—11	3841074	Rod, Release	1	
—12	2980113	Release Lever Assembly	1	
—13	2560088	Grip, Handle	1	
—14	0641406	Bolt 1/4"-20NC x 3/4"	1	
—15	3311405	Locknut 1/4"-20NC	1	
—16	3440413	Rollpin 1/8" x 13/16"	2	
—17	4160078	Spring	1	
—18	0361912	Bar, Latch	1	
—19	2940061	Latch Weldment	1	
—20	Not Used			
—21	Not Used			
—22	Not Used			
—23	3820001	Rivet	2	
—24	4751500	Flatwasher 5/16"	4	
—25	0641516	Bolt 5/16"-18NC x 2"	2	
—26	3252136	Nameplate - Control Box Location	1	
	0251634	<b>EXTENDABLE DECK INSTALLATION (CM2033) (VARIABLE PARTS)</b>	Ref.	D
	0251635	<b>EXTENDABLE DECK INSTALLATION (CM2046/2546) (VARIABLE PARTS)</b>	Ref.	C
	0251636	<b>EXTENDABLE DECK INSTALLATION (CM2558) (VARIABLE PARTS)</b>	Ref.	C
—51		<b>EXTENDABLE PLATFORM DECK OPTIONS:</b>		
	3510490	Extendable Platform Deck (CM2033)	1	
	3510325	Extendable Platform Deck (CM2046 and CM2546)	1	
	3510326	Extendable Platform Deck (CM2558)	1	

SECTION 11-4 PLATFORM



# SECTION 11-4 PLATFORM CM2033/CM2046/CM2546/CM2558

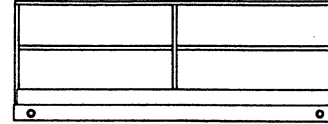

FIGURE & ITEM NO	PART NUMBER	DESCRIPTION	QTY.	REV.
11-4-3		<b>OPTIONAL EXTENDABLE DECK INSTALLATION WITH STANDARD HANDRAILS (CONTINUED)</b>	Ref.	
		<b>PLATFORM EXTENSION LIMIT SWITCH INSTALLATION (FRENCH AND ITALIAN SPECS)</b>	Ref.	
-101	4360277	Switch, Limit	1	
-102	4360236	Actuator, Switch	1	
-103	4360278	Roller and Arm	1	
-104	4460052	Connector, Strain Relief	1	
-105	3900168	Screw, Special	2	
-106	4920140	Lockwire	2	
-107	Not Used			
-108	3534995	Plate, Mounting	1	
-109	3931416	Bolt, Socket Head 1/4"-20NC x 1"	2	
-110	3311401	Nut 1/4"-20NC	2	
-111	4761400	Lockwasher 1/4"	2	
-112	3520072	Plug, Cap	1	
-113	1060341	Cable, Electrical - 16/2	A/R	
-114	3300047	Locknut, Conduit	1	
-115	0960239	Bushing	1	
	0251705	<b>PLATFORM EXTENSION LIMIT SWITCH INSTALLATION (ALL FRENCH SPECS AND ITALIAN SPECS PRIOR TO AUGUST 1993) (VARIABLE PARTS REQUIRED WITH STEEL CONSOLE BOX)</b>	Ref.	B
-151	4460049	Connector, Strain Relief	1	
	0253617/0253618	<b>PLATFORM EXTENSION LIMIT SWITCH INSTALLATION (ALL FRENCH SPECS AND ITALIAN SPECS PRIOR TO AUGUST 1993) (VARIABLE PARTS REQUIRED WITH MOLDED CONSOLE BOX)</b>	Ref.	B/C
	0254320/0254321	<b>PLATFORM EXTENSION LIMIT SWITCH INSTALLATION (ITALIAN SPECS AUGUST 1993 TO PRESENT) (VARIABLE PARTS REQUIRED WITH MOLDED CONSOLE BOX)</b>	Ref.	B/B
-151	4460052	Connector, Strain Relief	1	

SECTION 11 - 4 PLATFORM



# SECTION 11-4 PLATFORM CM2033/CM2046/CM2546/CM2558

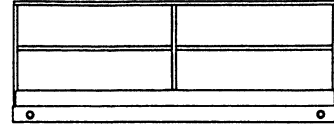

FIGURE & ITEM NO	PART NUMBER	DESCRIPTION	QTY.	REV.
11-4-4		<b>OPTIONAL EXTENDABLE DECK INSTALLATION WITH FOLD-DOWN HANDRAILS</b>	Ref.	
	1281617	<b>EXTENDABLE DECK INSTALLATION (STANDARD PARTS WHEN EQUIPPED)</b>	Ref.	C
-1	Not Used			
-2	3640749	Handrail - Right Side	1	
-3	3640748	Handrail - Left Side	1	
-4	2560088	Grip, Handle	1	
-5	2980113	Release Lever Assembly	1	
-6	3841130	Rod, Release	1	
-7	3860052	Roller	4	
	4712200	Shim, Flatwasher (Steel)	A/R	
	4740066	Shim, Flatwasher (Thin Bronze)	A/R	
-8	4843706	Mounting Weldment - Roller	4	
-9	0641510	Bolt 5/16"-18NC x 1 1/4"	16	
-10	4761500	Lockwasher 5/16"	18	
-11	3311501	Nut 5/16"-18NC	18	
-12	0181684	Angle	4	
-13	0641406	Bolt 1/4"-20NC x 3/4"	8	
-14	4761400	Lockwasher 1/4"	12	
-15	3311401	Nut 1/4"-20NC	8	
-16	3430416	Pin, Clevis 1/4" x 2"	4	
-17	4711400	Flatwasher 1/4" Narrow	12	
-18	3450203	Pin, Cotter 1/16" x 3/4"	4	
-19	3421913	Pin, Quick Release	2	
-20	1260017	Chain (2 Lengths 7 in./17.8 Each)	14 in./35.8cm	
-21	0641406	Bolt 1/4"-20NC x 3/4"	1	
-22	3311405	Locknut 1/4"-20NC	3	
-23	0641516	Bolt 5/16"-18NC x 2"	2	
-24	4751500	Flatwasher 5/16"	4	
-25	3440413	Rollpin 1/8" x 13/16"	2	
-26	4160078	Spring	1	
-27	0361912	Bar, Latch	1	
-28	2940061	Latch Weldment	1	
-29	0641416	Bolt 1/4"-20NC x 2"	2	
	0251942	<b>EXTENDABLE DECK INSTALLATION (CM2033) (VARIABLE PARTS)</b>	Ref.	D
	0251943	<b>EXTENDABLE DECK INSTALLATION (CM2046/2546) (VARIABLE PARTS)</b>	Ref.	C
	0251944	<b>EXTENDABLE DECK INSTALLATION (CM2558) (VARIABLE PARTS)</b>	Ref.	C
-51		<b>PLATFORM DECK WELDMENT OPTIONS:</b>		
	3510491	Platform Deck Weldment (CM2033)	1	
	3510346	Platform Deck Weldment (CM2046 and CM2546)	1	
	3510347	Platform Deck Weldment (CM2558)	1	

SECTION 11-4 PLATFORM





# SECTION 11-4 PLATFORM CM2033/CM2046/CM2546/CM2558

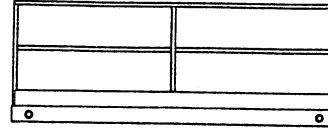
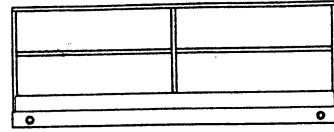

FIGURE & ITEM NO	PART NUMBER	DESCRIPTION	QTY.	REV.
11-4-4		<b>OPTIONAL EXTENDABLE DECK INSTALLATION WITH FOLD-DOWN HANDRAILS (CONTINUED)</b>	Ref.	
		<b>PLATFORM EXTENSION LIMIT SWITCH INSTALLATION (FRENCH AND ITALIAN SPECS)</b>	Ref.	
-101	4360277	Switch, Limit	1	
-102	4360236	Actuator, Switch	1	
-103	4360278	Roller and Arm	1	
-104	4460052	Connector, Strain Relief	2	
-105	3900168	Screw, Special	2	
-106	4920140	Lockwire	2	
-107	Not Used			
-108	3534995	Plate, Mounting	1	
-109	3931416	Bolt, Socket Head 1/4"-20NC x 1"	2	
-110	3311401	Nut 1/4"-20NC	2	
-111	4761400	Lockwasher 1/4"	2	
-112	3520072	Plug, Cap	1	
-113	1060341	Cable, Electrical - 16/2	A/R	
-114	3300047	Locknut, Conduit	1	
-115	0960239	Bushing	1	
	0251705	<b>PLATFORM EXTENSION LIMIT SWITCH INSTALLATION (ALL FRENCH SPECS AND ITALIAN SPECS PRIOR TO AUGUST 1993) (VARIABLE PARTS REQUIRED WITH STEEL CONSOLE BOX)</b>	Ref.	B
-151	4460049	Connector, Strain Relief	1	
	0253617/0253618	<b>PLATFORM EXTENSION LIMIT SWITCH INSTALLATION (ALL FRENCH SPECS AND ITALIAN SPECS PRIOR TO AUGUST 1993) (VARIABLE PARTS REQUIRED WITH MOLDED CONSOLE BOX)</b>	Ref.	B/C
	0254320/0254321	<b>PLATFORM EXTENSION LIMIT SWITCH INSTALLATION (ITALIAN SPECS AUGUST 1993 TO PRESENT) (VARIABLE PARTS REQUIRED WITH MOLDED CONSOLE BOX)</b>	Ref.	B/B
-151	4460052	Connector, Strain Relief	1	

SECTION 11-4 PLATFORM

# SECTION 11-4 PLATFORM CM2033/CM2046/CM2546/CM2558

FIGURE 11-4-5. STEEL PLATFORM CONSOLE BOX ASSEMBLY.



SECTION 11-4 PLATFORM

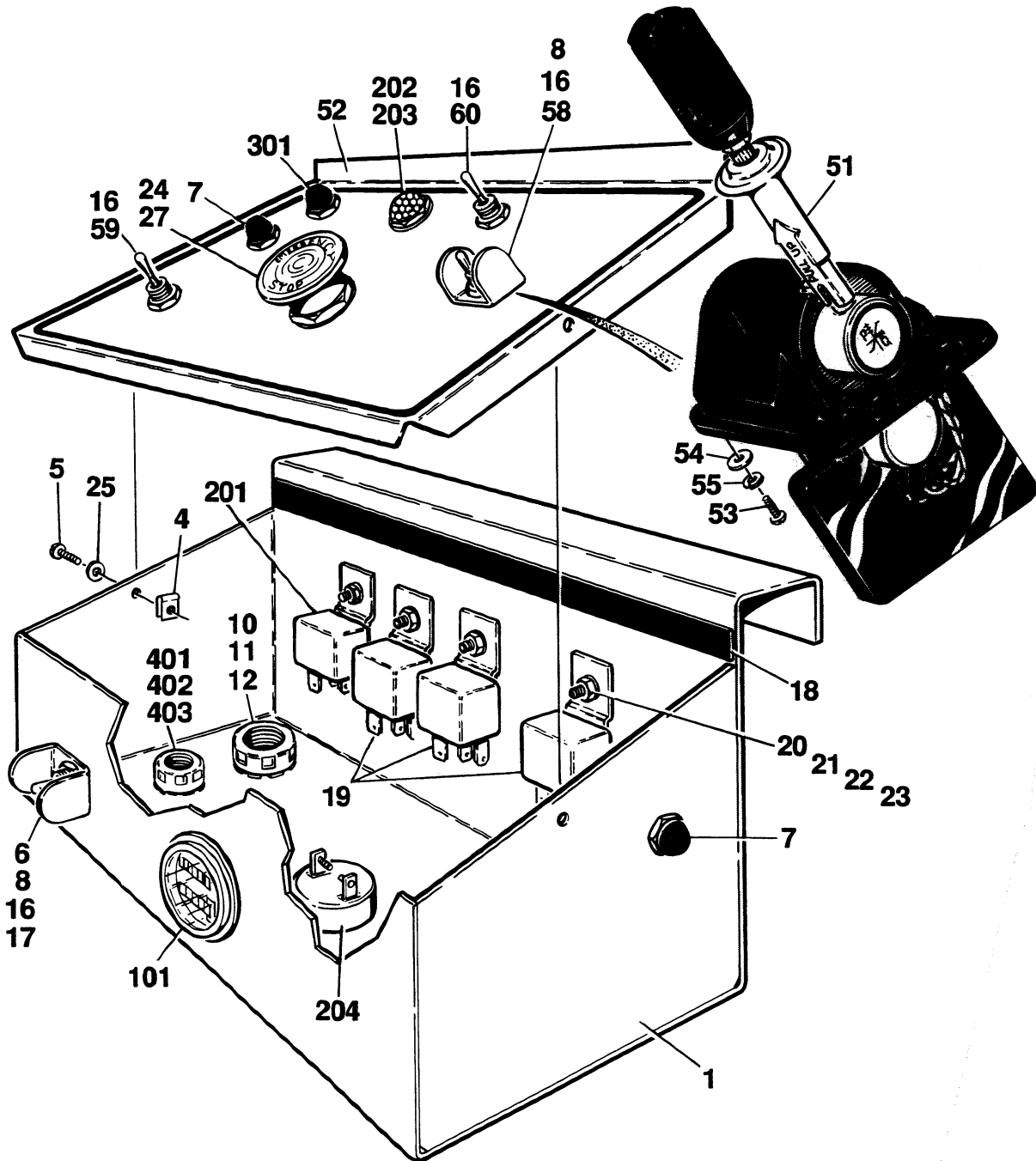

# SECTION 11-4 PLATFORM CM2033/CM2046/CM2546/CM2558

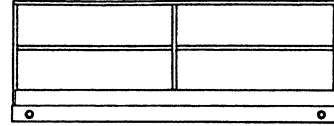

FIGURE & ITEM NO	PART NUMBER	DESCRIPTION	QTY.	REV.
11-4-5		<b>STEEL PLATFORM CONSOLE BOX ASSEMBLY</b>	Ref.	
		<b>CONSOLE BOX ASSEMBLY (STANDARD PARTS)</b>	Ref.	
—1	3534838	Box	1	
—2	Not Used			
—3	Not Used			
—4	3300177	Nut, Tinnerman	2	
—5	0751006	Screw, Machine #10 x 3/4"	2	
—6	4360202	Switch, Toggle - DPDT/MC/CO (Lift)	1	
—7	4360274	Switch, Push Button - SPST (Posi Trac)	1	
—8	4060229	Shield, Switch	A/R	
—9	Not Used			
—10	4460051	Connector, Strain Relief	1	
—11	3300048	Locknut, Conduit	1	
—12	0960238	Bushing	1	
—13	Not Used			
—14	Not Used			
—15	Not Used			
—16	3790012	O-Ring	A/R	
—17	1701453	Nametag - Lift	1	
—18	4420008	Tape, Insulation	32 in./8m	
—19	3740069	Relay, Power	A/R	
—20	3910608	Screw, Machine #6 x 1/2"	A/R	
—21	4760600	Lockwasher #6	A/R	
—22	4750600	Flatwasher #6	A/R	
—23	3310601	Nut #6-32NC	2	
—24	4360289	Switch, Push-Pull (Emergency Stop)	1	
—25	4740120	Washer, Nylon	2	
—26	Not Used			
—27	0100035	Loctite #222	A/R	
	0251671	<b>CONSOLE BOX ASSEMBLY (WITH TOGGLE SWITCH DRIVE - STANDARD) (VARIABLE PARTS)</b>	Ref.	G
	0252378	<b>CONSOLE BOX ASSEMBLY (WITH TOGGLE SWITCH DRIVE - FRENCH) (VARIABLE PARTS)</b>	Ref.	—
—51	Not Required			
—52	3252090	Lid, Control Box	1	
—53	Not Required			
—54	Not Required			
—55	Not Required			
—56	Not Used			
—57	Not Used			
—58	4360202	Switch, Toggle - DPDT/MC/CO (Drive)	1	
—59	4360198	Switch, Toggle - SPDT/MC/CO (Steer)	1	
—60	4360092	Switch, Toggle - (Drive Speed)	1	

SECTION 11 - 4 PLATFORM



# SECTION 11-4 PLATFORM CM2033/CM2046/CM2546/CM2558

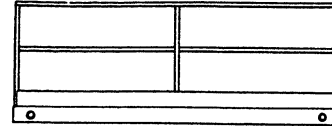
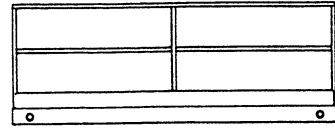

FIGURE & ITEM NO	PART NUMBER	DESCRIPTION	QTY.	REV.
11-4-5		<b>STEEL PLATFORM CONSOLE BOX ASSEMBLY (CONTINUED)</b>	Ref.	
	0251670	<b>CONSOLE BOX ASSEMBLY (WITH PQ CONTROLLER/ BANG-BANG DRIVE - STANDARD) (VARIABLE PARTS)</b>	Ref.	G
	0253076	<b>CONSOLE BOX ASSEMBLY (WITH PQ CONTROLLER/ BANG-BANG DRIVE - FRENCH) (VARIABLE PARTS)</b>	Ref.	—
—51	1600132	Controller, PQ	1	
—52	3252089	Lid, Control Box	1	
—53	0720803	Screw, Machine #8 x 3/8"	4	
—54	4750800	Flatwasher #8	4	
—55	4760800	Lockwasher #8	4	
—56	Not Used			
—57	Not Used			
—58	Not Required			
—59	Not Required			
—60	Not Required			
	0252421	<b>CONSOLE BOX ASSEMBLY (WITH PQ CONTROLLER/ PROPORTIONAL DRIVE - STANDARD) (VARIABLE PARTS)</b>	Ref.	—
—51	1600143	Controller, PQ	1	
—52	3252089	Lid, Control Box	1	
—53	0720803	Screw, Machine #8 x 3/8"	4	
—54	4750800	Flatwasher #8	4	
—55	4760800	Lockwasher #8	4	
—56	Not Used			
—57	Not Used			
—58	Not Required			
—59	Not Required			
—60	Not Required			
	0251758	<b>OPTIONAL BATTERY/HOUR GAUGE INSTALLATION</b>	Ref.	B
—101	2420106	Gauge, Battery/Hour	1	
		<b>TILT INDICATOR INSTALLATION</b>	Ref.	
—201	3740069	Relay, Power	1	
—202	2920026	Light, Indicator - Red	1	
—203	2920094	Bulb, Light	1	
—204	0140011	Alarm, Sonalert	1	
	0251788	<b>OPTIONAL HORN INSTALLATION</b>	Ref.	B
—301	4360274	Switch, Push Button	1	
		<b>OPTIONAL BEACON LIGHT INSTALLATION</b>	Ref.	
—401	4460049	Connector, Strain Relief	1	
—402	0960239	Bushing	1	
—403	3300047	Locknut, Conduit	1	

SECTION 11 - 4 PLATFORM

# SECTION 11-4 PLATFORM CM2033/CM2046/CM2546/CM2558

FIGURE 11-4-6. MOLDED PLATFORM CONSOLE BOX ASSEMBLY.



SECTION 11-4 PLATFORM

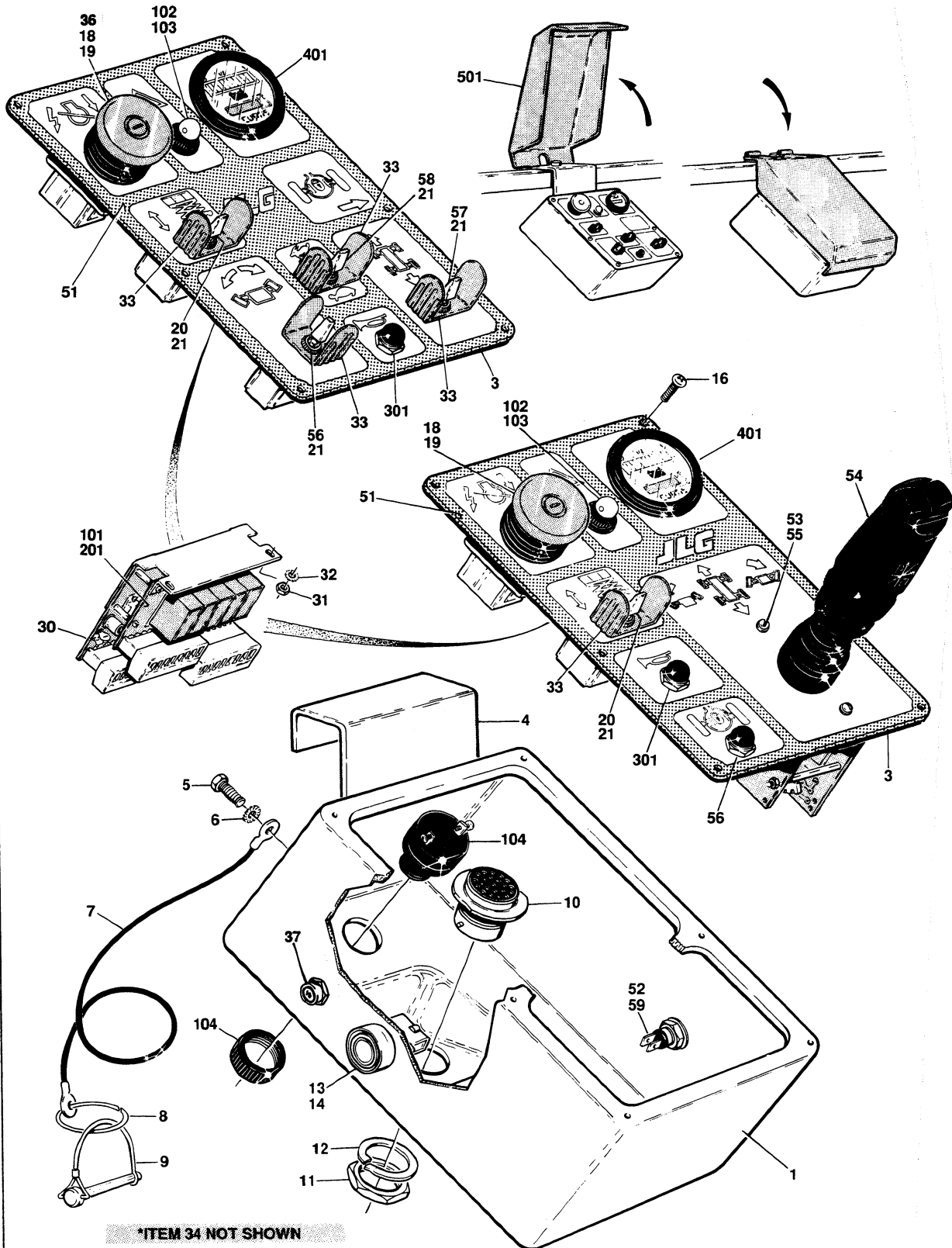

# SECTION 11-4 PLATFORM CM2033/CM2046/CM2546/CM2558

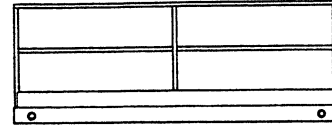

**SECTION 11 - 4 PLATFORM**

FIGURE & ITEM NO	PART NUMBER	DESCRIPTION	QTY.	REV.
11-4-6		<b>MOLDED PLATFORM CONSOLE BOX ASSEMBLY</b>	Ref.	
		<b>CONSOLE BOX ASSEMBLY (STANDARD PARTS)</b>	Ref.	
-1	0860784	Box, Console	1	
-2	Not Used			
-3	4420008	Tape, Insulation	32 in./8m	
-4	0901859	Bracket, Hanger	1	
-5	0641404	Bolt 1/4"-20NC x 1/2"	4	
-6	4791400	Starwasher 1/4"	4	
-7	1060380	Lanyard - 10"/25.4cm	1	
-8	3760170	Ring	1	
-9	3421453	Pin, Snapper	1	
-10	4460463	Receptacle, Terminal	1	
-11	4460470	Nut, Panel	1	
-12	4460471	Lockwasher	1	
-13	4360339	Switch, Push Button	1	
	7012593	Boot, Green Rubber	1	
-14	4360267	Switch, Contact - N.O.	1	
-15	Not Used			
-16	3900177	Screw	6	
-17	Not Used			
-18	4360289	Switch, Push/Pull (Emergency Stop)	1	
	7012611	Lens	1	
	7012612	Boot	1	
-19	0100035	Loctite#222	A/R	
-20	4360318	Switch, Toggle - DPDT/MC	1	
-21	3790012	O-Ring	A/R	
-22	Not Used			
-23	Not Used			
-24	Not Used			
-25	Not Used			
-26	Not Used			
-27	Not Used			
-28	Not Used			
-29	Not Used			
-30	0610101	Card, Circuit (RAM) (Prior to January 1995)	1	
	0610113	Card, Circuit (Jenesco) (January 1995 to Present)	1	
	0610110	Bracket, Replacement	1	
	7012658	Fuse - 7.5 Amp	1	
-31	3310601	Nut 36-32NC	2	
-32	4770600	Starwasher #6	A/R	
-33	4060802	Shield, Switch	1	
-34	1701827	Decal - Legend	1	
-35	Not Used			
-36	4740066	Washer, Thrust	2	
-37	4360112	Breaker, Circuit (October 1993 to Present)	1	
	0253099	<b>CONSOLE BOX ASSEMBLY (WITH TOGGLE SWITCH DRIVE - STANDARD)</b>	Ref.	H
	0253398	<b>CONSOLE BOX ASSEMBLY (WITH TOGGLE SWITCH DRIVE - FRENCH)</b>	Ref.	G
-51	3252196	Lid, Control Box (Prior to January 1993)	1	
	3252253	Lid, Control Box (January 1993 to Present)	1	

# SECTION 11-4 PLATFORM

## CM2033/CM2046/CM2546/CM2558

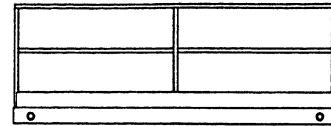

SECTION 11-4 PLATFORM

FIGURE & ITEM NO	PART NUMBER	DESCRIPTION	QTY.	REV.
11-4-6		<b>MOLDED PLATFORM CONSOLE BOX ASSEMBLY (CONTINUED)</b>	Ref.	
-52	4360274	Switch, Push Button - SPST (Posi Trac)	1	
-53	Not Required			
-54	Not Required			
-55	Not Required			
-56	4360328	Switch, Toggle - SPST/MC/CO (Steer)	1	
-57	4360314	Switch, Toggle - DPDT/MC/CO (Drive)	1	
-58	4360345	Switch, Toggle - SPDT (Drive Speed)(2SPD - Prior to January 1993)	1	
	4360355	Switch, Toggle - DPDT (Drive Speed) (3SPD - January 1993 to Present)	1	
-59	Not Required			
	0253101	<b>CONSOLE BOX ASSEMBLY (WITH PQ CONTROLLER/ BANG-BANG DRIVE - STANDARD)</b>	Ref.	G
	0253401	<b>CONSOLE BOX ASSEMBLY (WITH PQ CONTROLLER/ BANG-BANG DRIVE - FRENCH)</b>	Ref.	E
-51	3252194	Lid, Control Box	1	
-52	3520026	Plug, Hole	1	
-53	4740120	Washer, Nylon	2	
-54	1600156	Controller, PQ	1	
-55	3900178	Screw, Machine #10-32NF x 3/4"	2	
-56	4360274	Switch, Push Button - SPST (Posi-Trac)	1	
-57	Not Required			
-58	Not Required			
-59	0100009	Sealant, Silicon	A/R	
	0253405	<b>CONSOLE BOX ASSEMBLY (WITH PQ CONTROLLER/ PROPORTIONAL DRIVE - STANDARD)</b>	Ref.	E
	0253406	<b>CONSOLE BOX ASSEMBLY (WITH PQ CONTROLLER/ PROPORTIONAL DRIVE - FRENCH)</b>	Ref.	E
-51	3252194	Lid, Control Box	1	
-52	3520026	Plug, Hole	1	
-53	4740120	Washer, Nylon	2	
-54	1600160	Controller, PQ	1	
-55	3900178	Screw, Machine #10-32NF x 3/4"	2	
-56	4360274	Switch, Push Button - SPST (Posi-Trac)	1	
-57	Not Required			
-58	Not Required			
-59	0100009	Sealant, Silicon	A/R	
		<b>TILT INDICATOR INSTALLATION</b>	Ref.	
-101	0610105	Card, Circuit - Relay	1	
	0610110	Bracket, Mounting	1	
-102	2920094	Bulb, Light	1	
-103	2920026	Light, Indicator - Red	1	
-104	0140011	Alarm, Sonalert	1	



# SECTION 11-4 PLATFORM CM2033/CM2046/CM2546/CM2558

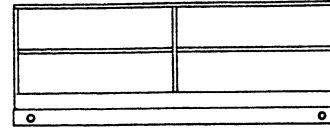
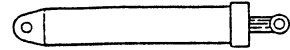

FIGURE & ITEM NO	PART NUMBER	DESCRIPTION	QTY.	REV.
11-4-6		<b>MOLDED PLATFORM CONSOLE BOX ASSEMBLY (CONTINUED)</b>	Ref.	
		<b>DRIVE CUT-OUT INSTALLATION</b>	Ref.	
—201	0610105	Card, Circuit - Relay	1	
	0610110	Bracket, Mounting	1	
	0253465	<b>OPTIONAL HORN INSTALLATION</b>	Ref.	—
—301	4360274	Switch, Push Button	1	
	4921537	Harness, Switch	1	
	0253499	<b>OPTIONAL BATTERY/HOUR GAUGE INSTALLATION</b>	Ref.	A
—401	2420106	Gauge, Battery/Hour	1	
	0253548	<b>OPTIONAL CONSOLE BOX INSTALLATION</b>	Ref.	—
—501	4844327	Cover	1	

**SECTION 11-4 PLATFORM**



**SECTION 11-5 CYLINDERS  
CM2033/CM2046/CM2546/CM2558**



**TABLE OF CONTENTS**

<b>FIGURE NO.</b>	<b>TITLE</b>	<b>PAGE NO.</b>
11-5-1	Brake Cylinder Assembly (Prior to March 1992) .....	11-5-2
11-5-2	Brake Cylinder Assembly (March 1992 to Present) .....	11-5-4
11-5-3	Lift Cylinder Sub-Assembly .....	11-5-6
11-5-4	Steer Cylinder Assembly .....	11-5-10

**S  
E  
C  
T  
I  
O  
N  
  
1  
1  
-  
5  
  
C  
Y  
L  
I  
N  
D  
E  
R  
S**

**SECTION 11-5 CYLINDERS  
CM2033/CM2046/CM2546/CM2558**

**FIGURE 11-5-1. BRAKE CYLINDER ASSEMBLY  
(PRIOR TO MARCH 1992).**

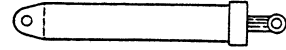

**SECTION 11-5 CYLINDERS**

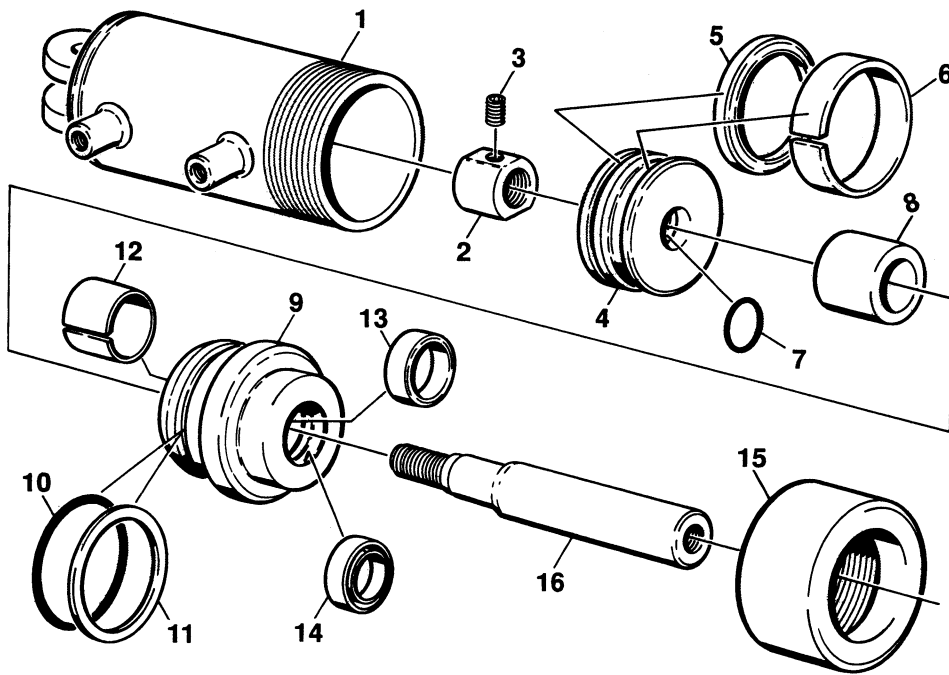

**SECTION 11-5 CYLINDERS  
CM2033/CM2046/CM2546/CM2558**

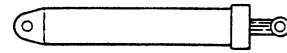
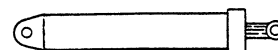

FIGURE & ITEM NO	PART NUMBER	DESCRIPTION	QTY.	REV.
11-5-1	1682445	<b>BRAKE CYLINDER ASSEMBLY (PRIOR TO MARCH 1992)</b>	Ref.	A
—1	1682446	Barrel	1	
—2	3300272	Nut	1	
	0100011	Loctite #242	A/R	
—3	3900170	Setscrew 3/8"-16NC x 3/8"	1	
—4	3480157	Piston	1	
—5	Kit	Seal, Piston	1	
—6	Kit	Ring, Wear	1	
—7	Kit	O-Ring	1	
—8	4565069	Tube, Spacer	1	
—9	1682449	Head	1	
—10	Kit	O-Ring	1	
—11	Kit	Ring, Back-Up	1	
—12	Kit	Ring, Wear	1	
—13	Kit	Seal, Rod	1	
—14	Kit	Wiper	1	
—15	1120083	Retainer	1	
	0100035	Loctite #222	A/R	
—16	1682448	Rod	1	
	2901187	----- Seal Kit (Includes Items 5,6,7,10,11,12,13 and 14)	1	

**SECTION 11-5 CYLINDERS**

**SECTION 11-5 CYLINDERS  
CM2033/CM2046/CM2546/CM2558**

**FIGURE 11-5-2. BRAKE CYLINDER ASSEMBLY  
(MARCH 1992 TO PRESENT).**



**SECTION 11-5 CYLINDERS**

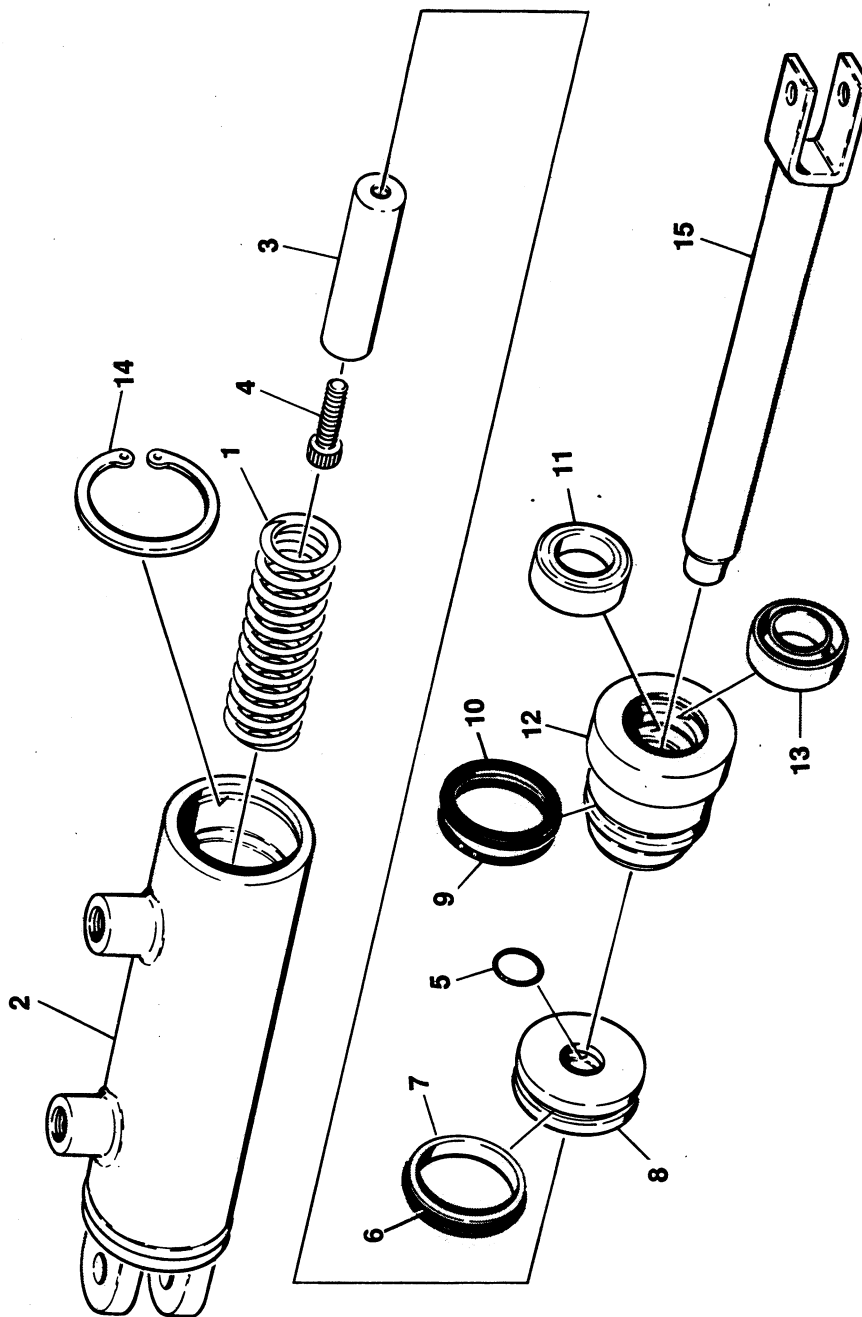

# SECTION 11-5 CYLINDERS CM2033/CM2046/CM2546/CM2558

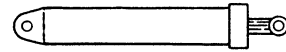
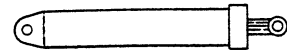

FIGURE & ITEM NO	PART NUMBER	DESCRIPTION	QTY.	REV.
11-5-2	1682277	<b>BRAKE CYLINDER ASSEMBLY (MARCH 1992 TO DECEMBER 1993)</b> <b>Note: When replacing complete 1682277 cylinder recommend using 1683098 cylinder.</b>	Ref.	—
	1683098	<b>BRAKE CYLINDER ASSEMBLY (DECEMBER 1993 TO PRESENT)</b>	Ref.	—
—1	7001093	Spring, Compression (1682277 Cylinder)	1	
	7001618	Spring, Compression (1683098 Cylinder)	1	
—2	Not Available	Barrel, Cylinder	1	
—3	7001094	Spacer (1682277 Cylinder)	1	
	7001620	Spacer (1683098 Cylinder)	1	
—4	7001095	Bolt, Socket Head	1	
—5	Kit	O-Ring	1	
—6	Kit	Ring, Piston	1	
—7	Kit	O-Ring	1	
—8	7001096	Piston	1	
—9	Kit	O-Ring	1	
—10	Kit	Ring, Back-up	1	
—11	Kit	Seal	1	
—12	7001097	Head	1	
—13	Kit	Ring, Wiper	1	
—14	7001098	Ring, Retaining	1	
—15	7001099	Rod Weldment (1682277 Cylinder)	1	
	7001621	Rod Weldment (1683098 Cylinder)	1	
	7001092	----- Seal Kit (Includes Items 5,6,7,9,10,11 and 13)	1	

**SECTION 11-5 CYLINDERS**

# SECTION 11-5 CYLINDERS CM2033/CM2046/CM2546/CM2558

FIGURE 11-5-3. LIFT CYLINDER SUB-ASSEMBLY.



SECTION 11-5 CYLINDERS

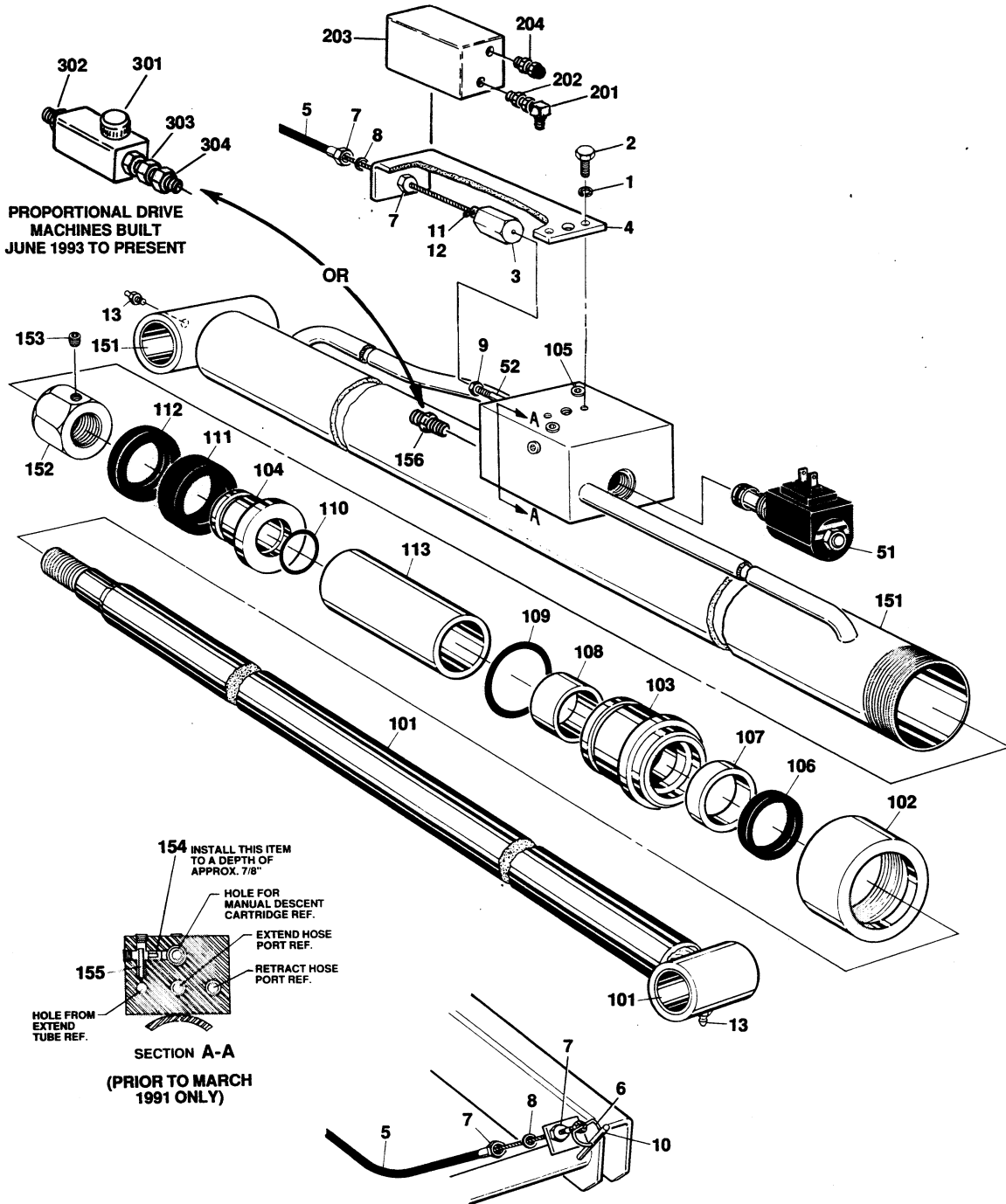



# SECTION 11-5 CYLINDERS CM2033/CM2046/CM2546/CM2558

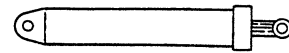
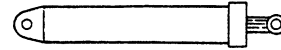

FIGURE & ITEM NO	PART NUMBER	DESCRIPTION	QTY.	REV.
11-5-3		<b>LIFT CYLINDER SUB-ASSEMBLY</b>	Ref.	
		<b>VALVES AND CONTROLS INSTALLATION (STANDARD PARTS)</b>	Ref.	
—1	4761500	Lockwasher 5/16"	2	
—2	0641506	Bolt 5/16"-18NC x 3/4"	2	
—3	0080190	Adapter	1	
—4	0901757	Bracket, Cable	1	
—5	1060377	Cable Assembly	1	
—6	3760170	D-Ring	1	
—7	3321402	Nut, Jam 1/4"-28NF	4	
—8	4751400	Flatwasher 1/4"	2	
—9	3311402	Nut, Jam 1/4"-20NC	1	
—10	3841127	Rod, Handle	1	
—11	3450405	Pin, Cotter	1	
—12	4220044	Stop, Throttle	1	
—13	2160002	Fitting, Grease	2	
		<b>VALVES AND CONTROLS INSTALLATION - STANDARD MACHINES (VARIABLE PARTS)</b>	Ref.	
—51	4640381	Cartridge, Valve - Solenoid Holding	1	
	7004334	Coil - 24VDC (Modular Controls Version)	1	
	7000644	Coil - 24VDC (Hydraforce Version)	1	
	2900503	Seal Kit (Modular Controls Version)	1	
	2900756	Seal Kit (Hydraforce Version)	1	
—52	4640688	Cartridge, Valve - Manual Pull Control (Prior to August 1991)	1	
	4640717	Cartridge, Valve - Manual Pull Control (August 1991 to Present)	1	
		<b>LIFT CYLINDER ASSEMBLY - CM2033 AND CM2046 (STANDARD PARTS)</b>	Ref.	
—101	1682288	Rod Weldment	1	
	0961520	Bushing, Bronze	1	
—102	1120108	Cap, End	1	
—103	1681283	Head	1	
—104	3480147	Piston	1	
—105	2200221	Plug, Pipe	4	
—106	Kit	Seal, Wiper	1	
—107	Kit	Seal, Rod	1	
—108	Kit	Ring, Wear	1	
—109	Kit	O-Ring	1	
—110	Kit	O-Ring	1	
—111	Kit	Seal, Piston	1	
—112	Kit	Ring, Guidelock	1	
—113	4564885	Tube, Spacer	1	
		-----		

SECTION 11-5 CYLINDER

**SECTION 11-5 CYLINDERS  
CM2033/CM2046/CM2546/CM2558**



**SECTION 11-5 CYLINDERS**

FIGURE & ITEM NO	PART NUMBER	DESCRIPTION	QTY.	REV.
11-5-3		<b>LIFT CYLINDER SUB-ASSEMBLY (CONTINUED)</b>	Ref.	
	0100011	Loctite #242	A/R	
	0100020	Sealant, Pipe	A/R	
	0100035	Loctite #222	A/R	
	0100038	Primer, Locking	A/R	
	2901165	----- Seal Kit (Includes Items 106-112)	1	
	1682302	<b>LIFT CYLINDER ASSEMBLY - CM2033 AND CM2046 BUILT PRIOR TO MARCH 1991 (VARIABLE PARTS)</b>	Ref.	B
		<b>Note: When replacing complete cylinder assembly recommend using P/N 1682501.</b>		
-151	1682301	Barrel Weldment	1	
	0961519	Bushing, Bronze	1	
-152	3300267	Nut (Not Shown)	1	
-153	3951404	Setscrew 1/4"-20NC x 1/2"	2	
-154	2180764	Plug	1	
-155	3421891	Pin	1	
-156	Not Required			
	1682501	<b>LIFT CYLINDER ASSEMBLY - CM2033 AND CM2046 BUILT MARCH 1991 TO PRESENT (VARIABLE PARTS)</b>	Ref.	B
-151	1682502	Barrel Weldment	1	
	0961519	Bushing, Bronze	1	
-152	3300281	Nut, Hex	1	
-153	3900170	Setscrew 3/8"-16NC x 3/8"	1	
-154	Not Required			
-155	Not Required			
-156	2220343	Fitting, Straight	2	
		<b>LIFT CYLINDER ASSEMBLY - CM2546 AND CM2558 (STANDARD PARTS)</b>	Ref.	
-101	1682266	Rod Weldment	1	
	0961520	Bushing, Bronze	1	
-102	1120305	Cap, End	1	
-103	1681423	Head	1	
-104	3480143	Piston	1	
-105	2200221	Plug, Pipe	4	
-106	Kit	Seal, Wiper	1	
-107	Kit	Seal, Rod	1	
-108	Kit	Ring, Wear	1	
-109	Kit	O-Ring	1	
-110	Kit	O-Ring	1	
-111	Kit	Seal, Piston	1	
-112	Kit	Ring, Guidelock	1	
-113	4565008	Tube, Spacer	1	
		-----		

# SECTION 11-5 CYLINDERS CM2033/CM2046/CM2546/CM2558

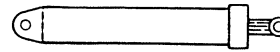

FIGURE & ITEM NO	PART NUMBER	DESCRIPTION	QTY.	REV.
11-5-3		<b>LIFT CYLINDER SUB-ASSEMBLY (CONTINUED)</b>		
	0100011	Loctite #242	A/R	
	0100020	Sealant, Pipe	A/R	
	0100035	Loctite #222	A/R	
	0100038	Primer, Locking	A/R	
	2901158	----- Seal Kit (Includes Items 106-112)	1	
	1682417	<b>LIFT CYLINDER ASSEMBLY - CM2546 AND CM2558 BUILT PRIOR TO MARCH 1991 (VARIABLE PARTS)</b>	Ref.	B
		<b>Note: When replacing complete cylinder assembly recommend using P/N 1682503.</b>		
-151	1682264	Barrel Weldment	1	
	0961519	Bushing, Bronze	1	
-152	3300267	Nut (Not Shown)	1	
-153	3951404	Setscrew 1/4"-20NC x 1/2"	2	
-154	2180764	Plug	1	
-155	3421891	Pin	1	
-156	Not Required			
	1682503	<b>LIFT CYLINDER ASSEMBLY - CM2546 AND CM2558 BUILT MARCH 1991 TO PRESENT (VARIABLE PARTS)</b>	Ref.	D
-151	1682504	Barrel Weldment	1	
	0961519	Bushing, Bronze	1	
-152	3300281	Nut, Hex	1	
-153	3900170	Setscrew 3/8"-16NC x 3/8"	1	
-154	Not Required			
-155	Not Required			
-156	2220343	Fitting, Straight	2	
	0253090	<b>OVERLOAD PROTECTION INSTALLATION (1992 AND NEWER FRENCH SPEC MODELS ONLY)</b>	Ref.	-
-201	2220879	Fitting, 90°	1	
-202	2220440	Fitting, Straight	1	
-203	1692617	Switch, Pressure	1	
-204	4460428	Connector, Strain Relief	1	
	0254204	<b>LIFT CONTROL VALVE INSTALLATION (ONLY PROPORTIONAL DRIVE MACHINES BUILT JUNE 1993 TO PRESENT)</b>	Ref.	A
-301	4640757	Valve, Flow	1	
-302	2220372	Fitting, Straight	1	
-303	2220651	Fitting, Swivel	1	
-304	2220396	Fitting, Straight	1	

**SECTION 11-5 CYLINDERS**

# SECTION 11-5 CYLINDERS CM2033/CM2046/CM2546/CM2558

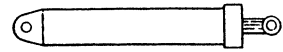
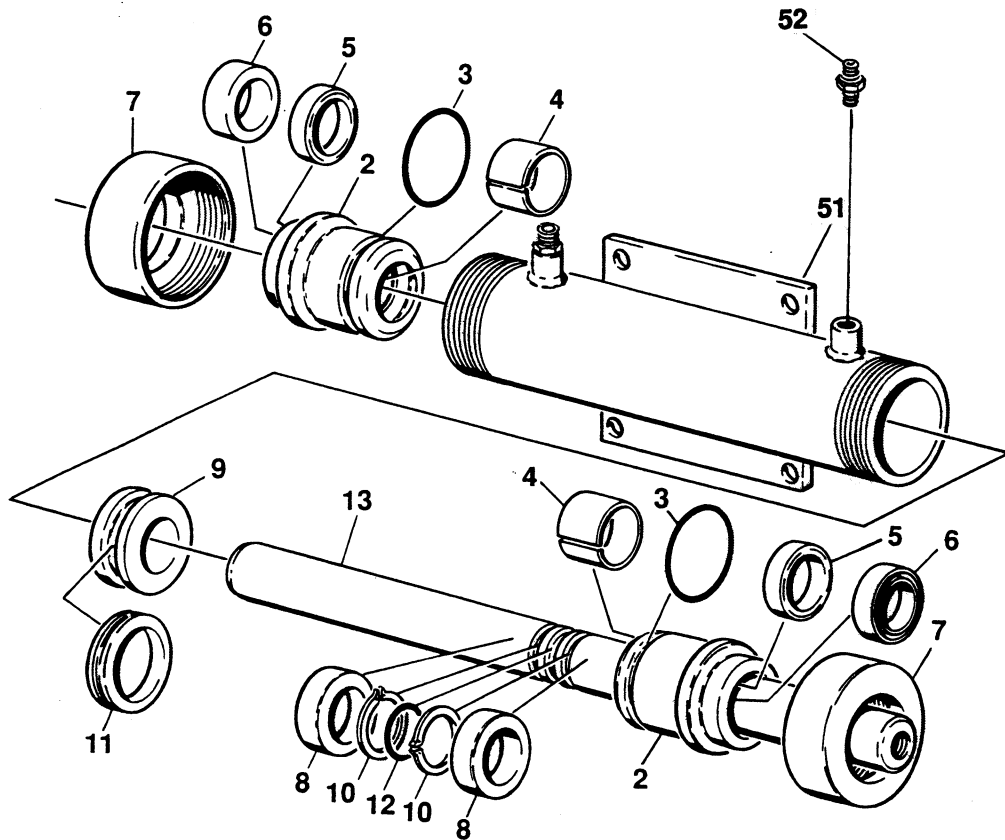

FIGURE 11-5-4. STEER CYLINDER ASSEMBLY.



SECTION 11-5 CYLINDERS

# SECTION 11-5 CYLINDERS CM2033/CM2046/CM2546/CM2558

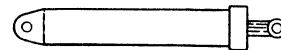

FIGURE & ITEM NO	PART NUMBER	DESCRIPTION	QTY.	REV.
11-5-4		<b>STEER CYLINDER ASSEMBLY (STANDARD PARTS)</b>	Ref.	
—1	Not Used			
—2	1682364	Head	2	
—3	Kit	O-Ring	2	
—4	Kit	Ring, Wear	2	
—5	Kit	Seal, Rod	2	
—6	Kit	Wiper	2	
—7	1120387	Retainer	2	
	0100035	Loctite	A/R	
—8	4564976	Spacer, Tube	2	
—9	3480153	Piston	1	
—10	3760141	Ring, Retaining	2	
—11	Kit	T-Seal	1	
—12	Kit	O-Ring	1	
—13	1682382	Rod	1	
	2901178	Seal Kit (Includes Items 3,4,5,6,11 and 12)	1	
	1682379	<b>STEER CYLINDER ASSEMBLY - ALL MACHINES BUILT PRIOR TO JULY 1993 (VARIABLE PARTS)</b>	Ref.	A
—51	1682380	Barrel	1	
—52	2220414	Fitting, Straight	2	
	1682996	<b>STEER CYLINDER ASSEMBLY - CM2033 BUILT JULY 1993 TO SEPTEMBER 1995 (VARIABLE PARTS)</b>	Ref.	A
—51	1682994	Barrel	1	
—52	2180803	Fitting	2	
	2180421	Orifice (.040) (July 1993 to June 1995)	1	
	2180804	Orifice (.040) (June 1995 to September 1995)	1	
	1682997	<b>STEER CYLINDER ASSEMBLY - CM2046, CM2546 &amp; CM2558 BUILT JULY 1993 TO SEPTEMBER 1995 (VARIABLE PARTS)</b>	Ref.	C
—51	1682994	Barrel	1	
—52	2180803	Fitting	2	
	2180448	Orifice (.062) (July 1993 to June 1995)	1	
	2180805	Orifice (.062) (June 1995 to September 1995)	1	
	1683408	<b>STEER CYLINDER ASSEMBLY - ALL MACHINES BUILT SEPTEMBER 1995 TO PRESENT (VARIABLE PARTS)</b>	Ref.	—
—51	1682994	Barrel	1	
—52	2180803	Fitting	2	
	2180805	Orifice (.062)(CM2046, CM2546 & CM2558)	2	
	2180804	Orifice (.040)(CM2033)	2	
	0255702	<b>OPTIONAL STEER REDUCTION INSTALLATION - CM2046, CM2246 AND CM2558 (NOT SHOWN)</b>	Ref.	—
	2180804	Orifice (.040) (Replace existing orifice)	2	

SECTION 11 - 5 CYLINDERS



**SECTION 11-6 HYDRAULIC  
CM2033/CM2046/CM2546/CM2558**



**TABLE OF CONTENTS**

<b>FIGURE NO.</b>	<b>TITLE</b>	<b>PAGE NO.</b>
11-6-1	Hydraulic Diagram - Bang-Bang Drive .....	11-6-2
11-6-2	Hydraulic Diagram - Proportional Drive .....	11-6-6

**S  
E  
C  
T  
I  
O  
N  
1  
1  
-  
6  
H  
Y  
D  
R  
A  
U  
L  
I  
C**





# SECTION 11-6 HYDRAULICS

## CM2033/CM2046/CM2546/CM2558

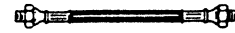

FIGURE & ITEM NO	PART NUMBER	DESCRIPTION	QTY.	REV.
11—6—1	1281465	HYDRAULIC DIAGRAM - BANG-BANG DRIVE	Ref.	J
	2901248	FITTINGS KIT	Ref.	—
—1	2220493	Fitting, 90°	1	
—2	2210008	Fitting, 90°	1	
—3	2220593	Fitting, Straight	1	
—4	2220600	Fitting, Straight	8	
—5	2220386	Fitting, 90°	2	
—6	2220847	Fitting, 90°	2	
—7	2220849	Fitting, Tee	1	
—8	2220620	Fitting, Reducer	1	
—9	2220848	Fitting, Straight	1	
—10	2220362	Fitting, Tee	1	
—11	2220385	Fitting, Tee	2	
—12	2220618	Fitting, Reducer	2	
—13	2220371	Fitting, Straight	1	
—14	2220603	Fitting, Straight	3	
—15	2220852	Fitting, Straight	1	
—16	2210023	Fitting, 90°	1	
—17	2220773	Fitting, 90°	4	
—18	2220512	Fitting	1	
—19	2220490	Fitting, Tee	2	
		HOSE KIT (STANDARD KIT)	Ref.	
—101	2720286	Hose, Suction	33 in./84cm	
—102	2750970	Hose	2	
—103	2752168	Hose	1	
—104	2751874	Hose	1	
—105	2750889	Hose	2	
—106	2751459	Hose	2	
—107	2751526	Hose	1	
—108	2750779	Hose	2	
—109	Not Used			
—110	Not Used			
—111	2751002	Hose	2	
	2901202	HOSE KIT - CM2033 (VARIABLE PARTS)	Ref.	B
—151	2751523	Hose	2	
—152	2751524	Hose	1	
	2901203	HOSE KIT - CM2046, CM2546 AND CM2558 (VARIABLE PARTS)	Ref.	B
—161	2751529	Hose	1	
—162	2751531	Hose	2	

SECTION 11 - 6 HYDRAULICS



# SECTION 11-6 HYDRAULICS CM2033/CM2046/CM2546/CM2558

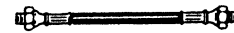

FIGURE & ITEM NO	PART NUMBER	DESCRIPTION	QTY.	REV.
11—6—1	1281465	HYDRAULIC DIAGRAM - BANG-BANG DRIVE (CONTINUED)	Ref.	J
	2901239	TUBE KIT	Ref.	—
—201	4564998	Tube	1	
—202	4564996	Tube	1	
—203	4564997	Tube	1	
—204	4564995	Tube	1	
—205	4564992	Tube	1	
—206	4564993	Tube	1	
—207	4564994	Tube	1	
—208	4564991	Tube	1	
—209	4564988	Tube	1	
—210	4564989	Tube	1	
—211	4564990	Tube	1	
	2791767	HYDRAULIC DIAGRAM - CM2033	Ref.	I
	2791768	HYDRAULIC DIAGRAM - CM2046, CM2546 AND CM2558	Ref.	J
—305	1320030	Clamp	4	
—320	2220850	Fitting, 90°	2	
	7012594	O-Ring Kit (1 per Fitting)	2	
—321	2220851	Fitting, 90°	2	
	7012594	O-Ring Kit (1 per Fitting)	2	
—347	0100011	Loctite #242 (Not Shown)	A/R	

SECTION 11 - 6 HYDRAULICS

# SECTION 11-6 HYDRAULICS CM2033/CM2046/CM2546/CM2558



FIGURE 11-6-2. HYDRAULIC DIAGRAM - PROPORTIONAL DRIVE.

SECTION 11-6 HYDRAULICS

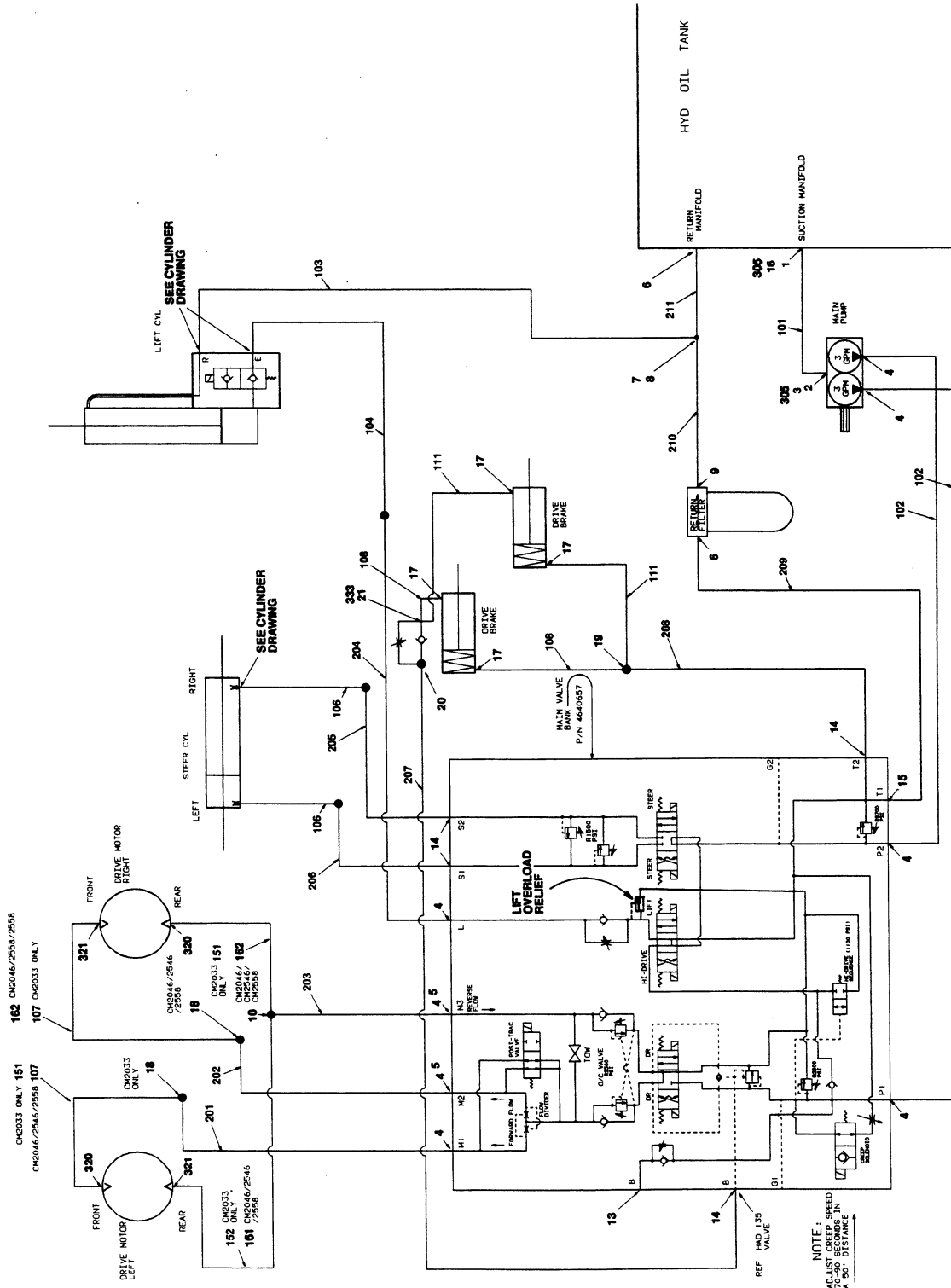

# SECTION 11-6 HYDRAULICS CM2033/CM2046/CM2546/CM2558



FIGURE & ITEM NO	PART NUMBER	DESCRIPTION	QTY.	REV.
11-6-2	1281760	HYDRAULIC DIAGRAM - PROPORTIONAL DRIVE	Ref.	D
	2901254	FITTINGS KIT	Ref.	—
—1	2220493	Fitting, 90°	1	
—2	2210008	Fitting, 90°	1	
—3	2220593	Fitting, Straight	1	
—4	2220600	Fitting, Straight	8	
—5	2220386	Fitting, 90°	2	
—6	2220847	Fitting, 90°	2	
—7	2220849	Fitting, Tee	1	
—8	2220620	Fitting, Reducer	1	
—9	2220848	Fitting, Straight	1	
—10	2220362	Fitting, Tee	1	
—11	2220385	Fitting, Tee	2	
—12	2220618	Fitting, Reducer	2	
—13	2220237	Fitting	1	
—14	2220603	Fitting, Straight	4	
—15	2220852	Fitting, Straight	1	
—16	2210023	Fitting, 90°	1	
—17	2220773	Fitting, 90°	4	
—18	2220512	Fitting	1	
—19	2220490	Fitting, Tee	1	
—20	2220399	Fitting, Straight	1	
—21	2220740	Fitting, Tee	1	
		HOSE KIT (STANDARD PARTS)	Ref.	
—101	2720286	Hose, Suction	1	
—102	2750970	Hose	2	
—103	2752168	Hose	1	
—104	2751874	Hose	1	
—105	Not Used			
—106	2751459	Hose	2	
—107	2751526	Hose	1	
—108	2750779	Hose	2	
—109	Not Used			
—110	Not Used			
—111	2751002	Hose	2	
	2901245	HOSE KIT - CM2033 (VARIABLE PARTS)	Ref.	—
—151	2751523	Hose	2	
—152	2751524	Hose	1	
	2901246	HOSE KIT - CM2046, CM2546 AND CM2558 (VARIABLE PARTS)	Ref.	—
—161	2751529	Hose	1	
—162	2751531	Hose	2	

SECTION 11-6 HYDRAULICS

# SECTION 11-6 HYDRAULICS

## CM2033/CM2046/CM2546/CM2558

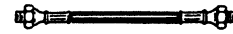

FIGURE & ITEM NO	PART NUMBER	DESCRIPTION	QTY.	REV.
11—6—2	1281760	<b>HYDRAULIC DIAGRAM - PROPORTIONAL DRIVE (CONTINUED)</b>	Ref.	D
	2901247	Tube Kit	Ref.	—
—201	4564998	Tube	1	
—202	4566036	Tube	1	
—203	4566037	Tube	1	
—204	4564995	Tube	1	
—205	4564992	Tube	1	
—206	4564993	Tube	1	
—207	4566038	Tube	1	
—208	4564991	Tube	1	
—209	4564988	Tube	1	
—210	4564989	Tube	1	
—211	4564990	Tube	1	
	2791912	<b>HYDRAULIC DIAGRAM - CM2033</b>	Ref.	B
	2791913	<b>HYDRAULIC DIAGRAM - CM2046 AND CM2558</b>	Ref.	B
—305	1320030	Clamp	4	
—320	2220850	Fitting, Swivel	2	
	7012594	O-Ring Kit (1 per Fitting)	2	
—321	2220851	Fitting, Swivel	2	
	7012594	O-Ring Kit (1 per Fitting)	2	
—333	4640128	Valve	1	
—347	0100011	Loctite #242	A/R	

**SECTION 11 - 6 HYDRAULICS**

**SECTION 11-7 ELECTRICAL  
CM2033/CM2046/CM2546/CM2558**



**TABLE OF CONTENTS**

FIGURE NO.	DESCRIPTION	PAGE NO.
11-7-1	Electrical Diagrams and Components Chart.....	11-7-2
11-7-2	Electrical Diagram - Toggle Switch Drive (Euro except French Spec) .....	11-7-10
11-7-3	Electrical Diagram - Toggle Switch Drive (Australian Spec).....	11-7-11
11-7-4	Electrical Diagram -Toggle Switch Drive (French Spec).....	11-7-12
11-7-5	Electrical Diagram - PQ Controller Bang-Bang Drive (Euro except French Spec)	11-7-13
11-7-6	Electrical Diagram - PQ Controller Bang-Bang Drive (Australian Spec) .....	11-7-14
11-7-7	Electrical Diagram - PQ Controller Bang-Bang Drive (French Spec).....	11-7-15
11-7-8	Electrical Diagram - PQ Controller Proportional Drive (Euro except French Spec)	11-7-16
11-7-9	Electrical Diagram - PQ Controller Proportional Drive (Australian Spec).....	11-7-17
11-7-9A	Electrical Diagram - PQ Controller Proportional Drive (French Spec) .....	11-7-18
11-7-10	Electrical Diagram - Circuit Cards.....	11-7-19
11-7-11	Main Electrical Connector and Tools.....	11-7-20

**S  
E  
C  
T  
I  
O  
N  
  
1  
1  
-  
7  
  
E  
L  
E  
C  
T  
R  
I  
C  
A  
L**

# SECTION 11-7 ELECTRICAL

## CM2033/CM2046/CM2546/CM2558



SECTION 11-7 ELECTRICAL

FIGURE & ITEM NO	PART NUMBER	DESCRIPTION	QTY.	REV.
11—7—1		<b>ELECTRICAL DIAGRAMS AND COMPONENTS CHART</b> (Note: * Indicates Diagrams shown in the following pages. Diagrams not shown are available from JLG Service Department upon request.)	Ref.	
	1281570	<b>ALARMS ELECTRICAL DIAGRAM (DWG. ONLY)</b>	Ref.	E
	0251762	<b>ALARM ELECTRICAL DIAGRAM - DESCENT (B/M ONLY)</b>	Ref.	B
	0251761	<b>ALARM ELECTRICAL DIAGRAM - MOTION (TOGGLE SWITCH DRIVE) (B/M ONLY)</b>	Ref.	B
	0254268	<b>ALARM ELECTRICAL DIAGRAM - MOTION (PQ BANG-BANG DRIVE) (B/M ONLY)</b>	Ref.	—
	0251760	<b>ALARM ELECTRICAL DIAGRAM - TRAVEL (TOGGLE SWITCH DRIVE) (B/M ONLY)</b>	Ref.	B
	0254267	<b>ALARM ELECTRICAL DIAGRAM - TRAVEL (PQ BANG-BANG DRIVE) (B/M ONLY)</b>	Ref.	—
	0140033	Alarm, Motion	1	
	3990010	Diode - 6 Amp	A/R	
	0251758	<b>BATTERY/HOUR GAUGE ELECTRICAL DIAGRAM (STEEL CONSOLE BOX)</b>	Ref.	B
	0253499	<b>BATTERY/HOUR GAUGE ELECTRICAL DIAGRAM (MOLDED CONSOLE BOX)</b>	Ref.	A
	2420106	Gauge, Battery/Hour	1	
	0252274	<b>BEACON LIGHT ELECTRICAL DIAGRAM (FRAME MOUNTED)</b>	Ref.	A
	2920087	Light Beacon	1	
	1060341	Cable, Electrical - 16/2	6 ft./1.8m	
	0251870	<b>BEACON LIGHT ELECTRICAL DIAGRAM (PLATFORM MOUNTED LIGHT/STEEL CONSOLE BOX)</b>	Ref.	B
	2920092	Light Beacon	1	
	1060341	Cable, Electrical	16 ft./5m	
	4460049	Connector, Strain Relief (Located at Console Box)	1	
	3300047	Locknut, Conduit (Located at Console Box)	1	
	0960239	Bushing (Located at Console Box)	1	
	1281952	<b>BEACON LIGHT ELECTRICAL DIAGRAM (PLATFORM MOUNTED LIGHT/MOLDED CONSOLE BOX (DWG ONLY)</b>	Ref.	—
	0253476	<b>BEACON LIGHT ELECTRICAL DIAGRAM -STANDARD CM2033 AND CM2046 (B/M ONLY)</b>	Ref.	A
	0253478	<b>BEACON LIGHT ELECTRICAL DIAGRAM -STANDARD CM2546 and CM2558 (B/M ONLY)</b>	Ref.	—
	2920087	Light, Beacon - Standard	1	
	1060341	Cable, Electrical - 16/2 CM2033 and CM2046 CM2546 and CM2558	A/R 54 ft./16.5m 62 ft./19m	



# SECTION 11-7 ELECTRICAL

## CM2033/CM2046/CM2546/CM2558



FIGURE & ITEM NO	PART NUMBER	DESCRIPTION	QTY.	REV.
11—7—1		<b>ELECTRICAL DIAGRAMS AND COMPONENTS CHART (CONTINUED)</b>	Ref.	
		<b>CIRCUIT CARD ELECTRICAL DIAGRAM (ENABLE)</b>	Ref.	
	0610101	Prior to January 1995	Ref.	
	0610113*	January 1995 to Present	Ref.	
	0610105	<b>CIRCUIT CARD ELECTRICAL DIAGRAM (RELAY)</b>	Ref.	
	1281645	<b>DRIVE CUTOUT ELECTRICAL DIAGRAM (STEEL CONSOLE BOX) (DWG ONLY)</b>	Ref.	E
	0251723	<b>DRIVE CUTOUT ELECTRICAL DIAGRAM (STEEL CONSOLE BOX) (B/M ONLY)</b>	Ref.	—
	0252387	<b>DRIVE CUTOUT ELECTRICAL DIAGRAM (ITALIAN SPEC WITH STEEL CONSOLE BOX (B/M ONLY)</b>	Ref.	—
	1281950	<b>DRIVE CUTOUT ELECTRICAL DIAGRAM (MOLDED CONSOLE BOX) (DWG ONLY)</b>	Ref.	F
	0253490	<b>DRIVE CUOTUT ELECTRICAL DIAGRAM (EURO SPEC EXCEPT ITALIAN WITH MOLDED CONSOLE BOX) (B/M ONLY)</b>	Ref.	A
	0253492	<b>DRIVE CUTOUT ELECTRICAL DIAGRAM (ITALIAN SPECS WITH MOLDED CONSOLE BOX) (B/M ONLY)</b>	Ref.	A
	4360300	Switch, Limit	1	
	4360349	Sensor, Level - 2.5°	1	
	7012608	Fuse - 1.5 Amp (Black Sensor/Not Required on Orange or Blue Sensor)	A/R	
	0255703	<b>HIGH SPEED DISCONNECT ELECTRICAL DIAGRAM</b>	Ref.	—
	0251788	<b>HORN ELECTRICAL DIAGRAM (STEEL CONSOLE BOX)</b>	Ref.	B
	0253465	<b>HORN ELECTRICAL DIAGRAM (MOLDED CONSOLE BOX)</b>	Ref.	A
	0140022	Horn	1	
	4360274	Switch, Push Button	1	
	1060341	Cable, Electrical - 16/2	8 ft./2.4m	
	0251705	<b>PLATFORM EXTENSION INTERLOCK ELECTRICAL DIAGRAM (STEEL CONSOLE BOX) (ALL FRENCH SPECS AND ITALIAN SPECS PRIOR TO AUGUST 1993)</b>	Ref.	B
	1281993	<b>PLATFORM EXTENSION INTERLOCK ELECTRICAL DIAGRAM (MOLDED CONSOLE BOX) (ALL FRENCH SPECS AND ITALIAN SPECS PRIOR TO AUGUST 1993) (DWG ONLY)</b>	Ref.	D
	0253616	<b>PLATFORM EXTENSION INTERLOCK ELECTRICAL DIAGRAM (MOLDED CONSOLE BOX) (B/M ONLY)</b>	Ref.	B
	4360277	Switch, Limit	1	
	1060341	Cable, Electrical - 16/2	A/R	

**SECTION 11-7 ELECTRICAL**

# SECTION 11-7 ELECTRICAL

## CM2033/CM2046/CM2546/CM2558



SECTION 11-7 ELECTRICAL

FIGURE & ITEM NO	PART NUMBER	DESCRIPTION	QTY.	REV.
11-7-1		<b>ELECTRICAL DIAGRAMS AND COMPONENTS CHART (CONTINUED)</b>	Ref.	
	1282149	<b>PLATFORM EXTENSION INTERLOCK ELECTRICAL DIAGRAM (MOLDED CONSOLE BOX) (ITALIAN SPECS AUGUST 1993 TO PRESENT)</b>	Ref.	B
	0254320	<b>PLATFORM EXTENSION INTERLOCK ELECTRICAL DIAGRAM - CM2033/CM2046 (B/M ONLY)</b>	Ref.	B
	0254321	<b>PLATFORM EXTENSION INTERLOCK ELECTRICAL DIAGRAM - CM2546/CM2558 (B/M ONLY)</b>	Ref.	B
	4360277	Switch, Limit	1	
	1060341	Cable, Electrical - 16/2	A/R	
	1060079	Cable, Electrical - 16/4	7 ft./2m	
	3740069	Relay	1	
	0239709/9983590	<b>PLATFORM WORKLIGHTS ELECTRICAL DIAGRAM (MACHINES WITH STEEL CONSOLE BOX)</b>	Ref.	—/—
	1281951	<b>PLATFORM WORKLIGHTS ELECTRICAL DIAGRAM (MACHINES WITH MOLDED CONSOLE BOX)(DWG ONLY)</b>	Ref.	A
	0253504	<b>PLATFORM WORKLIGHTS ELECTRICAL DIAGRAM (CM2033/CM2046 WITH MOLDED CONSOLE BOX) (B/M ONLY)</b>	Ref.	—
	0253506	<b>PLATFORM WORKLIGHTS ELECTRICAL DIAGRAM (CM2546/CM2558 WITH MOLDED CONSOLE BOX) (B/M ONLY)</b>	Ref.	
	2920088	Worklight (Machines with Steel Console Box)	2	
	2920093	Worklight (Machines with Molded Console Box)	2	
	1060341	Cable, Electrical - 16/2 (Molded Console Box Only)	A/R	
		CM2033/CM2046	54ft/16.5m	
		CM2546/CM2558	62ft/19m	
		<b>STANDARD "GROUND TO PLATFORM" CABLE/HARNESS WITH STEEL CONSOLE BOX:</b>	Ref.	
	1060408	CM2033/CM2046 Standard Euro Spec(16/18 Cable)	46ft/15.2m	
	1060408	CM2546/CM2558 Standard Euro Spec(16/18 Cable)	54ft/16.5m	
	1060039	CM2033/CM2046 French Spec (16/24 Cable)	46ft/15.2m	
	1060039	CM2546/CM2558 French Spec (16/24 Cable)	54ft/16.5m	
		<b>WITH STEEL CONSOLE BOX:</b>	Ref.	
	4921516	CM2033/CM2046 Standard Euro Spec	1	
	4921517	CM2546/CM2558 Standard Euro Spec	1	
	4921519	CM2033/CM2046 French Spec	1	
	4921520	CM2546/CM2558 French Spec	1	
	1281559	<b>STANDARD ELECTRICAL DIAGRAM -TOGGLE SWITCH DRIVE/STEEL CONSOLE BOX/STANDARD EURO EXCEPT FRENCH SPEC MACHINES (DWG. ONLY)</b>	Ref.	C
	4932365	<b>Ground Components (B/M Only)</b>	Ref.	A
	4932372	<b>Platform Components (B/M Only)</b>	Ref.	B
	4921369	Valve and Ground Control Harness	Ref.	A
	4460277	Strip, Terminal - 14 Position	1	
	4460007	Strip, Terminal - 6 Position	1	
	3990010	Diode - 6 Amp	7	
	1060341	Cable, Electrical - 16/2 (To Cutout Switches)	16ft/4.9m	

# SECTION 11-7 ELECTRICAL

## CM2033/CM2046/CM2546/CM2558



FIGURE & ITEM NO	PART NUMBER	DESCRIPTION	QTY.	REV.
11-7-1		<b>ELECTRICAL DIAGRAMS AND COMPONENTS CHART (CONTINUED)</b>	Ref.	
	1281882*	<b>STANDARD ELECTRICAL DIAGRAM -TOGGLE SWITCH DRIVE/MOLDED CONSOLE BOX/STANDARD EURO EXCEPT FRENCH SPEC MACHINES (DWG. ONLY)</b>	Ref.	E
	4932526	<b>Ground Components (B/M Only)</b>	Ref.	A
	4932527	<b>Platform Components (B/M Only)</b>	Ref.	A
	4921454	Valve and Ground Control Harness	Ref.	—
	4460277	Strip, Terminal - 14 Position	1	
	4460007	Strip, Terminal - 6 Position	1	
	3990010	Diode - 6 Amp	7	
	1060341	Cable, Electrical - 16/2 (To Cutout Switches)	30FT/9M	
	1282024*	<b>STANDARD ELECTRICAL DIAGRAM -TOGGLE SWITCH DRIVE/MOLDED CONSOLE BOX/AUSTRALIAN EURO MACHINES (DWG. ONLY)</b>	Ref.	C
	4932609	<b>Ground Components (B/M Only)</b>	Ref.	A
	4932536	<b>Platform Components (B/M Only)</b>	Ref.	B
	4921537	Valve and Ground Control Harness	Ref.	—
	4460277	Strip, Terminal - 14 Position	1	
	4460264	Strip, Terminal	1	
	4460007	Strip, Terminal - 6 Position	1	
	3740069	Relay	1	
	3990010	Diode - 6 Amp	12	
	1060341	Cable, Electrical - 16/2 (To Cutout Switches)	30FT/9M	
	1281725	<b>STANDARD ELECTRICAL DIAGRAM -TOGGLE SWITCH DRIVE/STEEL CONSOLE BOX/FRENCH SPEC MACHINES (DWG. ONLY)</b>	Ref.	A
	4932445	<b>Ground Components (B/M Only)</b>	Ref.	—
	4932447	<b>Platform Components (B/M Only)</b>	Ref.	—
	4921393	Valve and Ground Control Harness	Ref.	A
	4460277	Strip, Terminal - 14 Position	1	
	4460007	Strip, Terminal - 6 Position	1	
	3990010	Diode - 6 Amp	9	
	3740069	Relay	3	
	1060341	Cable, Electrical - 16/2 (To Cutout Switches/To Lift Down Solenoid)	44ft/13.4m	
	1281885*	<b>STANDARD ELECTRICAL DIAGRAM -TOGGLE SWITCH DRIVE/MOLDED CONSOLE BOX/FRENCH SPEC MACHINES (DWG. ONLY)</b>	Ref.	D
	4932535	<b>Ground Components (B/M Only)</b>	Ref.	A
	4932536	<b>Platform Components (B/M Only)</b>	Ref.	A
	4921466	Valve and Ground Control Harness	Ref.	—
	4460277	Strip, Terminal - 14 Position	1	
	4460007	Strip, Terminal - 6 Position	1	
	3990010	Diode - 6 Amp	9	
	3740069	Relay	3	
	1060341	Cable, Electrical - 16/2 (To Cutout Switches)	30FT/9M	

SECTION 11-7 ELECTRICAL

# SECTION 11-7 ELECTRICAL

## CM2033/CM2046/CM2546/CM2558



SECTION 11-7 ELECTRICAL

FIGURE & ITEM NO	PART NUMBER	DESCRIPTION	QTY.	REV.
11—7—1		<b>ELECTRICAL DIAGRAMS AND COMPONENTS CHART (CONTINUED)</b>	Ref.	
	1281560	<b>STANDARD ELECTRICAL DIAGRAM - PQ BANG-BANG DRIVE/STEEL CONSOLE BOX/STANDARD EURO EXCEPT FRENCH SPEC MACHINE (DWG ONLY)</b>	Ref.	D
	4932366	<b>Ground Components (B/M Only)</b>	Ref.	A
	4932373	<b>Platform Components (B/M Only)</b>	Ref.	—
	4921366	Valve and Ground Control Harness	1	A
	4460277	Strip, Terminal - 14 Position	1	
	4460007	Strip, Terminal - 6 Position	1	
	3990010	Diode - 6 Amp	6	
	3740069	Relay	3	
	1060341	Cable, Electrical - 16/2 (To Cutout Switch/To Lift Down Solenoid)	16 ft./4.9m	
	4921308	PQ Controller Harness	1	
	1281883*	<b>STANDARD ELECTRICAL DIAGRAM PQ BANG-BANG DRIVE/MOLDED CONSOLE BOX/STANDARD EURO EXCEPT FRENCH SPEC MACHINE (DWG ONLY)</b>	Ref.	D
	4932529	<b>Ground Components (B/M Only)</b>	Ref.	A
	4932530	<b>Platform Components (B/M Only)</b>	Ref.	—
	4921462	Valve and Ground Control Harness	1	—
	4460277	Strip, Terminal - 14 Position	1	
	4460007	Strip, Terminal - 6 Position	1	
	3990010	Diode - 6 Amp	6	
	3740069	Relay	2	
	1060341	Cable, Electrical - 16/2 (To Cutout Switches/To Lift Down Solenoid)	30 ft./9m	
	1282186*	<b>STANDARD ELECTRICAL DIAGRAM (PQ BANG-BANG DRIVE/MOLDED CONSOLE BOX - AUSTRALIAN SPEC) (DWG ONLY)</b>	Ref.	C
	4932688	<b>Ground Components (B/M Only)</b>	Ref.	A
	4932530	<b>Platform Components (B/M Only)</b>	Ref.	—
	4921660	Valve and Ground Control Harness	1	A
	4460277	Strip, Terminal - 14 Position	1	
	4460264	Strip, Terminal	1	
	4460007	Strip, Terminal - 6 Position	1	
	3990010	Diode - 6 Amp	12	
	3740069	Relay - 24 VDC	3	
	1060341	Cable, Electrical - 16/2 (To Cutout Switches/to Limit Switches)	38 ft./11.6m	
	1281726	<b>STANDARD ELECTRICAL DIAGRAM - PQ BANG-BANG DRIVE/STEEL CONSOLE BOX/FRENCH SPEC MACHINE (DWG ONLY)</b>	Ref.	A
	4932446	Ground Components (B/M Only)	Ref.	—
	4932448	Platform Components (B/M Only)	Ref.	—

# SECTION 11-7 ELECTRICAL

## CM2033/CM2046/CM2546/CM2558



FIGURE & ITEM NO	PART NUMBER	DESCRIPTION	QTY.	REV.
11-7-1		<b>ELECTRICAL DIAGRAMS AND COMPONENTS CHART (CONTINUED)</b>	Ref.	
	4921394	Valve and Ground Control Harness	1	A
	4460277	Strip, Terminal - 14 Position	1	
	4460007	Strip, Terminal - 6 Position	1	
	3990010	Diode - 6 Amp	9	
	3740069	Relay	5	
	1060341	Cable, Electrical - 16/2 (To Cutout Switch/To Lift Down Solenoid)	24 ft./7.3m	
	1060300	Cable, Electrical - 16/3 (To Level Sensor)	6 ft./1.8m	
	3990010	Diode - 6 Amp (Platform)	6	
	4921308	PQ Controller Harness	1	
	1281886*	<b>STANDARD ELECTRICAL DIAGRAM - PQ BANG-BANG DRIVE/MOLDED CONSOLE BOX/FRENCH SPEC MACHINE (DWG ONLY)</b>	Ref.	E
	4932538	Ground Components (B/M Only)	Ref.	A
	4932539	Platform Components (B/M Only)	Ref.	—
	4921468	Valve and Ground Control Harness	1	—
	4460277	Strip, Terminal - 14 Position	1	
	4460007	Strip, Terminal - 6 Position	1	
	3990010	Diode - 6 Amp	6	
	3760069	Relay	5	
	1060341	Cable, Electrical - 16/2 (To Cutout Switch/To Lift Down Solenoid)	44 ft./13.4m	
	1281782	<b>STANDARD ELECTRICAL DIAGRAM - PQ PROPORTIONAL DRIVE/STEEL CONSOLE BOX/STANDARD EURO EXCEPT FRENCH SPEC MACHINE (DWG ONLY)</b>	Ref.	B
	4932478	Ground Components (B/M Only)	Ref.	—
	4932476	Platform Components (B/M Only)	Ref.	A
	4921409	Valve and Ground Control Harness	1	—
	4460277	Strip, Terminal - 14 Position	1	
	4460007	Strip, Terminal - 6 Position	1	
	3990010	Diode - 6 Amp	4	
	3760069	Relay	1	
	1060341	Cable, Electrical - 16/2 (To Cutout Switch/To Lift Down Solenoid)	16 ft./4.9m	
	4921413	PQ Controller Harness	1	
	3990010	Diode - 6 Amp (Platform)	1	
	1281884*	<b>STANDARD ELECTRICAL DIAGRAM - PQ PROPORTIONAL DRIVE/MOLDED CONSOLE BOX/STANDARD EURO MACHINE EXCEPT AUSTRALIAN AND FRENCH SPEC MACHINES (DWG ONLY)</b>	Ref.	E
	4932532	Ground Components (B/M Only)	Ref.	A
	4932533	Platform Components (B/M Only)	Ref.	—
	4921464	Valve and Ground Control Harness	1	A
	4460277	Strip, Terminal - 14 Position	1	

SECTION 11-7 ELECTRICAL



# SECTION 11-7 ELECTRICAL

## CM2033/CM2046/CM2546/CM2558



FIGURE & ITEM NO	PART NUMBER	DESCRIPTION	QTY.	REV.
11—7—1		<b>ELECTRICAL DIAGRAMS AND COMPONENTS CHART (CONTINUED)</b>	Ref.	
	4460007	Strip, Terminal - 6 Position	1	
	3990010	Diode - 6 Amp	4	
	3760069	Relay	2	
	1060341	Cable, Electrical - 16/2 (To Cutout Switch/To Lift Down Solenoid)	30FT/9M	
	1282331	<b>STANDARD ELECTRICAL DIAGRAM - PQ PROPORTIONAL DRIVE/MOLDED CONSOLE BOX/AUSTRALIAN SPEC MACHINES (DWG ONLY)</b>	Ref.	B
	4932738	<b>Ground Components (B/M Only)</b>	Ref.	A
	4932533	<b>Platform Components (B/M Only)</b>	Ref.	—
	4921706	Valve and Ground Control Harness	1	—
	4460277	Strip, Terminal - 14 Position	1	
	4460007	Strip, Terminal - 6 Position	1	
	3990010	Diode - 6 Amp	8	
	3760069	Relay	3	
	1060341	Cable, Electrical - 16/2 (To Cutout Switch/To Lift Down Solenoid)	30FT/9M	
	1281887*	<b>STANDARD ELECTRICAL DIAGRAM - PQ PROPORTIONAL DRIVE/MOLDED CONSOLE BOX/FRENCH SPEC MACHINES (DWG ONLY)</b>	Ref.	E
	4932541	<b>Ground Components (B/M Only)</b>	Ref.	B
	4932542	<b>Platform Components (B/M Only)</b>	Ref.	—
	4921470	Valve and Ground Control Harness	1	A
	4460277	Strip, Terminal - 14 Position	1	
	4460007	Strip, Terminal - 6 Position	1	
	3990010	Diode - 6 Amp	7	
	3760069	Relay	5	
	1060341	Cable, Electrical - 16/2 (To Cutout Switch/To Lift Down Solenoid)	30FT/9M	
	3990010	Diode - 6 Amp (Platform)	1	

**SECTION 11-7 ELECTRICAL**





# SECTION 11-7 ELECTRICAL CM2033/CM2046/CM2546/CM2558

FIGURE 11-7-3. ELECTRICAL DIAGRAM - TOGGLE SWITCH DRIVE (AUSTRALIAN SPEC).

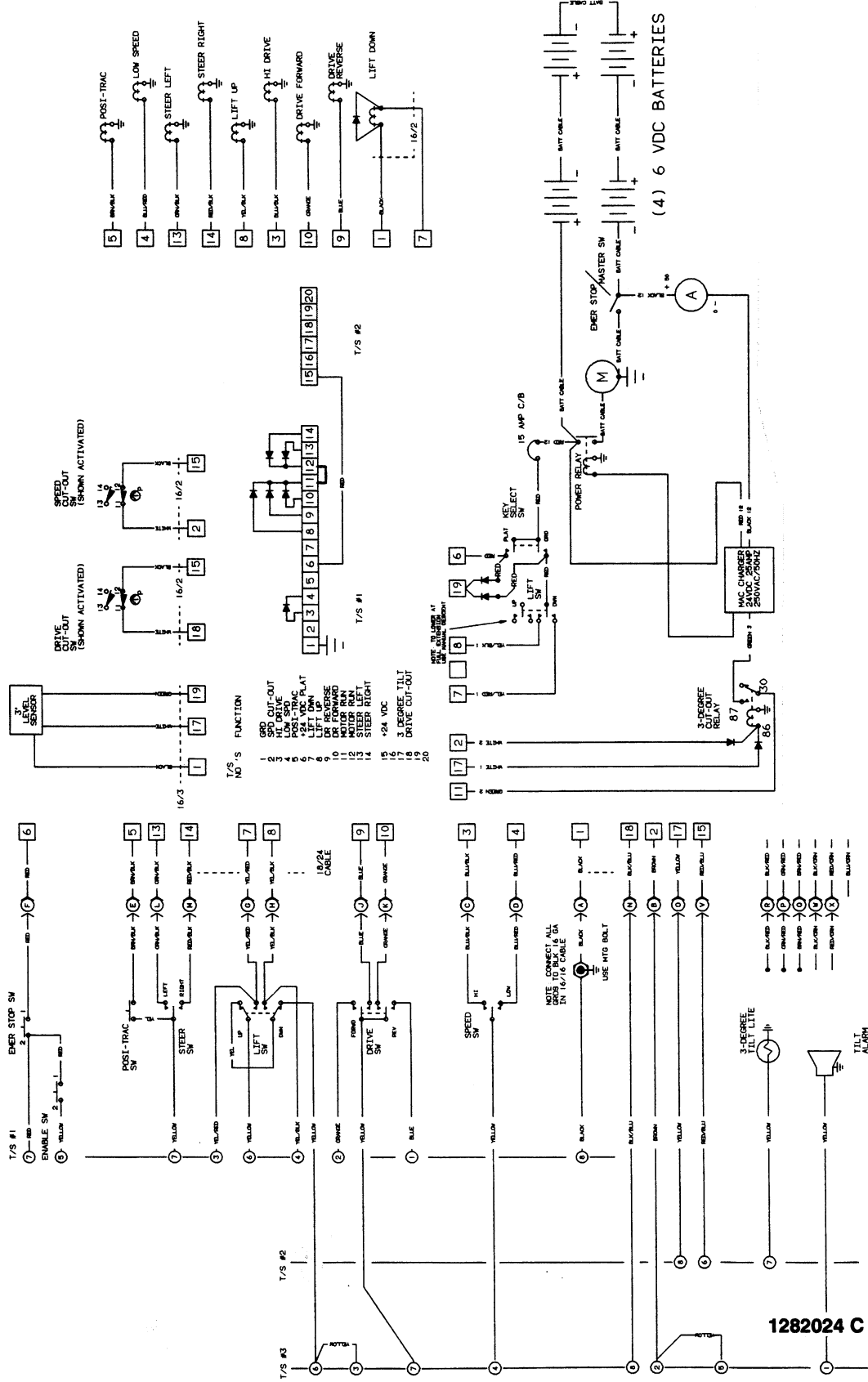

**EMERSON**  
**7-11**  
**NO-TIONS**

# ELECTRICAL SWITCHES

## SECTION 11-7 ELECTRICAL CM2033/CM2046/CM2546/CM2558

**FIGURE 11-7-4. ELECTRICAL DIAGRAM - TOGGLE SWITCH DRIVE (FRENCH SPEC).**

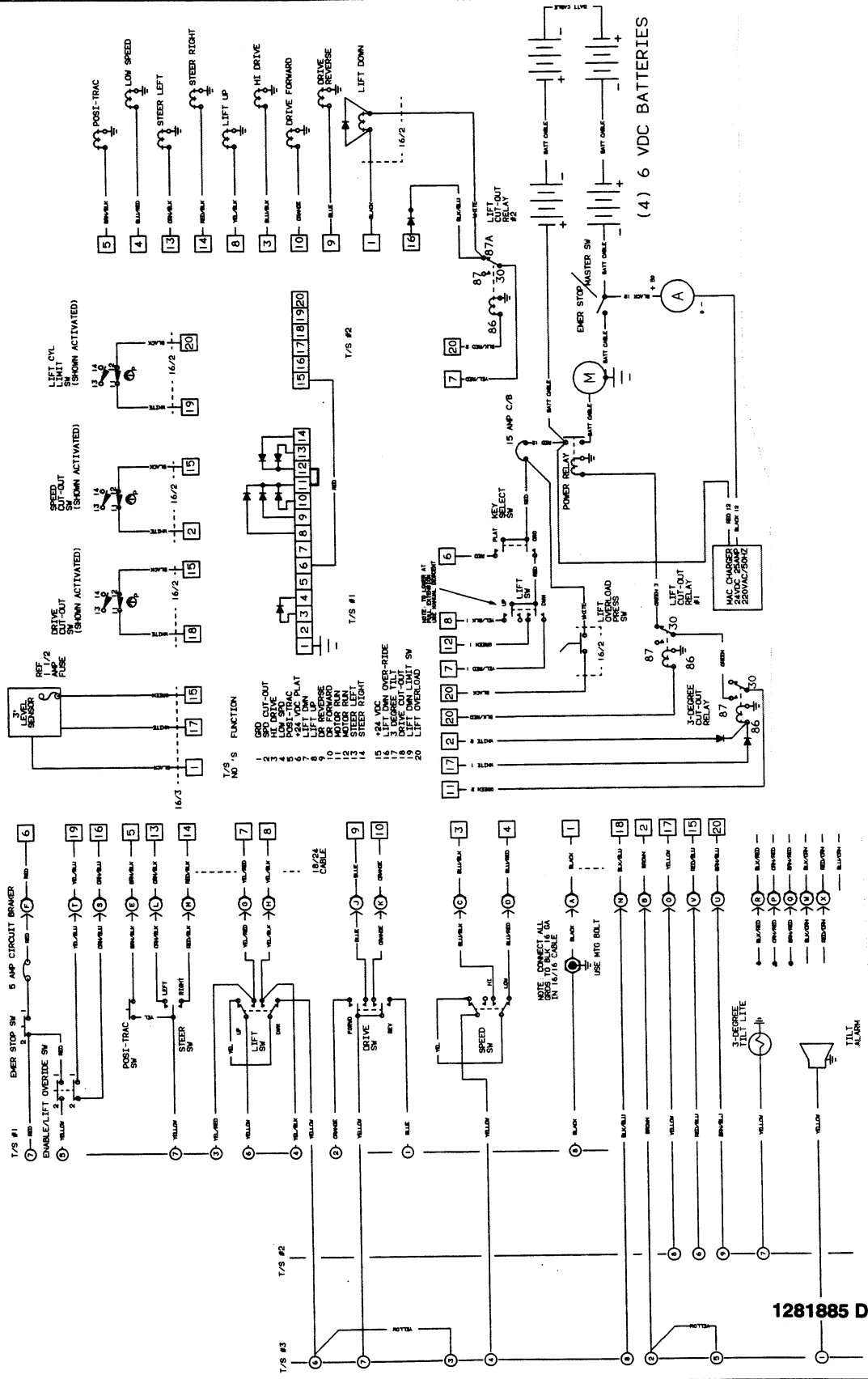

# SECTION 11-7 ELECTRICAL CM2033/CM2046/CM2546/CM2558



FIGURE 11-7-5. ELECTRICAL DIAGRAM - PQ CONTROLLER BANG-BANG DRIVE (EURO EXCEPT FRENCH & AUSTRALIAN SPECS).

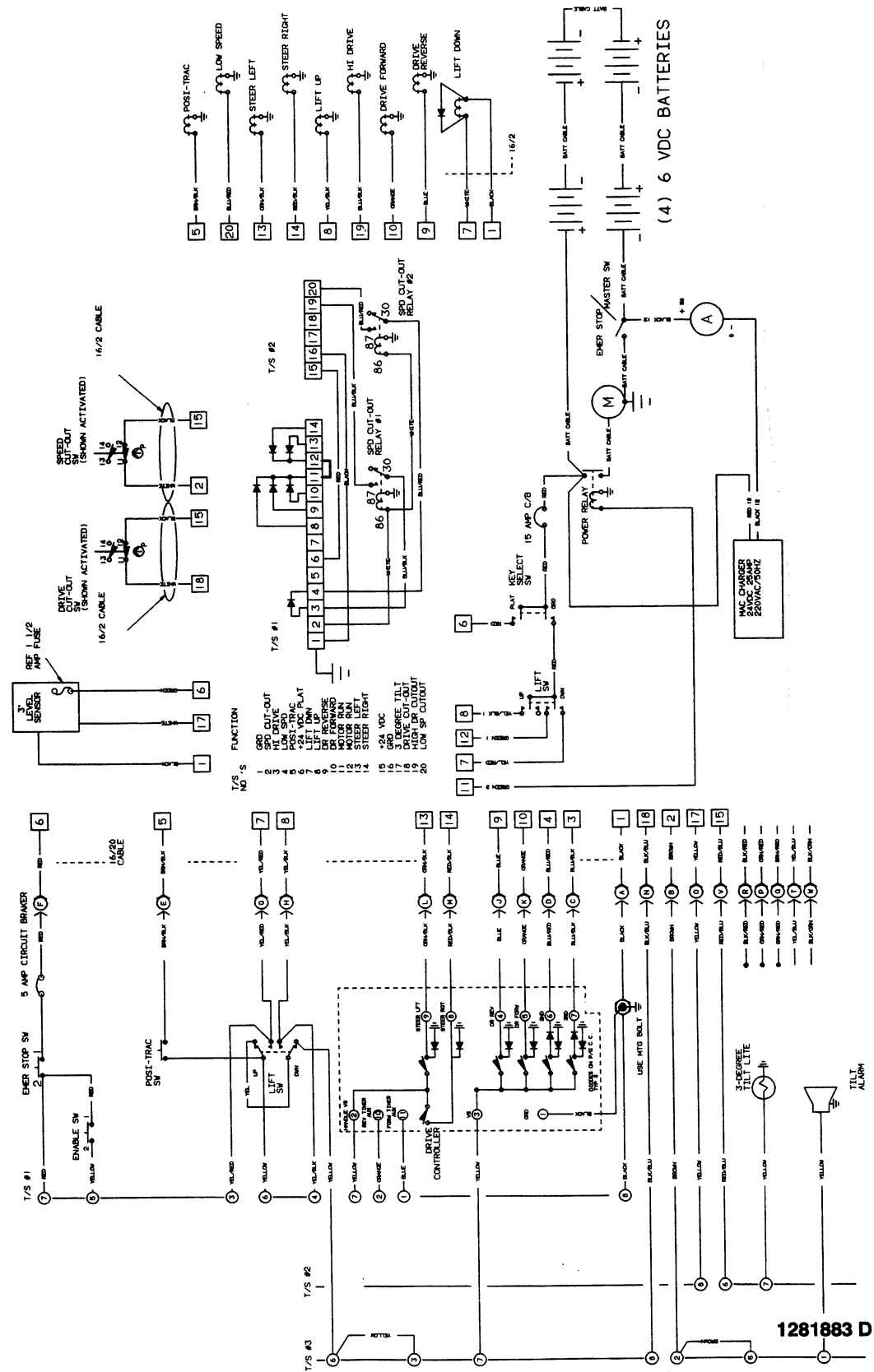

SECTION 11-7 ELECTRICAL

# SECTION 11-7 ELECTRICAL

## CM2033/CM2046/CM2546/CM2558

FIGURE 11-7-6. ELECTRICAL DIAGRAM - PQ CONTROLLER BANG-BANG DRIVE (AUSTRALIAN SPEC).

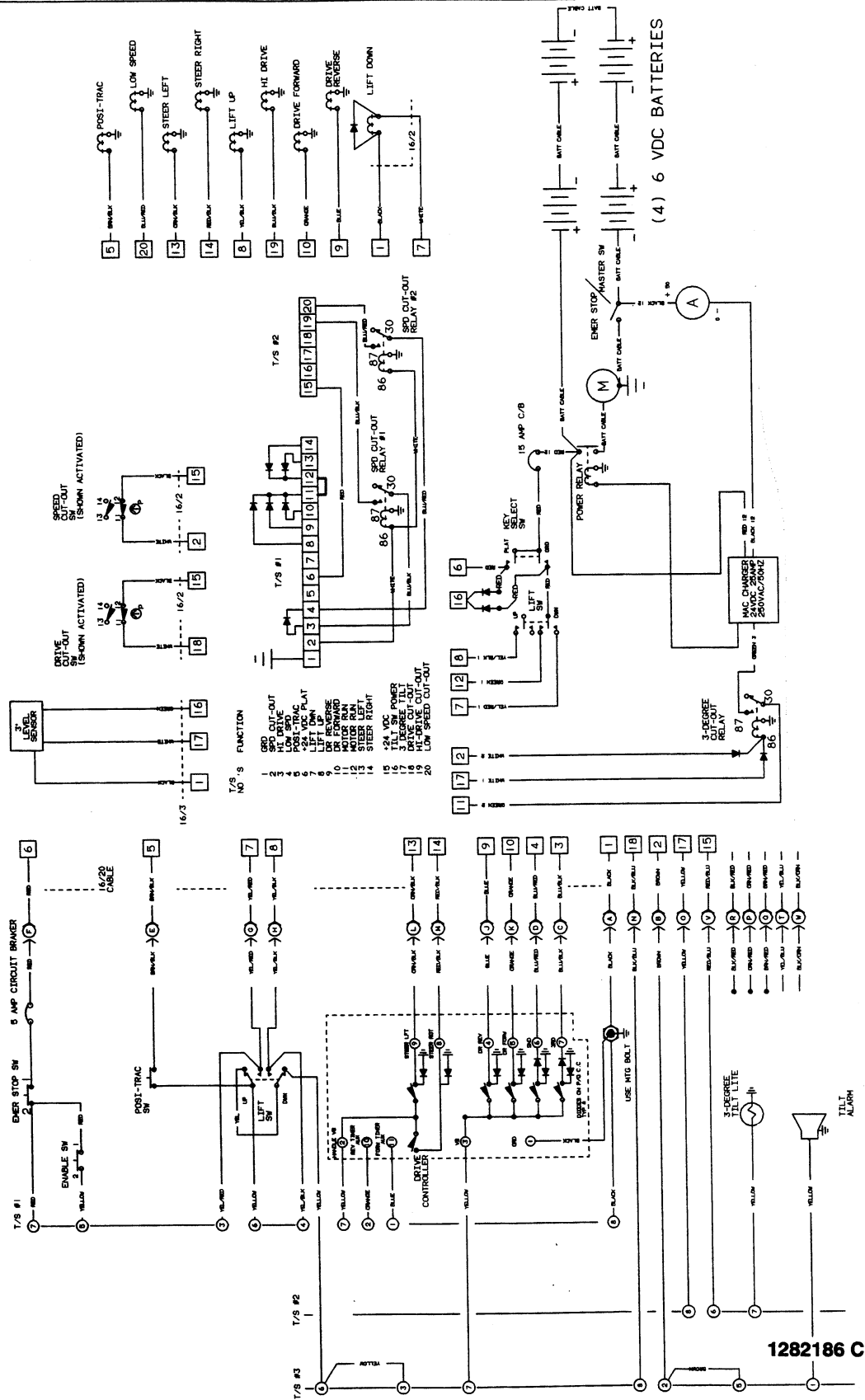

1282186 C



# SECTION 11-7 ELECTRICAL CM2033/CM2046/CM2546/CM2558

**FIGURE 11-7-8. ELECTRICAL DIAGRAM - PQ CONTROLLER PROP DRIVE (EURO EXCEPT FRENCH & AUSTRALIAN SPEC).**

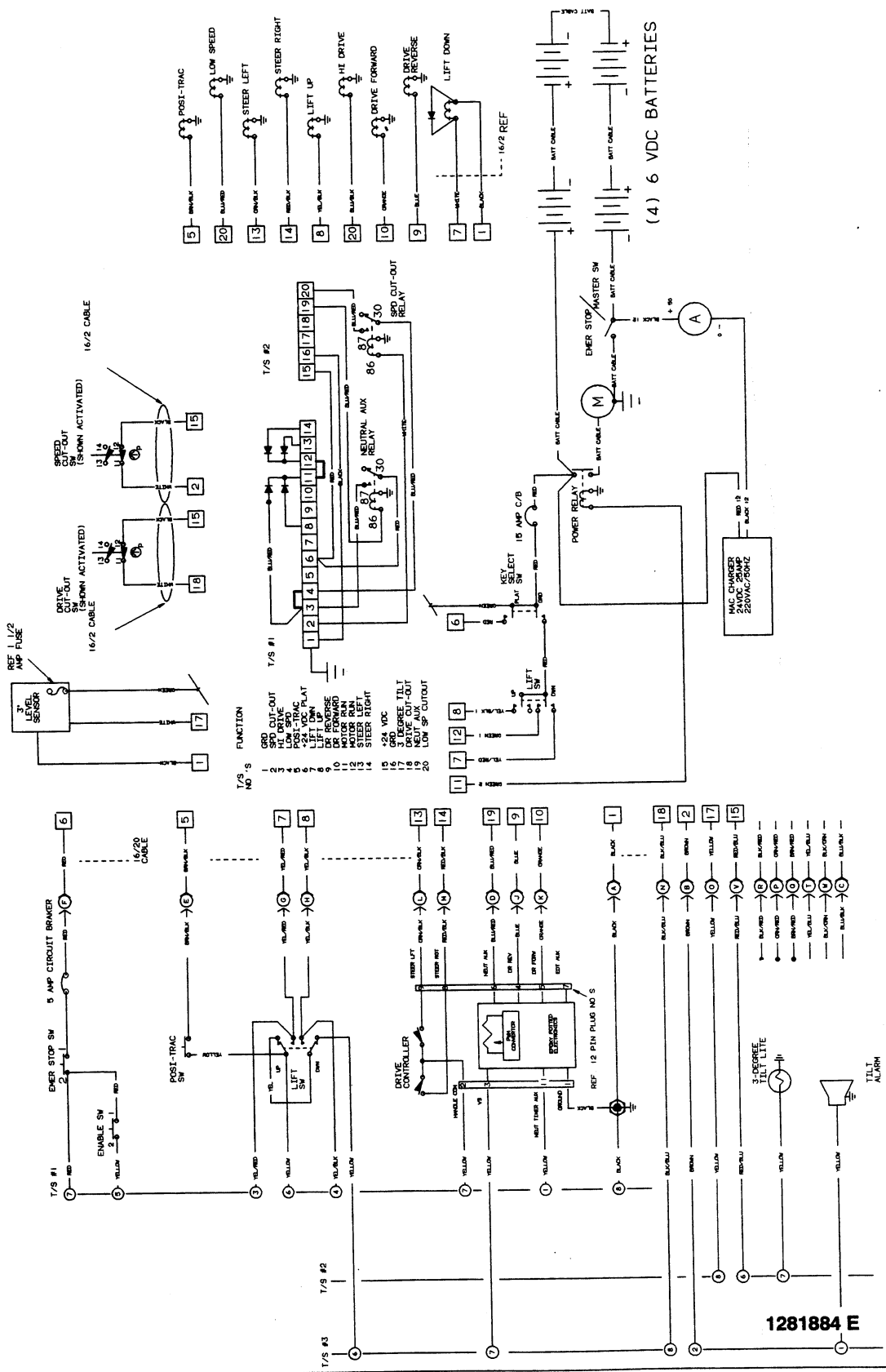

# SECTION 11-7 ELECTRICAL CM2033/CM2046/CM2546/CM2558

FIGURE 11-7-9. ELECTRICAL DIAGRAM - PQ CONTROLLER  
PROP DRIVE (AUSTRALIAN SPEC).

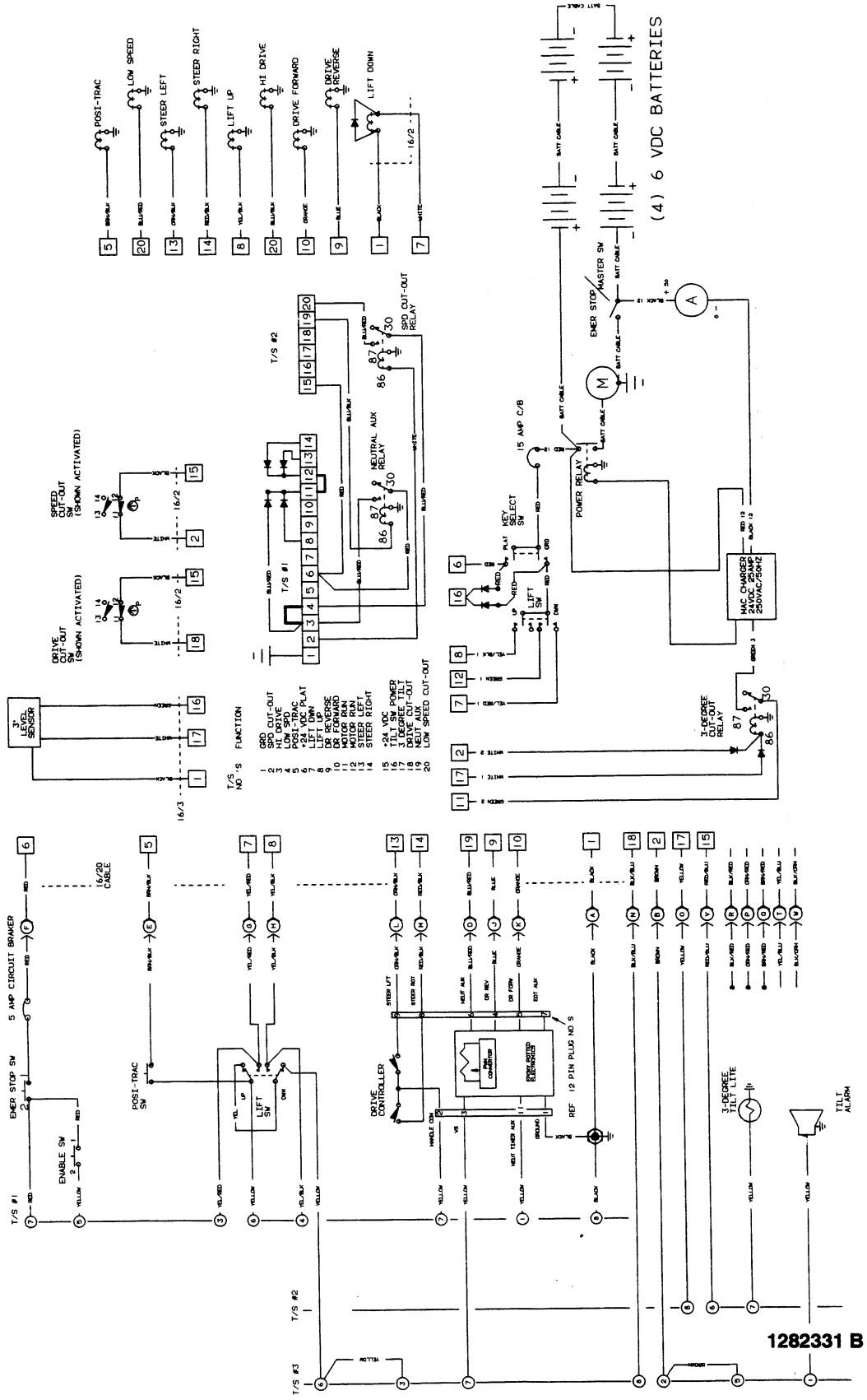

CALIBRATIONAL 11-7-11

1282331 B





# SECTION 11-7 ELECTRICAL CM2033/CM2046/CM2546/CM2558



FIGURE 11-7-10. ELECTRICAL DIAGRAM - CIRCUIT CARDS.

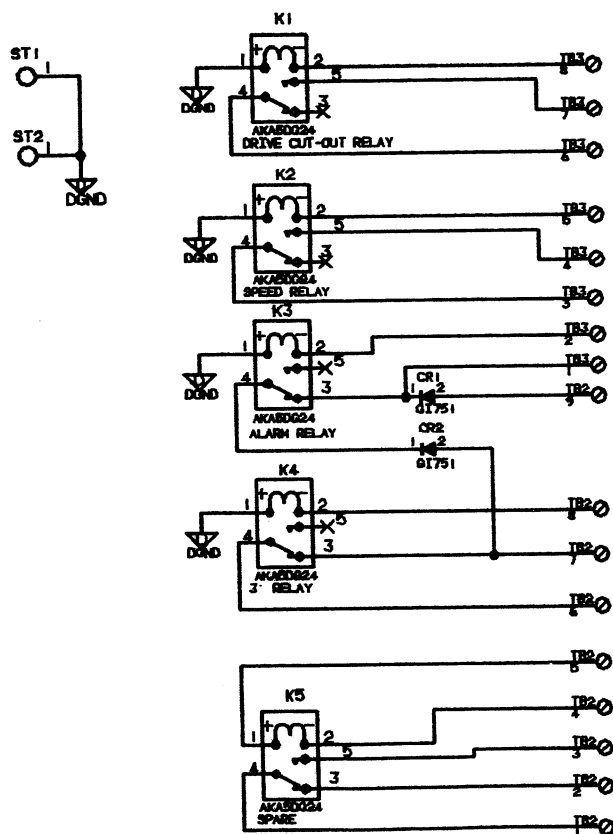
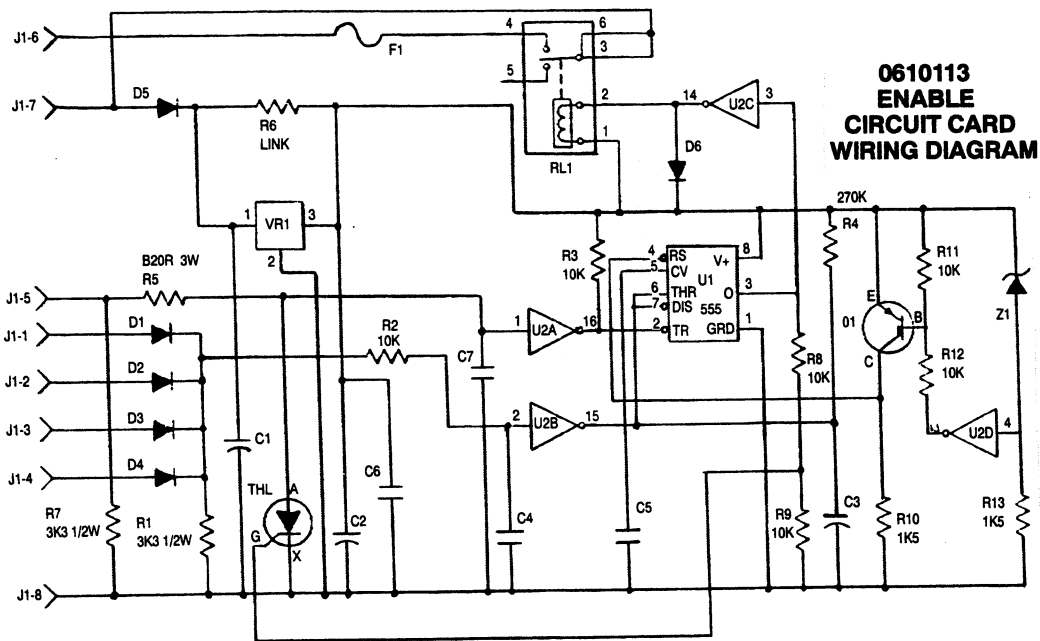

0610105  
RELAY  
CIRCUIT CARD  
WIRING DIAGRAM

SECTION 11-7 ELECTRICAL

# SECTION 11-7 ELECTRICAL CM2033/CM2046/CM2546/CM2558



FIGURE 11-7-11. MAIN ELECTRICAL CONNECTOR AND TOOLS.

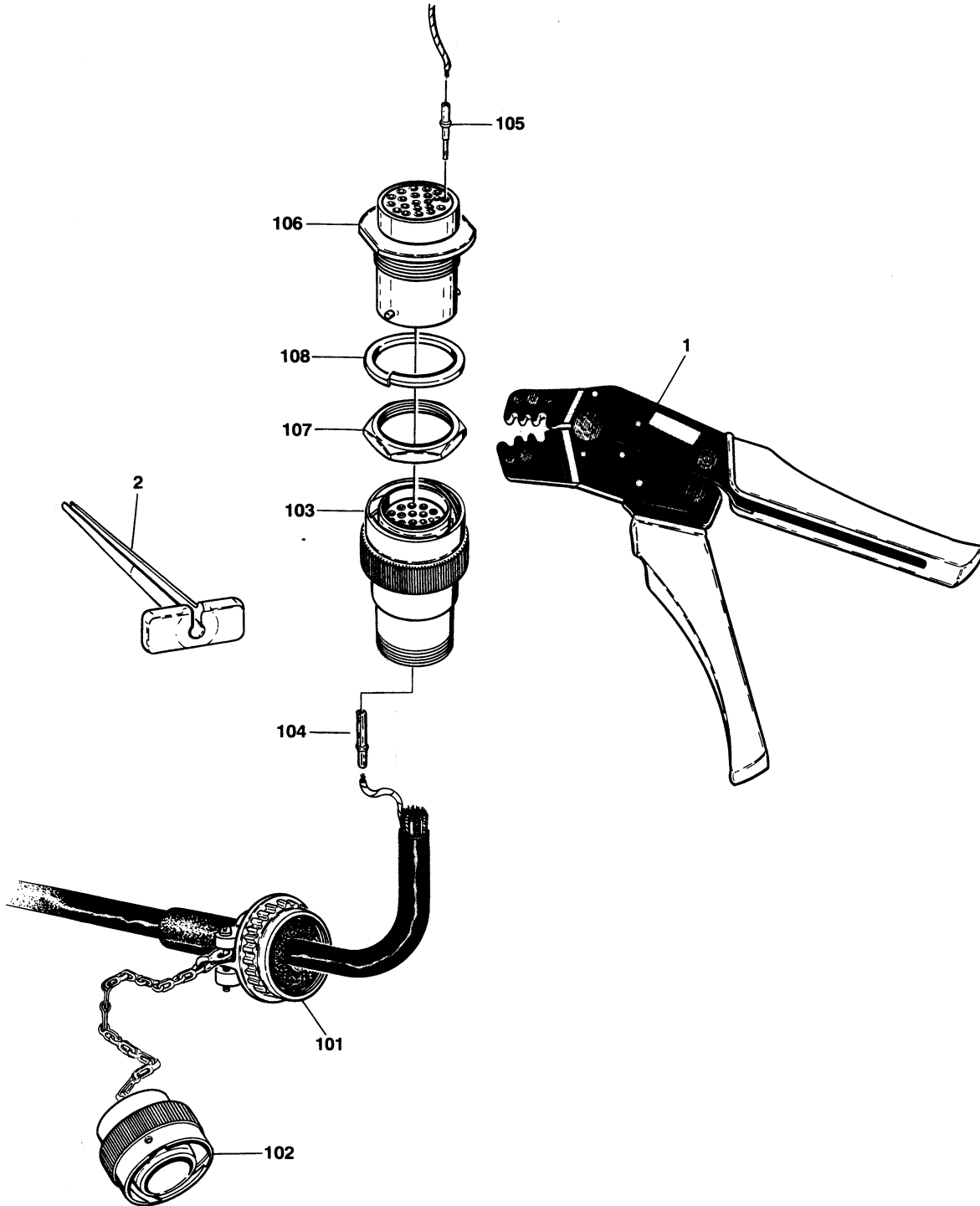

SECTION 11-7 ELECTRICAL

**SECTION 11-7 ELECTRICAL  
CM2033/CM2046/CM2546/CM2558**



FIGURE & ITEM NO	PART NUMBER	DESCRIPTION	QTY.	REV.
11—7—11		<b>MAIN ELECTRICAL CONNECTOR AND TOOLS</b>	Ref.	
		<b>Tools:</b>	Ref.	
—1	7002818	Crimper (For Wire to Pin/Socket Connections)	1	
—2	4460467	Extractor (For Removal of Pins/Sockets from Connectors)	1	
		<b>Connector Components:</b>	Ref.	
—101	4460473	Clamp, Cable	1	
—102	4460468	Cap, Dust	1	
—103	4460462	Plug, Connector - 23 Pin (Female)	1	
—104	4460465	Socket, Female	A/R	
—105	4460464	Pin, Male	A/R	
—106	4460463	Receptacle, Connector - 23 Pin (Male)	1	
—107	4460470	Nut, Receptacle	1	
—108	4460471	Lockwasher, Receptacle	1	

**SECTION 11 - 7 ELECTRICAL**



**SECTION 11-8 DECALS  
CM2033/CM2046/CM2546/CM2558**



**TABLE OF CONTENTS**

FIGURE NO.	TITLE	PAGE NO.
11-8-1	Decal Installation .....	11-8-2

**S  
E  
C  
T  
I  
O  
N  
  
1  
1  
-  
8  
  
D  
E  
C  
A  
L  
S**

# SECTION 11-8 DECALS CM2033/CM2046/CM2546/CM2558



FIGURE 11-8-1. DECALS INSTALLATION.

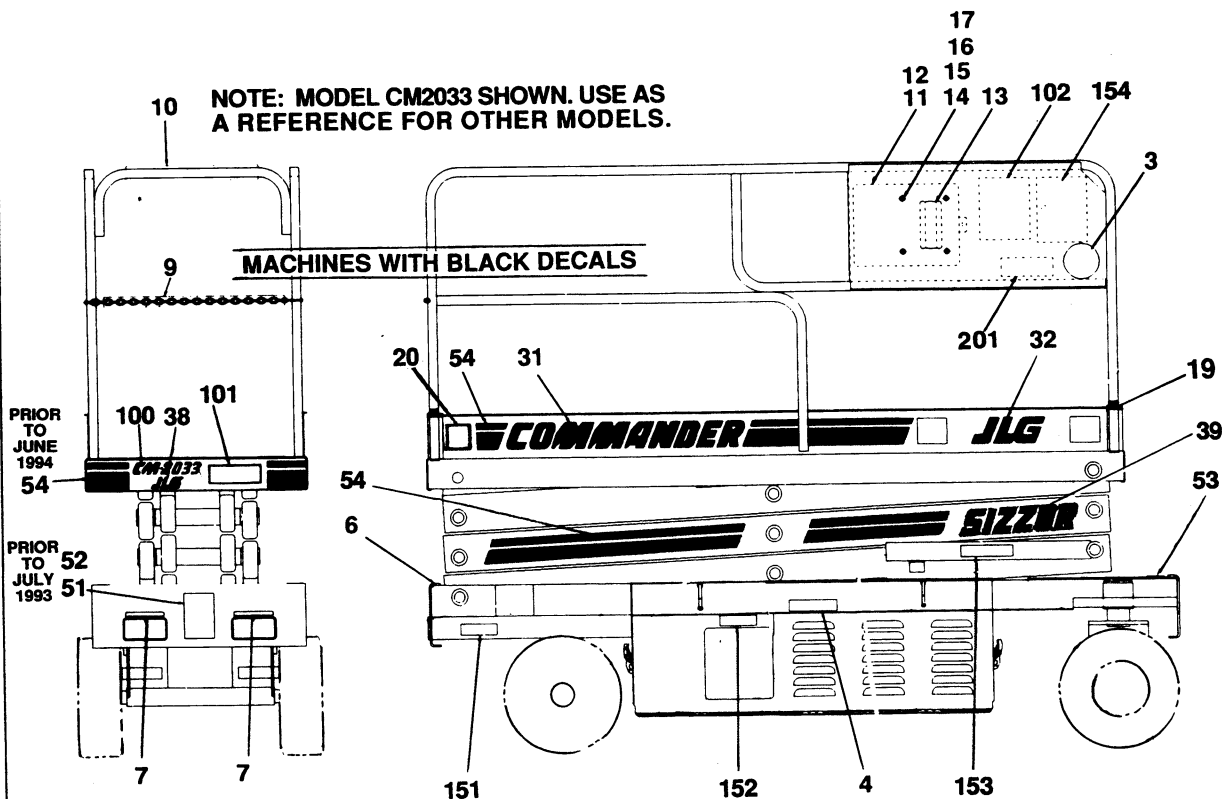
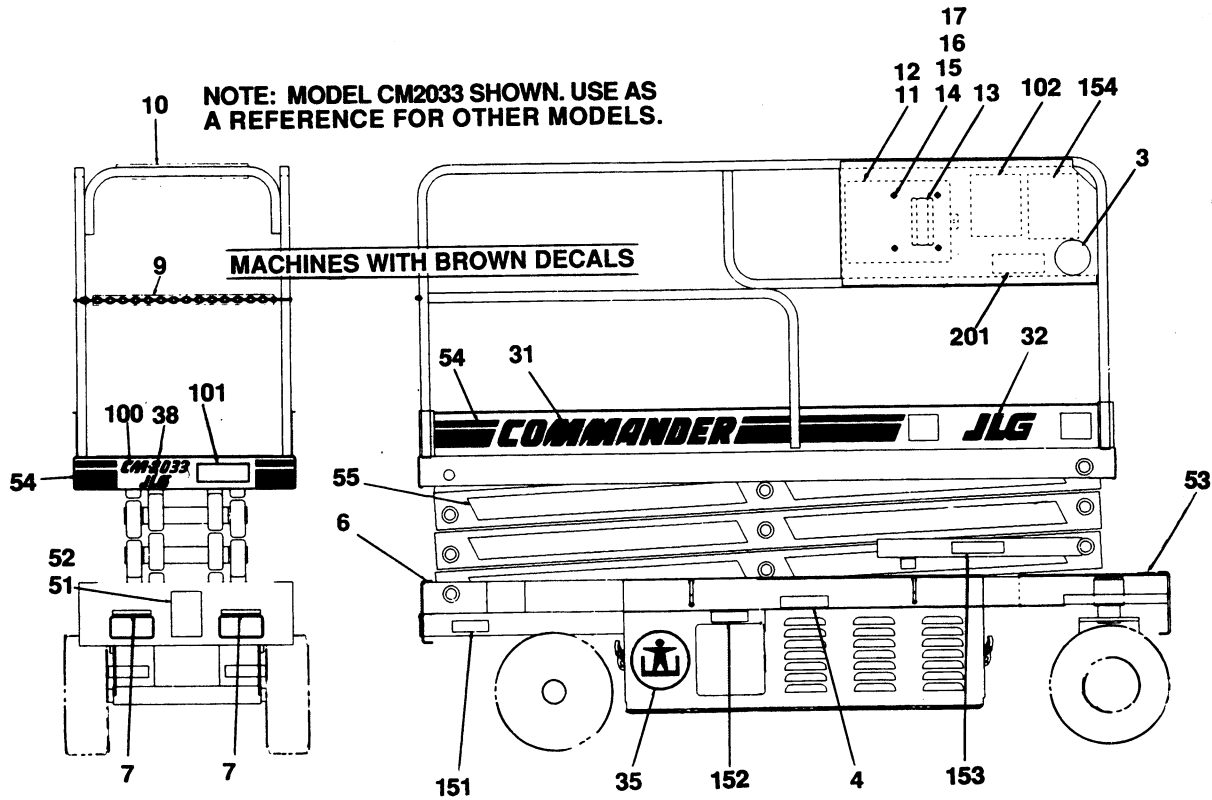

SECTION 11-8 DECALS

**SECTION 11-8 DECALS**  
**CM2033/CM2046/CM2546/CM2558**



FIGURE & ITEM NO	PART NUMBER	DESCRIPTION	QTY.	REV.
11-8-1		<b>DECALS INSTALLATION</b>	Ref.	
	1281456	<b>DECALS INSTALLATION - (PRIOR TO AUGUST 1991) (COMMON PARTS - STANDARD)</b>	Ref.	D
	1281604	<b>DECALS INSTALLATION - (AUGUST 1991 TO PRESENT) (COMMON PARTS - STANDARD)</b>	Ref.	N
-1	Not Used			
-2	Not Used			
-3	3251813**	Decal - USA	1	
-4	1700195	Decal - Hydraulic Fluid (Prior to August 1991)	1	
	1701504**	Decal - Hydraulic Fluid (August 1991 to Present)	1	
-5	Not Used			
-6	4420039	Tape, Safety Tread	2 ft./61m	
-7	1701404	Decal - Fork Lift Area (Prior to August 1991)	2	
	1701508**	Decal - Fork Lift Area (August 1991 to Present)	2	
-8	Not Used			
-9	2820024	Tubing, Vinyl	2 ft./61m	
-10	3340612	Pad, Bumper (Prior to May 1995)	2 ft./61m	
	3340564	Pad, Bumper (May 1995 to Present)	2 ft./61m	
-11	0860520	Box, Manual Storage	1	
-12	1060279	Cable, Lanyard	1	
-13	1700157	Decal - Manual (Prior to August 1991)	1	
	1701509**	Decal - Manual (August 1991 to Present)	1	
-14	0641405	Bolt 1/4"-20NC x 5/8"	4	
-15	4751400	Flatwasher 1/4"	4	
-16	4761400	Lockwasher 1/4"	4	
-17	3311401	Nut 1/4"-20NC	4	
-18	Not Used			
-19	0840035	Boot, Handrail	4	
-20	1702631	Decal - Bar Code	1	
	1281456	<b>DECALS INSTALLATION - BROWN (PRIOR TO AUGUST 1991) (COMMON PARTS - VARIABLE)</b>	Ref.	D
	0251333	CM2033	Ref.	G
	0251334	CM2046	Ref.	F
	0251335	CM2546	Ref.	G
	0251336	CM2558	Ref.	G
	0251888	<b>DECALS INSTALLATION - BROWN (AUGUST 1991 TO PRESENT) (COMMON PARTS - VARIABLE)</b>	Ref.	—
-31	1701069*	Decal - Commander (Brown)	2	
-32	1701110*	Decal - JLG (Brown)	3	
-33	Not Used			
-34	Not Used			
-35	1701408*	Decal - Logo (Brown)	2	
-36	Not Used			
-37	Not Used			
-38	1701409*	Decal - JLG (Brown)	1	
-39	Not Required			
	2900809	Decal Kit - Brown (Includes Items With *)	1	

**SECTION 11 - 8 DECALS**

**SECTION 11-8 DECALS**  
**CM2033/CM2046/CM2546/CM2558**



FIGURE & ITEM NO	PART NUMBER	DESCRIPTION	QTY.	REV.
11—8—1		<b>DECALS INSTALLATION (CONTINUED)</b>	Ref.	
	0252313	<b>DECALS INSTALLATION - BLACK (COMMON PARTS - VARIABLE)</b>	Ref.	E
—31	1702011 <sup>+</sup>	Decal - Commander (Black) (April 1993 to Present)	2	
	1701613	Decal - Commander (Black) (Prior to April 1993)	2	
—32	1702009 <sup>+</sup>	Decal - JLG (Black) (April 1993 to Present)	3	
	1701435	Decal - JLG (Black) (Prior to April 1993)	3	
—33	Not Used			
—34	Not Used			
—35	Not Required			
—36	Not Used			
—37	Not Used			
—38	1702010 <sup>+</sup>	Decal - JLG (Black) (April 1993 to Present)	1	
	1701612	Decal - JLG (Black) (Prior to April 1993)	1	
—39	1702029 <sup>+</sup>	Decal - Sizzor (Black) (April 1993 to Present Only)	2	
	2900810	Decal Kit - Black (Includes Items With <sup>+</sup> )	1	
	1281604	<b>DECALS INSTALLATION (STANDARD PARTS)</b>	Ref.	N
—51	Consult Factory	Nameplate, Serial Number	1	
—52	3820014	Rivet 1/8" x 5/16"	4	
—53	1701510	Decal - Manual Descent	1	
—54	1700431	Decal - Brown/Orange Stripe (Machines With Brown Decals)	A/R	
	1701334	Decal - Brown/Orange Stripe (Machines With Black Decals Built Prior to April 1993)	A/R	
—55	1701310	Decal - Orange Stripe (Machines With Brown Decal Only)	A/R	
		<b>DECALS INSTALLATION - CM2033 MODEL DESIGNATION</b>	Ref.	
—100	1701403	Decal - CM2033 (Brown)	2	
	1701607	Decal - CM2033 (Black) (Prior to April 1993)	2	
	1702018	Decal - CM2033 (Black) (April 1993 to Present)	2	
		<b>DECALS INSTALLATION - CM2046 MODEL DESIGNATION</b>	Ref.	
—100	1701405	Decal - CM2046 (Brown)	2	
	1701608	Decal - CM2046 (Black) (Prior to April 1993)	2	
	1702019	Decal - CM2046 (Black) (April 1993 to Present)	2	
		<b>DECALS INSTALLATION - CM2546 MODEL DESIGNATION</b>	Ref.	
—100	1701406	Decal - CM2546 (Brown)	2	
	1701609	Decal - CM2546 (Black) (Prior to April 1993)	2	
	1702020	Decal - CM2546 (Black) (April 1993 to Present)	2	

**SECTION 11 - 8 DECALS**



# SECTION 11-8 DECALS

## CM2033/CM2046/CM2546/CM2558



FIGURE & ITEM NO	PART NUMBER	DESCRIPTION	QTY.	REV.
11—8—1		<b>DECALS INSTALLATION (CONTINUED)</b>	Ref.	
		<b>DECAL INSTALLATION - CM2558 - MODEL DESIGNATION</b>	Ref.	
—100	1701407	Decal - CM2558 (Brown)	2	
	1701610	Decal - CM2558 (Black) (Prior to April 1993)	2	
	1702021	Decal - CM2558 (Black) (April 1993 to Present)	2	
		<b>DECALS INSTALLATION - WORK LOAD</b>	Ref.	
—101		Work Load Decal Options: (Prior to August 1991 Only)		
	3252078	CM2033/CM2546	2	
	3252077	CM2046/CM2558	2	
		<b>DECALS INSTALLATION - GRADE/TIPPING</b>	Ref.	
—102		Grade/Tipping Decal Options:		
	3252153	CM2033 (Euro English, German, Dutch and Spanish Spec)	1	
	3252115	CM2033 (French and Italian Spec)	1	
	3252156	CM2046/CM2558 (All Specs)	1	
	3252115	CM2546 (All Specs)	1	
	0251889	<b>DECALS INSTALLATION - EURO ENGLISH SPEC (CM2033)</b>	Ref.	C
	0251893	<b>DECALS INSTALLATION - EURO ENGLISH SPEC (CM2046)</b>	Ref.	C
	0251897	<b>DECALS INSTALLATION - EURO ENGLISH SPEC (CM2546)</b>	Ref.	C
	0251901	<b>DECALS INSTALLATION - EURO ENGLISH SPEC (CM2558)</b>	Ref.	C
—151	1701071	Decal - Brake Release	1	
—152	1701122	Decal - Ground Control	1	
—153	1700713	Decal - Safety Prop	1	
—154	1701631	Decal - Caution	1	
	0251890	<b>DECALS INSTALLATION - FRENCH SPEC (CM2033)</b>	Ref.	C
	0251894	<b>DECALS INSTALLATION - FRENCH SPEC (CM2046)</b>	Ref.	C
	0251898	<b>DECALS INSTALLATION - FRENCH SPEC (CM2546)</b>	Ref.	C
	0251902	<b>DECALS INSTALLATION - FRENCH SPEC (CM2558)</b>	Ref.	C
—151	1701530	Decal - Liberation Des Friens Uniquement)	1	
—152	1701515	Decal - Commandes Sol	1	
—153	1701512	Decal - Support De Sécurité	1	
—154	1701629	Decal - Attention	1	
	0251891	<b>DECALS INSTALLATION - GERMAN SPEC (CM2033)</b>	Ref.	C
	0251895	<b>DECALS INSTALLATION - GERMAN SPEC (CM2046)</b>	Ref.	C
	0251899	<b>DECALS INSTALLATION - GERMAN SPEC (CM2546)</b>	Ref.	C
	0251903	<b>DECALS INSTALLATION - GERMAN SPEC (CM2558)</b>	Ref.	C
—151	1701521	Decal - Nur Zum Loesen Der Bremse Nicht Zum Schleppen Gebrauchien	1	
—152	1701525	Decal - Boden/Notfall Kontrolle	1	
—153	1701519	Decal - Sicherheitsstuetze	1	
—154	1701630	Decal - Actung	1	

SECTION 11 - 8 DECALS

**SECTION 11-8 DECALS**  
**CM2033/CM2046/CM2546/CM2558**



**SECTION 11-8 DECALS**

FIGURE & ITEM NO	PART NUMBER	DESCRIPTION	QTY.	REV.
11-8-1		<b>DECALS INSTALLATION (CONTINUED)</b>	Ref.	
	0252435	<b>DECALS INSTALLATION - DUTCH SPEC (CM2033)</b>	Ref.	B
	0252436	<b>DECALS INSTALLATION - DUTCH SPEC (CM2046)</b>	Ref.	B
	0252437	<b>DECALS INSTALLATION - DUTCH SPEC (CM2546)</b>	Ref.	B
	0252438	<b>DECALS INSTALLATION - DUTCH SPEC (CM2558)</b>	Ref.	B
-151	1701614	Decal - Alleen Voor Ontkoppelen Remmen. Niet om te Slepen	1	
-152	1701616	Decal - Grondbediening	1	
-153	1701615	Decal - Veiligheidsbalk	1	
-154	1701648	Decal - Dagelijkse Controle Lijst	1	
	0251892	<b>DECALS INSTALLATION - ITALIAN SPEC (CM2033)</b>	Ref.	C
	0251896	<b>DECALS INSTALLATION - ITALIAN SPEC (CM2046)</b>	Ref.	C
	0251900	<b>DECALS INSTALLATION - ITALIAN SPEC (CM2546)</b>	Ref.	C
	0251904	<b>DECALS INSTALLATION - ITALIAN SPEC (CM2558)</b>	Ref.	C
-151	1701536	Decal - Sblocco Frenco, Non Usane per il Traino	1	
-152	1701535	Decal - Comando De Terra	1	
-153	1701524	Decal - Appoggio Di Sicurezza	1	
-154	1701632	Decal - Attenzione	1	
	0253579	<b>DECALS INSTALLATION - SPANISH SPEC (CM2033)</b>	Ref.	A
	0253580	<b>DECALS INSTALLATION - SPANISH SPEC (CM2046)</b>	Ref.	A
	0253581	<b>DECALS INSTALLATION - SPANISH SPEC (CM2546)</b>	Ref.	A
	0253582	<b>DECALS INSTALLATION - SPANISH SPEC (CM2558)</b>	Ref.	A
-151	Not Required			
-152	1701858	Decal - Controles Tierra/Emerg	1	
-153	1701856	Decal - Puntal de Seguridad	1	
-154	1701861	Decal - Precaucion	1	
	0251642	<b>WARNING STRIPES INSTALLATION (EXTENDABLE PLATFORMS ONLY) (NOT SHOWN)</b>	Ref.	—
	420052	Tape - Black/Yellow	4 ft./1.2m	
	0252452	<b>DECAL INSTALLATION - OUTDOOR USE</b>	Ref.	—
-201	3252154	Nameplate - Capacity	1	
	0255981	<b>CE DECAL INSTALLATION (NOT SHOWN)</b>	Ref.	—
	3252482	Decal - CE	2	

# SECTION 12 RECOMMENDED SERVICE PARTS STOCK

CM1432/CM1432 PLUS/CM1732

The following lists will service fleets of machines (built to current production per date on the front cover) with emergency repair parts which can be installed in the field. Parts from the list should be replaced when inventory is depleted to keep service parts stock supplied. For further information, contact your JLG dealer or the JLG Industries Parts Department.

SECTION 12 RECOMMENDED SERVICE PARTS STOCK

JLG PART NO.	DESCRIPTION	QTY. PER FLEET SIZE		
		1-4	5-9	10 or More
<b>STANDARD PARTS</b>				
4360277	Limit Switch (Figure 13-1-4 and 13-4-2)	1	1	1
4360349	Sensor, Level (Figure 13-1-4)	1	1	1
7011657	Fuse - 5 Amp (Figure 13-1-5)	1	1	1
7011509	Breaker, Circuit (Figure 13-1-5)	1	1	1
7011576	Diode - 70 Amp (Figure 13-1-5)	2	2	2
7011551	Control (Figure 13-1-5)	1	1	1
3740068	Relay (Figure 13-2-1)	1	1	1
7010944	Flex Coupling Kit (Figure 13-2-2)	1	1	1
2400041	Fuse - 200 Amp (Figure 13-2-1)	2	2	2
4360202	Switch, Toggle (Figure 13-2-1)	1	1	1
4360319	Switch, Key (Figure 13-2-1)	1	1	1
7012560	Key, Replacement (Figure 13-2-1)	1	1	1
4360070	Breaker, Circuit (Figure 13-2-1)	1	1	1
4360155	Switch, Master (Figure 12-2-1)	1	1	1
3740069	Relay (Figure 13-2-1 and 13-7-1)	1	1	1
2120072	Element, Filter (Figure 13-2-2)	4	8	12
1340052	Breather, Air (Figure 13-2-2)	1	1	1
7012726	Coil - Rexroth (Figure 13-2-3)	1	1	1
7012732	Coil - Rexroth (Figure 13-2-3)	1	1	1
7012727	Rexroth (Figure 13-2-3)	1	1	1
7012900	Coil - 20 Volt (Figure 13-2-3)	1	1	1
7012934	Sequence Valve Cartridge (Figure 13-2-3)	1	1	1
4360339	Switch, Push Button (Figure 13-4-4)	1	1	1
4360267	Block, Switch Contact (Figure 13-4-4)	1	1	1
4360289	Switch, Push/Pull (Figure 13-4-4)	1	1	1
4360318	Switch, Toggle (Figure 13-4-4)	1	1	1
7012658	Fuse - 7.5 Amp (Figure 13-4-4)	2	2	2
4360274	Switch, Push Button (Figure 13-4-4)	1	1	1
4360112	Breaker, Circuit (Figure 13-4-4)	1	1	1
0610105	Card, Relay (Figure 13-4-4)	1	1	1
3990010	Diode - 6 Amp (Figure 13-7-1)	2	2	2
<b>VARIABLE PARTS</b>				
7011548	Fuse - 10 Amp (Figure 13-1-5)	2	2	2
7011657	Fuse - 5 Amp (Figure 13-1-5)	2	2	2
4360236	Switch, Actuator (Platform Extension with Standard Handrails) (Figure 13-4-2)	1	1	1
4360328	Switch, Toggle (Toggle Switch Drive) (Figure 13-4-4)	1	1	1
4360314	Switch, Toggle (Toggle Switch Drive) (Figure 13-4-4)	1	1	1
4360355	Switch, Toggle (Toggle Switch Drive) (Figure 13-4-4)	1	1	1
1600156	PQ Controller (PQ Bang-Bang Drive) (Figure 13-4-4)	1	1	1
7003789	Switch, Steer (PQ Controller Drive)	1	1	1
7011937	Electrical Assembly (PQ Bang-Bang Drive)	1	1	1
1600160	PQ Controller (PQ Proportional Drive) (Figure 13-4-4)	1	1	1
7011939	Electrical Assembly (PQ Proportional Drive)	1	1	1
7011923	Electrical Assembly (PQ Proportional Drive)	1	1	1
7003751	Potentiometer (PQ Proportional Drive)	1	1	1
2900838	U.S. Standard Fastener (Hardware Kit)	1	1	1
7014676	U.S. Standards Tool Kit	1	1	1



# SECTION 13 ILLUSTRATED PARTS LIST CM1432/CM1432 PLUS/CM1732

FIGURE NO.	DESCRIPTION	PAGE NO.
<b>SECTION 13-1 — FRAME</b>		
13-1-1	Frame, Steering and Drive Installation .....	13-1-2
13-1-2	Drive Motor Assemblies .....	13-1-4
13-1-3	Rear Axle and Brake Installations .....	13-1-6
13-1-4	Frame Mounted Components Installation .....	13-1-8
13-1-5	Battery Charger Assembly (Single Voltage) .....	13-1-12
13-1-6	Battery Charger Assembly (Dual Voltage) .....	13-1-16
<b>SECTION 13-2 — GROUND COMPONENTS</b>		
13-2-1	Electrical Components Installation .....	13-2-2
13-2-2	Hydraulic Components and Covers Installation .....	13-2-6
13-2-3	Control Valve Assembly - Hydro-Air .....	13-2-10
<b>SECTION 13-3 — SIZZOR ARMS</b>		
13-3-1	Sizzor Arms Installation - CM1432 and CM1432 Plus .....	13-3-2
13-3-2	Sizzor Arms Installation - CM1732 .....	13-3-6
13-3-3	Arm Guards Instalation (Prior to July 1992) .....	13-3-8
13-3-4	Arm Guards Installation (July 1992 to June 1995) .....	13-3-10
13-3-5	Arm Guards Installation (June 1995 to Present) .....	13-3-12
<b>SECTION 13-4 — PLATFORM</b>		
13-4-1	Platform and Handrail Installation .....	13-4-2
13-4-2	Optional Platform Extension Installation with Standard Handrails .....	13-4-6
13-4-2A	Optional Platform Extension Installaiton with Fold-Down Handrails .....	13-4-8
13-4-3	Steel Platform Console Box Assembly .....	13-4-10
13-4-4	Molded Platform Console Box Assembly .....	13-4-14
<b>SECTION 13-5 — CYLINDERS</b>		
13-5-1	Brake Cylinder Assembly .....	13-5-2
13-5-2	Lift Cylinder Sub-Assembly .....	13-5-4
13-5-3	Steer Cylinder Assembly .....	13-5-8
<b>SECTION 13-6 — HYDRAULICS</b>		
13-6-1	Hydraulic Diagram - Standard .....	13-6-2
<b>SECTION 13-7 — ELECTRICAL</b>		
13-7-1	Electrical Diagrams and Components Chart .....	13-7-2
13-7-2	Electrical Diagram - Toggle Switch Drive (Standard Euro Spec) .....	13-7-8
13-7-3	Electrical Diagram - Toggle Switch Drive (Australian Spec) .....	13-7-9
13-7-4	Electrical Diagram -Toggle Switch Drive (French Spec) .....	13-7-10
13-7-5	Electrical Diagram - PQ Controller Bang-Bang Drive (Standard Euro Spec) .	13-7-11
13-7-6	Electrical Diagram - PQ Controller Bang-Bang Drive (Australia Spec) .....	13-7-12
13-7-7	Electrical Diagram - PQ Controller Bang-Bang Drive (French Spec) .....	13-7-13
13-7-8	Electrical Diagram - Circuit Cards .....	13-7-15
13-7-9	Main Electrical Connector and Tools .....	13-7-16
<b>SECTION 13-8 —DECALS</b>		
13-8-1	Decals Installation - CM1432 & CM1432 Plus .....	13-8-2
13-8-2	Decals Installation - CM1732 .....	13-8-6



**SECTION 13-1 FRAME**  
**CM1432/CM1432 PLUS/CM1732**



**TABLE OF CONTENTS**

FIGURE NO.	DESCRIPTION	PAGE NO.
13-1-1	Frame, Steering and Drive Installations .....	13-1-2
13-1-2	Drive Motor Assemblies .....	13-1-4
13-1-3	Rear Axle and Brake Installations .....	13-1-6
13-1-4	Frame Mounted Components Installation .....	13-1-8
13-1-5	Battery Charger Assembly (Single Voltage) .....	13-1-12
13-1-6	Battery Charger Assembly (Dual Voltage) .....	13-1-16

**S E C T I O N**  
**13 - 1**  
**F R A M E**





# SECTION 13-1 FRAME CM1432/CM1432 PLUS/CM1732

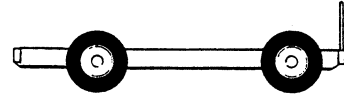

# SECTION 13 - 1 FRAME

FIGURE & ITEM NO	PART NUMBER	DESCRIPTION	QTY.	REV.
13-1-1		<b>FRAME, STEERING AND DRIVE INSTALLATION</b>	Ref.	
		<b>FRAME OPTIONS:</b>		
-1	2360338	Frame (Standard)	1	-
	2360360	Frame (Optional Lifting Lugs/Standard 1432 Plus)	1	
-2	0961626	Bushing, Superoilite	4	
		<b>STEERING AND DRIVE INSTALLATION (STANDARD PARTS)</b>	Ref.	
-3	1682996	Steer Cylinder Assembly (Prior to August 1995) (See Section 13-5 for Breakdown)	1	
	1683408	Steer Cylinder Assembly (August 1995 to Present) (See Section 13-5 for Breakdown)	1	
-4	0641616	Bolt 3/8"-16NC x 2"	4	
-5	4711600	Flatwasher 3/8" Narrow	4	
-6	4070769	Shim	2	
		Loctite #242	A/R	
-7	3322202	Nut, Jam 3/4"-16NF	2	
-8	0361928	Bar, Adjustment	2	
-9	Not Used			
-10	3430612	Pin, Clevis - 3/8" x 1 1/2"	1	
-11	3450404	Pin, Cotter - 1/8" x 1"	1	
-12	Not Used			
-13	3311605	Locknut 3/8"-16NC	1	
-14	4751600	Flatwasher 5/8"	1	
-15	4740419	Washer, Thrust	1	
-16	4300093	Stud	1	
	0100011	Loctite #242	1	
-17	3160173	Drive Motor Assembly (See Figure 13-2 for Breakdown)	2	
-18	0641816	Bolt 1/2"-13NC x 2"	4	
-19	4761800	Lockwasher 1/2"	4	
-20	3311801	Nut 1/2"-13NC	4	
	0100011	Loctite #242	A/R	
-21	2780165	Hub, Wheel	2	
-22	3450406	Pin, Cotter 1/8" x 1 1/2"	2	
-23	0630305	Bolt, Wheel	10	
-24	3311601	Nut 3/8"-16NC	4	
-25	1120417	Cap, Plastic	2	
	0251922	<b>STEERING AND DRIVE INSTALLATION - PRIOR TO AUGUST 1994 (VARIABLE PARTS)</b>	Ref.	G
-51	4130257	Spindle	2	
-52	1360235	Clevis, Steer (Use 1360260 Clevis and 0961931 Bushing as replacement)	2	
-53 to -55	Not Required			
	0255020	<b>STEERING AND DRIVE INSTALLATION - AUGUST 1994 TO PRESENT (VARIABLE PARTS)</b>	Ref.	A
-51	4130320	Spindle	2	
-52	1360260	Clevis, Steer	2	
-53	0961931	Bushing, Fiberglide	2	
-54	2160006	Fitting, Grease	2	
-55	3780166	O-Ring	2	
		<b>TIRE AND WHEEL ASSEMBLIES</b>	Ref.	
-100	4520140	Tire/Wheel Assembly (Solid) (Standard)	4	
	4520165	Tire/Wheel Assembly (Non-Marking) (Optional)	4	

# SECTION 13-1 FRAME CM1432/CM1432 PLUS/CM1732

FIGURE 13-1-2. DRIVE MOTOR ASSEMBLIES.

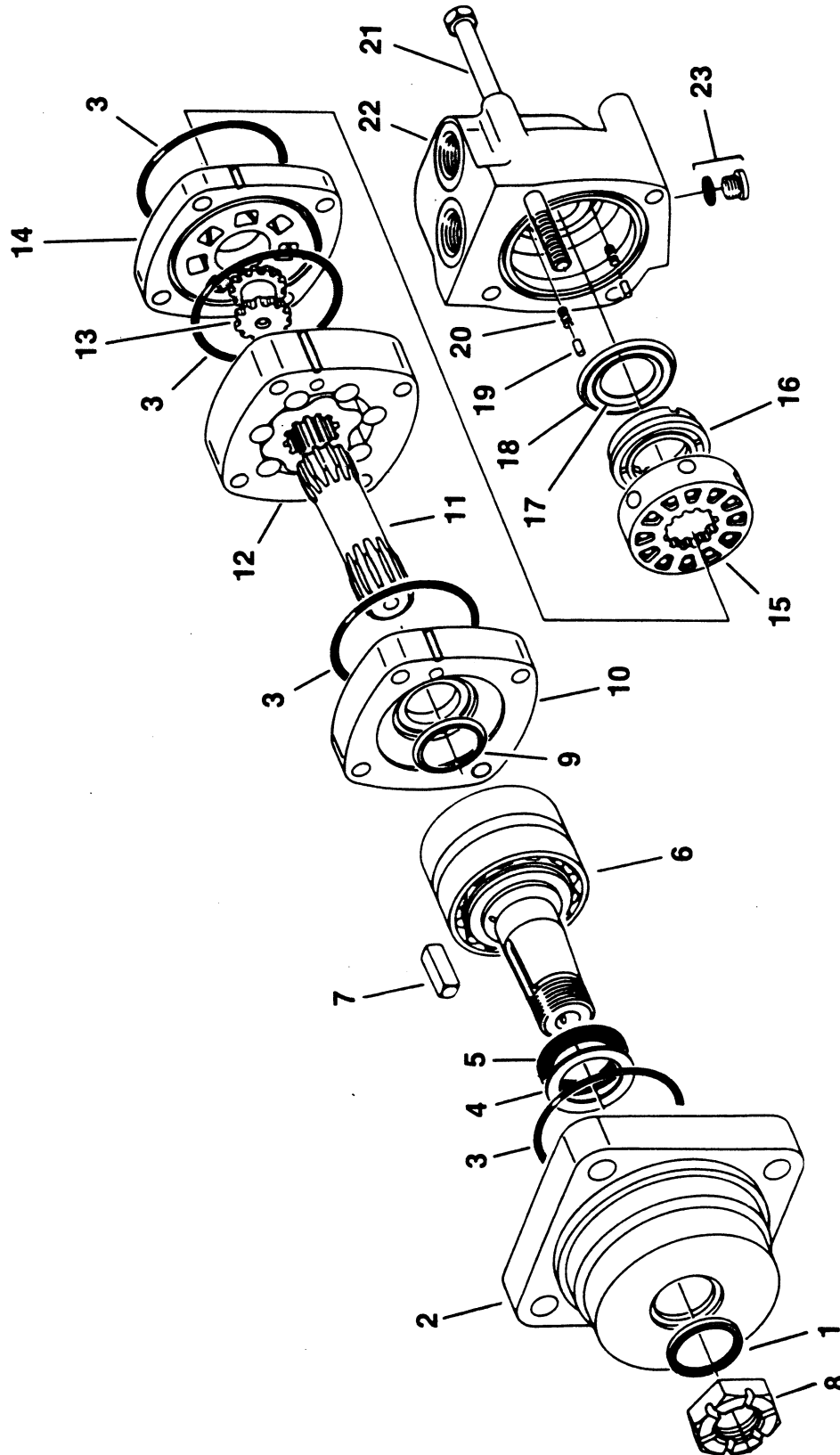
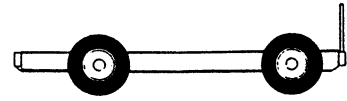

# SECTION 13-1 FRAME CM1432/CM1432 PLUS/CM1732

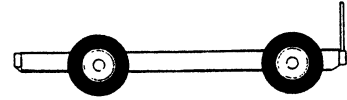

**SECTION 13-1 FRAME**

FIGURE & ITEM NO	PART NUMBER	DESCRIPTION	QTY.	REV.
13—1—2		<b>DRIVE MOTOR ASSEMBLIES</b>	Ref.	
	3160173	<b>DRIVE MOTOR ASSEMBLIES (STANDARD PARTS)</b>	Ref.	
—1	Kit	Seal, Dust	1	
—2	7009931	Housing, Bearing	1	
—3	Kit	Seal	4	
—4	Kit	Ring, Back-up	1	
—5	Kit	Seal, Shaft	1	
—6	7009932	Shaft and Bearing	1	
—7	7009933	Key	1	
—8	7009934	Nut, Castle	1	
—9	Kit	Seal, Shaft Face	1	
—10	7009982	Plate, Wear	1	
—11	7009979	Drive	1	
—12	7009980	Geroler	1	
—13	7009905	Drive, Valve	1	
—14	7009983	Plate, Valve	1	
—15	7009927	Valve	1	
—16	7009909	Ring, Balance	1	
—17	Kit	Seal, Face - Inner	1	
—18	Kit	Seal, Face - Outer	1	
—19	7009912	Pin	2	
—20	7009913	Spring	2	
—21	7009929	Bolt	4	
—22	7009930	Housing, Valve	1	
—23	7002157	Plug Assembly	1	
	2900699	----- Seal Kit (Includes Items 1,3,4,5,9,17 and 18)	1	

# SECTION 13-1 FRAME CM1432/CM1432 PLUS/CM1732

FIGURE 13-1-3. REAR AXLE AND BRAKE INSTALLATIONS.

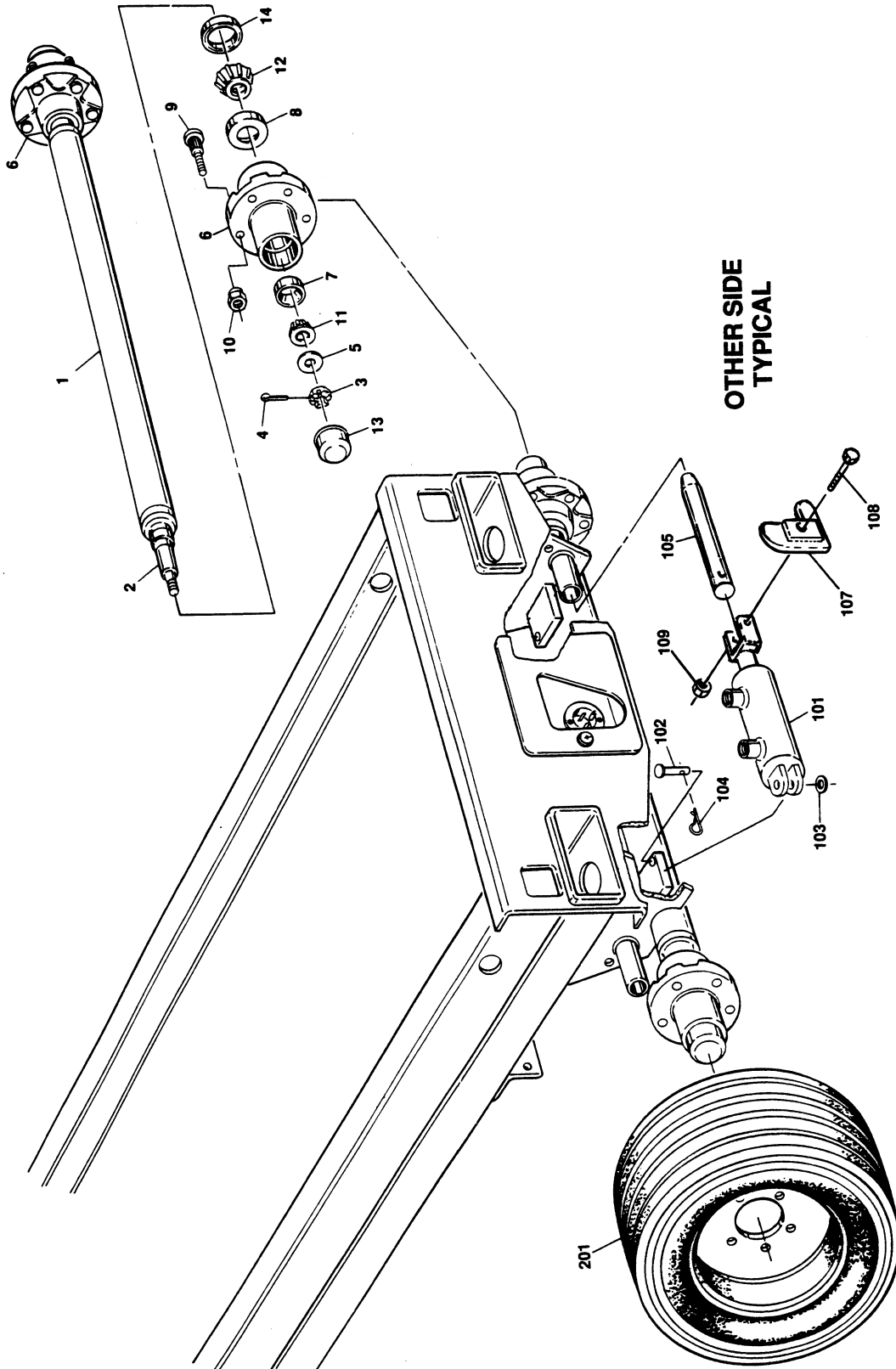
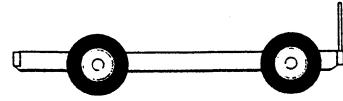

# SECTION 13-1 FRAME CM1432/CM1432 PLUS/CM1732



**SECTION 13-1 FRAME**

FIGURE & ITEM NO	PART NUMBER	DESCRIPTION	QTY.	REV.
13—1—3		<b>REAR AXLE AND BRAKE INSTALLATIONS</b>	Ref.	
	0280120	<b>AXLE ASSEMBLY</b>	Ref.	A
—1	Not Serviced	Tube, Axle	1	
—2	Not Serviced	Spindle	2	
—3	7010641	Nut, Spindle	2	
—4	7010642	Pin, Cotter	2	
—5	7010643	Washer	2	
—6	7010644	Hub Assembly	2	
—7	Kit	Cup, Bearing (Outer) (1 Per Hub)	2	
—8	Kit	Cup, Bearing (Inner) (1 Per Hub)	2	
—9	7012613	Stud, Wheel 1/2"-20NF	10	
—10	7010645	Lugnut 1/2"-20NF	10	
—11	Kit	Cone, Bearing (Outer)	2	
—12	Kit	Cone, Bearing (Inner)	2	
—13	7010648	Cap, Dust	2	
—14	Kit	Seal, Hub	2	
	2900778	----- Bearing Kit (Includes Qty. 1 of Items 7,8,11,12 and 14)	2	
	0252111	<b>BRAKE INSTALLATION</b>	Ref.	C
—101	1683098	Brake Cylinder Assembly (See Section 13-5 for Breakdown)	2	
—102	3430616	Pin, Clevis 3/8" x 2"	2	
—103	4711600	Flatwasher 3/8" Narrow	2	
—104	3450304	Pin, Cotter 3/32" x 1"	2	
—105	3841129	Rod, Brake	2	
—106	Not Used			
—107	4844188	Cam Weldment	2	
—108	0641624	Bolt 3/8"-16NC x 3"	2	
—109	3311605	Locknut 3/8"-16NC	2	
	0010439	<b>TIRE AND WHEEL ASSEMBLY OPTIONS</b>	Ref.	A
—201	4520140	Tire and Wheel Assembly (Solid) (Standard)	2	
	4520116	Tire and Wheel Assembly (Non-Marking) (Optional)	2	
	0255980	<b>BRAKE RELEASE VALVE INSTALLATION (AUSTRALIAN SPEC AFTER OCTOBER 1995) (NOT SHOWN)</b>	Ref.	—
	1702728	Decal Located on Left Side Frame at Rear Wheel)	1	
	4640128	Valve (Located in Hydraulic Brake Line)	1	

# SECTION 13-1 FRAME CM1432/CM1432 PLUS/CM1732

FIGURE 13-1-4. FRAME MOUNTED COMPONENTS  
INSTALLATION.

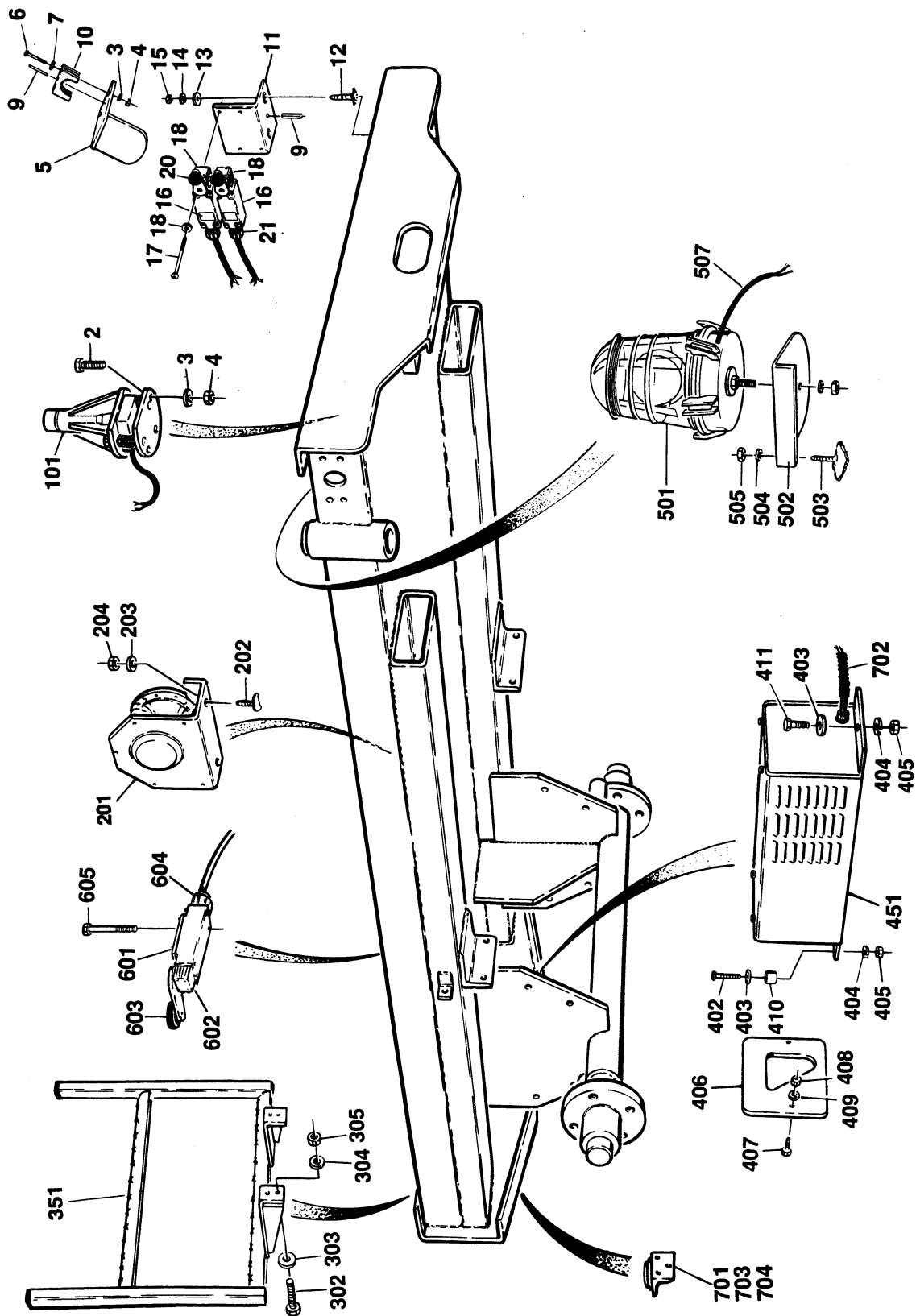
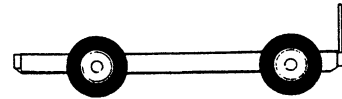

# SECTION 13-1 FRAME CM1432/CM1432 PLUS/CM1732

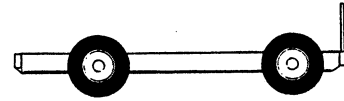

**SECTION 13 - 1 FRAME**

FIGURE & ITEM NO	PART NUMBER	DESCRIPTION	QTY.	REV.
13-1-4		<b>FRAME MOUNTED COMPONENTS INSTALLATION</b>	Ref.	
		<b>SWITCH INSTALLATION (STANDARD PARTS)</b>	Ref.	
-1	Not Used			
-2	0641407	Bolt 1/4"-20NC x 7/8"	2	
-3	4761400	Lockwasher 1/4"	4	
-4	3311401	Nut 1/4"-20NC	4	
-5	4844440	Cam Weldment	1	
-6	0641420	Bolt 1/4"-20NC x 2 1/2"	2	
-7	4751400	Flatwasher 1/4"	2	
-8	Not Used			
-9	3440616	Rollpin 3/16" x 1"	2	
-10	1320021	U-Clamp	1	
-11	0901827	Plate, Mounting	1	
-12	4300038	Stud (Welded on Part)	2	
-13	4751500	Flatwasher 5/16"	2	
-14	4761500	Lockwasher 5/16"	2	
-15	3311501	Nut 5/16"-18NC	2	
-16	4360277	Switch, Limit	A/R	
		All Euro Spec Except Italian Spec	2	
		Italian Spec	1	
-17	0721014	Screw, Machine #10-24NC x 1 3/4"	A/R	
-18	4360236	Head, Switch	A/R	
-19	4761000	Lockwasher #10	4	
-20	4360278	Roller and Arm	A/R	
-21	4460049	Connector, Strain Relief	A/R	
	0252379	<b>SWITCHES INSTALLATION (MACHINES WITH STEEL CONSOLE BOX) (VARIABLE PARTS)</b>	Ref.	B
-101	4360296	Sensor, Level	1	
	0253493/0253494	<b>SWITCHES INSTALLATION (MACHINES WITH MOLDED CONTROL BOX) (VARIABLE PARTS)</b>	Ref.	B
-101	4360349	Sensor, Level	1	
	7012608	Fuse 1.5 Amp (Black Sensor Only) (Orange and Blue Sensor are Self-Resetting - No Fuse Required)	1	
	0251762	<b>DESCENT ALARM INSTALLATION - OPTIONAL</b>	Ref.	B
	0251761	<b>MOTION ALARM INSTALLATION - OPTIONAL</b>	Ref.	B
	0251762	<b>TRAVEL ALARM INSTALLATION - OPTIONAL</b>	Ref.	B
-201		Alarm Options:	1	
	0140025	Alarm, Horn (No Longer Available - Use 0140033)		
	0140033	Alarm, Horn (August 1993 to Present)		
-202	4300038	Stud (Welded on Part)	2	
-203	4761500	Lockwasher 5/16"	2	
-204	3311501	Nut 5/16"-18NC	2	

SECTION 13-1 FRAME

**SECTION 13-1 FRAME  
CM1432/CM1432 PLUS/CM1732**

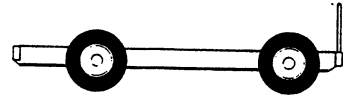
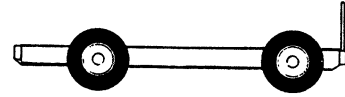

FIGURE & ITEM NO	PART NUMBER	DESCRIPTION	QTY.	REV.
13-1-4		<b>FRAME MOUNTED COMPONENTS INSTALLATION (CONTINUED)</b>	Ref.	
		<b>LADDER INSTALLATION (STANDARD PARTS)</b>	Ref.	
—301	Not Used			
—302	0641610	Bolt 3/8"-16NC x 1 1/4"	4	
—303	4761600	Lockwasher 3/8"	4	
—304	4751600	Flatwasher 3/8"	4	
—305	3311601	Nut 3/8"-16NC	4	
	0252853	<b>LADDER INSTALLATION (PRIOR TO APRIL 1995) (VARIABLE PARTS)</b>	Ref.	A
—351	4844049	Ladder Weldment	1	
	3520071	Cap, Plug	2	
	0255705	<b>LADDER INSTALLATION (APRIL 1995 TO PRESENT) (VARIABLE PARTS)</b>	Ref.	—
—351	4844844801	Ladder Weldment	1	
	3520071	Cap, Plug	2	
	1281666	<b>BATTERY CHARGER INSTALLATION (STANDARD PARTS)</b>	Ref.	I
—401	Not Used			
—402	0641512	Bolt 5/16"-18NC x 1 1/2"	1	
—403	4751500	Flatwasher 5/16"	2	
—404	4761500	Lockwasher 5/16"	2	
—405	3311501	Nut 5/16"-18NC	2	
—406	3535688	Plate, Cover	1	
—407	0641406	Bolt 1/4"-20NC x 3/4"	2	
	4751400	Flatwasher 1/4" (Not Shown)	2	
—408	3311401	Nut 1/4"-20NC	2	
—409	4761400	Lockwasher 1/4"	2	
—410	0960807	Bushing, Spacer	1	
—411	0641508	Bolt 5/16"-18NC x 1"	1	
	0252183	<b>BATTERY CHARGER INSTALLATION - 220 SINGLE VOLTAGE (ALL EURO EXCEPT UK AND AUSTRALIAN SPEC) (VARIABLE PARTS)</b>	Ref.	F
—451	0400094	Battery Charger Assembly - 220 Single Voltage (See Figure 13-1-5 for Breakdown)	1	
	0252989	<b>BATTERY CHARGER INSTALLATION - 250 SINGLE VOLTAGE (UK SPEC - ALL AND AUSTRALIAN SPEC - PRIOR TO OCTOBER 1994) (VARIABLE PARTS)</b>	Ref.	C
—451	0400100	Battery Charger Assembly - 250 Single Voltage (See Figure 13-1-5 for Breakdown)	1	



# SECTION 13-1 FRAME CM1432/CM1432 PLUS/CM1732



# SECTION 13-1 FRAME

FIGURE & ITEM NO	PART NUMBER	DESCRIPTION	QTY.	REV.
13-1-4		<b>FRAME MOUNTED COMPONENTS INSTALLATION (CONTINUED)</b>	Ref.	
	0255101	<b>BATTERY CHARGER INSTALLATION - 250 SINGLE VOLTAGE (AUSTRALIAN SPEC - OCTOBER 1994 TO PRESENT (VARIABLE PARTS))</b>	Ref.	B
-451	0400132	Battery Charger Assembly - 250 Single Voltage (See Figure 13-1-5 for Breakdown)	1	
	0254044	<b>BATTERY CHARGER INSTALLATION - DUAL VOLTAGE (UK ONLY) (VARIABLE PARTS)</b>	Ref.	B
-451	0400110	Battery Charger Assembly (See Figure 13-1-6 for Breakdown)	1	
	0252274	<b>BEACON LIGHT INSTALLATION (OPTIONAL)</b>	Ref.	C
-501	2920087	Light, Beacon	1	
-502	0901546	Bracket, Mounted	1	
-503	4300032	Stud (Welded on Part)	2	
-504	4761400	Lockwasher 1/4"	2	
-505	3311401	Nut 1/4"-20NC		
-506	Not Used			
-507	1060341	Cable, Electrical - 16/2	6 ft./1.8m	
	0252529	<b>LIMIT SWITCH INSTALLATION (FRENCH SPEC ONLY - OVERLOAD BY-PASS)</b>	Ref.	B
-601	4360277	Switch, Limit	1	
-602	4360236	Head, Switch Actuator	1	
-603	4360237	Roller and Arm	1	
-604	4460052	Connector, Strain Relief	1	
-605	3900168	Screw, Special	2	
	0254480	<b>TUV COMPONENTS INSTALLATION</b>	Ref.	A
-701	3820021	Rivet	3	
-702	2820035	Loom	4 ft./1.3m	
-703	2420140	Level, Circular	1	
-704	4844685	Mount, Level	1	

# SECTION 13-1 FRAME CM1432/CM1432 PLUS/CM1732

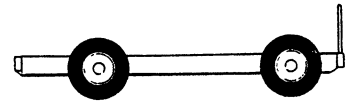
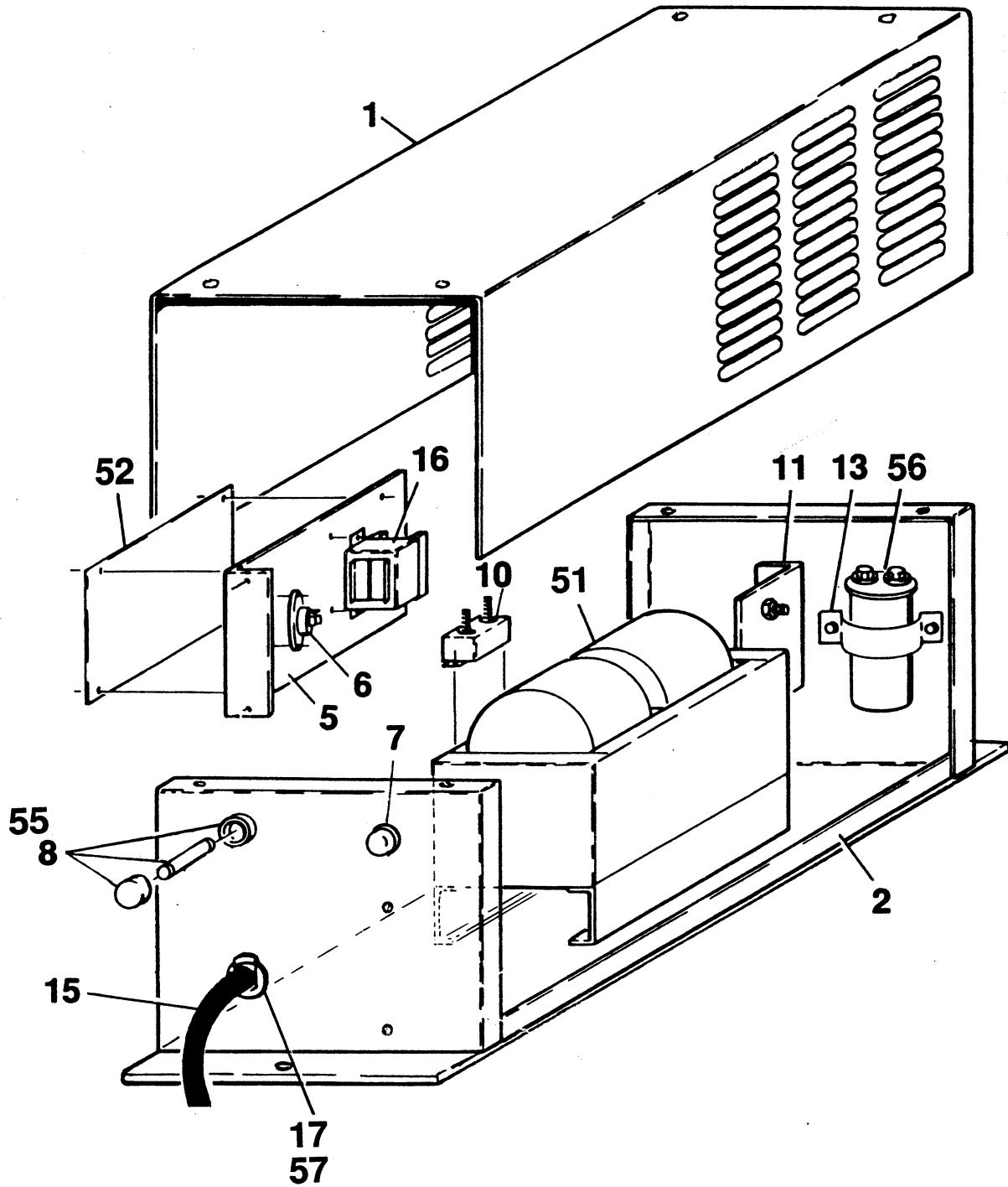
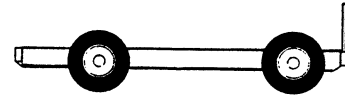

FIGURE 13-1-5. BATTERY CHARGER ASSEMBLY.



# SECTION 13-1 FRAME CM1432/CM1432 PLUS/CM1732



SECTION 13-1 FRAME

FIGURE & ITEM NO	PART NUMBER	DESCRIPTION	QTY.	REV.
13—1—5		<b>BATTERY CHARGER ASSEMBLY- SINGLE VOLTAGE (STANDARD PARTS)</b>	Ref.	
		<b>Note: Battery Charger Serial Number Nameplate located on side of Charger. First line is the Charger spec and Date Code. Example: BA515 (Spec) AP (Date Code). First Letter in the Date Code Indicates Month (A-January/B - February/C-March/ etc. with exception of letter "I" which is not used). Second Letter indicated year (N - 1992/O - 1993/ P - 1994/S1995/etc.)</b>		
—1	Not Serviced	Cover, Case	1	
—2	Not Serviced	Case, Main	1	
—3	Not Used			
—4	Not Used			
—5	7011535	Bracket, Mounting - Circuit Board	1	
—6	7011517	Triac	1	
—7	7011506	Light, Pilot (When Equipped)	1	
—8	7011507	Holder, Fuse	A/R	
—9	Not Used			
—10	7011509	Breaker, Circuit	1	
—11	7011616	Heatsink Assembly	1	
	7011576	Diode - 70 Amp	2	
	7011596	Varistor	1	
	7011615	Heatsink	1	
—12	Not Used			
—13	7011560	Strap, Mounting - Condenser	1	
—14	Not Used			
—15	7011544	Cord, AC (Purchased Receptacle Locally)	1	
—16	7011551	Control	1	
—17	7011528	Relief, Strain	A/R	
	0400094	<b>BATTERY CHARGER ASSEMBLY - 220 SINGLE VOLTAGE (EURO EXCEPT UK AND AUSTRALIAN SPEC (VARIABLE PARTS)</b>	Ref.	B
—51	7011533	Transformer	1	
—52	7011659	Board, Circuit	1	
—53	Not Used			
—54	Not Used			
—55	7011548	Fuse - 10 Amp	1	
—56	7011523	Condensor - 4mfd	1	
—57	Not Required			
—58	Not Required			



**SECTION 13-1 FRAME  
CM1432/CM1432 PLUS/CM1732**

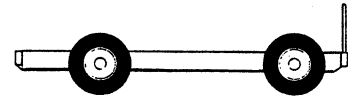

**SECTION 13-1 FRAME**

FIGURE & ITEM NO	PART NUMBER	DESCRIPTION	QTY.	REV.
13-1-5		<b>BATTERY CHARGER ASSEMBLY - SINGLE VOLTAGE (STANDARD PARTS)(CONTINUED)</b>	Ref.	
	0400100	<b>BATTERY CHARGER ASSEMBLY - 250 SINGLE VOLTAGE (UK SPEC - ALL AND AUSTRALIAN SPEC - PRIOR TO OCTOBER 1994) (VARIABLE PARTS)</b>	Ref.	—
—51	7011658	Transformer	1	
—52	7011617	Board, Circuit	1	
—53	Not Used			
—54	Not Used			
—55	7011657	Fuse - 5 Amp Slo-Blo	1	
—56	7011543	Condensor - 6mfd	1	
—57	Not Required			
—58	Not Required			
	0400132	<b>BATTERY CHARGER ASSEMBLY - 250 SINGLE VOLTAGE (AUSTRALIAN SPEC - OCTOBER 1994 TO PRESENT)</b>	Ref.	—
—51	7011658	Transformer	1	
—52	7011659	Board, Circuit	1	
—53	Not Used			
—54	Not Used			
—55	7011657	Fuse - 5 Amp Slo-Blo	1	
—56	7011543	Condensor - 6mfd	1	
—57	7011667	Socket, AC	1	
—58	7011684	Relay (September 1995 to Present) (No tShown)	1	



# SECTION 13-1 FRAME CM1432/CM1432 PLUS/CM1732

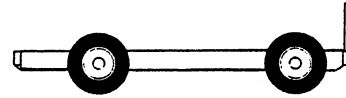

**SECTION 13-1 FRAME**

FIGURE & ITEM NO	PART NUMBER	DESCRIPTION	QTY.	REV.
13—1—6	0400110	<b>BATTERY CHARGER ASSEMBLY - DUAL VOLTAGE (UK SPEC ONLY)</b>  <b>Note: Dual Voltage Battery Chargers with date code prior to January 1995 should be replaced as a unit. Consult JLG Industries (Europe) for replacement. Battery Charger Serial Number Nameplate located on side of Charger. First line is the Charger spec and Date Code. Example: BA515 (Spec) AP (Date Code). First Letter in the Date Code indicates Month (A-January/B - February/C-March/etc. with exception of letter "I" which is not used). Second Letter indicated year (N - 1992/O - 1993/P - 1994/S1995/etc.)</b>	Ref.	—
—1	Not Serviced	Cover, Case (Not Shown)	1	
—2	Not Serviced	Case, Main	1	
—3	7011681	Transformer	1	
—4	7011678	Board, Circuit	1	
—5	7011516	Bracket, Mounting - Circuit Board	1	
—6	Not Used			
—7	7011506	Light, Pilot (When Equipped)	1	
—8	7011507	Holder, Fuse	2	
—9	7011657	Fuse - 5 Amp	2	
—10	7011509	Breaker, Circuit	1	
—11		Heatsink Assembly	1	
	7011576	Diode - 20 Amp	2	
	7011596	Varistor	1	
—12	7011560	Strap, Condensor	1	
—13	7011423	Condenser - 4mfd	1	
—14	7011544	Cord, AC (Purchase Receptacle Locally)	8 11/25,	
—15	Not Used			
—16	7011528	Connector, Strain Relief	1	
—17	7011517	Triac	1	
—18	7011551	Control, Circuit	1	
—19	7011685	Switch, Toggle - 4PDT	1	





# SECTION 13-2 GROUND COMPONENTS CM1432/CM1432 PLUS/CM1732

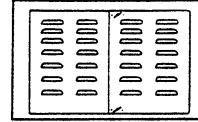

## TABLE OF CONTENTS

FIGURE NO.	TITLE	PAGE NO.
13-2-1	Electrical Components Installation .....	13-2-2
13-2-2	Hydraulic Components and Covers Installation .....	13-2-6
13-2-3	Control Valve Assembly - Hydro-Air .....	13-2-10

**SECTION 13 - 2 GROUND COMPONENTS**

# SECTION 13-2 GROUND COMPONENTS CM1432/CM1432 PLUS/CM1732

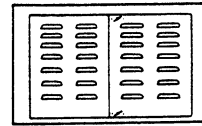
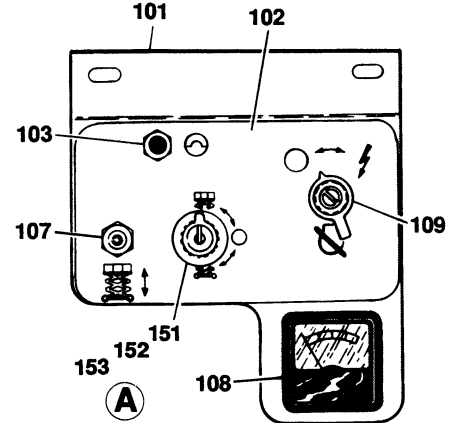
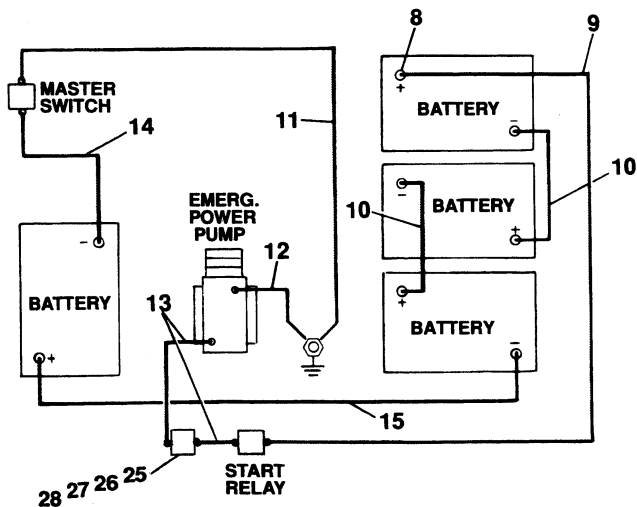
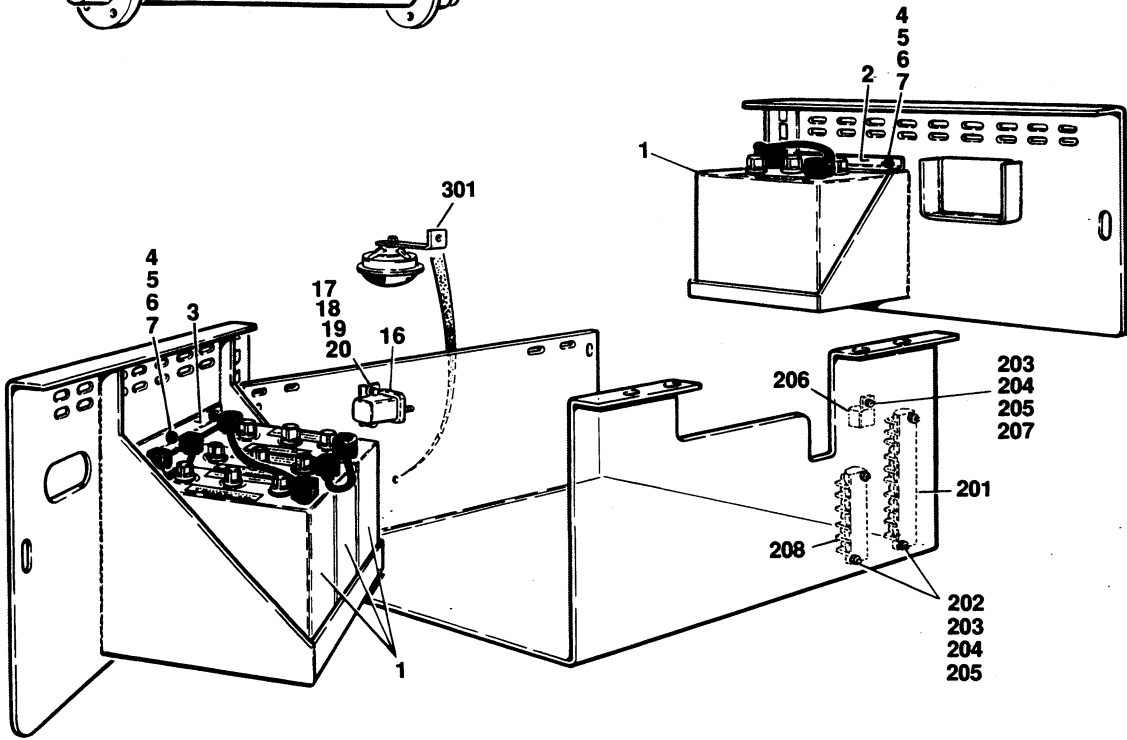
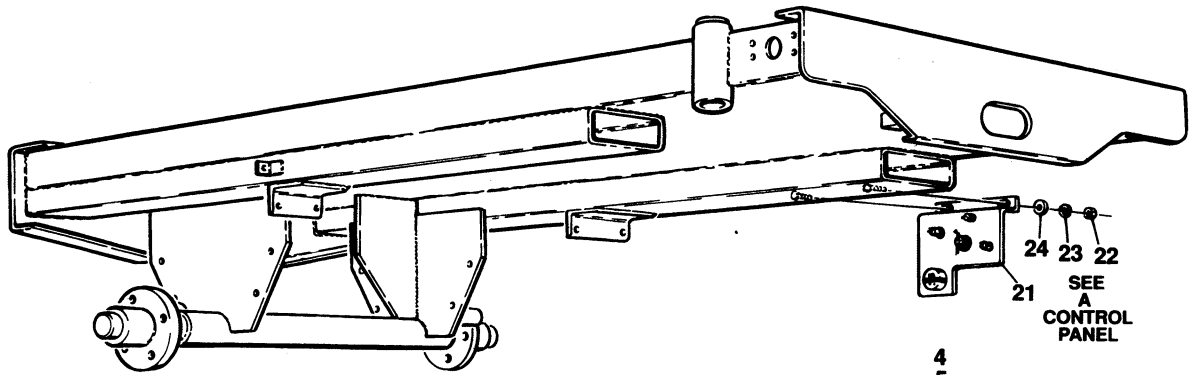

FIGURE 13-2-1. ELECTRICAL COMPONENTS INSTALLATION.

SECTION 13-2 GROUND COMPONENTS



**CONTROL PANEL**

**BATTERY CABLE CONNECTIONS**

# SECTION 13-2 GROUND COMPONENTS CM1432/CM1432 PLUS/CM1732

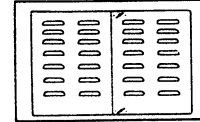

**SECTION 13 - 2 GROUND COMPONENTS**

FIGURE & ITEM NO	PART NUMBER	DESCRIPTION	QTY.	REV.
13-2-1		<b>ELECTRICAL COMPONENTS INSTALLATION</b>	Ref.	
	0252628/0254047	<b>ELECTRICAL COMPONENTS INSTALLATION (STANDARD)</b>	Ref.	H/O
—1	0400067	Battery (Wet)	4	
	0400113	Battery (Dry)	4	
—2	0181623	Angle - Left Side	1	
—3	0181622	Angle - Right Side	1	
—4	0641407	Bolt 1/4"-20NC x 7/8"	5	
—5	4751400	Flatwasher 1/4"	5	
—6	4761400	Lockwasher 1/4"	5	
—7	3311401	Nut 1/4"-20NC	5	
—8	0840031	Boot, Terminal	8	
—9	1060400	Cable, Battery (Battery Positive to Starter Relay)	1	
—10	1060221	Cable, Battery (Battery Positive to Battery Negative)	2	
—11	1060080	Cable, Battery (Master Switch to Ground)	1	
—12	1060221	Cable, Battery (Motor to Ground)	1	
—13	1060221	Cable, Battery (Motor to Starter Relay - Prior to August 1993) or (Motor to Fuse/Fuse to Relay - August 1993 to Present)	1	
—14	1060401	Cable, Battery (Battery Negative to Master Switch)	1	
—15	1060401	Cable, Battery (Left Side Battery Positive to Right Side Battery Negative)	1	
—16	3740068	Relay (Start)	1	
—17	0641407	Bolt 1/4"-20NC x 7/8"	2	
—18	4751400	Flatwasher 1/4"	2	
—19	4761400	Lockwasher 1/4"	2	
—20	3311401	Nut 1/4"-20NC	2	
—21	0252630	Control Panel Assembly (Includes Items 101-109)	1	—
—22	3311401	Nut 1/4"-20NC	2	
—23	4761400	Lockwasher 1/4"	2	
—24	4751400	Flatwasher 1/4"	2	
—25	2400044	Fuseholder (August 1993 to Present)	1	
—26	2400041	Fuse - 200 Amp (August 1993 to Present)	1	
—27	0741008	Screw, Countersunk #10 x 1" (August 1993 to Present)	2	
—28	0840025	Boot, Terminal (August 1993 to Present)	5	
	1282154	<b>CONTROL PANEL ASSEMBLY (STANDARD PARTS)</b>	Ref.	—
—101	3535820	Panel, Control	1	
—102	3252174	Nameplate - Ground Control	1	
—103	4360070	Breaker, Circuit - 15 Amp	1	
—104	Not Used			
—105	Not Used			
—106	Not Used			
—107	4360202	Switch, Toggle - DPDT/MC/CO (Lift)	1	
—108	2420116	Ammeter	1	
—109	4360155	Switch, Master (On/Off)	1	



# SECTION 13-2 GROUND COMPONENTS CM1432/CM1432 PLUS/CM1732

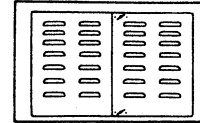

**SECTION 13-2 GROUND COMPONENTS**

FIGURE & ITEM NO	PART NUMBER	DESCRIPTION	QTY.	REV.
13—2—1		<b>ELECTRICAL COMPONENTS INSTALLATION (CONTINUED)</b>	Ref.	
	0252630	<b>CONTROL PANEL ASSEMBLY - PRIOR TO AUGUST 1993 (VARIABLE PARTS)</b>	Ref.	—
—151	4360290	Switch, Key (Select)	1	
	7010698	Key, Replacement	1 set	
—152	4360267	Block, Contact	1	
—153	4360281	Block, Contact	1	
	0254375	<b>CONTROL PANEL ASSEMBLY - AUGUST 1993 TO PRESENT (VARIABLE PARTS)</b>	Ref.	—
—151	4360319	Switch, Key (Select)	1	
	7012560	Key, Replacement	1 set	
—152	Not Required			
—153	Not Required			
		<b>ELECTRICAL DIAGRAM</b>	Ref.	
—201	4460277	Strip, Terminal - 14 Position	1	
—202	3911016	Screw, Machine #10-24NC x 1"	4	
—203	4751000	Flatwasher #10	5	
—204	4761000	Lockwasher #10	5	
—205	3311001	Nut #10-24NC	5	
—206	3740069	Relay	1	
—207	0751006	Screw, Machine #10-24NC x 3/4"	1	
	4761000	Lockwasher #10	1	
	3311001	Nut #10-24NC	1	
—208	4460007	Strip, Terminal - 6 Position	1	
		<b>HORN INSTALLATION (OPTIONAL)</b>	Ref.	
—301	0140022	Horn	1	
	0254884	<b>HOURLY METER AT GROUND INSTALLATION (NOT SHOWN)</b>	Ref.	A
	2900864	Hourmeter at Ground Kit	1	
	0902060	Bracket	1	
	4921665	Harness	1	
	2420106	Gauge, Hourmeter	1	

# SECTION 13-2 GROUND COMPONENTS CM1432/CM1432 PLUS/CM1732

FIGURE 13-2-2. HYDRAULIC COMPONENTS AND COVERS  
INSTALLATION.

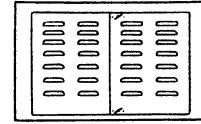

SECTION 13-2 GROUND COMPONENTS

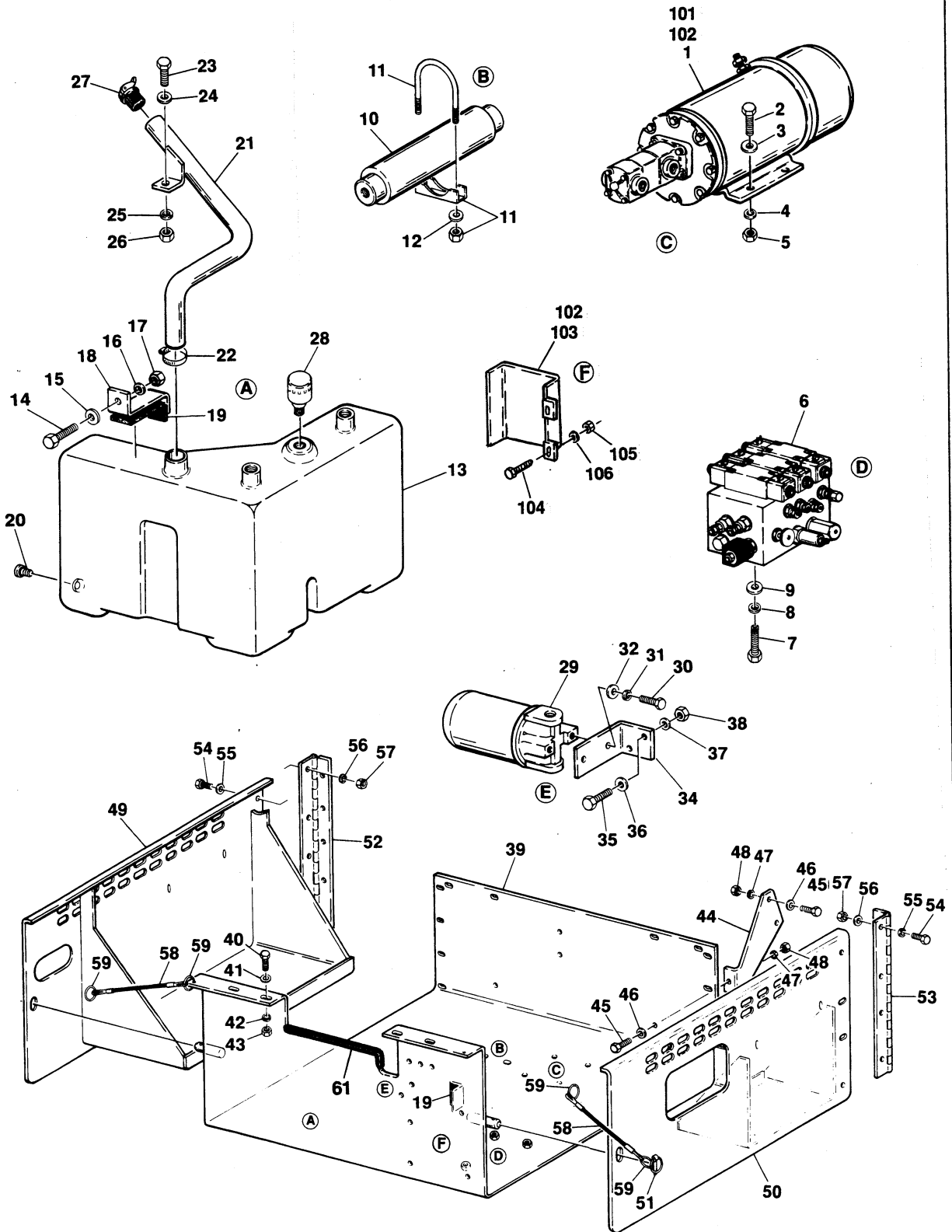

# SECTION 13-2 GROUND COMPONENTS CM1432/CM1432 PLUS/CM1732

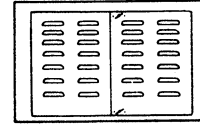

**SECTION 13 - 2 GROUND COMPONENTS**

FIGURE & ITEM NO	PART NUMBER	DESCRIPTION	QTY.	REV.
13-2-2		<b>HYDRAULIC COMPONENTS AND COVERS INSTALLATION</b>	Ref.	
	0252628/0254047	<b>MOTOR AND HYDRAULIC COMPONENTS INSTALLATION</b>	Ref.	H/D
—1	3600184	Pump/Motor Assembly	1	
	7010943	Electric Motor Assembly	1	
	7010640	Spring, Brush	8	
	7010639	Brush Set	2	
	7010951	Pump Assembly	1	
	7010944	Flex Coupling Kit	1	
—2	0641609	Bolt 3/8"-16NC x 1 1/8"	4	
—3	4751600	Flatwasher 3/8"	4	
—4	4761600	Lockwasher 3/8"	4	
—5	3311601	Nut 3/8"-16NC	4	
—6	4640733	Control Valve Assembly (See Figure 13-2-3 for Breakdown)	1	
—7	0641508	Bolt 5/16"-18NC x 1"	3	
—8	4761500	Lockwasher 5/16"	3	
—9	4751500	Flatwasher 5/16"	3	
—10	1682664	Cylinder, Cushion	1	
—11	1320185	Clamp, Muffler	1	
—12	4751500	Flatwasher 5/16"	2	
—13	4400337	Tank, Hydraulic	1	
—14	0641508	Bolt 5/16"-18NC x 1"	1	
—15	4751500	Flatwasher 5/16"	1	
—16	4761500	Lockwasher 5/16"	1	
—17	3311501	Nut 5/16"-18NC	1	
—18	0901792	Bracket, Mounting	1	
—19	4420038	Tape, Seal	1 ft./30.5cm	
—20	3520076	Plug, Magnetic	1	
	0100020	Sealant	A/R	
—21	4844289	Tube, Filler (Euro)	1	
	4565623	Tube, Filler (Australia)	1	
—22	1320033	Clamp	1	
—23	0641407	Bolt 1/4"-20NC x 7/8"	1	
—24	4751400	Flatwasher 1/4"	1	
—25	4761400	Lockwasher 1/4"	1	
—26	3311401	Nut 1/4"-20NC	1	
—27	3520077	Plug, Rubber	1	
—28	1340052	Breather	1	
	0100020	Sealant	A/R	
—29	2120105	Filter, Hydraulic	1	
	2120072	Element, Filter - 20 Micron (Standard)	1	
	2120148	Element, Filter - 10 Micron (Optional)	1	
—30	0641406	Bolt 1/4"-20NC x 3/4"	2	
—31	4761400	Lockwasher 1/4"	2	
—32	4751400	Flatwasher 1/4"	2	
—33	Not Used			
—34	0901831	Bracket, Filter	1	





# SECTION 13-2 GROUND COMPONENTS CM1432/CM1432 PLUS/CM1732

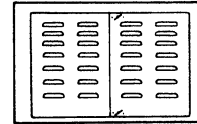

**SECTION 13 - 2 GROUND COMPONENTS**

FIGURE & ITEM NO	PART NUMBER	DESCRIPTION	QTY.	REV.
13—2—2		<b>HYDRAULIC COMPONENTS AND COVERS INSTALLATION (CONTINUED)</b>	Ref.	
—35	0641406	Bolt 1/4"-20NC x 3/4"	2	
—36	4751400	Flatwasher 1/4"	2	
—37	4761400	Lockwasher 1/4"	2	
—38	3311401	Nut 1/4"-20NC	2	
—39	4843909	Tray (Tray)	1	
	4844542	Tray (Australia)	1	
—40	0641609	Bolt 3/8"-16NC x 1 1/8"	8	
—41	4751600	Flatwasher 3/8"	8	
—42	4761600	Lockwasher 3/8"	8	
—43	3311601	Nut 3/8"-16NC	8	
—44	3535680	Plate, Support	2	
—45	0641609	Bolt 3/8"-16NC x 1 1/8"	3	
—46	0641600	Flatwasher 3/8"	3	
—47	4761600	Lockwasher 3/8"	3	
—48	3311601	Nut 3/8"-16NC	3	
—49	4843910	Door - Right Side	1	
—50	4843911	Door - Left Side	1	
—51	3421970	Pin, Clip	2	
—52	2600175	Hinge - Right Side	1	
—53	2600176	Hinge - Left Side	1	
—54	0641508	Bolt 5/16"-18NC x 1"	8	
—55	4751500	Flatwasher 5/16"	8	
—56	4761500	Lockwasher 5/16"	8	
—57	3311501	Nut 5/16"-18NC	8	
—58	1060380	Cable, Lanyard	2	
—59	3760170	Ring	4	
—60	Not Used			
—61	4060804	Flex-Trim	13 in./33cm	
—62	1320095	Clamp (Not Shown)	2	
—63	4280289	Strip, Cover (Located on top of frame)	1	
—64	4060853	Cover, Frame Tray (Located on top of frame)	1	
	0254480	<b>TUV COMPONENTS INSTALLATION</b>	Ref.	A
—101	2901207	Motor Band Kit	1	
—102	1702140	Decal - Ground	2	
—103	3536983	Cover	1	
—104	0641408	Bolt 1/4"-20NC x 1"	2	
—105	3311401	Nut 1/4"-20NC	2	
—106	4761400	Lockwasher 1/4"	2	

# SECTION 13-2 GROUND COMPONENTS CM1432/CM1432 PLUS/CM1732

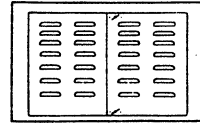
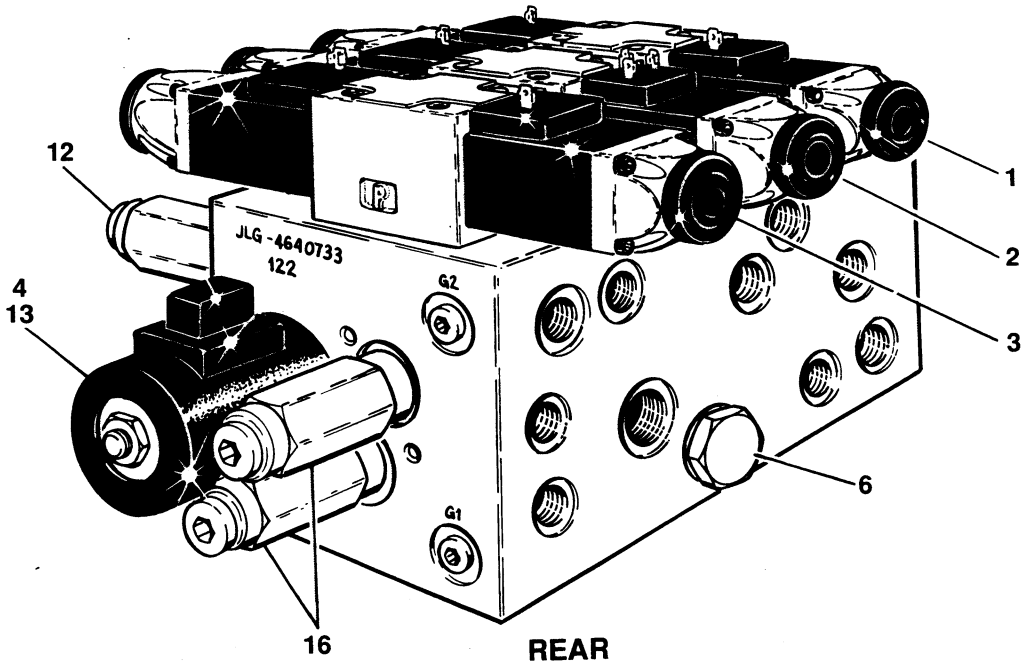
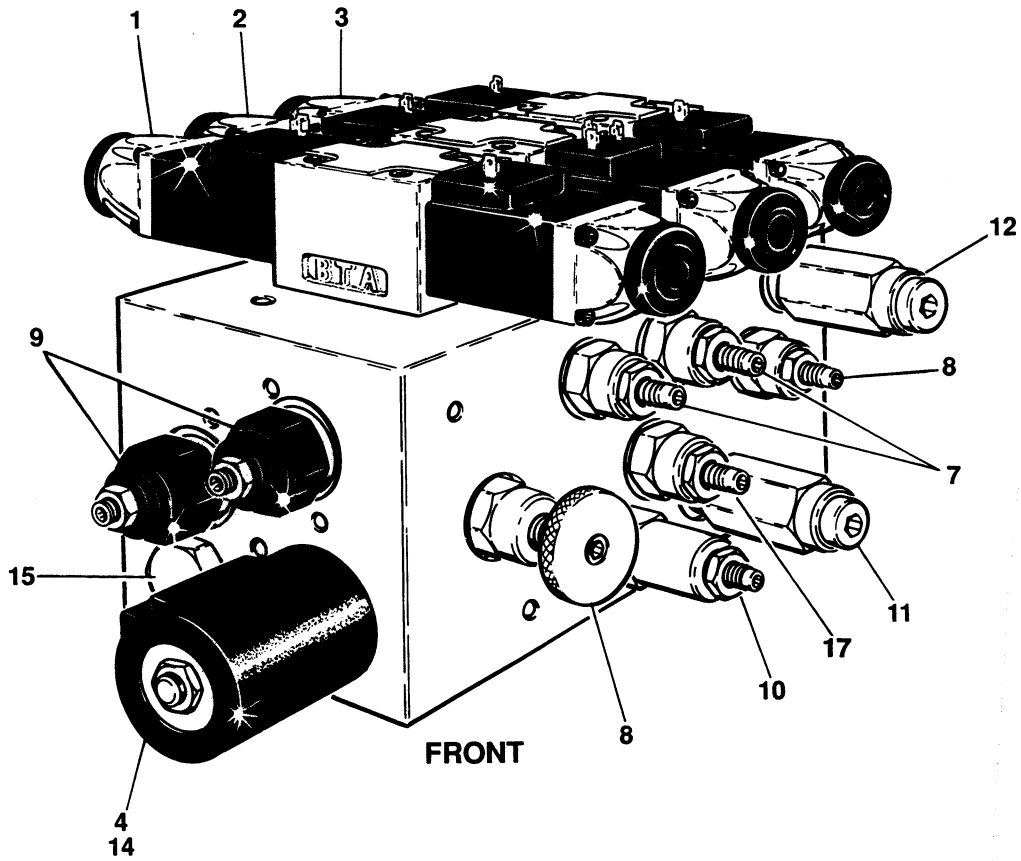
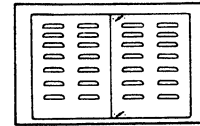

FIGURE 13-2-3. CONTROL VALVE ASSEMBLY - HYDRO-AIR.

SECTION 13-2 GROUND COMPONENTS



# SECTION 13-2 GROUND COMPONENTS CM1432/CM1432 PLUS/CM1732



**SECTION 13 - 2 GROUND COMPONENTS**

FIGURE & ITEM NO	PART NUMBER	DESCRIPTION	QTY.	REV.
13—2—3	4640733	<b>CONTROL VALVE ASSEMBLY - HYDRO-AIR (MACHINES WITH BANG-BANG DRIVE)</b>	Ref.	A
—1	4640737	Rexroth Directional Valve Assembly (Drive)	1	
	7012726	Coil (Rexroth)	2	
	7012725	Seal Kit (Rexroth)	1	
—2	4640745	Rexroth Directional Valve Assembly (Lift/Hi-Drive)	1	
	7012726	Coil - 1 Prong (Rexroth)	1	
	7012732	Coil - 3 Prong (Rexroth)	1	
	7012725	Seal Kit (Rexroth)	1	
—3	4640740	Rexroth Directional Valve Assembly (Steer)	1	
	7012727	Coil (Rexroth)	2	
	7012725	Seal Kit (Rexroth)	1	
—4	7012900	Coil - 20 Volt (Hydraforce)	2	
—5	Not Used			
—6	7012930	Valve, Check	1	
	2900756	Seal Kit (Hydraforce CV10-20-0-N-5)	1	
—7	7010544	Valve, Flow Control (Brake Speed and Lift/Lower Speed Adjustments)	2	
	7012901	Seal Kit (Hydraforce FC10-20A-0-N) (1 Per Cartridge)	2	
—8	7012933	Valve, Needle (Tow and Creep Adjustments)	2	
	7012901	Seal Kit (Hydraforce NV10-20A-0-N) (1 Per Cartridge)	2	
—9	7004361	Valve, Load Control (Drive Motion Adjustments)	2	
	2900706	Seal Kit (1 Per Cartridge)	2	
—10	7012934	Valve, Sequence (Hi-Drive Kickout Adjustment)	1	
	2900707	Seal Kit (Hydraforce PS10-32A-0-N-15/11)	1	
—11	7012932	Valve, Relief (P1 Relief Pressure Adjustment) (Hydraforce Version)	1	
	2900708	Seal Kit (Hydraforce RV10-20H-0-N-33/27)	1	
—12	7012932	Valve, Relief (P2 Relief Pressure Adjustment)	1	
	2900708	Seal Kit (Hydraforce RV10-20H-0-N-33/27)	1	
—13	7012920	Valve, Solenoid - Less Coil (Mid-Drive) (Hydraforce SV10-25-0-N-00) (Order Coil Separately)	1	
	2900708	Seal Kit	1	
—14	7012919	Valve, Solenoid - Less Coil (Positive Traction) (Hydraforce SV10-42-0-N-00) (Order Coil Separately)	1	

# SECTION 13-2 GROUND COMPONENTS CM1432/CM1432 PLUS/CM1732

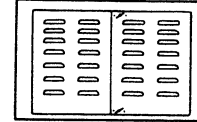

**SECTION 13-2 GROUND COMPONENTS**

FIGURE & ITEM NO	PART NUMBER	DESCRIPTION	QTY.	REV.
13—2—3	4640733	<b>CONTROL VALVE ASSEMBLY - HYDRO-AIR (MACHINES WITH BANG-BANG DRIVE) (CONTINUED)</b>	Ref.	A
	7012903	Seal Kit	1	
—15	7012929	Valve, Flow Divider	1	
	7012904	Seal Kit (Hydraforce FD10-40-0-N-44)		
—16	7012931	Valve, Relief (Steer Relief Adjustments)	2	
	2900708	Seal Kit (Hydraforce RV10-20H-N-33/15and RV10-26H-N-30/15) (1 Per Cartridge)	2	
—17	7012912	Valve, Relief (Lift Relief Pressure) (Machines Built after June 1993 Only)	1	
	7010541	Seal Kit (Hydraforce RV08-20A-0-N-33)	1	

**SECTION 13-3 SIZZOR ARMS  
CM1432/CM1432 PLUS/CM1732**

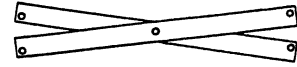

**TABLE OF CONTENTS**

FIGURE NO.	TITLE	PAGE NO.
13-3-1	Sizzor Arms Installation - CM1432 and CM1432 Plus .....	13-3-2
13-3-2	Sizzor Arms Installation - CM1732 .....	13-3-6
13-3-3	Arm Guards Installation (Prior to July 1992) .....	13-3-8
13-3-4	Arm Guards Installation (July 1992 to June 1995) .....	13-3-10
13-3-5	Arm Guards Installation (June 1995 to Present) .....	13-3-12

**S  
E  
C  
T  
I  
O  
N  
  
13  
-  
3  
  
S  
I  
Z  
Z  
O  
R  
  
A  
R  
M  
S**

# SECTION 13-3 SIZZOR ARMS CM1432/CM1432 PLUS/CM1732

FIGURE 13-3-1. SIZZOR ARMS INSTALLATION - CM1432  
AND CM1432 PLUS.

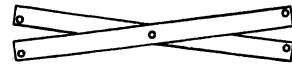

SECTION  
13 - 3  
SIZZOR  
ARMS

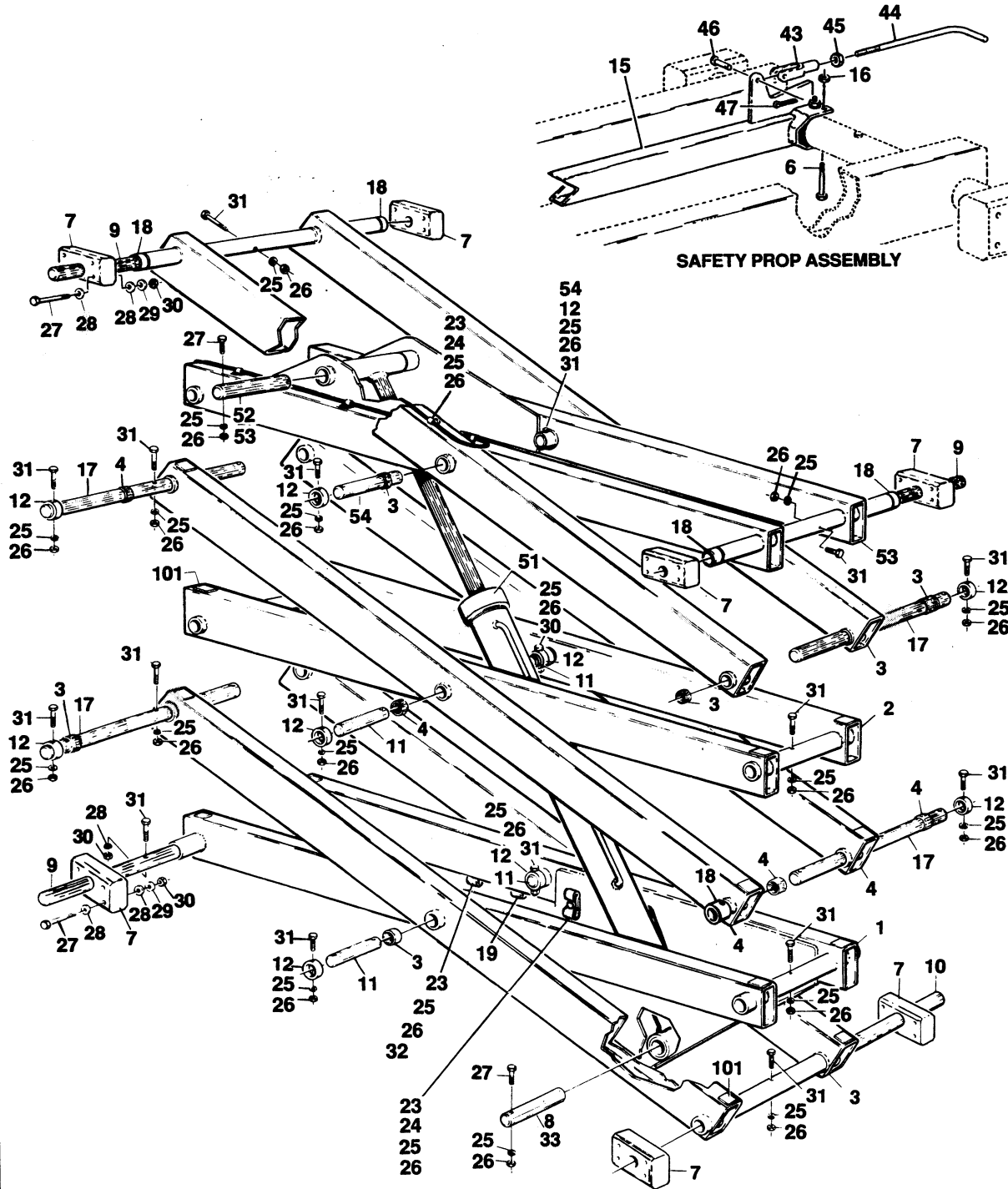

# SECTION 13-3 SIZZOR ARMS CM1432/CM1432 PLUS/CM1732

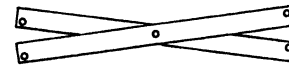

FIGURE & ITEM NO	PART NUMBER	DESCRIPTION	QTY.	REV.
13-3-1		<b>SIZZOR ARMS INSTALLATION - CM1432/CM1432 PLUS</b>	Ref.	
	1282052	<b>SIZZOR ARMS INSTALLATION (STANDARD PARTS)</b>	Ref.	E
	2901371	Arms Kit - CM1432	1	—
	2901373	Arms Kit - CM1432 PLUS	1	—
—1	0200510	Arm Weldment (Bottom Inboard)	1	
—2	0200438	Arm Weldment (Mid Inboard)	1	
—3	0200514	Arm Weldment (Top and Bottom Outboard)	2	
	0961560	Bushing, Excellite (4 Per Arm Weldment)	8	
—4	0200446	Arm Weldment (Mid Outboard - Left Side)	2	
	0961560	Bushing, Excellite (3 Per Arm)	6	
—5	Not Used			
—6	0641420	Bolt 1/4"-20NC x 2 1/2"	2	
—7	3340629	Pad, Slide Block	8	
—8	3421894	Pin, Cylinder Attach	2	
—9	3421895	Pin, Attach	3	
—10	3421896	Pin, Attach	1	
—11	3421897	Pin, Attach	4	
—12	1440231	Collar	14	
—13	Not Used			
—14	Not Used			
—15	4564106	Prop, Safety	1	
—16	3311405	Locknut 1/4"-20NC	2	
—17	3421976	Pin, Attach	4	
—18	0961566	Bushing Spacer	4	
—19	1320041	Clamp	1	
—20	Not Used			
—21	3311402	Nut, Jam 1/4"-20NC	7	
—22	Not Used			
—23	1320061	Clamp	10	
—24	4300038	Stud (Welded on Part)	7	
—25	4761500	Lockwasher 5/16"	10	
—26	3311501	Nut 5/16"-18NC	8	
—27	0641522	Bolt 5/16"-18NC x 2 3/4"	34	
—28	4751500	Flatwasher 5/16"	64	
—29	4711500	Flatwasher 5/16" Narrow	32	
—30	3311505	Locknut 5/16"-18NC	45	
—31	0641520	Bolt 5/16"-18NC x 2 1/2"	28	
—32	0641506	Bolt 5/16"-18NC x 3/4"	3	
—33	3020022	Grease	A/R	
—43	1360112	Clevis	1	
—44	3841211	Rod	1	
—45	3321402	Nut, Jam 1/4"-28NF	1	
—46	3430406	Pin, Clevis 1/4" x 3/4"	1	
—47	3450203	Pin, Cotter 1/16" x 3/4"	1	

SECTION 13 - 3 SIZZOR ARMS





# SECTION 13-3 SIZZOR ARMS CM1432/CM1432 PLUS/CM1732

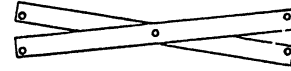
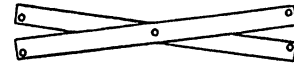

FIGURE & ITEM NO	PART NUMBER	DESCRIPTION	QTY.	REV.
13-3-1		<b>SIZZOR ARMS INSTALLATION - CM1432/CM1432 PLUS (CONTINUED)</b>	Ref.	
	0252673	<b>SIZZOR ARMS INSTALLATION - CM1432 (VARIABLE PARTS)</b>	Ref.	E
-51	1682505	Lift Cylinder Assembly (See Section 13-5 for Breakdown)	1	
-52	3421894	Pin, Cylinder Attach (Top)	1	
-53	0200510	Arm Weldment (Top Inboard)	1	
-54	3421897	Pin, Attach	2	
	0253905	<b>SIZZOR ARMS INSTALLATION - CM1432 PLUS (VARIABLE PARTS)</b>	Ref.	D
-51	1682907	Lift Cylinder Assembly (See Section 13-5 for Breakdown)	1	
-52	3422216	Pin, Cylinder Attach (Top)	1	
-53	0200511	Arm Weldment (Top Inboard)	1	
-54	3422284	Pin, Attach	2	
	0252586	<b>PAD INSTALLATION</b>	Ref.	—
-101	3340645	Pad	16	

SECTION 13-3 SIZZOR ARMS

# SECTION 13-3 SIZZOR ARMS CM1432/CM1432 PLUS/CM1732

FIGURE 13-3-2. SIZZOR ARMS INSTALLATION - CM1732,



SECTION 13-3 SIZZOR ARMS

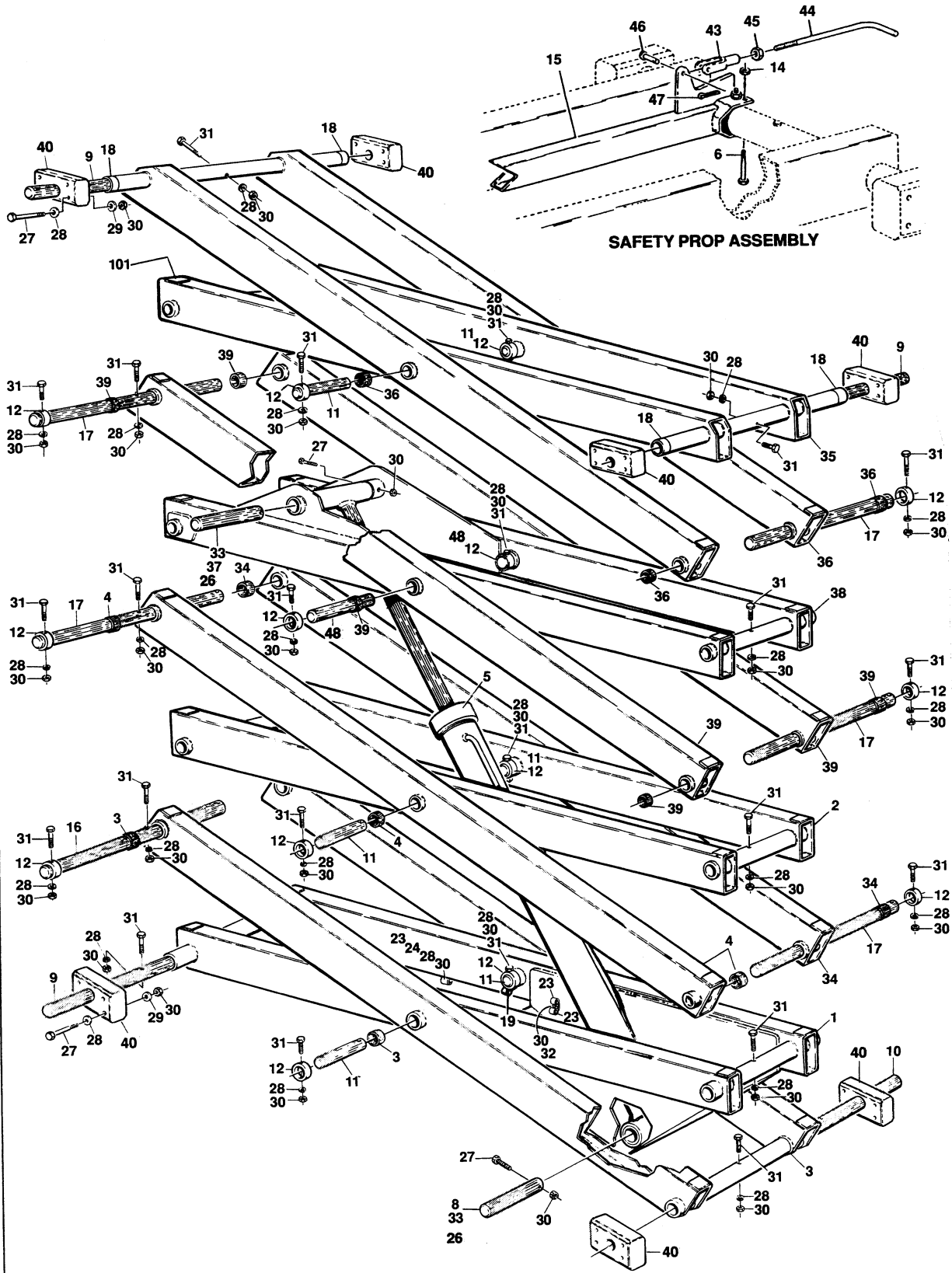

# SECTION 13-3 SIZZOR ARMS CM1432/CM1432 PLUS/CM1732

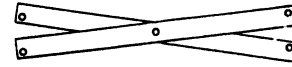
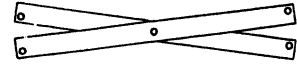

FIGURE & ITEM NO	PART NUMBER	DESCRIPTION	QTY.	REV.
13-3-2		<b>SIZZOR ARMS INSTALLATION - CM1732</b>	Ref.	
	0253907	<b>SIZZOR ARMS INSTALLATION (STANDARD PARTS)</b>	Ref.	F
	2901369	Arms Kit	1	—
—1	0200510	Arm Weldment (Bottom Inboard)	1	
—2	0200438	Arm Weldment (Lower Mid Inboard)	1	
—3	0200514	Arm Weldment (Bottom Outboard)	1	
	0961560	Bushing, Excellite	4	
—4	0200440	Arm Weldment (Lower Mid Outboard - Left Side)	1	
	0961560	Bushing, Excellite	3	
—5	1682907	Lift Cylinder Assembly (See Section 13-5 for Breakdown)	1	
—6	0641420	Bolt 1/4"-20NC x 2 1/2"	2	
—7	Not Used			
—8	3421894	Pin, Cylinder Attach (Bottom)	1	
—9	3421895	Pin, Attach	3	
—10	3421896	Pin, Attach	1	
—11	3421897	Pin, Attach	6	
—12	1440231	Collar	20	
—13	Not Used			
—14	3311405	Blocknut 1/4"-20NC	2	
—15	4564106	Drop, Safety	1	
—16	3421975	Pin, Attach	1	
—17	3421976	Pin, Attach	5	
—18	0961566	Bushing Spacer	4	
—19	1320041	Clamp	1	
-20 to -22	Not Used			
—23	1320061	Clamp	4	
—24	4300038	Stud (Welded on Part)	1	
—25	Not Used			
—26	2160002	Fitting, Grease	2	
—27	0641522	Bolt 5/16"-18NC x 2 3/4"	18	
—28	4751500	Flatwasher 5/16"	64	
—29	4711500	Flatwasher 5/16" Narrow	32	
—30	3311505	Locknut 5/16"-18NC	59	
—31	0641520	Bolt 5/16"-18NC x 2 1/2"	38	
—32	0641506	Bolt 5/16"-18NC x 3/4"	3	
—33	3020022	Grease	A/R	
—34	0200446	Arm Weldmt (Lower Mid Outboard-Right Side)(Part of Kit)	1	
	0961560	Bushing, Excellite	3	
—35	0200512	Arm Weldment (Top Inboard)(Part of Kit)	1	
—36	0200513	Arm Weldment (Top Outboard)(Part of Kit)	1	
	0961560	Bushing, Excellite	4	
—37	3422216	Pin, Cylinder Attach (Top)	1	
—38	0200509	Arm Weldment (Upper Mid Inboard)(Part of Kit)	1	
—39	0200446	Arm Weldment (Upper Mid Outboard)(Part of Kit)	2	
	0961560	Bushing, Excellite (3 Per Arm)	6	
—40	3340629	Pad, Slide Block	8	
—41	Not Used			
—42	Not Used			
—43	1360112	Clevis	1	
—44	3841211	Rod	1	
—45	3321402	Nut, Jam 1/4"-28NF	1	
—46	3430406	Pin, Clevis 1/4" x 3/4"	1	
—47	3450203	Pin, Cotter 1/16" x 3/4"	1	
—48	3482284	Pin, Attach	2	
	1281758	<b>PAD INSTALLATION</b>	Ref.	
—101	3340645	Pad	22	

SECTION 13-3 SIZZOR ARMS

# SECTION 13-3 SIZZOR ARMS CM1432/CM1432 PLUS/CM1732

FIGURE 13-3-3. ARM GUARD INSTALLATION.  
(PRIOR TO JULY 1992).



SECTION 13-3 SIZZOR ARMS

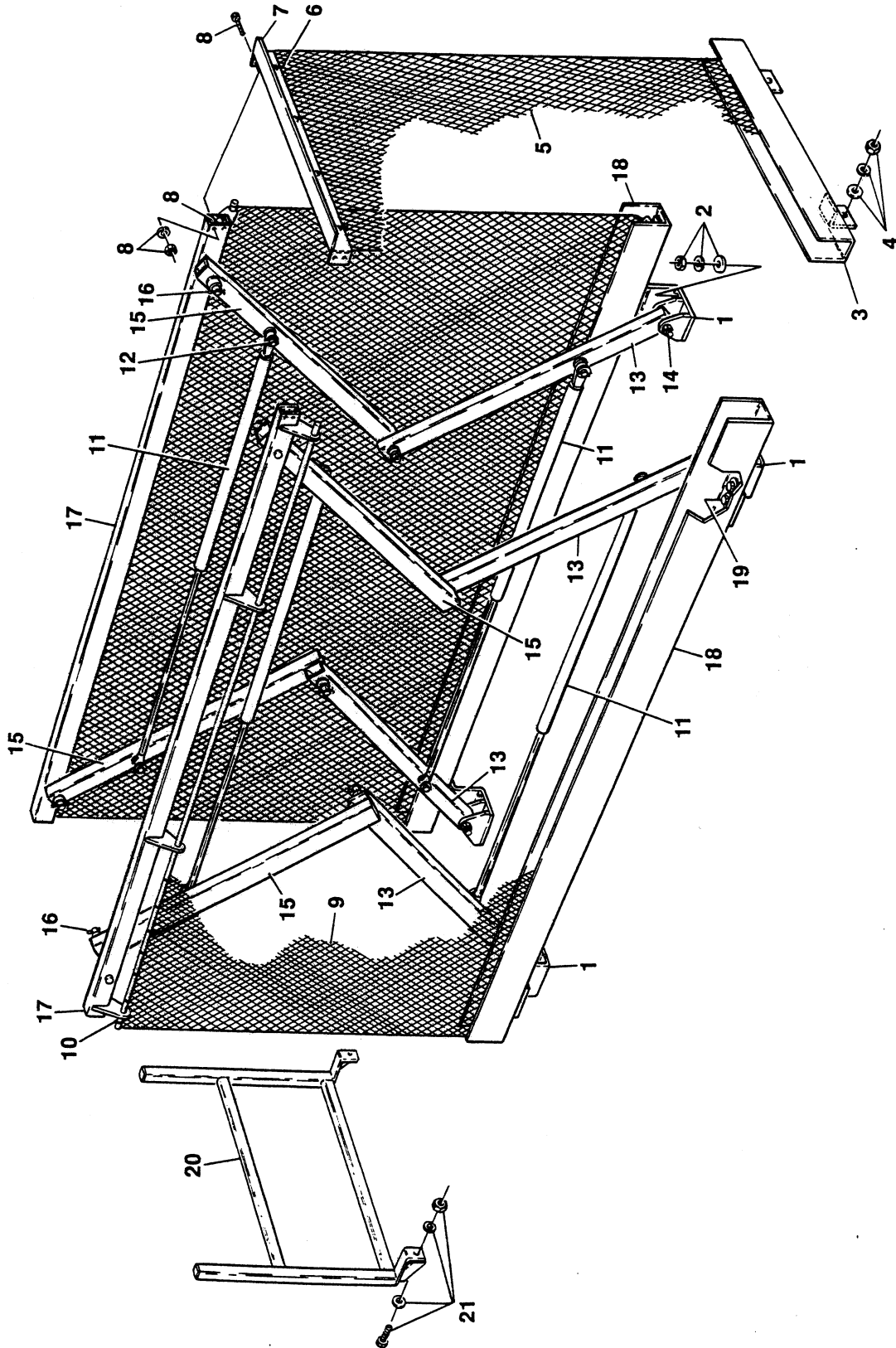

# SECTION 13-3 SIZZOR ARMS CM1432/CM1432 PLUS/CM1732

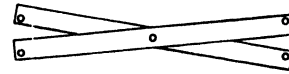
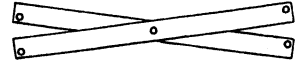

FIGURE & ITEM NO	PART NUMBER	DESCRIPTION	QTY.	REV.
13-3-3	0252665	ARM GUARD INSTALLATION (PRIOR TO JULY 1992)	Ref.	—
—1	4844100	Bracket	4	
—2	3311401	Nut 1/4"-20NC	2	
	4761400	Lockwasher 1/4"	2	
	4751400	Flatwasher 1/4"	2	
	4300068	Stud (Welded on Part)	2	
—3	4844104	Front Tray Weldment	1	
—4	3311501	Nut 5/16"-18NC	2	
	4761500	Lockwasher 5/16"	2	
	4751500	Flatwasher 5/16"	2	
	4300038	Stud (Welded on Part)	2	
—5	0840073	Belt - Wire Mesh	1	
—6	4240033	Tie - Strap	6	
—7	3535873	Plate - Front	1	
—8	0641412	Bolt 1/4"-20NC x 1 1/2"	4	
	4565559	Spacer, Tube	4	
	4761400	Lockwasher 1/4"	4	
	3311401	Nut 1/4"-20NC	4	
—9	0480072	Belt - Wire Mesh (Side)	2	
—10	4240033	Tie - Strap	24	
—11	4160102	Spring, Gas	4	
—12	3450404	Pin, Cotter 1/8" x 1"	2	
	4751500	Flatwasher 5/16"	4	
—13	4844098	Lower Tube Weldment	4	
—14	4844097	Upper Tube Weldment	4	
—15	0641820	Bolt 1/2"-13NC x 2 1/2"	3	
	0961627	Bearing, Flanged	6	
	4751800	Flatwasher 1/2"	3	
	3311405	Locknut 1/2"-13NC	3	
—16	4844099	Top Frame Weldment	2	
—17	3535874	Side Tray Weldment	2	
—18	3311401	Nut 1/4"-20NC	2	
	4761400	Lockwasher 1/4"	2	
	4751400	Flatwasher 1/4"	2	
	4300068	Stud (Welded on Part)	2	
—19	0901755	Bracket Weldment - Ladder	2	
	3520071	Cap, Plastic	2	
—20	0641610	Bolt 3/8"-16NC x 1 1/4"	1	
	4751600	Flatwasher 3/8"	1	
	4761600	Lockwasher 3/8"	1	
	3311601	Nut 3/8"-16NC	1	
	2901400	Repair Kit - Complete	1	—

SECTION 13 - 3 SIZZOR ARMS

# SECTION 13-3 SIZZOR ARMS CM1432/CM1432 PLUS/CM1732

FIGURE 13-3-4. ARM GUARD INSTALLATION.  
(JULY 1992 TO JUNE 1995).



SECTION 13-3 SIZZOR ARMS

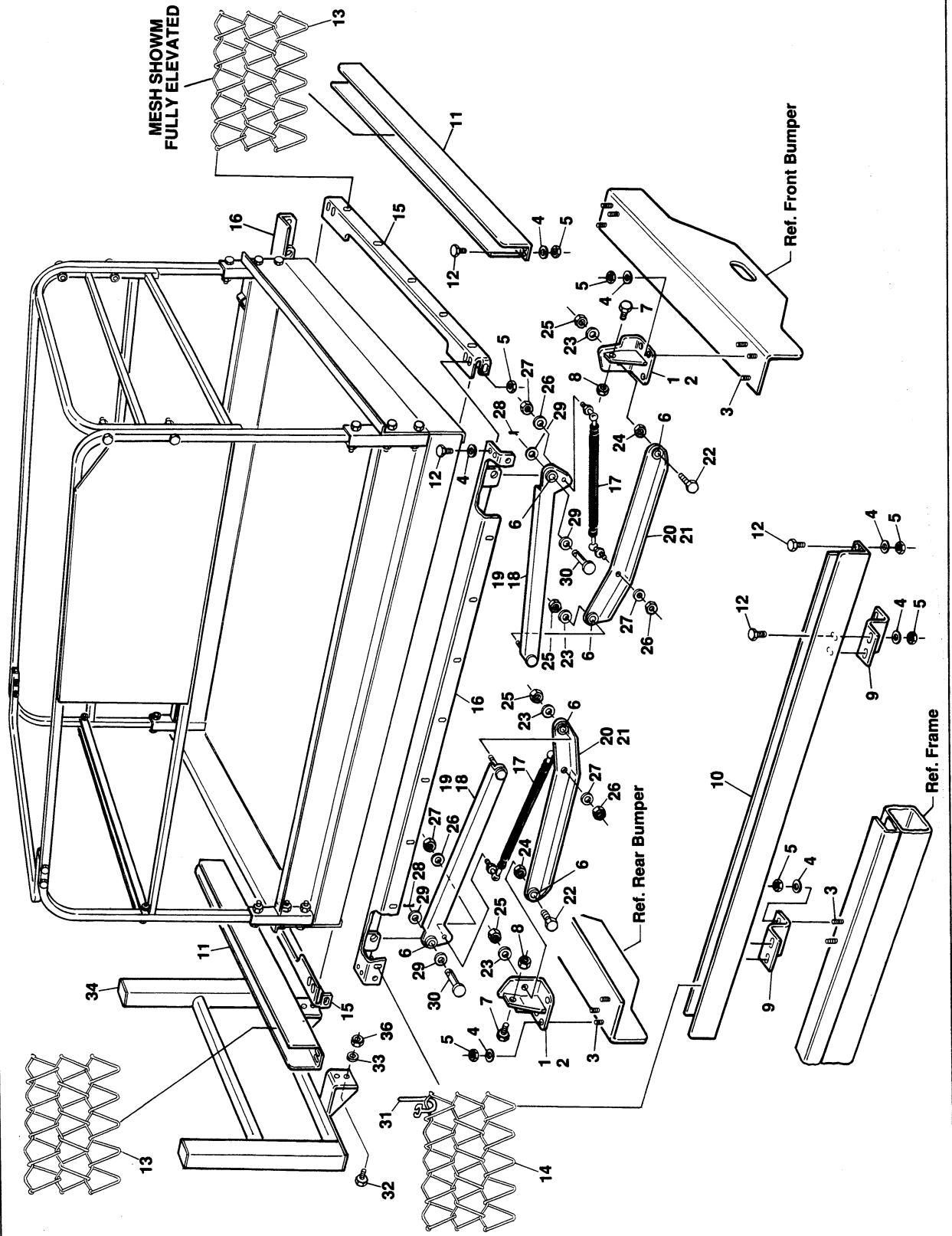

# SECTION 13-3 SIZZOR ARMS CM1432/CM1432 PLUS/CM1732

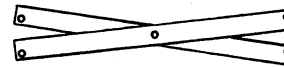

FIGURE & ITEM NO	PART NUMBER	DESCRIPTION	QTY.	REV.
13-3-4	0253412	<b>ARM GUARDS INSTALLATION ( JULY 1992 TO JUNE 1995)</b>	Ref.	E
—1	0901891	Bracket, Arm Guard (Right Side - Front and Left Side - Rear)	2	
—2	0901892	Bracket, Arm Guard (Left Side - Front and Right Side - Rear)	2	
—3	4300032	Stud (Welded on Part)	24	
—4	4751400	Flatwasher 1/4"	84	
—5	3311405	Locknut 1/4"-20NC	56	
—6	3020010	Lubricant, Never-Seez	A/R	
—7	0641608	Bolt 3/8"-16NC x 1"	4	
—8	3311605	Nut 3/8"-16NC	4	
—9	0901833	Bracket	4	
—10	3536403	Tray - Side	2	
—11	3536402	Tray - Front and Rear	2	
—12	0641606	Bolt 3/8"-16NC x 3/4"	32	
—13	0480073	Belt, Wire Meash - Front and Rear	2	
—14	0480072	Belt, Wire Mesh - Sides	2	
—15	0181683	Angle	2	
—16	4844288	Channel, Side	2	
—17	4160106	Spring, Gas	4	
—18	4844262	Arm Weldment - Upper (Left Side - Front and Right Side - Rear)	2	
—19	4844261	Arm Weldment - Upper (Right Side - Front and Left Side - Rear)	2	
—20	4844259	Arm Weldment - Lower (Left Side - Front and Right Side - Rear)	2	
—21	4844260	Arm Weldment - Lower (Right Side - Front and Left Side - Rear)	2	
—22	0641814	Bolt 1/2"-13NC x 1 3/4"	4	
—23	4740128	Washer, Bronze	12	
—24	3311802	Nut, Jam 1/2"-13NC	4	
—25	3311805	Locknut 1/2"-13NC	8	
—26	4751500	Flatwasher 5/16"	8	
—27	3311505	Locknut 5/16"-18NC	8	
—28	3430810	Pin, Clevis 1/2" x 1 1/4"	4	
—29	4751800	Flatwasher 1/2"	4	
—30	3450404	Pin, Cotter 1/8" x 1"	4	
—31	4240033	Tie - Strap	60	
—32	0641610	Bolt 3/8"-16NC	4	
—33	4751600	Flatwasher 3/8"	8	
—34	4844801	Ladder Weldment	1	
	3520071	Cap, Plastic	2	
—35	3537317	Plate, Stop (Not Shown - Located at Corners of Items 15 and 16)	4	
—36	3311605	Locknut 3/8"-16NC	4	
	2901400	Repair Kit - Complete	1	—

SECTION 13-3 SIZZOR ARMS

# SECTION 13-3 SIZZOR ARMS CM1432/CM1432 PLUS/CM1732

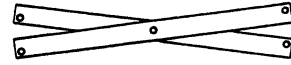
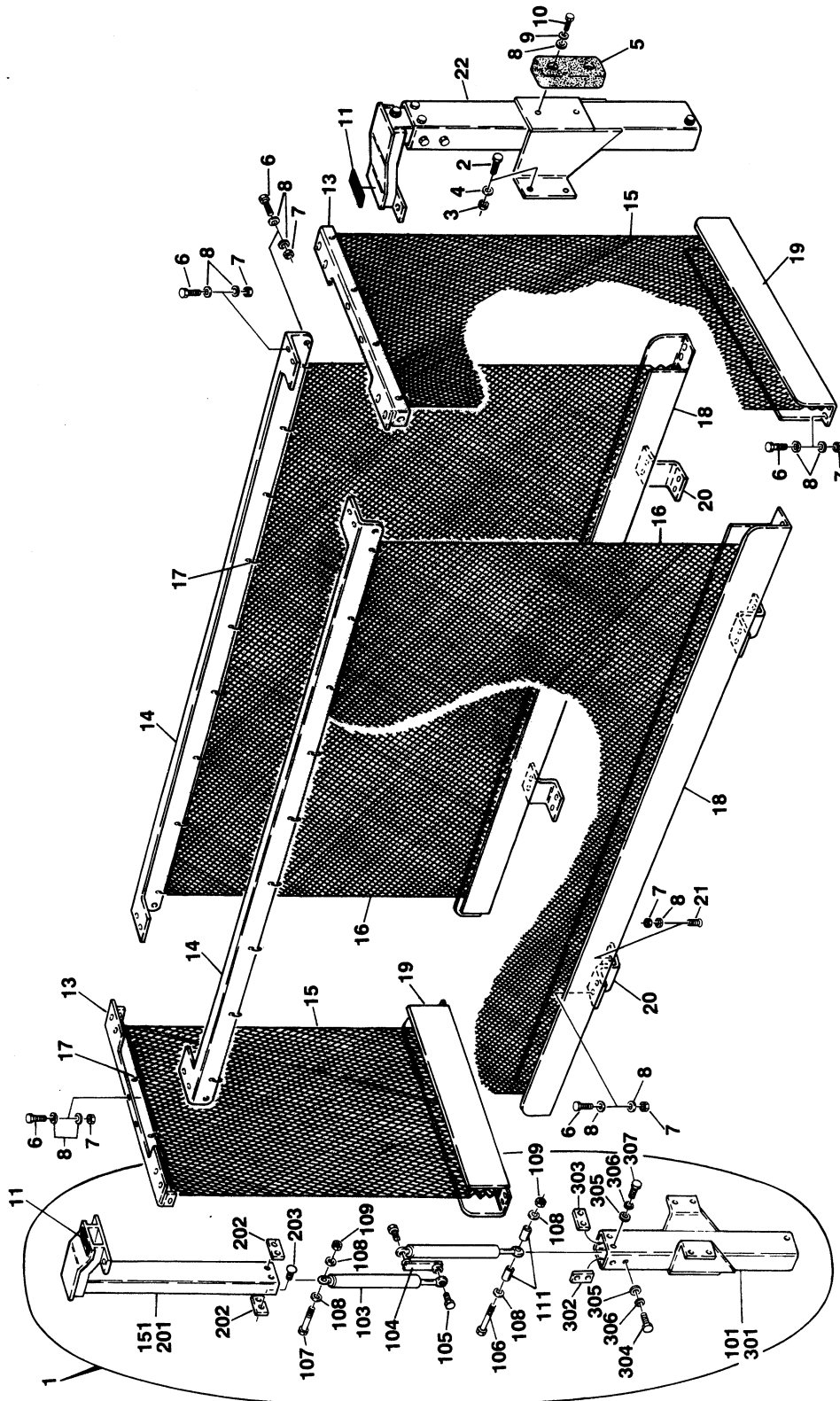

FIGURE 13-3-5. ARM GUARD INSTALLATION.  
(JUNE 1995 TO PRESENT).



SECTION 13-3 SIZZOR ARMS



# SECTION 13-3 SIZZOR ARMS CM1432/CM1432 PLUS/CM1732

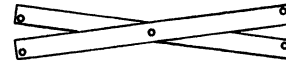
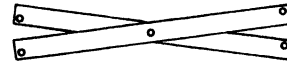

FIGURE & ITEM NO	PART NUMBER	DESCRIPTION	QTY.	REV.
13-3-5		<b>ARM GUARDS INSTALLATION (JUNE 1995 TO PRESENT)</b>	Ref.	
	0255572	<b>ARM GUARDS INSTALLATION</b>	Ref.	A
—1	0255574	Telescopic Tube Assembly - Rear (See Items 101-151 for Breakdown)	1	
—2	0641608	Bolt 3/8"-16NC x 1"	8	
—3	3311605	Locknut 3/8"-16NC	8	
—4	4751600	Flatwasher 3/8"	8	
—5	0940042	Bumper	1	
—6	0641406	Bolt 1/4"-20NC x 3/4"	30	
—7	3311405	Locknut 1/4"-20NC	44	
—8	4751400	Flatwasher 1/4"	64	
—9	0641410	Bolt 1/4"-20NC x 1 1/4"	2	
—10	4761400	Lockwasher 1/4"	2	
—11	4420055	Tape, UHMW	6in/15cm	
—12	Not Used			
—13	0181799	Angle, End	2	
—14	0181808	Angle, Side	2	
—15	0480073	Belt, Wire Mesh - End	2	
—16	0480072	Belt, Wire Mesh - Side	2	
—17	4240033	Tie-Strap	56	
—18	3536403	Tray, Side	2	
—19	3536402	Tray, End	2	
—20	0901833	Bracket	4	
—21	4300032	Stud (Welded on Part)	16	
—22	0255577	Telescopic Tube Assembly - Front (See Items 101-151 for Breakdown)	1	
		<b>TELESCOPIC TUBE ASSEMBLIES (STANDARD PARTS)</b>	Ref.	
—101	0255576	Outer Tube Assembly (See Items 301-306 for Breakdown)	1	
—102	Not Used			
—103	4160136	Spring, Gas	2	
—104	4845013	Link	1	
—105	0641508	Bolt 5/16"-18NC x 1"	2	
—106	0641524	Bolt 5/16"-18NC x 3"	1	
—107	0641516	Bolt 5/16"-18NC x 2"	1	
—108	4751500	Flatwasher 5/16"	4	
—109	3311505	Locknut 5/16"-18NC	2	
—110	0100011	Loctite (Not Shown)	A/R	
—111	0961378	Bushing	2	
	0255574	<b>TELESCOPIC TUBE ASSEMBLY - REAR (VARIABLE PARTS)</b>	Ref.	—
—151	0255579	Inner Tube Assembly (See Items 201-203 for Breakdown)	1	

SECTION 13 - 3 SIZZOR ARMS

# SECTION 13-3 SIZZOR ARMS CM1432/CM1432 PLUS/CM1732



**SECTION 13-3 SIZZOR ARMS**

FIGURE & ITEM NO	PART NUMBER	DESCRIPTION	QTY.	REV.
13-3-5		<b>ARM GUARDS INSTALLATION (JUNE 1995 TO PRESENT)</b>	Ref.	
	0255577	<b>TELESCOPIC TUBE ASSEMBLIES - FRONT (VARIABLE PARTS)</b>	Ref.	A
—151	0255591	Inner Tube Assembly (See Items 201-203 for Breakdown)	1	
	0255579	<b>INNER TUBE ASSEMBLY - REAR</b>	Ref.	B
—201	4845015	Inner Tube Weldment - Rear	1	
—202	3340780	Pad, Wear	2	
—203	3900213	Screw, Button Head	4	
	0255591	<b>INNER TUBE ASSEMBLY - FRONT</b>	Ref.	A
—201	4845011	Inner Tube Weldment - Rear	1	
—202	3340780	Pad, Wear	2	
—203	3900213	Screw, Button Head	4	
	0255576	<b>OUTER TUBE ASSEMBLY</b>	Ref.	
—301	4845012	Outer Tube Weldment	1	
—302	3340781	Pad, Wear	2	
—303	3340780	Pad, Wear	2	
—304	0641604	Bolt 3/8"-16NC x 1/2"	8	
—305	4751600	Flatwasher 3/8"	8	
—306	4761600	Lockwasher 3/8"	8	

# SECTION 13-4 PLATFORM

## CM2033/CM2046/CM2546/CM2558

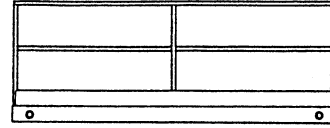

### TABLE OF CONTENTS

FIGURE NO.	DESCRIPTION	PAGE NO.
13-4-1	Platform and Handrail Installation . . . . .	13-4-2
13-4-2	Optional Platform Extension Installation with Standard Handrails . . . . .	13-4-6
13-4-2A	Optional Platform Extension Installation with Fold-Down Handrails . . . . .	13-4-8
13-4-3	Steel Platform Console Box Assembly . . . . .	13-4-10
13-4-4	Molded Platform Console Box Assembly . . . . .	13-4-14

SECTION  
13 - 4  
PLATFORM

# SECTION 13-4 PLATFORM CM1432/CM1432 PLUS/CM1732

FIGURE 13-4-1. PLATFORM AND HANDRAILS INSTALLATIONS.

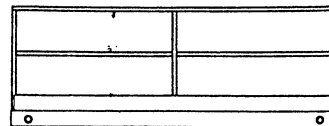

SECTION 13-4 PLATFORM

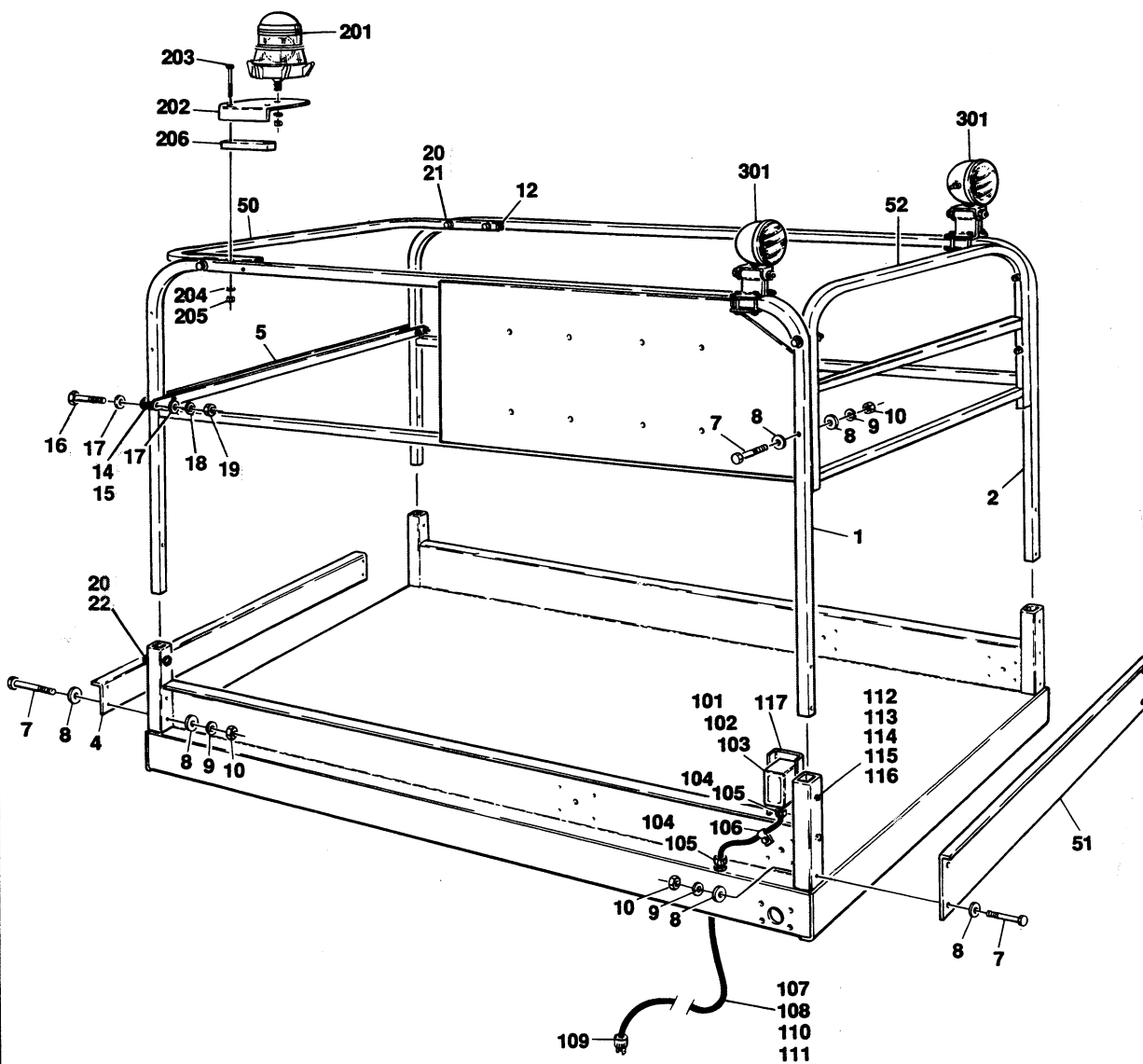

# SECTION 13-4 PLATFORM CM1432/CM1432 PLUS/CM1732

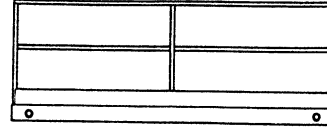
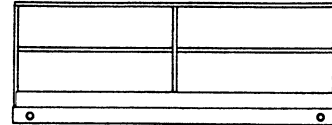

FIGURE & ITEM NO	PART NUMBER	DESCRIPTION	QTY.	REV.
13-4-1		<b>PLATFORM AND HANDRAIL INSTALLATIONS</b>	Ref.	
	3510338	Platform Weldment (CM1432 Built Prior to May 1993)	1	
	3510412	Platform Weldment - Fixed (CM1432 Built May 1993 to Present/All CM1432 Plus/All CM1732)	1	
	3510413	Platform Weldment - With Extension (CM1432 Built May 1993 to Present/All CM1432 Plus/All CM1732)	1	
	1281599	<b>HANDRAILS INSTALLATION (STANDARD PARTS)</b>	Ref.	D
-1	3640750	Handrail Weldment - Right Side	1	
-2	3640751	Handrail Weldment - Left Side	1	
-3	Not Used			
-4	3533370	Kickplate - Rear	1	
-5	3640614	Gate, Slide	1	
-6	0641420	Bolt 1/4"-20NC x 2 1/2"	2	
-7	0641424	Bolt 1/4"-20NC x 3"	A/R	
-8	4711400	Flatwasher 1/4" Narrow	A/R	
-9	4761400	Lockwasher 1/4"	A/R	
-10	3311401	Nut 1/4"-20NC	A/R	
-11	Not Used			
-12	3520072	Plug, Cap	2	
-13	Not Used			
-14	0961833	Bushing	4	
-15	4420055	Tape	A/R	
-16	3911034	Screw, Machine #10-24NC x 2 1/4"	4	
-17	4751000	Flatwasher #10	4	
-18	4761000	Lockwasher #10 (When Equipped)	4	
-19	3311005	Locknut #10-24NC	4	
-20	3900184	Screw, Buttonhead #10-24NC x 5/8"	8	
-21	3300374	Nut, Joint Connector 1 7/8	4	
-22	3300375	Nut, Joint Connector 2 3/8"	4	
	0251972	<b>HANDRAILS INSTALLATION - FIXED PLATFORM (VARIABLE PARTS)</b>	Ref.	D
-50	4565201	Tube - Rear	1	
-51	3534682	Kickplate - Front	1	
-52	3640796	Handrail - Front	1	
	0251973	<b>HANDRAILS INSTALLATION - EXTENDABLE PLATFORM (VARIABLE PARTS)</b>	Ref.	C
-50	4565285	Tube - Rear	1	
-51	Not Required			
-52	Not Required			

**SECTION 13 - 4 PLATFORM**

# SECTION 13-4 PLATFORM CM1432/CM1432 PLUS/CM1732



**SECTION 13-4 PLATFORM**

FIGURE & ITEM NO	PART NUMBER	DESCRIPTION	QTY.	REV.
13-4-1		<b>PLATFORM AND HANDRAIL INSTALLATIONS (CONTINUED)</b>	Ref.	
	0252374	<b>OPTIONAL 110 VOLT RECEPTACLE INSTALLATION - CM1432</b>	Ref.	C
	0254037	<b>OPTIONAL 110 VOLT RECEPTACLE INSTALLATION - CM1732</b>	Ref.	A
—101	Supply Locally	Box, Receptacle	1	
—102	Supply Locally	Receptacle, Electrical	1	
—103	Supply Locally	Cover, Weatherproof	1	
—104	4460049	Connector, Strain Relief	2	
—105	0960407	Bushing, Reducer	2	
—106	1320061	Clamp	2	
—107	1060308	Cable, Electrical - 12/3	A/R	
—108	4240033	Tie-Strap	10	
—109	Supply Locally	Plug, Connector	1	
—110	1700598	Decal - Ground (Wire Marker)	2	
—111	1700599	Decal - Neutral (Wire Marker)	2	
—112	0641420	Bolt 1/4"-20NC x 2 1/2"	1	
—113	4751400	Flatwasher 1/4"	3	
—114	4761400	Lockwasher 1/4"	3	
—115	3311401	Nut 1/4"-20NC	3	
—116	0641406	Bolt 1/4"-20NC x 3/4"	2	
—117	3535681	Plate, Mounting - Receptacle Box	1	
	0254376	<b>OPTIONAL 220 VOLT RECEPTACLE INSTALLATION - CM1432</b>	Ref.	—
	0254377	<b>OPTIONAL 220 VOLT RECEPTACLE INSTALLATION - CM1732</b>	Ref.	—
—101	0860038	Box, Receptacle	1	
—102	Supply Locally	Receptacle, Electrical	1	
—103	4060092	Cover, Weatherproof	1	
—104	4460049	Connector, Strain Relief	2	
—105	0960407	Bushing, Reducer	2	
—106	1320061	Clamp	2	
—107	1060308	Cable, Electrical - 12/3	A/R	
—108	4240033	Tie-Strap	10	
—109	Supply Locally	Plug, Connector	1	
—110	1700598	Decal - Ground (Wire Marker)	2	
—111	1700599	Decal - Neutral (Wire Marker)	2	
—112	0641420	Bolt 1/4"-20NC x 2 1/2"	1	
—113	4751400	Flatwasher 1/4"	3	
—114	4761400	Lockwasher 1/4"	3	
—115	3311401	Nut 1/4"-20NC	3	
—116	0641406	Bolt 1/4"-20NC x 3/4"	2	
—117	3535681	Plate, Mounting - Receptacle Box	1	

# SECTION 13-4 PLATFORM CM1432/CM1432 PLUS/CM1732

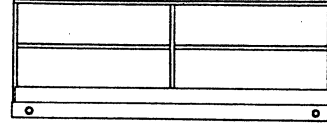
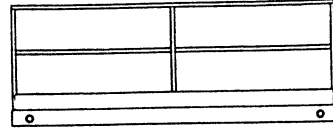

FIGURE & ITEM NO	PART NUMBER	DESCRIPTION	QTY.	REV.
13-4-1		<b>PLATFORM AND HANDRAIL INSTALLATIONS (CONTINUED)</b>	Ref.	
	0253474	<b>OPTIONAL BEACON LIGHT INSTALLATION (CM1432) (AMBER)</b>	Ref.	—
	0254032	<b>OPTIONAL BEACON LIGHT INSTALLATION (CM1732) (AMBER)</b>	Ref.	—
—201	2920087	Light, Beacon (Amber)	1	
—202	0901546	Bracket, Mounting	1	
—203	0641418	Bolt 1/4"-20NC x 2 1/4"	2	
—204	4761400	Lockwasher 1/4"	2	
—205	3311401	Nut 1/4"-20NC	2	
—206	0362063	Bar, Spacer	1	
	1060300	----- Cable, Electrical - 16/3	A/R	
	0253502	<b>OPTIONAL WORKLIGHTS INSTALLATION (CM1432)</b>	Ref.	—
	0254038	<b>OPTIONAL WORKLIGHTS INSTALLATION (CM1732)</b>	Ref.	—
—301	2920093	Lamp	2	
	1060341	Cable, Electrical - 16/2	A/R	

SECTION 13 - 4 PLATFORM

# SECTION 13-4 PLATFORM CM1432/CM1432 PLUS/CM1732

FIGURE 13-4-2. OPTIONAL PLATFORM EXTENSION  
INSTALLATION.



SECTION 13-4 PLATFORM

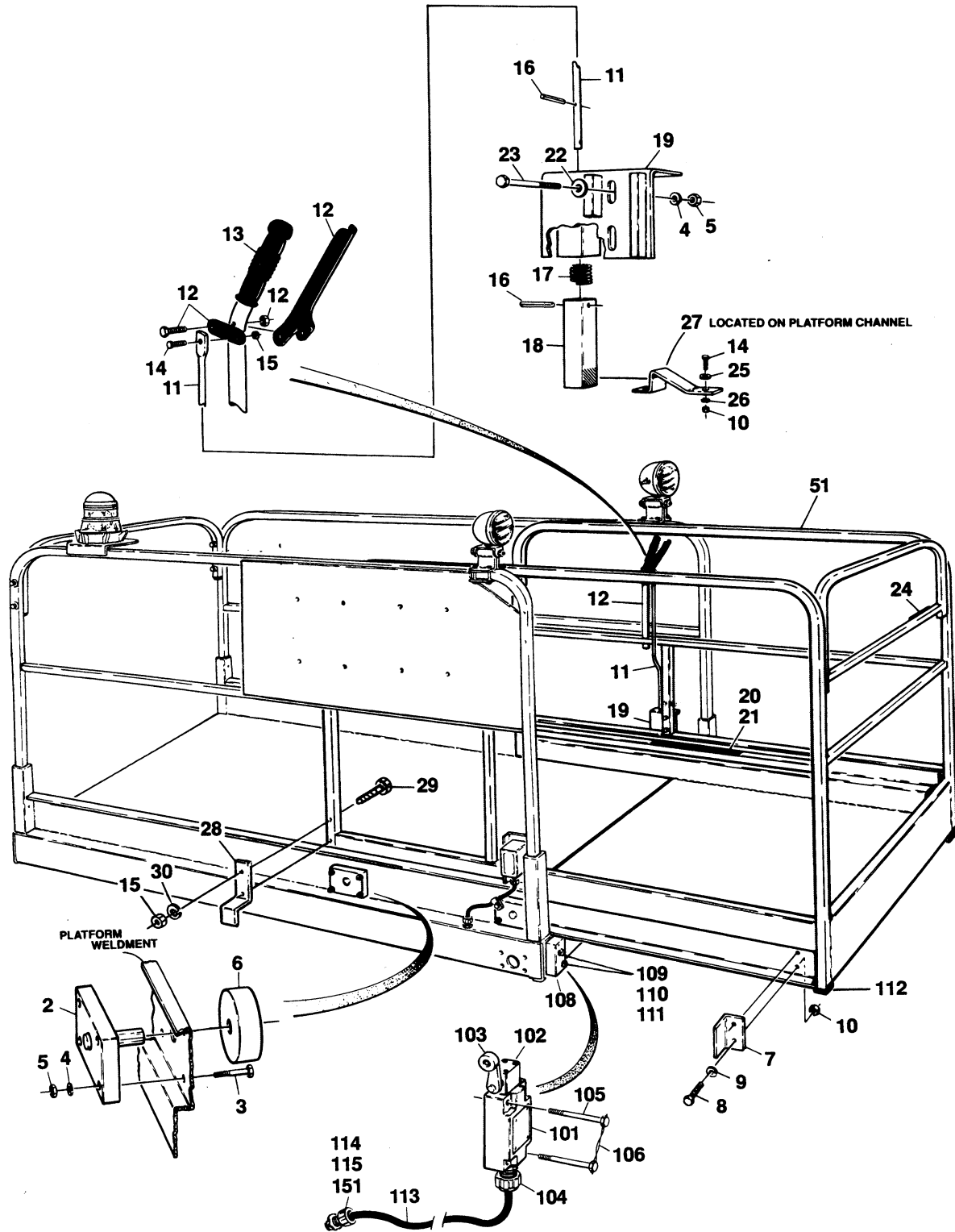



# SECTION 13-4 PLATFORM CM1432/CM1432 PLUS/CM1732

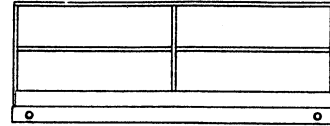

**SECTION 13 - 4 PLATFORM**

FIGURE & ITEM NO	PART NUMBER	DESCRIPTION	QTY.	REV.
13-4-2		<b>OPTIONAL PLATFORM EXTENSION INSTALLATION</b>	Ref.	
	1281791	<b>OPTIONAL PLATFORM EXTENSION INSTALLATION (STANDARD PARTS)</b>	Ref.	
-1	Not Used			
-2	4843706	Mount, Roller	4	
-3	0641508	Bolt 5/16"-18NC x 1"	16	
-4	4751500	Flatwasher 5/16"	18	
-5	3311501	Nut 5/16"-18NC	18	
-6	3860052	Roller	4	
	4712200	Shim, Flatwasher (Steel)	A/R	
	4740066	Shim, Flatwasher (Thin Bronze)	A/R	
-7	0181684	Stop, Angle	4	
-8	0641408	Bolt 1/4"-20NC x 1"	8	
-9	4761400	Lockwasher 1/4"	12	
-10	3311401	Nut 1/4"-20NC	12	
-11	3841074	Rod, Release	1	
-12	2980113	Lever, Release	1	
-13	2560088	Grip, Handle	1	
-14	0641406	Bolt 1/4"-20NC x 3/4"	5	
-15	3311405	Locknut 1/4"-20NC	3	
-16	3440413	Rollpin 1/8" x 13/16"	2	
-17	4160078	Spring	1	
-18	0361912	Block, Latch	1	
-19	2940061	Latch, Weldment	1	
-20	3251852	Nameplate - Capacity	1	
-21	3820001	Rivet	2	
-22	4751500	Flatwasher 5/16"	4	
-23	0641516	Bolt 5/16"-18NC x 2"	2	
-24	3252136	Nameplate - Control Box Location	1	
-25	4711400	Flatwasher 1/4" Narrow	4	
-26	4791400	Starwasher 1/4"	4	
-27	0901830	Bracket, Latch	2	
-28	0901906	Bracket, Retaining	2	
-29	0641416	Bolt 1/4"-20NC x 2"	2	
-30	4751400	Flatwasher 1/4"	4	
	0252065	<b>OPTIONAL PLATFORM EXTENSION INSTALLATION (PRIOR TO JUNE 1992) (VARIABLE PARTS)</b>	Ref.	A
-51	3510352	Extension Weldment	1	
	0252738	<b>OPTIONAL PLATFORM EXTENSION INSTALLATION (JUNE 1992 TO PRESENT) (VARIABLE PARTS)</b>	Ref.	C
-51	3510493	Extension Weldment	1	
		<b>PLATFORM EXTENSION LIMIT SWITCHES INSTALLATION (FRENCH AND ITALIAN SPECS)</b>	Ref.	
-101	4360277	Switch, Limit	1	



# SECTION 13-4 PLATFORM CM1432/CM1432 PLUS/CM1732

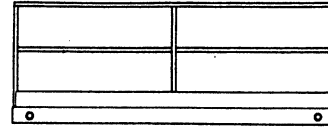
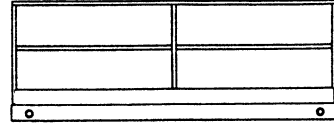

FIGURE & ITEM NO	PART NUMBER	DESCRIPTION	QTY.	REV.
13-4-2		<b>OPTIONAL PLATFORM EXTENSION INSTALLATION (CONTINUED)</b>	Ref.	
—102	4360236	Actuator, Switch	1	
—103	4360278	Roller and Arm	1	
—104	4460052	Connector, Strain Relief	1	
—105	3900168	Screw, Special	2	
—106	4920140	Lockwire	2	
—107	Not Used			
—108	3534995	Plate, Mounting	1	
—109	3931416	Bolt, Socket Head 1/4"-20NC x 1"	2	
—110	3311401	Nut 1/4"-20NC	2	
—111	4761400	Lockwasher 1/4"	2	
—112	3520072	Plug, Cap	1	
—113	1060341	Cable, Electrical - 16/2	A/R	
—114	3300047	Locknut, Conduit	1	
—115	0960239	Bushing	1	
	0251705	<b>PLATFORM EXTENSION LIMIT SWITCH INSTALLATION (ALL FRENCH SPECS AND ITALIAN SPECS PRIOR TO AUGUST 1993) (VARIABLE PARTS REQUIRED WITH STEEL CONSOLE BOX)</b>	Ref.	B
—151	4460049	Connector, Strain Relief	1	
	0253616/0254367	<b>PLATFORM EXTENSION LIMIT SWITCH INSTALLATION (ALL FRENCH SPECS AND ITALIAN SPECTS PRIOR TO AUGUST 1993) (VARIABLE PARTS REQUIRED WITH REQUIRED WITH MOLDED CONSOLE BOX)</b>	Ref.	B/—
	0254319/0254368	<b>PLATFORM EXTENSION LIMIT SWITCH INSTALLATION (ITALIAN SPECS AUGUST 1993 TO PRESENT) (VARIABLE PARTS REQUIRED WITH MOLDED CONSOLE BOX)</b>	Ref.	A/A
—151	4460052	Connector, Strain Relief	1	

SECTION 13 - 4 PLATFORM

# SECTION 13-4 PLATFORM CM1432/CM1432 PLUS/CM1732

FIGURE 13-4-2A. OPTIONAL EXTENDABLE DECK INSTALLATION  
WITH FOLD-DOWN HANDRAILS.



SECTION 13-4 PLATFORM

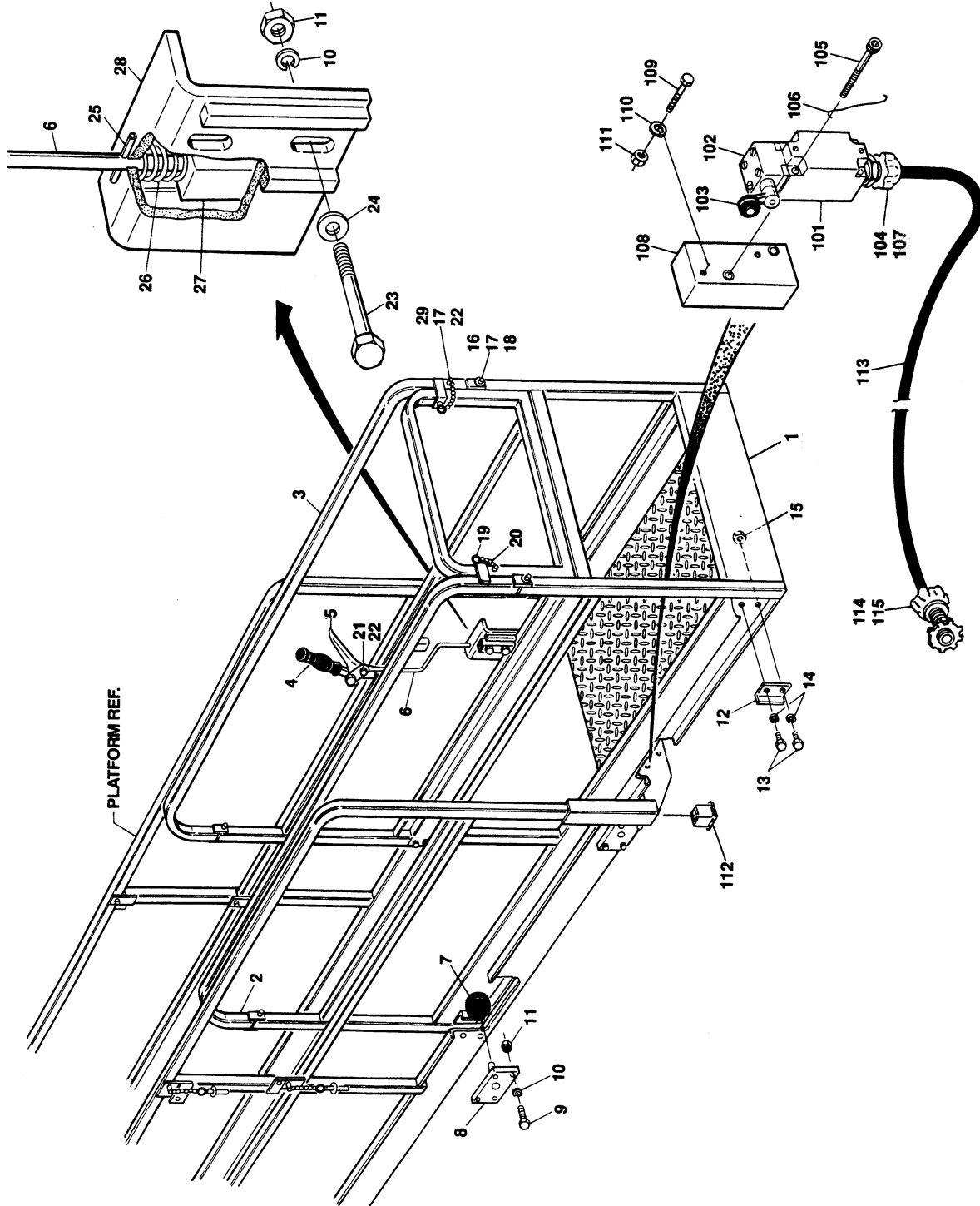

# SECTION 13-4 PLATFORM CM1432/CM1432 PLUS/CM1732

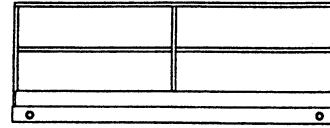

FIGURE & ITEM NO	PART NUMBER	DESCRIPTION	QTY.	REV.
13-4-2A		<b>OPTIONAL EXTENDABLE DECK INSTALLATION WITH FOLD-DOWN HANDRAILS</b>	Ref.	
	0254238	<b>EXTENDABLE DECK INSTALLATION</b>	Ref.	B
-1	3510496			
-2	3640888	Handrail - Right Side	1	
-3	3640887	Handrail - Left Side	1	
-4	2560088	Grip, Handle	1	
-5	2980113	Release Lever Assembly	1	
-6	3841130	Rod, Release (Prior to June 1995)	1	
	3841201	Rod, Release (June 1995 to Present)	1	
-7	3860052	Roller	4	
	4712200	Shim, Flatwasher (Steel)	A/R	
	4740066	Shim, Flatwasher (Thin Bronze)	A/R	
-8	4843706	Mounting Weldment - Roller	4	
-9	0641510	Bolt 5/16"-18NC x 1 1/4"	16	
-10	4761500	Lockwasher 5/16"	18	
-11	3311501	Nut 5/16"-18NC	18	
-12	0181484	Angle (Prior to June 1995)	4	
	0181684	Angle (June 1995 to Present)	4	
-13	0641406	Bolt 1/4"-20NC x 3/4"	8	
-14	4761400	Lockwasher 1/4"	12	
-15	3311401	Nut 1/4"-20NC	8	
-16	3430416	Pin, Clevis 1/4" x 2"	4	
-17	4711400	Flatwasher 1/4" Narrow	12	
-18	3450203	Pin, Cotter 1/16" x 3/4"	4	
-19	3421913	Pin, Quick Release	2	
-20	1260017	Chain (2 Lengths 7 in./17.8 Each)	14 in./35.6cm	
-21	0641406	Bolt 1/4"-20NC x 3/4"	1	
-22	3311405	Locknut 1/4"-20NC	3	
-23	0641516	Bolt 5/16"-18NC x 2"	2	
-24	4751500	Flatwasher 5/16"	4	
-25	3440413	Rollpin 1/8" x 13/16"	2	
-26	4160078	Spring	1	
-27	0361912	Bar, Latch	1	
-28	2940061	Latch Weldment	1	
-29	0641416	Bolt 1/4"-20NC x 2"	2	
		<b>PLATFORM EXTENSION LIMIT SWITCH INSTALLATION (FRENCH AND ITALIAN SPECS)</b>	Ref.	
-101	4360277	Switch, Limit	1	
-102	4360236	Actuator, Switch	1	
-103	4360278	Roller and Arm	1	
-104	4460052	Connector, Strain Relief	2	

SECTION 13 - 4 PLATFORM



# SECTION 13-4 PLATFORM CM1432/CM1432 PLUS/CM1732

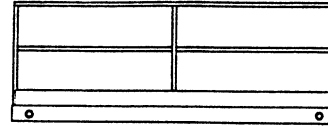
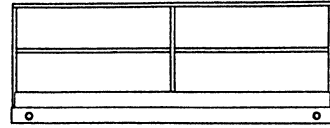

FIGURE & ITEM NO	PART NUMBER	DESCRIPTION	QTY.	REV.
13-4-2A		<b>OPTIONAL EXTENDABLE DECK INSTALLATION WITH FOLD-DOWN HANDRAILS (CONTINUED)</b>	Ref.	
—105	3900168	Screw, Special	2	
—106	4920140	Lockwire	2	
—107	4460052	Connector, Strain Relief	1	
—108	3534995	Plate, Mounting	1	
—109	3931416	Bolt, Socket head 1/4"-20NC x 1"	2	
—110	3311401	Nut 1/4"-20NC	2	
—111	4761400	Lockwasher 1/4"	2	
—112	3520072	Plug, Cap	1	
—113	1060341	Cable, Electrical - 16/2	A/R	
—114	3300047	Locknut, Conduit	1	
—115	0960239	Bushing	1	
	0253616/0254367	<b>PLATFORM EXTENSION LIMIT SWITCH INSTALLATION (ALL FRENCH SPECS AND ITALIAN SPECS PRIOR TO AUGUST 1993) (VARIABLE PARTS REQUIRED WITH MOLDED CONSOLE BOX)</b>	Ref.	B/—
	0254319/0254368	<b>PLATFORM EXTENSION LIMIT SWITCH INSTALLATION (ITALIAN SPECS AUGUST 1993 TO PRESENT) (VARIABLE PARTS REQUIRED WITH MOLDED CONSOLE BOX)</b>	Ref.	A/A
—151	4460052	Connector, Strain Relief	1	

SECTION 13 - 4 PLATFORM

# SECTION 13-4 PLATFORM CM1432/CM1432 PLUS/CM1732

FIGURE 13-4-3. STEEL PLATFORM CONSOLE BOX ASSEMBLY.



SECTION 13-4 PLATFORM

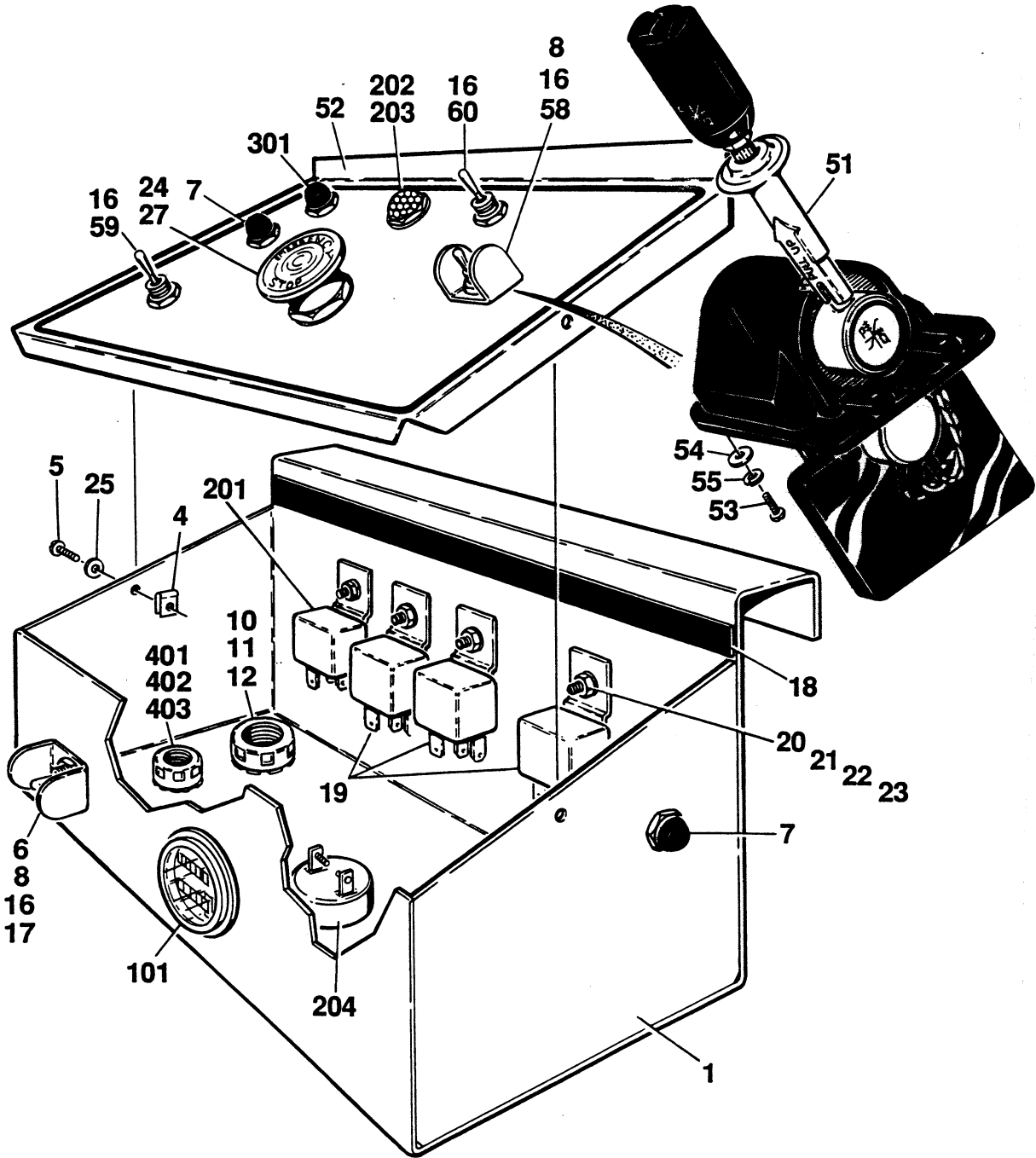



# SECTION 13-4 PLATFORM CM1432/CM1432 PLUS/CM1732

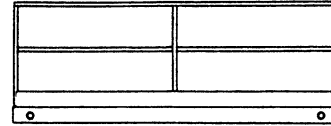

FIGURE & ITEM NO	PART NUMBER	DESCRIPTION	QTY.	REV.
13-4-3		<b>STEEL PLATFORM CONSOLE BOX ASSEMBLY</b>	Ref.	
		<b>CONSOLE BOX ASSEMBLY (STANDARD PARTS)</b>	Ref.	
-1	3534838	Box	1	
-2	Not Used			
-3	Not Used			
-4	3300177	Nut, Tinnerman	2	
-5	0751006	Screw, Machine #10 x 3/4"	2	
-6	4360202	Switch, Toggle - DPDT/MC/CO (Lift)	1	
-7	4360274	Switch, Push Button - SPST (Posi Trac)	1	
-8	4060229	Shield, Switch	A/R	
-9	Not Used			
-10	4460051	Connector, Strain Relief	1	
-11	3300048	Locknut, Conduit	1	
-12	0960238	Bushing	1	
-13	Not Used			
-14	Not Used			
-15	Not Used			
-16	3790012	O-Ring	A/R	
-17	1701453	Nametag - Lift	1	
-18	4420008	Tape, Insulation	32 in./8m	
-19	3740069	Relay, Power	A/R	
-20	3910608	Screw, Machine #6 x 1/2"	A/R	
-21	4760600	Lockwasher #6	A/R	
-22	4750600	Flatwasher #6	A/R	
-23	3310601	Nut #6-32NC	2	
-24	4360289	Switch, Push-Pull (Emergency Stop)	1	
-25	4740120	Washer, Nylon	2	
-26	Not Used			
-27	0100035	Loctite #222	A/R	
	0251671	<b>CONSOLE BOX ASSEMBLY (WITH TOGGLE SWITCH DRIVE - STANDARD) (VARIABLE PARTS)</b>	Ref.	G
-51	Not Required			
-52	3252090	Lid, Control Box	1	
-53	Not Required			
-54	Not Required			
-55	Not Required			
-56	Not Used			
-57	Not Used			
-58	4360202	Switch, Toggle - DPDT/MC/CO (Drive)	1	
-59	4360198	Switch, Toggle - SPDT/MC/CO (Steer)	1	
-60	4360092	Switch, Toggle - (Drive Speed)	1	

SECTION 13 - 4 PLATFORM



# SECTION 13-4 PLATFORM CM1432/CM1432 PLUS/CM1732

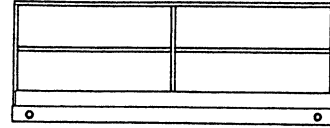
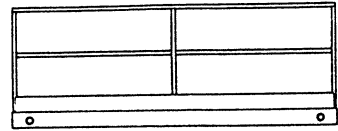

FIGURE & ITEM NO	PART NUMBER	DESCRIPTION	QTY.	REV.
13-4-3		<b>STEEL PLATFORM CONSOLE BOX ASSEMBLY (CONTINUED)</b>	Ref.	
	0251670	<b>CONSOLE BOX ASSEMBLY (WITH PQ CONTROLLER/ BANG-BANG DRIVE - STANDARD) (VARIABLE PARTS)</b>	Ref.	G
—51	1600132	Controller, PQ	1	
—52	3252089	Lid, Control Box	1	
—53	0720803	Screw, Machine #8 x 3/8"	4	
—54	4750800	Flatwasher #8	4	
—55	4760800	Lockwasher #8	4	
—56	Not Used			
—57	Not Used			
—58	Not Required			
—59	Not Required			
—60	Not Required			
	0251758	<b>OPTIONAL BATTERY/HOUR GAUGE INSTALLATION</b>	Ref.	B
—101	2420106	Gauge, Battery/Hour	1	
		<b>TILT INDICATOR INSTALLATION</b>	Ref.	
—201	3740069	Relay, Power	1	
—202	2920026	Light, Indicator - Red	1	
—203	2920094	Bulb, Light	1	
—204	0140011	Alarm, Sonalert	1	
	0251788	<b>OPTIONAL HORN INSTALLATION</b>	Ref.	B
—301	4360274	Switch, Push Button	1	
		<b>OPTIONAL BEACON LIGHT INSTALLATION</b>	Ref.	
—401	4460049	Connector, Strain Relief	1	
—402	0960239	Bushing	1	
—403	3300047	Locknut, Conduit	1	

SECTION 13-4 PLATFORM

# SECTION 13-4 PLATFORM CM1432/CM1432 PLUS/CM1732

FIGURE 13-4-4. MOLDED PLATFORM CONSOLE BOX ASSEMBLY.



SECTION 13 - 4 PLATFORM

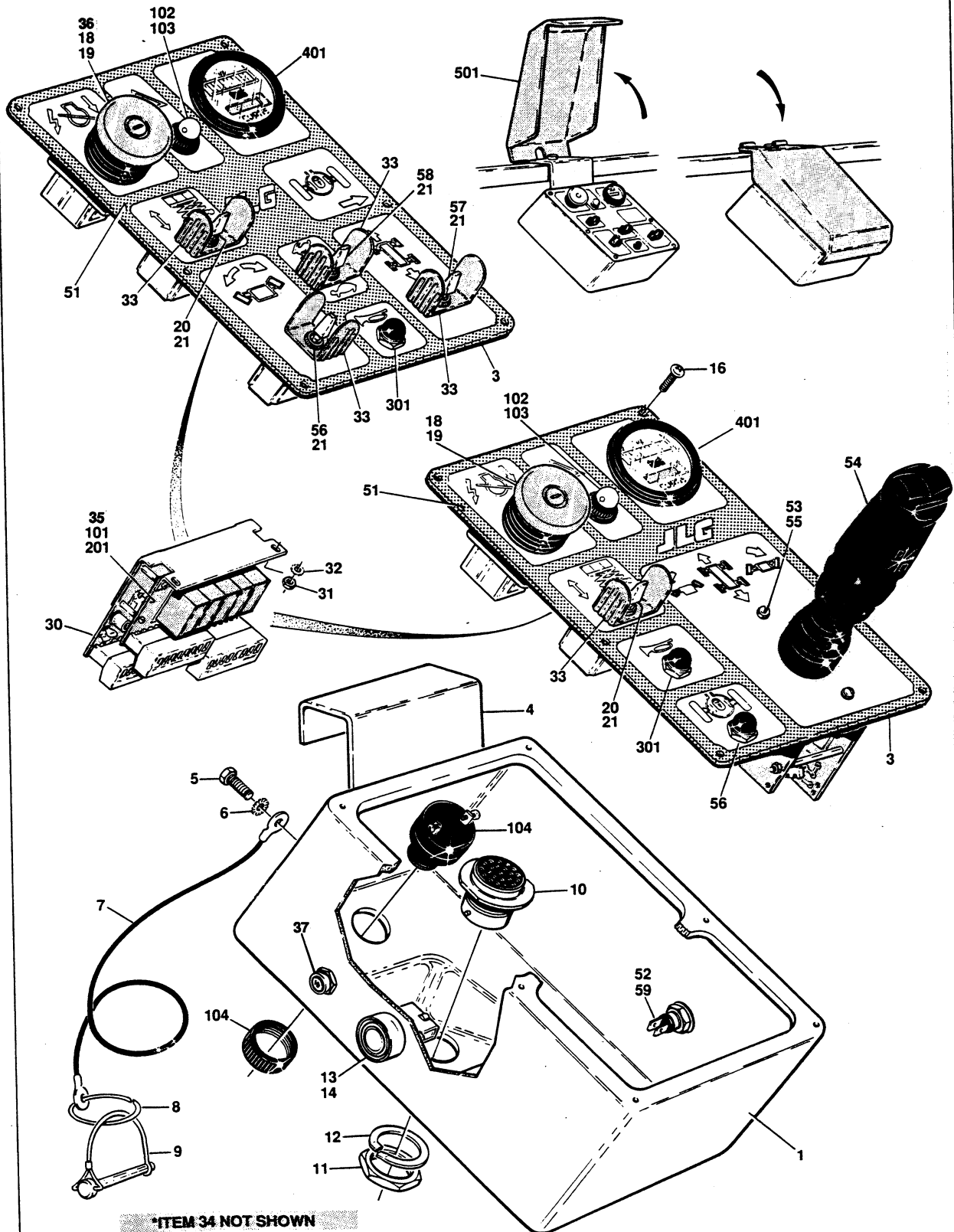

\*ITEM 34 NOT SHOWN

# SECTION 13-4 PLATFORM CM1432/CM1432 PLUS/CM1732

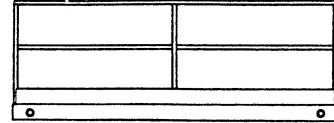
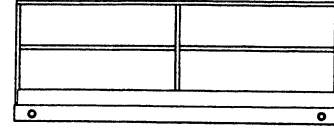

FIGURE & ITEM NO	PART NUMBER	DESCRIPTION	QTY.	REV.
13-4-4		<b>MOLDED PLATFORM CONSOLE BOX ASSEMBLY</b>	Ref.	
		<b>CONSOLE BOX ASSEMBLY (STANDARD PARTS)</b>	Ref.	
-1	0860784	Box, Console	1	
-2	Not Used			
-3	4420008	Tape, Insulation	32 in./8m	
-4	0901859	Bracket, Hanger	1	
-5	0641404	Bolt 1/4"-20NC x 1/2"	4	
-6	4791400	Starwasher 1/4"	4	
-7	1060380	Lanyard - 10"/25.4cm	1	
-9	3421453	Pin, Snapper	1	
-10	4460463	Receptacle, Terminal	1	
-11	4460470	Nut, Panel	1	
-12	4460471	Lockwasher	1	
-13	4360339	Switch, Push Button	1	
	7012593	Boot, Green Rubber	1	
-14	4360267	Switch, Contact - N.O.	1	
-15	Not Used			
-16	3900177	Screw	6	
-17	Not Used			
-18	4360289	Switch, Push/Pull (Emergency Stop)	1	
	7012611	Lens	1	
	7012612	Boot	1	
-19	0100035	Loctite #222	A/R	
-20	4360318	Switch, Toggle - DPDT/MC	1	
-21	3790012	O-Ring	A/R	
-22	Not Used			
-23	Not Used			
-24	Not Used			
-25	Not Used			
-26	Not Used			
-27	Not Used			
-28	Not Used			
-29	Not Used			
-30	0610101	Card, Circuit (RAM) (Prior to January 1995)	1	
	0610113	Card, Circuit (Jenesco) (January 1995 to Present)	1	
	0610110	Bracket, Replacement	1	
	7012658	Fuse - 7.5 Amp	1	
-31	3310601	Nut #6-32NC	2	
-32	4770600	Starwasher #6	A/R	
-33	4060802	Shield, Switch	1	
-34	1701827	Decal - Legend	1	
-35	0610105	Card, Circuit - Relay	1	
	0610110	Bracket, Mounting	1	
-36	4740066	Washer, Thrust	2	
-37	4360112	Breaker, Circuit (October 1993 to Present)	1	
	0253099	<b>CONSOLE BOX ASSEMBLY (WITH TOGGLE SWITCH DRIVE - STANDARD EURO SPEC) (VARIABLE PARTS)</b>	Ref.	H
	0253398	<b>CONSOLE BOX ASSEMBLY (WITH TOGGLE SWITCH DRIVE - AUSTRALIAN/FRENCH SPEC) (VARIABLE PARTS)</b>	Ref.	G
-51	3252196	Lid, Control Box (Prior to January 1993)	1	
	3252253	Lid, Control Box (January 1993 to Present)	1	

SECTION 13 - 4 PLATFORM

# SECTION 13-4 PLATFORM CM1432/CM1432 PLUS/CM1732



SECTION 13 - 4 PLATFORM

FIGURE & ITEM NO	PART NUMBER	DESCRIPTION	QTY.	REV.
13-4-4		<b>MOLDED PLATFORM CONSOLE BOX ASSEMBLY (CONTINUED)</b>	Ref.	
-52	4360274	Switch, Push Button - SPST (Posi Trac)	1	
-53	Not Required			
-54	Not Required			
-55	Not Required			
-56	4360328	Switch, Toggle - SPST/MC/CO (Steer)	1	
-57	4360314	Switch, Toggle - DPDT/MC/CO (Drive)	1	
-58	4360345	Switch, Toggle - SPDT (Drive Speed)(2SPD - Prior to January 1993)	1	
	4360355	Switch, Toggle - DPDT (Drive Speed) (3SPD - January 1993 to Present)	1	
-59	Not Required			
	0253101	<b>CONSOLE BOX ASSEMBLY (WITH PQ CONTROLLER/ BANG-BANG DRIVE - STANDARD EURO SPEC) (VARIABLE PARTS)</b>	Ref.	G
	0253401	<b>CONSOLE BOX ASSEMBLY (WITH PQ CONTROLLER/ BANG-BANG DRIVE - FRENCH SPEC) (VARIABLE PARTS)</b>	Ref.	E
-51	3252194	Lid, Control Box	1	
-52	3520026	Plug, Hole	1	
-53	4740120	Washer, Nylon	2	
-54	1600156	Controller, PQ	1	
-55	3900178	Screw, Machine #10-32NF x 3/4"	2	
-56	4360274	Switch, Push Button - SPST (Posi-Trac)	1	
-57	Not Required			
-58	Not Required			
-59	0100009	Sealant, Silicon	A/R	
	0253405	<b>CONSOLE BOX ASSEMBLY (WITH PQ CONTROLLER/ PROPORTIONAL DRIVE - STANDARD EURO SPEC) (VARIABLE PARTS)</b>	Ref.	E
	0253406	<b>CONSOLE BOX ASSEMBLY (WITH PQ CONTROLLER/ PROPORTIONAL DRIVE - FRENCH SPEC) (VARIABLE PARTS)</b>	Ref.	E
-51	3252194	Lid, Control Box	1	
-52	3520026	Plug, Hole	1	
-53	4740120	Washer, Nylon	2	
-54	1600160	Controller, PQ	1	
-55	3900178	Screw, Machine #10-32NF x 3/4"	2	
-56	4360274	Switch, Push Button - SPST (Posi-Trac)	1	
-57	Not Required			
-58	Not Required			
-59	0100009	Sealant, Silicon	A/R	

# SECTION 13-4 PLATFORM CM1432/CM1432 PLUS/CM1732

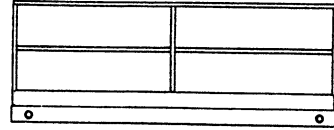

FIGURE & ITEM NO	PART NUMBER	DESCRIPTION	QTY.	REV.
13-4-4		<b>MOLDED PLATFORM CONSOLE BOX ASSEMBLY (CONTINUED)</b>	Ref.	
	0253485	<b>TILT INDICATOR INSTALLATION</b>	Ref.	B
—101	0610105	Card, Circuit - Relay	1	
	0610110	Bracket, Mounting	1	
—102	2920094	Bulb, Light	1	
—103	2920026	Light, Indicator - Red	1	
—104	0140011	Alarm, Sonalert	1	
	0253491	<b>DRIVE CUT-OUT INSTALLATION</b>	Ref.	A
—201	0610105	Card, Circuit - Relay	1	
	0610110	Bracket, Mounting	1	
	0253465	<b>OPTIONAL HORN INSTALLATION</b>	Ref.	—
—301	4360274	Switch, Push Button	1	
	4921537	Harness, Switch	1	
	0253499	<b>OPTIONAL BATTERY/HOUR GAUGE INSTALLATION</b>	Ref.	A
—401	2420106	Gauge, Battery/Hour	1	
	0253548	<b>OPTIONAL CONSOLE BOX INSTALLATION</b>	Ref.	—
—501	4844327	Cover	1	

SECTION 13 - 4 PLATFORM





# SECTION 13-5 CYLINDERS CM1432/CM1432 PLUS/CM1732

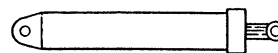

## TABLE OF CONTENTS

FIGURE NO.	TITLE	PAGE NO.
13-5-1	Brake Cylinder Assembly .....	13-5-2
13-5-2	Lift Cylinder Sub-Assembly .....	13-5-4
13-5-3	Steer Cylinder Assembly .....	13-5-8

SECTION 13-5 CYLINDERS

# SECTION 13-5 CYLINDERS CM1432/CM1432 PLUS/CM1732

FIGURE 13-5-1. BRAKE CYLINDER ASSEMBLY.

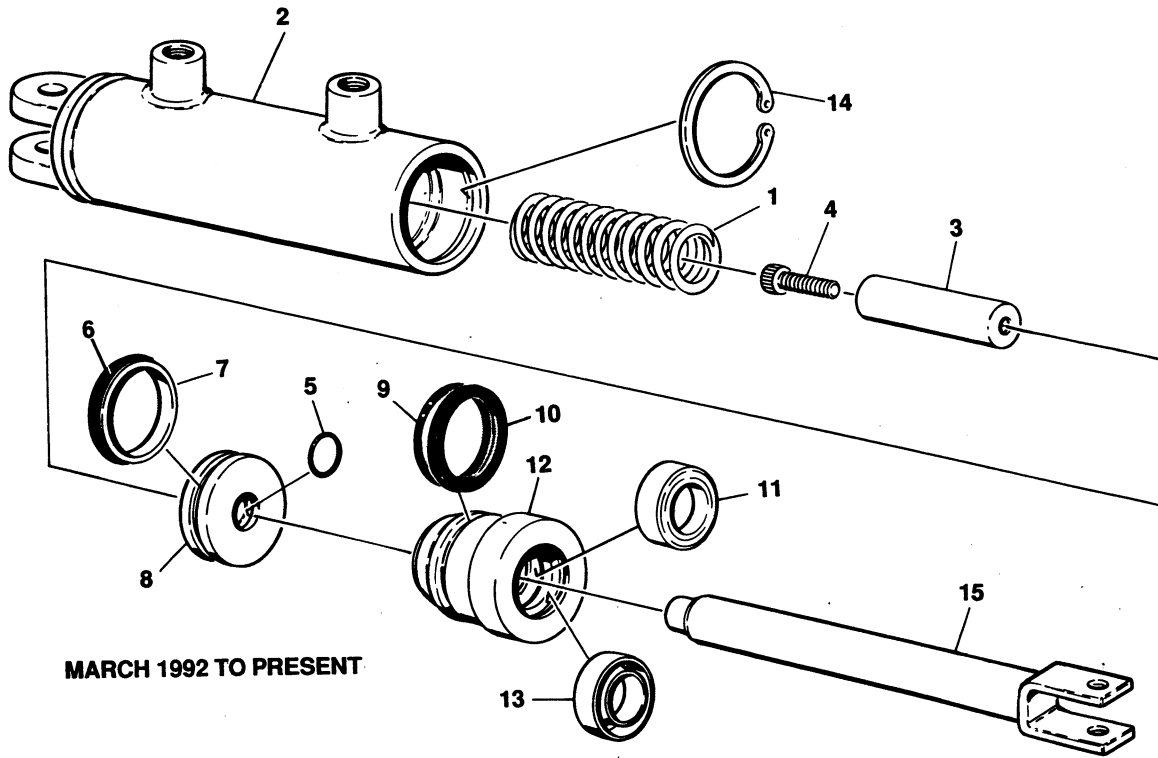
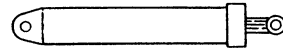

MARCH 1992 TO PRESENT

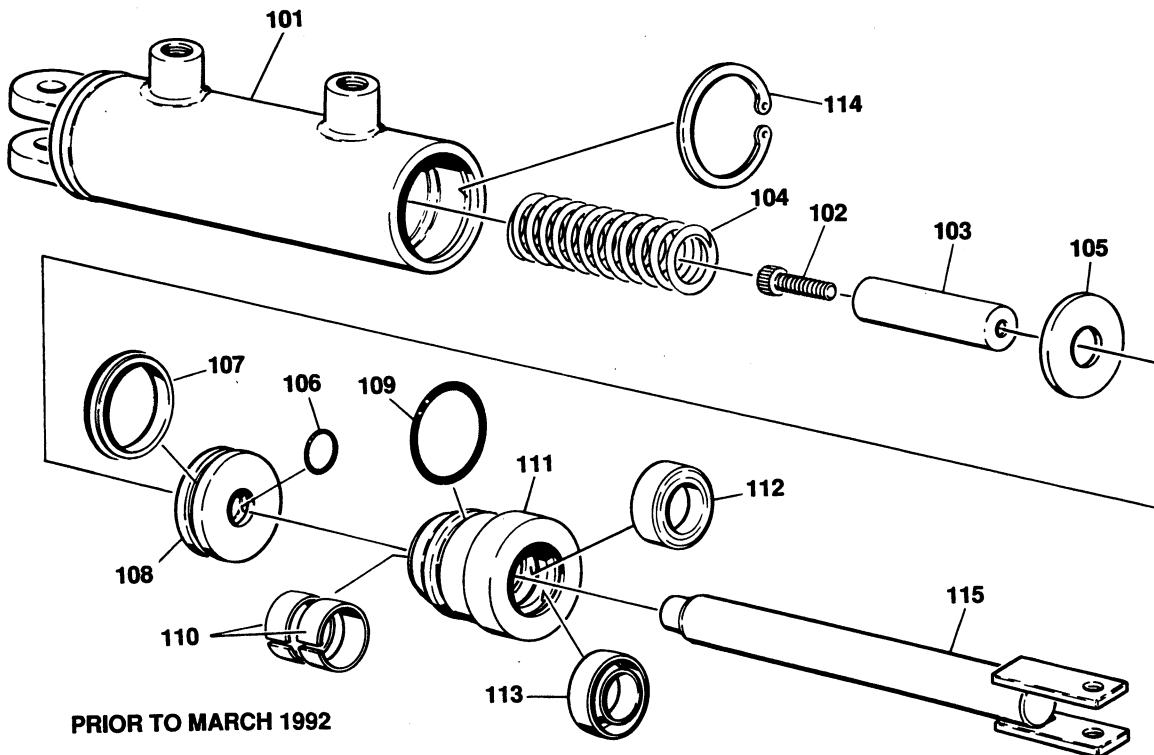

PRIOR TO MARCH 1992

SECTION 13-5 CYLINDERS

# SECTION 13-5 CYLINDERS CM1432/CM1432 PLUS/CM1732

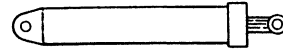
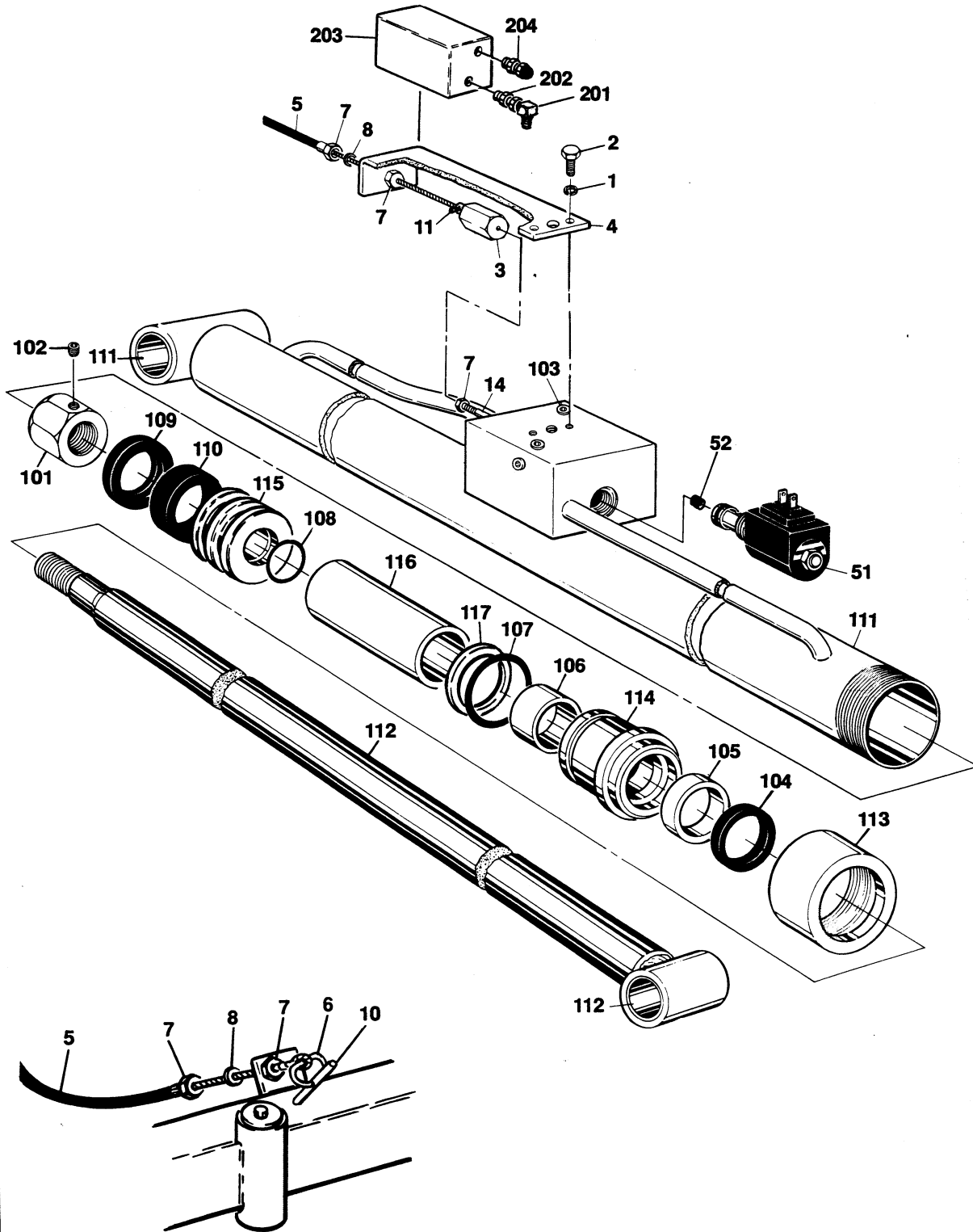
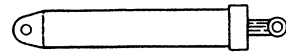

FIGURE & ITEM NO	PART NUMBER	DESCRIPTION	QTY.	REV.
13-5-1	1682277	<b>BRAKE CYLINDER ASSEMBLY (MARCH 1992 TO DECEMBER 1993)</b> <b>Note: When replacing complete 1682277 cylinder recommend using 1683098 cylinder.</b>	Ref.	—
	1683098	<b>BRAKE CYLINDER ASSEMBLY (DECEMBER 1993 TO PRESENT)</b>	Ref.	
—1	7001093	Spring, Compression (1682277 Cylinder)	1	
	7001618	Spring, Compression (1683098 Cylinder)	1	
—2	Not Available	Barrel, Cylinder	1	
—3	7001094	Spacer (1682277 Cylinder)	1	
	7001620	Spacer (1683098 Cylinder)	1	
—4	7001095	Bolt, Socket Head	1	
—5	Kit	O-Ring	1	
—6	Kit	Ring, Piston	1	
—7	Kit	O-Ring	1	
—8	7001096	Piston	1	
—9	Kit	O-Ring	1	
—10	Kit	Ring, Back-up	1	
—11	Kit	Seal	1	
—12	7001097	Head	1	
—13	Kit	Ring, Wiper	1	
—14	7001098	Ring, Retaining	1	
—15	7001099	Rod Weldment (1682277 Cylinder)	1	
	7001621	Rod Weldment (1683098 Cylinder)	1	
	7001092	Seal Kit (Includes Items 5,6,7,9,10,11 and 13)	1	
	1682277	<b>BRAKE CYLINDER ASSEMBLY (PRIOR TO MARCH 1992)</b> <b>Note: When replacing complete 1682277 cylinder recommend using 1683098 cylinder.</b>	Ref.	—
—101	1682278	Barrel Weldment	1	
—102	3931512	Bolt, Socket Head 5/16"-18NC x 3/4"	1	
	0100011	Loctite #242	A/R	
	0100038	Primer, Loctite	A/R	
—103	0361905	Bar, Stop	1	
—104	4160100	Spring, Compression	1	
—105	4740215	Washer, Special	1	
—106	Kit	O-Ring	1	
—107	Kit	T-Seal	1	
—108	3480145	Piston	1	
—109	Kit	O-Ring	1	
—110	Kit	Ring, Wear	2	
—111	1682276	Head	1	
—112	Kit	Seal, Rod	1	
—113	Kit	Wiper, Rod	1	
—114	3760278	Ring, Retainer	1	
—115	1682515	Rod Weldment	1	
	2901160	Seal Kit (Includes Items 106, 107, 109, 110, 112 and 113)	1	

SECTION 13-5 CYLINDERS

# SECTION 13-5 CYLINDERS CM1432/CM1432 PLUS/CM1732

FIGURE 13-5-2. LIFT CYLINDER SUB-ASSEMBLY.



SECTION 13-5 CYLINDERS

# SECTION 13-5 CYLINDERS CM1432/CM1432 PLUS/CM1732

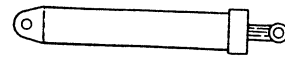

SECTION 13 - 5 CYLINDERS

FIGURE & ITEM NO	PART NUMBER	DESCRIPTION	QTY.	REV.
13-5-2		<b>LIFT CYLINDER SUB-ASSEMBLY</b>	Ref.	
	0252673	<b>VALVES AND CONTROLS INSTALLATION - CM1432 (STANDARD PARTS)</b>	Ref.	D
	0253905	<b>VALVES AND CONTROLS INSTALLATION - CM1432 PLUS (STANDARD PARTS)</b>	Ref.	B
	0253907	<b>VALVES AND CONTROLS INSTALLATION - CM1732 (STANDARD PARTS)</b>	Ref.	A
-1	4761500	Lockwasher 5/16"	2	
-2	0641506	Bolt 5/16"-18NC x 3/4"	2	
-3	0080190	Adapter	1	
-4	0901757	Bracket, Cable	1	
-5	1060403	Cable Assembly	1	
-6	3760170	D-Ring	1	
-7	3311402	Nut, Jam 1/4"-20NC	5	
-8	4751400	Flatwasher 1/4"	2	
-9	Not Used			
-10	3841127	Rod, Handle	1	
-11	3450405	Pin, Cotter	1	
-12	Not Used			
-13	Not Used			
-14	4640717	Cartridge, Valve - Manual Pull Control	1	
		<b>VALVES AND CONTROLS INSTALLATION - STANDARD MACHINES (VARIABLE PARTS)</b>	Ref.	
-51	4640381	Cartridge, Valve - Solenoid Holding	1	
	7004334	Coil - 24VDC (Modular Controls Version)	1	
	7000644	Coil - 24VDC (Hydraforce Version)	1	
	2900503	Seal Kit (Modular Controls Version)	1	
	2900756	Seal Kit (Hydraforce Version)	1	
-52	2220894	Fitting, Orifice (CM1432 Only) (Not Required on CM1432 Plus and CM1732)	1	
	1682505	<b>LIFT CYLINDER ASSEMBLY - CM1432 (STANDARD PARTS)</b>	Ref.	B
-101	3300281	Nut, Hex	1	
-102	3900170	Setscrew 3/8"-16NC x 3/8"	1	
-103	2200221	Plug, Pipe	5	
-104	Kit	Seal, Wiper	1	
-105	Kit	Seal, Rod	1	
-106	Kit	Ring, Wear	1	
-107	Kit	O-Ring	1	
-108	Kit	O-Ring	1	
-109	Kit	T-Seal	1	
-110	Kit	Ring, Wear	1	
-111	1682506	Barrel Weldment	1	
	0961616	Bushing, Bronze	1	
-112	1682508	Rod Weldment	1	
	0961616	Bushing, Bronze	1	
-113	1120119	Cap, End	1	
-114	1682510	Head	1	
-115	3480120	Piston	1	
-116	4565208	Tube, Spacer	1	



# SECTION 13-5 CYLINDERS CM1432/CM1432 PLUS/CM1732

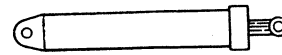

FIGURE & ITEM NO	PART NUMBER	DESCRIPTION	QTY.	REV.
13-5-2		<b>LIFT CYLINDER SUB-ASSEMBLY (CONTINUED)</b>	Ref.	
—117	Kit	Ring, Back-Up	1	
	0100011	Loctite #242	A/R	
	0100020	Sealant, Pipe	A/R	
	0100035	Loctite #222	A/R	
	0100038	Primer, Locking	A/R	
	2901192	Seal Kit (Includes Items 104-110 and 117)	1	
	1682907	<b>LIFT CYLINDER ASSEMBLY - CM1432 PLUS AND CM1732 (STANDARD PARTS)</b>	Ref.	B
—101	3300281	Nut, Hex	1	
—102	3900170	Setscrew 3/8"-16NC x 3/8"	1	
—103	2200221	Plug, Pipe	4	
—104	Kit	Seal, Wiper	1	
—105	Kit	Seal, Rod	1	
—106	Kit	Ring, Wear	1	
—107	Kit	O-Ring	1	
—108	Kit	O-Ring	1	
—109	Kit	Ring, Lock	1	
—110	Kit	Seal	1	
—111	1682908	Barrel Weldment	1	
	0961616	Bushing, Bronze	1	
—112	1682909	Rod Weldment	1	
	0961616	Bushing, Bronze	1	
—113	1120108	Cap, End	1	
—114	1681283	Head	1	
—115	3480147	Piston	1	
—116	4564885	Tube, Spacer	1	
—117	Not Required			
	0100011	Loctite #242	A/R	
	0100020	Sealant, Pipe	A/R	
	0100035	Loctite #222	A/R	
	0100038	Primer, Locking	A/R	
	2901165	Seal Kit (Includes Items 104-110)	1	
	0253090	<b>OVERLOAD PROTECTION INSTALLATION (FRENCH SPEC ONLY)</b>	Ref.	A
—201	2220879	Fitting, 90°	1	
—202	2220440	Fitting, Straight	1	
—203	1692617	Switch, Pressure	1	
—204	4460428	Connector, Strain Relief	1	

SECTION 13 - 5 CYLINDER

# SECTION 13-5 CYLINDERS CM1432/CM1432 PLUS/CM1732

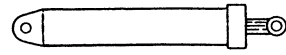
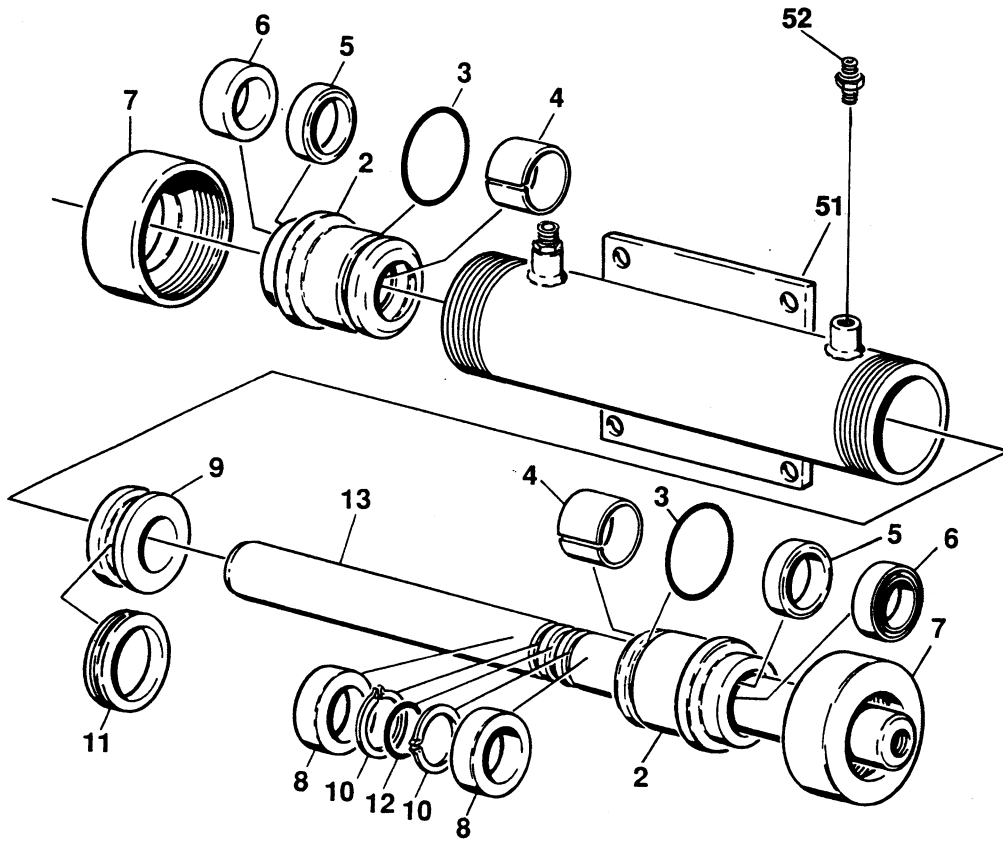

FIGURE 13-5-3. STEER CYLINDER ASSEMBLY.

SECTION 13-5 CYLINDERS





# SECTION 13-5 CYLINDERS CM1432/CM1432 PLUS/CM1732

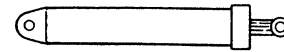

FIGURE & ITEM NO	PART NUMBER	DESCRIPTION	QTY.	REV.
13-5-3	1682379	<b>STEER CYLINDER ASSEMBLY</b>	Ref.	B
—1	Not Used			
—2	1682364	Head	2	
—3	Kit	O-Ring	2	
—4	Kit	Ring, Wear	2	
—5	Kit	Seal, Rod	2	
—6	Kit	Wiper	2	
—7	1120387	Retainer	2	
	0100035	Loctite	A/R	
—8	4564976	Spacer, Tube	2	
—9	3480153	Piston	1	
—10	3760141	Ring, Retaining	2	
—11	Kit	T-Seal	1	
—12	Kit	O-Ring	1	
—13	1682382	Rod	1	
	2901178	Seal Kit (Includes Items 3,4,5,6,11 and 12)	1	
	1682379	<b>STEER CYLINDER ASSEMBLY - MACHINES BUILT PRIOR TO JULY 1993 (VARIABLE PARTS)</b>	Ref.	A
—51	1682380	Barrel	1	
—52	2220414	Fitting, Straight	2	
	1682996	<b>STEER CYLINDER ASSEMBLY - MACHINES BUILT JULY 1993 TO SEPTEMBER 1995</b>	Ref.	—
—51	1682994	Barrel	1	
—52	2180803	Fitting	2	
	2180804	Orifice (.040) (July 1993 to June 1995)	2	
	2180804	Orifice (.040) (June 1995 to September 1995)	2	
	1683408	<b>STEER CYLINDER ASSEMBLY - MACHINES BUILT SEPTEMBER 1995 TO PRESENT (VARIABLE PARTS)</b>	Ref.	A
—51	1682994	Barrel	1	
—52	2180803	Fitting	2	
	2180804	Orifice (.040)	2	

**SECTION 13-5 CYLINDERS**



**SECTION 13-6 HYDRAULICS  
CM1432/CM1432 PLUS/CM1732**



**TABLE OF CONTENTS**

FIGURE NO.	TITLE	PAGE NO.
13-6-1	Hydraulic Diagram - Standard .....	13-6-2

**S  
E  
C  
T  
I  
O  
N  
  
1  
3  
-  
6  
  
H  
Y  
D  
R  
A  
U  
L  
I  
C  
S**

# SECTION 13-6 HYDRAULICS CM1432/CM1432 PLUS/CM1732

FIGURE 13-6-1. HYDRAULIC DIAGRAM - STANDARD.



\*\*\*NOTES\*\*\*  
\*X\* DEMOTES A NON-STRAIGHT HOSE END

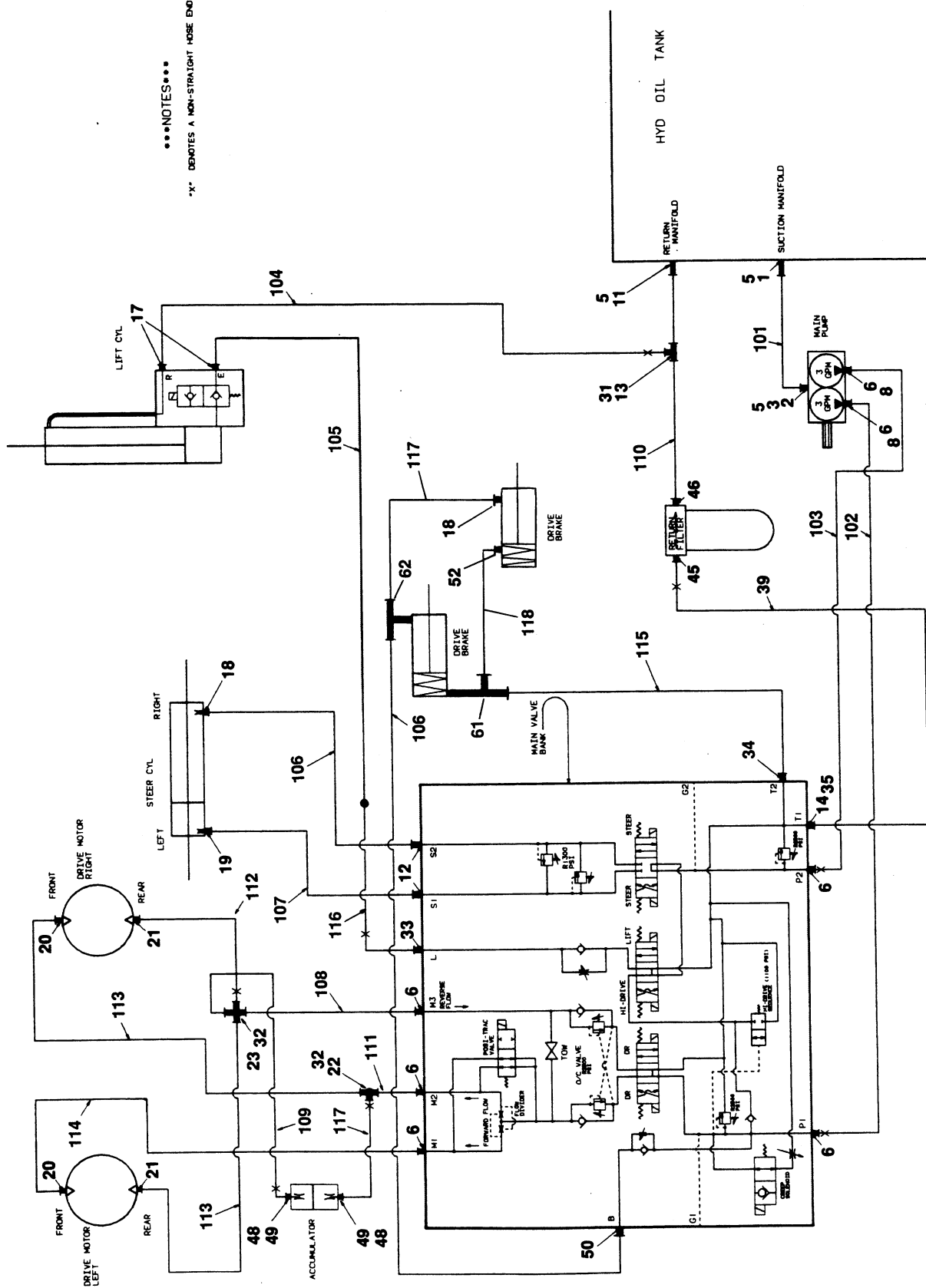

SECTION 13-6 HYDRAULICS

# SECTION 13-6 HYDRAULICS CM1432/CM1432 PLUS/CM1732



FIGURE & ITEM NO	PART NUMBER	DESCRIPTION	QTY.	REV.
13-6-1	2791927	HYDRAULIC DIAGRAM - STANDARD	Ref.	D
-1	4565540	Tube	1	
-2	2210008	Fitting, 90°	1	
-3	2220593	Fitting, Straight	1	
-4	Not Used			
-5	1320030	Clamp	6	
-6	2220600	Fitting, Straight	7	
-7	Not Used			
-8	2220386	Fitting, 90°	2	
-9	Not Used			
-10	Not Used			
-11	4565541	Tube, Return	1	
-12	2220415	Fitting, Straight	2	
-13	2220620	Fitting, Reducer	1	
-14	2220471	Fitting, 90°	1	
-15	Not Used			
-16	Not Used			
-17	2220343	Fitting, Straight	2	
-18	2220416	Fitting, 90°	3	
-19	2220414	Fitting, Straight	1	
-20	2220850	Fitting, 90°	2	
-21	2220851	Fitting, 90°	2	
-22	2220362	Fitting, Tee	1	
-23	2220469	Fitting, Union	1	
-24 to -30	Not Used			
-31	2220849	Fitting, Tee	1	
-32	2220618	Fitting, Reducer	2	
-33	2220371	Fitting, Straight	1	
-34	2220603	Fitting, Straight	1	
-35	2220373	Fitting, Straight	1	
-36 to -44	Not Used			
-45	2220470	Fitting, 40°	1	
-46	2220346	Fitting, Straight	1	
-47	Not Used			
-48	2180699	Fitting	2	
-49	2180422	Fitting, Modified	2	
-50	2220587	Fitting, Straight	1	
-51	Not Used	Hose	1	
-52	2220773	Fitting, 90°	1	
-53 to -60	Not Used			
-61	2220702	Fitting, Tee	1	
-62	2220584	Fitting, Tee	1	
	2901281	HYDRAULIC HOSE KIT (STANDARD PARTS)	Ref.	A
-101	2720370	Hose, Suction 3/4" x 6 1/2"/16.5cm	1	
-102	2751488	Hose	1	
-103	2750968	Hose	2	

SECTION 13 - 6 HYDRAULICS

# SECTION 13-6 HYDRAULICS CM1432/CM1432 PLUS/CM1732



FIGURE & ITEM NO	PART NUMBER	DESCRIPTION	QTY.	REV.
13-6-1	2791927	HYDRAULIC DIAGRAM - STANDARD (CONTINUED)	Ref.	D
-104	2751129	Hose	1	
-105	2751128	Hose	1	
-106	2751021	Hose	2	
-107	2751396	Hose	1	
-108	2750976	Hose	1	
-109	2751412	Hose	1	
-110	2751523	Hose	1	
-111	2750929	Hose	1	
-112	2751533	Hose	1	
-113	2751534	Hose	2	
-114	2750934	Hose	1	
-115	2751005	Hose	1	
-116	2751158	Hose	1	
-117	2750902	Hose	2	
-118	2750919	Hose	1	

**SECTION 13-6 HYDRAULICS**

# SECTION 13-7 ELECTRICAL CM1432/CM1432 PLUS/CM1732



## TABLE OF CONTENTS

FIGURE NO.	DESCRIPTION	PAGE NO.
13-7-1	Electrical Diagrams and Components Chart. ....	13-7-2
13-7-2	Electrical Diagram - Toggle Switch Drive (Standard Euro Spec) .....	13-7-8
13-7-3	Electrical Diagram - Toggle Switch Drive (Australian Spec) .....	13-7-9
13-7-4	Electrical Diagram - Toggle Switch Drive (French Spec) .....	13-7-10
13-7-5	Electrical Diagram - PQ Controller Bang-Bang Drive (Standard Euro Spec) .	13-7-11
13-7-6	Electrical Diagram - PQ Controller Bang-Bang Drive (Australia Spec) .....	13-7-12
13-7-7	Electrical Diagram - PQ Controller Bang-Bang Drive (French Spec) .....	13-7-13
13-7-8	Electrical Diagram - Circuit Cards .....	13-7-15
13-7-9	Main Electrical Connector and Tools .....	13-7-16

**S  
E  
C  
T  
I  
O  
N  
  
1  
3  
-  
7  
  
E  
L  
E  
C  
T  
R  
I  
C  
A  
L**

# SECTION 13-7 ELECTRICAL CM1432/CM1432 PLUS/CM1732



**SECTION 13 - 7 ELECTRICAL**

FIGURE & ITEM NO	PART NUMBER	DESCRIPTION	QTY.	REV.
13-7-1		<b>ELECTRICAL DIAGRAMS AND COMPONENTS CHART</b>  (Note: *Indicates Diagrams shown in the following pages. Diagrams not shown are available from JLG Service Department upon request.)	Ref.	
	1281570	<b>ALARMS ELECTRICAL DIAGRAM (DWG. ONLY)</b>	Ref.	E
	0251762	<b>ALARM ELECTRICAL DIAGRAM - DESCENT (B/M ONLY)</b>	Ref.	B
	0251761	<b>ALARM ELECTRICAL DIAGRAM - MOTION (TOGGLE SWITCH DRIVE) (B/M ONLY)</b>	Ref.	B
	0254268	<b>ALARM ELECTRICAL DIAGRAM - MOTION (PQ BANG-BANG DRIVE) (B/M ONLY)</b>	Ref.	—
	0251760	<b>ALARM ELECTRICAL DIAGRAM - TRAVEL (TOGGLE SWITCH DRIVE) (B/M ONLY)</b>	Ref.	B
	0254267	<b>ALARM ELECTRICAL DIAGRAM - TRAVEL (PQ BANG-BANG DRIVE) (B/M ONLY)</b>	Ref.	—
	0140025	Alarm (Descent and Travel)	1	
	0140033	Alarm (Motion)	1	
	3990010	Diode - 6 Amp	A/R	
	0251758	<b>BATTERY/HOUR GAUGE ELECTRICAL DIAGRAM (STEEL CONSOLE BOX)</b>	Ref.	B
	0253499	<b>BATTERY/HOUR GAUGE ELECTRICAL DIAGRAM (MOLDED CONSOLE BOX)</b>	Ref.	A
	2420106	Gauge, Battery/Hour	1	
	0252274	<b>BEACON LIGHT ELECTRICAL DIAGRAM (FRAME MOUNTED)</b>	Ref.	A
	2920087	Light Beacon	1	
	1060341	Cable, Electrical - 16/2	6 ft./1.8m	
	0251870	<b>BEACON LIGHT ELECTRICAL DIAGRAM (PLATFORM MOUNTED LIGHT/STEEL CONSOLE BOX)</b>	Ref.	B
	2920092	Light Beacon	1	
	1060341	Cable, Electrical 16 ft./5m	16 ft./5m	
	4460049	Connector, Strain Relief (Located at Console Box)	1	
	3300047	Locknut, Conduit (Located at Console Box)	1	
	0960239	Bushing (Located at Console Box)	1	
	1281952	<b>BEACON LIGHT ELECTRICAL DIAGRAM (PLATFORM MOUNTED LIGHT/MOLDED CONSOLE BOX (DWG ONLY)</b>	Ref.	A
	0253474	<b>BEACON LIGHT ELECTRICAL DIAGRAM - CM1432/CM1432 PLUS (B/M ONLY)</b>	Ref.	—
	0254032	<b>BEACON LIGHT ELECTRICAL DIAGRAM - CM1732 B/M ONLY)</b>	Ref.	—
	2920087	Light, Beacon - Standard	1	
	1060341	Cable, Electrical - 16/2	A/R	



# SECTION 13-7 ELECTRICAL

## CM1432/CM1432 PLUS/CM1732



FIGURE & ITEM NO	PART NUMBER	DESCRIPTION	QTY.	REV.
13—7—1		<b>ELECTRICAL DIAGRAMS AND COMPONENTS CHART (CONTINUED)</b>	Ref.	
	0610101	<b>ELECTRICAL DIAGRAM - CIRCUIT CARD (ENABLE) (PRIOR TO JANUARY 1995)</b>	Ref.	—
	0610113*	<b>ELECTRICAL DIAGRAM - CIRCUIT CARD (ENABLE) (JANUARY 1995 TO PRESENT)</b>	Ref.	—
	0610103*	<b>ELECTRICAL DIAGRAM - CIRCUIT CARD (RELAY)</b>	Ref.	—
	0251788	<b>HORN ELECTRICAL DIAGRAM (STEEL CONSOLE BOX)</b>	Ref.	B
	0253465	<b>HORN ELECTRICAL DIAGRAM (MOLDED CONSOLE BOX)</b>	Ref.	A
	0140022	Horn	1	
	4360274	Switch, Push Button	1	
	1060341	Cable, Electrical - 16/2	8 ft./2.4m	
	0251705	<b>PLATFORM EXTENSION INTERLOCK ELECTRICAL DIAGRAM (STEEL CONSOLE BOX) (ALL FRENCH SPECS AND ITALIAN SPECS PRIOR TO AUGUST 1993)</b>	Ref.	B
	1281993	<b>PLATFORM EXTENSION INTERLOCK ELECTRICAL DIAGRAM (MOLDED CONSOLE BOX) (ALL FRENCH SPECS AND ITALIAN SPECS PRIOR TO AUGUST 1993) (DWG ONLY)</b>	Ref.	D
	0253616	<b>PLATFORM EXTENSION INTERLOCK ELECTRICAL DIAGRAM (MOLDED CONSOLE BOX) (B/M ONLY)</b>	Ref.	B
	4360277	Switch, Limit	1	
	1060341	Cable, Electrical - 16/2	A/R	
	1282149	<b>PLATFORM EXTENSION INTERLOCK ELECTRICAL DIAGRAM (MOLDED CONSOLE BOX) (ITALIAN SPECS AUGUST 1993 TO PRESENT) (DWG. ONLY)</b>	Ref.	A
	0254319	<b>PLATFORM EXTENSION INTERLOCK ELECTRICAL DIAGRAM - CM1432 (B/M ONLY)</b>	Ref.	A
	0254368	<b>PLATFORM EXTENSION INTERLOCK ELECTRICAL DIAGRAM - CM1732 (B/M ONLY)</b>	Ref.	A
	4360277	Switch, Limit	1	
	1060341	Cable, Electrical - 16/2	A/R	
	1060079	Cable, Electrical - 16/4	7 ft./2m	
	3740069	Relay	1	
	0239707	<b>PLATFORM WORKLIGHTS ELECTRICAL DIAGRAM (WITH STEEL CONSOLE BOX)</b>	Ref.	—
	1281951	<b>PLATFORM WORKLIGHTS ELECTRICAL DIAGRAM (MOLDED CONSOLE BOX) (DWG ONLY)</b>	Ref.	A
	0253502	<b>PLATFORM WORKLIGHTS ELECTRICAL DIAGRAM - CM1432/CM1432 PLUS (WITH MOLDED CONSOLE BOX) (B/M ONLY)</b>	Ref.	—
	0254038	<b>PLATFORM WORKLIGHTS ELECTRICAL DIAGRAM - CM1732 (WITH MOLDED CONSOLE BOX) (B/M ONLY)</b>	Ref.	—
	2920088	Worklight (Machines with Steel Console Box)	2	
	2920093	Worklight (Machines with Molded Console Boxes)	2	
	1060341	Cable, Electrical - 16/2 (Molded Console Box Only)	A/R	

**SECTION 13 - 7 ELECTRICAL**

# SECTION 13-7 ELECTRICAL CM1432/CM1432 PLUS/CM1732



SECTION 13 - 7 ELECTRICAL

FIGURE & ITEM NO	PART NUMBER	DESCRIPTION	QTY.	REV.
13-7-1		<b>ELECTRICAL DIAGRAMS AND COMPONENTS CHART (CONTINUED)</b>	Ref.	
		<b>STANDARD 'GROUND TO PLATFORM' CABLE/HARNESS WITH STEEL CONSOLE BOX:</b>	Ref.	
	1060039	Cable, Electrical - 16/24 (CM1432)	32 ft./9.8m	
		<b>WITH MOLDED CONSOLE BOX:</b>		
	4921513	Harness Assembly - CM1432/CM1432 Plus (Euro Spec except French)	1	
	4921514	Harness Assembly - CM1432/CM1432 Plus (French Spec)	1	
	4921588	Harness Assembly - CM1732 (Euro Spec except French)	1	
	4921589	Harness Assembly - CM1732 (French Spec)	1	
	1281559	<b>STANDARD ELECTRICAL DIAGRAM (TOGGLE SWITCH DRIVE/STEEL CONSOLE BOX) (DWG ONLY)</b>	Ref.	C
	4932424	Ground Components (B/M Only)	Ref.	—
	4932372	Platform Components (B/M Only)	Ref.	—
	4921384	Valve and Ground Control Harness	1	
	4460277	Strip, Terminal - 14 Position	1	
	4460264	Strip, Terminal	2	
	4460007	Strip, Terminal - 6 Position	2	
	3990010	Diode - 6 Amp	6	
	1060341	Cable, Electrical - 16/2 (To Lift Overload Switch/ To Level Sensor)	16 ft./4.9m	
	1281882*	<b>STANDARD ELECTRICAL DIAGRAM (TOGGLE SWITCH DRIVE/MOLDED CONSOLE BOX STANDARD EURO SPEC) (DWG ONLY)</b>	Ref.	E
	4932528	Ground Components (B/M Only)	Ref.	A
	4932527	Platform Components (B/M Only)	Ref.	A
	4921461	Valve and Ground Control Harness	1	
	4460277	Strip, Terminal - 14 Position	1	
	4460264	Strip, Terminal - 6 Position	2	
	3990010	Diode - 6 Amp	6	
	3740069	Relay	2	
	1060341	Cable, Electrical - 16/2 (To Speed Cutout Switch/ To Lift Overload Switch)	23 ft./7m	
	1282024*	<b>STANDARD ELECTRICAL DIAGRAM (TOGGLE SWITCH DRIVE/MOLDED CONSOLE BOX - AUSTRALIAN SPEC) (DWG ONLY)</b>	Ref.	C
	4932610	Ground Components (B/M Only)	Ref.	B
	4932536	Platform Components (B/M Only)	Ref.	B
	4921615	Valve and Ground Control Harness	1	
	4460277	Strip, Terminal - 14 Position	1	
	4460264	Strip, Terminal	1	
	3990010	Diode - 6 Amp	10	
	3740069	Relay	1	
	1060341	Cable, Electrical - 16/2 (To Speed Cutout Switch/To Overload Switch)	24 ft./8m	

# SECTION 13-7 ELECTRICAL

## CM1432/CM1432 PLUS/CM1732



SECTION 13 - 7 ELECTRICAL

FIGURE & ITEM NO	PART NUMBER	DESCRIPTION	QTY.	REV.
13—7—1		<b>ELECTRICAL DIAGRAMS AND COMPONENTS CHART (CONTINUED)</b>	Ref.	
	1281885*	<b>STANDARD ELECTRICAL DIAGRAM (TOGGLE SWITCH DRIVE/MOLDED CONSOLE BOX - FRENCH SPEC) (DWG ONLY)</b>	Ref.	D
	4932537	<b>Ground Components (B/M Only)</b>	Ref.	A
	4932536	<b>Platform Components (B/M Only)</b>	Ref.	B
	4921467	Valve and Ground Control Harness	1	
	4460277	Strip, Terminal - 14 Position	1	
	4460264	Strip, Terminal	1	
	1060341	Cable, Electrical - 16/2 (To Speed Cutout)	30 ft./9m	
	1281560	<b>STANDARD ELECTRICAL DIAGRAM (PQ BANG-BANG DRIVE/STEEL CONSOLE BOX)</b>	Ref.	D
	4932425	<b>Ground Components (B/M Only)</b>	Ref.	—
	4932373	<b>Platform Components (B/M Only)</b>	Ref.	—
	4921385	Valve and Ground Control Harness	1	A
	4460277	Strip, Terminal - 14 Position	1	
	4460264	Strip, Terminal	1	
	4460007	Strip, Terminal - 6 Position	1	
	3990010	Diode - 6 Amp	6	
	1060341	Cable, Electrical - 16/2 (To Speed and Drive Cutout Switches/To Lift Limit Switch)	16 ft./4.9m	
	4921308	Harness, PQ Controller	1	
	3990010	Diode - 6 Amp	2	
	1281883*	<b>STANDARD ELECTRICAL DIAGRAM (PQ BANG-BANG DRIVE/MOLDED CONSOLE BOX - STANDARD EURO SPEC) (DWG ONLY)</b>	Ref.	D
	4932531	<b>Ground Components (B/M Only)</b>	Ref.	A
	4932530	<b>Platform Components (B/M Only)</b>	Ref.	—
	4921463	Valve and Ground Control Harness	1	
	4460277	Strip, Terminal - 14 Position	1	
	4460264	Strip, Terminal	1	
	4460007	Strip, Terminal - 6 Position	1	
	3990010	Diode - 6 Amp	6	
	3740069	Relay - 24VDC	2	
	1060341	Cable, Electrical - 16/2 (To Speed Cutout Switch/To Lift Limit Switch)	15 ft./4.6m	
	1282186*	<b>STANDARD ELECTRICAL DIAGRAM (PQ BANG-BANG DRIVE/MOLDED CONSOLE BOX - AUSTRALIAN SPEC) (DWG ONLY)</b>	Ref.	C
	4932688	<b>Ground Components (B/M Only)</b>	Ref.	A
	4932530	<b>Platform Components (B/M Only)</b>	Ref.	—
	4921660	Valve and Ground Control Harness	1	
	4460277	Strip, Terminal - 14 Position	1	
	4460264	Strip, Terminal	1	
	4460007	Strip, Terminal - 6 Position	1	
	3990010	Diode - 6 Amp	12	
	3740069	Relay - 24VDC	3	
	1060341	Cable, Electrical - 16/2 (To Cutout Switches/to Limit Switches)	30 ft./9m	

# SECTION 13-7 ELECTRICAL CM1432/CM1432 PLUS/CM1732



SECTION 13-7 ELECTRICAL

FIGURE & ITEM NO	PART NUMBER	DESCRIPTION	QTY.	REV.
13—7—1		<b>ELECTRICAL DIAGRAMS AND COMPONENTS CHART (CONTINUED)</b>	Ref.	
	1281886*	<b>STANDARD ELECTRICAL DIAGRAM (PQ BANG-BANG DRIVE/MOLDED CONSOLE BOX - FRENCH SPEC) (DWG ONLY)</b>	Ref.	E
	4932540	<b>Ground Components (B/M Only)</b>	Ref.	A
	4932539	<b>Platform Components (B/M Only)</b>	Ref.	—
	4921469	Valve and Ground Control Harness	1	
	4460277	Strip, Terminal - 14 Position	1	
	4460264	Strip, Terminal	2	
	4460007	Strip, Terminal - 6 Position	2	
	3990010	Diode - 6 Amp	9	
	3740069	Relay - 24VDC	5	
	1060341	Cable, Electrical - 16/2 (To Cutout Switches/to Limit Switches)	30 ft./7m	
	1281884	<b>STANDARD ELECTRICAL DIAGRAM (PQ PROPORTIONAL DRIVE/MOLDED CONSOLE BOX) (DWG ONLY)</b>	Ref.	E
	4932534	<b>Ground Components (B/M Only)</b>	Ref.	B
	4932533	<b>Platform Components (B/M Only)</b>	Ref.	—
	4921465	Valve and Ground Control Harness	1	A
	4460277	Strip, Terminal - 14 Position	1	
	4460264	Strip, Terminal	1	
	4460007	Strip, Terminal - 6 Position	1	
	3990010	Diode - 6 Amp	4	
	3740069	Relay - 24VDC	2	
	1060341	Cable, Electrical - 16/2 (To Speed Cutout Switch/To Lift Limit Switch)	23 ft./7m	
	3990010	Diode - 6 Amp	1	
	1282331	<b>STANDARD ELECTRICAL DIAGRAM (PQ PROPORTIONAL DRIVE/MOLDED CONSOLE BOX - STANDARD EURO SPEC) (DWG ONLY)</b>	Ref.	A
	4932738	<b>Ground Components (B/M Only)</b>	Ref.	—
	4932533	<b>Platform Components (B/M Only)</b>	Ref.	—
	4921706	Valve and Ground Control Harness	1	—
	4460277	Strip, Terminal - 14 Position	1	
	4460264	Strip, Terminal	1	
	4460007	Strip, Terminal - 6 Position	1	
	3990010	Diode - 6 Amp	8	
	3740069	Relay - 24VDC	3	
	1060341	Cable, Electrical - 16/2 (To Speed Cutout Switch/To Lift Limit Switch)	23 ft./7m	
	3990010	Diode - 6 Amp	1	

# SECTION 13-7 ELECTRICAL CM1432/CM1432 PLUS/CM1732



FIGURE & ITEM NO	PART NUMBER	DESCRIPTION	QTY.	REV.
13—7—1		<b>ELECTRICAL DIAGRAMS AND COMPONENTS CHART (CONTINUED)</b>	Ref.	
	1281887	<b>STANDRD ELECTRICAL DIAGRAM (PQ PROPORTIONAL DRIVE/MOLDED CONSOLE BOX - FRENCH SPEC) (DWG ONLY)</b>	Ref.	E
	4932543	<b>Ground Components (B/M Only)</b>	Ref.	B
	4932542	<b>Platform Components (B/M Only)</b>	Ref.	—
	4921471	Valve and Ground Control Harness	1	A
	4460277	Strip, Terminal - 14 Position	1	
	4460264	Strip, Terminal	2	
	4460007	Strip, Terminal - 6 Position	2	
	3990010	Diode - 6 Amp	7	
	3740069	Relay - 24VDC	5	
	1060341	Cable, Electrical - 16/2 (To Cutout Switches/To Limit Switches)	23 ft./7m	
	3990010	Diode - 6 Amp	1	

SECTION 13 - 7 ELECTRICAL



# SECTION 13-7 ELECTRICAL CM1432/CM1432 PLUS/CM1732

FIGURE 13-7-3. ELECTRICAL DIAGRAM - TOGGLE  
SWITCH DRIVE (AUSTRALIA SPEC).

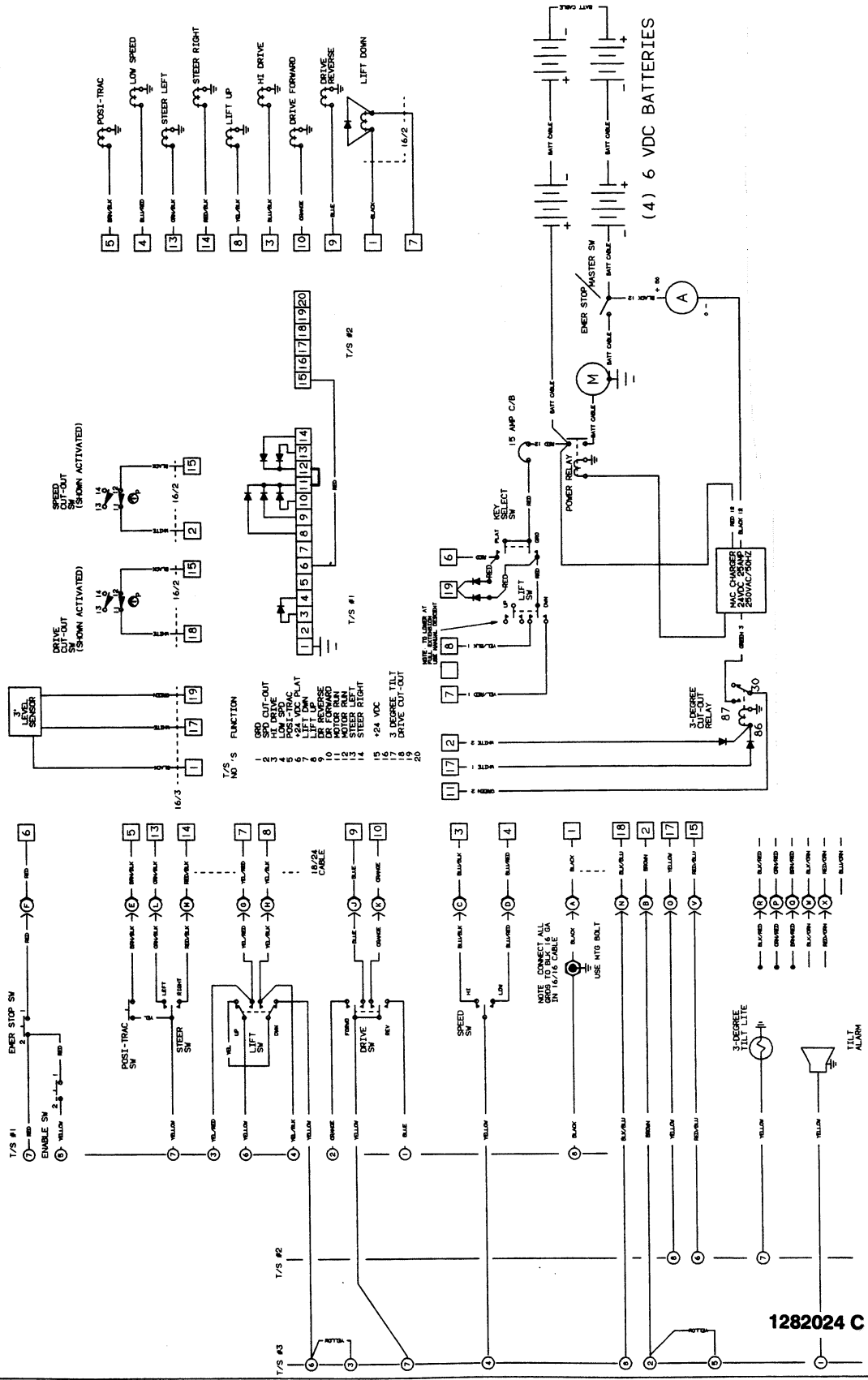
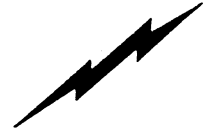

1282024 C

13-7 ELECTRICAL NOTATIONS





# SECTION 13-7 ELECTRICAL CM1432/CM1432 PLUS/CM1732

FIGURE 13-7-5. ELECTRICAL DIAGRAM - PQ CONTROLLER  
BANG-BANG DRIVE (STANDARD EURO SPEC).

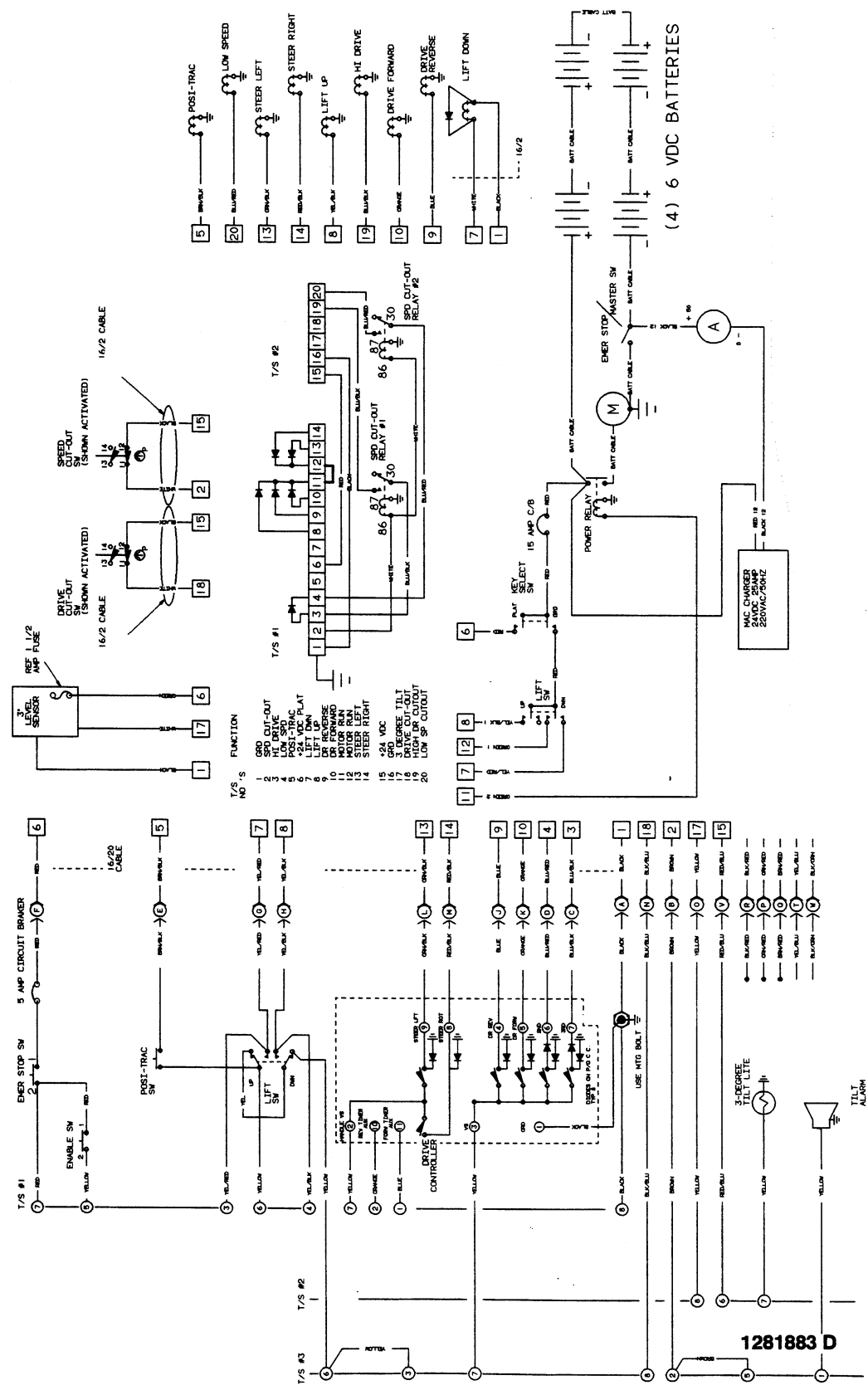
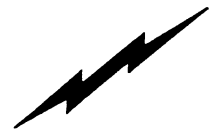

SECTION 13-7 ELECTRICAL



# SECTION 13-7 ELECTRICAL CM1432/CM1432 PLUS/CM1732

FIGURE 13-7-7. ELECTRICAL DIAGRAM - PQ CONTROLLER  
BANG-BANG DRIVE (FRENCH SPEC).

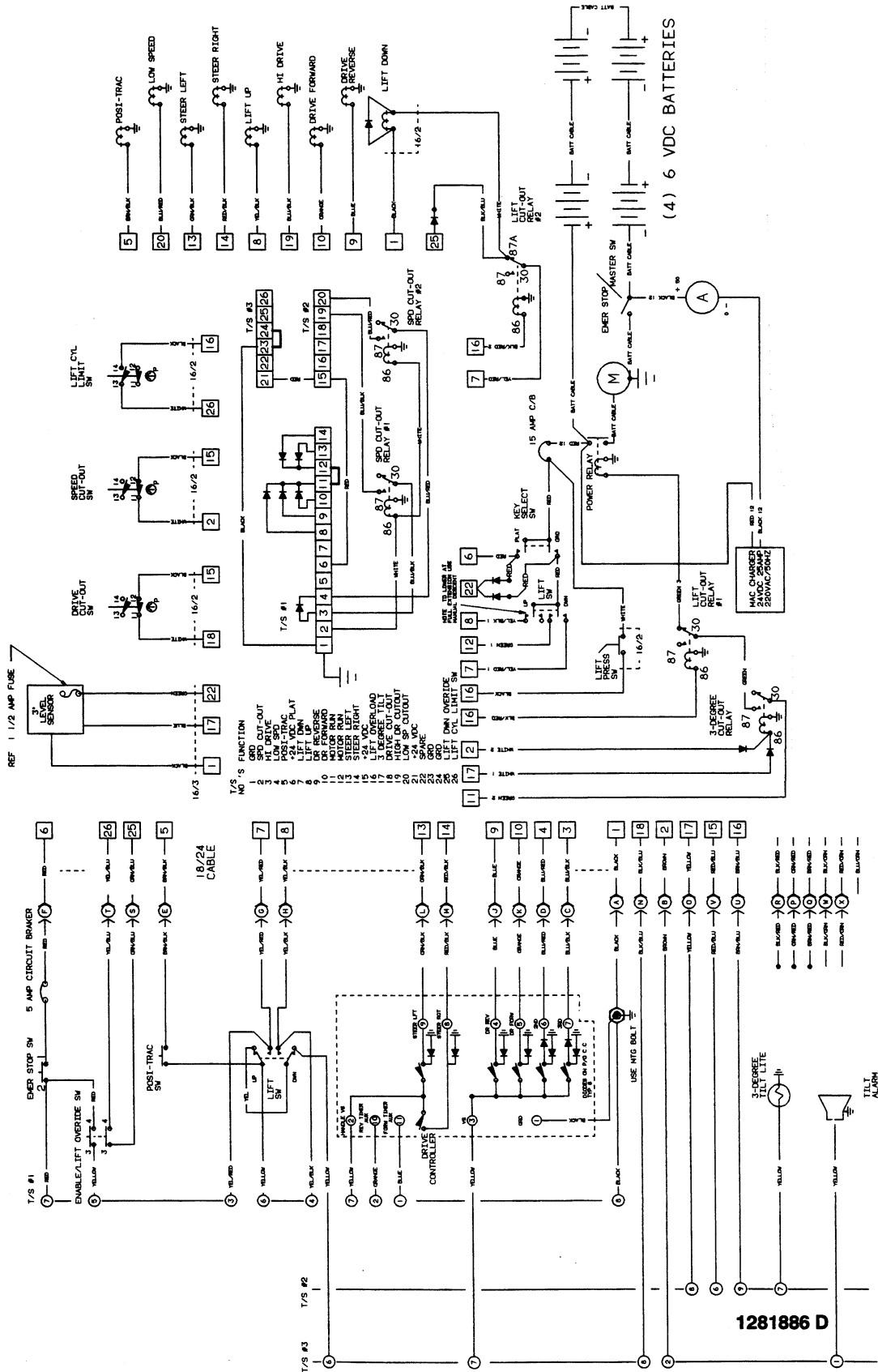

CALCULATED 7-13-NO-TOMS



# SECTION 13-7 ELECTRICAL CM1432/CM1432 PLUS/CM1732

FIGURE 13-7-8. ELECTRICAL DIAGRAM - CIRCUIT CARDS.

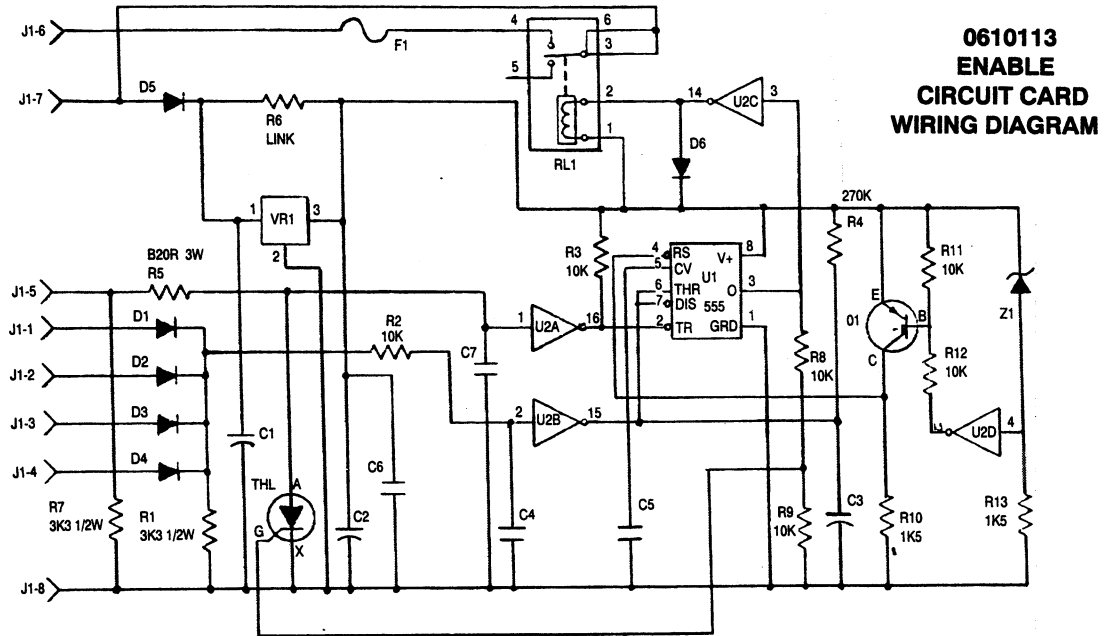

0610105  
RELAY  
CIRCUIT CARD  
WIRING DIAGRAM

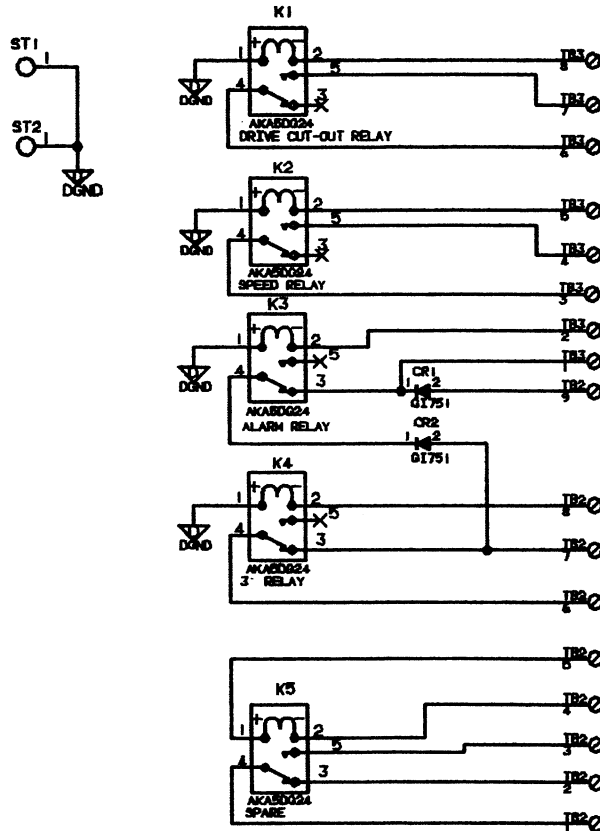

SECTION 13 - 7 ELECTRICAL

# SECTION 13-7 ELECTRICAL CM1432/CM1432 PLUS/CM1732

FIGURE 13-7-9. MAIN ELECTRICAL CONNECTOR AND TOOLS.

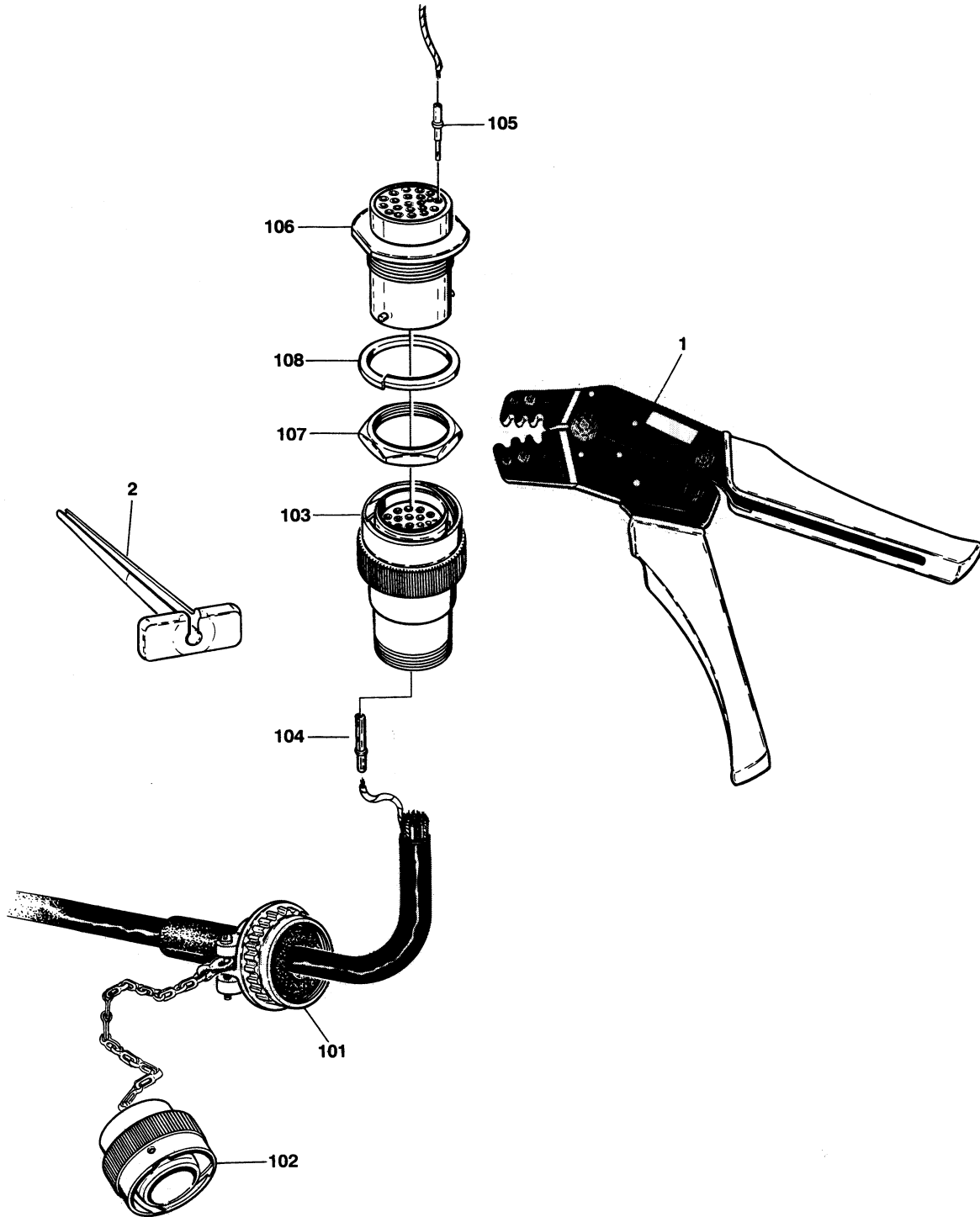

SECTION  
13 - 7  
ELECTRICAL

# SECTION 13-7 ELECTRICAL CM1432/CM1432 PLUS/CM1732



FIGURE & ITEM NO	PART NUMBER	DESCRIPTION	QTY.	REV.
13-7-9		<b>MAIN ELECTRICAL CONNECTOR AND TOOLS</b>	Ref.	
		<b>Tools:</b>	Ref.	
—1	7002818	Crimper (For Wire to Pin/Socket Connections)	1	
—2	4460467	Extractor (For Removal of Pins/Sockets from Connectors)	1	
		<b>Connector Components:</b>	Ref.	
—101	4460473	Clamp, Cable	1	
—102	4460468	Cap, Dust	1	
—103	4460462	Plug, Connector - 23 Pin (Female)	1	
—104	4460465	Socket, Female	A/R	
—105	4460464	Pin, Male	A/R	
—106	4460463	Receptacle, Connector - 23 Pin (Male)	1	
—107	4460470	Nut, Receptacle	1	
—108	4460471	Lockwasher, Receptacle	1	

SECTION 13 - 7 ELECTRICAL





**SECTION 13-8 DECALS  
CM1432/CM1432 PLUS/CM1732**



**TABLE OF CONTENTS**

FIGURE NO.	TITLE	PAGE NO.
13-8-1	Decals Installation - CM1432/CM1432 Plus .....	13-8-2
13-8-2	Decals Installation - CM1732 .....	13-8-6

**S  
E  
C  
T  
I  
O  
N  
  
1  
3  
-  
8  
  
D  
E  
C  
A  
L  
S**

# SECTION 13-8 DECALS CM1432/CM1432 PLUS/CM1732



FIGURE 13-8-1. DECALS INSTALLATION - CM1432/CM1432 PLUS.

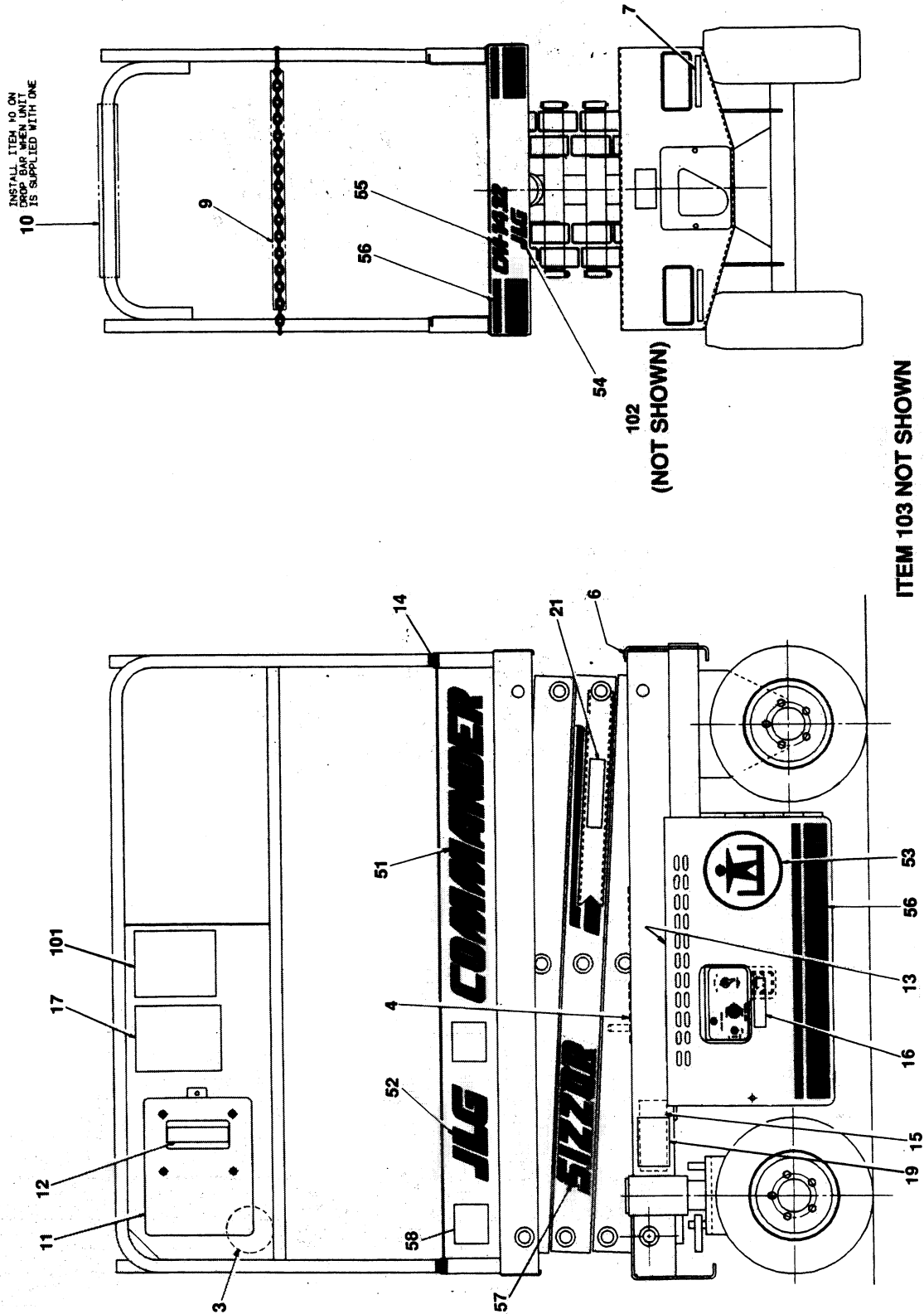

# SECTION 13-8 DECALS

## CM1432/CM1432 PLUS/CM1732



FIGURE & ITEM NO	PART NUMBER	DESCRIPTION	QTY.	REV.
13—8—1	1281641	<b>DECALS INSTALLATION - COMMON CM1432 AND CM1432 PLUS (STANDARD PARTS)</b>	Ref.	R
—1	Not Used			
—2	Not Used			
—3	3251813*◆	Decal - USA (Opposite Side)	1	
—4	1701504*◆	Decal - Hydraulic Fluid (Opposite Side)	1	
—5	Not Used			
—6	4420039	Tape, Safety Tread	2 ft./6m	
—7	1701508*◆	Decal - Fork Lift Area	2	
—8	Not Used			
—9	Not Used			
—10	3340612	Padding	2 ft./6m	
—11	0860520	Box, Manual Storage	1	
	0641405	Bolt 1/4"-20NC x 5/8"	4	
	4751400	Flatwasher 1/4"	4	
	4761400	Lockwasher 1/4"	4	
	3311401	Nut 1/4"-20NC	4	
	1060279	Cable, Lanyard (Not Shown)	1	
—12	1701509*◆	Decal, manual	1	
—13	3960389	Seal, Rubber	5 ft./1.5m	
—14	0840035	Boot, Handrail	4	
	0252093	<b>DECALS INSTALLATION - EURO ENGLISH (VARIABLE PARTS)</b>	Ref.	C
—15	Consult Factory	Nameplate - Serial Number (Opposite Side)	1	
	3820014	Rivet	4	
—16	1701122	Decal - Ground Control	1	
—17	1701523	Nameplate - Caution	1	
—18	3252131	Nameplate - Danger	1	
—19	1701510*◆	Decal - Manual Lowering	1	
—20	Not Used			
—21	1700713	Decal - Safety prop	1	
	0252833	<b>DECALS INSTALLATION - FRENCH (VARIABLE PARTS)</b>	Ref.	A
—15	Consult Factory	Nameplate - Serial Number (Opposite Side)	1	
	3820014	Rivet	4	
—16	1701515	Decal - Commandes Sol	1	
—17	1701629	Decal - Attention	1	
—18	3252131	Nameplate - Danger	1	
—19	1701510*◆	Decal - Manual Lowering	1	
—20	Not Used			
—21	1701512	Decal - Support De Sécurité	1	

SECTION 13 - 8 DECALS

**SECTION 13-8 DECALS**  
**CM1432/CM1432 PLUS/CM1732**



**SECTION 13 - 8 DECALS**

FIGURE & ITEM NO	PART NUMBER	DESCRIPTION	QTY.	REV.
13-8-1		<b>DECALS INSTALLATION - CM1432 AND CM1432 PLUS (CONTINUED)</b>	Ref.	
	0252834	<b>DECALS INSTALLATION - GERMAN (VARIABLE PARTS)</b>	Ref.	A
-15	Consult Factory	Nameplate - Serial Number (Opposite Side)	1	
	3820014	Rivet	4	
-16	1701525	Decal - Boden/Notfall Kontrolle	1	
-17	1701630	Decal - Achtung	1	
-18	3252131	Nameplate - Danger	1	
-19	1701510*◆	Decal - Manual Lowering	1	
-20	Not Used			
-21	1701519	Decal - Sicherheitsstütze	1	
	0252836	<b>DECALS INSTALLATION - DUTCH (VARIABLE PARTS)</b>	Ref.	A
-15	Consult Factory	Nameplate - Serial Number (Opposite Side)	1	
	3820014	Rivet	4	
-16	1701616	Decal - Grondbediening	1	
-17	1701648	Decal - Dagelijkse Controlelijst	1	
-18	3252131	Nameplate - Danger	1	
-19	1701510*◆	Decal - Manual Lowering	1	
-20	Not Used			
-21	1701615	Decal - Veiligheidsbalk	1	
	0252835	<b>DECALS INSTALLATION - ITALIAN (VARIABLE PARTS)</b>	Ref.	A
-15	Consult Factory	Nameplate - Serial Number (Opposite Side)	1	
	3820014	Rivet	4	
-16	1701535	Decal - Commando A Terra	1	
-17	1701632	Decal - Attenzione	1	
-18	3252131	Nameplate - Danger	1	
-19	1701510*◆	Decal - Manual Lowering	1	
-20	Not Used			
-21	1701524	Decal - Appoggio Di Sicurezza	1	
	0253624	<b>DECALS INSTALLATION - SPANISH (VARIABLE PARTS)</b>	Ref.	A
-15	Consult Factory	Nameplate - Serial Number (Opposite Side)	1	
	3820014	Rivet	4	
-16	1701858	Decal - Controles Tierra/Emerg	1	
-17	1701861	Decal - Precaucion	1	
-18	3252131	Nameplate - Danger	1	
-19	1701510*◆	Decal - Manual Lowering	1	
-20	Not Used			
-21	1701856	Decal - Puntal De Seguridad	1	

**SECTION 13-8 DECALS**  
**CM1432/CM1432 PLUS/CM1732**



FIGURE & ITEM NO	PART NUMBER	DESCRIPTION	QTY.	REV.
13-8-1		<b>DECALS INSTALLATION - CM1432 AND CM1432 PLUS (CONTINUED)</b>	Ref.	
	0252091	<b>DECALS INSTALLATION - COMMON (BROWN) (VARIABLE PARTS)</b>	Ref.	A
-51	1701069*	Decal - Commander	2	
-52	1701110*	Decal - JLG	3	
-53	1701408*	Decal - Logo	1	
-54	1701409*	Decal - JLG	1	
-55	1701552*	Decal - CM1432	2	
-56	1700431*	Decal - Brown/Orange Stripe	8.3 ft./2.5m	
-57 to -58	Not Required			
	2900845*	Decal Kit - Brown (Includes Items with *)	1	
	0252867	<b>DECALS INSTALLATION - COMMON (BLACK) (VARIABLE PARTS)</b>	Ref.	F
-51	1701613◆	Decal - Commander (Prior to April 1993)	2	
	1702011◆	Decal - Commander (April 1993 to Present)	2	
-52	1701435◆	Decal - JLG (Prior to April 1993)	3	
	1702009◆	Decal - JLG (April 1993 to Present)	3	
-53	Not Required			
-54	1701612	Decal - JLG (Prior to April 1993)	1	
	1702010◆	Decal - JLG (April 1993 to Present)	2	
-55	1701727	Decal - CM1432 (Prior to April 1993)	2	
	1792017◆	Decal - CM1432 (April 1993 to Present)	2	
-56	1701334	Decal - Black Stripe (Prior to April 1993)	8.3 ft./2.5m	
	1702015◆	Decal - Black Stripe (April 1993 to Present)	12 ft./3.7m	
-57	1702029	Decal - Sizzor (April 1993 to Present)	2	
-58	3252631	Decal - Bar Code	1	
	2900846◆	Decal Kit - Black (Includes Items with ◆)	1	
	0010439	<b>DECALS INSTALLATION - EURO OPTIONAL (VARIABLE PARTS)</b>	Ref.	B
-101		<b>Capacity Decal Options:</b>	2	
	3252131	Decal - 230KG (CM1432)		
	3252299	Decal - 270KG (CM1432 Plus)		
-102	1702028	Decal - Plus (CM1432 Plus Only)	2	
-103	1701500	Decal - Lifting Lug (Optional)	4	
	0251642	<b>CORNER WARNING STRIPES INSTALLATION (EXTENDABLE PLATFORM ONLY) (NOT SHOWN)</b>	Ref.	—
	4420052	Tape, Safety (Black/Yellow)	4 ft./1.2m	
	0255981	<b>CE DECAL INSTALLATION (NOT SHOWN)</b>	Ref.	—
	3252482	Decal - CE	2	

**SECTION 13-8 - DECALS**

# SECTION 13-8 DECALS CM1432/CM1432 PLUS/CM1732



FIGURE 13-8-2. DECALS INSTALLATION - CM1732.

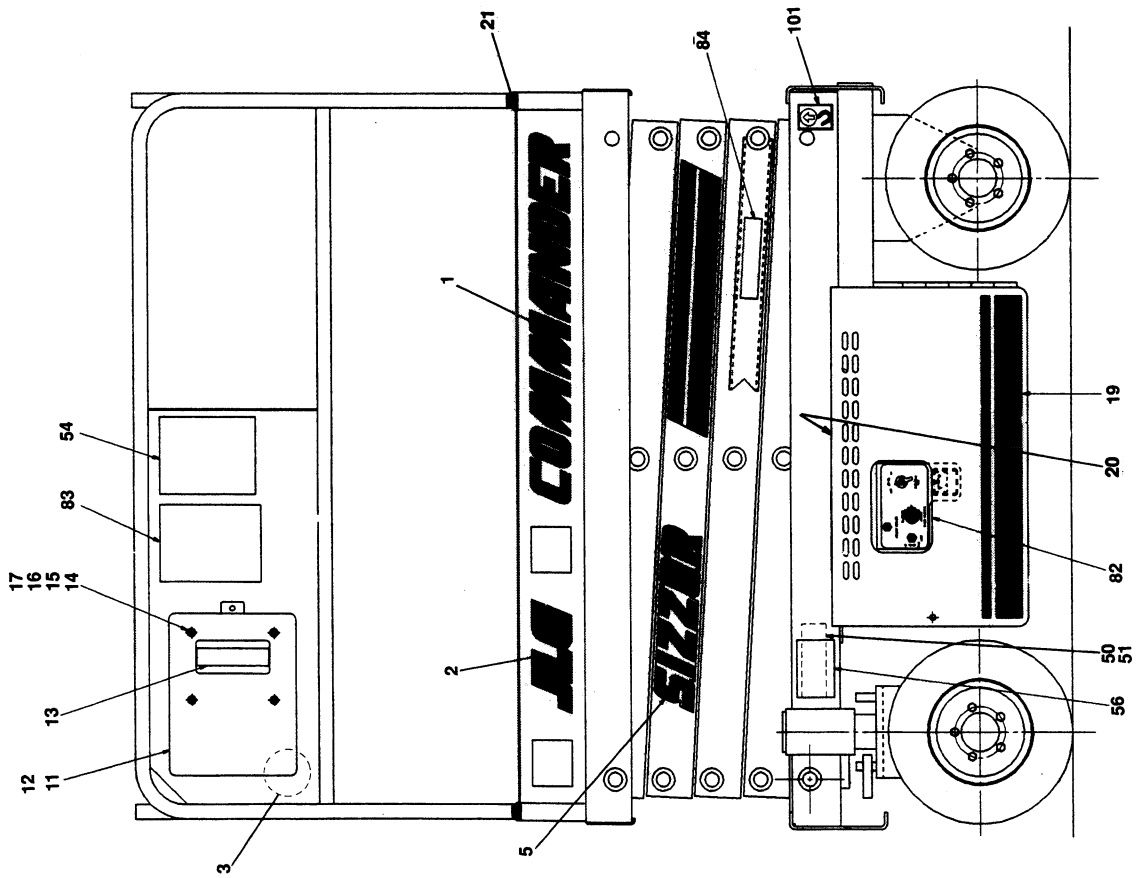
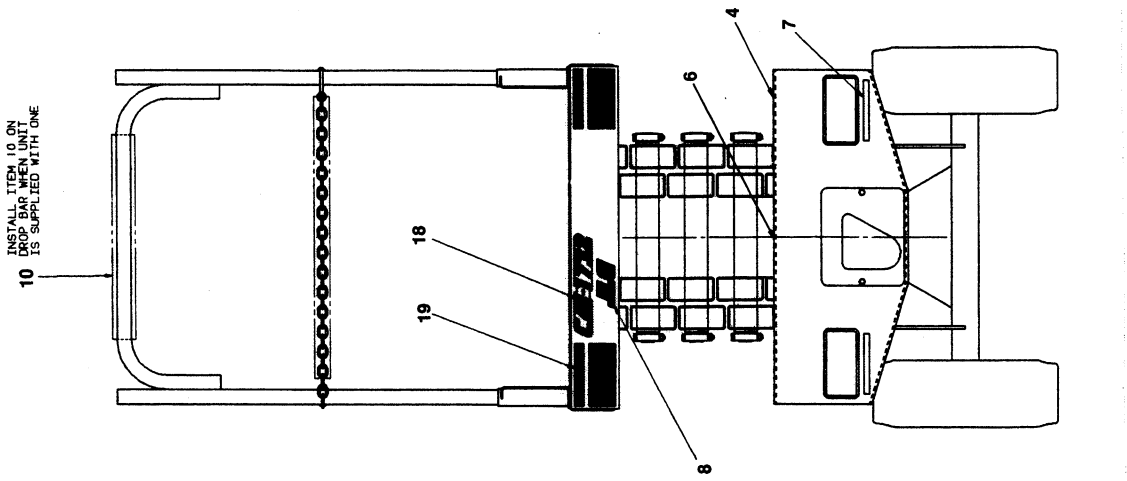

# SECTION 13-8 DECALS CM1432/CM1432 PLUS/CM1732



FIGURE & ITEM NO	PART NUMBER	DESCRIPTION	QTY.	REV.
13-8-2		<b>DECALS INSTALLATION - CM1732</b>	Ref.	
	0254008	<b>DECALS INSTALLATION - COMMON PARTS</b>	Ref.	D
-1	1702011*	Decal - Commander	2	
-2	1702009*	Decal - JLG	3	
-3	3251813*	Decal - USA	1	
-4	1701504*	Decal - Hydraulic Fluid	1	
-5	1702029*	Decal - Sizzor	2	
-6	4420039*	Tape - Safety Tread	2 ft./6m	
-7	1701508*	Decal -Forklift Area	2	
-8	1702010*	Decal - JLG	2	
-9	Not Used			
-10	3340612	Pad	2 ft./6m	
-11	0860520	Box, Manual Storage	1	
-12	1060279	Cable, Lanyard	1	
-13	1701509*	Decal - Manual	1	
-14	0641405	Bolt 1/4"-20NC x 5/8"	4	
-15	4751400	Flatwasher 1/4"	4	
-16	4761400	Lockwasher 1/4"	4	
-17	3311401	Nut 1/4"-20NC	4	
-18	1702013*	Decal - CM1732	2	
-19	1702015*	Decal - Stripe (Black)	12 ft./3.7m	
-20	3960389	Seal, Rubber	5 ft./1.5m	
-21	0840035	Boot, Handrail	4	
	1282089	<b>DECALS INSTALLATION - EURO (STANDARD)</b>	Ref.	G
-50	Consult Factory	Nameplate - Serial Number	1	
-51	3820014	Rivet 1/8" x 5/16"	4	
-52	Not Used			
-53	Not Used			
-54	3252131*	Nameplate - Capacity	1	
-55	Not Used			
-56	1701510*	Decal - Manual Lowering	1	
	2900847*	Decal Kit - 1732 (Includes Items with *)	1	
	0254010	<b>DECALS INSTALLATION - EURO ENGLISH (VARIABLE PARTS)</b>	Ref.	—
-81	Not Used			
-82	1701122	Decal - Ground Control	1	
-83	1701523	Nameplate - Caution	1	
-84	1700713	Decal - Safety Prop	1	
	0254011	<b>DECALS INSTALLATION - FRENCH (VARIABLE PARTS)</b>	Ref.	—
-81	Not Used			
-82	1701515	Decal - Commandes Sol	1	
-83	1701629	Decal - Attention	1	
-84	1701512	Decal - Support De Sécurité	1	

SECTION 13 - 8 DECALS

**SECTION 13-8 DECALS**  
**CM1432/CM1432 PLUS/CM1732**



**SECTION 13-8 DECALS**

FIGURE & ITEM NO	PART NUMBER	DESCRIPTION	QTY.	REV.
13-8-2		<b>DECALS INSTALLATION - CM1732 (CONTINUED)</b>	Ref.	
	0254012	<b>DECALS INSTALLATION - GERMAN (VARIABLE PARTS)</b>	Ref.	—
—81	Not Used			
—82	1701525	Decal - Boden/Notfall Kontrolle	1	
—83	1701630	Decal - Achtung	1	
—84	1701519	Decal - Sicherheitsst	1	
	0254013	<b>DECALS INSTALLATION - ITALIAN (VARIABLE PARTS)</b>	Ref.	—
—81	Not Used			
—82	1701535	Decal - Commando A Terra	1	
—83	1701632	Decal - Attenzione	1	
—84	1701524	Decal - appoggio Di Sicurezza	1	
	0254014	<b>DECALS INSTALLATION - DUTCH (VARIABLE PARTS)</b>	Ref.	—
—81	Not Used			
—82	1701616	Decal - Grondbediening	1	
—83	1701648	Decal - Dagelijkse Controlelijst	1	
—84	1701615	Decal - Beiligheidsbalk	1	
	0254016	<b>DECALS INSTALLATION - SPANISH (VARIABLE PARTS)</b>	Ref.	—
—81	Not Used			
—82	1701858	Decal - Controles Tierra/Emerg	1	
—83	1701861	Decal - Precaucion	1	
—84	1701856	Decal - Puntal De Seguridad	1	
	0010484	<b>DECALS INSTALLATION - OPTIONAL</b>	Ref.	—
—101	1701500	Decal - Lifting Lug	4	
	0251642	<b>CORNER WARNING STRIPES INSTALLATION (EXTENDABLE PLATFORM ONLY) (NOT SHOWN)</b>	Ref.	—
	4420052	Tape, Safety (Black/Yellow)	4 ft./1.2m	
	0255981	<b>CE DECAL INSTALLATION (NOT SHOWN)</b>	Ref.	—
	3252482	Decal - CE	2	





# TRANSFER OF OWNERSHIP

To: JLG, Gradall, Lull and Sky Trak product owner:

If you now own, but ARE NOT the original purchaser of the product covered by this manual, we would like to know who you are. For the purpose of receiving safety-related bulletins, it is very important to keep JLG Industries, Inc. updated with the current ownership of all JLG products. JLG maintains owner information for each JLG product and uses this information in cases where owner notification is necessary.

Please use this form to provide JLG with updated information with regard to the current ownership of JLG Products. Please return completed form to the JLG Product Safety & Reliability Department via facsimile (717) 485-6573 or mail to address as specified on the back of this form.

Thank you,  
Product Safety & Reliability Department  
JLG Industries, Inc.  
1 JLG Drive  
McConnellsburg, PA 17233-9533  
Telephone: (717) 485-5161  
Fax: (717) 485-6573

NOTE: Leased or rented units should not be included on this form.

Mfg. Model: \_\_\_\_\_

Serial Number: \_\_\_\_\_

Previous Owner: \_\_\_\_\_

Address: \_\_\_\_\_

City: \_\_\_\_\_ State: \_\_\_\_\_

Zip: \_\_\_\_\_ Telephone: ( \_\_\_\_\_ ) \_\_\_\_\_

Date Of Transfer: \_\_\_\_\_

Current Owner: \_\_\_\_\_

Address: \_\_\_\_\_

City: \_\_\_\_\_ State: \_\_\_\_\_

Zip: \_\_\_\_\_ Telephone: ( \_\_\_\_\_ ) \_\_\_\_\_

Who in your organization should we notify?

Name: \_\_\_\_\_

Title: \_\_\_\_\_

Please cut on the dotted line and fax to 717-485-6573









Corporate Office  
JLG Industries, Inc.  
1 JLG Drive  
McConnellsburg PA. 17233-9533  
USA  
Phone: (717) 485-5161  
Fax: (717) 485-6417

## JLG Worldwide Locations

---

JLG Industries (Australia)  
P.O. Box 5119  
11 Bolwarra Road  
Port Macquarie  
N.S.W. 2444  
Australia  
Phone: (61) 2 65 811111  
Fax: (61) 2 65 810122

JLG Industries (UK)  
Unit 12, Southside  
Bredbury Park Industrial Estate  
Bredbury  
Stockport  
SK6 2sP  
England  
Phone: (44) 870 200 7700  
Fax: (44) 870 200 7711

JLG Deutschland GmbH  
Max Planck Strasse 21  
D-27721 Ritterhude/Ihlpohl  
Bei Bremen  
Germany  
Phone: (49) 421 693 500  
Fax: (49) 421 693 5035

JLG Industries (Italia)  
Via Po. 22  
20010 Pregnana Milanese - MI  
Italy  
Phone: (39) 02 9359 5210  
Fax: (39) 02 9359 5845

JLG Latino Americana Ltda.  
Rua Eng. Carlos Stevenson,  
80-Suite 71  
13092-310 Campinas-SP  
Brazil  
Phone: (55) 19 3295 0407  
Fax: (55) 19 3295 1025

JLG Europe B.V.  
Jupiterstraat 234  
2132 HJ Foofddorp  
The Netherlands  
Phone: (31) 23 565 5665  
Fax: (31) 23 557 2493

JLG Industries (Norge AS)  
Sofeimyrveien 12  
N-1412 Sofienyr  
Norway  
Phone: (47) 6682 2000  
Fax: (47) 6682 2001

JLG Polska  
Ul. Krolewska  
00-060 Warszawa  
Poland  
Phone: (48) 91 4320 245  
Fax: (48) 91 4358 200

JLG Industries (Europe)  
Kilmartin Place,  
Tannochside Park  
Uddingston G71 5PH  
Scotland  
Phone: (44) 1 698 811005  
Fax: (44) 1 698 811055

JLG Industries (Pty) Ltd.  
Unit 1, 24 Industrial Complex  
Herman Street  
Meadowdale  
Germiston  
South Africa  
Phone: (27) 11 453 1334  
Fax: (27) 11 453 1342

Plataformas Elevadoras  
JLG Iberica, S.L.  
Trapadella, 2  
P.I. Castellbisbal Sur  
08755Castellbisbal  
Spain  
Phone: (34) 93 77 24700  
Fax: (34) 93 77 11762

JLG Industries (Sweden)  
Enkopingsvagen 150  
Box 704  
SE - 175 27 Jarfalla  
Sweden  
Phone: (46) 8 506 59500  
Fax: (46) 8 506 59534

---